

AMERICAN

Copy to 7

U.S. NAVAL TECHNICAL MISSION IN EUROPE

AD-A953 447

RECORDS
2531
ATTN. NO. 133827
CADD FILE COPY

~~CONFIDENTIAL~~
UNCLASSIFIED

TECHNICAL REPORT NO. 417-45

GERMAN AAL
AND
AA 106 MINE UNITS

BEST AVAILABLE COPY

September 1945

~~CONFIDENTIAL~~
UNCLASSIFIED
DECLASSIFIED
DOD DIR 5200.9

DTIC
ELECTE
AUG 3 1984
S D

UNCL FILE COPY

U.S. NAVAL TECHNICAL MISSION IN EUROPE

DISTRIBUTION STATEMENT A
Approved for public release;
Distribution Unlimited

84 05 15,532

AG 440, P-9

U. S. NAVAL TECHNICAL MISSION IN EUROPE
c/o Fleet Post Office
New York, N.Y.

File: A9-16(3)(40/Hn)

Serial: 01153

25 September 1945.

UNCLASSIFIED

From: Chief, U.S. Naval Technical Mission in Europe.
To : Chief of Naval Operations (OP-16-PT).

Subject: U.S. Naval Technical Mission in Europe Technical
Report No. 417-45, German AA4 and AA 106 Mine
Units - Forwarding of.

Enclosures: (A) (HW) Four (4) complete copies of subject report
as listed in distribution.
(B) (HW) One (1) set of negatives of photographs in
subject report with copy No. 17 as listed
in distribution.

1. Enclosures (A) and (B) are forwarded herewith.
2. CNO (OP-16-PT) is requested to make complete additional copies of this report for forwarding to such other agencies as may be interested.

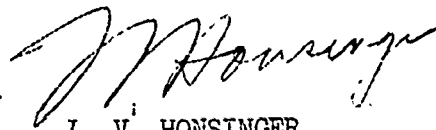
L. V. HONSINGER
Capt. U. S. N.
Acting

DISTRIBUTION TO:

CNO (OP-16-PT)	Copy Nos. 1 - 4
FIAT	Copy No. 5
Office of Research and Invention	Copy No. 6
ComNavEu	Copy No. 7
ComNavEu for Admiralty	Copy No. 8
BuShips (Code 620)	Copy No. 9
BuOrd (Rc)	Copy No. 10
BuOrd (Rc 6)	Copy No. 11
BuOrd (Rc7a)	Copy No. 12
CNO (OP-30-31)	Copy No. 13
Mine Disposal School	Copy No. 14
NOL	Copy No. 15
NavTechMisEu (Mission files)	Copy No. 16
CNO (OP-16-PT)	w/Enclosure B Copy No. 17

Accession For	
NTIS GRA&I	<input checked="" type="checkbox"/>
DTIC TAB	<input checked="" type="checkbox"/>
Unannounced	<input type="checkbox"/>
Justification	<input type="checkbox"/>
By Rex Ltv	
Distribution/	
Availability Codes	
Dist	Avail and/or Special
A/1	

DTIC
COPY
INSPECTED
1

Released



UNCLASSIFIED

TECHNICAL REPORT NO. 417-45

UNANNOUNCED

GERMAN AA 4 AND AA 106 MINE UNITS

SUMMARY

This report contains information on the German AA 4 and AA 106 mine firing units. These units are combined acoustic-supersonic operated devices. AA 4 was designed to be used in the EmF and SmA mines. The AA 106 was designed to be used in the Bm 1000 H and Bm 1000 L mines. Both reached development stage, but were not produced nor used operationally during the war.

September 1945

U. S. NAVAL TECHNICAL MISSION IN EUROPE

DTIC
ELECTE
S AUG 3 1984 **D**
D

DISTRIBUTION STATEMENT A
Approved for public release;
Distribution Unlimited

UNCLASSIFIED

TABLE OF CONTENTS

	<u>Page</u>
1. Introduction	3
2. General	3
3. AA 4	4
4. AA 4 Circuits	4
5. AA 106 Acoustic Triggering Circuit	5
6. AA 106 Supersonic Receivers	5
7. AA 106 Float and Float Release	5
8. AA 106 Arming	6
9. AA 106 Triggering	7
10. AA 106 Amplifier I	7
11. AA 106 Amplifier II	7
12. AA 106 Firing Circuit	7
13. AA 106 P.S.E. & Anti-Leak Device	8
14. AA 106 Remarks	8

LIST OF ILLUSTRATIONS

1. Schematic Drawing AA 4 Receivers and Amplifier System.	9
2. Characteristics of AA 106 Receivers	10
3. Mounting of AA 106 Float in BM 1000 H or BM 1000 L Mine.	11
4. AA 106 Receivers Reaction to Ship Transit at 11 kts.	12
5. AA 106 Receivers Reaction to Ship Transit at 20 kts.	13
6. AA 106 Receivers Reaction to Ship Passing 20 meters Abeam with Noise -Buoy.	14
7. AA 106 Circuit Diagram.	15

~~CONFIDENTIAL~~

GERMAN AA 4 AND AA 106 MINE UNITS

1. Introduction.

(a) Part of the German mine development program was directed to work on supersonic fired mines. At the end of the war in Europe four supersonic units were under development, and of these one (AA 4) had been abandoned. The units were designated AE 1, AA 4, AE 101 and AA 106. Of these, the AE 1 and AE 101 are active. ("pinging") supersonic units. The AA 4 and AA 106 are passive directional supersonic units. This report will be confined to the passive units. The active units are reported separately in NavTechMisEu Technical Report No. 290-45.

(b) Very little material has been captured, but considerable documentary information is available, and microfilm negatives of these documents have been forwarded to U.S. The information contained herein has been obtained through field examination of material, preliminary screening of documents, and interrogation of German prisoners of war.

2. General.

The German AA 4 and AA 106 are directional supersonic mine firing units. Due to the directional requirements, self-orienting properties are necessary to the directional elements. At first, SVK attempted to mount a group of directional magnetostrictive receivers (7 in number) in a belt around an LMB mine case. The top-most receiver was selected for operation by a weighted internal pendulum switch. This was unsuccessful. In the case of the AA 4, which was designed for use in the EMF and SMA mines, the directional elements were mounted in the cover-plate and, since the mine-case is self-orienting, no additional provision was necessary for vertical orientation. In the case of the AA 106 (sometime referred to as A 106), the unit is designed for use in the BM 1000 H and BM 1000 L ground mines. When used in ground mines the directional elements are mounted in a small float which is moored on a $\frac{1}{2}$ - 1 meter length cable from the mine. The float is released shortly after the mine reaches the bottom. The supersonic system is switched on, to save battery power, by a simple sonic acoustic system of low power consumption. The supersonic receivers were designed to fire when the target was nearly overhead and to discriminate against ships passing abeam.

CONFIDENTIAL

3. AA 4.

The AA 4 unit was started by SVK (navy) in 1943. It was abandoned in 1944 in favor of the Luftwaffe's AA 106 unit due to an agreement with the Luftwaffe concerning parallel developments. The AA 4 used nine (9) magnetostrictive receivers tuned to 25 kc. mounted on the cover plate of an EMF or SMA mine. Of the nine receivers, one was sharply-tuned vertically-directive receiver, and the other eight were broadly-tuned receivers with directional characteristic. The receivers were arranged as shown in Figure 1, with the eight broadly-tuned receivers arranged in a circle around the vertical receiver. The eight circumferential receivers were designed to operate in pairs and the coils of each pair (which were placed diametrically opposite) were wound in opposite directions. Thus, a sound from overhead would find the receivers of all four pairs in phase with each other with respect to that sound, and the resultant potentials produced would nullify each other, (Figure 1). However, when the sound did not originate from overhead, a differential potentials (uH), which was used in the circuit for comparison with the potential produced by the sharply-tuned vertical receiver would appear.

4. AA 4 Circuits.

Several circuits were experimented with for the AA 4 unit. The first one used separate three-stage vacuum-tube amplifiers for the vertical and horizontal directional systems. The output potentials were fed to a differentiating relay, and when the sound originated from over the mine it fired. Some difficulties were encountered with the use of two parallel amplifiers, since construction of two amplifiers with identical characteristics prove to be difficult. The second circuit used a common amplifier for the two systems, with a periodic switching as shown in Figure 1 to allow both systems alternate use of the amplifier. The third circuit used a common amplifier, but each system was connected to a modulator with a 10 kc. oscillator. Since the resonant frequency of the receivers was 25 kc., the resultant beat notes were 35 kc and 15 kc in each channel. The vertical channel was then filtered to pass 35 kc. only, and the horizontal channel filtered to pass 15 kc only. Thus, the two signals were fed to a common amplifier, amplified, re-filtered into two channels,

CONFIDENTIAL

4. AA 4 Circuits.

and finally to the differentiating relay. All three of these circuits are shown schematically in Figure 1.

5. AA 106 - Acoustic Triggering Circuit.

The acoustic triggering circuit is designed to switch on the supersonic circuit when ship noises are detected. It is very simple, and consists of a microphone, transformer, rectifier and relay. The frequencies used are in the 200 - 500 cps range. The acoustic triggering system is so arranged in the circuit that continuous acoustic signal is necessary to keep the supersonic amplifier energized.

6. AA 106. Supersonic Receivers.

The supersonic receivers consist of two nickel magnetostrictive receivers mounted on top of a small steel float which is released by the mine a short time after reaching the bottom on laying. One of the receivers is mounted in a cone and has vertical directivity (trichter schwinger); the other receiver is mounted in a ring around the base of the cone receiver, and has horizontal directivity (ring schwinger). Figure 2 shows the directional characteristics of the two receivers. A vertical receiver; B horizontal receiver.

7. AA 106 - Float and Float Release.

Handling and releasing the float for the receivers was the chief difficulty encountered in the development of the AA 106. Several different types of shapes of floats were experimented with, but apparently no satisfactory one was developed. The main difficulty was to keep the float oriented properly when moored in a tideway on a short cable. Difficulty was also encountered in properly releasing the float from the mine. The float was carried inside cylindrical open-ended protective cover (schutz hube 10), and released a short time after the mine reached the bottom by the firing of a detonator. The method of mounting of the float on the mine before launching is shown in Figure 3.

CONFIDENTIAL

8. AA 106 - Arming.

The circuit of the AA 106 unit is shown in Figure 7. When the mine is laid, impact causes the master switch (3) to close its arming switch 3-6 and break its short-circuiting contact 1-6. If the temperature lies between -5°C and 35°C , thermostatic switch KTSE (73) is closed and battery (2) energized fuse delay switch (68). When (68) operates, with a short delay, it bridges 2-4 and 6-7, and fuse delay switch (69) is energized. When (69) operates, 1-10 and 7-8 are bridged. The float-releasing detonator is now fired through the auxiliary contacts of fuse delay switch (70). Detonator (75) fired and releases the float. When switch (70) operates the auxiliary contacts to the float-release detonator are switched out of the circuit as a precaution. If the mine is under 15 feet of water, hydrostatic switch (74) is open. If, at any time the hydrostatic pressure falls below 15 feet closure of (74) will energize fuse delay switch (72), and detonator (77) will fire after a delay due to (72) through leads 25 and 15. In addition, if the temperature of the water should go below -5°C , thermostatic switch KTSA will close and fire detonator (77). Switching over of (70) also starts clock (63). This clock is a mechanical clock which derives its motion from a disc-magnet balance-wheel influenced by a small coil which is energized in opposite directions as determined by a reversing switch operated by the balance wheel. Since one of the contacts is normally closed, the clock is self-starting and runs for the period to which set. Its maximum period is sixty days. When clock (63) has run off, it switches over and allows battery (1) to energize fuse delay switch (71). At the end of the period of (71), it operates and its multiple switches:

- (a) Connect the + side of the two batteries (1) and (2) to the plate circuit of the amplifier tubes.
- (b) Energizes the acoustic triggering circuit by connecting battery (67) through leads 16 and 0 to the microphone (54).

CONFIDENTIAL

9. AA 106 Triggering.

If an acoustic signal is detected, carbon microphone (54) transforms it into current variations. The variations appear on the secondary of transformer (55), and the signal is rectified full-wave by rectifier (58). The resultant DC is fed to relay B (61), which operates with a short delay due to condenser (60). Rectifier (59) is not an efficient rectifier and acts as an overload by-pass for relay B. B remains energized for the duration of sounds of 200 - 500 cps range. Operation of relay B closes its contact (b) which connects battery (67) to the heaters of the seven pentodes (5), (11), (16), (35), (41), (46) and (88).

10. AA 106 - Amplifier I.

Amplifier I consists of pentodes (5), (11) and (16) and their associated circuits. The grid of (5) is controlled by the signal received by the ring magnetostrictive receiver. The plate circuit is tuned by a parallel LC circuit to 25 kc. The output of the third stage (16) is rectified and fed to a network. Part of this rectified potential is fed back to the grids of (5) and (11) as a regulating potential as determined by potentiometer (21) through lead 35. The potential is also divided across resistors (23) and (24) and fed. Thus, the signal strength in the ring receiver (79) determines the sensitivity of Amplifier II to signals received by the cone receiver (80).

11. AA 106 - Amplifier II.

Amplifier II is identical to Amplifier I except that the control potential on the grids of its first two stages is derived from the output of Amplifier I instead of its own output.

12. AA 106 - Firing Circuit.

The firing circuit consists of a firing trigger system including pentode (88) and the actual switching circuit which includes relay C. Pentode (88) has its screen grid and suppressor grid connected together and, through lead 62, to a tuned LC circuit with condenser (86) and transformer (85). This circuit is tuned to approximately 1 kc. The control grid potential is normally such that the tube cannot oscillate. However, when a sufficiently

CONFIDENTIAL

12. AA 106 Firing Circuit (Cont'd).

large signal is received by the cone receiver and amplified at high enough sensitivity of Amplifier II, the grid potential of (88) is changed and the tube oscillates. The output of (88) is rectified by full-wave rectifier (49) and fed to the operating coil of relay A (51) whose sensitivity is approximately 1 ma. When A operates, contact (a) closes to lead 30 and connects relay C in series with thermistor (64) and the battery (2). Presuming fuse delay switch (92) to have operated during the arming cycle C now operates with a delay occasioned by the heating of the thermistor (64). When C operates, its switch c_z closes, and detonator (77) is fired by battery (2) in series with thermistor (64).

13. AA 106 - P.S.E. & Anti-Leak Device.

There is evidence in the circuit of the same type of galvanic P.S.E. and anti-leak device formerly used in the MA 101. In the MA 101 this took the form of two loops of insulated wire of dissimilar metals wrapped around the switch board with the fuse delay switches. If water entered the unit, a galvanic effect resulted between the two wires (Cu and Zn) and relay was actuated. This device appears in the AA 106. The cells are shown in the circuit and indicated (52). If these cells are activated, they energized relay A (51) in the opposite direction to that produced by rectifier (49). Contact (a) then closes to lead 25 and fires detonator (77) directly through thermistor (64).

14. AA 106 - Remarks.

The pentodes used in this circuit are all the same type: RV 2, 4 P 45. No other values are known at present. Some of the test characteristics are known and are shown in Figures 4, 5 & 6.

Prepared by:

W. C. HOLMES,
Lieut., U.S.N.R.

R. J. GRANZ,
Lieut., USNR.

C. J. OLENIACZ,
Lieut. USNR.

H. G. VOGEL,
Lieut., USNR.

SUPERSONIC FIRING FOR MOORED MINES (AA 4)

Horizontal Group
(e.g. 2 opposite
receivers wound in
opposition)

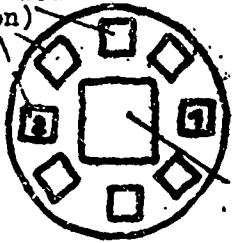

Vertical Receiver



CONSTRUCTION AND OPERATION OF THE RECEIVER GROUP

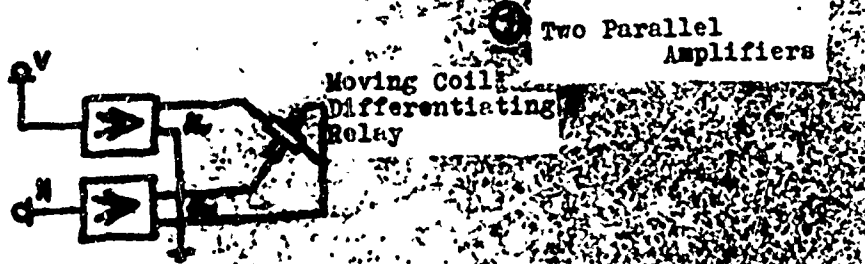

Two Parallel Amplifiers

Moving Coil
Differentiating
Relay



One Amplifier
With Alternate
Cam-Switching



One Amplifier
One Channel
With Frequency
Sum (V)
One Channel
With Frequency
Difference (H)

PRINCIPAL TYPES OF CIRCUIT

Fig. 2 Directional Characteristics - AA 1,6 Receivers

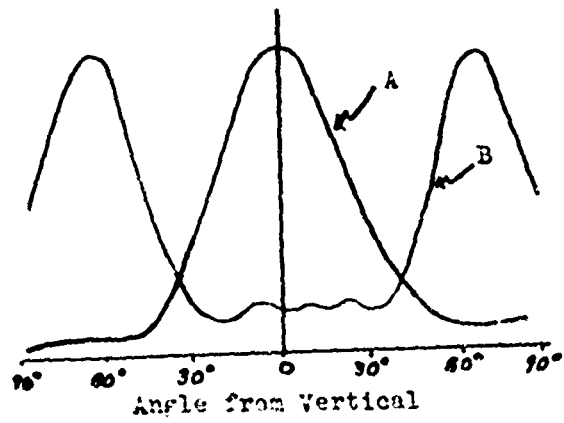
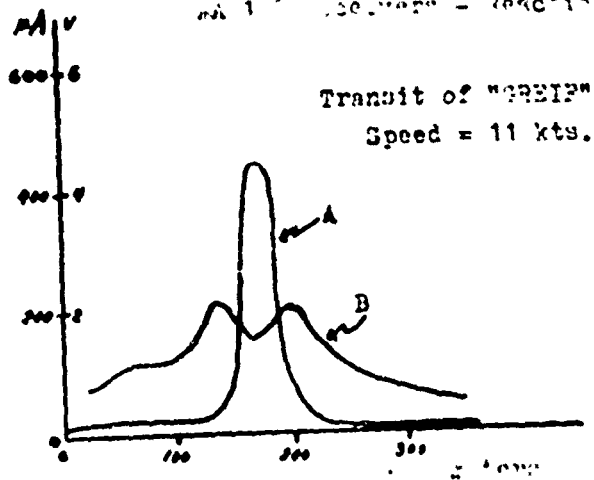

Fig. 4 AA 1,6 Receivers - Reaction to Ship Transit



MOUNTING OF A A 106
FLOAT IN BM 1000 HOR
BM 1000 L MINE

FIG. 3

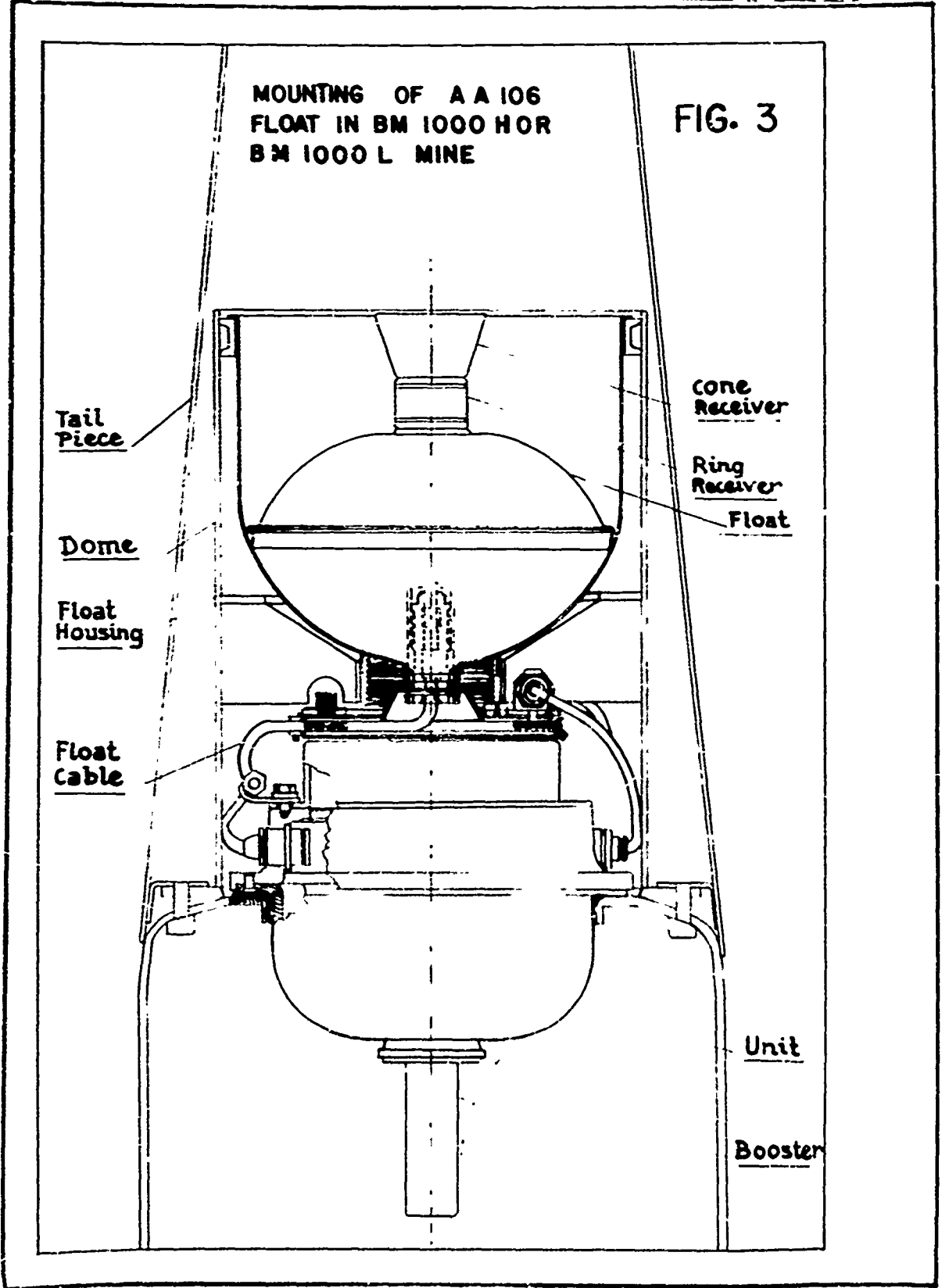

Fig. 5
AA 106 Receivers - Reaction to Ship Transit

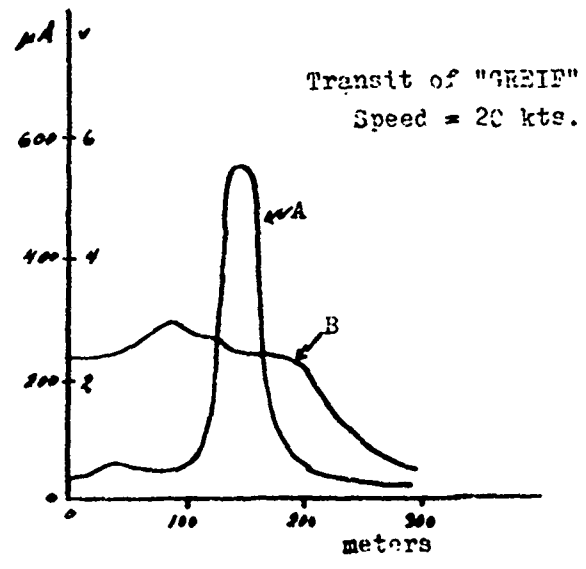
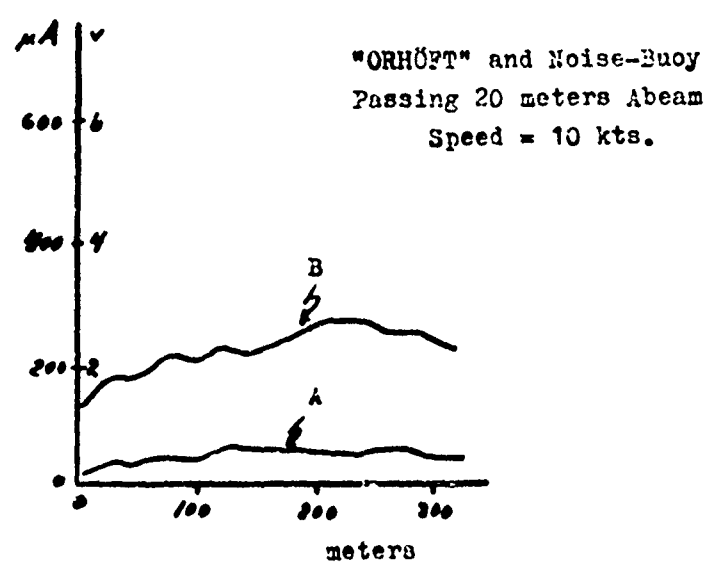
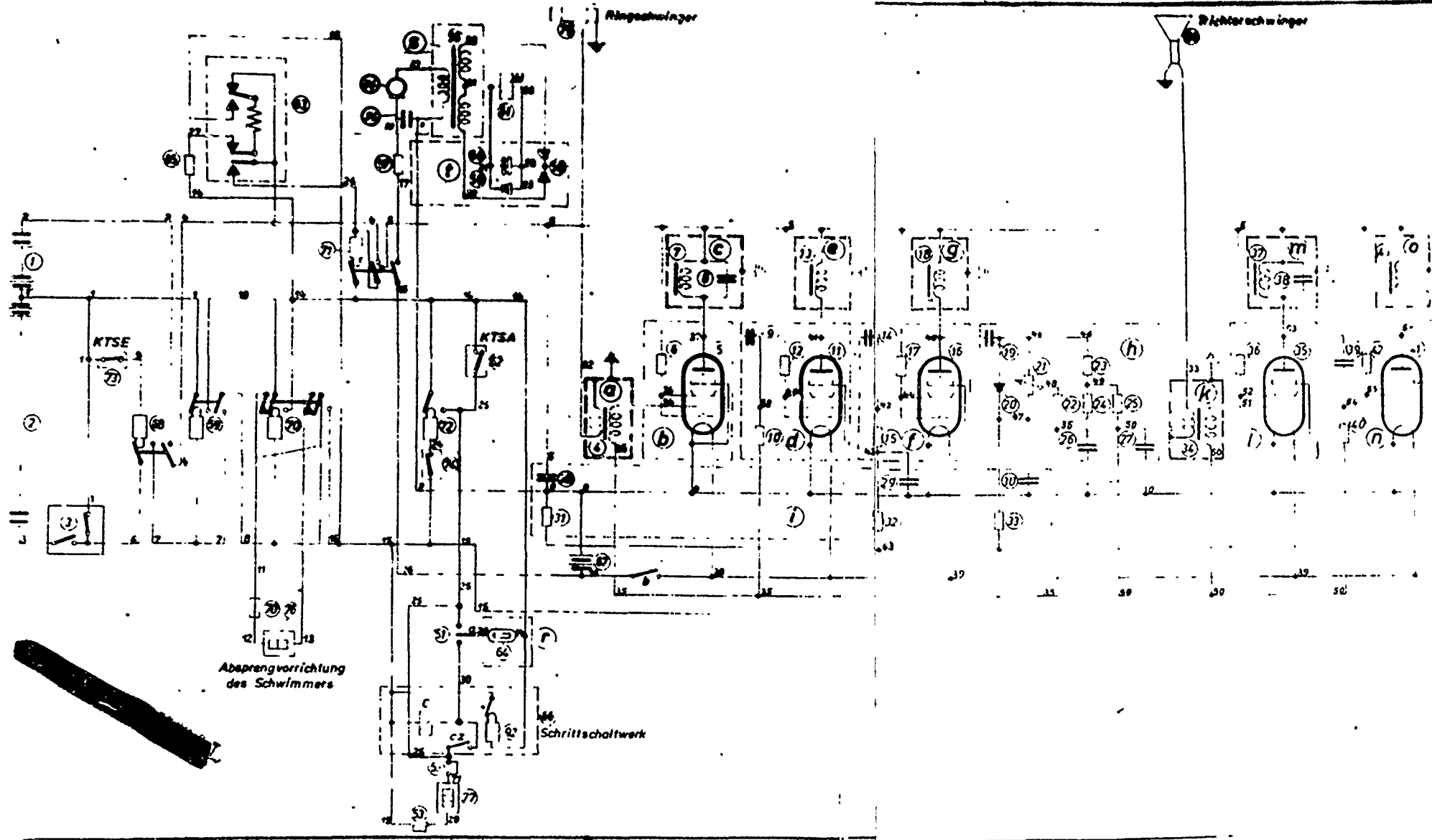
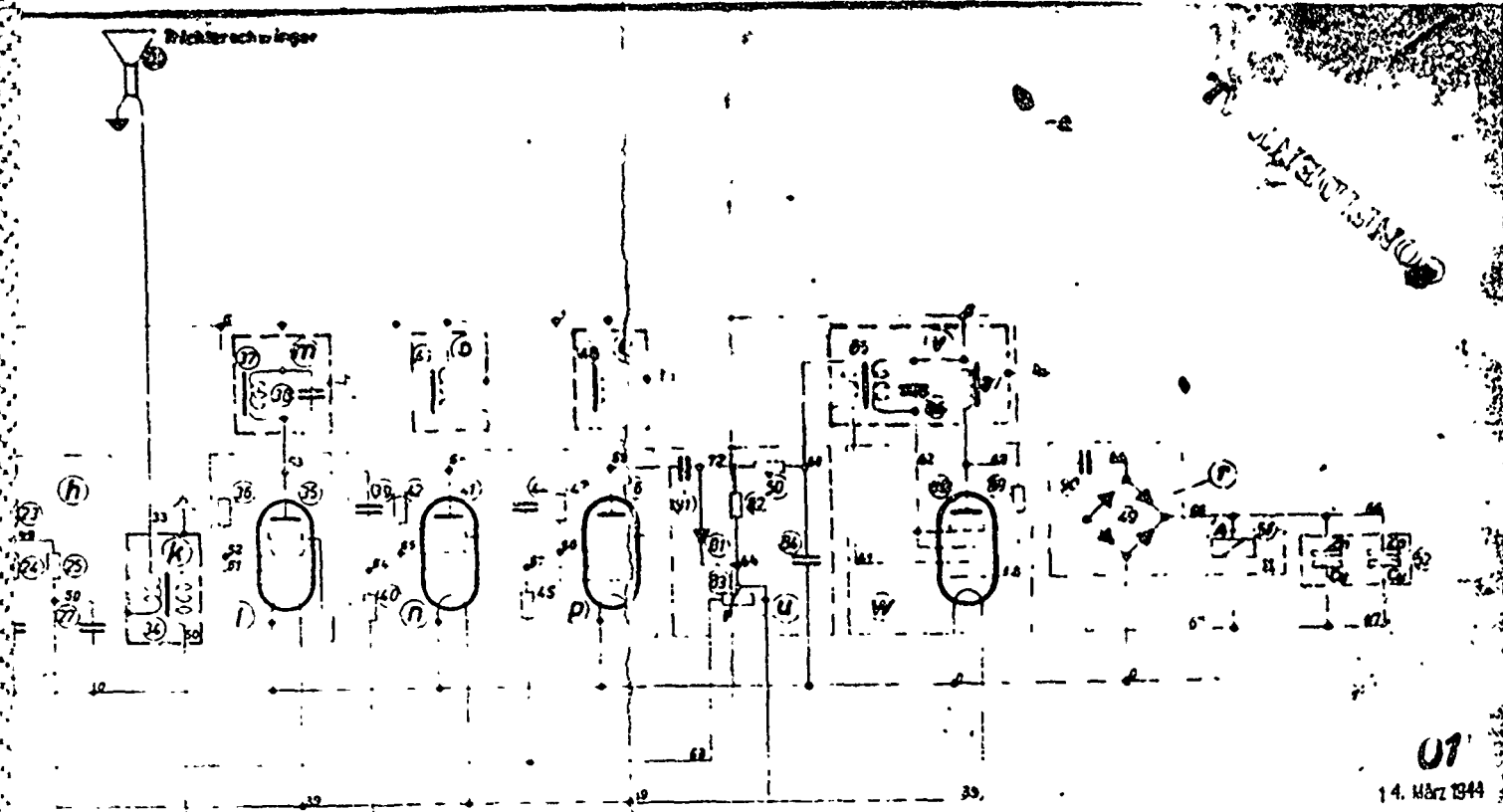

Fig. 6
AA 106 Receivers - Reaction to Ship
Passing Abeam





CONFIDENTIAL



01
14. März 1944

- Übersicht Bauelemente
1. 500V AC
 2. 500Ω
 3. 500V
 4. 500V
 5. 500V
 6. 500V
 7. 500V
 8. 500V
 9. 500V
 10. 500V
 11. 500V
 12. 500V
 13. 500V
 14. 500V
 15. 500V
 16. 500V
 17. 500V
 18. 500V
 19. 500V
 20. 500V
 21. 500V
 22. 500V
 23. 500V
 24. 500V
 25. 500V
 26. 500V
 27. 500V
 28. 500V
 29. 500V
 30. 500V
 31. 500V
 32. 500V
 33. 500V
 34. 500V
 35. 500V
 36. 500V
 37. 500V
 38. 500V
 39. 500V
 40. 500V
 41. 500V
 42. 500V
 43. 500V
 44. 500V
 45. 500V
 46. 500V
 47. 500V
 48. 500V
 49. 500V
 50. 500V
 51. 500V
 52. 500V
 53. 500V
 54. 500V
 55. 500V
 56. 500V
 57. 500V
 58. 500V
 59. 500V
 60. 500V
 61. 500V
 62. 500V
 63. 500V
 64. 500V
 65. 500V
 66. 500V
 67. 500V
 68. 500V
 69. 500V
 70. 500V
 71. 500V
 72. 500V
 73. 500V
 74. 500V
 75. 500V
 76. 500V
 77. 500V
 78. 500V
 79. 500V
 80. 500V
 81. 500V
 82. 500V
 83. 500V
 84. 500V
 85. 500V
 86. 500V
 87. 500V
 88. 500V
 89. 500V
 90. 500V
 91. 500V
 92. 500V
 93. 500V
 94. 500V
 95. 500V
 96. 500V
 97. 500V
 98. 500V
 99. 500V
 100. 500V

Überholt

2. Ausgabe und B Nr 2002. 28.10.43. Mo.
 AEG FDS/Sch Wirkschaltplan 563 SK B1002
 Berlin, den 2.11.43