

**JAPANESE  
LAND MINES,  
BEACH MINES,  
AND IGNITERS**

INTRODUCTION

TO

LAND MINES, BEACH MINES, & IGNITERS

The Japanese have several standard types of mines; however, a large number of those encountered are improvisations.

The standard mines, igniters, and a few of the more common improvised mines are included in this section.

CONFIDENTIAL

# JAPANESE LAND MINES BEACH MINES & IGNITERS

Our Designation

Armor Penetration Mine Type 99

Anti-Tank Mine Type 93

Japanese Designation

Type 99 Armor Penetrating Mine

九九年式石皮甲暴火雷

Type 93, Tank Mine

九三年式戰車地雷

<b>JAPANESE PULL IGNITERS FOR IGNITING SAFETY FUZE</b>	<b>RESTRICTED</b>	<b>PUBLICATION DATE: Sept. 1944</b>	
		<u>RED TYPE</u>	<u>BLACK TYPE</u>
	IGNITER LENGTH	2-3/4"	3-1/16"
	IGNITER DIAMETER	5/16"	5/16"
	SLEEVE LENGTH	1-18/32"	1-29/32"
	SLEEVE DIAMETER	7/16"	7/16"

**CONSTRUCTION**

RED TYPE

This igniter is composed of a brass body with a red plastic outer sleeve. At one end a screw cap is fitted with an eye for attaching a pull or trip cord. Attached to the inside of this cover is a short pull string which projects through a small pellet of friction ignition composition. The end of the igniter into which a safety fuze is crimped is covered with a piece of tinfoil to keep out moisture. The ignition pellet is contained in a brass tube crimped into the brass outer case.

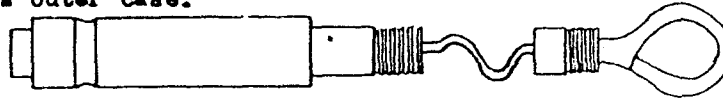

BLACK TYPE

This igniter differs only slightly from the red igniter. The brass case is slightly longer and the black plastic sleeve slightly larger. The sleeve over the case has fourteen depressions or rings around it to give the hand a firm grip. The red igniter has only one ring. As in the red igniters, the ignition pellet is contained in a brass tube crimped into the brass outer case. Tied through the eye on the cap is a heavy cotton cord to assist in pulling. The cap is not threaded but slides off. The fuze end and the cap are both sealed with tinfoil to keep out moisture.

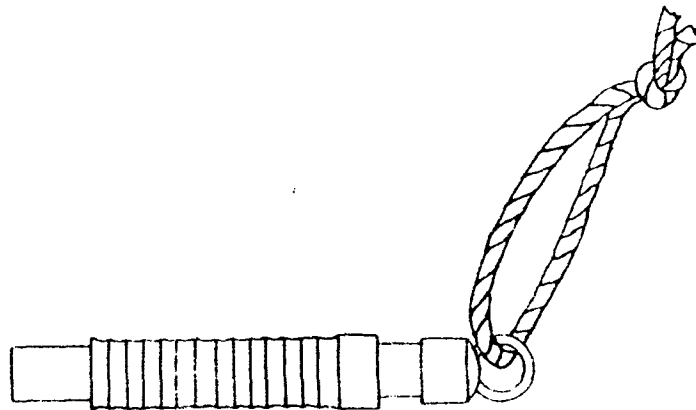

**EMPLOYMENT**

These igniters are designed to ignite safety fuze but can be used with a detonator to ignite trip wire booby traps.

**OPERATION**

When the sanded end of the pull string is drawn through the igniter composition it ignites and flashes through the igniter body.

**TO RENDER SAFE**

If employed in a booby traps, the pull line can be cut and the cap replaced on the igniter.

PUBLICATION DATE: May 1946

A box 8-5/8" x 4-1/4" x 3-1/4"

Tin

Silver

JAP  
IMP  
LAN

The mine consists of a rectangular box with a cover fastened by friction tape. Two holes are provided in the cover through which a grenade fuze or igniter projects. The grenade fuze projects approximately 1/2 inch. The location of detonator is unknown.

Contained in the box are one Japanese type (Type 1) and twelve blocks of 1/3 Aluminum Powder and 2/3 RDX. Each block is 1-1/2" x 3/4", wrapped in waxed paper. The grenade and blocks, 1/3 Aluminum Powder, 2/3 RDX, are firmly held in place by waxed paper.

Can be used as an anti-tank mine when fused with a grenade. With a pull or tension detonator it can be used as an anti-personnel mine or booby trap.

As an Anti-Tank Mine - Safety pin on fuze is removed. It is hit by a sharp blow the striker breaks through the primer. After a delay of 4 to 6 seconds the bursting charge then explodes setting off the mine.

As an Anti-Personnel Mine or Booby Trap - A pull detonator is inserted into the charge. When the detonator is pulled, the flash will fire the detonator which sets off the explosive and hand grenade.

When used as an anti-tank mine fused only with a fuze the mine can be rendered safe by removing the fuze, the grenade and removing the striker and spring.

When used with a pull igniter, out trip wire igniter from charge.

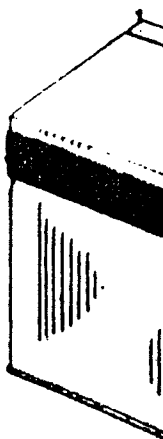
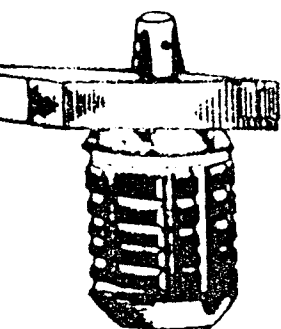

**JAPANESE  
BOOBY TRAP  
DEVICE**

RESTRICTED

PUBLICATION DATE: May 1946

OVERALL LENGTH . . . . . 6-3/8 in.  
 DIAMETER . . . . . 1-1/2 in.  
 WEIGHT . . . . . 2 lbs. 6 oz.  
 COLOR . . . . . Black  
 MATERIAL OF CONSTRUCTION . Cast iron

<b>DESCRIPTION</b>	The body is turned out of a solid 1 1/4 inch cast iron bar. It houses a spring-loaded striker which is held in position by a safety pin and a release pin. The safety pin fits thru the aft end of the striker projecting out of the upper part of the body. The release pin extends thru the body and the shoulder of the striker. The explosive train consists of a 6.5 mm cartridge case into which is wedged a blasting cap with the open end facing the cartridge cap. The cartridge case is wedged into the base of the firing device.
<b>EMPLOYMENT</b>	The threaded base fits the fuze cavity of a 20 lb. British bomb. This device is very easily adapted for booby traps.
<b>OPERATION</b>	Device screwed into bomb, pull wire attached to release pin, and safety pin removed. Pull on the wire removes release pin which frees the striker.
<b>TO RENDER SAFE</b>	If the release pin is still in position with a trip wire attached, insert a pin thru the safety pin hole, out the trip wire and unscrew the device from the bomb.

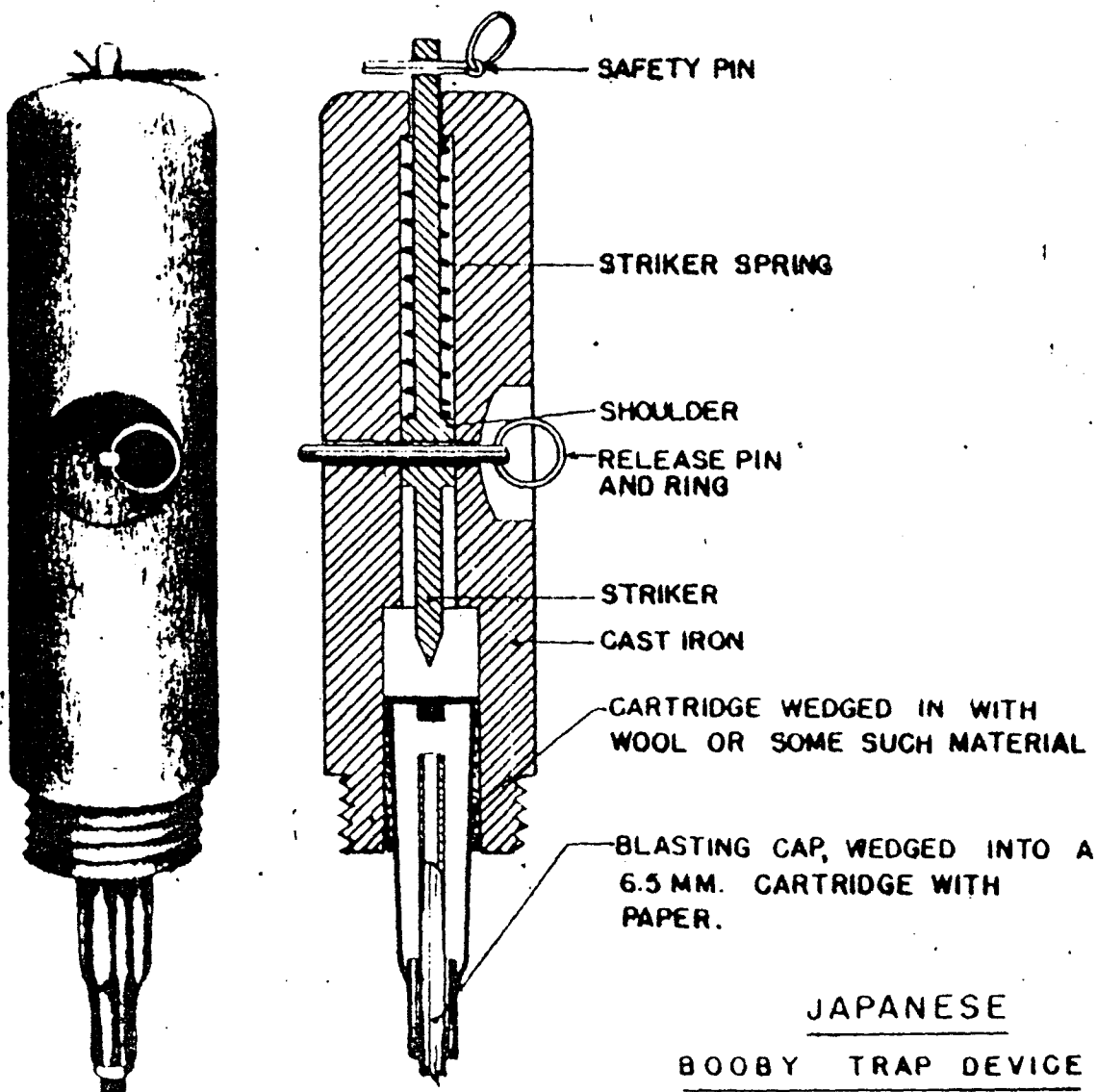

**JAPANESE  
BOOBY TRAP DEVICE**

RESTRICTED	PUBLICATION DATE Sept. 1944	<b>JAPANESE PREFABRICATED BOOBY TRAP</b>
LENGTH OF BOOBY TRAP	4½ in.	
DIAMETER OF BOOBY TRAP	3-7/16 in.	
LENGTH OF IGNITER INCLUDING BOOSTER	3-5/8 in.	
TYPE OF EXPLOSIVE	Believed to be picric acid.	

**DESCRIPTION** The container for the explosive charge looks like an ordinary tin can. The firing mechanism, a pull-igniter, is a single unit. It's body is a brass tube, which is threaded so that it can be screwed into the side of the container. It is reported that a loop of wire (or possibly a stout card) leads into the tube where it is attached to an igniter wire. This igniter wire in turn is embedded in a matchhead composition. Beyond the matchhead composition are a detonator and a booster charge.

**EMPLOYMENT** Used in the Arakan with a trip wire.

**OPERATION** When the igniter wire is pulled through the matchhead composition the flash ignites the detonator and in turn the booster and main charge.

**TO RENDER SAFE** Cut the trip wire and the booby trap is safe if the loop of wire is not pulled.

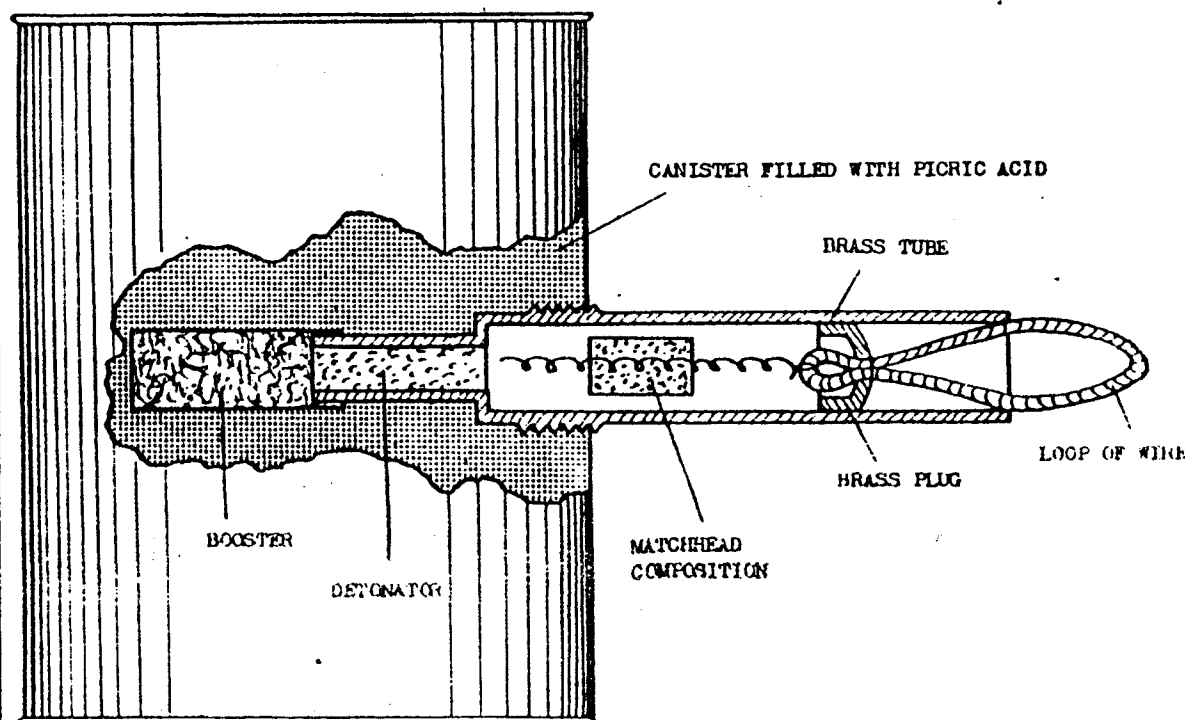

**JAPANESE PREFABRICATED BOOBY TRAP**

# JAPANESE PRESSURE & TRACTION LAND MINE

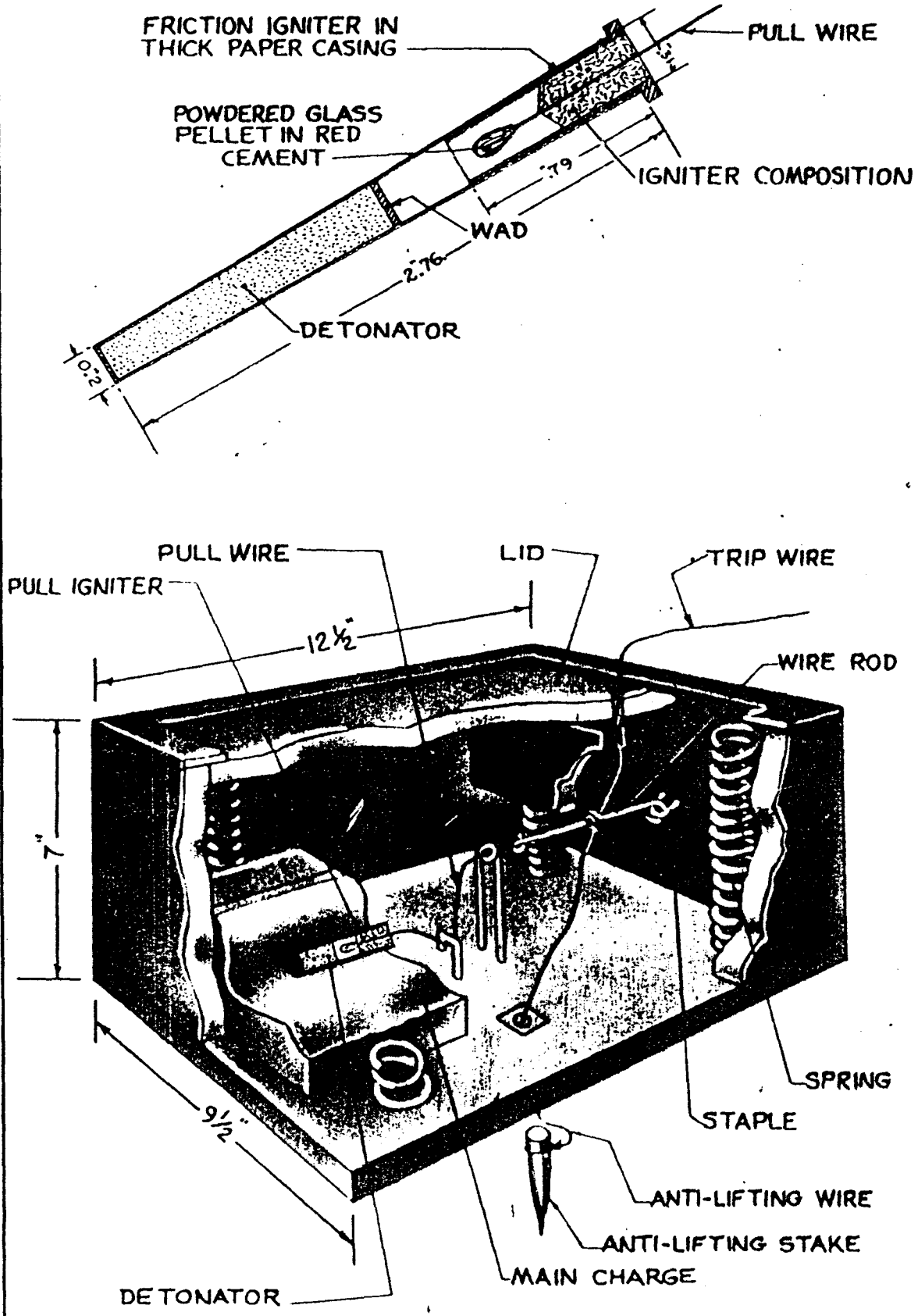

<b>RESTRICTED</b> <b>PUBLICATION DATE:</b> Sept. 1944		<b>JAPANESE</b>  <b>PRESSURE &amp; TRACTION</b>  <b>LAND MINE</b>
<b>OVERALL LENGTH</b>	12.5 in.	
<b>OVERALL WIDTH</b>	9.5 in.	
<b>OVERALL HEIGHT</b>	7 in.	
<b>WEIGHT OF FILLING</b>	2 lbs.	
<b>TYPE OF EXPLOSIVE</b>	Three blocks of Picric acid or TNT; the detonator of the igniter is inserted in the center block.	
<b>DESCRIPTION</b>	<p>The mine consists of a wooden box, the lid of which is held in place against the internal flanges on the top by four stout springs (one in each corner). A wooden block is secured by two bolts to the underside of the lid and serves to operate the pull igniter by pressure exerted on the cover.</p> <p>The explosive charge is in a separate container with the igniter and detonator inserted in the center block. A pull wire extends from the igniter over to the wire rod directly under the wooden block attached to the underside of the lid. To this wire rod are attached a trip wire which passes out through the cover to be secured to a tree or other suitable object and an anti-lifting wire attachment which passes through a hole in the base of the box and is secured to a peg. The igniter contains ignition composition and a pellet of powdered glass in red cement.</p>	
<b>EMPLOYMENT</b>	Used as an anti-tank or anti-personnel mine.	
<b>OPERATION</b>	The mine will function by either of three methods: pressure exerted on the lid, tension exerted on the trip wire, or by lifting the mine to operate the anti-lifting device. In all instances the wire rod is moved which pulls the wire leading to the igniter.	
<b>TO RENDER SAFE</b>	Cut trip wire and remove the retaining strips so that the lid can be lifted off. Cut the pull wire leading from the wire rod to the igniter and remove the igniter from the explosive container.	

# JAPANESE FRICTION-FUZED LAND MINE

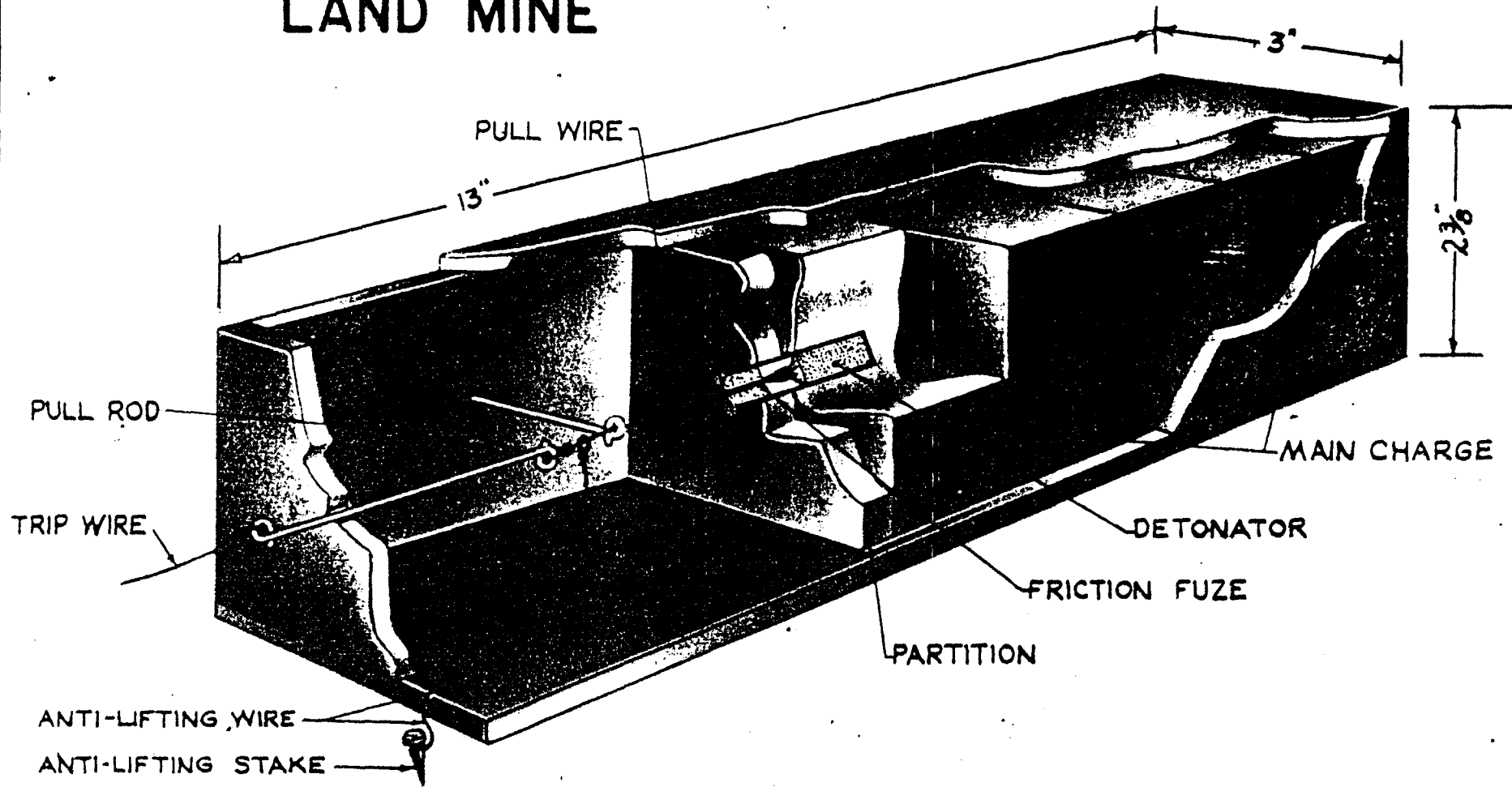

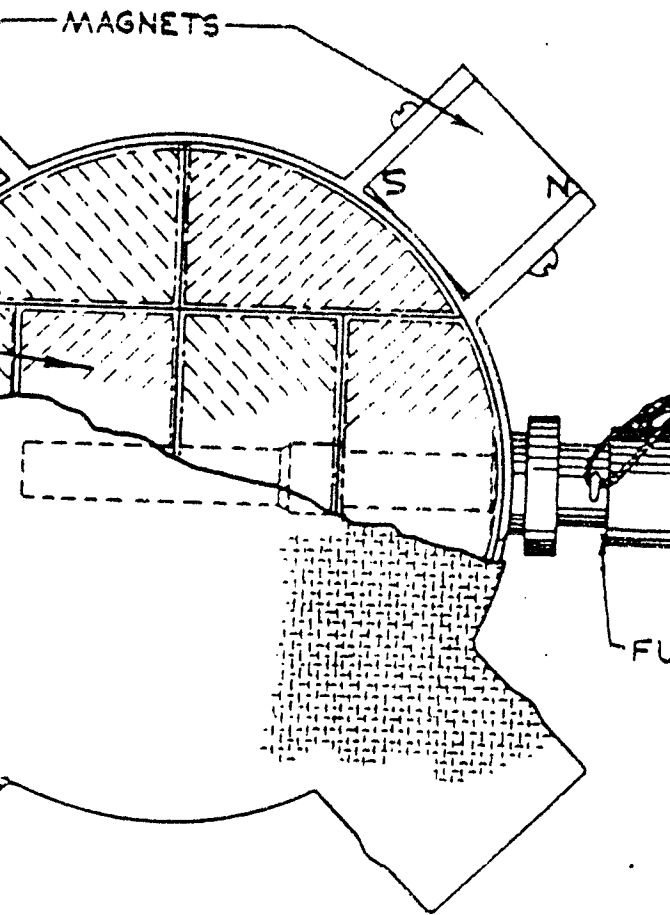

RESTRICTED PUBLICATION DATE: Sept. 1944		<b>JAPANESE</b>  <b>FRICTION-FUZED</b>  <b>LAND MINE</b>
OVERALL LENGTH	13 in.	
OVERALL WIDTH	3 in.	
OVERALL HEIGHT	2.37 in.	
WEIGHT OF FILLING	3.5 lbs.	
TYPE OF EXPLOSIVE	Five blocks of Picric acid or TNT; the detonator of the igniter is inserted in the end block.	
DESCRIPTION	<p>The mine consists of a wooden box, the sides of which are 0.59 inches thick. A wooden partition block inserted 4.25 inches from the unfilled end of the box, serves to hold the five blocks of explosive in place and also to secure the igniter in position. To the igniter is attached a trip wire which extends out through the end of the box and is secured to a tree or other suitable object. A safety device, the exact nature of which is unknown but reported to consist of a bottle-cap, is incorporated on the outside of the box at the point of egress of the trip wire. The anti-lifting device consists of a wire attachment which passes through the base of the box and is secured to a peg driven in the ground. Details of the igniter will be noted on page <u>176</u>.</p>	
EMPLOYMENT	The mine is buried 1 to 2 inches below the surface and used as either an anti-tank or anti-personnel mine.	
OPERATION	The mine can function by either a tension exerted on the trip wire or by lifting the mine to operate the anti-lifting device. In both instances the pull igniter is fired which in turn detonates the explosive charge.	
TO RENDER SAFE	Cut the trip wire and carefully remove soil from around mine. Cut any wires on the anti-lifting device and then remove lid of the mine. The igniter can be withdrawn from the charge.	

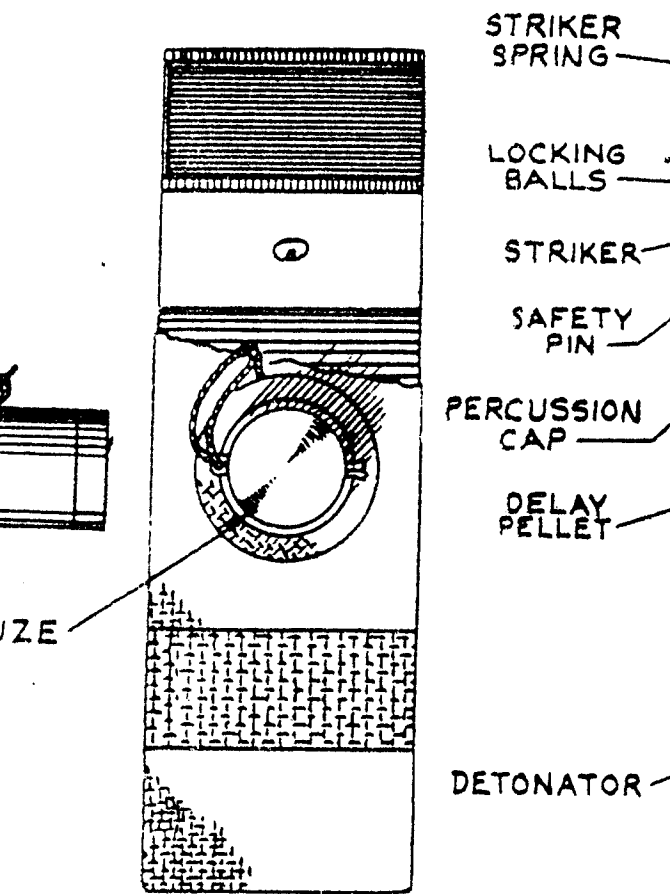

THESE ARMOR PENET

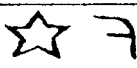

RATION MINE TYPE

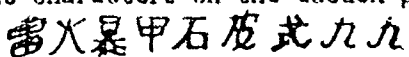
RESTRICTED PUBLICATION DATE: Sept. 1944		<p style="text-align: center;"><b>JAPANESE</b></p> <p style="text-align: center;"><b>ARMOR PENETRATION</b></p> <p style="text-align: center;"><b>MINE</b></p> <p style="text-align: center;"><b>TYPE 99</b></p>
OVERALL LENGTH	4.75 in. (circular)	
OVERALL WIDTH	1.5 in.	
TOTAL WEIGHT	2.5 lbs.	
WEIGHT OF FILLING	1.5 lbs.	
TYPE OF EXPLOSIVE	Eight cast blocks of 50-50 RDX-TNT shaped to form a circle. Individual blocks wrapped in wax paper.	
COLOR & MARKINGS	Khaki. Stencilled in black on body: 	
	On the opposite side is stencilled: 21A +  	
DESCRIPTION	<p>The mine resembles a canvas cloth bag, disc shaped, with a snap-fastened flap on the outer edge for inserting the eight blocks of explosive. Opposite the filling flap on the outer edge of the mine, is a metal adapter which is externally threaded to receive the fuze. Four equally spaced permanent magnets are attached by khaki webbing to the outer edge of the mine body. The mine is packed two to a wooden box complete with wooden shipping plugs in the fuze adapters. The fuzes are enclosed in tubular metal cases sealed with a paper band and tear string. For carrying on the field, the mines are packed individually in a khaki colored cloth pouch.</p> <p>The fuze contains two springs, a compression spring and a firing-pin spring, the latter of which is contained in a firing pin sleeve. Four steel retaining balls fit into holes in the fuze body and notches in the firing pin sleeve retaining the position of the firing pin. A fuze cap provides a base for the two springs and is grooved on the inside about 1/3 of the way up from its base. There is a safety pin which passes through the fuze body just below the base of the safety cap and between the striker and the percussion cap. The powder delay train threads into the base of the fuze body, and the detonator tube threads over the base of the delay train container.</p>	
EMPLOYMENT	Used as anti-tank or anti-vehicular mine, or against armor fortifications.	
OPERATION	The fuze is carried separately and is secured to the mine by a locking ring. In use, the safety pin is pulled, the fuze cap given a sharp rap, and the mine either placed on or tossed on armor plate within a range of ten feet. The fuze cap on being forced downward against the compression spring, simultaneously compresses the firing pin spring, and the groove in the cap moves opposite the retaining balls. The tension of firing pin spring forces the retaining balls out into this groove and the striker down onto the percussion cap.	
TO RENDER SAFE	Loosen the locking ring and remove fuze from the mine.	
REMARKS	<p>Test detonations of this mine indicate a distinct "Munroe Effect" at the junction of the inner edges of the explosive blocks. One mine will produce complete perforations in plate up to 1 inch. The mines are frequently coupled together and when so used, will penetrate 1.5 inch steel plate.</p> <p>The characters on the wooden packing case are:    (Translation: Armor Penetration Mine Type 99 (1939))</p> <p>The delay in the pyrotechnic delay train of the igniter varies from 8 to 10 seconds.</p>	



<b>RESTRICTED</b> Publication date: Dec. 1944	<b>JAPANESE AIR STRIP MINE IMPROVISED.</b>
<b>TYPE OF EXPLOSIVE:</b> 31 - 100 Kg. bombs and picric acid.	
<b>METHOD OF DETONATION:</b> Closing electrical circuit or by use of Demolition clock.	
<b>DESCRIPTION:</b> The bombs were stacked around picric acid blocks in which electrical detonators were inserted. The entire mine was under a turf covered piece of sheet iron that would close the circuit and fire the charge if the iron were lifted or depressed. A clockwork was also inserted to fire charge if iron was not disturbed.	

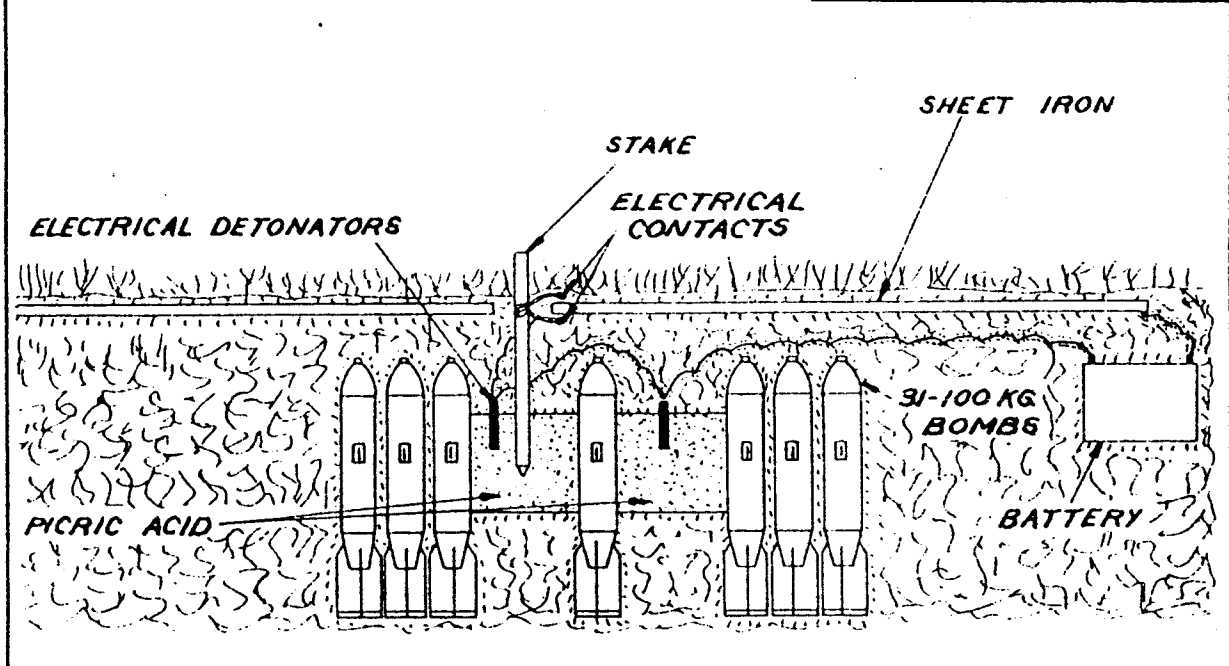

<b>RESTRICTED</b> Publication Date: Dec. 1944	<b>JAPANESE ANTI-TANK MINE IMPROVISED</b>
<b>TYPE OF EXPLOSIVE:</b> Two hand grenades, a 2 lb. prepared charge of picric acid, and a Model 99 Armor-Piercing mine.	
<b>METHOD OF DETONATION:</b> Pressure on board to fire the fuzes in the grenades. Sympathetic detonation rolled on for explosion of the main charge.	
<b>DESCRIPTION:</b> A prepared picric charge was laid on top of an armor-piercing mine and a hand grenade was set on the two sides. A board was laid over the top so that pressure would be transmitted to the fuzes of the grenades.	

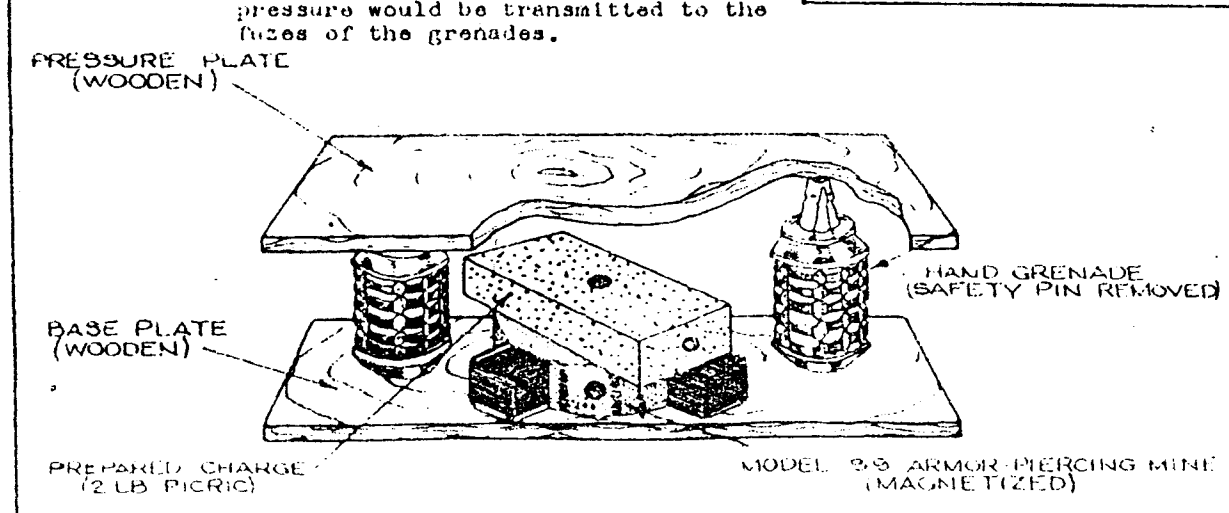

# JAPANESE ANTI-TANK

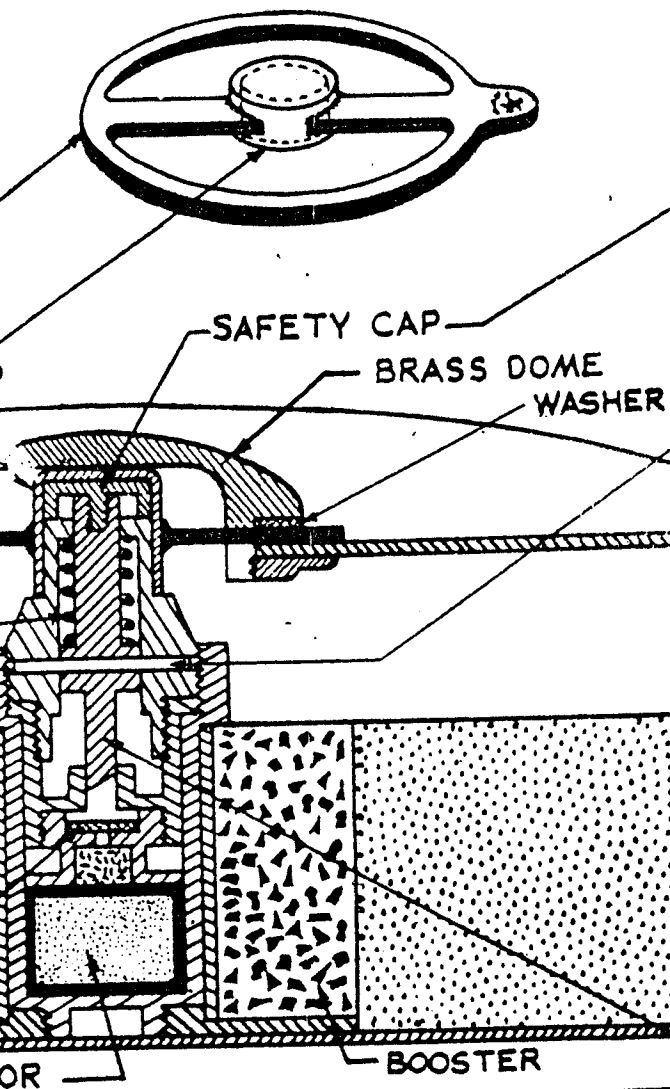

# MINE TYPE 93

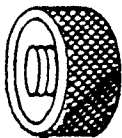

SHEAR WIRE

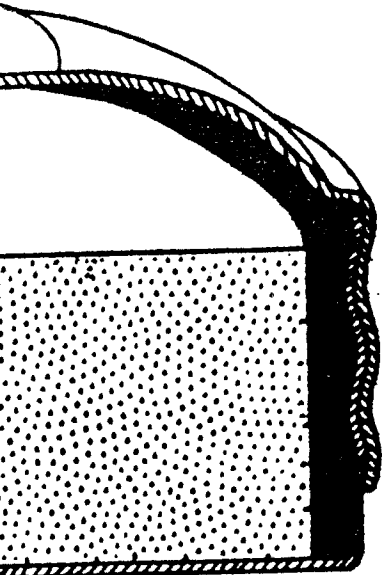

STRIKER

RESTRICTED PUBLICATION DATE: Sept. 1944		<b>JAPANESE</b>  <b>ANTI-TANK MINE</b>  <b>TYPE 93</b>
DIAMETER	6-3/4"	
OVERALL HEIGHT	1-3/4"	
WEIGHT	3 lbs.	
TYPE OF EXPLOSIVE	A solid ring main charge of cast picric acid with an inner ring booster of pressed powdered picric acid containing a central hole 5/8" diameter to house the fuze. The explosive is completely covered by a layer of paper, shellacked to the explosive and waxed externally.	
WEIGHT OF EXPLOSIVE	2 lbs.	
COLOR & MARKINGS	Olive-drab with a narrow red ring around the brass plug. The mine may have numerals (such as 16.9) in white on the top indicating a date.   meaning safe inscribed on the top of the safety cap and on the lug of the safety washer.	
DESCRIPTION	<p>The mine is circular with a slightly domed top, and flat bottom. It is constructed of an upper and lower section of sheet metal secured together by four corrugations in the walls. The overlap of the walls of the two sections is sealed with a bituminous base paint. The interior of the container is painted with a black enamel. Soldered on the inside of the bottom of the lower section is a brass disc 1-9/16" in diameter, having a threaded collar for the insertion of the fuze.</p> <p>The central hole in the upper section is reinforced with a brass collar threaded to receive the brass plug. A thin leather washer fits between the brass plug and the collar to seal the mine.</p> <p>Two brass rings are fastened to two opposite sides of the upper section by means of a soldered metal strip. Drag ropes may be fastened to the rings.</p> <p>The fuze assembly consists of a striker held under spring pressure by a shear wire, a percussion cap, a primary detonator, and a larger secondary detonator all incorporated in the fuze body which is threaded on the lower end to screw into the collar in the bottom of the mine. A safety cap is screwed into the upper end of the striker until the mine is laid. An additional safety feature is a brass cylinder with attached washer which fits over the brass safety cap and rest on top of the fuze body, the washer fitting under the leather washer of the brass plug.</p>	
EMPLOYMENT	Anti-personnel and anti-tank. The Japanese have two sizes of shear wire for this mine. One for anti-personnel use shears at 70 lbs., the other, for anti-tank use shears at 250 lbs. These mines have been found buried upside down with additional explosives placed beneath them to increase their effect.	
OPERATION	With the safety devices removed, any load on the cover of the mine causes the brass plug to press down on the striker. If the pressure is sufficient, the shear pin is sheared. This frees the striker which, under pressure of the spring, strikes the percussion cap which initiates the detonating system.	
TO RENDER SAFE	Unscrew the brass plug without moving or exerting any pressure on the mine. Screw on the brass safety cap and replace safety cylinder and attached washer if available, then unscrew the fuze. If no safety device is available, the fuze can be carefully unscrewed from the mine.	

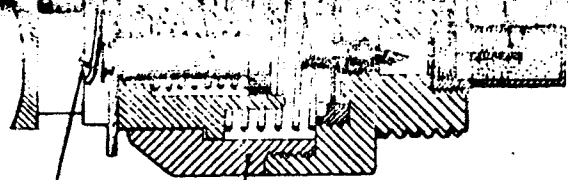

SAFETY PIN

COVER

JAPANESE  
TYPE  
LAND

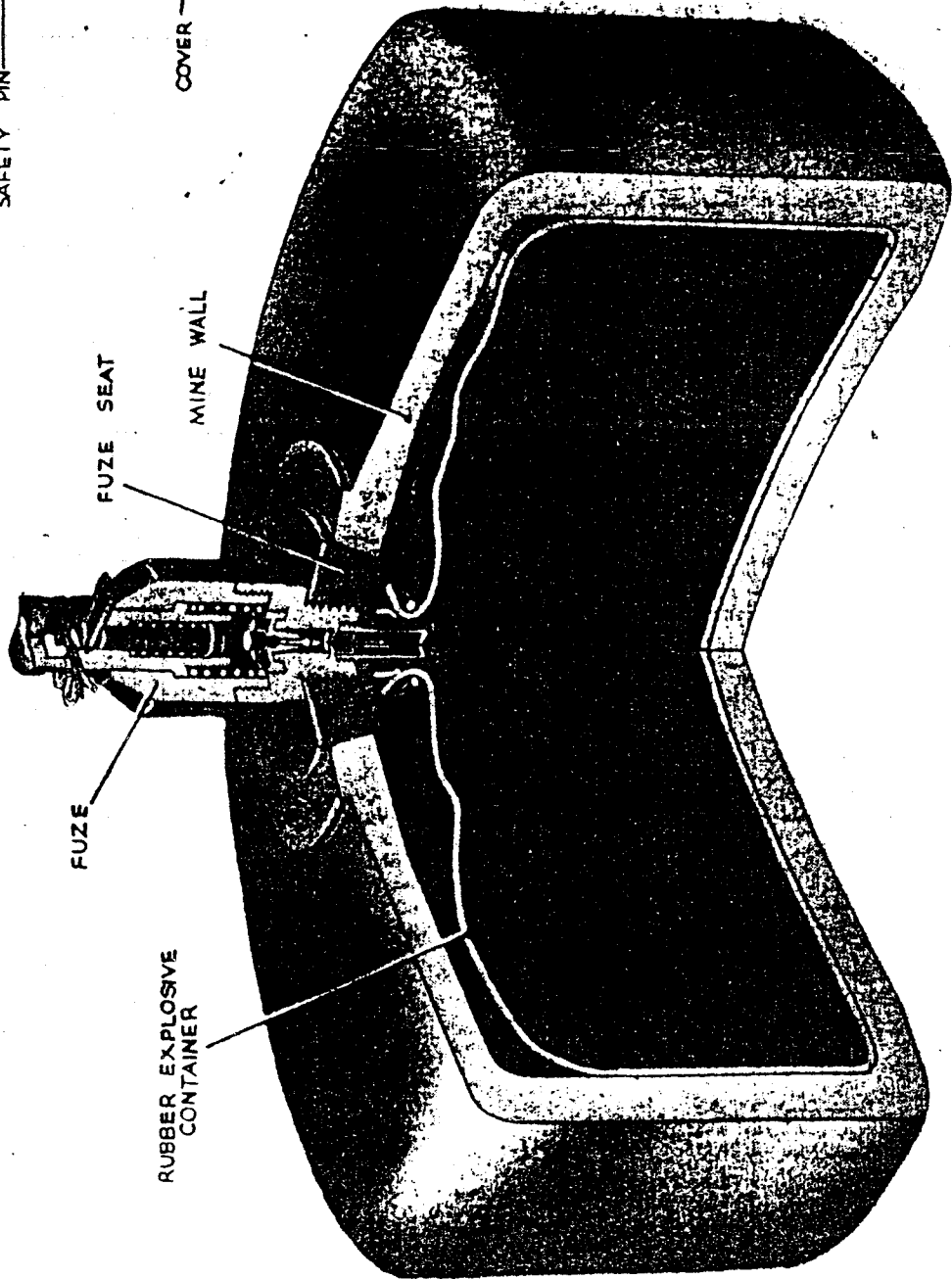

FUZE

FUZE SEAT

MINE WALL

RUBBER EXPLOSIVE  
CONTAINER

RESTRICTED		PUBLICATION DATE: May 1945		<h1 style="margin: 0;">JAPANESE LAND MINE TYPE 3</h1> <h2 style="margin: 0;">ANTI-VEHICULAR ANTI-PERSONNEL</h2>
DIAMETER		8.6"		
HEIGHT (w/o fuze)		4.13"		
HEIGHT (fuzed)		6.2"		
LENGTH OF FUZE		2.5"		
MATERIAL OF MINE WALL		Terra Cotta		
THICKNESS OF WALL		7/16"		
EXPLOSIVE FILLING		<p>Type 88. A captured document states that the bursting charge might also be either of these compositions: Ammonium Nitrate 50%, TNT 50%, or Ammonium Nitrate 90%, Dinitronaphthalene 10%.</p>		
WEIGHT OF EXPLOSIVE		4 lbs. 8 oz.		
TOTAL WEIGHT OF MINE		11 lbs. 6 oz.		
COLOR		Brown		
DESCRIPTION		<p>The mine is circular with a slightly concave top and a moderately convex base. The mine case is made of earth-colored terra cotta. The outer surface has a thin dull glaze while the inner surface is covered with a thin coat of lacquer.</p> <p>A rubber fuze seat is sealed in place in a hole in the center of the top of the mine.</p> <p>The explosive filler is contained in a light rubber bag inside the mine.</p> <p>The fuze body, cover, plunger and striker support are made of bakelite. The springs, percussion hammer, striker and the release fork are the only metal parts in the mine and with the exception of the release fork, all are contained inside the fuze.</p>		
EMPLOYMENT		May be used as an anti-vehicular or anti-personnel mine.		
OPERATION		<p>The mine is placed in the desired location and the safety pin is withdrawn. The fuze may then be rigged to fire either by pull or pressure.</p> <p>The percussion hammer located within the fuze is held in place by a release fork to which a trip wire may be attached. When the wire is pulled (22 lb. pull required), the fork releases the hammer which is forced downward by the hammer spring. The hammer hits the striker forcing it through its bakelite holder into the percussion cap.</p> <p>When pressure of 20-25 lbs. is applied directly on the head of the fuze the plunger spring and hammer spring are compressed causing the hammer head to exert pressure on the hammer release fork. When the plunger is further depressed a groove in its inner surface comes down to the level of the hammer release fork. The pressure of the hammer head cams out the fork. The hammer is released and hits the striker which in turn pierces the detonator.</p>		
TO RENDER SAFE		<p>If the mine is found with a trip wire attached to the hammer release fork and the fork is in the fuze, insert a wire in the safety pin hole, cut the trip wire and unscrew the fuze.</p> <p>If the mine is found with the hammer release fork missing the fuze must be assumed to be in a very dangerous condition. The mine should be blown in situ.</p>		

RESTRICTED

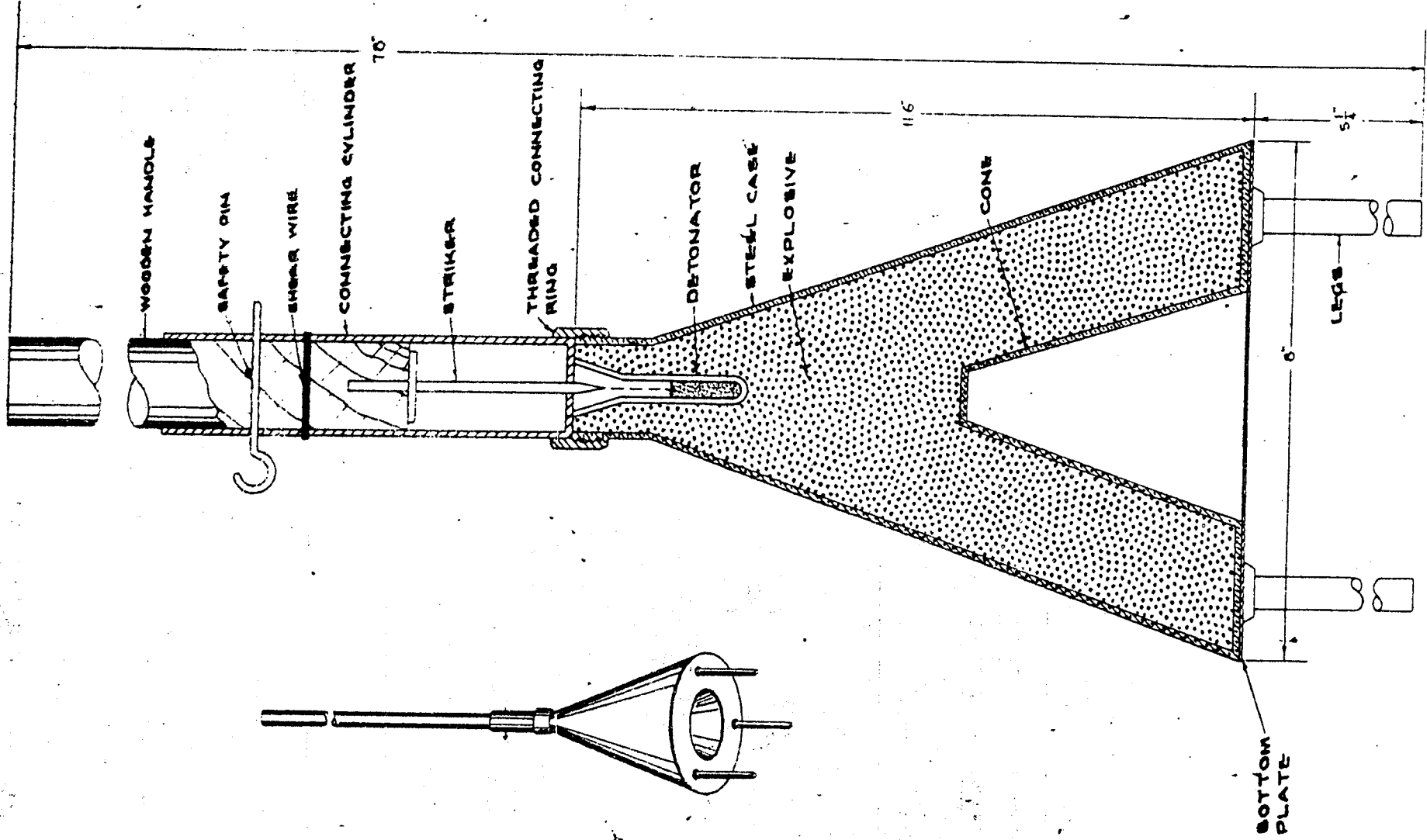

# JAPANESE LUNGE MINE

<b>RESTRICTED</b> PUBLICATION DATE: May 1946		<h1>JAPANESE LUNGE MINE</h1> <p><b>ANTI-TANK</b></p>
OVERALL LENGTH (including handle & legs)	78 in.	
TOTAL WEIGHT (mine body and handle)	14.5 lb.	
LENGTH OF BODY	11.6 in.	
DIAMETER AT BASE	8 in.	
WEIGHT OF BODY (including explosive)	11 lbs.	
LENGTH OF HANDLE	59 in.	
DIAMETER OF HANDLE	1-1/4 in.	
WEIGHT OF HANDLE	3.3 lb.	
EXPLOSIVE FILLING	Crude T.N.T.	
WEIGHT OF FILLING	6.6 lbs.	
DESCRIPTION	<p>The mine consists of a conical shaped hollow charge, with a wooden handle at the apex of the cone and three metal legs welded to the base.</p> <p>The conical charge is housed in a steel container. Fitted into the base of the charge in an inverted truncated cone designed to give the mine the increased power of penetration of this hollow charge. A well in the apex of the charge contains the detonator.</p> <p>The wooden handle has a steel striker fitted in one end. This end is encased in a metal cylinder and is held there by a safety pin and a copper shear wire. The cylinder is attached to the neck of the charge container by a threaded connecting ring.</p> <p>Three metal legs six (6) inches long are welded to the base of the charge container at 120° degree intervals. They guarantee the proper stand-off to obtain the maximum effect from the hollow charge.</p>	
EMPLOYMENT	Used as an anti-tank weapon. Capable of penetrating 6 inches of steel plating.	
OPERATION	The operator pulls out the safety pin, then uses bayonet tactics, the left hand at the center of the handle, the right hand at the after end, as he lunges forward when the legs of the mine strike the target the handle is driven forward breaking the shear wire, and the striker is driven into the detonator initiating the explosion of the mine.	
TO RENDER SAFE	If the mine is found with the safety pin removed, it can be considered dangerous. Secure the mine body, attach a line to the handle and pull it out from a safe distance.	

RESTRICTED

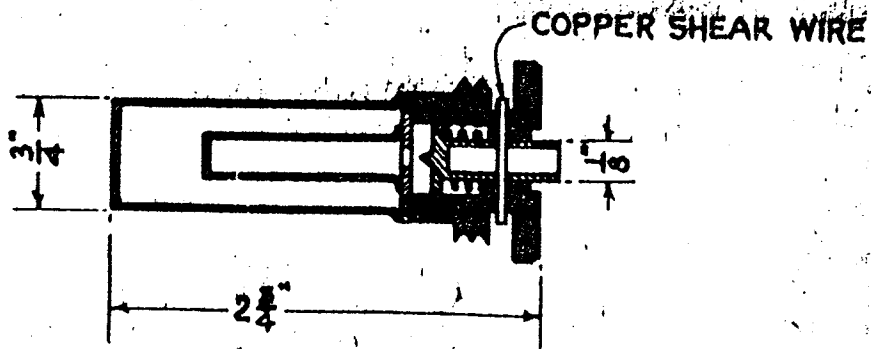
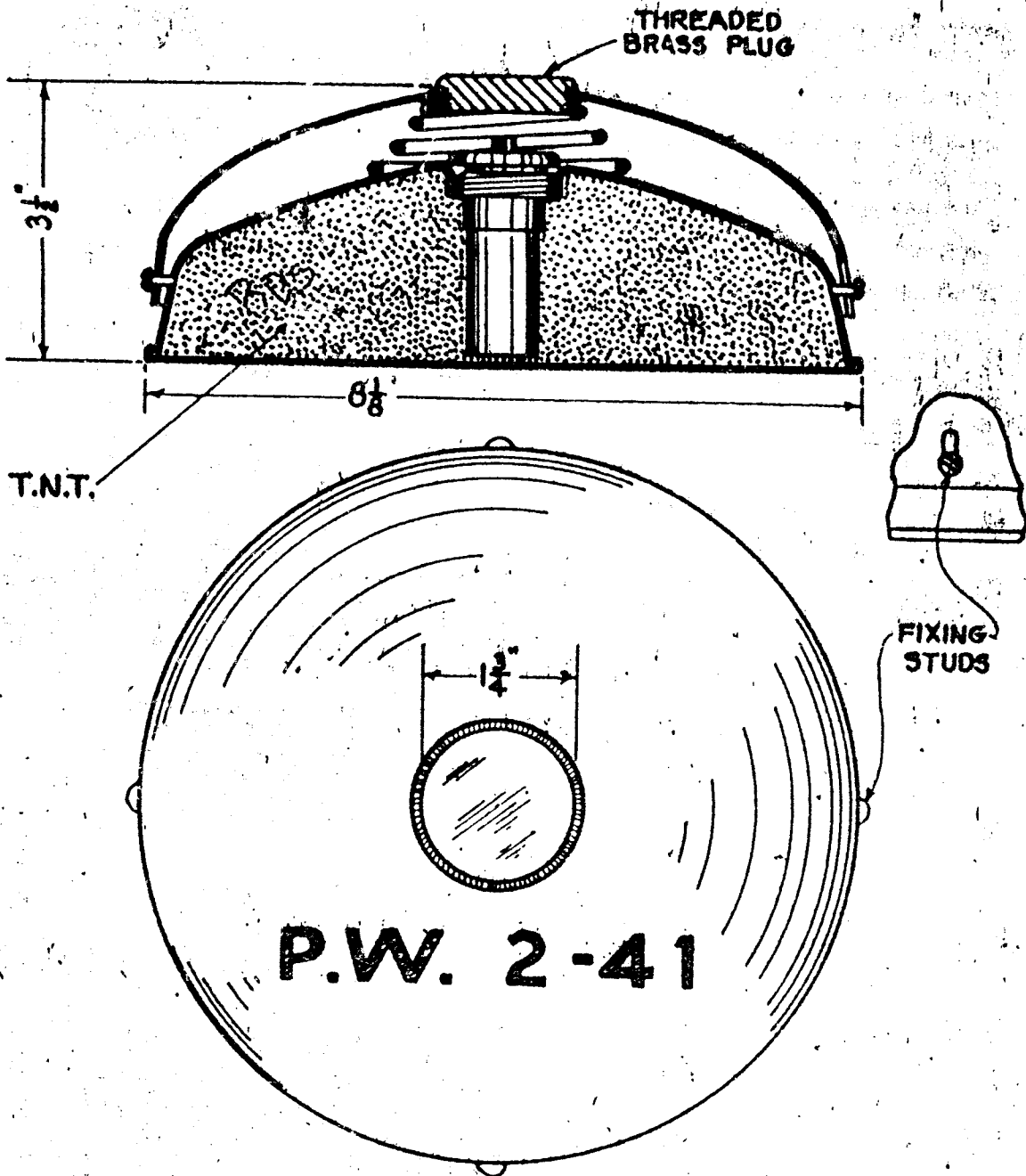

DUTCH

ANTI-PERSONNEL-ANTI-TANK MINE

RESTRICTED		PUBLICATION DATE: Sept. 1944		<b>DUTCH</b> <b>ANTI-PERSONNEL</b> <b>ANTI-TANK MINE</b> <b>P.W. 2-41</b>
OVERALL HEIGHT	3-1/2 in.			
HEIGHT OF BODY	2-7/8 in.			
DIAMETER OF BODY	7-7/8 in.			
DIAMETER OF COVER	8-1/4 in.			
WALL THICKNESS	5/32 in.			
WEIGHT OF FILLING	5-1/4 lbs.			
TOTAL WEIGHT	9-1/2 lbs.			
TYPE OF FILLING	T.N.T.			
COLOR & MARKINGS	Olive drab overall with "P.W. 2-41" in red across the top of both the cover and mine body. "P.W. 2-41" inscribed on fuze head.			
DESCRIPTION	<p>The body is of pressed steel construction with a crimped-on base. The cover is also pressed steel with four side slots corresponding with screw holes in the body which take the small fixing studs.</p> <p>In the center of the cover is a brass plug. A helical spring holds the cover away from the body. The igniter and detonator assembly screws into the top of the body of the mine. The striker is spring loaded and is held off the cap by the 1/16" diameter, soft copper shear wire. There is no safety pin.</p> <p>The detonator assembly consists of a detonator tube enclosed by an outer tube and a T.N.T. primer.</p>			
EMPLOYMENT	The Japanese use the mine mainly against personnel, laying them in narrow trails, on beaches, and at entrances to bivouac areas. Normally they lay it on top of the ground.			
OPERATION	<p>The movement of the cover is regulated by the size and position of the slots. Pressure on the cover is transferred from the brass plug on to the striker head, thus shearing the shear wire and allowing the spring to drive the striker into the cap thereby detonating the mine.</p> <p>A load of 50 lbs. is sufficient to shear the copper shear wire.</p>			
TO RENDER SAFE	Unscrew brass plug without exerting downward pressure on mine and unscrew and remove fuze. If the brass plug cannot be unscrewed, the cover can be removed by unscrewing the 4 fixing studs.			
REMARKS	<p>Several of these mines were recovered by U.S. personnel on Guadalcanal in February 1943.</p> <p>The marking "P.W. 2-41" stands for "Pyrotechnische werkplaats, Army Pyrotechnical Work Shop, Bandoeng, Java."</p>			

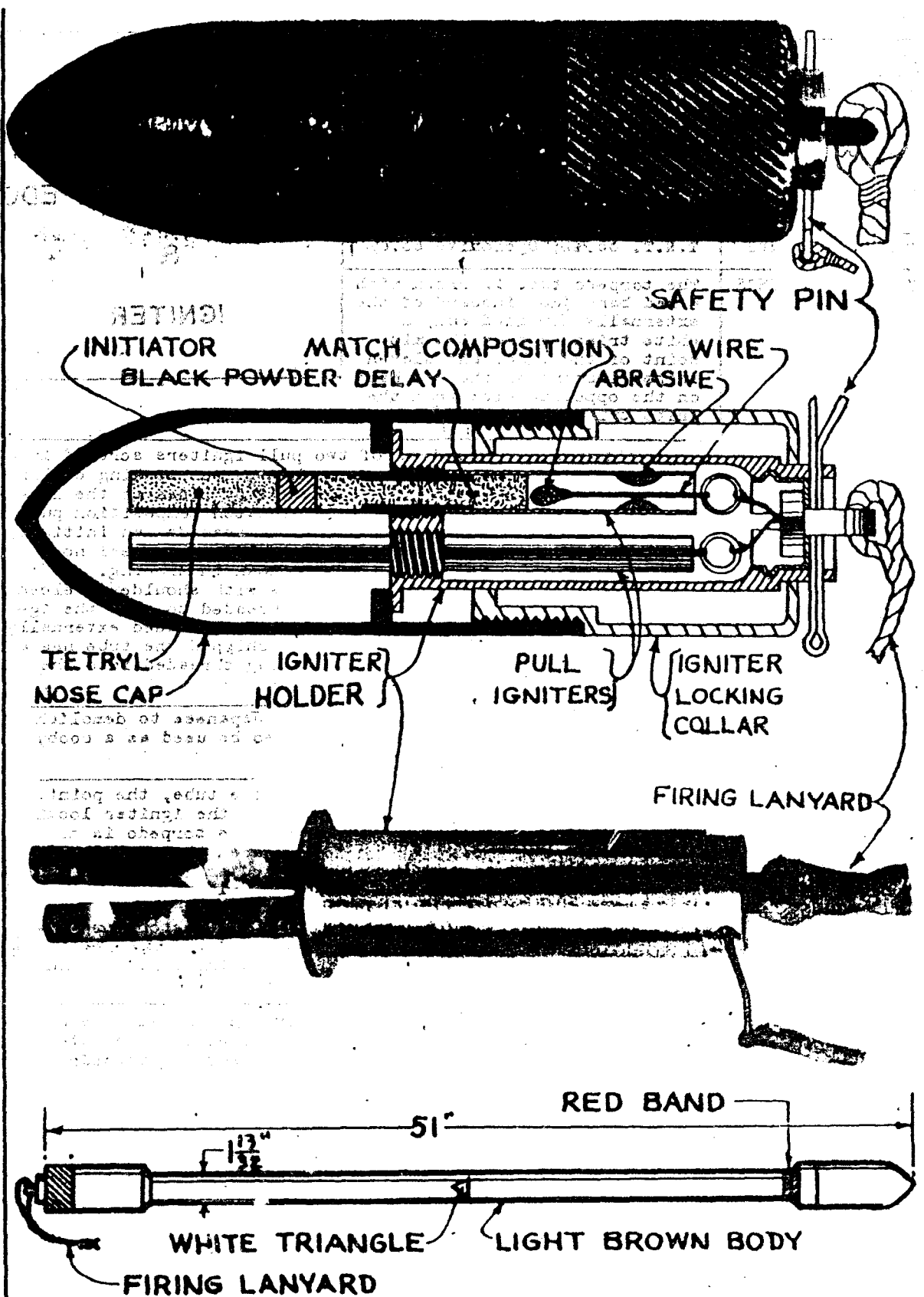

# JAPANESE BANGALORE TORPEDO AND IGNITER

RESTRICTED	PUBLICATION DATE: Sept. 1944	<p style="text-align: center;"><b>JAPANESE</b></p> <p style="text-align: center;"><b>BANGALORE TORPEDO</b></p> <p style="text-align: center;"><b>8</b></p> <p style="text-align: center;"><b>IGNITER</b></p> <p style="text-align: center;"><b>ROTATING</b></p>	
DIMENSIONS	See Drawing		
TOTAL WEIGHT OF TORPEDO WEIGHT OF FILLING	10 lbs. 3 lbs.		
TYPE OF FILLING	T.N.T. 36.4%; Cyclonite 63.6%		
COLOR & MARKINGS	The torpedo tube is brown with a red band just inboard of the externally threaded end, a white triangle near the mid-point of the tube, and eleven inches inboard of the red band on the opposite side from the white triangle is <sup>10</sup> / <sub>10</sub> [2]		
DESCRIPTION	<p>The igniter system consists of two pull igniters screwed into an igniter holder which fits into the igniter locking collar. The rings of the igniters are connected by lines to the lanyard holder. The igniters are simple match composition pull igniters with a black powder delay of 8 seconds, an initiant, and a base charge of tetryl. When shipping, the steel nose cap is threaded onto the igniter as shown in drawing.</p> <p>The torpedo proper is a steel tube with shoulders welded to both ends. One end is internally threaded to take the igniter locking collar and the other end is threaded externally to take the pointed nose cover. When shipped the tube has a cap screwed over one end and a male plug threaded into the other.</p>		
EMPLOYMENT	The bangalore torpedo is used by the Japanese to demolish barbed-wire entanglements. It can also be used as a booby trap, actuated by pull.		
OPERATION	<p>The caps are removed from the ends of the tube, the pointed nose cover is screwed on to one end, and the igniter locking collar is screwed into the other end. The torpedo is now ready for use. When the torpedo is placed the safety pin is removed and the firing lanyard is pulled. The safety pin has a cap which can take cover in the 8 seconds delay period.</p> <p>The pulling of the firing lanyard pulls a thread through the abrasive. The flash starts the black powder which after 8 seconds delay fires the initiant and tetryl base charge and the torpedo charge.</p>		
TO RENDER SAFE	If a torpedo is found with the safety pin removed, the safety pin (or substitute such as a nail, piece of wire, etc.) can be inserted in the safety pin hole, and the torpedo disassembled.		

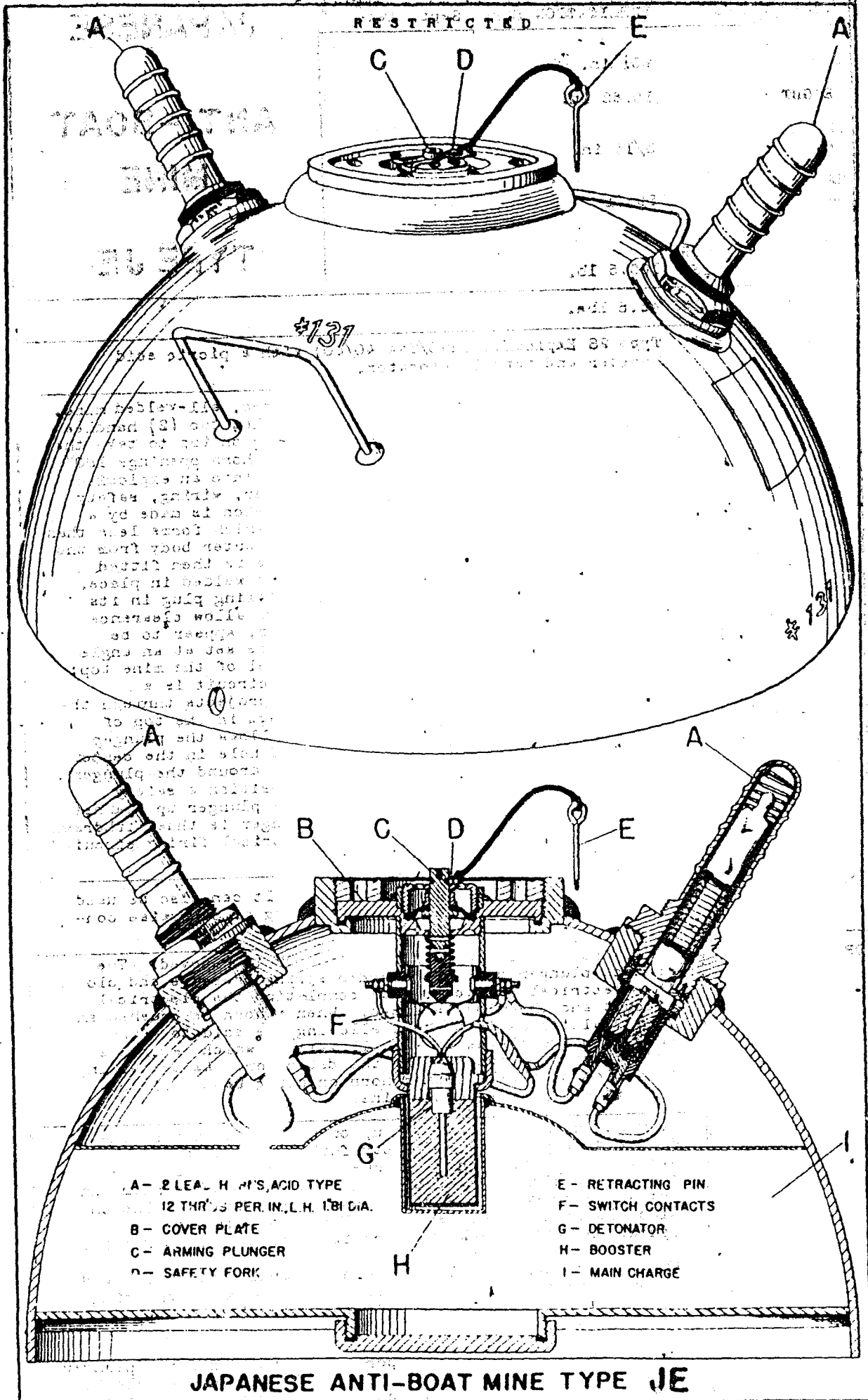

CONFIDENTIAL		PUBLICATION DATE Sept. 1944	<p style="text-align: center;"><b>JAPANESE</b></p> <p style="text-align: center;"><b>ANTI-BOAT</b></p> <p style="text-align: center;"><b>MINE</b></p> <p style="text-align: center;"><b>TYPE JE</b></p>
DIAMETER	20½ in.		
HEIGHT	10.62 in.		
THICKNESS OF WALL	3/16 in.		
MATERIAL OF WALL	Steel		
WEIGHT, LESS HORNS, DETONATOR BOOSTER & WIRING	106.5 lb.		
WEIGHT OF FILLING 46.5 lbs.			
TYPE OF FILLING Type 98 Explosive (MND/TNA 40/60) with a picric acid booster and tetryl detonator.			
DESCRIPTION	<p>This is a hemispherical, chemical-horned, all-welded mine. The outer body forms a hemisphere and has two (2) handles on its upper portion, a central opening on top to take the booster and safety switch, and two (2) horn openings 180° apart. The mine is divided internally into an explosive chamber and a chamber containing booster, wiring, safety switch, and horn electrodes. The division is made by a shallow, saucer-shaped steel section, which forms less than a hemisphere which is pressed into the outer body from the bottom and is welded in place. A plate is then fitted into the bottom of the mine and is also welded in place. This last-mentioned plate carries a filling plug in its center and is inset 13/16 of an inch to allow clearance for the plug. The horns, two in number, appear to be standard lead-acid mine horns. They are set at an angle of about 65° and project above the level of the mine top; treads are left hand. In the firing circuit is a spring-loaded plunger whose upper end projects through the safety-switch cover. A rubber diaphragm in the top of the cover insures watertightness but allows the plunger to move. There is a tapered, threaded hole in the center of the top of the plunger and a groove around the plunger near the top. Until the mine is in position a safety fork engages this groove and holds the plunger up against its spring. The inner end of the plunger is thus withdrawn from between two contacts in the electrical firing circuit and the circuit is incomplete.</p>		
EMPLOYMENT	Used on beaches as an anti-boat mine. It can also be used on land as an anti-tank mine by burying or otherwise concealing it.		
OPERATION	<p>After the mine is laid the safety fork is removed. The contact plunger moves down under spring pressure and closes the electrical contacts, thus completing the electrical circuit and the mine is armed. When a horn is crushed an acid vial inside is broken, allowing the acid to drain down onto two plates of a small battery which generates sufficient amperage to fire the detonator. As the wiring is series-parallel, either horn on being bent will act independently to fire the mine.</p>		
TO RENDER SAFE	<p>To make the mine safe, pull up on plunger on top of the mine and wedge out with safety fork. With a spanner wrench or a drift pin and hammer, remove the keeping ring over the arming mechanism. Pull out arming mechanism and cut white or yellow leads to detonator. Unscrew blue or black leads to safety switch. Either of these two operations will break the circuit. The mine is now safe.</p> <p>Unscrew booster from lower inside of arming mechanism and remove detonator from booster. (NOTE: Wooden centering ring for detonator has been found to swell and stick. Use a screw driver to break it out.)</p> <p>A booby trap could be incorporated so that when the plunger is retracted, the mine would fire. Precautions should be observed. The mine may be detonated by taping a blasting cap to one horn and firing the cap.</p> <p>The former U.S. designation was : JXIII The Japanese designation is : Small Type Land Mine</p>		

CONFIDENTIAL

# JAPANESE ANTI-TANK MINE

## TYPE JG

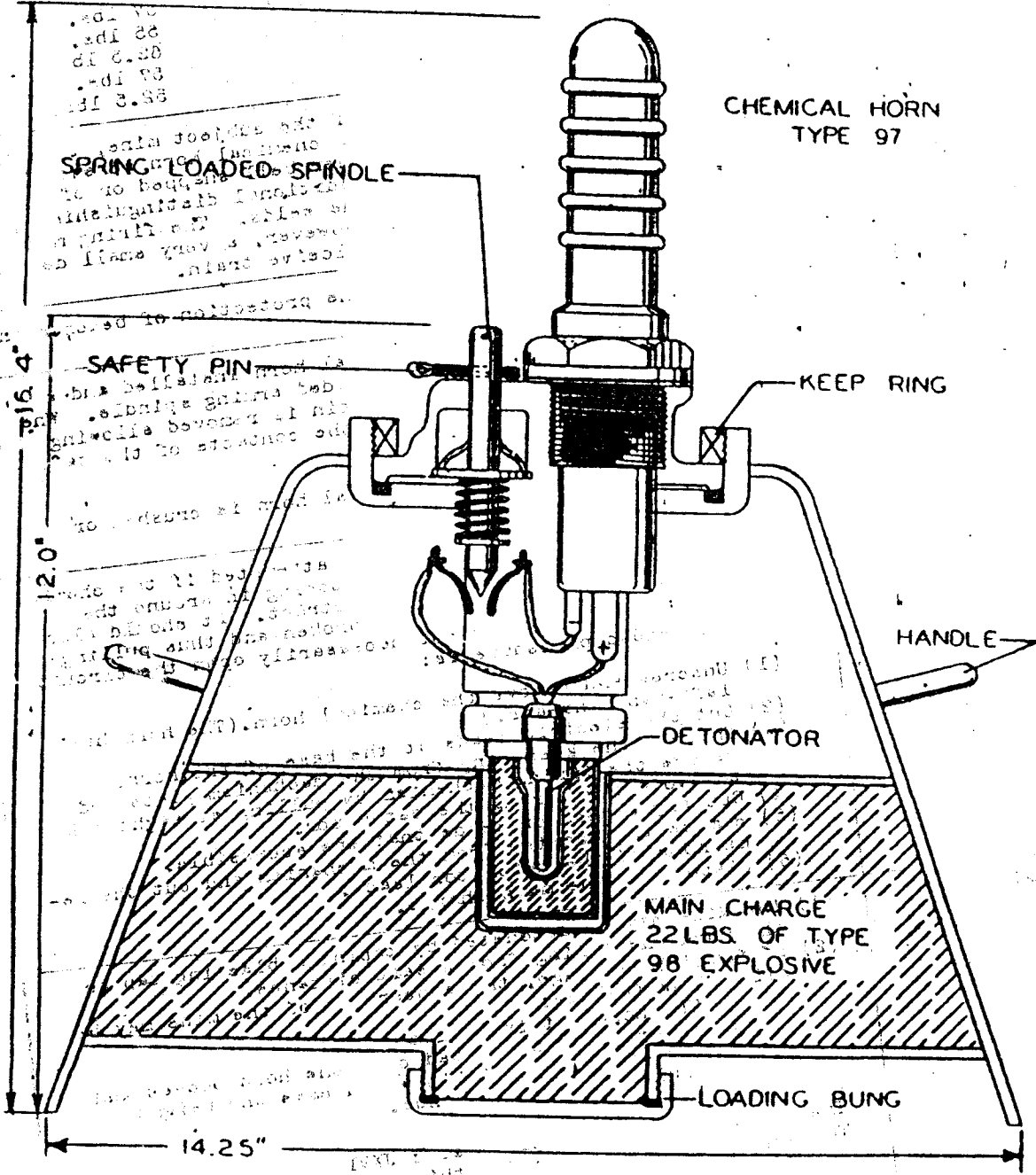

RESTRICTED PUBLICATION DATE: Sept. 1944		<b>JAPANESE</b>  <b>ANTI-BOAT</b>  <b>MINE</b>  <b>TYPE JG</b>	
METHOD OF ACTUATION	Chemical Horn		
WEIGHT OF EXPLOSIVE	22 lbs.		
TYPE OF EXPLOSIVE	HND-TNA 40/60 (Type 98)		
DIAMETER OF TOP OPENING	5.1 in.		
DIAMETER OF TOP	7 in.		
<b>MINE</b>	<b>DIAMETER OF BASE</b>	<b>HEIGHT</b>	<b>TOTAL WEIGHT</b>
#1	14-5/16 in.	10-1/4 in.	57 lbs.
#2	14-9/16 in.	10-5/16 in.	55 lbs.
#3	14-9/16 in.	10-5/16 in.	62.5 lbs.
#4	14-5/16 in.	10-1/4 in.	57 lbs.
#5	14-5/16 in.	10-1/4 in.	52.5 lbs.
DESCRIPTION	<p>There are five modifications of the subject mine, each of them being actuated by a single chemical horn, welded in to the top. The mines are either bell shaped or of a truncated cone shape with an additional distinguishing factor being the location of the welds. The firing mechanism is similar to the J-XIII; however, a very small detonator is used to initiate the explosive train.</p>		
EMPLOYMENT	<p>Used as an anti-boat mine for the protection of beaches and reefs.</p>		
OPERATION	<p>The mine is laid with the chemical horn installed and a safety pin through the spring-loaded arming spindle. When positioned properly, the safety pin is removed allowing the spindle to move down and bridge the contacts of the safety switch.</p> <p>The mine is fired when the chemical horn is crushed or broken.</p>		
TO RENDER SAFE	<p>Recovery of the mine should not be attempted if the chemical horn is bent or crushed. Sand filtering in around the spindle may make it difficult to retract. It should also be noted that the spindle may be broken and thus pulling up the arming spindle may not necessarily open the circuit. The recommended procedure is:</p> <ol style="list-style-type: none"> <li>(1) Unscrew and remove the chemical horn. (The horn has left-hand threads.)</li> <li>(2) Cut the electric leads at the base of the horn.</li> <li>(3) Unscrew the keep ring from the mechanism plate and remove the firing mechanism by pulling straight out to avoid fracturing the detonator.</li> <li>(4) Cut any detonator leads that are accessible.</li> <li>(5) Remove the booster from the mechanism and cut the remainder of the detonator leads.</li> <li>(6) Dispose of the main charge.</li> </ol>		
REMARKS	<ol style="list-style-type: none"> <li>(1) The Mine may be detonated by taping a blasting cap on the horn and firing from a safe distance.</li> <li>(2) If found in storage, the appearance of the mine may be altered as follows: <ol style="list-style-type: none"> <li>a) The horn not installed.</li> <li>b) A cover may be bolted over the horn pocket and the arming spindle in which case the height would then be 12 inches.</li> </ol> </li> </ol> <p>The former U.S. designation was JXVI  The Japanese designation for this mine is: Small Type Mine Model 2</p>		

