

# ACKNOWLEDGMENTS

Andrews .....	5-4	5-9	Hayes .....	4-21	5-18
Andrews (rpt.) .....	5-9	5-15	Huml .....	5-19	5-22
Barclay .....	5-9	5-14	Jeter (rpt.) .....	5-1	5-11
Barclay .....	5-14	5-21	Johnson .....		5-12
Bartlett .....	4-28	4-30	Keating .....	4-20	4-26
Bartlett .....	5-3	5-5	Keating .....	5-8	5-14
Bartlett .....		5-14	Kreiling .....	5-4	5-10
Bartlett .....		5-14	Kramig .....	4-19	5-14
Benoit .....	4-19	4-24	Lano .....	5-15	5-21
Benoit .....	4-23	4-28	Lawry .....		5-22
Benoit .....	4-24	4-30	Lewis (rpt.) .....	4-11	4-25
Benoit (copy) .....	5-7	5-14	Likowski .....	4-25	4-30
Benoit .....	5-14	5-16	Martin, J. E. (rpt.) .....	4-30	5-14
Bennett .....	5-15	5-23	Martin (rpt.) .....	5-6	5-17
Bell (rpt.) .....	4-14	5-7	McCabe (rpt.) .....	4-11	4-28
Bennett .....	4-15	4-28	McKenna (rpt.) .....	4-30	5-16
Bost (rpt.) .....	5-12	5-15	McAllister (rpt.) .....	5-10	5-23
Brown, C. K. (rpt.) .....	4-28	5-4	Merriman .....	4-11	5-24
Brown, C. K .....	5-2	5-5	Mitchell .....	4-10	5-1
Brown .....	5-8	5-11	Moorman .....	5-12	5-14
Bryan .....	4-14	5-18	Moorman (rpt.) .....	5-10	5-15
Bruggink .....	5-15	5-22	Murphy (rpt.) .....	4-30	5-14
Brubaker .....	5-22	5-24	Murphy (rpt.) .....	4-28	5-17
Callery .....	4-28	5-2	Murray .....	4-17	4-25
Carlin .....	5-5	5-14	Norris .....	5-7	5-21
Carleton .....	5-7	5-21	Obenauf .....	4-25	5-10
Carnahan .....	4-21	4-26	OLK .....	5-3	5-8
Carnahan (rpt.) .....	4-21	4-27	Pepelnjak .....	4-27	5-8
Chilton .....	4-19	5-4	Peterson .....	4-23	5-15
Conway (rpt.) .....	4-30	5-4	Patton (rpt.) .....	3-31	4-26
Crossley .....	4-16	4-28	Patton .....	4-13	4-26
Conway .....	4-28	4-30	Patton .....	4-25	5-4
Conway .....	5-3	5-5	Patton (rpt.) .....	4-30	5-16
Crossley (rpt.) .....	4-13	5-7	Patton (rpt.) .....	5-7	5-16
Crossley (rpt.) .....	4-9	5-7	Patton (rpt.) .....	5-8	5-16
Cronin (rpt.) .....	4-30	5-14	Patton (rpt.) .....	5-11	5-23
Dawson (rpt.) .....	4-15	4-30	Puchalski .....		5-22
Dehnel .....	4-30	5-19	Schaible .....	4-18	4-30
Duncan .....	5-17	5-21	Schenkkan (rpt.) .....	4-23	4-25
E. I. L. (Balboa) (rpt.) .....	4-20	4-30	Schenkkan .....	5-7	5-12
Ethridge .....	4-21	5-4	Schenkkan (rpt.) .....	5-21	5-23
Faass .....	4-24	5-2	Scott, H. P. .....	4-23	4-27
Faass (rpt.) .....	4-25	5-4	Scott, H. P. (rpt.) .....	4-23	4-30
Faass (rpt.) .....	4-30	5-15	Scott (rpt.) .....	5-7	5-16
Finch .....	4-18	4-24	Seip .....	4-17	4-30
Finch (rpt.) .....	5-7	5-16	Shaber .....	4-18	4-30
Fisher (rpt.) .....	4-11	4-28	Smith, H. E. .....	4-24	4-30
Franklin .....	5-3	5-5	Spartz (rpt.) .....	5-1	5-11
Freeman (rpt.) .....	4-23	5-8	Stitt .....	5-11	5-14
Graham (rpt.) .....	4-30	5-10	Throner .....	5-10	5-15
Grice .....	5-4	5-21	Tuttle (rpt.) .....	4-30	5-14
Hansen (rpt.) .....	3-31	4-26	Taylor, M (rpt.) .....	4-20	5-1
Hansen .....	4-25	5-4	Wagner .....	5-18	5-21
Hanson (rpt.) .....	4-30	5-16	Weeks .....	4-24	4-30
Hanson .....	5-7	5-16	Weems (rpt.) .....	4-26	5-5
Hanson (rpt.) .....	5-8	5-16	West (rpt.) .....	4-26	5-14
Hanson (rpt.) .....	5-11	5-23	Whittemore .....	4-22	5-1
Hamilton (rpt.) .....	5-1	5-14	White (rpt.) .....	5-9	5-18
Hayes .....	4-2	5-2			

CONFIDENTIAL

# Intelligence

BULLET | N

U. S. NAVY BOMB DISPOSAL

JUNE 1945, VOL. 2, No. 1



U. S. NAVY BOMB DISPOSAL

# Intelligence

BULLETIN • JUNE 1945 • Vol. 2 No.1

## CONTENTS

Japanese Balloons .....	
Rocket Wrench .....	
Japanese Propellants .....	
Japanese Chemical Fuzes .	
VT Impact Feature .....	16
Russian Bombs .....	18
Japanese Navy Fuzes .....	21
New Type Japanese Barrage Mortars .....	26
Nomenclature .....	27
Acknowledgments .....	28



This document is issued to graduates of a course in Bomb Disposal, by the Officer in Charge, Navy Bomb Disposal School, under authority of Bureau of Ordnance letter F4I —6 (L) of 22 April 1944. It is for information and guidance only and is not a Bureau of Ordnance Publication. It should be destroyed (when of no further use to Bomb Disposal Personnel.

# JAPANESE BALL'S

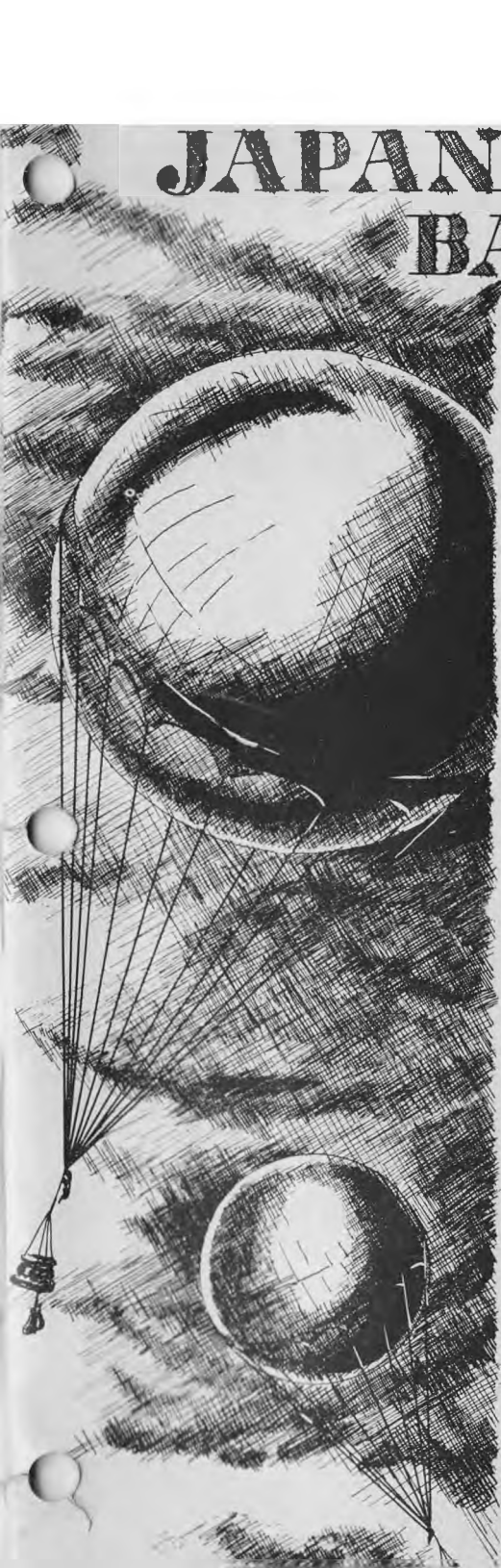

In view of the increasing number of sightings of balloons, and the probability that Bomb Disposal personnel may be called upon to dispose of them as we come nearer to the supposed launching areas, the following compilation of known facts relative to this item of Japanese warfare is given.

This is not to be considered an official and final summary on the Japanese balloon but merely a compilation of data extracted from various reports dealing with recovered balloons.

The following is a general description that will fit most of the balloons recovered thus far.

It is a free, 32-foot 8-inch, spherical balloon, made from two- to five-ply of rice paper which has been paraffin treated. Most of the balloons are a yellowish-white in color, a few have been a pale greenish hue and yellowish-white with the latter color predominant.

A curtain made from the same material as the envelope and consisting of four thicknesses of the two- to five-ply paper, is secured to the balloon one-third distance from the equator to the bottom. Nineteen manila lines 38 feet in length are secured to the curtain and lead down to a metal ring from which is suspended an automatic ballast release device.

Fitted to the base of the balloon is an automatic pressure release valve which allows the hydrogen gas to escape as the barometric pressure decreases, thus limiting the altitude to which the balloon will ascend.

Attached to the surface of the balloon above the curtain is a bag of magnesium and potassium chlorate flash powder. Inserted in one end of the bag is a blasting cap to which

is crimped 50 feet of safety fuse which leads down to the automatic ballast release device. The bag of flash powder is intended to be used as a self-destroying device. After the ballast release device has dropped all the load carried, the long length of safety fuse is ignited and fires the flash bomb destroying the envelope by igniting the hydrogen gas.

A second demolition charge is placed near the battery for the purpose of destroying the control equipment. This charge consists of a 2%-pound picric acid block fitted with a nonelectric blasting cap and a length of safety fuse. The safety fuse from both the picric acid and the flash bomb are connected to two blow-out plugs attached to the bottom of the center on the crosspiece of the aluminum ring. When these plugs are fired they ignite the safety fuse.

An aluminum ring, which constitutes the bottom portion of the apparatus suspended by the shrouds, is attached to 4 rods of the frame work. This ring contains 72 holes equally spaced on the periphery. Black powder charges are inserted in these holes. On the upper side of this ring are 2 contact wires about 4 inches long leading into the black powder charge. Leading out, of this charge and up to

the outer periphery of the upper contactor ring is a piece of safety fuse which initiates a black powder charge. The charge blows out a plug releasing a spring loaded contact arm completing the electric circuit to the next set of blow-out plugs on the ballast ring. However, the burning time of the safety fuse allows the now lighter balloon time to again rise to an altitude at which the baroswitch interrupts the circuit. Suspended from the aluminum ballast release ring may be found any or all of the following. Sandbags to serve as ballast. 5 kg. thermite incendiary bombs or Army 12 kg. incendiary bombs fused in the nose with an A-2 (a) fuze. (USNBDIB #81). If found with the 15 kg. type 92 anti-personnel H. E. bomb (USNBD Jap Bombs & Fuzes pg. 17) it will probably be carried under the crosspiece and held in place by the two blow out plugs which initiate the safety fuse to the picric acid charge.

The operation of the balloon and elevation control device is as follows. The balloon is filled with hydrogen gas at the launching point. It is probable that they are only filled to a fraction of their capacity as the decrease in barometric pressure when the balloon rises would cause an increase in pressure within the balloon

*The ballast release ring, showing method by which electric contact is made in the contactor ring by release of the contact arm. Only one contact arm remains in the unfired condition in this particular view.*

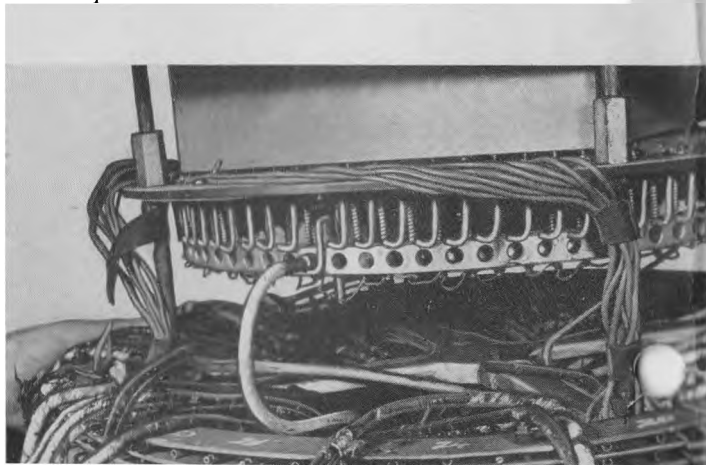

causing the valve to release some of the hydrogen. By controlling the amount of gas put in the balloon the optimum altitude can be obtained. Any rise above the predetermined altitude would cause the hydrogen to escape causing a reduction of lift.

The balloon is launched and rises to the predetermined height. Due to an unavoidable loss of the hydrogen gas through the walls of the envelope, the balloon slowly begins to descend, but only after a prolonged flight which according to observed balloons may be as much as a week.

As the balloon descends a mechanical device designed to control elevation in flight and itself controlled by two baroswitches begins to function. An increase in barometric pressure closes a circuit between a 2%-volt wet battery, enclosed in a plastic case, and fires two electric blasting caps in the ballast ring. The detonation of the electric caps drops a 6%-

- 
- A. 15 kg. Type 92 Anti-Personnel HE Bomb.
  - B. 5 kg. Thermite Incendiary.
  - C. 12 kg. Incendiary.

*Below is pictured the picric block used as a demolition charge on the ballast release device. On the right is the flash bomb which destroys the envelope after the total pay load has been dropped. In the upper part of the picture is one unit of the total of thirty-six blow-out plugs.*

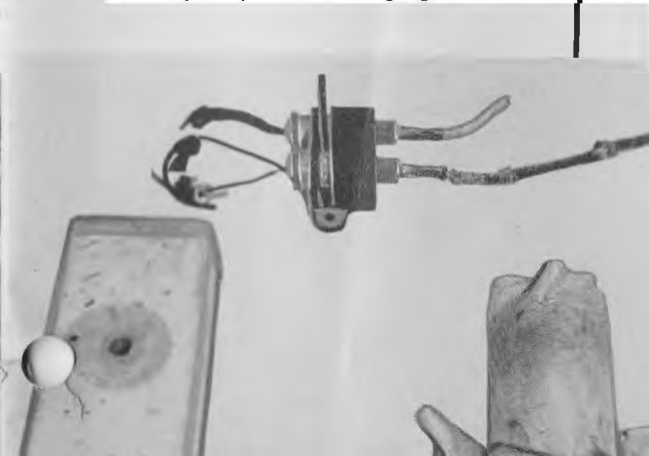

pound bag of sand and also lights two 18-inch lengths of safety fuse. These two safety fuses burn and blow two more caps that release a metal peg, thus establishing an electrical contact that appears to prevent the flow of current to other electric caps until the balloon has ascended to a point above which the baroswitch makes no contact. The apparatus is then ready to repeat the process and is equipped to so function for 36 times. Pencilled on these two baroswitches are the altitude figures at which the switches will function.

In addition to the two baroswitches referred to above, the apparatus has a third baroswitch with an altitude figure approximately one half that on the other two switches. This switch is wired in the same manner as the others, but the electric caps in this instance detach the eye attached to the bottom' and center of the ballast release thus forming the automatic release device for the 15

kg. A/P bomb suspended from that position. Due to the fact that this switch functions at a much higher barometric pressure, the 15 kg. bomb will be the last payload to be released. Simultaneous with the release of center device the safety fuses leading to the two demolition charges are ignited destroying the balloon just before reaching the ground or soon after.

There are several possible uses for the Japanese balloon. The following are considered as some of the possibilities as to the main purpose:

- (a) Indiscriminate aerial bombardment of the west coast by release of great numbers of such balloons.
- (b) For release of incendiaries on the west coast during the dry seasons of the year.
- (c) For the transportation of agents, saboteurs or commandos to this coast.
- (d) For obtaining preliminary meteorological information in preparation for lighter-than-air or heavier

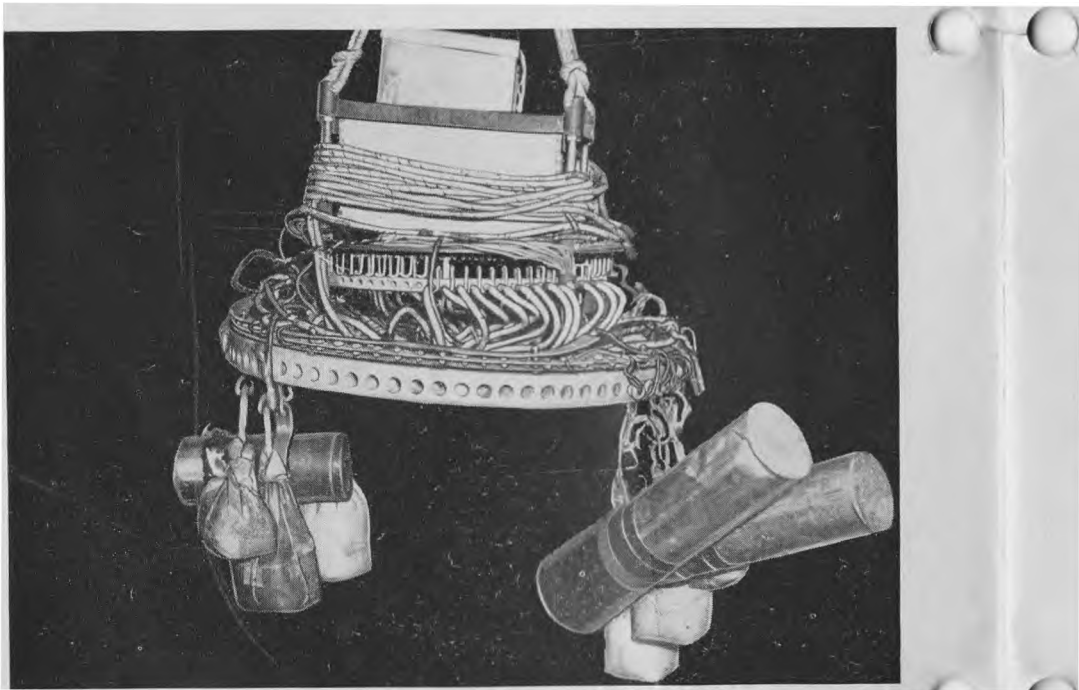

*The above view shows the method by which the ballast and payload are suspended from the automatic release device.*

than-air attacks against the United States.

The fact that the destination of such free balloons cannot be accurately predicted and the fact that to date bombs which have been dropped have been small, leads to the conclusion that the use of balloons even in large numbers would be to a large extent only a nuisance. Incendiaries could cause damage to our forests during the dry seasons but at such times of the year the air currents are not favorable for such a program. The possibility of carrying personnel is very slight as the altitude at which they must fly and the lapse of time would not make it feasible.

Tests made to date indicate that the balloon could stay aloft more than a week. It is thought that they are launched from the Kuriles or the main Japanese Islands. The most favorable altitude is 20,000 to 25,000 feet and January and February are the most favorable months of the year. Although it is possible that the balloons may be released from submarines the physical difficulties of such launchings do not seem to make such a procedure feasible.

The following report on recovery of one of the balloons gives some indication of the possible effectiveness and potential danger to uninformed personnel. This report was submitted by Lt. H. P. Scott, BDO. It is the first reported instance in which any casualties have resulted from the balloons.

"Upon arrival at the scene a Japanese balloon was found with various pieces of its equipment scattered around the nearby area. An explosion, evidently of the bomb carried by this balloon, had occurred and a woman and five children had been killed.

"It was necessary for the bomb disposal officer to render safe four incendiary bombs, a demolition charge, a flash bomb and various blow-out

plugs from the balloon under carriage before the bodies could be removed. This was accomplished, the bodies removed and the balloon and pieces were turned over to the proper authorities.

"From three nearby witnesses the following account of events leading up to the explosion was obtained: Mr. Blank was taking his wife and five children on a fishing trip. He had let them out of his car and was about to back it further down the road when Mrs. Blank called out, "See what we have found". Mr. Blank called out instructions not to touch anything and that he would come right there. He continued to back the car and within 2 minutes of Mrs. Blank's calling out there was an explosion. Mr. Blank found all six of the people dead when he arrived at the scene immediately afterward.

"The above information was obtained from Mr. Blank and two men working with a grader about 300 feet away.

"From the above information it is surmised that one of the party either dropped or kicked the bomb causing it to explode. Another possibility is that some new type booby trap or firing device has been incorporated into these balloons.

"An examination of the fragments from the explosion proved that the bomb was a Japanese Army 15 kg. antipersonnel H. E.

"The balloon had evidently been on the ground for some time as several of the parts were rusted, the paper mildewed and there were from 6 to 8 inches of snow beneath the paper. The surrounding area was entirely clear of snow.

"A cursory examination of the pieces recovered did not disclose any thing new in the construction of the balloon."

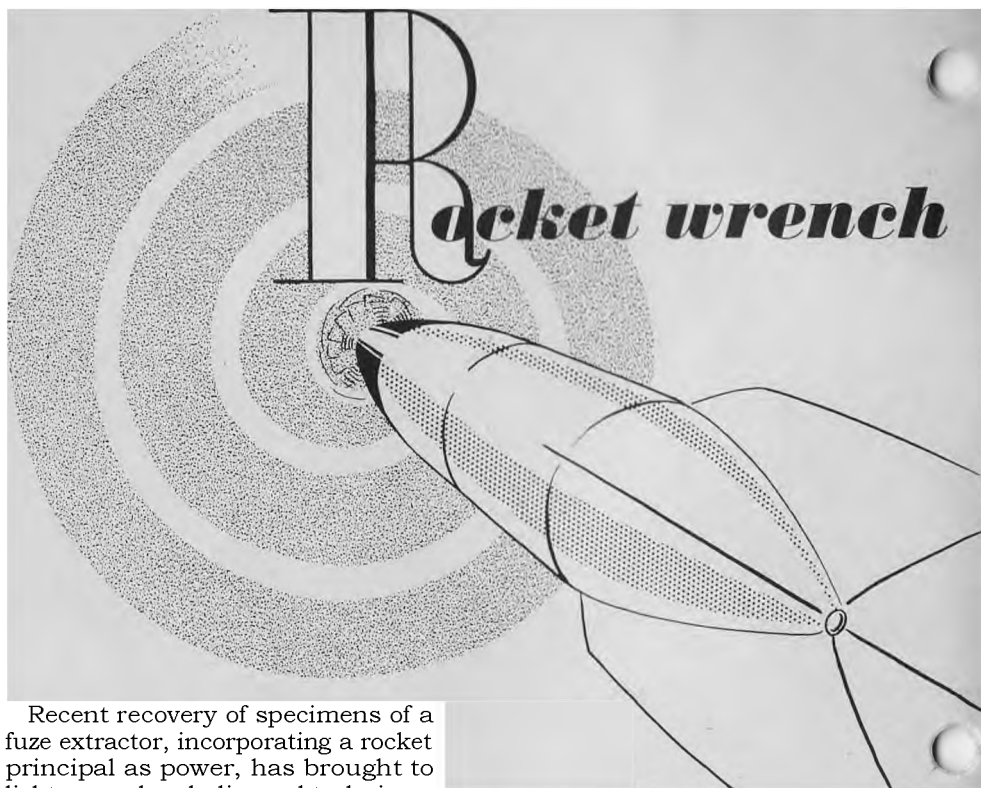

## Rocket wrench

Recent recovery of specimens of a fuze extractor, incorporating a rocket principal as power, has brought to light a new bomb disposal technique. This information has been substantiated by interrogation of German POW's.

Two models of the tool termed a "Rocket Wrench" have been recovered. One is of French and the other of German design. Both are presumed to have been designed to extract the British .37 Pistol. It is possible, however, that the wrench may be used on any fuze that will fit in the set screw chuck.

The German design, known as the M. T. (Marine Turbinegeraet) procedure, was invented and first applied by the German Navy. A charge of 200 grams of black powder is inserted into the head of a cylinder, which is then fixed onto the fuze. The black powder charge is ignited by a spark from a 300-volt sparking machine, operated from a distance of about 220 yards.

The Research Department USNBDS made six exact copies of the German

tool from blue prints received, and were used to run tests to study the potential value of such a tool. It was not possible to obtain pressed black powder pellets of a suitable size to duplicate the German propellant charge and as a result fine grained

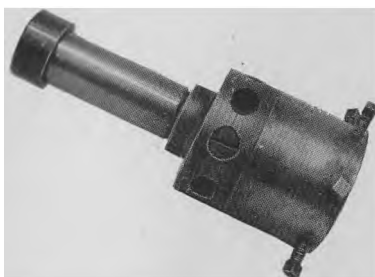

black powder was substituted. A one-fifth charge destroyed the tool. A one-tenth charge turned the fuze three-quarter turns. In an attempt to slow down the rate of burning, sawdust was added to the propellant

but the limits one-fifth to one-tenth charge could not be exceeded.

> The tool pictured above was designed by the Research Department USNBDS, and is similar to the German tool but was conceived to avert the difficulties encountered with the German design. The propellant chamber was designed to have a volume equivalent to the volume of the motor of the 2.36-inch rocket. Four nozzles were incorporated each having one-fourth the area of the nozzle of the 2.36-inch rocket. The same gripping attachment used in the German design was used.

The propellant from the 2.36-inch rocket was used and the wrench fired by the 2.36-inch rocket squib. The wrench was first used on a M100 fuze with the arming stem sleeve removed. The fuze remained in the bomb by two threads.

The MI03 fuze was turned down to fit the tool and screwed securely into the bomb. The wrench was fitted to the fuze, loaded and fired. In this test the fuze was completely removed from the bomb.

From the tests run the following disadvantages were perceived. The use of set screws to grip the fuze were unsatisfactory both from the point of not

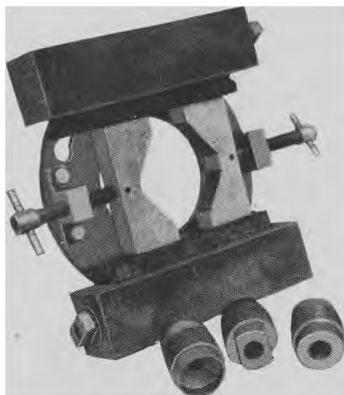

\ giving a positive grip and also that it was not sufficiently universal to fit most fuze. It was also found that the center of gravity of the tool was too far from the gripping point, the axial velocity of the tool was too great to be

safe for inertia action fuzes, and it was difficult to center the tool on the fuze.

In an attempt to correct the above defects tool (B) was produced. The tool had a jaw frame from an impact wrench to which were welded two barrels fitted with nozzles. The jaws gave a much more positive grip and could be adjusted to fit any fuze that would slide into the jaw assembly. The wrench was built to fire on a charge of .50 caliber propellant, therefore not requiring the special pressed black powder pellet. Tests run with tool however, showed the need for some system of hammer action to start fuzes that were fitted in the bomb more than hand tight. It was also found that simultaneous ignition of the two propellant charges was faulty in almost 70 percent of the tests run. To overcome this the wrench was modified to use only one propellant tube and counterbalancing it with a weight. The purpose of the counterbalance was two fold—it kept the plate in static balance and increased the weight



of the movable part (plate assembly) to equal that of the fixed part (motor).

Figure above shows the final tool as developed from the foregoing tests. To determine the optimum hammer stroke to be used on this model, a tool was built from the jaw assembly of a heavy impact wrench which gave a maximum hammer stroke of one complete revolution and a minimum of zero revolutions obtained by a single lug.

It was found from firing tests that a 60° stroke or one-sixth revolutions gave the optimum hammer stroke.

Two cylindrical barrels as can be noted in the figure are used but only one is fired for each fuze extraction. The two motors give balance, bring the plate up to proper weight and provide an extra nozzle as the nozzle becomes distorted when fired more than 20 times. These nozzles are threaded internally to screw onto the threaded portion of the barrel. The openings in the nozzle are nine thirty-seconds of an inch. The propellant charge consists of five one half grains of ballistite.

This tool has given complete satisfaction in removing British, Japanese, and United States fuzes, threaded very tightly, without causing the fuze to fire. It is designed primarily to remove and to fit most difficult fuzes. It will not remove an M123 or any other antiwith-drawal fuze before the fuze can fire.

These wrenches should reach the field by May 15th. The following rules on the care and use of the rocket wrench were prepared by the Research Department and should be closely followed.

*A—Propellant.*—The source of power for the rocket wrench is obtained from the motor of an Army 2.36-inch rocket. This motor contains 5 grains of ballistite about 4 $\frac{1}{6}$  inches long, a squib, and a grid all of which are used in the wrench.

If a supply of rockets is obtained they should be partially stripped for safety reasons only. That is, with the safety pin in place. (1) Thread off the explosive head from the motor tube with a Stillson, (2) thread out the booster by hand, (3) remove the detonator container with needle nose pliers, (4) pull the safety pin, and (5) shake out the striker. The ballistite should be left in the motor tube where it is sealed from the atmosphere until within a day or two of the time it is to be used.

To prepare the ballistite and squib for use, thread the tail fins off the motor tube, shake out the grains, and

remove the squib by pulling on the leads. For best results cut the grains accurately in half to form 10 grains 2 $\frac{1}{2}$  inches long. This can be done with cutting pliers, tin snips, or a hacksaw. Also a little loop twisted in the squib lead wires about  $\frac{3}{8}$  inch from the squib will better position the squib in relation to the grains. This loop goes between the grains and the grid and also serves to keep the squib from falling out of the barrel. A supply of extra squibs, if it can be obtained, will stretch the propellant twice as far.

The cut grains should be kept in a stoppered bottle or closed container until use. If ballistite is damp firing will be irregular and unburned grains may be blown out the nozzle. The wrench should still extract the average fuze, however.

*B—Wrench.*—The wrench is composed of two barrels about one-half the size of a standard rocket motor. These barrels are attached to a plate which is slotted to give a hammer action on the studs securing it to the jaw frame. The light jaw frame is slotted to allow movement of the hardened tool steel jaws. Set screws tighten the jaws on the fuze. 

To operate the wrench first load it in a horizontal position by placing three grains in the barrel, laying the squib on these and then inserting the remaining two grains. Push the grains and squib into position with the grid. The squib wires should pass through the center of the grid. Thread on the nozzle or barrel cap medium wrench tight with the squib wires coming out through the nozzle. Only one barrel is loaded as both barrels will not fire simultaneously and seem to be of no benefit. The second barrel provides wrench balance, an extra barrel, and an extra cap. A nozzle will probably burn out sufficiently in 20 shots to cause a marked decrease in power. Extra caps are provided to care for this as it would be much more expensive to use high alloy material and the increase in life did not merit it.

Next, place the wrench on the fuze

with the jaws next to the bomb. Tighten the jaws down so as to center the wrench on the fuze. Use about all the torque you can apply to a 10-inch crescent wrench for this, as tight jaws well located will prolong the life of the teeth. Loose jaws will machine a groove on the fuze and promote teeth breakage. Set the hammer action, connect the demolition cable to the squib; retire to a safe distance and fire. All standard checks with a galvanometer should be made.

After firing the wrench three or four times, check to make sure the studs holding on the plate are still tight. Hammer action may loosen them. Also clean out any metal that

may be filling the jaw teeth. After 15 or 20 shots use another nozzle. Keep the wrench as clean and well oiled as possible.

This wrench has repeatedly removed fuzes which have had the threads distorted and then tightened in a bomb with a 24-inch Stillson. The M100, M112, M103, C-2 (a), A-3 (b), A-4 (a) fuzes were used in these tests. The C-2 (a) had the locking ball in place. The M112 was tested with a live detonator and extraction was not sufficiently rapid to fire. The wrench *will not* remove an M123 before it can fire. Sufficient speed for this is not even approximated by this wrench.



*No, No, George, you let go of the Rocket wrench before you fire it!*

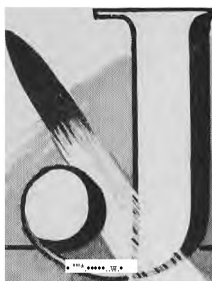

*apanese*

# **PROPELLANTS**

---

The following information on Japanese Navy propellants is published as an aid to Bomb Disposal personnel. The chemical analyses given below constitute the best information available at present, but are not to be considered conclusive in establishing the exact chemical identity of the code types with which they are listed. Since the various samples were not analyzed in direct comparison to each other by a single laboratory, certain critical differences between types may have been overlooked.

From a study of the data tabulated and of actual samples of recovered Japanese Navy propellants, the following deductions have been made:

1. The various standard service propellants used in Japanese Navy Ammunition are all double-base powders (i. e. Nitrocellulose-nitroglycerin mixtures). The developmental program is strongly influenced by the development and manufacture of British naval propellants. Nomenclature and even abbreviations appear to be based on British custom.

2. Rocket fuels are identical to,

or developed directly from, the standard propellants for Naval guns.

3. The propellants are known by type numbers derived from the year of adoption, but are commonly identified on labels by a short code designation consisting of combinations of English letters and Arabic numerals.

The short code designation is composed as follows:

(a) A basic letter (e. g. "C" or "T") identifies the form of the powder grain.

C-Cord form (solid cylindrical stick).

T-Tubular form (single perforated cylindrical stick).

The mention of both "Tubite" and "Cordite" in Japanese documents suggests the possibility that the Japanese refer to these forms of grain as "cordite" and "tubite" as distinct from one another, but all evidence indicates that code counterparts, e. g., DC<sub>2</sub> and DT<sub>2</sub>, have the same chemical composition though they vary in form of grain.



Code abbreviation			Complete designation	Recovered sample	
Word part	Tubular	Strip		Analysis	Identification
C...			Ordinary cordite.	N. C ..... 65.6 N. G ..... 29.2 Cent ..... 03.7 NaCl ..... 1.5	37 C. 14 cm. MEIU #1 R4)
C2 ...	T2 .....		Type 2 Yr. (1913).	N. C ..... 64.4 N. G ..... 30.3 Nerolin (m) 4.2	5 C2. Short 5 cm. N. P. F. Indian-head.
C3...	T3 .....		Type 89 (1929) ..	Volatile .... 1.1 N. C ..... 74.5 N. G ..... 26.1 Diph ..... 0.3 NaCl ..... 0.1	20 C3. 8 cm. Semi-fix. MEIU #1 R102.
C4...	T4 .....		Type 92 (1932) ..	N. C ..... 65.0 N. G ..... 39.0 Diph ..... 0.7	11.5 C4. 40 mm AA. MEIU #1 R.
DC...	DT .....	DB or DL.	Type 13 .....	N. C ..... 65.0 N. G ..... 30.9 Cent ..... 3.6 NaCl ..... 0.5	21 DC. 12.7 cm. MEIU #1 RIM.
DC 1.	DT 1....		Type 93 Mk 1 (1933).		
DC 2.	DT 2....	DB2 or DL 2.	Type 93 Mk 2 .	N. O ..... 65.0 N. G ..... 30.0 Cent ..... 3.0 NaCl ..... 2.0	240 D'1'2. 20 cm Rocket. MEIU #1 R106.
	Sp. DT 2 .....				
DC 3 .	Sp. DT 6 .		Type 3 (1943) ...	Analysis pending.	240 Sp. 45 CIT1106(1'1. MEW #1 R148.
MDC.	MDT....		"MD" Cordite ..	Presumed to be based on British "Nil" Cordite.	
F2....			Type 90 Mk 2 (Flashless?).		
FD			Type 2 Mk 1 Flashless.		
ID 1 .			Type 2 Mk 2 Flashless.		
	Sp. FDT 6 .			N. C ..... 59.9 N. G ..... 26.9 1 - Nitro-naphth . 6.1 Pot. Sulfate . 2.9 Eth. Cent .. 2.9 Volatile ..... 1.3	{500 Fl }   "Bake" Nitritt Unit. N. 1'. F. Indian-head.

NC.- Nitrocellulose  
tit'l Sodium Chloride

N. G.-Nitroglycerine  
M-Methyl

Cent.-Centralite  
Eth-Ethyl

Machine Gun Propellant Powders

(In British terminology the term "cordite" was derived from the cord form in which the original double-base powder was made. It has since come to mean any of the common double-base powders, regardless of form.)

Other abbreviations:

D—the meaning of this abbreviation has not been determined, but apparently represents a change sufficiently great to establish a new series.

MD—presumed to be the British designation "MD" or "modified cordite (obsolete)". (British MD cordite: Nitrocellulose, 65 percent; Nitroglycerine, 30 percent; Mineral jelly, 5 percent.)

F—Flashless powder.

K—Machine gun propellants (7.7 mm, 13 mm, 20 mm, 25 mm, etc.).

E—Blank.

(b) A numeral suffix, e. g., "2" in DT<sub>2</sub> indicates a specific chemical composition in a developmental series, e. g., "DC<sub>1</sub>" designates Type 93 Mk 1 and "DC<sub>2</sub>", Type 93 Mk 2. The derivation of this number is not regular. See chart above.

(c) The numeral prefix has nothing to do with chemical composition, but expresses the gage of the powder strand or more precisely, the gage of the die through which the strand is extruded. It apparently is expressed in tenths of millimeters. In the case of solid sticks, the gage is equal to the diameter of the stick in tenths of millimeters. Hence "20 C3" indicates a stick of C3 propellant (Type 89, unperforated), 2 millimeters in diameter.

However, in the case of tubular sticks, the gage is equal to the wall thickness of the tube expressed in tenths of millimeters.

The gage is an important characteristic of a propellant in that it measures the actual thickness through which the burning of the powder proceeds, and is comparable in this respect to the United States expression of "web thickness" of powder grains.

Since the sticks of propellant are

Code designations do not signify the form of the propellant. May be flake, perforated, and grains or

K1 .....	Type 89 Mk 1 Machine Gun Powder.
K 12 .....	Type 89 Mk 1 Machine Gun Powder (R).
K 21 .....	Type 95 Machine Gun Powder.
131 K 23 .....	Type 1 Mk 3 Machine Gun Powder.
K 31 .....	Type 1 Mk 1 Machine Gun Powder.
K32 .....	Type 1 Mk 2 Machine Gun Powder.
K 41 .....	Type 1 Mk 2 Machine Gun Powder (R).
K 42 .....	Type 1 Mk 2 Machine Gun Powder (R).

dried after extrusion and undergo some shrinkage due to the evaporation of the solvent, the actual dimensions of the finished sticks may vary slightly from the expressed gage.

The gage of the following recovered specimens of solid cylindrical sticks has been checked and found to cor-

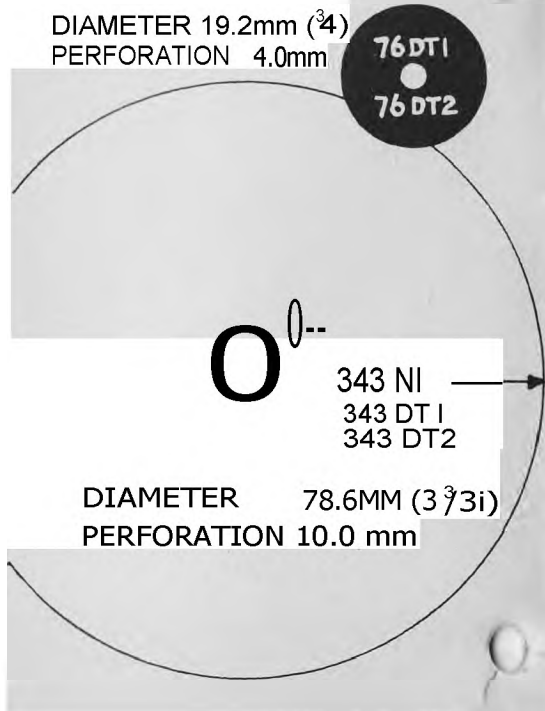

respond within the limits of variation caused by shrinkage:

- 5 C2—Gage 5-0.5 mm diameter of stick.
- 11.5 C4—Gage 11.5-1.15 mm diameter of stick.
- 20 C3—Gage .20-2.0 mm diameter of stick.
- 21 DC—Gage 21-2.1 mm diameter of stick.
- 30 DC—Gage 30-3.0 mm diameter of stick.
- 37 C—Gage 37-3.7 mm diameter of stick.

The dimensions and gage of tubular sticks known to date (rocket propellants) are outlined below. Dimensions are based on gage of dies and will vary slightly from the actual dimensions of the sticks.

Known Usage of Navy Propellants:  
 R—Identification thru recovery.  
 D—Documentary evidence.

- 37 C ..... 14 cm. gun (R).
- 5 C2 ..... Short 5 cm. gun (R).
- 20 C3 ..... 3 cm. low angle gun (semi-fixed) (R).  
                   8 cm. AA gun (fixed) (R?).
- 11.5 C4 ..... 40 mm. AA gun (R).
- 21 DC ..... 12.7 cm. AA gun (R).
- 30 DC ..... 12 cm. AA gun (R).  
                   12 cm. low angle gun (S. F.) (R?).
- 76 DT1 ..... Temp. Type 3 No. 1 Mk 28 (rocket) (D).
- 343 DT1.. Type 3 No. 25 Mk 4 rocket bomb (D).
- 76 DT2 ..... **Exper. 18 No. 6 Mk 27** (rocket bomb) (D).
- 240 DT2. . . 20 cm. Spin-stabilized rocket (R).

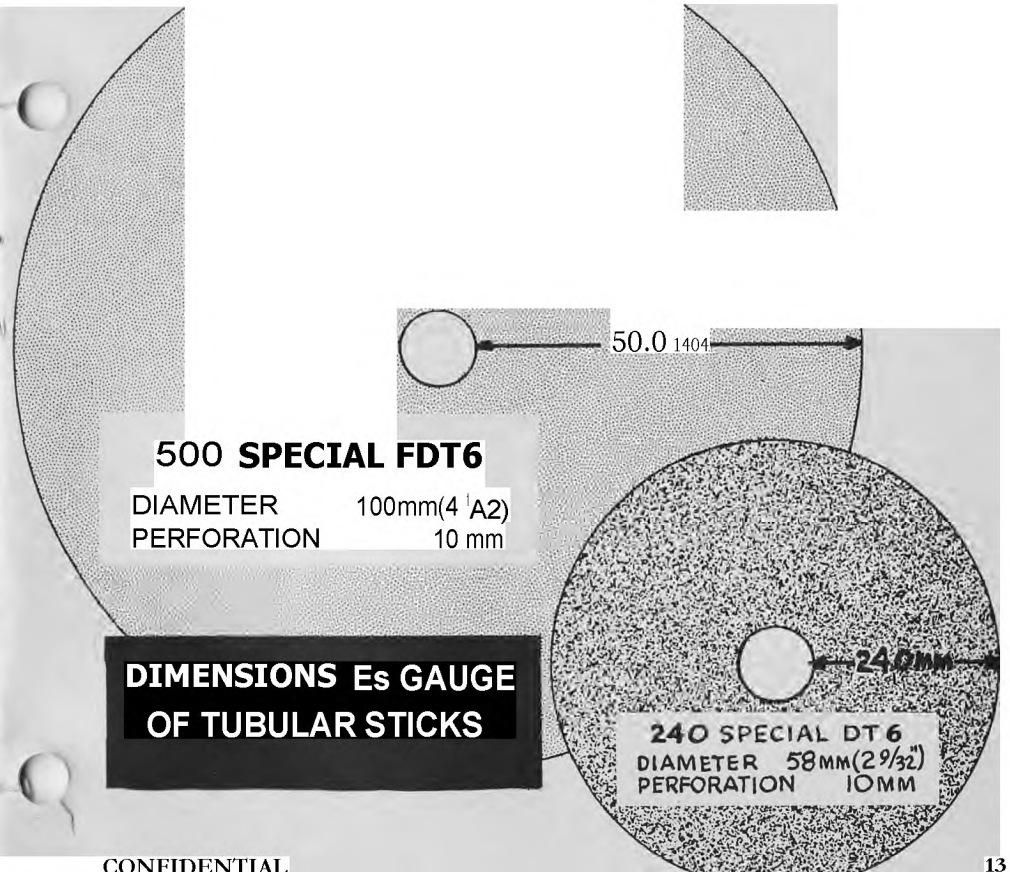

- 240 Special 20 cm. Spin-stabilized rocket DT2.  
 Type 93 Mk 2 Take-off assist rocket (D). (DT2).  
 343 Special Take-off assist, rocket model DT2.  
 Bomb launching rocket motors (D) (60 kg. and 250 kg.).  
 240 Special 45 cm. Spin-stabilized rocket DT6.  
 500 Special. Type 4 Mk 1 rocket motor FDT6. (D) (for "Baka" bomb).

In the case of the rocket motors for the "Baka" bomb and the motors for launching 60 kg. and 250 kg. bombs from the ground, the propellant has been recovered, but without identifying labels. In dimensions that could

be checked, the recovered sticks agree with the prescribed type mentioned in documents.

If the abbreviation "F" in short designations indicates a flashless powder, the propellant for the Baka bomb (500 Special FDT6) is of particular importance, since it is the first propellant of this type to be recovered.

Information acquired since the above material was first organized indicates that propellants of the "K" group (propellants for small arms and automatic weapons) are single base powders rather than double base as are those for larger caliber guns. A typical formula appears to be diphenyl lamine-stabilized nitrocellulose.



## JAPANESE BOMB ETIQUETTE

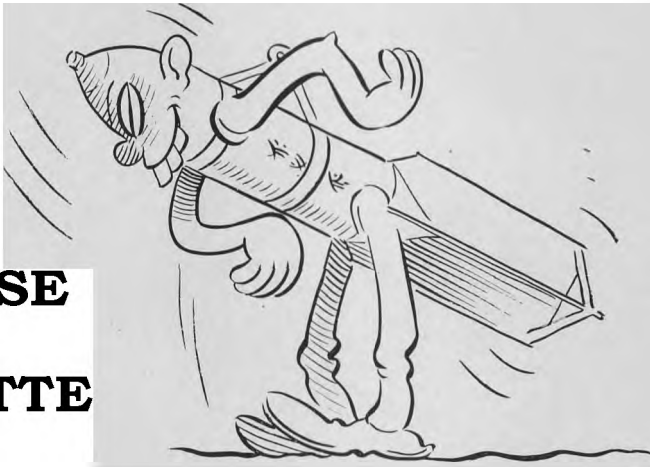

The following is an excerpt from a field report on the operation of the Japanese Army 12 kg. Incendiary.

"The second bomb was placed *virtually, nose down as it would be if dropped from a plane.* A similar set up was used to actuate the fuze. The following results were noted: the nose and body (in one piece) were driven 6 inches into the ground (loam and sand), the 3 incendiary units were **expelled into the air.** One unit went approximately 250 feet high and the other two approximately 75 feet high.

The greatest or highest unit did not burn out completely, only the **thermite core burning out.** The other two units burned for 9 and 103 minutes, *respectfully.* The tail cone was not recovered.

Ed. Note:

"Bowling and scraping in the usual Japanese manner, the 12 kg. retired."

No offense meant, but this was just too good to miss. This was the first information we have had on the operation of the 12 kg. incendiary. Good work.

# Japanese Chemical Fuze

An enemy publicatiog dated 1 August 1943 has revealed s e interesting data on the construct' and possible uses of a simple chemjcal fuze as an igniter for improvised land mines.

The fuze according to the document is assembled in the following manner. A glass ampoule containing sulfuric acid is placed in a small rubber sack containing a mixture of potassium chlorate and sugar. The formula by weight is two parts sulfuric acid, three parts potassium chlorate and four parts sugar.

The ampoule and rubber sack are placed directly over a nonelectric blasting cap or a small charge of black powder. Crushing the ampoule will cause the acid to act on the mixture of potassium chlorate and sugar. This chemical reaction produces fire which is transmitted to the black powder, which initiates the detonator.

To increase the possibility of a tank contacting the chemical fuze, a wooden or steel plate, with a small block affixed on its lower side, is placed over the fuze and held away from the fuze by a shear wire which passes thru the block and into the walls of an improvised well in the bottom of which is placed the ampoule and mixture of potassium chlorate and sugar. A weight of 0.7 kg. per square cm. will cut the shear wire and crush the ampoule.

According to the document the fuze has a delay of from 0.5 second to 1.0 second from the time the chemicals ignite until the charge is detonated. This makes it necessary to place the mines on which the fuze is to be used in congested areas in which the speedy maneuvering of tanks is impossible.

Two drawings of the complete improvised mine with fuze attached were included in the document. Both models used projectiles as the explosive charge. In discussing the mines the document suggested that projectiles especially captured ones be used

According to the document, the

main advantage of such a fuze lies in the fact that it is cheap to manufacture. It should also be noted that its use could be quite universal. Any explosive charge could be easily rigged to be fired by such a device as no special fittings are needed to adapt the fuze to any size fuze pocket.

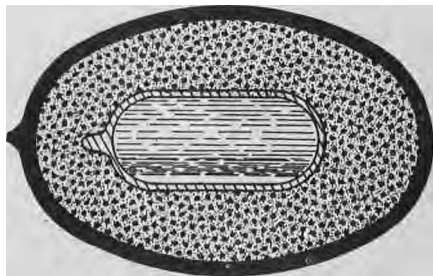

1. Gross sectional drawing showing acid ampoule enclosed in rubber sack containing potassium chlorate and sugar.



2. End view of fuze installed to detonate two field gun projectiles.

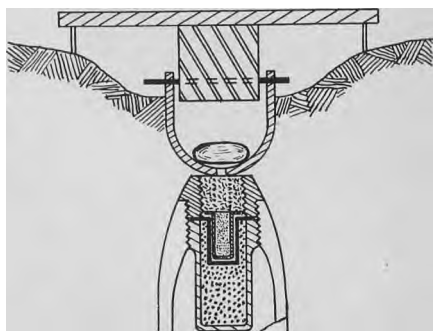

3. A 15 cm. howitzer fitted with a chemical fuze.



# IMPACT FEATURES

A mechanical impact feature has been incorporated in the U. S. T76E10, T100E10, T8 OE1 0 and T97-E10 VT projectile fuzes to give impact detonation of those units in which the VT action does not operate.

The fuzes which at present incorporate the new impact feature are used in howitzer work and may therefore be encountered by B. D. personnel. If recovered, the fuze must be considered to be in a dangerous condition and should be handled with care.

The unit is known as the Mk 10 rear fitting for VT Projectile fuzes and is installed in the fuze by removing the conventional detonator carrier and mercury switch unit and substituting the impact unit. The impact unit still retains the mercury switch and detonator carrier and in addition houses the impact feature.

Standard disposal procedure prior to the use of the impact unit was as follows: Wait a period of 15 minutes before approaching the fuze. When possible, blow in situ. Never remove the fuze from the projectile. If in A-1 or B-1 category and the plastic nose and firing condenser have not been destroyed by impact with earth, aim a Mk 2 shaped charge at the junction between the plastic and steel base ring and detonate remotely before moving. If, however, the plastic nose cap and firing condenser have been sheared of or badly damaged, it is assumed the battery circuit

will be shorted out and the fuze, therefore, safe to move.

With the installation of the impact unit, however, the fuze can never be assumed to be safe. Regardless of the condition of the plastic nose cap and firing condenser, the impact unit may still be functional. Prior to rotation two spring loaded detents and a small leaf spring position a movable detonator carrier in the impact unit, holding it away from the fixed striker located in the forward part of the unit. Rotation causes the detents to move out freeing the movable detonator. On impact (if VT action fails) inertia causes the detonator carrier to move forward overcoming the leaf spring. If the impact unit fails to function, the fuze is in a very sensitive condition. The leaf spring, having once been pulled away from a slotted groove in the base of the impact unit, no longer exerts a restraining force on the detonator carrier. The spring loaded detents are held out by the body of the detonator carrier, thus leaving the detonator free to impinge on the striker if jolted.

All VT fuzes recovered regardless of condition should be carefully inspected before moving. If the fuze cannot be positively identified and it is impossible to blow the projectile in situ, care should be exercised in removal. If the fuze is held in a horizontal position or with the nose slightly higher than the base, danger of the detonator coming in contact with the fixed striker is decreased.

# MK 10 REAR FITTING FOR VT PROJECTILE FUZES

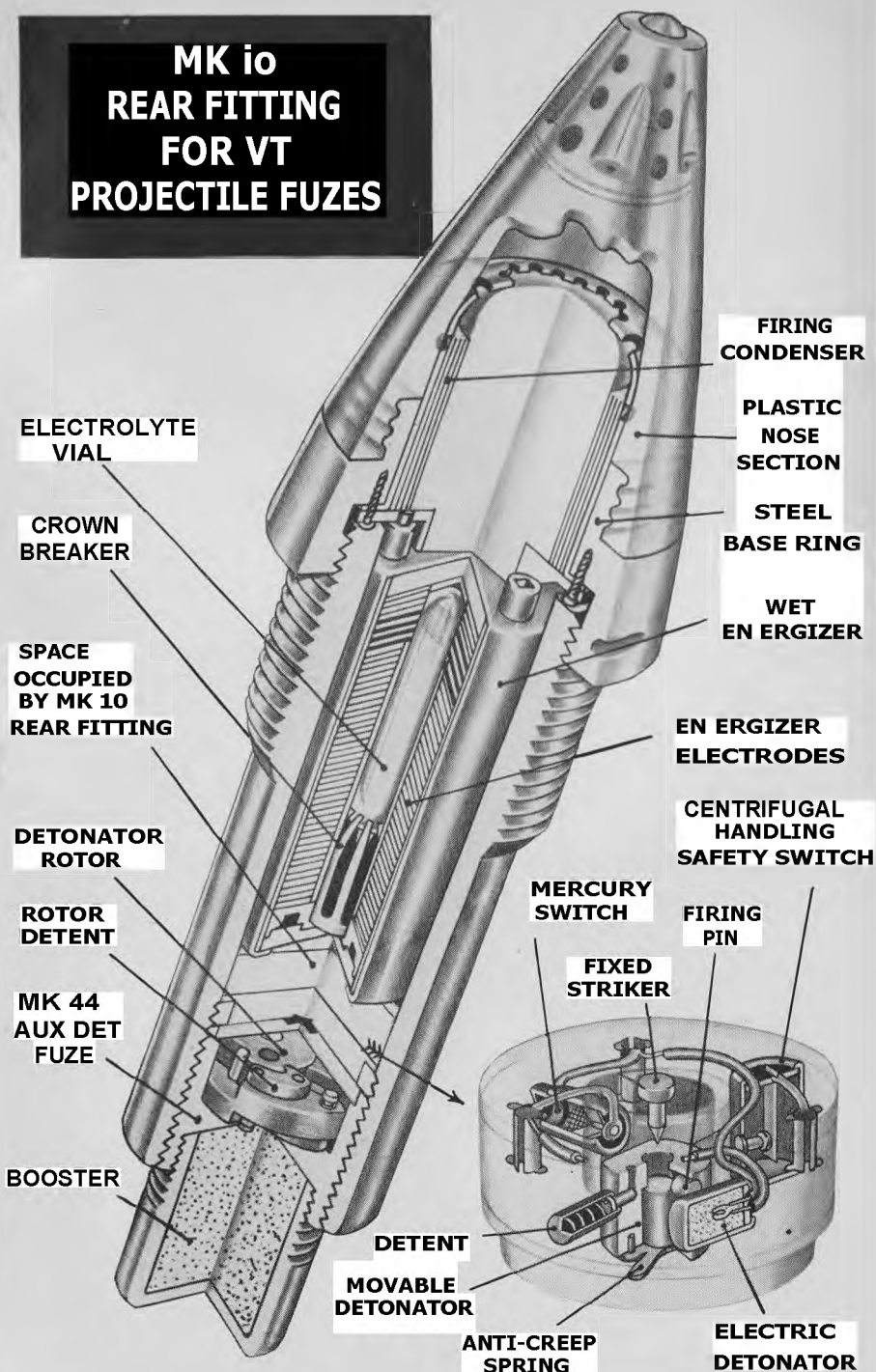

**PHANTOM VIEW OF  
MK 10 REAR FITTING**



# Russian Bombs

With the exception of a few isolated specimens, very little information has been obtained on Russian bombs to date. Perhaps the most complete document on this subject, is a German pamphlet recently captured in the Italian theater. Wherever possible, this information has been checked against known specimens, and it is believed that the data contained in the document is a reasonably accurate, but by no means complete, discussion of Russian bombs.

Russian bombs may be broken down into eight main classes: H. E., armor-piercing, fragmentation, rocket, incendiary, rotating spraying, flares and

propaganda. In addition to these, there is a subordinate class consisting of incendiary devices, such as phosphorous balls.

## HIGH EXPLOSIVE BOMBS

**FAB** (fugasnaja aviabomba). Included in this class are the FAB 50 kg., 100 kg., 250 kg., 500 kg., and 1,000 kg. bombs. These bombs are of very crude three-piece construction, with the nose and the tail cone welded to the body. The tail fins, four in number, are welded to the tail cone, and are braced either by bar-type struts or a

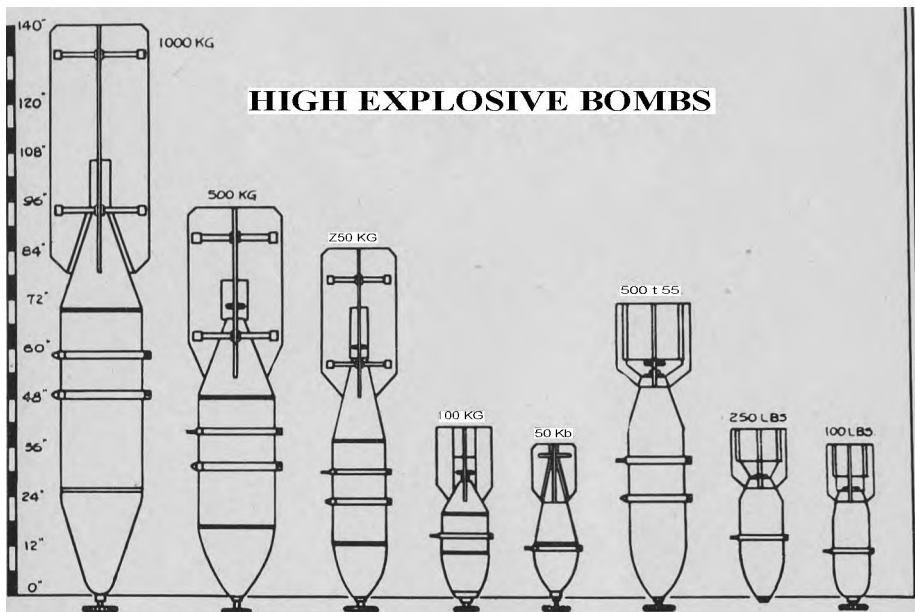

central ringed strut. They have a loading factor ranging from 45 to 50 percent of their total weight, and the main charge is mostly Trotyl (TNT). The 50 kg. and 100 kg. bombs are fuzed in the nose only with simple impact fuzes. The larger bombs have both nose and tail fuzes. In addition to the above bombs, the German document listed three "forged" bombs which are obviously United States 100-, 250-, and 500-pound G. P. H. E. bombs.

**ARMOR PIERCING BOMBS**  
**BRAB** (bronz e-boj naj a aviabomba). There are three sizes of armor piercing bombs, the BRAB 220 kg., 500 kg., 1,000 kg. These bombs are made from high-grade steel and are of two-piece construction, consisting of the bomb body and the tail cone. The tail cone is attached to the body by means of screws. According to the German document, the BRAB-220 is manufactured

50 Kg. FAB H. E.  
Bomb.



100 Kg. FAB H. E.  
Bomb.

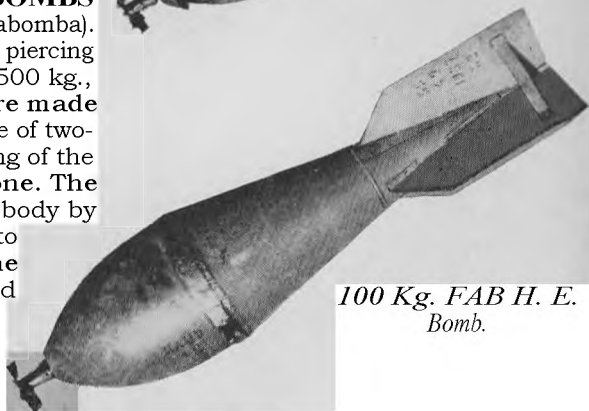

from a Russian Navy armor-piercing projectile and states further, that, according to Soviet evidence, the armor piercing bombs do not fulfill the latest requirements. Four fins are welded to the tail cone and are braced by bar-type struts. These bombs are fuzed in the tail only, and have a loading factor which varies from 16 to 25 percent.

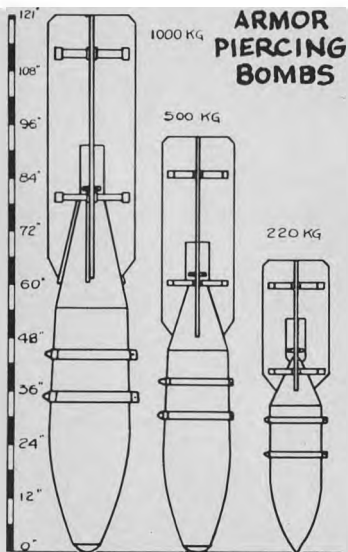

**FRAGMENTATION BOMBS**  
**AO** (oskolotschnaja aviabomba). This class consists of the following: AO-2.5 kg., AO-M<sub>4</sub> kg., AO-8M<sub>6</sub> kg., AO-10 kg., AOCh-15 kg., AO-20M<sub>1</sub> kg., AO-20M<sub>2</sub> kg., AO-20M<sub>3</sub> kg., AO-25M<sub>1</sub> kg., AO-25M<sub>2</sub> kg., FAG-50M<sub>2</sub> kg., FAB-50M<sub>3</sub> kg., FAB-50M<sub>4</sub> kg., FAB-50M<sub>5</sub> kg., FAB-50M<sub>6</sub> kg., FAB-50M<sub>7</sub> kg. According to the Germans, about 20 types of Fragmentation bombs, ranging in size from 2.5 kg., to 50 kg., have been established. A large percentage of this number are crude artillery projectiles. Only 4 of the frag-

mentation bombs are of the same type. These are the 2.5-, 10-, 15-, and 20-kg. bombs. They are made of cast steel and are of 2 or 3 piece welded construction. Their filling comprises diametrically about 10 percent of the total weight. Either point detonating or aerial burst fuzes may be used in these bombs.

**ROCKET BOMB TRS** (rakentnyj snarjad). Other than the RS-82, of which a poor photograph is available, very little is known of this class. The RS-82 is fired from a launcher, similar to our rail type launchers, mounted on the wing of a plane. Also included in this group are the RS-132, the BRAB-200DS (bronjebojnaja aviabomba S dopolnitelnoz skorostju), and the BETAB-150DS (betonobojnaja aviabomba S dopolnitelnoz skorostju).

**INCENDIARY BOMBS ZAB** (saschigatel'naja aviabomba). Two thermite incendiary bombs and two bombs with naphthal incendiary mixtures are used. In addition, there is a thermite incendiary fuze, whose weight comprises about 30 to 50 percent of the total weight of the bomb. The four bombs have been designated the ZAB-1-E, ZAB-2.5, ZAB-10 TG, and the ZAB-50 TG. They are crudely constructed and consist of three sections which are either welded or riveted together. Simple inertia type impact fuzes are always used with this



12.5 cm Fragmentation Bombs.



10.5 cm Fragmentation Bomb.



7.5 cm Fragmentation Bomb.

7.5 cm Fragmentation Bomb.



type of bomb. A colored band, believed to indicate the incendiary filling, is painted around the central section of the bomb.

**Rotation spraying bombs RRAB** (rotativno-rasseivajuschschaja aviabomba). Three sizes are known—the RRAB-1 (250 kg.), the RRAB-2 (500 kg.), and the RRAB-3 (1,000 kg.) containers. These bombs are con-

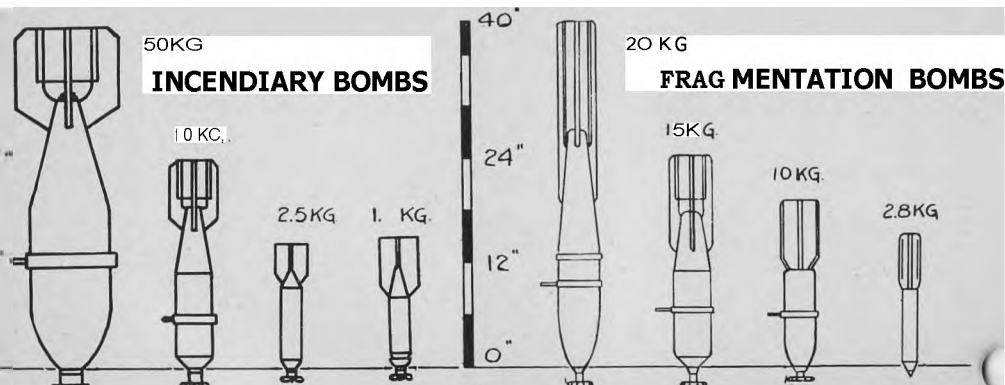

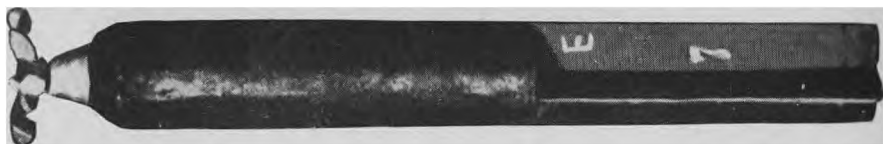

*2.8 Kg. Fragmentation Bomb.*

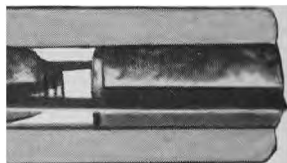

*15 Kg. Fragmentation Bomb.*

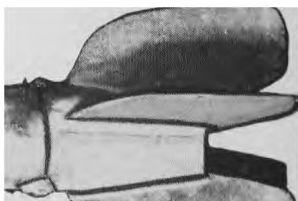
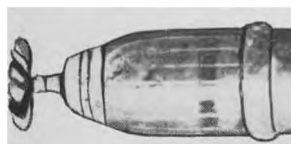

*R. S. 82 Rocket Bomb.*

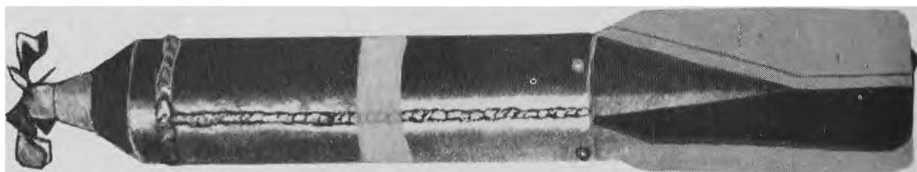

*2.5 Kg. Incendiary Bomb.*

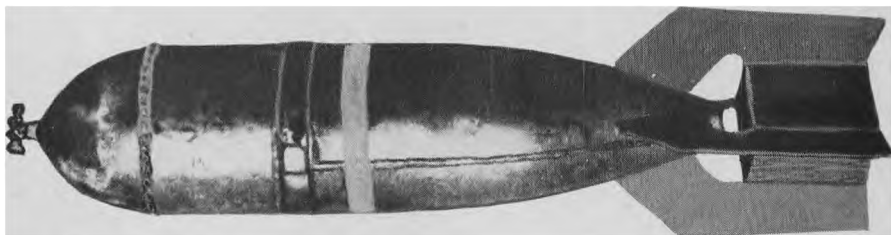

*50 Kg. Incendiary Bomb.*

tainers for fragmentation, poison gas, and incendiary bombs ranging up to 25 kg. in size and are also used for the dispersal of propaganda material. The containers consist of sheet-iron sides held together with baling wire

and clips. In addition, they have a large tail cone with three canted vanes which impart rotation to the container after it is dropped, and from which their name is derived. Each vane is braced by three bar type struts.

Aerial burst fuzes are used and at a predetermined height the container is opened and the bombs thrown out by a combination of centrifugal force and gravity.

**Flare bombs SAB** (swetjaschtschaja aviabomba). These are designated as the SAB-3, SAB-3M, SAB-15, SAB-25. It is assumed that the numbers refer to the respective weights of the flares, in kilograms; however, other than a photograph of the SAB-15 flare bomb, nothing is known of their construction or operation. They are believed to be typical flares.

**Propaganda bombs AB** (agitazionnaja aviabomba). The propaganda bomb is designed to drop leaflets from great heights. It consists of a wooden container which holds approximately 33 pounds of leaflets amounting to about 10,000 pieces. The leaflets are packed in cylindrical packages, which are scattered at predetermined heights by means of an aerial burst fuze.

**Incendiary devices.—The** Russians have three known types of incendiary devices. One of these is the incendiary ball. This is a globe filled with incendiary fluid. It is released from a container at a great height and breaks up on impact, the fluid igniting on contacting the air.

The second of these devices is a bottle, filled with an incendiary liquid, which is released from planes or hurled against armored vehicles in land fighting.

Another of these devices is the phosphorous globe-shaped container. These are released at a low altitude (about 500 feet).

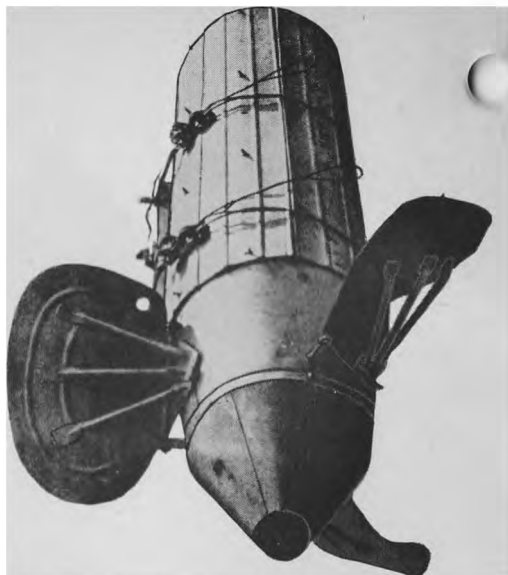

*Rotation Spraying Bomb.*

**Markings.—For** the most part, bombs are unmarked. However, a label may usually be found on the body and on the tail. The label on the bomb body contains the following information: caliber (?), fuzing, filling (i. e. TNT—Trinitrotoluol), detonator assembly ("detonator rlosheny") (only in case of 250 kg. and larger bombs), year of delivery (i. e. 1943), serial number (i. e. 101/82), and the number of the munitions factory (i. e. Zavod 97—Work 97). Markings are accomplished by means of letters and numbers. Any additional numbers usually indicate the weight of the filled bomb.



*Flare Bomb.*

**Color markings.—Russian** bombs the individual type of bomb. These are usually colored gray overall with bands may or may not be present. additional colored bands to indicate

Type	Tail	Nose	Middle
High explosive .....	.....	.....	
Ground (?) .....	.....	Yellow-red	
Fragmentation .....	Green .....	Blue .....	
Poison gas:			
Land poison gas .....	Red .....	.....	Green.
Gas chemical .....	Green .....	.....	Green.
Poison gas frag .....	Yellow .....	Yellow-blue	
Lethal gas smoke .....	.....	.....	Yellow-green.
Incendiary (electronic) .....	Yellow .....	.....	Blue.
Flares .....	White .....	.....	White.
Rocket .....	.....	Blue .....	Black.
Dummy .....	Red .....	.....	White.

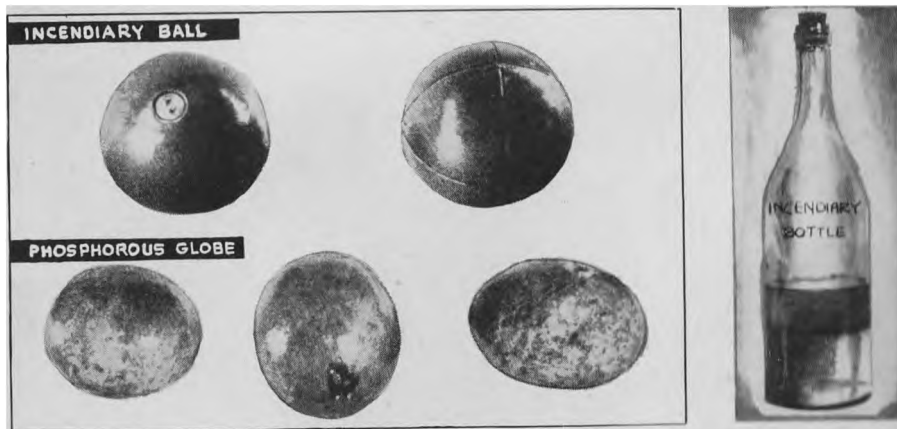

# NEW TYPE BARRAGE MORTARS REPORTED

According to a captured document, recovered in the China theater, the Japanese are equipping some of their surface vessels with three types of anti-aircraft weapons operating on the mortar principle. A Japanese crew member captured on Pingtan Island states that Type 1 is supposed to explode at 4,000 meters, Type 2 at 5,000 meters, and Type 3 at 4,000 meters. The prisoner admitted doubt of the claimed effectiveness.

A demonstration of the three types of anti-aircraft weapons was observed by the POW with the following results:

The Type 1, which is a light papier mache ball 15 centimeters in diameter, is placed in the bottom of a rough iron tube 4 feet high. It is ignited by lighting an almost instantaneous cord fuze retained near the mouth of the tube. The interval between the propulsion explosion and the explosion in the air is 3 seconds, at a height difficult to estimate but approximately 1,000 meters. After a few seconds two cotton parachutes opened out, their diameter 2 feet, each carrying an explosive charge about the size of a flashlight battery. Their characteristics are unknown but they did not explode on contact with the ground or after hurling. In one instance the fuze failed to ignite the projectile. In another, the parachutes were destroyed in the explosion.

Type 2 is a metal cylinder about 8 cm. long including a wooden handle. After removing the adhesive-taped safety device, it is fired as a mortar is fired. After the initial propulsion explosion the projectile disappeared from view, and after an interval of over one minute a powerful explosion occurred at the height of approximately 1,000 meters. Black smoke appeared and then a parachute was observed in two rounds of fire.

Type 3 is a rocket-type projectile. It is a metal cast explosive with a charge 25 cm. long, 7 cm. in diameter and attached to the end is a heavy metal rod, the same length, with tight metal tail fins. The Japanese name is "High Flying Type 3 Barrage Bomb," and it is fired as a mortar is fired. There is an aerial explosion after about 12 seconds at an unascertainable height. After 17 seconds an artificial silk parachute, carrying an explosive charge, was seen. Below the explosive charge is a piece of rope 15 feet long, at the end of which is a small burning substance which weaves the rope from side to side, but does not affect the downward course of the chute. The weaving motion continues from the height of about 2,000 meters to within 300 meters of the ground. The possible purpose of this weaving device is to entangle the rope in a propeller, thus drawing the explosive into the path of the blades.

The following comment comes from informed United States sources in China: The information agrees with previous reports from several sources and is the most detailed so far in the description of the method of propulsion. The Japanese have been experimenting with similar devices for some time. So far we have no known losses from them. They are dangerous to persons and have probably caused accidents in handling after reaching the ground. The idea is that a plane will catch either the cords from the chute to the explosive or a cord underneath, in either case giving a sharp pull on the cords and operating a friction igniter.

# NOMENCLATURE

) The memorandum printed below gives the standard nomenclature to be used when referring to the listed pieces of U. S. Ordnance.

---

## NAVY DEPARTMENT BUREAU OF ORDNANCE

WASHINGTON 25, D. C.

### MEMORANDUM

3 May 1945

From: Re7b

To: Officer in Charge  
U. S. Navy Bomb Disposal School  
American University  
Massachusetts and Nebraska Avenues NW.  
Washington 16, D. C.

Subj: Nomenclature.

1. For purposes of standardization, coordination with Bureau of Ordnance drawings, and general clarity it is requested that the following designations be employed hereafter to the exclusion of the varied nomenclature now current:

- (a) For the former 1" salute Mk 1 or "cherry bomb" used for booby trap training. Firecracker Mk 1, Mod 0.
- (b) For the former "Practice Bomb" or fuzeless firecracker designed by the Production Management Corporation at the request of the USNBDS: Firecracker Mk 2, Mod 0.
- (c) For the "Bazooka Cone" or "shaped charge Mk 1": Cavity Charge Container Mk 1, Mod 0.
- (d) For the "1 inch cone" or "2 oz. shaped charge": Cavity Charge Container Mk 2, Mod 0.
- (e) For the "3 inch cone" or "shaped charge Mk 3": Cavity Charge Container Mk 3, Mod 0.
- (f) For the "Linear Charge Liner (5"/38 cal. H. C.)": Cavity Charge Container Mk4, Mod 0.
- (g) For the "Linear Charge Liner (6"/47 cal. H. C.)": Cavity Charge Container Mk 5, Mod 0.
- (h) For the "Linear Charge Liner (8"/55 cal. H. C.)": Cavity Charge Container Mk 6, Mod 0.

2. It is further requested that the foregoing be published to all Bomb Disposal els.

(s) Lt. D. 1111,1,,

---

## GOAT VS MARINES

A certain MEIU was called upon to perform an experiment recently, involving the use of goats as a substitute for NI at Mrs. I. The ability of the goats to survive in the midst of burning gasoline was to be a measure of the potential fitness of Malloy% in a like situation.

The experiment was performed and results noted, I hr in 10% HMT thru with flying colors. Only a few singed hairs distinguished from a normal healthy goat.

The information obtained from the demonstration was et impiety and suitable to the end in view. It was considered a needless wov of personnel to repeat the demonstration substituting **Marines for** goats. The goats had landed and had the situation well in hand,



# JAPANESE

# Navy Projectile Fuzes

.. 40 mm AND OVER

The following is to be used as a quick reference for identification of Japanese Navy projectile fuzes 40 mm. and over. The delay settings, method

of arming, modifications and projectiles in which the fuzes are used are also listed.

## SPECIAL NOSE FUZE

## POWDER TIME FUZES



*a—Type 1 Special  
Nose Fuze*

*b—Type 3  
81 mm Mortar*



*c—40 mm A. A.  
Powder Time Fuze*



*d—Army Type 89  
Powder Time Fuze*

*a*—*Fraction* of second delay. Used in 8 cm. special common projectile for light penetration. Armed by rotation only, progressive arming system (interlocked pawls).

*b*—*Graduated* 5 to 20. Impact feature incorporated. Used in Navy Type 3 81 mm. Mortar.

*c*—*Graduated* 0-10. No impact feature. Incorporates gear wheel for automatic fuze setter. Used in 40 mm. A. A. only.

*d*—*Graduated* 0-30. No impact feature. Used in 8 cm. A. A. only.

## MECHANICAL TIME FUZES



*e—Type 91  
Mechanical Time Fuze*

*f—Type 91 Mech. Time Fuze  
Automatically Set*

*e*—Graduated 0-55. No impact feature. Spring driven clock. Prototype of three following fuzes. Used in 14 cm. for limited A. A., in 12 cm. A. A. guns, and in illuminating projectiles.

*f*—Graduated 0-55. No impact feature. Developed from Type 91 by addition of gear ring for automatic fuze setter. Used in 12.7 A. A. guns.



*g—Type 0  
Mechanical Time Fuze*

*h—Type 98  
Mechanical Time Fuze*

*g*—Graduated 0-55. No impact feature. Developed from Type 91 by reduced weight of setback spring and addition of flash shutter in basal portion. Marked by red nose. Used for A. A. in Short 12 cm. and Short 20 cm. Guns.

*h*—Graduated 0-45. No impact feature. Developed from Type 91. Incorporates automatic gear setting and flash shutter in basal portion. Used in Type 98 8 cm. (unrecovered) and Type 98 10 cm. A. A. Guns.

## POINT DETONATING FUZES

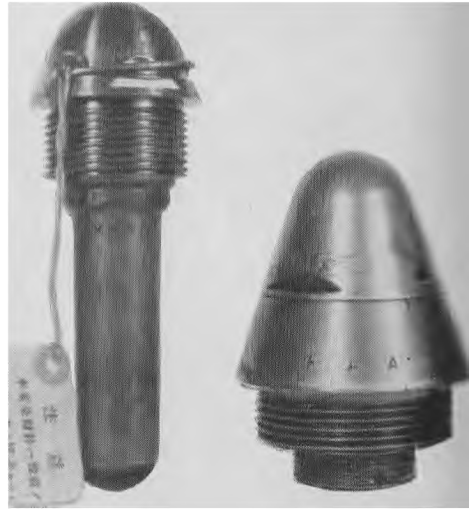

*i—Type 5 Yr.  
Point Detonating Fuze*

*j—Type 88  
Point Detonating Fuze*

*i*—Instantaneous. Armed by setback, rotation not required. Recovered in 8 cm., 12 cm., and 14 cm. projectiles for use against surface targets.

*j*—Instantaneous. Armed by setback and rotation by progressive arming system (interlocked pawls). A later variation, Type 88 Model 2 is also known. Interchangeable with mechanical A. A. fuzes for use against surface targets.



k.—20 cm  
Rocket P. D. F.

l.—Inst.  
5 sec. Nose Fuze

k—Instantaneous. Armed by rotation. Progressive arming system as in Type 88, but no setback required. Used in 20 cm. Spin-stabilized rocket.

l—Choice of instantaneous or 5 sec. delay, arms in the same manner as the rocket fuze. Used for surface and antisubmarine fire in Short 12 cm, and Short 20 cm. guns.

## BASE FUZES



m.—40 mm A. P. Base Fuze  
n.—5 cm Hotchkiss Base Fuze

o.—Type 3 rr. Mk 1 Base Fuze

p.—Type 13 Mk 1 Base Fuze

q.—Type 13 Mk (?) Base Fuze

m—Fraction of second delay. Armed by set-back, rotation not required. Used in 40 mm. A. P. projectile.

n—Nondelay. Armed by set-back, rotation not required. No detonating action. Use limited to projectiles with black powder filling. Short 5 cm. gun.

a—Fraction of second delay. Armed by set-back and rotation, eccentric weight

threads clown striker spindle to arm. Used in 12 cm. Common projectile.

p—Fraction of second delay. Armed by set-back and rotation, progressive arming system. Used in 14 cm. and 15 cm. Common projectiles and similar types.

q—Fraction of second delay. Operation identical to Type 13 Mk 1. Fuze is larger and heavier. Used in heavy caliber (e. g. cm.-14 inch) armor piercing projectiles.

