

**BRITISH
LAND MINES
AND
FIRING DEVICES**



I FEBRUARY 1945

SECTION I

BRITISH ANTI-TANK MINES & FUZES

A/TK. MINE G.S. MK. II

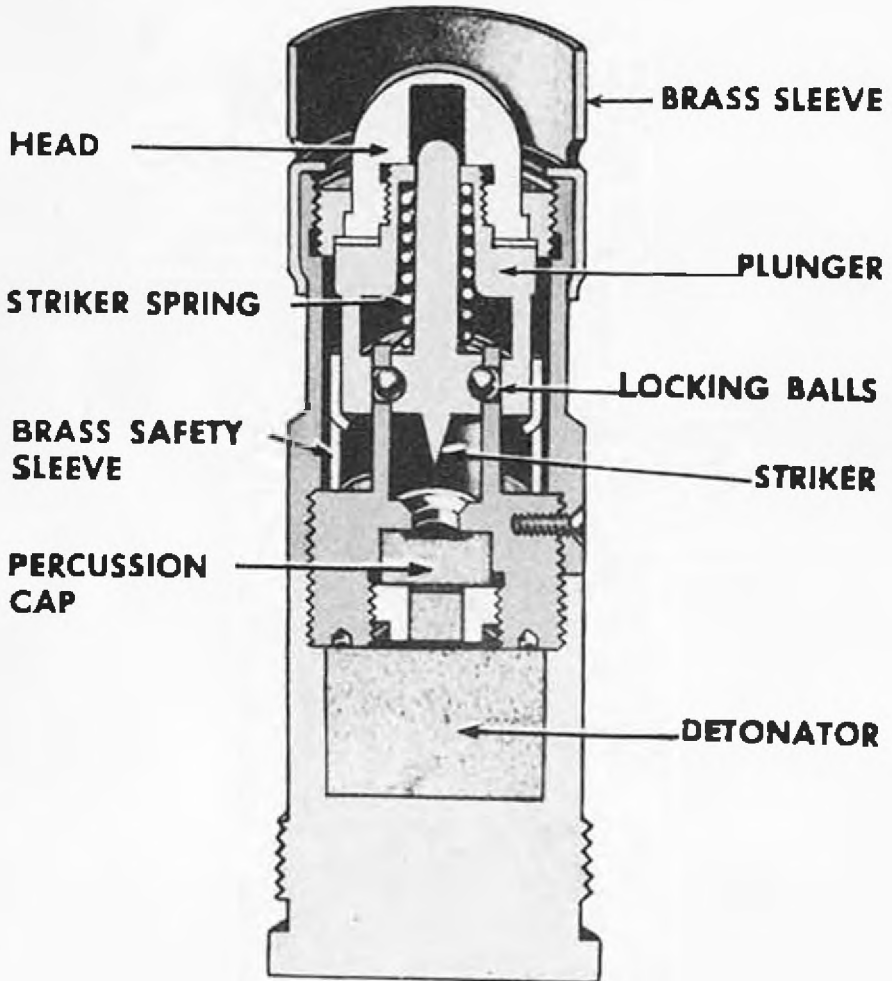
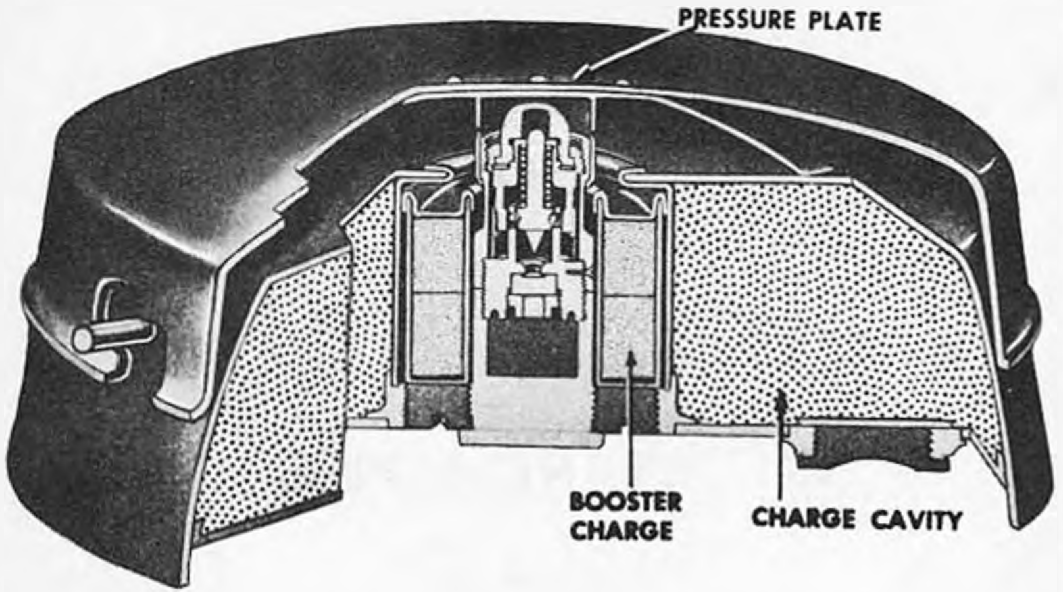

DIAMETER 7-1/2 in.
 HEIGHT 3-1/4 in.
 TOTAL WEIGHT 9-1/2 lbs.
 EXPLOSIVE WEIGHT 4 lbs.
 EXPLOSIVE T.N.T. or Baratol
 MATERIAL Steel
 COLOR Sides and top dark green;
 bottom yellow, with cross
 of red and green.
 FUZE Mine, contact, A/T, No. 1
 Mk II.
 PRESSURE RESQIRKD. Approximately 350 lbs.

BRITISH MINE**G. S. MK. II**

(ANTI-TANK)

(OBSOLETE)

USE: Defense against armored cars, tanks, or other vehicles. The mine will break tracks of light and medium tanks and disable other vehicles.

COMPONENTS: The G.S. Mk II Mine has three main components: loaded body, cover, and fuze. The mine cover fits over the body and is kept clear of it by a leaf spring. Pins on the sides of the mine body engage bayonet sockets in the cover. The cover of this mine must never be removed after the mine is armed. Words to that effect are stamped on the cover of the mine.

(a) Mine Body: The mine body is cylindrical in shape. Passing through the center of the mine is a cavity for the insertion of the mine fuze. During ordinary shipping and storage, this cavity is closed by a shipping plug. A booster charge in a ring-shaped container is placed around this central cavity. The remainder of the mine is filled with the explosive main charge. The mine is fired when the weight of a vehicle overcomes the leaf spring under the cover and allows the cover to force down the top of the fuze.

(b) Fuze, Mine, Contact, A/T, No. 1 Mk II: This fuze operates on the ball-release principle and consists of a cylindrical body containing a striker mechanism, a brass safety sleeve, a percussion cap, and a detonator. Over the top end of this fuze is crimped a thin-walled brass sleeve. Four prongs on a brass safety sleeve retain a plunger in which are located a striker and striker spring. The striker is retained by two locking balls which are held engaged in a groove in the striker by the plunger. To the top of the plunger is fitted a pressure head. Pressure on the cover of the mine crushes the thin-walled brass sleeve and forces the pressure head and plunger downward. The four prongs on the brass safety sleeve release their grip, and the striker spring is compressed. The locking balls are forced outward into a recess in the plunger, and the striker fires the percussion cap which explodes the detonator.

ASSEMBLY & ARMING: Place mine on its edge and unscrew the shipping plug from the center of the bottom of the mine body. Remove fuze from its cardboard container and screw into the mine finger-tight. Place mine in its hole cover side up.

NEUTRALIZATION: To neutralize the mine, reverse the arming procedure outlined above.

REMARKS: 1. If mine is to be re-used, inspect the fuze to see that the thin-walled brass sleeve has not been crushed.

A/TK. MINE G.S. MK III

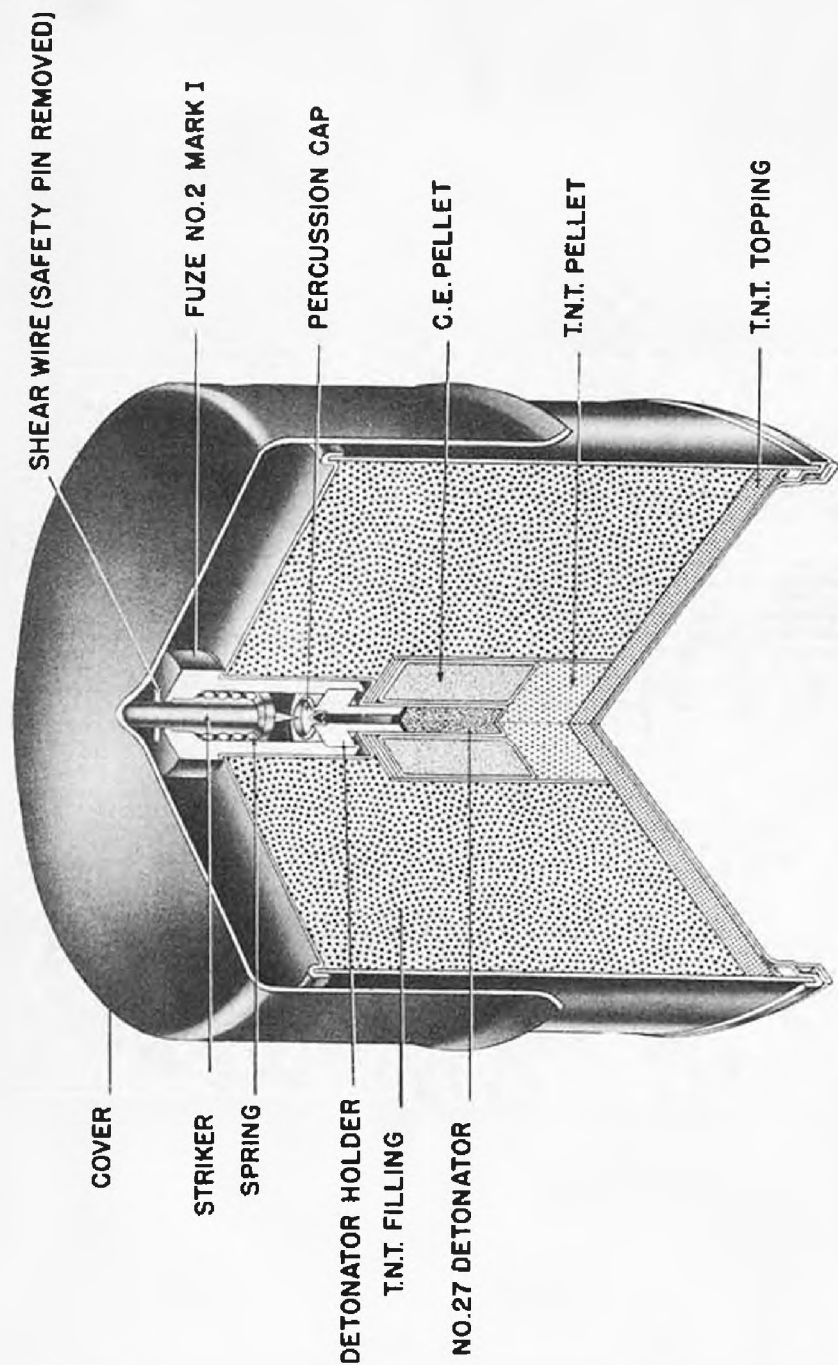

A / TK. MINE

G. S. MK. IV

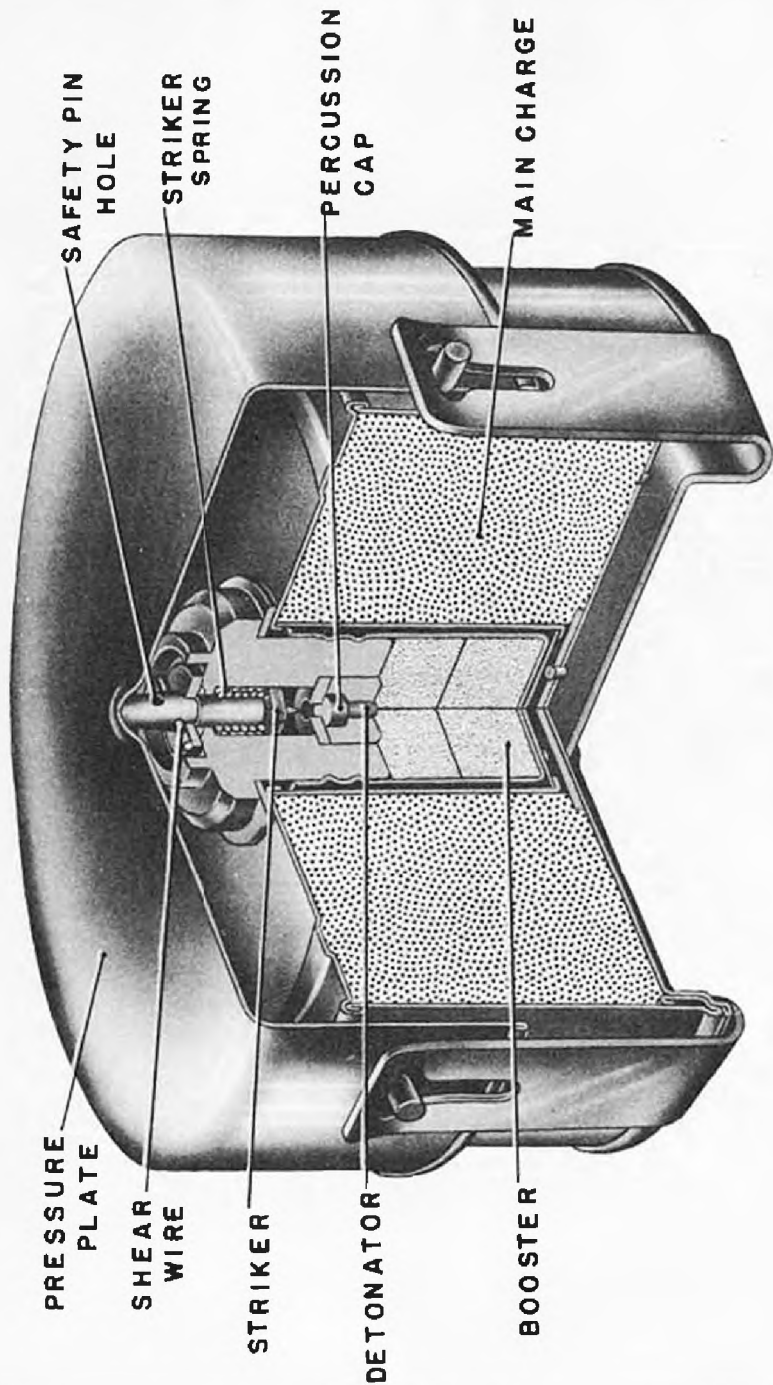

DIAMETER 8 in.
HEIGHT 5 in.
TOTAL WEIGHT 12-1/2 lbs.
EXPLOSIVE WEIGHT 8-1/4 lbs.
EXPLOSIVE T.N.T. or Baratol.
MATERIAL Steel
COLOR Khaki-green.
FUZE Mine, contact, A/T, No. 3
Mk I.
PRESSURE REQUIRED 350 lbs.

BRITISH MINE

G.S. MK. IV

(ANTI-TANK)

(SERVICE)

USE: Defense against armored cars, tanks, and other vehicles. Disables tanks and vehicles.

COMPONENTS: The G.S. Mk IV mine has three principal components: the loaded mine body, the pressure plate, and the fuze. The pressure plate covers the entire top of the mine and is attached to the mine body by four pins which engage in four slots in metal clips attached to the body. During normal shipment and storage, adhesive tape binds the pressure plate to the mine body.

(a) Mine Body: The mine body is cylindrical in shape and contains a central well for the insertion of the fuze. Between the central well and the outside casing of the mine is located the explosive main charge.

(b) Fuze, Mine, Contact, A/T, No. 3 Mk I: This fuze operates on the shear pin principle, and consists merely of a spring-loaded striker retained by a shear wire. Below the striker is located a percussion cap and detonator inserted in two C.E. booster pellets. All components, striker mechanism, cap and detonator, and booster, are contained in the fuze body. Pressure on the pressure plate forces the striker through the shear wire, and the striker spring then forces the striker into the percussion cap, firing the mine.

ASSEMBLY & ARMING: Remove the adhesive tape binding the pressure plate to the mine body, and then remove the pressure plate. Place mine in the ground and remove paper seal over fuze well. Inspect fuze to make certain shear pin is in position, then insert the fuze and remove the safety pin. Replace the pressure plate. **CAUTION!** Do not use force when attempting to remove safety pin; if it does not come away easily, discard the fuze and use another.

NEUTRALIZATION: To neutralize this mine, remove the pressure plate and insert a safety pin in the safety pin hole in the striker. Remove fuze from fuze well. Lift the mine from the ground and replace the pressure plate.

RE-ARMS: 1. If mine is to be re-used, inspect the fuze to make certain that the shear pin is in position and not cut or partially cut.

A/TK. MINE

G.S. MK. V

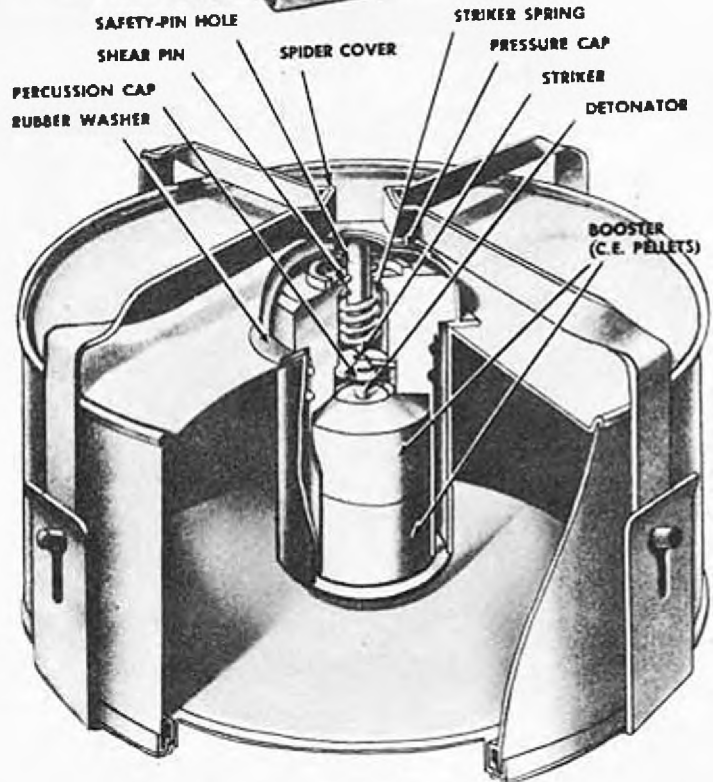
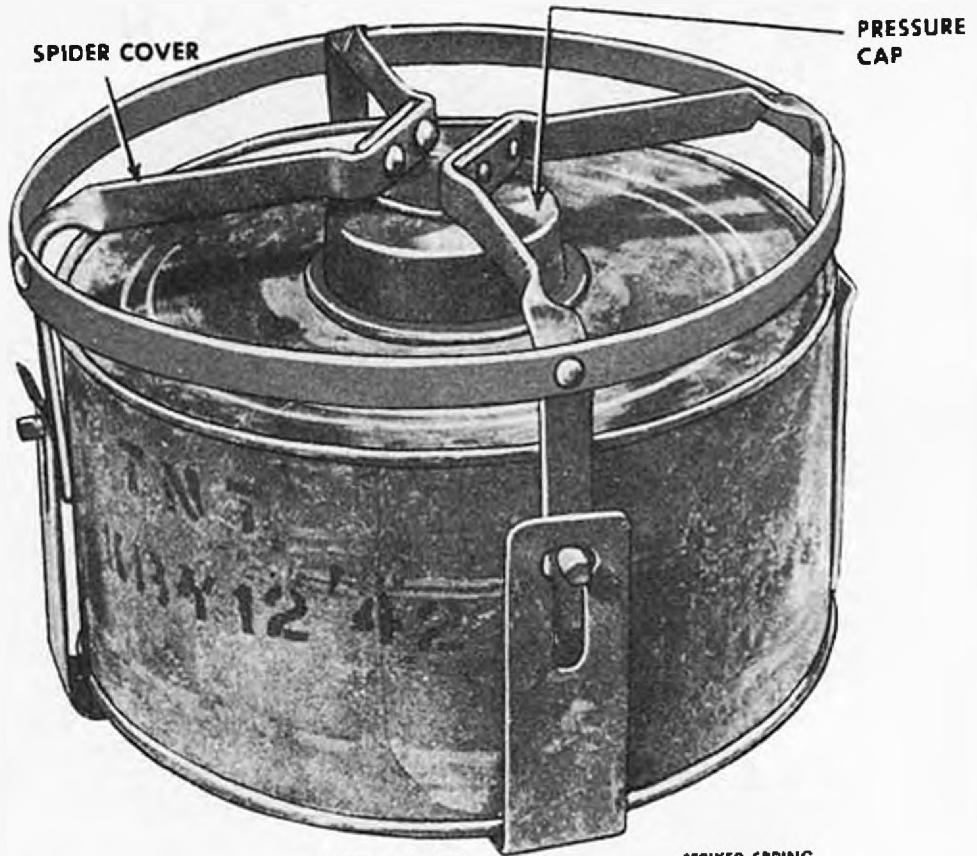

A/TK. MINE E. P. MK. II

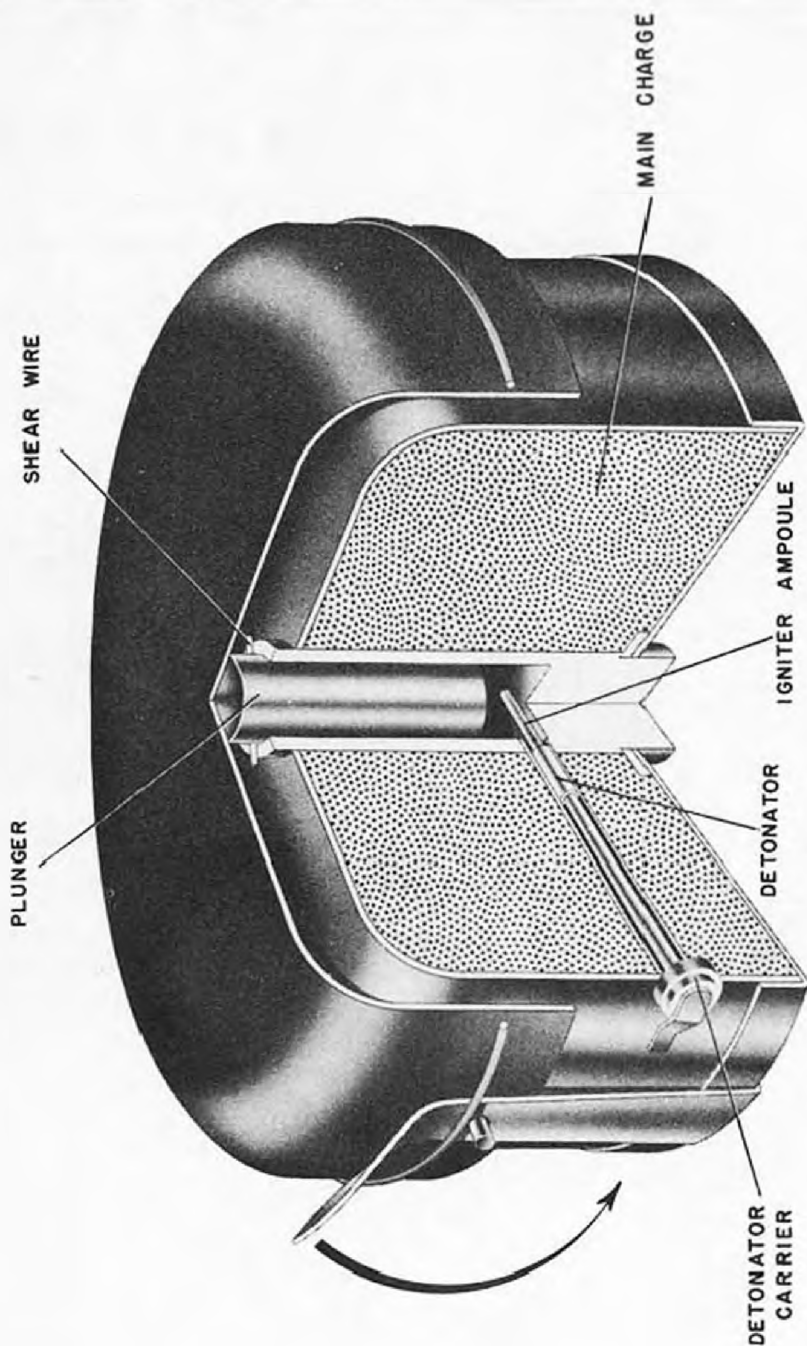

DIAMETER 10 in.
 HEIGHT 4 in.
 TOTAL WEIGHT
 EXPLOSIVE WEIGHT 4-1/2 lbs.
 EXPLCSIVE
 MATERIAL Steel
 COLOR
 FUZE E.P. Mk II Mine Fuze
 PRESSURE REQUIRED.

BRITISH MINE**E.P. MK. II**

(ANTI-TANK)

(OBSOLETE)

USE: Defense against armored cars, tanks, and other vehicles.

COMPONENTS: This mine consists of three, principal parts: the loaded mine body, the mine cover, and the mine fuzing arrangement. The mine cover is mushroom-shaped and is attached to the mine body by four hooked straps which engage a wire fastened to the bottom of the mine cover.

(a) Mine Body: The mine body is a mushroom-shaped container with a central fuze well. On the side of the mine body near the base is located a channel which leads into the central well. This channel is closed by a small metal tab during shipment and storage.

(b) Fuze, Mine, A/T, E.P. Mk II: This mine fuze consists of two separate parts. The first, the plunger system, consists of a plunger inserted into the central well and retained by a shear pin. The second part consists of a detonator and ampoule cartridge inserted in the channel in the side of the mine body and held in position by the metal tab. Pressure on the mine forces the plunger through the shear pin and down against the ampoule cartridge. The cartridge is crushed, causing a chemical reaction which fires the detonator into which it is inserted, firing the mine.

ASSEMBLY & ARMING: Insert ampoule cartridge, red end first, into the open end of a No. 8 detonator and seal with luting. Replace the assembly in the detonator box. When ready to lay the mine, remove the steel rod from the hole in the mine body and insert the detonator assembly, ampoule end first, without using force. Bend the metal tab over the end of the assembly and place mine in the ground.

NEUTRALIZATION: E.P. Mk II mines should never be neutralized unless absolutely necessary. They can be disarmed if the detonator assembly will come away easily without using force, but are better destroyed in place.

REMARKS: 1. Once laid, these mines are not to be used again even if disarmed.

A/TK. MINE E.P. MK. V

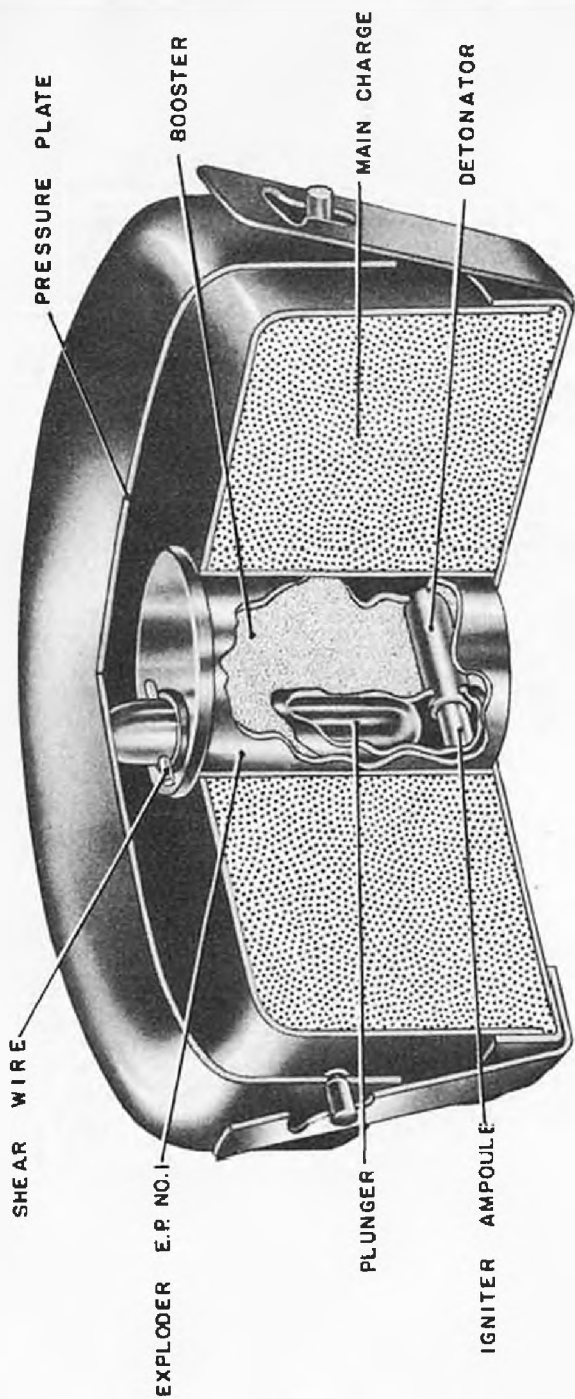

DIAMETER 8 in.
 HEIGHT 2-1/2 in.
 WEIGHT 8 lbs.
 EXPLOSIVE WEIGHT 4-1/2 lbs.
 EXPLOSIVE T.N.T.
 MATERIAL Sheet metal.
 COLOR
 FUZE Exploder E.P. No. 1 or No.2.
 PRESSURE REQUIRED 250-350 lbs.

BRITISH MINE

E.P. MK. V

(ANTI-TANK)

(OBSCOLESCENT)

USE: Defense against armored cars, tanks, and other vehicles. The mine will break the tracks of light or medium tanks and disable vehicles.

COMPONENTS: The E.P. Mk V mine consists of three principal components: the loaded mine body, the exploder mechanism, and the mine cover. The cover is fastened to the mine body by three pins which engage slots provided in three retaining straps attached to the mine body.

(a) Mine Body: The mine body is mushroom-shaped and contains a central well for the insertion of the special exploder.

(b) Exploders, E.P., No. 1 & No. 2: This fuze functions on the shear wire principle. In effect, it is nothing more than a miniature E.P. Mk II mine. It consists of a fuze body with a well in the top off-center for the insertion of a plunger, which is packed separately in the same box as the rest of the exploder mechanism. This plunger is retained by a shear wire. In the side of the exploder body, near the base, is a channel for the insertion of the ampoule cartridge-detonator combination. The fuze functions when pressure on the mine cover forces the plunger through the shear wire and down on to the ampoule cartridge. The ampoule is crushed, causing a chemical reaction which fires the No. 8 detonator. The booster charge, also located in the exploder body, is then exploded, setting off the main charge of the mine.

ASSEMBLY & ARMING: Lay the mine in the ground and remove the cover. Place an exploder in the inverted cover (to keep dust, etc., from the plunger), and insert an ampoule, red end first, into a No. 8 detonator. Fill the open end of the detonator flush with luting. Insert this end of the detonator in the hole in the side of the exploder body. Slide home and seal in place with more luting. Grease the exploder before inserting in the fuze well of the mine. Refit the cover.

NEUTRALIZATION: To neutralize this mine, remove the mine cover without putting any downward pressure on the cover, then lift the exploder from the exploder well of the mine. Remove the plunger from the exploder. Lift the mine and replace cover.

REMARKS:

A/TK. MINE E.P. MK. VI

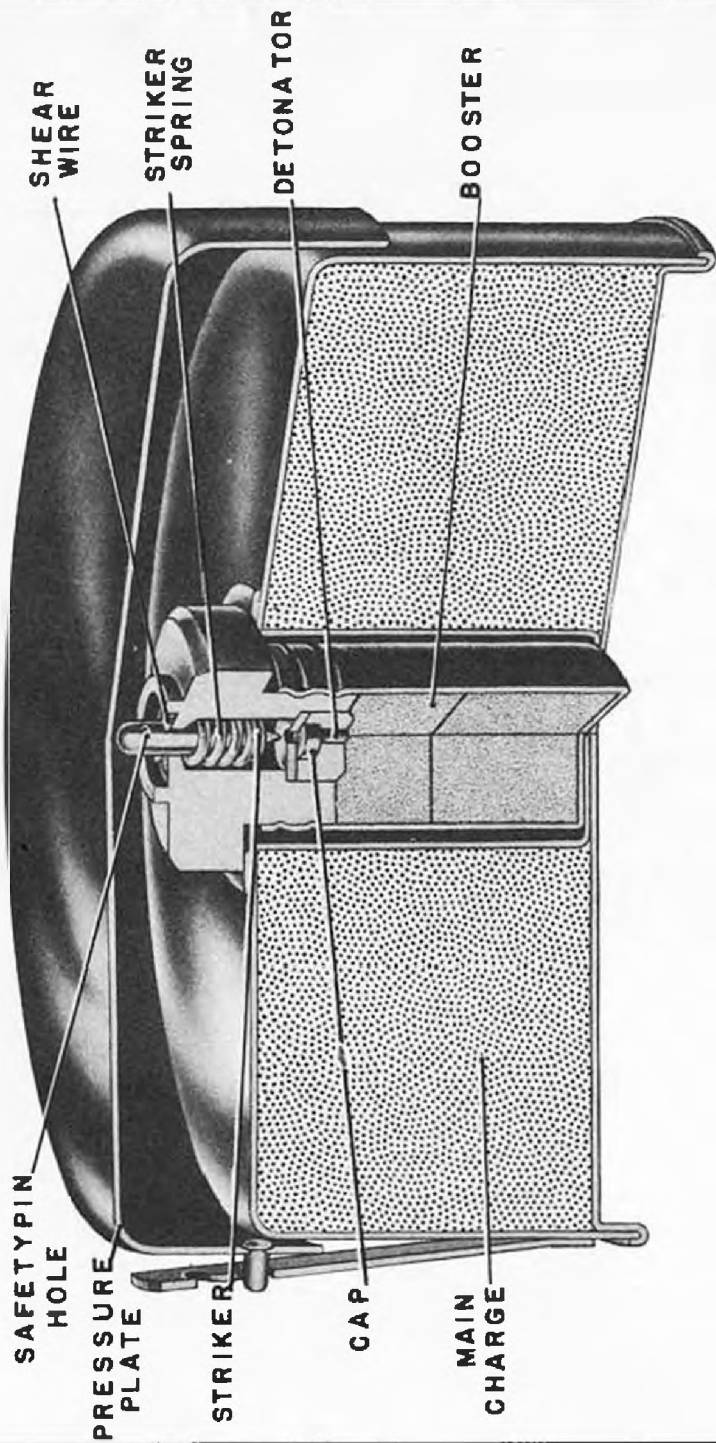

This Page is Blank

DIAMETER 8 in.
 HEIGHT 2-1/2 in.
 WEIGHT
 EXPLOSIVE WEIGHT 120 grains.
 EXPLOSIVE G-20 gunpowder.
 MATERIAL Sheet metal
 COLOR
 FUZE Exploder E.P. No. 1
 PRESSURE REQUIRED 250-350 lbs.

BRITISH MINE

PRACTICE

E.P. NO. 3

(ANTI-TANK)

(OBSOLESCENT)

(For Practice E.P. No. 2, see
REMARKS below)

USE: Practice minefields.

COMPONENTS: This mine has four principal components: the mine body, the mine cover, the exploder mechanism, and the "Thunderflash" gunpowder charge. The mine cover is fastened to the body by three pins which engage slots provided in three retaining straps attached to the mine body.

(a) Mine Body: The mine body is mushroom-shaped and contains a central well for the insertion of the special exploder. A hole is drilled in the side of this well near the bottom to allow passage of a short length of instantaneous fuse. Three 1 inch holes, equi-spaced, are drilled in the top of the mine body to provide gas escape vents.

(b) Exploder, Practice, E.P. No. 1: This fuze functions on the shear wire principle. It consists of a fuze body with an off-center well in the top for the insertion of a plunger, which is retained by a shear wire. In the side of the exploder body, near the base, is a channel for the insertion of the ampoule cartridge and instantaneous fuse. The fuze functions when pressure on the mine cover forces the plunger through the shear pin and down on to the ampoule cartridge. The ampoule is crushed, causing a chemical reaction which fires the instantaneous RED fuse, which in turn sets off the "Thunderflash".

(c) "Thunderflash": The thunderflash is merely a container filled with 120 grains of G-20 gunpowder. It is connected to the exploder by 6 inches of RED instantaneous fuse. The explosion of the fuse and "Thunderflash" provide a realistic effect for practice purposes.

ASSEMBLY & ARMINO: Lay the mine in the ground and remove the cover. Inspect the plunger to make certain that the shear wire is intact and in position, and insert plunger in hole provided in top of exploder. Replace mine cover.

NEUTRALIZATION: Remove mine cover and plunger.

REMARKS: 1. Although this mine is not anti-personnel, the charge is by no means harmless, and due precautions should be taken in disarming, especially if the mine has been subjected to blast.

2. Mine, Practice, E.P. No. 2 (Anti-Tank): This mine is exactly similar to the No. 3 Mine, described above, except that a three foot length of Instantaneous RED fuse is substituted for the "Thunderflash".

GRENADE A/TK. NO. 75 MK. I

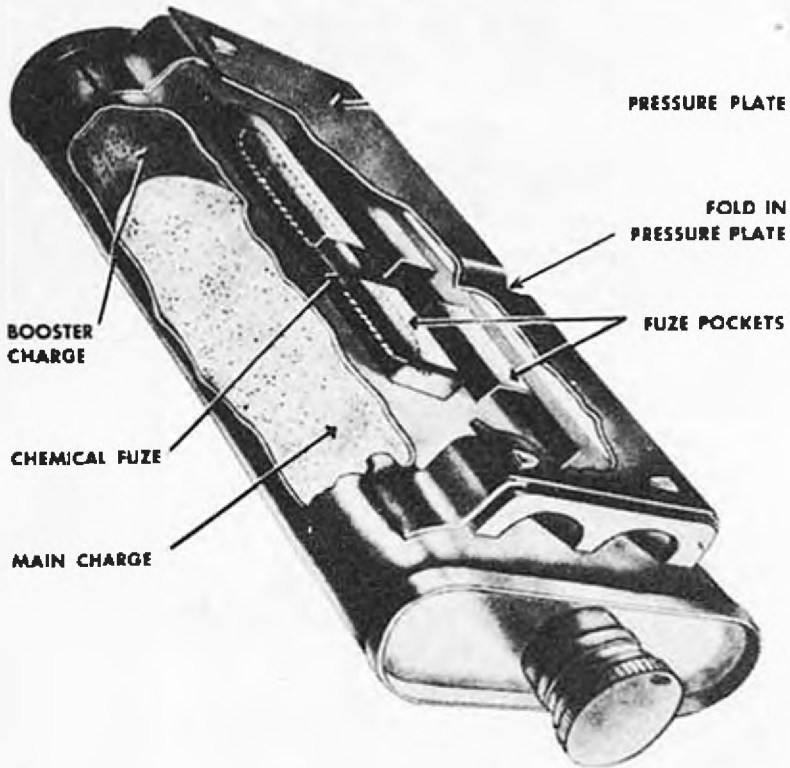
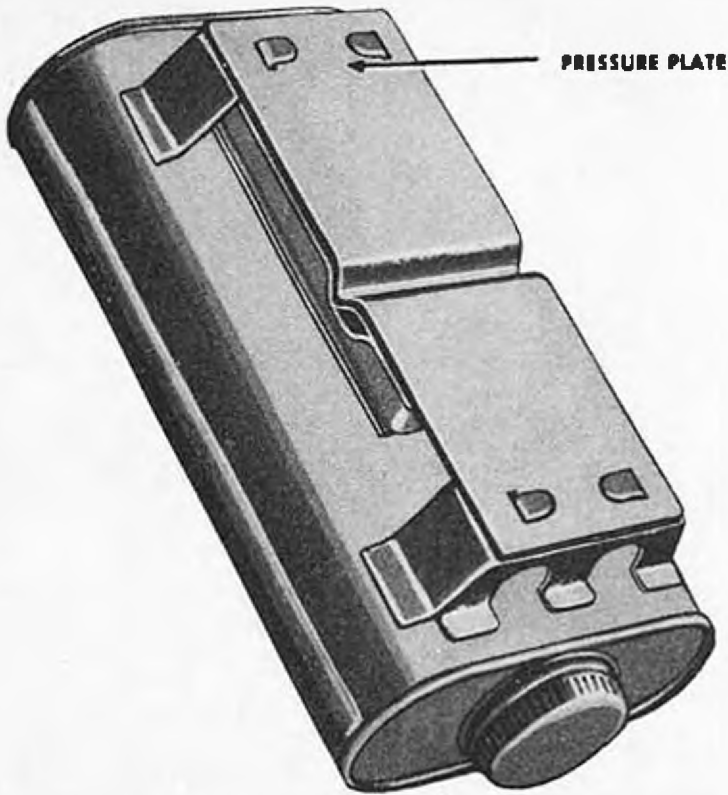

HEIGHT 1-7/8 in.
LENGTH 6-1/2 in.
WIDTH 3-5/8 in.
TOTAL WEIGHT 2 lbs. 4 oz.
EXPLOSIVE WEIGHT 1-1/2 lbs.
EXPLOSIVE Nobel's Ammonal 704E.
MATERIAL Steel
COLOR Service brown.
FUZE Special, chemical, by pressure plate.
PRESSURE REQUIRED 300 lbs.

BRITISH MINE

NO. 75

Hawkins Grenade
Mk I

(ANTI-TANK)

(SERVICE)

USE: Defense against armored cars, tanks, and other vehicles. This mine will disable light tanks and vehicles. Used principally for hasty minefields.

COMPONENTS: This mine has two component parts: the loaded mine body, and the chemical fuze.

(a) Mine body: The mine body consists of a 1 pt. capacity can. It is filled through a hole in one end, over which a cap is screwed and cemented. On one side of the can are two metal pockets, with slots cut in them, which form the detonator holders. These pockets have easily bendable metal tabs on one end to close them. The pressure plate is supported above the detonator holders by two brackets, one on each end of the can. A fold in the pressure plate is centered immediately above the cut-away slots in the middle of the detonator holders.

(b) Chemical Fuze: Two chemical fuze units are used with each grenade. Each unit consists of an igniter and a detonator. The igniter, containing a chemical composition, is made of steel, painted red, and has a small rubber tube rolled over one end. The detonator is an aluminum tube, open at one end and smaller in diameter than the igniter.

ASSEMBLY & ARMING: Lay the mine with the long side parallel to the line of probable enemy approach. Insert the detonator into the igniter ampoule, open end first, and fasten them together by unrolling the rubber sleeve over the detonator. Insert the two fuzes into the fuze pockets under the pressure plate, pushing the detonator end in first and insuring that red paint is visible in the slot in the fuze pocket. Close the flaps at the ends of the pockets.

NEUTRALIZATION: Open flaps of fuze pockets and remove the fuzes. Take the fuze assemblies apart. Store the detonator and the igniter separately.

FUNCTIONING: Pressure on top of the mine causes the pressure plate to bend. The fold in the pressure plate crushes the vial in the igniter. The resulting chemical reaction of the igniter ingredients produces a flame which sets off the detonator and fires the mine.

REMARKS:

1. This mine can be re-used as often as desired. Inspect the igniter to ascertain that it has not been crushed.
2. The No. 75 A Mine: This mine is distinguishable from the No. 75 by the letter "A" stencilled on the side of the mine body. It differs from the No. 75 mine only in its filling, which is military ammun. The mine is only 80% as powerful as the No. 75.

GRENADE A/TK. NO. 75 MK. II

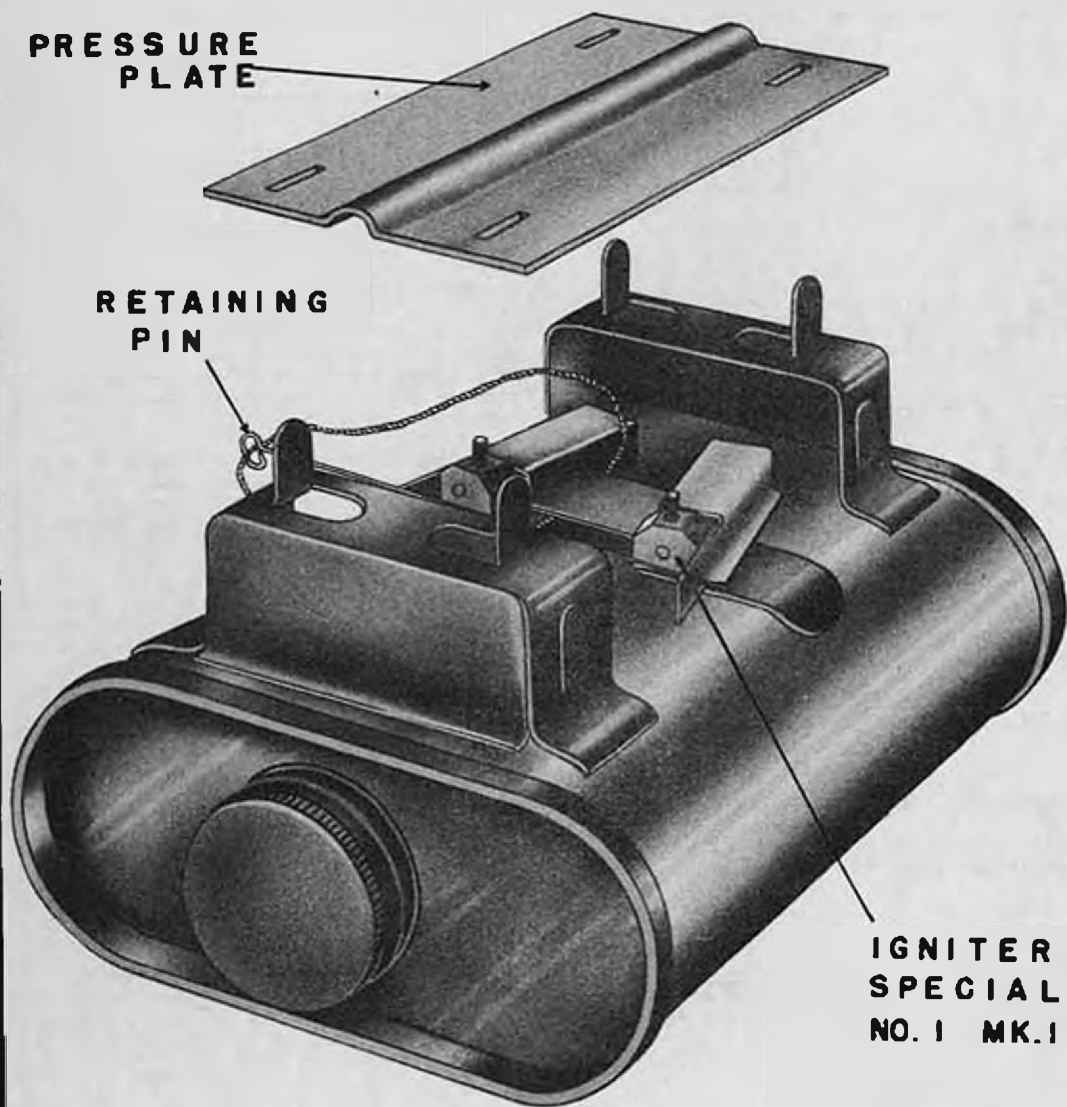

This Page is Blank

SECTION II

BRITISH ANTI-PERSONNEL MINES & FUZES

SHRAPNEL MINE MK. II

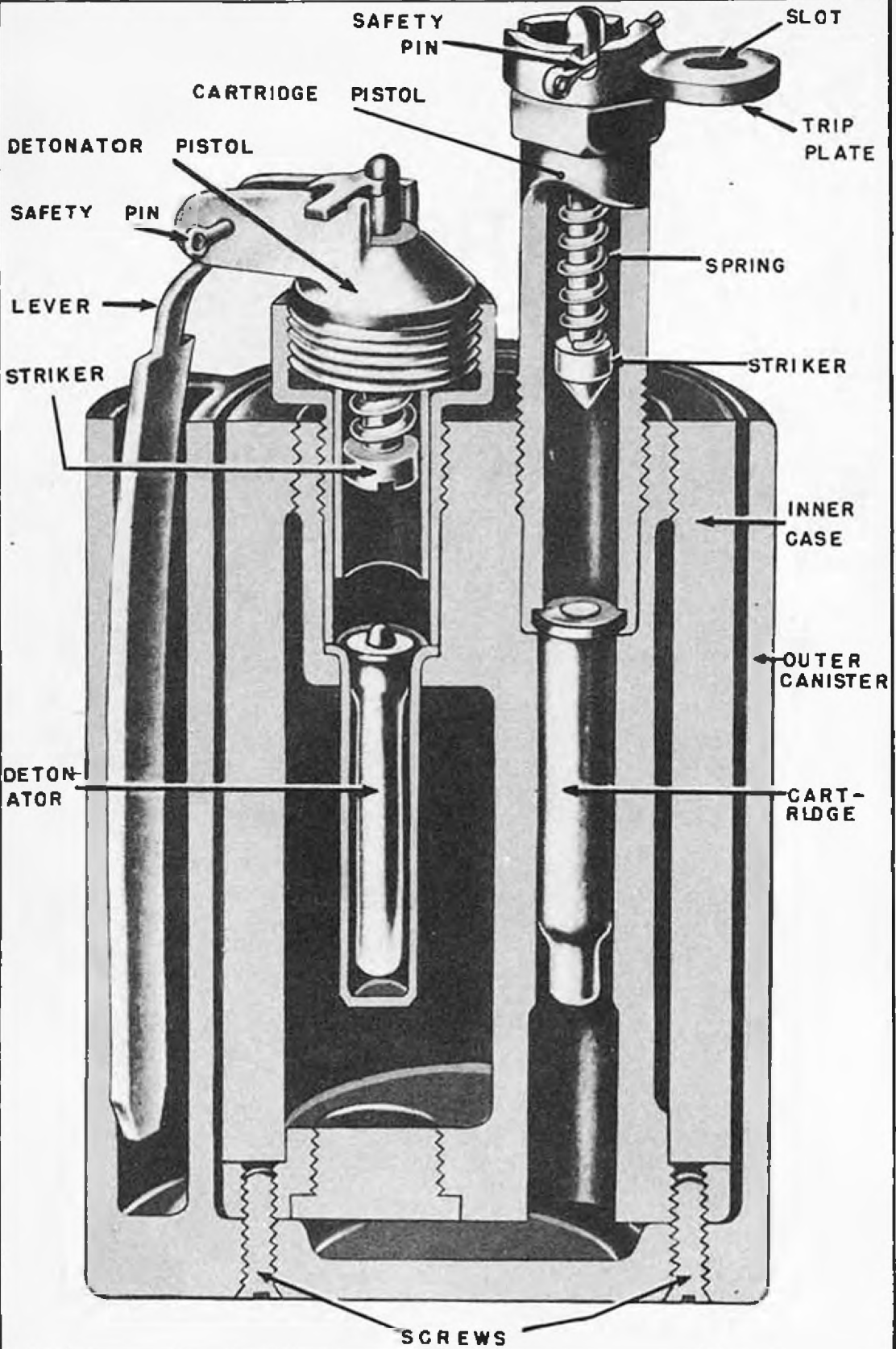

RESERVED

DIAMETER 3-1/2 in.
 HEIGHT 5-1/2 in.
 TOTAL WEIGHT 10 lbs.
 EXPLOSIVE WEIGHT 1 lb.
 EXPLOSIVE Amatol
 MATERIAL Case: Steel
 COLOR Yellow
 FUZZ Special
 PULL REQUIRED 4 lbs.

SHRAPNEL

SHRAPNEL MK. I & II

(ANTI-PERSONNEL)

(SERVICE)

(For Shrapnel Mk I, see REMARKS below)

USE: This mine is a bounding anti-personnel mine designed to cause casualties up to 30 yds.

COMPONENTS: The mine consists of the following component parts: the outer mine canister, the inner case, the detonator pistol mechanism, and the cartridge pistol mechanism.

(a) Outer Mine Canister: The canister is nothing more than a container for the inner case and acts as a small mortar to propel the inner case into the air. The inner case rests on a shoulder in the bottom of the outer canister, and below this shoulder in the canister is a small recess acting as an expansion chamber for the propellant gases. A long recess is located on the outside of the canister into which the lever of the detonator pistol slides.

(b) Inner case: The inner case is a cylindrical container for the explosive charge. Two holes are located in the top of the inner case, one passing completely through the case for the insertion of the cartridge pistol, the other leading into the explosive charge for the insertion of the detonator pistol mechanism. During normal shipment and storage the inner case is held in the outer canister by two screws passing through the bottom of the canister into the case. These screws must be removed from the mine before it is laid.

(c) Detonator Pistol Mechanism: The detonator pistol is the actuating mechanism for the explosive charge of the mine. It consists of a cylindrical body containing a spring-loaded striker retained by a small fork attached to the end of a long lever arm. The lever is held in the retaining position both by a safety pin and a long recess in the outer canister into which it fits. When the lever is released, the striker is forced by its spring into a detonator inserted in a well beneath the pistol.

(d) Cartridge Pistol Mechanism: The cartridge pistol is the activating mechanism for the mine. It consists of a cylindrical body housing a spring-loaded striker. This striker is retained by a fork-shaped trip plate which fits under a shoulder on the top of the striker and above the top of the fuze body. A slot for attaching a trip wire is provided in the trip plate. A safety pin passes through the top of the striker and also through a groove cut in the trip plate, preventing the trip plate from being withdrawn.

ASSEMBLY & ARMING: First make certain that the two transit screws holding the inner case in the outer canister are removed. Unscrew the cartridge pistol with the spanner provided. See that cartridge recess is clear and insert ballistite cartridge provided with each mine. Replace the cartridge pistol and screw tight, making certain that safety pin is secure. Remove the detonator pistol, making certain that the safety pin is in place. Inspect the socket to see that it is clear, and insert the detonator, small end first, so that the cap end rests on a shoulder in the socket. Replace the detonator pistol so that its firing lever engages in recess on outer canister. Make certain safety pin is secure. Place mine in ground and attach a loose trip wire to the cartridge pistol. Remove detonator pistol safety pin, then remove cartridge pistol safety pin. If safety pin cannot be withdrawn easily, release tension and reset the trip plate.

NEUTRALIZATION: Replace cartridge pistol safety pin, then replace detonator pistol safety pin. Cut the trip wire, then disarm the mine by reversing the procedure for arming, removing detonator and cartridge.

FUNCTIONING: A pull of four pounds or more on the trip wire will remove the trip plate from the cartridge pistol, allowing the striker spring to force the striker into the cartridge located beneath the pistol. The explosion of the ballistite cartridge provides the propellant force which throws the inner case into the air. When the inner case leaves the outer canister, the lever arm is released, freeing the striker in the detonator pistol, which then is forced into the detonator located below the pistol. The explosion of the detonator fires the main charge of the mine.

REMARKS: 1. Mine, Shrapnel, Mk I: The Mk I mine is the earlier issue of the Shrapnel mine and differs from the Mk II only slightly, as follows:

SHRAPNEL MINE MK. I

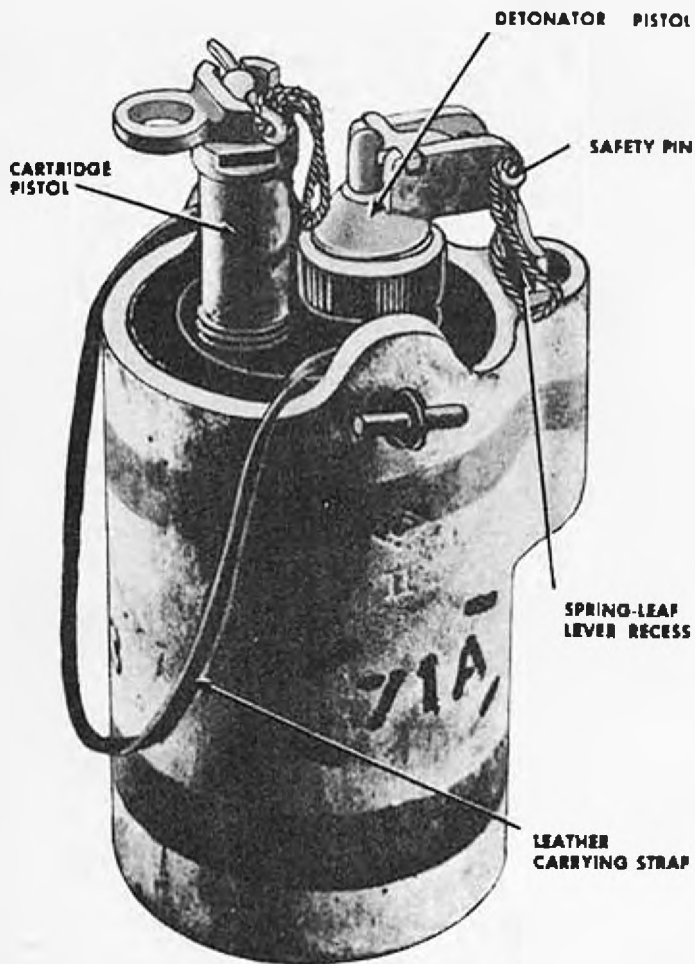

BRITISH**SHRAPNEL
MK. I & II**

(SERVICE)

(continued.)

REMARKS (cont'd):

(a) The Mk I spring lever is shorter than that provided for the Mk II mine, and the recess for it in the outer canister does not extend the full length of the mine.

(b) The Mk I mine has a leather carrying strap.

(c) The detonator of the Mk I mine has a slight delay action; That of the Mk II is instantaneous.

2. Before re-using a shrapnel mine, test as follows: After disarming the pistols, lift the mine and examine externally. In removing cartridge and detonator, note any tendency to stick. If either cartridge or detonator cannot be removed, discard the mine. Examine the cartridge and detonator for corrosion. Examine the empty pistol sockets and cartridge and detonator recesses for corrosion and wetting. The detonator socket particularly should be examined for blue or green incrustation. If found, discard the mine. Test some of the removed ballistite cartridges and detonators by firing separately.

MINE A/P NO. 3 MK. I

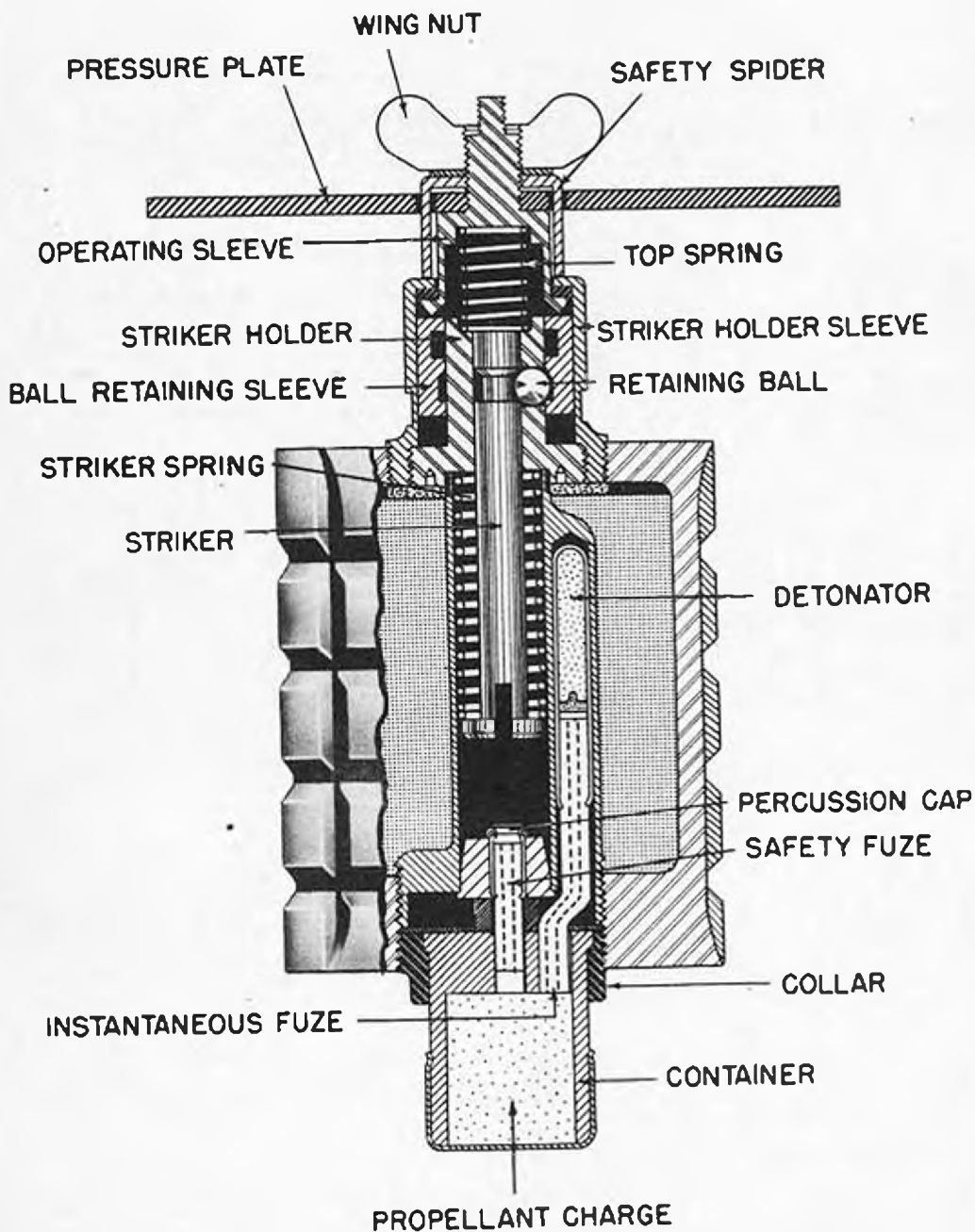

DIAMETER (BODY) 2-1/2 in.
 HEIGHT 6-1/8 in.
 TOTAL WEIGHT
 EXPLOSIVE WEIGHT 3 oz. 7 drs.
 EXPLOSIVE T.N.T.
 MATERIAL Steel
 COLOR Black
 MARKINGS 1/2" ring of red cross-
 crosses near top; 1/2"
 green ring near base.
 FUZE Special
 PRESSURE REQUIRED At center of plate: 38 lbs;
 At edge of plate: 7 lbs.

BRITISH MINE

NO. 3 M K. I

(ANTI-PERSONNEL)

(OBSCOLESCENT)

USE: This mine is a bounding anti-personnel mine. The effective lethal range is estimated at 30 yards radius.

COMPONENTS: This mine has four principal components: the loaded mine body, the pressure plate, the special percussion fuze, and the base propellant charge. The pressure plate is a steel disc 4 inches in diameter threaded to the top of the fuze mechanism.

(a) Mine Body: The mine body consists of a cylindrical corrugated steel outer casing containing the explosive main charge, and a central tube, threaded into the base of the mine body, for the insertion of the fuze mechanism and the propellant charge. A long tubular recess is provided in one side of the center tube for the insertion of the instantaneous fuze and detonator.

(b) Fuze Mechanism: The fuze mechanism consists of a striker holder sleeve, one end of which is threaded into the top of the mine, while the other end is crimped over to retain the operating sleeve. Threaded to the inside of the striker holder sleeve is the tubular striker holder. The striker rides in this holder, and the striker spring butts against the lower edge of the holder. In the upper part of the striker holder are three retaining balls which engage in a groove in the striker and retain it in the cocked position. The balls are kept from moving outward by the ball retaining sleeve. Two annular grooves are cut on the inside of the ball retaining sleeve; the upper one is deep, the lower one shallow. In the cocked position, the retaining balls ride in the lower groove, which is shallow enough to force the balls into the striker groove, but sufficiently deep to prevent the ball retaining sleeve from moving freely inside the striker holder sleeve. Immediately above and resting on the retaining sleeve is the operating sleeve. This sleeve is held upwards by the top spring, but is prevented from being forced out of the fuze by the turned edges of the striker holder sleeve. The top of the operating sleeve is threaded to receive the pressure plate. A safety spider with four prongs slips over the threaded part of the operating sleeve, and the prongs pass through four holes in the pressure plate and bear against the top of the striker holder sleeve. A wing nut holds the safety spider securely in position. When the safety spider is in position, the operating sleeve is prevented from moving, thus making the mine safe. The safety spider and wing nut are removed when the mine is armed. The fuze functions when sufficient pressure is placed on the pressure plate to tilt or force downwards the operating sleeve. This, in turn, forces the ball retaining sleeve down until the retaining balls can move into the upper deeper groove. The striker is then released.

(c) Base Propellant Charge: The base assembly consists of a threaded collar into which is fitted the propellant charge container. This container holds a charge of about 100 grains of G. 20 Gunpowder, and is closed at the bottom by a cup which is crimped into a groove on the outside of the container. Two holes are drilled in the top of the container and lead directly to the gunpowder charge. The first hole contains a short length of safety fuse which leads to the percussion cap and priming composition. The second hole contains one end of the length of instantaneous fuze to which the detonator is crimped. Between the detonator and the instantaneous fuze are about 2½ grains of sulphurless meal powder, which provides a slight delay.

ASSEMBLY & ARMING: Place the mine in the ground on a drilled block of wood, to provide support. Pack earth around the mine, then remove the wing nut and safety spider, being careful not to exert any pressure on the pressure plate.

NEUTRALIZATION: Reverse the process outlined for arming the mine.

FUNCTIONING: When the striker hits the percussion cap, the safety fuse is ignited and burns from 1 to 2 secs., allowing sufficient time for the enemy to move forward and remove his foot from the mine. The flash from the safety fuse ignites the propellant charge and projects the mine into the air. Simultaneously, the flash from the gunpowder ignites the instantaneous fuze which fires the detonator when the mine is about 2 to 4 feet in the air.

REMARKS: 1. This mine was developed and produced by the Royal Engineers in India.

MINE A/P E.P. NO. 4

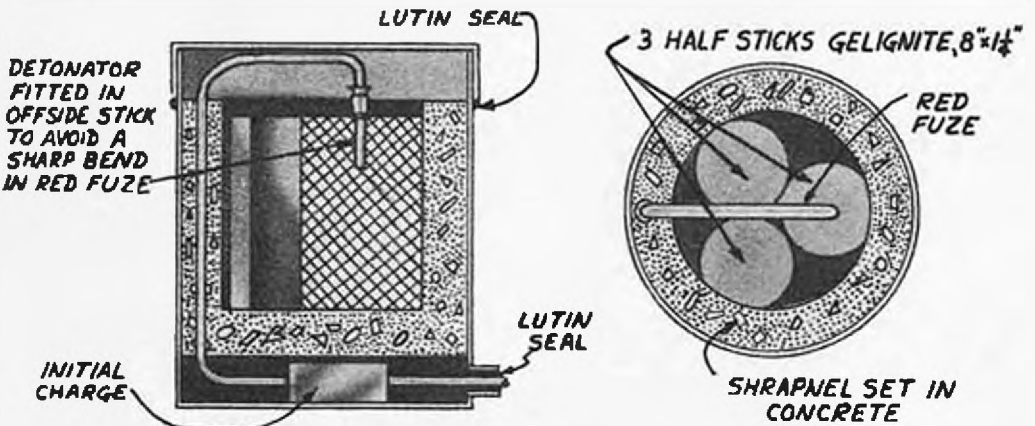
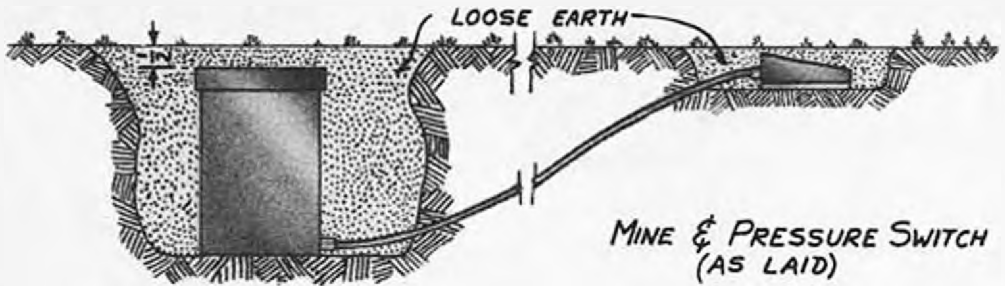

CHARGED READY FOR USE

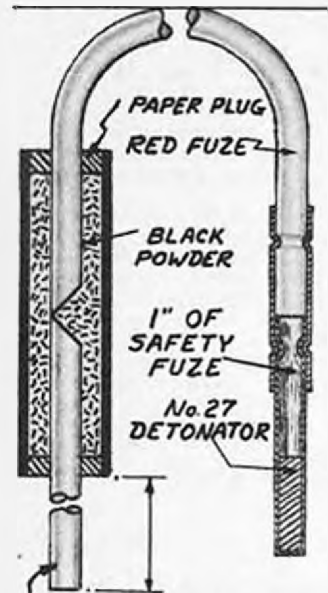

END SEALED WITH COMPOUND FUZE SEALING. CUT OFF 1/8" LENGTH OF FUZE BEFORE USING.

FUZE UNIT No. 1
(AS ISSUED)

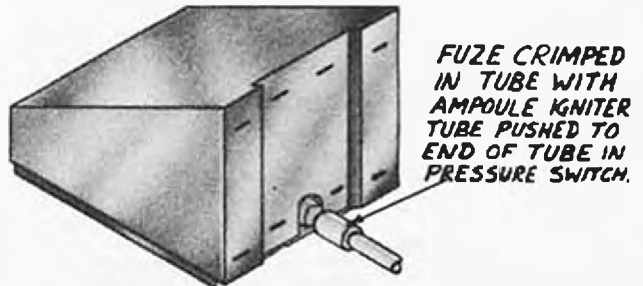
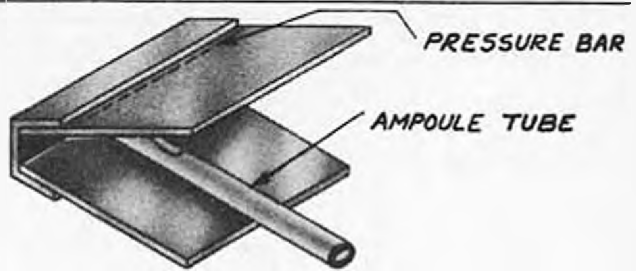

SWITCH, PRESSURE, E.P. No. 1, IN FIRING POSITION

DIAMETER 2-7/8 in.
 HEIGHT 4 in.
 WEIGHT 1 lb. approx.
 EXPLOSIVE WEIGHT 3/4 lb.
 EXPLOSIVE 3 sticks of Gelignite
 4" x 1 1/4" diameter.
 MATERIAL Sheet metal.
 COLOR
 FUZZ Fuze Unit No. 1 with:
 a) Any pull or pressure
 switch;
 b) Pressure switch, E.P.
 No. 1.

BRITISH MINE

E. P. NO. 4

(ANTI-PERSONNEL)

(OBSOLETE)

(For Pressure Switch, E. P. No. 1,
see REMARKS below)

USE: This mine is a bounding shrapnel mine designed for anti-personnel purposes. When the mine is fired, the bomb jumps from its container, comes to rest on the surface of the ground and explodes.

COMPONENTS: The E.P. No. 4 Mine consists of three components parts: the outer mine canister, the inner loaded mine case, and the special Fuze Unit No. 1.

(a) Outer Canister: The outer canister consists of a cylindrical sheet metal container for the inner loaded case. The outer canister acts as a sort of mortar from which the inner case is projected. A short tube projects from one side of the outer container near the bottom. The instantaneous fuze passes through this tube to the switch when the mine is laid. The top of the outer canister is closed by a lid.

(b) Inner Case: The inner loaded mine case contains shrapnel set in concrete around the sides and bottom. In the center of the case are located the three sticks of Gelignite which comprise the main explosive charge. Near one edge of the inner case is located a hold to allow passage of the instantaneous fuze.

(c) Fuze Unit No. 1: The fuze unit consists of a length of R&D Instantaneous Fuze. Toward the center of this length of fuze is fixed a charge of black powder, which serves to propel the bomb from the container. A No. 27 detonator is crimped to one end of the length of fuze. A one inch length of safety fuze intervenes between the detonator and the instantaneous fuze to provide the necessary delay. The other end of the instantaneous fuze is led through the tube in the base of the outer canister to the initiating switch. The fuze unit is shipped in the bomb, but not assembled.

ASSEMBLY & ARMING: Remove the lid from the mine, and withdraw the fuze unit and the inner case. Thread the detonator end of the fuze unit through the hole in the inner case. Thread the other end through the hole in the outer canister and draw it all the way through, lowering the inner case gently into the canister. Attach the trip or pressure mechanism to the fuze unit. Charge the bomb with three sticks of Gelignite; insert the detonator into one stick; and replace the lid of the mine.

NEUTRALIZATION: Cut the red fuze at the most convenient place. Neutralize the switch. Remove the lid from the outer canister and pull the detonator from the charge. Remove the inner case from the container and unthread the fuze unit.

REMARKS: 1. Although any British switch may be used with this mine, the switch designed especially for it is the Pressure Switch, E.P. No. 1. The switch consists merely of two steel plates hinged together. The upper plate carries a pressure bar, which, when the plates are forced together, crushes a chemical igniter ampoule which is contained in a tube on the lower plate. The end of this tube is open and is of suitable diameter to accept R&D Instantaneous Fuze. The fuze is inserted as far as possible, then crimped in place.

MINE A/P NO. 5 MK. I

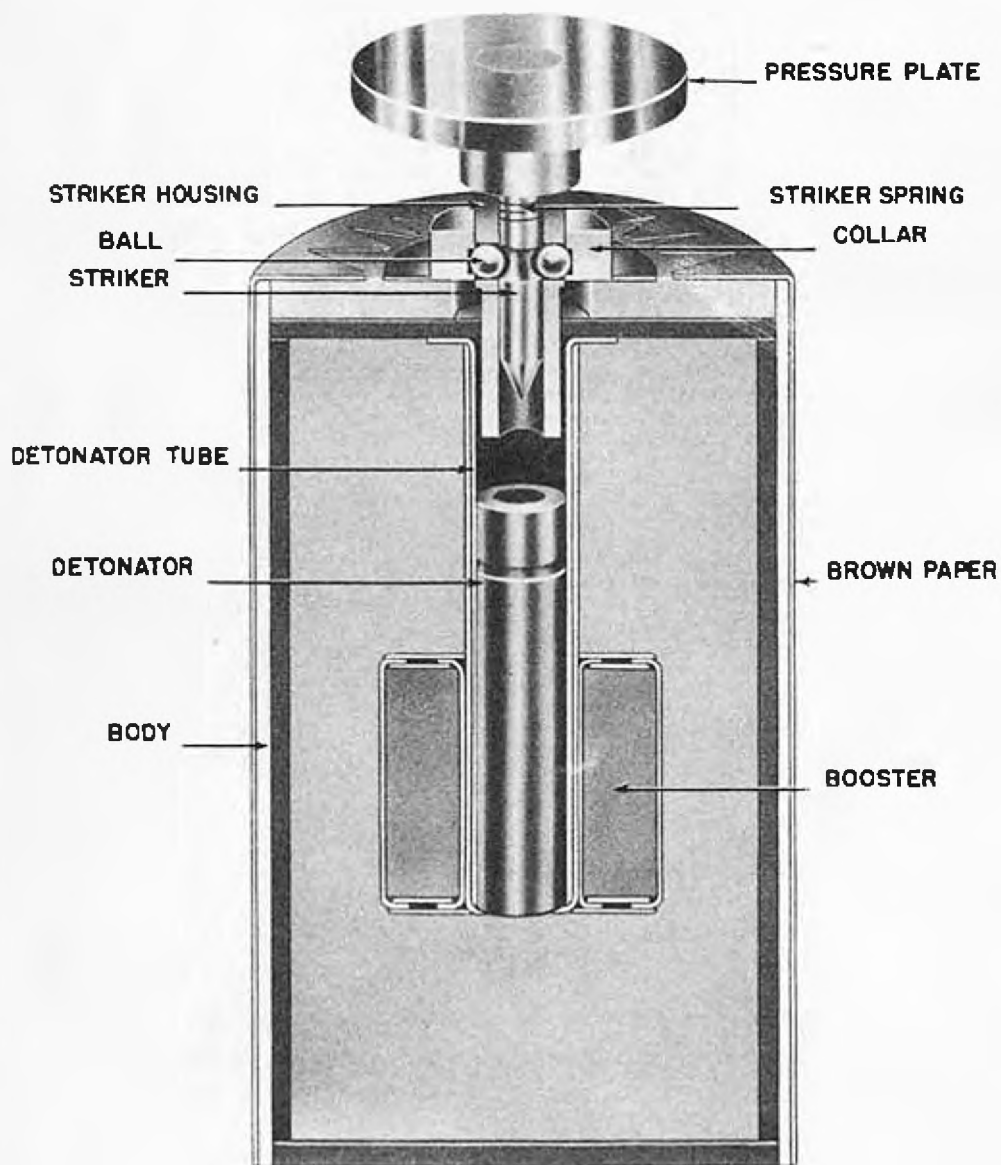

DIAMETER 2 in.
 HEIGHT 3-5/8 in.
 TOTAL WEIGHT
 EXPLOSIVE WEIGHT 6-3/4 oz.
 EXPLOSIVE a) 50/50 Pentolite
 b) 50/50 RDX/TNT
 MATERIAL Cardboard
 COLOR Varnished brown paper.
 FUZE Special
 PRESSURE REQUIRED Approx. 6 - 12 lbs.

BRITISH MINE

NO. 5 MK. I

(ANTI-PERSONNEL)

(SERVICE)

USE: This mine is a non-metallic anti-personnel mine, designed to prevent detection by means of mine detectors. The only metallic parts used in its construction are the detonator, spring, balls, and striker.

COMPONENTS: The mine consists of two principal components: the loaded mine body and the fuze mechanism.

(a) Mine Body: The mine body consists of a cardboard cylinder and ends, containing the explosive main charge. A central well is provided for the insertion of the fuze. A 5 dram perforated C.2. pellet booster is placed around the lower portion of the central well.

(b) Special Fuze: The waterproof igniter unit used is a No. 89 Mk I detonator consisting of a 1.7 grain igniter cap spun into the open end of a No. 8 or No. 27 detonator. A hollow ebonite rod containing a spring-loaded striker comprises the striker unit. The striker is retained by two retaining balls which are held engaged in a groove in the striker by a collar which fits over the outside of the rod. The fuze functions when sufficient pressure is exerted on top of the igniter to force the rod down through the collar and release the retaining balls. This fuze unit is packed separately from but in the same crate as the mines in which it is to be used. During normal shipment and storage the mines contain a wooden plug in the fuze well.

ASSEMBLY & ARMING: Place the mine in the ground. Remove the wooden plug from the fuze well and insert a No. 89 detonator provided. Check the striker unit to make certain that it is properly assembled, and insert striker unit in fuze well above the igniter unit. Be careful to exert no pressure on the striker unit once it has been inserted in the mine.

NEUTRALIZATION: To neutralize this mine, carefully remove the striker unit, lift mine, and remove detonator-igniter unit.

REMARKS: 1. Because of the small effective pressure area of the striker unit, it is recommended that this area be increased by placing a small piece of wood, etc., above the striker after laying.

2. Due to the non-metallic construction of this mine and the small area, it will be very difficult to detect this mine either with detectors or by probing.

3. A circular steel pressure plate is provided with the later issues of this mine. The pressure plate has a small bush on its under surface which fits over the top of the ebonite striker housing. The use of this pressure plate will eliminate the non-detectable feature of the mine, but will increase the operating efficiency by increasing the pressure area.

4. When loaded with 50/50 Pentolite, a black band with a green band on either side is painted around the center of the mine. This is replaced by a single blue band when 50/50 RDX/TNT filling is used. In both cases, a red band is painted around the mine near the base.

MINE A/P IMPROVISED TYPE I

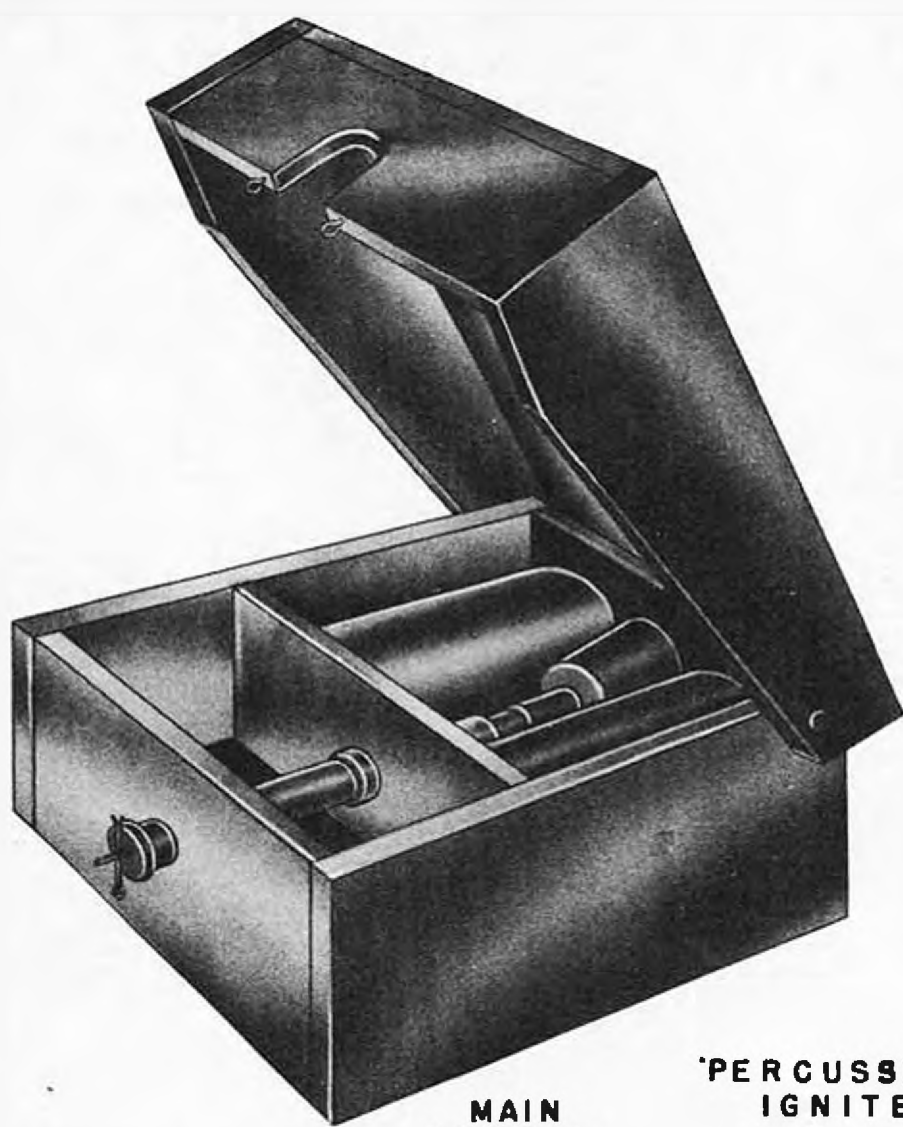

PERCUSSION
IGNITER
MAIN
CHARGE

DETONATOR
FUSE

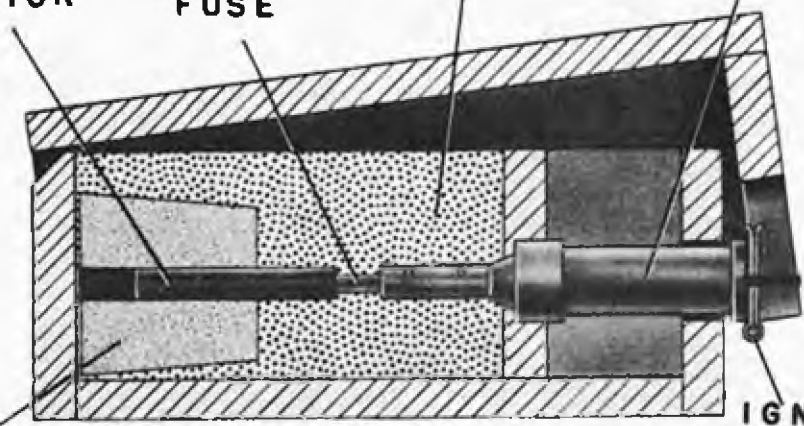

PRIMER

IGNITER
PIN

LENGTH 6 in.
 WIDTH 6 in.
 HEIGHT 2 in.
 TOTAL WEIGHT
 EXPLOSIVE WEIGHT 9 oz.
 EXPLOSIVE Nobel's "808"
 MATERIAL Wood
 COLOR
 FUZE Igniter, percussion, Mk III
 PRESSURE REQUIRED 2-1/4 lb.

BRITISH MINE

IMPROVISED TYPE I

(ANTI-PERSONNEL)

(SERVICE)

USE: This mine was designed and developed by the 38th Field Park Co. of the Royal Engineers, and is now being manufactured by them on a large scale.

COMPONENTS: This mine consists of two principal components: the loaded mine body, and the fuze unit.

(a) Mine Body: The mine body consists of a wooden box with a hinged cover. A bulkhead constructed in the box forms two compartments, the front one empty, the rear containing the explosive charge and primer. Holes are drilled in the front of the box and in the bulkhead to allow insertion of the percussion igniter. A slot cut in the front of the box lid fits down over the end of the igniter, and two small staples in the lid receive the arming pin which also passes through the hole in the igniter pin. Pressure on the lid will force out the igniter pin and fire the charge.

(b) Fuze Unit: The fuze unit consists of a standard British Percussion Igniter Mk III (See Page 71), a small length of orange instantaneous fuse, a No. 27 detonator, and a C.E. or Guncotton primer. Removal of the igniter pin allows the striker to hit the percussion cap, which ignites the orange instantaneous fuse. The fuse, in turn, sets off the No. 27 detonator, firing the primer and the main charge.

ASSEMBLY & ARMING: Lay mine in ground and place two 4 oz. charges of Nobel's "808" in the after compartment. Inspect igniter to make certain pin is securely in position, then insert short length of orange fuse in fuse adapter. Crimp a No. 27 detonator over other end of orange fuse, and insert the assembly in the holes provided in the mine body. Place a C.E. or Guncotton primer between the two charges of explosive and insert the No. 27 detonator in the lid of the mine, and insert the arming pin through the staples on the bottom of the lid and the hole in the igniter pin.

NEUTRALIZATION: To neutralize this mine, remove the arming pin, after making certain that the igniter pin is securely in position. Open the mine lid, and withdraw the fuze assembly from the mine. Separate the igniter from the detonator by cutting the length of orange fuse joining them. Remove the primer, and the explosive charges if desired.

REMARKS: 1. This mine is similar in action and appearance to the German SchuMino.

MINE A/P IMPROVISED TYPE II

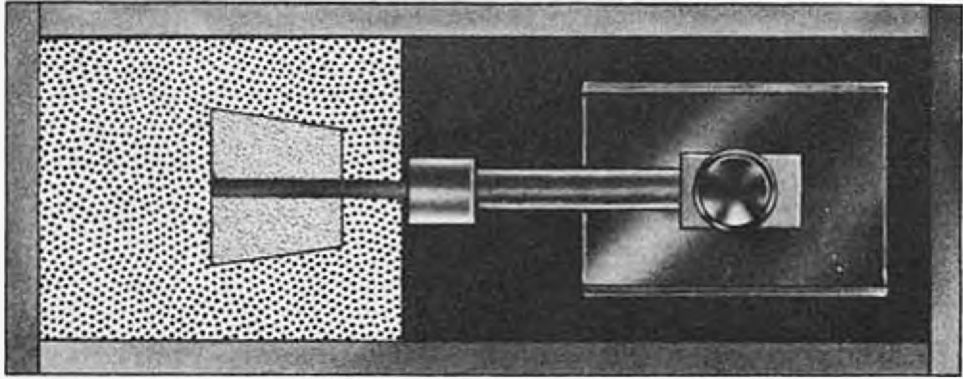

MAIN CHARGE

DETONATOR

PRIMER

WOODEN BLOCK

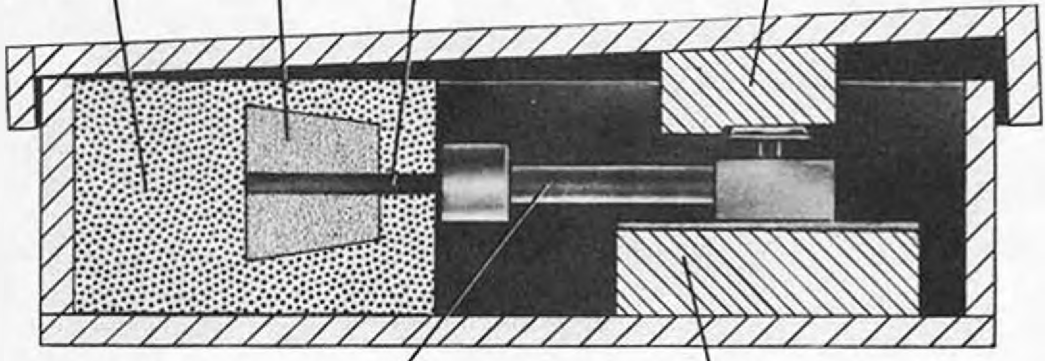

SWITCH
NO. 2
PRESSURE

WOODEN BLOCK

LENGTH 8 in.
 WIDTH 3 in.
 HEIGHT 2-1/2 in.
 TOTAL WEIGHT
 EXPLOSIVE WEIGHT
 EXPLOSIVE Nobel's "808"
 MATERIAL Wood
 COLOR British Switch, No. 2,
 Pressure, Mk I or II
 PRESSURE REQUIRED . . 30 to 40 lbs.

BRITISH MINE

IMPROVISED TYPE II

(ANTI-PERSONNEL)

(SERVICE)

USE: This mine was designed and developed by the 38th Field Park. Co. of the Royal Engineers, and is now being manufactured by them on a large scale.

COMPONENTS: The mine consists of two principal components: the loaded mine body, and the fuze unit.

(a) Mine Body: The mine body consists of a wooden box with a loose fitting lid. One half of the box contains a charge of Nobel's "808" explosive packed around a Guncotton primer. A standard British No. 2 Pressure Switch (See page 47) is mounted on a block of wood in the other portion of the box. Pressure on the lid of the box forces down the pressure head of the switch and fires the charge.

(b) Fuze Unit: The fuze unit consists of a standard British No. 2 Pressure Switch mounted on a block of wood in the mine box. A No. 27 detonator is placed in the adaptor of the switch and inserted in the C.E. or Guncotton primer around which the explosive is packed. Another small block of wood is placed on top of the pressure head of the switch, and the lid of the mine then rests on this block. Pressure on the pressure plate allows the striker to hit the detonator and fire the primer, which sets off the main charge of the mine.

ASSEMBLY & ARMING: To arm this mine, lay it in the ground and then open the mine lid. Place the removable pressure head in the switch and a wooden block over the pressure head. Close the lid of the mine, without placing any pressure on the lid.

NEUTRALIZATION: To neutralize this mine, open the mine lid and remove the pressure head from the switch. Remove mine from the ground.

REMARKS:

GRENADE A/P NO. 75

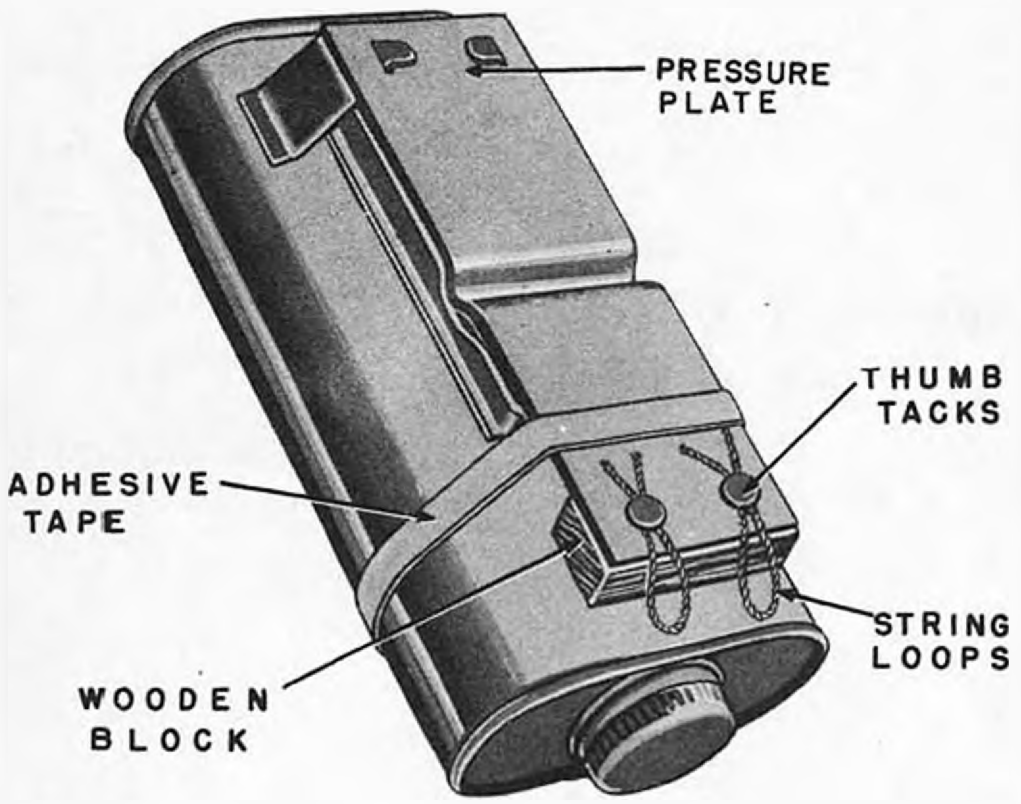

HEIGHT 1-7/8 in.
LENGTH 6-1/2 in.
WIDTH 3-5/8 in.
TOTAL WEIGHT 3 lbs.
EXPLOSIVE WEIGHT 1-1/2 lbs.
EXPLOSIVE Nobel's Ammonal 704
MATERIAL Steel
COLOR Olive drab
FUZE Special, chemical, by pres-
sure plate.
PRESSURE REQUIRED 10 lbs. approx.

BRITISH MINE

NO. 75

Hawkins Grenade Mk I

(Adapted for Anti-Personnel)

(SERVICE)

USE: This mine is a blast type anti-personnel mine. The mine should be laid just below the level of the ground, with a slight covering of soil or foliage for concealment. Care should be taken to insure that stones or small pieces of wood do not become lodged between the striker plate and the mine body. These mines should not be laid closer together than three feet to avoid sympathetic detonation.

COMPONENTS: A complete description of this mine as normally issued will be found on page 19. The description which follows will concern only the adaptations made to accomplish an anti-personnel effect.

One striker bracket has been removed and replaced by a small wooden block, as a safety device. This block is temporarily held in position by two thumb tacks through the slots in the pressure plate provided for the bracket clips. A band of adhesive tape around the whole mine positions the pressure plate.

ASSEMBLY & ARMING: The mine is armed in the usual way. The detonator is inserted in the igniter (open end to open end) and fastened by the rubber tube provided. Insert the complete assemblies into the pockets provided on top of the mine body, with detonator inwards. If armed correctly, the red of the igniter can be seen in the gap in the fuze pocket. Close cover tabs to prevent the detonators from falling out.

Lay the mine in the ground and remove the two thumb tacks by pulling up on the two string loops attached to them. Remove the wooden block. Utmost precaution should be taken to put no pressure on the mine pressure plate after it has been set.

NEUTRALIZATION: To neutralize this mine, raise pressure plate and reinsert wooden block, making it fast with thumb tacks. Open flaps on fuze pockets and remove the fuze assemblies. Take fuze assemblies apart, and store detonators and igniters separately.

REMARKS: 1. The Mk II Hawkins Grenade Mine (See page 21) can be similarly adapted for anti-personnel use.

MINE A/P ANTI-TIRE

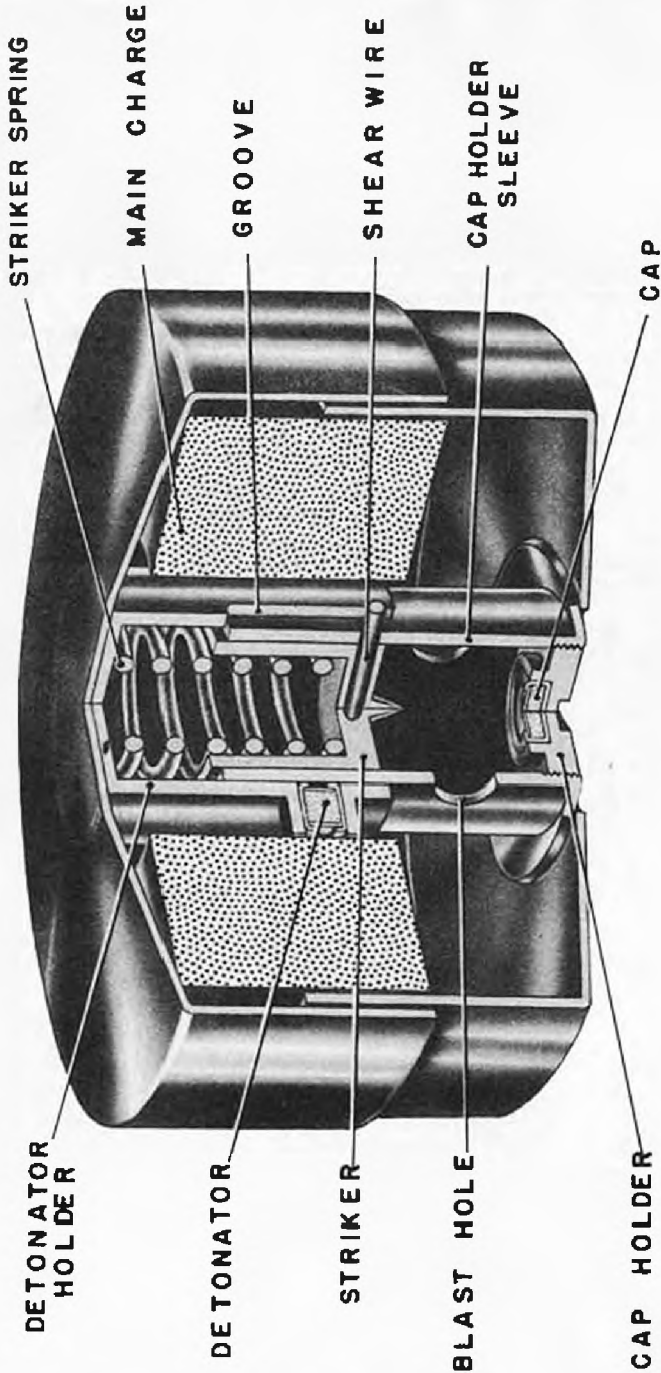

DIAMETER 2 in.
HEIGHT 1-1/8 in.
TOTAL WEIGHT 5 oz.
EXPLOSIVE WEIGHT 2 oz.
EXPLOSIVE
MATERIAL Steel
COLOR Unpainted steel
FUZE Special
PRESSURE REQUIRED 25 to 75 lbs.

BRITISH MINE

ANTI-TIRE

(ANTI-PERSONNEL)

(SERVICE)

USE: This mine is designed for use by the Airborne Forces. It will be found laid in fields, along the edges of roads, or in other conspicuous places where the foot soldier or light transport is likely to go. The charge is sufficient to blow off a man's foot or rupture the tire of a vehicle. The mine can easily be detected by any type of mine detector.

COMPONENTS: This mine resembles a small round tin box of ointment and consists of two telescoping steel halves. The smaller, bottom, half houses the igniter; the larger, top, half contains the doughnut-shaped explosive charge which is glued to the under side of the top with a sticky adhesive substance.

The fuze consists of the brass cap holder, cap holder sleeve, detonator holder, striker, and striker spring. The cap holder is threaded into the base of the lower portion of the mine body and contains the percussion cap. A brass striker, retained by a shear wire, and a striker spring are located in the cap holder sleeve in the lower half of the mine body. Two diametrically opposed detonators are located in the detonator holder. Two blast holes are drilled in the lower portion of the cap holder sleeve to allow the flash from the percussion cap to contact the two detonators.

FUNCTIONING: When the two halves are compressed the detonator holder slides down over the cap holder sleeve, compressing the striker spring and at the same time forcing the striker through the copper shear wire, which passes through the head of the striker and the walls of the cap holder sleeve. The detonator holder has two diametrically opposed longitudinal grooves, about one third of an inch long, which allow it to slide freely over the cap holder sleeve without interference from the two projecting ends of the shear wire. This also serves to position the detonator holder with reference to the cap holder sleeve, so that the two blast holes in the latter will be adjacent to the two detonators in the former. When the shear wire is sheared, the spring forces the striker against the cap, and the flame escapes outward through the blast holes, exploding the two round detonators and the main charge.

ASSEMBLY & ARMING: Place the detonator holder over the cap holder sleeve and screw the cap into the bottom half of the mine body. Place the top half of the mine over the bottom half, and lay the mine in the ground.

NEUTRALIZATION: Reverse the procedure outlined for assembly and arming, above. This mine has no safety device incorporated in it.

REMARKS: 1. This mine has been discovered frequently in France, and was first reported to be of German origin and labeled the "Ointment Box Mine".

This Page is Blank

SECTION III
BRITISH
FIRING DEVICES

SWITCH NO.1 PULL MK.1

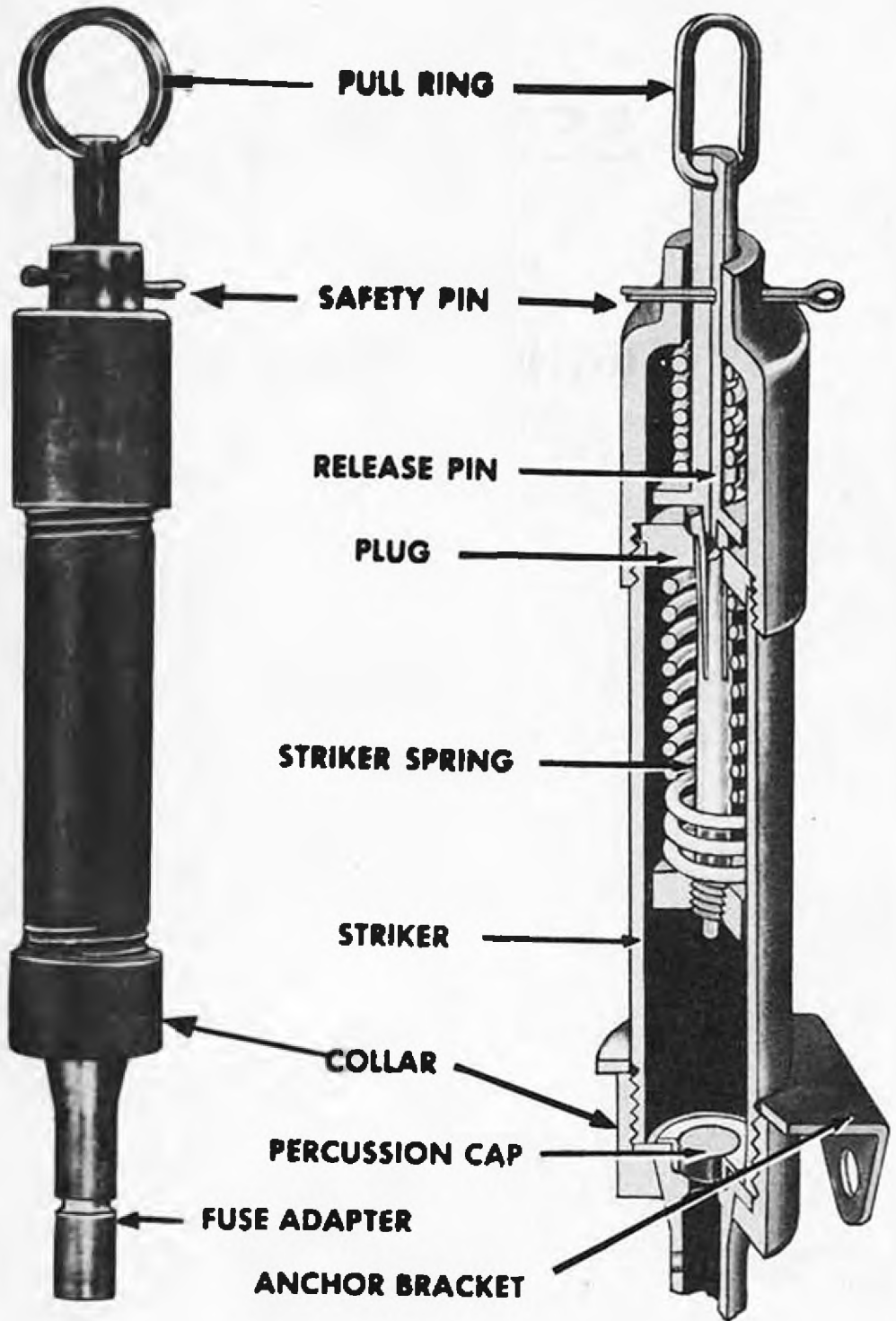

DIAMETER 5/8 in.
 LENGTH 4 in. (with fuse adapter)
 WEIGHT 2-3/4 oz.
 MATERIAL Steel
 PULL REQUIRED 2 lbs.
 COLOR Olive drab.

BRITISH SWITCH

NO. 1 PULL

Mk I

(SERVICE)

USE: This is a pull type firing device used to initiate either booby-trap installations or demolition charges. It is designed to operate when a direct pull is exerted on a trip wire attached to the release pin. It fires a percussion cap in a holder which can be connected either to instantaneous fuse or a No. 8 detonator.

DESCRIPTION: This switch consists of a housing tube containing a release pin, a plug, a split-headed striker, and a striker spring. In the cocked position, the splithead of the striker is spread over the top of the plug by the insertion of the nib on the end of the release pin. The striker is thus held under spring compression.

A safety pin is inserted through the housing tube and the release pin, preventing the latter from being disengaged from the splithead of the striker.

An anchor bracket is slipped over the housing tube to enable the switch to be anchored in any convenient position.

A screwed collar is threaded over the open end of the tube for attachment of the cap holder.

FUNCTIONING: A pull on the trip wire attached to the ring removes the release pin from the splithead of the striker, which then contracts and passes through the opening in the plug. The striker spring then drives the striker into the percussion cap.

INSTALLING & ARMING: Remove the fuse adapter by unscrewing the collar. Anchor the switch by means of the bracket. Replace the collar without the fuse adapter. Install a loose trip wire, and connect the charge to the fuse adapter with detonating cord. Reset the fuse adapter on the switch by means of the collar. Withdraw the safety pin gently. With proper installation, the safety pin should be loose in the safety pin hole.

DISARMING: Insert the safety pin in the safety pin hole. Cut the trip wire and remove the fuse adapter.

REMARKS: 1. To re-use this switch, make the following test: Unscrew collar, and remove the fuse adapter. Hold the switch with open end against a piece of wood. Remove the safety pin and gently pull the release pin. The striker should descend, driving its point well into the wood. To recock, push back the striker with a pencil or other wooden rod until the release pin slips into the splithead of the striker and locks it in place. Reinsert the safety pin.

2. To enable this switch to be used for electric firing when desired, a special electric adapter is supplied. This consists of a small unit made of insulating material and fitted with two contact points, from which are led two lengths of rubber insulated flexible wire. The contact points are enclosed by a copper cap which is spun in position on the insulating body, and therefore cannot be removed. The unit replaces the percussion cap in its holder. When the striker operates, instead of piercing the percussion cap, it drives down the center portion of the copper cap so that the two enclosed contacts are short-circuited.

Visual inspection will indicate whether the copper cap has suffered accidental damage. If it is dented at all the adapter should be discarded. An electric test can easily be made by connecting the adapter in series with a battery and flashlight bulb. The bulb, of course, should not light up.

To fit an electric adapter, remove the collar from the end of the switch. Remove the percussion cap holder and insert the copper-capped end of the unit inside the tube. The collar may now be threaded on the wire leads and replaced.

The adapter must be wired in series with a battery and an electric detonator. Final connection should not be made until the switch has been installed.

SWITCH NO. 2 PRESSURE MK. I

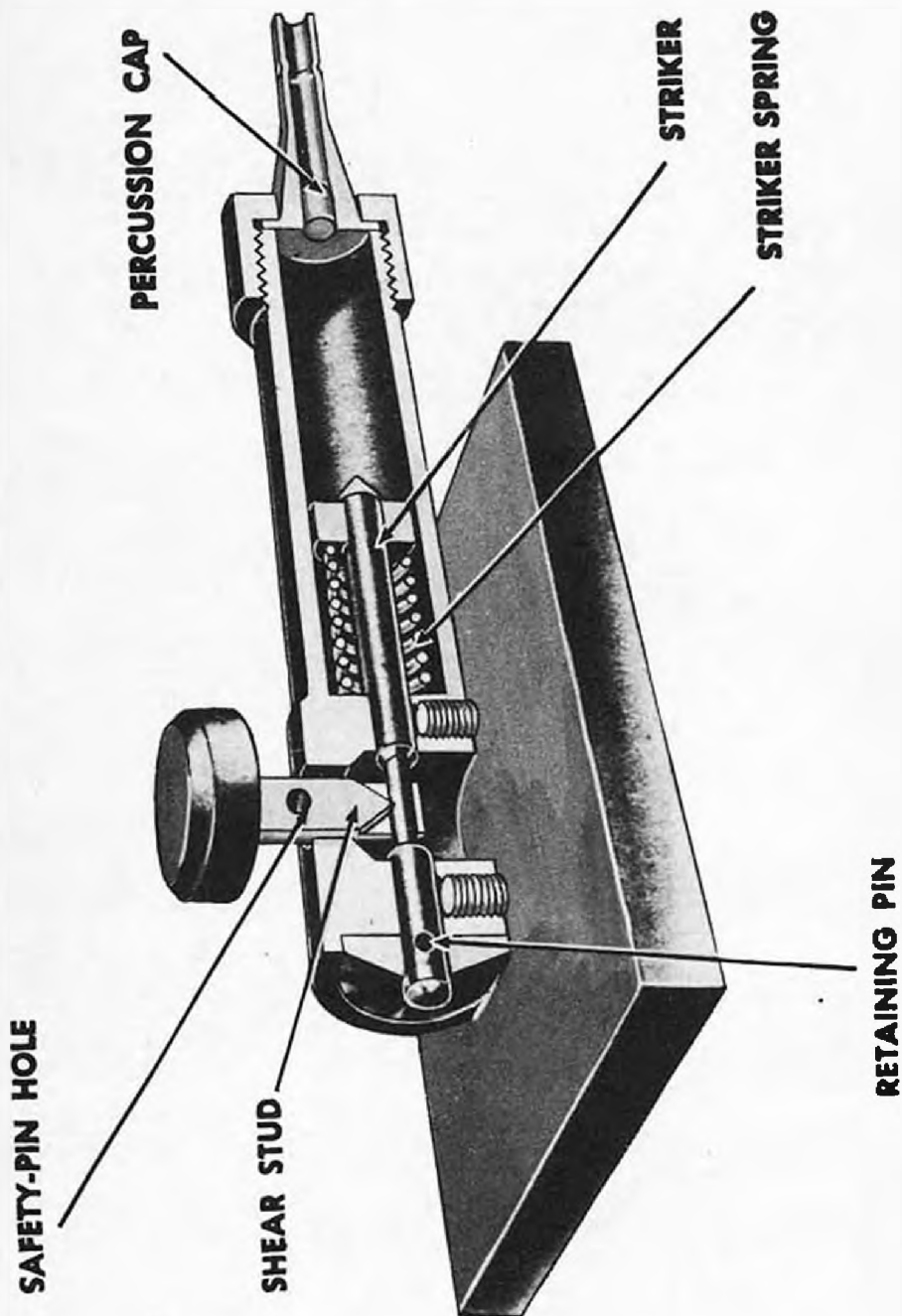

WIDTH 1-1/2 in.
 HEIGHT 1-1/8 in. (armed)
 LENGTH 4-5/8 in. (with fuse
 adapter)
 WEIGHT 8 oz.
 MATERIAL Brass
 PRESSURE REQUIRED 30 - 40 lbs.
 COLOR Olive drab.

BRITISH SWITCH

NO. 2 PRESSURE

Mk I

(SERVICE)

(For Mk II, see REMARKS below)

USE: This switch is used under boards, door-mats, etc., in booby trap installations where initiation by pressure is desired. The switch may also be used to initiate demolition charges.

DESCRIPTION: The switch consists of a housing tube mounted on a rectangular base plate. Inside the housing tube is located a spring-loaded striker, one end of which passes through the head of the housing tube and is secured by a transverse pin recessed into the end of the head. An annular groove in this striker is straddled by the milled out end of a shearing stud which is inserted through a hole in the top of the housing tube and engages the striker with a chisel edge. A flat disc-shaped pressure head is located on top of the shearing stud. A threaded collar is screwed over the open end of the housing tube for attachment of the cap holder.

A safety pin may be inserted through the shearing stud above the housing tube, preventing the shearing stud from being forced downward.

FUNCTIONING: Pressure on top of the pressure head will cause the V-shaped cutting edge of the shear stud to break the striker spindle. The striker, driven forward by the spring, fires the percussion cap.

INSTALLING & ARMING: Remove the pressure cap from the base plate, to which it is attached during transport. Insert the pressure cap through the hole in the top of the housing tube, and position it to straddle the striker. If properly placed, the pressure cap cannot be rotated. Make certain safety pin is securely in position. Unscrew the collar and remove the fuse adapter. Place the switch in position. Connect charge to the fuse adapter with instantaneous fuse. Reattach the collar and the fuse adapter, and gently remove the safety pin. If desired, a No. 8 detonator can be slipped directly into the fuse adapter, and connection made to the charge with Cordtex.

DISARMING: Insert a safety pin in the safety pin hole in the pressure cap. Lift the pressure cap out of the housing tube. Cut the length of fuse connecting the switch to the charge. Remove the fuse adapter.

REMARKS: 1. To test this switch prior to re-use, remove the fuse adapter and make certain that the striker is in the cocked position. If the striker spindle has been sheared, the striker will fall out of the housing tube, and the switch cannot be re-used.

2. A special electric adapter (See page 45) is supplied to enable this switch to be used for electric firing, if so desired.

3. No. 2 Pressure Mk II: The Mk II switch is almost identical with the Mk I, the principal difference being the fact that the base plate and housing tube are cast in one piece in the Mk II, while in the Mk I they are fastened together with two screws. Also in the Mk II, the hole in the housing tube for the insertion of the pressure cap is surrounded by a raised collar which contains a rubber washer. The safety pin pierces not only the shearing stud, but the collar and washer as well. The Mk II is issued with the pressure cap in place in the housing tube, rather than secured to the base plate. The alterations incorporated in the Mk II were designed to increase the weather resistance of the switch.

SWITCH NO. 3 RELEASE MK. I

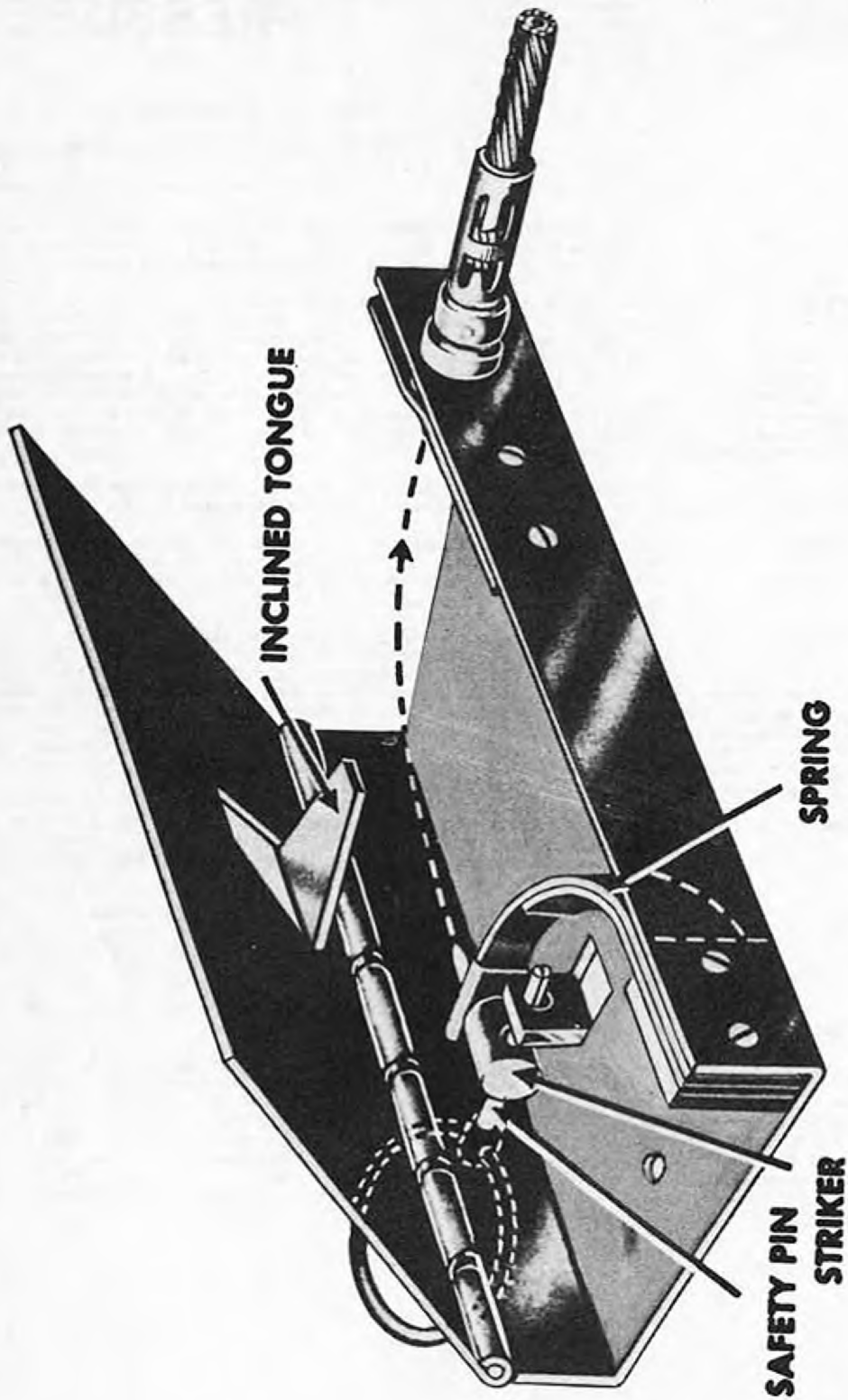

WIDTH 2 in. (w/o fuse adapter)
 HEIGHT 5/8 in.
 LENGTH 3 in.
 WEIGHT 4-3/4 oz.
 MATERIAL Sheet steel.
 MIN. SAFE LOAD 1-1/2 lbs.
 COLOR Olive drab.

BRITISH SWITCH

NO. 3 RELEASE

Mk I

(SERVICE)

USE: This switch may be placed under crates, packages, books, or other suitable objects in booby trap installations where initiation by release of pressure is desired. Though rarely used as such, this switch may be employed to initiate demolition charges.

DESCRIPTION: The body of the switch consists of a shallow channel section with open ends and a hinged cover provided with an inclined tongue. Into one side of the body is clipped the fuse adapter, complete with percussion cap, by means of a metal leaf. A two-leaf steel spring is attached at one end to the same upright side as the fuse adapter. A striker is fixed to the other end of the spring. A brass block, with a hole bored in its center, is fixed to the bottom of the switch body. A safety pin hole is drilled in the side of the switch body opposite that to which the striker spring and fuse adapter are attached.

FUNCTIONING: When pressure is removed from the hinged lid of the switch, the pressure of the spring on the inclined tongue forces the lid upwards. The spring and the striker are then released, and the striker is driven into the percussion cap.

INSTALLING & ARMING: Bend the leaf spring back until the hole in the striker comes opposite the safety pin hole in the switch body. Insert safety pin through switch body, striker, and brass block. Insert the fuse adapter in the hole in the side of the switch body. Close the lid. Place the switch under concealing object so that the lid is held tightly closed. Connect the fuse adapter to the charge with safety fuse. Withdraw the safety pin. If sufficient weight has been placed on the lid of the switch, the safety pin will come away easily. On no account should the pin be withdrawn from the switch with the charge connected, if the pin is at all tight.

DISARMING: If the device is accessible, insert a safety pin in the safety pin hole, cut safety fuse, and remove the device and the charge. If the device is inaccessible, cutting the safety fuse between the switch and the charge will have to suffice.

REMARKS: 1. Test this device for re-use by cocking the switch and slowly releasing pressure on the lid. After testing, recock. The striker may require readjustment following test firing.

SWITCH NO. 4 PULL MK. I

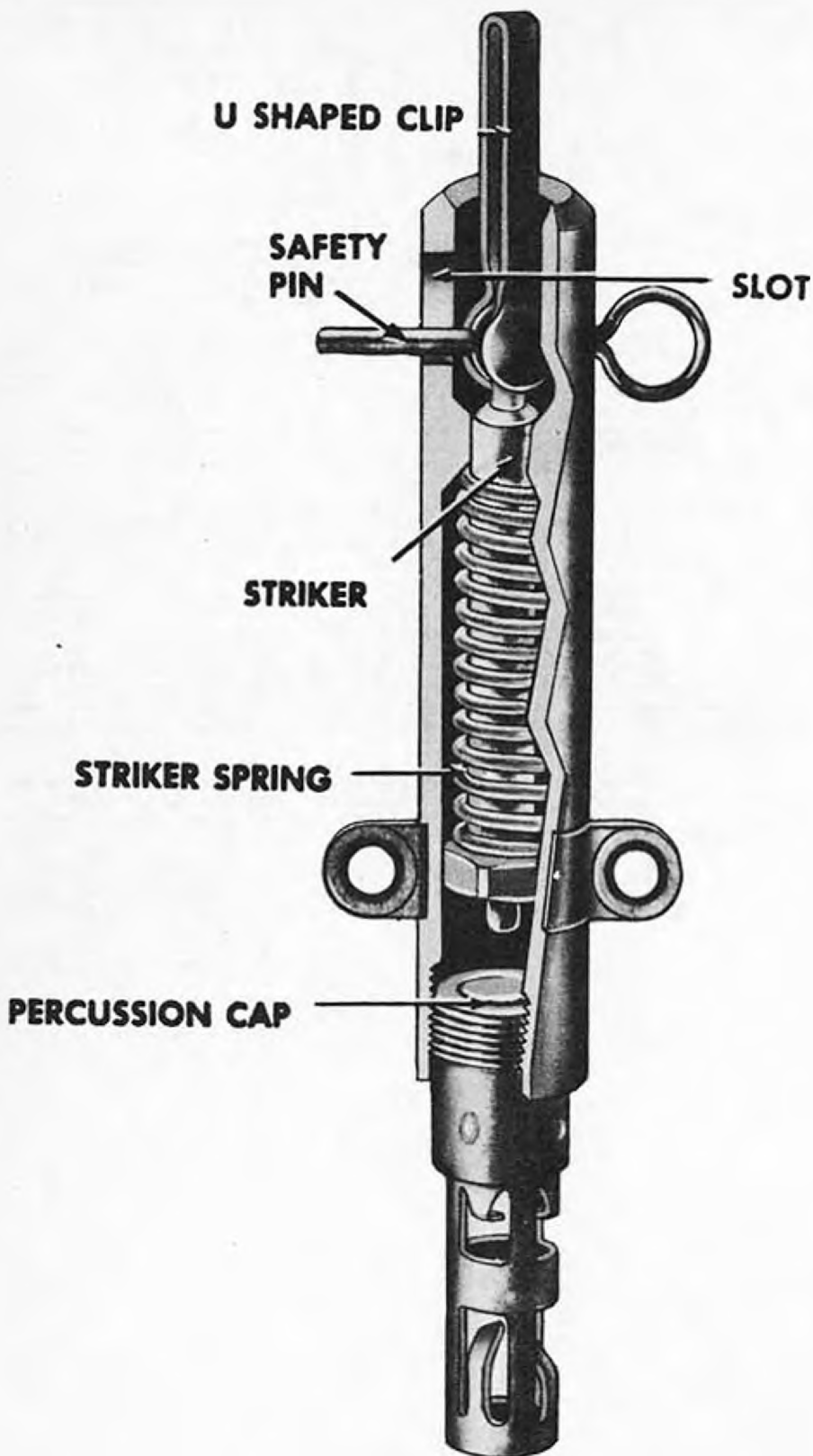

DIAMETER 7/16 in.
 LENGTH 3-3/4 in.
 WEIGHT 1-1/4 oz.
 MATERIAL Brass
 PULL REQUIRED 6 - 8 lbs.
 COLOR Khaki

BRITISH SWITCH

NO. 4 PULL

Mk I

(SERVICE)

USE: This device is intended primarily for use with a trip wire to fire booby trap installations. It may also be used to fire mines, flares and demolition charges.

DESCRIPTION: This device consists of a housing tube with two mounting eyes attached externally to assist in attaching the mechanism to any convenient object. The housing tube has an adapter screwed into one end, and contains a spring loaded striker. A U-shaped clip which grips the rounded end of the striker assembly holds the striker in the cocked position. A safety pin passes through the housing tube and the rounded head of the striker.

FUNCTIONING: A pull on the trip wire attached to the U-shaped clip will withdraw the clip and release the striker, which will then be forced by its spring into the percussion cap.

INSTALLING & ARMING: To install this switch, unscrew the fuse adapter. Attach the switch to any desired object, and attach a trip wire to the U-shaped clip. Adjust the tension of the trip wire until the safety pin lies about half way along the slots in the body. Connect the charge to the fuse adapter with safety fuse, and screw the adapter into the end of the switch. Withdraw the safety pin. If there is too much tension on the trip wire, the safety pin will jam against the ends of the slots and prevent easy withdrawal.

DISARMING: If the switch is accessible, insert the safety pin through the slot in the body and through the safety pin hole in the ball end of the striker. Check both ends of the trip wire, then cut the trip wire. Cut safety fuse leading to charge, then remove fuse adapter from switch. Remove switch and charge.

If the switch is inaccessible, cutting the connecting safety fuse will suffice.

REMARKS: 1. To reset this switch, unscrew the fuse adapter, and push back striker with a pencil as far as it will go. Use the safety pin to twist the striker around until the safety pin hole is in line with the two slots in the body. Fit the U-shaped clip over the ball end of the striker, and allow the striker to move forward about 1/4 inch. Insert the safety pin. Screw in a new fuse adapter with percussion cap.

2. This switch is used only for special operations and for preparatory training in these operations.

SWITCH NO. 5 PRESSURE MK. I

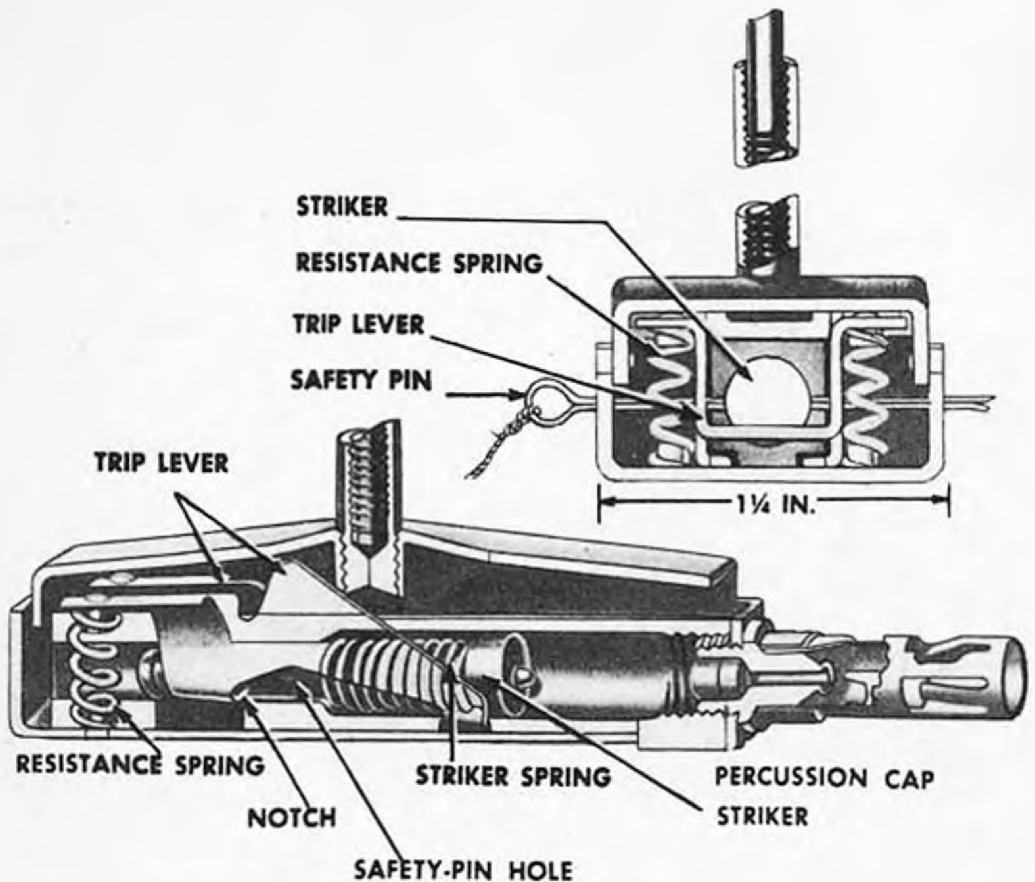
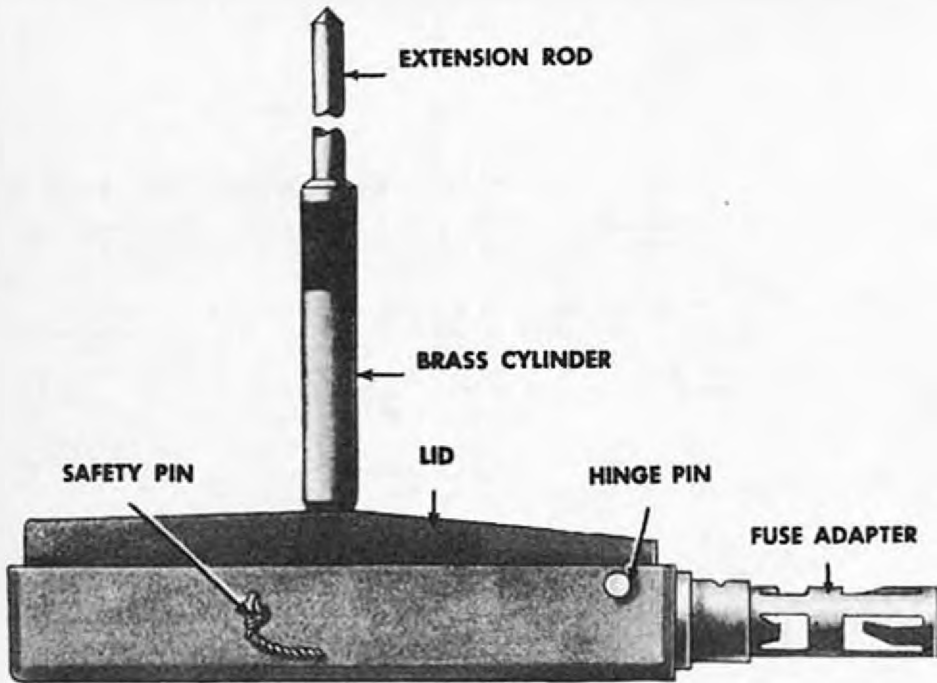

SWITCH NO. 6 RELEASE MK.I

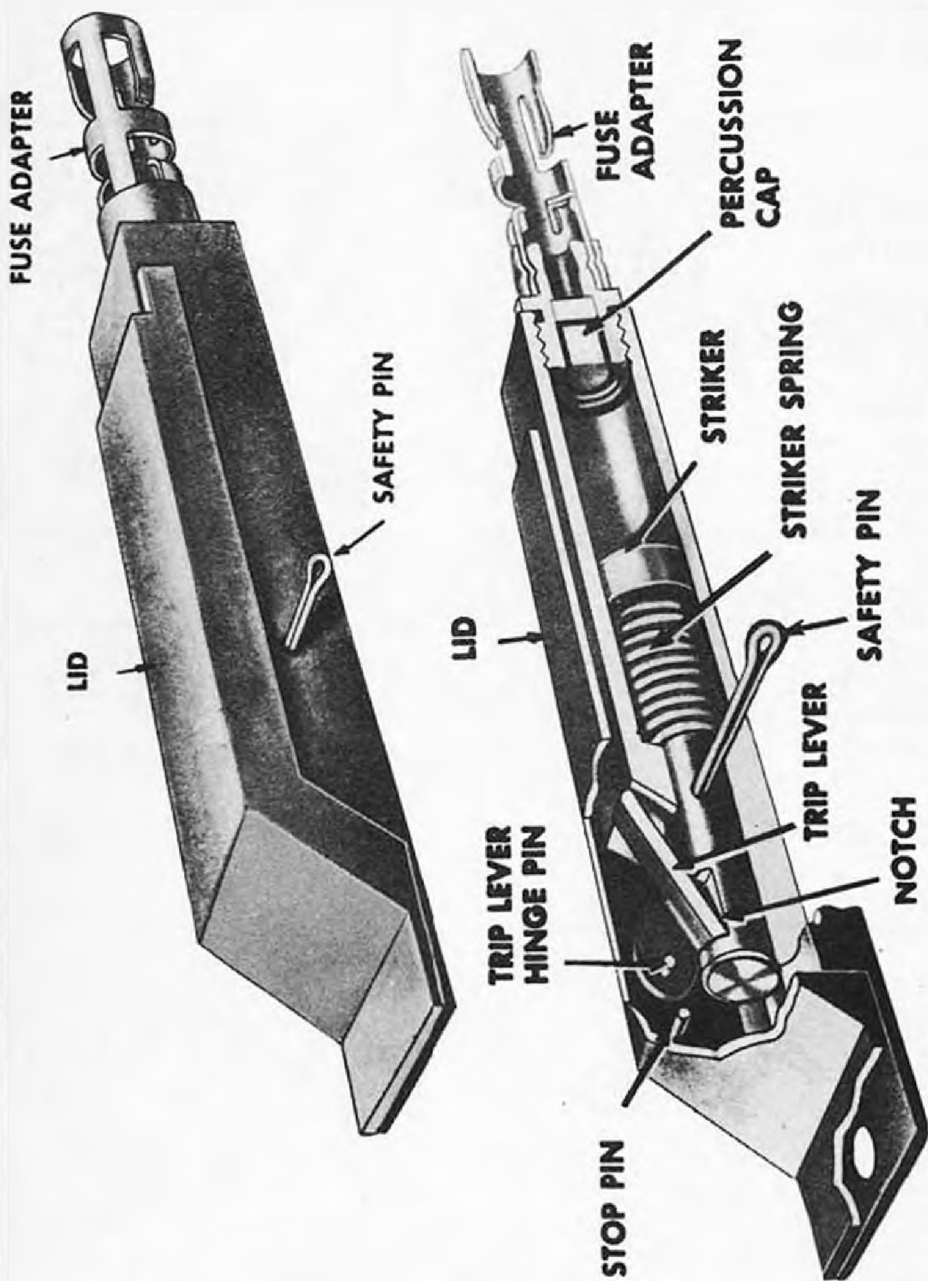

WIDTH 9/16 in.
 HEIGHT 3/4 in.
 LENGTH 4-1/2 in. (with adapter)
 WEIGHT 3-1/2 oz.
 MATERIAL Alloy metal
 MIN. SAFE LOAD 6 lbs.
 COLOR Matt khaki

BRITISH SWITCH

NO. 6 RELEASE

Mk. I

(SERVICE)

USE: This switch is designed for booby trap installations where initiation by release of pressure is desired. Its design allows it to be inserted into narrow openings, as under a door, behind a drawer, etc. It is designed to withstand the weight of heavy objects, such as packing cases, etc.

DESCRIPTION: This switch consists of a body, over which is fitted a lid, hinged at one end. In the body is located a spring-loaded striker held in position by a safety pin inserted through the sides of the body and through the striker. In addition, when the lid is seated firmly down on the body, a trip lever hinged in the sides of the body engages a notch in the striker and holds the striker back against its spring. A stop pin limits the movement of the trip lever in an upward direction. The body is threaded internally at the open end to receive a standard fuse adapter.

FUNCTIONING: When the restraining load on the lid is removed, the pressure of the trip lever forces the lid up. The trip lever is then allowed to swing in a counter-clockwise direction and becomes disengaged from the notch in the striker. The striker spring then forces the striker into the percussion cap.

INSTALLING & ARMING: Insert necessary length of safety fuse in fuse adapter. Install the switch in the desired position, then connect the other end of the safety fuse to the explosive charge. Withdraw the safety pin, which should come away easily, since the trip lever has forced back the striker and unlocked the safety pin. If the safety pin does not withdraw freely, then the weight on the switch lid is insufficient and should be increased. Do not attempt to force out a safety pin which seems to "stick".

DISARMING: If the device is accessible, insert a safety pin in the safety pin hole, cut the safety fuse connecting the switch to the explosive charge, and remove the fuse adapter. If the switch is inaccessible, cutting the safety fuse will have to suffice.

REMARKS: 1. To reset this switch, unscrew the fuse adapter and withdraw the striker and spring. Throw the trip lever over until it rests on the stop pin. Insert the spring and the striker, the notch on the striker uppermost. Force back the striker with a pencil or rod, and insert the safety pin. Throw the trip lever forward, and close the lid. Screw in a new fuse adapter with percussion cap.

2. This switch is used only for special operations and for preparatory training in these operations.

SWITCH NO. 7 PRESS-PULL MK. I

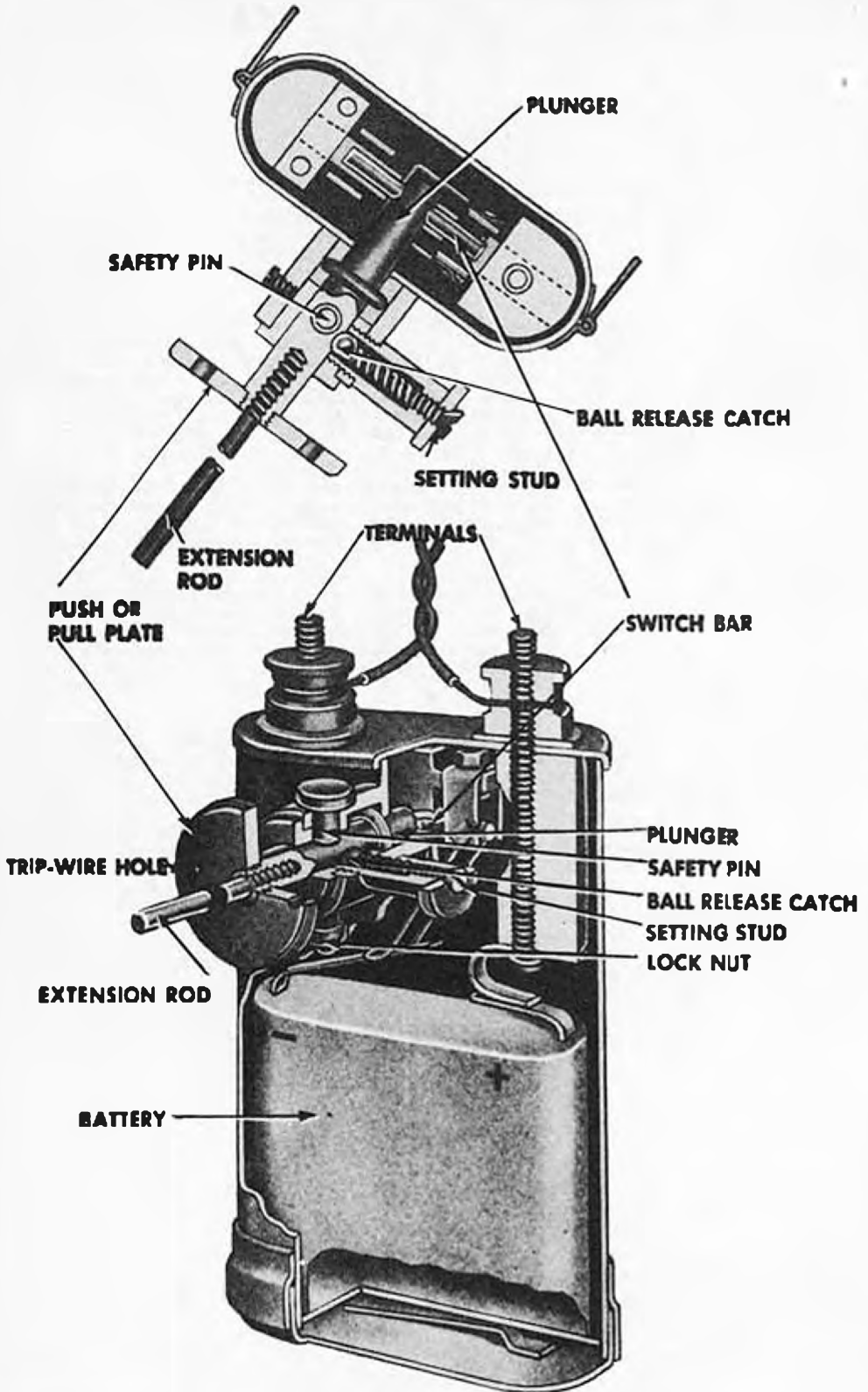

WIDTH 2.6"
 HEIGHT 0.98"
 LENGTH 4.0"
 WEIGHT 8 oz.
 MATERIAL Tin
 PULL OR PRESSURE
 REQUIRED 5 - 35 lbs. (Depending on
 setting).
 COLOR Olive drab

BRITISH SWITCH

NO. 7 PRESS-PULL

Mk I

(SERVICE)

- USE:** This switch is designed for booby trap installations where initiation either by pull or by pressure is desired.
- DESCRIPTION:** The switch consists of a tin case with a bottom cap and spring to hold either a service "Battery, Dry, W, Mk I" or a standard 3-cell flat torch battery. The case is fitted internally with operating mechanism and externally on the top with two terminals for connection to the electric firing cable. The push or pull mechanism on the side of the case consists of a plunger fitted externally with a push or pull plate, and internally with a switch bar which completes the circuit when the plunger is either pushed or pulled. Two holes are drilled in the push or pull plate for the attachment of trip wire, and the plate is threaded centrally for the insertion of an extension spindle.
- The actuating tension or pressure is determined by the tension of the spring in the ball release catch, which is located on the side of the plunger housing. The tension of the spring is adjusted by the setting stud. The lightest actuating tension is about five lbs., and can be increased to any desired amount by screwing in the setting stud.
- A safety pin, with lock nut, prevents the plunger from being pulled or depressed inadvertently, and it cannot be withdrawn unless the plunger is in the dead neutral position and held so by the ball release catch.
- FUNCTIONING:** With the safety pin removed, necessary pull or pressure on plate overcomes the pressure of the ball release catch, and the switch bar completes the circuit and fires the electric detonator to which the leads are attached.
- INSTALLING & ARMING:** Place the mechanism either for pressure or trip wire use, then adjust the actuating pressure as required. Connect the firing leads to the terminals on the top of the case, then withdraw the safety pin.
- DISARMING:** Remove leads from the battery terminals. Replace safety pin and remove switch and charge.
- REMARKS:**
1. To test this switch for re-use, connect to an electric detonator of the type to be used. Withdraw safety pin, and push or pull plunger which should fire the detonator.
 2. In December, 1943, the following instructions were issued by the Chief Engineer, Allied Force Headquarters:
 "This switch (No. 7) is defective, and if in possession of units will be destroyed."

SWITCH NO.8 A/P MK.I

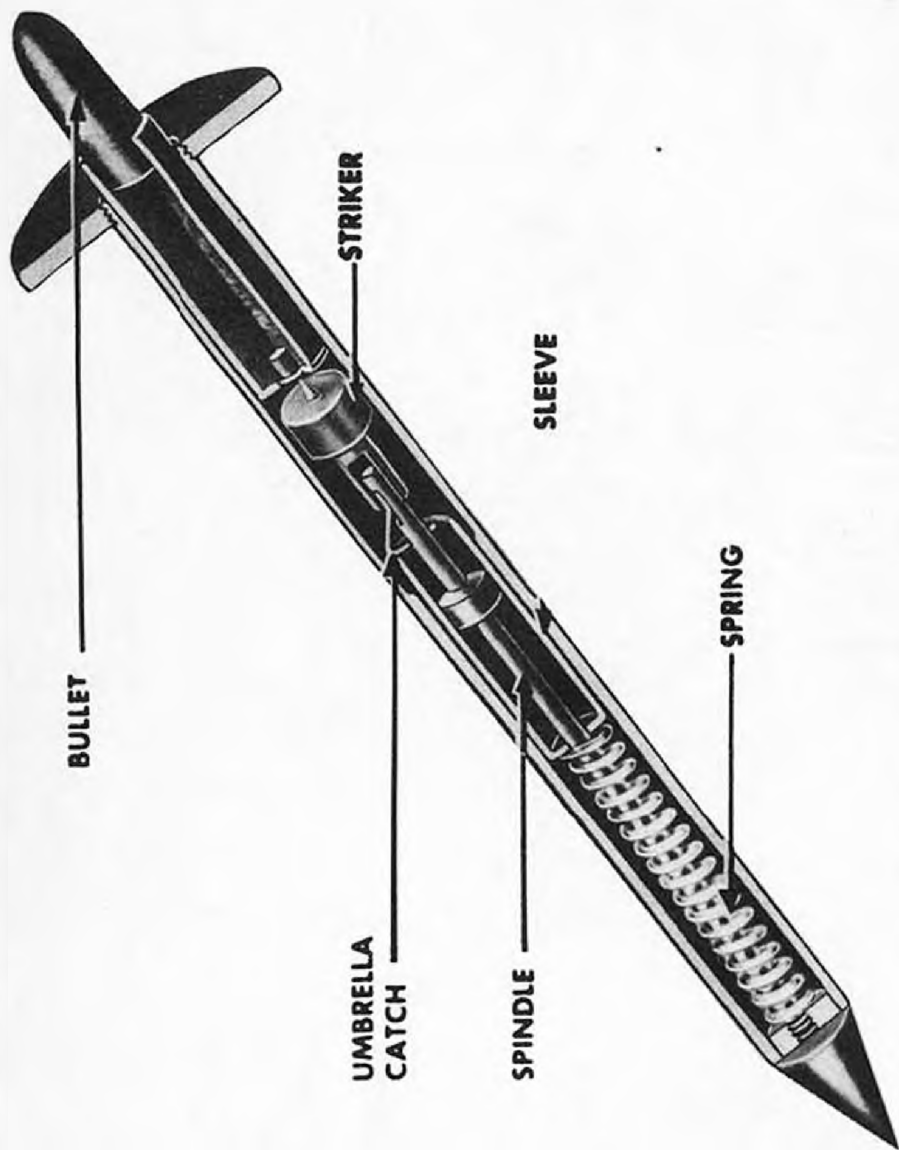

DIAMETER Body: 1/2 in.
 Top Plate: 1-1/2 in.
 LENGTH 5-3/4 in.
 TOTAL WEIGHT 4 oz.
 MATERIAL Steel
 PRESSURE REQUIRED Approx. 10 lbs.
 COLOR Black, olive drab, or un-
 painted steel.
 EXPLOSIVE303 cartridge

BRITISH SWITCH

NO. 8 A/P

Mk I

(SERVICE)

USE: This self-contained unit, which discharges a bullet, is sunk into roads and pathways. Fired by pressure, the bullet will perforate a man's foot or severely damage a pneumatic tire.

DESCRIPTION: This switch consists of a hollow metal spike, flanged at the open end, which can be pressed into the ground or hammered with care into a road. Inside the spike is placed the firing assembly, consisting of a metal spindle, flanged at the base and with an umbrella catch located near the top. A spring and spring retaining sleeve are threaded over the spindle and held compressed by the umbrella catch. Over the top of the spindle is placed a striker with a hollow shaft, and on top of this is placed a rimless .303 cartridge, with a bullet which just protrudes out of the spike.

FUNCTIONING: Slight pressure on top of the bullet forces the hollow shaft of the striker over the umbrella catch, releasing the sleeve which holds the spring in compression. The spring drives the sleeve upwards against the striker head, forcing the striker into the base of the cartridge and firing the cartridge.

INSTALLING & ARMING: This assembly usually is issued cocked ready for use, being held in position in the spike by a cork. If it is necessary to cock the switch, first push the empty barrel into the ground to the level of the flange. Place the spring retaining sleeve, rounded end down, over spring, and push down until the catch engages over the top of the sleeve. Place the cocked mechanism in the barrel of the switch, and lower the striker into the barrel. At arm's length, lower the cartridge gently into the barrel point upward. Hold the cartridge between the fingers; then in case of a premature firing a finger will not be blown off.

DISARMING: Carefully remove the cartridge from the pistol, at arm's length, and held between the fingers.

REMARKS:

1. Test this switch by cocking the mechanism and inserting the striker. Depressing the striker with the blunt end of a pencil will compress the catch and release the spring retaining sleeve. The impact can be felt in the pencil. Never use the cartridge for testing.
2. Never place the cartridge in the spike except when laid.

SWITCH NO.9 "L" DELAY MK. I

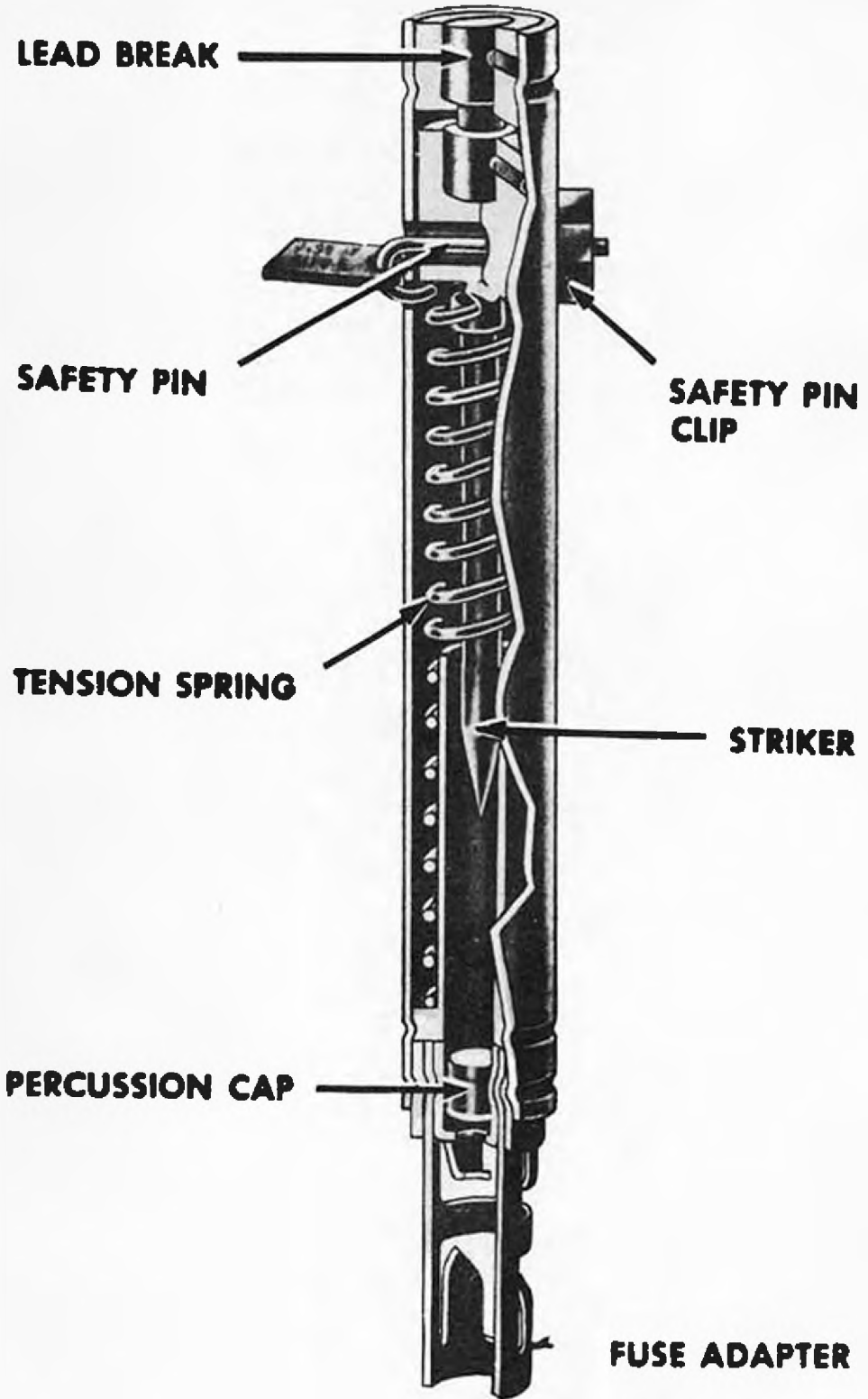

DIAMETER 3/8 in.
 LENGTH 4-3/8 in.
 WEIGHT 1 oz.
 MATERIAL Alloy metal.
 COLOR Aluminum

BRITISH SWITCH

NO. 9
 "L" DELAY

Mk I

(SERVICE)

USE: This device is designed to explode a demolition charge by delayed action.

DESCRIPTION: The operation of this time switch relies on the fact that Tellurium lead stretches uniformly with time and will eventually break.

The switch consists of a tubular metal body, housing a striker, spring and lead break assembly. The lead break consists of a short lead rod grooved in the center to form a neck of reduced diameter. The upper end of the rod is pegged into a brass collar which is crimped into the top of the housing tube. The head of the striker also consists of a brass collar, and into this collar the lower end of the rod is pegged. The striker collar is an easy sliding fit in the housing tube. The lower end of the tension spring is anchored to the base of the housing tube, while the upper end is hooked over a slot in the upper end of the striker. An adapter with a percussion cap is crimped into the base of the switch.

A safety pin, complete with retaining clip and label showing the delay time in days or hours, is provided to retain the striker against the tension spring.

FUNCTIONING: When the safety pin is removed, the tension in the spring is taken by the lead break. The lead break stretches and eventually breaks, allowing the striker to be pulled down by the spring into the percussion cap.

INSTALLING & ARMING: Refer to the temperature correction table included with each box of switches, and select the proper switch. Withdraw the safety pin, and connect the switch to the explosive charge. The safety pin is of the self-locking variety, and should come away easily. If the safety pin is locked in place or difficult to remove, the switch should be discarded. The device is in operation as soon as the safety pin is withdrawn.

The switch may be connected to the explosive charge either with fuse or with a detonator and Cordtex. A service detonator may be crimped directly over the fuse adapter of the switch. If instantaneous or safety fuse is used, however, an adapter sleeve must first be crimped over the fuse adapter of the switch and the fuse then crimped into the adapter sleeve.

DISARMING: This switch is impossible to disarm, nor can the explosive charge to which the switch is connected be defuzed safely. If necessary to defuze, cut the detonating cord or fuse connecting the switch to the explosive charge, or disconnect the switch from the charge.

REMARKS:

- Two switches should be used for each important charge to guard against risk of failure.
- These switches are issued with ten different delay times, set during manufacture. The delay time at 65° P. is indicated on the tab attached to the safety pin. The timing of these delays varies considerably with changes in temperature. A temperature correction table is included with each box of switches. To select the proper switch, choose the nearest timing on the temperature line to the one decided upon, and then find in that column the underlined figure. This figure gives the labelling of the delay which should be used. The degree of accuracy of the timing is stated at plus or minus 30 percent. However, better performance is usually obtained, especially for timings greater than 24 hours.

DEGREES P.	HOURS					DAYS			
35	3	16	32	64	8	19	38	75	
45	2	11	23	46	6	13	27	54	
55	1½	8	17	33	4	10	19	39	
65	1	6	12	24	3	7	14	28	
75	<u>¾</u>	4	8	17	2	5	10	20	
85	½	3	6	12	1½	4	7	14	
95	¼	2	4½	8	1	2½	5	10	
105	¼	1½	3	6	¾	2	4	7	

SWITCH NO.10 TIME PENCIL MK.1

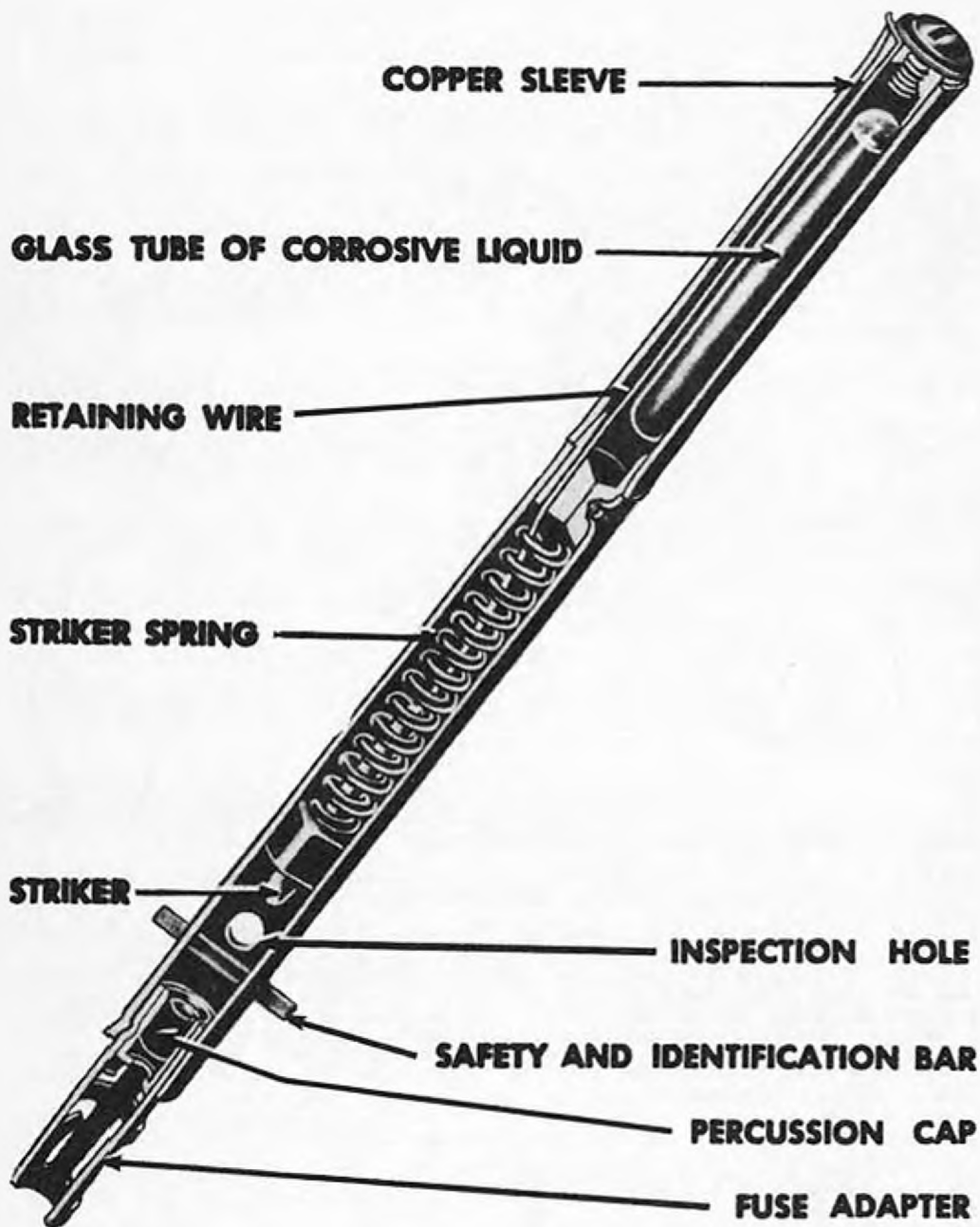

DIAMETER 5/16 in.
 LENGTH 5 in.
 WEIGHT 1-1/2 oz.
 MATERIAL Aluminum and copper
 COLOR Unpainted.

BRITISH SWITCH

NO. 10 TIME PENCIL

Mr I

(SERVICE)

USE: This device is designed to explode a demolition charge by delayed action.

DESCRIPTION: This switch consists essentially of a housing tube made up of two parts, a thin copper sleeve containing a glass vial of corrosive liquid, and a thin aluminum sleeve, housing a spring loaded striker retained by a retaining wire. This retaining wire is attached to the upper end of the striker and fastened to the top of the copper sleeve. A fuse adapter and percussion cap are crimped into the base of the switch, and a safety bar pierces the housing tube between the striker and the percussion cap. Inspection holes are provided just above the holes for the safety bar.

FUNCTIONING: When the copper sleeve is crimped and the glass vial broken, the corrosive liquid is allowed to attack the retaining wire. When this wire is eaten through, the striker spring drives the striker into the percussion cap.

INSTALLING & ARMING: Refer to the table included with each box of switches, and select the proper delay. Look through, or pass a nail through the inspection holes to see that the striker has not fallen and is not resting on the safety bar. Connect the explosive charge to the fuse adapter. A service detonator may be crimped directly over the adapter, or instantaneous or safety fuse may be used by crimping an adapter sleeve over fuse adapter and crimping fuse in sleeve. Crimp the copper sleeve flat, without bending or fracturing the sleeve. Withdraw the safety strip. Do not leave safety strip behind, as its color will indicate to the enemy the delay time of the switch. Always use two switches for each important charge, to guard against risk of failure.

DISARMING: This switch cannot be disarmed safely. If it is essential to disarm, insert the safety bar or a nail through the inspection holes, or cut the fuse connecting the switch to the explosive charge. After inserting the safety bar, remove the switch from the charge.

REMARKS: 1. If you can see through the inspection holes or insert a nail through them, the striker is cocked. If the sleeve has been crimped, discard the switch. If the sleeve is intact, unscrew the cap to see whether the glass vial is intact. If so, the switch may be re-used.

2. The times of delay are indicated by the colors of the safety bars. The following table, subject to 25% variation either way, shows the variation of the delay times with the temperature:

<u>DEGREES C.</u>	<u>RED</u>	<u>WHITE</u>	<u>GREEN</u>	<u>YELLOW</u>	<u>BLUE</u>	<u>DEGREES F.</u>
-20	75 min.	19 hr.	31 days	10 days	--	-4
-10	63 min.	15 hr.	2½ days	8 days	--	14
0	43 min.	6 hr.	16 hr.	26 hr.	--	32
10	31 min.	2-3/4 hr.	8 hr.	18 hr.	34 hr.	50
15	27 min.	2 hr.	5-3/4 hr.	12 hr.	24 hr.	59
20	23 min.	1½ hr.	4 hr.	9 hr.	20 hr.	68
25	19 min.	1¼ hr.	3 hr.	6 hr.	15 hr.	77
37½	12½ min.	3/4 hr.	1½ hr.	3 hr.	6 hr.	99½
45	9½ min.	34 min.	80 min.	2 hr.	5 hr.	109½

Do not use the switch with the blue delay if the temperature is likely to be below freezing when the explosion is due to occur. A switch with a black safety bar, with a ten-minute delay, is issued for training purposes only.

3. In the original pattern (SR1E), which is now obsolete, the delay time is shown by means of colored stripes painted around the body of the switch.

4. This device is issued only for special operations and for preparatory training for these operations.

SWITCH NO. 11 CONTACT STRIP MK. I

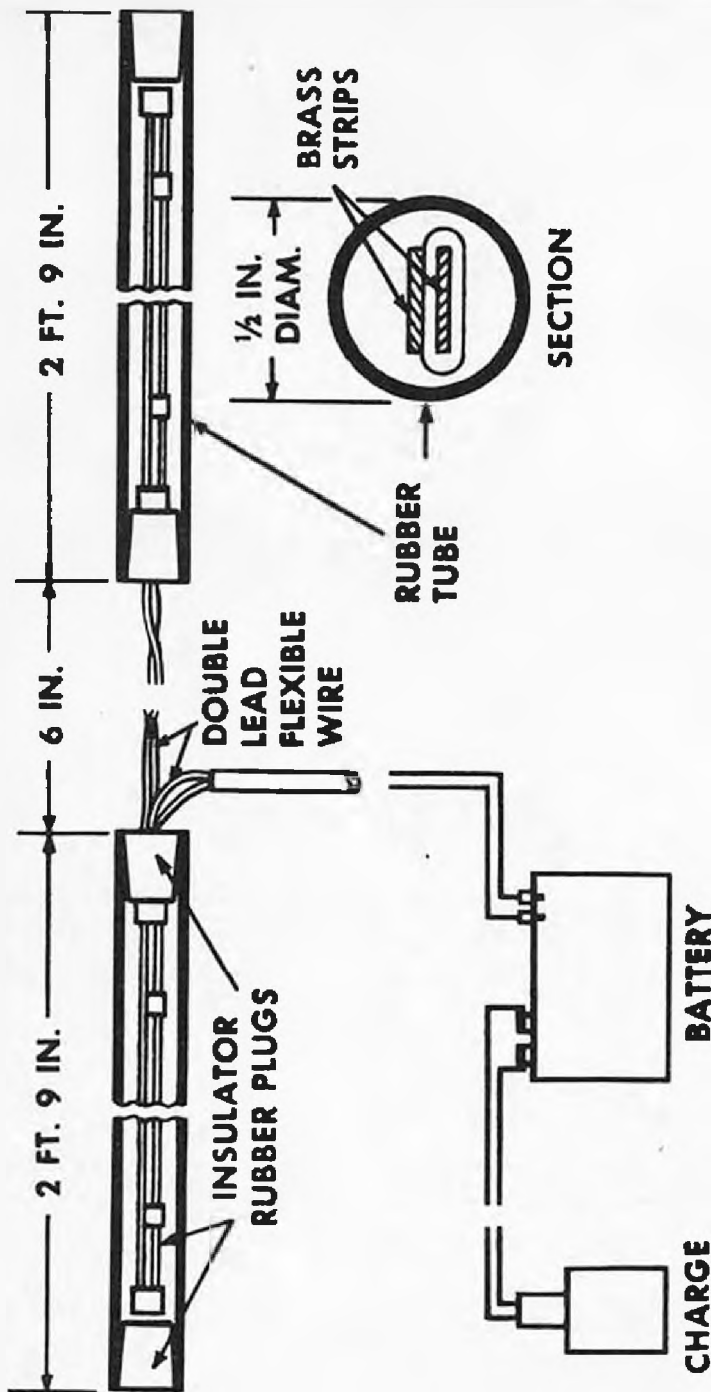

DIAMETER 3/8 in.
 LENGTH 6 ft
 WEIGHT 5 lbs. (with battery)
 MATERIAL Rubber tube
 COLOR Red

BRITISH SWITCH

NO. 11 CONTACT STRIP

Mk. I
(SERVICE)

- USE:** This switch is employed in a specialized form of trap designed to destroy wheeled or track vehicles. It is laid across a road surface in the probable path of enemy approach.
- DESCRIPTION:** The device consists of two arms, each 2' 9" long, connected together by 6" of double lead flexible wire, and having another double lead of flexible wire provided with plugs to fit into the battery supplied. Each arm contains two brass strips held apart by insulating spacers every 6 inches. The strips are enclosed in red rubber tubing, the ends of which are closed with water-proof rubber plugs. Supplied with each set is a 9-volt dry cell battery, fitted with two sockets to receive the contact strip plugs, and with two screw terminals, to which are attached the leads to the detonator and main charge.
- FUNCTIONING:** The passage of a vehicle over either arm forces the brass strips into contact with each other, completing the electric circuit. The battery sets off the electric detonator, firing the explosive charge.
- INSTALLING & ARMING:** Before connecting the battery to the charge, test the contact strips with an electric blasting cap to make certain that the brass strips are not in contact, that pressure produces the proper contact, and that contact is not maintained after the pressure ceases.
- DISARMING:** Disconnect the detonator leads from the battery.
- REMARKS:** 1. Because of the red covering of the contact strips, each arm should be painted, sprinkled with earth, or covered with grass, etc., to conceal it. It must not, however, be buried.

SWITCH COMBINATION (AUST.) MK. I

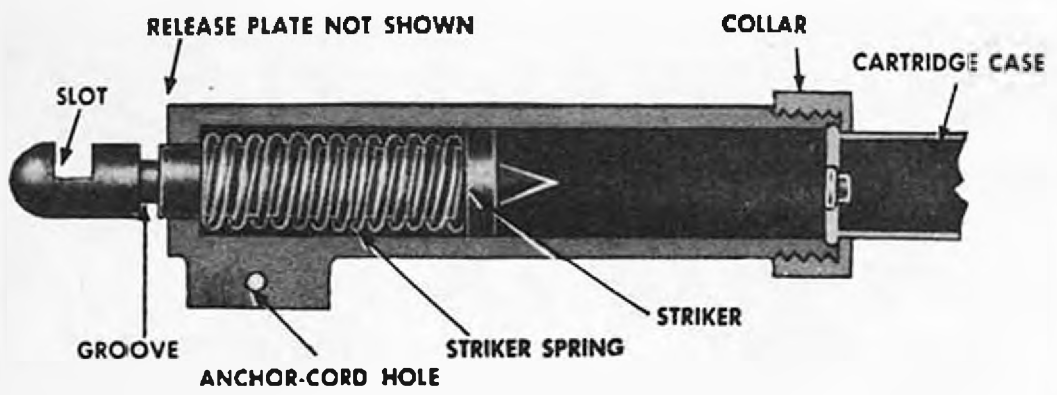
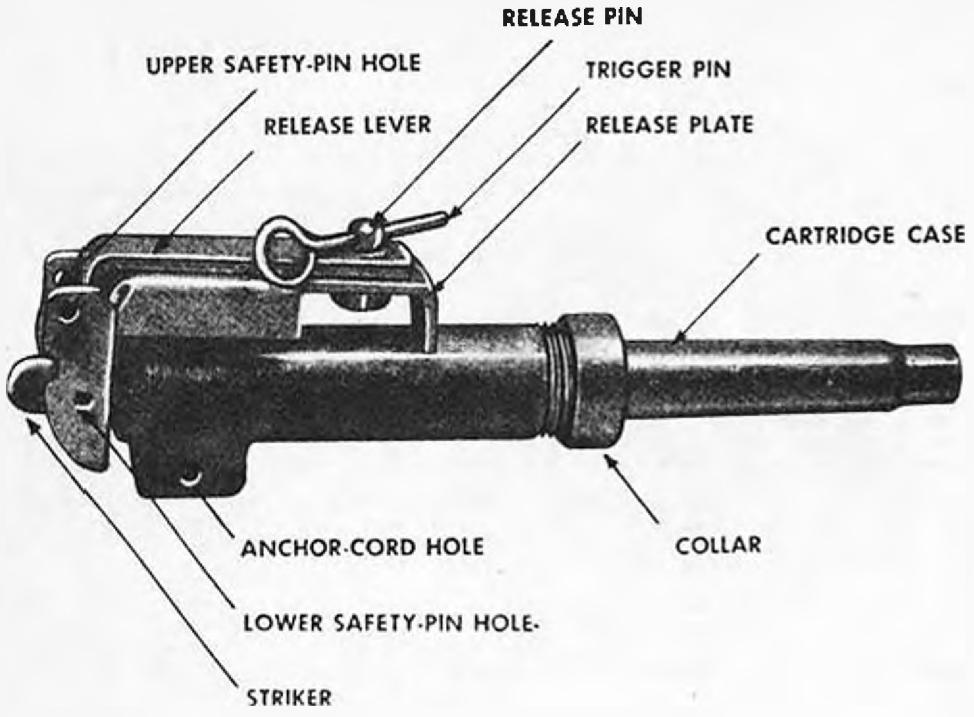

SWITCH COMBINATION (AUST) MK. I

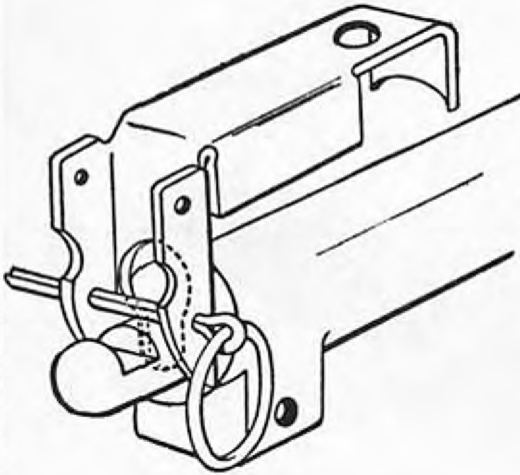
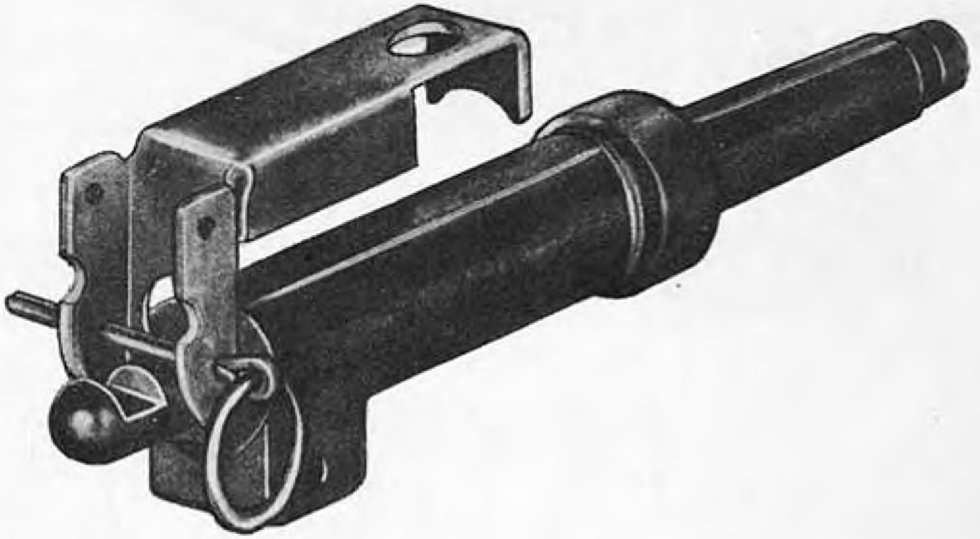

BEFORE FIRING

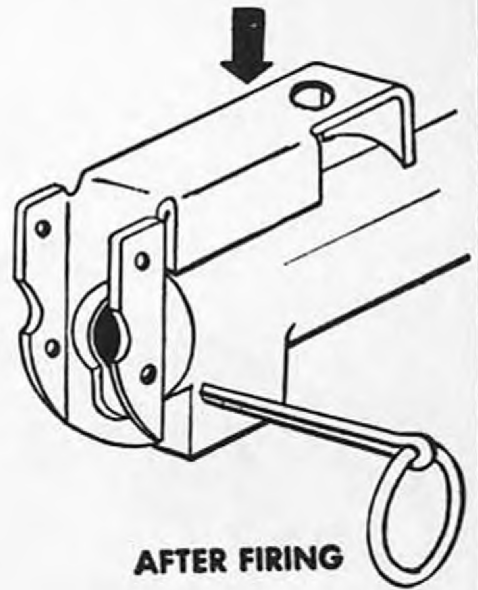

AFTER FIRING

PRESSURE OPERATION

SWITCH COMBINATION (AUST) MK.I

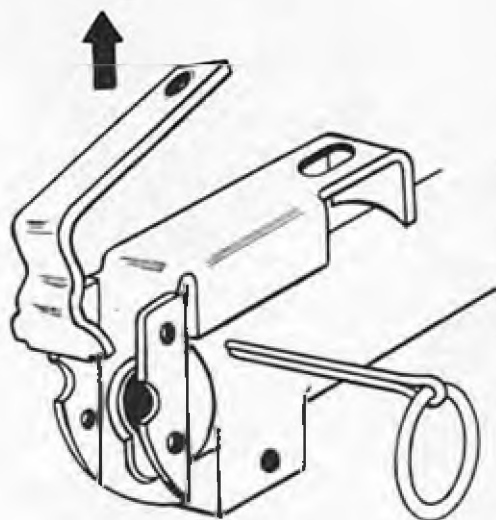
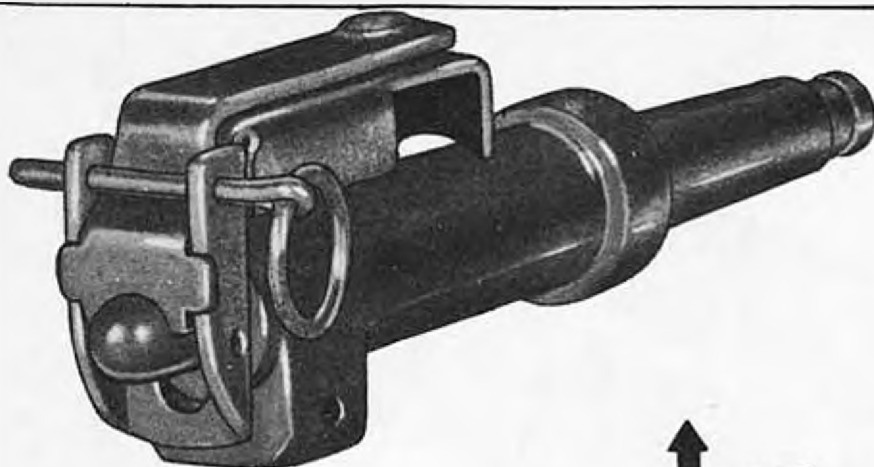

RELEASE OPERATION

AFTER FIRING

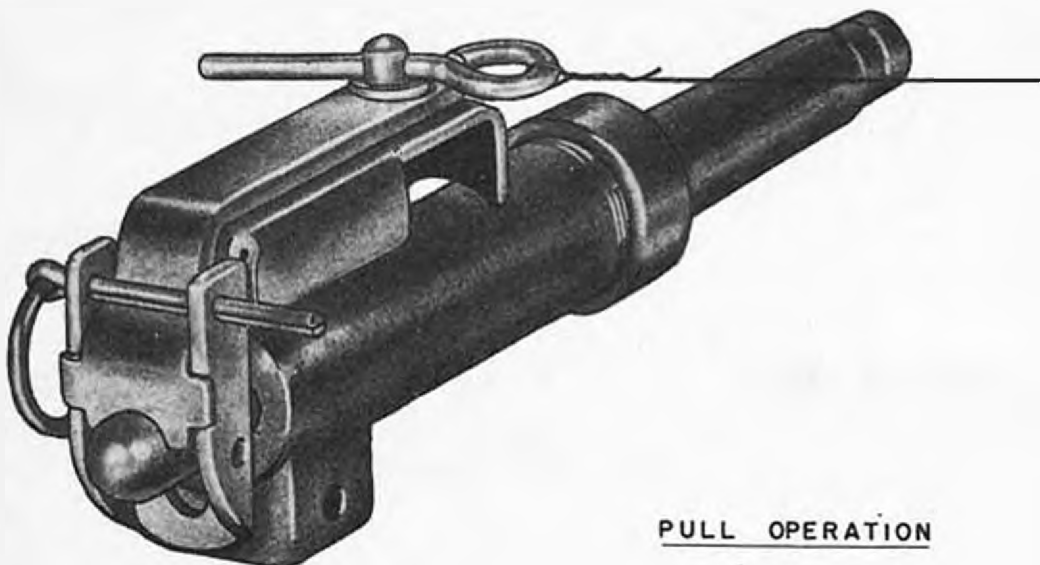

PULL OPERATION

WIDTH 5/8 in.
 HEIGHT 1-1/2 in.
 LENGTH 3-1/2 in.
 WEIGHT 3-3/4 oz. (w/o cartridge)
 MATERIAL Die cast brass and sheet metal
 OPERATING LOAD Pull: 10 lbs.
 Pressure: 11 lbs. 2 oz.
 Release: 1 lb. 4 oz.
 COLOR Unpainted metal

BRITISH SWITCH

COMBINATION (AUST) MK. I

(MURRAY SWITCH)

(SERVICE)

USE: This device is designed for use in anti-personnel mines and booby traps. It may be used as a pressure, pull, or release of pressure switch.

INSTALLING, ARMING, & FUNCTIONING:

1. Pressure Operation: To install this switch for pressure operation, remove the release pin, trigger pin, and release lever. Unscrew the collar, and remove the cartridge. With the blunt end of a pencil push back the striker until the narrow part of the keyhole slot in the release plate can engage in the groove in the striker. Insert the safety pin in the lower safety pin hole. Replace the collar and the cartridge case, and fit a detonator or fuse into the end of the cartridge case. Attach the switch to the charge or mine, and withdraw the safety pin.

Pressure on the release plate forces the plate toward the switch body, moving the keyhole slot downward, releasing the striker, and firing the percussion cap.

2. Pressure-release Operation: To install this switch for release operation, first set up the device as for pressure operation (above). Place the release lever in position over the release plate, and transfer the safety pin from the lower to the upper safety pin hole. Push the release lever and plate together toward the switch body until the tongue on the release lever engages in the slot in the end of the striker. Install the device, with weight restraining the lever, connect the charge, and remove the safety pin.

When the restraining load is removed from the switch, the release lever is disengaged from the slot in the striker. The freed striker, driven by its spring, then fires the percussion cap.

3. Pull Operation: To install this switch for pull operation, first set up the device as for release operation (above). Insert release pin through holes in the release lever and plate and insert trigger pin. Attach a trip wire to a stake, tree, etc., and then to the trigger pin. Connect the switch to the charge or mine, and withdraw the safety pin.

DISARMING: Insert the safety pin in the lower safety pin hole when the device is set for pressure operation; in the upper safety pin hole, when set for release or pull operation. Disconnect the switch and the detonator from the charge or the mine, then detach the detonator from the switch.

REMARKS: 1. Prior to re-use of this switch, examine the cartridge case to see whether an unfired cap is in place.

PERCUSSION IGNITER MK.III

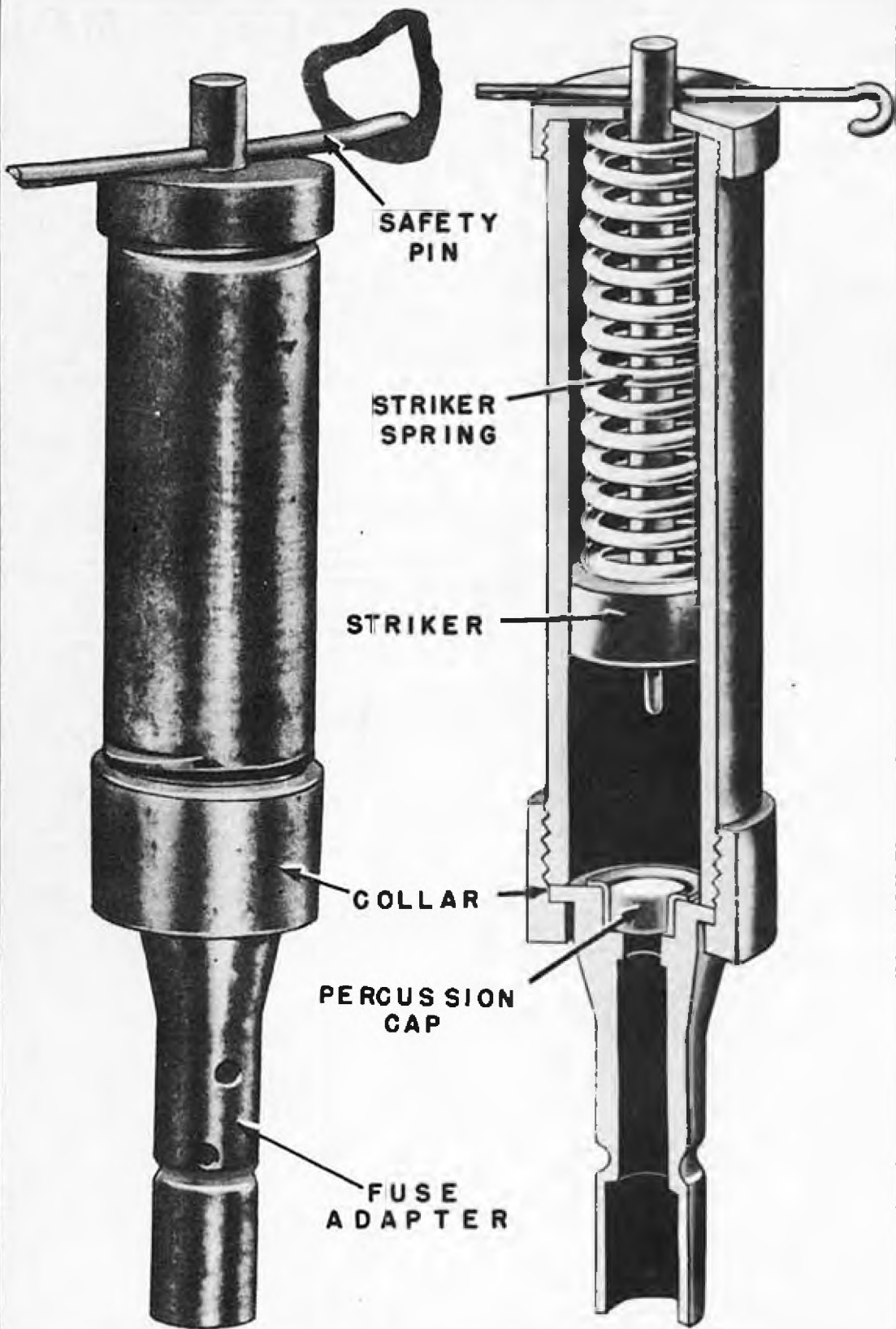

DIAMETER 3/4 in.
 LENGTH 3 in. (with adapter)
 WEIGHT
 MATERIAL Brass
 PULL REQUIRED 2-1/4 lbs.
 COLOR Unpainted brass.

BRITISH SWITCH
**PERCUSSION
 IGNITER**

Mk III

(OBSOLETE)

USE: This device may be used as a fuse lighter, manually operated, in firing demolition charges non-electrically. Operated by a trip wire, it may also be used to initiate improvised booby traps and mines. The device will ignite safety fuse directly, or fire detonators.

DESCRIPTION: The igniter consists of a cylindrical housing tube containing a spring-loaded striker. One end of the striker protrudes through a hole in the cap on the top of the housing tube and is held cocked by a safety pin. The lower end of the housing tube is externally threaded to receive a collar which holds the fuse adapter in place.

FUNCTIONING: A pull on the trip wire will remove the safety pin from the striker. The released striker will then be forced by its spring against the percussion cap in the fuse adapter, firing the fuse or detonator inserted in the adapter.

INSTALLING & ARMING: Fix the device in position, then connect the device to the explosive charge. Lead a trip wire from its anchor and attach it to the safety pin.

DISARMING: Examine each end of the trip wire, then cut the trip wire. Make certain that the safety pin is securely in place, then cut or detach the length of fuse or detonating cord leading to the charge or mine.

REMARKS: 1. This device may be re-used by recocking and replacing the percussion cap.

TRIP MECHANISMS NO. 4, 5, 6.

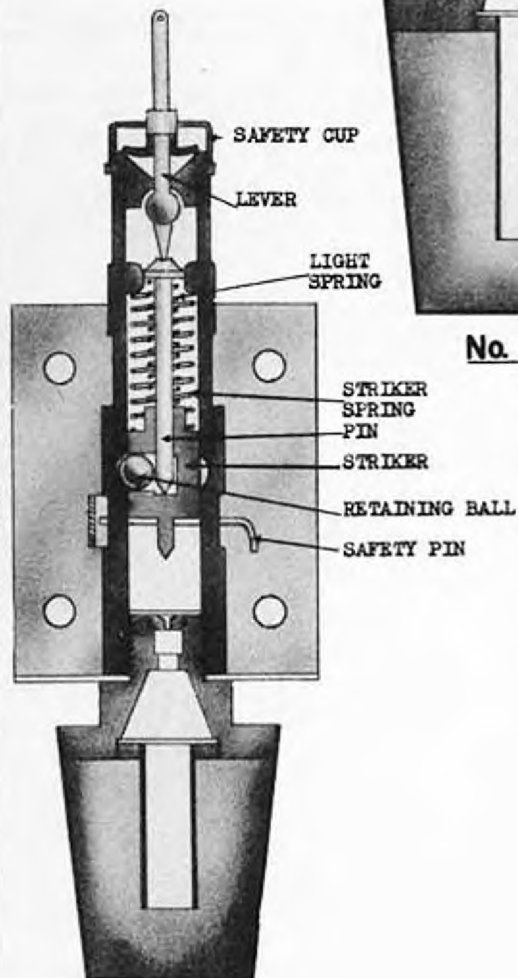
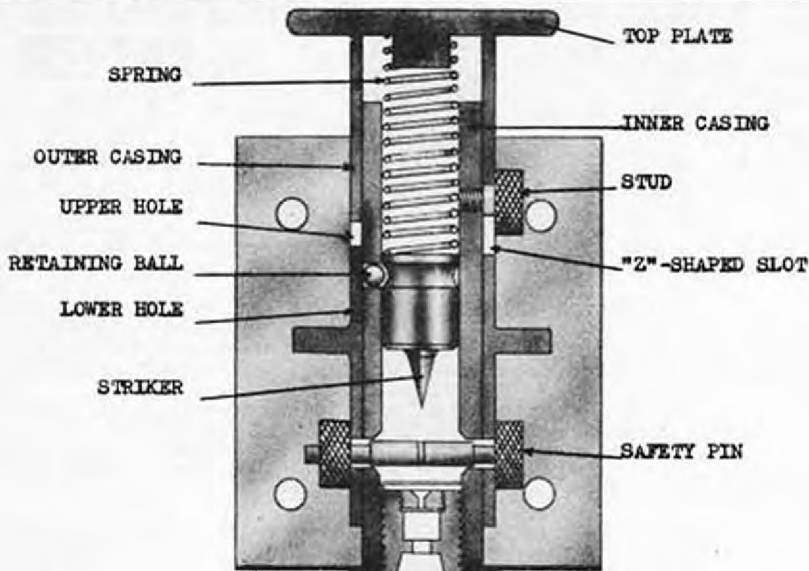

No. 4

No. 5

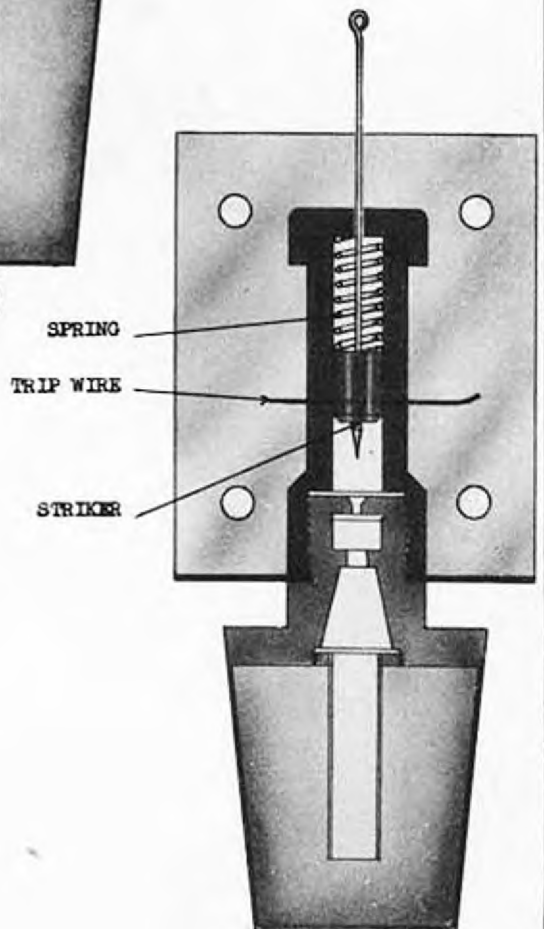

No. 6

DIAMETER (a) 0.65"
 (b) 1.5"
 (c) 0.75"
 LENGTH (a) 6.2" (with primer)
 (b) 5" (with primer)
 (c) About 4" (with primer)
 FULL OR PRESSURE
 REQUIRED (a)
 (b) 4 or 12 lbs.
 (c)
 COLOR Unpainted steel.

BRITISH TRIP MECHANISMS

A. NO. 4
B. NO. 5
C. NO. 6
 (OBSOLETE)

GENERAL:

These devices, Trip Mechanisms No. 4, 5, and 6, are all obsolete and are included in this publication for interest and information only. It is not expected that they will be encountered in operational use. Special note should be taken not to confuse these Trip Mechanisms with the British Switches No. 4, 5, and 6, which are in service use. Brief descriptions of the devices follow.

DESCRIPTION:

Trip Mechanism No. 4: This device is designed on the hair trigger principle and is intended to be actuated by very light pulls. It is so arranged that the pull can be taken in any direction, or a number of different trip wires can be attached to the actuating lever. With the safety clip removed, a pull on any trip wire attached to the trip lever will pivot the lever from the top of the retaining pin, which is then forced by its spring out of the striker block. The retaining balls are allowed to move inwards, releasing the striker and firing the percussion cap, which in turn sets off the detonator and attached primer.

Trip Mechanism No. 5: This mechanism can be used in any of three different ways, and is provided with a light and a heavy spring which can be used alternatively to create operating conditions of greater or less force. A setting stud is provided in "Z"-shaped groove. To obtain pressure operation, place the stud in the "Press" position of the groove. Depending on the spring used, a pressure of 4 or 12 lbs. will then cause the upper of the two holes in the outer case to come opposite the retaining ball, allowing the retaining ball to move outward and release the striker, firing the percussion cap, detonator and primer. Release operation is accomplished by placing the setting stud in the "Lift" position with a weight of more than 4 or 12 lbs., depending on the spring, placed on the top plate. Removal of the weight will allow the spring to force the inner casing upwards until the retaining ball comes opposite the lower of the two holes in the outer case. The ball then moves into this hole and releases the striker. The stud is placed in the "Press" position for pull functioning, and a trip wire is attached to the central plate in such a manner that a light pull on the wire will rotate the outer case until the stud is in the "Lift" position. Since there is no weight to restrain the mechanism, the device will function immediately as for release operation, described above. A safety pin, intervening between the striker and the percussion cap, pierces the inner and outer casings.

Trip Mechanism No. 6: This is a very simple device designed to be operated by direct pull only. It consists of a spring loaded striker retained by the end of a special composition wire. A pull on the wire will release the striker and fire the device. Each mechanism is provided with two feet of this wire, wrapped around the body of the device when issued. If a longer trip wire is desired, a length of standard trip wire is spliced to the free end of the special wire.

This Page is Blank

SECTION IV

BRITISH DEMOLITION CHARGES & EXPLOSIVES

ARMY EXPLOSIVES

<u>EXPLOSIVE</u>	<u>TYPE</u>	<u>WEIGHT</u>	<u>LENGTH</u>	<u>OVERALL DIAMETER</u>	<u>WIDTH</u>	<u>HEIGHT</u>	<u>EXPLOSIVE</u>	<u>EXPLOSIVE WEIGHT</u>	<u>WRAPPER</u>
Gelignite	Cartridge	1.6 oz.	3-3/8"	7/8"	--	--	60% Gelatine	1.6 oz.	Waxed paper
Gelignite	Cartridge	1/4 lb.	4"	1-1/4"	--	--	60% Gelatine	4 oz.	Waxed paper
"808"	Cartridge	1/4 lb.	3-1/2"	1-3/8"	--	--	Desensitized Polar Blasting Gelatine	4 oz.	Thin paper (Blue marking)
"808" Plastic	Cartridge	1/4 lb.	3-1/2"	1-3/8"	--	--	Desensitized Polar Blasting Gelatine (Plasticized)	4 oz.	Thin paper (Red marking)
Plastic H.E.	Cartridge	1/4 lb.	4"	1-1/4"	--	--	Plastic Explosive	4 oz.	Cellophane
Ammonal	Cartridge	1/4 lb.	5"	1-3/8"	--	--	Amatol/T.M.T. 80/20 with powdered aluminum	4 oz.	Rubberized fabric
Plastic H.E.	Cartridge	1/2 lb.	8"	1-1/4"	--	--	Plastic Explosive	8 oz.	Waxed paper
Guncotton Wet	Slab	1 lb.	6"	--	2-1/4"	1-3/4"	Guncotton, wet	1 lb.	--
C.E./T.N.T. Mixture II	Slab	1 lb.	4-1/2"	--	2-1/4"	1-3/4"	T.N.T./C.E., 75/25	1 lb.	Cardboard
T.N.T. Mx I	Slab	1-1/3 lb.	6"	--	3"	1-1/2"	T.N.T.	1-1/3 lb.	--
Ammonal	Block	25 lb.	9-1/4"	--	9"	9"	Amatol/T.N.T. 80/20, with powdered aluminum	25 lb.	Metal can
Ammonal	Block	50 lb.	12-1/4"	--	11-7/8"	10-1/4"	Amatol/T.N.T. 80/20, with powdered aluminum	50 lb.	Metal can

MILITARY (ARMY) EXPLOSIVES

I. DETONATORS (BLASTING CAPS)

The standard British military detonators are the following:

<u>Detonator</u>	<u>Type</u>	<u>Dimensions</u>	<u>Container</u>	<u>Explosive</u>	<u>Exp.Wt.</u>	<u>Remarks</u>
No.8 Mk VII	Non-electric	1 $\frac{1}{2}$ " x $\frac{1}{2}$ "	Copper tube	Mercury Fulminate	2 grams .057 oz.	Red
No.27 Mk I	Non-electric	1-3/4"x $\frac{1}{2}$ "	Aluminum tube	A.S.A. & Tetryl	9 grams .031 oz.	Replac- ing No. 8.
No. 33 Mk I	Electric	1-3/4" x $\frac{1}{2}$ "	Aluminum tube	"	"	"

II. PRIMERS:

Most British explosives are not initiated by a blasting cap or detonator directly, but rather by a special "Primer", or booster charge, placed between the detonator and the main charge. The following military primers are in use:

<u>Primer</u>	<u>Weight</u>	<u>Dimensions</u>	<u>Remarks</u>
Guncotton, dry Mks I & II	1 oz.	1 $\frac{1}{2}$ " x 1.35" to 1.15"	Surface gelatinized with acetone.
C.E. (Tetryl)	"	" " "	Wrapped in waxed paper
One centimeter		1 $\frac{1}{2}$ " x 1 cm.	Copper tube - mixture of TNT & Tetryl, and PETN

III. EXPLOSIVES:

British Military explosive charges are indicated in chart form on page 76.

IV. BANGALORE TORPEDOES:

1. Torpedo, Bangalore, 2", Mks. I & II:

This torpedo, 62.5" long and weighing about 25 lbs., consists of a steel body fitted with an ogival hardwood head and contains a charge of about 7 lbs. of Ammonal with a Mk II C.E. primer fitted at the front end. Two studs are provided near the rear end of the body for assembly of the sections in series. The body is painted Service Green or Brown, with a red band, below which are located identification stencillings. Two 1/4 inch buff bands enclose a 1 inch green band on which the letter 'A' is stencilled to denote the Ammonal filling.

2. Torpedo, Bangalore, E.P., Lightweight, 20 ft:

This torpedo is issued empty in sections 3 ft. long and 3 in. in diameter, and is made of light sheet steel. Each section is split longitudinally down the center to form a top and bottom half section. A wooden nose plug, a wooden tail plug, six junction bands, and nine junction rings are issued with each outfit of seven complete sections of the torpedo. The torpedo was originally designed to be used in conjunction with 20 ft. Flexible Torpedo, described below, as its filler. But it may be filled with cartridge type explosive without any canvas lining.

3. Torpedo, Bangalore, E.P., Flexible, 20 ft:

This torpedo consists of a 20 ft. length of 2" diameter canvas hose, filled with "808", Gelignite, or Ammonal. A double length of Cordtex, passing through regularly spaced primers, runs through the explosive filled hose. The torpedo was designed as an assault demolition weapon to be used in single lengths coiled or bundled, or stretched out and tied to other lengths. When rigidity is desired, this torpedo may be placed inside of the 20 ft. Lightweight Torpedo, described above.

4. Torpedo, Bangalore, Lightweight, 1-1/2", Mk. I:

This torpedo consists of a thin steel tube, 1-5/8" diameter and issued in two lengths, 6 ft. and 10 ft. The torpedo is painted brown, with a red band, below which are painted identification stencillings. Two 1/4" buff bands enclose a 1" green band on which the letter 'A' is stencilled to indicate the Ammonal filler. An ogival wooden head fastened to a short metal sleeve with screws is provided with each set of four sections. A studded metal band is provided with each section by means of which sections may be joined together.

ARMY SHAPED CHARGES



STOCK CHARGE



ARCHED CHARGE
(GENERAL WADE)

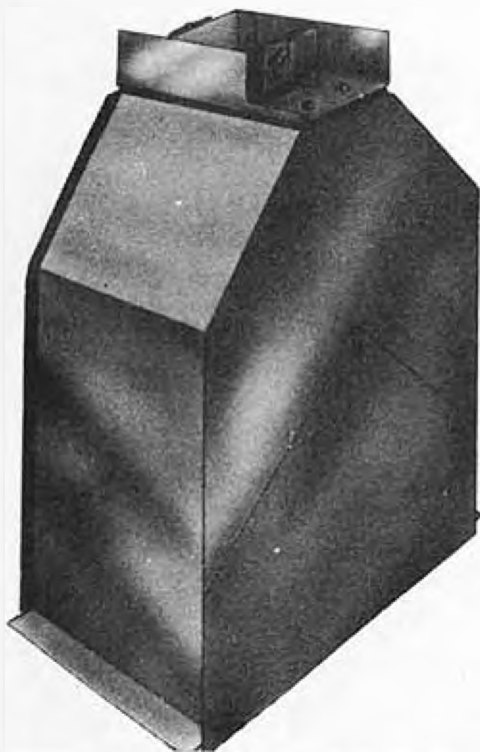

HAYRICK CHARGE

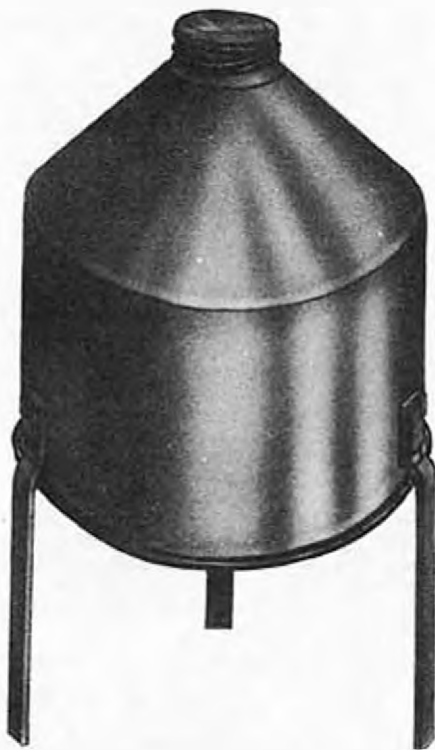

BEEHIVE CHARGE

MILITARY (ARMY) EXPLOSIVES - continuedV. SHAPED CHARGES:A. "STOCK" Charges:

1. Charge, Demolition, 5 oz., Mk I, Stock and Charge, Demolition, 7 oz., Mk II, Stock

This is a small linear shaped charge, consisting of a tin outer casing, 6" x 1-5/16" x 2", with an 80 degree angle copper arch fitted so that the apex is 1-3/8" above the base. The charge is designed to cut 1" of steel. Two Cordtex leads are led through a groove in the top of the charge, above a series of primer pellets, and are held in place by four straps soldered to the outer casing. About 4 1/2 inches of the Cordtex project from either end of the charge as leads. A 10" tinned copper wire is soldered to each corner of the charge to provide a method of fixing the charge or of connecting two or more charges together.

The 5 oz. Mk I and the 7 oz. Mk II charges are exactly similar, except that the latter is two inches longer than the former.

B. "BEEHIVE" Charges:

1. Charge, Demolition, No. 1, 6" Mk III/Beehive.

The Mk III Beehive is a ten pound shaped charge containing 6-3/4 lbs. of Pentolite. The charge measures 6" in diameter and 7" in length, with three 4 1/2" legs attached to the base to give the proper stand-off distance. An 80 degree sheet steel cone is fitted to give the Munroe effect. A removable cap on top of the container covers a primer tube containing the primers into which the detonator is inserted.

2. Other Beehive Charges:

From time to time, other sizes of Beehives have been used by the British Army, as follows:

- a) Charge, Demolition, No. 6, Mk I (16/25 lb.)
- b) Charge, Demolition, H/C, 30 lb. Mk I (Nesting)
- c) Charge, Demolition, No. 7, Mk I (35/50 lb.)
- d) Charge, Demolition, No. 8, 80 lb. Mk I
- e) Charge, Demolition, No. 4, 75 lb. Mk I (H/C)

C. "ARCHED" Charges:

1. Charge, Demolition, No. 2, 25 lb. Mk I/Arched, ("General Wade"):

This charge is an arched linear charge, containing 26 lbs. of Pentolite. The container is made of tinplate and measures 9" x 12-3/4" x 6-3/8". The container is semi-cylindrical, with a 2-1/4" radius arch fitted into the bottom to give the focal charge effect. The charge is designed to be a general purpose charge, combining some of the advantages of the coned type of charge with those of the ordinary contact type. It is thus adequate to effect serious damage against the majority of targets likely to be encountered by assault troops, i.e., against reinforced concrete and armor plate up to 2" thickness.

2. Charge, Demolition, 26 lb., Arched ("M.S. Shape"):

This charge is a slight adaptation of the "General Wade", described above. The thickness of the explosive at the top has been reduced to 2 1/2", and the base pressure charge has been increased by about 50%, giving the following dimensions, 9" x 17" x 5".

D. "HAYRICK" Charges:

1. Charge, Demolition, No. 3, 15 lb. Mk I/Hayrick:

The Hayrick charge is a linear shaped charge designed to cut the tension reinforcing bars of reinforced concrete structures. It consists of a mild steel body containing the H.E. filling, with a blast plate fitted internally to provide the hollow charge effect. The body is rectangular in shape, measuring 11 1/2" x 6" x 17 1/2". One end is open and formed with flanged end plates, while the opposite end is shaped to an apex and carries two detonator sleeves, a sealing plate, and the fuze support. About 15 lbs. of Pentolite make up the H.E. filler, bring the total weight to about 27 1/2 lbs.

MAGNETIZED CHARGES

CLAM MK. III

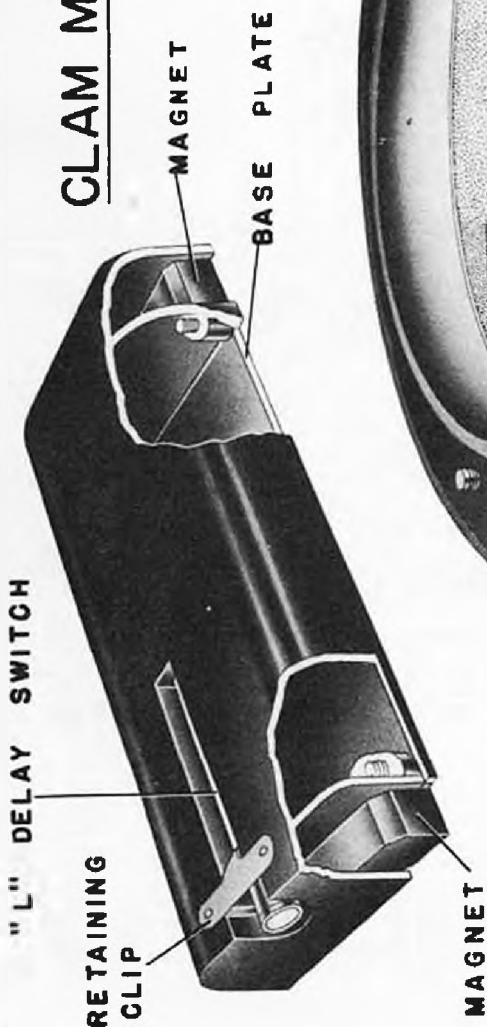

LIMPET MK III

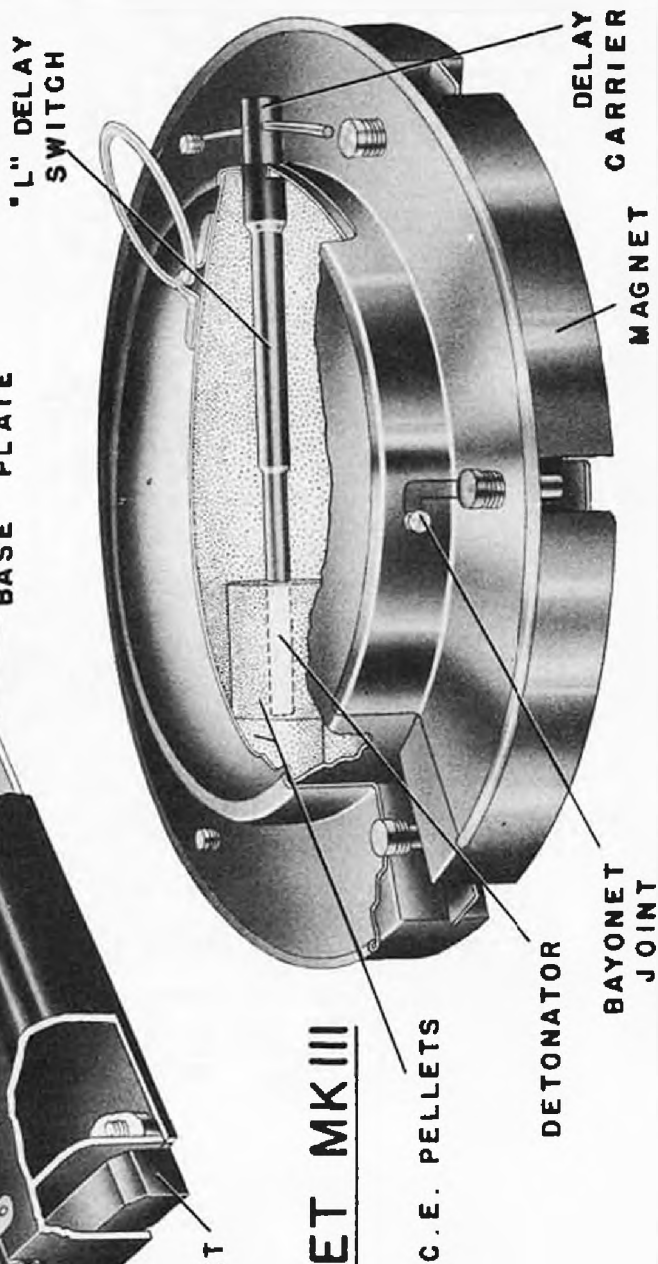

MILITARY (ARMY) EXPLOSIVES - continuedVI. MAGNETIZED CHARGES:A. The "CLAM" Mk III:

The Clam is a small time bomb with a magnetic base which enables it to be attached instantly to any flat iron or steel surface, such as engine blocks, railroad tracks, steel plate, etc.

The body is a black plastic box with rounded corners, measuring 5-3/4" x 2-3/4" x 1-1/2". At each end of the box is a magnet compartment, the two magnets being loosely mounted so that they can grip an uneven surface. The center compartment of the box contains about 8 oz. of the H.K. filler (usually TNT/Tetryl, 55/45) and is closed by a flat lid held in place with four screws.

A standard Switch No. 9 "L" Delay Mk I (Lead-break), with a No. 27 detonator attached, serves as the initiator. It slips into a groove in the top part of the body and is held in place by a small clip.

B. The "LIMPET" Mk III:

The Limpet is a small self-contained delay-action mine with a magnetic base which allows it to be fitted instantly to any iron or steel target, such as a tank or the hull of a ship.

Designed to function either on land or under water, the Limpet carries a charge of 3 1/2 lbs. of H.K. filler (usually TNT/Tetryl 55/45) - sufficient to pierce 60 mm. plate. Exceptionally powerful segmental magnets, flexibly mounted, allow it a firm grip even on uneven surfaces. It will remain in place on the average vessel at speeds up to 16 knots.

The explosive container of the Mk III Limpet is a separate unit which can be detached from the magnet ring so that the device can be used without magnets if desired. This container filled weighs about 4 1/2 lbs. The magnet ring weighs 5 1/2 lbs., bringing the total weight of the device to 9 1/2 lbs.

A standard Switch No. 9 "L" Delay Mk I (Lead-break), with a No. 8 detonator attached, serves as the initiator. It is inserted in a special holder, which gives a watertight joint when inserted in the magazine.

A carrying ring is fitted to the top of the Limpet body.

The earlier Mk II Limpet was fitted with two magazines for a duplicate igniter system to provide against possible failure.

VII. FUSE - SAFETY, INSTANTANEOUS, & DETONATING:A. Safety Fuse:

1. Fuse, Safety, No. 11, Mks I & II:

This fuse consists of a column of fine gunpowder enclosed in a Jute yarn covered with a bitumen coating protected by a varnished black tape, the whole having a diameter of about .21 inches. It burns at about 2 ft. per second and will function under water.

B. Instantaneous Fuse:

1. Fuse, Instantaneous, Mk III:

This is not a detonating fuse, but it can be ignited by safety fuse or flame, and burns at not less than 90 ft./sec. It is enclosed in an orange colored tape binding.

2. Fuse, Instantaneous, Mk IV:

This fuse is similar to the Mk III fuse, except that it is enclosed in red-colored water-proof tape.

C. Detonating Fuse:

1. Fuse, Instantaneous, Detonating, TNT, Mk III (P.I.D.):

This fuse consists of a lead and tin alloy tube about .23 inches in diameter filled with specially prepared TNT. It detonates at a rate of 5,000 meters/sec.

NAVY EXPLOSIVES

EXPLOSIVE	TYPE	EXPLOSIVE WEIGHT	CENTRAL DIAMETER	WIDTH	HEIGHT	TOTAL WEIGHT	CONTAINER	REMARKS
C.E./T.H.T.	Block, Mk I	14 oz.	--	2-1/4"	1-7/8"	14 oz.	Metal	May be made up into a 25 ft. "chain" demolition charge.
T.H.T.	Block, Mk I	1-1/4 lb.	2.4"	--	--	1-1/4 lb.	Paper	Usually inserted in a Mk I TNT Container, made of sheet steel
Amatol	Charge, Mk I	10 lb.	6.5"	--	--	18-1/2 lb.	Mild Steel	Receives one 4 oz. primer and No. 6 detonator.
Amatol	Charge, Mk I	25 lb.	6.6"	--	--	39-1/2 lb.	Mild Steel	Receives two 4 oz. primers and No. 6 detonators.
Amatol	Charge, Mk II	25 lb.	6.6"	--	--	41 lb.	Mild Steel	Receives one TNT 1-1/4 lb. fitted demolition charge.
Amatol	Charge, Mk I	50 lb.	8"	--	--	70-1/2 lb.	Mild Steel	Receives two 4 oz. primers and No. 6 detonators.

MILITARY (ARMY) EXPLOSIVES - continuedDetonating Fuse (cont'd):2. Cordeau-Bickford:

Consists of a lead tube completely and uniformly filled with TNT. Detonates at about 4,500 meters/sec.

3. Fuse, Instantaneous, Detonating, Cordtex, Mk IV:

Consists of a core of PETN surrounded by a cellophane tape and enclosed in layers of jute and cotton yarn contained in a tubular covering of waterproof composition resembling aluminum in color. The external diameter is .19 inches. Detonation rate is approximately 20,000 ft/sec.

Some issues of Cordtex will be covered with rubberized tape instead of cellophane tape. Packages containing these issues will be marked "R". Packages containing Cordtex covered by plastic instead of bitumen will be marked "P".

NAVAL EXPLOSIVES

I. DETONATORS:

Six standard service detonators are presently in use by the British Navy. Five are authorized for shipboard use, but the No. 21 and No. 25 are classed as obsolescent and are being replaced by the No. 6 Briska detonators.

<u>DETONATOR</u>	<u>TYPE</u>	<u>MATERIAL</u>	<u>EXPLOSIVE</u>	<u>EXP. WT.</u>	<u>REMARKS</u>
No. 21 Mk VII	Electric	Copper tube	ASA/CE	33 grains	Obsolescent
No. 25 Mk II	Non-Elect.	Copper tube	ASA/CE	33 grains	" Painted red
No. 6 Briska Mk II	Electric		ASA/RDX	15 grains	
" No. 6 Briska Mk III	Electric		ASA/RDX	15 grains	36" leads
No. 6 Briska Mk II	Non-Elect.		ASA/RDX	15 grains	
ICI Gasless Delay, No. 1	Electric		ASA/CE		1 sec delay

* The No. 6 Briska, Mk III is identical to the Mk II, except that it has 36" wire leads. It is issued for limited use in salvage work and is not supplied for general Naval service.

II. PRIMERS:A. C.E. Primers for Shipboard Use:

1. Mks I & II: The Mk I primer consists of a watertight cylindrical brass case, 2.25" x 1.18", containing 1-1/7 oz. of C.E. The Mk II is identical to the Mk I, except that as a wartime measure a paper wrapper has been substituted for the brass case. The Mk II is not waterproof, but may be used under water provided immersion does not exceed one hour.

2. Mk III: This primer is identical in dimensions and weight to the Mk II (above) but the detonator recess is of smaller diameter to fit the Briska No. 6 detonators and the ICI Gasless No. 1 detonator.

B. Polar Blasting Gelatine Primers for Shore Demolitions:

1. These two primers are plastic, and thus have no recess provided for the detonators. The primers are paper wrapped in cartridges, dimensions and weights as follows:

<u>Primer</u>	<u>Dimensions</u>
2 oz. Primer	2-1/4" x 1-1/8"
4 oz. primer	4" x 1-1/4"

These primers are for shore demolitions only and are not for shipboard issue.

NAVAL 5 LB. CAVITY CHARGE

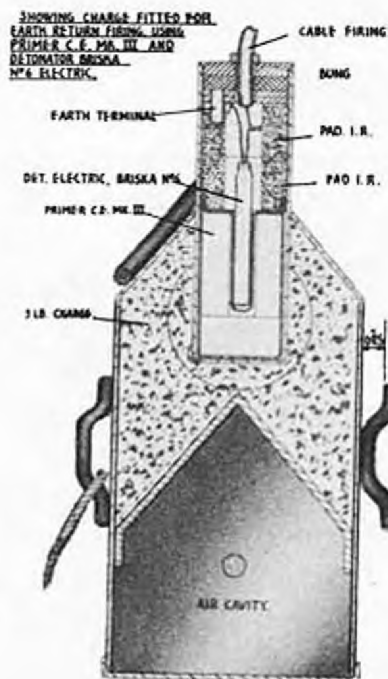
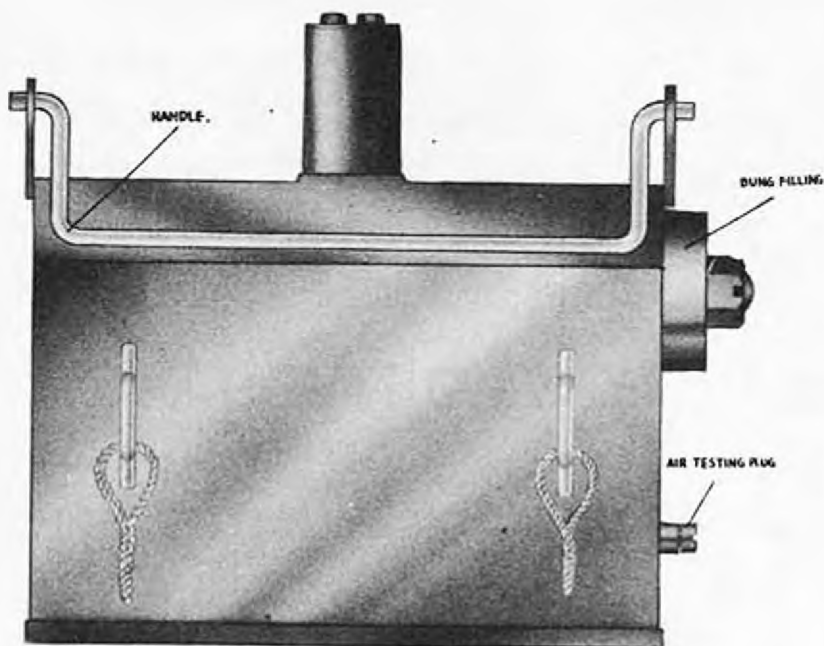

NAVAL EXPLOSIVES - continued

III. EXPLOSIVES:

British Naval explosive charges are indicated in chart form on page 82.

In addition to these, heavy demolitions are sometimes accomplished by adapting Depth Charges Mk VII, Mk VIII, Mk XI, and "D" Mks I & II, and Mine Charge Case Mk V for demolition firing.

IV. SHAPED CHARGES:1. Charge, Cavity, 5 lb. RDX/TNT, Demolition, Mk I:

This charge is a linear shaped charge designed for cutting chain, steel wire rope, steel plate, etc. The charge consists of approximately five lbs. of 60/40 RDX/TNT. The primer pocket will accept either a primer C.E. Mk I, II, or III, or a 2 oz. Polar Blasting Gelatine primer. The charge has been designed for use with detonators Briska No. 6, and is not suitable for use with No. 21 or No. 25 detonators. An ICI No. 1 Gasless Delay detonator may be used when the charge is fitted with a Mk III C.E. primer.

The thin sheet steel case encloses the water-tight cavity, and the case and primer tube bung are watertight, allowing the charge to be used in depths up to 3 fathoms.

Two cleats and 6 ft. lanyards attached to the charge enable it to be quickly secured to its target.

V. FUSE - SAFETY, AND DETONATING:A. Safety Fuse:

1. Fuse, Safety No. 9 Mk IV:

This is a standard service fuse, frequently known as "Bickford's", used for detonators No. 25. The rate of burning is approximately 2 ft/min. This fuse is of larger diameter than No. 11, or No. 100, and when used with Briska No. 6 detonators, the outer layer must be peeled back before the fuse can be inserted in the detonator.

2. Fuse, Safety, No. 11 Mk II:

See page 81.

3. Fuse, Safety, No. 100:

This fuse is smaller in diameter than Service safety fuse and can be used only with Briska No. 6 detonators. Burning rate is approximately 2 ft/min. The fuse is weather-proofed, not water-proofed, but will burn under water not exceeding 10 fathoms, provided it has not been immersed for more than 15 minutes.

B. Detonating Fuse:

1. Cordtex:

See page 83.

2. P.I.D.:

See page 81.

ADDITIONS & CORRECTIONS TO BRITISH LAND MINES & FIRING DEVICES

For record purposes, these sheets are to be considered a part of "Additions & Corrections to British Bombs & Fuzes, No. 1". No separate entry should be made in the record sheet.

It is suggested that the corrections be cut out and pasted in the proper page of the book where possible.

Page i (Index) - In Section III, below "Trip Mechanism No. 6", add:

A.C. Delay Igniter, Mk. I (for Rigid Limpet) 81a

Page ii (Index) - Under "Army Magnetized Charges", add:

Rigid Limpet 81

A.C. Delay Igniter, Mk. I (for Rigid Limpet) 81a

Opposite "Army Fuse (Safety, etc.)", delete "81" and add "81b".

Insert attached pages in their proper position.

====

Shrapnel Mk. I & II 25

Military Explosives 81-82

RESTRICTED

DIAMETER 3-1/2 in.
HEIGHT 5-1/2 in.
TOTAL WEIGHT 10 lbs.
EXPLOSIVE WEIGHT 1 lb.
EXPLOSIVE Amatol
MATERIAL Cast Steel
COLOR Yellow
FUZE Special
PULL REQUIRED 4 lbs.

BRITISH WINE

SHRAPNEL MK. 1& II

(ANTI-PERSONNEL)

(SERVICE)

(For Shrapnel Mk I, see REMARKS
below)

USE: This mine is a bounding anti-personnel mine designed to cause casualties up to 30 yds.

COMPONENTS: The mine consists of the following component parts: the outer mine canister, the inner case, the detonator pistol mechanism, and the cartridge pistol mechanism.

(a) Outer Mine Canister: The canister is nothing more than a container for the inner case and acts as a small mortar to propel the inner case into the air. The inner case rests on a shoulder in the bottom of the outer canister, and below this shoulder in the canister is a small recess acting as an expansion chamber for the propellant gases. A long recess is located on the outside of the canister into which the lever of the detonator pistol slides.

(b) Inner case: The inner case is a cylindrical container for the explosive charge. Two holes are located in the top of the inner case, one passing completely through the case for the insertion of the cartridge pistol, the other leading into the explosive charge for the insertion of the detonator pistol mechanism. During normal shipment and storage the inner case is held in the outer canister by two screws passing through the bottom of the canister into the case. These screws must be removed from the mine before it is laid.

(c) Detonator Pistol Mechanism: The detonator pistol is the actuating mechanism for the explosive charge of the mine. It consists of a cylindrical body containing a spring-loaded striker retained by a small fork attached to the end of a long lever arm. The lever is held in the retaining position both by a safety pin and a long recess in the outer canister into which it fits. When the lever is released, the striker is forced by its spring into a detonator inserted in a well beneath the pistol.

(d) Cartridge Pistol Mechanism: The cartridge pistol is the activating mechanism for the mine. It consists of a cylindrical body housing a spring-loaded striker. This striker is retained by a fork-shaped trip plate which fits under a shoulder on the top of the striker and above the top of the fuze body. A slot for attaching a trip wire is provided in the trip plate. A safety pin passes through the top of the striker and also through a groove cut in the trip plate, preventing the trip plate from being withdrawn.

ASSEMBLY & ARMING: First make certain that the two transit screws holding the inner case in the outer canister are removed. Unscrew the cartridge pistol with the spanner provided. See that cartridge recess is clear and insert ballistite cartridge provided with each mine. Replace the cartridge pistol and screw tight, making certain that safety pin is secure. Remove the detonator pistol, making certain that the safety pin is in place. Inspect the socket to see that it is clear, and insert the detonator, small end first, so that the cap end rests on a shoulder in the socket. Replace the detonator pistol so that its firing lever engages in recess on outer canister. Make certain safety pin is secure. Place mine in ground and attach a loose trip wire to the cartridge pistol. Remove detonator pistol safety pin, then remove cartridge pistol safety pin. If safety pin cannot be withdrawn easily, release tension and reset the trip plate.

NEUTRALIZATION: Replace cartridge pistol safety pin, then replace detonator pistol safety pin. Cut the trip wire, then disarm the mine by reversing the procedure for arming, removing detonator and cartridge.

FUNCTIONING: A pull of four pounds or more on the trip wire will remove the trip plate from the cartridge pistol, allowing the striker spring to force the striker into the cartridge located beneath the pistol. The explosion of the ballistite cartridge provides the propellant force which throws the inner case into the air. When the inner case leaves the outer canister, the lever arm is released, freeing the striker in the detonator pistol, which then is forced into the detonator located below the pistol. The explosion of the detonator fires the main charge of the mine.

REMARKS: 1. Mine, Shrapnel, Mk I: The Mk I mine is the earlier issue of the Shrapnel mine and differs from the Mk II only slightly, as follows:

SHRAPNEL MINE MK. I

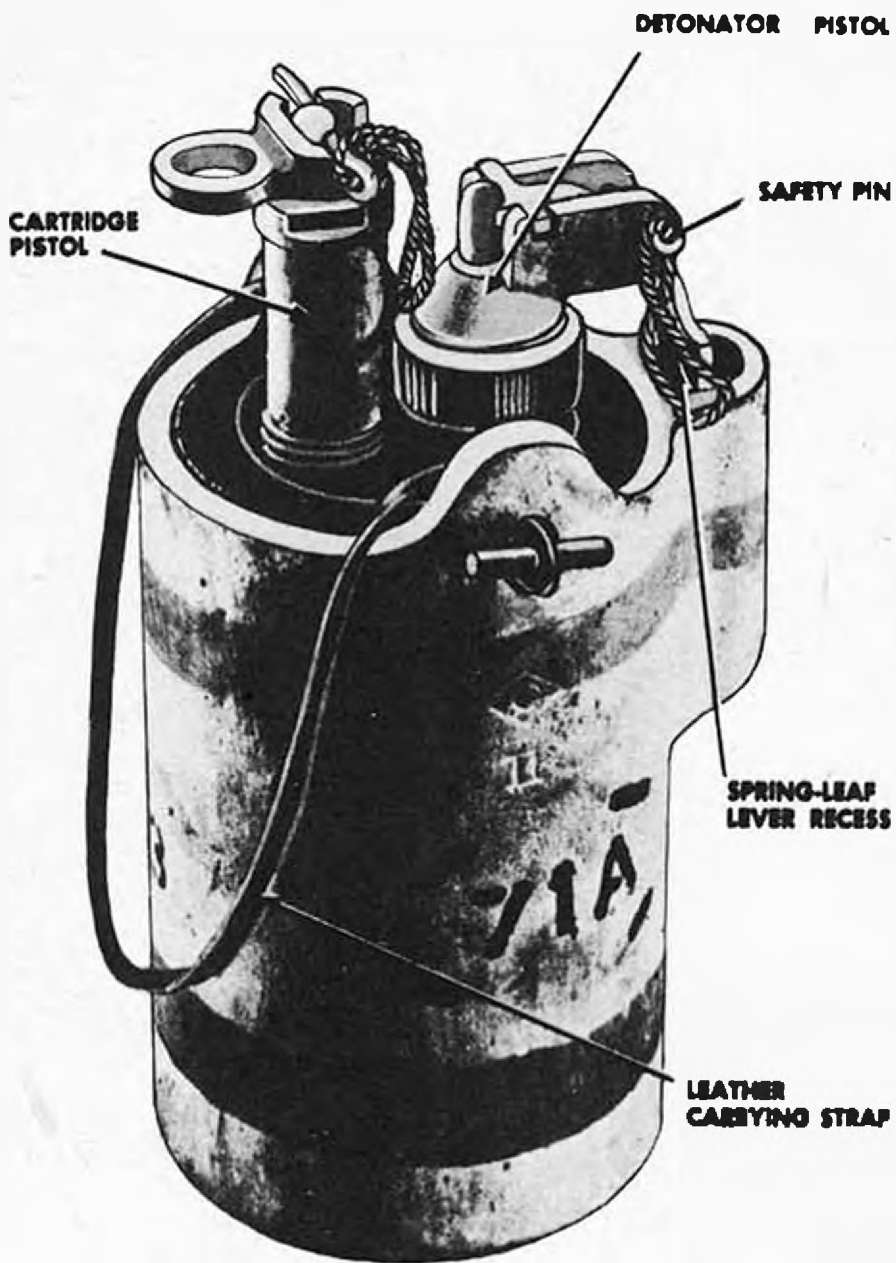

MILITARY (ARMY) EXPLOSIVES - continuedVI. MAGNETIZED CHARGES:A. The "CLAM" Mk III:

The Clam is a small time bomb with a magnetic base which enables it to be attached instantly to any flat iron or steel surface, such as engine blocks, railroad tracks, steel plate, etc.

The body is a black plastic box with rounded corners, measuring 6-3/4" x 2-5/4" x 1-1/2". At each end of the box is a magnet compartment, the two magnets being loosely mounted so that they can grip an uneven surface. The center compartment of the box contains about 8 oz. of the H.E. filler (usually TMT/Tetryl, 85/45) and is closed by a flat lid held in place with four screws.

A standard Switch No. 9 "L" Delay Mk I (Lead-break), with a No. 27 detonator attached, serves as the initiator. It slips into a groove in the top part of the body and is held in place by a small clip.

B. The "LIMPET" Mk III:

The Limpet is a small self-contained delay-action mine with a magnetic base which allows it to be fitted instantly to any iron or steel target, such as a tank or the hull of a ship.

Designed to function either on land or under water, the Limpet carries a charge of 3 1/2 lbs. of H.E. filler (usually TMT/Tetryl 85/45) - sufficient to pierce 60 mm. plate. Exceptionally powerful segmental magnets, flexibly mounted, allow it a firm grip even on uneven surfaces. It will remain in place on the average vessel at speeds up to 16 knots.

The explosive container of the Mk III Limpet is a separate unit which can be detached from the magnet ring so that the device can be used without magnets if desired. This container filled weighs about 4 1/2 lbs. The magnet ring weighs 5 1/2 lbs., bringing the total weight of the device to 9 1/2 lbs.

A standard Switch No. 9 "L" Delay Mk I (Lead-break), with a No. 8 detonator attached, serves as the initiator. It is inserted in a special holder, which gives a watertight joint when inserted in the magazine.

A carrying ring is fitted to the top of the Limpet body.

The earlier Mk II Limpet was fitted with two magazines for a duplicate igniter system to provide against possible failure.

C. The Rigid Limpet:

The British "Rigid" Limpet is designed for destruction of tanks or other steel structures. The device is painted field gray and consists of a rectangular box of sheet brass, 8-1/4" long, 2-7/12" wide, and 2-7/12" deep.

The box contains a charge of 2.5 lbs. of plastic H.E., moulded to accept a detonator at each end.

A pair of brass brackets are riveted to either side of the brass body, and a brass rod is secured between each pair of brackets. To each rod are fitted three permanent U-shaped magnets, each fastened by metal straps to a rubber mounting. These magnets are retained in position by flanges on the rod. The rubber mountings allow limited movement to the magnets so that the Limpet can be readily attached to uneven surfaces.

An internally threaded brass cap provides a filling hole. A threaded adapter fixed centrally to the brass filling cap and another threaded adapter fitted to the other end of the body provides means for inserting the A.C. Delay Igniter Mk. I, with which the Limpet is fused.

(See page 81 A for drawing of the Rigid Limpet.)

MAGNETIZED CHARGES

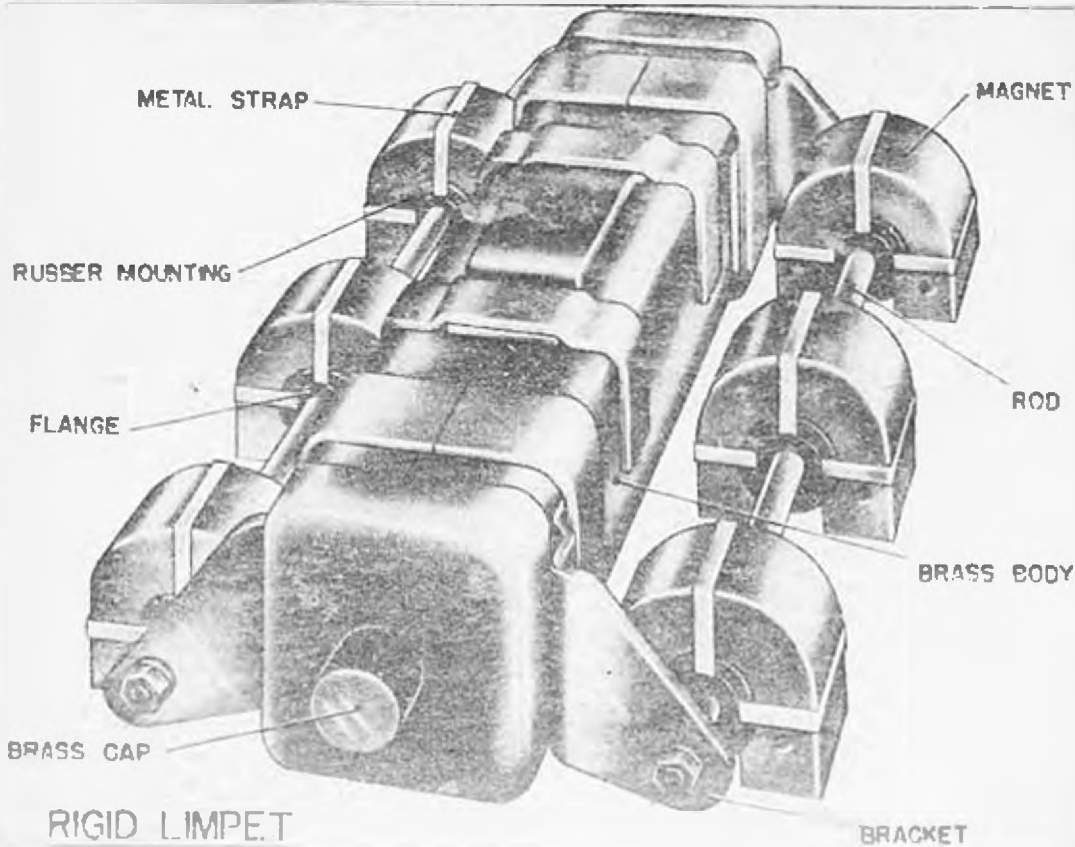

RIGID LIMPET

BRACKET

MILITARY (ARMY) EXPLOSIVES - continued

A. S. Delay Igniter, Mk. I:

The detonating mechanism used with the Rigid Limpet is a chemical type long delay device, consisting of a brass body containing a spring-loaded striker. The head of this striker is sunk in a celluloid disc, containing the striker under spring compression.

Immediately above the celluloid disc are located cotton wadding and a glass ampoule of solvent accommodated in an enlarged recess in the body. The top of the body is threaded externally to receive a threaded cap. Screwed into the center of the cap is a threaded spindle which bears on a rubber sealing disc. To the top of the spindle is attached a wing to permit manual operation. A safety pin pierces the threaded spindle and the cap, preventing the spindle from being screwed down as long as the pin is in place.

The device is put in operation by removing the safety pin and screwing down the threaded spindle, crushing the ampoule and allowing the solvent to saturate the cotton wadding and work on the celluloid disc. Eventually the celluloid is sufficiently softened to release the striker, which is then forced by its spring into the detonator threaded to the lower end of the body.

Dimensions and functioning details of the igniter follow:

Overall Length	8-1/2"
Detonator Length	4-1/2"
Max. Body Diameter	1"
Delay Times at 20° C.	Red ampoule . . . 4 hr.
(Delay times will increase	Orange ampoule . . 7 hr.
at temperatures above 20 ;	Yellow ampoule . . 14 hr.
decrease, below.)	Green ampoule . . 22 1/2 hr.
	Blue ampoule . . . 36 hr.
	Violet ampoule . . 4 1/2 days

MAGNETIZED CHARGES

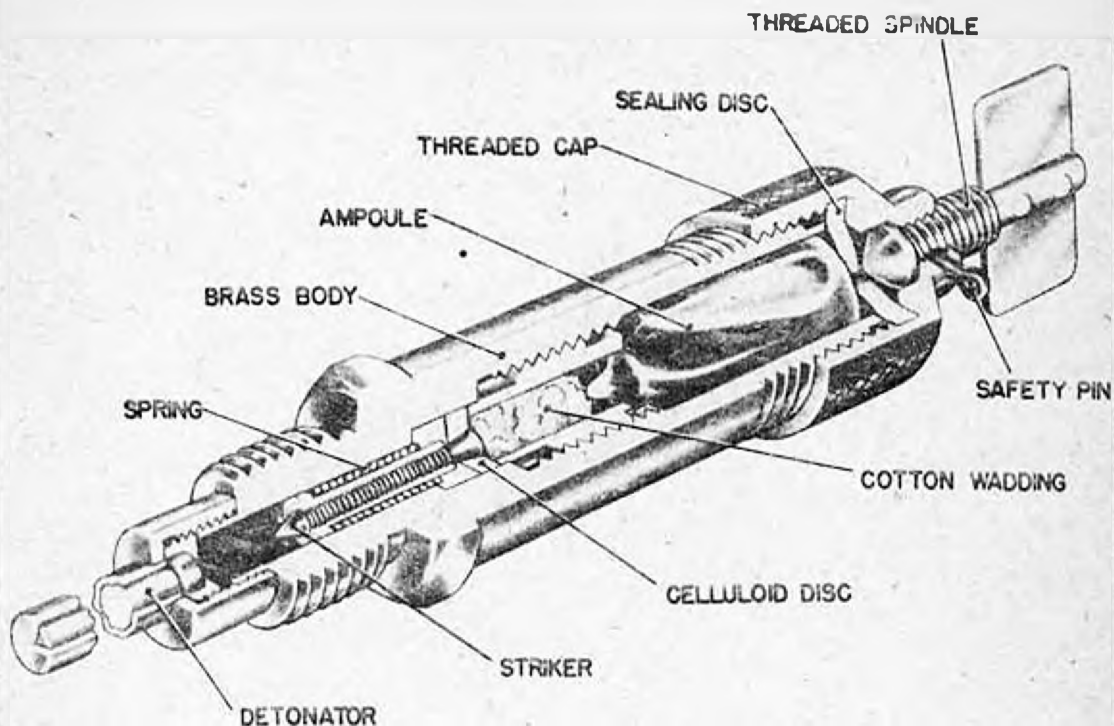

A.C. DELAY IGNITER MK. I

MILITARY (APR) EXPLOSIVES - continued

VII. FUSE - SAFETY, INSTANTANEOUS, & DETONATING:

A. Safety Fuse:

1. Fuse, Safety, No. 11, Mks I & II:

This fuse consists of a column of fine gunpowder enclosed in a jute yarn covered with a bitumen coating protected by a varnished black tape, the whole having a diameter of about .21 inches. It burns at about 2 ft. per second and will function under water.

B. Instantaneous Fuse:

1. Fuse, Instantaneous, Mk. III:

This is not a detonating fuse, but it can be ignited by safety fuse or flame, and burns at not less than 90 ft. per second. It is enclosed in an orange colored tape binding.

2. Fuse, Instantaneous, Mk. IV:

This fuse is similar to the Mk. III fuse, except that it is enclosed in a red-colored water-proof tape.

C. Detonating Fuse:

1. Fuse, Instantaneous, Detonating, TNT, Mk. III (F.I.D.):

This fuse consists of a lead and tin alloy tube about .23 inches in diameter filled with specially prepared TNT. It detonates at a rate of about 5000 meters per second.

NAVY EXPLOSIVES

<u>EXPLOSIVE</u>	<u>TYPE</u>	<u>EXPLOSIVE WEIGHT</u>	<u>LENGTH</u>	<u>OVERALL DIAMETER</u>	<u>WIDTH</u>	<u>HEIGHT</u>	<u>TOTAL WEIGHT</u>	<u>CONTAINER</u>	<u>REMARKS</u>
C.E./T.N.T.	Block, Mk I	14 oz.	4-1/2"	--	2-1/4"	1-7/8"	14 oz.	Metal	May be made up into a 25 ft. "chain" demolition charge.
T.N.T.	Block, Mk I	1-1/4 lb.	6"	2.4"	--	--	1-1/4 lb.	Paper	Usually inserted in a Mk I TNT Container, made of sheet steel
Amatol	Charge, Mk I	10 lb.	6.3"	6.6"	--	--	18-1/2 lb.	Mild Steel	Receives one 4 oz. primer and No. 6 detonator.
Amatol	Charge, Mk I	25 lb.	18.2"	6.6"	--	--	39-1/2 lb.	Mild Steel	Receives two 4 oz. primers and No. 6 detonators.
Amatol	Charge, Mk II	25 lb.	18.5"	6.6"	--	--	41 lb.	Mild Steel	Receives one TNT 1-1/4 lb. fitted demolition charge.
Amatol	Charge, Mk I	50 lb.	19.5"	9"	--	--	70-1/2 lb.	Mild Steel	Receives two 4 oz. primers and No. 6 detonators.

RECEIVED
 JUN 20 1945