

[54] ARMING DEVICE

2,750,888 6/1956 Wynn.....102/81.2 X

[72] Inventor: William H. Reams, Columbia, Md.

Primary Examiner—Samuel W. Engle

[73] Assignee: The United States of America as represented by the Secretary of the Navy

Attorney—M. G. Raskin, R. S. Sciascia, J. A. Cooke and R. J. Erickson

[22] Filed: Oct. 13, 1969

[21] Appl. No.: 865,707

[57] ABSTRACT

An arming device which requires both air vane rotation of a predetermined duration and target impact in sequence to complete arming. Movement of an arming rotor from an unarmed to an armed position is blocked by a plunger biased from the arming rotor path of movement but prevented from responding to the biasing action by a rotary element in the path of the plunger. The rotary element is freed for movement by the plunger only upon sensing the sequential occurrence of the air vane rotation of predetermined duration and target impact.

[52] U.S. Cl.102/78, 102/81.2
[51] Int. Cl.F42c 15/24
[58] Field of Search102/7, 71, 73-81.2

[56] References Cited

UNITED STATES PATENTS

3,450,049 6/1969 Dare.....102/80
2,609,753 9/1952 Rosenberg.....102/76
2,651,993 9/1953 Berzof et al.....102/80

4 Claims, 5 Drawing Figures

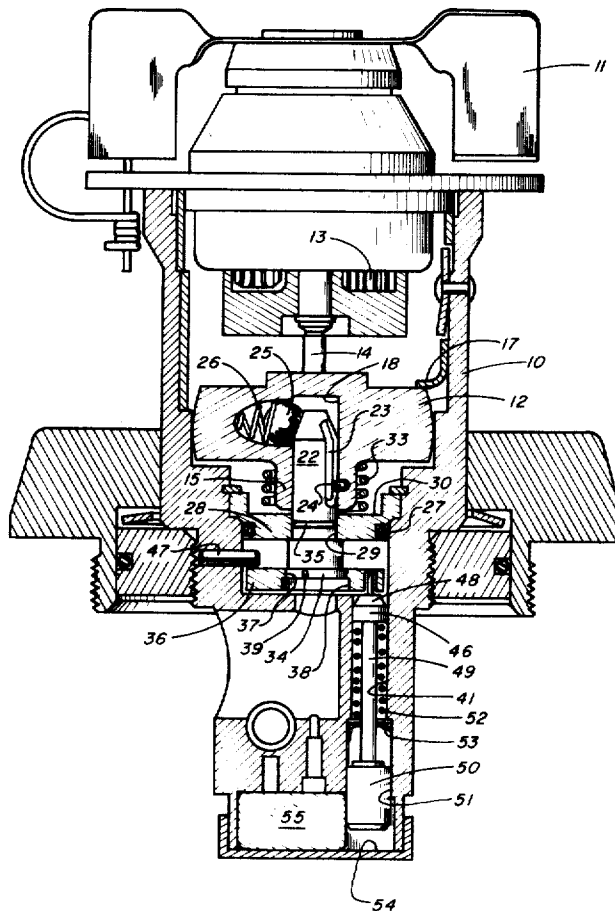

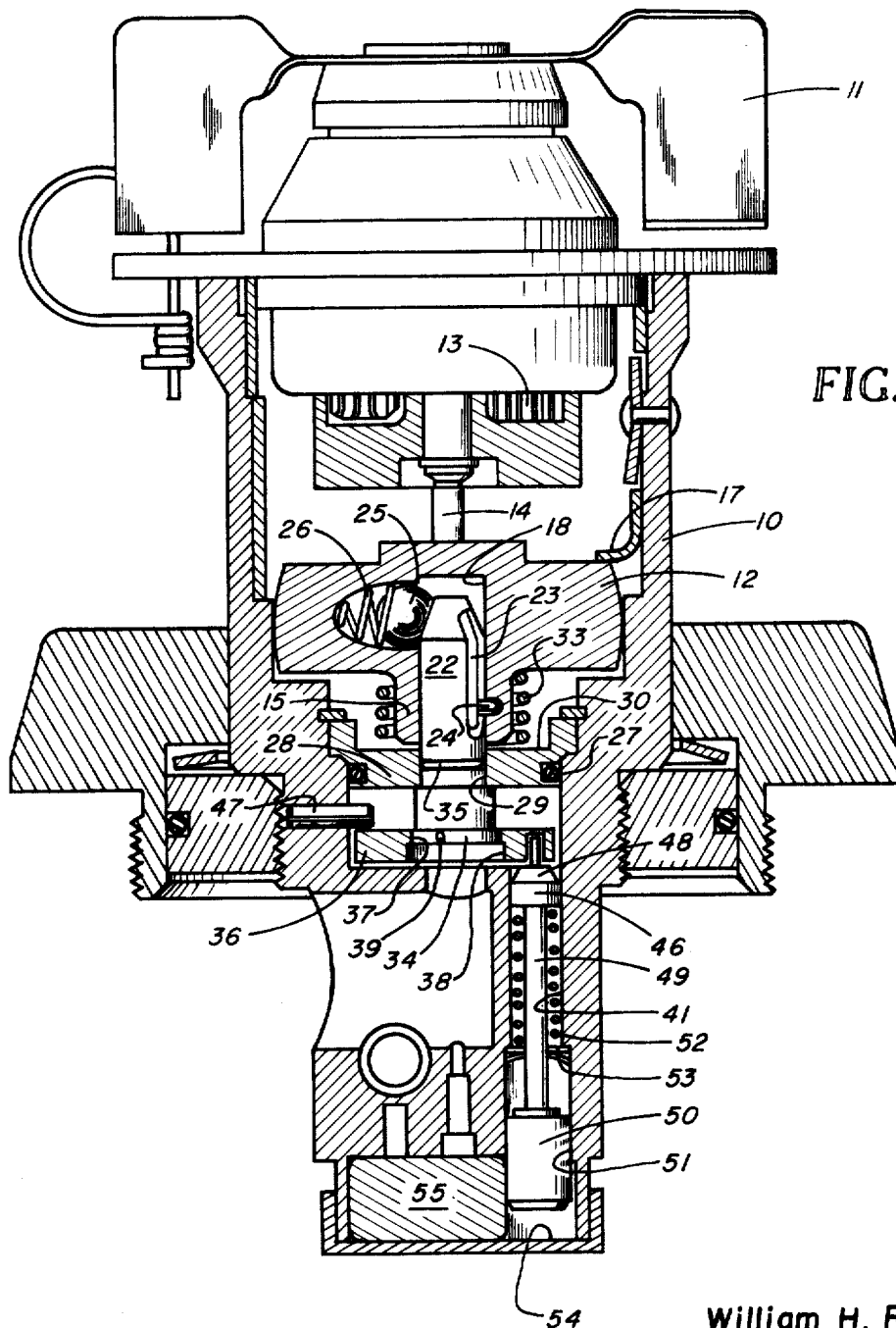

FIG. 1

William H. Reams
INVENTOR

J. O. Treanor
ATTORNEY

BY

Alvin McClelland
AGENT

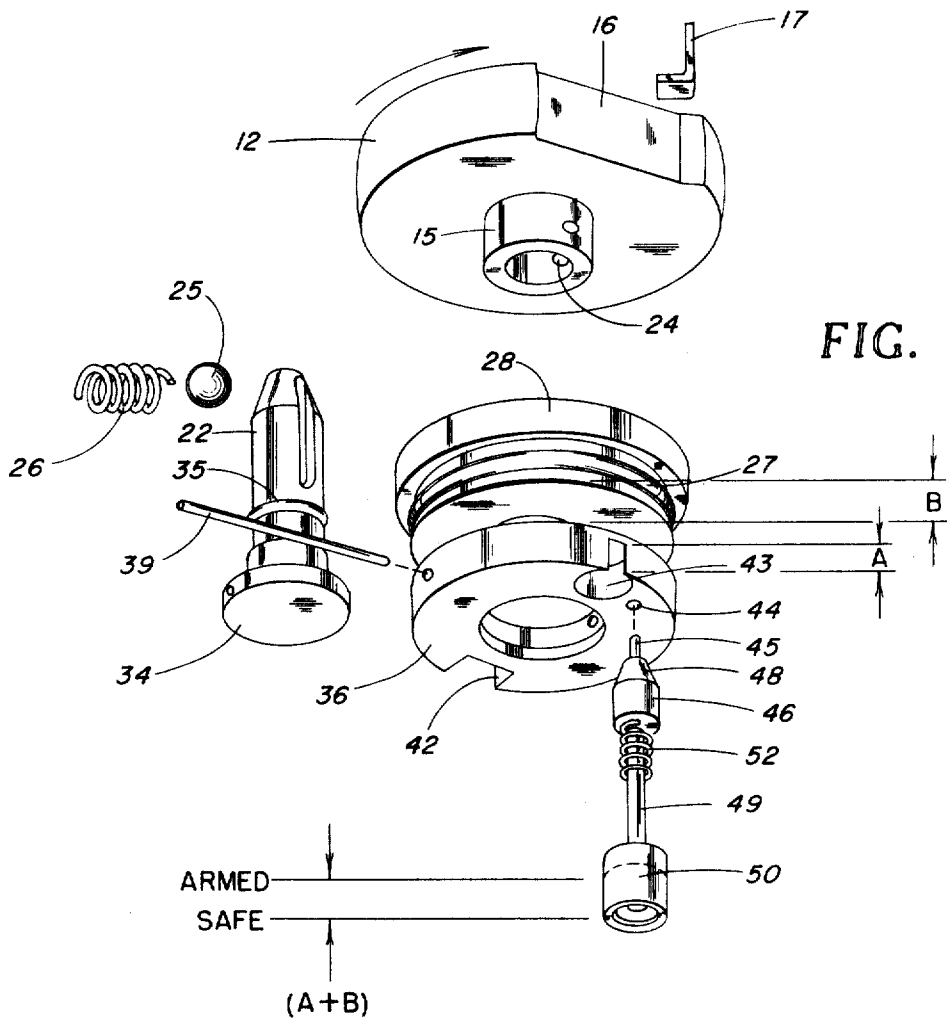

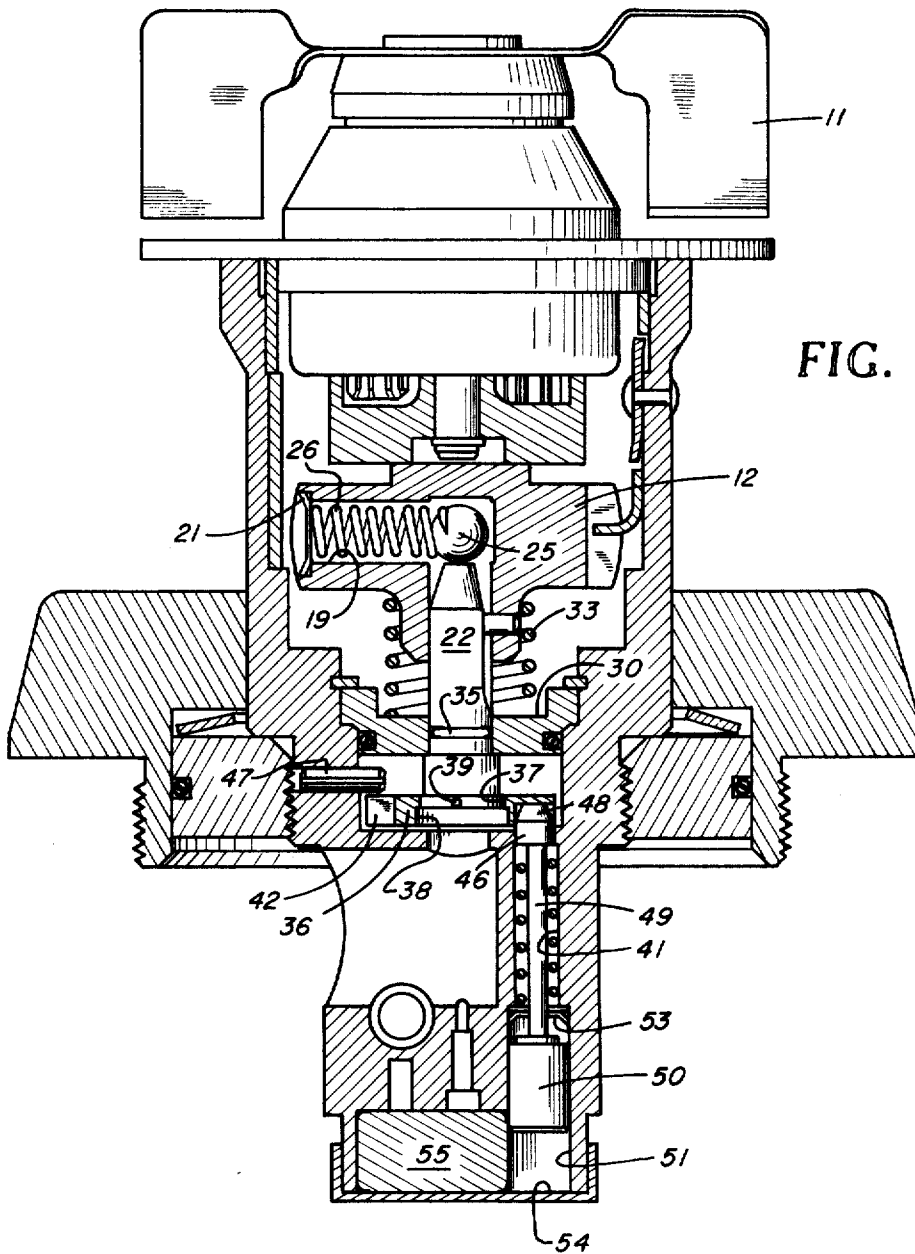

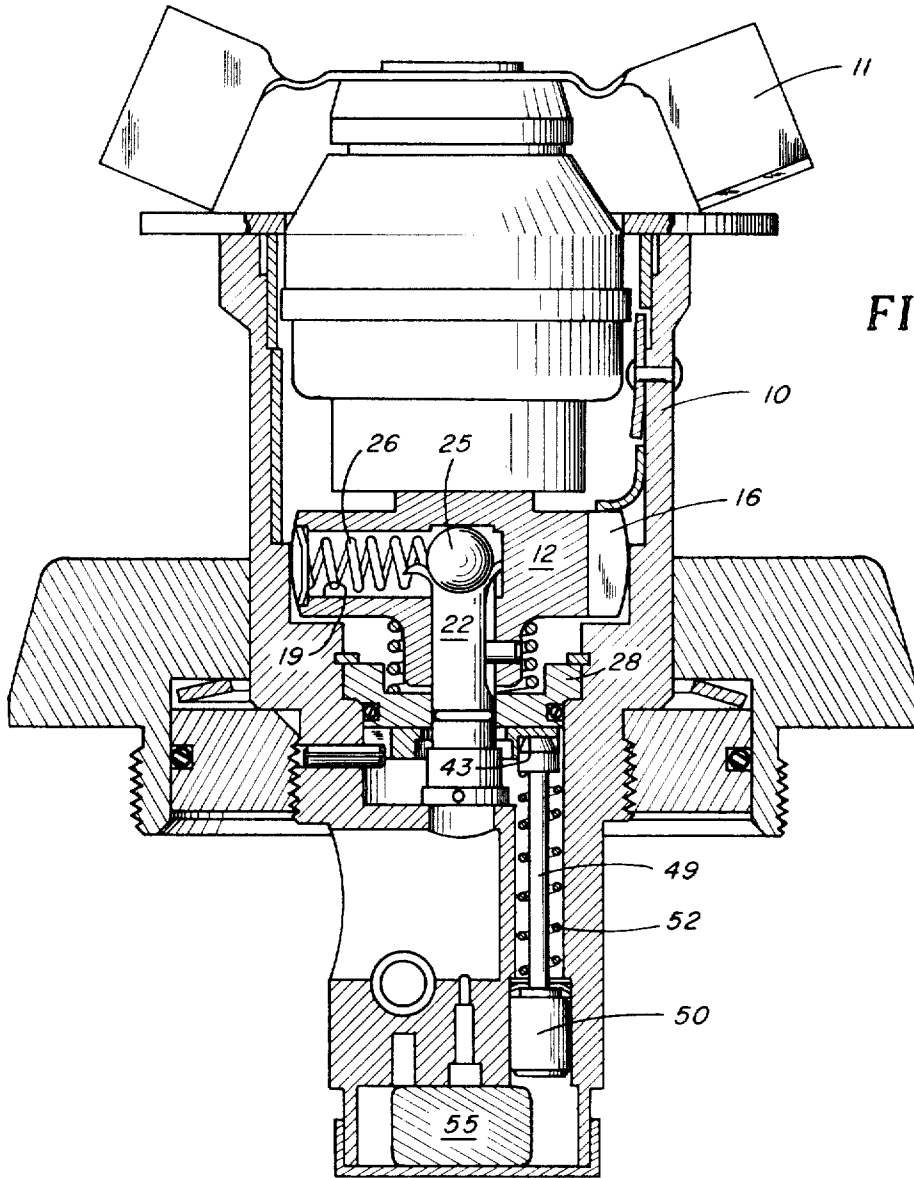
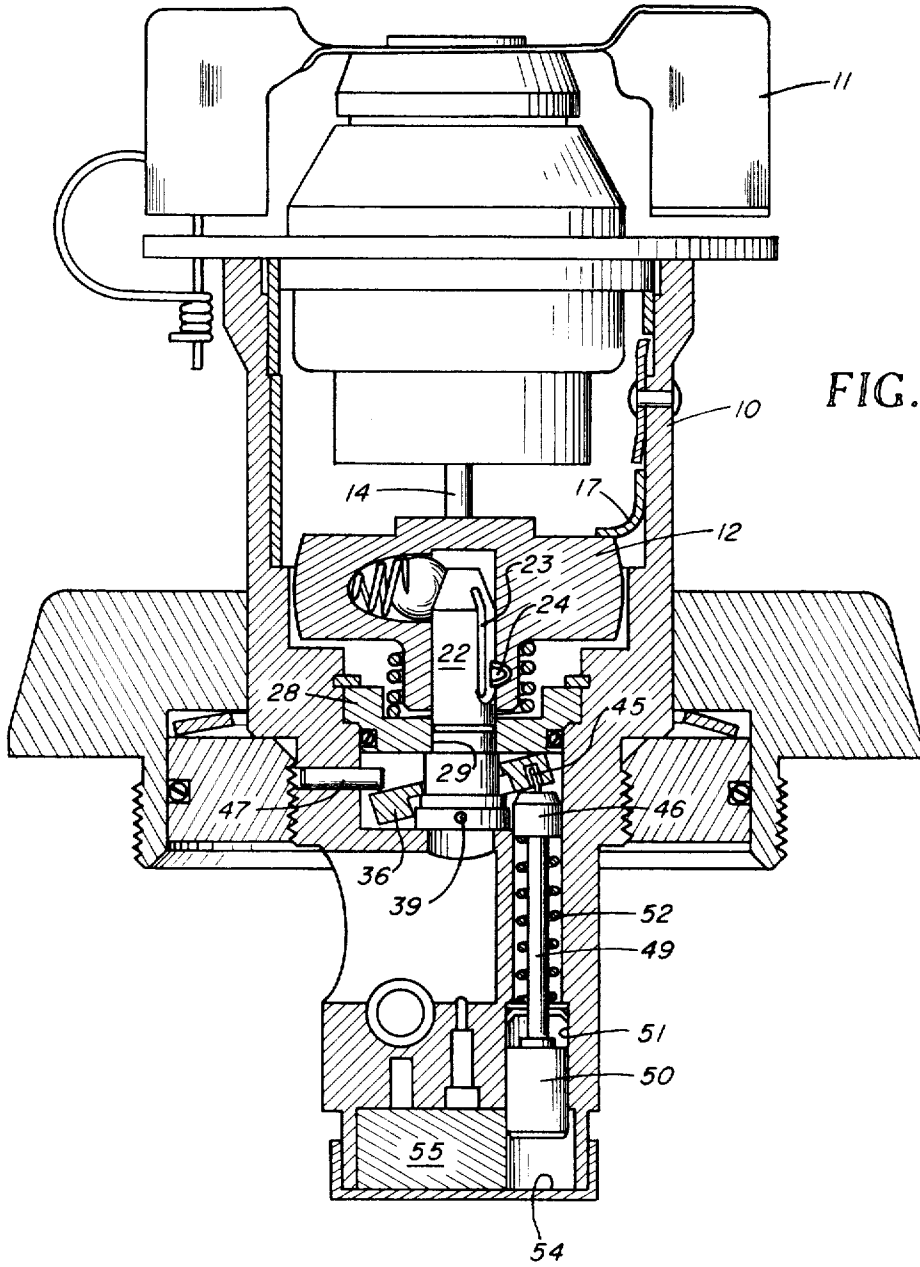

FIG. 4



ARMING DEVICE

BACKGROUND OF THE INVENTION

This invention relates generally to mechanical ordnance fuzes and more particularly to a safety and delay arming device for airborne ordnance such as a bomb, rocket or the like.

For safety reasons, it is the practice to delay the beginning of the arming cycle of a bomb, rocket or the like until it starts its travel away from the delivery vehicle to better insure safe separation of the weapon from the delivery vehicle and personnel handling or operations the same before arming is fully accomplished. Various methods have been proposed and employed for providing this arming delay and they include both mechanical and electrical fuzing. According to the existing methods, however, arming of the weapon occurs following the passage of a predetermined time interval after launching thereof and, in the case of mechanical fuzing, this is generally accomplished by propeller or air vane rotation. Although this method has been quite acceptable, it is not entirely satisfactory since the weapon still achieves an armed state far short of the target and thereby, from a standpoint of maximum safety, much nearer to the delivery vehicle and personnel than is absolutely necessary.

SUMMARY OF THE INVENTION

Accordingly, it is an object of the present invention to provide a mechanical fuze for delaying the arming of an aerial ordnance vehicle until target impact.

Another object of the present invention is to provide a mechanical fuze responsive to air flight and target impact for arming a bomb or the like.

Still another object of this invention is to provide a safety and arming device for arming a bomb or the like only after a predetermined period of time has elapsed following release from a delivery vehicle and further upon subsequent impact with a target.

The foregoing and other objects are attained by an arming device responsive to rotation of an air vane for rotating a blocking ring relative to a spring-loaded plunger to which it is connected by a shear pin for shearing the pin and permitting limited movement of the plunger into a pocket within the blocking ring, and responsive to target impact, only after such shearing of the pin and plunger movement into the blocking ring pocket, for moving a stem portion axially within the blocking ring to shear a shearing wire connected radially therebetween, whereby the blocking ring becomes freely disposed for movement with the plunger under the influence of the spring associated therewith. Upon movement of the plunger a path is cleared for a rotor element normally disposed thereagainst to rotate into an explosive train aligning position and thereby complete the arming cycle of the weapon. Accordingly, the first and second phases, or the operations responsive to air vane rotation and target impact, must occur in sequence or arming of the weapon will not occur since the out-of-line element of the explosive train is kept out-of-line until the second phase of the arming cycle is complete.

BRIEF DESCRIPTION OF THE DRAWINGS

Still other objects and many of the attendant advantages and features of this invention will be readily appreciated as the same becomes better understood by reference to the following detailed description when considered in connection with the accompanying drawings, wherein:

FIG. 1 is an elevational cross-section of an arming device constructed according to the present invention and showing the rotor in the out-of-line safe or unarmed position;

FIG. 2 is an exploded view in perspective of the components comprising the arming device of FIG. 1;

FIG. 3 is a side elevational cross-section showing the arming device of FIG. 1 after the first phase of arming has been completed and the plunger has moved into the pocket of the blocking ring;

FIG. 4 is a cross-sectional view of the arming device of FIG. 1 after the second phase of the arming cycle has been completed, thus showing the plunger removed from the path of the rotor and the rotor in the in-line or armed position; and

FIG. 5 is another cross-sectional view of the device illustrated in FIGS. 1-4 showing the plunger movement being prevented by the blocking ring upon target impact whenever some factor results in the shearing of the shear wire connecting the plunger and the blocking ring prior to completion of the first phase of the arming cycle, or whenever both phases of the arming cycle are not completed in the proper sequence.

DESCRIPTION OF A PREFERRED EMBODIMENT

Referring now to the drawings and more particularly to FIGS. 1 and 2 thereof, a fuze housing 10 adapted to be mounted on the nose or forward portion of a bomb or the like is shown with an air vane 11 disposed thereon closing the open forward end of the housing and operatively connected to a striker body 12 through a gear train 13 in the nose assembly and an output shaft 14 for rotating the striker body 12. The general configuration of the striker body 12 is substantially like that of a disc having an integral axially depending portion 15 and a notched-out surface 16 on one part of its peripheral wall. Attached to the housing 10 on the inner surface thereof is a tab or lug 17 which protrudes interiorly of the housing and contacts the upper or forwardly disposed surface of the disc-shaped striker body 12.

An axial bore 18 is provided in the striker body 12 from the end portion 15 thereof which is open interiorly to a radial bore 19 in the peripheral wall of the striker body. Disposed within the axial bore 18 of the striker body 12 is one end of an elongate stem 22 which is tapered at its extremity within the bore 18 where it is open to the radial bore 19 and has an elongate slot 23 therein for receiving a small pin 24 projecting from a radial bore in the axially depending portion 15 of the striker body 12. Thus, the stem 22 is keyed to the striker body 12 for rotation therewith by the air vane 11.

A ball 25 is disposed within the radial bore 19 in the striker body 12 between the tapered extremity of the stem 22 and a compression spring 26 held therein by a plate 21 secured to the peripheral wall of the striker body by any suitable attachment means. Displacement of the ball 25 into the axial bore 18 is thus normally prevented by the presence therein of the stem 22.

Disposed rearwardly of the striker body assembly 12 in the housing 10 in abutting relation with a shoulder formed therein and sealingly engaged therewith by an O-ring 27 compressed therebetween is a plug member 28 having a bore 29 therethrough and a counterbored recess 30 in the forward end thereof for receiving the axially depending portion 15 of the striker body 12. A coil spring 33 surrounding the striker body portion 15 and compressed between the plug 28 on one end and the lower or rearwardly disposed surface of the striker body 12 on the other end normally urges the separation along an axial line in the housing 10 of the plug and the striker body. Since rearward displacement of the plug 28 in the housing 10 is permanently prevented by its abutment with a shoulder thereof, the stored energy of the spring 33 is effective only in moving the striker body 12 away from the plug. Such movement of the striker body 12 by the spring 33 is prevented, however, in the unarmed, ready-for-delivery state of the fuze illustrated in FIG. 1 by its abutment against the housing lug 17, and may occur only upon rotation of the striker body by the air vane 11 to a position wherein the notched-out surface 16 thereon becomes aligned with the lug whereby the lug may be bypassed and displacement of the striker body 12 may be effected.

The elongated stem 22 is provided with a circular base or flange 34 at the rearward end thereof and an intermediately disposed annular groove for receiving and O-ring 35 for sealingly engaging the interior of the bore 29 in plug 28, through which the forward portion of the stem 22 is inserted in positioning the stem within the striker body. Positioned in the

housing 10 behind the plug 28 and abutting a rear wall of the housing is a blocking ring 36 having an axial through bore 37 and a counterbore 38, the former of which normally receives the base 34 of the stem 22. A small hole is drilled diametrically through each of the base 34 of the stem 22 and the blocking ring 36 and the holes in each are aligned to receive therethrough a shearing wire 39 which locks the stem and the blocking ring together such that rotation of the stem 22 through its connection with the air vane 11 and the striker body 12 is transmitted to the blocking ring 36.

A notch or channel 42 is provided in the peripheral wall of the blocking ring 36 and diametrically opposed thereof is a pocket 43 bored into the rearwardly disposed end wall. Adjacent the pocket 43 is a small hole 44 for receiving a shear pin 45 attached to one end of an elongate plunger 46. A blocking pin 47 protrudes interiorly from the housing 10 just above the blocking ring 36 and normally stands in the path of any axial movement thereof. Only upon rotation of the blocking ring 36 does the pin 47 and the notch or channel 42 become aligned whereby the path for axial movement of the blocking ring in the housing is cleared.

The plunger 46 is positioned behind the blocking ring 36 in a bore 41 in the rear wall of the housing 10 against which the blocking ring is disposed and is perpendicularly oriented with respect to the blocking ring from a point lying on a circular line concentric with the axis of the blocking ring and containing both the hole 44 and the pocket 43 therein. The plunger 46 includes a tapered portion 48 at the end thereof to which the shear pin 45 is attached, an intermediate rod portion 49 of reduced diametrical proportion, and a cylindrical portion 50 at the other end slideably disposed in a bore 51 axially aligned with the bore 41. A coil spring 52 in the bore 41 about the rod 49 and compressed between the tapered portion 48 of the plunger 46 and a shoulder plate 53 attached to the housing 10 between the bores 41 and 51 urges the plunger 46 forwardly within the housing against the blocking ring 36.

At the rear end of the housing 10 disposed within a cavity 54 open to the bore 51 is an arming rotor 55 of a conventional type having bores therethrough for providing detonating paths in an explosive train when rotated to a proper position aligning the bores therein with boosters and detonators, but normally maintained in an out-of-line position for safety purposes. Rotation of the rotor 55 to the "armed" position may be accomplished by any suitable means, such as a spring, for example, and as illustrated in FIG. 1 is prevented by the presence in the cavity 54 of the plunger 46. Thus, it may be seen that the movement of the plunger 46 out of the cavity 54, whereby the rotor 55 may be released for arming of the weapon, is normally prevented or blocked by the blocking ring 36 which lies in the path of movement thereof and which in turn is prevented from being displaced from such path of movement, as urged by the plunger 46, by a combination of factors including the blocking pin 47 and the connection of the blocking ring to the stem 22 by the shearing wire 39.

The components of the fuze assembly having been set forth and the functional arrangement thereof described in detail, the operation of the device may be readily understood from the following brief step-by-step analysis of the manner in which arming is accomplished during use.

Arming is accomplished in two phases, during which the plunger 46 must be retracted a distance of A+B, as shown in FIG. 2, to be removed from the cavity 54. The plunger moves the distance A when it drops into the pocket 43 of the blocker ring 36 during the first phase which occurs during flight and then moves the distance B when the shear wire 39 is sheared during the second phase which occurs upon impact with a target.

The first phase of arming is accomplished as the air vane 11 spins and drives the gear train 13 in the nose assembly of the fuze housing 10. The output of the gear train 13 rotates the striker body 12, which is keyed to the stem 22. Rotation of the stem 22, in turn, causes the blocker ring 36 to rotate, the two being connected by the shear wire 39. During rotation, the

blocking ring 36 shears the shear pin 45 and continues to rotate until the pocket 43 therein is aligned with the plunger 46, whereupon under the urging of spring 52 the plunger drops into the pocket and thus moves through the distance A. Simultaneously, the notch 16 in the striker body 12 aligns with the lug 17 on the housing 10 and the striker body is forced upwardly or forwardly by the compression spring 33 located between the plug 28 and the striker body until it contacts the gear housing, which is sufficient to allow the spring 26 to position the ball 25 directly over the stem 22. At this point the notch 42 on the blocking ring 36 is also aligned with the housing pin 47. The first phase of arming is thus completed.

The second phase of arming occurs at impact with a target and derives its power from the impact. Shear lugs (not shown) holding the nose assembly in position are sheared by the impact and the entire nose assembly is moved rearwardly whereupon it strikes and moves the striker body 12. This force is transmitted through the ball 25 to the stem 22 to cause shearing of the shear wire 39, whereupon the plunger 46 pushes the blocker ring 36 against the bottom or rearwardly disposed face of the plug 28, moving through a distance B. Having thus withdrawn a total distance A+B, the plunger 46 is clear of the cavity 54 and the rotor 55 moves into the "armed" position to complete the second or arming phase of the operation.

Although arming is accomplished in two phases, it should be appreciated that the rotor 55 does not move at all until both phases are completed in sequence. The shear wire 39 must be intact for the stem 22 to drive the blocking ring 36. Advance shearing of the wire 39 removes the stem connection to the blocking ring whereby subsequent rotation of the stem has no effect on arming the device. Should this occur, the blocking ring 36 is pushed through the distance B and against the plug 28 with the shear pin 45 still intact and in the hole 44, as shown in FIG. 5, whereby further rotation toward completing the arming cycle is permanently prevented. Furthermore, should crushing of the nose assembly occur before rotation, as may occur if the weapon is accidentally dropped during handling, it may or may not cause shearing of the shear wire 39 depending upon the magnitude of the crushing force. With the ball 25 off to the side of the stem 22, as it is prior to rotation, the stem is protected from the crushing force of the nose assembly by the structure of the striker body 12. Should this or any other factor cause the shear wire 39 to shear before the first rotational phase of the arming cycle occurs, however, the condition shown in FIG. 5 would exist and the device would be maintained in a "safe" condition.

In order to insure against premature withdrawal of the plunger pin 45 from the blocker ring 36 by unusual or sudden forces, a small spacing device may be inserted between the plunger portion 50 and the base of cavity 54. The device (not shown) may take on various forms and may be provided with two separate spacing elements to offer further insurance against such withdrawal after the plunger has moved into the pocket 43.

Obviously many modifications and variation of the present invention are possible in light of the above teachings. It is therefore to be understood what within the scope of the appended claims the invention may be practiced otherwise than as specifically described.

What is claimed is:

1. A delay-arming fuze for an aerial ordnance vehicle comprising
 - a movable arming member having detonating paths formed therein and normally positioned in an out-of-line position with respect to an explosive train;
 - a blocking member comprising an elongate plunger normally disposed in a first position restrainingly contacting said arming member in said out-of-line position;
 - blocking member moving means comprising,
 - a rotatable and axially movable blocking ring normally engaging said plunger on its lower surface and maintaining said plunger in said first position,

5

6

a rotatable and axially movable striker member coupled to said blocking ring through an elongate stem, said stem connected at one end to said blocking ring by a shear member and connected at the other end to said striker member by a pin projecting into a first bore formed in said striker member cooperating with an elongate longitudinal slot formed in said stem, and means for rotating said striker member, whereby rotation of said striker member causes said blocking ring to rotate.

2. A delay arming fuze as recited in claim 1 wherein said blocking ring lower surface has formed therein a recessed pocket near the periphery thereof and said first position of said plunger is defined by said pocket being angularly displaced from said plunger, said plunger engaging the blocking ring lower surface, and said second position defined by said pocket being axially aligned with said plunger to receive an end portion of said plunger,

whereby upon rotation of said blocking ring, said pocket becomes axially aligned with said plunger and said

plunger becomes seated in said pocket thereby moving to said second position.

3. A delay arming fuze as recited in claim 2 wherein said striker member is biased toward a raised position and is normally prevented from axial movement to said raised position by a fixed lug in contact therewith;

said striker member having formed in the peripheral wall thereof a notched-out surface,

whereby upon rotation of said striker member, said lug aligns with said notch and said striker member moves upwardly simultaneous with said plunger becoming seated in said pocket.

4. A delay arming fuze as recited in claim 3 wherein said striker member has a spring biased ball positioned within a second bore formed therein and being normally prevented by said stem from entering said first striker member bore and adapted to enter therein upon said striker member attaining said raised position.

* * * * *

25

30

35

40

45

50

55

60

65

70

75