

TM 9-229

WAR DEPARTMENT TECHNICAL MANUAL

20-MM
AUTOMATIC
GUN M3

3146

This manual supersedes TM 9-229, 1 June 1944, including Errata Sheet, and so much of TB ORD 330, 21 November 1945, and TB ORD 340, 26 March 1947, as pertains to matériel covered in this manual.

8/

20-MM AUTOMATIC GUN M3



WAR DEPARTMENT

JUNE 1947

United States Government Printing Office

Washington : 1947

For sale by the Superintendent of Documents, U. S. Government Printing Office,
Washington 25, D. C. - Price 50 cents

WAR DEPARTMENT

WASHINGTON 25, D. C., 20 June 1947

TM 9-229, 20-mm Automatic Gun M3, is published for the information and guidance of all concerned.

The information in this manual is correct as of 18 March 1947.

[A. G. 300.7 (11 Jan 45)]

BY ORDER OF THE SECRETARY OF WAR:

OFFICIAL:

EDWARD F. WITSELL

Major General

The Adjutant General

DWIGHT D. EISENHOWER

Chief of Staff

DISTRIBUTION:

AAF (5); AGF (2); T (10); Dept (5); AAF Maj Comds (2);
Arm & Sv Bd (1); Tech Sv (2); FC (1); BU (1); PE (Ord O)
(5); Dist 9 (3); Establishments 9 (3); Gen & Sp Sv Sch (5);
A (ZI) (25), Overseas (3); CHQ (2); D (2); AF (3); G (1);
S (1); LS (1); T/O & E, 9-7 (1); 9-315 (1); 9-319 (1).

For explanation of distribution formula, see TM 38-405.

CONTENTS

PART ONE. INTRODUCTION.

	Paragraphs	Page
<i>Sect:</i> I. General.....	1-2	1
II. Description and data.....	3-5	1

PART TWO. OPERATING INSTRUCTIONS.

<i>Section</i> III. General.....	6	6
IV. Service upon receipt of equipment.....	7-9	6
V. Controls.....	10	7
VI. Operation under usual conditions.....	11-16	8
VII. Operation under unusual conditions.....	17-21	25
VIII. Demolition to prevent enemy use.....	22-25	26

PART THREE. MAINTENANCE INSTRUCTIONS.

<i>Section</i> IX. General.....	26-27	28
X. Spare parts, tools, and equipment.....	28-29	28
XI. Use and maintenance of linking machines M4 and M13.....	30-32	42
XII. Lubrication.....	33-36	48
XIII. Preventive maintenance services.....	37-40	50
XIV. General ordnance maintenance.....	41-42	54
XV. Cyclic functioning of weapons.....	43-51	58
XVI. Malfunctions and corrections.....	52-58	67
XVII. Cradle group.....	59-61	70
XVIII. Tube and receiver group.....	62-66	73
XIX. Breechblock group.....	67-71	88
XX. Gas cylinder sleeve group.....	72-75	97
XXI. Recoil group.....	76-77	99
XXII. 20-mm feed mechanism AN-M2.....	78-82	102
XXIII. 20-mm feed mechanism M3.....	83-89	129
XXIV. 20-mm pneumatic charger M4.....	90-94	178
XXV. 20-mm hydraulic charger M7.....	95-99	187
XXVI. 20-mm hydraulic charger M5.....	100-104	192
XXVII. 20-mm manual charger M6.....	105-108	202
XXVIII. 20-mm electric trigger AN-M1A1.....	109-113	209
XXIX. 20-mm electric trigger AN-M4.....	114-118	214
XXX. 20-mm electric heater M1.....	119-121	217

PART FOUR. AUXILIARY EQUIPMENT.

<i>Section</i> XXXI. General.....	122	221
XXXII. Ammunition.....	123-132	221

APPENDIX I. STORAGE AND SHIPMENT.....	231
---------------------------------------	-----

II. REFERENCES.....	236
---------------------	-----

INDEX.....	239
------------	-----

P

This manual supersedes TM 9-229, 1 June 1944, including Errata Sheet, and so much of TB ORD 330, 21 November 1945, and TB ORD 340, 26 March 1947, as pertains to matériel covered in this manual.

PART ONE INTRODUCTION

Section I. GENERAL

1. Scope

This manual is published for the information and guidance of the using arms and ordnance maintenance personnel of the Army. It contains instructions required for the identification, use, care, inspection, maintenance, and rebuild of the 20-mm automatic gun M3 and of the equipment used therewith.

2. Records

a. FIELD REPORT OF ACCIDENTS. When an accident involving the use of ammunition occurs during practice, the incident will be reported as prescribed in AR 750-10 by the ordnance officer under whose supervision the ammunition is maintained or issued. Where practicable, reports covering malfunctions of ammunition in combat will be made by Army personnel to the Chief of Ordnance giving the type of malfunction, the type of ammunition, the lot number, and the condition under which fired.

b. UNSATISFACTORY REPORT. Suggestions for improvement in manufacture, design, maintenance, safety, and efficiency of operation, prompted by chronic failure or malfunction of the weapon, spare parts, or equipment, should be reported by Army personnel on WD AAF Form 54 (Unsatisfactory Report). If WD AAF Form 54 is not available, one may be improvised by referring to sample in TM 38-650. These forms will also be used for reporting complaints on the application or effect of prescribed petroleum fuels, lubricants, and preserving materials, and when so used, will contain identifying details on both the products and the associated equipment. Army personnel should forward the report to: Commanding General, Headquarters, Air Service Command, Patterson Field, Fairfield, Ohio.

Section II. DESCRIPTION AND DATA

3. Description

a. GENERAL. The 20-mm automatic gun M3 (figs. 1 and 2) is a combination blow-back and gas-operated aircraft weapon. The gun is air-cooled and has a cyclic rate of fire of from 650 to 800 rounds per minute. It is designed for mounting as a fixed gun in the wing

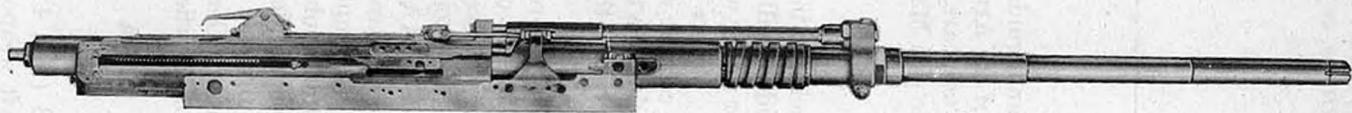

Figure 1. 20-mm automatic gun M3—Right side view.

RA PD 108025

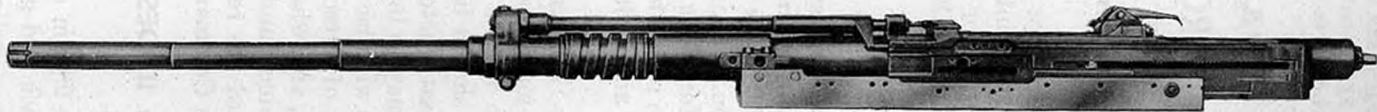

Figure 2. 20-mm automatic gun M3—Left side view.

RA PD 108026

or fuselage of an airplane. It may also be mounted as a flexible gun in a turret. The gun can be fed from either right or left side.

b. DIFFERENCES IN MODELS. (1) The differences between the 20-mm automatic guns AN-M2 and M3 which affect troop use are as follows:

20-mm Automatic Gun M3

Right- or left-side charging, using following chargers:

- 20-mm manual charger M6
- 20-mm pneumatic charger M4
- 20-mm hydraulic charger M7
- 20-mm hydraulic charger M5

Left- or right-side feeding, using 20-mm feed mechanisms AN-M2, M3, and AN-M1A1.

20-mm electric triggers AN-M1A1 and AN-M4.

20-mm Automatic Gun AN-M2

Right-side charging only, using following chargers:

- 20-mm manual charger M2.
- 20-mm hydraulic charger M1.

Left- or right-side feeding, using 20-mm feed mechanism M3, AN-M1A1.

Manual firing, using 20-mm sear mechanism M1; 20-mm electric trigger AN-M1.

(2) The differences between the 20-mm automatic guns AN-M2 and M3 which affect ordnance maintenance are as follows:

20-mm Automatic Gun M3

Gas cylinder bracket can be removed for replacement or for cleaning.

Rear buffer is lubricated at assembly; it is not to be disassembled but replaced as a unit.

Length of tube is 52.5 inches.

20-mm Automatic Gun AN-M2

Gas cylinder bracket is shrunk on and pinned in place.

Rear buffer can be disassembled for cleaning or replacement.

Length of tube is 67.5 inches.

4. Identification Information

a. SERIAL NUMBERS. The serial numbers identified below are required for records concerning the components of this matériel.

Note. The serial numbers of the gun and tube will usually be different. The serial number on the receiver is the actual number of the gun. Any reports sent in should, however, give both serial numbers.



Figure 3. Location of serial number of gun.

RA PD 93923

- b. GUN. The gun serial number is stamped on the receiver.
 c. TUBE. The tube serial number is stamped on the tube just ahead of the gas cylinder bracket.

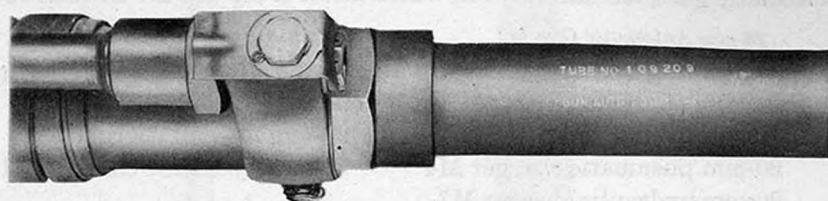

RA PD 93924

Figure 4. Location of serial number of gun tube.

5. Data

a. GUN.

Weight of gun, including cradle.....	99.5 lb.
Over-all length of gun.....	77.7 in.
Weight of the tube.....	26.2 lb.
Length of the tube.....	52.5 in.
Muzzle velocity.....	2,730 ft per sec.
Rate of fire.....	650 to 800 rounds per min.

Rifling:

Number of grooves.....	9.
Depth of grooves.....	0.015 in.
Width of grooves.....	0.205 in.
Width of lands.....	0.068 in.
Twist, uniform, right-hand, slope.....	7 deg.
Length.....	48.06 in.
Travel of projectile in tube.....	48.66 in.

b. FEED MECHANISM. (1) 20-mm feed mechanism AN-M2.

Weight.....	13 lb.
Over-all length.....	10.2 in.

Maximum extension:

Above centerline of gun (LH and RH feed).....	5.5 in.
To right of centerline of gun (RH feed).....	3.12 in.
To left of centerline of gun (RH feed).....	3.5 in.
To left of centerline of gun (LH feed).....	3.12 in.
To right of centerline of gun (LH feed).....	3.5 in.

(2) 20-mm feed mechanism M3.

Weight.....	15.5 lb.
Over-all length.....	18 in.

Maximum extension:

Above centerline of gun (LH and RH feed).....	4.81 in.
To right of centerline of gun (RH feed).....	3.87 in.
To left of centerline of gun (RH feed).....	4.18 in.

Maximum extension—Continued

To left of centerline of gun (LH feed)	3.87 in.
To right of centerline of gun (LH feed)	4.18 in.
Motor	24 v, dc, 7,600 rpm, 4.6 lb-in. torque.
c. ELECTRIC TRIGGERS. (1) <i>20-mm electric trigger AN-M1A1.</i>	
Weight	5 lb.
Volts	24 v, dc.
Pull	(approx) 70 lb.
(2) <i>20-mm electric trigger AN-M4.</i>	
Weight	3.5 lb.
Volts	24 v, dc.
Pull	(approx) 70 lb.
d. CHARGERS. (1) <i>20-mm pneumatic charger M4.</i>	
Weight	2.5 lb.
Length	23.2 in.
Operating pressure	800 lb.
(2) <i>20-mm manual charger M6.</i>	
Weight	3 lb.
Length	19.2 in.
(3) <i>20-mm hydraulic charger M5.</i>	
Weight	4.3 lb.
Length	26.5 in.
Operating pressures	1,200 lb.
(4) <i>20-mm hydraulic charger M7.</i>	
Weight	2.8 lb.
Length	24 in.
Operating pressures	1,000 lb.
e. 20-MM ELECTRIC HEATER M1.	
Weight	1 lb.
Power	200 w.
Volts	24 v, dc.

PART TWO

OPERATING INSTRUCTIONS

Section III. GENERAL

6. Scope

Part two contains information for the guidance of the personnel responsible for the operation of this equipment. It contains information on the operation of the equipment with the description and location of the controls.

Section IV. SERVICE UPON RECEIPT OF EQUIPMENT

7. General

a. Upon receipt of new or used equipment, it is the responsibility of the officer in charge to ascertain whether it is complete and in sound operating condition. A record should be made of any missing parts and any malfunctions, and any such conditions should be corrected as quickly as possible.

b. Attention should be given to small and minor parts, as these are more likely to become lost and may seriously affect the proper functioning of the matériel.

c. The matériel should be prepared for service in accordance with instructions given in paragraph 8 or 9.

8. New Equipment

a. If the gun is coated with rust-preventive compound, the compound must be removed prior to inspection as follows:

(1) The gun should be disassembled as required and all parts cleaned with rifle-bore cleaner.

Caution: Do not dip recoil housing assembly, rear buffer, or charger (except manual charger) in the cleaning solution. Swab with *cloth* dipped in cleaning solution, allow to dry, and then wipe with a clean *lightly oiled cloth*.

(2) Clean bore with waste to remove bulk of rust-preventive compound. Then saturate a cloth in dry-cleaning solvent and run through the bore until the rust-preventive compound has been entirely removed.

b. Inspect for any broken or missing parts.

c. Inspect all operating parts for smoothness of operation.

- d. Check functioning of electric triggers.
- e. Check functioning of chargers.
- f. Check functioning of feed mechanisms.
- g. Check spare parts and equipment with WD Supply Catalog ORD 7 SNL A-47.
- h. Inspect tools and equipment, listed in section X, for completeness and condition.

9. Used Equipment

The services required to insure proper operation of the matériel are identical to those given in paragraph 8, except for the following addition: Check to determine whether or not all Modification Work Orders have been applied. (See par. 38b.)

Section V. CONTROLS

10. Controls

a. CONTROLS FOR CHARGING GUN. (1) The 20-mm manual charger M6 is operated by pulling the charger cable (fig. 198) to the rear as far as it will go and then releasing it.

(2) The 20-mm pneumatic charger M4 is operated by first opening the valve of the storage cylinder containing the compressed air or gas, and then either by moving the handle of the two-way manually operated valve and releasing it after not less than a 1-second delay (fig. 5),

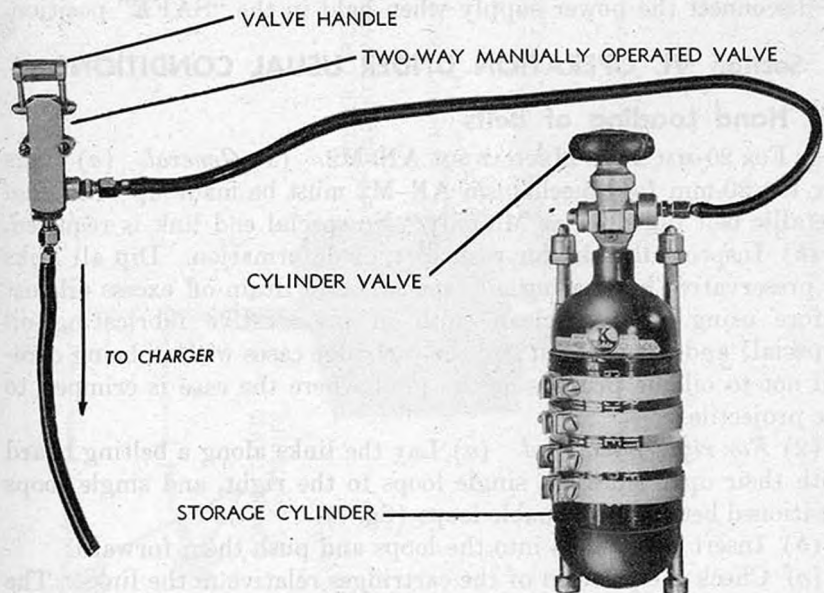

Figure 5. Controls for 20-mm pneumatic charger M4.

RA PD 94030

or by closing the valve switch of the solenoid controlled valve and breaking the circuit by means of another switch.

(3) The 20-mm hydraulic chargers M5 and M7 are operated by moving the handle of the pump valve and releasing it after not less than a 1-second delay.

b. **FIRING SWITCH FOR GUNS EQUIPPED WITH 20-MM FEED MECHANISM AN-M2.** The firing switch for use with guns equipped with a 20-mm feed mechanism AN-M2 is usually located on the control wheel in the pilot's compartment. When the switch is closed, the solenoid of the electric trigger is energized, which causes the sear to be released, thus allowing the breech block to move forward to feed and fire the round.

c. **LOADING AND FIRING CONTROLS FOR GUN EQUIPPED WITH 20-MM FEED MECHANISM M3.** (1) The power circuit breaker switch (fig. 6) is used to connect the power supply to the electric motor and electric trigger.

(2) The loading switch (fig. 6) is used to energize the electric motor and operate the feed mechanism. It is operated by holding it in the "LOAD" position (fig. 6).

(3) The firing switch (fig. 6), when closed, energizes the solenoid of the electric trigger, which causes the sear to be released, thus allowing the breech block to move forward to feed and fire the round.

(4) The fire interrupter switch (fig. 6) is used to connect the power supply to the electric trigger when held in the "FIRE" position and to disconnect the power supply when held in the "SAFE" position.

Section VI. OPERATION UNDER USUAL CONDITIONS

11. Hand Loading of Belts

a. **FOR 20-MM FEED MECHANISM AN-M2.** (1) *General.* (a) Belts for the 20-mm feed mechanism AN-M2 must be made up of 20-mm metallic belt links M7 or M8 only. No special end link is required.

(b) Inspect all links for rust, dirt, or deformation. Dip all links in preservative lubricating oil (special) and drain off excess oil just before using. Dip a clean cloth in preservative lubricating oil (special) and wring it out; oil the cartridge cases with it, being careful not to oil the primers or the joint where the case is crimped to the projectile.

(2) *For right-hand feed.* (a) Lay the links along a belting board with their open sides up, single loops to the right, and single loops positioned between the double loops (fig. 7).

(b) Insert the rounds into the loops and push them forward.

(c) Check the position of the cartridges relative to the links. The distance from the base of the cartridge case to the rear edge of the double loop should be $2\frac{9}{32}$ inches $\pm \frac{1}{16}$ (fig. 7).

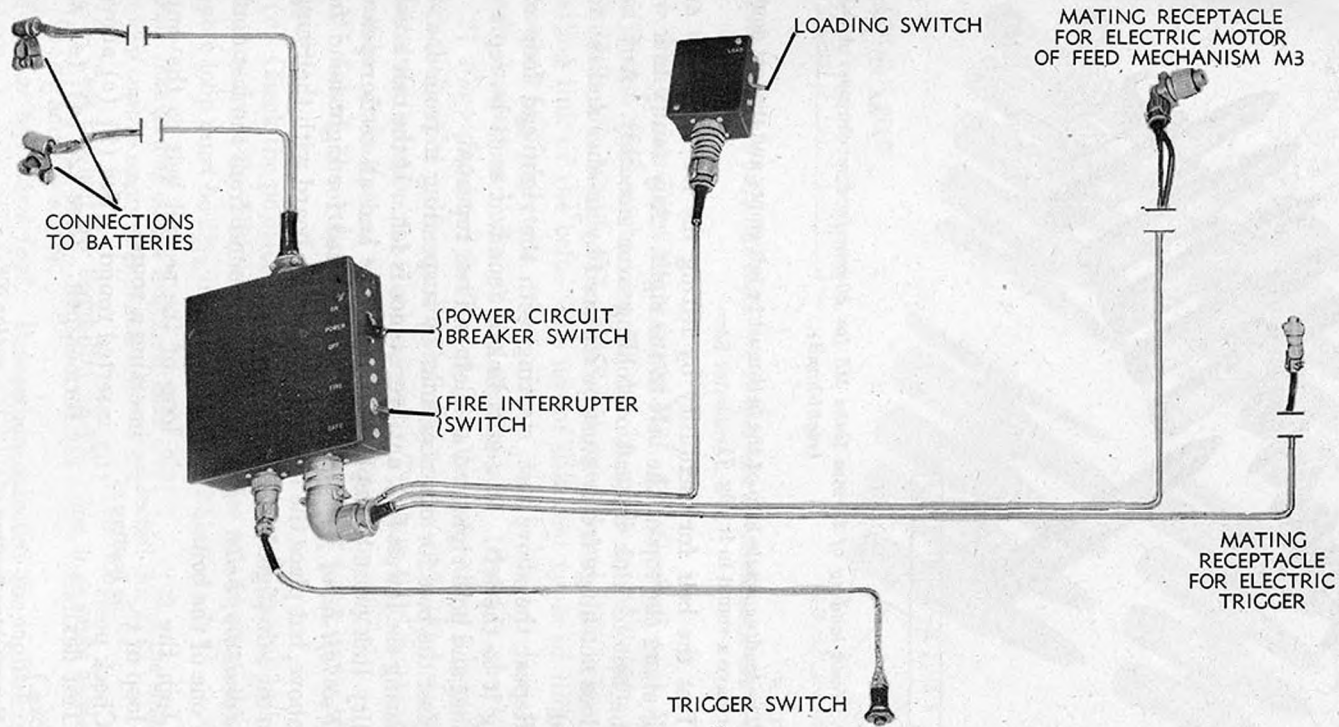
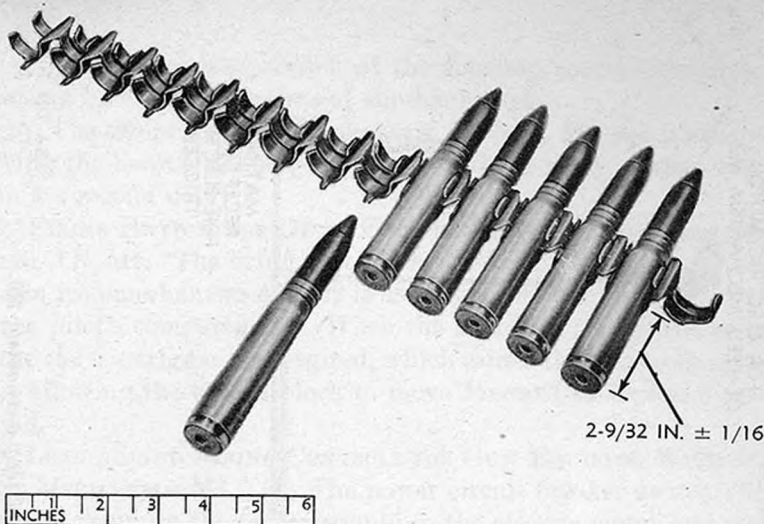

Figure 6. Controls for firing of gun equipped with 20-mm feed mechanism M3.

RA PD 108062



RA PD 108039

Figure 7. Hand-loading of 20-mm links M8 for 20-mm feed mechanism AN-M2 (right-hand).

Note. The leading single loop of the belt must be left empty and the last double loop must have a round in it (fig. 7).

(d) Test the belt for flexibility by lifting the left end loop and drawing along the top of the belt to the right. Any faulty link will cause the belt to kink instead of folding over smoothly. Any link which does not hinge freely must be replaced by another and the test repeated.

(e) Repeat the above test, starting with the right end loop and drawing it to the left. If a stiff link is found, it must be replaced by another and both right end and left end test repeated.

(f) Test the belt for oversize links by suspending it from one end and twisting the lowest link until resistance is felt. If the belt breaks, the faulty link must be replaced by another and all tests repeated.

(3) *For left-hand feed.* Proceed as directed for right-hand feed in (2) above, but place the links on the belting board with their single loops to the left (figs. 7 and 8).

(4) *Joining of belts.* (a) Remove the round from the last double loop of one of the belts.

(b) Join the empty single loop of the second belt to the empty double loop of the first belt by inserting a round.

(c) Check position of newly inserted round. (See (2) (c) above.)

(d) Test flexibility of newly formed belt. (See (2) (d), (e), and (f) above.)

Note. For machine loading of belts, see section XI.

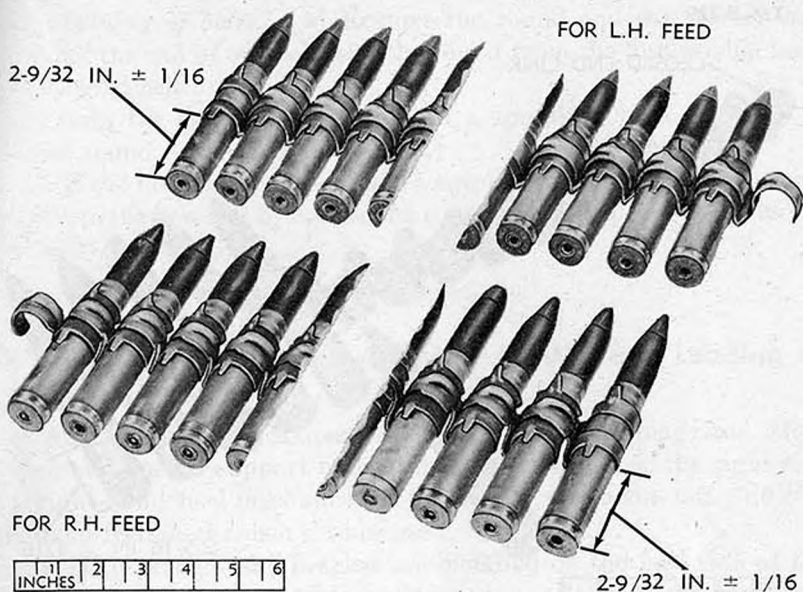

RA PD 108040

Figure 8. Loaded belts (M8 links) for 20-mm feed mechanism AN-M2 (right-hand and left-hand).

b. FOR 20-MM FEED MECHANISM M3. (1) *General.* (a) Belts for the 20-mm feed mechanism M3 can be made up of 20-mm metallic belt links M3, M3A1, M7, or M8. A special end link is used as the trailing link of the belt. The use of different types of links in the same belt is prohibited.

(b) Inspect and oil the links and rounds. (See (1) above.)

(2) *For right-hand feed.* (a) Lay the links along a belting board with their open sides up, double loops to the right, and single loops positioned between the double loops. The last link on the left end must be of the special type with the closed loop (fig. 9).

(b) Insert the rounds into the loops and push them forward (fig. 9).

(c) Check the position of the cartridges relative to the links. The distance from the base of the cartridge case to the rear edge of the double loop must be $2\frac{5}{16}$ inches \pm $\frac{1}{16}$ (fig. 9).

Note. The leading double loop must have a round in it, and the single closed end loop must be empty (figs. 9 and 10).

(d) Test the belt for flexibility and for oversize links as described in (2) (d) and (f) above.

(3) *For left-hand feed.* Proceed as directed for right-hand feed in b(2) above, but place the links with double loops to the left, and place the special end link on the right end (figs. 9 and 10).

TM 9-229

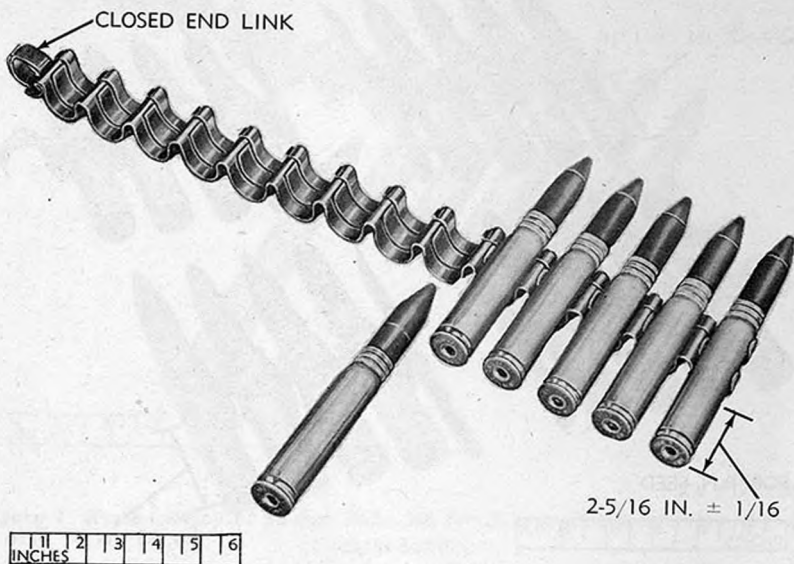

RA PD 93975

Figure 9. Loading 20-mm belt links M3 for 20-mm feed mechanism M3 (right-hand).

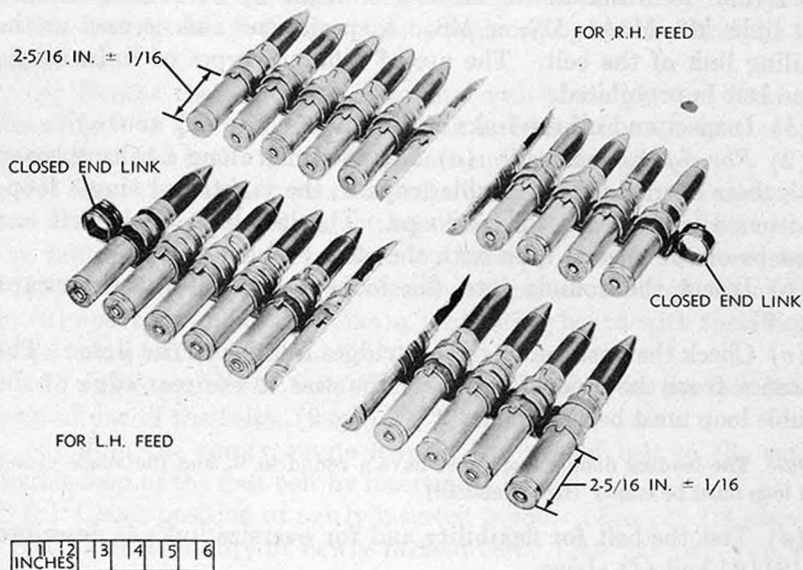

RA PD 93976

Figure 10. Loaded belts (M7 links) for 20-mm feed mechanism M3 (right-hand and left-hand).

(4) *Joining of belts.* (a) Remove the round and the special end link from the end of one belt, and the round from the first double loop of the second belt.

(b) Join the two belts by means of a round. Check position of inserted round. (See *b(2)(c)* above.)

(c) If the new belt does not have a special end link, join the special end link to the new belt by means of a round. Check position of round. (See *b(2)(c)* above.)

Note. For machine loading of belts, see section XI.

12. Installation of Feed Mechanism AN-M2 and Loading of Gun

a. ADJUSTMENT OF MAGAZINE SLIDE. (1) The magazine slide anchor and anchor support bracket *must* be installed on the right side if a right-hand feed mechanism is to be used, or on the left side if a left-hand feed mechanism is to be used.

(2) If the anchor and bracket are installed on the feed side of the gun, adjust the magazine slide anchor nuts so that the engraved lines on the receiver aline with the engraved lines on the magazine slide (fig. 11). This adjustment must be made when the gun is cold. Make certain that nuts on anchors are tight.

(3) If the anchor and bracket are not on the feed side of the gun, proceed as follows:

(a) Remove the cotter pin, anchor screw lock washer, and anchor securing screw (fig. 11). Unscrew the two magazine slide anchor front nuts (fig. 11), and remove the anchor.

(b) Cut and remove the lock wire and unscrew the two anchor support bracket screws (fig. 11).

(c) Secure the anchor to the magazine slide on the feed side of the gun, using screw, lock washer, and cotter pin. The threaded portion of anchor should point toward muzzle of gun (fig. 11).

(d) Position the bracket on the anchor, between the gun tube and inside wall of cradle, with the bulging side of the bracket adjacent to tube (fig. 11).

(e) Secure the bracket to the cradle by means of the two screws and then lock-wire the screws.

(f) Screw the two front nuts on the anchor and adjust the nuts so that the engraved lines on slide and receiver aline.

b. INSTALLATION OF OPERATING LEVER BRACKET. (1) Attach the operating lever bracket by means of its dowel pin to the right side of the receiver if a right-hand feed mechanism is to be used, or to the left side if a left-hand feed mechanism is to be used.

(2) Secure the bracket with the two bracket screws and lock-wire the screws (fig. 11).

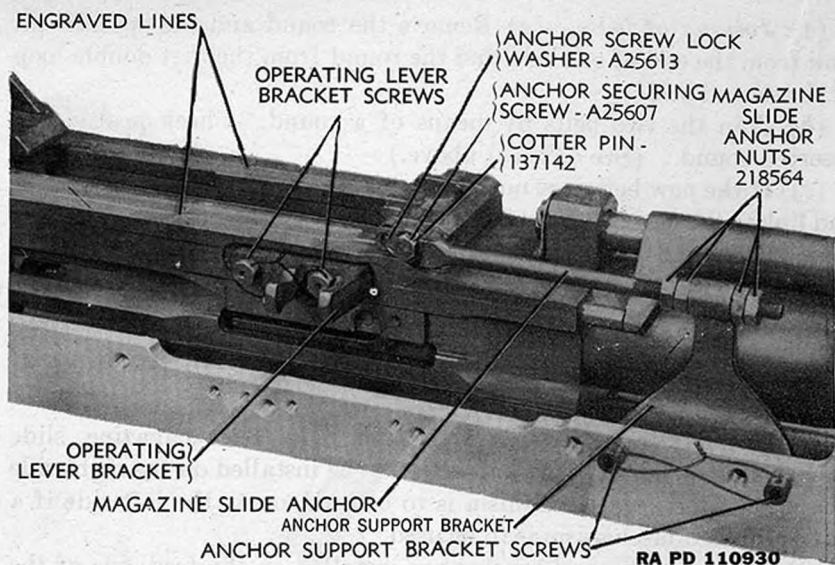
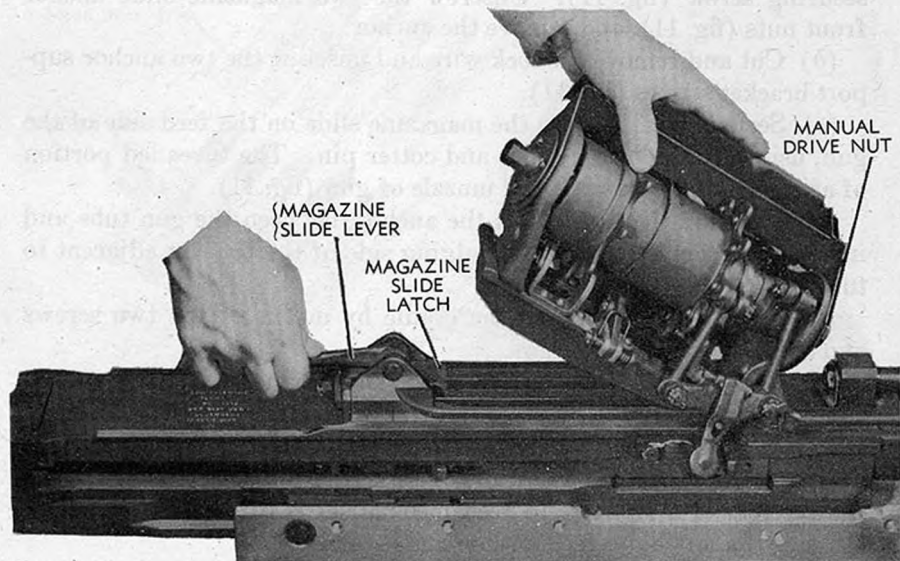

Figure 11. Adjustment of magazine slide and installation of operating lever bracket.

c. INSTALLATION OF FEED MECHANISM. (1) Hold the feed mechanism above the magazine slide with the manual drive nut (fig. 12) pointing toward the muzzle.

(2) Carefully lower the front end of the mechanism so that the mouth enters the opening of the magazine slide, and push the mecha-



RA PD 93966

Figure 12. Installation of 20-mm feed mechanism AN-M2.

nism forward until the transverse lug at the front of the mouth engages the hook-shaped projections at the front of the magazine slide (fig. 12).

(3) Lift the magazine slide lever and push the rear end of the feed mechanism down into place past the latch, and release the lever (fig. 12).

(4) Push the operating lever of the feed mechanism into position between the lugs of the operating lever bracket (fig. 13), making certain that the operating lever is latched to the operating crank.

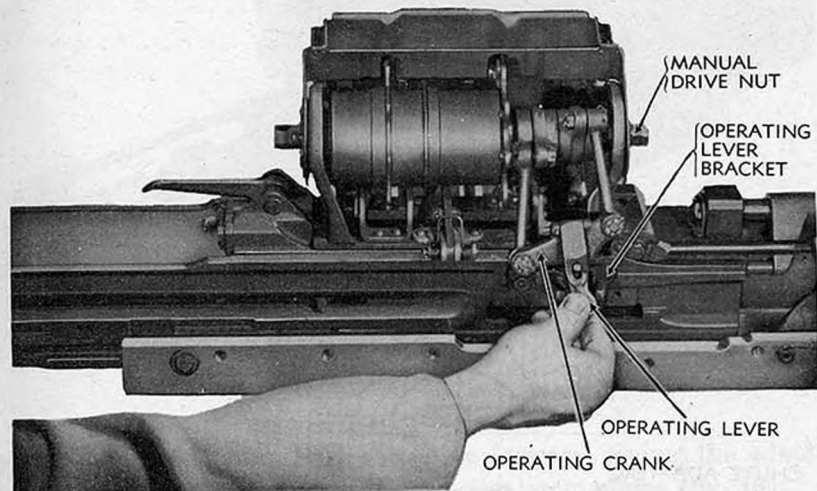

RA PD 93972

Figure 13. Positioning the operating lever of 20-mm feed mechanism AN-M2.

d. **INSTALLATION OF FEED MECHANISM COVERS.** Ammunition can be fed into the feed mechanism at an angle of 75° above the horizontal through the feed chute adapter on the drive side of the feed mechanism. The mechanism can be fitted with feed covers to give ammunition entrance angles of from 55° above horizontal to 47° below horizontal on the drive side of the feed mechanism (fig. 14).

(2) To install a feed mechanism cover, unlatch the adapter from the feed frame and swing the adapter up. Assemble the feed cover to the mechanism and latch the feed cover to the feed frame; then latch the adapter to the cover (fig. 15).

Note: The covers for the right-hand and left-hand feed mechanisms are different. When the proper cover is installed, the contours of the cover and feed chute adapter will match (fig. 16). The installation of the wrong cover will result in a failure to feed. (These feed covers are air force equipment and are not issued by the Ordnance Department.)

e. **LOADING GUN.** (1) Hold the end of the feed chute marked "GUN END" near the feed chute adapter so that the open side of the chute is up and the spring latches of the chute align with the latch

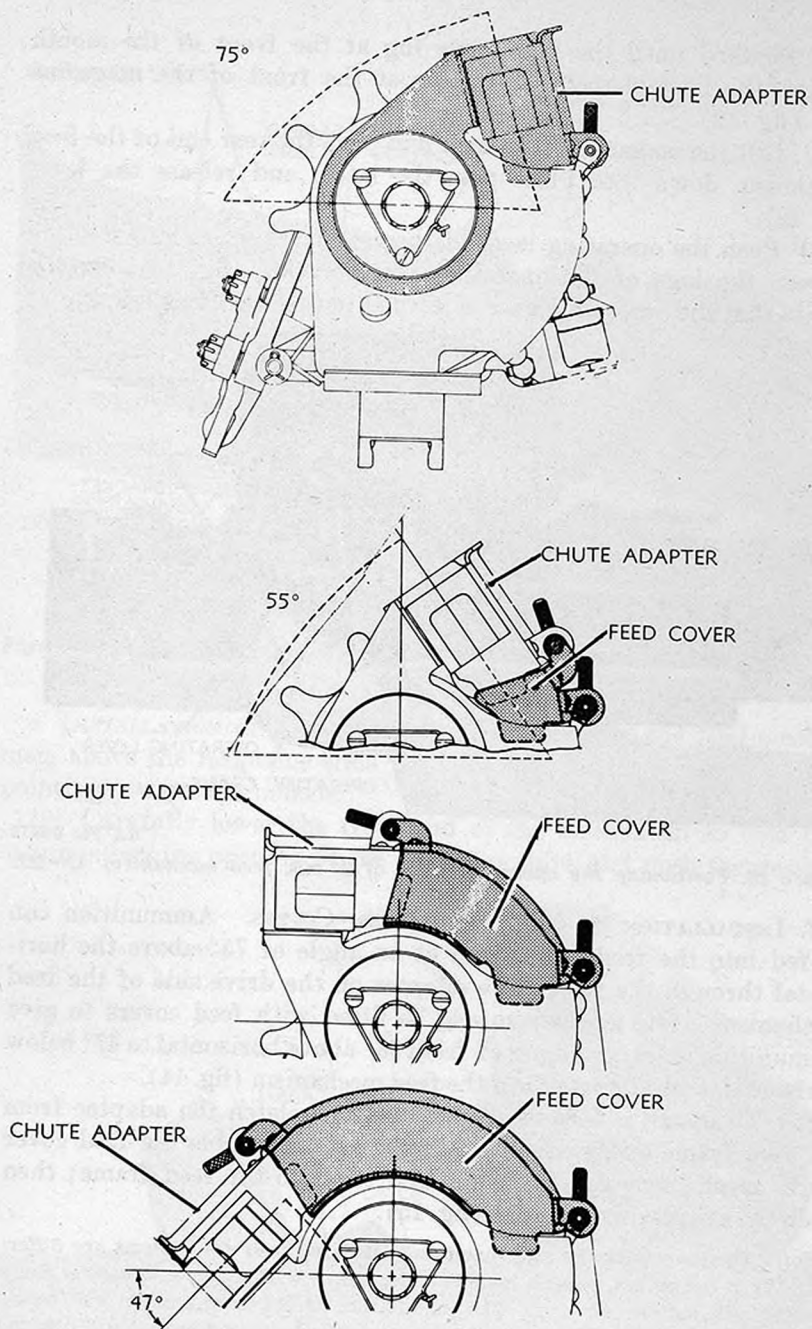

RA PD 93932
Figure 14. Ammunition entrance angles of 20-mm feed mechanism AN-M2.

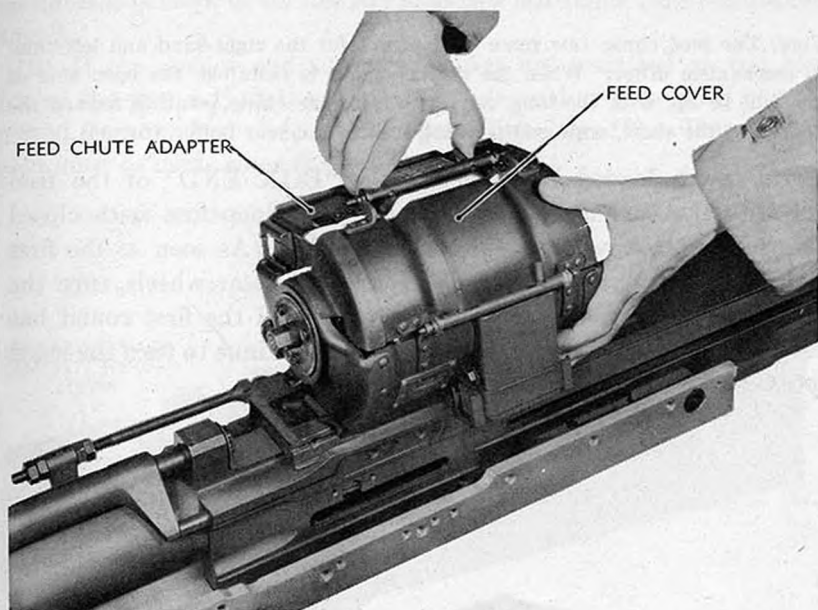

RA PD 93979

Figure 15. Installation of feed cover.

guides of the adapter. Push the chute forward against the adapter until the latches snap into position in the latch guides (fig. 16).

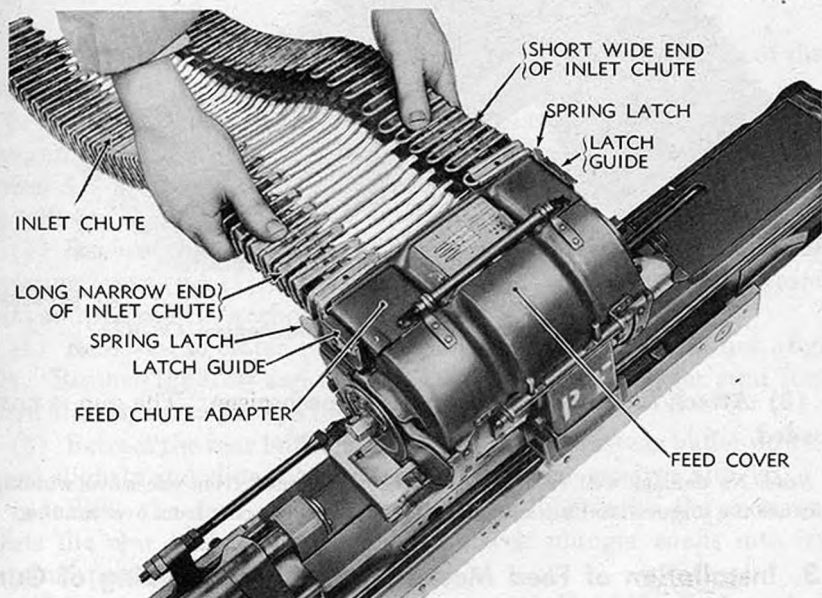

RA PD 93983

Figure 16. Installation of feed chute.

Note: The feed chute (air force equipment) for the right-hand and left-hand feed mechanism differ. When the correct chute is installed, the open side of chute will be up, with the long, narrow end of the chute pointing toward the muzzle, and the short, wide end pointing toward the rear buffer (fig. 16).

(2) Draw a loaded belt through the "BOX END" of the feed chute into the feed mechanism, empty single loop first with closed ends of loops toward open side of feed chute. As soon as the first round of the belt has engaged the teeth of the star wheels, turn the main drive shaft in the direction of feed until the first round has been forced into the mouth (fig. 17). Then continue to turn the shaft approximately three-quarters of a turn.

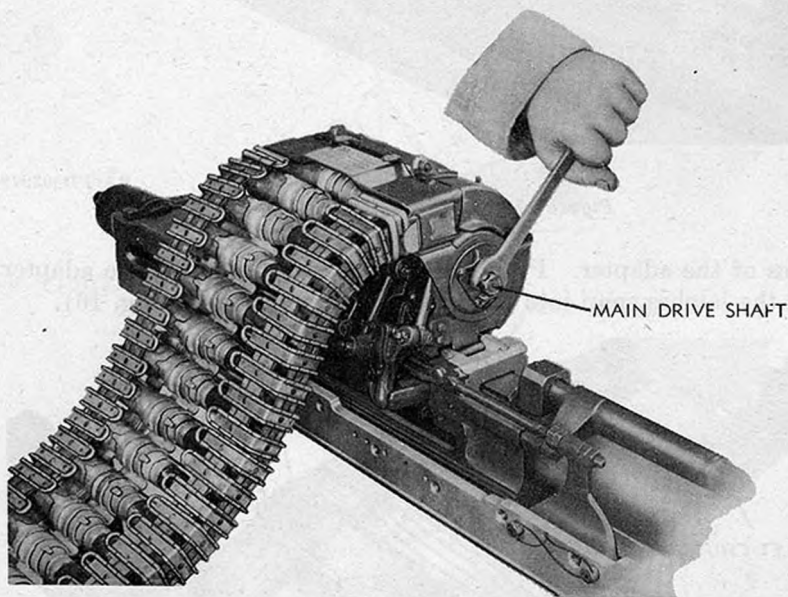

RA PD 93984

Figure 17. Loading the gun (using feed mechanism AN-M2).

(3) Attach the link chute to the feed mechanism. The gun is now loaded.

Note. No damage will result to the feed mechanism from excessive winding because the torque stabilizer action protects the drive spring from overwinding.

13. Installation of Feed Mechanism M3 and Loading of Gun

a. ADJUSTMENT OF FEED SLIDE. (1) The magazine slide anchor and support bracket *must* be installed on right side if a right-hand feed

mechanism is used, or on the left side if a left-hand feed mechanism is used.

(2) If the anchor and support bracket are installed on the feed side of the gun, adjust the magazine slide anchor nuts until the engraved lines on feed slide and receiver aline (fig. 18). This adjustment must be made when the gun is cold.

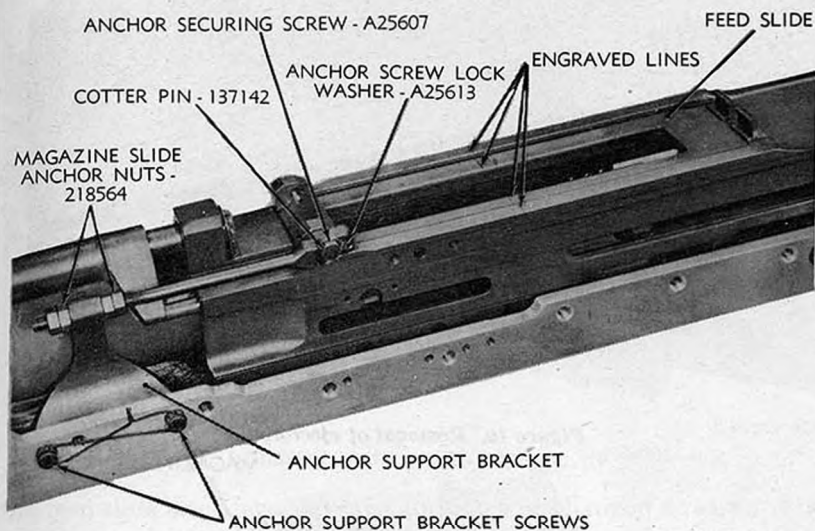

Figure 18. Adjustment of feed slide.

RA PD 108064

(3) If the anchor and support bracket are not on the feed side of the gun, proceed as directed in paragraph 12a (3).

b. REMOVAL OF MAGAZINE SLIDE INSTALLATION OF FEED SLIDE. If the gun is equipped with a magazine slide for installing the feed mechanism AN-M2, and it is desired to use the feed mechanism M3, proceed as follows:

(1) Remove the cotter pin, anchor screw lock washer, and anchor securing screw (fig. 11). Unscrew the two magazine slide anchor front nuts and remove the anchor.

(2) Remove the cotter pin and unscrew the ejector stud nut (fig. 19). Remove the steel and fiber washers. Push the ejector stud forward and withdraw the ejector with the springs.

(3) Retract the rear buffer lock plunger, slide the rear buffer downward slightly and slide the magazine slide off the receiver (fig. 20).

(4) Slide the feed slide (heavy and leading) onto the receiver. Slide the rear buffer upward until the lock plunger snaps into its original position.

c. INSTALLATION OF FEED MECHANISM. (1) Hold the feed mecha-

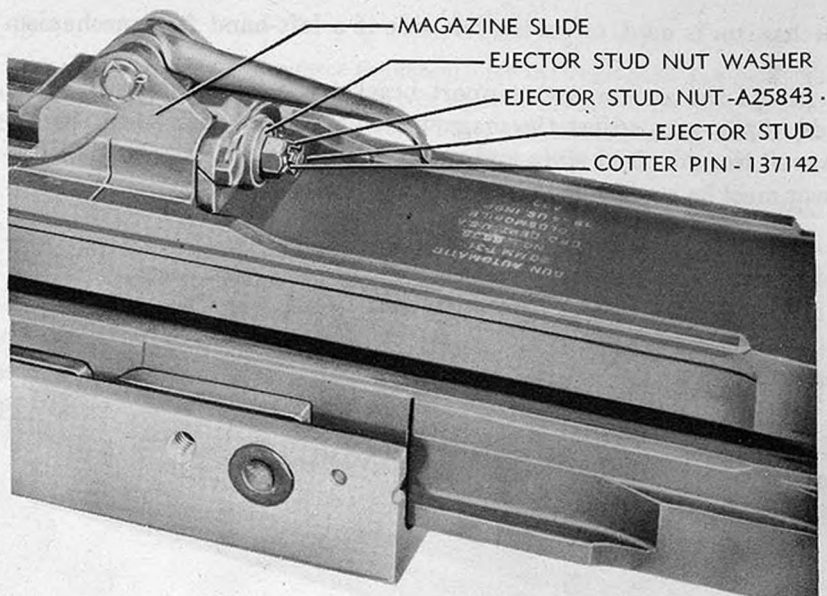

RA PD 108057

Figure 19. Removal of ejector.

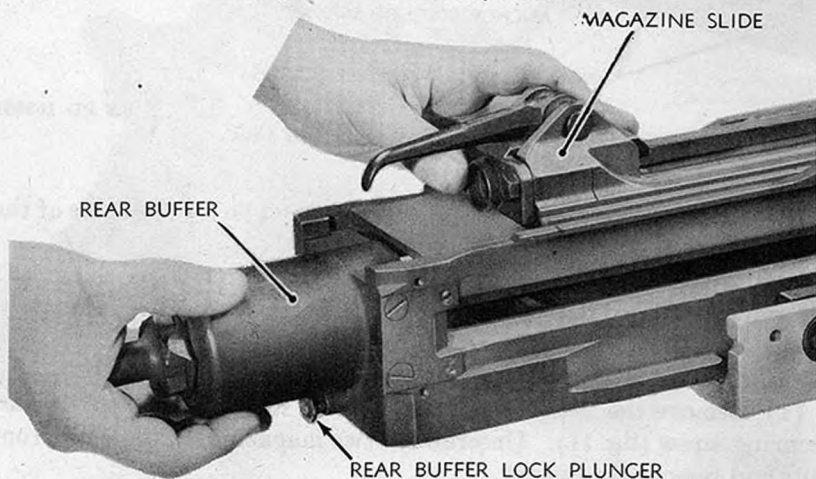

RA PD 93981

Figure 20. Removal of magazine slide.

nism above the feed slide, with the feed wheel shaft pointing toward the muzzle.

(2) Carefully lower the front of the mechanism so that the mouth enters the opening of the feed slide, and push the mechanism forward until the transverse lug at the front of the mouth engages the hook-shaped projections at the front end of the feed slide (fig. 21).

(3) Lower the rear end of the mechanism on the feed slide. Pull



RA PD 93986

Figure 21. Installing 20-mm feed mechanism M3 on the gun.

the feed slide latch lever upward and push mechanism downward into position on the feed slide. Release the latch lever, making certain that the mechanism is securely attached to the slide (fig. 22).

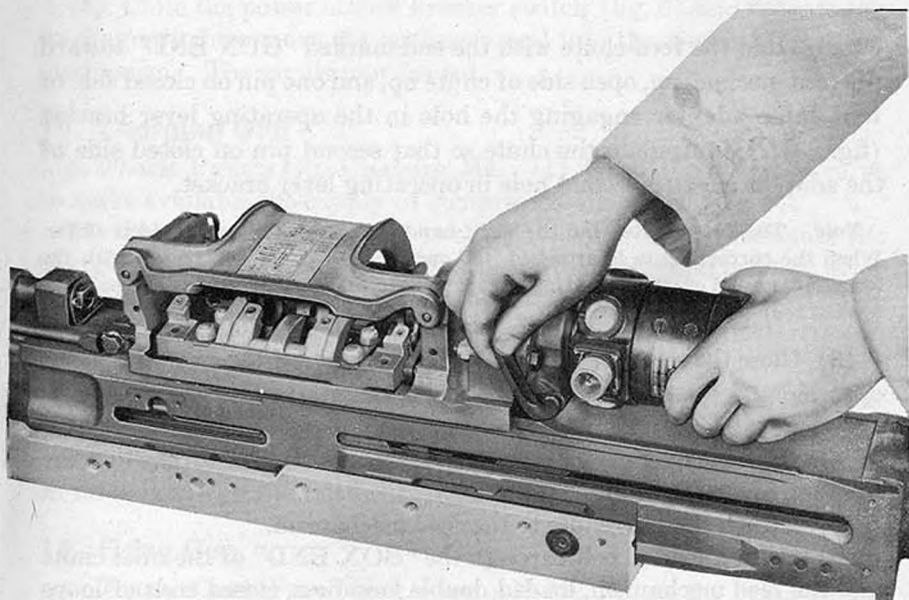

RA PD 93987

Figure 22. Securing 20-mm feed mechanism M3 to the gun.

d. **LOADING GUN.** (1) Pull the cover locking pins outward as far as they will go, raise the stripper cover, and swing it back (fig. 23).

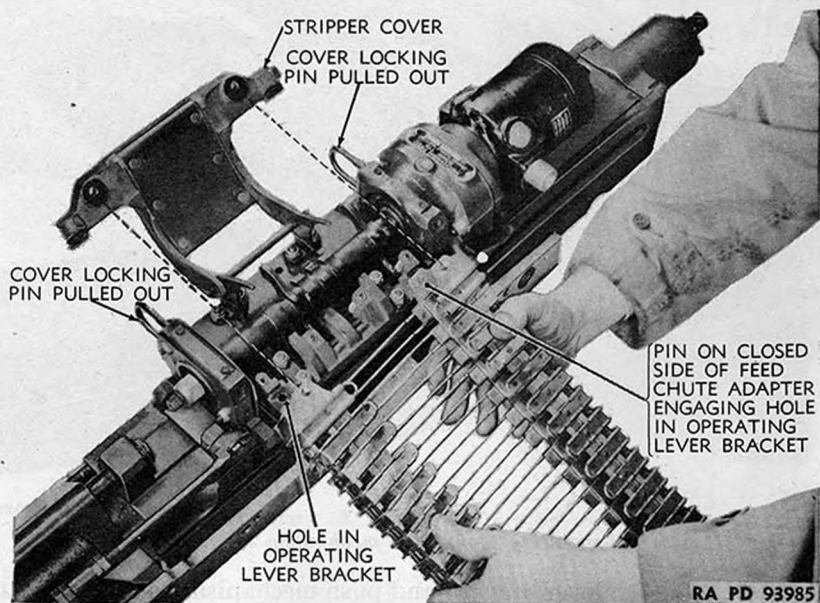

RA PD 93985
RA PD 93985
Figure 23. Installing feed chute on feed mechanism M3.

(2) Hold the feed chute with the end marked "GUN END" toward the feed mechanism, open side of chute up, and one pin on closed side of feed chute adapter engaging the hole in the operating lever bracket (fig. 23). Manipulate the chute so that second pin on closed side of the adapter engages second hole in operating lever bracket.

Note. The feed chutes for the right-hand and left-hand mechanisms differ. When the correct chute is attached, the open side of chute will be up, with the long, narrow end of chute pointing toward muzzle, and the short, wide end pointing toward rear buffer (fig. 23).

(3) Close the stripper cover, making certain that the two pins on the open side of the adapter engage the two holes in the stripper cover (fig. 24).

(4) Push in the cover locking pins, making certain that they lock the stripper cover (fig. 24).

(5) Attach the link chute to the feed mechanism.

(6) Draw a loaded belt through the "BOX END" of the inlet chute into the feed mechanism, loaded double loop first, closed ends of loops toward open side of feed chute, and closed single loop at end (fig. 24).

(7) Position the leading round of ammunition belt in engagement

with the feed wheels in that spacing between the feed wheel sprockets closest to the top of the feed mechanism (fig. 24).

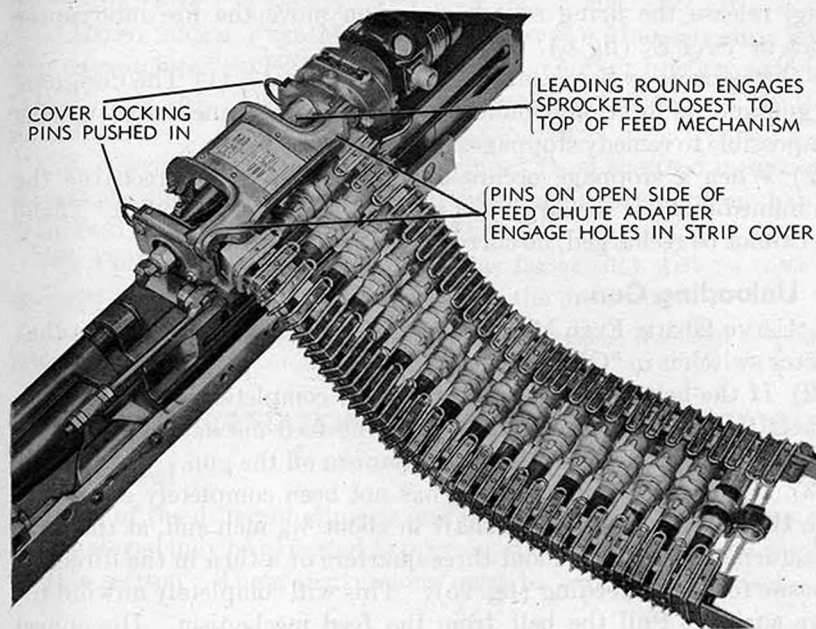

RA PD 108073

Figure 24. Loading the gun (using feed mechanism M3).

(8) Close the power circuit breaker switch (fig. 6) and operate the loading switch to move the leading round into the mouth of the feed mechanism. The gun is now loaded.

14. Charging Gun

a. 20-MM PNEUMATIC CHARGER M4. (1) Open the cylinder valve to make available the supply of compressed air or gas (fig. 5).

(2) If a manually operated two-way valve is used to activate the charger, move the valve lever and return it to its original position after not less than a 1-second delay (fig. 5). If a solenoid controlled valve is used to actuate the charger, squeeze the valve switch momentarily and break the circuit by means of a second switch.

b. 20-MM HYDRAULIC CHARGERS M5 AND M7. Move the lever of the pump valve and release it after not less than a 1-second delay.

c. 20-MM MANUAL CHARGER M6. Pull the charger cable to the rear as far as it will go and release it (fig. 198).

15. Firing Gun

a. USING 20-MM FEED MECHANISM AN-M2. Close the firing switch to fire the gun. To cease firing, release the firing switch.

b. USING 20-MM FEED MECHANISM M3. Move the fire interrupter switch to "FIRE" and close the trigger switch (fig. 6). To cease firing, release the firing switch and then move the fire interrupter switch to "SAFE" (fig. 6).

c. CORRECTION OF STOPPAGES IN COMBAT FIRING. (1) The design of the gun and its location outside the reach of the gunner usually make it impossible to remedy stoppages during combat firing.

(2) When a stoppage occurs during combat firing, recharge the gun immediately, if recharging is possible, and attempt to fire. If the gun cannot be recharged, no corrective action is possible.

16. Unloading Gun

a. USING 20-MM FEED MECHANISM AN-M2. (1) Check to see that selector switch is in "OFF" position.

(2) If the belt of ammunition has been completely expended, disconnect the feed and link chutes from the feed mechanism, raise the magazine slide lever, and lift the mechanism off the gun.

(3) If the belt of ammunition has not been completely expended, push the drive spring release shaft in about $\frac{3}{16}$ inch and, at the same time, turn the shaft for about three-quarters of a turn in the direction opposite to that of feeding (fig. 25). This will completely unwind the drive spring. Pull the belt from the feed mechanism. Disconnect the feed and link chutes from the feed mechanism, raise the magazine slide lever, and lift the mechanism off the gun.

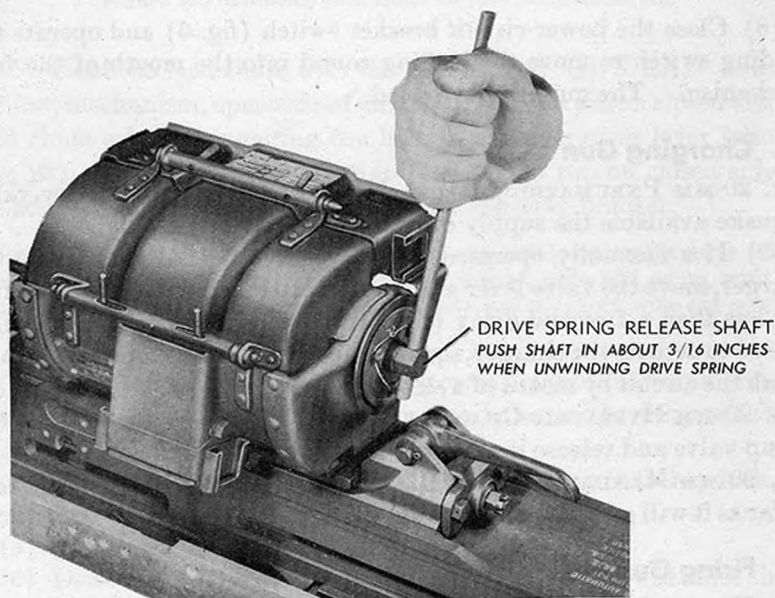

RA PD 94033

Figure 25. Unloading the gun (using 20-mm feed mechanism AN-M2).

Note. If there is a round in the mouth of the magazine, remove it by pushing it forward carefully.

b. USING 20-MM FEED MECHANISM M3. (1) Move the fire inter-rupter switch to "SAFE" and the power and circuit breaker switch to "OFF" (fig. 6). Disconnect the electrical receptacles at the feed mechanism.

(2) Disconnect the feed and link chutes from the feed mechanism. Rotate the slide latch lever upward, disengage rear end of mechanism from feed slide, and lift mechanism off the gun.

(3) Pull out the cover locking pins as far as they will go, raise the stripper cover, and remove the belt from the mechanism.

Note. If there is a round in the mouth of the magazine, remove it by pushing it forward carefully.

Section VII. OPERATION UNDER UNUSUAL CONDITIONS

17. General

Because of the different climatic and temperature conditions in which this matériel may be expected to operate, special instructions are given in this section. These instructions must be carefully observed.

18. Extreme High Temperatures

a. LUBRICATION. Lubricate the gun as directed in section XII. In extremely high temperatures, lubricate more frequently.

b. INSPECTION AND CARE. (1) Matériel should be inspected frequently when being operated in hot, moist areas. Items which may deteriorate from mildew, etc., or be attacked by insects or vermin should be aired or dried frequently.

(2) Ammunition should be kept out of the direct rays of the sun. Moisture-resistant seals should not be broken until ammunition is to be used.

19. Subzero Temperatures

a. In temperatures below freezing, it is essential that all moving parts be kept absolutely free of moisture. It has been found that excess oil on the working parts will solidify to such an extent as to cause sluggish operation or even complete failure. Extreme cleanliness and the sparing application of oil are requirements.

b. When gun is brought into a heated shop, condensation will occur on all metal surfaces. After the gun reaches shop temperature, all parts must be wiped dry and recoated with oil to prevent rusting.

c. In applying oil to the bore after cleaning, care must be taken to work the oil in well so that it will reach all surfaces of the lands and grooves.

d. Clean the breechblock parts with rifle-bore cleaner. Apply oil

by wiping the rubbing surfaces of the breechblock parts with a clean cloth which has been wet with the oil and wrung out.

e. When matériel is protected with a canvas or other type of cover, moisture will form on the metal surfaces. To prevent rusting, the cover must be removed at least weekly, and all surfaces thoroughly dried. Reoil where necessary.

20. Excessively Moist or Salty Atmosphere

a. When the matériel is active, clean and relubricate exposed metal surfaces such as the gun, breechblock, cradle surfaces, etc., more frequently, as water will emulsify with oil and destroy its rust-preventive qualities. Inspect parts frequently for corrosion.

b. Preservative lubricating oil (medium) will be used in lieu of lubricating oil (special).

c. The bore of the tube and the breechblock should be kept heavily oiled and should be inspected frequently for rust. Wipe the bore clean before flight when firing is contemplated.

21. Excessively Sandy or Dusty Conditions

a. When the gun is active in dusty or sandy areas, inspect and wipe the gun clean daily, or more often if necessary. Groups should be removed to facilitate thorough cleaning.

b. Lubrication should be kept to a minimum because oil collects dust which will act as an abrasive and may foul the bore and chamber. Preservative lubricating oil (special) should be applied lightly to working parts.

c. Keep the breech and muzzle covered when practicable.

Section VIII. DEMOLITION TO PREVENT ENEMY USE

22. General

a. The destruction of the matériel when subject to capture or abandonment in the combat zone will be undertaken by the using arm only as a command function, on authority delegated by the division or higher command, when such action is deemed necessary as a final resort to keep the matériel from reaching enemy hands.

b. Adequate destruction of the matériel means damaging it in such a way that the enemy cannot restore it to usable condition in the combat zone either by repair or cannibalization. Adequate destruction requires that:

(1) Enough parts essential to the operation of the matériel must be damaged.

(2) Parts must be damaged beyond repair in the combat zone.

(3) The same parts must be destroyed on all matériel, so that the

enemy cannot make up one operating unit by assembling parts from several partly destroyed units.

c. Generally, the destruction of the airplane by incendiary means is sufficient to make the armament useless. However, in cases where it is impractical to set fire to the airplane, any of the methods given below should be employed. The methods are listed in order of effectiveness, but the selection of any particular method is a command function.

23. Destruction by TNT

a. Remove a high-explosive shell from a complete round and seat the shell in the chamber.

b. Plug the bore, for approximately two-thirds of its length, using a ramrod wrapped with cloth or waste to make it fit tightly in the bore; mud, stones, clay, etc. may be used to plug the bore in lieu of the ramrod.

c. Cut down a ½-pound TNT block to fit snugly in the receiver behind the high-explosive shell. Insert a tetryl nonelectric cap, with approximately 3 to 4 feet of safety fuze, into the TNT block. Close the breech as far as possible without damaging the safety fuze.

d. Ignite the safety fuze and take cover at least 100 yards from the gun. Elapsed time: 2 to 3 minutes if ramrod is used to plug the bore and cut-down TNT block is carried with gun; longer if other bore obstructions are used.

24. Destruction by Explosion of Projectile in Plugged Bore

a. See paragraph 23*b*.

b. Insert one complete high-explosive round into gun.

c. Take cover and fire the gun, using a lanyard 100 feet long. Elapsed time: 1 to 2 minutes, using ramrod to plug the bore; longer if bore is plugged with mud, etc.

25. Destruction by Explosion of One Projectile Against Another in Bore

a. Insert the projectile end of a complete high-explosive round into the muzzle as far as it will go. Do not hit the primer.

b. Load the gun with a complete high-explosive round.

c. Take cover and fire the gun, using a lanyard of 100 feet.

Note. For demolition of ammunition, see TM 9-1901.

PART THREE

MAINTENANCE INSTRUCTIONS

Section IX. GENERAL

26. Scope

a. Part Three contains information for the guidance of the using arms and ordnance maintenance personnel charged with the maintenance of the matériel.

b. The information for the using troops consists of descriptions of the major systems and units, their functions, scheduled lubrication and preventive maintenance services, and organizational (first and second echelons) maintenance.

c. The information for the ordnance maintenance personnel consists of detailed instructions required for the ordnance maintenance and rebuilding (third, fourth, and fifth echelons) of the matériel.

27. Cleaning, Preserving, and Lubricating Materials

The following cleaners and preservatives are required for use with this matériel:

CLEANER, rifle-bore.

CLOTH, bore-cleaning.

CLOTH, crocus, sheet.

CLOTH, wiping, cotton.

OIL, lubricating, preservative, medium.

OIL, lubricating, preservative, special.

SOLVENT, dry-cleaning.

Section X. SPARE PARTS, TOOLS, AND EQUIPMENT

28. Spare Parts, Tools, and Equipment

a. SPARE PARTS. Spare parts are available for maintenance and repair to all echelons. A set of spare parts is supplied to the using arm for field replacement of those parts most likely to become worn, broken, or otherwise unserviceable.

b. TOOLS AND EQUIPMENT. Tools and equipment are available to all echelons for disassembly, assembly, cleaning and preserving the gun, automatic, 20-mm, M3. A set of tools and equipment is supplied to the using arm for their limited maintenance of the matériel. Tools

and equipment should not be used for purposes other than prescribed and, when not in use, should be properly stored in the chest and/or roll provided for them.

c. LIST OF SPARE PARTS, TOOLS, AND EQUIPMENT. Spare parts, tools, and equipment supplied for gun, automatic, 20-mm, M3, are listed in WD Supply Catalog ORD 7 SNL A-47 for the using arm. Spare parts for ordnance maintenance are listed in WD Supply Catalog ORD 8 SNL A-47. Tools and equipment supplied for ordnance maintenance are listed in WD Supply Catalog ORD 6 SNL A-35, Section 4. These publications are the authorities for requisitioning replacements.

29. Specially Designed Tools and Equipment

Certain tools and equipment (both authorized and improvised) are specially designed for maintenance, repair and general use with the gun, automatic, 20-mm, M3. These tools and equipment are listed below for information only. This list is not to be used for requisitioning replacements.

Item	Identifying No.	References		Using arm	Ord. maint.	Use
		Fig.	Text			
<i>Authorized Tools</i>						
BRUSH, bore, M25	B7225087			x	x	Clean and oil gun tube.
CHARGER, hydraulic, 20-mm, M7.	D7228987	26	XXV	x		Charge gun.
CHARGER, manual, 20-mm, M6.	C7227817	26	XXVII	x		Charge gun.
CHARGER, pneumatic, 20-mm, M4.	D7228217	26	XXIV	x		Charge gun.
CLAMP, tube assembly	41-C-2005	31	63e(3)		x	For removing tube, in conjunction with Receiver Vise 40-V-405.
COVER, muzzle, 20-mm, M336.	B7230224			x		Protect gun tube from foreign matter.
HEATER, gun, M1	D7229391	27	XXX	x		Heat gun at low temperatures.
HIDER, flash, 20-mm, M4 and nut.	C7229909	61	63c	x		Reduce and hide muzzle flash.
MACHINE, linking, 20-mm, ammunition, M4.	D69370	37	31	x		Rapid loading of ammunition into metallic links.
MACHINE, linking, 20-mm, ammunition, M13.	D7226304	39	32	x		Rapid loading of ammunition into metallic links.
MANUAL, technical, 9-229.	TM 9-229			x	x	Instructional purposes.
MECHANISM, feed, 20-mm, AN-M2, left-hand.	D7225420	89	XXII	x		Feed linked ammunition into weapon.
MECHANISM, feed, 20-mm, AN-M2, right-hand.	D7225419	87	XXII	x		Feed linked ammunition into weapon.
MECHANISM, feed, 20-mm, M3, left-hand with equipment.	D7225751	121	XXIII	x		Feed linked ammunition into weapon.
PLIERS, snap ring, w/ setscrew.	41-P-1992-28	28	85k		x	Remove pinion retaining ring from planet gear unit.

Item	Identifying No.	References		Using arm	Ord. maint.	Use
		Fig.	Text			
<i>Authorized Tools</i>						
MECHANISM, feed, 20-mm, M3, left-hand with equipment—Continued						
PLIERS, snap ring, w/setscrew.	41-P-1992-35...	28	85j	-----	x	Remove retaining ring from bearing at rear of feed wheel shaft.
SCALE, weighing, spring balance, stght., sgle. hook, cap. 30 lb.	18-S-1419.....	28	86g	x	x	Used with Wrench, 41-W-528-640, to test torque of feed clutch plates.
SCREW, clutch puller, 8-36NF-2 thread, length over-all 2 in.	41-S-1026-700..	28	85	-----	x	To remove clutch.
WRENCH, bearing lock nut.	41-W-3247-115.	28	86g	x	x	For clutch adjusting nut on feed wheel shaft.
WRENCH, torque, flat bar type box, hex. size of opng. 3/8 in., length 10 3/4 in.	41-W-528-640..	28	86g	x	x	Used with Scale, 18-S-1419, to test torque of feed clutch plates.
MECHANISM, feed, 20-mm, M3, D7225753 right-hand with equipment.	D7225753.....	119	XXIII	x	-----	Feed linked ammunition into weapon.
PLIERS, snap ring, w/setscrew.	41-P-1992-28..	28	85k	-----	x	Remove pinion retaining ring from planet gear unit.
PLIERS, snap ring, w/setscrew.	41-P-1992-35..	28	85j	-----	x	Remove retaining ring from bearing at rear of feed wheel shaft.
SCALE, weighing, spring balance, stght., sgle. hook, cap. 30 lb.	18-S-1419.....	28	86g	x	x	Used with Wrench, 41-W-528-640, to test torque of feed clutch plates.
SCREW, clutch puller, 8-36NF-2 thread, length over-all 2 in.	41-S-1026-700..	28	85f	-----	x	To remove clutch.
WRENCH, bearing lock nut.	41-W-3247-115.	28	86g	x	x	For clutch adjusting nut on feed wheel shaft.
WRENCH, torque, flat bar type box, hex. size of opng. 3/8 in., length 10 3/4 in.	41-W-528-640..	28	86g	x	x	Used with Scale, 18-S-1419, to test torque of feed clutch plates.
OILER, rectangular, stght. spout, cap. 12 oz., w/cap and chain.	13-O-800.....	29	-----	x	-----	Container and dispenser of lubricating fluid.
ROLL, tool, canvas, empty, model M6, size 18 by 18 in. (w/o contents).	41-R-2712.....	-----	-----	x	x	Store gun tools.
STAFF, cleaning, 20-mm, M13.	C70631.....	29	-----	x	x	Used w/bore brush to clean and oil gun.
TOOL, assembling, driving spring.	41-T-3017-500.	30	65c	x	x	To aid in installation of driving spring guide and plunger.
TOOL, assembling, sear block.	41-T-3019.....	30	69d	x	x	To compress the plunger springs in the sear block after removal from gun. Used in conjunction with Tool, 41-T-3336.
TOOL, retaining, sear block spring, length 4 3/4 in.	41-T-3336.....	30	68c	x	x	Insert into hole in sear block to engage recesses in sear plungers, thus holding the springs compressed for removal from gun.

Item	Identifying No.	References		Using arm	Ord. maint.	Use
		Fig.	Text			
<i>Authorized Tools</i>						
TOOL, unlocking, breechblock.	41-T-3380-20	30	68a	x	x	To retract breechblock slides far enough to raise lock from locking key when removing breechblock.
TOOL, tube locking pin, removing.	41-T-3378-87	31	63e(3)	-----	x	Remove tube locking pin from tube and receiver.
TRIGGER, electric, 20-mm, AN-M1A1.	A7230196	27	XXVIII	x	-----	Fire gun.
TRIGGER, electric, 20-mm, AN-M4.	C7229054	27	XXIX	x	-----	Fire gun.
WISE, receiver, clamp type..	41-V-405	31	63e	-----	x	In conjunction with Tube Clamp 41-C-2005 for holding receiver while removing tube.
WRENCH, buffer, rear	41-W-1990-400	30	-----	x	x	To remove and install driving spring guide.
WRENCH, engr., angle 15 deg., sgle. open end, alloy S., size of opng. 1 1/16 in.	41-W-1209-40	30	-----	x	x	For gas cylinder vent plug and guide nut.
WRENCH, hydraulic charger (pin spanner, diam. of circle 1.34 in., length 4.86 in.).	41-W-3255-123	30	-----	x	x	To tighten cylinder end lock ring on M4 and M7 charges.
<i>Improvised tools</i>						
BLOCKS, gun mounting	-----	32	-----	-----	x	To mount the gun in a horizontal position to permit overhaul.
FIXTURE, driving mechanism holding.	-----	33	80a	-----	x	To hold driving mechanism assembly of Feed Mechanism AN-M2 while installing or removing clutch pocket pins.
DRIVER, planet pinion bearing.	-----	34	89d	-----	x	To install needle bearings in both ends of planet pinions, Feed Mechanism M3.
DRIVER, planet cage bearing.	-----	35	89d	-----	x	To install needle bearings in both ends of planet cage, Feed Mechanism M3.
TOOL, plunger seal installing.	-----	36	86d	-----	x	To install felt plunger seals in feed frame of Feed Mechanism M3.

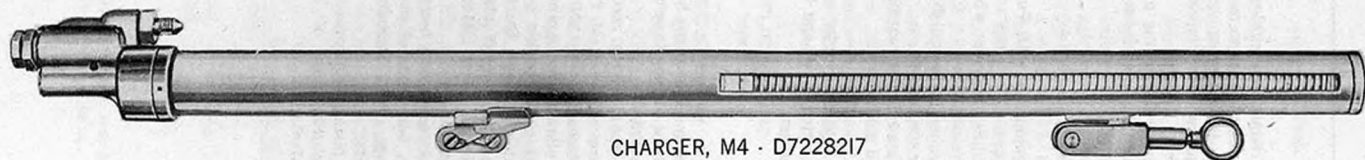

CHARGER, M4 - D7228217



CHARGER, M6 - C7227817

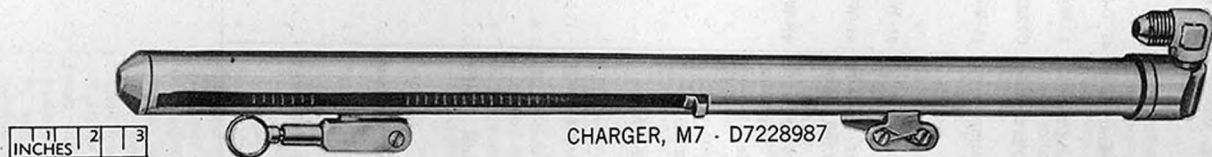

CHARGER, M7 - D7228987

Figure 26. Chargers.

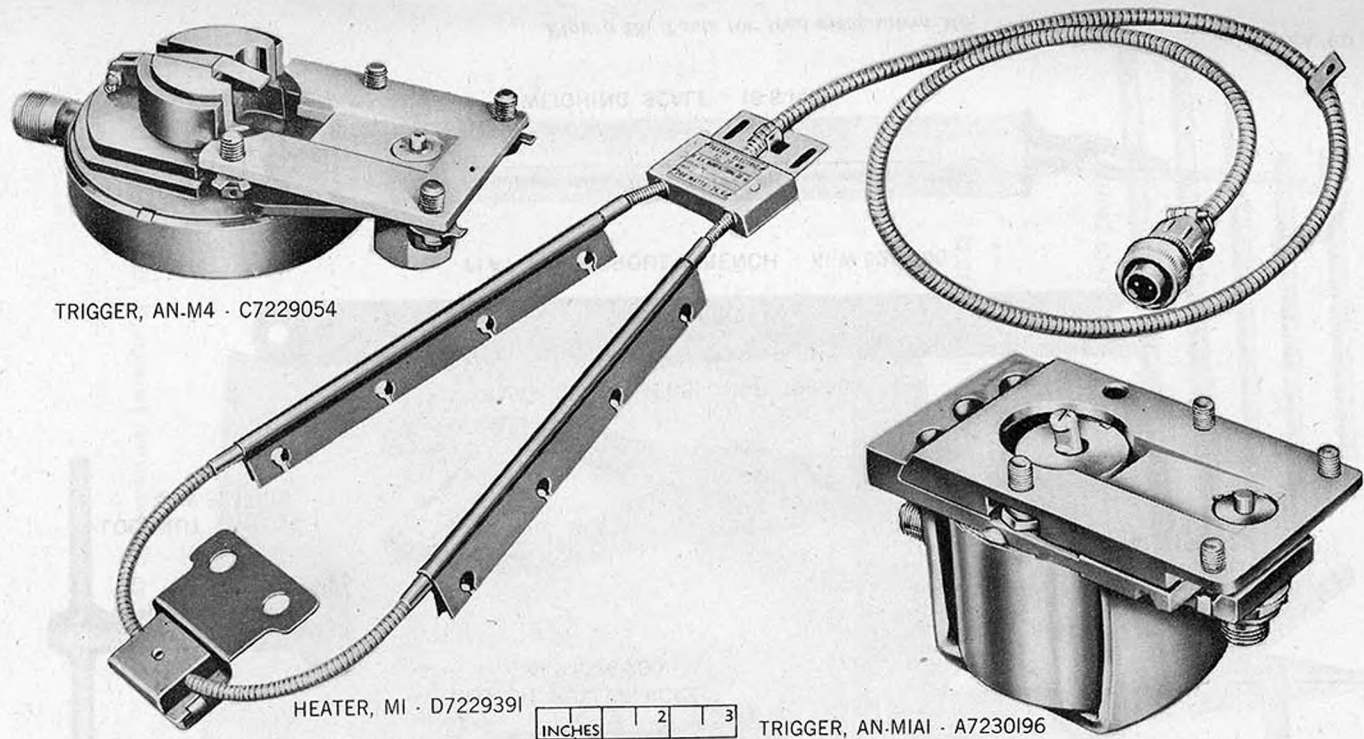

TRIGGER, AN-M4 · C7229054

HEATER, MI · D7229391

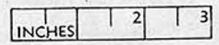

TRIGGER, AN-MIAI · A7230196

Figure 27. Heater and electric triggers.

RA PD 110739

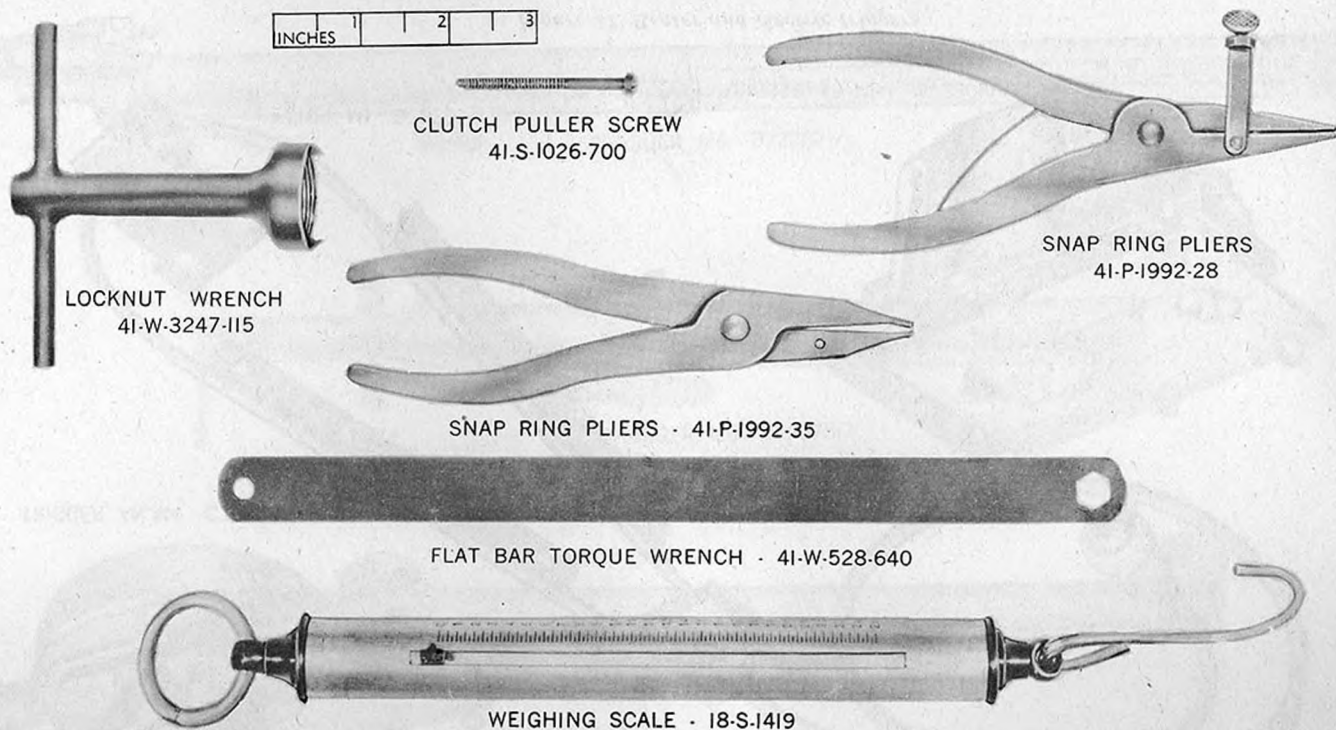
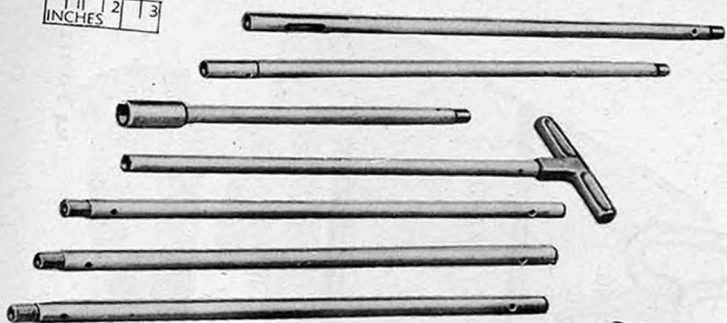

Figure 28. Tools for feed mechanism M3.

1 1 2 3
INCHES



CLEANING STAFF, M13 - C70631

RECTANGULAR OILER - 13-O-800



INCHES 1

Figure 29. Equipment for automatic gun M3.

RA PD 111184



WRENCH, ENGINEERS ANGLE 15°
41-W-1209-40



WRENCH, HYDRAULIC,
CHARGER - 41-W-3255-123

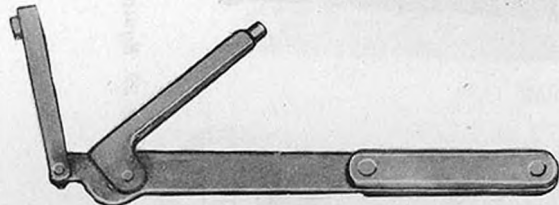
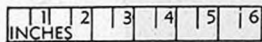

TOOL, UNLOCKING BREECHBLOCK - 41-T-3380-20

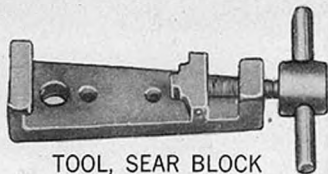

TOOL, SEAR BLOCK
ASSEMBLING - 41-T-3019

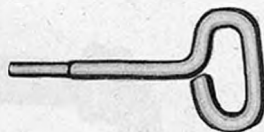

TOOL, RETAINING -
41-T-3336

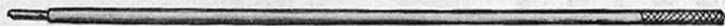

TOOL ASSEMBLING DRIVING SPRING - 41-T-3017-500



WRENCH, REAR BUFFER - 41-W-1990-400



Figure 30. Tools for automatic gun M3.

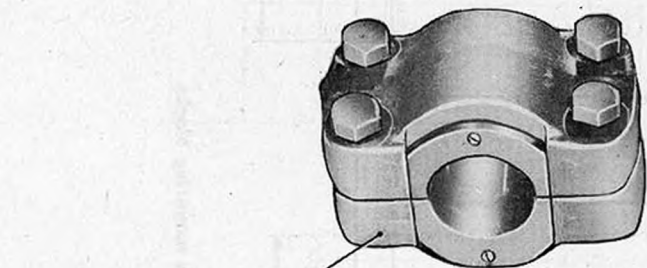

CLAMP, TUBE - 41-C-2005

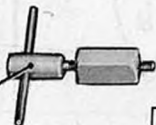

TOOL, TUBE LOCKING PIN
REMOVING - 41-T-3378-87

INCHES³

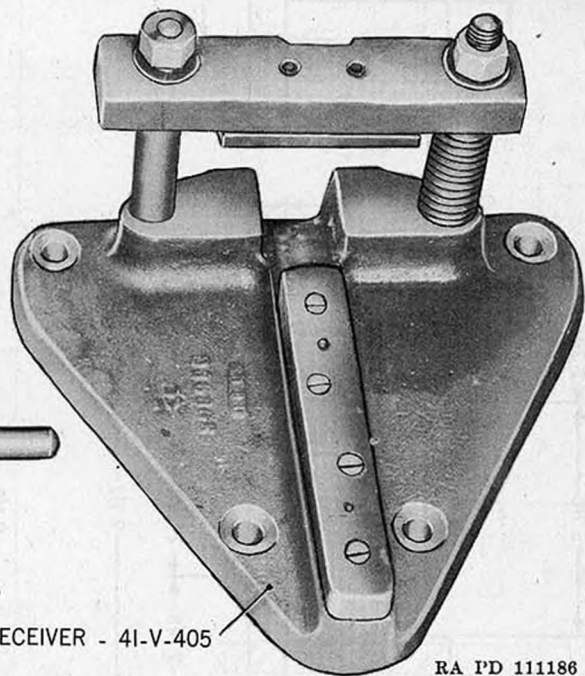

WISE, RECEIVER - 41-V-405

RA PD 111186

Figure 31. Tools for automatic gun M3.

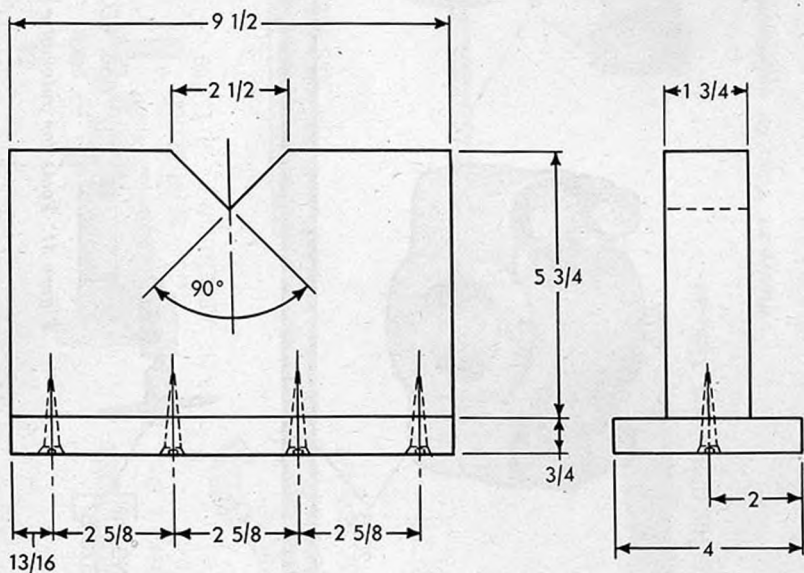
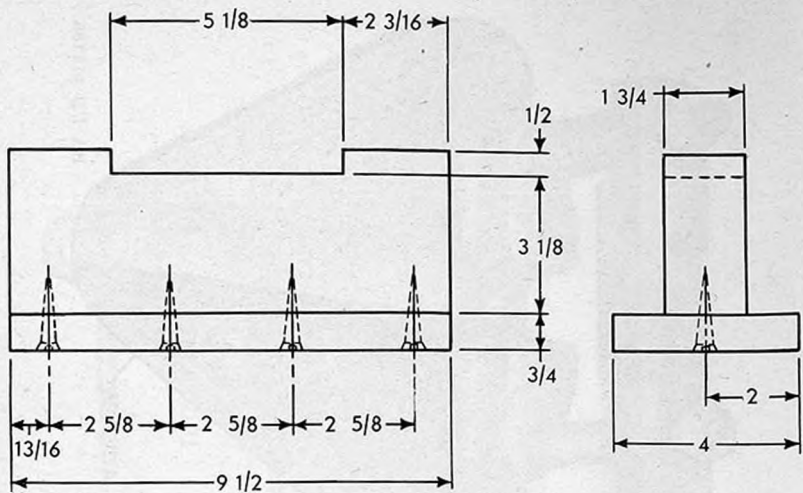

Figure 32. Gun mounting blocks.

RA PD 91028

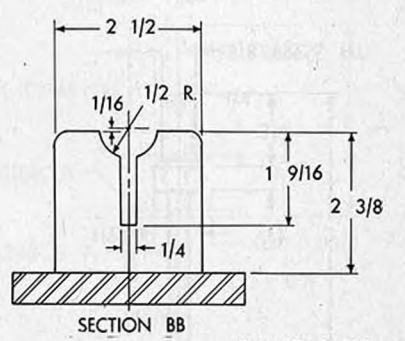
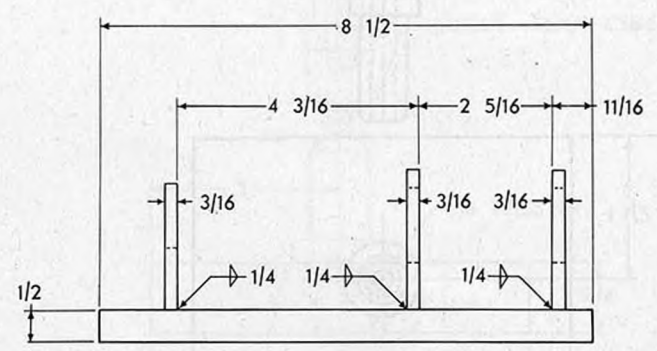
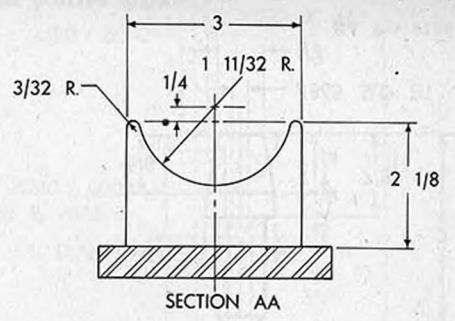
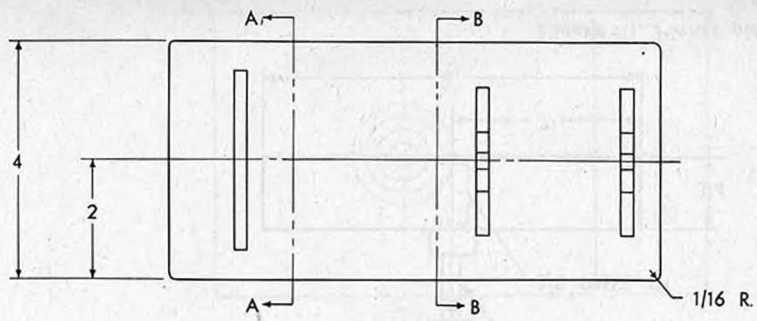
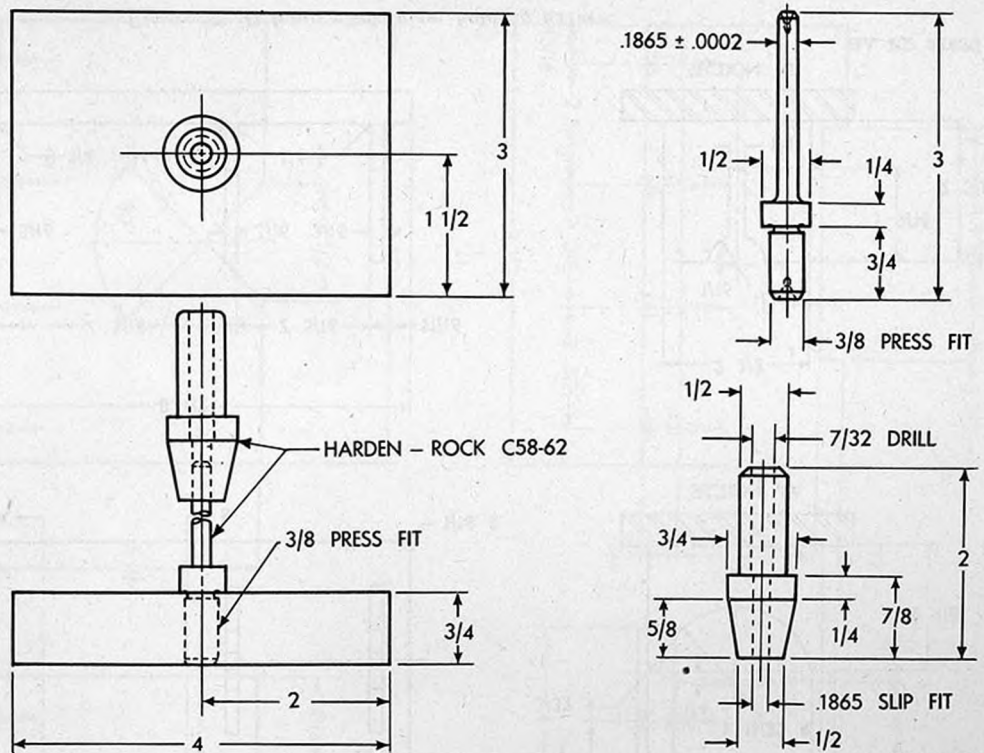

Figure 33. Driving mechanism holding fixture.

RA PD 91035



RA PD 91030

Figure 34. Planet pinion bearing driver.

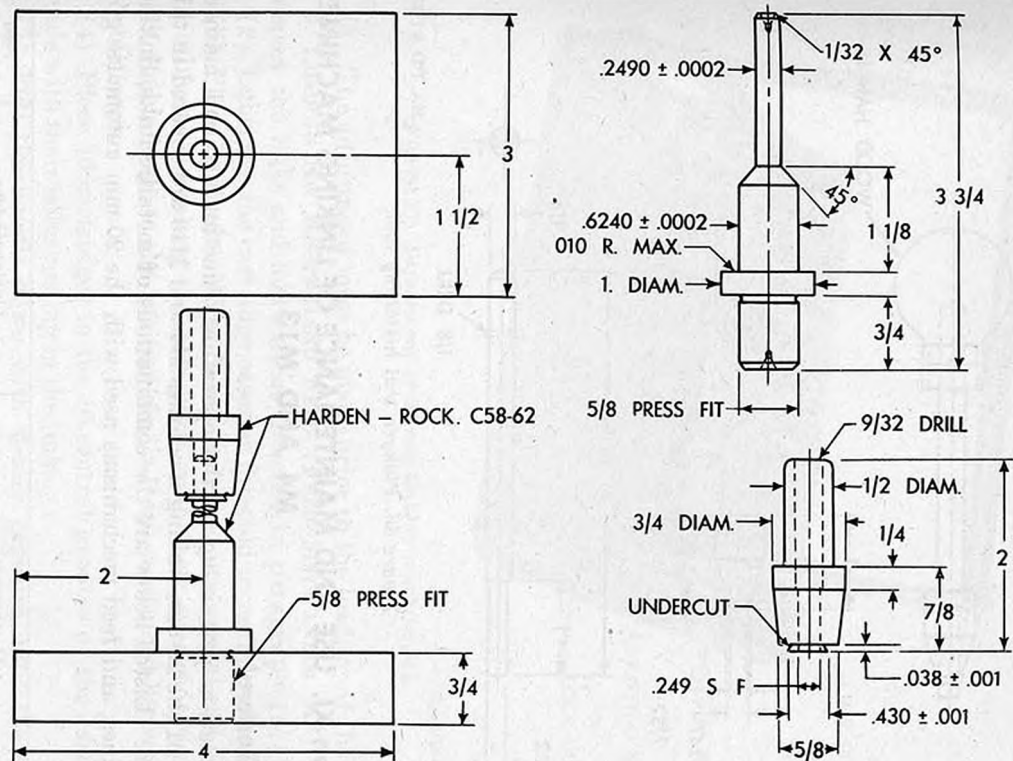

RA PD 91031

Figure 35. Planet cage bearing driver.

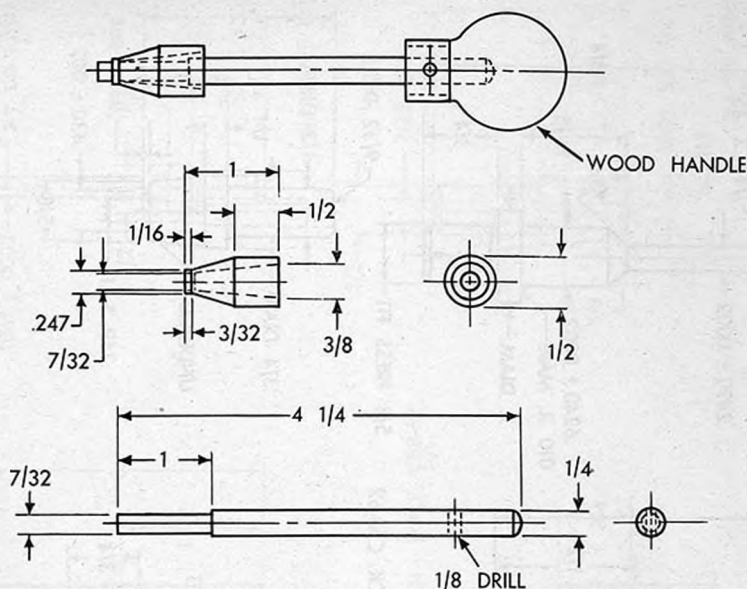

Figure 36. Plunger seal installing tool.

RA PD 91033

Section XI. USE AND MAINTENANCE OF LINKING MACHINES M4 AND M13

30. General

Information pertaining to the operation, functioning, and maintenance of the 20-mm linking machines M4 and M13 are covered in this section. Listed below are the combinations of metallic links, linking machines, and feed mechanisms used with the 20-mm automatic gun M3.

Metallie link	Linking machine	Feed mechanism
M3 and M3A1	M4	M3.
M7 and M8	M13	M3.
M7 and M8	M13	AN-M2.

31. 20-mm Linking Machine M4

a. ADJUSTMENT OF 20-MM LINKING MACHINE M4. (1) The machine is provided with lock nuts and two adjusting bolts on the pusher bar to regulate the length of the stroke. These should be set so that when the pusher bar is in its forward position, the distance between the face of the bar and the link stop is $3\frac{3}{4}$ inches $\pm \frac{1}{16}$ (fig. 37).

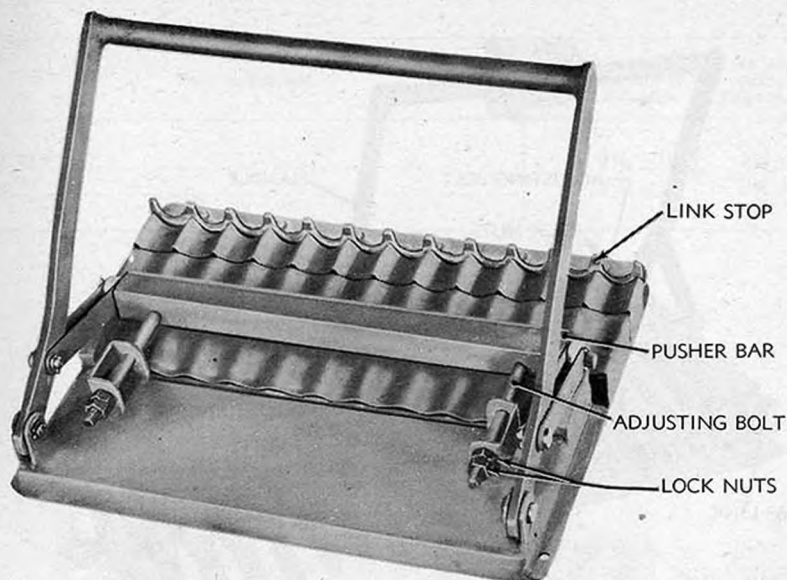

RA PD 104482

Figure 37. Adjustment of 20-mm linking machine M4.

(2) The adjustment must be made prior to the loading of the belts.

b. LOADING FOR RIGHT-HAND FEED (FEED MECHANISM M3). (1) Inspect the links and lubricate as directed in paragraph 11a(1).

(2) Lubricate the cartridge cases as directed in paragraph 11a(1).

(3) Place 10 regular M3 or M3A1 links and one special end link in a continuous row along the link guide, with their open sides up, and with double loops to the left and single loops positioned between the double loops.

(4) Place 10 cartridges in the 10 central grooves of the cartridge guide with their noses resting in the links.

(5) Pull the handle down with steady pressure until the stroke is stopped by the lock nuts on the adjustment bolts.

(6) Push back the handle. Lift out the 10 cartridges, which are now linked together, and place the right end cartridge in the left end groove. Place additional links and cartridges in the guides and repeat the operations until the belt is of the desired length (fig. 38). The special end link with the closed loop must be at the right end of the complete belt.

(7) Test flexibility of belt and for oversize links as directed in paragraph 11a(2)(d), (e), and (f).

c. LOADING FOR LEFT-HAND FEED (FEED MECHANISM M3). (1) Inspect and lubricate the links as directed in paragraph 11a(1).

(2) Lubricate the cartridges as directed in paragraph 11a(1).

(3) Place 10 regular M3 or M3A1 links and one special end link

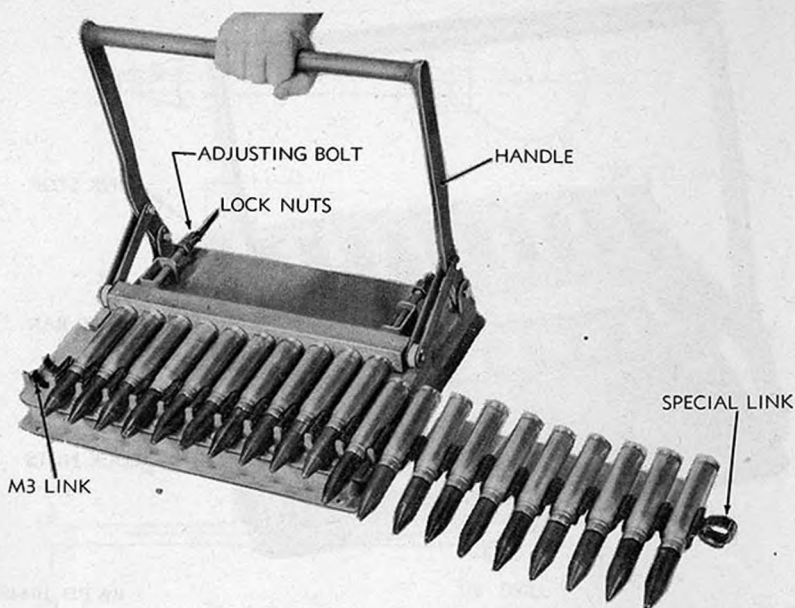

RA PD 104483

Figure 38. Belting ammunition for feed mechanism M3 using 20-mm linking machine M4.

in a continuous row in the 10 central grooves of the link guide, with their open sides up, and with double loops to the right and single loops positioned between the double loops. The special end link should be at the right end.

(4) Place 10 cartridges in the 10 central grooves of the cartridge guide with their noses resting in the links.

(5) Pull the handle down with steady pressure until the stroke is stopped by the lock nuts on the adjustment bolts.

(6) Push back the handle. Lift out the 10 cartridges which are now linked together and place the left end cartridge in the right end groove. Place additional links and cartridges in the guides and repeat the operations until the belt is of the desired length. The special end link must be at the left end of the complete belt.

(7) Test flexibility of belt and for oversize links as directed in paragraph 11a(2) (d), (e), and (f).

32. 20-mm. Linking Machine M13

a. ADJUSTMENT OF 20-MM LINKING MACHINE M13. (1) The machine is provided with lock nuts and two adjustment bolts on the pusher bar to regulate the length of stroke. Adjustment is as follows (fig. 39):

Feed mechanism	Distance from pusher bar face to nearest link edge	Link stop setting (approx.)
AN-M2.....	$2\frac{9}{32} \pm \frac{1}{16}$	$3\frac{3}{4} \pm \frac{1}{16}$
M3.....	$2\frac{5}{16} \pm \frac{1}{16}$	$3\frac{3}{4} \pm \frac{1}{16}$

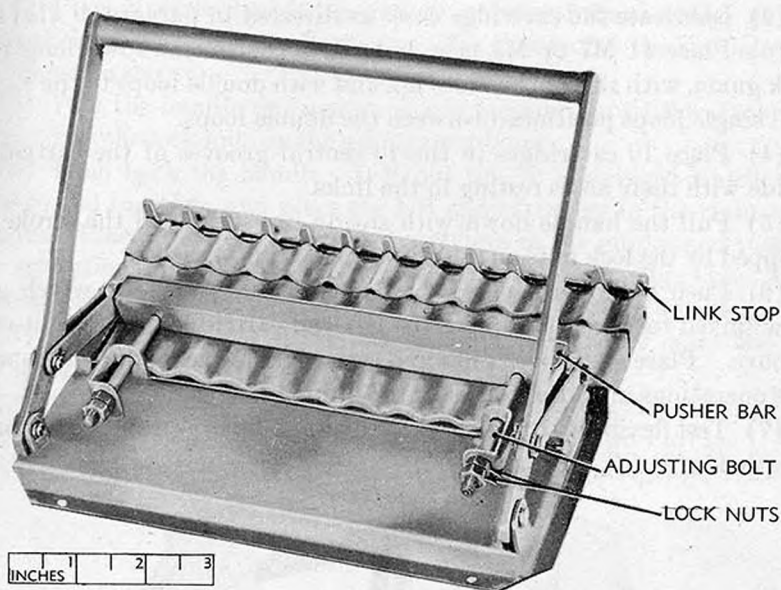

RA PD 104484

Figure 39. Adjustment of 20-mm linking machine M13.

(2) This adjustment must be made prior to the loading of the belts.

b. LOADING FOR RIGHT-HAND FEED (FEED MECHANISM M3). (1) Inspect and lubricate the links as directed in paragraph 11*a*(1).

(2) Lubricate the cartridges as directed in paragraph 11*a*(1).

(3) Place 10 regular M7 or M8 type links and one special end link in a continuous row along the link guide, with their open sides up, and with double loops to the left and single loops positioned between the double loops.

(4) Place 10 cartridges in the 10 central grooves of the cartridge guide with their noses resting in the links. The groove for the special end link must be empty.

(5) Pull the handle down with steady pressure until the stroke is stopped by the lock nuts on the adjustment bolts.

(6) Push back the handle. Lift out the 10 cartridges which are now linked together, and place the right-end cartridge in the left-end groove. Place additional links and cartridges in the guides and re-

peat the operations until the belt is of the desired length. The special end link with the closed loop must be at the right end of the complete belt.

(7) Test the belt for flexibility and for oversize links as described in paragraph 11a(2)(d), (e), and (f).

c. LOADING FOR RIGHT-HAND FEED (FEED MECHANISM AN-M2).

(1) Inspect the links and lubricate as directed in paragraph 11a(1).

(2) Lubricate the cartridge cases as directed in paragraph 11a(1).

(3) Place 11 M7 or M8 type links in a continuous row along the link guide, with their open sides up, and with double loops to the right and single loops positioned between the double loops.

(4) Place 10 cartridges in the 10 central grooves of the cartridge guide with their noses resting in the links.

(5) Pull the handle down with steady pressure until the stroke is stopped by the lock nuts on the adjustment bolts.

(6) Push back the handle. Lift out the 10 cartridges, which are now linked together, and place the left-end cartridge in the right-end groove. Place additional links and cartridges in the guides and repeat the operations until the belt is of the desired length (fig. 40).

(7) Test flexibility of belt and for oversize links as directed in paragraph 11a(2)(d), (e), and (f).

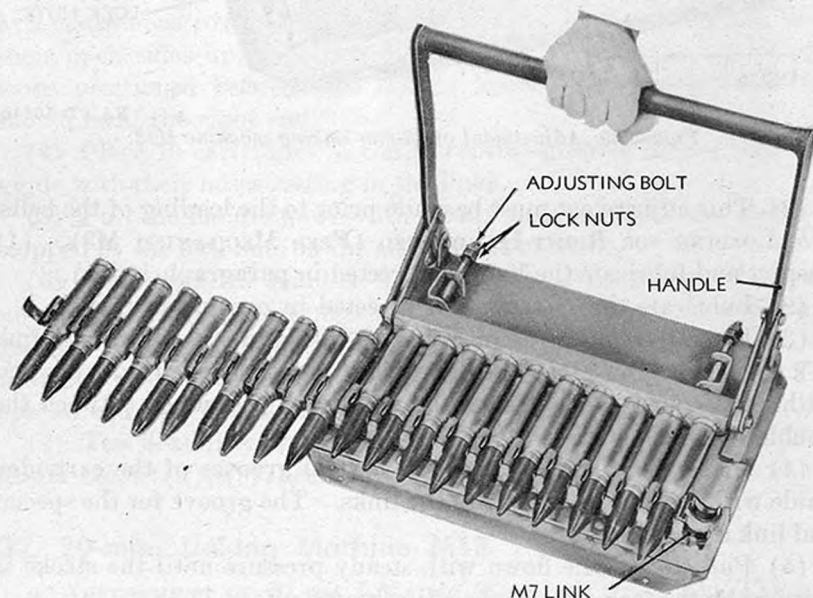

RA PD 104485

Figure 40. Belting ammunition for feed mechanism AN-M2 using 20-mm linking machine M13.

d. **LOADING FOR LEFT-HAND FEED (FEED MECHANISM M3).** (1) Inspect the links and lubricate as directed in paragraph 11a(1).

(2) Lubricate the cartridge cases as directed in paragraph 11a(1).

(3) Place 10 regular M7 or M8 type links and one special end link in a continuous row in the 10 central grooves of the link guide with their open sides up, and with double loops to the right and single loops positioned between the double loops.

(4) Place 10 cartridges in the central grooves of the cartridge guide with their noses resting in the links. The groove for the special end link must be empty.

(5) Pull the handle down with steady pressure until the stroke is stopped by the lock nuts on the adjustment bolts.

(6) Push back the handle. Lift out the 10 cartridges which are now linked together, and place the left end cartridge in the right end groove. Place additional links and cartridges in the guides and repeat the operations until the belt is of the desired length (fig. 41). The special end link should be at the right end of the complete belt.

(7) Test the belt for flexibility and for oversize as described in paragraph 11a(2), (d), (e), and (f).

e. **LOADING FOR LEFT-HAND FEED (FEED MECHANISM AN-M2).** (1) inspect the links and lubricate as directed in paragraph 11a(1).

(2) Lubricate the cartridge cases as directed in paragraph 11a(1).

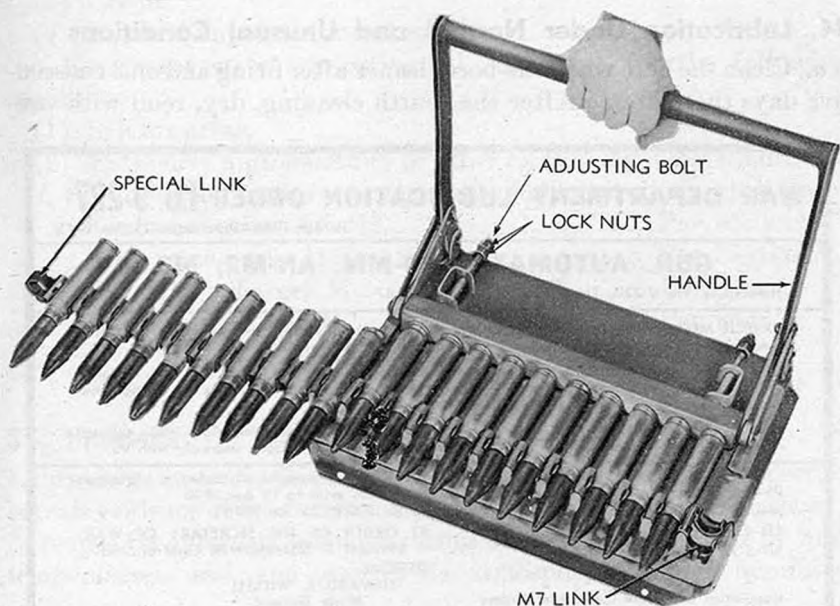

RA PD 104486

Figure 41. Belting ammunition for feed mechanism M3 using 20-mm linking machine M13.

(3) Place 11 M7 or M8 type links in a continuous row along the link guide, with their open sides up, and with double loops to the left and single loops positioned between the double loops.

(4) Place 10 cartridges in the 10 central grooves of the cartridge guide with their noses resting in the links.

(5) Pull the handle down with steady pressure until the stroke is stopped by the lock nuts on the adjustment bolts.

(6) Push back the handle. Lift out the 10 cartridges which are now linked together and place the right end cartridge in the left end groove. Place additional links and cartridges in the guides and repeat the operations until the belt is of the desired length.

(7) Test flexibility of belt and for oversize links as directed in paragraph 11a(2) (d), (e), and (f).

Section XII. LUBRICATION

33. Lubrication Order

a. Reproduction of War Department Lubrication Order LO 9-227 (fig. 42) prescribes first- and second-echelon lubrication maintenance.

b. A lubrication order is placed on or issued with each item of matériel and is to be carried with it at all times (fig. 43). In the event the matériel is received without an order, a replacement will be requisitioned in conformance with instructions and lists in FM 21-6.

34. Lubrication Under Normal and Unusual Conditions

a. Clean the bore with rifle-bore cleaner after firing and on 3 consecutive days thereafter. After the fourth cleaning, dry, recoil with pre-

WAR DEPARTMENT LUBRICATION ORDER LO 9-227	
15 Apr 1946 (Supersedes 25 Jan 1945)	
GUN, AUTOMATIC, 20-MM, AN-M2; M3.	
References: TM 9-227, TM 9-229, ORD 7 SNL A-47	
BREECH MECHANISM—Daily and after firing, clean with CR, dry, recoil with PS. In humid and salt air areas, when gun is not being fired, use PM above 0° F.	
BORE—After firing, and on 3 consecutive days thereafter, clean with CR. After 4th cleaning, dry, recoil with PM above 0° F. and wipe clean before firing. When gun is not being fired, renew oil film every 5 days. Use PS below 0° F.	
FEED MECHANISM—Weekly, or before firing, remove from gun, clean with SD. Wipe exposed surfaces with cloth moistened with PS and lubricate reciprocating parts sparingly with PS.	
PS—OIL, lubricating, preservative, special	This WDLO supersedes all conflicting lubrication instructions prior to 15 Apr 1946 [A. G. 300.8 (25 Jan 1945)] BY ORDER OF THE SECRETARY OF WAR: DWIGHT D. EISENHOWER Chief of Staff OFFICIAL: EDWARD F. WITSELL Major General The Adjutant General
PM—OIL, lubricating, preservative, medium	
CR—CLEANER, rifle bore	
SD—SOLVENT, dry cleaning	
Requisition additional Lubrication Orders in conformance with instructions and list in FM 21-6	

RA PD 108027

Figure 42. War Department Lubrication Order LO 9-227.

LO 9-227

1. DECALCOMANIA APPLICATION INSTRUCTIONS:

- a. Brush or wipe a light coating of VARNISH, spar, clear, water-resisting or LACQUER, spraying over surface to which the decalcomania is to be applied.
- b. Dip decalcomania in water until surface will separate from the backing freely, then slide decalcomania into designated position.
- c. Slide backing paper against face of decalcomania and rub surface with a light, even pressure to eliminate air bubbles.
- d. Clean around edges with SOLVENT, dry cleaning.

2. INSTRUCTIONS FOR MOUNTING:

- a. Locate on rear buffer housing.

RA PD 108028

Figure 43. Instructions for decalcomania application and mounting of lubrication order.

servative lubricating oil (medium) above 0° F. and wipe clean before firing. When gun is not being fired, renew oil film every five days. Use preservative lubricating oil (special) below 0° F.

Caution: Do not oil the bore and chamber before firing because dangerous pressures may develop.

b. Clean with rifle-bore cleaner and lubricate the following points with preservative lubricating oil (special), daily and after firing:

- (1) Breechblock group.
- (2) Receiver.
- (3) Cradle.
- (4) Exposed unpainted metal surfaces.

c. Use preservative lubricating oil (medium) for the following conditions:

- (1) Salt air areas.
- (2) Extremely high humidity or other excessively moist conditions.

d. See following paragraphs for additional lubrication instructions:

Feed mechanism AN-M2.....	Par. 81a and b.
Feed mechanism M3.....	Par. 88a and b.
Pneumatic charger M4.....	Par. 93a.
Hydraulic charger M7.....	Par. 98a.
Hydraulic charger M5.....	Par. 103a.
Manual charger M6.....	Par. 108a.

35. Intervals

Lubrication intervals should be reduced whenever the daily inspection reveals evidence of the formation of rust. It will usually be necessary to reduce the intervals when operating in areas characterized by high temperatures, dust, and sand in the atmosphere, or high humidity.

36. Methods

a. CLEANING. (1) Unless otherwise specified, use rifle-bore cleaner to clean or wash all metal parts, whenever partial or total disassembly

is undertaken, or when renewing the protective lubricant film on exposed metal surfaces. The use of gasoline is prohibited.

(2) Care must be taken when cleaning internal mechanisms to insure complete removal of all residue or sediment. Necessary wiping should be done with a piece of firm, lintless cloth. Dirt or other foreign matter should not be allowed to get into the lubricant and lubricating openings.

b. LUBRICATION. Lubricant should be applied while the parts are being operated by hand to insure proper distribution of lubricant to all moving parts. Because of the extremely low temperatures prevailing at high altitudes, apply only a thin film of lubricant before flights. At other times, apply lubricant freely but avoid excessive and wasteful practices. Excessive lubrication will result in dust accumulations on some moving parts and cause wear and malfunctioning.

Section XIII. PREVENTIVE MAINTENANCE SERVICE

37. General

Preventive maintenance services prescribed by Army Regulations are a function of using organizations echelons of maintenance. This section contains preventive maintenance service allocated to crew (first-echelon) and scheduled preventive maintenance service allocated to organizational (second-echelon) maintenance.

38. Operational Inspection

The following general points will be carefully noted in the inspection of the matériel:

a. Inspect all operating mechanisms for ease of operation, backlash, and sufficient lubrication.

b. At least every 6 months make a check-up to insure that all modifications have been applied. A list of current Modification Work Orders is published in FM 21-6. If a modification has not been applied, the local ordnance officer will be promptly notified. No alteration or modification which will affect the moving parts will be made by the using personnel, except as authorized by the Ordnance Department.

c. Inspect safety features for functioning.

d. Check whether lettering on name plates and direction plates of feed mechanisms are legible.

e. Inspect covers of weapon.

f. Inspect accessories, tools, spare parts, and equipment for completeness and serviceability.

g. Check weapon for damage or deterioration of paint.

h. Whenever the items are disassembled, check all springs listed

below for free length, kinks, and breaks. Replace springs that are broken or kinked or whenever free length is less than the allowable free length.

	<i>Free length (inches)</i>	<i>Allowable free length (inches)</i>
Gun:		
Breechblock slide spring-----	2.87	2.58
Driving spring-----	26.5	23.5
Ejector spring-----	1.89	1.70
Gas cylinder sleeve spring-----	5.60	5.04
Magazine latch spring-----	2.83	2.54
Sear buffer spring-----	1.89	1.70
Feed mechanism M3:		
Operating lever springs-----	1.218	1.09
Round retaining finger spring-----	1.187	1.06
Pneumatic charger M4:		
Piston return spring-----	26	23.4
Head return spring-----	8.75	7.87
Manual charger M6:		
Slide return spring-----	14	12
Spring (for latch locking ball)-----	.406	.366
Hydraulic charger M7:		
Piston return inner spring-----	22.5	20
Piston return outer spring-----	23	20.5
Hydraulic charger M5:		
Piston return spring-----	22	20
Electric trigger AN-M1A1:		
Sear return spring-----	.92	.83
Electric trigger AN-M4:		
Solenoid spring-----	1.156	1.04

39. Common Preventive Maintenance Procedures

a. The general preventive maintenance outlined below will be observed in addition to that referred to in the schedules listed in paragraph 40.

b. Do not dip or wash assemblies containing ring springs in dry-cleaning solvent. These units are lubricated by the manufacturer and if this special lubricant is diluted with cleaning solvent, early failure of the unit will result.

c. Rust, dirt, grit, gummed oil, and water cause rapid deterioration of internal mechanism and outer unpainted surfaces. Particular care should be taken to keep all bearing and sliding surfaces clean and properly lubricated. All traces of rust should be removed with crocus cloth.

d. Loose parts will be tightened; broken parts will be replaced; and

lock washers, safety wire, cotter pins, and other locking devices will be properly applied.

e. Most of the parts on this weapon are finished by the Parco-Lubrite process. The resistance of this type of finish to corrosion is greatly enhanced by the application of a light coat of oil. Accordingly, a light coat of oil will be maintained on all "Parco-Lubrited" parts.

f. Use only the tools that are provided and see that they fit snugly on parts. Tools that do not fit will fail or cause damage to parts. Accessories, tools, and spare parts will be inspected for serviceability. Missing or damaged items will be replaced or turned in for repair.

40. First- and Second-Echelon Maintenance Schedules

a. GENERAL. The items or points to be inspected and serviced at scheduled times are listed below with cross references to detailed instructions in other paragraphs in this manual.

b. DAILY.

<i>Point</i>	<i>Preventive maintenance</i>	<i>Detailed instructions</i>
Bore-----	Check for rust and/or fouling.	Clean and oil if necessary (pars. 34a and 63d).
Gun-----	Check for rust and cleanliness.	Clean and oil if necessary (pars. 34b and 64b).
Feed mechanism---	Check for rust and cleanliness.	Clean and oil if necessary (pars. 81 and 88).
Chargers-----	Check for rust and cleanliness.	Clean and oil if necessary (pars. 93, 98, 103, or 108).

c. BEFORE FIRING.

<i>Point</i>	<i>Preventive maintenance</i>	<i>Detailed instructions</i>
Barrel and receiver.	Clean and oil-----	Pars. 63d and 64b.
Feed mechanism AN-M2.	Lubricate-----	Par. 81.
Feed mechanism M3.	Lubricate-----	Par. 88.
Magazine slide (feed mechanism AN-M2).	Dynamic torque test.	Par. 86m.
	Check alinement of engraved lines on slide and receiver.	Par. 12a.
	Check operation of latch.	Operate latch and lubricate.

<i>Point</i>	<i>Preventive maintenance</i>	<i>Detailed instructions</i>
Feed slide (feed mechanism M3).	Check alinement of engraved lines on slide and receiver.	Par. 13a.
Magazine slide anchors.	Check for tightness of nuts.	Pars. 12a and 13a.
Trigger-----	Check for operation--	Connect trigger to 24-volt source and actuate. If sear trips, mechanism may be considered serviceable.
Charger-----	Check for operation--	Actuate and note operation. If breechblock is cocked, mechanism may be considered serviceable.
	Lubricate (manual charger M6).	Put a drop of oil on swivel head and pulley.
Heater-----	Check for operation--	Connect to power source and note if all three heating units heat properly.

d. AFTER FIRING.

<i>Point</i>	<i>Preventive maintenance</i>	<i>Detailed instructions</i>
Breechblock-----	Remove, disassemble, clean, and oil.	Par. 70a.
Bore-----	Clean-----	Par. 63d.
Gas cylinder and sleeve group.	Clean and inspect---	Remove any carbon deposit. Make certain gas ports in tube and in vent plug are open. Check gas cylinder sleeve spring for breakage. Par. 74b.
Gun in general-----	Inspect for broken and loose parts, proper adjustments, etc.	
Charger-----	Check for operation.	
Flash hider-----	Check for tightness.	

<i>Point</i>	<i>Preventive maintenance</i>	<i>Detailed instructions</i>
Feed mechanism---	Clean and lubricate-- Inspect-----	Pars. 81 and 88. Pars. 81 and 88.
Trigger-----	Inspect and check operation.	Examine for loose or broken parts. Con- nect trigger to power source to see if it will trip sear.
Heater-----	Clean and check oper- ation.	Wipe any foreign mat- ter from heater with a clean cloth. Con- nect heater to a power source and check to see that all elements heat up properly.

Section XIV. GENERAL ORDNANCE MAINTENANCE

41. Inspection and Testing

a. Every gun received by ordnance maintenance personnel for rebuild will be thoroughly and completely inspected, put into the best possible condition that time, materials, and technical circumstances will allow, and returned to the using arm ready for immediate use.

b. Note the general appearance, check for rust formation, and inspect for missing bolts, nuts, locking devices, and wires. Check visually for cracks, breaks, or deformed parts. Check cradle mounting plate by lifting the gun while it is still in the cradle. Inspect anchor support brackets for proper tension of screws.

c. Cock the bolt and connect the electric trigger to a 24-volt direct current power supply. The sear action should be instantaneous. If the sear is not tripped, and it is known that the solenoid was energized, remove the solenoid and determine the effort required to trip the sear. This should not require more than 50 pounds. Inspect the locking surfaces of both the sear and the breechblock. Scores, mutilation, or a defective sear plunger and spring would cause excessive firing effort.

d. With the bolt and rear buffer removed, clean the bore and examine the rifling. Excessive wear, serious erosion, or deformation of the tube would be cause for its rejection. Examine the chamber for scores and burs. Failure properly to extract and eject the cartridge can be caused by a scored chamber or a faulty extractor. The average life of a tube under favorable conditions is approximately 5,000 to 6,000 rounds. With the bolt retracted, inspect the breechblock locking key and the receiver slides. The key must not be loose or show signs of any mutila-

tion. Excessive wear on the key will cause excessive headspace between the cartridge case and the face of the breechblock. Loose or scored receiver slides will cause binding of the bolt action and reduce the firing speed of the gun.

e. With the breechblock in its forward position, use a feeler gage to check the clearance between the push rods and gas cylinder sleeve yoke. The clearance should not be more than 0.042 inch and should check the same on both sides with 0.003 inch. If greater difference is found, it indicates a sprung yoke on the gas cylinder sleeve, mushroomed push rods, or defective breechblock slides. These conditions must be remedied, or a binding action may develop in the bolt. Inspect the gas cylinder sleeve for straightness. A bent sleeve will cause an apparent difference in the length of the push rods.

f. Test the slide to determine ease of operation. Inspect the ejector for wear. Worn or damaged ejectors will cause rounds to position improperly in the feed mouth. Cartridge cases will not eject properly if ejector is loose or out of position in the magazine slide. Test the action of the magazine slide latch and lever assembly. The latch should operate smoothly with a positive action.

g. Inspect the cradle for damaged or loose brackets. Any play in screws or rivets in this member will soon develop into a serious condition. Trunnion blocks must be secure on the mounting brackets. Any play between blocks and the trunnions will necessitate replacement of the worn part.

h. Visually inspect the adapter assembly. Never use dry-cleaning solvent or vapor degreasing methods on gun adapter. Check for broken recoil springs or damaged parts. Inspect the condition of the trunnion on either side of the recoil housing.

i. If the gun is equipped with the feed mechanism M3, close the loading switch and watch the action of the feed mechanism. Raise the stripper cover and inspect the feed wheels, link stripper, and loading levers for wear or damage. Check the tension of the loading lever springs. The feed mechanism AN-M2 should be inspected in a similar manner, except that it cannot be operated without rounds being in place. Inspect the condition of the stripper cams and link chute. Check the tightness of screws holding the operating lever bracket to the cradle. Inspect the operating link assembly for missing cotter pins or loose nuts.

j. Turn on the current supply and test the heating elements. Inspect the wiring connections and terminals.

k. Test the charger, making certain that all connections are tight; loose connections will prevent chargers from operating correctly.

l. Report to the responsible officer any pertinent carelessness or negligence in the preventive maintenance procedures and safety pre-

cautions. This report should be accompanied by recommendations for correcting the unsatisfactory conditions.

42. Common Ordnance Maintenance Procedures

a. GENERAL. The general procedures given below should be followed during repair and rebuild operations:

(1) Assemble subassemblies and groups before mounting them on the gun. As a part of all assembly and mounting operations, clean and lubricate the threads, slide surfaces, and mating parts.

(2) When assembling the gun, use new cotter pins, locking plates, and locking wire, tied or fastened in an approved manner. In checking for cracks, it is recommended that magnaflux equipment be used if available.

(3) Remove all burrs from sliding surfaces with a fine oil stone and polish with crocus cloth. Thoroughly wash off all abrasive with dry-cleaning solvent.

(4) Remove all burrs from threads by chasing with the proper size taps or dies if available. (Most threads on this gun are metric sizes.) Following is a list of thread sizes of parts which may require cleaning:

Item	Ordnance No.	Pitch
Anchor, magazine slide.....	B7226812.....	5/16-24NF-2.
Bracket, gas cylinder.....	B7226814.....	10-mm-1.5-mm Int. Form.
Bracket, mounting.....	C7226810.....	3/8-16NC-2.
Cylinder, gas.....	B163311.....	14-mm-1.5-mm Int. Form.
Guide, gas cylinder.....	A25582.....	20-mm-1.5-mm Int. Form.
Head, driving spring guide.....	B7231159.....	
Outer end.....		5/8-18NF-2.
Inner end.....		25-mm-1.5-mm Int. Form.
Key, breechblock locking.....	B7226047.....	3/8-24NF-3.
Plug, gas cylinder bracket.....	B163320.....	10-mm-1.5-mm Int. Form.
Plug, gas cylinder vent.....	B7229626.....	14-mm-1.5-mm Int. Form.
Receiver.....	D7226842.....	
Hole to receive tube.....		52-mm-2.5-mm Int. Form.
Hole for gas cylinder sleeve guide.....		20-mm-1.5-mm Int. Form.
Holes for securing M6 man- ual charger.....		0.190 (No. 10)-32NF-2.
Holes to attach M1 heater.....		0.190 (No. 10)-32NF-3.
Holes for attaching operat- ing lever bracket of AN- M2 feed mechanism.....		5/16-24NF-2.
Holes to attach electric trig- ger.....		7-mm-1-mm Int. Form.
Slide, magazine.....	C70497.....	7-mm-1-mm Int. Form.

b. FUNCTION TESTING. (1) Place the gun in a suitable fixture and fasten it securely. Have gun properly lubricated. Cock the bolt. The bolt should retract properly with the charger mounted in either the right- or left-hand position. Connect the electric trigger to a suitable source of 24-volt direct current power to test the action of the breechblock and sear. The bolt should go forward to battery position and lock. Any malfunction observed would be due to improperly fitted breechblock components or a faulty electric trigger; therefore, the "dry-firing" test is of utmost importance. Check the position of the magazine slide on the receiver by observing scribed lines. Adjust the anchor rod to have the center pair of scribed lines coincide. This adjustment is very important. Be sure adjusting nuts and lock nuts on the anchor are tightly secured after alinement is attained.

(2) Install a feed mechanism on the gun. If the AN-M2 type is to be used, make up a belt of dummy rounds (sec. XI). Install feed chute adapter and ammunition chute to feed mechanism. Install the belt into the feed mouth with an empty, single-loop leading. Wind the feed mechanism spring the full amount, by turning the main drive shaft from the front end, using a wrench on the hex end. This action draws the rounds down into the feed pawls and stops the first round in contact with the top of the bolt. Operate the bolt several times with a charger to test the action of the stripper cams, cartridge pawls, and positioning of rounds in the feed mouth. During this operation keep sufficient tension on the feed spring to simulate actual gun operation. Notice the action of ejector and extractor at this time.

(3) Install feed mechanism M3 on the gun. Make up a belt of dummy rounds (sec. XI). Lift the stripper cover and start a belt of rounds into the feed wheel. Close the stripper cover and secure with the pins. Connect feed mechanism motor to a 24-volt direct current power supply and operate the bolt with a charger to test the stripping and feeding action.

Note.—Many malfunctions and jams of the gun and feed mechanism can be caused by faulty or misformed links.

c. FUNCTION FIRING. (1) In order to function fire this weapon a sufficiently sturdy stand must be available to mount the gun. An opening must be situated within the top of the stand, large enough to permit empty cartridges to be ejected. Fasten the cradle securely to this stand in four places. Position the gun and stand to have projectiles hit in a pit or bank. Clean the bore and chamber. Make sure all assemblies are properly adjusted and secured.

(2) When function firing a gun equipped with a feed mechanism AN-M2, make up a belt of 25 or 30 M1 ball or 24 practice cartridges (sec. XI). By hanging the belt of approximately 30 rounds from the feed mouth, a suitable drag will be developed which will determine the

condition of the driving mechanism spring assembly until the clutch slips. Insert the end of the belt into the feed mouth and wind the driving mechanism assembly until the clutch slips. Position the feed operating lever in the bracket on the receiver and make sure the latch is holding the lever in place. Charge the gun and when the charging lug has returned to the forward position, fire a short burst to see that the gun recoils properly, ejects cartridges properly, and strips links without jamming. Fire a burst of 10 or 15 rounds to test for any similar malfunction. The rate of fire should not be below 650 rounds per minute. Fire the remaining ammunition in short bursts to test driving mechanism winding assembly. In case of a jam, do not attempt to remove the feed mechanism without unwinding the main drive shaft spring. (See par. 16a.)

(3) When function firing a gun equipped with a feed mechanism M3, make up a belt of 25 or 30 M1 ball or T24 practice cartridges (sec. XI). Recheck alinement marks on receiver and magazine slide. Raise the stripper cover, insert the first round between the feed wheel fingers, and close the cover, securing it with the locking pins. Have the bolt in a forward position. Connect the feed motor to an electrical power source to feed the ammunition belt into the mechanism until the first round rests on top of the breechblock. Draw the bolt back with the charger and allow sufficient time for the charging lug to return to its free position. Fire a few short bursts to test the trigger action and the recoil action, and note particularly whether links and cartridge cases drop free of the gun. Fire a burst of 10 or 15 rounds. Watch feed mechanism closely to determine any malfunction or slipping. If lag occurs, feed wheel clutch tension must be checked and tightened if found lower than 180 inch-pounds. Continue firing to exhaust all rounds in feed mechanism. Check rear buffer carefully while function firing tests are in progress. The buffer housing will heat up if the springs are broken. Check for pieces of loose metal inside buffer housing as an indication of broken springs or sleeves.

(4) In the event a "dud" is encountered, extract it from the gun with the charger and examine the primer. Light struck primers denote a faulty firing pin, broken or weak driving spring, or a fouled breechblock due to burnt powder or metal chips being built up inside the firing pin hole. If the indentation in the primer appears deep enough, the round can be considered faulty.

Section XV. CYCLIC FUNCTIONING OF WEAPON

43. General

The cyclic functioning of the weapon as a whole, from the firing of one round to the next, is described in the following paragraphs. For

purposes of explanation, the cyclic functioning is divided into the following actions:

- a.* Recoil action (par. 44).
- b.* Breechblock unlocking action (par. 45).
- c.* Extraction and ejection (par. 46).
- d.* Rear buffer and driving spring action (par. 47).
- e.* Cocking action (par. 48).
- f.* Feeding and chambering (par. 49).
- g.* Breechblock locking action (par. 50).
- h.* Firing action (par. 51).

44. Recoil Action (Fig. 44)

a. When the round is fired, the pressure of the propellant gases in the tube forces the gun to recoil to the rear for about 1 inch. As the gun recoils, the recoil spring front seat and the gun tube move to the rear and compress the recoil spring. Since the compression of the ring spring in the recoil housing assembly is greater than the final force of the recoil spring, it can thus be seen that during this phase of the recoil, the recoil spring alone will offer resistance to the rearward movement of the gun. This action will continue until the gun has recoiled for about $\frac{7}{8}$ inch. At this point, the rear end of the recoil spring front seat contacts the front end of the recoil spring rear seat, thus stopping the compression of the recoil spring. While the recoil spring rear seat begins to compress the ring spring of the recoil housing assembly which absorbs the remaining shock of recoil, the recoil spring begins to recover. The recovery of the recoil spring returns the gun into battery.

b. The ring spring of the recoil housing assembly will act as a counterrecoil buffer if the gun should travel past its battery position. The ring springs will be compressed in the same manner as during recoil movement of the gun, but the action of the parts will be reversed.

45. Breechblock Unlocking Action

a. The breech is unlocked by the action of the gas cylinder sleeve group. At the moment of firing, the breechblock is held in its forward position by the action of the breechblock lock. The lock engages the breechblock at point "A" (fig. 45) and bears against surface "B" (fig. 45) of the breechblock key. The breechblock slide engages the lock at point "C" (fig. 45), thus preventing the lock from being forced upward prematurely.

b. As the round is fired, the projectile is driven forward in the tube, passing the gas port (fig. 46). A portion of the expanding gases enters the gas port and passes through the gas cylinder vent plug into the gas cylinder (fig. 46). As the gas expands against the

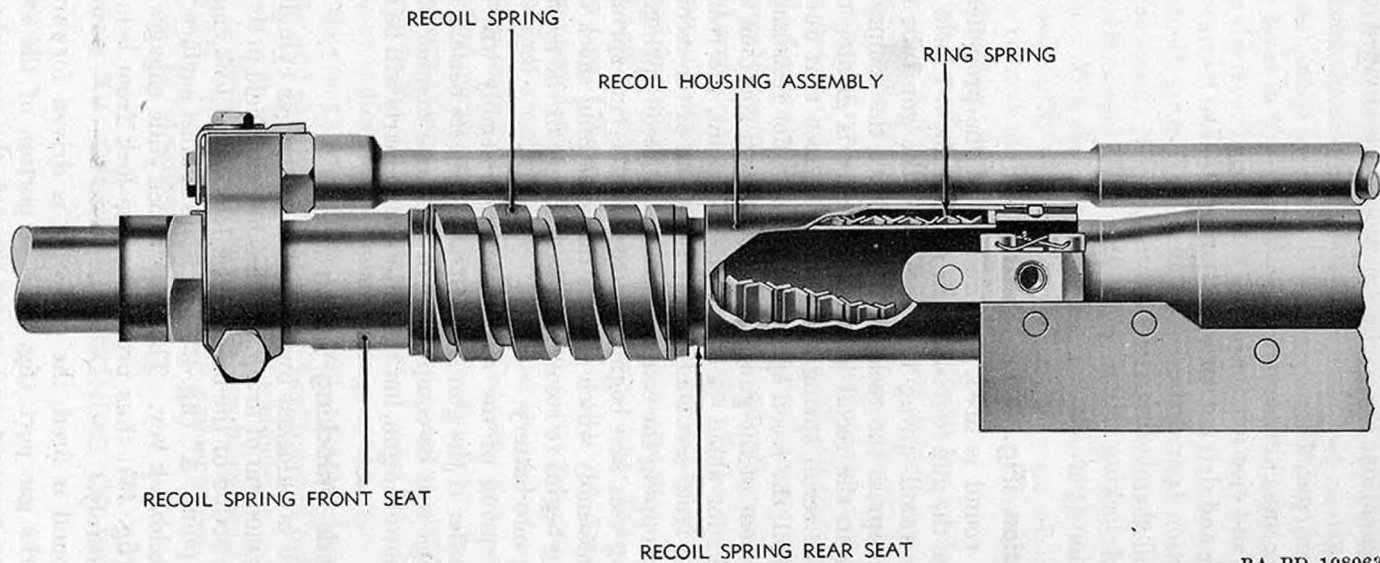
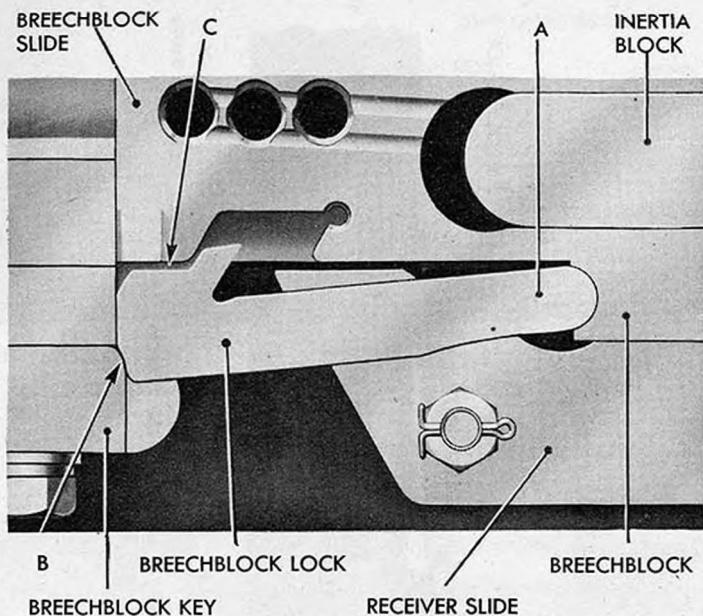

Figure 44. Action of recoil spring and ring spring.



RA PD 94007

Figure 45. Breechblock lock in locked position at moment of firing.

gas cylinder piston, it forces the piston and the gas cylinder sleeve (integral with it) to the rear, compressing the gas cylinder spring (fig. 46).

c. As the sleeve is forced to the rear, the yoke on the sleeve contacts the two push rods which, in turn, move the breechblock slides rearward to unlock the breechblock (fig. 47). The slides are connected to the slide key which engages a slot in the bottom of the firing pin. As the slides are forced rearward by the push rods, the key retracts the firing pin. The moment the breechblock is unlocked (fig. 47), it is forced to the rear by blowback action with a resultant drop of gas pressure in the tube. As the gas pressure drops, the gas cylinder sleeve spring expands, returning the sleeve and piston to the original position.

46. Extraction and Ejection

When the breechblock assembly is forced to the rear, the empty cartridge case, which has been forcing the bolt back by blowback action, is contacted on the upper edge by the two prongs of the ejector (fig. 48), forcing the cartridge case to pivot about and force downward the forward end of the extractor. The cartridge case leaves the lip of the extractor and moves through an opening in the bottom of the receiver, completing the ejection of the empty cartridge case (fig. 48). When the cartridge case frees itself from the extractor, the extractor is returned to its normal position by the action of the extractor spring.

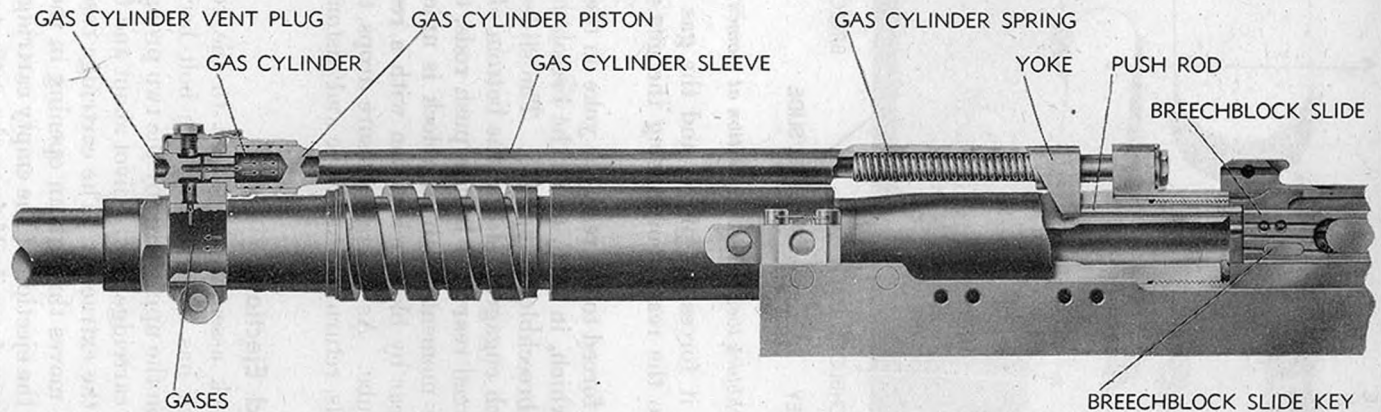

RA PD 94072

Figure 46. Action of gas cylinder sleeve group for unlocking the breech.

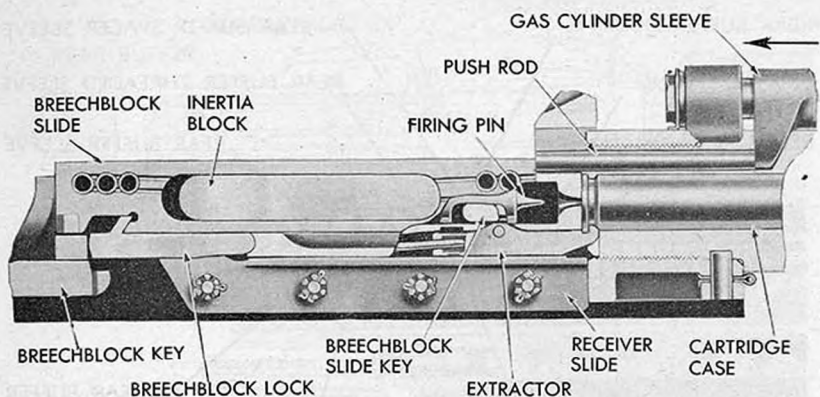

RA PD 94005

Figure 47. Unlocking of breechblock and retraction of firing pin.

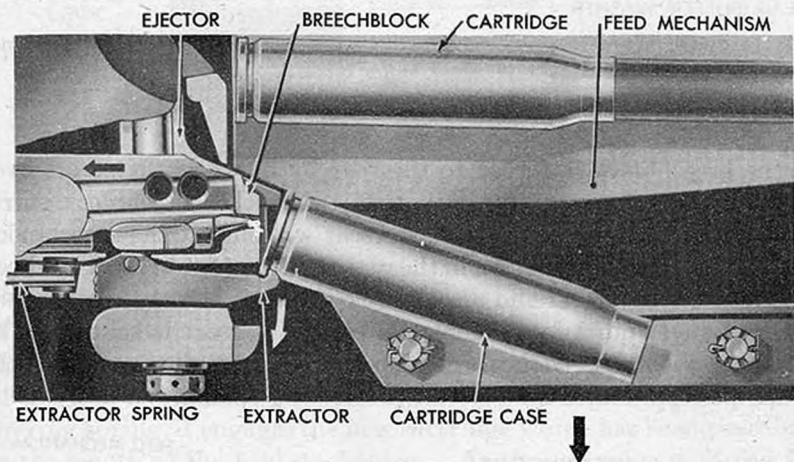

RA PD 94120

Figure 48. Ejection of cartridge case.

47. Rear Buffer and Driving Spring Action

As the breechblock is driven rearward, it compresses the driving spring. When the breechblock nears the end of its rearward movement, it strikes the rear buffer washer which transmits the shock of recoil to the buffer springs which absorb the remaining force of recoil and bring the breechblock to a stop (fig. 49). As the breechblock comes to a stop, the inertia blocks continue to move rearward in their slots in the breechblock slide until they reach the end of the slots. By this time the breechblock has started forward again, and the inertia blocks remain in a rearward position with respect to the breechblock slides during the forward motion of the breechblock. The rear buffer springs and the driving spring expand, forcing the breechblock forward (fig. 49).

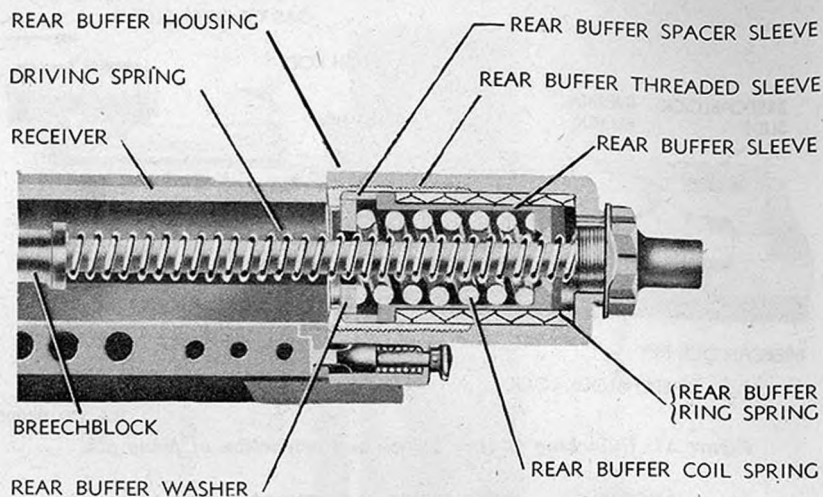

RA PD 94000

Figure 49. Rear buffer cross section.

48. Cocking Action

As the breechblock is forced to the rear by blowback, it passes over and depresses the sear (fig. 50), then, when the breechblock starts forward, and the sear is released, the sear will engage the breechblock lock and hold the breechblock in the rear position (fig. 51). The shock produced when the sear and breechblock engage is absorbed by the sear buffer springs and the sear buffer plates. If the sear is held down by actuating the trigger, the breechblock will move forward into the locked position under the force of the driving spring.

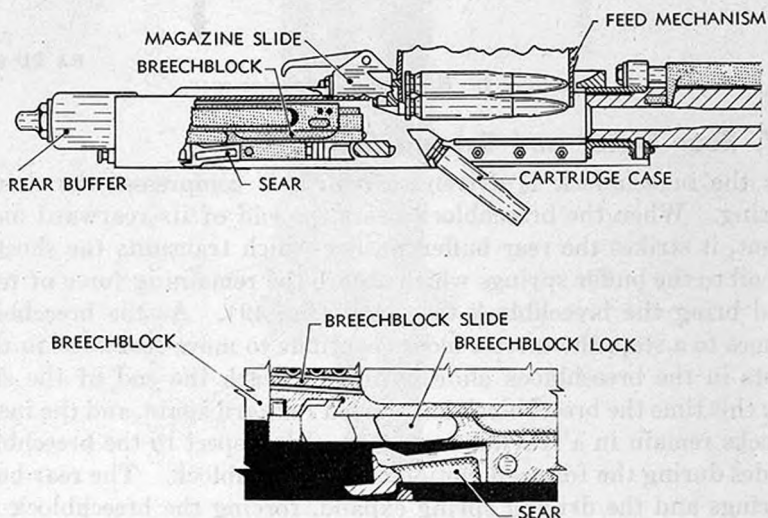

RA PD 94016

Figure 50. Action of sear during recoil of breechblock.

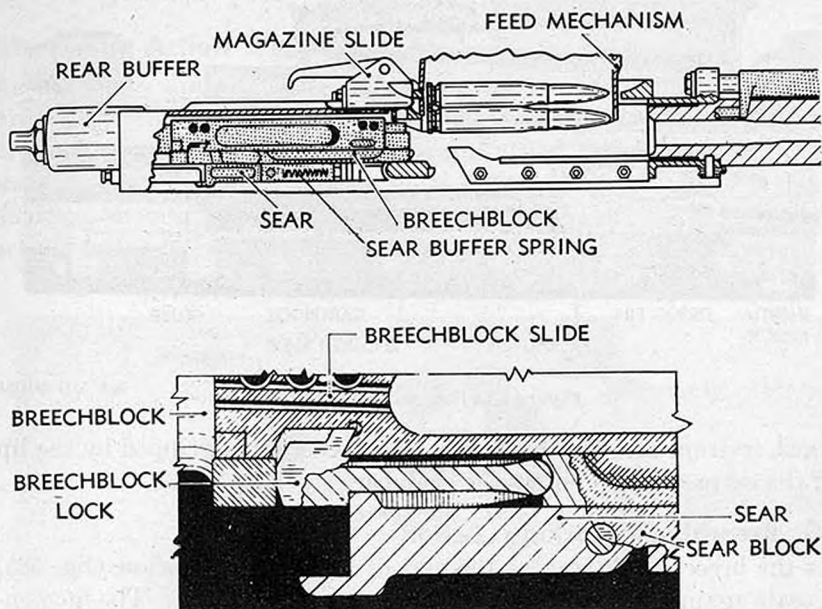

RA PD 94017

Figure 51. Engagement of sear and breechblock during counterrecoil of breechblock.

49. Feeding and Chambering (Figs. 52 and 53)

When the recoiling breechblock is sufficiently far to the rear to clear the feed mechanism, a new round is forced downward into the mouth of the feed mechanism. As the breechblock is forced forward by the driving spring, it engages the new cartridge which has been positioned in the mouth of the feed mechanism. As the cartridge is forced for-

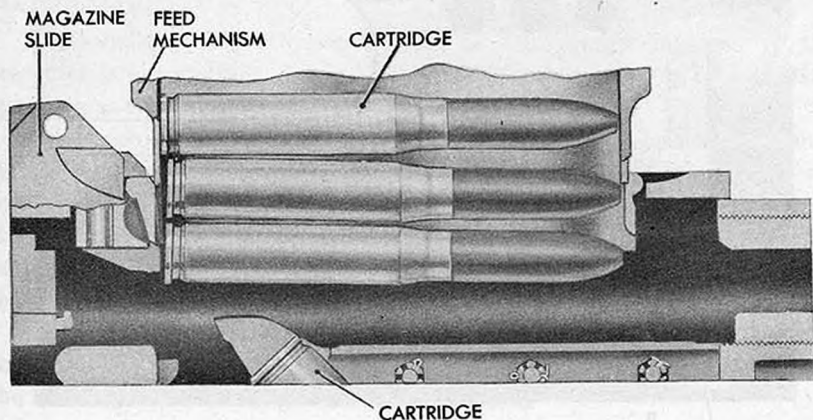

RA PD 93955

Figure 52. New round being forced downward into mouth of feed mechanism.

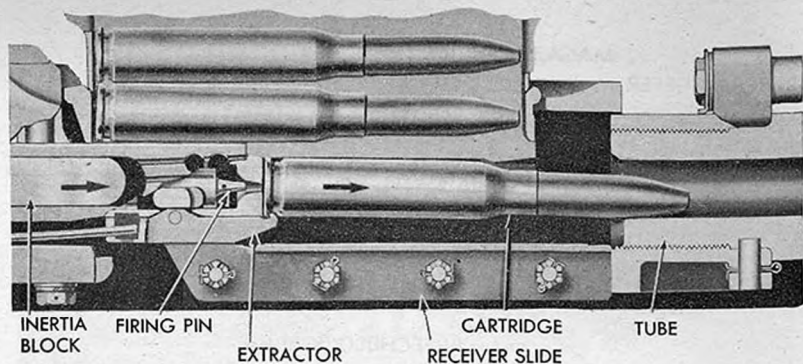

Figure 53. Ramming of a round.

RA PD 94036

ward, it drops into the recess in the bolt where it is gripped by the lip of the extractor as it enters the chamber.

50. Breechblock Locking Action

As the breechblock reaches the end of its forward motion (fig. 58), it seats against the end of the tube, closing the chamber. The momentum of the slides and the action of the slide springs cause the slides to continue to move forward, releasing the breechblock lock. At the same time, projecting cams (A, fig. 54) of the lock are engaged by cam surfaces on the receiver slides which, together with the action of the cams on the bevel of the lock, cam the lock downward. The lock seats against the breechblock key and is locked in its downward position by the lower surface of the breechblock slides (B, fig. 54) which move over the rear end of the lock.

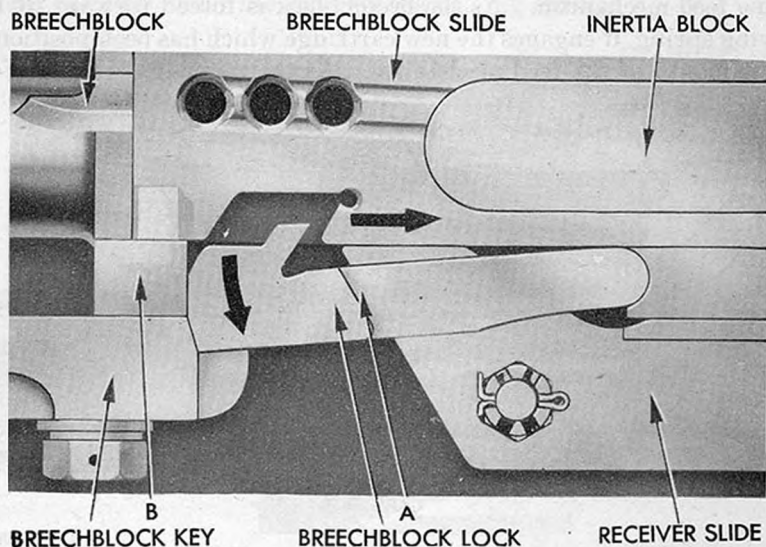

Figure 54. Breechblock in locked position.

RA PD 94008

51. Firing Action (Fig. 55)

As the slides approach the end of their forward motion, the firing pin is carried forward by the slide key and the driving spring to fire the round. When the slides have reached the end of their forward motion, the inertia blocks continue to move forward for a short distance, striking against the forward end of the slot, thereby counteracting any tendency to rebound that the slides or pin might have.

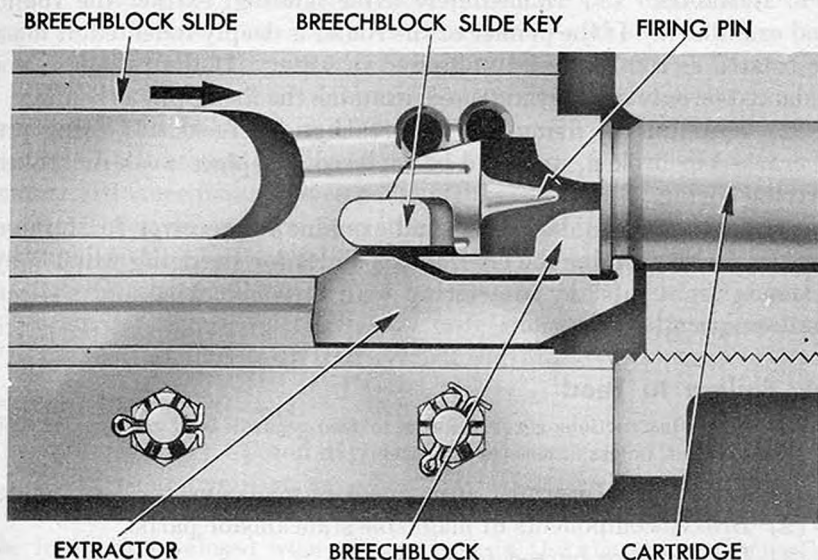

Figure 55. Firing pin moving to fire round.

RA PD 26984

Section XVI. MALFUNCTIONS AND CORRECTIONS

52. Misfire

a. GENERAL. All stoppages will be considered misfires if the receiver is not visible. Immediately after the occurrence of a misfire, proceed as instructed in *b* and *c* below.

b. GROUND TESTING. Wait 30 seconds from the time of occurrence of the misfire. Recharge the gun and remove the round from the vicinity of the aircraft. **Caution:** If the gun is hot and the round cannot be removed from the chamber, the breechblock should be closed. It should not be opened until the hand can be placed on the breech or barrel without discomfort.

c. AIR TESTING. If the weapon can be recharged, either manually or remotely, wait 30 seconds and then recharge. If the weapon cannot be recharged, no corrective action is possible.

Note. The possibility of a hangfire of more than 30 seconds after an attempt to fire is very remote in guns using fixed ammunition. The possibility of the propellant or the high-explosive filler being fired by the heat absorbed from a hot

gun barrel increases with the length of time the round is in the gun. The safest time to remove a misfire is between 30 to 45 seconds after its occurrence.

53. Failure to Fire Chambered Round

- a. CAUSES. (1) Defective firing pin.
(2) Defective ammunition.
(3) Weak or broken driving spring.

b. REMEDIES. (1) Immediately after landing, extract the round and examine it. If the primer of the round is deeply indented, it must be treated as a misfire and immersed in water. If the primer is not indented or only slightly indented, examine the firing pin as below.

(2) Examine the firing pin for breakage or cracks. If firing pin is cracked or broken, it should be replaced. Replace weak or broken driving spring.

(3) Inspect the slide springs and examine the receiver for foreign matter. Also examine the breechblock slides for swedging which may produce "light hits" by interfering with breechblock action. Clean and remove all obstructions.

54. Failure to Feed

Note. These instructions cover failures to feed regardless of the type of feed mechanism used, unless otherwise indicated.

- a. CAUSES. (1) Improper adjustment of magazine (or feed) slide.
(2) Broken components of magazine slide anchor parts.
(3) Deformed or burred feed mouth.
(4) Excessive friction in feed mechanism.
(5) Broken belt or belt jam in ammunition box or feed chute.
(6) Link jam in link chute.
(7) Insufficient recoil of breechblock caused by faulty unlocking or defective ammunition.
(8) Insufficient voltage (feed mechanism M3).
(9) Faulty electrical connections (feed mechanism M3).
(10) Defective electric motor (feed mechanism M3).
(11) Clutch not adjusted (feed mechanism M3).
(12) Loss of tension of driving spring (feed mechanism AN-M2).

b. REMEDIES. (1) Adjust magazine (or feed) slide correctly. (See pars. 12a and 13a.)

(2) Tighten loose components and replace broken components of magazine slide anchor parts.

(3) Remove all burrs from feed mouth, using a fine oilstone or crocus cloth. If mouth is deformed, feed mechanism should be replaced.

(4) Check movement of operating parts and, if friction is excessive, lubricate.

(5) Check ammunition box and feed chute for jammed links or rounds. Replace defective links, rounds, or feed chutes, if necessary.

(6) Check for jammed links in link chutes. Remove jammed links.

Caution: To avoid injury, do not insert finger into adapter of feed mechanism AN-M2 to remove a jammed link.

(7) If gun fails to pick up a new round, proceed as follows:

(a) Adjust magazine (or feed) slide correctly. (See par. 12a or 13a.)

(b) Check bore to see that there is no round in the chamber.

(c) Check gas cylinder sleeve and piston for free operation. (See par. 74.) Remove burrs and dirt from piston and sleeve. (See par. 74.) If piston is deformed or bent on the end, replace it.

(d) Remove burrs from breechblock and from interior surfaces of receiver. (See pars. 64b and 70a.)

(8) Check voltage; if insufficient to operate feed mechanism M3, notify ordnance maintenance personnel.

(9) Check wiring for proper connections and grounding (feed mechanism M3).

(10) Check operation of feed mechanism M3. If electric motor does not function properly, notify ordnance maintenance personnel.

(11) Adjust clutch of feed mechanism M3. (See par. 86g.)

55. Failure to Extract

a. CAUSES. (1) Carbon deposit in chamber.

(2) Dirty ammunition.

b. REMEDIES. (1) When failure to extract occurs, the bolt may be found fully closed with a spent case in the chamber. Generally, most failures to extract can be remedied by charging the gun, except when the extractor, extractor spring, or extractor pin are broken. When this occurs, the case should be pushed out from the muzzle end. The broken extractor, spring, or pin should be replaced.

(2) Sometimes the empty case will be left in the chamber with the extractor ripping through the base of the cartridge case. When this occurs, the bolt will generally attempt to feed a fresh round into the chamber. It will then be necessary to remove this round before the spent case can be removed. If the jammed round is broken, be sure to remove all powder that may be strewn around in the receiver.

(3) A dirty chamber can be caused by carbon deposit from the oil film on the rounds. If this occurs, clean the chamber.

56. Failure to Eject

a. 20-MM FEED MECHANISM AN-M2. (1) Causes. (a) Broken ejector stud.

(b) Broken ejector.

(2) Remedy. Replace the ejector. (See par. 66.)

b. 20-MM FEED MECHANISM M3. (1) Cause. Broken ejector.

(2) Remedy. Replace the ejector. (See pars. 85b and 86k.)

57. Run-Away Gun

- a. CAUSES. (1) Defective firing switch (if used).
(2) Broken sear or broken and weak sear spring.
(3) Jamming of solenoid plunger in sleeve (AN-M1A1 trigger).
- b. REMEDIES. (1) If firing switch (if used) is defective, notify ordnance maintenance personnel.
(2) If sear or sear spring is broken, replace.
(3) If solenoid plunger jams, replace trigger.

58. Slow Firing Gun

If the gun fires at a rate of below 650 rounds per minute, it should be turned over to ordnance maintenance personnel.

Section XVII. CRADLE GROUP

59. General (Fig. 56)

a. The cradle assembly is the actual mount for the gun. It is so designed that it will allow the gun to move backward in recoil and forward in counterrecoil. The nonrecoiling recoil housing assembly of the gun, which fits around the recoiling gun tube, is secured to the mounting bracket of the cradle by means of two trunnion blocks and four trunnion block and mounting bracket screws safetied by a plate, the corner of which is bent up. The receiver, which is recoiling, engages one horizontally rotating roller and two vertically rotating rollers at the rear of the cradle. The rollers carry the weight and control the vertical movement of the gun.

b. The cradle also mounts the anchor support bracket to which the

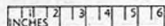
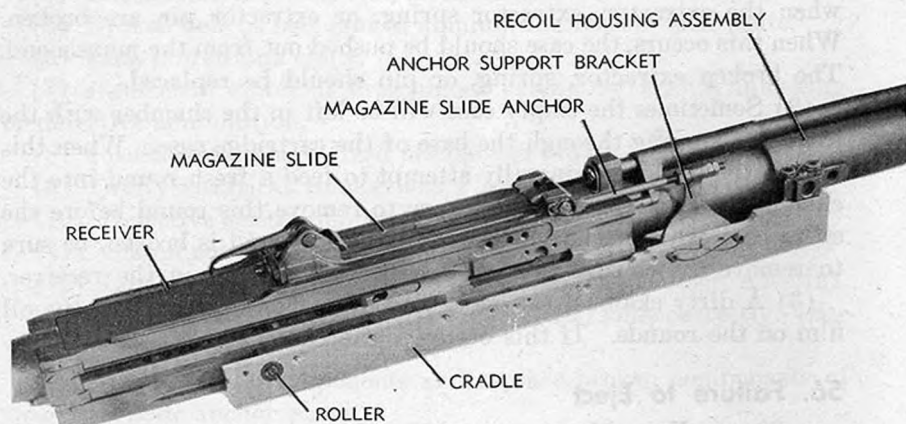

Figure 56. Cradle (assembled to gun).

RA PD 108065

magazine slide is fixed by means of a magazine slide anchor. In this manner the magazine slide is made nonrecoiling, whereas the receiver, on which it is mounted, recoils during firing. This condition is utilized in the operation of the 20-mm feed mechanism AN-M2 which is recoil operated.

c. The sides of the cradle have drilled and tapped holes for mounting the various chargers.

60. Removal and Installation

a. REMOVAL. (1) Unscrew the two front magazine slide anchor nuts (fig. 57) and move magazine slide to rear as far as it will go.

(2) Remove the locking plate and unscrew the two trunnion block and mounting bracket screws on each side of the gun (fig. 57). Remove the two trunnion blocks.

(3) Slide the cradle forward until the magazine slide anchor bracket clears the magazine slide anchor. Slide the cradle to the rear and remove it from the gun.

(4) Remove the locking wire and unscrew the two anchor support bracket screws to disconnect the anchor support bracket (fig. 58).

Note. Further disassembly of the cradle is prohibited.

b. INSTALLATION. (1) Slide the cradle from the rear onto the gun as far as it will go, making certain the rollers on the cradle engage the cradle mounting plate.

(2) Slide the cradle slightly rearward so that magazine slide anchor will fit into recess in anchor support bracket. Replace the two anchor front nuts.

(3) Replace the two trunnion blocks so that they engage the trunnion on adapter, and so that lugs on blocks fit into slots in the mount-

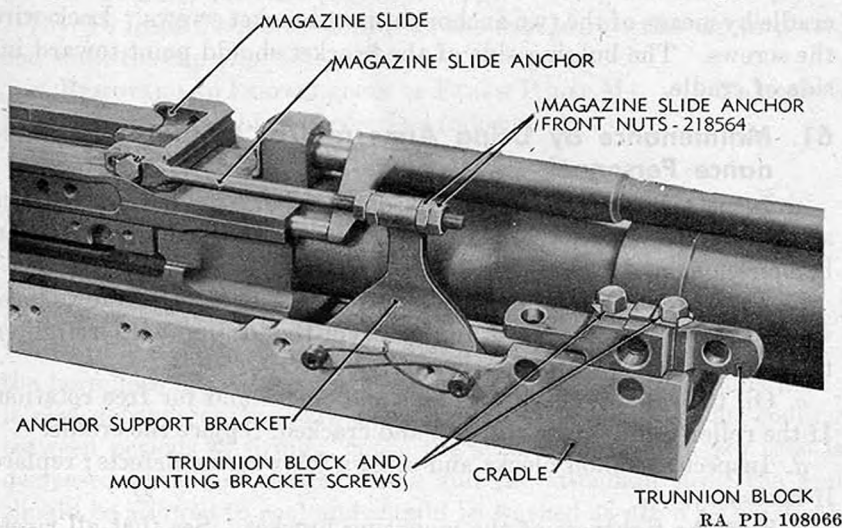
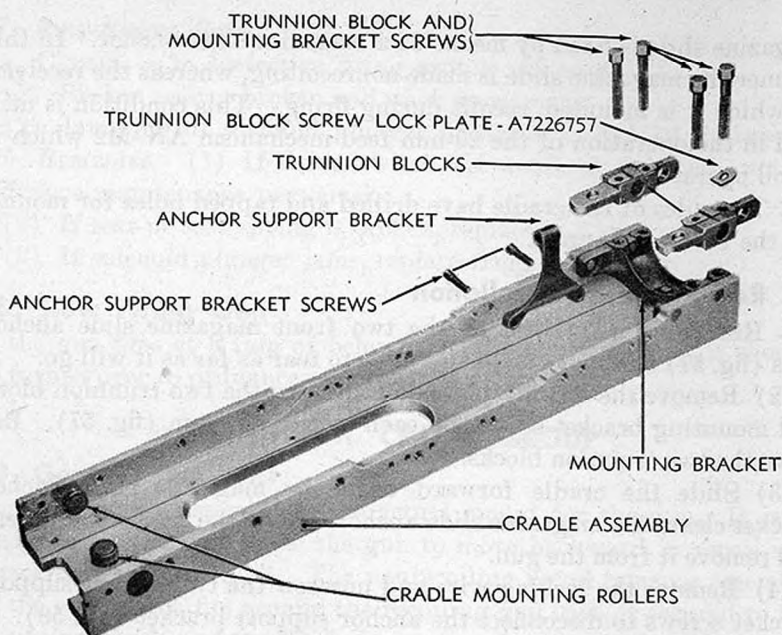

Figure 57. Removal of cradle.



RA PD 108067

Figure 58. Parts of cradle.

ing bracket. Slotted vertical flange of block should point toward muzzle (old type blocks have one flange; new type blocks have a flange at each end).

(4) Replace the locking plates, screw in the trunnion block and mounting bracket screws, and then secure the screws by bending up the corners of the plates.

(5) Secure the anchor support bracket to the inside wall of the cradle by means of the two anchor support bracket screws. Lock-wire the screws. The bulging side of the bracket should point toward inside of cradle.

61. Maintenance by Using Arms and/or Ordnance Maintenance Personnel

a. Inspect the cradle carefully for damaged or loose parts. If parts are allowed to work loose, the mounting holes in the cradle will soon become elongated and render the cradle unserviceable.

b. Test the anchor support bracket to see whether the screws have worked loose. If the screws are loose, cut the locking wire, retighten the screws, and secure with new wire.

c. Oil the rollers; check for chips and cracks and for free rotation. If the rollers bind or are chipped and cracked, replace the cradle.

d. Inspect trunnion blocks and screws for wear or defects; replace if necessary.

e. Test the tightness of the mounting bracket. See that all rivets

are tight. Check by tapping bracket a light blow on either end with a hammer. If bracket is loose, replace the cradle.

f. Chase out the threads in bracket if necessary (par. 42a(4)) (ordnance maintenance personnel only).

Section XVIII. TUBE AND RECEIVER GROUP

62. General

For the purposes of description, disassembly, and assembly, the following components are treated as parts of the tube and receiver group:

- a. Gun tube.
- b. Receiver.
- c. Rear buffer and driving spring guide.
- d. Magazine slide.

63. Gun Tube

a. GENERAL. (1) The tube serves to accommodate the front mounting arrangements, recoil housing, and the gas cylinder sleeve group (fig. 59).

(2) The threaded muzzle end is for attaching the flash hider (fig. 59). The threads to the rear of the threaded muzzle end (fig. 59) serve for attaching certain types of British mounts but are not used for mounting the gun in U. S. airplanes. When these threads are not in use, they are protected by a thread protector sleeve and cap (fig. 60).

b. REMOVAL AND INSTALLATION OF THREAD PROTECTOR SLEEVE AND CAP. (1) Unstake the thread protector cap (fig. 60).

(2) Unscrew the thread protector cap and slide the thread protector sleeve off the gun tube (fig. 60).

(3) To install, slide the sleeve on the tube, screw the cap in place, and stake the cap (fig. 60).

c. REMOVAL AND INSTALLATION OF FLASH HIDER M4. (1) To remove flash hider, if assembled, proceed as follows:

(a) Unscrew flash hider (fig. 61).

(b) Unscrew the flash hider nut.

(2) To install flash hider M4, proceed as follows:

(a) Screw the flash hider nut on the tube.

(b) Screw the flash hider on the tube (fig. 61).

d. MAINTENANCE BY USING ARMS. (1) Gun tubes become copper fouled to less extent when cared for in the proper manner. Wear in the bore does not depend entirely upon the number of rounds fired; it also depends on the care given the bore in cleaning and cooling between periods of firing. Since the accuracy life of a gun tube is decreased by a fast rate of firing and the attendant heat, the gun should be allowed to cool and should be washed as often as practical.

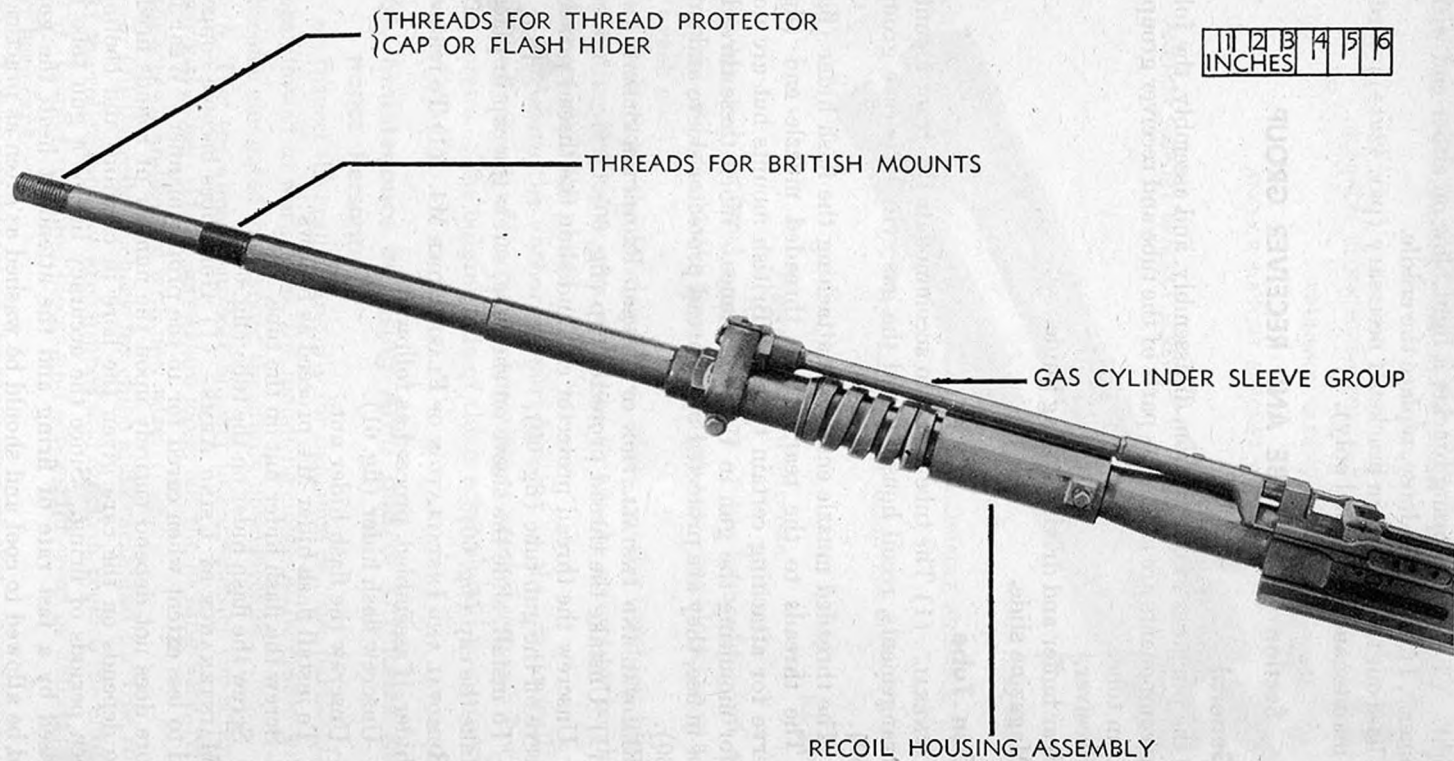
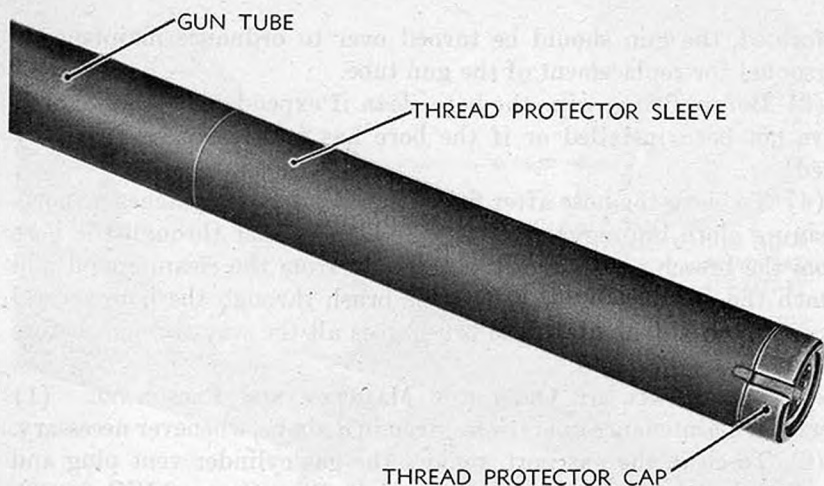
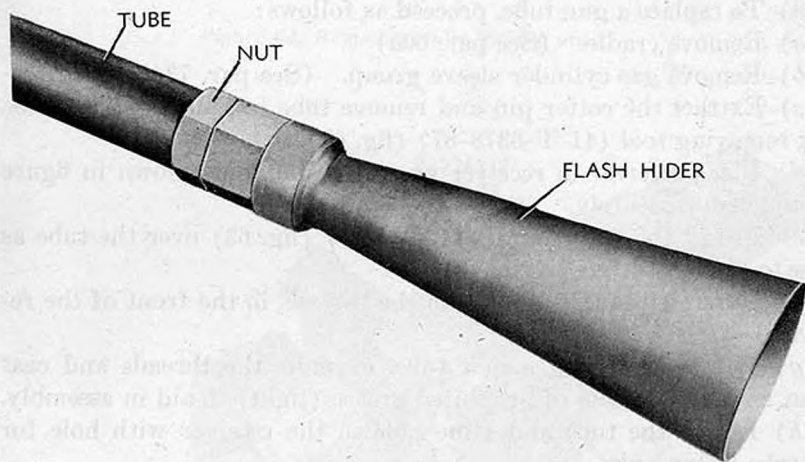

Figure 59. Gun tube showing components mounted on tube—Close-up view.



RA PD 93964

Figure 60. Thread protector cap and sleeve installed on gun tube.



RA PD 108044

Figure 61. 20-mm flash hider M4 installed on gun tube.

It is important that the gunner inspect the bore, whenever possible, to make certain that it does not contain extraneous particles that might cause damage to the gun.

(2) Note general appearance of gun bore for wear and deformation of lands and grooves and for pitting and pastilles. Examine for evidence of powder fouling and rust. Do not confuse coppering of bore with powder fouling. Present regulations prohibit the removal of copper fouling. A clean bore is not necessarily a shiny bore and may frequently have a dull gray appearance. A shiny, polished bore might indicate that abrasives have been used in cleaning operations. If the lands and grooves are excessively pitted or

deformed, the gun should be turned over to ordnance maintenance personnel for replacement of the gun tube.

(3) Before firing, wipe the bore clean if expendable muzzle covers have not been installed or if the bore has previously been heavily oiled.

(4) To clean the bore after firing, run several wet patches of bore-cleaning cloth impregnated with rifle-bore cleaner through the bore from the breech end. Remove the patch from the cleaning rod and attach the cleaning brush. Run the brush through the bore several times. Make certain that the brush goes all the way through before reversing the direction.

e. MAINTENANCE BY ORDNANCE MAINTENANCE PERSONNEL. (1) Perform maintenance operations given in *d* above, whenever necessary.

(2) To clean the gas port, remove the gas cylinder vent plug and bracket plug and clean with #16 American Wire Gage (AWG-0.0508-inch diameter). Make certain that no bits of the wire are left in gas port.

(3) To replace a gun tube, proceed as follows:

(a) Remove cradle. (See par. 60*a*)

(b) Remove gas cylinder sleeve group. (See par. 73*a*)

(c) Extract the cotter pin and remove tube locking pin with tube lock removing tool (41-T-3378-87) (fig. 62).

(d) Place receiver in receiver vise (41-V-405) as shown in figure 63, and clamp securely.

(e) Install the tube clamp (41-C-2005) (fig. 63) over the tube as close to the receiver as possible.

(f) Unscrew the tube and clean the threads in the front of the receiver.

(g) Before installing a new tube, examine the threads and coat them with a light film of graphited grease (light) to aid in assembly.

(h) Install the tube and aline hole in the receiver with hole for the tube locking pin.

(i) Ream a hole in tube to 25/64 inch.

(j) Install the tube locking pin and secure with a cotter pin.

64. Receiver

a. GENERAL (Figs. 64 and 65). (1) The receiver houses most of the working parts.

(2) The front of the receiver is threaded internally to receive the tube.

(3) A guideway on each side of the opening on top of the receiver accomodates the magazine slide by means of which the feed mechanism is secured to the gun.

(4) The rear of the receiver has vertical dovetail grooves for attaching the rear buffer.

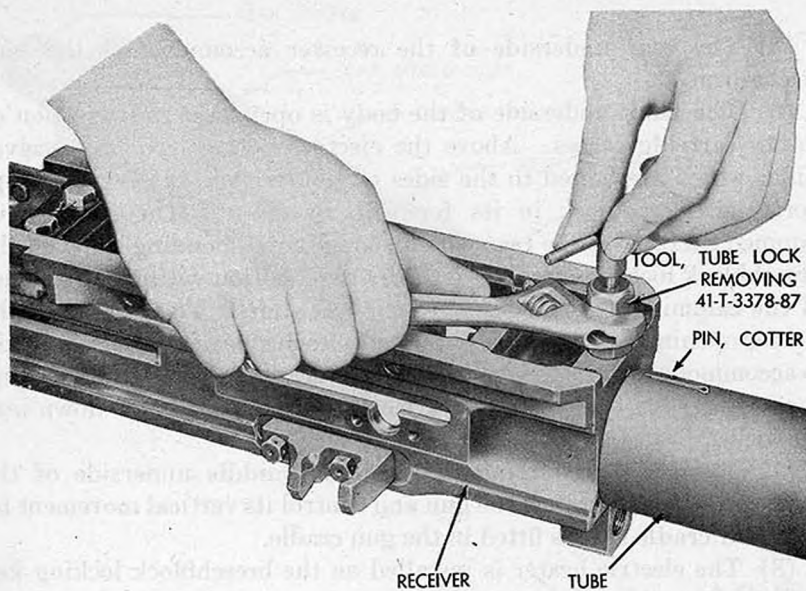

RA PD 91055

Figure 62. Removing tube locking pin.

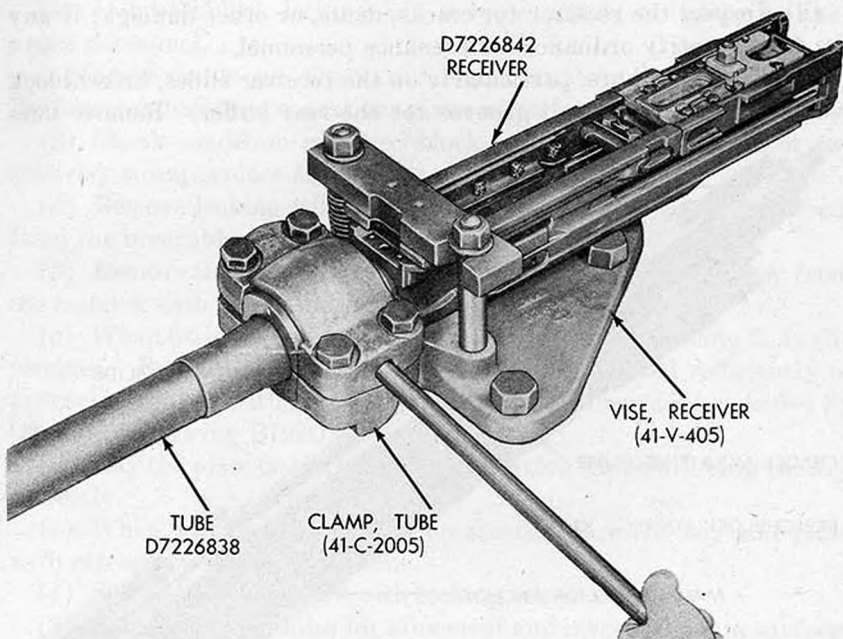

RA PD 91042

Figure 63. Replacing tube.

(5) The rear underside of the receiver accommodates the sear mechanism.

(6) The front underside of the body is open to permit ejection of empty cartridge cases. Above the ejector opening are two receiver slides which are bolted to the sides of the receiver and serve to support the breechblock in its forward movement. The slides have cammed surfaces at the rear which engage corresponding cams on the breechblock lock, to cam it into the locked position with the assistance of the camming action of the breechblock slides. To the rear of the ejector opening, a transverse slot is cut in each side of the receiver body to accommodate the breechblock locking key. The breechblock locking key engages the breechblock lock when the lock is cammed down into the locked position.

(7) The cradle mounting plate on the middle underside of the receiver serves to support the gun and control its vertical movement by means of cradle rollers fitted in the gun cradle.

(8) The electric heater is installed on the breechblock locking key and receiver slides.

b. MAINTENANCE BY USING ARMS. (1) Clean the receiver, particularly the portion near the tube, with rifle-bore cleaner to remove all primer salts. Wipe with a cloth dampened with oil.

(2) Inspect the receiver for cracks, dents, or other damage; if any are found, notify ordnance maintenance personnel.

(3) Check for burrs, particularly on the receiver slides, breechblock locking key, and dovetail grooves for the rear buffer. Remove burrs

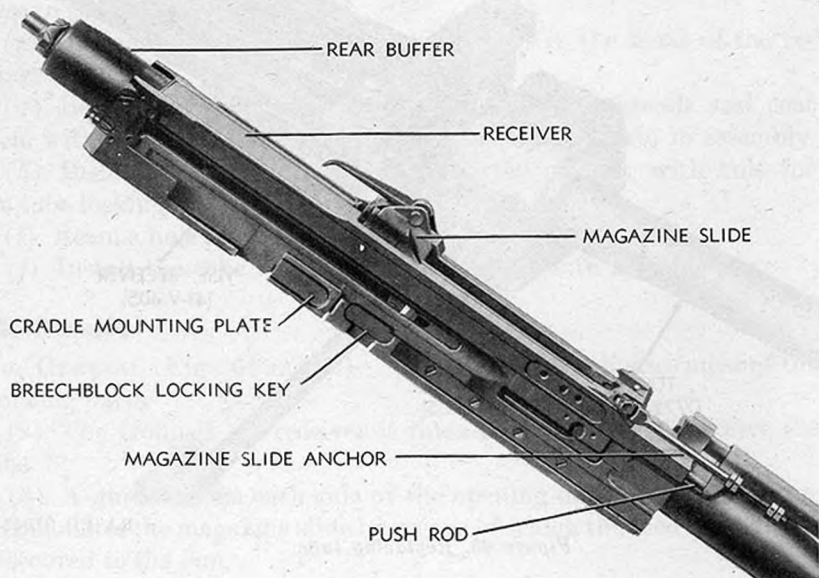

RA PD 93994

Figure 64. Receiver—Top right view.

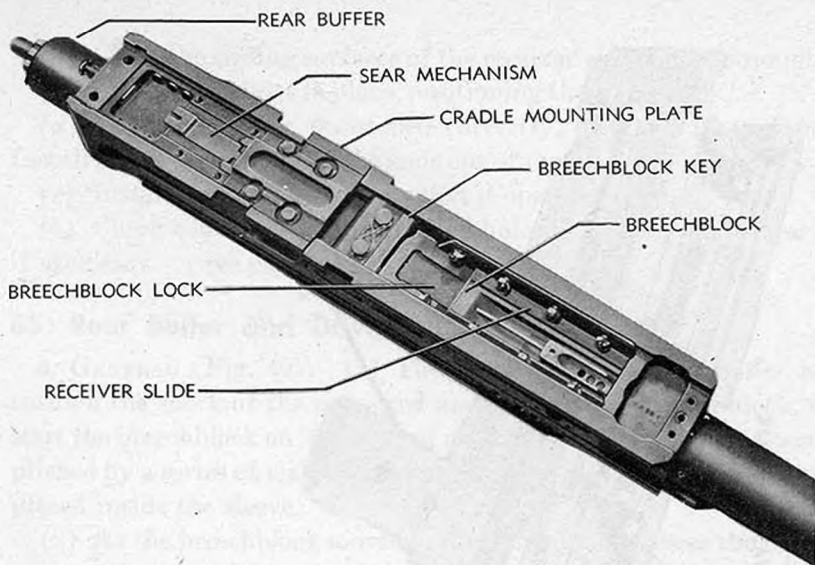

RA PD 93993

Figure 65. Receiver—Bottom view.

with crocus cloth or a fine oilstone. Do not remove more metal than is necessary.

(4) If breechblock locking key is loose, notify ordnance maintenance personnel.

c. MAINTENANCE BY ORDNANCE MAINTENANCE PERSONNEL. (1) Perform maintenance operations given in *b* above, whenever necessary.

(2) Check condition of breechblock locking key. If loose or excessively worn, replace as follows:

(a) Remove locking wire, the two cap screws, and the lock washers from the breechblock locking key.

(b) Remove the locking key plate and tap the breechblock key from the receiver with a brass drift and a hammer (fig. 66).

(c) When fitting a new key in place, make sure it is a snug fit in the receiver. Replace the receiver if key slot is elongated sufficiently to prevent a tight fit with a new key which meets dimensions specified by Ordnance Drawing B7226047.

(d) Lay the plate on the key as an indication for positioning the key correctly.

(e) When proper alignment is obtained, secure the key and plate with cap screws and lock washers.

(f) Secure the cap screws with locking wire.

(3) Check receiver slides for alignment and inspect the cam surfaces for damage. If slides are misaligned or cam surfaces damaged, replace the slides as follows:

(a) Extract the cotter pins and remove the castle nuts, lock washers, and bolts to release the slides.

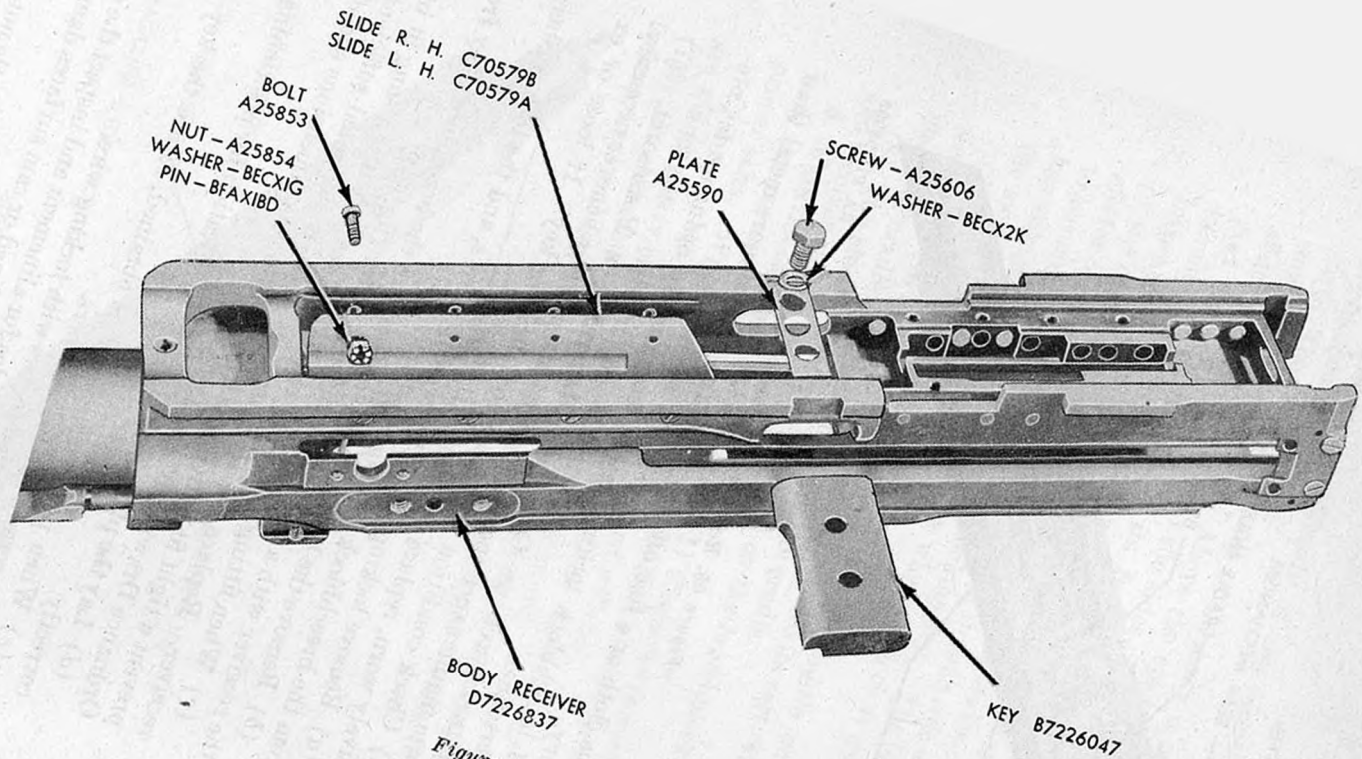

Figure 66. Parts of receiver.

- (b) Clean the sliding surfaces of the receiver and slides thoroughly.
- (c) Install new slides in place, positioning them carefully.
- (d) When slides are positioned correctly, install bolts and nuts. Install cotter pins and bend the ends out of the way.
- (e) Install breechblock and see that it operates freely.
- (4) Check condition of all threaded holes in receiver and chase out if necessary. (See par. 42a (4).)

65. Rear Buffer and Driving Spring Guide

a. GENERAL (Fig. 49). (1) The function of the rear buffer is to cushion the shock of the rearward movement of the breechblock, and start the breechblock on its forward movement. This action is accomplished by a series of ring springs guided by a sleeve, and a coil spring placed inside the sleeve.

(2) As the breechblock moves to the rear, it compresses the driving spring; this absorbs much of the inertia of the breechblock. As the breechblock hits the rear buffer, it transmits the shock of recoil to the springs. The springs absorb the remaining shock and bring the breechblock to a stop. At this time, the rear buffer springs and the driving spring expand, forcing the breechblock forward.

b. REMOVAL. (1) With a blunt chisel, straighten the rim of the driving spring guide retainer so that it does not engage the driving spring guide head (fig. 67). Similarly, disengage driving spring guide cap lock plate from cap (if used), unscrew cap, and remove plate (fig. 68).

(2) Insert the driving spring assembling tool through the driving spring guide head. Push the tool forward until it engages the driving spring guide plunger (fig. 69).



Figure 67. Straightening driving spring guide retainer.

RA PD 93996

DRIVING SPRING GUIDE CAP

DRIVING SPRING GUIDE
CAP LOCK PLATE - A7230778

RA PD 108072

Figure 68. Removal of driving spring guide cap and cap lock plate.

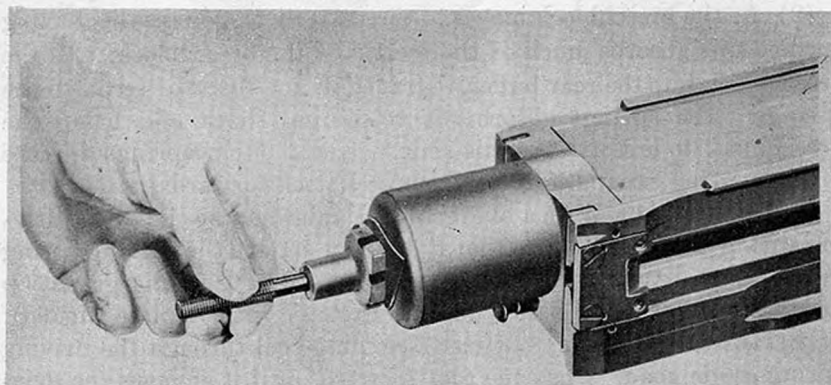

RA PD 93997

Figure 69. Inserting driving spring guide assembling tool.

(3) Unscrew the driving spring guide sleeve assembly, using the special rear buffer wrench. Remove the guide with the driving spring and plunger (fig. 70).

(4) Retract the rear buffer lock plunger and remove the rear buffer group by sliding it out of the dovetail grooves in the receiver (fig. 71).

(5) Keep the driving spring guide retainer with the rear buffer.

Note. Disassembly of rear buffer is prohibited.

c. INSTALLATION. (1) Slide the rear buffer up in the dovetail grooves of the receiver.

2. Retract the rear buffer lock plunger and slide the buffer upward until the plunger snaps into position in the slot in the receiver.

(3) Position the driving spring retainer (old type) on the rear buffer so that pin on the retainer fits into hole on rear buffer. New

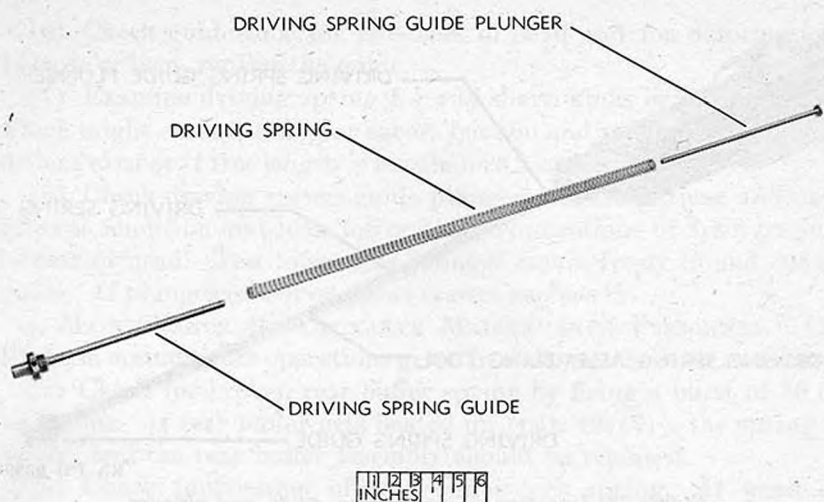

Figure 70. Driving spring guide and plunger.

RA PD 94019

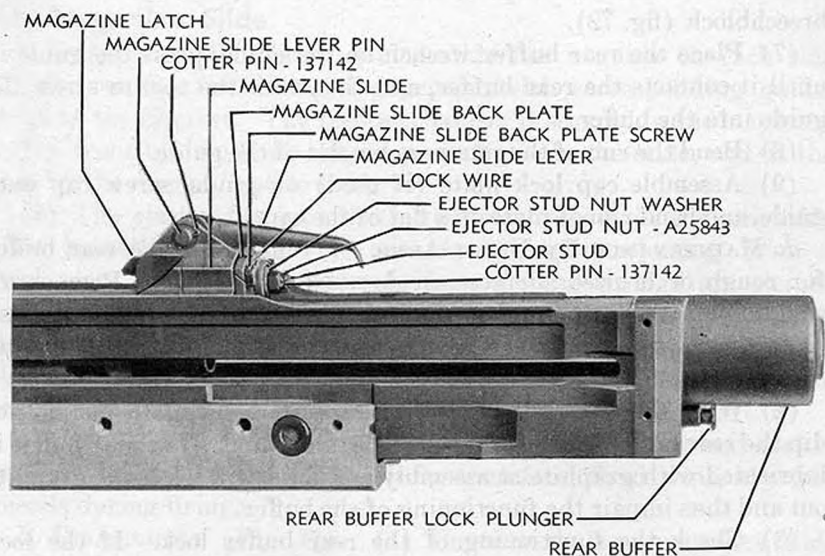

Figure 71. Removal of rear buffer and magazine slide.

RA PD 108053

type retainer does not have a pin but has a flange which fits under rear buffer.

(4) Insert the split end of the driving spring assembling tool into the driving spring guide plunger.

(5) Place the driving spring over the tool and plunger. Insert the driving spring guide into the driving spring so that it fits over the tool.

(6) Insert the assembled unit into the receiver through the opening

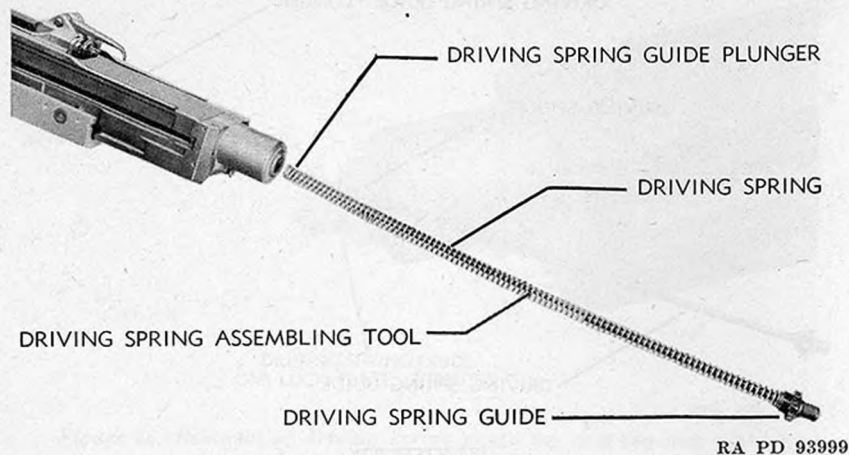

RA PD 93999

Figure 72. Inserting driving spring, guide, and plunger.

of the rear buffer, making certain that it slides into the bore of the breechblock (fig. 72).

(7) Place the rear buffer wrench on the guide, press the guide in until it contacts the rear buffer, and then turn the tool to screw the guide into the buffer.

(8) Bend the rim of the retainer on a flat of the guide.

(9) Assemble cap lock plate (if used) on guide, screw cap onto guide, and bend rim of plate on a flat of the cap.

d. MAINTENANCE BY USING ARMS. (1) Examine the rear buffer for rough or bruised surfaces on dovetail connections. Remove all rough spots with crocus cloth or fine oilstone to make a good push fit to the receiver. If fit is too tight, it will tend to spread the receiver; if too loose, it will cause the buffer to hammer the receiver.

(2) Wipe the dovetail surfaces clean with a dry cloth but do not dip the rear buffer in any prescribed cleaning fluid. The rear buffer is lubricated with graphite at assembly and fluid will wash the graphite out and thus impair the functioning of the buffer.

(3) Check the functioning of the rear buffer lock. If the lock malfunctions or if the buffer is otherwise damaged, replace the rear buffer. Remove all burrs from lock plunger but take off no more metal than is absolutely necessary; removal of excess metal will cause the plunger to fit loosely and allow the rear buffer to move vertically in the receiver.

(4) Examine retainer assembly for condition; note whether pin on face of retainer is broken, bent, or missing. If any of these conditions exist, replace the retainer.

(5) Note condition of threads on driving spring guide; if mutilated or excessively worn, replace guide.

(6) Check guide tube for looseness in head and for deformation. If loose or bent, replace the guide.

(7) Examine driving spring for any sharp kinks or offset of coils which might cause binding or excess friction and replace if these conditions exist or if free length is less than 23.5 inches.

(8) Check driving spring guide plunger for straightness and note general condition and look for cracks or indications of fracture just in rear of head. Test to see that plunger moves freely in and out of guide. If plunger is bent or shows cracks, replace it.

e. MAINTENANCE BY ORDNANCE MAINTENANCE PERSONNEL. (1) Perform maintenance operations given in *d* above, whenever necessary.

(2) Check for broken rear buffer spring by firing a burst of 10 or 15 rounds. If rear buffer gets heated up (par. 42*c*(3)), the spring is broken and the rear buffer assembly should be replaced.

(3) Check functioning of rear buffer lock spring. If weak or broken, drive out lock plunger pin, remove lock collar, plunger and spring, replace spring, and assemble.

66. Magazine Slide

a. GENERAL. (1) The magazine slide has a guide on each side which provides for sliding engagement with corresponding guideways on the receiver. The feed mechanism is secured to the magazine at the front by two hook-shaped projections on the slide, and at the rear by the magazine slide latch.

(2) The ejector fits into the lower two grooves in the magazine slide beneath the latch. It has two prongs projecting from a steel plate. The upper inner surfaces of the prongs are shaped to enter the incoming round into the path of the breechblock as it moves forward. The top shoulder of the breechblock moves between the two prongs of the ejector. The prongs deflect the empty cartridge case downward as the breechblock moves to the rear.

(3) The slide is connected by the magazine slide anchor and anchor support bracket to the cradle; it is, therefore, fixed while the gun recoils during firing.

b. DISASSEMBLY (Fig. 11). (1) Unscrew the two magazine slide anchor front nuts.

(2) Remove the rear buffer. (See par. 65*b*.)

(3) Remove the cotter pin from the ejector stud.

(4) Unscrew the ejector stud nut.

(5) Withdraw the ejector, taking care not to lose the two ejector springs.

(6) Remove the ejector stud nut washer (steel) and ejector stud washer (fiber).

(7) Remove the lock wire and unscrew the magazine slide back-plate screws, keeping the screws even.

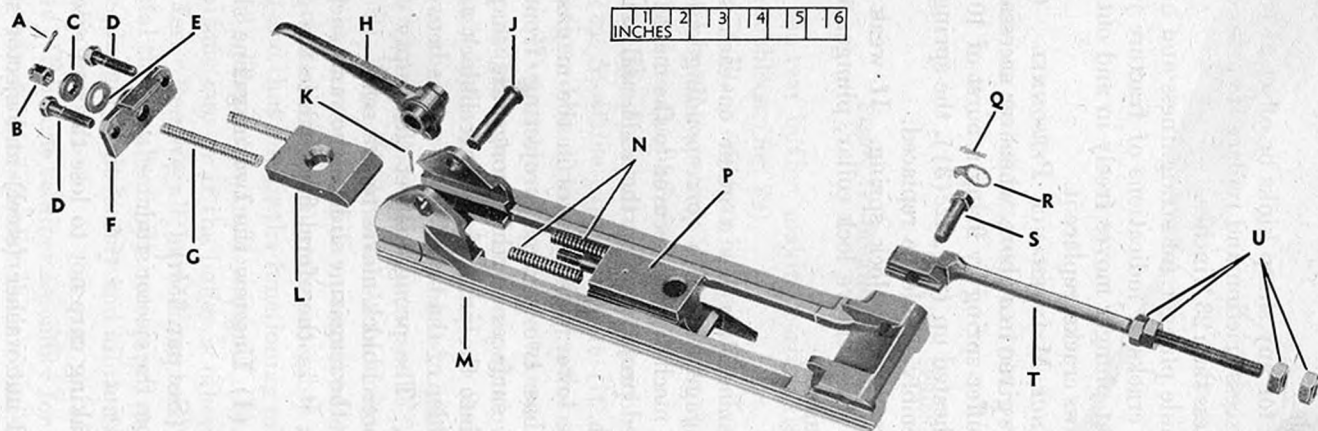

- A—COTTER PIN - 137142
 B—EJECTOR STUD NUT - A25843
 C—EJECTOR STUD NUT WASHER (STEEL)
 D—MAGAZINE SLIDE LOCK PLATE SCREWS
 E—EJECTOR STUD WASHER (FIBRE)
 F—MAGAZINE SLIDE BACK PLATE
 G—MAGAZINE LATCH SPRINGS
 H—MAGAZINE SLIDE LEVER
 J—MAGAZINE SLIDE LEVER PIN
 K—COTTER PIN - 137142

- L—MAGAZINE LATCH
 M—MAGAZINE SLIDE
 N—EJECTOR SPRINGS - A25846
 P—EJECTOR - B7229942
 Q—COTTER PIN - 137142
 R—ANCHOR SCREW LOCK WASHER - A25613
 S—ANCHOR SECURING SCREW - A25607
 T—MAGAZINE SLIDE ANCHOR
 U—MAGAZINE SLIDE ANCHOR NUTS - 218564

Figure 73. Magazine slide parts.

- (8) Remove the backplate and the two latch springs.
- (9) Remove the cotter pin from the magazine slide lever pin and remove the lever pin, lever, and latch.
- (10) Slide the magazine slide to the rear and off the receiver.
- (11) Remove the cotter pin from the anchor securing screw.
- (12) Remove the anchor screw lock washer.
- (13) Unscrew the anchor securing screw and withdraw the magazine slide anchor from the magazine slide.
- (14) Magazine slide parts are shown in figure 73.

c. ASSEMBLY (FIG. 65). (1) Fit the magazine slide anchor to the magazine slide. The threaded end of the anchor should point away from front end of slide (fig. 73). The anchor should be on same side with anchor support bracket. (See par. 12.)

(2) Screw in the anchor securing screw, replace the anchor screw lock washer, and secure with the cotter pin.

(3) Slide the magazine slide (anchor leading) on the gun.

(4) Place the magazine latch on the upper grooves in the rear of the magazine slide. The sharp end of the latch should point toward the muzzle of gun so that the angle surface on the latch can be seen when looking down (fig. 74).

(5) Position the magazine slide lever on the magazine latch. The ball on the lever should fit into the hole of the latch, the lever handle should point to the rear, and the holes in the magazine slide should align with the hole in the lever. Push in the lever pin and secure with the cotter pin (fig. 74).

(6) Insert the two latch springs into their seats in the rear of the latch.

(7) Place the magazine slide backplate flush against the latch springs and screw in the two magazine slide backplate screws. The screws should be screwed in evenly. Lock-wire the screws.

(8) Insert the two ejector springs into their seats in the rear of the ejector. Position the ejector in the two grooves of magazine slide below the latch and slide it to the rear until the ejector stud protrudes through the hole in the backplate.

(9) Place the fiber ejector stud washer on the ejector stud, follow with the steel ejector stud nut washer, and then screw on the ejector stud nut. Secure the nut to the stud with a cotter pin.

(10) Replace the anchor front nuts.

d. MAINTENANCE BY USING ARMS. (1) Check movement of magazine slide on receiver. Remove any burrs from guideways on slide. If magazine moves with excessive sideplay, replace the slide.

(2) Check functioning of magazine latch springs. If springs are weak, check free length and replace if necessary. (See par. 38*h*.)

(3) Check free length of ejector springs and replace if necessary. (See par. 38*h*.)

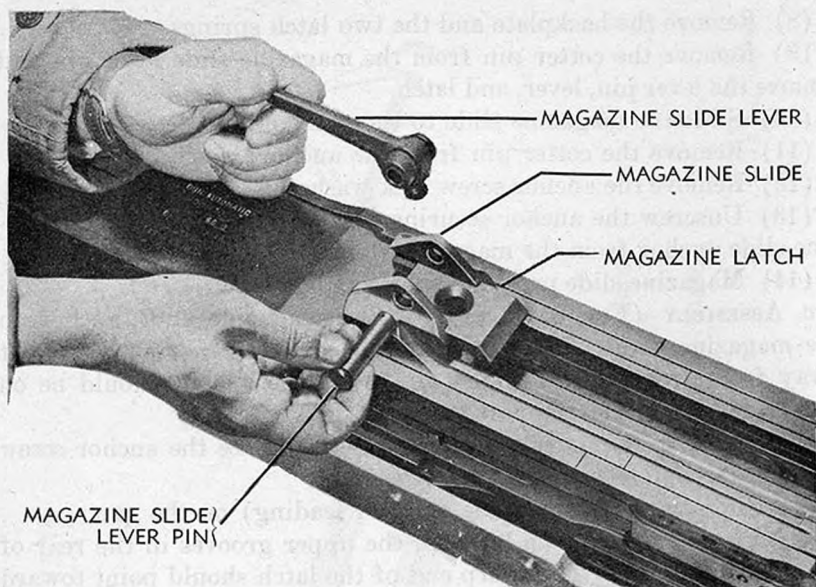

RA PD 94004

Figure 74. Assembly of magazine slide.

(4) Check movement of magazine latch in grooves of slide; it must slide freely. Remove any burrs from the angle surface of the magazine latch and from the ejector.

(5) If the ejector horns or the ejector stud show signs of fracture, replace the ejector.

(6) Inspect the ejector for wear on the slides and on the two prongs. Use a smooth stone to remove burrs from the prongs. The ejector must slide freely in the grooves of the magazine slide, but should have a minimum amount of side play. Replace ejector if stud is loose or threads damaged.

(7) Replace the fiber washer on the ejector stud, if it is deformed.

e. MAINTENANCE BY ORDNANCE MAINTENANCE PERSONNEL. (1) Perform maintenance operations given in *d* above, whenever necessary.

(2) Chase out threaded holes in magazine slide whenever necessary. (See par. 42a (4).)

(3) If ejector stud is damaged or loose, drive out the ejector stud pin, unscrew the ejector, and examine condition of threads in ejector. Chase out if necessary, replace ejector, and pin securely.

Section XIX. BREECHBLOCK GROUP

67. General

The function of the breechblock group is to carry the round from the mouth of the feed mechanism into the chamber, fire the round, extract

and eject the empty case, and support the case until it is deflected out of the receiver by the ejector. For detailed description of functioning, see section XV.

68. Removal and Installation

a. **REMOVAL OF BREECHBLOCK.** (1) Remove the rear buffer. (See par. 65b.)

(2) Back up the two magazine slide anchor rear nuts all the way (fig. 75) and move the magazine slide forward as far as it will go (fig. 75).

(3) Place the breechblock unlocking tool on right side of breechblock in receiver and manipulate the tool so that the projection on the arm of the tool engages the front face of the right breechblock slide, and the other arm of the tool is along the top of the breechblock with its end against the receiver (fig. 75).

(4) Press the lever of the tool forward (fig. 76) until the breechblock is unlocked (fig. 77).

(5) Move the breechblock to the rear of the receiver. As soon as it starts to come out, grasp the breechblock lock and hold it in the unlocked position (fig. 78). Failure to do this may cause the breechblock to get jammed in the rear portion of the receiver as it is being pulled out. Pull the breechblock out of the receiver. Do not drop the breechblock lock.

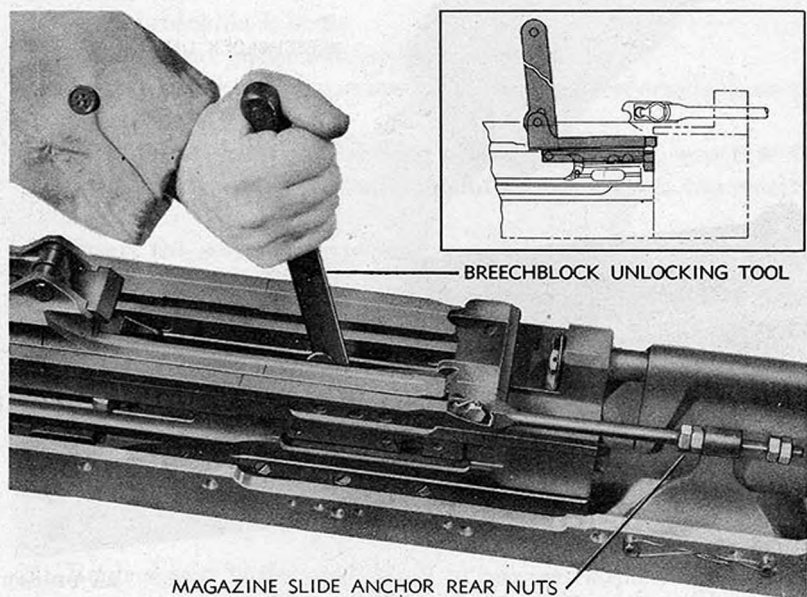

RA PD 94009

Figure 75. Positioning breechblock unlocking tool in gun.

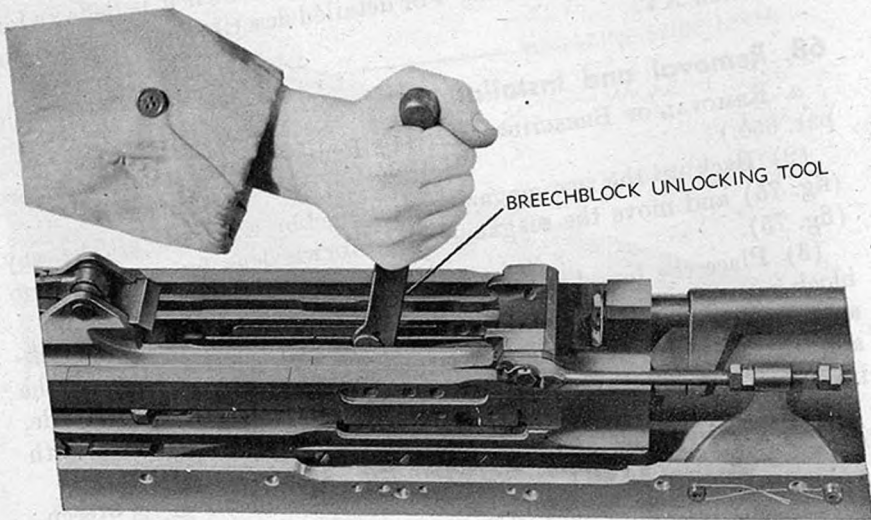

RA PD 94010

Figure 76. Unlocking breechblock.

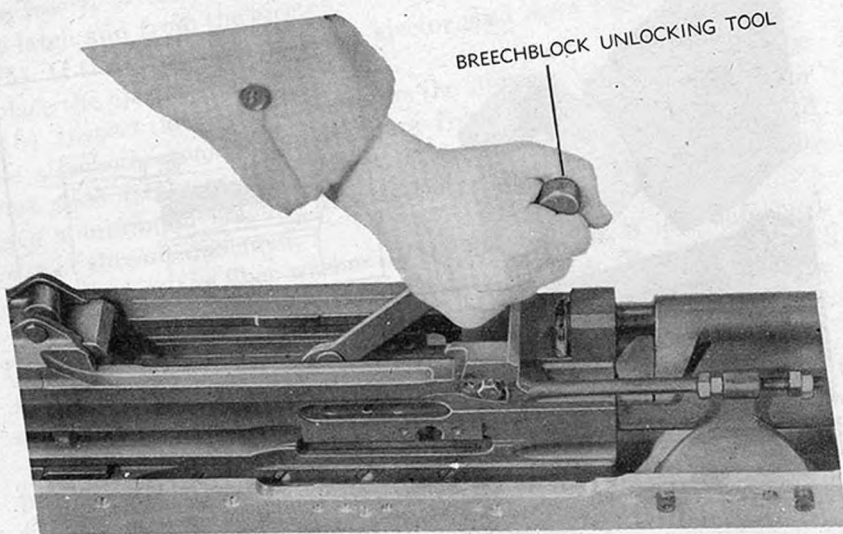

RA PD 94011

Figure 77. Breechblock unlocked.

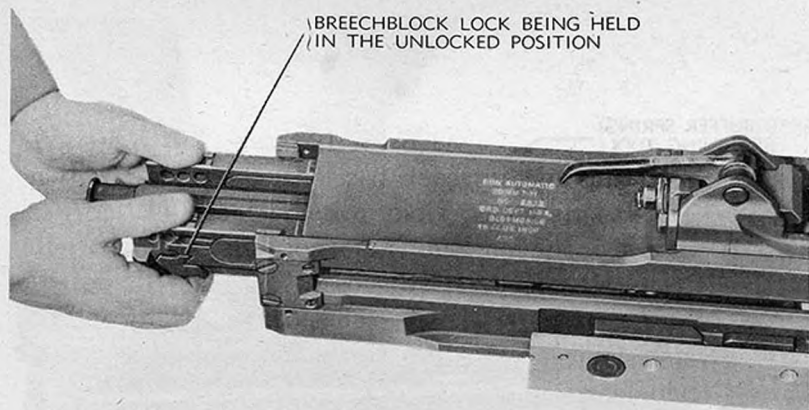

RA PD 94012

Figure 78. Removing breechblock from receiver.

Note. If the special tool is not available, force the gas cylinder push rods rearward to unlock the breechblock or actuate with charger.

b. INSTALLATION OF BREECHBLOCK. (1) Assemble the breechblock lock to the breechblock by forcing the breechblock slides rearward and, at the same time, exerting pressure against the lock until it is in the unlocked position.

(2) Hold the breechblock firmly in this position and push it into the receiver as far as it will go so that the lock will not spring out of position (fig. 78).

(3) Push breechblock home.

(4) Replace rear buffer and adjust magazine slide.

c. REMOVAL OF SEAR MECHANISM. (1) Remove the cradle from the gun. (See par. 60a.)

(2) Straighten the two mounting screw lock plates, unscrew the four screws, and remove the cradle mounting plate from the receiver (fig. 213).

(3) Insert the sear buffer retaining tool into the hole in the sear block. Push the tool through the sear block so that it fully engages the circumferential grooves on the sear buffer spring plungers (fig. 79).

(4) Carefully lift the sear block and sear out of the receiver with the retaining tool in place (fig. 79). Remove the steel and fiber sear buffer blocks from the receiver.

d. INSTALLATION OF SEAR MECHANISM. (1) Replace the sear with sear block in receiver. Do not remove sear buffer spring retaining tool.

(2) Replace sear buffer steel block in receiver adjacent to the sear block.

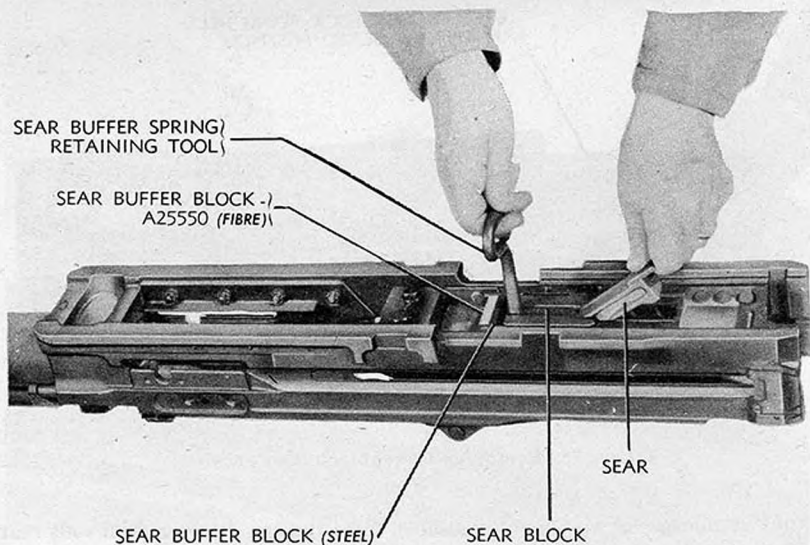

RA PD 108035

Figure 79. Removing sear and sear block from receiver.

(3) Replace the sear buffer fiber block in receiver next to steel block with flat side adjacent to steel block.

(4) Hold down the sear block and remove the sear spring retaining tool.

69. Disassembly and Assembly

a. DISASSEMBLY OF BREECHBLOCK. (1) Remove the breechblock lock. Remove the left and right inertia blocks (fig. 80).

(2) Withdraw the left breechblock slide, being careful not to let the breechblock slide spring and guide fly out (fig. 80). Then withdraw the breechblock slide plate assembly, taking care not to let the spring and guide fly out (fig. 80). Do not remove the breechblock slide key except for replacement.

(3) Press the extractor against the extractor spring and drift out the extractor pin. Withdraw the extractor and extractor spring (fig. 80). Lift the front end of the breechblock and allow the firing pin to slide out through the rear. Do not drop the firing pin.

b. ASSEMBLY OF BREECHBLOCK. (1) Insert the firing pin in bore of breechblock, slide it forward, and position it so that slot in firing pin aligns with the recess for the breechblock slide key.

(2) Install the extractor spring and extractor and secure with extractor pin.

(3) Install the right-hand breechblock slide assembly, making certain that the slide key engages the slot in the firing pin. Install the left-hand breechblock slide.

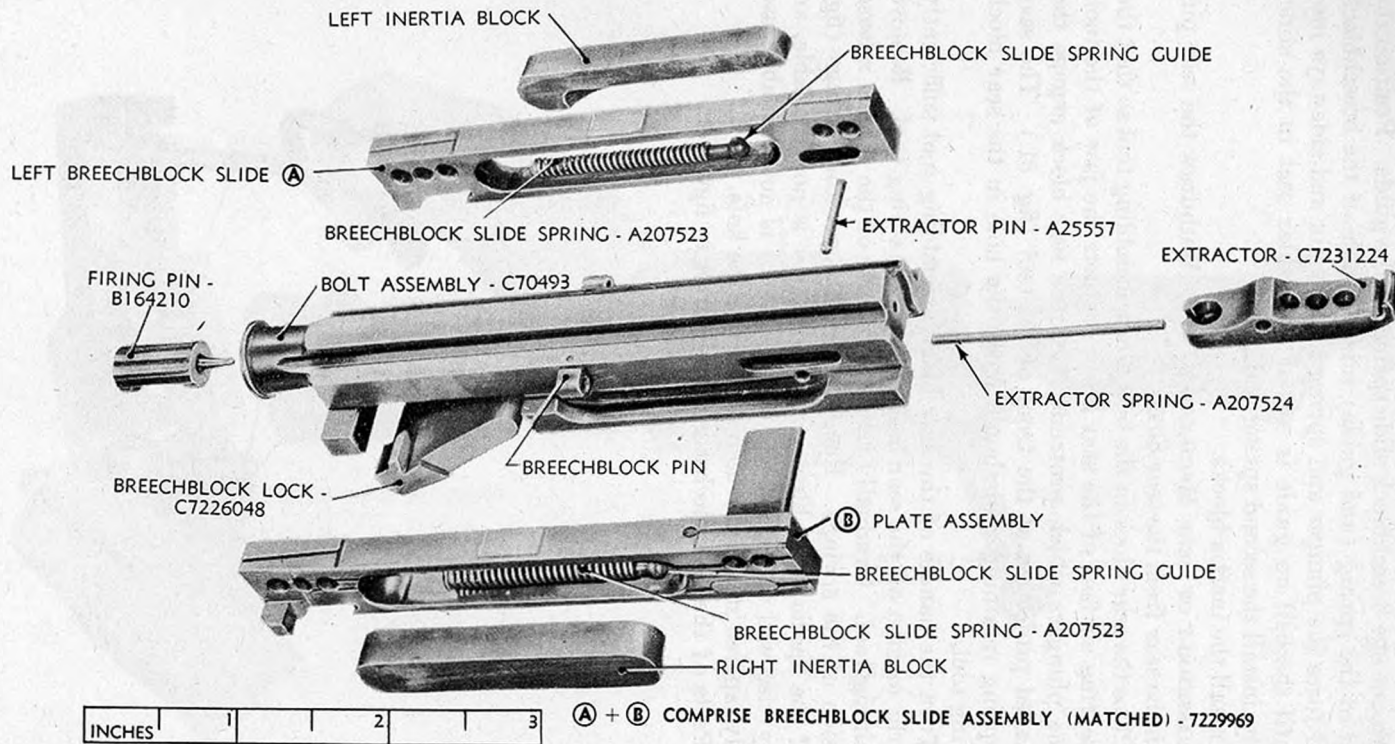

Figure 80. Breechblock parts.

RA PD 108074

(4) Mount one breechblock slide spring on the guide. Position the rear end of the spring (and guide) into the hole of the breechblock pin, and force the plunger and spring against pin and sideways into slide until the ball on guide is seated in circular seat in the slide. Similarly, install the second spring and guide.

(5) Install the inertia blocks.

c. **DISASSEMBLY OF SEAR MECHANISM.** (1) Withdraw the sear pin to detach the sear from the sear block.

(2) Place the sear block in the sear block assembling tool so that the radial bearing surface of the sear block contacts the jaw of the tool, while the plungers which protrude from the sear block engage the hook-shaped projection at the front of the tool (fig. 81.) The sear buffer spring retaining tool should enter the hole in the sear block assembling tool.

(3) Turn the handle of the sear block assembling tool sufficiently to take the tension off the sear buffer spring retaining tool. Remove the retaining tool. Gradually turn the handle of the tool to release the tension of the springs. Remove the plungers and springs (fig. 81). If the special sear block assembling tool is not available, an ordinary vise will serve. If the retaining tool is not available, use a slightly tapered steel rod which nearly fills the hole.

(4) Parts of the sear mechanism are shown in figure 82.

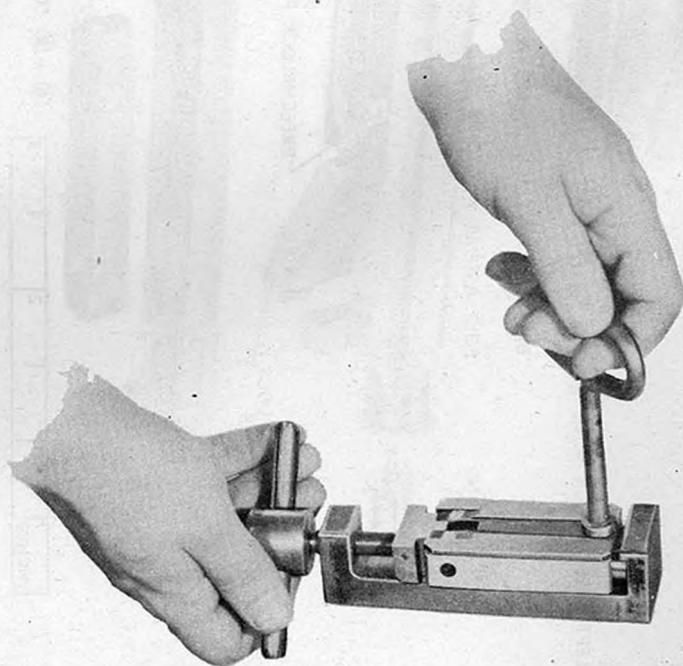

Figure 81. Disassembling sear block.

RA PD 10937

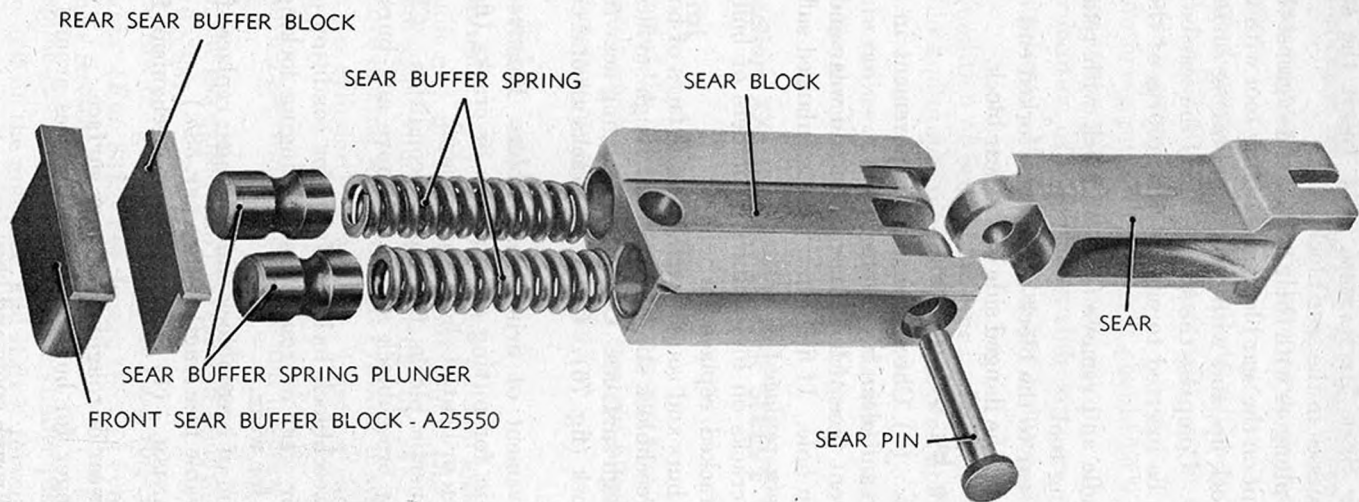

Figure 82. Parts of sear mechanism.

RA PD 110935

d. ASSEMBLY OF SEAR MECHANISM. (1) Insert the sear buffer springs in their recesses in the sear block.

(2) Replace the plungers with their hollow ends against the springs.

(3) Place the unit on the sear block assembling tool with the flanged side of the sear block up, and with the radial bearing surface against the jaw of the tool. Compress the springs until the sear buffer spring retaining tool can be inserted to engage the grooves of the plungers (fig. 81).

(4) Loosen handle and remove the sear block with retaining tool from the assembling tool.

(5) Attach the sear to the block so that the forked end of the sear is on the same side as the flanged side of the sear block.

70. Maintenance by Using Arms

a. BREECHBLOCK. (1) Check freedom of movement in receiver.

(2) Disassemble and clean breechblock.

(3) Examine front face of bolt for erosion and wear and note condition of firing pin hole. If firing pin hole is enlarged sufficiently to cause blown primers, replace the bolt.

(4) Check for cracks on longitudinal shoulders of bolt (fig. 80). If shoulders are cracked, replace the bolt.

(5) Remove all burrs and rough spots from surfaces of bolt.

(6) Examine breechblock slides for burrs or rough surfaces on cam; remove burrs or rough surfaces. Check for swedging near front end of slot for inertia block (fig. 76). Check for cracks around cam surface (fig. 80).

(7) Check movement of firing pin in bolt. Remove any burrs. Examine firing pin for pitting deformation or cracks (fig. 80). If firing pin is broken or bent, it should be replaced.

(8) Examine inertia blocks for general condition. Check movement of blocks in breechblock slides. Remove any burrs or rough spots.

(9) Examine breechblock lock carefully for condition of cams on both sides and for wear or roughness on hinging locking surfaces. Check under side for wear.

(10) Test tension of breechblock slide springs; replace if broken or shorter than allowable free length. (See par. 38*h*.)

b. SEAR MECHANISM. (1) Examine sear mechanism for general condition.

(2) Check for wear or roughness on sear surface.

(3) Check plunger for burrs or rough surfaces around the disassembling recesses.

(4) Remove all rough spots and burrs.

(5) Check tension of sear buffer springs; replace if broken or shorter than allowable free length. (See par. 38*h*.)

71. Maintenance by Ordnance Maintenance Personnel

a. Perform maintenance operations given in paragraph 70 whenever necessary.

b. Measure diameter of firing pin hole, which should be 0.156 inch +0.004. A No. 22 (0.157) standard drill can be used to clean the firing pin hole to proper size.

c. Measure firing pin protrusion; it should be 0.100 to 0.110 inch. If protrusion is less, discard firing pin.

d. Note condition of breechblock slide key; see whether taper pin is in place or loose. If taper pin in key is loose, replace with a new pin.

e. Note condition of breechblock pins. If loose or damaged, drive out breechblock pin taper pins and replace breechblock pins and taper pins.

f. Measure radius of sear at point indicated by arrow in figure 82. If radius is less than 0.04 inch, replace the sear.

Section XX. GAS CYLINDER SLEEVE GROUP

72. General

The function of the gas cylinder sleeve group is to unlock the breechblock so that it can be forced back by straight blowback action. For details of functioning, see paragraph 45.

73. Disassembly and Assembly

a. **DISASSEMBLY.** (1) Remove cotter pin and lock washer from gas cylinder guide and unscrew gas cylinder guide (fig. 83).

(2) Remove gas cylinder sleeve spring (fig. 83).

(3) Remove locking wire from gas cylinder bracket plug and then remove the gas cylinder lock washer. Unscrew gas cylinder bracket plug (fig. 83).

(4) Remove gas cylinder lock plate and unscrew gas cylinder vent plug (fig. 83).

(5) Push the gas cylinder to the rear and remove gas cylinder with the sleeve (fig. 83).

(6) Withdraw the gas cylinder sleeve push rods (fig. 83).

b. **ASSEMBLY (FIG. 83).** (1) Insert the gas cylinder sleeve push rods into their recesses in the receiver.

(2) Assemble gas cylinder to the gas cylinder piston on the sleeve, position the unit on the gun tube, and slide it forward so that the gas cylinder fits in the opening in gas cylinder bracket.

(3) Screw in the gas cylinder vent plug and replace the gas cylinder lock plate.

- A— GAS CYLINDER SLEEVE SPRING
- B— GAS CYLINDER SLEEVE AND PISTON
- C— GAS CYLINDER
- D— 041 LOCKING WIRE
- E— GAS CYLINDER LOCK WASHER
- F— GAS CYLINDER BRACKET PLUG - B163320
- G— GAS CYLINDER LOCK PLATE
- H— GAS CYLINDER VENT PLUG - B7229626
- J— GAS CYLINDER BRACKET
- K— GAS CYLINDER SLEEVE PUSH ROD
- L— GAS CYLINDER GUIDE
- M— GAS CYLINDER GUIDE LOCK WASHER
- N— COTTER PIN - 137142

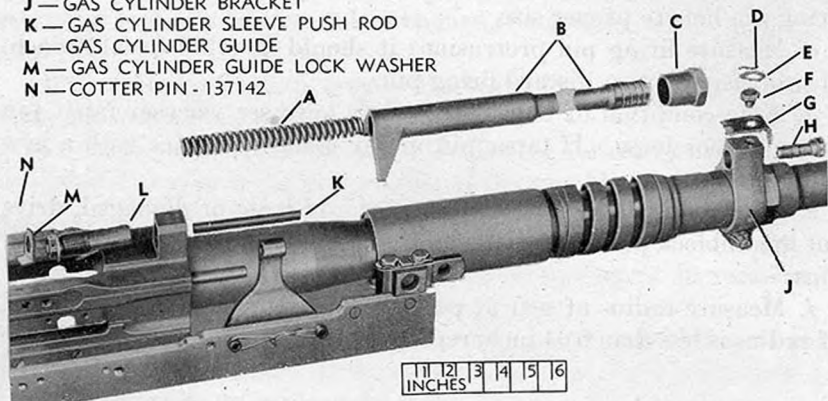

RA PD 108069

Figure 83. Parts of gas cylinder sleeve group.

(4) Screw in the gas cylinder bracket plug, replace the gas cylinder lock washer, and secure with locking wire.

(5) Replace the gas cylinder sleeve spring.

(6) Screw in the gas cylinder guide, replace lock washer, and secure with the cotter pin.

74. Maintenance by Using Arms

a. Examine all parts for condition. If sleeve is bent, replace it.

b. Check tension of gas cylinder sleeve spring; if kinked or shorter than allowable free length (par. 38h), replace it.

c. Check movement of gas cylinder sleeve guide in sleeve. Guide should have a medium close fit in sleeve. If clearance is excessive, replace with new parts.

d. Check gas cylinder vent plug for looseness; if loose, replace it. Whenever replacing the vent plug, use the new type of vent plug (larger vent hole) which can be identified by the part number B7229626 stamped on its face.

e. Remove all carbon and any other foreign matter from cylinder, piston, bracket, and plugs.

f. Remove burrs from piston if not burred excessively. If it is excessively burred, replace gas cylinder sleeve with piston.

g. Check movement of push rods in their recesses in receiver. Remove all burrs from push rods.

75. Maintenance by Ordnance Maintenance Personnel

a. Perform maintenance operations given in paragraph 74 whenever necessary.

b. Guns that were converted to the T31 (M3) included both long and short chamber tubes. To provide proper chamber length, approximately two threads of length were removed from the long chamber tube before installation in the weapon, which resulted in a misalignment between the tube gas port and the bracket gas port. This misalignment was originally compensated for by applying a 0.06×45 degree chamfer to the bracket gas port. This chamfer was found to be insufficient in all cases since occasionally a slow rate of fire was experienced. The deficiency was corrected in production in February 1945 by applying a 0.10×45 degree chamfer to the bracket gas port. The rate of fire of guns with the converted long chamber tube, if found to be slow as a result of incorrect port alignment, can be increased by removing the gas cylinder bracket (par. 77*a*) and applying a chamfer of 0.10×45 degrees.

Section XXI. RECOIL GROUP

76. General

The function of the recoil group is to absorb the shock of recoil of the gun and return it into battery. For details of functioning of the group, see Section XV.

77. Maintenance by Ordnance Maintenance Personnel

a. **DISASSEMBLY.** (1) Remove the gas cylinder sleeve group (par. 73) and remove the trunnion blocks (par. 60*a*).

(2) Extract cotter pin and back off gas cylinder bracket clamp screw nut several turns.

(3) Straighten the tab of the gas cylinder bracket lock and unscrew the gas cylinder bracket nut (fig. 84). It will be noted that the helical recoil spring is decompressed slowly as the nut is backed off. Never remove the bracket nut without first loosening the bracket clamp screw (fig. 85). To do so would be dangerous, as the bracket would be thrown off with force by the recoil spring.

(4) Remove the screw, key, and nut from the gas cylinder bracket.

(5) Slide the bracket, front recoil spring seat, recoil spring, rear recoil spring seat, and the recoil housing assembly from the tube.

b. **ASSEMBLY.** (1) Install the recoil housing assembly, rear recoil spring seat, recoil spring and front recoil spring seat over the tube in the order given.

(2) Clean the bore of the gas cylinder bracket and also its bearing surface on the tube. Position the bracket on the tube with the side nearest the vent plug opening toward the muzzle of the gun.

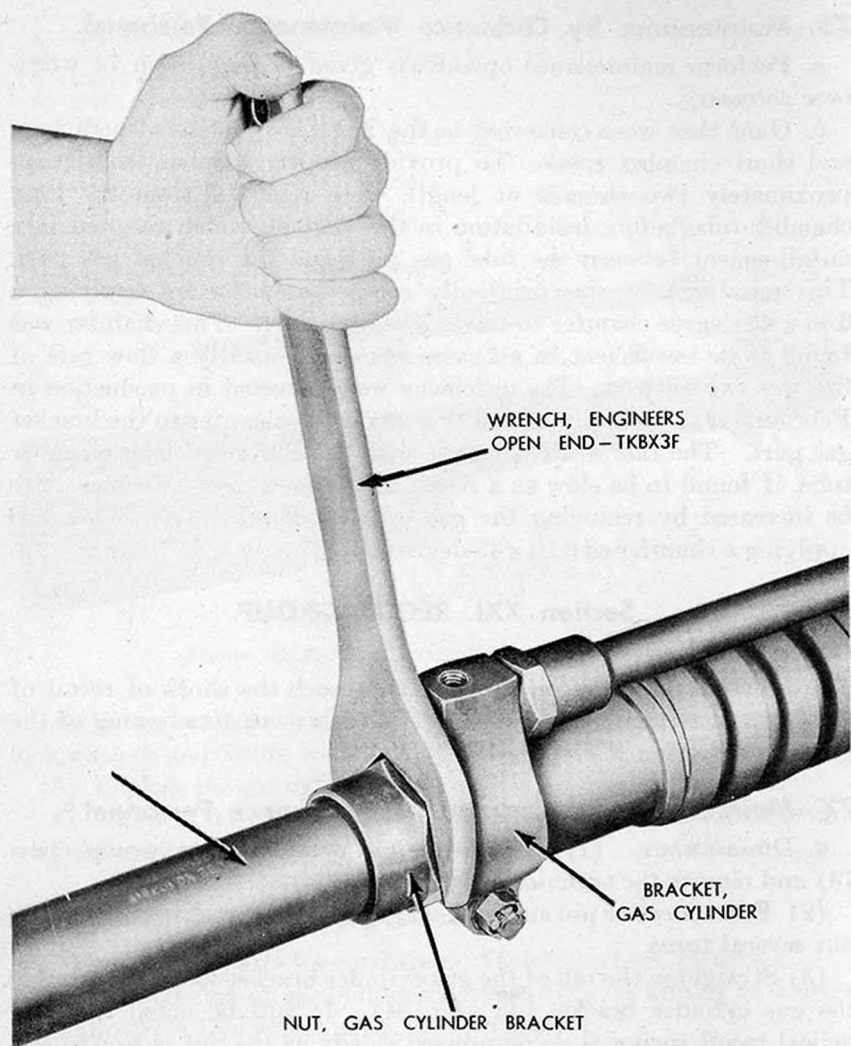

Figure 84. Removing gas cylinder bracket nut.

RA PD 91046

(3) Position the key in the slot at the bottom of the bracket and align it with the keyway in the tube. Install the clamp screw and nut and tighten lightly to hold clamp screw assembly in place.

(4) Install a new bracket lock with the tang located in keyway of the tube.

(5) Position the front spring seat to have flat directly on top (fig. 86). This allows clearance for the gas cylinder hex head.

(6) Install the bracket nut and tighten until gas cylinder bracket is seated against tube shoulder. Have the nut drawn up snug and

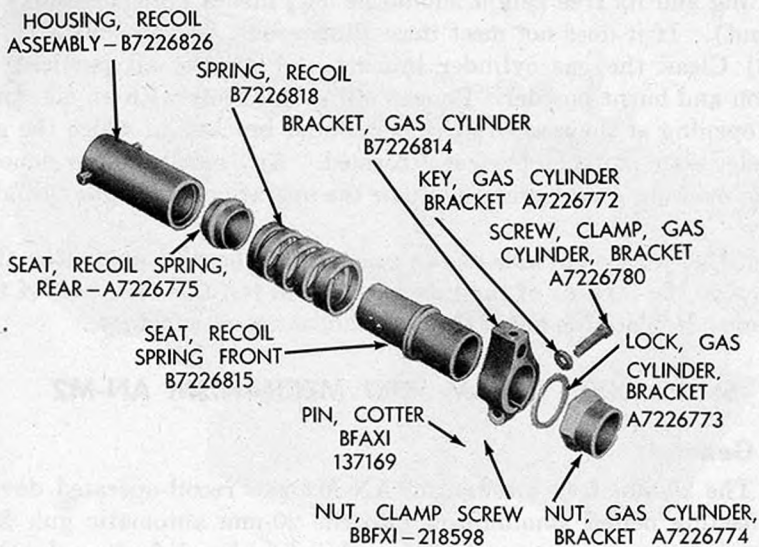

Figure 85. Parts of recoil group.

RA PD 91050

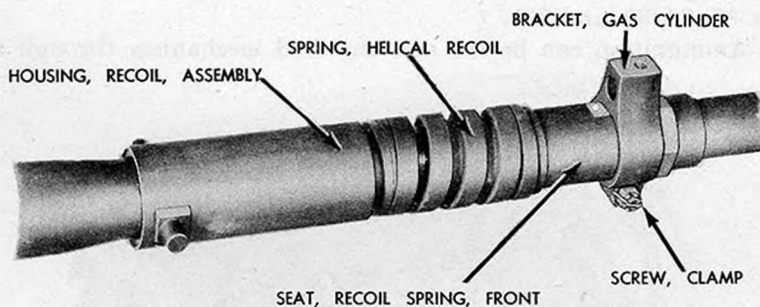

Figure 86. Positioning parts of recoil group.

RA PD 91043

secure by bending an edge of the bracket lock down over one flat of the nut.

(7) Position trunnions of the ring spring housing in a horizontal position. Tighten nut on clamp screw and install cotter pin.

c. MAINTENANCE. (1) Wash all these parts in dry cleaning solvent with the exception of the recoil housing assembly.

Note. Ring spring assemblies are lubricated at initial assembly and must not be immersed in cleaning solvents.

Clean the outside of the housing with a dry cloth and inspect the sleeves in both ends for proper staking. If the recoil housing assembly is damaged, do not attempt to repair it; replace it.

(2) The helical recoil spring should not show any evidence of

buckling and its free height should be $5\frac{5}{64}$ inches (plus or minus 10 percent). If it does not meet these dimensions, do not reinstall.

(3) Clean the gas cylinder bracket and remove all particles of carbon and burnt powder. Remove all rough spots with an oil stone. The opening at the rear of the gas cylinder bracket, in which the gas cylinder seats, must be perfectly formed. Any mutilation or deposit in this opening would greatly impair the operation of the gas cylinder group.

(4) Inspect the threads of the gas cylinder bracket nut. Run this nut up on the threads of the tube by hand to test the condition of the threads. Replace the nut if the thread fit is not satisfactory.

Section XXII. 20-MM FEED MECHANISM AN-M2

78. General

a. The 20-mm feed mechanism AN-M2 is a recoil-operated device for feeding belted ammunition into the 20-mm automatic gun M3. There are two distinct mechanisms, the right-hand feed mechanism which feeds ammunition into the gun from the right-hand side, and the left-hand feed mechanism which feeds from the left-hand side (figs. 87, 88, 89, and 90).

b. Ammunition can be led into the feed mechanism through the

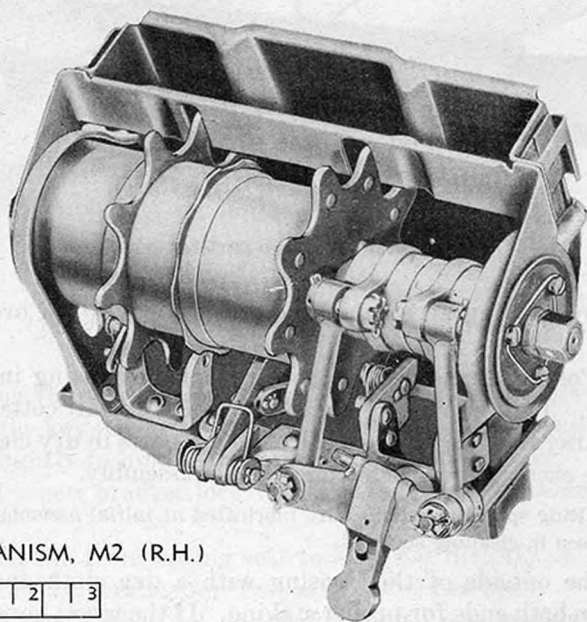

MECHANISM, M2 (R.H.)

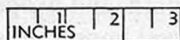

RA PD 93928

Figure 87. 20-mm right-hand feed mechanism AN-M2—Right side view.

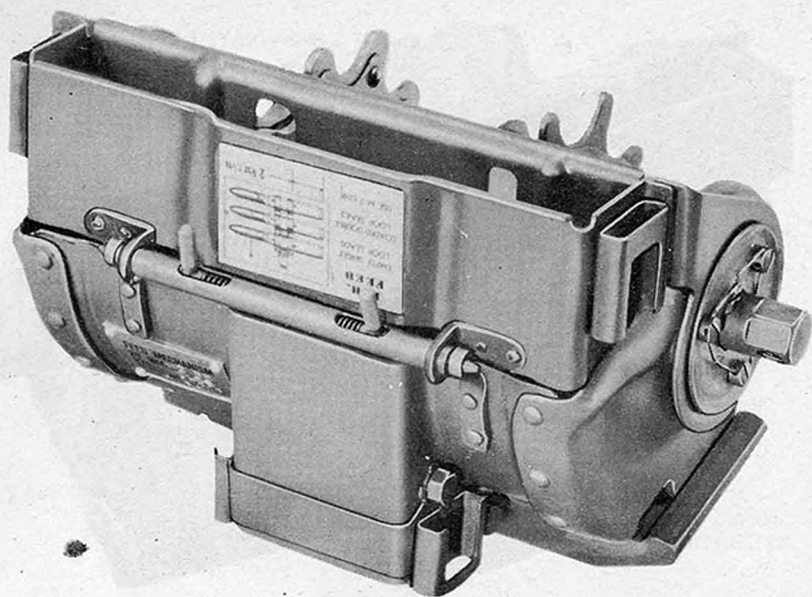

RA PD 93929

Figure 88. 20-mm right-hand feed mechanism AN-M2—Left side view.

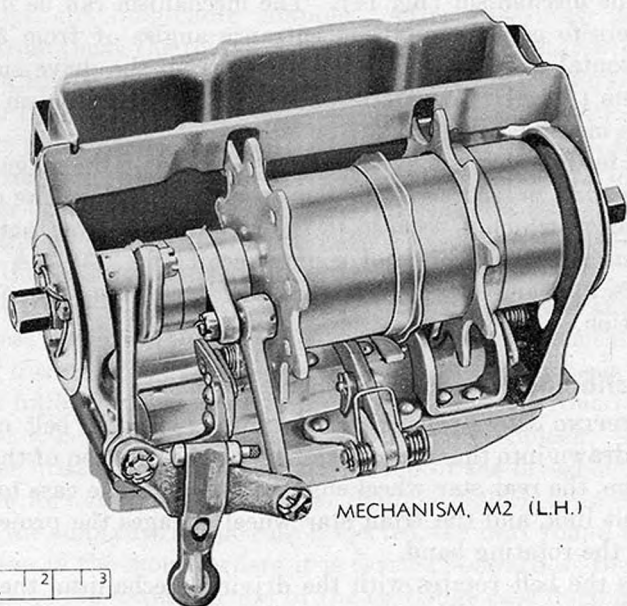

MECHANISM, M2 (L.H.)

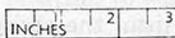

RA PD 93930

Figure 89. 20-mm left-hand feed mechanism AN-M2—Left side view.

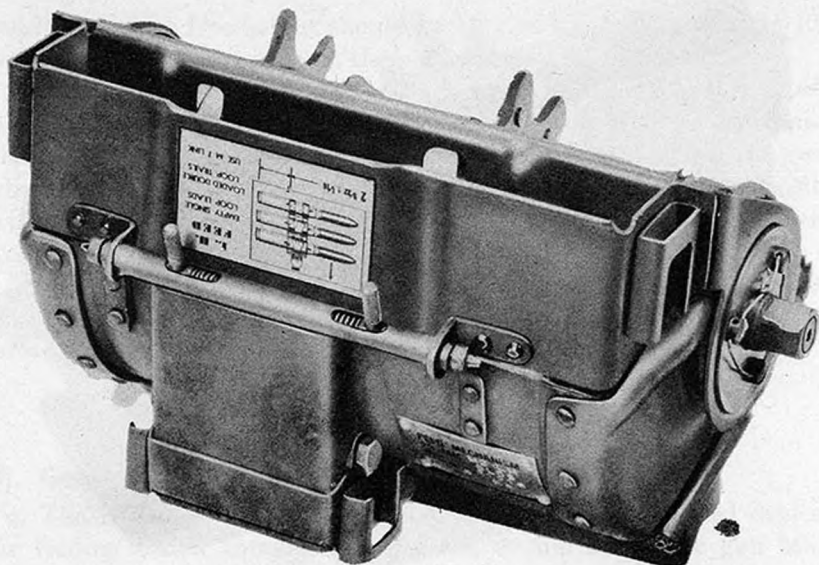

RA PD 93931

Figure 90. 20-mm left-hand feed mechanism AN-M2—Right side view.

feed chute adapter at an angle of 75° above the horizontal on the drive side of the mechanism (fig. 14). The mechanism can be fitted with feed covers to give ammunition entrance angles of from 55° above the horizontal to 47° below the horizontal on the drive side of the mechanism (fig. 14). Ammunition belts for this mechanism are made of 20-mm metallic belt links M7 or M8.

c. The feed mechanism as a whole is mounted on the magazine slide which, in turn, is secured to the non-recoiling cradle. The operating lever bracket, which is secured to the recoiling receiver, actuates the mechanism during recoil and counterrecoil (fig. 13). A recoil of between $\frac{5}{8}$ inch and $1\frac{3}{16}$ inches is satisfactory to keep the mechanism in operation.

79. Functioning

a. STRIPPING AND FEEDING OF ROUNDS. (1) As a belt of ammunition is drawn into the feed mechanism by the rotation of the driving mechanism, the rear star wheel engages the cartridge case to the rear of the belt link, and the front star wheel engages the projectile just ahead of the rotating band.

(2) As the belt rotates with the driving mechanism, the stripper cams wedge between each cartridge case and the ears of the belt links, thus stripping the links from the cartridges (fig. 91). During the stripping action, the single end of the link is guided into the link chute by the link deflector (fig. 91), while the double end is being

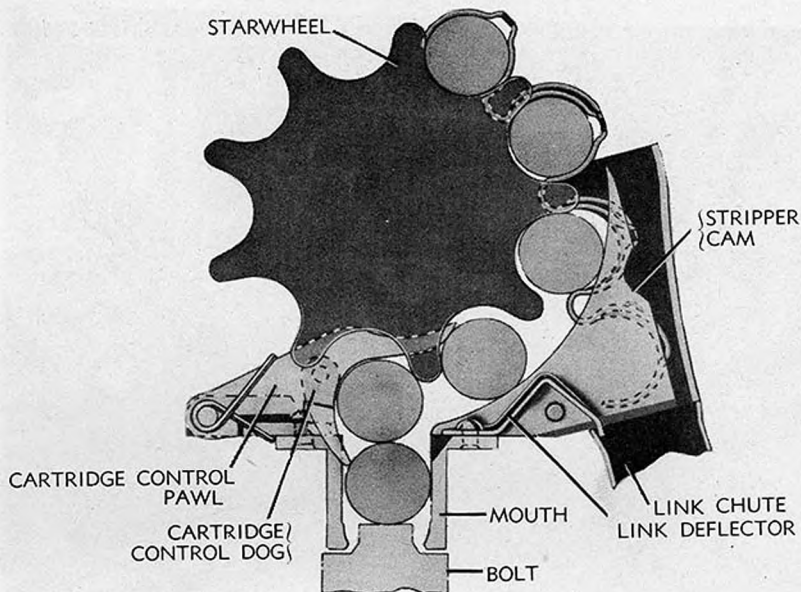

RA PD 93936

Figure 91. 20-mm feed mechanism AN-M2—Stripper cam action.

cammed from the round. The link is ejected from the feed mechanism through the link chute adapter. After the links have been stripped from them, the rounds are carried on by the star wheel until they are in line with the mouth. At this point, they are guided into the mouth by the front and rear cartridge guides (fig. 92). As the rounds are guided into the mouth by the cartridge guides, they contact the front and rear spring-operated cartridge holding cams and force them aside (fig. 93). The cams prevent the rounds from re-entering the feed after they have been forced into position in the mouth of the feed mechanism (figs. 94 and 95).

(3) The round is positioned in the bottom of the mouth at an angle of 3 degrees and 20 minutes. The round is held in position in the bottom of the mouth by the force exerted by the star wheels through the round following. This angle properly directs the round into the chamber as it is being carried forward by the breechblock. The next round to be fired is forced downward on top of the breechblock when it is in the forward position. When the breechblock is forced rearward and the empty cartridge case is ejected, the next round is forced into position in the mouth where it is carried forward as the breechblock contacts the lower portion of the cartridge case during its forward travel.

(4) Just before the incoming rounds enter the feed mouth, they contact the lower side of the spring-loaded cartridge control pawl, raising it slightly. This action lifts the cartridge holding dog, allow-

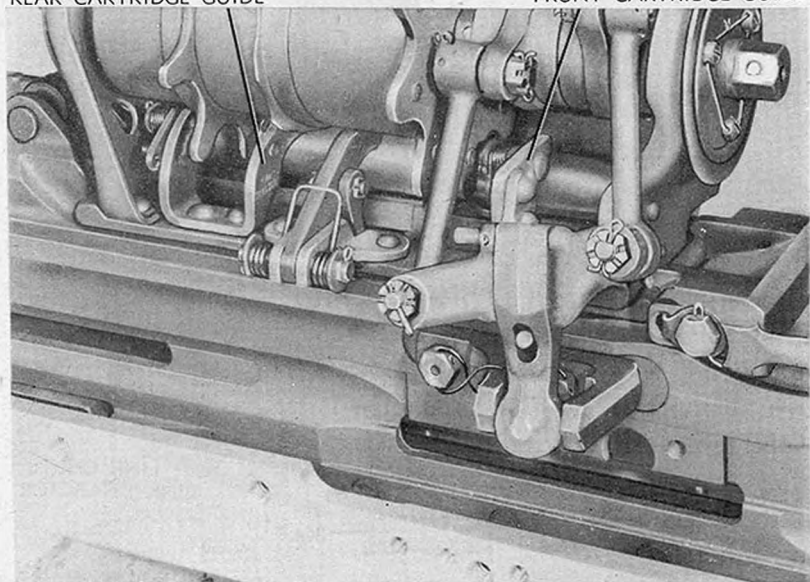

RA PD 93937

Figure 92. 20-mm feed mechanism AN-M2—Action of cartridge guides.

ing the cartridges to enter the mouth (fig. 96). When the last round has passed under the control pawl and entered the mouth of the feed, the control pawl spring forces the pawl downward so that the holding dog prevents the last round from dropping all the way down into the mouth of the feed mechanism. If the last round should drop into the path of the breechblock, it would cause the gun to jam. The last round in the belt is held in such a position by the holding dog that the breechblock will not contact it and jam the gun as it closes on the empty chamber. This round is also positioned so that it clears the star wheels, permitting them to spin and automatically unwind the drive spring when the last two rounds have entered the mouth. The last round, held by the holding dog, is released and forced into the feeding position in the mouth by the action of the first round of a new belt on the cartridge control pawl and dog. When the last round leaves the star wheels and enters the feed mouth, the cartridge holding cams are forced over the top of the cartridge by the cartridge holding cam springs (fig. 95). The holding cams prevent the last two rounds in the mouth from reentering the feed and, in so doing, position the lower round in the mouth so it can be stripped out by the breechblock.

b. OPERATION OF FEED MECHANISM (FIGS. 97 AND 98). (1) The driving mechanism is powered by the drive spring which is wound by the recoil of the gun. As the gun recoils and counterrecoils, the operating lever actuates the link operating crank; the crank, in turn, actu-

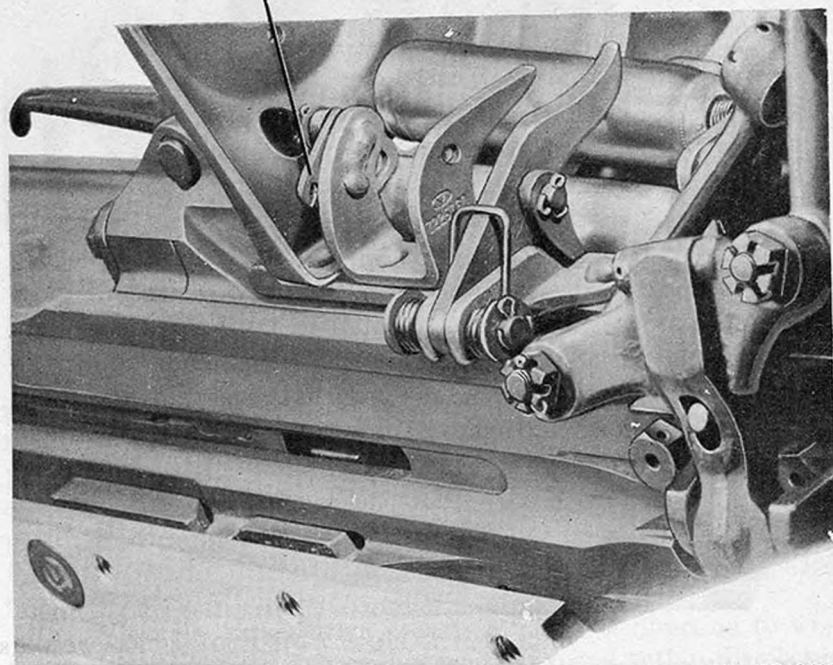
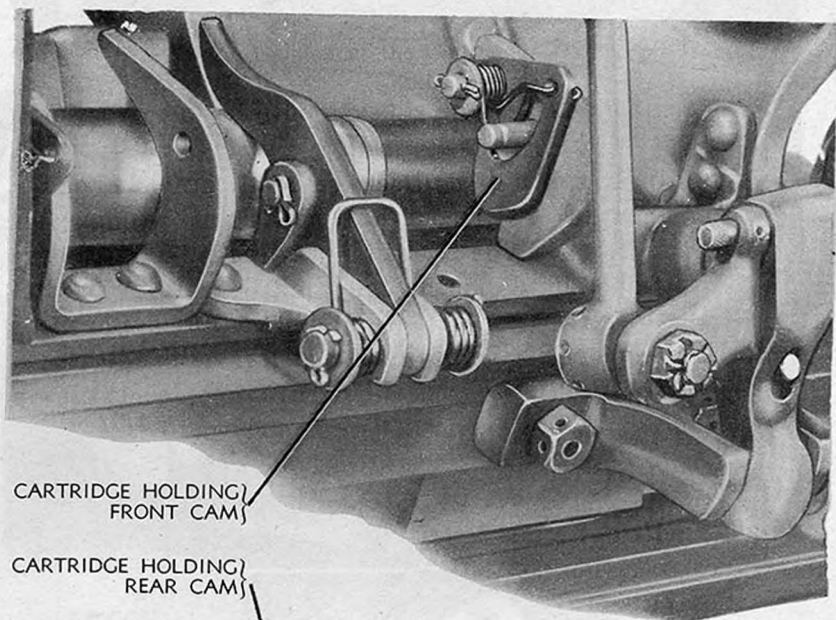

RA PD 94119

Figure 93. 20-mm feed mechanism AN-M2—Incoming cartridges passing the holding cams.

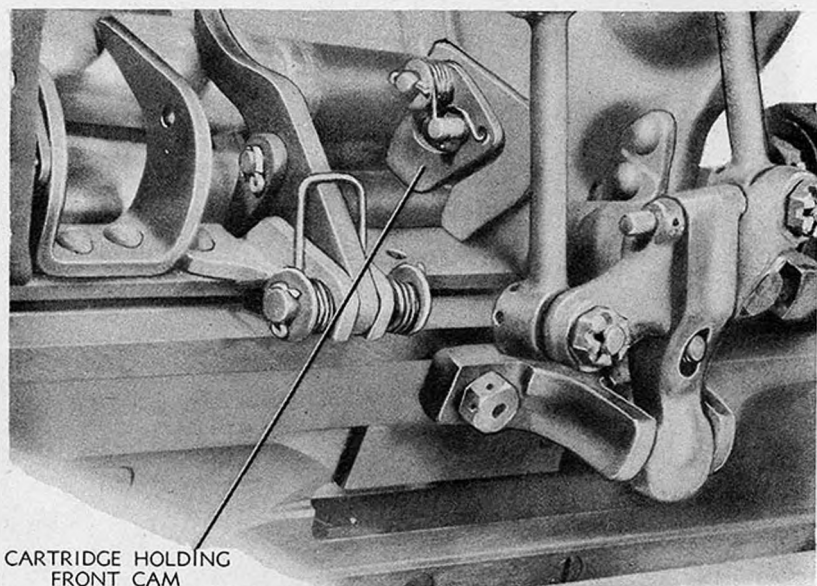

CARTRIDGE HOLDING
FRONT CAM

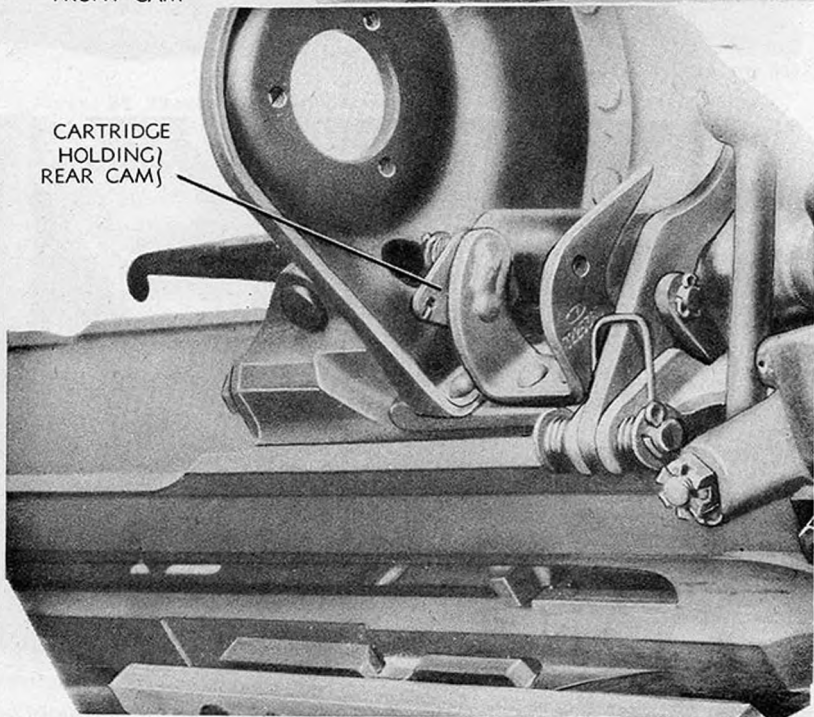

CARTRIDGE
HOLDING }
REAR CAM }

RA PD 94118

Figure 94. 20-mm feed mechanism AN-M2—Holding cams preventing cartridges from reentering feed mechanism.

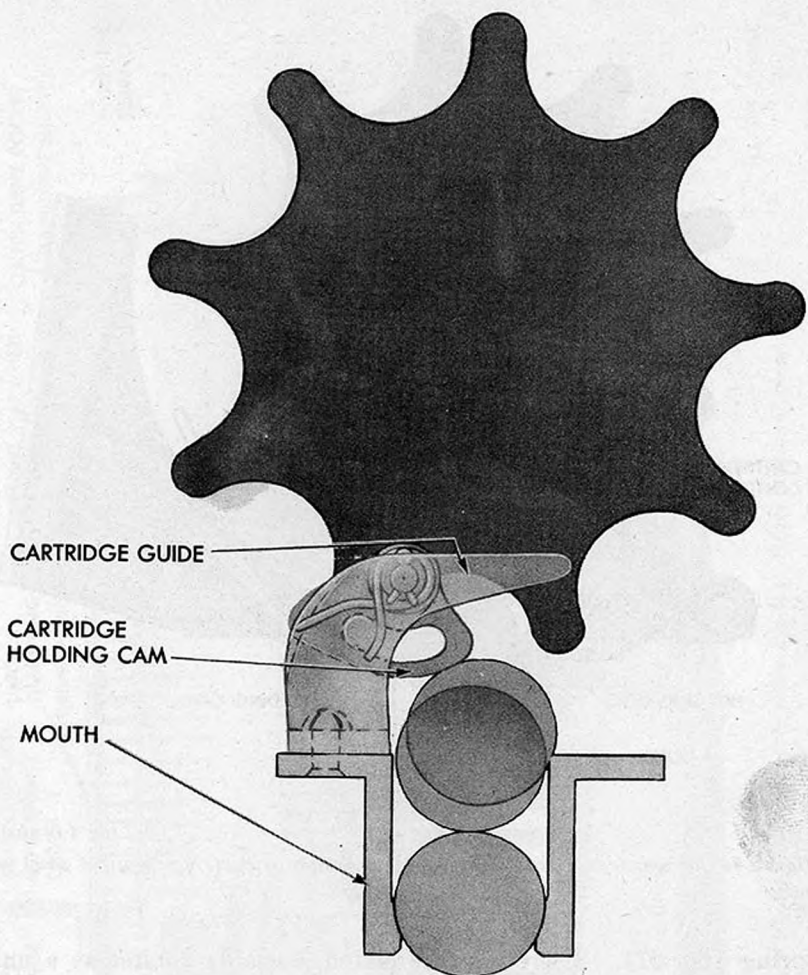

RA PD 94038

Figure 95. 20-mm feed mechanism AN-M2—Action of cartridge holding cam.

ates the two link assemblies which connect the operating crank with the clutch drive pockets (fig. 97). During recoil, the rear clutch drive pocket transmits motion to the main drive shaft through the clutch spring and hub while the front clutch freewheels. During counter-recoil, the action of the front and rear clutches is reversed. Thus, the forward and backward motion of the operating lever is changed into rotary motion to actuate the main shaft assembly.

(2) When the clutch drive pockets rotate in a direction to wind the drive spring, the clutch springs tend to expand within the pockets (fig. 97). The force of this expansion causes the clutch spring to grip and be carried with the pocket as it rotates. The clutch driven hub is pinned to the main drive shaft and is also locked to the clutch

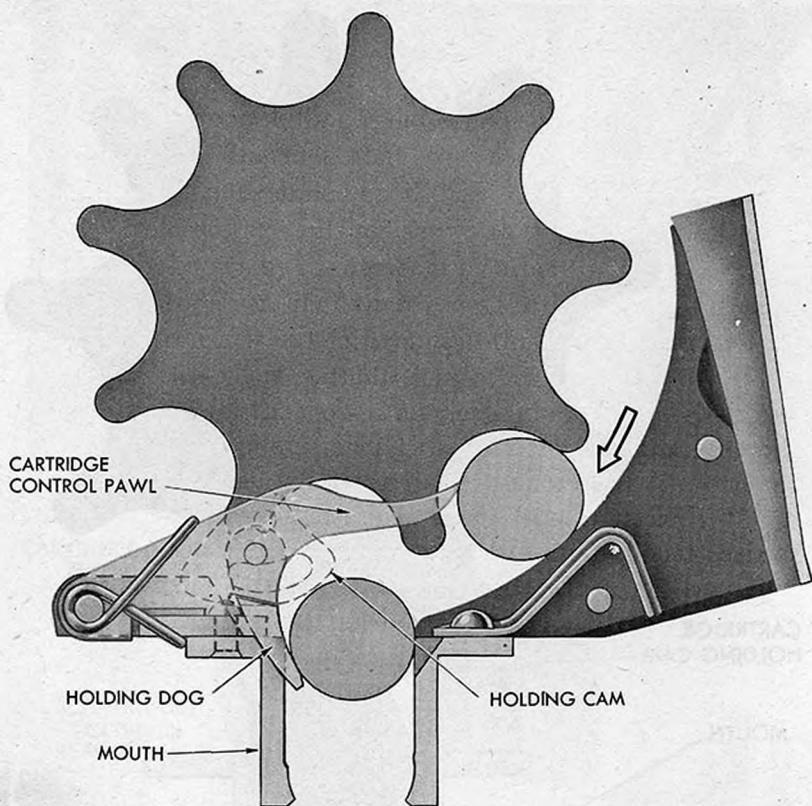

RA PD 108033

Figure 96. 20-mm feed mechanism AN-M2—Action of cartridge control pawl and holding dog.

spring (fig. 97). Therefore, the clutch assembly rotates as a unit, turning the main drive shaft which winds the drive spring through the drive spring driver hub (fig. 97). While one clutch assembly is revolving in the winding direction, the other revolves in the opposite direction, causing the clutch spring to contract within the pocket, thus relaxing its grip. This permits the pocket to revolve freely in the opposite direction to its clutch driven hub and spring, which always revolve with the main shaft. This action causes the main drive shaft to always be rotated in a direction to wind the drive spring, even though the clutch drive pockets are reversing their direction every half cycle of gun operation.

(3) As the main drive shaft is rotated, the small end of the drive spring grips and revolves with the drive spring driver (fig. 97). This winds the larger portion of the drive spring. The front end of the drive spring is anchored to the front star wheel which it rotates. Overwinding of the drive spring is prevented by the torque stabilizer

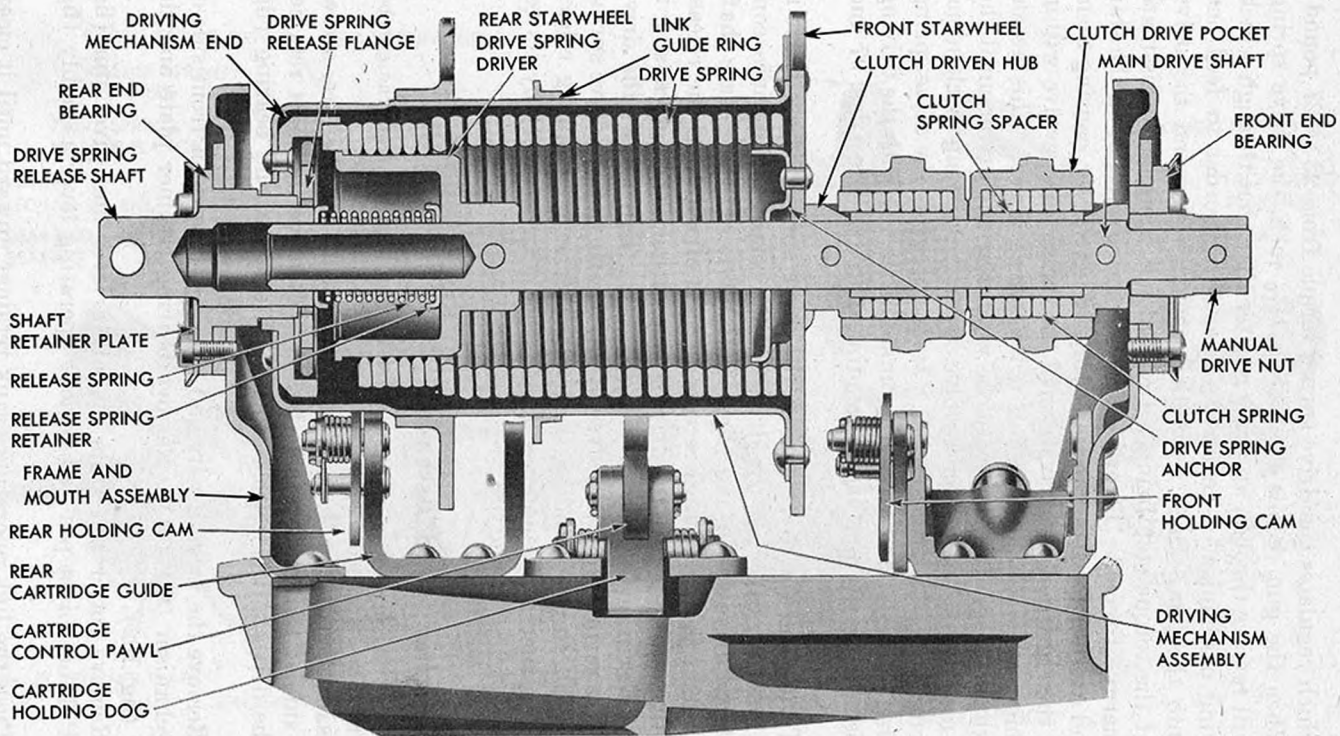

Figure 97. 20-mm feed mechanism AN-M2—Cross sectional view.

RA PD 108031

action which regulates the drive spring torque from 23 to 27 pound-feet. When the gun recoils more than $1\frac{1}{16}$ inch, the drive spring driver will revolve through an angle greater than that through which the driving mechanism is required to revolve in order to feed one round into the gun. Such a condition would overwind the drive spring if the torque stabilizing action did not function to dissipate excess energy of recoil. To overcome this, the projection on the star wheel end exerts a force on the small coils of the spring, causing them to relax their grip on the driver, until the driver can revolve within the spring and still maintain full drive spring force. This action insures that the spring will always be wound by the driver until the driving mechanism end, which revolves with the driving mechanism, is contacted by the drive spring lug. It also prevents the drive spring from being overwound because the contact of the lug with the driving mechanism end prevents further winding of the spring (figs. 97 and 98).

(4) To unwind the drive spring, the drive spring release shaft is pushed forward, carrying the drive spring release flange into contact with the drive spring lug (figs. 97 and 98). If the release shaft is revolved in the opposite direction to that of winding, the release flange will exert a force on the drive spring through the lug, causing it to relax its grip on the drive spring driver. This allows the drive spring to be revolved on the driver by the rotation of the drive spring release shaft, thus unwinding the spring. The drive spring release shaft is returned to its nonoperating position (rearward) by its release spring (figs. 97 and 98).

80. Disassembly and Assembly

Note. The feed mechanism must be unloaded and removed from the gun before it is to be disassembled.

a. **DISASSEMBLY.** (1) Remove the locking wire and the three screws on rear side of feed mechanism (fig. 99). Remove the shaft retainer plate, the drive spring release shaft, and the rear end bearing (fig. 100).

(2) Remove the locking wire and the three screws on front side of feed mechanism (fig. 101). Remove bearing retainer plate and the bearing (fig. 102).

(3) Remove cotter pin from operating lever and pivot pin (fig. 102). Pull out pivot pin and remove operating lever assembly (fig. 102).

(4) Push the link operating crank retainer upward until it clears the groove in the operating lever pivot bracket (fig. 103).

(5) Unlock feed chute adapter from feed frame and remove the adapter.

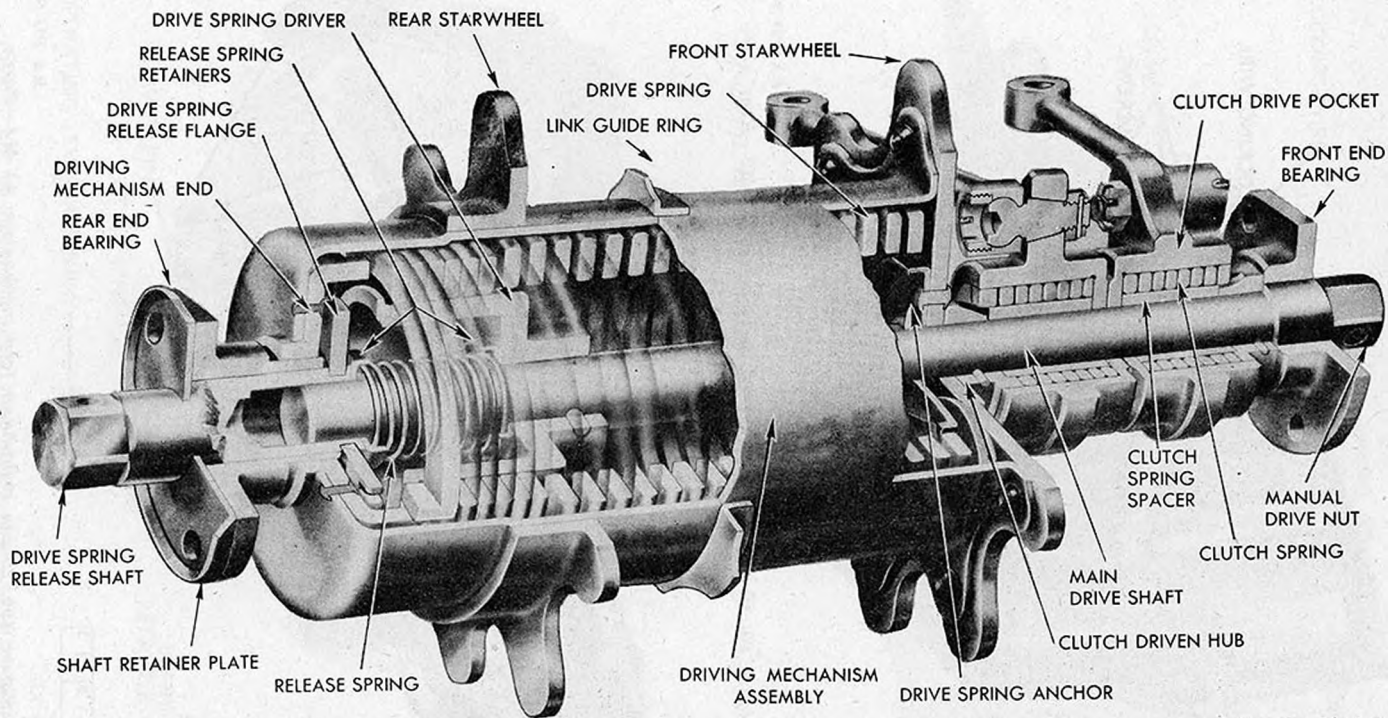
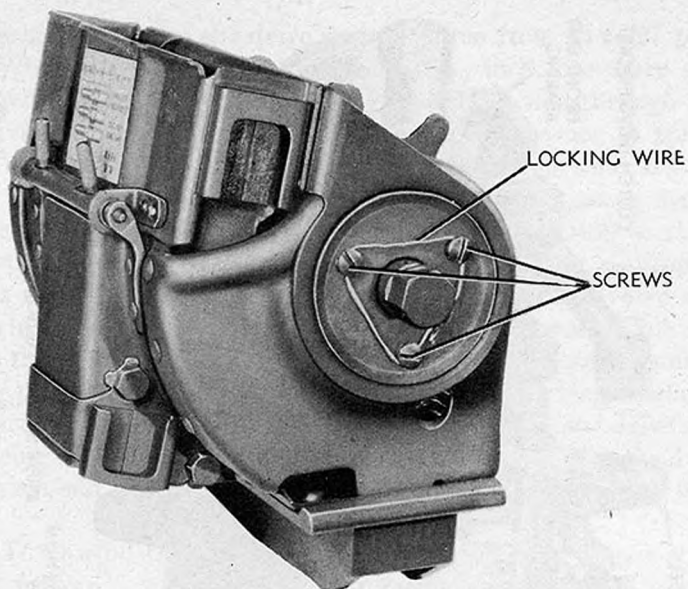

Figure 98. 20-mm feed mechanism AN-M2—Cross sectional view of driving mechanism and clutch groups.

RA PD 108032



RA PD 94039

Figure 99. 20-mm right-hand feed mechanism AN-M2—Rear side.

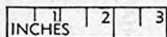
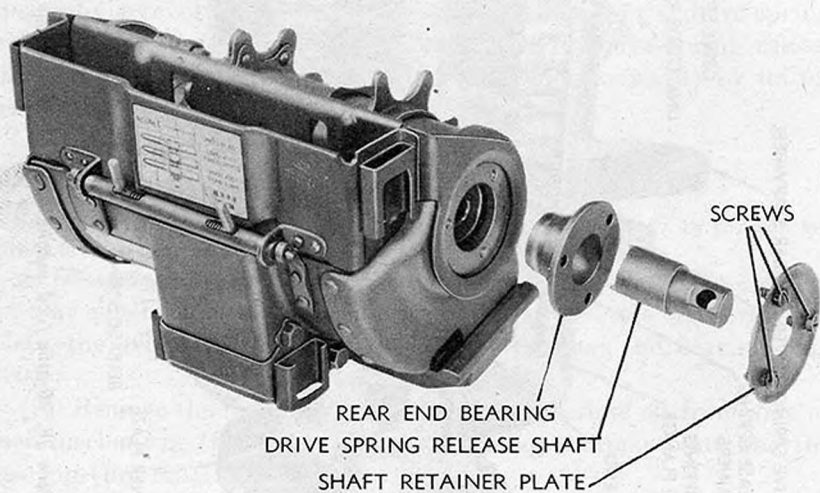

RA PD 94040

Figure 100. 20-mm right-hand feed mechanism AN-M2—Parts removed from rear side.

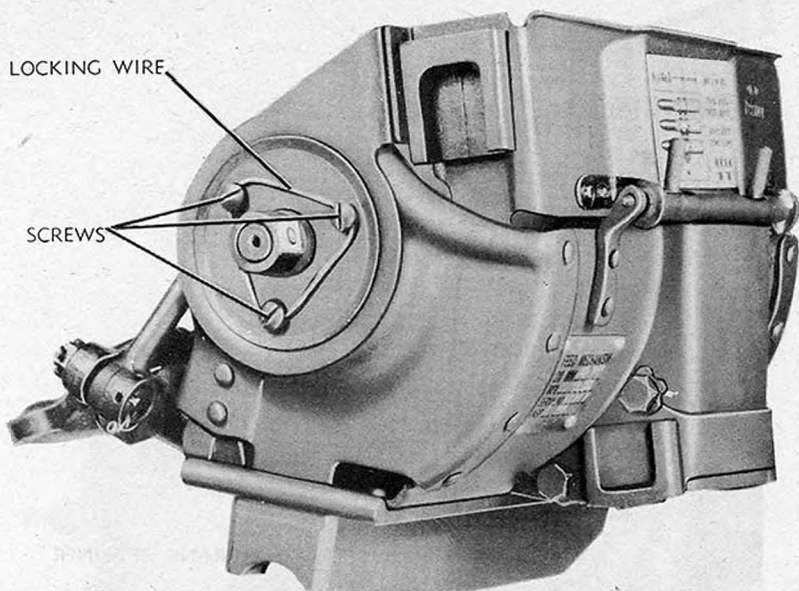

RA PD 94041

Figure 101. 20-mm right-hand feed mechanism AN-M2—Front side.

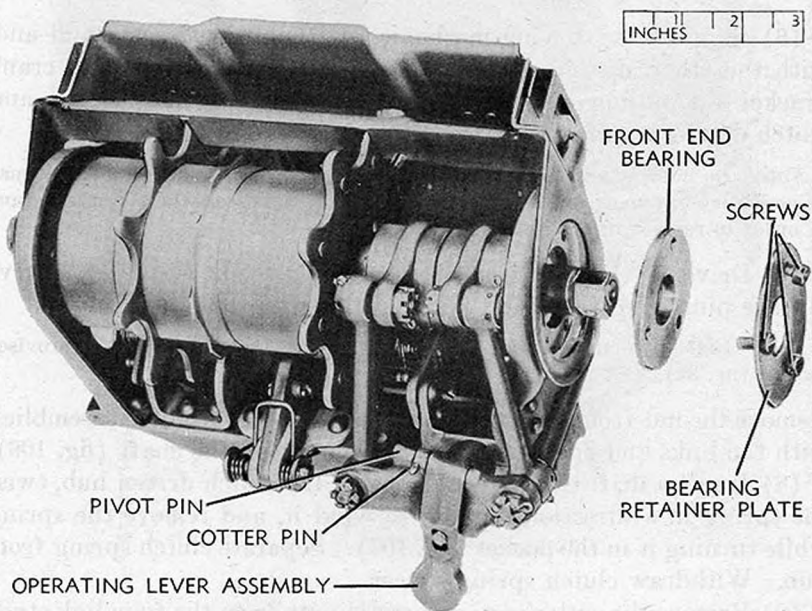

RA PD 94042

Figure 102. 20-mm right-hand feed mechanism AN-M2—Parts removed from front side.

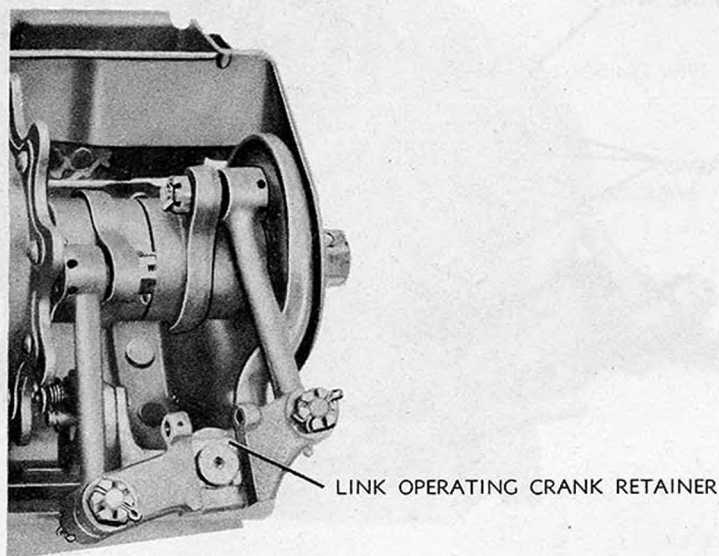

RA PD 94043

Figure 103. 20-mm right-hand feed mechanism AN-M2—Removal of link operating crank retainer.

(6) Support the driving mechanism assembly with one hand and, with the other, disconnect the link operating crank from the crank bracket by pulling outward, and remove driving mechanism and clutch drive group from the feed frame (fig. 104).

Note. Do not damage these parts by forcing them. In some instances it may be necessary to remove one or two of the link ball studs from the operating crank in order to remove it.

(7) Drive out the rivet from the manual drive nut (fig. 105). Drive out the pins from front and rear clutch driven hubs (fig. 105).

Note. In driving out the pins, it is best to support the group on an improvised fixture (fig. 33).

Remove the nut from the shaft (fig. 106). Slide the clutch assemblies with the links and operating crank as a unit, off the shaft (fig. 106).

(8) Insert a drift through the holes of the clutch driven hub, twist the spring in a direction tending to wind it, and remove the spring while turning it in the pocket (fig. 107). Separate clutch spring from hub. Withdraw clutch spring spacer.

(9) Remove the cotter pins and castle nuts from the four link studs (fig. 108). Remove the cotter pins from the four link plugs and unscrew the four plugs (fig. 108). Drive out the studs with a soft hammer, taking care not to damage the threads (fig. 108).

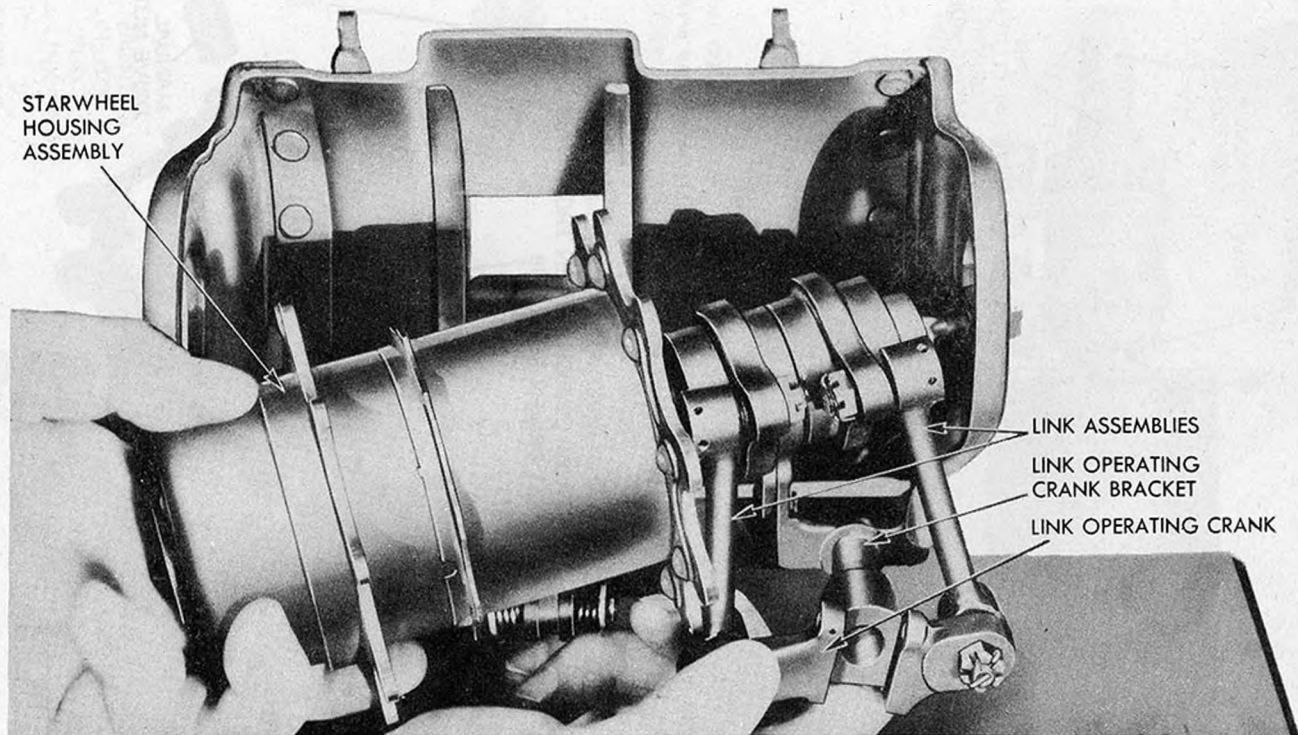

RA PD 94044

Figure 104. 20-mm right-hand feed mechanism AN-M2—Removal of driving mechanism and clutch drive group.

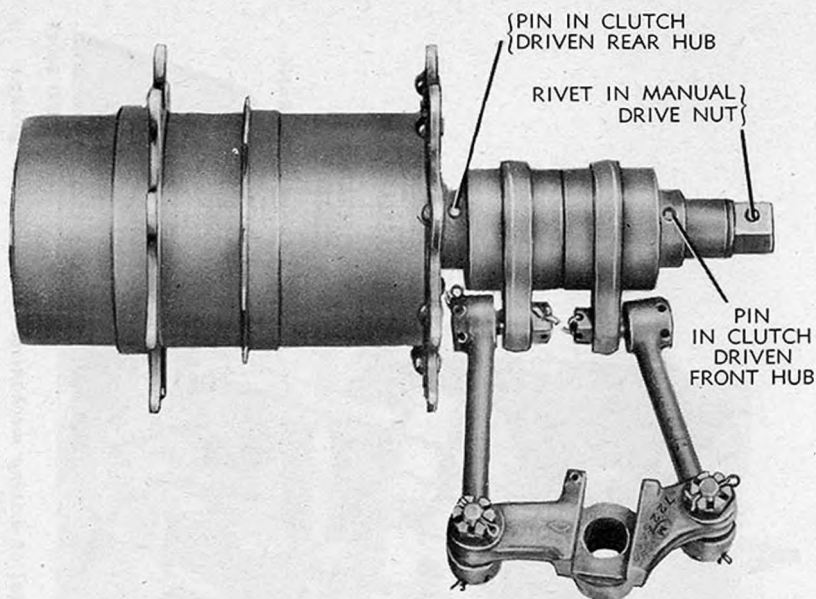

RA PD 108059

Figure 105. 20-mm right-hand feed mechanism AN-M2—Clutch drive and driving mechanism group.

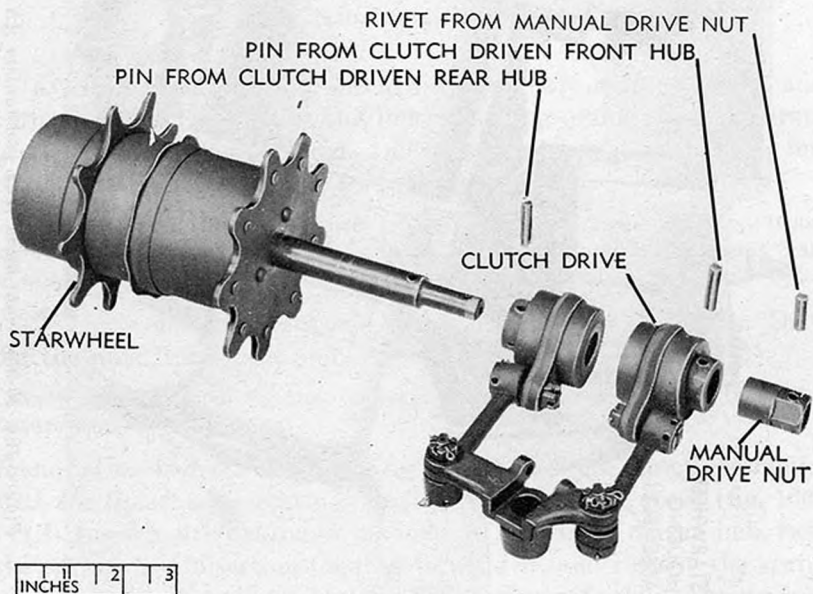

RA PD 108060

Figure 106. 20-mm right-hand feed mechanism AN-M2—Clutch drive disassembled from driving mechanism.

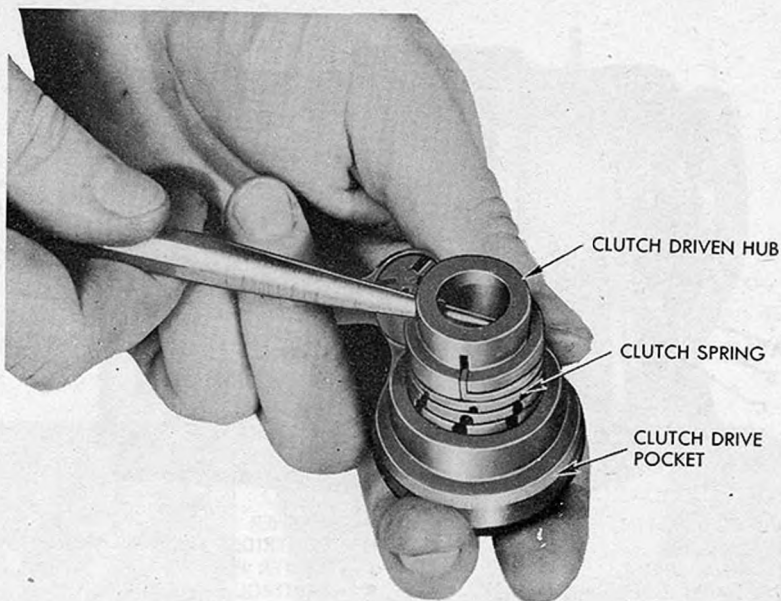

RA PD 64836

Figure 107. 20-mm feed mechanism AN-M2—Removal of clutch spring.

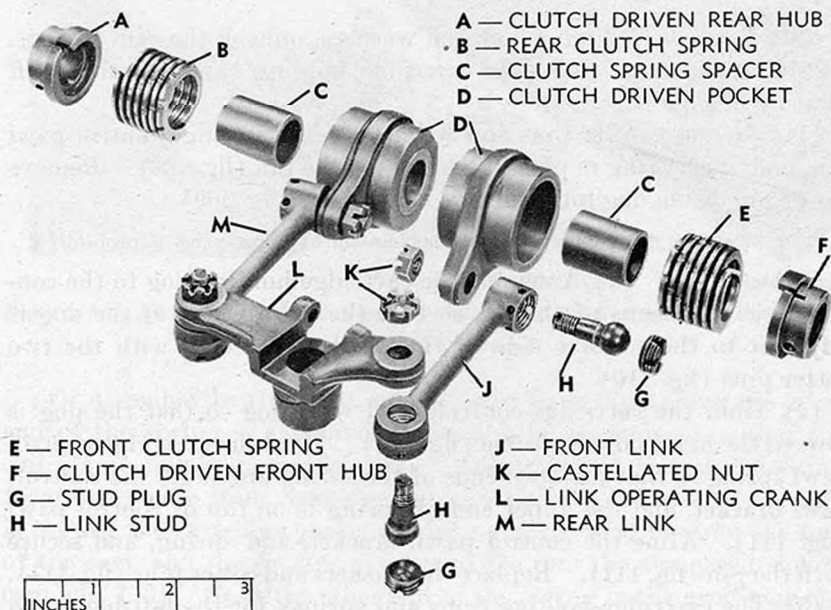

RA PD 94049

Figure 108. 20-mm right-hand feed mechanism AN-M2—Clutch drive parts.

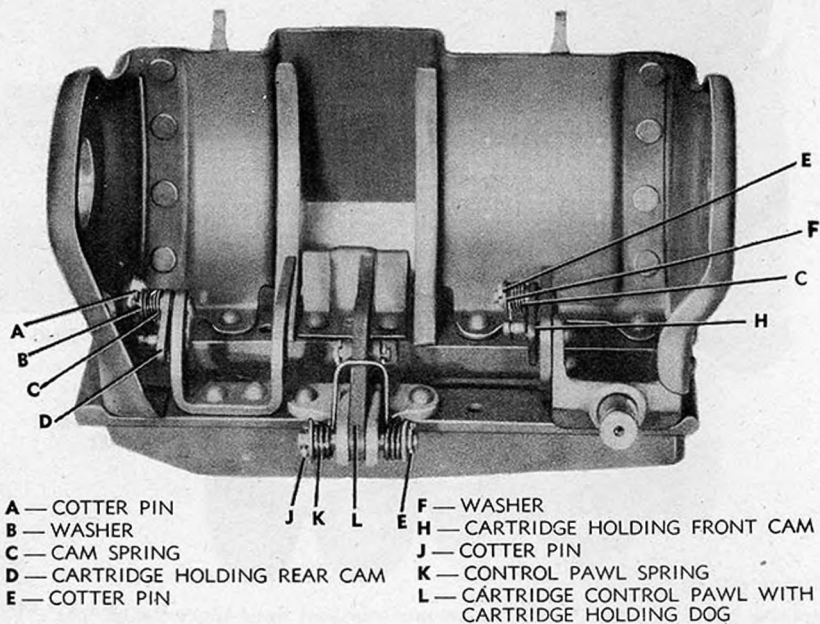

RA PD 94051

Figure 109. 20-mm right-hand feed mechanism AN-M2—Disassembly of feed frame group.

(10) Remove the cotter pins and washers, unhook the cam springs, and slide the front and rear cartridge holding cam assemblies off their pivot pins (fig. 109).

(11) Remove cotter pins and washers from cartridge control pawl pin, hold dog spring in place, and pull out the pin (fig. 109). Remove cotter pins from dog pin and slide out the pin (fig. 109).

Note. Further disassembly of feed mechanism by using arms is prohibited.

b. ASSEMBLY. (1) Assemble the cartridge-holding dog to the control pawl by means of the pin so that the convex side of the dog is adjacent to the concave side of the pawl, and secure with the two cotter pins (fig. 110).

(2) Hold the cartridge-control pawl with dog so that the dog is toward the mouth of the frame (fig. 111). Hold the cartridge-control pawl spring so that the open ends of the spring are under the control-pawl bracket, and the upper end of spring is on top of control pawl (fig. 111). Aline the control pawl, bracket, and spring, and secure with the pin (fig. 111). Replace the washers and cotter pins (fig. 111).

(3) The cartridge-holding cams and springs for the left-hand and right-hand feed mechanisms are different. Before installing the cartridge-holding cams and springs, select the proper cams and springs for left-hand or right-hand feed mechanism (fig. 112).

CARTRIDGE CONTROL PAWL

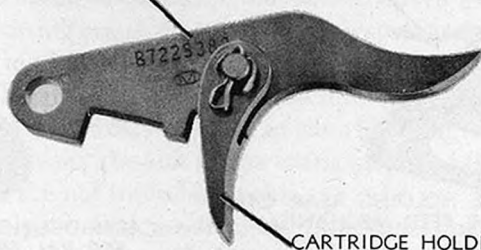

CARTRIDGE HOLDING DOG

RA PD 94050

Figure 110. 20-mm feed mechanism AN-M2—Cartridge-holding dog assembled to cartridge-control pawl.

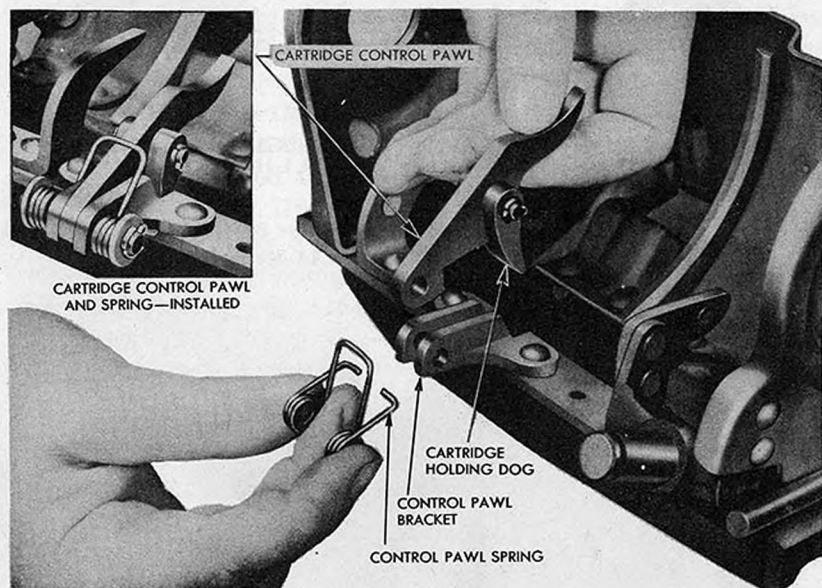

CARTRIDGE CONTROL PAWL
AND SPRING—INSTALLED

CARTRIDGE
HOLDING DOG

CONTROL PAWL
BRACKET

CONTROL PAWL SPRING

RA PD 94052

Figure 111. 20-mm right-hand feed mechanism AN-M2—Installing cartridge-control pawl.

(4) Assemble the front cam spring to the front cam so that the offset end of the spring is anchored in small hole in cam and so that the coil fits on hub of cam (fig. 112). Assemble the cartridge holding front cam to the front cartridge guide so that the flat side of the cam is toward the cartridge guide, the longer pivot stud fits into the hub of the cam, and the shorter pivot stud fits into the elongated slot in cam (fig. 113). Snap the other end of the spring in the groove on the lower side of the shorter pivot stud (fig. 113). Assemble the washer and secure with the cotter pin (fig. 109). Similarly assemble the cartridge-holding rear cam.

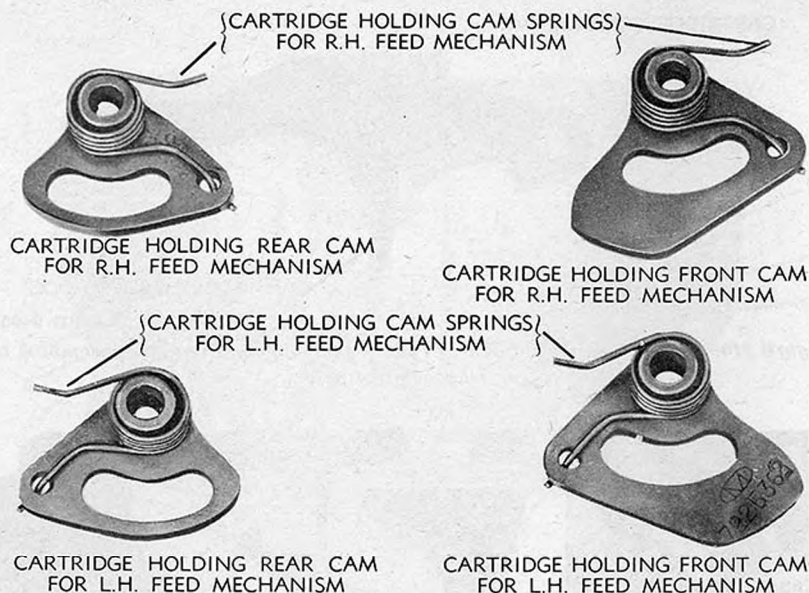

Figure 112. Cartridge-holding cams and springs for 20-mm left-hand and right-hand feed mechanisms AN-M2.

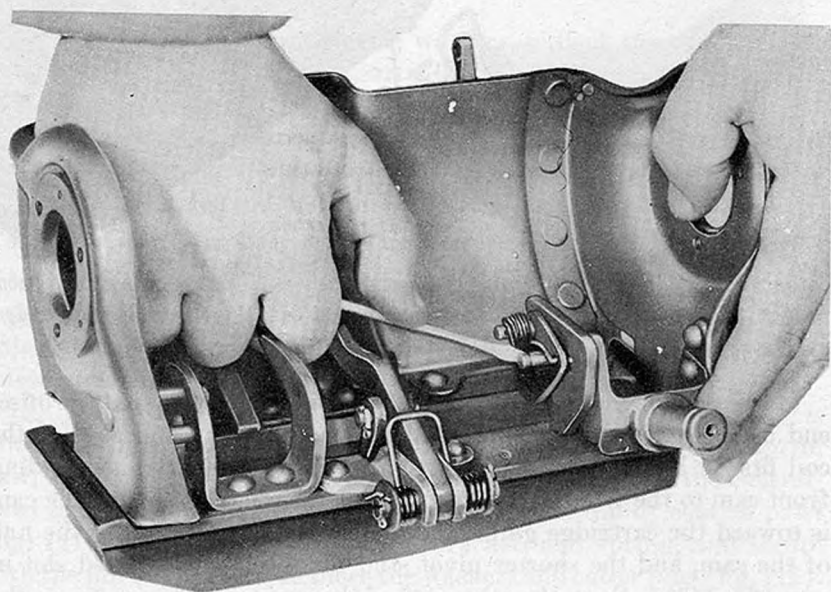

Figure 113. 20-mm right-hand feed mechanism AN-M2—Installing cartridge holding front cam with spring.

(5) Before proceeding to assemble the clutch drive group, select the correct link operating crank, links, and clutch springs for left-hand or right-hand feed mechanism from the following instructions:

(a) For a right-hand feed mechanism, the link operating crank has a slot (for the operating lever) sloping to the right (fig. 114); for a left-hand feed mechanism, the slot in the crank slopes to the left (fig. 114). These cranks are not interchangeable.

(b) For a right-hand feed mechanism, the front link is cupped downward at lower end and to the right at the upper end (fig. 115), while the rear link is cupped downward at lower end and to the left at the upper end (fig. 115). For a left-hand feed mechanism, the front link is cupped downward at lower end and to the left at upper end (fig. 115), while the rear link is cupped downward at lower end and to the right at upper end (fig. 115). The front link of a right-hand feed mechanism is interchangeable with the rear link of a left-hand feed mechanism, while the rear link of a right-hand feed mechanism is interchangeable with the front link of a left-hand feed mechanism.

(c) For a right-hand feed mechanism, the front clutch spring is left-hand winding (fig. 116), while the rear clutch spring is right-hand winding (fig. 116). For a left-hand feed mechanism, the front clutch spring is right-hand winding (fig. 116), while the rear clutch spring is left-hand winding (fig. 116). The front clutch spring of a right-

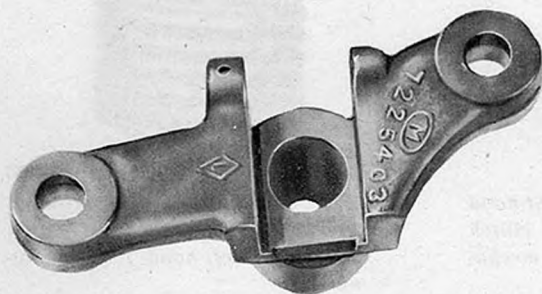

FOR R.H. FEED MECHANISM

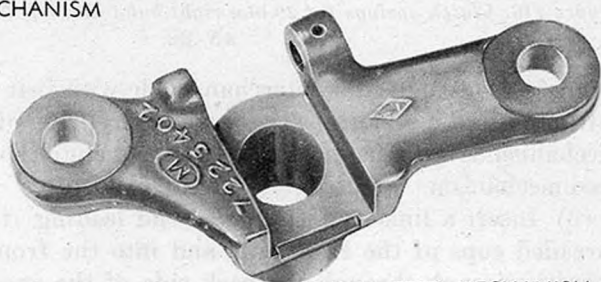

FOR L.H. FEED MECHANISM

RA PD 94055

Figure 114. Link operating cranks for 20-mm right-hand and left-hand feed mechanisms AN-M2.

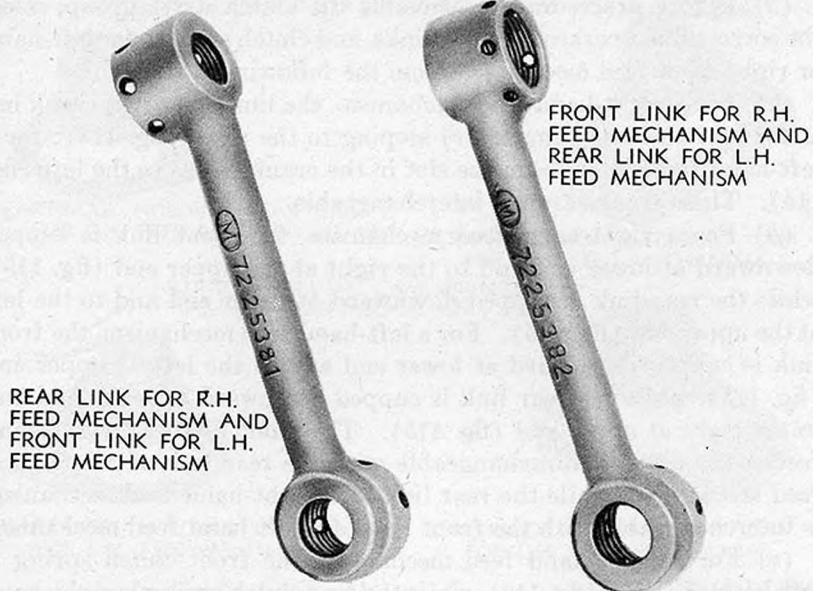

RA PD 94056

Figure 115. Links for 20-mm right-hand and left-hand feed mechanisms AN-M2.

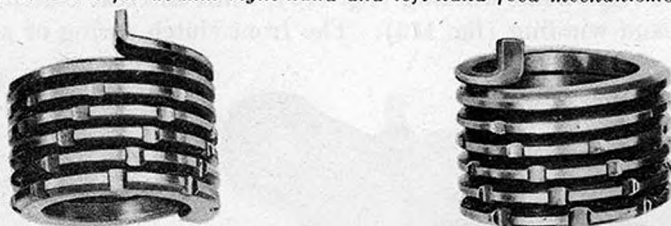

RA PD 94057

① Front clutch spring for right-hand feed mechanism and rear clutch spring for left-hand feed mechanism.

② Rear clutch spring for right-hand feed mechanism and front clutch spring for left-hand feed mechanism.

Figure 116. Clutch springs for 20-mm right-hand and left-hand feed mechanisms AN-M2.

hand feed mechanism is interchangeable with rear clutch spring of a left-hand feed mechanism; the rear clutch spring of a right-hand feed mechanism is interchangeable with a front clutch spring of a left-hand feed mechanism.

(6) Insert a link stud (threaded end leading) through one of the threaded cups of the front link and into the front hole of the link operating crank through the back side of the crank (fig. 108). Do not attempt to force the stud into the hole from the front side of the crank; the hole is tapered to receive the stud from the back side only. With a soft hammer, drive the stud into the crank, taking care not

to damage the threads. Replace the castle nut and cotter pin on the stud (fig. 108). Similarly, assemble the rear link to the link operating crank.

(7) Insert a link stud through the other threaded opening of the front link and into the drive clutch front pocket from the cupped side of the pocket (fig. 108). Do not attempt to force the stud into position from the uncupped side because the hole is tapered to receive the stud from the cupped side only. With a soft hammer, drive the stud into position, taking care not to damage the threads. Replace the castle nut and cotter pin on the stud (fig. 108). Similarly, assemble the rear link to the rear pocket.

(8) Screw in each of the four link plugs (cupped end leading) tightly and then back off the plugs (usually about one turn) until there is no bind or lash in the ball joint. Secure the plugs to the links with the cotter pins (fig. 108).

(9) Assemble the front clutch spring to the front hub and place a spring spacer into the spring (fig. 108). Insert a drift through the holes of the hub and twist and press the spring (with hub) into position in the front pocket (fig. 107). Similarly, assemble rear hub, spring, and spacer in rear pocket (fig. 117).

(10) Assemble the clutch drive group on the drive shaft with the rear pocket leading. Drive the two drive pins into the hubs and stake in place. Replace the manual drive nut, and drive in a new rivet and peen in place (figs. 105 and 106).

(11) Support the driving mechanism in the feed frame with the manual drive nut extending through the hole in front, and slide the link operating crank on its bracket (fig. 104).

(12) Slide the retainer into position in groove of bracket. Arms of retainer should point downward (fig. 103).

(13) Place the feed chute adapter in position on frame and lock it to the frame.

(14) Replace rear end bearing and then the drive spring release shaft and shaft retainer plate, and secure the plate and bearing to the frame with the three screws (fig. 100). Lock-wire the three screws (fig. 99).

(15) Replace front end bearing and plate and secure bearing and plate to frame with the three screws (fig. 102). Lock-wire the three screws (fig. 101).

81. Maintenance by Using Arms

a. Weekly and before firing, clean all accessible parts with dry cleaning solvent and then wipe with a cloth dampened with preservative lubricating oil (special). If disassembly is undertaken, clean and oil all disassembled parts before assembling.

Caution: Do not dip the complete 20-mm feed mechanism AN-M2 or the driving mechanism assembly thereof in any cleaning fluid or oil, because this will destroy the lubricant in the unit. The driving

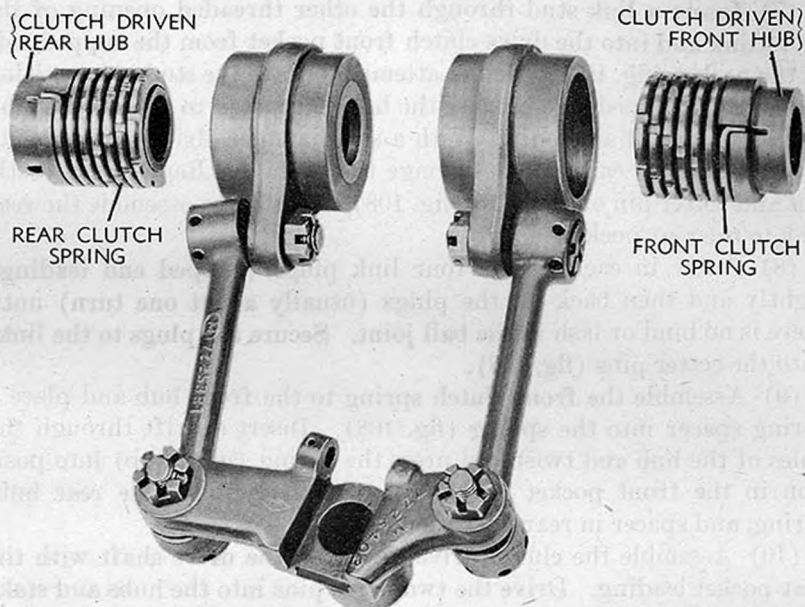

ASSEMBLING THE CLUTCH DRIVE GROUP FOR R.H. FEED MECHANISM

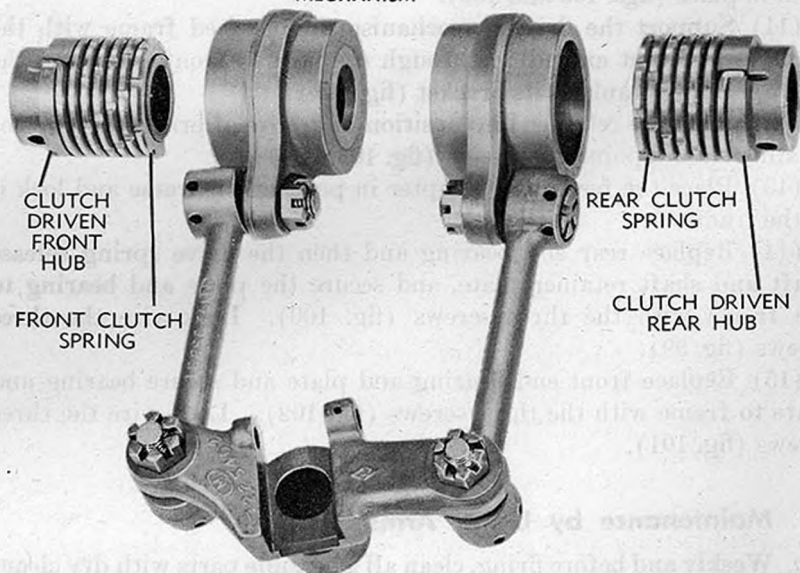

RA PD 94058

Figure 117. Assembling clutch drive groups for 20-mm right-hand and left-hand feed mechanisms AN-M2.

mechanism assembly is lubricated during manufacture and no provision is made for cleaning and lubricating after the assembly is riveted together.

b. Lubricate the following with a drop of oil:

- (1) Front holding cam.
- (2) Rear holding cam.
- (3) Cartridge control pawl.
- (4) Operating crank bracket.
- (5) Operating lever.
- (6) Joints of link assemblies.
- (7) Clutch driven hubs.

c. Examine the feed mouth for rough spots and remove any burrs from pins at front of mouth and from latch plate at rear of mouth. Do not remove metal from surfaces of feed mouth as cartridge control will be impaired by change of contour.

d. Remove any rough spots from star wheels. Do not disassemble the driving mechanism or dip it in any solvent or cleaning fluid.

e. Check for binding or backlash at ball joints between link studs and link stud plugs. Adjust plugs to eliminate binding or backlash.

f. Check the movement of the clutch drive. Disassemble and remove all rough spots from interior of clutch drive pockets.

g. Check whether cartridge guides, control pawl, and holding dog operate properly without binding. If they do not, disassemble, remove rough spots, and clean and oil.

h. Examine link chute for condition, and replace if broken or dented.

i. If the feed mechanism malfunctions, disassemble it and replace all worn, bent, or broken parts. (To replace driving mechanism assembly or clutch driven hubs, notify ordnance maintenance personnel.) If it still malfunctions, notify ordnance maintenance personnel.

82. Maintenance by Ordnance Maintenance Personnel

a. Perform maintenance operations given in paragraph 81 whenever necessary.

b. New driving mechanism assemblies do not have the outer pin hole drilled. New clutch hubs have only one side drilled. Therefore, use the one hole in the hub as a guide to drill through the shaft and on through the other side of the hub with a $\frac{3}{16}$ -inch drill. Have a piece of 0.003 shim stock between the inner faces of the clutch drive pockets before drilling, to allow 0.003 plus 0.002 clearance for satisfactory operation. Install and stake both ends of the pin in place (fig. 118). Install the winding nut over the mainshaft and secure with the rivet. Be sure this rivet is properly peened in place.

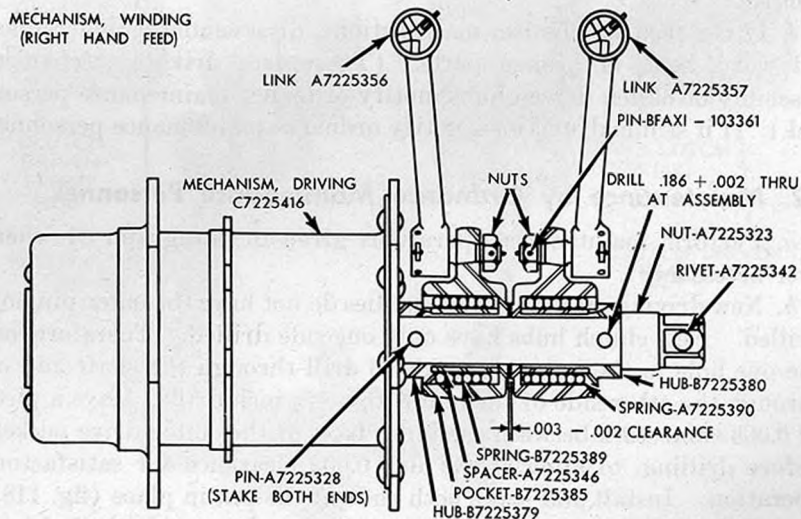
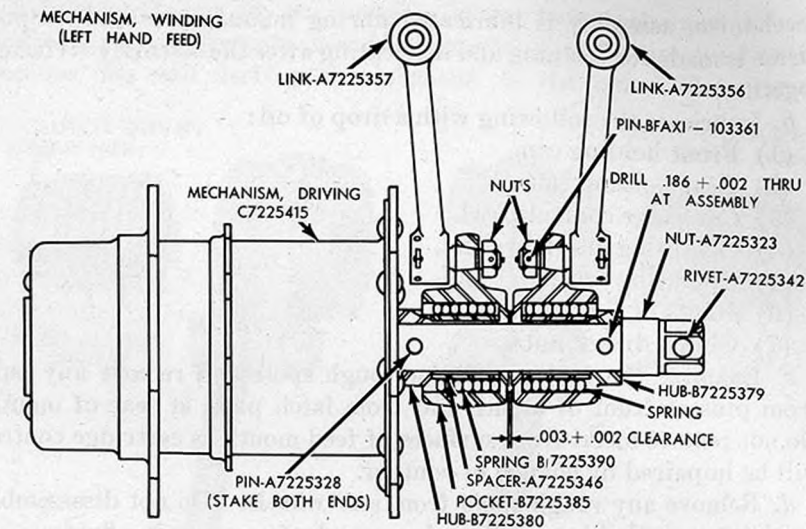

RA PD 91032

Figure 118. Assembling new driving mechanism assemblies of 20-mm right-hand and left-hand feed mechanisms AN-M2

Section XXIII. 20-MM FEED MECHANISM M3

83. General

a. The 20-mm feed mechanism M3 is an electrically operated device for feeding belted ammunition into the 20-mm automatic gun M3. The feed mechanism may be either right-hand or left-hand, depending on the way it is assembled (figs. 119, 120, 121, and 122).

b. The feeder will take belts made up of 20-mm belt links M3, M3A1, M7, and M8.

84. Functioning

a. **STRIPPING AND FEEDING OF ROUNDS (FIGS. 123 and 124).** (1) As the belt of ammunition is drawn in by the rotating feed wheels, the single end of the link, joining two rounds, is forced against the adjacent face of the stripper cover by the link stripper, which presses against the crimped portion of the link between the rounds. The link stripper thus provides a fulcrum about which the double end of the link is controlled to cause the stripper cover to force the link off of the round as the feed wheels continue to move the round downward.

(2) The freed link is guided into the link chute by the pressure of the link following and is disposed of by sliding out of the link chute.

(3) The freed round continues to move about the feed shaft, the inner faces of the chute supports controlling the round until it reaches the loading guides on the operating lever bracket.

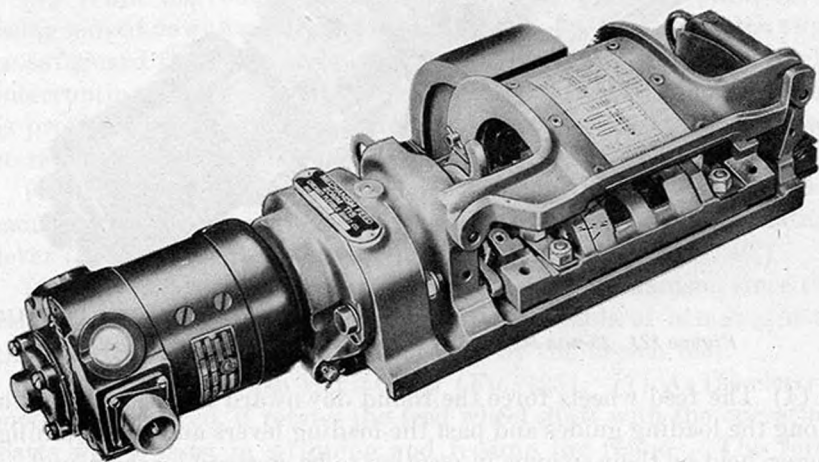
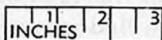

RA PD 94114

Figure 119. 20-mm right-hand feed mechanism M3—Right view.

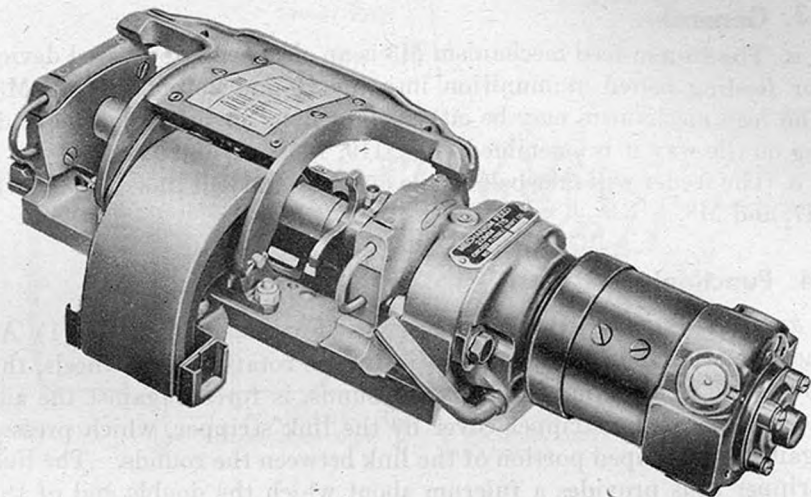

RA PD 94113

Figure 120. 20-mm right-hand feed mechanism M3—Left view.

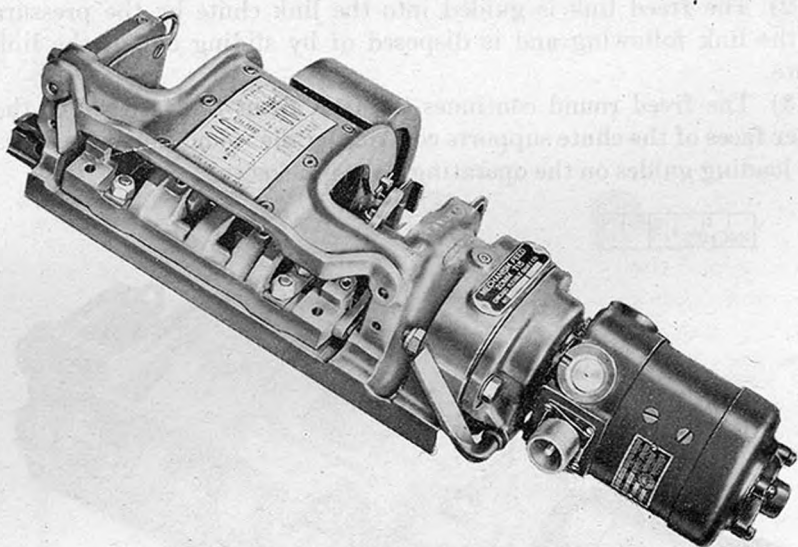

RA PD 94112

Figure 121. 20-mm left-hand feed mechanism M3—Right view.

(4) The feed wheels force the round downward in the feed mouth along the loading guides and past the loading levers and the retaining finger, held by their springs in position to be engaged by the round.

(5) As the round moves downward, the loading levers and the retaining finger are forced outward by the round; the springs, acting

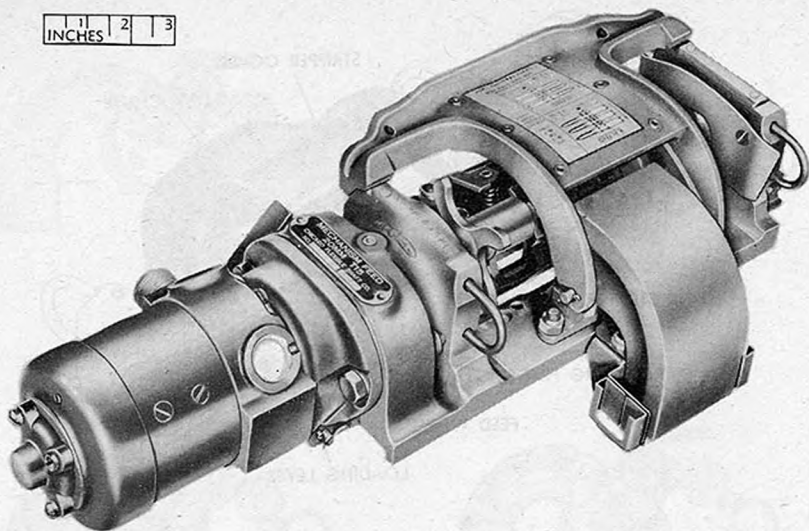

RA PD 94111

Figure 122. 20-mm left-hand feed mechanism M3—Left view.

on the loading levers and on the retaining finger, being energized by the yielding movement of these parts.

(6) When the round reaches a position in the feed mouth in which it is beyond the control of the feed wheels, that is, in which it has moved beyond the periphery of the feed wheels, the loading levers are free to return to their initial position in the feed mouth and, in so doing, snap the round downward by the action of their springs as soon as the bolt moves to the rear.

(7) While the round is held in the feed mouth in preparation to being moved downward by the loading levers, the friction clutch slips to safeguard the motor against excessive pressure, thus temporarily interrupting the rotation of the feed wheel shaft until sufficient room is provided by the final down feed movement of the leading round to resume the functioning of the feeder.

(8) The round is held in final position on the ways of the feed mouth at the proper angle by the retaining finger and the rear loading lever (fig. 124) for ramming by the breechblock. (See par. 49.)

(9) The last round may be fed from the feed mechanism, since the retaining finger and the loading levers are capable of bringing it to the position from which it is picked up by the breech bolt.

b. OPERATION OF FEED MECHANISM (FIG. 125). (1) As the electric motor is energized, it rotates the feed wheel shaft with the operating parts which assist in stripping and feeding the rounds. The force from the motor to the shaft is transmitted through a planet gear unit and a friction clutch.

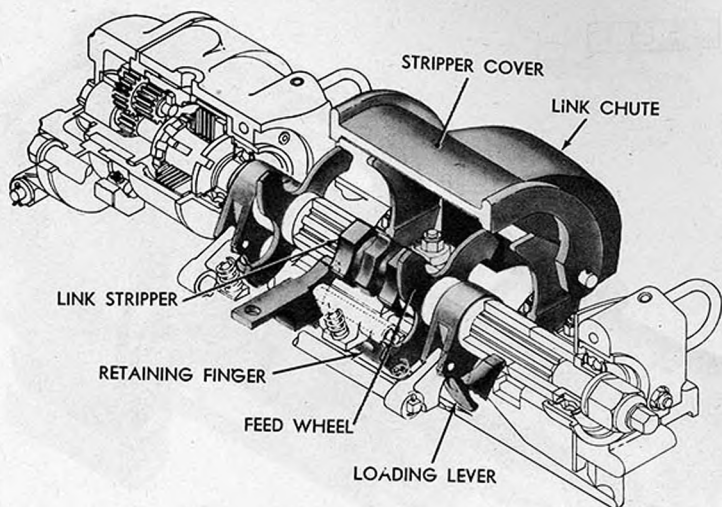

A

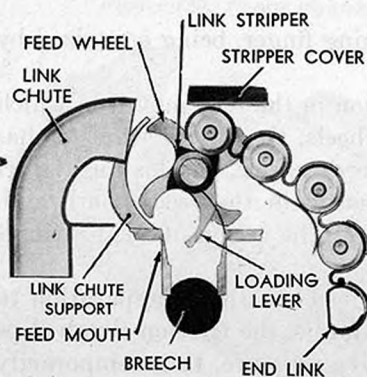

B

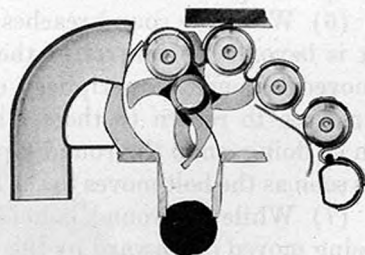

C

RA PD 94116

Figure 123. Travel of rounds through 20-mm feed mechanism M3.

(2) The planet gear unit functions as a reduction gear, transmitting one rotation to the feed wheel shaft for each 35.7 rotations of the motor. The motor rotates a gear shaft which, in turn, rotates planet pinions. The pinions rotate a clutch gear to which the driving members (friction washers) of the friction clutch are joined. The driven members (friction disks) of the friction clutch are mounted to rotate with the feed wheel shaft.

(3) Since the feed wheel shaft cannot feed faster than the rate of fire of the gun, the friction clutch slips a little before each round is

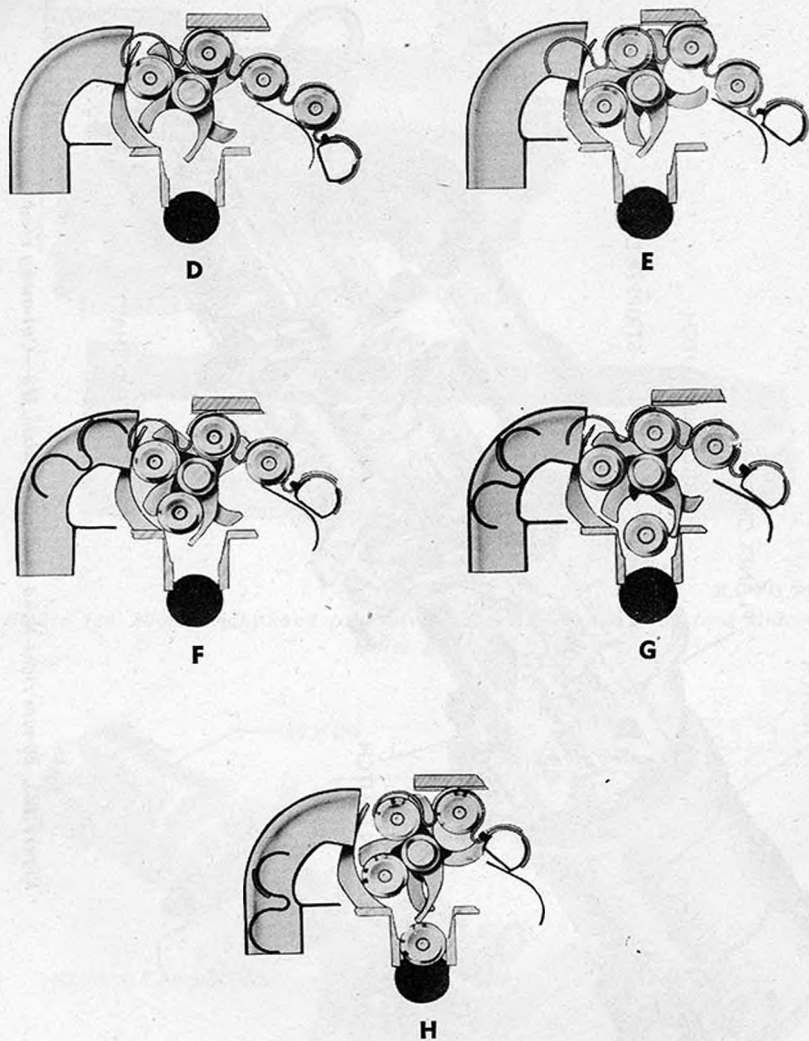

RA PD 94117

Figure 124. Travel of rounds through 20-mm feed mechanism MS.

removed from the feed mouth by the breechblock. The clutch is normally set to transmit a torque of from 160 to 170 pound-inches at motor speed before slipping. The setting of the clutch is determined by a lock nut threaded on the end of the shaft.

(4) A Horton clutch prevents reverse movement of the rounds when the gun is not being fired, if the reverse torque is less than the friction clutch setting.

Figure 125. 20-mm right-hand feed mechanism M3—Cut-away view.

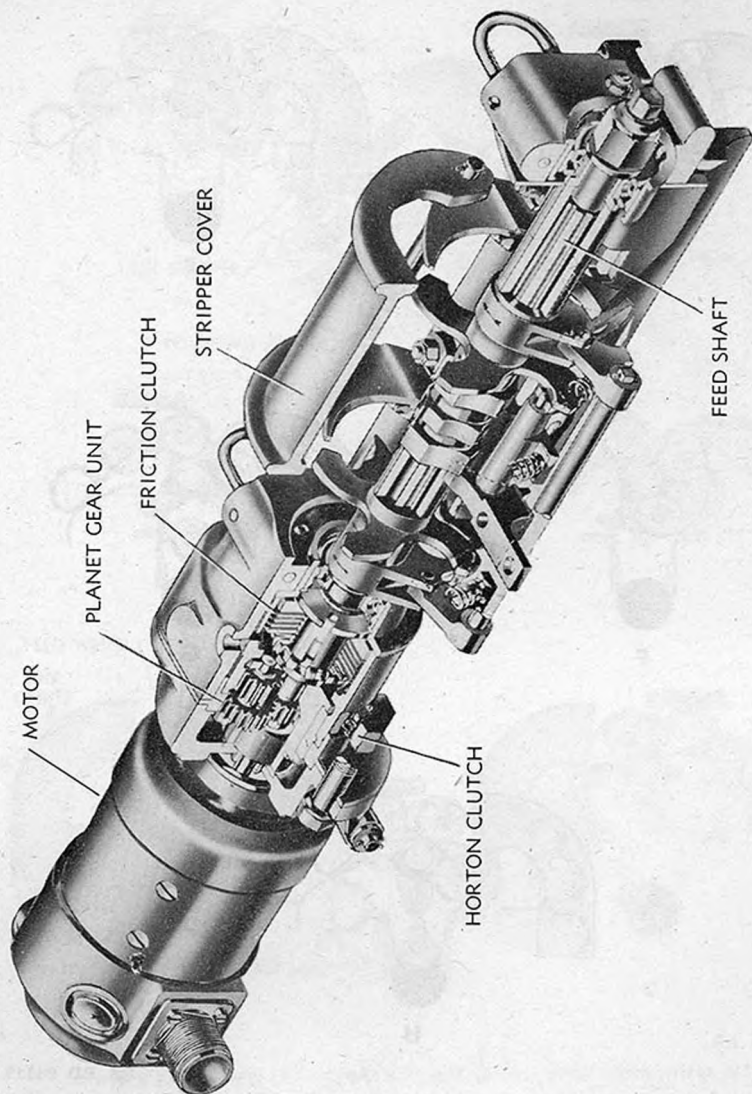

85. Disassembly

Note. The feed mechanism must be unloaded and removed from the gun before it is to be disassembled.

a. REMOVAL OF FEED SLIDE AND MOTOR GROUP. (1) Rotate slide latch lever (fig. 126) and remove the feed slide (fig. 126).

(2) Unscrew the two nuts from the housing cap screws (fig. 126) and pull the motor off the feed frame group. Remove the planet gear unit from motor group (fig. 127).

b. EJECTOR GROUP. (1) Withdraw the slide latch (fig. 128).

(2) Withdraw the two ejector springs (fig. 128).

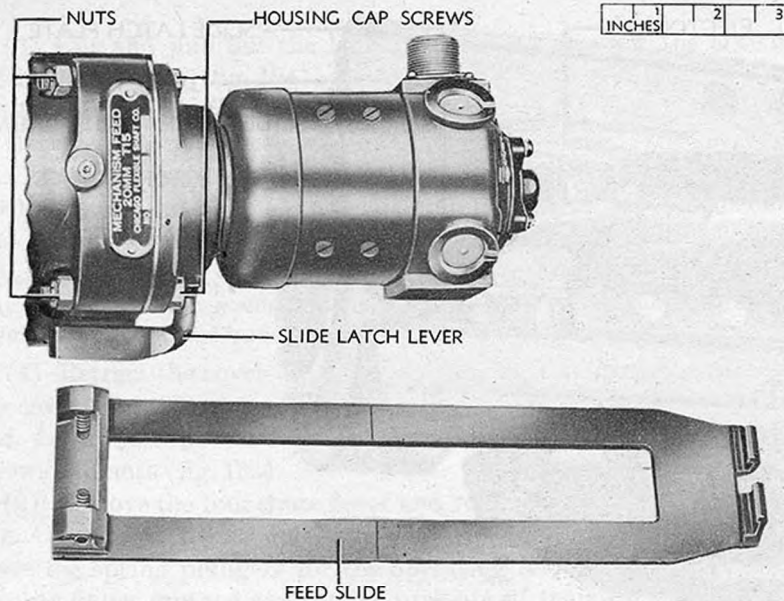

RA PD 94110

Figure 126. 20-mm right-hand feed mechanism M3—Removal of feed slide and motor group.

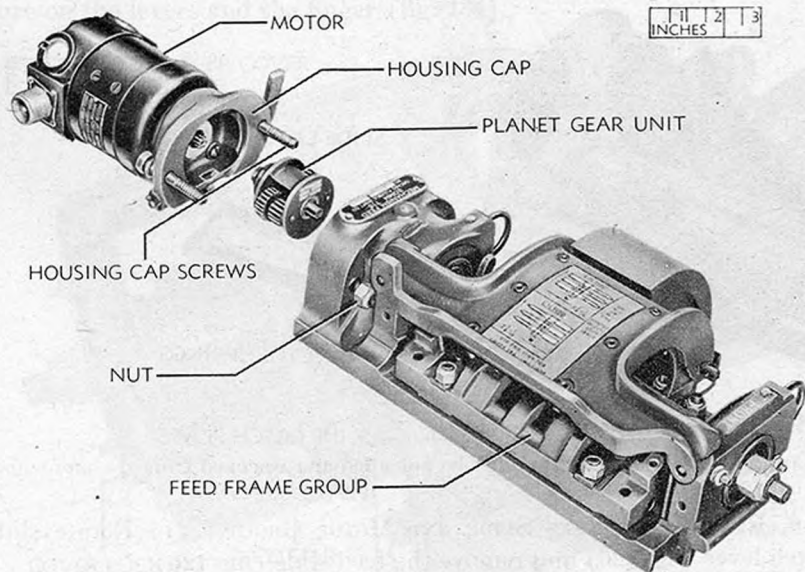

RA PD 94109

Figure 127. 20-mm right-hand feed mechanism M3—Motor, planet gear unit, and feed frame group.

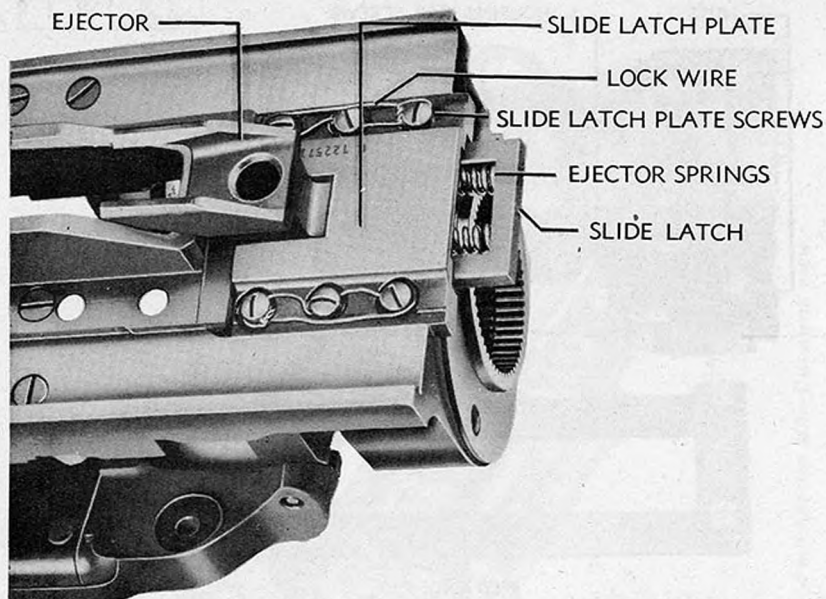

RA PD 94108

Figure 128. 20-mm feed mechanism M3—Disassembly of ejector group.

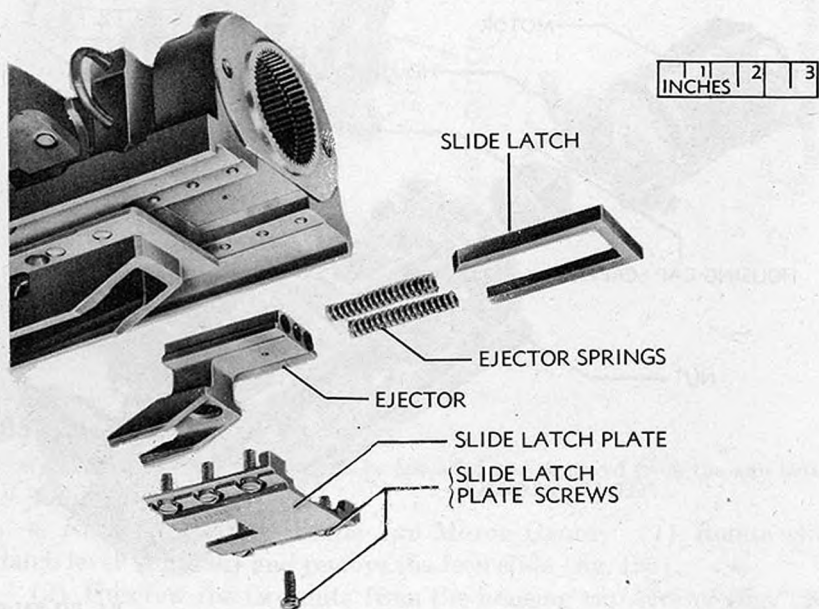

RA PD 94107

Figure 129. 20-mm feed mechanism M3—Parts of ejector group.

(3) Cut and pull out the locking wire and unscrew the six slide latch plate screws (fig. 124).

(4) Remove the slide latch plate and the ejector (fig. 128). Parts of the ejector group are shown in figure 129.

c. LINK CHUTE AND STRIPPER COVER. (1) Remove the cotter pins from the link chute and stripper cover pin (fig. 130). Pull out the link chute and stripper cover pin (fig. 130). Remove the link chute (fig. 130).

Note. Instead of the bottom disposal link chute (fig. 130), the feed mechanism may be equipped with a side disposal link chute (fig. 131). However, the procedures for removal and installation are identical.

(2) Retract the cover locking pins (fig. 130) and remove the stripper cover (fig. 130).

d. LINK CHUTE SUPPORTS. (1) Unscrew the link chute support screws and nuts (fig. 132).

(2) Remove the link chute front and rear supports (fig. 133).

e. OPERATING LEVER BRACKET GROUP. (1) In successive order, press the spring plungers for the operating levers and the round retaining finger upward against the pressure of their springs by means of a screwdriver until the plungers project beyond the top of the bracket pins (fig. 134). Lock the plungers in this position by entering a thin wire, or the like, through the hole in the top of each plunger, locking the plungers in raised position and relieving the spring pressure on the levers and the finger (fig. 134).

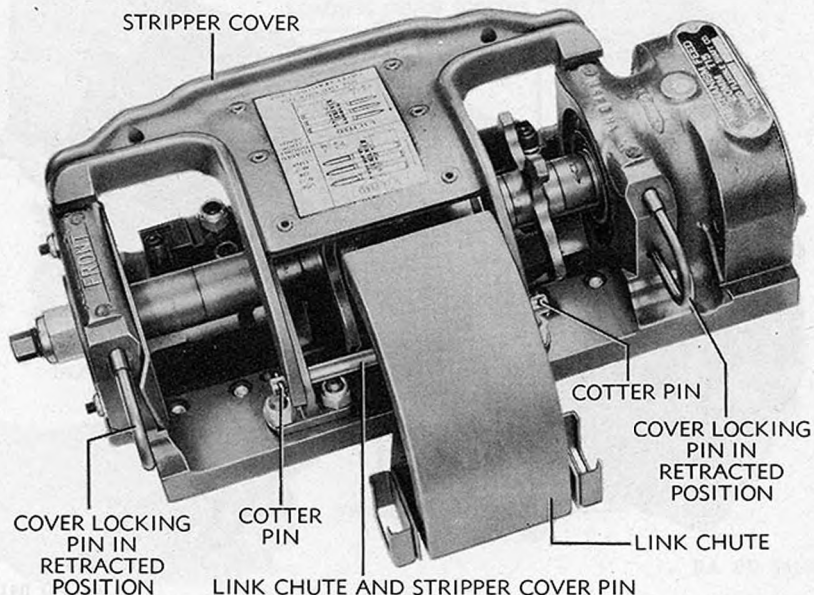

RA PD 94106

Figure 130. 20-mm feed mechanism M3—Removal of link chute and stripper cover.

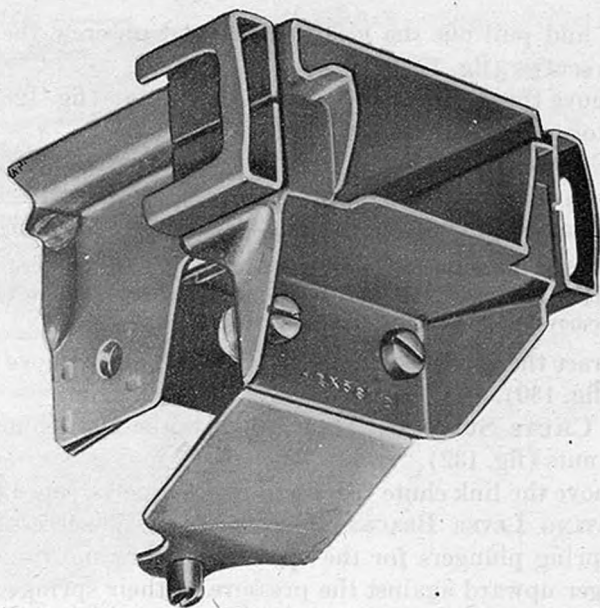

RA PD 94003

Figure 131. 20-mm feed mechanism M3—Side disposal link chute.

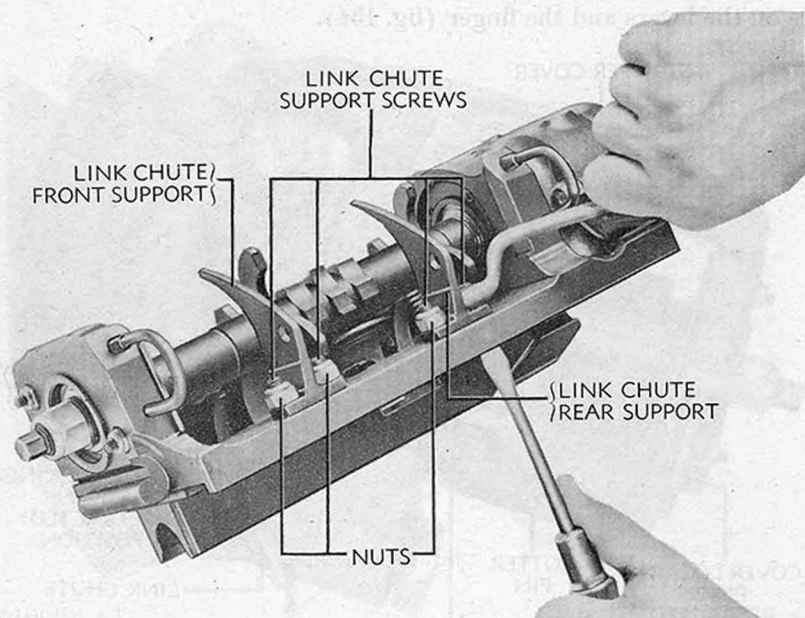

RA PD 94105

Figure 132. 20-mm right-hand feed mechanism M3—Removal of link chute supports.

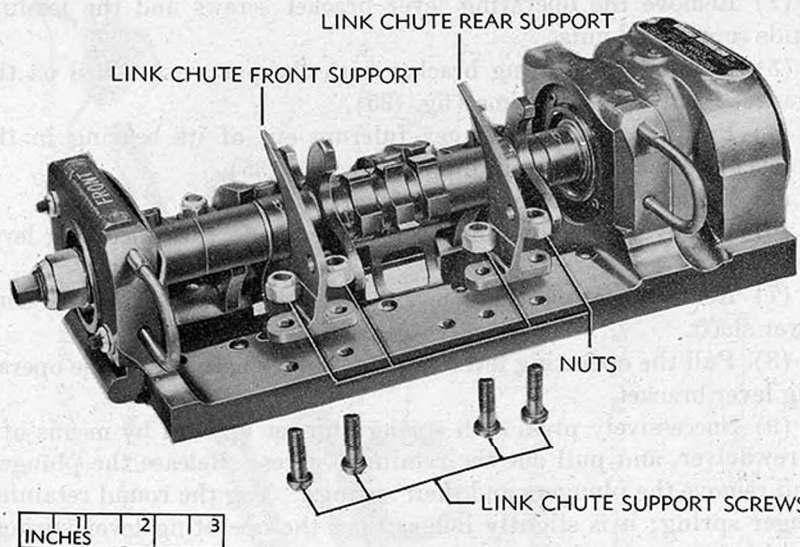

RA PD 94104

Figure 133. 20-mm right-hand feed mechanism M3—Parts of link chute support group.

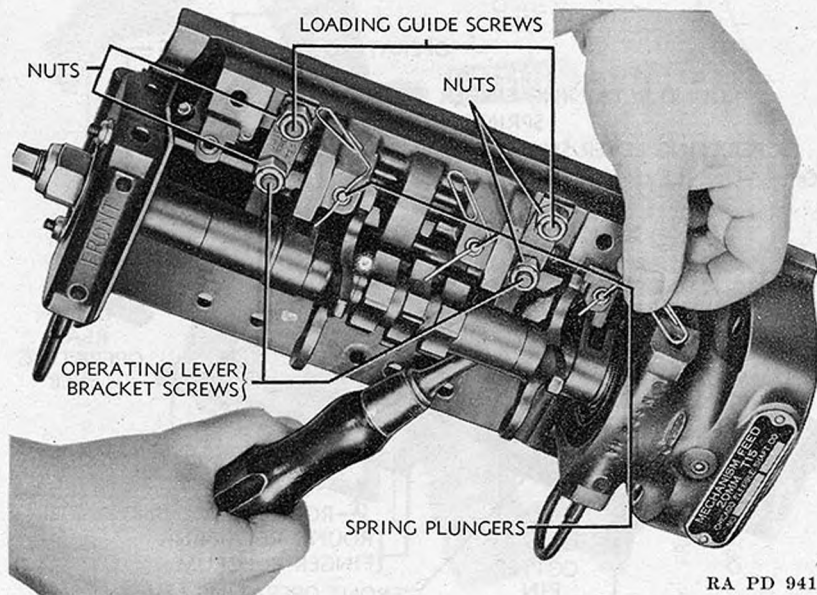

RA PD 94103

Figure 134. 20-mm right-hand feed mechanism M3—Removal of operating lever bracket group.

(2) Remove the operating lever bracket screws and the loading guide screws and nuts.

(3) Remove the loading bracket with the parts assembled on the bracket from the feed frame (fig. 135).

(4) Pull the retaining finger fulcrum out of its bearing in the bracket and remove the retaining finger (fig. 135).

(5) Remove the loading guides from the bracket.

(6) Remove the cotter pins from the ends of the operating lever shaft.

(7) Remove the operating levers from the ends of the operating lever shaft.

(8) Pull the operating lever shaft out of its bearings in the operating lever bracket.

(9) Successively press each spring plunger upward by means of a screwdriver, and pull out the retaining wires. Release the plungers and remove the plungers and their springs. Tag the round retaining finger spring; it is slightly longer than the operating lever springs. Parts of operating lever bracket group are shown in figure 136.

f. CLUTCH GEAR GROUP. (1) Pull the internal gear off the feed frame.

(2) Screw the clutch puller screw (Federal Stock No. 41-S-1026-700) (fig. 28) into one of the clutch plates and pull the plate out of the gear housing (fig. 137). Similarly, remove the second plate.

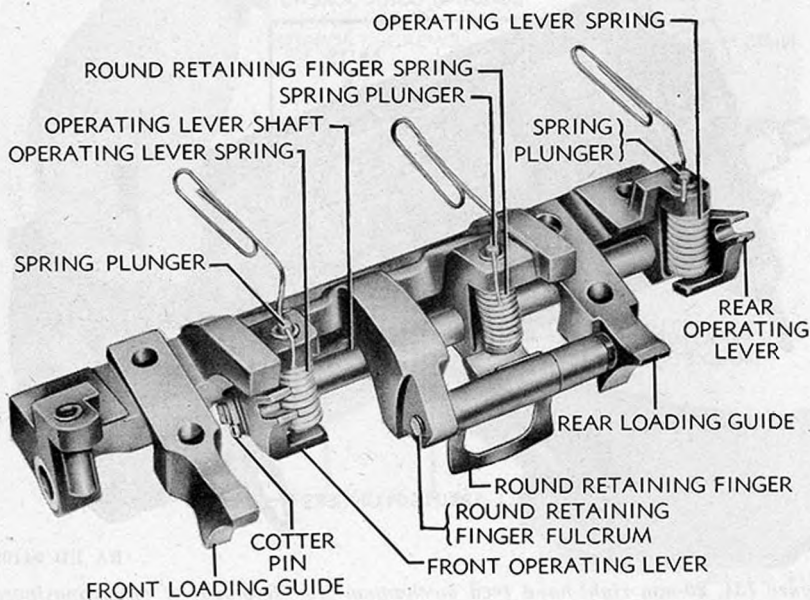

RA PD 94102

Figure 135. 20-mm right-hand feed mechanism M3—Operating lever bracket group.

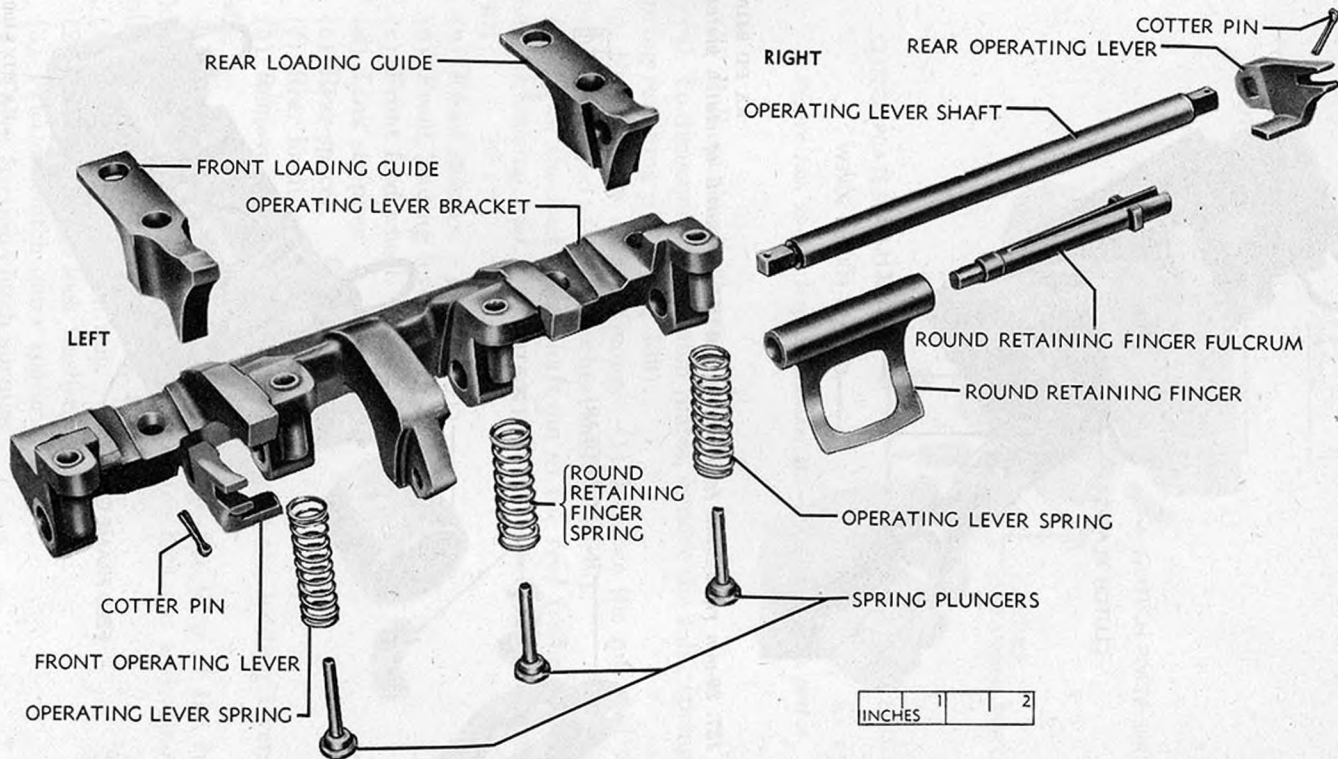
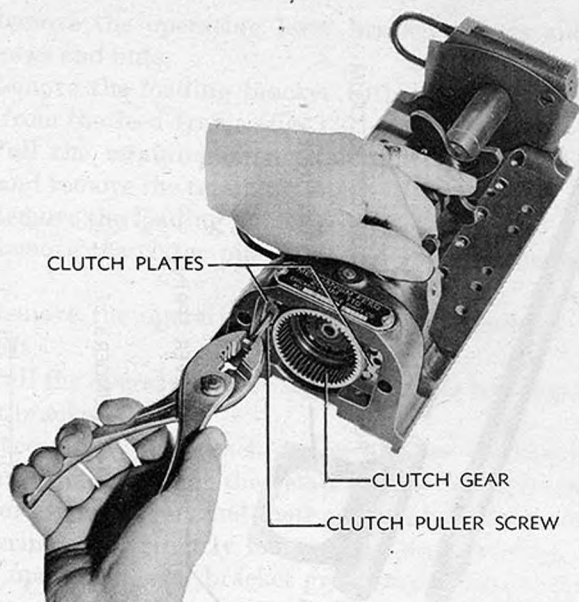

Figure 136. 20-mm right-hand feed mechanism M3—Parts of operating lever bracket group.

RA PD 94101



RA PD 94100

Figure 137. 20-mm right-hand feed mechanism M3—Removal of clutch plates.

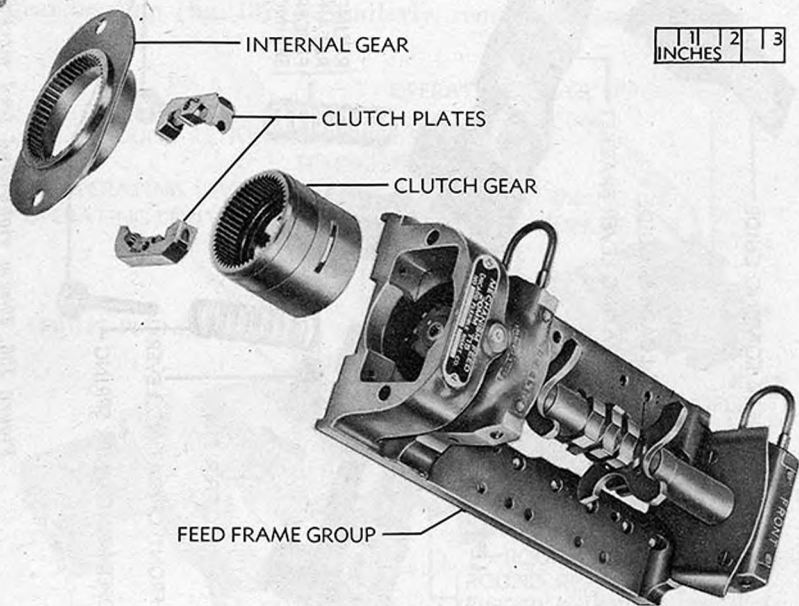

RA PD 94099

Figure 138. 20-mm right-hand feed mechanism M3—Internal gear, clutch plates, clutch gear, and feed frame group.

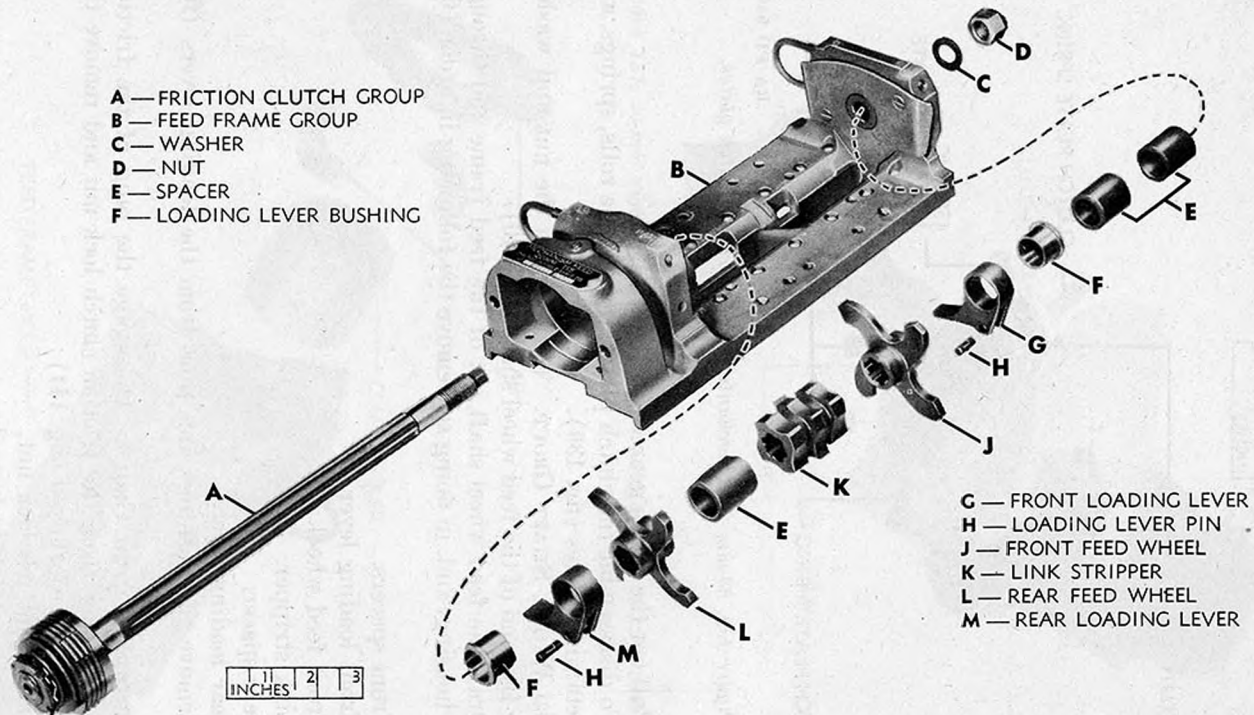

RA PD 94097

Figure 140. 20-mm right-hand feed mechanism M3—Parts of feed wheel shaft group.

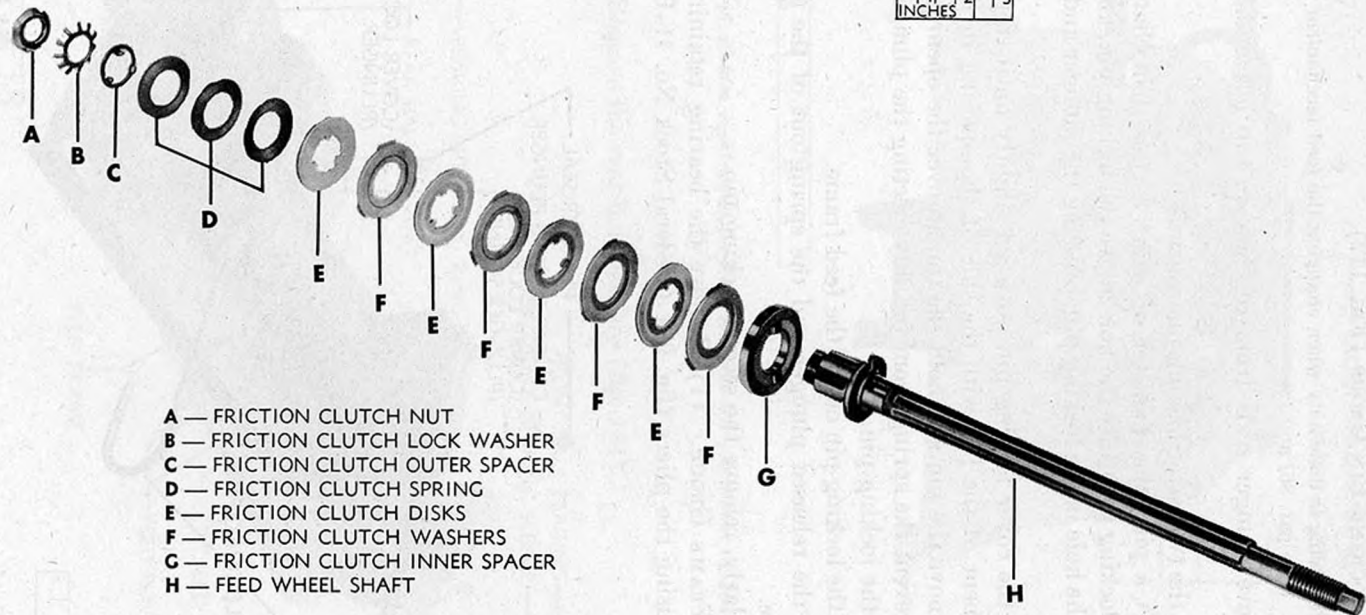

Figure 141. 20-mm feed mechanism M3—Parts of friction clutch group.

RA PD 94096

i. COVER LOCKING PIN GROUP (FIG. 142).

Note. The following is done only when changing the feed mechanism to either right or left. (See par. 86j and k.)

(1) Remove plunger seals from the hole in top left end of feed frame.

(2) Pull the two cover locking pins outward.

(3) Insert a pin (the diameter of which is less than that of the hole in the locking pin) into the hole above the locking pin, and enter it through the hole in the locking pin, pressing the plunger and spring downward.

(4) Pull the cover locking pin outward slightly until stopped by the engagement of the pin with the side of the opening in the feed frame. Remove the pin and hold the thumb over the opening in the frame to prevent the spring from forcibly ejecting the plunger when released by the locking pin.

(5) Pull the locking pin out of the feed frame.

(6) Pull the released plunger and the spring out of the opening in the frame.

(7) Similarly, remove the second locking pin.

j. FEED FRAME GROUP. (1) Remove the bearing retaining ring (fig. 143), using the pliers (fig. 28) (Federal Stock No. 41-P-1992-35).

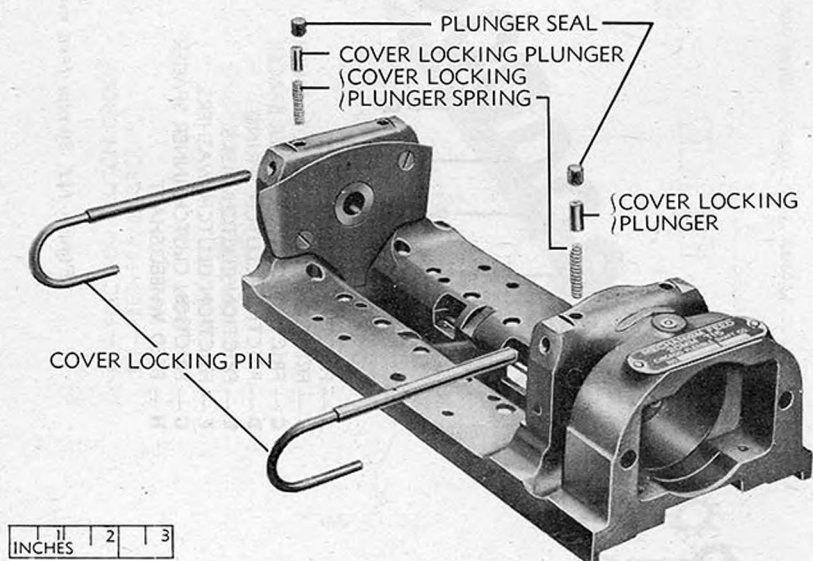

RA PD 94095

Figure 142. 20-mm right-hand feed mechanism M3—Parts of cover locking pin group.

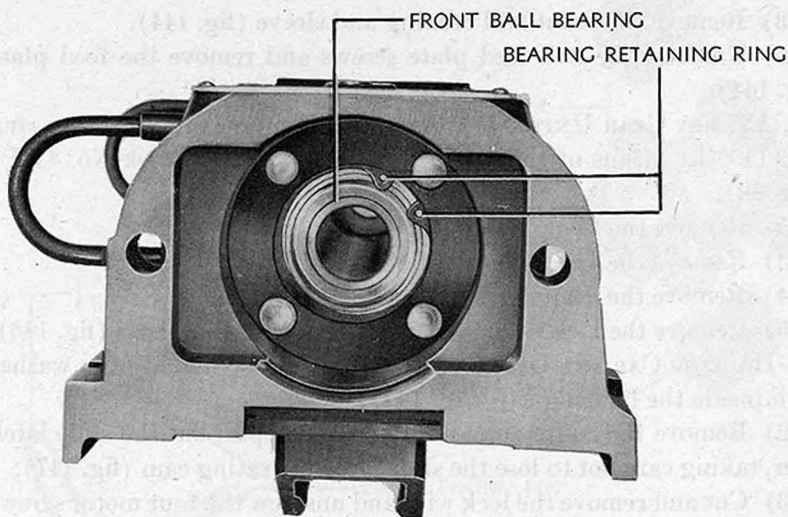

RA PD 94094

Figure 143. 20-mm right-hand feed mechanism M3—Removal of bearing retaining ring.

(2) Remove the rear ball bearing (fig. 144).

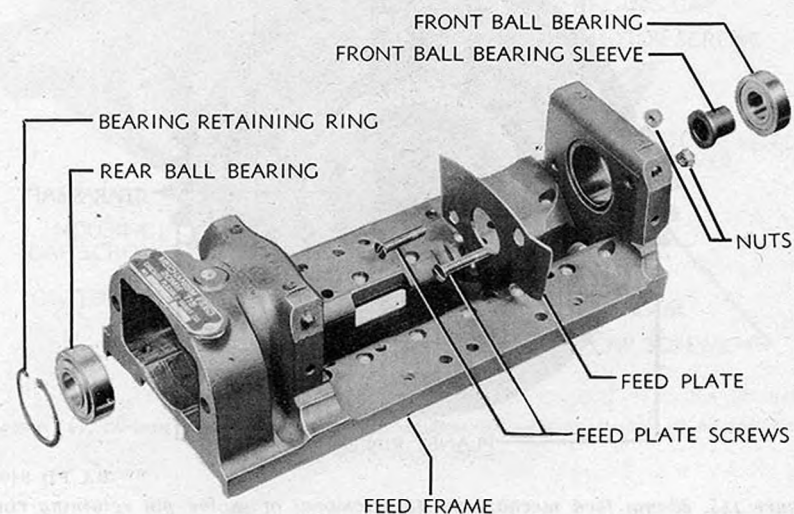

RA PD 94098

Figure 144. 20-mm feed mechanism M3—Feed frame group.

- (3) Remove the front ball bearing and sleeve (fig. 144).
- (4) Unscrew the two feed plate screws and remove the feed plate (fig. 144).

k. PLANET GEAR UNIT. (1) Remove the pinion pin retaining ring (fig. 145) by means of the pliers (fig. 28) (Federal Stock No. 41-P-1992-28).

(2) Remove the two planet pinion pins (fig. 145).

(3) Remove the two planet pinions (fig. 146).

(4) Remove the gear shaft (fig. 146).

(5) Remove the lock ring and spacer from the gear shaft (fig. 146).

l. HOUSING CAP AND LATCH LEVER GROUP. (1) Remove the washer from inside the housing cap (fig. 147).

(2) Remove the cotter pin and washer, and pull out the slide latch lever, taking care not to lose the slide latch operating cam (fig. 147).

(3) Cut and remove the lock wire and unscrew the four motor screws (fig. 147). Remove four washers.

(4) Parts of the housing cap and latch lever group are shown in figure 148.

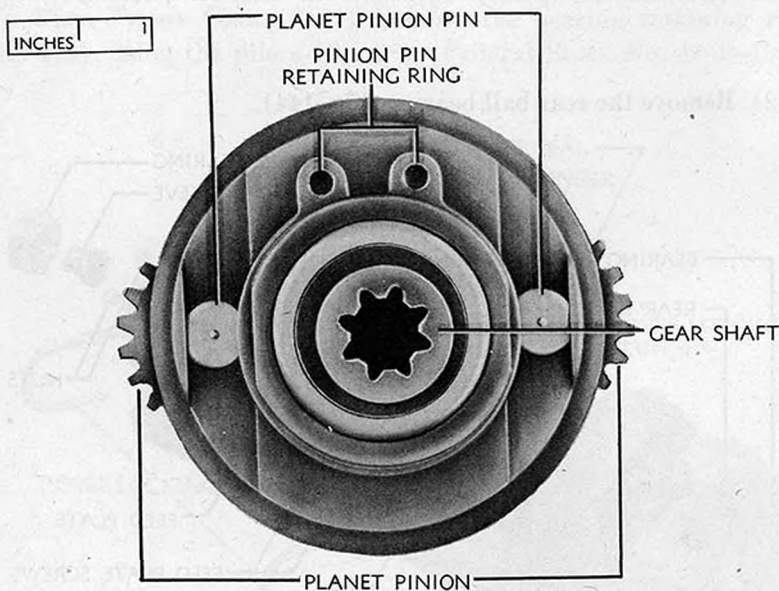

RA PD 94092

Figure 145. 20-mm feed mechanism M3—Removal of pinion pin retaining ring.

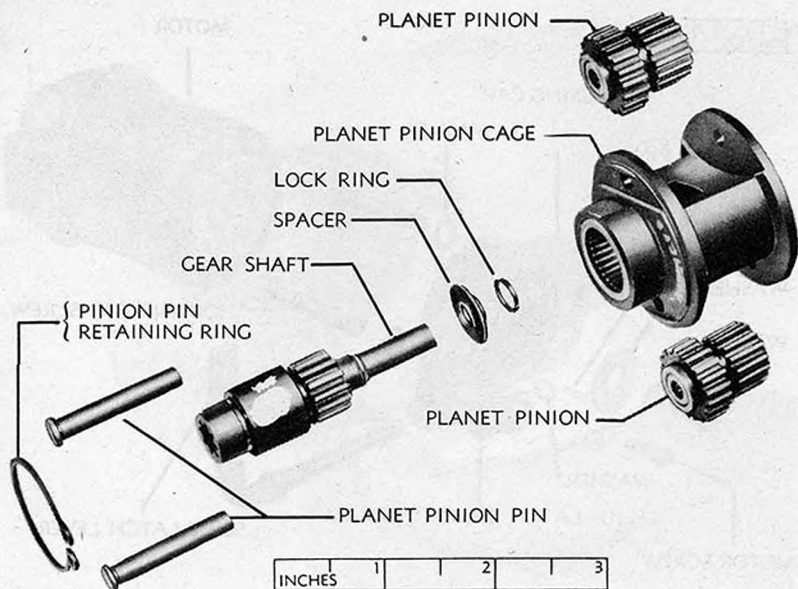

RA PD 94091

Figure 146. 20-mm feed mechanism M3—Parts of planet gear unit.

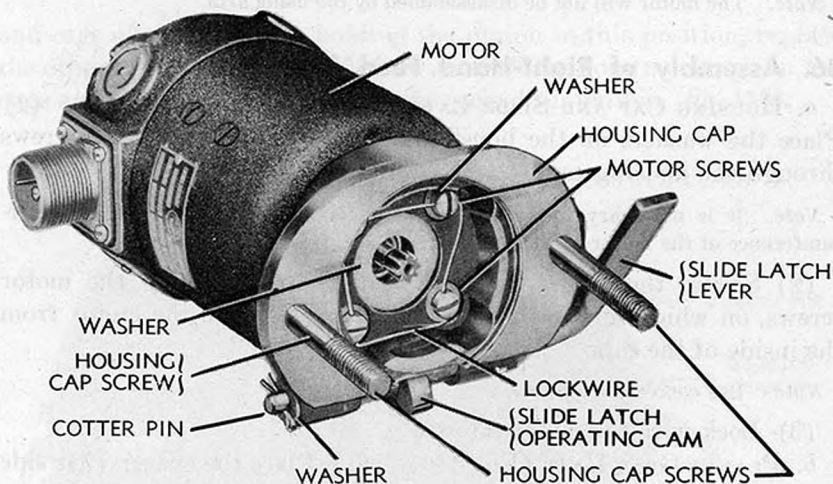

RA PD 94090

Figure 147. 20-mm right-hand feed mechanism M3—Disassembly of housing cap and latch lever group.

1	2	3
INCHES		

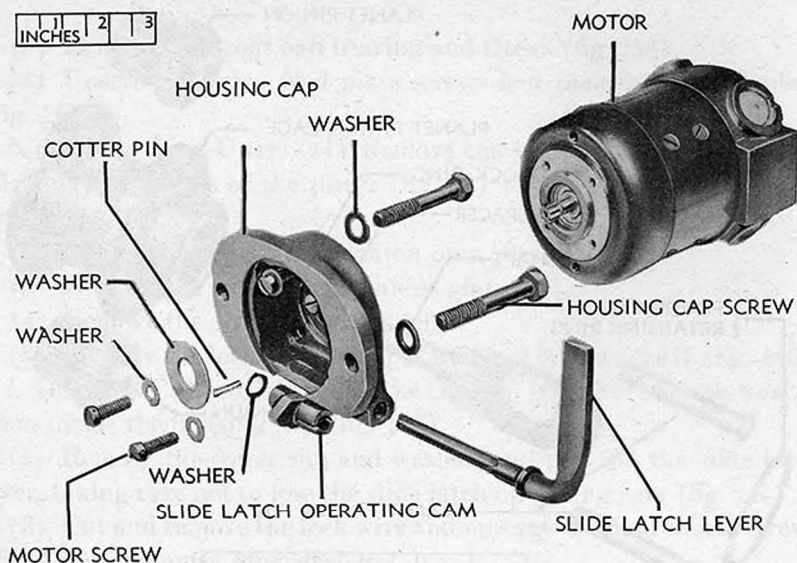

RA PD 94089

Figure 148. 20-mm right-hand feed mechanism M3—Parts of housing cap and latch lever group.

Note. The motor will not be disassembled by the using arm.

86. Assembly of Right-Hand Feed Mechanism

a. HOUSING CAP AND SLIDE LATCH LEVER GROUP (FIG. 147). (1) Place the washers on the housing cap screws and insert the screws through the housing cap.

Note. It is necessary to do this before attaching the motor, since the circumference of the motor exceeds that of the cap.

(2) Secure the motor to the housing cap, threading the motor screws, on which the washers have been placed, into the motor from the inside of the cap.

Note. Use correct motor end.

(3) Lock-wire the motor screws.

b. PLANET GEAR UNIT (FIG. 146). (1) Place the spacer (flat side leading) onto the gear shaft and secure by means of the lock ring.

(2) Insert the gear shaft into the planet pinion cage.

(3) Place one pinion in one opening of the cage with the bearings in alignment with the holes in the cage, making certain that the larger pinion is at the side of the cage provided with a hub.

(4) Secure the pinion by inserting the pinion pin from the side of the cage closest to the larger pinion. The flat end on the head of the pin should point toward periphery of cage (fig. 149).

(5) Rotate the assembled pinion until the markings on the pinion

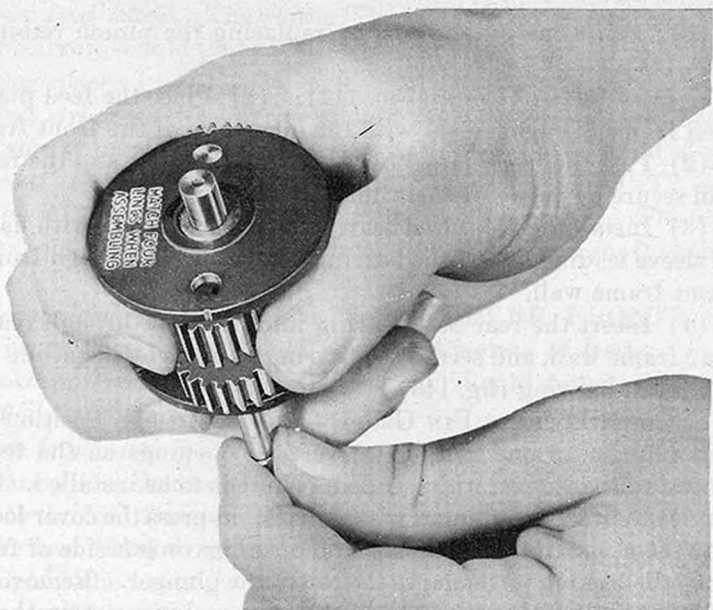
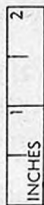

RA PD 94086

Figure 149. 20-mm feed mechanism M3—Replacing planet pinions.

and cage align and, while holding the pinion in this position, replace the other pinion and manipulate it until all the four markings on the cage and pinions align. Replace the second pinion pin (fig. 150).

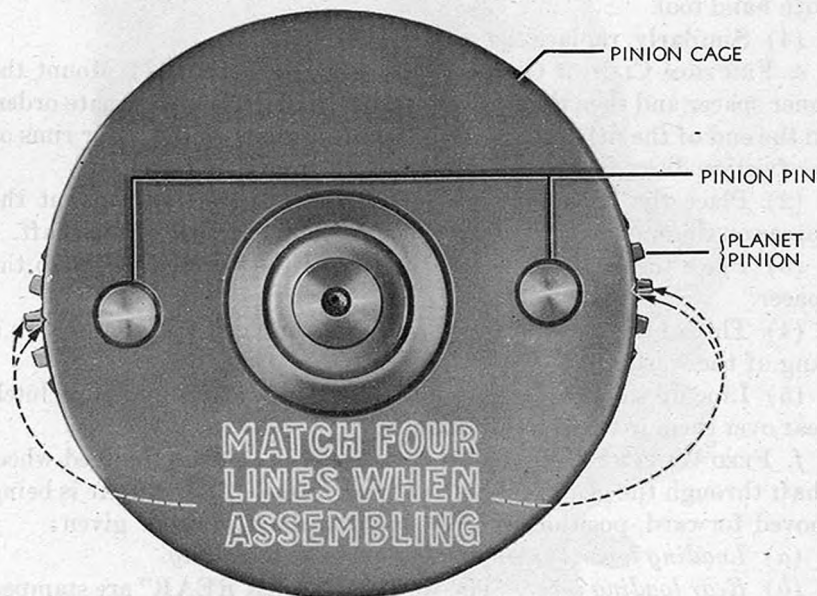

RA PD 94087

Figure 150. 20-mm feed mechanism M3—Planet pinions in correct alignment.

(6) Secure the pinion pins by replacing the pinion retaining ring (fig. 145).

c. FEED FRAME GROUP (FIG. 144). (1) Place the feed plate on the feed frame in engagement with the inner face of the front frame wall.

(2) Pass the feed plate screws through the plate and the feed frame and secure by means of their nuts.

(3) Install the front ball bearing on its sleeve and, with flanged end of sleeve leading, insert the bearing into position through front face of front frame wall.

(4) Insert the rear ball bearing into position through rear face of rear frame wall, and secure the bearing in place by installing the bearing retaining ring (fig. 143).

d. COVER LOCKING PIN GROUP (FIG. 142). (1) Position a spring and plunger in one of the two vertical openings on the feed frame closest to the side on which the link chute is to be installed.

(2) Depress the plunger with a drift and press the cover locking pin into the upper of the two horizontal openings on left side of feed frame until the locking pin engages the top of the plunger. Remove the drift and press the locking pin in all the way, making certain that shorter arm of the locking pin fits into the lower of the two horizontal openings on the left side of the feed frame (fig. 142).

(3) Replace the plunger seal. The use of the tool shown in figure 36 will greatly aid in installing the seal. Place funnel shaped piece in plunger hole, position seal in this piece and push it down into position with hand tool.

(4) Similarly, replace the second locking pin.

e. FRICTION CLUTCH GROUP (FIGS. 140 AND 141). (1) Mount the inner spacer and then the friction washers and disks in alternate order, on the end of the drive shaft, with the projections on the inner rims of the friction disks engaging corresponding grooves in the shaft.

(2) Place the three springs on the outer spacer, and mount the spacer on the end of the feed shaft engaging in a groove of the shaft.

(3) Place the lock washer on the end of the shaft adjacent to the spacer.

(4) Thread the lock nut onto the end of the shaft and secure with a tang of the washer.

(5) Line up the projections on the friction washers and slip clutch gear over them to check their alinement.

f. FEED WHEEL SHAFT GROUP (FIG. 140). (1) Pass the feed wheel shaft through the gear housing and feed frame. As the shaft is being moved forward, position the following on shaft in order given:

(a) *Loading lever bushing with flanged end leading.*

(b) *Rear loading lever.* The words "LEVER REAR" are stamped on it. The arrow stamped on lever should point in direction of feed. Make certain lever fits completely on lever bushing.

(c) *Rear feed wheel.* The words "WHEEL REAR" are stamped on it. The arrow should point in direction of feed.

(d) *Rear spacer.*

(e) *Link stripper.* The arrow should point in direction of feed. The "O" marks on stripper, rear feed wheel, and shaft should aline.

(f) *Front feed wheel.* The words "WHEEL FRONT" are stamped on it. The arrow should point in direction of feed. The "O" marks on front feed wheel, stripper, rear feed wheel, and shaft should aline.

(g) *Front loading lever.* The words "LEVER FRONT" are stamped on it. The arrow should point in direction of feed.

(h) *Loading lever bushing.* Flanged end should follow; bushing should fit in completely in lever.

(i) *Two front spacers.*

(2) Place the washer on the free front end of the feed wheel shaft adjacent to the feed frame, and thread the nut on the end of the shaft to lock the feed wheel drive parts in place on the feed wheel shaft.

(3) Replace the loading lever pins in the loading levers.

g. CLUTCH GEAR GROUP (FIGS. 138 AND 139). (1) Replace the clutch in the gear housing so that the projections on the friction washers engage the corresponding grooves in the clutch gear.

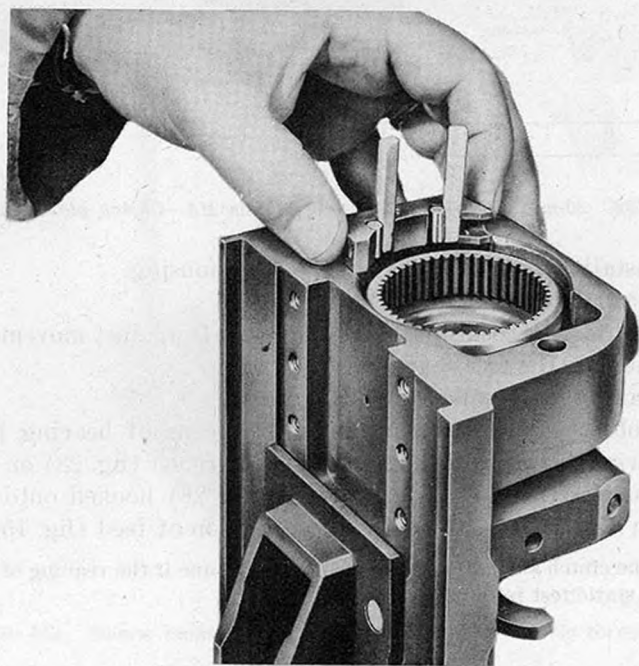

RA PD 94085

Figure 151. 20-mm feed mechanism M3—Installing clutch plate.

(2) Install the clutch plate springs and rolls in the clutch plates (fig. 139).

(3) Compress the clutch plate springs by inserting a block of wood between the roll and its bearing (fig. 151) and replace the plate in the gear bushing (fig. 151). Mounting is facilitated by pushing the clutch gear toward the installed clutch plate and simultaneously rotating it in direction of feed. The arrow on the plate should point in direction of shaft rotation. Figure 152 shows correct installation of plates for a right-hand feed mechanism.

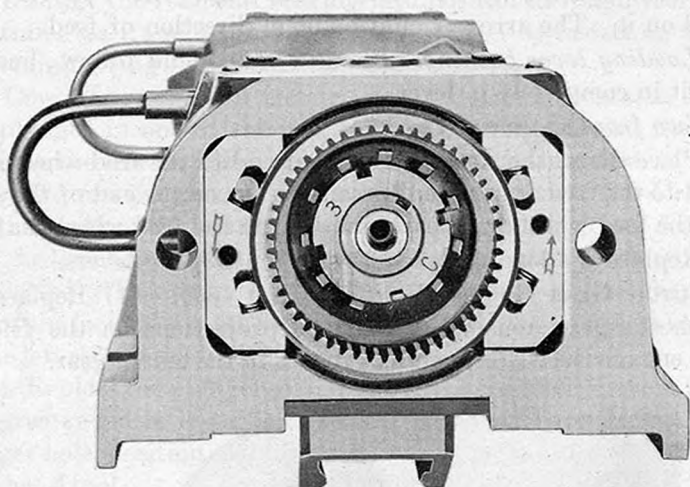

RA PD 94084

Figure 152. 20-mm right-hand feed mechanism M3—Clutch plates installed.

(4) Install the internal gear in the gear housing.

(5) Place the feed mouth in a vise.

(6) Tighten the lock nut, holding the shaft against movement by a bar mounted on the free shaft end (fig. 153).

(7) Make static torque test as follows:

(a) Hold the lock nut stationary by means of bearing lock nut spanner wrench (fig. 28) and mount a bar wrench (fig. 28) on the free end of the shaft. Pull a spring scale (fig. 28) hooked onto the bar wrench in a direction opposite to the direction of feed (fig. 154).

Note. The clutch should transmit the desired torque if the reading of the scale during the static test is 20 pounds.

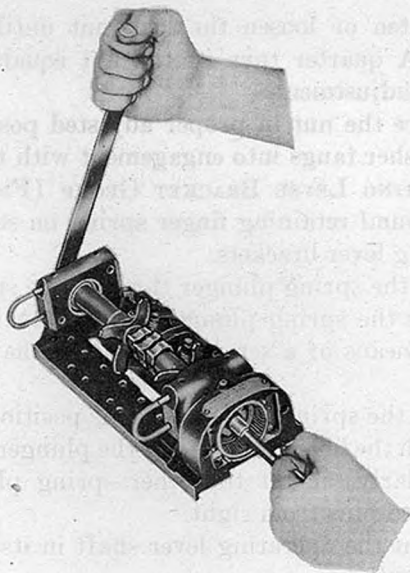

RA PD 94082

Figure 153. 20-mm right-hand feed mechanism M3—Tightening clutch nut.

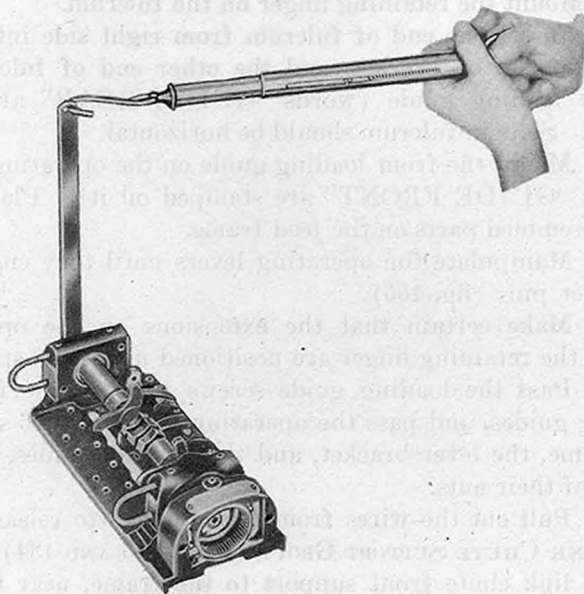

RA PD 94081

Figure 154. 20-mm right-hand feed mechanism M3—Static torque test.

(b) Tighten or loosen the lock nut until the desired setting is obtained. A quarter turn of the nut equals, approximately, a 25-pound-inch adjustment.

(c) Secure the nut in proper adjusted position by moving one of the lock washer tangs into engagement with the adjacent nut groove.

h. OPERATING LEVER BRACKET GROUP (FIGS. 136 AND 137). (1) Place the round retaining finger spring on second pin from right of the operating lever brackets.

(2) Pass the spring plunger through the spring and the pin.

(3) Press the spring plunger upward against the pressure of the spring, by means of a screwdriver, until the plunger projects above bracket.

(4) Lock the spring plunger in this position by inserting a locking wire through the hole in the end of the plunger.

(5) Similarly, mount the other spring plungers and springs on first and third pins from right.

(6) Mount the operating lever shaft in its bearings in the operating lever bracket.

(7) Place the operating levers on the ends of the operating lever shaft. Splines on levers and shaft should aline.

(8) Secure levers to shaft with cotter pins.

(9) Mount the retaining finger on the fulcrum.

(10) Insert one end of fulcrum from right side into hole in central extension on bracket, and the other end of fulcrum into hole in rear loading guide (words "GUIDE REAR" are stamped on guide). Slots in fulcrum should be horizontal.

(11) Mount the front loading guide on the operating lever bracket (words "GUIDE FRONT" are stamped on it). Place the bracket with assembled parts on the feed frame.

(12) Manipulate the operating levers until they engage the loading lever pins (fig. 155).

(13) Make certain that the extensions on the operating levers and on the retaining finger are positioned under the spring plungers.

(14) Pass the loading guide screws through the frame and the loading guides, and pass the operating lever bracket screws through the frame, the lever bracket, and the loading guides, and secure by means of their nuts.

(15) Pull out the wires from the plungers to release them.

i. LINK CHUTE SUPPORT GROUP (FIGS. 133 AND 134). (1) Assemble the link chute front support to the frame, near the front feed wheel, using the support screws and nuts. Similarly, assemble rear support to frame near rear feed wheel.

(2) The tips of the supports should point toward feed wheels.

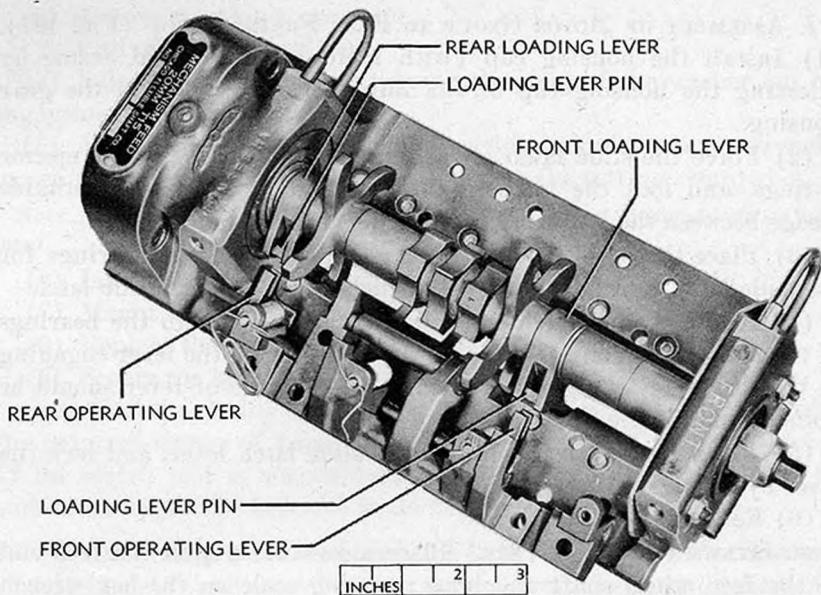

RA PD 94083

Figure 155. 20-mm right-hand feed mechanism M3—Engaging operating lever with loading lever pins.

(3) The link chute front support has the words "SUPPORT FRONT" stamped on it; the link chute rear support has the words "SUPPORT REAR" stamped on it.

j. LINK CHUTE AND STRIPPER COVER GROUP (FIG. 130). (1) Mount the link chute on the feed frame, with the stud secured to the bottom of the chute, in engagement with a hole in the feed frame.

(2) Position the stripper cover over the feed frame, with the holes for receiving the link chute and stripper cover pin in alinement with the holes in the chute supports.

(3) Pass the link chute and stripper cover pin through the cover, the supports, and the chute.

(4) Secure the link chute and stripper cover pin by means of a cotter pin.

k. EJECTOR GROUPS (FIGS. 128 AND 129). (1) Place the ejector in the bottom of the feed mechanism.

(2) Position the ejector springs on the bottom of the feed mechanism with the ends of the springs in the openings of the ejector.

(3) Secure the slide latch plate to the bottom of the feed mechanism by means of six screws, confining the ejector and the ejector springs in position.

(4) Wire the screws.

(5) Mount the slide latch on the bottom of the feed mechanism under the slide latch plate.

7. ASSEMBLY OF MOTOR GROUP TO FEED FRAME GROUP (FIG. 127).

(1) Install the housing cap (with motor) on the feed frame by inserting the housing cap screws into the screw holes in the gear housing.

(2) Force the slide latch inward against the action of the ejector springs, and lock the latch in this position by inserting a suitable wedge between the latch and the housing cap.

(3) Place the slide latch operating cam between the bearings for the slide latch lever, with the operating surface toward slide latch.

(4) Pass the slide latch lever from the left through the bearings of the housing cap and the cam, with the spline on the lever engaging in the corresponding groove of the cam. Handle of lever should be pointed up at angle toward front of feeder.

(5) Place washer on the end of the slide latch lever, and lock the lever by means of a cotter pin.

(6) Remove the wedge.

m. DYNAMIC TORQUE TEST. Place a bar wrench on the free end of the feed wheel shaft and hook a spring scale on the bar wrench (fig. 156). Move the scale in a direction opposite to the direction of feed with the motor running. The scale reading should be from 151½ to 161½ pounds. If the reading does not fall within this range, being either more or less, it is necessary to adjust the setting of the clutch. To do so—

(1) Remove the housing cap together with the motor.

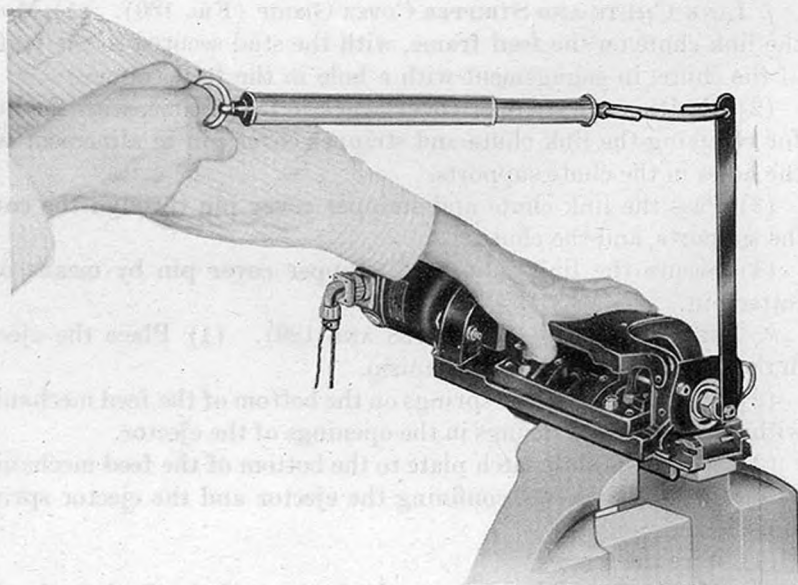

RA PD 49005

Figure 156. 20-mm right-hand feed mechanism M3—Dynamic torque test.

- (2) Remove the planet gear unit.
- (3) Pull off the internal gear.
- (4) Release the lock nut by moving the tang of the washer out of engagement with the nut.

(5) Adjust the nut by means of the bearing lock nut spanner wrench, loosening or tightening it in order to obtain the setting required.

Note. A quarter turn of the nut equals approximately a 25-pound-inch adjustment.

- (6) Lock the nut by one of the tangs of the washer.
- (7) Mount the internal gear on the end of the gear housing.
- (8) Replace the planet gear unit.
- (9) Secure the housing cap with the motor to the feed frame.
- (10) Test the setting of the clutch again to be sure that it transmits the required torque of from 155 to 165 pound-inches at motor speed. If the clutch still is not set correctly, it will be necessary again to tighten or loosen the lock nut in the manner just described.

87. Disassembly and Assembly of Left-Hand Feed Mechanism

The disassembly and assembly instructions given above for right-hand feed mechanism can also be followed in disassembling and assembling a left-hand feed mechanism. However, the instructions in paragraph 88j and figures 157 to 166 should be consulted for correct assembly of feed wheel shaft parts, operating lever bracket parts, link chute supports, stripper cover and link chute, cover locking pins, and motor.

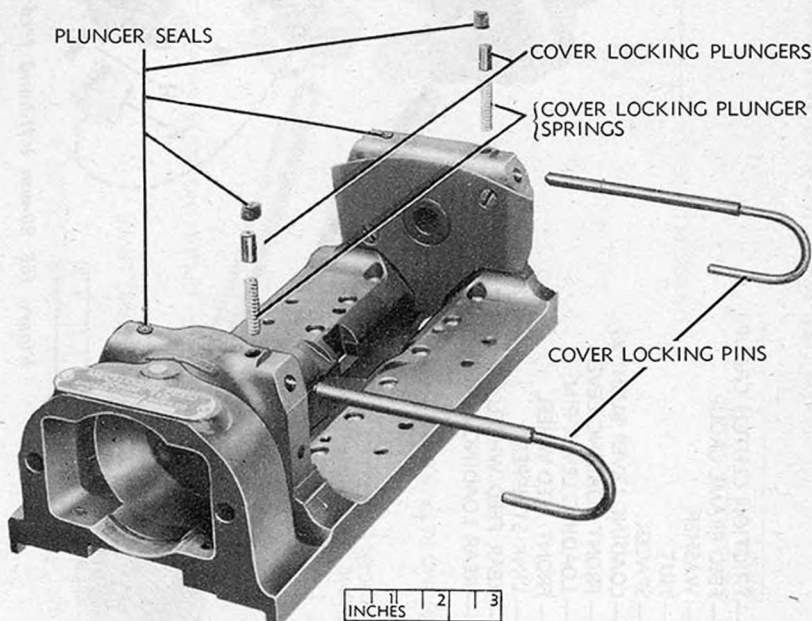

Figure 157. 20-mm left-hand feed mechanism M3—Cover locking pin group.

RA PD 94014

- A** — FRICTION CLUTCH GROUP
B — FEED FRAME GROUP
C — WASHER
D — NUT
E — SPACER
F — LOADING LEVER BUSHING
G — FRONT LOADING LEVER
H — LOADING LEVER PIN
J — FRONT FEED WHEEL
K — LINK STRIPPER
L — REAR FEED WHEEL
M — REAR LOADING LEVER

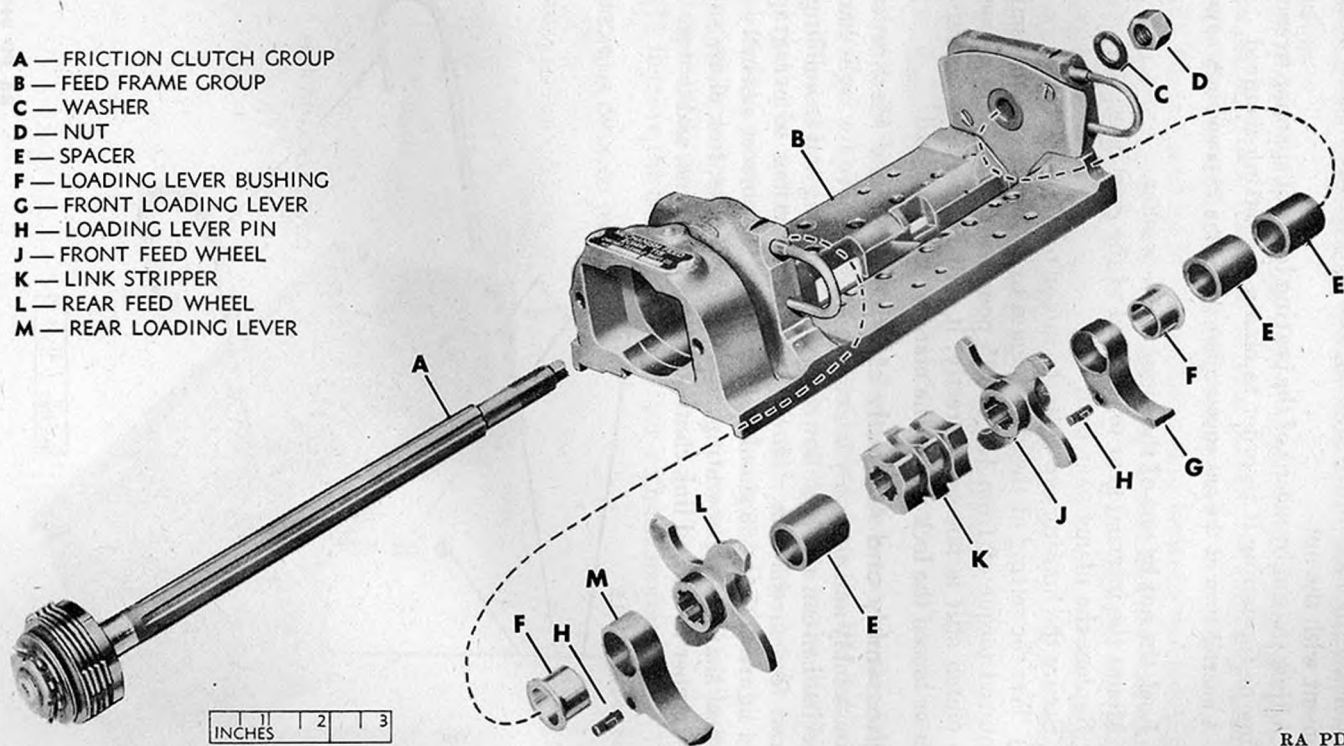
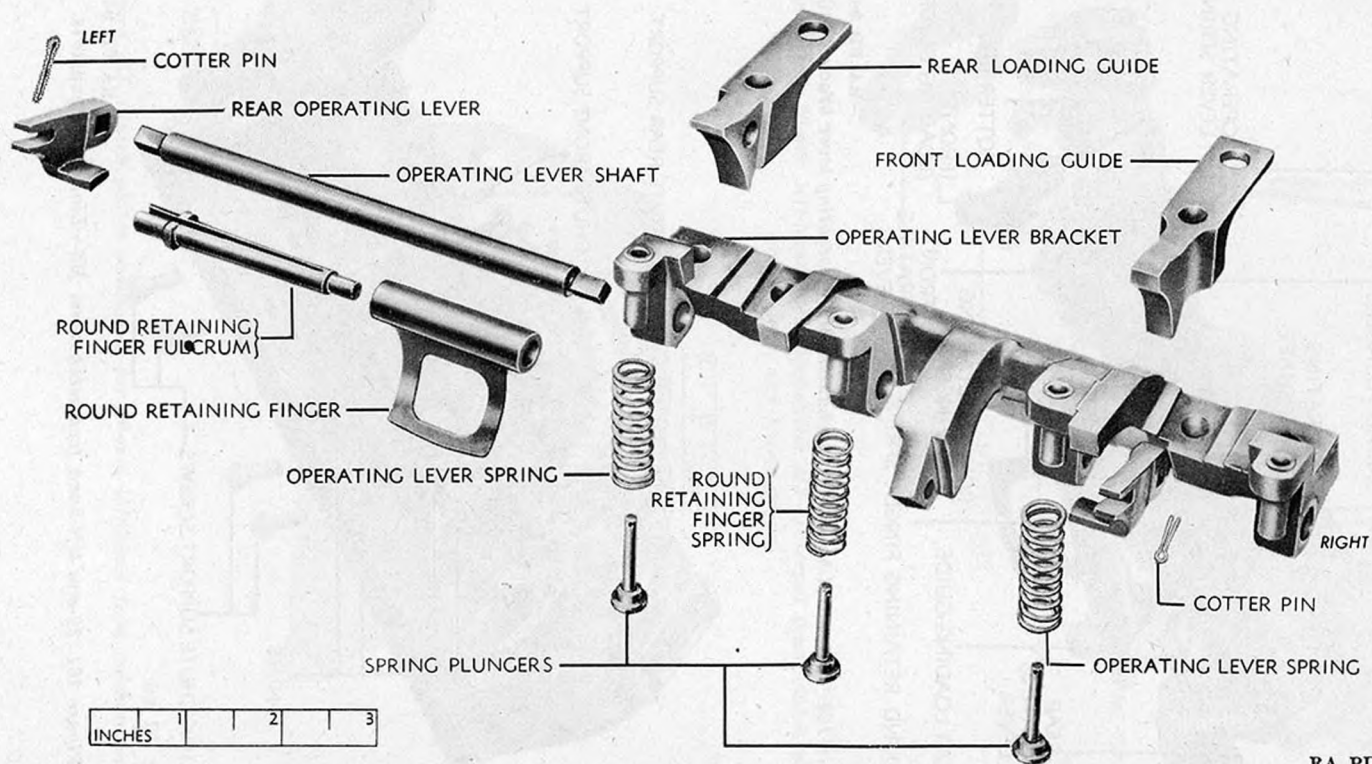
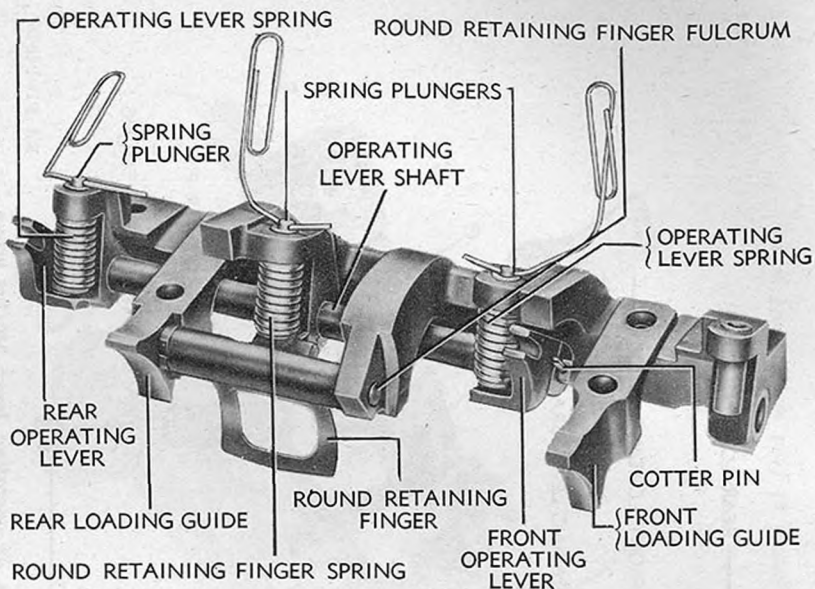

Figure 158. 20-mm left-hand feed mechanism M3—Parts of feed wheel shaft group.



RA PD 94079

Figure 159. 20-mm left-hand feed mechanism M3—Parts of operating lever bracket group.



RA PD 94076

Figure 160. 20-mm left-hand feed mechanism M3—Operating lever bracket group.

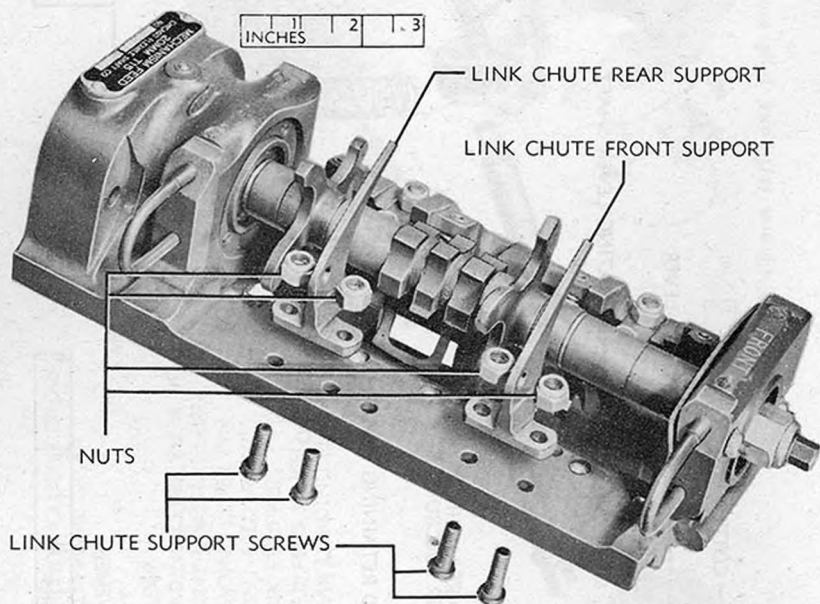

RA PD 94015

Figure 161. 20-mm left-hand feed mechanism M3—Link chute supports.

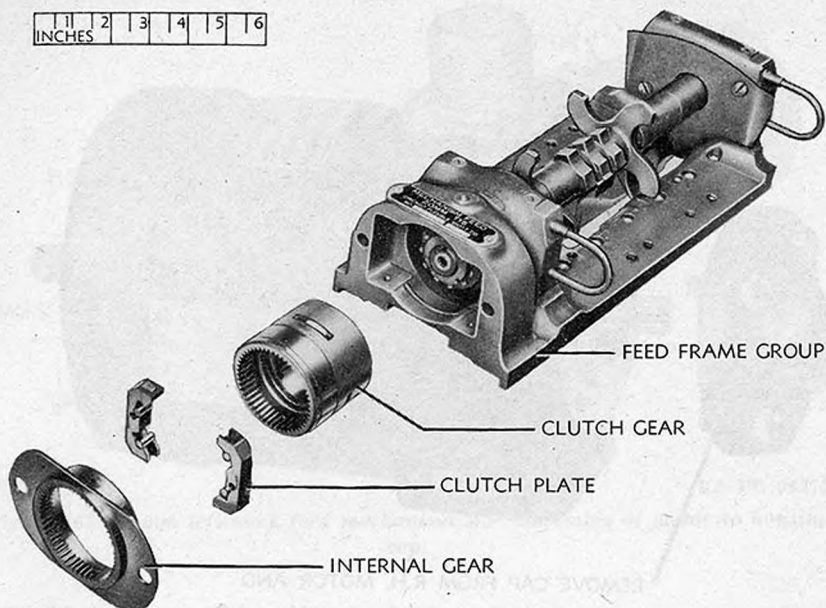
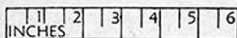

RA PD 94013

Figure 162. 20-mm left-hand feed mechanism M3—Internal gear, clutch plates, clutch gear, and frame group.

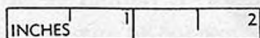
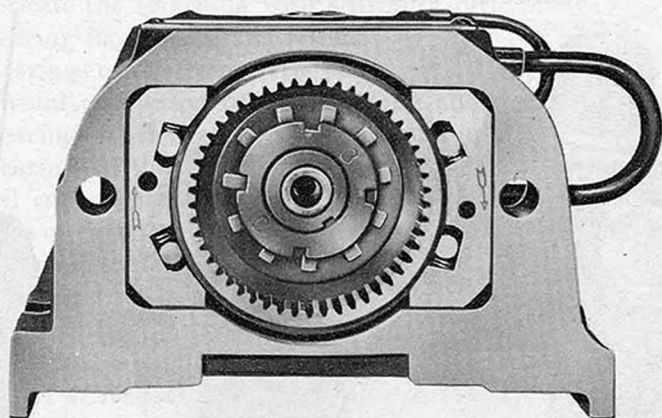

RA PD 94078

Figure 163. Clutch plates positioned for 20-mm left-hand feed mechanism M3.

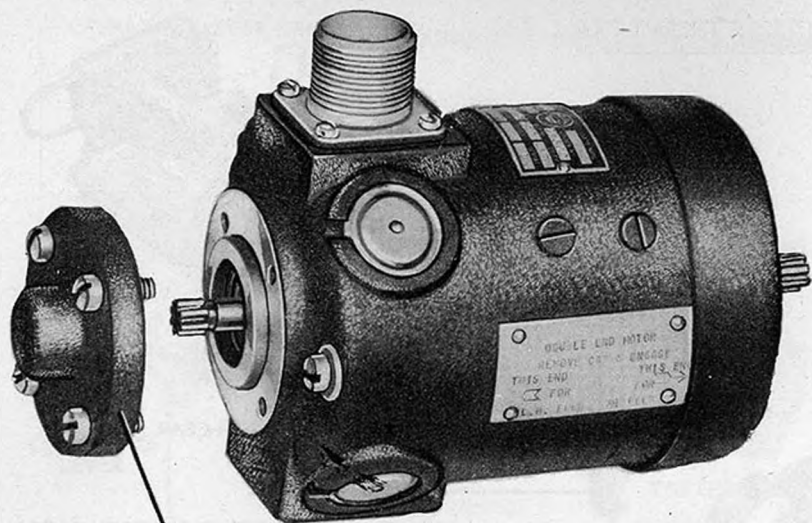

REMOVE CAP FROM R.H. MOTOR AND

INSTALL CAP ON OTHER SHAFT TO MAKE A L.H. MOTOR

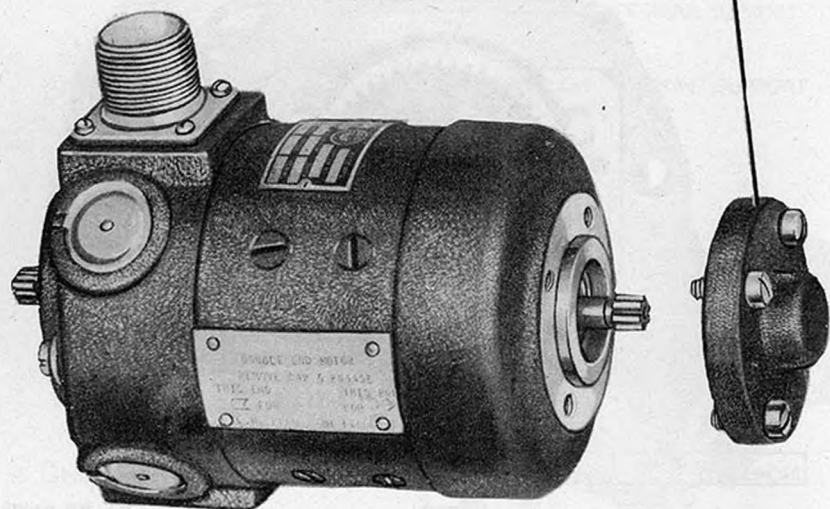

RA PD 94073

Figure 164. 20-mm feed mechanism M3—Changing right-hand motor to left-hand motor.

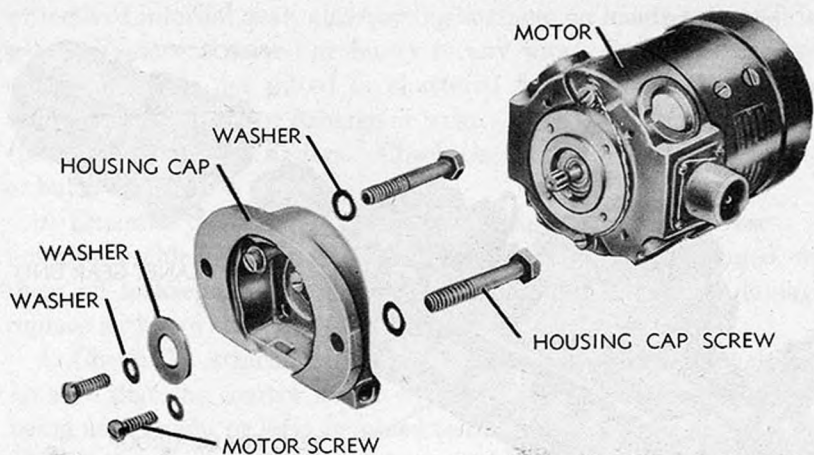

RA PD 94075

Figure 165. 20-mm left-hand feed mechanism M3—Assembly of motor to housing cap.

88. Maintenance by Using Arms

a. Weekly and before firing clean all accessible parts with dry-cleaning solvent and then wipe with a cloth dampened with preservative lubricating oil (special). If disassembly is undertaken, clean and oil all disassembled parts before assembling.

b. Lubricate the following with a drop of oil:

- (1) Bearing faces of loading levers.
- (2) Bearings of operating lever shaft.
- (3) Pivotal connection between loading and operating levers.
- (4) Bearings of the retaining finger fulcrum.
- (5) Bearings of the slide latch.
- (6) Oil cup on gear box (3 drops of oil).
- (7) Pins of cartridge control pawl and cartridge holding dog.
- (8) Balls and sockets of links.
- (9) Front and rear bearings.
- (10) Pivots of cartridge holding cams.

c. Inspect feed mouth for wear. Look for grooves or excessive wear at lower part of feed mouth. Determine serviceability of ejector and ejector mounting and test slide latch assembly. Inspect the feed plate; if dented or excessively worn, replace. Test the oil cup for clear passage or correct action. If faulty, install a new cup. See that cover locking pins, spring, and plungers are satisfactory. Remove any burrs or dents with a fine stone. Test springs for serviceability. Replace any part found defective.

d. Inspect the front and rear link chute supports. Curved inward surfaces of each support must be smooth and of a uniform radius.

1	2	3
INCHES		

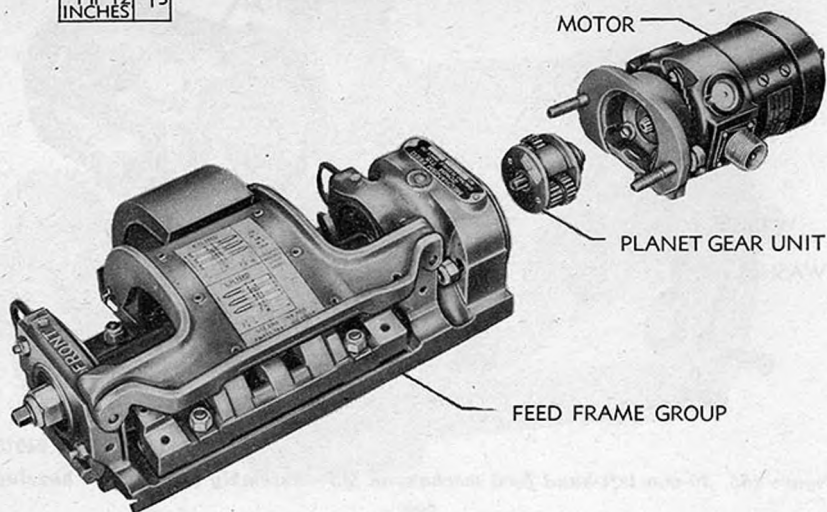

RA PD 94074

Figure 166. 20-mm left-hand feed mechanism M3—Assembly of motor and planet gear unit to feed frame.

This radius forms part of the cartridge control and therefore the condition of this surface is critical. Replace these parts if necessary. Check the link chute for damage or wear. Inspect the welded joint around the fastening brackets. Cracks at these points would render the assembly unserviceable. Replace the chute if found unserviceable. Stripper cover pin should be straight and free from any burrs. Inspect the mounting screws and securing nuts for stripped threads or defaced heads.

e. Check free rotation of feed wheel shaft. Inspect the feed wheel shaft for wear or damage. See that the threads on the forward end are not stripped or excessively worn. Remove any nicks from the splines and inspect the bearing surfaces on either end. Inspect the round retaining finger for sharp corners on its lower surface. Test round retaining finger fulcrum for cracks. Replace either of these parts with new if in doubtful condition. See that spring plungers are not damaged or bent. If either front or rear loading guides are damaged or bent, replace with new parts. Inspect operating lever bracket for damage. If deformed or damaged, replace. Examine operating lever shaft and front and rear operating levers. If bent, replace.

f. Clean and inspect the housing cap internal gear, clutch gear, safety clutch parts (which include plates, rolls, and springs), and the planet gear unit. Discard any unserviceable parts. Inspect conditions

of teeth of internal gear, also bearing surfaces on inside and outside of gear. Replace if scored or faulty in any way. See that clutch gear outer surface is not pitted or chattered from clutch rolls. Inspect teeth of clutch gear for damage or wear. Test the planet gear unit by spinning it with the fingers. Check the teeth for excessive backlash or burs.

g. Examine the bearings for wear, damage, or missing covers. Do not disassemble bearings. If bearings are not worn or damaged, wipe them off to keep dirt from working inside and install; if damaged, replace with new ones.

h. Check the attachment of the motor to the feed mechanism to be sure that the correct motor end for the type of feed mechanism being used (right or left) is joined to the feed mechanism. The plate on the motor identifies the right and the left motor end. Examine electric motor for damaged or broken parts. If any parts are broken, replace.

i. If feed mechanism still malfunctions after all worn or broken parts have been replaced, turn the mechanism over to ordnance maintenance personnel.

j. To convert right-hand feed mechanism to left-hand proceed as follows:

(1) Disassemble the right-hand feed mechanism as instructed in paragraph 85*a, c, d, e, f, g, i,* and *l.* In addition, remove the other two plunger seals from the vertical openings on the feed frame and insert them in openings on opposite side (fig. 157) (par. 86*d*).

(2) Assemble the cover locking pin group (par. 86*d*) on the right side of the feed frame (fig. 157).

(3) Assemble the feed shaft group (par 86*f*) with arrows on feed wheels, link stripper, and loading guides pointing in opposite direction to that of right-hand feed mechanism (fig. 158).

(4) Assemble the operating lever bracket group (par. 86*h*); install the retaining round finger spring (with plunger) on the second pin from the left, and the operating lever springs (with plungers) on the first and third pins from the left (figs. 159 and 160). Assemble the operating lever shaft (with operating levers) through the first three shaft holes on the left (fig. 159). Assemble the round retaining finger and fulcrum to the middle bracket and the front loading guide (figs. 159 and 160). Slots in fulcrum should be horizontal.

(5) Assemble the link chute front and rear supports (par. 86*i*) on side opposite to that of operating lever bracket (fig. 161).

(6) Assemble the stripper cover and link chute (par. 86*j*).

(7) Install the clutch gear (par. 86*g*) (fig. 162). Assemble and

install the clutch plates (par. 86*g*), but make certain that the arrows on the plates point in the direction of feed (fig. 163). Install the internal gear (fig. 162).

(8) Install the planet gear unit.

(9) Remove the four screws which secure the cap to the motor and replace the cap over the motor shaft on the other end (fig. 164). Assemble the motor to the housing cap (par. 86*l*) but with the receptacle toward cap (fig. 164).

(10) Assemble the housing cap (and motor) to the feed frame (par. 86*l*).

k. To convert left-hand feed mechanism to right-hand proceed as follows:

(1) Disassemble the left-hand feed mechanism as instructed for right hand feed mechanism in paragraph 85*a, c, d, e, f, g, i,* and *l*. In addition, remove the other two plunger seals from the vertical openings in feed frame and insert them in openings on opposite side of frame (par. 86*d*).

(2) Assemble the parts into a right-hand feed mechanism as described in paragraph 86. Make certain that the left-hand motor is converted to a right-hand motor as shown in figure 164.

89. Maintenance by Ordnance Maintenance Personnel

a. GENERAL. Perform maintenance operations given in paragraph 88 whenever necessary.

b. FEED FRAME. To replace the feed mouth, remove the tubular rivets and feed mouth from frame. Position a new feed mouth in place on frame and locate with four pins, made from 1/4-inch drill rod (fig. 167). Install the rivets and buck them securely in place. Remove the four locating pins.

c. STRIPPER COVER. Examine stripper cover plate for condition. If dented or warped, replace as follows:

(1) Carefully remove the six tubular rivets and cover plate (fig. 168).

(2) Mount a new cover plate in position and install two center rivets first.

(3) Use extreme caution when riveting to apply just enough pressure to the rivet to have cover plate snug but not warped (fig. 169).

(4) Install the four remaining rivets in the same manner.

d. OPERATING LEVER BRACKET PARTS. (1) Examine operating lever bracket shaft for straightness; if bent, straighten. Reshape ends with a file if necessary.

(2) Examine spring plungers for straightness and, if necessary, straighten.

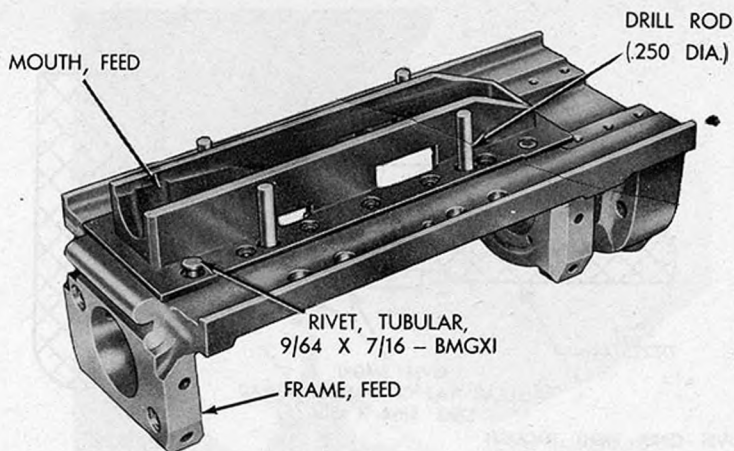

RA PD 91100

Figure 167. 20-mm feed mechanism M3—Assembling feed mouth to frame.

(3) Examine operating lever bracket for cracks, indications of fracture, or elongated holes. If these conditions exist, replace the bracket.

(4) Check the spring guide pins on the bracket for looseness; if

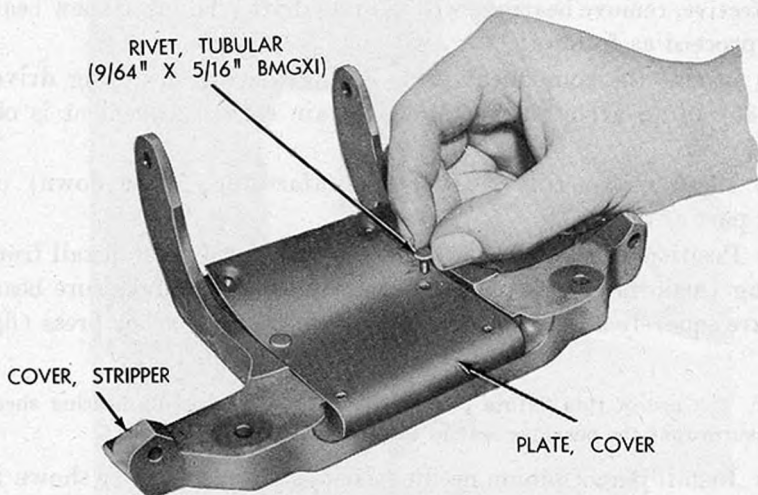

RA PD 91091

Figure 168. 20-mm feed mechanism M3—Attaching cover plate to stripper cover.

pin is loose, file off the riveted end of the pin, remove the pin, and examine hole. If hole is elongated, replace the lever bracket. If hole is not elongated, replace the pin and rivet the end with a rivet spinner.

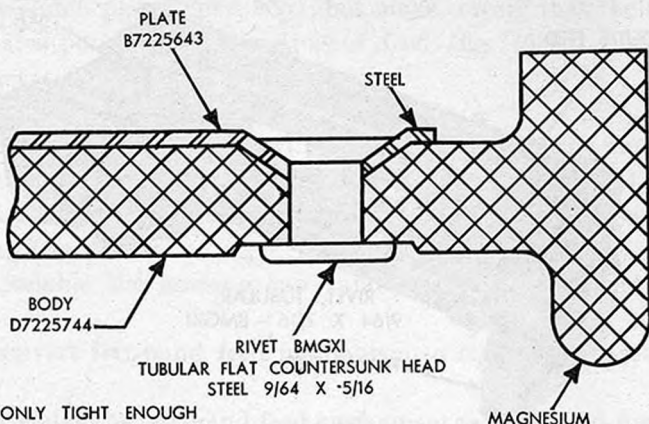

NOTE: RIVET ONLY TIGHT ENOUGH TO SEAT FLAT PORTION OF PLATE ON CASTING WITHOUT DISTORTION.

RA PD 91034

Figure 169. 20-mm feed mechanism M3—Method of riveting cover plate to stripper cover.

e. PLANET GEAR UNIT. (1) Disassemble the planet gear unit.

(2) Clean and inspect the needle bearings in the pinions and cage. If defective, remove bearings with a brass drift. To install new bearings, proceed as follows:

(a) Mount the component parts of the bearing installing driver (fig. 35) in an arbor press. Make certain correct alignment is obtained.

(b) Place rear needle bearing (manufacturer's name down) on lower part of driver.

(c) Position cage down over bearing on the fixture and install front bearing (manufacturer's name up) on top of cage. Make sure bearings are squarely aligned and seat them in place with arbor press (fig. 170).

Note. The use of this fixture prevents damage to the needle bearing shells and insures that the bearings seat to the proper depth in the cage.

(d) Install planet pinion needle bearings with the driver shown in figure 34. Be sure manufacturer's marks are out when bearings are installed. Both bearings can be installed at the same time with this set-up (fig. 170).

f. FEED WHEEL SHAFT AND FRICTION CLUTCH UNIT. (1) Examine the feed wheel shaft for straightness by placing it in a pair of V-blocks, having the two bearing surfaces in contact with the V-blocks. If more

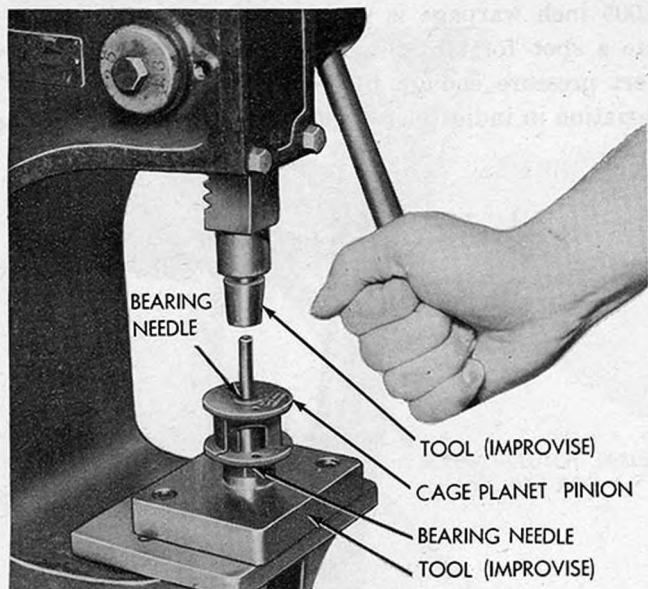

A—INSTALLING PLANET PINION CAGE BEARINGS

STANDARD ARBOR PRESS

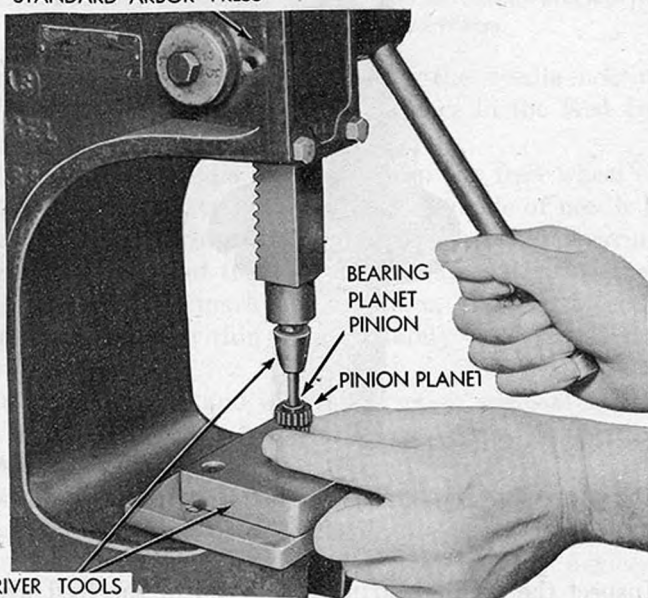

B—INSTALLING PLANET PINION BEARINGS

RA PD 91076

Figure 170. 20-mm feed mechanism M3—Installing needle bearings in planet cage.

than 0.005 inch warpage is noted on an indicator, mark the shaft to locate a spot for straightening. Position under an arbor press and exert pressure enough to straighten. Test with the indicator until variation in indicator reading is no more than 0.005 inch.

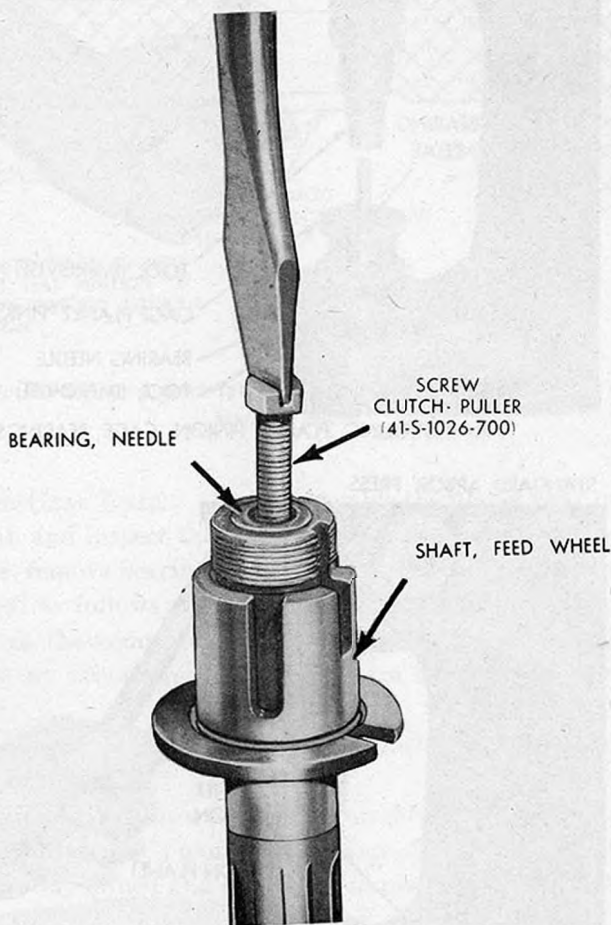

RA PD 91096

Figure 171. 20-mm feed mechanism M3—Extracting needle bearing from feed wheel shaft.

(2) Inspect the needle bearing in the end of the feed wheel shaft by rotating with a small piece of wire.

Note. Do not remove this bearing unless damage has been noted.

(3) To remove bearing, insert clutch puller screw (fig. 28) through the needle bearing and into the bearing block. Continue turning this screw with a wrench or screwdriver until bearing is extracted (fig. 171).

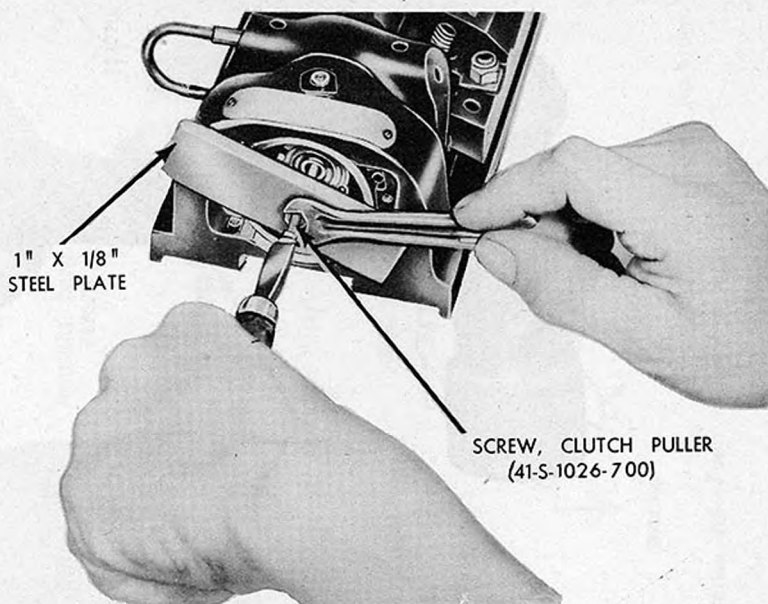

RA PD 91064

Figure 172. 20-mm feed mechanism M3—Extracting needle bearing from feed wheel shaft assembled to feed frame.

(4) An alternate method of extracting the needle bearing, employed when feed wheel shaft is still in place in the feed frame, is shown in figure 172.

(5) To replace the needle bearing, clamp the feed wheel shaft in a vise equipped with safety jaws. Coat the outside of needle bearing housing with a film of white lead pigment. Install the bearing block in the recess in the end of the feed wheel shaft. Position the needle bearing (manufacturer's mark up) in place, and tap into the feed wheel shaft until it is within approximately $\frac{1}{64}$ inch of the block (fig. 173).

(6) Thoroughly clean and examine friction washers and friction disks of the clutch. If deep scores or excessive wear is noted, replace all the disks.

(7) Examine the three Belleville springs. Replace these springs if they have flattened out or if cracks are noted. Do not reuse outer spacer and lock washer; always use new locking devices when assembling.

(8) Examine the rear and front ball bearings and test for operation by spinning, and discard if found unserviceable.

g. ELECTRIC MOTOR. (1) *Disassembly.* Cut the locking wire from the four screws securing the cap to motor and remove the four screws and cap from the motor (fig. 174). Pry out the four brush lock rings, holding the brushes in place and remove brush caps, brush

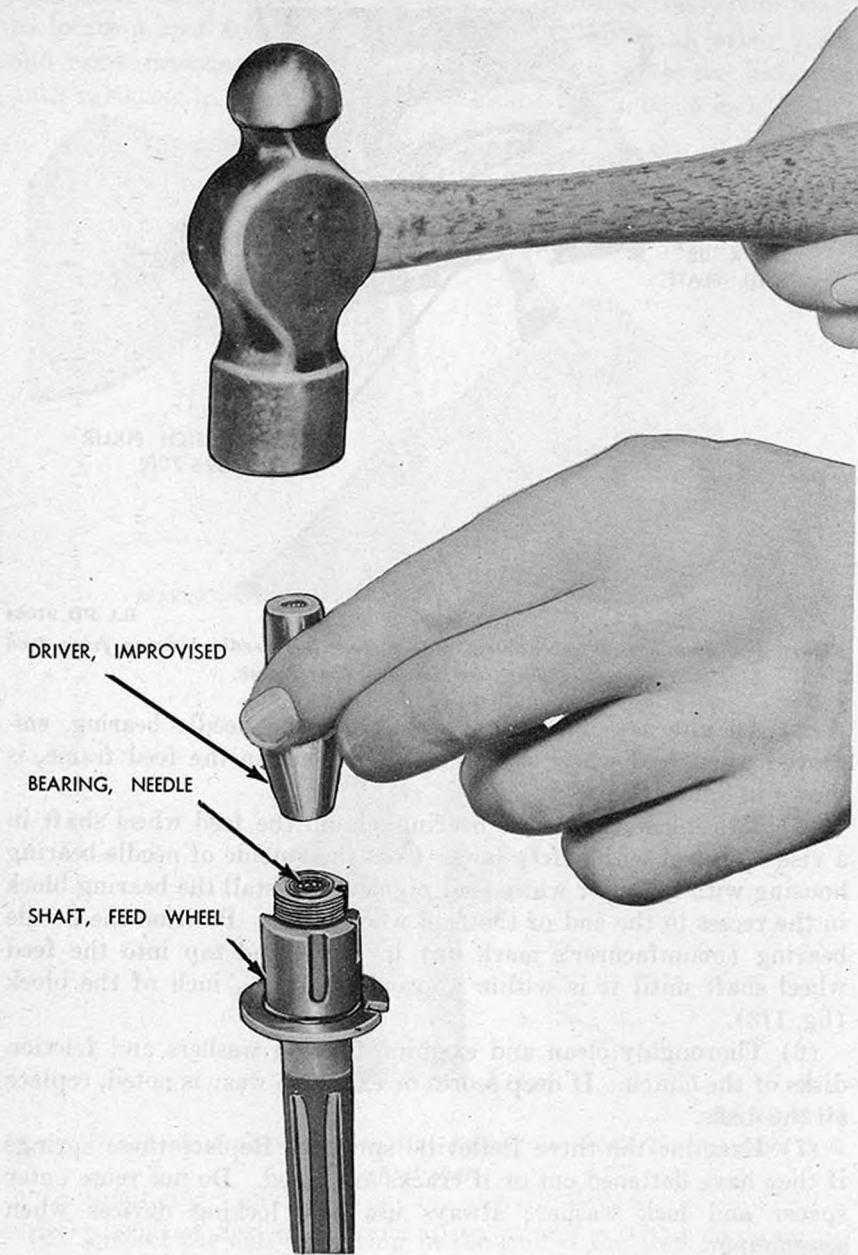

RA PD 110931

Figure 173. 20-mm feed mechanism M3—Installing needle bearing in feed wheel shaft.

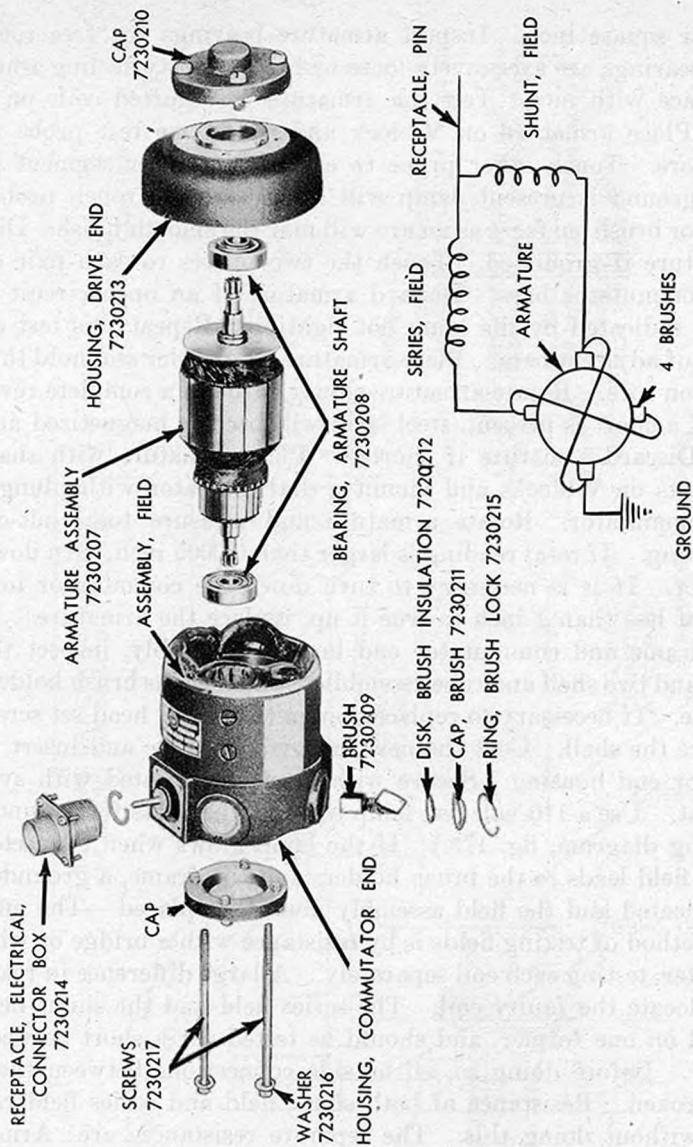

RA PD 91060

Figure 174. 20-mm feed mechanism M3—Parts of electric motor.

insulation disks, and brush and spring assemblies. Cut the locking wire and remove the two long cap screws and lock washers. Carefully pull the armature assembly from the field assembly.

(2) *Cleaning.* Wipe off all parts with a dry, clean cloth. Blow out the field assembly and commutator with compressed air. Do not use cleaning solvent on the motor parts.

(3) *Inspection and repair.* Replace brushes if oil-soaked, chipped, worn below a length of $\frac{5}{16}$ inch, or if spring tension is less than 2

pounds per square inch. Inspect armature bearings for free rotation. If bearings are excessively loose or have a gritty feeling when spun, replace with new. Test the armature for shorted coils on a growler. Place armature on V-block and touch one test probe to shaft or core. Touch other probe to each commutator segment in turn. If ground is present, lamp will light. Do not touch probes to bearing or brush surfaces as an arc will mar the smooth finish. Discard armature if grounded. Touch the two probes to each pair of adjacent commutator bars. Discard armature if an open circuit is present as indicated by the lamp not lighting. Repeat this test on every pair of adjacent bars. Place armature on growler and hold thin steel strip on core. Rotate armature slowly through a complete revolution. If a short is present, steel strip will become magnetized and vibrate. Discard armature if shorted. Place armature with shaft bearing seats on V-blocks and mount a dial indicator with plunger against commutator. Rotate armature and measure total out-of-round reading. If total reading is larger than 0.0005 inch, turn down commutator. If it is necessary to turn down the commutator to a diameter of less than 1 inch to true it up, replace the armature. In the field frame and commutator end housing assembly, inspect the two shells and two shell and tube assemblies, which act as brush holders for damage. If necessary to replace, loosen the socket head set screw and remove the shell. Coat the new shell with shellac and insert in commutator end housing. Secure with a setscrew coated with synthetic paint. Use a 110-volt test lamp to check the fields for grounds. (See wiring diagram, fig. 175.) If the lamp glows when connected across the field leads to the brush holders and the frame, a grounded coil is indicated and the field assembly must be replaced. The only positive method of testing fields is by resistance with a bridge or with an ohmmeter, testing each coil separately. A large difference in readings will locate the faulty coil. The series field and the shunt field are wound on one former, and should be tested for a short between each other. Before doing so, all outside connections between them must be broken. Resistance of both shunt field and series field can be taken without doing this. The separate resistances are: Armature—0.0565 ohms; shunt field—19.8 ohms; series field—0.0252 ohms. Replace field frame assembly if one or more coils are defective. If receptacle is defective, cut the locking wire from the four receptacle screws and remove the screws and receptacle. Remove the snap ring to separate the field lead from the receptacle. Connect a new receptacle to the field lead and mount on commutator end housing with four fillister head screws. Safety-wire the four screws together.

(4) *Assembly.* Coat bearing recesses with white-lead pigment. Install the armature and bearing assembly in the field frame (fig. 174). Press drive end housing over the armature and secure with two lock

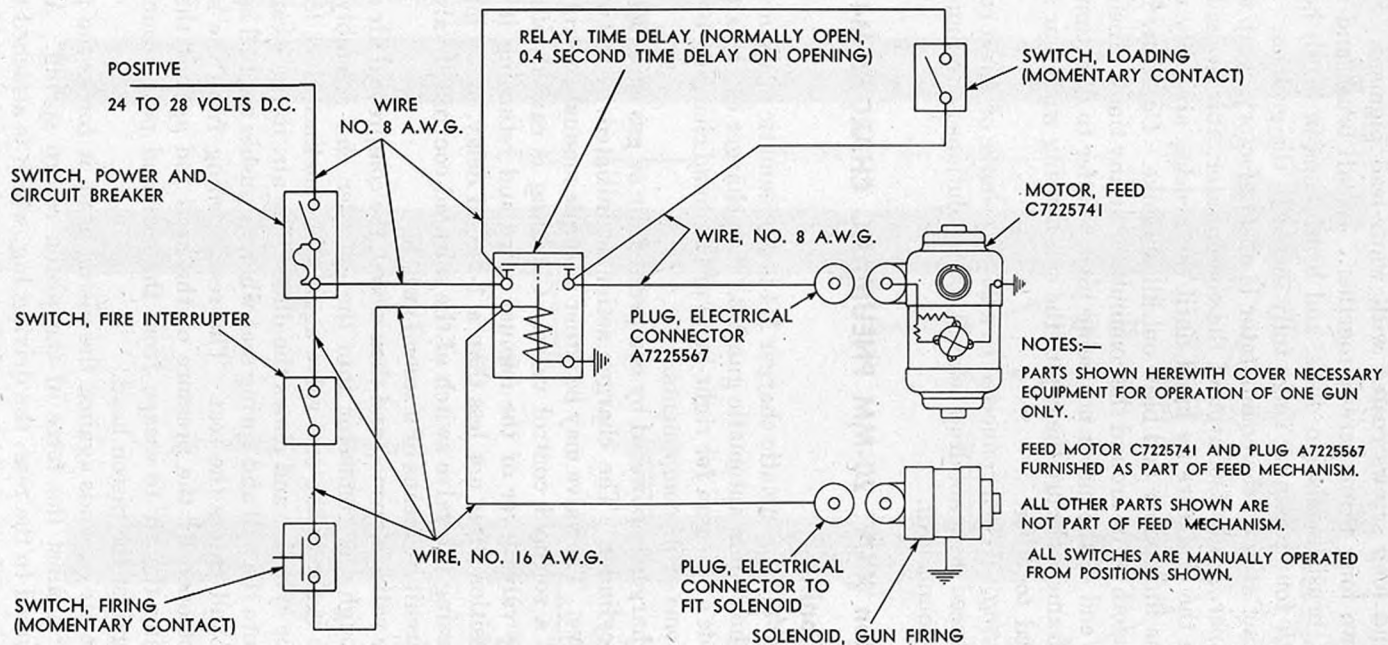

Figure 175. 20-mm feed mechanism M3—Wiring diagram.

RA PD 26717

washers and long screws coated with white-lead pigment. Safety-wire the two long frame screws together. Install brush and spring assemblies, brush insulation disks, and brush caps in brush holders. Secure with four retaining rings fully seated in the grooves. If the brush contact area on the commutator is unsatisfactory, wrap a strip of flint paper, grade 2/0, around the commutator, abrasive side out, and rotate the armature by hand until the brushes are fully seated. Remove the flint paper and blow out all abrasive. **Caution:** Do not use emery cloth on or around the commutator at any time. Install the cap on the end of the motor not being used. Refer to direction plate on motor frame. Secure the cap to the end housing with four screws safety-wired together.

(5) *Testing.* When connected to a 26-volt source of direct current, the motor speed must not drop below 8,000 revolutions per minute with a 4.6-inch-pound load.

Section XXIV. 20-MM PNEUMATIC CHARGER M4

90. Functioning

a. The 20-mm pneumatic charger M4 is a pneumatic mechanism for charging the 20-mm automatic gun M3. The charger can be attached to either side of the gun for right-hand or left-hand charging by repositioning some of its components.

b. The charger is powered by compressed air or gas supplied from a storage cylinder. The charger action is initiated by a two-way control valve. The valve may be either a simple manual control valve (fig. 5) or a solenoid control valve. Charging is caused either by moving the valve lever of the manual valve and returning it to its original position after not less than a 1-second delay, or by momentarily squeezing the valve switch of the solenoid controlled valve and breaking circuit by means of a second switch.

c. As the valve is opened and then closed, the compressed air or gas passes through the connector into the cylinder end assembly (fig. 176) where it forces the end valve against the inclined duct leading into charger cylinder and closes the duct. The air, in the meantime, continues into the ball and spring seat where it pushes the ball against the spring and enters the seat. The rear opening from the seat is always kept open by the pressure of the head rod against the ball, thus allowing the air to escape from the seat and pass around the head rod against the piston head.

d. As the air expands against the piston head, it forces the piston to the rear against the force of the piston return spring. As the piston is forced to the rear, the driving lug, which is attached to the piston, engages the breechblock slide and moves the breechblock to the rear against the force of the driving spring. As the breechblock

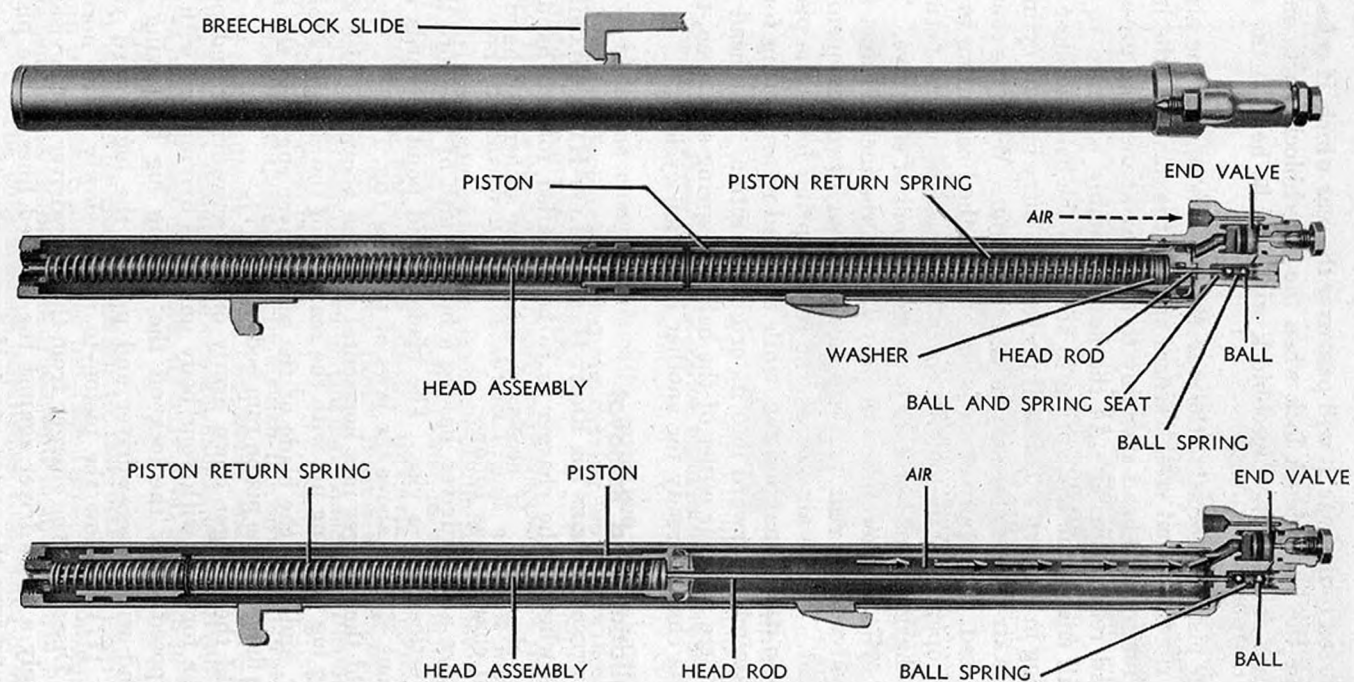

RA PD 94065

Figure 176. Functioning of 20-mm pneumatic charger M4.

is being forced to the rear, it will pass over the sear which, if released, will engage the breechblock lock when the breechblock starts on its forward movement. The breechblock will thus be held in the rear position.

e. As the piston is forced to the rear, the inside bottom of the piston will push the brass and steel washers against the flange of the head rod, thus forcing the head assembly to the rear against the pressure of the head return spring. As the head assembly is forced to the rear, it will enable the ball spring to act upon the ball and close the rear opening in the seat. This will prevent the entry into the cylinder of any more air than is necessary to charge the gun. When the control valve is closed, the supply of air is cut off, and the line leading to the charger is opened to the outside, permitting escape of air between valve and charger, thus lowering pressure in front of end valve. The air in the cylinder therefore will pass up into the inclined duct and force the valve to the rear, and will escape through two side openings in valve seat. As the air escapes, the return spring forces the piston forward into its original position, while the head return spring forces the head assembly forward into its original position. The head rod will now force the rear outlet of the ball and spring seat open, thus keeping the charger ready for another operation cycle.

91. Installation and Removal

a. ADJUSTING CHARGER FOR RIGHT-HAND OR LEFT-HAND CHARGING. Determine whether the charger is to be installed for left-hand or right-hand charging. If necessary, adjust for either left-hand or right-hand charging as follows:

(1) Secure a screwdriver, having a blade width of not more than $\frac{1}{4}$ inch, vertically in a vise. The blade should point upwards and extend about $\frac{3}{4}$ inch above the jaws of the vise (fig. 177).

(2) Hold the charger in a horizontal position above the vise with the driving lug pointing up, with the rear end of the charger against your body, and with the blade of the screwdriver engaging the slot behind the flange of the piston ram body (fig. 177).

(3) Hold the charger down firmly on the screwdriver and push the charger forward with your body until the driving lug with its lock is exposed. Pry the lock off the driving lug by prying the notched end with a screwdriver and pulling the lug toward your body (fig. 177). Allow the piston to return slowly to its normal position. Disengage the charger from the screwdriver in the vise.

(4) Apply a screwdriver against the knurled lines on the piston ram body and turn the piston one-half turn so that the recess for the lug aligns with the slot on the opposite side of the charger (due to the spring action, it is easier to turn the piston in the same direction in which the return spring is wound).

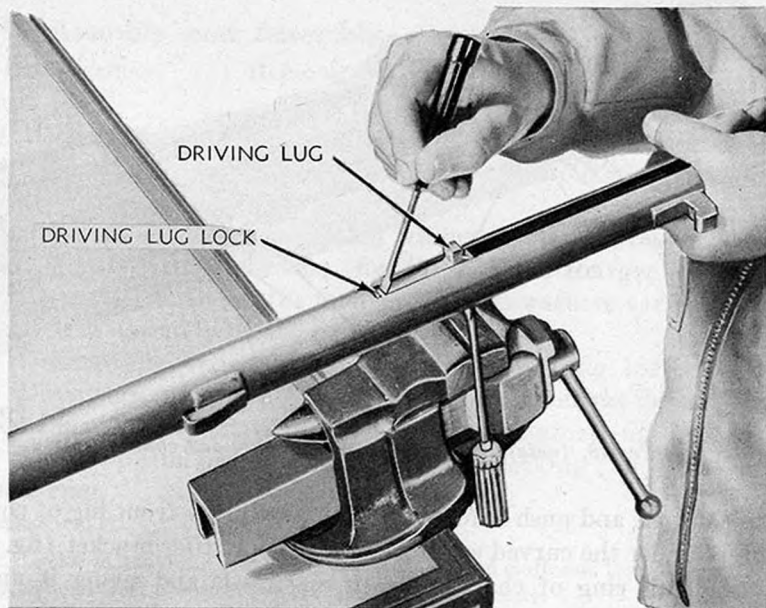

RA PD 94064

Figure 177. 20-mm pneumatic charger M4—Removal of driving lug.

(5) Hold the charger vertically, with the conical cylinder nut down, and shake gently so that the driving lug lock will slide down the piston close to the piston ram.

(6) Hold the charger in a horizontal position above the vise with rear end of charger against your body, and with the blade of the screwdriver engaging the slot behind the flange of the piston ram body.

(7) Place the driving lug (notched end leading) in the recess in the piston ram body. Push charger forward with your body and position the lug on the piston ram. With a screwdriver, snap the driving lug lock into the notch on the lug. Allow the piston to return slowly to its normal position.

b. MOUNTING CHARGER. (1) Attach the mounting bracket to the side of the cradle by means of two screws and lock-wire the screws (fig. 178). The flange of the bracket should be on outside of cradle, and the curved seat of bracket directly over the edge of the cradle (fig. 178).

(2) Attach the charger clamp to rear end of cradle, using the clamp pin, washer, and cotter pin (fig. 178). The washer should be installed on the inside of the cradle and inside the arm of the yoke (fig. 178). The yoke must be installed so that, when looking down, the angle surface in the crotch of the yoke can be seen (fig. 178).

(3) Hold the charger above the edge of the cradle with the driving lug toward the side of the gun and the head toward the muzzle. Lower

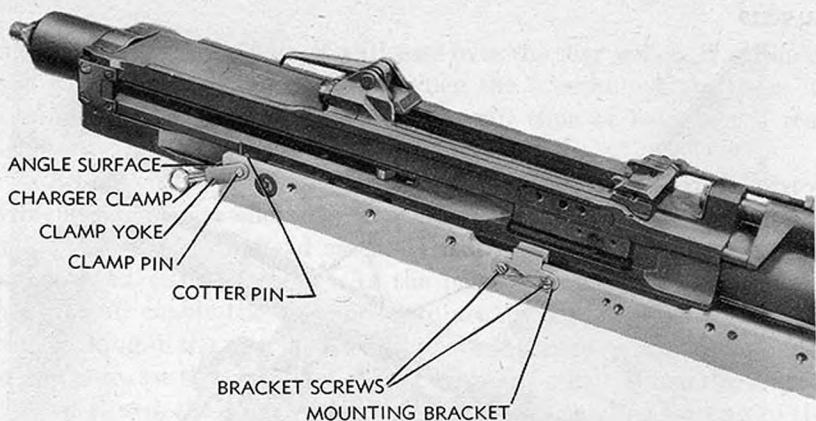

RA PD 93962

Figure 178. Installation of mounting bracket and charger clamp.

the charger, and push it forward so that cylinder front lug of charger enters under the curved surface of front mounting bracket (fig. 179).

(4) Pull ring of charger clamp rearwards and swing it up into horizontal position and release ring, allowing plunger of charger clamp to enter seat in cylinder rear lug of charger (fig. 179).

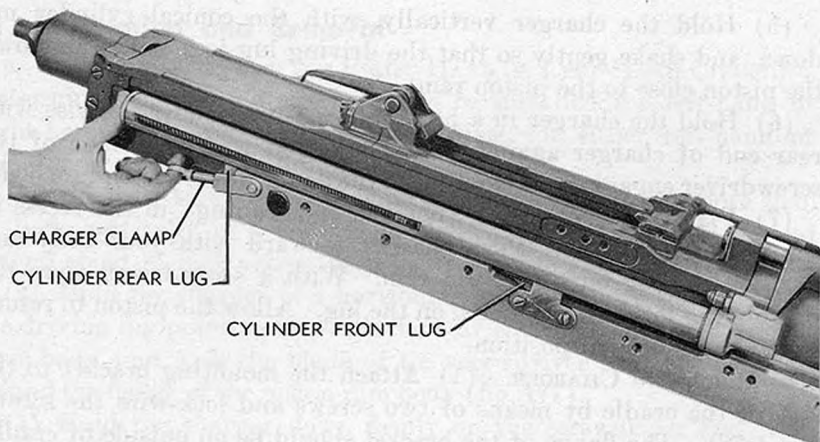

RA PD 93963

Figure 179. Mounting 20-mm pneumatic charger M4 on gun.

c. **DISMOUNTING CHARGER.** (1) Pull the charger clamp ring rearwards and swing it down so that the plunger is disengaged from rear cylinder lug.

(2) Lift the rear end of charger slightly until cylinder rear lug is disengaged from the cradle, and pull the charger to the rear off the cradle.

92. Disassembly and Assembly

a. **DISASSEMBLY.** (1) Remove the driving lug (par. 91a(1), (2), (3), and (4)).

(2) Back off the lock ring and unscrew the cylinder end assembly (fig. 180). The piston assembly will be pushed out by the piston return spring (fig. 181).

(3) Remove the three steel spring washers and any brass washers (fig. 181) from inside the piston (fig. 181). Each charger will have three steel spring washers; the number of brass washers varies and is determined at assembly by the manufacturer.

(4) Unscrew the connector from the cylinder end (fig. 181).

(5) Disengage tang of piston packing ring from the piston nut, unscrew the nut, and remove piston gasket and retainer (fig. 181).

(6) Remove piston packing ring and piston packing (fig. 181). Do not reuse ring.

b. ASSEMBLY.

Note. Prior to assembly, clean all parts with a clean cloth and then wipe with a cloth dampened with preservative lubricating oil (special).

(1) Insert the piston packing (round end leading) into the piston head (fig. 181).

(2) Insert piston packing spring.

(3) Insert a new piston packing ring into the gasket (fig. 181).

(4) Insert the gasket retainer and piston gasket into the piston nut, screw the nut into the piston head (fig. 181), and engage tang of ring with nut.

(5) Hold the head assembly vertical, with the rod of the head assembly pointing up, and slip the steel washers around the rod. The washers must be installed in reversed positions so as to give a spring effect (fig. 181); then slip the brass washers around the rod.

(6) Slip the piston around the rod, making certain the rod goes through the opening in the piston head. Turn the head and piston upside down so that the brass piston rests on the bench. Withdraw the head assembly from piston. This should only be done when necessary to replace parts.

(7) Slip the spring guide (flanged end leading) around the rod of the head assembly and screw the head into the cylinder and stake in place. This should only be done when necessary to replace parts.

(8) Insert the return spring into the piston while keeping open end of piston up.

(9) Hold the cylinder vertical, directly above open end of piston with rod pointing down into piston. Press the cylinder down against spring pressure until rod passes through the washers and the opening in piston head. While holding the piston in this position, screw the cylinder end into the cylinder.

RA PD 94068

Figure 180. Disassembly of 20-mm pneumatic charger M4.

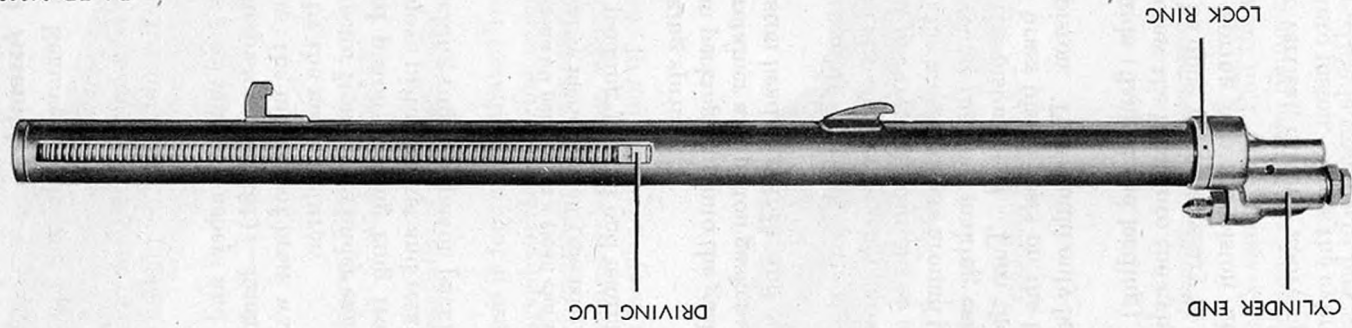

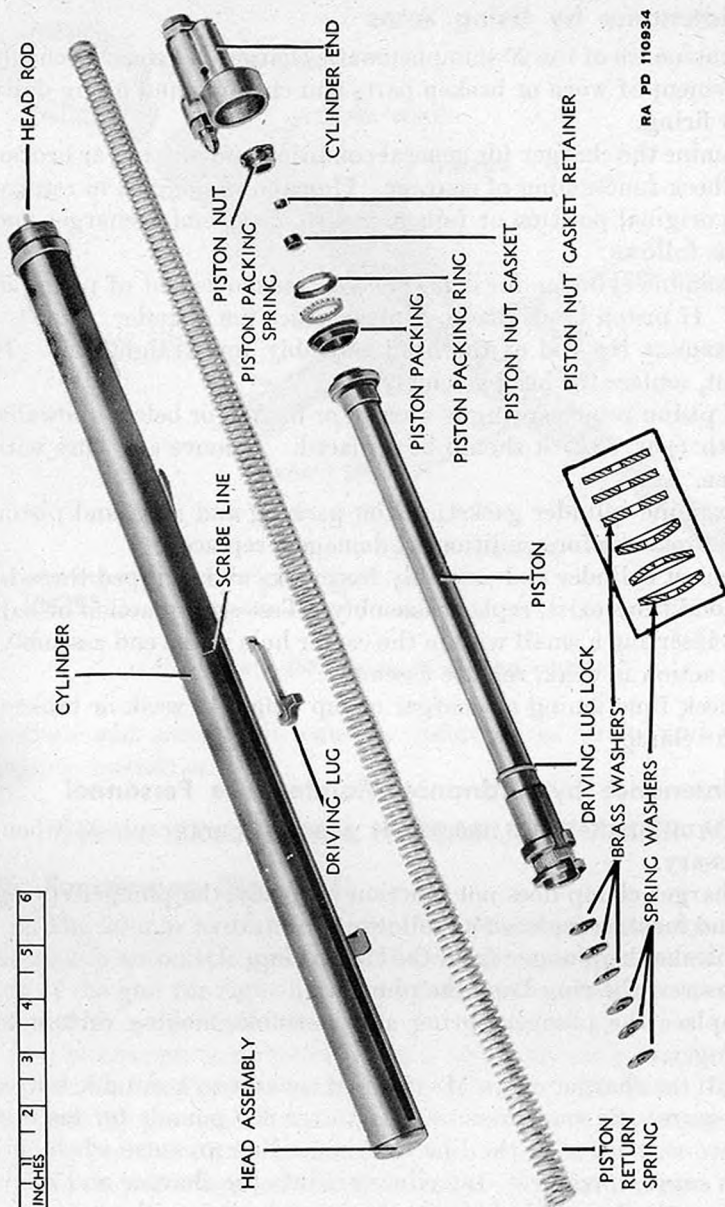

Figure 181. 20-mm pneumatic charger M4—Parts of cylinder and piston assemblies.

(10) Replace the driving lug (par. 91a (5), (6), and (7)).

(11) Adjust the stroke position of the operating face of the driving lug by screwing or unscrewing the cylinder end until the lug face aligns with the scribe line near the slot on the cylinder (fig. 180); then back off the head until it is at right angles to the slots in the cylinder.

(12) Push the cylinder gasket against the head, and screw the lock ring tightly against the end.

93. Maintenance by Using Arms

a. Maintenance of the 20-mm pneumatic charger M4 consists chiefly of replacement of worn or broken parts and cleaning and oiling daily and after firing.

b. Examine the charger for general condition and missing or broken parts. Check functioning of charger. If piston is sluggish in returning to its original position or fails to return, disassemble charger and proceed as follows:

(1) Examine cylinder for dents; check free movement of piston in cylinder. If piston binds due to dents, replace the cylinder.

(2) Examine the rod of the head assembly for straightness. If rod is bent, replace the head assembly.

(3) If piston return spring is warped or broken or below allowable free length (par. 38*h*) it should be replaced. Remove any burs with an oilstone.

(4) Examine cylinder gasket, piston packing and ring, and piston gasket and retainer for condition; if damaged, replace.

(5) Inspect cylinder end assembly for cracks and stripped threads. If these conditions exist, replace assembly. Test spring action of ball checks by inserting a small wire in the center hole in the end assembly. If spring action is weak, replace assembly.

(6) Check functioning of charger clamp ring. If weak or broken, replace the clamp.

94. Maintenance by Ordnance Maintenance Personnel

a. Perform maintenance operations given in paragraph 93 whenever necessary.

b. If charger clamp does not function properly, the plunger spring is weak and must be replaced as follows:

(1) Unstake the plunger from the clamp ring.

(2) Unscrew the ring from the plunger.

(3) Replace the plunger spring and assemble, making certain to stake plunger.

c. Install the charger on an M3 gun and connect to a suitable source of air pressure. Be sure pressure is not over 800 pounds for testing. Have a two-way valve in the line to exhaust line pressure when cutting main supply pressure. Introduce air into the charger and allow it to retract the breechblock. See that the charger will retract the breechblock $\frac{1}{8}$ inch more than is needed to sear it. If charger stroke is less than this, disassemble charger and remove one of the spacing washers. To decrease charging stroke, add washers. The breechblock requires a total travel of $9\frac{1}{8}$ inches to sear, plus $\frac{1}{8}$ inch safety margin. The stroke of the charger should not be more than the above dimension as a waste of compressed air would result. Make sure charger retracts quickly. Test all joints for leakage of air pressure. Loose con-

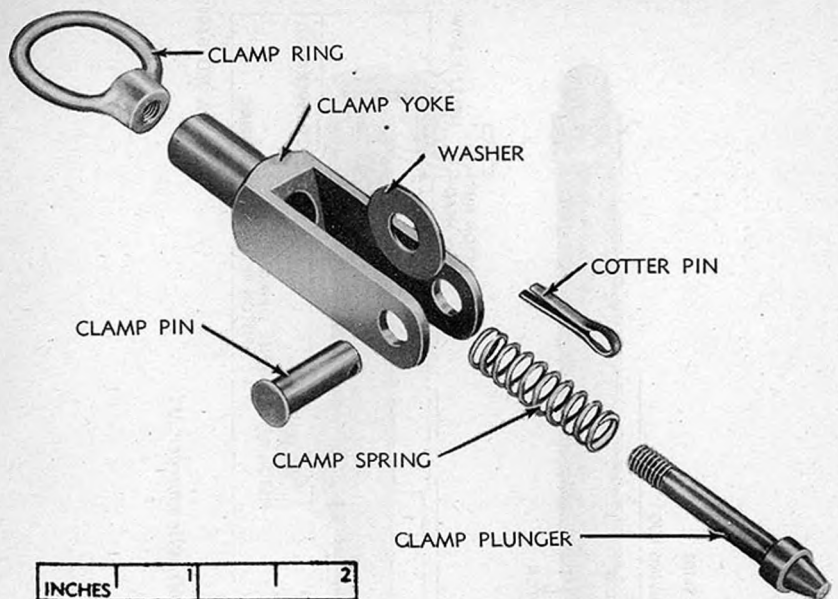

RA PD 93953

Figure 182. Parts of charger clamp.

nections and screws will cause a difference in stroke and result in sluggish operation.

Section XXV. 20-MM HYDRAULIC CHARGER M7

95. Functioning (Fig. 183)

a. The 20-mm hydraulic charger M7 is a mechanism for charging the 20-mm automatic gun M3. The charger can be attached to either side of the gun for right-hand or left-hand charging by repositioning some of its components.

b. The charger is powered by fluid under pressure supplied from a pump. The charger action is initiated by a control valve. Charging is caused by moving the handle of the valve and returning it to its original position after not less than a 1-second delay.

c. As the valve is operated, fluid is forced under pressure from the pump through the inlet elbow and cylinder head against the piston head. As the pressure of the fluid acts against the piston head, it forces the piston assembly to the rear against the force of the piston return inner and outer springs. As the piston is forced to the rear, the driving lug, which is secured to the piston, contacts the lug on the breechblock slide and moves the breechblock to the rear against the pressure of the driving spring. As the breechblock is being forced to the rear, it will pass over the sear which, if released, will engage the

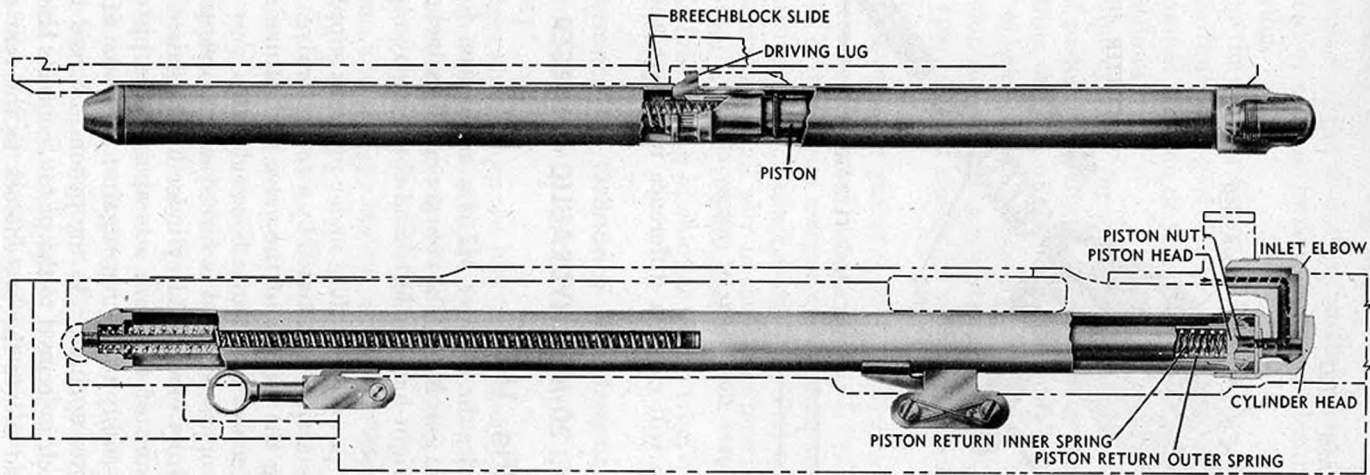

Figure 183. Functioning of 20-mm hydraulic charger M7.

RA PD 94069

breechblock lock when the breechblock starts on its forward movement. The breechblock will thus be held in the rear position.

d. When the handle of the valve is returned to its original position, the pressure from the pump against the fluid in the charger ceases and, as a result, the piston return springs recover and force the piston to its original position, pushing the fluid out from the charger into the reservoir from which it is circulated to the pump.

96. Installation and Removal

a. ADJUSTING CHARGER FOR RIGHT-HAND OR LEFT-HAND CHARGING. Proceed as in paragraph 91a.

b. MOUNTING CHARGER. Proceed as in paragraph 91b. The mounted charger is shown in figure 184.

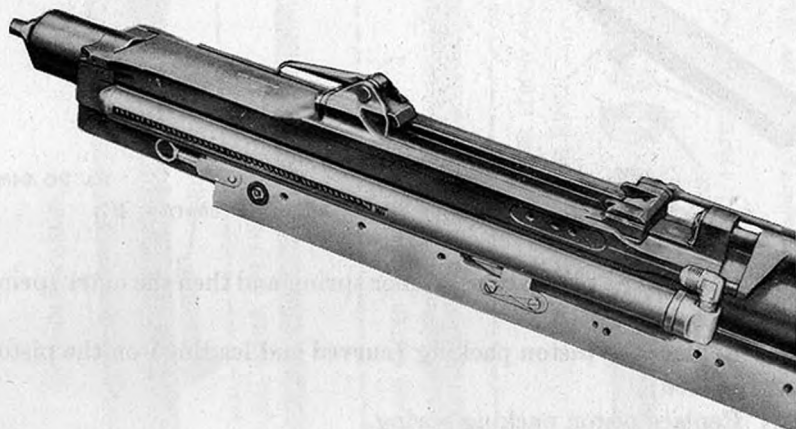

RA PD 93943

Figure 184. 20-mm hydraulic charger M7 installed on gun.

c. DISMOUNTING CHARGER. Proceed as in paragraph 91c.

97. Disassembly and Assembly

a. DISASSEMBLY. (1) Remove the driving lug (par. 91a(1), (2), (3), and (4)).

(2) Back off the lock ring and unscrew the head and elbow (fig. 185). The piston assembly will be pushed out by the springs. Keep out of the way of the springs.

(3) Withdraw the springs (fig. 186).

(4) Disengage the tang of the piston packing ring from the piston nut and unscrew the piston nut (fig. 186).

(5) Remove the piston packing ring, the piston packing, and piston packing spring (fig. 186).

b. ASSEMBLY.

Note. Prior to assembly, clean all parts with a clean cloth and then wipe with a cloth dampened with preservative lubricating oil (special).

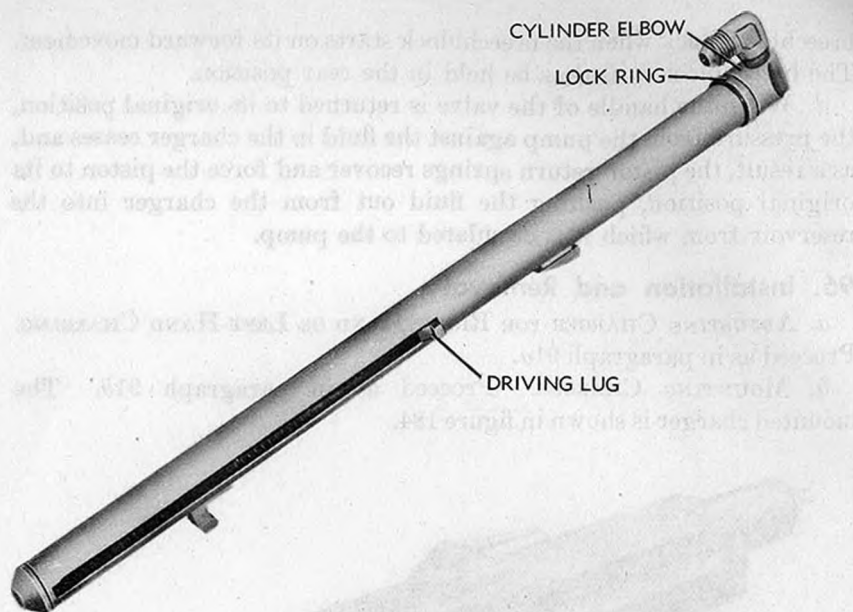

RA PD 94066

Figure 185. Disassembly of 20-mm hydraulic charger M7.

(1) Replace the piston return inner spring and then the outer spring (fig. 186).

(2) Replace the piston packing (curved end leading) on the piston head (fig. 186).

(3) Replace piston packing spring.

(4) Replace the piston packing ring (wide end leading) into groove in piston packing (fig. 186).

(5) Screw the piston nut into the piston head and lock the nut with a tang of the ring (fig. 186).

(6) Replace the piston (open end leading) in the cylinder (fig. 186).

(7) Install the driving lug (par. 91a(5), (6), and (7)).

(8) Screw in the cylinder elbow and head. Adjust stroke position of the operating face of the driving lug (par. 92b(11)).

(9) Push cylinder gasket against elbow.

(10) Screw the lock ring tightly against the elbow.

98. Maintenance by Using Arms

a. Maintenance of the charger involves mostly the replacement of worn or damaged parts and cleaning and oiling daily and after firing.

b. At frequent intervals examine the charger for leaks. If it leaks, replace the piston packing and/or cylinder gasket.

c. Replace any worn or broken packing ring or lock ring.

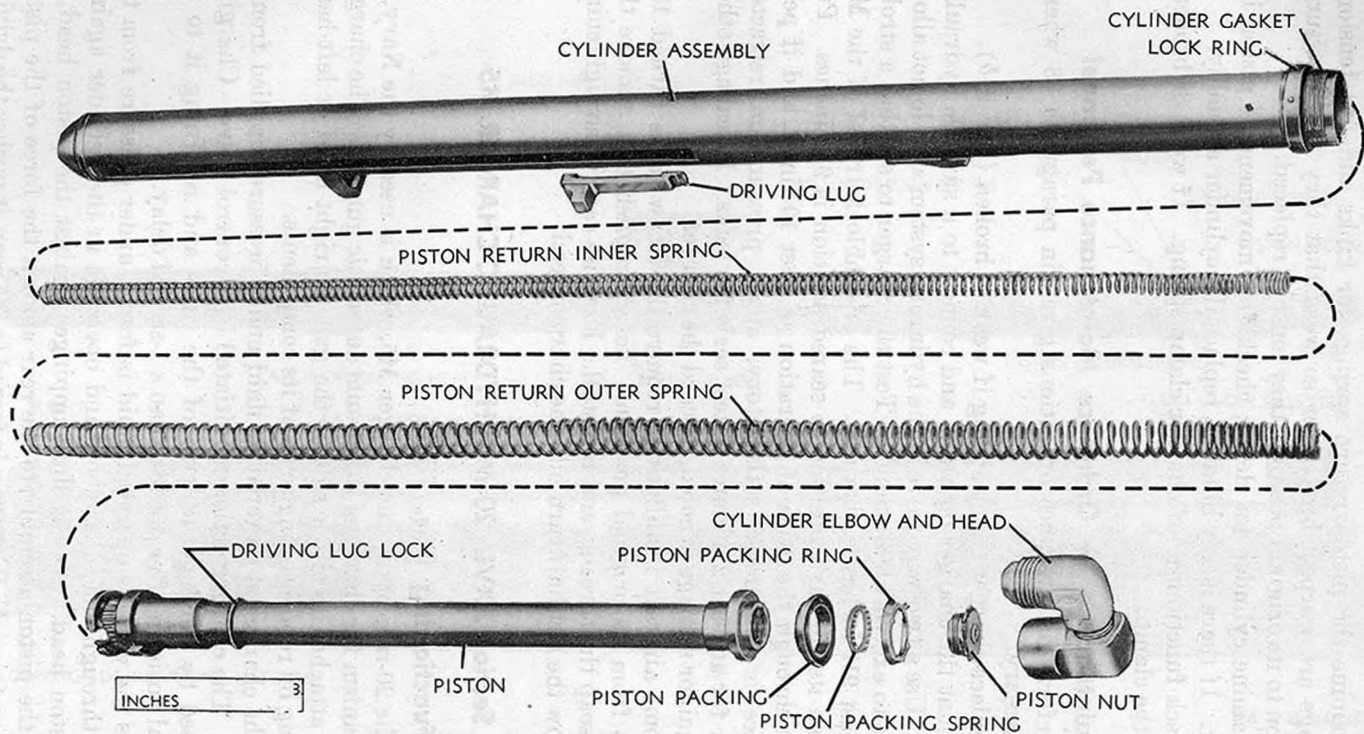

Figure 186. Parts of 20-mm hydraulic charger M7.

RA PD 108071

d. Examine the piston return springs for kinks and lost tension. If springs are warped, broken, or so weak that they fail to return the piston to its original position, they must be replaced.

e. Examine cylinder for dents; check free movement of piston in cylinder. If there is any binding, replace the cylinder assembly.

f. Check functioning of charger clamp spring. If weak or broken, replace the clamp.

99. Maintenance by Ordnance Maintenance Personnel

a. Perform maintenance operations given in paragraph 98 whenever necessary.

b. Replace charger clamp spring if weak or broken (par. 94*b*).

c. Mount the charger on a gun and connect to a suitable hydraulic supply. Use a two-way valve in the hydraulic system and do not allow pressure to exceed 1,000 pounds. Test the charger to see that a stroke of at least 9¼ inches is obtained. The breechblock travel of the M3 gun from its forward position to seared position is 9½ inches. Put charger through the cycle of operation at least 10 times, and if performance is considered satisfactory, apply pressure on retracted charger for at least 2 minutes to test seals for leaks. If leakage other than a minor seepage is noted, discard the charger.

d. Some aircraft installations require the elbow to be turned 180 degrees from its original position. To accomplish this, remove the elbow, soap the threads, and reinstall. Exercise care when tightening the elbow the last half turn into the charger head.

Section XXVI. 20-MM HYDRAULIC CHARGER M5

100. Functioning (Fig. 187)

a. The 20-mm hydraulic charger M5, which is used by the Navy, is a mechanism for charging the 20-mm automatic gun M3. The charger can be attached to either side of the gun for right-hand or left-hand charging by repositioning some of its components.

b. The charger is powered by fluid under pressure supplied from a pump. The charger action is initiated by a control valve. Charging is caused by moving the lever of the valve and returning it to its original position after not less than a 1-second delay.

c. As the valve is operated, fluid is forced under pressure from the pump through the inlet elbow and openings in the cylinder against the piston head. As the fluid impinges against the piston head, it forces the piston assembly to the rear against the force of the piston return spring. As the piston is forced to the rear, it pushes the driving lug against the lug of the breechblock slide, and moves the breechblock rearward against the pressure of the driving spring.

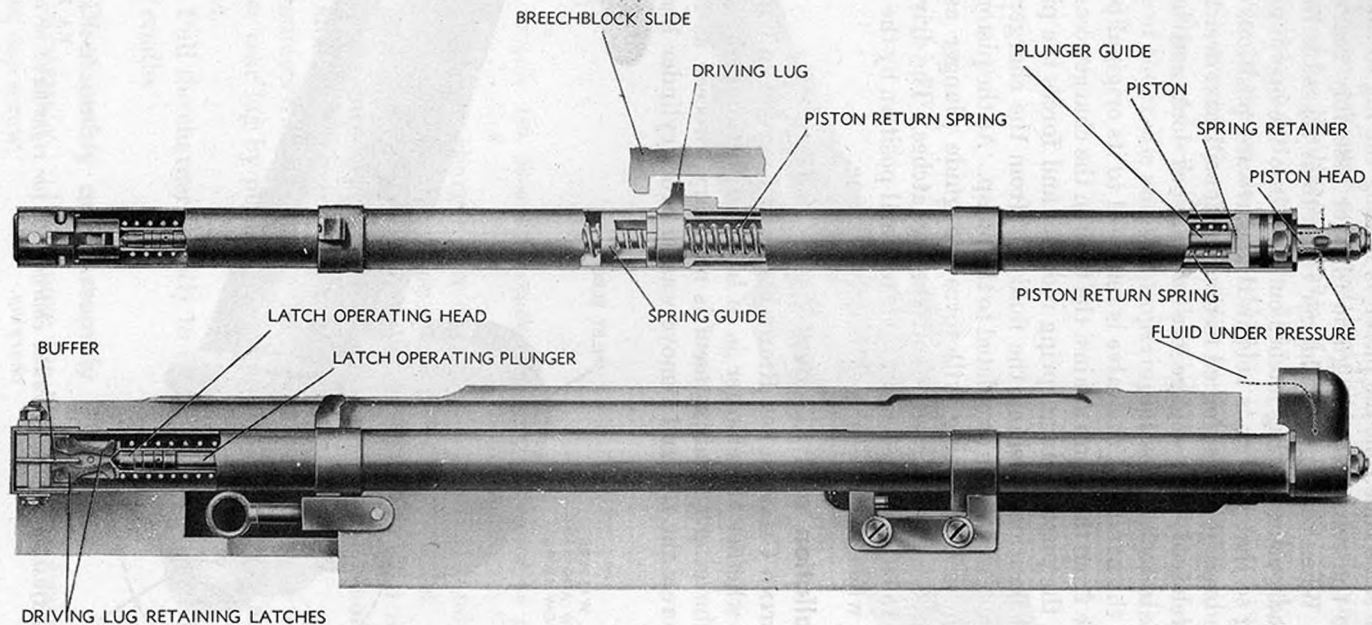

Figure 187. Functioning of 20-mm hydraulic charger M5.

RA PD 94026

d. At the same time that the piston is forcing the lug to the rear, it also pushes the return spring guide plunger assembly rearward in the guide. When the lug and plunger reach their rearmost limit, the plunger head pushes the lug latches outward into the openings of the driving lug so that the lug is held in this rearward position.

e. As the breechblock is forced to the rear it will pass over the sear which, if released, will engage the breechblock lock and hold the breechblock in cocked position.

f. When the handle of the valve is returned to its original position, the pressure from the pump against the fluid in the charger ceases and, as a result, the piston return spring recovers and forces the piston to its original position, pushing the fluid out from the charger into a reservoir from where it is circulated to the pump. As the piston moves forward, the return spring will force the guide plunger assembly forward and out of engagement with the lug latches. The driving lug will be free to be pushed forward to its original position by the breechblock slide when the breechblock is driven home.

101. Installation and Removal

a. ADJUSTING CHARGER FOR RIGHT-HAND OR LEFT-HAND CHARGING. Determine whether the charger is to be adjusted for right-hand or left-hand charging. If adjustment is necessary, proceed as follows:

(1) Unscrew the nut and remove washer from cylinder head (fig. 188).

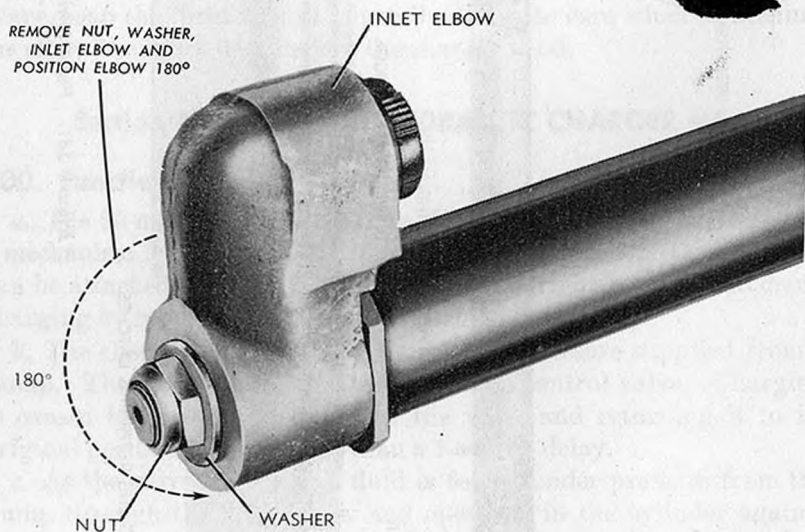

RA PD 94027

Figure 188. Adjusting 20-mm hydraulic charger M5 for right-hand or left-hand charging.

(2) Gently tap the inlet elbow off the cylinder head and reposition it 180 degrees (fig. 188).

(3) Secure the elbow with the washer and nut.

(4) When properly adjusted, the inlet elbow must point up when the driving lug is adjacent to side of receiver of gun.

b. MOUNTING CHARGER (FIG. 189). (1) Secure the charger clamp to the rear of the cradle (par. 91b(2)).

(2) Secure the mounting bracket to the cradle by means of the two lock washers and screws. The flange of the bracket should be on the outside of the cradle and the projecting pins directly over the edge of the cradle.

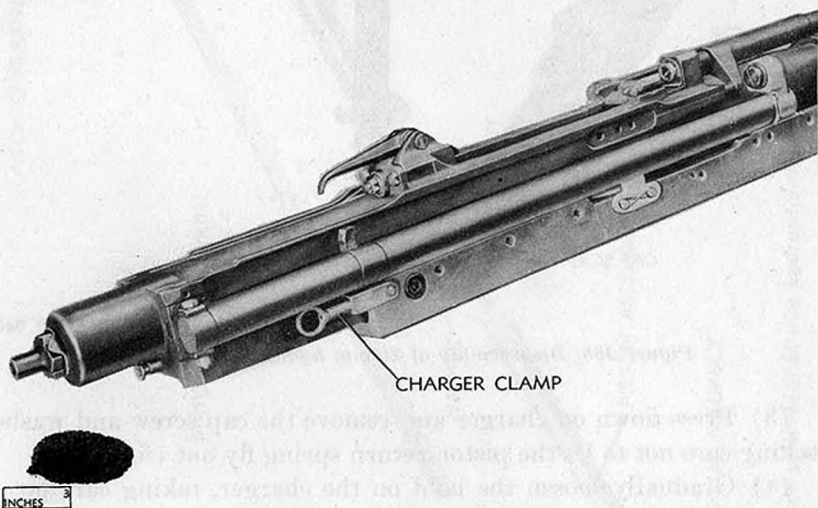

RA PD 94028

Figure 189. 20-mm hydraulic charger M5 installed on gun.

(3) Lower the charger over the edge of the cradle and engage the cylinder front lug with the pin of the mounting bracket.

(4) Engage the cylinder rear lug with the curve in rear edge of cradle, and secure with the charger clamp by pulling clamp ring rearwards and then swinging up into horizontal position.

c. DISMOUNTING CHARGER. (1) Disengage charger clamp from cylinder rear lug by pulling the clamp ring to the rear and swinging it down.

(2) Pull the charger slightly to the rear, raise rear end, and lift it off the cradle.

102. Disassembly and Assembly

a. DISASSEMBLY. (1) Remove the nut and one washer from the cylinder cap screw.

(2) Hold charger upright on a bench with cylinder cap resting on bench (fig. 190).



RA PD 94061

Figure 190. Disassembly of 20-mm hydraulic charger M5.

(3) Press down on charger and remove the cap screw and washer, taking care not to let the piston return spring fly out (fig. 190).

(4) Gradually loosen the hold on the charger, taking care not to let the spring fly out.

(5) Remove the cylinder cap, spring guide and driving lug retaining assembly, return spring, latch operating assembly, driving lug assembly, and piston assembly (fig. 191).

(6) To disassemble the spring guide and driving lug retaining assembly, proceed as follows:

(a) Remove the buffer (fig. 192).

(b) Drive out the two pins and remove the driving lug latches.

(7) To disassemble the latch operating assembly, proceed as follows:

(a) Unscrew the latch locking head from the locking plunger. If necessary, pry the latch locking detent off the head (fig. 193).

(b) To remove the plunger and spring retainer from the plunger guide, drive out the pin from the guide (fig. 193).

(8) To disassemble the driving lug assembly, remove the lug detent from the lug (fig. 192).

(9) To disassemble the piston assembly, unscrew the nut and remove the piston seat, the two piston packings, and the piston follower (fig. 194).

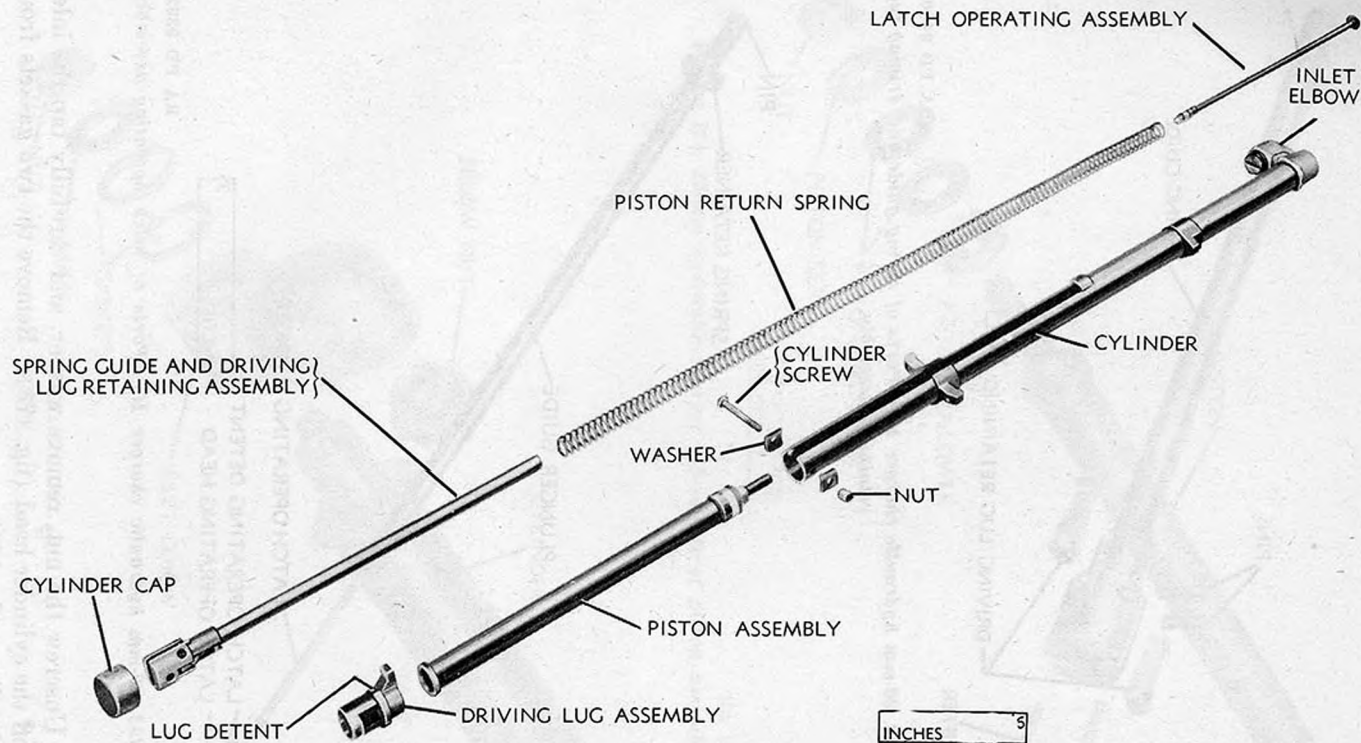
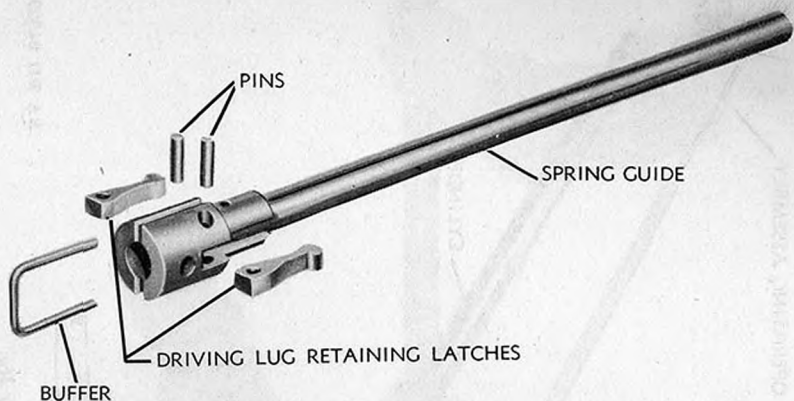

Figure 191. Chief components of 20-mm hydraulic charger M5.

RA PD 94029



RA PD 94006

Figure 192. 20-mm hydraulic charger M5—Parts of spring guide and driving lug retaining assembly.

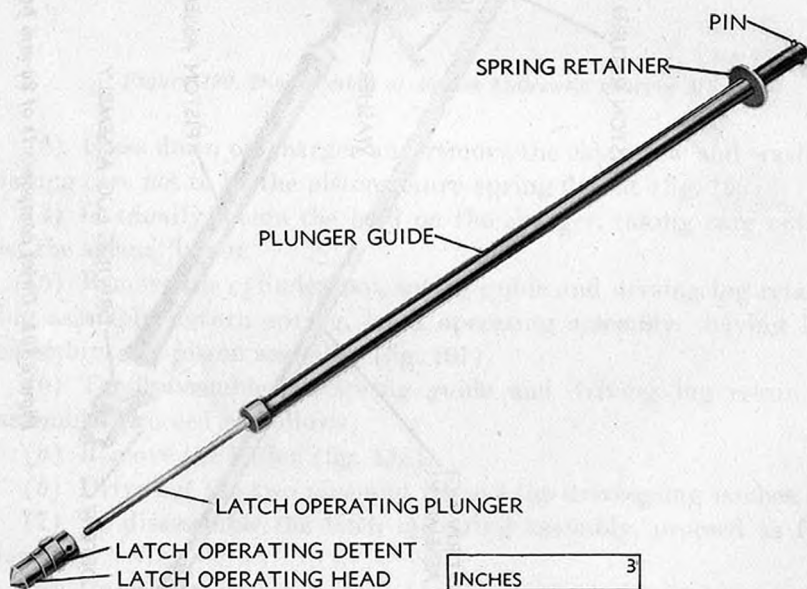

RA PD 93925

Figure 193. 20-mm hydraulic charger M5—Parts of latch operating assembly.

(10) Unscrew the nut, remove washer, and carefully tap the inlet elbow off the cylinder head (fig. 173). Remove the two gaskets from inside the elbow (fig. 195).

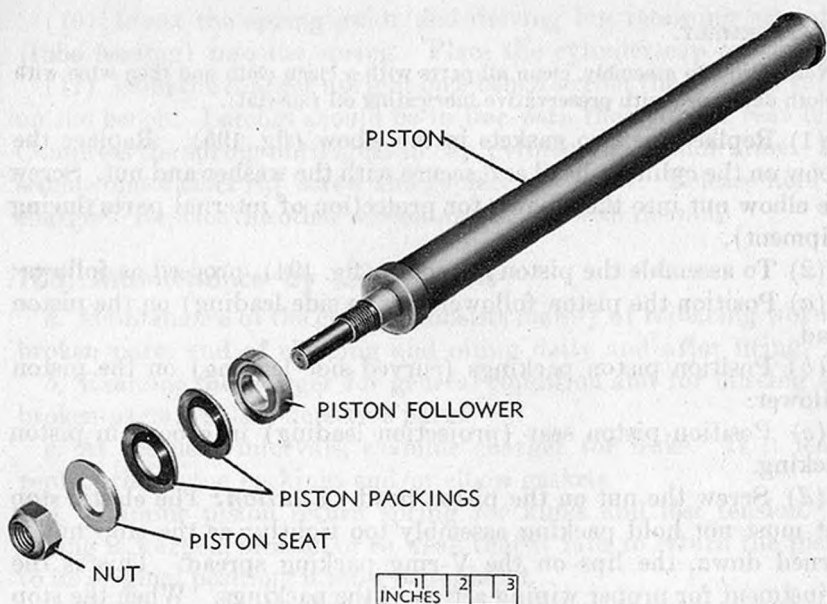

RA PD 93926

Figure 194. 20-mm hydraulic charger M5—Parts of piston assembly.

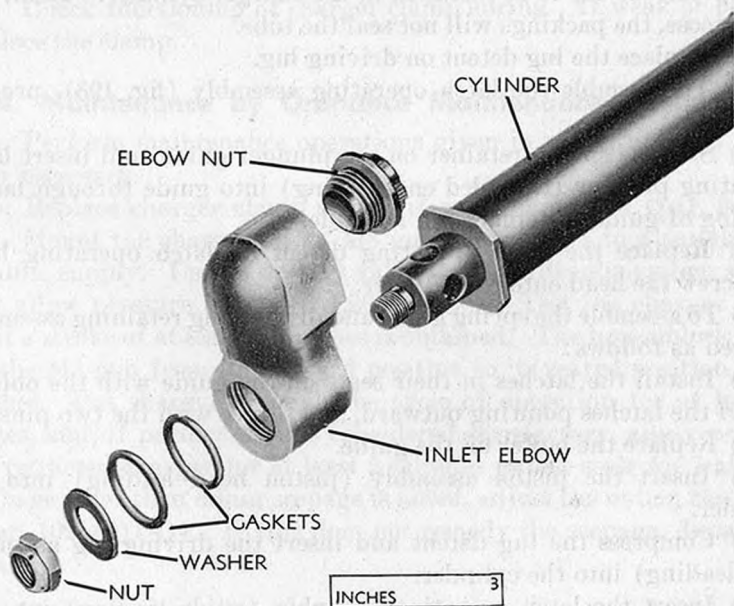

RA PD 93927

Figure 195. 20-mm hydraulic charger M5—Parts of inlet elbow.

b. ASSEMBLY.

Note. Prior to assembly, clean all parts with a clean cloth and then wipe with a cloth dampened with preservative lubricating oil (special).

(1) Replace the two gaskets in the elbow (fig. 195). Replace the elbow on the cylinder head and secure with the washer and nut. Screw the elbow nut into the elbow (for protection of internal parts during shipment).

(2) To assemble the piston assembly (fig. 194), proceed as follows:

(a) Position the piston follower (plane side leading) on the piston head.

(b) Position piston packings (curved side leading) on the piston follower.

(c) Position piston seat (projection leading) in groove in piston packing.

(d) Screw the nut on the piston head. **Caution:** The elastic stop nut must not hold packing assembly too tightly; as the stop nut is turned down, the lips on the V-ring packing spread. This is the adjustment for proper wiping action of the packings. When the stop nut is tightened properly, the packing assembly is held tightly enough so that the adapters and packings can be turned on the piston with a medium amount of drag. If the stop nut is too tight, the packings will spread too far to be installed in the charger cylinder. If the nut is too loose, the packings will not seal the tube.

(3) Replace the lug detent on driving lug.

(4) To assemble the latch operating assembly (fig. 193), proceed as follows:

(a) Slip the spring retainer on the plunger guide, and insert latch operating plunger (threaded end leading) into guide through larger opening of guide. Replace pin in guide.

(b) Replace the latch operating detent on latch operating head and screw the head onto the plunger.

(5) To assemble the spring guide and driving lug retaining assembly, proceed as follows:

(a) Install the latches in their seats on the guide with the oblique toes of the latches pointing outward, and secure with the two pins.

(b) Replace the buffer on the guide.

(6) Insert the piston assembly (piston head leading) into the cylinder.

(7) Compress the lug detent and insert the driving lug assembly (lug leading) into the cylinder.

(8) Insert the latch operating assembly (guide leading) into the piston.

(9) Insert the return spring into the piston, making certain that it fits around the latch operating assembly.

(10) Insert the spring guide and driving lug retaining assembly (tube leading) into the spring. Place the cylinder cap on charger.

(11) Hold the charger upright on a bench so that the cylinder cap is on the bench. Latches should be in line with the cylinder rear lugs. Compress the spring until holes in cap, cylinder, and guide align. Assemble one washer cap screw and replace the screw. Release hold on charger. Replace the other washer and secure with the nut.

103. Maintenance by Using Arms

a. Maintenance of the charger consists mainly of replacing worn or broken parts and of cleaning and oiling daily and after firing.

b. Examine the charger for general condition and for missing and broken parts; replace defective parts.

c. At frequent intervals, examine charger for leaks. If it leaks, replace the piston packings and/or elbow gaskets.

d. Examine piston return spring for kinks and lost tension. If spring is warped, broken, or so weak that it fails to return the piston to its original position, it must be replaced.

e. Examine cylinder for dents; check free movement of piston in cylinder. If there is any binding, replace the cylinder.

f. Examine the spring guide, latch operating plunger, and plunger tube for straightness. If bent, replace.

g. Check functioning of charger clamp spring. If weak or broken, replace the clamp.

104. Maintenance by Ordnance Maintenance Personnel

a. Perform maintenance operations given in paragraph 103 whenever necessary.

b. Replace charger clamp spring if weak or broken (par. 94b).

c. Mount the charger on an M3 gun and connect to a suitable hydraulic supply. Use a two-way valve in the hydraulic system and do not allow pressure to exceed 1,200 pounds. Test the charger to see that a stroke of at least $9\frac{1}{4}$ inches is obtained. The breechblock travel of the M3 gun from its forward position to its seared position is $9\frac{1}{8}$ inches. Put charger through the cycle of operation for at least 10 times, and, if performance is considered satisfactory, apply pressure on retracted charger for at least 2 minutes to test seals for leaks. If leakage other than minor seepage is noted, adjust the nut on the piston (par. 102b(2)(d)). If this does not remedy the seepage, discard the charger.

Section XXVII. 20-MM MANUAL CHARGER M6

105. Functioning (Fig. 196)

a. The 20-mm manual charger M6 is a device for charging the 20-mm automatic gun-M3 by hand. Charging is accomplished by pulling the charger cable to the rear until the breechblock is cocked, and then allowing the cable to return by spring action.

b. One end of the charger cable is fixed in position to the rear end plug of the charger while the other end passes through a latch pulley in the plunger assembly and out of the charger over a swivel sheave. Therefore, as the cable is pulled to the rear, it will draw the slide and plunger assemblies to the rear against the resistance of the return spring. When the slide assembly is forced to the rear, the slide latch contacts the lug on the breechblock slide and forces the breechblock to the rear against the force of the driving spring. As the breechblock continues on its rearward movement, it will pass over and depress the sear. The sear, if released, will rise up and engage the breechblock lock when the breechblock starts on its forward movement. The breechblock will thus remain cocked.

c. When the slide and plunger assemblies are pulled to the rear, the end of the catch cable, which is fixed to the plunger assembly, will also move and, as a result, the return spring will be compressed. When the gun is charged and the charger cable is released, the force of the return spring will cause the operating parts to return to their original position.

106. Installation and Removal

a. ADJUSTING CHARGER FOR RIGHT-HAND OR LEFT-HAND CHARGING. Determine whether or not the charger is to be installed for left-hand or right-hand charging. If necessary, adjust for either left-hand or right-hand charging as follows:

(1) Unscrew the bracket screws and reposition the cradle mounting bracket 180 degrees, and secure it with the two screws (fig. 197).

(2) When properly adjusted, the yoke of the bracket will point down when the driving lug is adjacent to the side of the gun on which the charger is to be installed (fig. 197).

b. MOUNTING CHARGER. (1) Install the charger clamp on the rear end of the cradle (par. 91*b*(2)).

(2) Place the charger on edge of cradle so that arms of cradle mounting bracket fit over side of cradle, while toe of mounting lug on jacket fits into the seat in rear of cradle. Pull clamp ring rearwards and swing up into horizontal position. Release ring so that plunger fits into seat in lug of jacket.

(3) Secure the mounting bracket to the cradle by means of the bracket screw and lock-wire the screw (fig. 198).

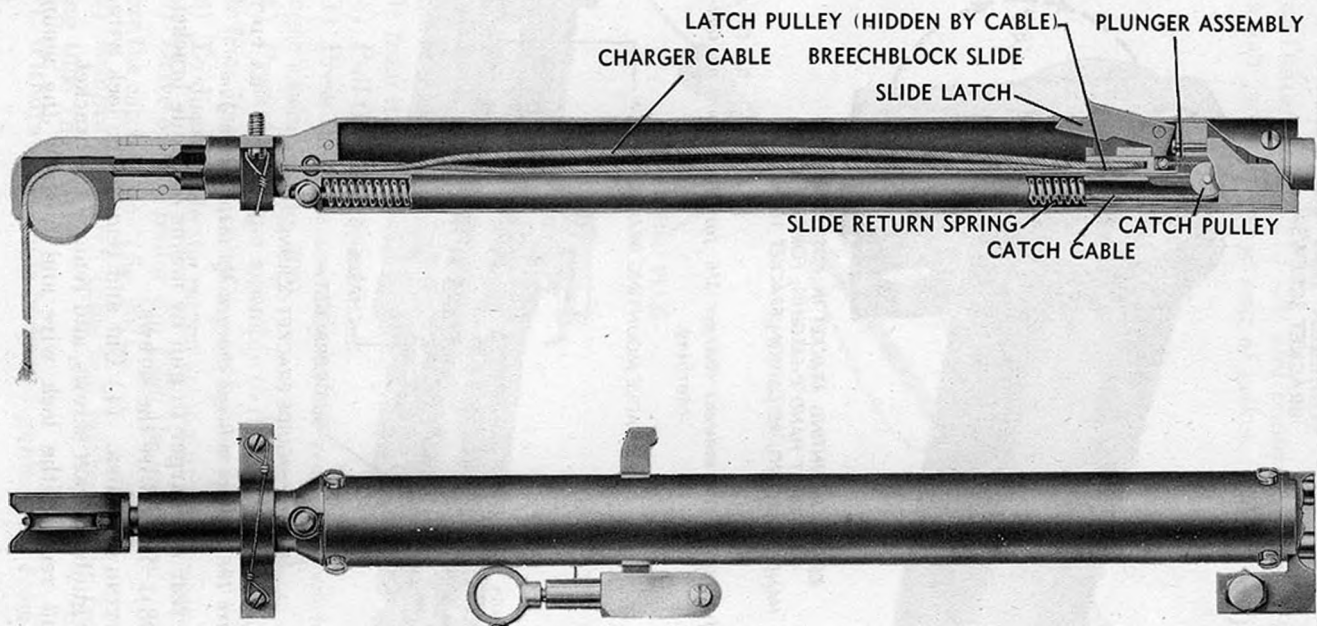
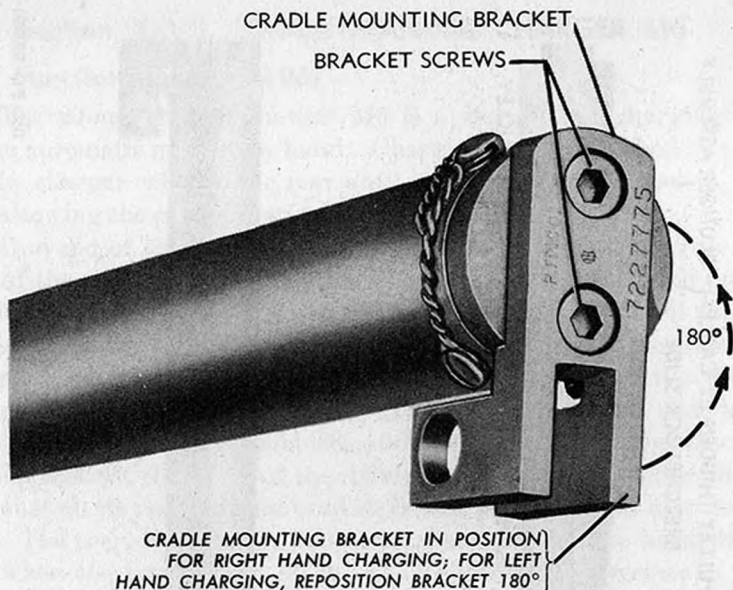

Figure 196. Function of 20-mm manual charger M6.

RA PD 93960



RA PD 93967

Figure 197. Adjusting 20-mm manual charger M6 for right-hand or left-hand charging.

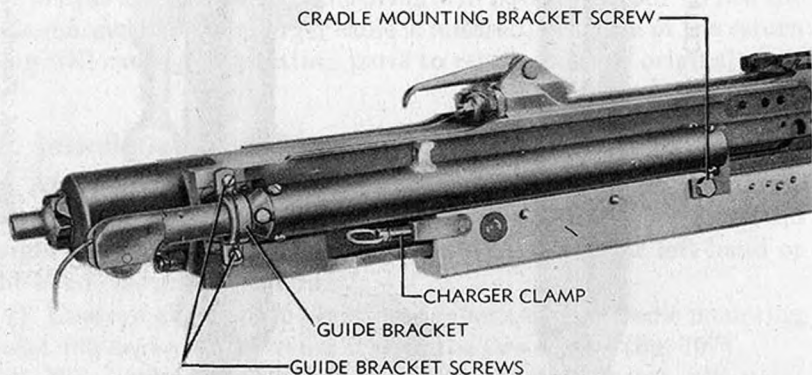

RA PD 108034

Figure 198. 20-mm manual charger M6 installed on gun.

(4) Secure rear of charger to gun by means of guide bracket and screws (fig. 198). Lock-wire the screws.

c. DISMOUNTING CHARGER. (1) Cut and remove the lock wire, unscrew the two guide bracket screws, and remove the bracket.

(2) Cut and remove the lock wire and unscrew the mounting bracket screw.

(3) Pull the clamp ring rearwards and swing it down so that the plunger is disengaged from the mounting lug of the jacket.

(4) Raise the rear of the charger and lift it off the cradle.

107. Disassembly and Assembly

a. **DISASSEMBLY.** (1) Cut and remove the lock wire and unscrew the four jacket screws at rear of jacket. Pull off the jacket (fig. 199).

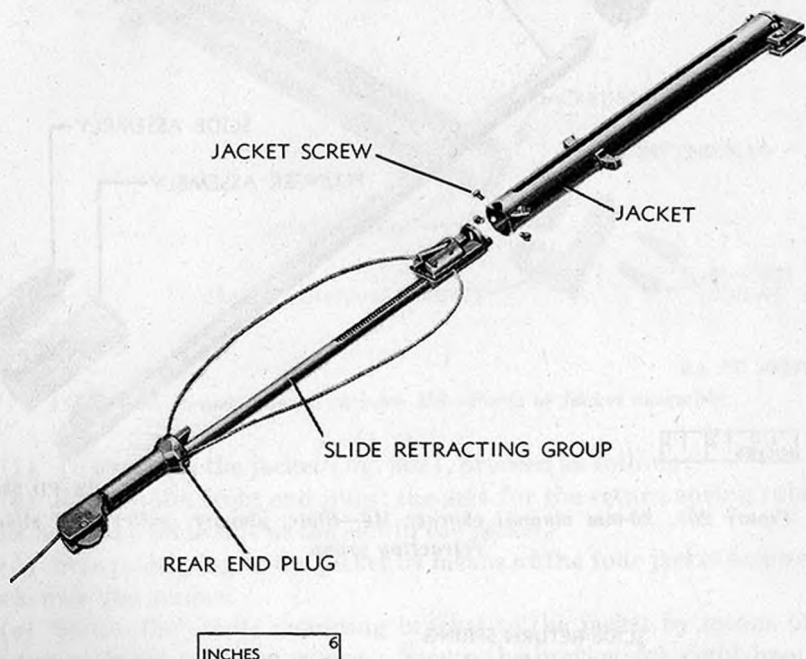

RA PD 108030

Figure 199. Chief components of 20-mm manual charger M6.

(2) Disengage the connector fitting on charger cable from its seat in the rear end plug (fig. 199). Disengage connector fitting on catch cable from its seat in the rear end plug (fig. 200).

(3) Pull the charger cable out.

(4) Press the slide assembly to the rear and remove it from the plunger assembly (fig. 200).

(5) Press the plunger assembly to the rear and disengage the catch cable from its seat in the plunger (fig. 200).

(6) To disassemble the return spring group, proceed as follows:

(a) Drive out the pulley pin from the guide body, taking care not to lose the catch pulley (fig. 201).

(b) Remove the catch cable and return spring from the return spring tube (fig. 201).

(c) Withdraw the guide body and guide shaft from the tube (fig. 201).

(7) To disassemble the jacket, proceed as follows:

(a) Unscrew the two cradle mounting bracket screws and remove the bracket from the jacket (fig. 202).

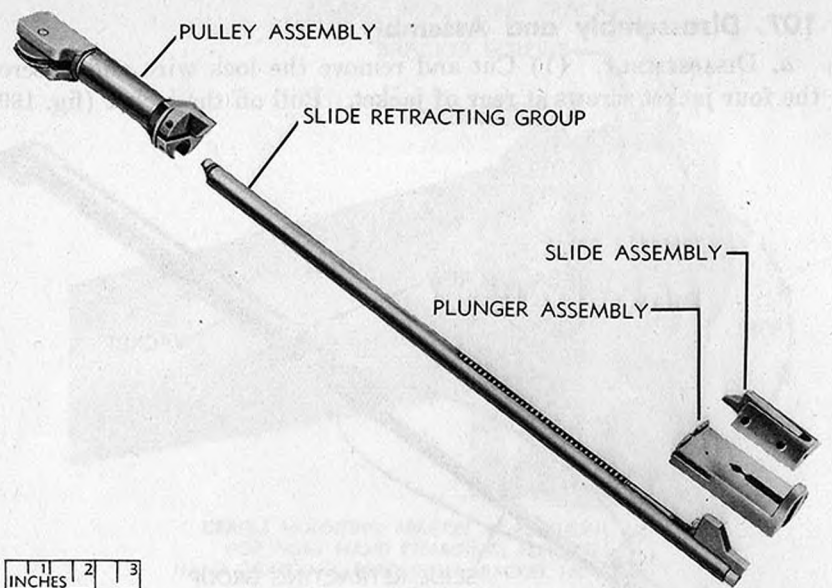

RA PD 93940

Figure 200. 20-mm manual charger M6—Slide, plunger, pulley, and slide retracting group.

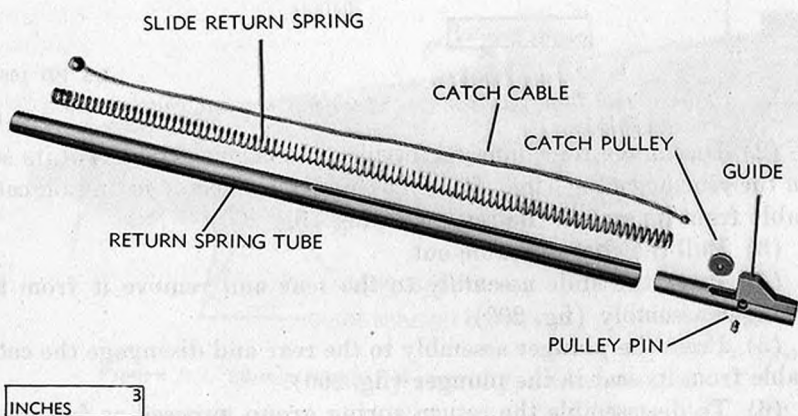

RA PD 108036

Figure 201. 20-mm manual charger M6—Parts of slide operating group.

(b) Cut and remove the lock wire, unscrew the four jacket screws, and drive the front end plug out of the jacket (fig. 202).

b. ASSEMBLY.

Note. Prior to assembly, clean all parts with a clean cloth and wipe with a cloth dampened with preservative lubricating oil (special).

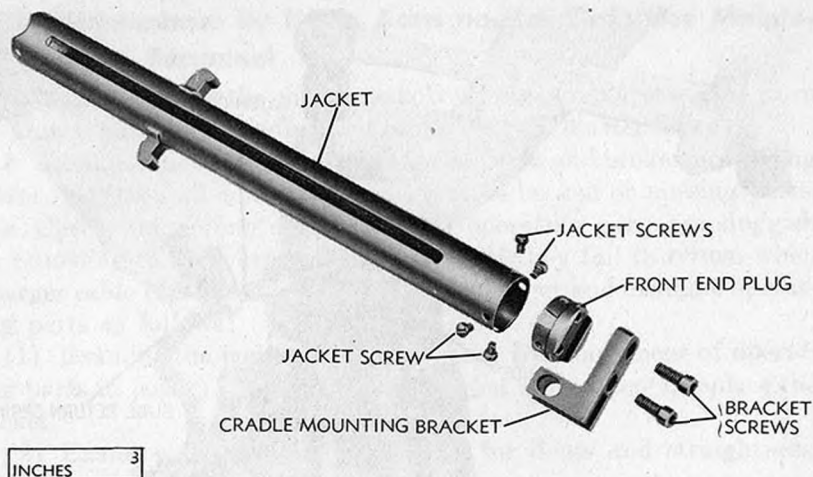

RA PD 93945

Figure 202. 20-mm manual-charger M6—Parts of jacket assembly.

(1) To assemble the jacket (fig. 202), proceed as follows:

(a) Replace the front end plug; the seat for the return spring tube must be on the same side as the slot in the jacket.

(b) Secure the plug to the jacket by means of the four jacket screws. Lock-wire the screws.

(c) Secure the cradle mounting bracket to the jacket by means of the two mounting bracket screws. Secure the bracket for right-hand or left-hand charging as desired (par. 106a).

(2) To assemble the return spring group (fig. 201), proceed as follows:

(a) Insert catch cable into return spring.

(b) Compress return spring and hold it in compression by gripping cable with pliers as shown in figure 203.

(c) Pass small connector fitting of cable into guide and out through the slot in the guide (fig. 203).

(d) Grasp and hold the small connector fitting of the cable around the groove of the catch pulley, and secure the pulley to the guide by means of the pulley pin.

(e) Install spring, cable, and catch assembly into the tube and compress the opposite end of the cable with pliers to enable the connector fitting of cable to seat in the pulley assembly (fig. 204). Tap the tube assembly firmly in place. Make sure alignment of tube and pulley assembly is correct.

(3) Assemble the plunger assembly on the return spring tube so that guide fits into slot in plunger (fig. 200). Pull the small connector fitting of cable up through the slot in plunger assembly and seat it in its seat in the plunger assembly.

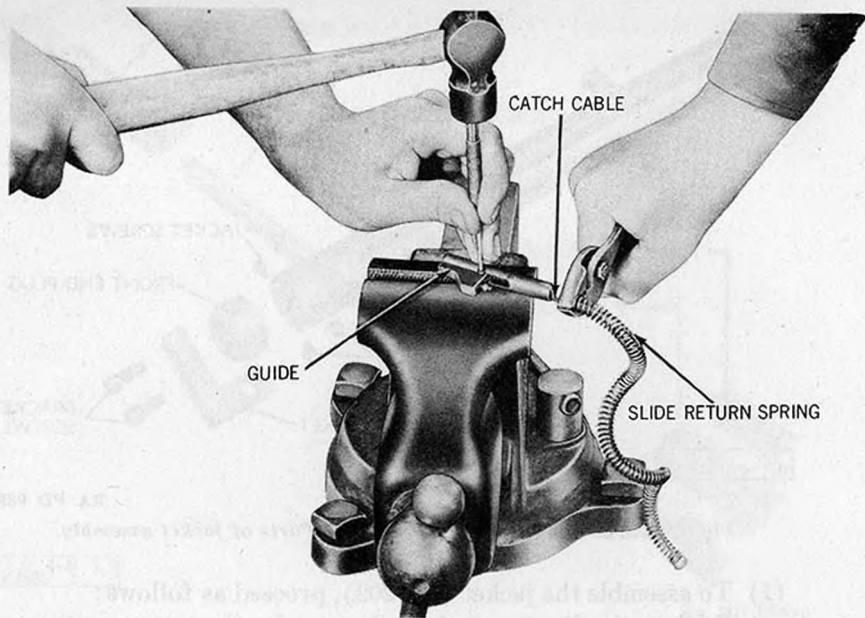

RA PD 111092

Figure 203. Assembling of slide operating group.

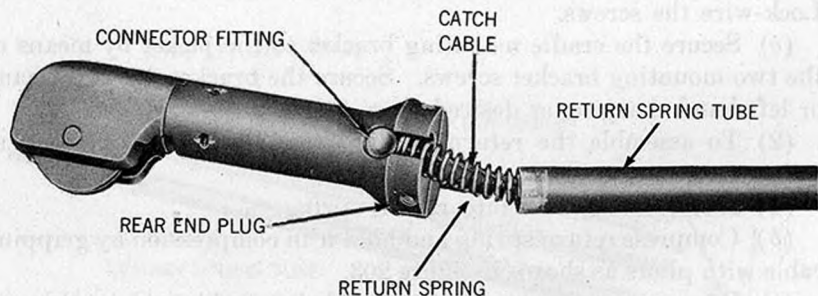

RA PD 110933

Figure 204. Assembling slide operating group to pulley assembly.

(4) Press the slide assembly against the guide and position the slide on the plunger assembly with the slide latch pointing away from plunger (fig. 200).

(5) Pass the long cable around the latch pulley in the plunger connector fitting (on left side).

(6) Position connector fitting of charger cable and catch cable in seats of rear end plug; pass free end of charger cable through plug and around sheave.

(7) Slide assembled unit into jacket (latch on side of slot), replace four screws, and secure with lock wire.

108. Maintenance by Using Arms and/or Ordnance Maintenance Personnel

a. Maintenance of the charger involves mostly replacement of worn or broken parts and cleaning and oiling daily and after firing.

b. Examine the charger for general condition and broken or missing parts. Tighten all connections and replace broken or missing parts.

c. Check functioning of charger. If operating parts are sluggish in returning to their original position or if they fail to return when charger cable is released, disassemble the charger and examine operating parts as follows:

(1) Examine the jacket for dents; check free movement of operating parts in jacket. If parts bind in jacket due to dents, replace the jacket.

(2) Examine the return spring tube for dents and straightness. If bent or dented, replace the tube.

(3) If return spring is warped or broken, replace it.

(4) If the slide latch fails to engage the breechlock slide when the charger cable is pulled to the rear, it is due to a broken latch plunger which must be replaced.

(5) Check functioning of charger clamp spring. If weak or broken, replace the clamp.

(6) Replace charger clamp spring if weak or broken (par. 94*b*) (ordnance maintenance personnel only).

Section XXVIII. 20-MM ELECTRIC TRIGGER AN-M1A1

109. General

a. The 20-mm electric trigger AN-M1A1 (fig. 205) is a remote control device designed to fire the 20-mm automatic gun M3 in airplanes that are equipped with 24-volt electrical systems. The trigger is attached to the receiver plate of the gun. It consists essentially of the sear cover plate assembly and solenoid assembly.

b. The sear cover plate assembly is secured to the bottom of the receiver plate by two lock plates and four cap screws, and provides a means for rapidly mounting and dismounting the electric trigger. The plate incorporates the following:

(1) A solenoid alignment pin which fits into the slotted hole in the base plate of the solenoid body so as to align the sear shaft with the sear of the gun.

(2) A sear spring pin and spring, housed in the solenoid clamping stud and protruding on the inside face of the mounting plate to act on the sear which engages the breechblock lock.

(3) A cam surface on the inside face of the plate just to the rear of the sear spring pin which insures positive engagement of the sear with the breechblock lock by its camming action against the mating

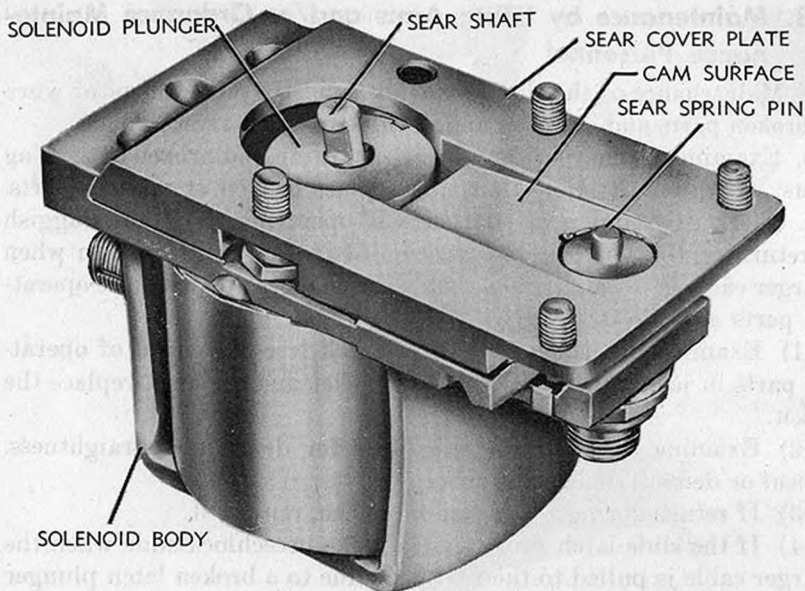

RA PD 94022

Figure 205. 20-mm electric trigger AN-M1A1.

surface of the sear when the sear is forced forward against the sear buffer springs by the breechblock.

c. The solenoid assembly is secured to the plate by means of dovetail connections and the lock mechanism. The solenoid assembly consists of a solenoid mounted on a base plate by a yoke. A plunger and a pinned sear shaft extend through the base plate and are free to move within the solenoid. There is an AN 10066-10S-2P receptacle mounted on the rear end of the yoke for connecting the trigger to the electrical system of the airplane. The solenoid draws a maximum of 8 amperes from a 24-volt system.

d. When the solenoid is energized, a magnetic field is set up which acts on the solenoid plunger and on the attached sear shaft to draw them into the solenoid against spring tension. This force is large enough so that the gun will be fired regardless of the attitude of the plane in which the gun is installed.

110. Installation and Removal

a. **INSTALLATION** (FIGS. 206 AND 207). (1) Secure the sear cover plate to the rear underside of the receiver by means of the two lock plates and the four cap screws. Bend up the tabs of the lock plates to prevent the screws from vibrating loose during firing.

(2) Place the solenoid on the sear cover plate so that the solenoid alignment pin on the plate fits into the slotted hole in the base plate

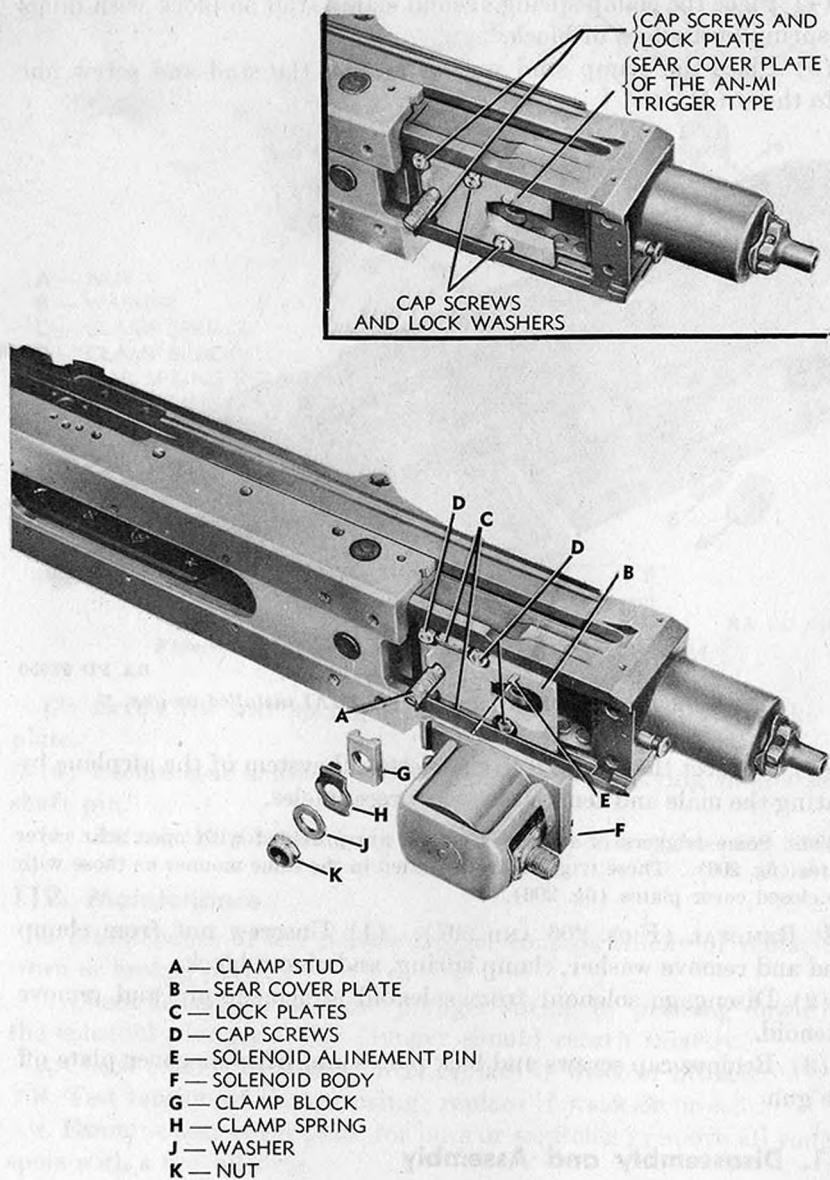

RA PD 93949

Figure 206. Installing 20-mm electric trigger AN-M1A1 on gun.

of the solenoid. Slide the solenoid into position (toward clamp stud).

(3) Place the clamp block on the clamp stud so that the locking shoulders on the block fit over the locking shoulders on the sear cover plate and solenoid.

(4) Place the clamp spring around clamp stud on block with tangs of spring over edges of block.

(5) Place the clamp stud washer around the stud and screw nut onto the stud.

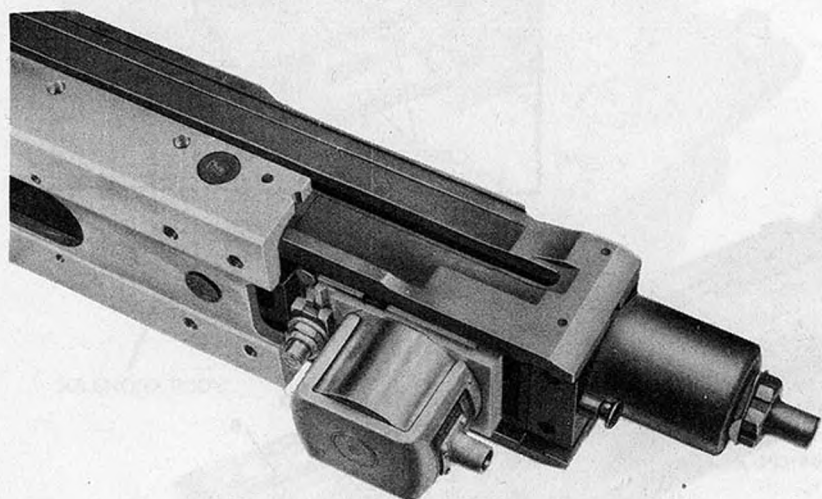

RA PD 93950

Figure 207. 20-mm electric trigger AN-M1A1 installed on gun.

(6) Connect the solenoid to the electrical system of the airplane by mating the male and female electrical receptacles.

Note. Some triggers of the AN-M1 type are provided with open sear cover plates (fig. 206). These triggers are installed in the same manner as those with the closed cover plates (fig. 206).

b. REMOVAL (FIGS. 206 AND 207). (1) Unscrew nut from clamp stud and remove washer, clamp spring, and clamp block.

(2) Disengage solenoid from solenoid alignment pin and remove solenoid.

(3) Remove cap screws and lock plates and lift sear cover plate off the gun.

111. Disassembly and Assembly

a. DISASSEMBLY. (1) Remove solenoid body from sear cover plate (par. 110*b*).

(2) Drive out sear shaft pin and remove sear shaft (fig. 208).

(3) Unscrew the sear spring retainer (fig. 208).

(4) Remove sear spring and sear spring plunger (fig. 208).

b. ASSEMBLY (FIG. 208). (1) Insert sear spring pin (thick end leading) into clamp stud.

(2) Insert sear spring into clamp stud.

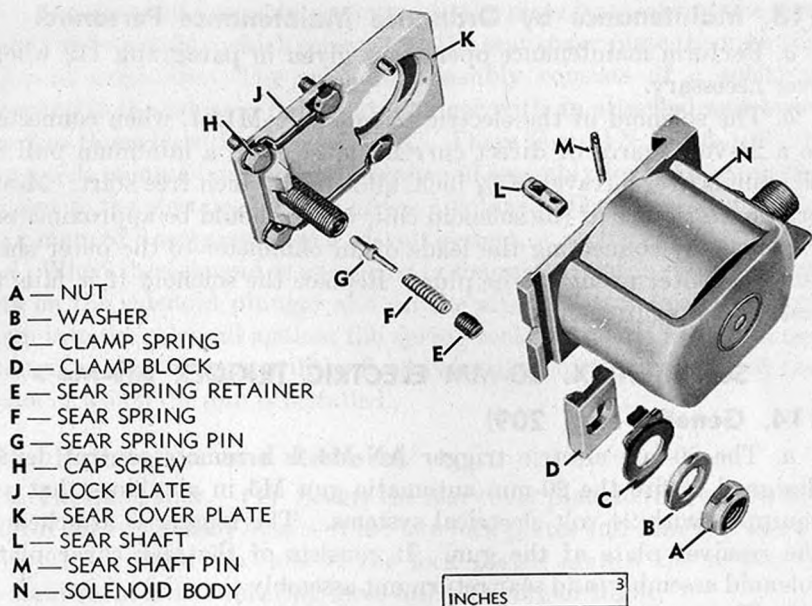

RA PD 94023

Figure 208. Parts of 20-mm electric trigger AN-M1A1.

(3) Screw the sear spring retainer into clamp stud and stake in plate.

(4) Secure sear shaft to solenoid plunger by driving in the sear shaft pin.

(5) Attach the solenoid body to sear cover plate. (See par. 110a.)

112. Maintenance

a. Maintenance of the electric trigger consists chiefly of replacing worn or broken parts.

b. Check tension of solenoid plunger spring by pressing down on the solenoid plunger. The plunger should return smartly.

c. Check tension of sear spring; replace if weak or broken.

d. Test tension of clamp spring; replace if weak or broken.

e. Examine sear cover plate for burrs or scratches; remove all rough spots with a fine oilstone.

f. Check for looseness of solenoid alignment pin and solenoid clamp-stud; if loose, replace sear cover plate.

g. Check functioning of solenoid body by energizing it from a 24-volt source. If it trips the sear of a serviceable gun satisfactorily, it can be considered serviceable.

113. Maintenance by Ordnance Maintenance Personnel

a. Perform maintenance operations given in paragraph 112 whenever necessary.

b. The solenoid of the electric trigger AN-M1A1, when connected to a 24-volt source of direct current, must exert a minimum pull of 68 pounds over a travel of $\frac{1}{4}$ inch, allowing $\frac{1}{16}$ inch free start. Measure the resistance of the solenoid coil, which should be approximately 2.5 ohms, by connecting the leads of an ohmmeter to the outer shell and the center prong of the plug. Replace the solenoid if it fails to meet these requirements.

Section XXIX. 20-MM ELECTRIC TRIGGER AN-M4

114. General (Fig. 209)

a. The 20-mm electric trigger AN-M4 is a remote control device designed to fire the 20-mm automatic gun M3 in airplanes that are equipped with 24-volt electrical systems. The trigger is attached to the receiver plate of the gun. It consists of the sear cover plate, solenoid assembly, and sear return nut assembly.

b. The sear cover plate is secured to the bottom of the receiver plate by two lock plates and four cap screws and provides a means for rapid mounting and dismounting of the trigger. A cam surface on the inside face of the plate, just to the rear of the sear spring pin, insures positive engagement of the sear with the breechblock lock by its camming action against the mating surface of the sear, when the sear is forced against the sear buffer springs by the breechblock.

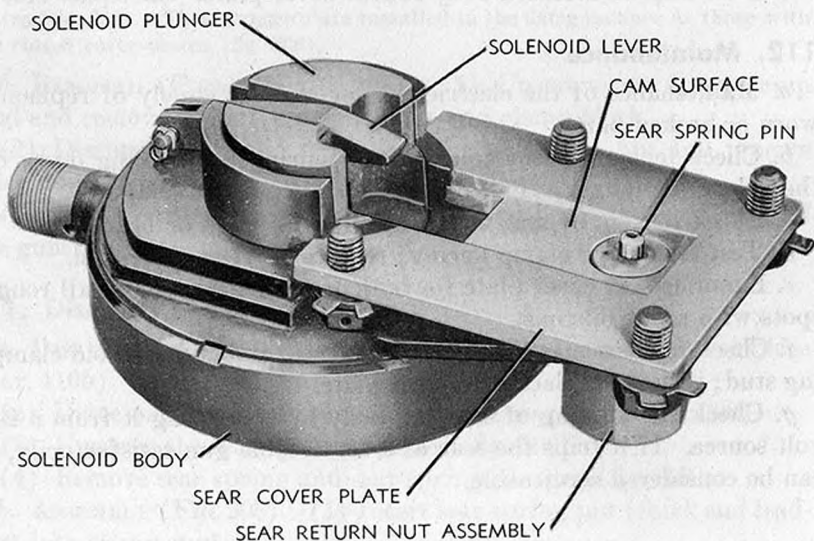

RA PD 94024

Figure 209. 20-mm electric trigger AN-M4.

c. The solenoid assembly is secured to the plate by means of the sear return nut assembly which screws into the sear cover plate through the solenoid armature. The solenoid assembly consists of a solenoid mounted in the solenoid body. A plunger with an attached sear lever are free to move within the solenoid. There is an AN 10066-10S-2P receptacle mounted on rear end of solenoid assembly for connecting the trigger to the electrical system of the airplane. The solenoid draws a maximum of 8 amperes from a 24-volt system.

d. When the solenoid is energized, a magnetic field is set up which acts on the solenoid plunger and on the attached sear lever to draw them into the solenoid against the spring tension. This force is large enough so that the gun will be fired regardless of the attitude of the plane in which the gun is installed.

115. Installation and Removal

a. **INSTALLATION.** (1) Secure the sear cover plate to the rear underside of the receiver by means of the two lock plates and four cap screws (fig. 210). Bend the tabs of the lock plates against the screws to prevent them from vibrating loose during firing or flight.



RA PD 93951

Figure 210. Installing 20-mm electric trigger AN-M4 on gun.

(2) Place the solenoid assembly on the sear cover plate so that the solenoid lever engages the sear and the hole in the armature aligns with the threaded hole in the sear cover plate (fig. 210).

(3) Secure the solenoid to the sear cover plate by screwing in the sear return nut assembly (fig. 211). Lock-wire the nut to the armature on the solenoid.

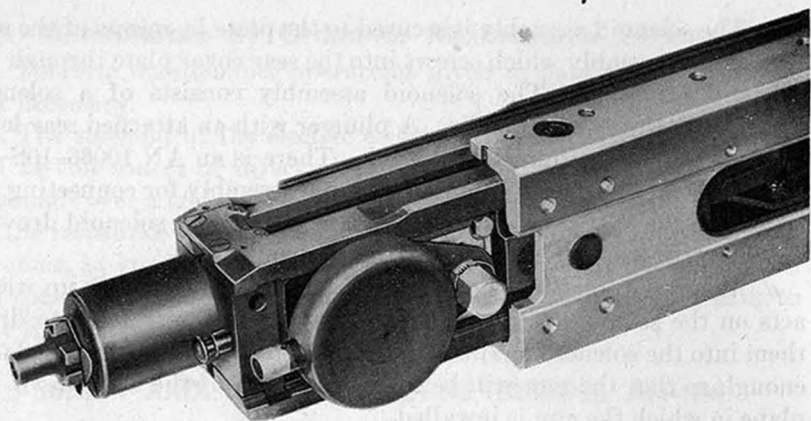

RA PD 93952

Figure 211. 20-mm electric trigger AN-M4 installed on gun.

(4) Connect the solenoid to the electrical system of the airplane by mating the male and female electrical receptacles.

b. REMOVAL (FIGS. 210 AND 211). (1) Cut and pull out the lock wire and unscrew the sear return nut assembly.

(2) Remove the solenoid assembly.

(3) Straighten the tabs on lock plates, remove plates, and unscrew the cap screw.

(4) Remove sear cover plate.

116. Disassembly and Assembly

a. DISASSEMBLY. (1) Remove sear return nut and solenoid assemblies from sear cover plate. (See par. 115*b*.)

(2) Remove cotter pin and pull out sear lever pin (fig. 212).

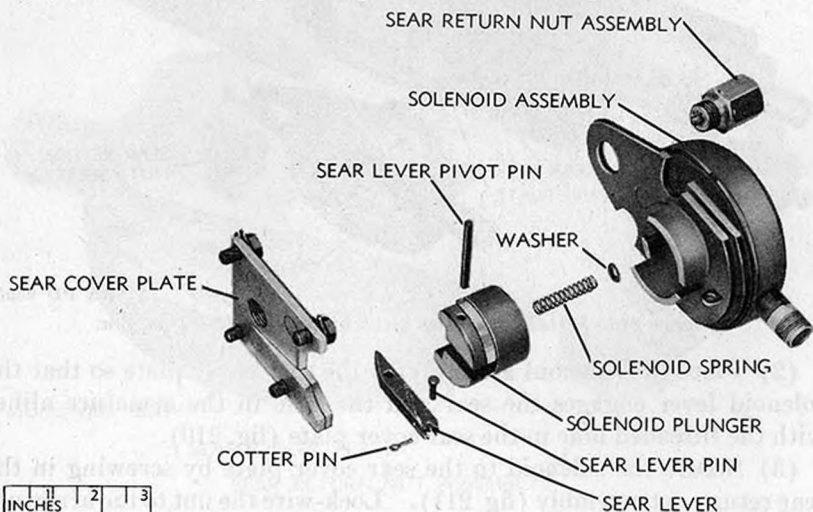

RA PD 94025

Figure 212. Parts of 20-mm electric trigger AN-M4.

(3) Drift out the sear lever pivot pin from the solenoid plunger (fig. 212).

(4) Remove solenoid spring and washer (fig. 212).

b. ASSEMBLY (FIGS. 212 AND 209). (1) Replace washer in solenoid and follow with solenoid spring.

(2) Secure sear lever to solenoid plunger by means of sear lever pivot pin. The angle surface of lever should be up and toward cut-out part of plunger.

(3) Press down plunger into solenoid over spring slotted end of lever engaging boss on solenoid body.

(4) Secure the lever to the boss by means of the lever pin and cotter pin.

(5) Attach solenoid assembly and sear return nut assembly to the sear cover plate. (See par. 115*a.*)

117. Maintenance by Using Arms

a. Maintenance of the electric trigger consists chiefly of replacing worn or broken parts.

b. Check tension of solenoid plunger spring by pressing down on the solenoid plunger; the plunger should return smartly.

c. Check tension of sear spring by pressing down sear spring pin.

d. Examine sear cover plate for burrs and scratches; remove all rough spots with a fine oilstone.

e. Check functioning of solenoid by energizing it from a 24-volt source. If it trips the sear of a serviceable gun satisfactorily, it can be considered serviceable.

118. Maintenance by Ordnance Maintenance Personnel

a. Perform maintenance operations given in paragraph 117 whenever necessary.

b. The solenoid of the electric trigger AN-M4 when connected to a 24-volt source of direct current, must exert a minimum pull of 68 pounds over a travel of $\frac{1}{4}$ -inch, and should have at least a $\frac{3}{8}$ -inch stroke. Measure the resistance of the solenoid coil, which should be approximately 2 ohms, by connecting the leads of an ohmmeter to the outer shell and the center prong of the plug. Replace the solenoid if it fails to meet these requirements.

Section XXX. 20-MM ELECTRIC HEATER M1

119. General

The 20-mm electric heater M1 (fig. 213) is of the resistance type and is designed to enable the gun to operate at ambient temperatures as low as -65° F. The heater consists of three heating units in series and is rated at 200 watts, using 24-volt direct current.

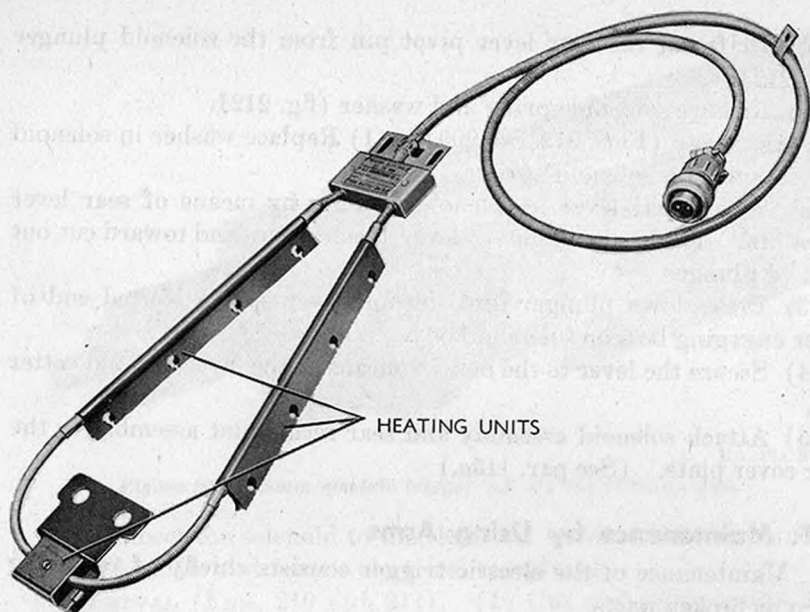

RA PD 94059

Figure 213. 20-mm electric heater M1.

120. Installation and Removal

a. INSTALLATION (FIGS. 214 AND 215). (1) Remove the cradle. (See par. 60*a*.)

(2) Remove the cradle mounting plate by straightening tabs of lock plates, unscrewing mounting plate screws, and removing lock plates (fig. 214).

(3) Cut and remove the lock wire, unscrew the two breechblock locking plate screws, and remove the two washers and the locking plate (fig. 214).

(4) Remove the cotter pins, unscrew the receiver slide bolt nuts, and remove the washers from both receiver slides (fig. 214).

(5) Install the middle heating unit on the breechblock locking key, replace the locking key plate, and secure with the two washers and screws. Lock-wire the screws (fig. 215).

(6) Install the other two heating units on the receiver slide bolts and secure with the nuts and cotter pins (fig. 215).

(7) Secure the front plate to the receiver by means of two screws and lock-wire the screws.

(8) Install the cradle mounting plate and then the cradle. (See par. 60*b*.)

b. REMOVAL (FIG. 215). (1) Remove the cradle. (See par. 60*a*.)

(2) Remove the cradle mounting plate. (See *a*(2) above.)

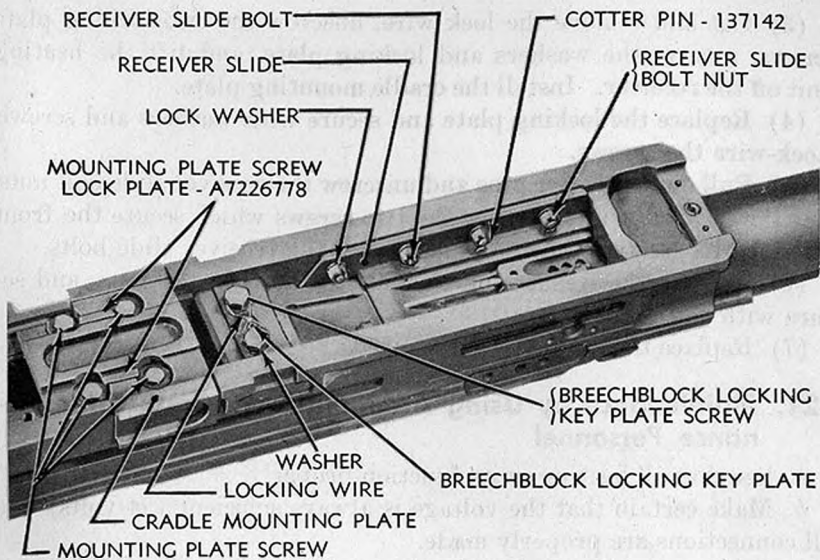

RA PD 108075

Figure 214. Removal of gun parts prior to installing 20-mm electric heater M1.

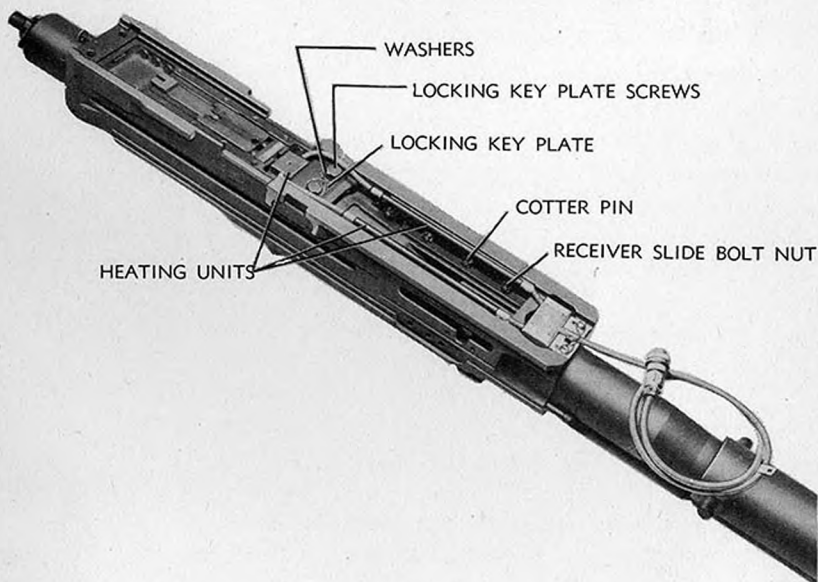

RA PD 93948

Figure 215. 20-mm electric heater M1 installed on gun.

(3) Cut and remove the lock wire, unscrew the two locking plate screws, remove the washers and locking plate, and lift the heating unit off the receiver. Install the cradle mounting plate.

(4) Replace the locking plate and secure with washers and screws. Lock-wire the screws.

(5) Pull out the cotter pins and unscrew the receiver slide bolt nuts. Cut the lock wire and unscrew the two screws which secure the front plate to the receiver. Lift the heater off the receiver slide bolts.

(6) Replace the washers on the slide bolts, then the nuts, and secure with cotter pins.

(7) Replace the cradle. (See par. 60b.)

121. Maintenance by Using Arms and/or Ordnance Maintenance Personnel

a. See that all heating units function properly.

b. Make certain that the voltage is always sufficient (24 volts) and all connections are properly made.

c. If the voltage is sufficient and the heater fails to heat the gun to operate at ambient temperatures as low as -65° F., the heater should be replaced with a new one.

PART FOUR

AUXILIARY EQUIPMENT

Section XXXI. GENERAL

122. Scope

Part Four contains information pertaining to the operation, functioning, and preventive maintenance of ammunition used in conjunction with the basic weapon.

Section XXXII. AMMUNITION

123. General

The ammunition for 20-mm automatic gun M3 is issued in the form of fuzed complete rounds of fixed ammunition. The term "fixed," when used in connection with ammunition, signifies that the propelling charge is not adjustable and that the round is loaded into the gun as a unit. The propelling charge is assembled loosely in the cartridge case which is crimped rigidly to the projectile. A complete round comprises all the ammunition components used to fire a weapon once. After firing, the cartridge case is extracted and ejected; then the next round is loaded into the gun, all automatically.

124. Firing Tables

Firing tables for aircraft weapons are not printed. They are made up for use in designing sights and are not available for general distribution.

125. Classification

Dependent upon the type of projectile, the ammunition is classified as high-explosive incendiary (HEI), incendiary, armor-piercing with tracer (AP-T), or target practice (TP). The high-explosive-incendiary projectile contains both a high-explosive and an incendiary filler. The incendiary projectile contains an incendiary filler only. The armor-piercing projectile is a solid shot, containing a tracer element for observation of fire, that is, for showing the gunner the path of the projectile in flight. The target practice projectile is inert.

126. Identification

a. GENERAL. Ammunition, including components, is completely identified by means of painting and marking (including ammunition lot number). Other essential information may be obtained from the marking (figs. 217 and 218, and the paragraphs below). Links are shown in figure 216.

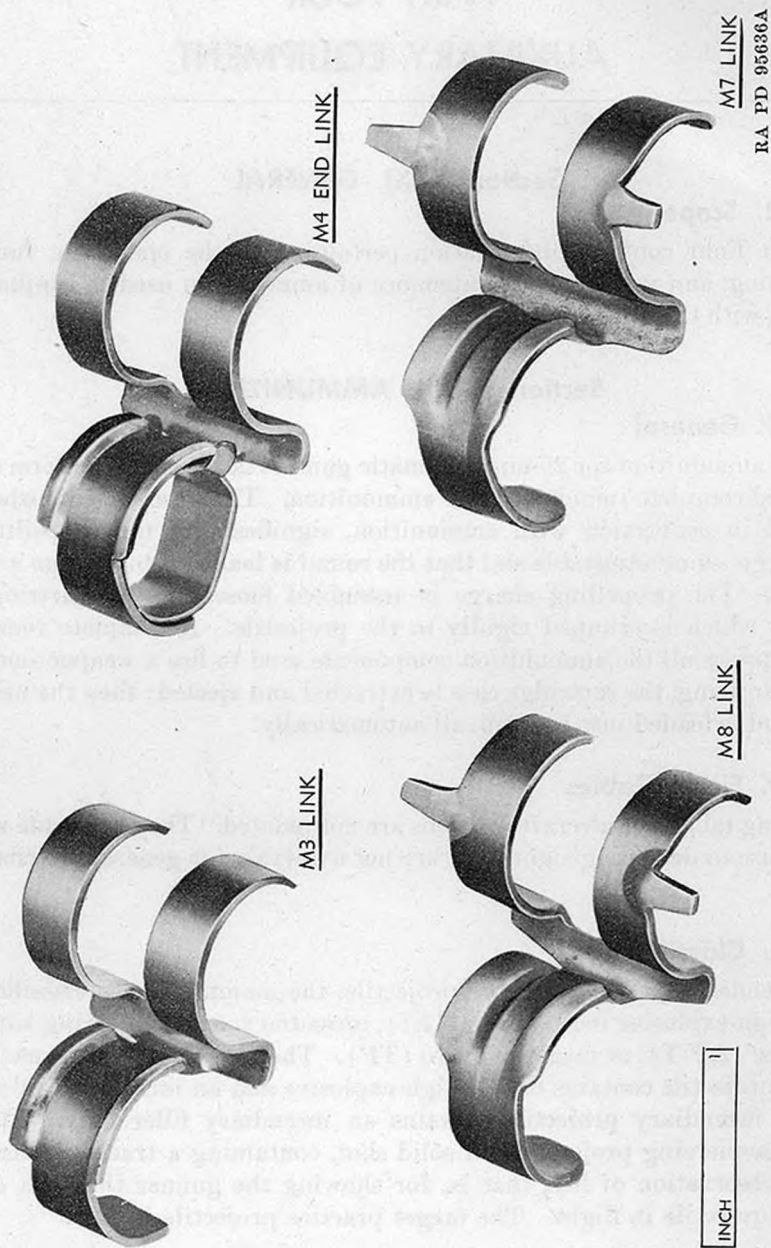
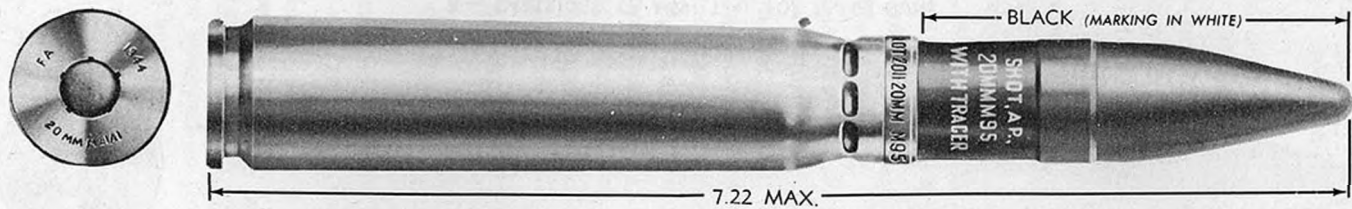
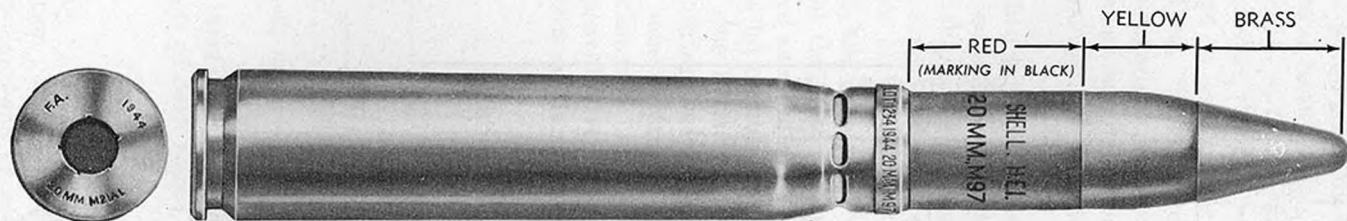

Figure 216. 20-mm links.



A — CARTRIDGE, AP-T, M95 (T9E5), FOR 20-MM GUNS



B — CARTRIDGE, HE-I, M97 (T23), W/FUZE, PD, M75 (T71E4), FOR 20-MM GUNS

Figure 217. 20-mm cartridges.

RA PD 97733

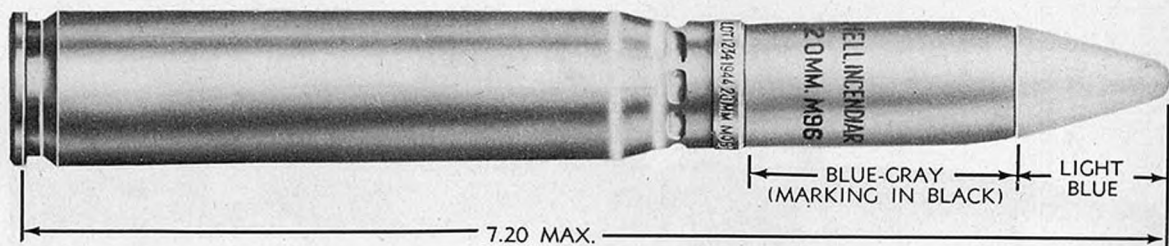

A — CARTRIDGE, INCENDIARY, M96 (T18), FOR 20-MM GUNS

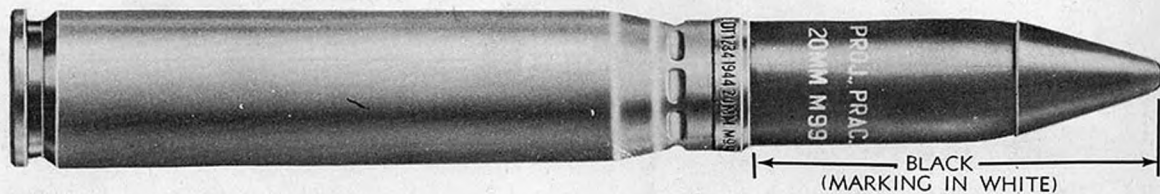

B — CARTRIDGE, TP, M99 (T24), FOR 20-MM GUNS

Figure 218. 20-mm cartridges.

b. **MARK OR MODEL.** To identify a particular design, a model designation is assigned at the time that the design is classified as an adopted type. This model designation becomes an essential part of the standard nomenclature of the item, and is included in the marking of the item. The model designation consists of the letter "M" followed by an arabic numeral. Modifications are indicated by adding the letter "A" and the appropriate arabic numeral. Thus, "M1A1" indicates the first modification of an item for which the original model designation was "M1." Before an item is classified as an adopted type, it is assigned a tentative model designation which consists of the letter "T" followed by an arabic numeral.

c. **AMMUNITION LOT NUMBER.** When ammunition is manufactured, an ammunition lot number, which becomes an essential part of the marking, is assigned in accordance with pertinent specifications. This lot number is stamped or marked on every complete round and on all packing containers. It is required for all purposes of record, including reports on condition, functioning, and accidents in which the ammunition is involved. To provide for the most uniform functioning, all of the rounds of any one lot of fixed ammunition consist of: projectiles of one lot number; fuzes of one lot number; primers of one lot number; and propellant powder of one lot number. Therefore, to obtain the greatest accuracy in any firing, successive rounds should be from the same ammunition lot whenever practicable.

d. **PAINTING AND MARKING.** (1) *Painting.* Projectiles are painted to prevent rust and, by the color, to provide a ready means of identification as to type. The projectiles of the ammunition described herein are painted as follows:

High-explosive-incendiary-----	Yellow ogive; red body, marking in black.
Incendiary-----	Blue ogive; gray body, marking in black.
Armor-piercing-----	Black, marking in white.
Target practice (inert)-----	Black, marking in white.

Note. The above color scheme is not wholly in agreement with the basic color scheme described in TM 9-1900.

(2) *Marking.* For purposes of identification, the following are marked or stamped on the components of each round of ammunition described herein:

- (a) *On projectile (stenciled).*
 1. Kind and type of shell.
 2. Caliber and model designation.
- (b) *On projectile (stamped in rotating band of new rounds).*
 1. Lot number.
 2. Year of manufacture.

3. Manufacturer's initials.
 4. Caliber and model designation.
- (c) *On head of cartridge case.*
1. *Stenciled.*
 - (a) Ammunition lot number.
 - (b) Loader's initials.
 2. *Stamped in metal.*
 - (a) Designation and caliber of case.
 - (b) Manufacturer's initials or symbol.
 - (c) Year of manufacture, in full.
- (d) *On fuze (stamped in metal).*
1. Model and designation of fuze.
 2. Manufacturer's initials or symbol.
 3. Loader's lot number.
 4. Year of loading.

127. Care, Handling, and Preservation

a. Complete rounds are packed to withstand conditions ordinarily encountered in the field. Ammunition for the 20-mm automatic guns is packed in cartons in metal-lined wooden boxes or in metal containers in wooden boxes. Since explosives are adversely affected by moisture and high temperature, the following precautions should be observed:

(1) Do not break moisture-resistant seals until ammunition is to be used.

(2) Protect ammunition, particularly fuzes, from high temperatures, including the direct rays of the sun. More uniform firing is obtained if all the rounds are at the same temperature.

b. *Handle ammunition with care at all times. The explosive elements in primers and fuzes are highly sensitive to shock and high temperature.*

c. Do not attempt to disassemble any complete round or fuze.

d. The complete round should be freed of foreign matter such as sand, mud, grease, etc., just before loading into the magazine or belt. If it gets wet or dirty, it should be wiped dry at once.

e. Although the use of oil or grease on ammunition is generally prohibited, in the case of ammunition for these guns it is necessary to oil the cartridge case in order to prevent jamming. By means of a cloth wrung out of light preservative lubricating oil, spread a light film of oil evenly over the body of the cartridge case just prior to insertion of the round into the magazine or belt. Extreme care should be taken to prevent oil from getting on the primer or joint at the mouth of the cartridge case. Preferably, only one day's supply of ammunition should be lubricated at a time. Rounds oiled for firing and not fired the same day should be wiped dry to prevent the accu-

mulation of dust and grit and the seepage of oil around the primer and mouth of the cartridge case. Such rounds will be used first in subsequent firing; they must be oiled again before use.

f. Do not handle duds. Because their fuzes are armed, duds are extremely dangerous and will be disposed of in accordance with TM 9-1900.

128. Authorized Rounds

The ammunition authorized for use in 20-mm automatic gun M3 is shown in table I. The nomenclature (standard nomenclature) completely identifies the round. The use of standard nomenclature for all purposes of record is mandatory.

129. Preparation for Firing

As issued, the complete rounds are ready for firing after removal of packing; however, it is necessary to oil the rounds as described in paragraph 127e, and to load the rounds into the feed mechanism or the magazine.

130. Description of Rounds

a. GENERAL. The AP-T M95, incendiary M96, HEI M97, and practice M99 have matched ballistics. The shape, length, and weight of these rounds are approximately the same, and all have a purple annulus about the primer at the head of the cartridge case. The trajectories of these rounds meet at 1,000 yards, the time of flight to 1,000 yards for each projectile being approximately 1.66 seconds when fired from a stationary weapon with a muzzle velocity of 2,800 feet per second. The incendiary projectile is slightly lighter in weight than the other projectiles, hence the muzzle velocity of 2,840 feet per second. The complete cartridge weighs approximately 0.57 pound and is 7.2 inches in length.

b. COMPONENTS. Rounds of current manufacture are assembled with—

CASE, cartridge, 20-mm, M21A1; weight: approximately 0.205 pound.

CHARGE, propelling FNH, 20-mm, M1; weight: approximately 0.07 pound.

PRIMER, percussion, M36 or M36A1; weight: 0.003 pound.

PROJECTILE; as described in *a* above, and in paragraph 128.

131. Fuzes

a. GENERAL. A fuze is a mechanical device used with a projectile to explode it at the time, and under the circumstances, desired. A fuze which functions upon impact with a target is classified as the

Table I. Authorized ammunition for 20-mm Automatic Gun M3

Nomenclature	Action of fuze	Approx. weight of projectile as fired (pounds)
<i>Service Ammunition</i>		
CARTRIDGE, AP-T, M95 (T9E5), for 20-mm guns AN-M2 and M3.	None ¹ -----	0. 29
CARTRIDGE, HE I, M97 (T23), w/FUZE, PD, M75, (T71E5), for 20-mm guns AN-M2 and M3.	Superquick-----	0. 29
CARTRIDGE, incendiary, M96 (T18), for 20-mm guns AN-M2 and M3.	None-----	0. 27
<i>Target-practice Ammunition</i>		
CARTRIDGE, TP, M99 (T24), for 20-mm guns AN-M2 and M3.	None-----	0. 29
<i>Drill Ammunition</i>		
CARTRIDGE, drill, M18A1, for 20-mm guns AN-M2 and M3.	None-----	
CARTRIDGE, drill, M18A2, for 20-mm guns AN-M2 and M3.	None-----	
<i>Links ²</i>		
LINK, disintegrating belt, 20-mm, M3 ³ -----	-----	
LINK, disintegrating belt, 20-mm, M3A1 ³ -----	-----	
LINK, disintegrating belt, 20-mm, M7 ⁴ -----	-----	
LINK, disintegrating belt, 20-mm, M8 ⁴ -----	-----	
LINK, end, disintegrating belt, 20-mm, M4 ³ -----	-----	
LINK, end, disintegrating belt, 20-mm, M5 (alternative). ³	-----	

AP-T—armor-piercing, with tracer.

HEI—high-explosive-incendiary.

TP—target practice.

¹ Length of trace is about 1,270 yards.² Length of a 20-round linked belt is 28¼ inches.³ For use with feed mechanism M3.⁴ For use with feed mechanisms AN-M2 and M3.

impact type. Fuzes which function on impact with a light material target, such as an airplane wing, are further classified as supersensitive fuzes.

Caution: Fuzes will not be disassembled. Any attempt to disassemble fuzes in the field is dangerous and is prohibited except under specific direction of the Chief of Ordnance.

b. FUZE, PD, M75 (T71E5). This is an instantaneous percussion fuze of the impact type which can penetrate light armor and function on heavier armor of aircraft. Like some fuzes used with small-

caliber ammunition, this fuze does not come within the definition of boresafe. It is used with 20-mm aircraft ammunition and is issued assembled to the high-explosive incendiary projectile.

132. Packing and Marking

a. PACKING. Rounds of 20-mm caliber are packed 10 rounds per fiber carton, 12 cartons (120 rounds) per sealed metal-lined packing box (fig. 219). Recent packings are 25 rounds in a metal container, 6 containers (150 rounds) in a wooden box. The following data are considered suitable for estimating weight and volume requirements:

	<i>Weight</i> (pounds)	<i>Volume</i> (cubic feet)
Complete round, without packing material----	0.57	---
120 rounds in 10-round fiber cartons in metal-lined packing box-----	95	1.5
150 rounds in 25-round metal containers in wooden packing box-----	106	1.5
150 incendiary M96 rounds in 25-round metal containers in wooden packing box-----	103	1.5
Over-all dimensions of packing boxes (inches) : $18\frac{1}{4} \times 13\frac{3}{8} \times 10\frac{3}{4}$		

b. MARKING FOR SHIPMENT. (1) Packings for shipment are marked as follows (fig. 219) :

(*a*) Name and address of consignee (or code marking), preceded by the word "To."*

(*b*) Name and address of ultimate consignee, preceded by the word "For."*

(*c*) List and description of contents.

(*d*) Ammunition code symbol (AIC) as published in ORD 11 SNL R-1.

(*e*) Gross weight in pounds; displacement in cubic feet.

(*f*) The number of the package or shipping ticket.*

(*g*) The letters "U. S." in several conspicuous places.

(*h*) Order number, contract number, or shipping number.

(*i*) Ordnance insignium and escutcheon.

(*j*) Name or designation of consignor preceded by the word "From."*

(*k*) Lot number.

(*l*) Month and year packed.

(*m*) Inspector's stamp.

(2) The letter "T" stenciled on the box indicates that the projectile contains a tracer.

(3) A blue stripe painted around the packing box indicates that the box contains practice ammunition.

*May be omitted on individual package in carload shipments provided shipments consist of standard weights and dimensions containing standard quantities.

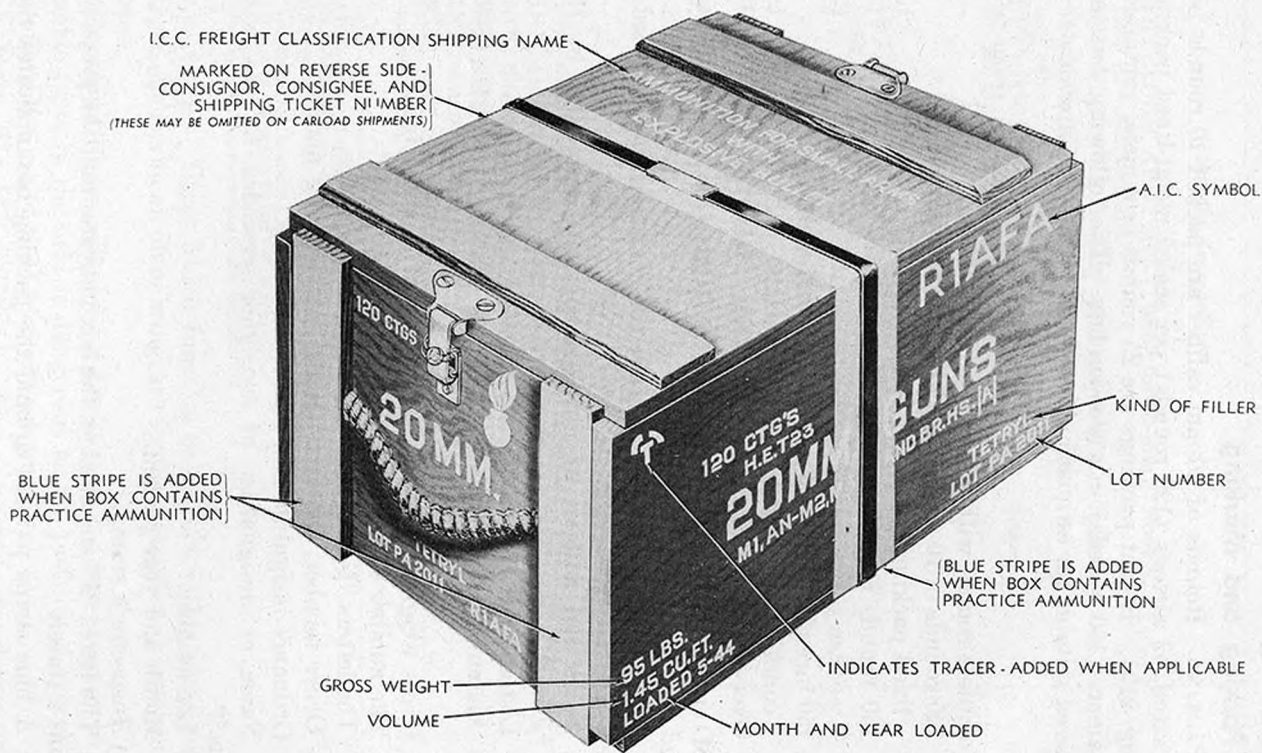

Figure 219. Packing box for ammunition for 20-mm guns.

APPENDIX I

STORAGE AND SHIPMENT

1. Preparation of Matériel

a. MATERIALS REQUIRED. The required materials listed for preparation of gun are in addition to those listed in section IX.

ACID, phosphoric, metal conditioner, concentrated, wipe-off type, type II.

BARRIER, waterproof.

CLOTH, abrasive, aluminum-oxide.

COMPOUND, sealing, tape.

PAPER, flint (sandpaper), grade 0 to grade 3.

SOAP, issue.

TAPE, adhesive, nonhygroscopic, O. D.

WRAPPING, greaseproof (type I, grade C).

b. CLEANING. Prior to the application of preservatives, thoroughly clean the gun as described below.

(1) *Cautions.* (a) Give special attention to bearing surfaces, revolving parts, springs, and screw threads, as well as the interior of the breechblock and the bore of the gun.

(b) Do not use dry-cleaning solvent to clean the bore of the gun.

(c) Make the partial disassembly of the breechblock in accordance with the procedure outlined in section XIX.

(d) Dry all surfaces thoroughly with clean dry cloths and handle carefully to avoid contact with bare hands.

(2) *Cleaning nonrusted surfaces.* (a) *Rifle-bore cleaner* is used for cleaning matériel with the exception of feed mechanism. The standard bore brushes and cleaning equipment supplied with matériel are satisfactory for cleaning.

(b) *Dry cleaning solvent* is used for cleaning the feed mechanism. Apply drycleaning solvent by scrubbing with a brush or wiping with a clean saturated cloth. Repeat application with clean solvent and cloths until all traces of foreign matter have been removed.

(3) *Cleaning rusted surfaces.* Clean all metal surfaces that have become rusted or pitted as follows:

(a) *Unpainted metal surfaces.*

1. Use crocus cloth for removing rust from finished surfaces.

2. Use aluminum-oxide abrasive cloth for removing rust from unfinished surfaces where slight removal of metal will not affect the functioning of the part.

3. Use type II, wipe-off type, concentrated, metal conditioner, phosphoric acid for removal of rust from unfinished surfaces where pits are too deep to be removed with aluminum-oxide abrasive cloth.

(b) *Painted metal surfaces.*

1. Remove paint from rusted area using flint paper (sandpaper) grade 0 to grade 3.
2. Remove rust as prescribed in (a) above, and repaint.

c. LUBRICATION. Lubricate the matériel as prescribed in section XII.

d. APPLICATION OF PRESERVATIVES. Apply preservatives immediately after cleaning and drying as a rust stain will form if matériel is handled between operations.

(1) Remove the trigger solenoid, cap and protector sleeve, and buffer assembly from the gun as described in sections XVIII and XXVIII. These parts will not be treated with preservative lubricating oil.

(2) Loosen or remove the gas cylinder guide and gas plug to permit internal access of the preservative.

(3) Submerge the gun in preservative lubricating oil (medium) at approximately 45°. If prevailing temperature is below 0° F., use preservative lubricating oil (special).

(4) Allow excess oil to drain from the gun and tighten the gas cylinder guide and gas plug.

Note. If the gas cylinder guide and gas plug were removed in (2) above, dip them separately in the preservative lubricating oil before replacing them on the gun.

(5) Replace the buffer assembly, cap, and protector sleeve on the gun.

e. APPLICATION OF PROTECTIVE WRAPPING. (1) Cover the muzzle and breech end of gun with type I, grade C greaseproof wrapping material and overwrap with waterproof barrier material. Secure the wrapping to the gun with nonhygroscopic adhesive tape. Apply tape sealing compound over tape.

(2) Wrap the gun with greaseproof wrapping material at all places where it contacts the shipping box or bracing.

2. Instructions for Limited Storage

a. INSPECTIONS. (1) *Receiving inspections.* (a) When matériel is out of use, it must be turned over to ordnance personnel or placed in a storage status for periods not to exceed 90 days. Storage of matériel for periods in excess of 90 days will normally be handled by *ordnance personnel only.*

(b) Immediately upon receipt of matériel for storage, it must be

inspected and serviced as prescribed in section IV. Make a systematic inspection and replace or repair all missing or broken parts. If repairs cannot be made prior to placing matériel in storage, attach a tag to the matériel specifying the repairs needed and make a written report of these items to the officer-in-charge of the matériel.

(2) *Periodic inspections.* Make a visual inspection periodically to determine general conditions. If corrosion is found on any part, remove the rust spots, clean and treat with the prescribed preservative.

b. REMOVAL FROM LIMITED STORAGE. (1) If the matériel is not shipped or issued upon expiration of the limited storage period, further treat matériel for stand-by storage (matériel out of use for periods in excess of 90 days up to 3 years).

(2) If matériel to be shipped will reach its destination within the scope of the limited storage period, it need not be reprocessed upon removal from storage unless inspection reveals it necessary.

(3) Deprocess matériel when it has been ascertained that it is to be placed into immediate service. Remove all preservative lubricating oil and thoroughly lubricate as prescribed in section XII. Thoroughly inspect matériel and service as prescribed in section IV.

c. PREFERRED STORAGE. The preferred type of storage for this matériel is in closed dry warehouses or sheds. Where it is found necessary to store matériel in the open, cover with tarpaulins. (See SB 9-47.)

3. Instructions for Shipment

a. GENERAL. Instructions for shipment contains information necessary for the construction, packing, and marking of the shipping box for one 20-mm automatic gun M3. For additional basic information on the construction of shipping containers, refer to TM 9-2854.

b. BOXING DATA. Table II contains logistical boxing data for the 20-mm automatic gun M3.

Table II. Logistical data

	Dimensions (inches)		Volume and weight
	Inside	Outside	
Length.....	78½	80	
Width.....	6¼	7¾	
Depth (inside) or height (outside).....	7½	9¼	
Tare weight (lb).....			40
Gross weight (lb).....			140
Cubic displacement (cu ft).....			3.3
Ship tons (40 cu ft).....			.083

c. **BILL OF MATERIAL.** The bill of material required to construct one complete nailed wood shipping box (fig. 220) is listed in table III.

Table III. Bill of material for shipping box

Indicating No.	Quantity required	Part name	Actual size (inches)		
			Length	Width	Thickness
1	2	Ends.....	7½	6¼	¾
2	1	End cleat.....	7½	2½	1½
3	1	End cleat.....	7½	2	1½
4	2	End cleats.....	7½	1¾	1
5	2	Sides.....	80	7½	¾
6	8	Side cleats.....	7½	1	¾
7	2	Top and bottom.....	80	7¾	¾
8	1	Support block.....	6¼	4¼	¾
9	1	Support block.....	6¼	4¼	¾

d. **NAILING SCHEDULE.** This nailing schedule (table IV) is for group I woods. If woods of groups II, III, or IV are used, adjust schedule as prescribed in TM 9-2854.

Table IV. Nailing schedule

Fasten		Nail size and type	Maximum spacing (inches)	Notes
Part	To part			
Cleats (2), (3), and (4).	Ends (1).....	Sixteenpenny box.....	3	Stagger and clinch.
Cleats (6).....	Sides (5).....	Sixpenny box.....	2	Stagger and clinch.
Sides (5).....	Ends (1) and cleats (2), (3), and (4).	Tenpenny box.....	1½	Stagger in four rows.
Bottom (7).....	Ends (1).....	Eightpenny cement-coated.....		Three nails per end.
Bottom (7).....	Sides (5).....	Eightpenny cement-coated.....	2½	
Top (7).....	Ends (1).....	Eightpenny cement-coated.....		Three nails per end.
Top (7).....	Sides (5).....	Eightpenny cement-coated.....	2½	

e. **PACKING.** (1) Place the packaged gun on support blocks (8) and (9) with the muzzle end between end cleats (4), and the receiver end between end cleats (2) and (3).

(2) Place top of container in position and nail. **Caution:** Make sure the gun is thoroughly protected with grease proof wrapping material at all places where it contacts the shipping box and supports, as the top of the box will contact the gun at various places and act as a hold-down support.

f. **MARKING.** Marking for shipment will be in accordance with TM 38-414.

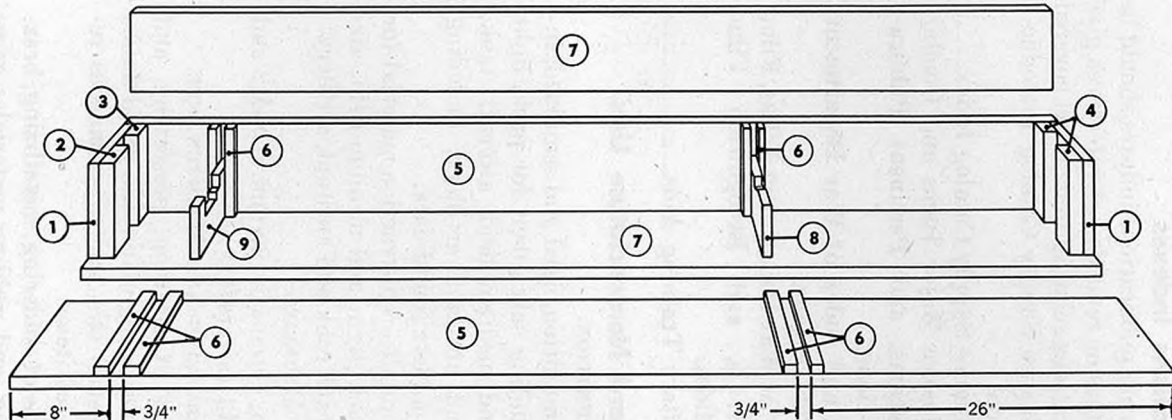
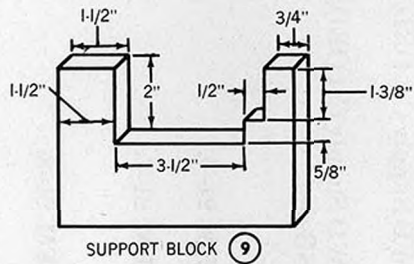
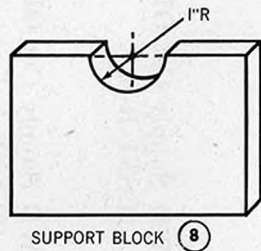

NOTE - NUMBERS IN CIRCLES CORRESPOND TO THE INDICATING NUMBERS LISTED IN THE BILL OF MATERIAL.

Figure 220. Shipping container for one 20-mm automatic gun M3.

RA PD 52493

APPENDIX II REFERENCES

1. Publications Indexes

The following publications indexes should be consulted frequently for latest changes or revisions of references given in this section and for new publications relating to matériel covered in this manual:

- | | |
|---|----------------------|
| Ordnance Supply Catalog Introduction. | WD Supply Cat ORD 1. |
| Ordnance Supply Catalog Index..... | WD Supply Cat ORD 2. |
| Ordnance Major Items and Combinations, and Pertinent Publications. | SB 9-1. |
| List and Index of War Department Publications. | FM 21-6. |
| List of War Department Films, Film Strips, and Recognition Film Slides. | FM 21-7. |
| Military Training Aids..... | FM 21-8. |

2. Standard Nomenclature Lists

a. AMMUNITION.

Ammunition, fixed and semifixed, including subcaliber, for pack, light and medium field, aircraft, tank, and antitank artillery, including complete round data.	WD Supply Cat ORD 11 SNL R-1.
---	----------------------------------

Ammunition instruction material for pack, light and medium field, aircraft, tank and antitank artillery.	WD Supply Cat ORD 11 SNL R-6.
--	----------------------------------

b. GUN MATÉRIEL.

Gun, automatic, 20-mm. AN-M2 and M3 (aircraft).	WD Supply Cat ORD (*) SNL A-47.
---	-------------------------------------

c. PRESERVATION AND MAINTENANCE.

Items of cleaning, preserving, and lubricating materials; recoil fluids, special oils, and miscellaneous related items.	WD Supply Cat ORD 3 SNL K-1.
---	---------------------------------

Items of soldering, metallizing, brazing, and welding materials; gases and related items.	WD Supply Cat ORD 3 SNL K-2.
---	---------------------------------

(*) See WD Supply Catalog ORD 2 Index for published pamphlets of the Ordnance Supply Catalog.

3. Other Publications

a. AMMUNITION.

- Ammunition, General..... TM 9-1900.
Ammunition Inspection Guide..... TM 9-1904.
Artillery Ammunition..... TM 9-1901.

b. CARE AND SERVICE.

- Cleaning, Preserving, Sealing, Lubricating and Related Materials Issued for Ordnance Matériel. TM 9-850.

c. MAINTENANCE AND REPAIR.

- Basic Maintenance Manual..... TM 38-650.
Decontamination..... TM 3-220.
Defense Against Chemical Attack.... FM 21-40.

4. Army Regulations

- Qualifications in Arms and Ammunition Training Allowances. AR 775-10.
Range Regulations for Firing Ammunition for Training and Target Practice. AR 750-10.

5. Storage and Shipment

- Army Marking Directive..... TM 38-414.
Instruction Guide—Ordnance Packaging and Shipping (Posts, Camps, and Stations). TM 9-2854.
Protection of Ordnance Matériel in Open Storage. SB 9-47.

INDEX

	<i>Page</i>
Accidents, field report of	1
Ammunition:	
Authorized rounds:	
Nomenclature	227
Table I	228
Care, handling, and preservation	226
Classification	221
Description—	
Ammunition	221
Rounds	227
Identification	222
Marking for—	
Identification	225
Shipment	229
Packing	229
Painting for identification	225
Preparation for firing	227
Authorized rounds (ammunition)	227
Auxiliary equipment	221
Belts:	
Hand loading	8, 10
Machine loading	42, 45
Bill of material (table III)	234
Bore, maintenance	52, 53
Boxing data (table II)	233
Breechblock:	
Assembly	92
Description:	
Locking action	66
Unlocking action	59
Disassembly	92
Installation	89
Maintenance	96
Maintenance schedule	52
Removal	89
Breechblock group	88
Buffer, rear. (<i>See</i> Rear buffer.)	
Care of ammunition	226
Cartridge case:	
Extraction and ejection	59
Failure to extract and eject	69
Chambering	65

Chargers:

	<i>Page</i>
Adjustment for right- or left-hand charging:	
M4.....	180
M5.....	194
M6.....	202
M7.....	189
Assembly:	
M4.....	183
M5.....	195
M6.....	205
M7.....	189
Data:	
Free length (springs).....	51
General.....	4
Disassembly:	
M4.....	183
M5.....	195
M6.....	205
M7.....	189
Dismounting:	
M4.....	182
M5.....	195
M6.....	204
M7.....	189
Functioning:	
M4.....	178
M5.....	192
M6.....	202
M7.....	187
Installation and removal.....	180
Maintenance:	
M4.....	186
M5.....	201
M6.....	209
M7.....	190
Maintenance schedules.....	52, 53
Mounting:	
M4.....	181
M5.....	195
M6.....	202
M7.....	189
Operation:	
Description.....	7
Instructions for.....	22
Charging gun.....	23
Cleaning:	
Before lubrication.....	48
Before storage or shipment.....	231
Materials for.....	28
Cocking action.....	64
Controls.....	7
Cradle group:	
Description.....	70
Installation.....	72

Cradle Group—Continued.		Page
Maintenance.....		72
Removal.....		72
Cyclic functioning.....		58
Data:		
Free length (springs).....		51
General.....		4
Thread sizes.....		56
Demolition.....		26
Description of gun.....		1
Differences in models.....		3
Driving spring:		
Description:		
Action.....		63
Guide.....		81
Installation.....		82
Maintenance.....		84
Removal of guide.....		81
Dynamic torque test.....		158
Ejection of cartridge case.....		61
Electric heater M1		
Data.....		
Description, removal, and installation.....		217
Maintenance.....		220
Electric motor:		
Assembly.....		176
Disassembly and cleaning.....		173
Inspection and repair.....		175
Testing.....		178
Electric triggers:		
Assembly:		
AN-M1A1.....		209
AN-M4.....		214
Data:		
Free length (springs).....		51
General.....		4
Description:		
AN-M1A1.....		209
AN-M4.....		214
Disassembly:		
AN-M1A1.....		212
AN-M4.....		216
Installation:		
AN-M1A1.....		210
AN-M4.....		215
Maintenance:		
AN-M1A1.....		213
AN-M4.....		217
Maintenance schedules.....		52, 53
Removal:		
AN-M1A1.....		210
AN-M4.....		215

Equipment:	Page
Auxiliary	221
For maintenance	28
Service upon receipt of—	
New	6
Used	7
Use and maintenance of	42
Extraction of cartridge case	59
Failure to—	
Eject	69
Extract	69
Feed	68
Fire	68
Feed mechanisms:	
Assembly:	
AN-M2	120
M3 (left-hand)	159
M3 (right-hand)	150
Converting:	
left-hand to right-hand	168
right-hand to left-hand	167
Data:	
Free length (springs)	51
General	4
Description:	
AN-M2	102
M3	129
Disassembly:	
AN-M2	112
M3 (left-hand)	159
M3 (right-hand)	134
Failure to extract and eject	69
Functioning:	
AN-M2	104
M3	29
Hand loading of belts:	
AN-M2	8
M3	11
Inspection	54
Installation:	
AN-M2	13
M3	18
Loading gun:	
AN-M2	13, 15
M3	18
Machine loading of belts	42, 45
Maintenance:	
AN-M2	125, 127
M3	165, 168
Maintenance schedules	52, 53
Operation:	
Description:	
AN-M2	106

Feed Mechanisms—Continued.	
Operation—Continued.	
Description—Continued.	Page
M3.....	18
Instructions for.....	22
Feed slide:	
Adjustment.....	18
Installation.....	18
Maintenance.....	52
Feeding.....	65
Fire interrupter switch.....	8
Firing action.....	67
Firing switch.....	8
Firing tables.....	221
Firing gun.....	23, 57
Flash hider M4.....	73
Function firing.....	57
Function testing.....	57
Functioning, cyclic.....	58
Fuzes.....	227
Gas cylinder sleeve group:	
Disassembly and assembly.....	97
Functioning.....	57
Maintenance.....	54, 98, 99
Gun tube:	
Description.....	73
Maintenance.....	76
Handling of ammunition.....	226
Heater, electric, M1. (See Electric heater M1.)	
Identification information.....	3
Identification of ammunition.....	222
Inspection for—	
General ordnance maintenance.....	54
Limited storage.....	232
Preventive maintenance.....	54
Linking machines:	
Adjustment:	
M4.....	42
M13.....	44
Loading:	
M4.....	43
M13.....	45
Loading of belts:	
Hand.....	8, 10
Machine.....	42, 45
Loading switch.....	8
Loading gun:	
Feed mechanism AN-M2.....	13, 15
Feed mechanism M3.....	18
Lot number (ammunition).....	225

Lubrication:	
Feed mechanism:	<i>Page</i>
AN-M2.....	125
M3.....	165
For storage and shipment.....	232
Instructions.....	48, 49
Intervals and methods.....	49
Lubrication order.....	48
Materials.....	28
Machines, linking. (See Linking machines.)	
Magazine slide:	
Adjustment.....	13
Assembly.....	87
Description.....	85
Disassembly.....	85
Maintenance.....	52, 87
Removal.....	19
Maintenance:	
Common procedures.....	51, 56
Inspection for.....	50, 54
Instructions.....	28
Ordnance service.....	54
Preventive service.....	51
Schedules.....	52, 53
Thread data.....	56
Malfunctions and corrections.....	67
Marking for—	
Identification (ammunition).....	222
Shipment.....	233
Mechanisms, feed. (See Feed mechanisms.)	
Misfire.....	67
Motor. (See Electric motor.)	
Nailing schedule (table IV).....	234
Operating instructions.....	6
Operation under unusual conditions.....	25
Packing for shipment.....	234
Painting of ammunition.....	225
Parts:	
Spare.....	28
Thread data.....	56
Preservation of ammunition.....	226
Preserving materials.....	28
Preventive maintenance. (See Maintenance.)	
Rear buffer:	
Description.....	63, 81
Installation.....	82
Maintenance.....	84
Removal.....	81

	<i>Page</i>
Receiver:	
Description.....	76
Maintenance.....	78
Recoil action.....	59
Recoil group:	
Disassembly and assembly.....	99
Maintenance.....	99
Records.....	1
Run-away gun.....	70
Sear mechanism:	
Assembly.....	96
Disassembly.....	94
Maintenance.....	96
Removal and installation.....	91
Serial numbers.....	3
Shipment. (See Storage and shipment.)	
Slides. (See Magazine slide; Feed slide.)	
Slow firing gun.....	70
Spare parts.....	28
Static torque test.....	154
Stoppage in firing.....	24
Storage and shipment:	
Instructions for—	
Limited storage.....	232
Shipment.....	233
Preparation of matériel.....	231
Switches.....	8
Temperatures, operation under high and low.....	25
Testing:	
For ordnance maintenance.....	54
Function testing.....	57
Ground and air testing.....	67
Tests:	
Dynamic torque test.....	158
Static torque test.....	154
Tools:	
Authorized tools.....	29
Improvised tools.....	31
Triggers, electric. (See Electric triggers.)	
Tube, gun. (See Gun tube.)	
Tube and receiver group.....	73
Unloading gun.....	24
Unsatisfactory report.....	1
Unusual conditions, operation under.....	25

