

FOR REFERENCE ONLY

# TM 9-1300-205

DEPARTMENT OF THE ARMY TECHNICAL MANUAL

---

310 2e

Sub Ref Set Files

AM

TOP MORTARS

YYZ-058



HEADQUARTERS, DEPARTMENT OF THE ARMY

SEPTEMBER 1960

7/16/63

TECHNICAL MANUAL  
AMMUNITION FOR MORTARS

TM 9-1300-205 }  
CHANGES No. 3 }

HEADQUARTERS,  
DEPARTMENT OF THE ARMY  
WASHINGTON 25, D.C., 12 June 1963

TM 9-1300-205, 21 September 1960, is changed as follows:

Page 17, paragraph 18e(1)(b). Add the following caution:

**Caution:** When firing the 81-mm HE cartridge M43A1 using two increments of increment propellant charge M1A1, the increments must be placed directly opposite each other (symmetrical) in order to prevent loss of fins and short rounds.

Page 20, paragraph 19a. Add the following

**Caution:** When firing the 81-mm HE cartridge M43A1 using two increments of increment propellant charge M1A1, the increments must be placed directly opposite each other

(symmetrical) in order to prevent loss of fins and short rounds.

Page 23.

21.1. (As added by C1, 17 Oct 61) Cartridge, 81 Millimeter: HE M362A1, w/Fuze, PD, M524 (or PD M526 Series or PD, M519 Proximity, M517 (T178E3), or w/o Fuze (Plugged)

Cartridge M362A1 is similar to Cartridge M362 (par. 21) except for the material of which the body is made. The body of Cartridge M362A1 is made of pearlitic malleable iron, that produces near optimum fragmentation when the explosive charge detonates.

Page 28.

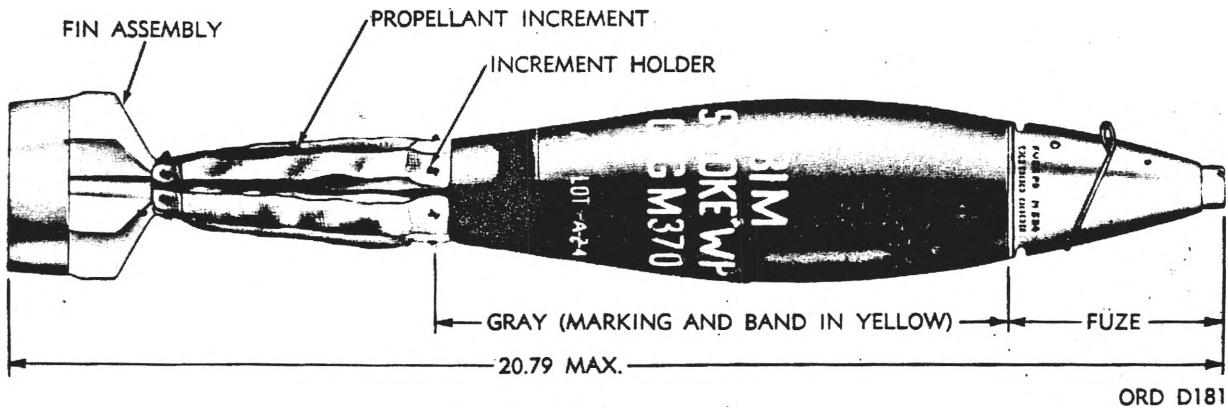

Figure 11. (Superseded) Cartridge, 81 millimeter: smoke, WP, M370 (T30E9), w/fuze, PD, M524.

\* These changes supersede C2, 18 September 1962.

## 28. General

\* \* \* \* \*  
e. *Propelling Charge* (As changed by C 2, 18 Sep 62) Dependent upon model \* \* \* the container extension. When the number of increments of the propelling charge M36 is reduced to *less than* 25½ increments, the striker nut, ignition cartridge, and cartridge container ex-

tension are removed. The ignition cartridge \* \* \* chemical cartridge M2A1. When the number of increments of propelling charge M36 is reduced to 25½ increments, use of the cartridge container extension is optional. The cartridge container extension must be used when firing with more than 25½ increments. Any or all \* \* \* cartridge container extensions.

**FUZE INTERCHANGEABILITY CHART—MORTAR AMMUNITION**

<input type="checkbox"/> AUTHORIZED FUZES <input type="checkbox"/> E FUZES FOR EMERGENCY USE WITHOUT ADDITIONS OR MODIFICATIONS <input type="checkbox"/> S REQUIRES REMOVAL OF SUPPLEMENTARY CHARGE		MECHANICAL TIME AND SUPERQUICK		POINT DETONATING																	PROXIMITY	TIME	TIME AND SUPER-QUICK	
CANNON	CARTRIDGE	M500 SERIES	M501 SERIES	M520	M3 IMPROVED	M8	M9	M51A5	M52 SERIES MODIFIED	M52 SERIES	M53 SERIES	M52 SERIES	M519	M521	M524	M525 SERIES	M526 SERIES	M527 SERIES	M535	M513 SERIES	M517 SERIES	M55 SERIES	M54	M77
60-MM MORTAR M2 AND M19	HE M49A2									E	E	E												E
	ILLUMINATING M83 SERIES																							
	SMOKE WP M302											E												
81-MM MORTAR M1 AND M29	HE OR TP M43 SERIES									E	E	E												E
	HE M56 SERIES									E		E												
	HE OR TP M362 SERIES												E											
	ILLUMINATING M301 SERIES																							
	SMOKE FS OR WP M57 SERIES									E	E	E												
	SMOKE WP M370												E											
4.2 INCH MORTAR M30	GAS CG, H, HD, HT, M2 SERIES																							
	HE M3								E															
	HE M3A1 W/SUPPL CHG																						S	
	HE M329 W/SUPPL CHG																						S	
	ILLUMINATING M335																							
	SMOKE PWP OR WP M2 SERIES																							
	SMOKE M328																							

Chart 1 (Superseded) Fuze Interchangeability Chart—Mortar Ammunition.

40. Fuze, Point Detonating: M8

b. Safety Features. The fuze M8 has four safety features:

(3) The *retainer* is \* \* \* two steel balls.

Note. (Added). Some retainers do not have the slots or holes through which the steel balls can be seen.

d. (Superseded) Preparation for Firing.

- (1) Examine fuze to see that the shear wire is in place and bent over at both ends.
- (2) Ends of safety pin may be straightened with pliers to facilitate rapid removal by mortar squad when ready to fire.
- (3) Adjust propelling charge, if required.
- (4) Pull on safety pin ring and remove safety pin from fuze body just before ready to fire.

Caution No. 1: If striker assembly moves up so that there is a gap of approximately one-quarter (1/4) of an inch between it and the fuze body, the steel safety (locking) balls are missing and the fuze is in a partially armed position. If this is the case, reinsert safety pin into fuze body. The round must not be fired but will be placed in a segregated location for disposition by authorized personnel in accordance with TM 9-1903. If the striker assembly does not move up, the steel safety (locking) balls are present, the fuze is in an unarmed position and the round may be fired.

Caution No. 2: If the round is not

fired immediately, the safety pin must be reinserted in the fuze body.

Page 53.

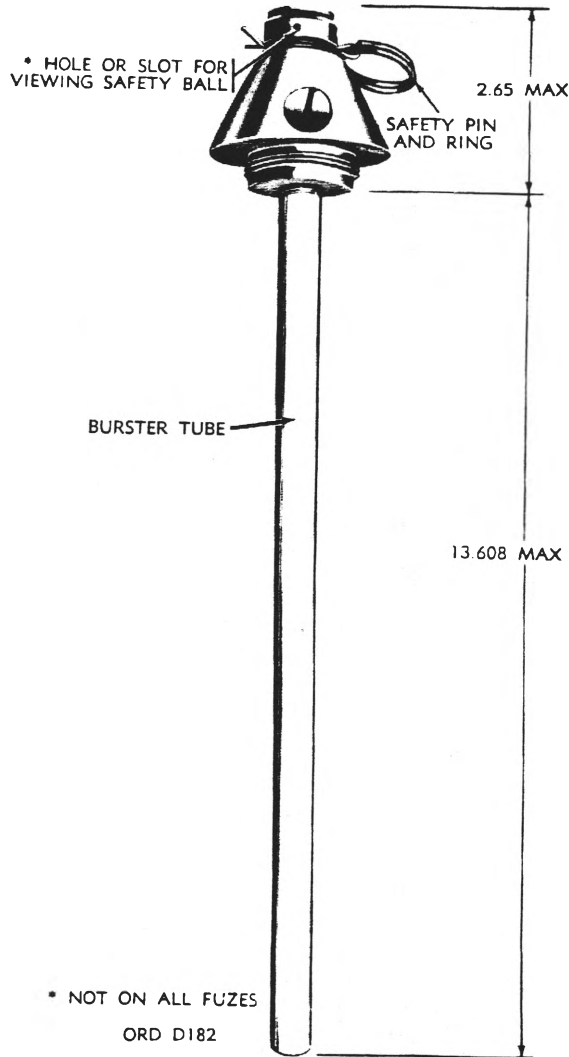

Figure 27. (Superseded) Fuze, Point Detonating: M8.

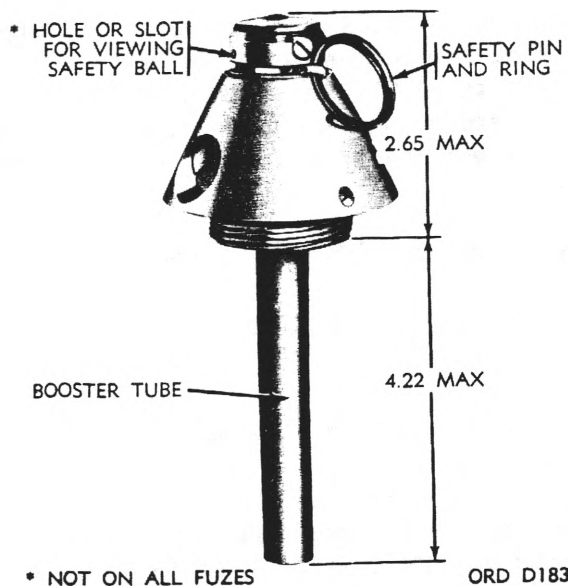

Figure 28. (Superseded) Fuze, Point Detonating: M9.

**49. Fuze, Point Detonating: M525A1 and M525**

a. *Description.* These fuzes (figs. 36 and 37) \* \* \* pin, and booster. The fuzes M525A1 and M525 are used with the 60-mm high-explosive cartridge M49A2, the 81-mm high-explosive cartridges M43 series and M56 series, 81-mm target practice cartridge M43 series, and the 81-mm WP cartridges of the M57 series.

**56. Proximity Fuzes**

b. *Identification.*

(1) *Alphabetical classification numbers and letters.* The alphabetical classifi-

cation \* \* \* different classification letters. Whenever possible, two or more of these classifications will be issued to each using unit, so that they may be fired concurrently by each battery. Such mixing will \* \* \* of the fuzes.

\* \* \* \* \*

d. (Superseded) *Characteristics.* Arming of the impact element is delayed by a series of safety devices for at least 3 seconds after firing (regardless of time setting) for the fuze M513A1 (T226E2); until at least 3 seconds prior to the time setting for the fuze M513B1 (T226B1) or M513 (T226); for at least 1.5 seconds for the fuze M517 (T178E3). The proximity element is delayed for at least 3 seconds prior to the time setting of fuze M513-A1 (T226E2), M513B1 (T226B1) or M513 (T226); for at least 4 seconds under normal conditions or 3.2 seconds under abnormal conditions for fuze M517 (T178E3) (no setting required). The proximity fuzes are completely boresafe. Height of burst of proximity fuzes above terrain, varies with large changes in angle of fall, becoming lower as the angle of fall becomes steeper. These fuzes are designed to give optimum burst above average soil; however, the average height of burst is slightly higher over moist soil than over dry soil and 50 percent higher over marshy or very wet terrain than over dry land. The height of burst over a body of water may be approximately two to four times the height of burst over land. Light tree foliage and vegetation do not affect the height of burst materially, but dense tree foliage and thick vegetation will increase the height of burst above ground. This effect is decreased at a steep angle of fall, at which most projectiles will burst below treetop level. The dispersion in height of burst decreases as the time of flight is increased.

e. (Superseded) *Use.* The proximity fuzes may be used as indicated in table IV.

Table IV. (Superseded) Authorized Use of Proximity Fuzes

Fuze	Weapon	Cartridge	Propelling charge	Minimum usable range (yd)
M513A1 (T226E2) .....	4.2-inch mortar M30.....	M3A1	More than 10 increments	1,800
M513B1 (T226B1) .....		M329		
M513 (T226)	81-mm mortars M1 and M29..	M362 series	Any charges	No minimum usable range.
M517 (T178E3) .....				

**57. Fuze, Proximity: M513A1 (T226E2)**

*a. General.*

\* \* \* \* \*

(5) (Superseded) The fuzes M513B1 (T226B1) and M513 (T226) differ primarily from the fuze M513A1 (T226E2) in that when the fuze is set on 5 to 100 seconds, *the proximity element and the impact element* become armed approximately 3 seconds prior to the set time. The fuze M513 (T226) is 1/2 pound heavier than the fuzes M513A1 (T226E2) and M513B1 (T226B1). The fuzes M513 (T226) and M513B1 (T226B1) have an "S" (shipping line) marking in the slot (notch) instead of "PD" as in the case of the fuze M513A1.

\* \* \* \* \*

*c. Preparation for Firing.* Time settings are made in the same manner as for the mechanical time fuze, namely, while looking axially at the nose of the fuze, rotate the fuze setter M14 or M27 in a clockwise direction.

By Order of the Secretary of the Army:

Official:

J. C. LAMBERT,  
Major General, United States Army,  
The Adjutant General.

Distribution:

*Active Army:*

- |                 |                  |                          |
|-----------------|------------------|--------------------------|
| DCSLOG (1)      | OS Maj Comd (2)  | OASMS (10)               |
| CNGB (1)        | OS Base Comd (2) | Ord Arsenals (5) except  |
| CSigO (1)       | LOGCOMD (1)      | Raritan Arsenal (10)     |
| CofEngrs (1)    | MDW (1)          | Picatinny Arsenal (8)    |
| TSG (1)         | Armies (3)       | Units org under fol TOE: |
| CofT (1)        | Corps (2)        | (2 copies each)          |
| USAMC (5)       | USA Corps (2)    | 9-26                     |
| USAOCDA (1)     | Div (2)          | 9-76                     |
| USACDC (2)      | Instls (2)       | 9-86                     |
| USCONARC (3)    | USAMUCOM (35)    | 9-367                    |
| ARADCOM (2)     | Svc Colleges (2) | 9-500 (AA, AB, AC)       |
| ARADCOM Rgn (2) | Br Svc Sch (2)   | (BB, BC) (IA, KA)        |

NG: State AG (3); Units—Same as Active Army except allowance is one copy for each unit.

USAR: None.

For explanation of abbreviations used, see AR 320-50.

Page 82, paragraph 62. Add the following caution:

**Caution:** When firing the 81-mm HE cartridge M43A1 using two increments of increment propellant charge M1A1, the increments must be placed directly opposite each other (symmetrical) in order to prevent loss of fins and short rounds.

**63. Propelling Charge for 4.2-Inch Mortar Cannon**

Two types of propelling charge are used with the 4.2-inch mortar cannon.

\* \* \* \* \*

*b. The propelling charge* \* \* \* removed and discarded. See figure 50.

**Caution:** (As superseded by C 2, 18 Sep 62) When the high-explosive cartridge M329, the illuminating cartridge M335, and the smoke cartridge M328 are fired in the 4.2-inch mortar M30 with more than 25 1/2 increments, the cartridge container extension must be used; it is not used when firing with less than 25 1/2 increments, and must be removed. The cartridges may be fired with or without the cartridge container extension when firing with 25 1/2 increments.

EARLE G. WHEELER,  
General, United States Army,  
Chief of Staff.

**AMMUNITION FOR MORTARS**

	Paragraph	Page
<b>CHAPTER 1. GENERAL.</b>		
Section I. Introduction -----	1- 3	3
II. General discussion -----	4-12	3-6
<b>CHAPTER 2. CARTRIDGES</b>		
Section I. Cartridges for 60-mm mortar cannons M2 and M19 -----	13-17	7-15
II. Cartridges for 81-mm mortar cannons M1 and M29 -----	18-27	15-28
III. Cartridges for 4.2-inch mortar cannon M30 -----	28-35	28-41
<b>CHAPTER 3. FUSES, PROPELLING CHARGES, IGNITION CARTRIDGES, PRIMERS, BOOSTERS, BURSTERS, SUPPLEMENTARY CHARGES, AND OTHER COMPONENTS</b>		
Section I. Fuses -----	36-59	42-80
II. Propelling charges -----	60-63	80-84
III. Ignition cartridges and primers -----	64-74	84-88
IV. Boosters, bursters, supplementary charges, adapters, and closing plugs ----	75-85	88-92
<b>CHAPTER 4. MORTAR AMMUNITION FOR SUBCALIBER EQUIPMENT -----</b>	<b>86-88</b>	<b>93</b>
5. DESTRUCTION OF AMMUNITION TO PREVENT ENEMY USE ----	89-91	94, 95
<b>APPENDIX REFERENCES -----</b>		<b>96-98</b>
<b>INDEX -----</b>		<b>99-101</b>

\* This manual, together with TM 9-1901-1, 18 December 1957; TM 9-1300-204, 25 May 1959; and TM 9-1300-203, 15 August 1960, supersedes TM 9-1901, 11 September 1950, in its entirety, and TB ORD 417, 17 July 1953. Applicable information of TB ORD 630, 19 March 1957, and C1, 11 October 1957, has been incorporated in this manual; however, this bulletin will remain in force until incorporated in all affected publications or specifically rescinded.

# CHAPTER 1

## GENERAL

---

### Section I. INTRODUCTION

#### I. Purpose

This manual is intended for instruction and the dissemination of such general and technical information concerning mortar ammunition and components thereof, as may be necessary for care, handling, and use. This is a companion volume to TM 9-1900, which covers general information on explosives and chemical agents and basic types of ammunition, and to TM 9-1903, which covers information on care, handling, preservation, and destruction of limited quantities of unserviceable, unsalvageable, or hazardous ammunition.

#### 2. Scope

a. Ammunition for use in 60-mm, 81-mm, and 4.2-inch mortars is described herein. This manual covers the general characteristics, specific data, means of identification, special precautions in handling and use, and general information on packing and shipping this ammunition.

b. Information concerning the destruction of ammunition in case of imminent capture by the enemy is also included.

c. Any errors or omissions will be forwarded on DA Form 2028 direct to the Commanding Officer, Raritan Arsenal, Metuchen, New Jersey, ATTN: ORDJR-OPRA.

d. This manual differs from pertinent portions of TM 9-1901, 11 September 1950, which it partly supersedes, as follows:

- (1) Adds information on later model cartridge for 81-mm mortar cannons M1 and M29, and for 4.2-inch mor-

tar cannon M30.

- (2) Adds information on later model fuzes, primers, and propelling charges for 60-mm, 81-mm, and 4.2-inch mortar cannons.
- (3) Adds information on M525, M526, and M527 series fuzes, modification of earlier model fuzes.
- (4) Deletes information with reference to 4.2-inch mortar cannon M2.

#### 3. Forms and Reports

a. *Authorized Forms.* The forms generally applicable are listed in the appendix. For instructions on use of these forms, refer to FM 9-1. For a listing of all forms, refer to DA Pam 310-2.

b. *Field Report of Accidents.*

- (1) *Injury to personnel or damage to materiel.* The reports necessary to comply with the requirements of the Army safety program are prescribed in detail in AR 385-40. These reports are required whenever accidents involving injury to personnel or damage to materiel occur.
- (2) *Ammunition.* Whenever an accident or malfunction involving ammunition occurs, firing of ammunition from the lot in which malfunction occurred will be immediately discontinued. In addition to any applicable reports required in (1) above, details of the accident or malfunction should be immediately reported as prescribed in AR 700-1300-8 and AR 385-63.

### Section II. GENERAL DISCUSSION

#### 4. Definitions

a. Ammunition comprises that class of supplies usually containing explosives and chemicals and intended for use in combat, simulated combat, or training.

b. A cartridge (complete round of artillery ammunition) comprises all of the components necessary to fire the weapon once. For mortar ammunition this includes: a *loaded projectile*; a *propelling charge* to develop the required gas pressure necessary to propel the projectile to its target; a *primer* to initiate the burning of the ignition charge which in turn ignites the propelling charge; and a *fuze* to cause the projectile to function at the time and under the conditions desired.

c. Mortar cartridges are known as *semifixed* ammunition. *Semifixed* ammunition is characterized by an accessible propelling charge which may be adjusted for charge firing. A cartridge is loaded into the weapon as a unit. The propelling charge is divided into increments, each containing propellant assembled in bags or sheets. To adjust the charge, the undesired increments are removed from the fins (60-mm and 81-mm), the cartridge housing (81-mm), or the cartridge container (4.2-inch).

#### 5. Classification

a. Mortar ammunition is classified according to use as service, practice, or training.

- (1) *Service ammunition*. Service ammunition is fired for effect in combat. Dependent upon type of projectile, it may be chemical (gas or smoke), high-explosive (HE), or illuminating.
- (2) *Practice ammunition*. Target-practice (TP) ammunition is fired in simulated combat and is provided for training in marksmanship. The projectile has an inert filler and a small quantity of low explosives to serve as a spotting charge.
- (3) *Training ammunition*. Training ammunition consists of a completely inert projectile for training mortar crews, forward observers, and fire direction personnel of mortar units. It is propelled by a shotgun-type ignition cartridge.

b. Subcaliber equipment M31 (pa. 87), for

use in the 4.2-inch mortar M30, is intended for practice firing. Any type 60-mm mortar ammunition may be fired from the subcaliber equipment as no ammunition is manufactured specifically as subcaliber ammunition for mortars.

#### 6. Standard Nomenclature

Standard nomenclature is for the purpose of identifying each item of ammunition specifically by name. It consists of the type, size, and model of each item. The use of standard nomenclature for all purposes of record is mandatory. This nomenclature (description), together with Federal stock numbers and other data, is published in Department of the Army supply manuals for use in connection with shipping, storing, requisitioning, and issue. Mortar ammunition and components are grouped in the manuals as indicated in a through c below.

a. SM 9-5-1310 contains lists of ammunition for weapons over 30-mm to 75-mm.

b. SM 9-5-1315 contains lists of ammunition for weapons of 75-mm through 125-mm.

c. SM 9-5-1390 contains a list of fuzes, primers, and explosive components, boosters, supplementary charges, etc., for the ammunition classified in SM 9-5-1310 and SM 9-5-1315.

#### 7. Identification

Ammunition is completely identified by painting and marking (which includes the ammunition lot number) on original packing containers. Once removed from its packing, ammunition may be identified by painting and marking on the ammunition items. For further information concerning identification, model designation, ammunition lot number, painting and marking, and weight-zones, refer to TM 9-1900.

#### 8. Care, Handling, and Preservation

Ammunition is packed to withstand conditions ordinarily encountered in the field, moisture-resistant containers and suitable packing boxes or crates being used to provide the desired protection for shipment and storage. Care must be observed to keep packing boxes from becoming broken or damaged. *Explosive ammunition, or components containing explo-*

sives must be handled with appropriate care at all times. Explosive elements, such as in primers and fuzes, are sensitive to undue shock and high temperature. For further information on care, handling, and preservation of explosives and ammunition, refer to TM 9-1903.

## 9. Storage Precautions

Explosives and ammunition should be stored in buildings designed, designated, and isolated for the specific purpose. Ammunition and explosives will not be stored in buildings which are used for other purposes. When specifically constructed magazines are not available, the buildings used must afford good protection against moisture and excessive changes in temperature and have means for adequate ventilation. For further information on storage of explosives and ammunition, refer to TM 9-1903.

## 10. Projectiles

Dependent upon type of projectile, ammunition may be classified as indicated in paragraph 5. More complete descriptions of the various types of projectiles are given below and in TM 9-1900.

*a. High-explosive (HE) Projectile.* High-explosive projectiles, which are made of various metals, either forged or cast, have comparatively thin walls and a large bursting charge of trinitrotoluene (TNT) or other high explosive. They are used against personnel and materiel targets, producing blast effect and fragmentation at the target. They may be fitted with a time, impact, or proximity-type fuze according to the action desired and the depth of the fuze cavity ("shallow," "normal," or "deep") in the projectile. Projectiles for the 4.2-inch mortar which can be assembled with proximity fuzes are of the deep-cavity type but are adapted for use with standard time or impact fuzes by means of a supplementary charge.

*b. Chemical or Smoke Projectile.* Chemical or smoke projectiles designed for use in the 60-mm, 81-mm, and 4.2-inch mortar are of the burster type. These projectiles are similar to the high-explosive projectile except for the type of filler, which consists of a chemical such as gas or smoke. An explosive charge, termed

a burster charge, located axially in the projectile, is used to rupture the projectile body and aid in dispersion of the chemical filler.

*c. Illuminating Projectile.* Illuminating projectiles contain a parachute and an illuminate assembly that are ejected by an expelling charge adjacent to the fuze. The illuminate suspended by the parachute burns, illuminating a desired point or area.

*d. Target-Practice Projectiles.* Target practice projectiles simulate the service projectiles and have the same dimensions, weight, and center of gravity as the service projectiles. The projectile cavity is filled with an inert material, except for a black powder spotting charge at the front of the cavity.

*e. Training Projectiles.* Training projectiles are provided for training in loading and firing the mortar. This projectile differs from the target-practice projectile in that it is completely inert and has no fuse. For the 60-mm and 81-mm mortars, it consists of a teardrop or pear-shaped body, drilled and threaded at the base end to hold a service-type fin assembly. The ignition cartridge and primer are the only elements required to fire this projectile.

*f. Projectiles for Proximity Fuzes.*

(1) *81-mm projectile.* High-explosive projectiles for the 81-mm mortar have two types of fuze cavities. The projectiles of the M43 series and M56 series have "shallow" fuze cavities. The projectile M362, having a "normal" fuze cavity, is adaptable for use with proximity fuzes. For the fuzing procedure, refer to paragraph 18d(3). All mortar projectiles are issued fitted with point fuzes.

(2) *4.2-inch projectile.* High-explosive projectiles for the 4.2-inch mortar have deep cavities with supplementary charges and point fuzes or closing plugs. For procedure for fuzing the deep-cavity projectile with proximity fuzes, refer to paragraph 28d(3).

## 11. Packing and Marking

*a. General* Moisture-resistant or waterproof containers are used for mortar ammunition.

tion. These packing containers are marked to furnish all essential information. Ammunition data cards accompany shipping tickets for ammunition packings. Firing tables are inclosed in the packings of complete rounds of ammunition. Specific packing data for each ammunition item will be found in SM's 9-5-1310, 9-5-1315, and 9-5-1390.

*b. Packing.* The cartridges are individually packed in either fiber or metal containers, some having U-shaped packing stops fitted into the fuze wrench slots. These must be removed before firing. The fiber containers are overpacked in metal or wooden boxes or metal containers. Ignition cartridges and percussion primers are packed in cartons which are overpacked in wooden boxes. Propellant increment charges for the 60-mm and 81-mm mortars are packed in moisture-resistant or waterproof bags. These bags are packed in fiber containers which are overpacked in wooden boxes. Propellant increment charges for the 4.2-inch mortar are packed in metal cans which are overpacked in wooden boxes. Fin assemblies are packed in fiberboard or wooden boxes. Point detonating and mechanical time-and-superquick fuzes are packed in cans or fiber containers, which are overpacked

in wooden boxes. Proximity fuzes are packed in metal cans which are overpacked in metal or wooden boxes. Metal containers are painted olive drab.

*c. Fiber Containers.* Each fiber container for a cartridge is sealed with an adhesive sealing strip that is the same color as the ammunition in the container, in accordance with basic color scheme described in TM 9-1900.

*d. Outer Containers.* Outer containers containing ammunition are closed in a manner that will indicate whether the container has been tampered with. When lead seals are used for this purpose, they are stamped with letters US, except that in the case of ammunition made in Japan they are stamped UJS. In addition, wooden boxes are secured by metal strapping encircling the box.

*e. Marking for Shipment.* Ammunition items are marked as described in TM 9-1900. Packing boxes are marked as described in TM 9-1903.

## 12. Firing Tables

The firing tables applicable to mortar ammunition are packed in each packing box. An index to firing tables is contained in DA Pam 310-3.

## CHAPTER 2

### CARTRIDGES

#### Section I. CARTRIDGES FOR 60-MM MORTAR CANNONS M2 AND M19

#### 13. General

*a. Weapon Description.* The 60-mm mortar M2 and M19 are smoothbore, muzzle-loading, high-angle fire weapons. Mortar M19 has a firing mechanism which permits selective firing by "drop fire" or "lever fire." It consists of a tube with a base cap containing a removable firing pin. Mortar M2 can be used for drop fire only. However, mortar M2 may be converted to the mortar M19 by replacing the original base cap with the combination base cap and firing mechanism. The mount consists of two units, the bipod and the base plate. The barrel or tube is attached to the bipod by a clamp, and is easily dismounted. The barrel or tube is fastened to the base plate by inserting the spherical projection into the base cap socket and then closing the locking lever. The mortar M19 may be used for direct fire missions by eliminating the bipod and substituting a smaller base plate for the conventional base plate. For illustration of mortar cartridge being fired, see figure 1. All the cartridges that are authorized for use in the 60-mm mortar M2 are also authorized for use in the 60-mm mortar M19. Ammunition for these mortars is also authorized for use in 60-mm subcaliber mortar M31. For additional information on ammunition for subcaliber mortars, refer to paragraphs 86 through 88.

*b. Identification.* The characteristic shape, the grooved bourrelet, and the use of the fin assembly to hold a propelling charge as well as to provide stability in flight are identifying features of 60-mm mortar ammunition. Painting and marking for identification is in accordance with the basic color scheme prescribed in TM 9-1900. See also figures 1 through 6.

*c. Type of Projectiles.* Ammunition for these mortars is classified as high-explosive (HE), illuminating smoke (WP), target-practice (TP), and training, according to the type of filler in the projectile.

*d. Fuze.* Two types of point fuzes are used with 60-mm mortar ammunition impact and fixed-time. Descriptions of these types and the rounds with which each type is used are given in (1) and (2) below. For additional information on these fuzes, refer to paragraph 36 through 59 and fuze interchangeability chart (par. 36).

- (1) *Impact.* The PD fuzes M525A1 and M525, single-action superquick type, are used with high-explosive and target-practice cartridges. PD fuzes M527A1 and M527 are used with smoke cartridges. As an interim measure, target-practice cartridges fitted with PD fuzes of the M52 series modified by replacing the tetryl booster with a black powder charge may be used for training only. The PD fuzes of the M525 series are replacing the PD fuzes M52A1, M52A1B1, M52A2, and M52A2B1. The PD fuzes of the M526 series are replacing the PD fuze M519. The PD fuze of the M527 series are replacing the PD fuzes M82, M82A1, and M82A1B1 which are modifications of PD fuzes of the M52 series.

*Note.* Cartridges fitted with M52 series, M82 series, or M519 series fuzes are issued for emergency combat only.

**WARNING: Do not fire cartridges fitted with M52 series, M82 series and M519 fuzes over the heads of friendly troops.**

- (2) *Fixed-time.* The powder-train (fixed) time fuzes M65A1 or M65 are

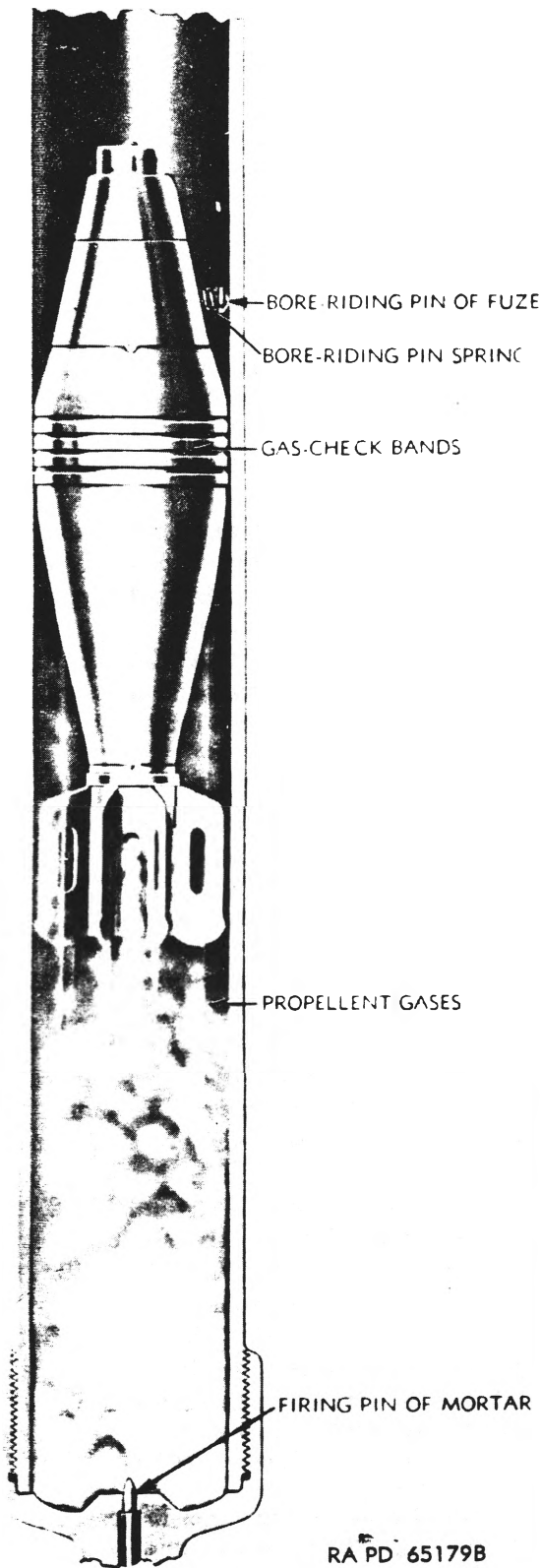

RA PD 65179B

Figure 1. 60-mm cartridge being fired.

used with the illuminating cartridge.

*e. Propelling Charge.* The full propelling charge for 60-mm mortar ammunition, except for training ammunition ( (2) below), consists of the ignition cartridge M5A1 and four propellant increment charges M3A1. Any or all of the propellant increments may be removed for fire adjustment in accordance with appropriate firing tables.

(1) *Propelling charge for high-explosive, smoke, and target-practice cartridges.*

(a) *Ignition cartridge.* The ignition cartridge M5A1 is used for firing charge O. When firing other than charge O, the ignition cartridge also serves to ignite the propellant increment charges.

(b) *Propellant increment charges.* Four propellant increment charges M3A1 are provided for fire adjustment (charge firing). To prepare the ammunition for fire adjustment, it is only necessary to remove the propellant increments not required from the increment holder.

(2) *Propelling charge for training ammunition.* The full propelling charge for the training projectile M69 consists of the ignition cartridge M4 or ignition cartridge M5A1 with percussion primer M32.

*Note.* Refer to paragraph 60 through 63 for additional information on propelling charges; refer to paragraphs 64 through 74 for additional information on ignition cartridges.

*f. Primer.* The percussion primer M32, a threaded screw-in type, is used to ignite the ignition cartridge M5A1 in all 60-mm mortar ammunition. When firing training projectile M69 with ignition cartridge M4, no separate primer is required since this ignition cartridge contains a primer in its base. Refer to paragraphs 64 through 74 for description of this primer.

*g. Fin Assembly.* The fin assembly M2 is used with all 60-mm mortar ammunition except the training projectile M69. The training projectile M69 uses the fin assembly M5 or a modified fin assembly M2. Refer to paragraphs 14 and 17 for additional information on these fins.

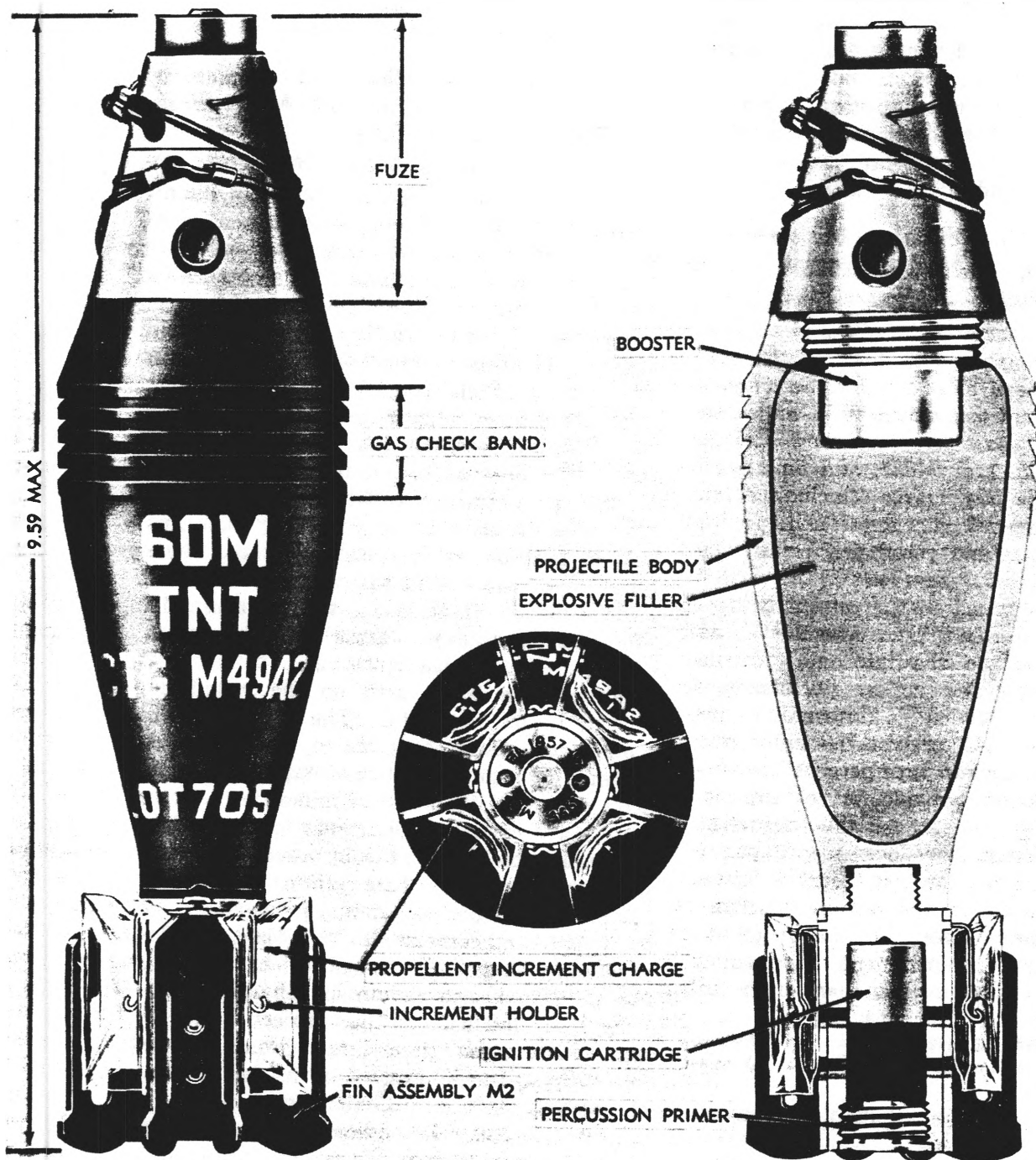

RA PD 80729C

Figure 2. Cartridge, 60 millimeter: HE, M49A2, w/fuze, PD, M525A1.

*h. Packing and Shipping Data.* Dependent upon type of round, 60-mm mortar ammunition, except for training projectiles, is packed one complete round per fiber container and 8, 10, 12, 14, 16, 19, or 25 containers per wooden or metal box. Training projectiles are packed 12, 20, 25, or 36 rounds (without fiber containers) per metal, wooden, or metal-lined wooden box. For additional information on packing of 60-mm mortar ammunition, see paragraph 11 and SM 9-5-1310.

**14. Cartridge, 60 Millimeter: HE M49A2, w/Fuze, PD, M525A1 or M525**

*a. General.* This cartridge (fig. 2) is for use against light materiel targets and against personnel, functioning with both fragmentation and blast effect. The complete round consists of a relatively thin-walled steel projectile body, a TNT bursting charge, PD fuze M525A1 or M525, and fin assembly M2 with propelling charge (including four propellant increment charges M3A1, ignition cartridge M5A1, and percussion primer M32). At the time of manufacture, the fuze is assembled and staked to the internally threaded projectile nose; the fin assembly is assembled and staked to the internally threaded projectile base. The hollow perforated fin assembly shaft, which is internally threaded at its base end, receives the ignition cartridge and the screw-in type percussion primer. The perforations provide for transmission of the cartridge flash to the propellant increment charges. A cellophane-wrapped propellant increment charge is inserted between the blades of each fin and held in position by a spring-clip-type increment holder. Any or all of the propellant increment charges may be removed for fire adjustment by pulling them from under the increment holder clips.

*Note.* Rounds fitted with M52 series fuzes, some of which are on hand, are issued for use in emergency combat only.

*b. Physical Data.*

Weight of complete round with fuze PD M525A1\_ 3.07 lb  
 Length of complete round\_ 9.59 in.

*c. Ballistic Data.*

Charge	Muzzle velocity (fps)	Maximum range (yd)
Charge 0 (ignition cartridge only)	189	332
Charge 1 (ignition cartridge plus 1 increment charge).	292	784
Charge 2 (ignition cartridge plus 2 increment charges).	377	1,204

Charge	Muzzle velocity (fps)	Maximum range (yd)
Charge 3 (ignition cartridge plus 3 increment charges).	449	1,594
Charge 4 (ignition cartridge plus 4 increment charges).	518	1,990

**15. Cartridge, 60 Millimeter: Illuminating M83A3, M83A2, or M83A1, w/Fuze, Time (Fixed), M65A1 or M65**

*a. General.* The cartridge M83A3 (fig. 3) is for use in night missions requiring illumination for purposes of observation. The complete round consists of body tube assembly and tail assembly illuminant and parachute assembly, time fuze M65A1, fin assembly with propelling charge, ignition cartridge, and primer. The body is made of thin-walled steel tubing at the front end of which is welded a steel adapter threaded internally to seat the fuze. The tail assembly is a lightweight metal cone. The forward end of the cone is formed to provide a circular collar and a bourrelet. The collar is inserted into the body tube and held in position by four equally spaced shear pins. The base end of the cone is fitted with a fin adapter which holds the fin assembly. The fin assembly, propellant increment charges, ignition cartridge, and primer are identical with those used on the round described in paragraph 14. The illuminate assembly consists of quickmatch, black powder priming charge, first-fire composition, and main charge of illuminant composition held in a boxboard casing. The casing is attached to the parachute by an 18-inch suspension wire. In functioning, the fuze ignites the quickmatch (after approximately 14 seconds); the quickmatch in turn ignites the black powder expelling charge. The expelling charge ejects the parachute and illuminant charge assemblies from the base of the projectile, at the same time igniting the illuminant charge. The illuminant composition burns for at least 31 seconds, with a minimum candlepower of 330,000 candles. Its descent is at the rate of 10 feet per second. Cartridge M83A1 differs from the M83A3, only in the illuminant composition contained in the illuminant assembly, which has a burning time of 25 seconds and a minimum candlepower of 145,000 candles. Cartridge M83A1 may be assembled with fuze M65. Cartridge M83A2 is identical

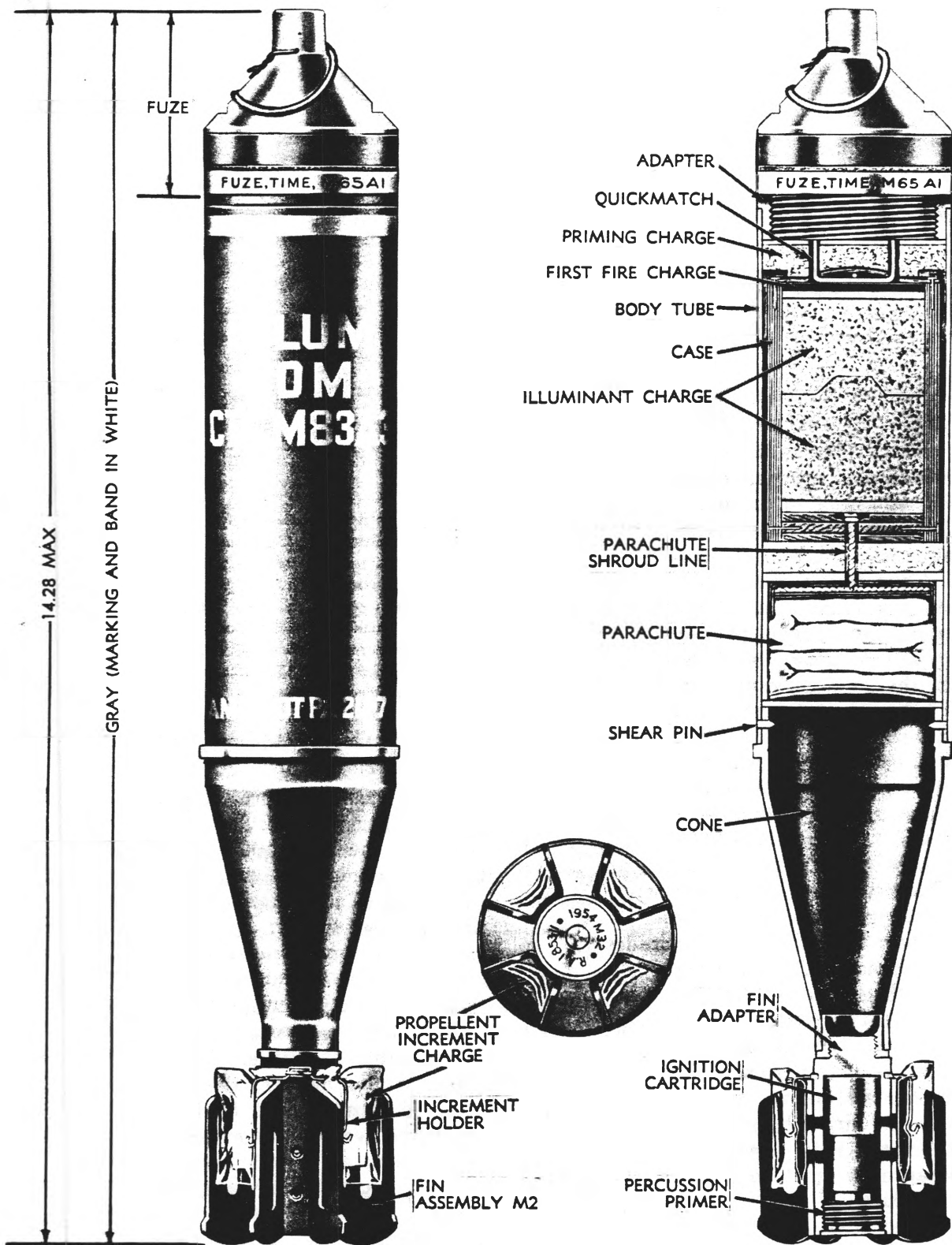

RA PD 80728F

Figure 3. Cartridge, 60 millimeter; illuminating, M83A3, w/fuze, time (fixed), M65A1.

with the M83A3 except for some minor dimensional changes in metal parts.

*b. Physical Data.*

Weight of complete round ----- 4.15 lb  
 Length of complete round ----- 14.28 in.

*c. Ballistic Data.*

Charge	Muzzle velocity (fps)	Horizontal range (yd)	Height of burst (yd)	Elevation deg	min
Charge 2 (ignition cartridge and 2 increment charges).	312	475	170	68	
Charge 2 (ignition cartridge and 2 increment charges).	312	500	157	66	45
Charge 2 (ignition cartridge and 2 increment charges).	312	525	145	65	30
Charge 3 (ignition cartridge and 3 increment charges).	374	875	152	51	45
Charge 4 (ignition cartridge and 4 increment charges).	434	1,100	175	45	15

**16. Cartridge, 60 Millimeter: Smoke WP, M302, w/Fuze, PD, M527A1 or M527**

Length of complete round ----- 11.07 in.

*c. Ballistic Data.*

*a. General.* This cartridge (fig. 4) is for use in spotting and producing screening smoke. It is of an assembly consisting of projectile M302, PD fuze M527A1, M527B1, M527A1B1, or M527, fin assembly M2, propellant increment charge M3A1 (four increments), ignition cartridge M5A1, and percussion primer M32. The fin assembly, percussion primer, and ignition cartridge are the same, and function the same as in the high-explosive cartridge M49A2 (par. 14). The projectile is a relatively thin-walled steel casing having cylindrical side walls and a conical base, which is internally threaded to receive the fin assembly. The projectile nose is fitted with a steel adapter that is threaded to receive the fuze, and also serves to hold the sleeve of the burster casing M8. Burster charge M19, containing 165 grains of tetryl, is used with this projectile. (Refer to par. 81 for description of this burster.) In functioning, the burster which extends axially three-quarters of the length of the projectile cavity, bursts the projectile, thereby releasing and dispersing the 0.765-pound filler of white phosphorus. The white phosphorus ignites and burns spontaneously on contact with the air. The PD fuze M527A1 or M527 functions with superquick action. Refer to paragraphs 36 through 59 for description of these fuzes.

Charge	Muzzle velocity (fps)	Maximum range (yd)
Charge 0 (ignition cartridge only)	156	244
Charge 1 (ignition cartridge plus 1 increment charge)	244	570
Charge 2 (ignition cartridge plus 2 increment charges)	316	912
Charge 3 (ignition cartridge plus 3 increment charges)	380	1,260
Charge 4 (ignition cartridge plus 4 increment charges)	439	1,610

**17. Projectile, 60 Millimeter: Training, M69 (w/o Fin Assembly)**

*a. General.* This projectile (fig. 5) is provided for training in loading and firing the mortar. The projectile without ignition cartridge is completely inert and has no fuze. It consists of a cast-iron pear-shaped body and is assembled with fin assembly M2 (modified) or M5. No propellant increment charges are used with this training projectile. The ignition cartridge M4 or the combination of ignition cartridge M5A1 and percussion primer M32 is used in firing the projectile. Unlike other ammunition for the mortar, the four components are issued separately to facilitate replacement of damaged, wornout, or expended parts. Ten training projectiles and accessories are packed in an equipment training kit for field use. To overcome difficulties encountered in extracting fired ignition cartridges M4 after firing the round, modification of the fin assembly M2 (when this service-type fin is used) is authorized for field

*Note.* Some rounds with fuzes of the M82-series, some of which are on hand, are issued for emergency combat only.

*b. Physical Data.*

Weight of complete round ----- 3.98 lb

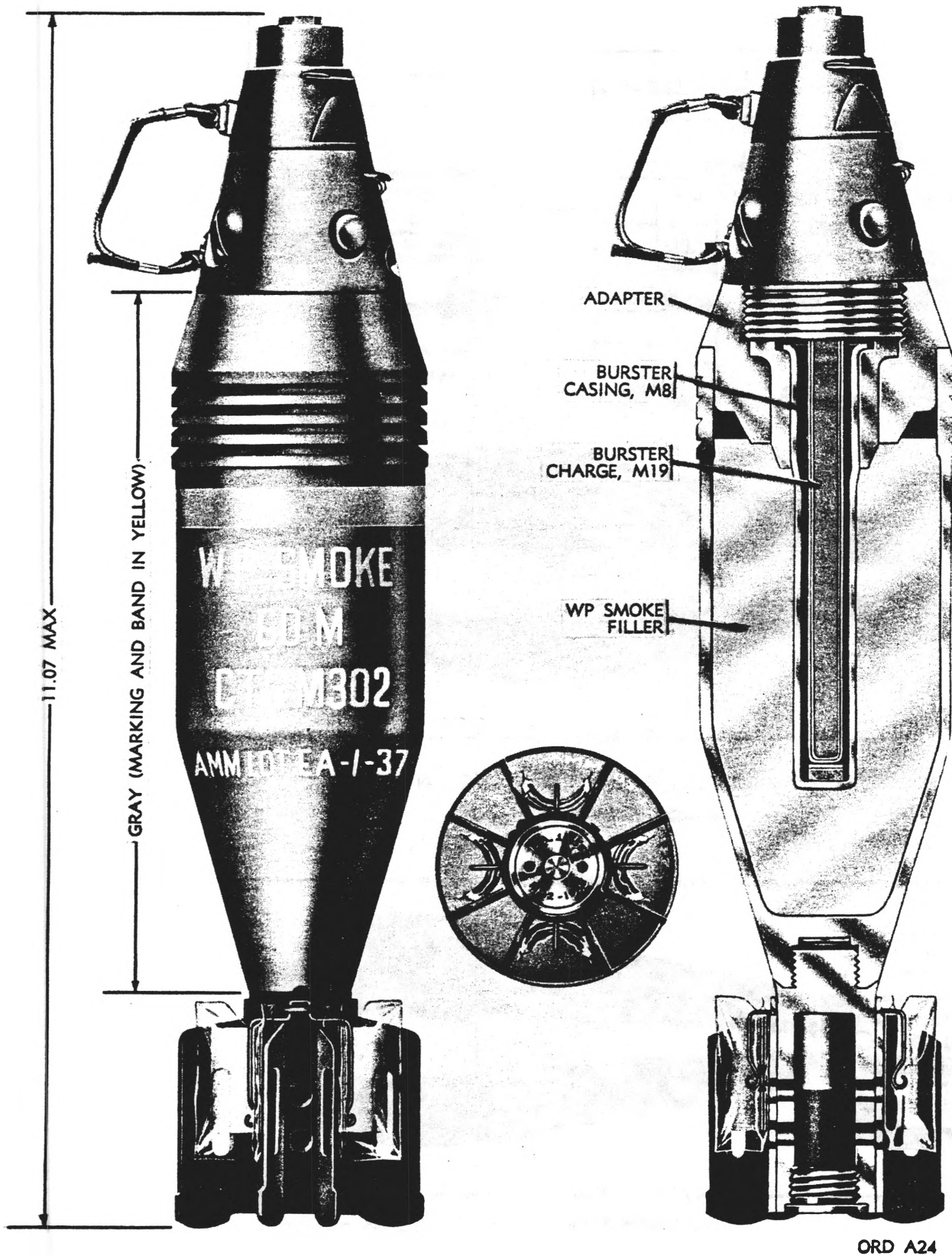
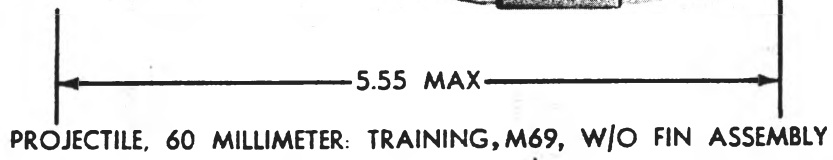
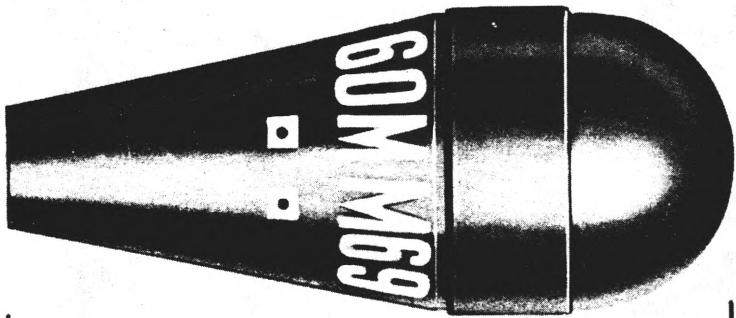
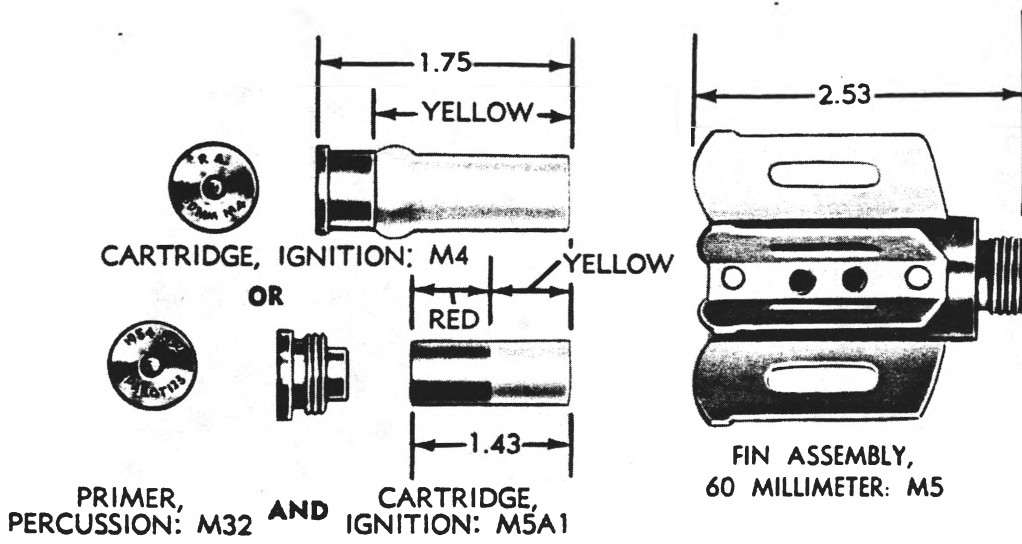

Figure 4. Cartridge, 60 millimeter: smoke, WP, M302, w/fuze, PD, M527A1.



**A—COMPONENTS**

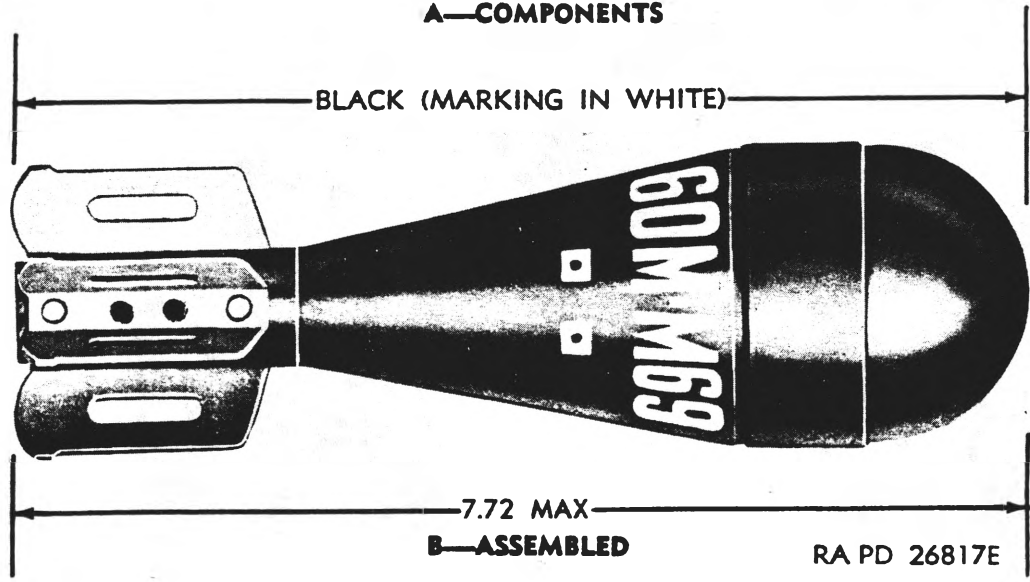

Figure 5. Projectile, 60 millimeter: training, M69.

operation. The modification consists of drilling a 3/8-inch diameter hole axially through the fore (threaded) end of the fin shaft. A small steel rod or punch with a blunt point can then be driven through the hole to eject the fired ignition cartridge. Fin M5 has this hole in it as issued. When the ignition cartridge M5A1 is used in firing, the cartridge is removed with long nose pliers which are issued for the purpose. When using modified fins, the lead seals of ignition cartridges may lodge in the threaded recess in the base of the projectile, resulting in progressive filling of the recess. Insecure seating of the fin and

excessive vibration as a result may, under such conditions, cause the threaded portion at the base of the projectile to crack or break off. The condition can be corrected by cleaning out the projectile recess or prevented by inserting a thin steel disk ahead of the ignition cartridge.

*b. Data.*

Weight of complete round -----	4.43	lb
Weight of projectile, w/o fin -----	3.95	lb
Length of complete round -----	7.72	in.
Length of projectile, w/o fin -----	5.55	in.
Muzzle velocity -----	152.5	fps
Maximum range -----	235	yd

## Section II. CARTRIDGES FOR 81-MM MORTAR CANNONS M1 AND M29

### 18. General

*a. Description.* The 81-mm mortars M1 and M29 are smoothbore, muzzle-loading high-angle fire weapons. The barrel or tube is assembled into a single unit with a fixed firing pin in the base for "drop-firing." The mount consists of two units—the bipod and base plate. The mortar M1 differs from the mortar M29 in that the barrel of the M1 has a smooth outer surface and a base plate which has three seats for the spherical projection of the mortar base cap. The barrel of the mortar M29 has outer threads for adjustment of elevation. The base plate has one socket for placement of the mortar base cap. All the cartridges that are authorized for use in the 81-mm mortar M1 are also authorized for use in the 81-mm mortar M29. Although the high-explosive cartridge M362 and the WP smoke cartridge M370 are also authorized for use in the 81-mm mortar M1, not more than five increment charges for the M362 and not more than six increment charges for the M370 may be used in mortar M1. A warning label to this effect appears on each cartridge. Some rounds of earlier manufacture may bear a label stating "not more than six increments" etc.; this must be disregarded as more than five increments on this cartridge in mortar M1 is prohibited. Cartridge HE M362 and cartridge smoke WP M370 with full charge of eight increments are authorized for firing from mortar M29.

*b. Identification.* The characteristic shape, the grooved area of the cartridge body between the tail and the bourrelet, except for the illuminating cartridge M301A1 or M301A2 and the high-explosive cartridge M362, and the use of the fin assembly to hold a propelling charge as well as to provide stability in flight are identifying features of 81-mm mortar ammunition. Painting and marking for identification are in accordance with the basic color scheme prescribed in TM 9-1900. See also figures 6 through 12.

*c. Projectile.* Dependent upon type of projectile, ammunition for these mortars is classified as high-explosive (HE), illuminating, smoke (FS) or (WP), target-practice (TP), and training.

*d. Fuze.* Three types of point fuzes are used with 81-mm ammunition: impact, time, and proximity. Descriptions of these types and rounds with which each type is used are given in (1), (2), and (3) below. For additional information on these fuzes, refer to paragraphs 36 through 59 and fuze interchangeability chart (par. 36).

(1) *Impact.* The PD fuze M53A1, single-action delay type, is used with cartridges M56 and M56A1. The PD fuze M524, which is a superquick or delay type, is used with the HE cartridge M362 and the smoke (WP) cartridge M370. The PD fuze M524 is replacing the PD fuze M519. The

PD fuzes M525A1 and M525, single-action superquick types, are used with the HE and TP cartridges M43A1, HE cartridges M56 and M56A1, and smoke cartridges (WP) M57 and (WP or FS) M57A1. The PD fuzes M525 series is replacing the PD fuzes M52 series (M52, M52A1, M52A2, M52A2B1, and M52B10). As an interim measure, PD fuzes M52 series modified by replacing the tetryl booster with a black powder charge may be used with the TP cartridge M43A1 for training only. The PD fuze M526A1 is used with the HE cartridge M362A1 or M362 and the smoke (WP) cartridge M370. The TSQ fuze M77, a selective superquick or time fuze, is used with the HE cartridge M56A1 and smoke WP cartridges M57 and M57A1.

*Note.* High-explosive, smoke, and TP cartridges fitted with PD fuzes M52-series (not modified), M82-series, and M519-series are to be used for emergency combat only.

**WARNING: Do not fire cartridges fitted with M52-series, M82-series, and M519-series fuzes over the heads of friendly troops.**

- (2) *Graduated-time.* Fuze M84 is a powder-train time fuze used with the 81-mm illuminating cartridges M301A1 and M301A2. It has a graduated time scale for time settings up to 25 seconds.
- (3) *Proximity.* The proximity fuze M517 is used with the high-explosive cartridge M362. Preparation of the cartridge M362 for firing with proximity fuzes should be in accordance with steps (a) through (g) below.
  - (a) Place the round on its side.
  - (b) Insert fuze wrench M18 in the wrench slots of the fuze and strike the wrench handle sharply in a counterclockwise direction (fuze is assembled to the projectile with right-hand threads) to loosen the fuze from the projectile, taking care not to strike any part of the fuze. Unscrew and remove the fuze.

- (c) Inspect the cavity for damage. Remove any loose material from the cavity. If any high explosive is found adhering to the threaded portion of the projectile throat, remove it with a pointed instrument made of wood or a nonferrous metal.
- (d) Examine the projectile nose threads and the fuze threads to insure that they are in good condition. Do not use components with damaged threads.
- (e) Screw in the proximity fuze (with wavy spring washer in proper position) by hand (fuze has right-hand threads). If binding occurs, inspect the fuze cavity and threads on both fuze and projectile. Reject whichever is at fault.
- (f) Tighten the fuze (and its washer) to the projectile, so that no clearance exists between the fuze, washer, and the projectile, by using fuze wrench M18. Use only such force as can be applied by hand to the fuze wrench handle. If fuze wrench is not available, tighten securely by hand so that the wavy spring washer is completely compressed and that no air gap remains between fuze and projectile body. Loose fuzes may cause a high percentage of malfunction. *Do not hammer on the wrench or use an extension handle on it. Do not stake the fuze to the projectile under any circumstances.*
- (g) If not fired, the fuzes and the rounds should be restored to their original condition and packings.

*e. Propelling Charge.* The full propelling charge for 81-mm mortar cartridges, except for training cartridges ( (2) below), consists of an ignition cartridge and propellant increment charges as indicated below and in table I. Any or all of the propellant increment charges may be removed for adjustment of fire in accordance with appropriate firing tables.

- (1) *Propelling charge for high-explosive, smoke, and target-practice cartridges.*
  - (a) *Ignition cartridge.* Dependent upon

model of cartridge, either ignition cartridge M3, M6, M8, or M66 is used with 81-mm cartridges, as listed in table I, when firing charge O. When firing other than charge O, the ignition cartridge also serves to ignite the propellant increments.

- (b) *Propellant increment charge.* Dependent upon model of cartridge, either propellant increment charge M1A1, M2A1, or M5 is used with 81-mm cartridges as listed in table

I. Six charges M1A1, four charges M2A1, or eight charges M5 are for adjustment of fire (charge firing). To adjust an increment charge for "charge" firing, it is only necessary to remove the propellant increments not required from the increment holder.

- (2) *Propelling charge for training cartridges.* The full propelling charge for the training cartridge M68 consists only of ignition cartridge M3 or ignition cartridge M6.

Table I. Propelling Charge Data

Model of cartridge	Cartridge ignition:**	Propelling charge*	
		Charge, propellant increment:	Number of increments
M43A1 -----	M6 or M8	M1A1	6
M56 and M56A1, M57 and M57A1, or M301A1, and M301A2.	M6	M2A1	4
M362 and M370 -----	M66 ---	M5	8
M68 *-----	M3 or M6	None required	

\* Refer to paragraphs 60 through 63 for additional information on propelling charges.

\*\* Refer to paragraphs 64 through 74 for additional information on ignition cartridges.

f. *Primer.* The percussion primer M34, a threaded screw-in type, is used to ignite either the ignition cartridge M6 or M8. The percussion primer M71, a threaded screw-in type, is used to ignite the ignition cartridge M66. When firing training cartridge M68 with ignition cartridge M3, no separate primer is required since this ignition cartridge contains a primer in its base. Refer to paragraphs 64 through 74 for additional information on primers.

g. *Fin Assembly.* The fin assembly M3 is used with the HE and TP cartridges M43A1. The training cartridge M68 uses the fin assembly M6. The HE cartridges M56 and M56A1, the WP or FS smoke cartridges M57 and M57A1, and the illuminating cartridges M301A1 and M301A2 use the fin assembly M4 or M4A1. The HE cartridge M362 and smoke (WP) cartridge M370 utilize the fin assembly

M141. Refer to paragraphs 19, 20, 21, and 27 for additional information on these fins.

h. *Packing and Shipping Data.* Dependent upon type of cartridge, 81-mm ammunition, except for training projectiles, are packed one complete round per fiber container and one, two, three, four, or six containers per wooden or metal box. Training projectiles are packed 1, 8, or 18 projectiles (without fiber containers) per paper-lined or metal-lined wooden box, or solid fiberboard box. For additional information on packing of 81-mm ammunition, refer to paragraph 11 and SM 9-5-1315.

19. Cartridge, 81 Millimeter: HE, M43A1 or M43A1B1, w/Fuze, PD, M525A1 or M525

a. *General.* This cartridge (fig. 6) is a lightweight round for use against light materiel targets and personnel, functioning with both fragmentation and blast offset. The complete round consists of a relatively thinwalled shallow-cavity steel projectile containing a

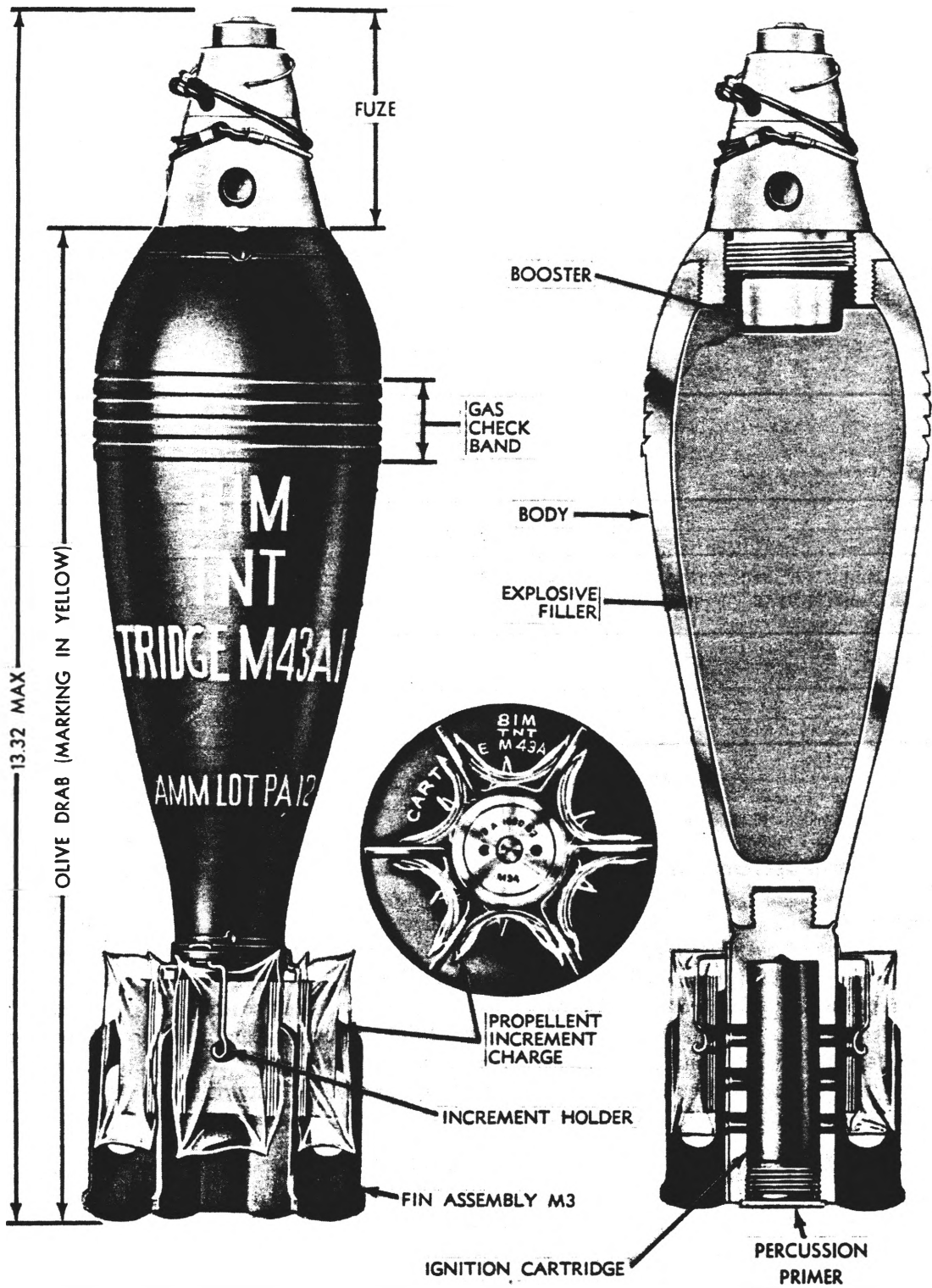

RA PD 80770D

Figure 6. Cartridge, 81 millimeter: IIE, M43A1, w/fuze, PD, M525.11.

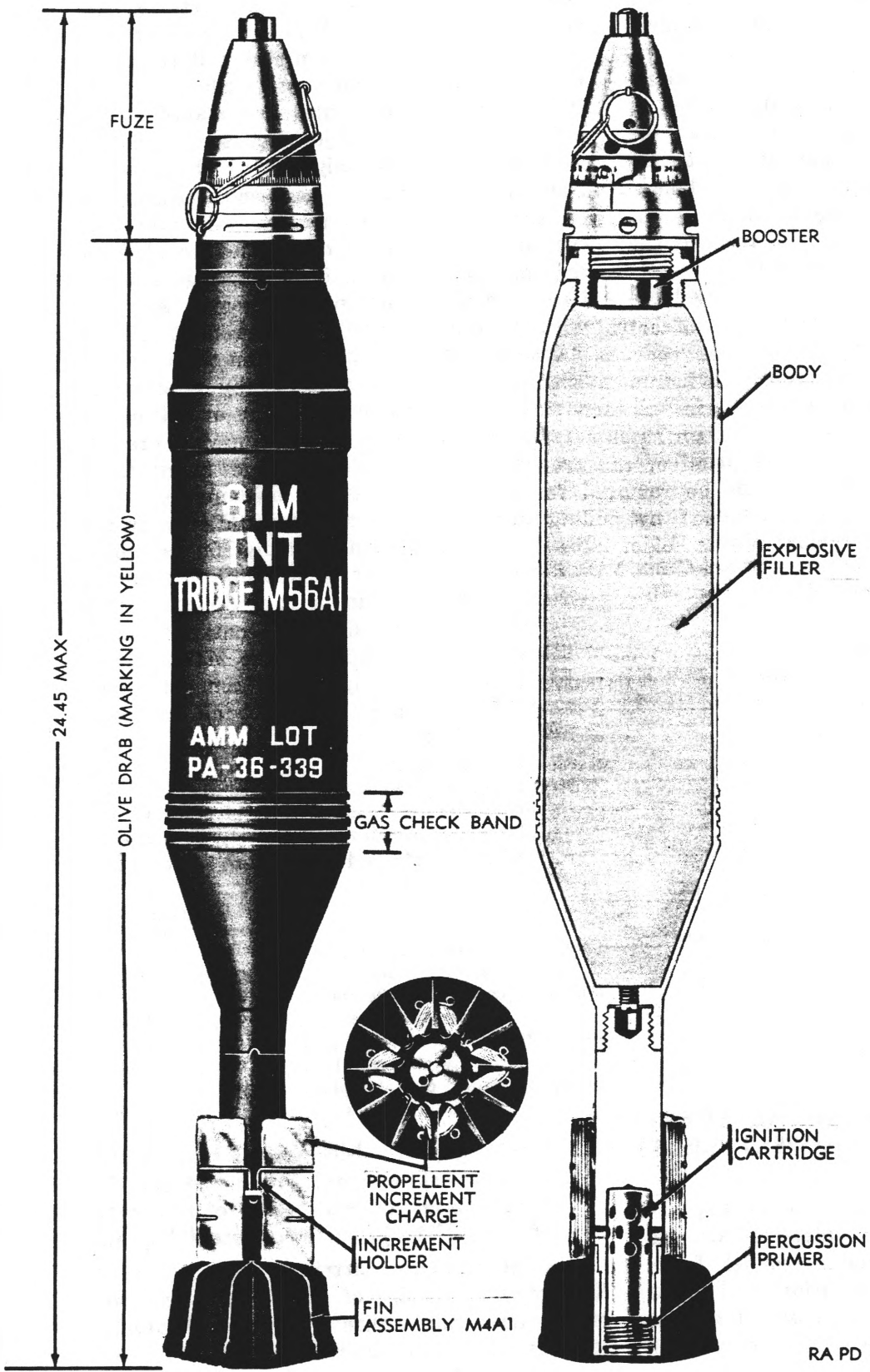

RA PD 80771D

Figure 7. Cartridge, 81 millimeter: HE, M56A1, w/fuze, TSQ, M77.

TNT bursting charge, PD fuze M525 series, a fin assembly M3 with propellant increment charges M1A1, ignition cartridge M6 or M8, and percussion primer M34. At time of manufacture, the fuze is assembled and staked to the internally threaded projectile nose; the fin assembly is assembled and staked to the internally threaded projectile base. The hollow perforated fin assembly shaft, which is internally threaded at its base end, receives the ignition cartridge and the screw-in type percussion primer. The perforations provided for transmission of the ignition cartridge flash to the propellant increment charges. A cellophane-wrapped propellant increment charge is inserted between the blades of each fin and held in position by a spring-clip type increment holder. Any or all of the propellant increment charges may be removed for fire adjustment (charge firing) by pulling them from under the increment holder clips.

*Note.* Rounds on hand fitted with M52-series fuzes are issued for emergency combat only.

*b. Physical Data.*

Weight of complete round (with PD fuze M525A1) (w/o safety wire propellant charge) 7.15 lb  
 Length of complete round 13.32 in.

*c. Ballistic Data.*

Charge	Maximum range (yd.)
Charge 0 (ignition cartridge only)	500
Charge 1 (ignition cartridge plus 1 increment charge)	1,000
Charge 2 (ignition cartridge plus 2 increment charges)	1,550
Charge 3 (ignition cartridge plus 3 increment charges)	2,000
Charge 4 (ignition cartridge plus 4 increment charges)	2,475
Charge 5 (ignition cartridge plus 5 increment charges)	2,900
Charge 6 (ignition cartridge plus 6 increment charges)	3,300

**20. Cartridge, 81 Millimeter: HE, M56A1 or M56, w/Fuze, PD, M525A1, M525, M53A1, or TSQ, M77**

*a. General.* The cartridge M56A1 (fig. 7) is a high-explosive round intended for use against materiel targets and personnel, functioning with both fragmentation and blast effect. The complete round consists of a relatively thin-walled shallow-cavity steel projectile containing a TNT bursting charge, a point fuze, a fin assembly M4A1 with propellant in-

crement charges M2A1, ignition cartridge M6, and percussion primer M34. At time of manufacture, the fuze is assembled and staked to the internally threaded projectile nose; the fin assembly is assembled and staked to the internally threaded projectile base. The hollow perforated fin assembly shaft, which is internally threaded at its base end, receives the ignition cartridge and the screw-in type percussion primer. The perforations provided for transmission of the ignition cartridge flash to the propellant increment charges. A cellophane-wrapped propellant increment charge is inserted between the blades of each fin and held in position by a spring-clip-type increment holder. Any or all of the propellant increment charges may be removed for fire adjustments (charge firing) by pulling them from under the increment holder clips. The cartridge M56 differs from the cartridge M56A1, only in the fin assembly M4 assembled to the projectile. The fin assembly M4 differs from the M4A1 in that it is of die-cast aluminum base alloy containing a cold-drawn steel liner, whereas the M4A1 is of die-cast aluminum base alloy composition with an aluminum-alloy rod shank in place of the cold-drawn steel liner.

*b. Physical Data.*

Weight of complete round (w/TSQ fuze M77) (w/o safety wire and propellant charge) 11.40 lb  
 Length of complete round (w/TSQ fuze M77) 24.45 in.

*c. Ballistic Data (Assembled w/TSQ Fuze M77).*

Charge	Maximum range (yd.)
Charge 1 (ignition cartridge plus 1 increment charge)	800
Charge 2 (ignition cartridge plus 2 increment charges)	1,400
Charge 3 (ignition cartridge plus 3 increment charges)	1,900
Charge 4 (ignition cartridge plus 4 increment charges)	2,486

**21. Cartridge, 81 Millimeter: HE, M362 (T28 series), w/Fuze, PD, M524 (or PD M526 series or PD M519 or Proximity M517 (T178E3)), or w/o Fuze (Plugged)**

*a. General.* This cartridge (fig. 8) is a lightweight cartridge of new design. The cartridge does not utilize gas check bourrelet grooves which characterize cartridges of earlier design. The cartridge consists of a point-fuzed, Composition B loaded projectile, a car-

tridge housing which houses the ignition cartridge and holds the propellant increments, and a fin which contains the percussion primer.

b. *Firing Data.* Firing data for the 81-mm mortars M1 and M29, firing cartridge HE M362, with fuze PD M519 (T319) or proximity fuze M517 (T178E3) are published in FT 81-Z-2 (Abr).

c. *Description.* Physical characteristics of the cartridge are described in (1) through (6) below.

- (1) *Complete round.* The complete round M362 is 20.798 inches maximum in overall length and weighs 9.47 pounds. Markings on the projectile indicate the caliber and type of weapon in which used, model designation of the round, type of filler, and the ammunition lot number. A warning label, reading "WHEN FIRING IN THE 81-MM MORTAR M1, USE NOT MORE THAN FIVE INCREMENTS" appears on the projectile. Cartridges of earlier manufacture may be found on hand bearing warning labels indicating the use of not more than six increments when firing in the mortar M1. However, this limitation of six increments should be disregarded since the use of more than five increments in the mortar M1 is prohibited.
- (2) *Projectile.* The projectile M362 has an approximate loaded weight of 7.20 pounds including the bursting charge of approximately 2.10 pounds of Composition B.
- (3) *Fin assembly.* The fin assembly M141 consists of the cartridge housing, the fin, and the increment holders. The cartridge housing is made of an aluminum alloy rod which is drilled, shaped, perforated, and threaded to receive the ignition cartridge at the forward end and threaded to receive the fin at the rear end. The perforations provide for the transmission of the cartridge flash to the propellant increments. A drilled central flash hole is also provided for transmission of primer flash to ignition

cartridge. The fin is made of cast aluminum alloy. It is drilled and threaded internally to receive the screw-in type percussion primer. The steel wire increment holders have kidney-shaped projections for holding the increments of propellant. One increment holder fits between the cartridge housing and the projectile; the other holder fits between the cartridge housing and the fin.

- (4) *Primer.* PRIMER PERCUSSION: M71E1 is similar to the PRIMER, PERCUSSION: M34 used in 81-mm mortar cartridges of earlier design, except that the exterior configuration has been changed to enable assembling into the hub of the fin.
- (5) *Ignition cartridge.* CARTRIDGE, IGNITION: M66 is used with this cartridge. The ignition cartridge body is formed from standard commercial paraffined cartridge paper with the outer layer colored half red and half yellow and an inner —layer of two 0.005-inch thick brass liners to increase the confinement. The ignition charge consists of 115 grains of ignition powder M9. The cartridge is placed in the cartridge housing with the red end toward the primer (the rear of the round). This arrangement is necessary because the red portion of the cartridge contains a paper flash tube which extends to approximately half the length of the cartridge body. The purpose of the flash tube is to permit the flash from the primer to ignite the ignition charge down to its center, thereby producing better and more uniform ignition.
- (6) *Propelling charge.* The propelling charge consists of a total of 1,280 grains of 0.010-inch web propellant M9 in flake form, which is divided into 8 increments of 160 grains each. Each increment charge is contained in a paraffin wax-treated grade C cotton cloth bag having a buttonhole on each end. The bags are attached to the projectile by engaging the but-

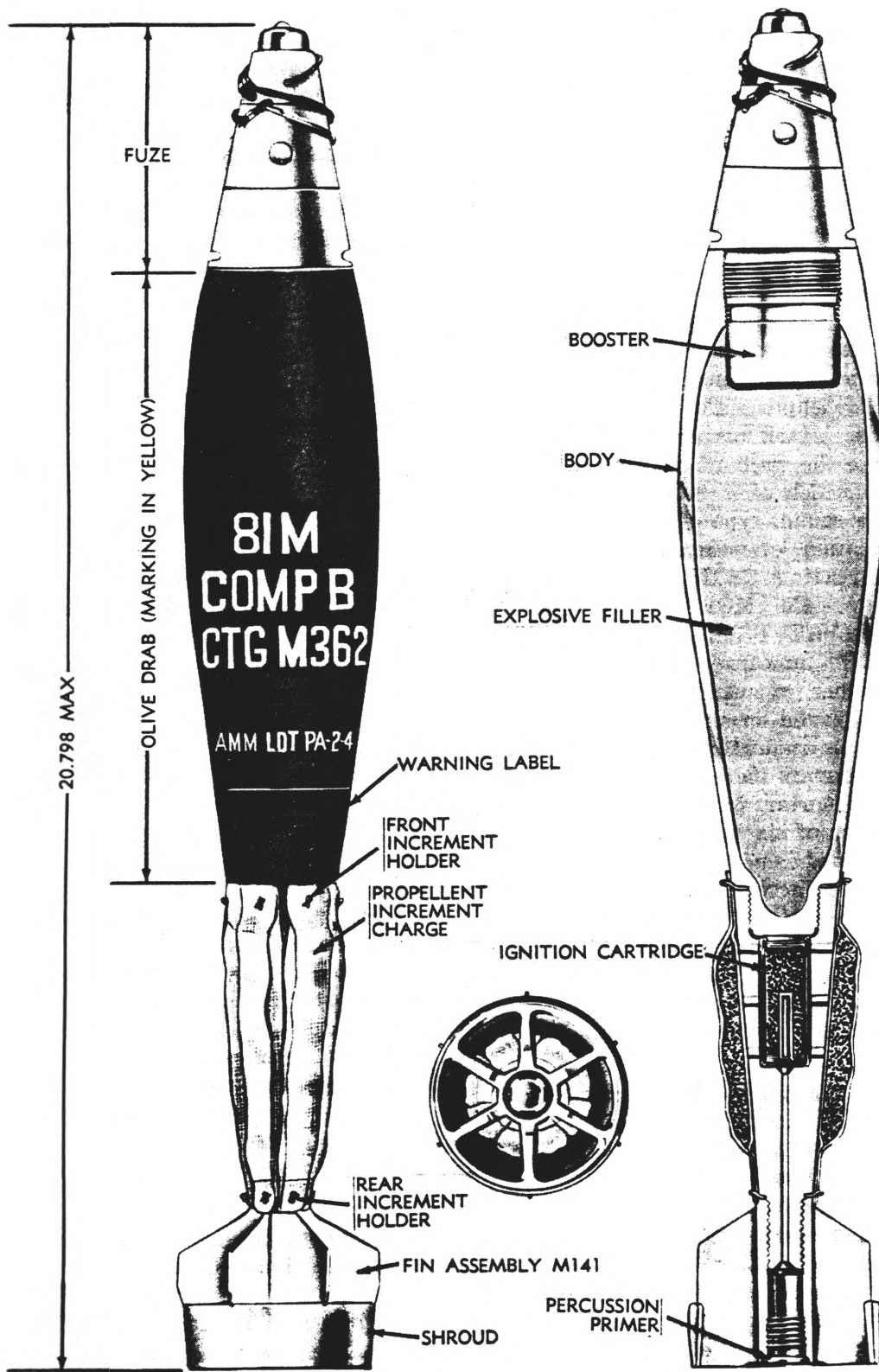

RA PD 253471A

Figure 8. Cartridge, 81 millimeter: HE, M362, w/fuze, PD, M526-11.

tonholes over the kidney-shaped projections of the increment holders.

*d. Functioning.* The functioning of the cartridge is the same as earlier types of 81-mm mortar cartridges. The cartridge is dropped into the mortar tube from the muzzle end. The primer in the hub of the fin functions on striking the firing pin in the base cap of the mortar. The fired primer flashes through the central flash hole in the ignition cartridge housing, thereby igniting the ignition cartridge. The ignition cartridge, in turn, flashes through the flash holes in the wall of the housing to ignite the propelling charge. The pressure thus created by the ignition cartridge and propelling charge forces the cartridge out of the mortar tube.

*e. Preparation for Firing.* After removal from packing materials, the cartridge must be prepared for firing as indicated in (1) through (4) below.

- (1) Inspect the round for possible damage to the fuze, propelling charge, and fin assembly.
- (2) Remove any undesired propelling charge increments if round is to be fired with less than full propelling charge.
- (3) If round is to be fired with the single action PD fuze M519, which is to be used for emergency combat only, it is only required to remove safety wire before firing.
- (4) If proximity fuze is to be used, remove the PD fuze M519 with fuze wrench M18 and replace it with proximity fuze M517 (T178E3) by the method indicated in (a) through (d) below.

(a) Remove the proximity fuze from its container.

**CAUTION: Do not remove the wavy spring washer from the relief under the fuze shoulder.**

- (b) Examine the fuze threads to insure that they are in good condition. Do not use components with faulty threads.
- (c) Insert the fuze (with wavy spring washer in proper position) into the fuze cavity of the projectile and screw the fuze in manually by

grasping the metal portion (base) of the fuze.

- (d) Tighten the proximity fuze (and its washer) to the projectile so that no clearance exists between the fuze, washer, and the projectile by using fuze wrench M18. If fuze wrench is not available, tighten securely by hand so that the wavy spring washer is completely compressed and that no air gap remains between fuze and projectile body. Loose fuzes may cause a high percentage of malfunctions.

*Note.* Do not stake the fuze to the projectile and do not attempt to set the fuze.

*Note.* The high-explosive cartridge M362 is also issued with fuze PD M524 and a spotting charge for target-practice purposes, or with proximity fuze M517 or with PD fuze M526A1 and with red, yellow, or green barater burster. Any rounds on hand fuzed with PD fuze M519 are to be used for emergency combat only.

**WARNING: When firing the cartridge M362 in the 81-mm mortar M1, not more than five propellant increment charges may be used. A warning label to this effect appears on the cartridge.**

*f. Physical Data.*

Weight of complete round (w/PD fuze M526A1) -----	9.42 lb
Length of complete round (w/PD fuze M526A1) -----	20.798 in.

*g. Ballistic Data.*

Charge	Maximum range (yd)
Charge 0 (ignition cartridge only) -----	300
Charge 1 (ignition cartridge plus 1 increment charge) -----	700
Charge 2 (ignition cartridge plus 2 increment charges) -----	1,300
Charge 3 (ignition cartridge plus 3 increment charges) -----	1,850
Charge 4 (ignition cartridge plus 4 increment charges) -----	2,350
Charge 5 (ignition cartridge plus 5 increment charges) (maximum increment charges authorized for use when firing in the mortar M1) -----	2,700
* Charge 6 (ignition cartridge plus 6 increment charges) -----	3,200
Charge 7 (ignition cartridge plus 7 increment charges) -----	3,600
Charge 8 (ignition cartridge plus 8 increment charges) -----	3,897

**22. Cartridge, 81 Millimeter: Illuminating, M301A1 or M301A2, w/Fuze, Time, M84**

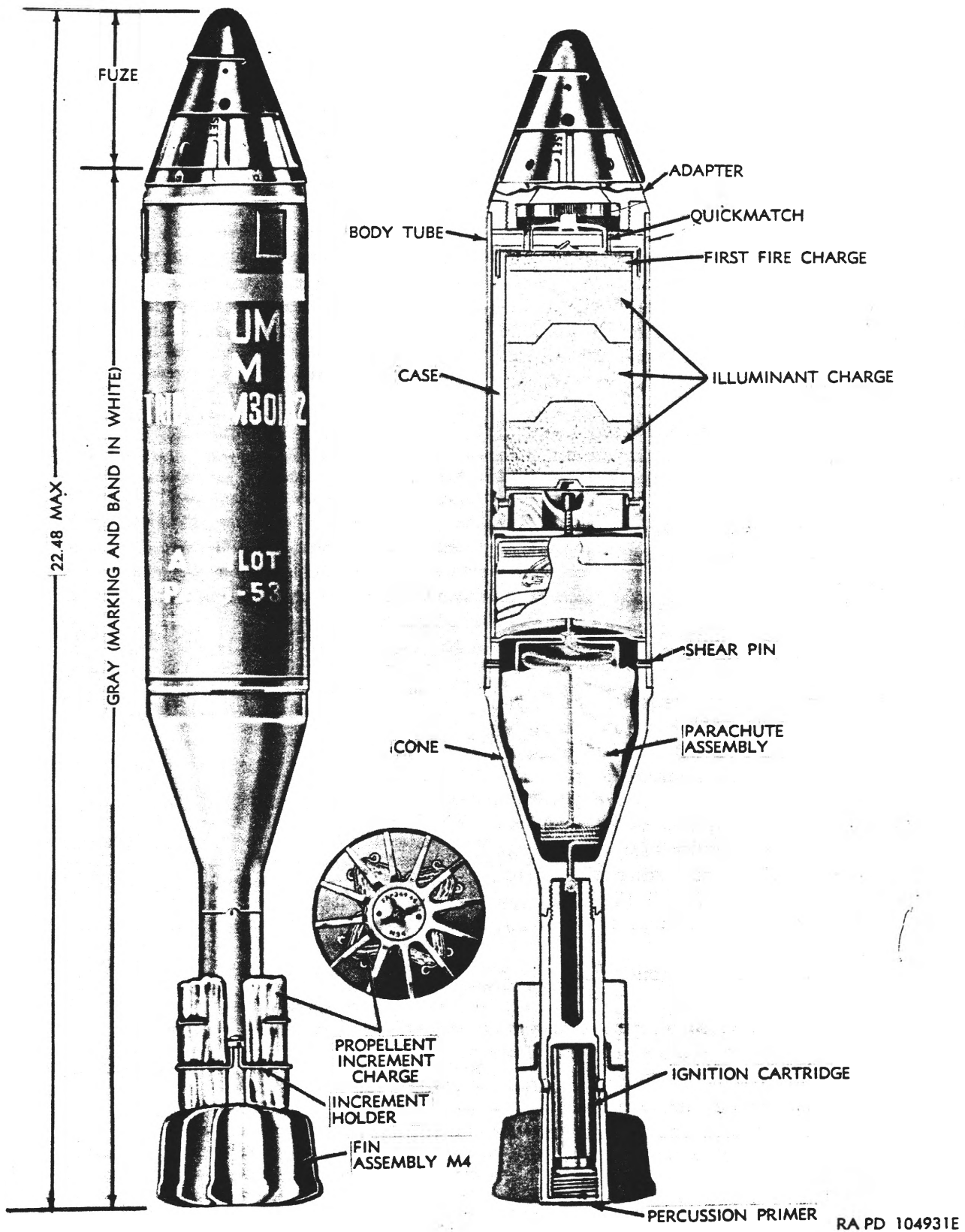

Figure 9. Cartridge, 81 millimeter: illuminating, M301A2, w/fuze, time, M81

a. *General.* The cartridge M301A2 (fig. 9), similar in design to the 60-mm illuminating cartridge M83-series, is intended for illuminating a desired point or area. The complete round consists of time fuze M84, a thin-walled steel body tube assembly, a parachute assembly, steel tail cone, a fin assembly M4 containing propellant increment charges M2A1, ignition cartridge M6, and percussion primer M34. The body is made of thin-walled steel tubing to the front end of which is assembled an internally-threaded steel adapter to seat the fuze. The tail cone is inserted into the body tube and is held in position by four equally spaced shear pins. The base end of the cone is fitted with an internally threaded adapter for insertion of the fin assembly. The illuminant assembly consists of a first fire charge and an illuminant charge contained within a boxboard case. A quick-match assembly is pasted at the forward end of the boxboard case. The

parachute assembly is attached to the illuminant assembly casing by a 30-inch long steel suspension wire. Upon functioning of the fuze, the fuze expelling charge ejects the parachute and illuminant assemblies through the base of the projectile, at the same time igniting the quick-match. The quick-match ignites the first fire charge which lights the illuminant composition. The illuminant composition burns for at least 75 seconds, with a minimum of 500,000 candlepower. Rate of descent is approximately 12 feet per second. The illuminating cartridge is intended to be fired only with two, three, or four propellant increment charges. The illuminating cartridge M301A1 is similar to the cartridge M301A2 except that it has gas check bourrelet grooves and some minor dimensional differences in metal parts.

b. *Physical Data.*

Weight of complete round ----- 10.71 lb.  
 Length of complete round ----- 22.48 in.

c. *Ballistic Data.*

Charge	Fuze setting (sec)	Horizontal range (yd)	Height of burst (yd)	Elevation	
				deg	min
Charge 2 (ignition cartridge plus 2 increment charges) (minimum charge authorized).	4.0	100	450	79	15
Charge 2 (ignition cartridge plus 2 increment charges) (minimum charge authorized).	4.5	100	500	79	15
Charge 2 (ignition cartridge plus 2 increment charges) (minimum charge authorized).	16.3	1,000	450	62	30
Charge 3 (ignition cartridge plus 3 increment charges).	17.8	1,700	450	52	45
Charge 4 (ignition cartridge plus 4 increment charges).	20.6	2,300	450	51	15

23. Cartridge, 81 Millimeter: Smoke, WP, M57 or FS or WP, M57A1, w/Fuze PD, M525A1, M525, or TSQ, M77

a. *General.* The WP cartridge M57A1 (fig. 10) is intended for producing a screening smoke. The complete round consists of a relatively thin-walled steel projectile body containing a white phosphorous smoke filler, a point fuze, a fin assembly M4A1, propellant increment charges M2A1, ignition cartridge M6, and percussion primer M34. The nose of the projectile is provided with a steel adapter which serves as a seal for the chemical filler and as a seat for the burster assembly. The burster assembly consists of burster charge M1 and burster casing M2. The burster charge M1 is a thin-walled steel tube

filled with a small charge of tetryl. The burster charge is held in burster casing M2 which is press-fitted into the steel nose adapter of the projectile and extends axially through the chemical filler approximately three-fourths of the length of the projectile cavity. The burster charge ruptures the projectile body and disperses the chemical filler upon functioning of the fuze. This cartridge may also be loaded with FS, a liquid smoke producer, which acts spontaneously upon contact with air. The WP cartridge M57 differs from the WP cartridge M57A1 only in the fin assembly M4 assembled to the projectile in the M57 model. The fin assembly M4 differs from the M4A1 only in manufacturing details.

*Note:* Rounds on hand fitted with M52-series fuzes are issued for emergency combat only.

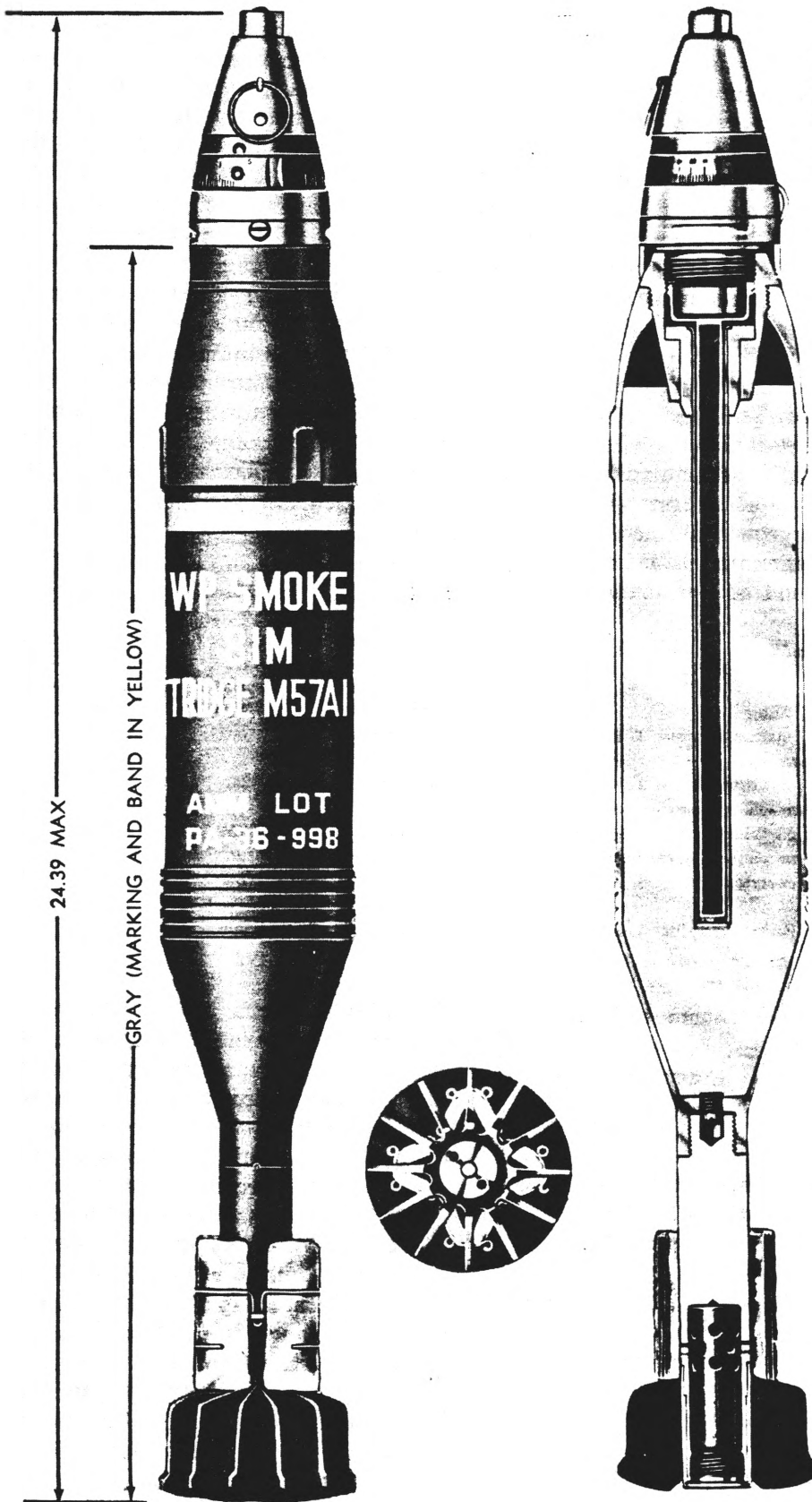

Figure 10. Cartridge, 81 millimeter: Smoke, WP, M57.11, w/fuze, TSQ, M77.

*b. Physical Data.*

Weight of complete round (w/TSQ fuze M77) -----	12.46 lb.
Length of complete round (w/TSQ fuze M77) -----	24.39 in.

*c. Ballistic Data.*

Charge	Maximum range (yd)
Charge 1 (ignition cartridge plus 1 increment charge) -----	700
Charge 2 (ignition charge plus 2 increment charges) -----	1,300
Charge 3 (ignition cartridge plus 3 increment charges) -----	1,800
Charge 4 (ignition cartridge plus 4 increment charges) -----	2,372

**24. Cartridge, 81 Millimeter: Smoke, WP, M370 (T30E9), w/Fuze, PD, M524**

*a. General.* This cartridge (fig. 11) is a lightweight cartridge intended for producing a smoke screen. The cartridge consists of a thin-walled projectile containing a white phosphorous smoke filler, a point fuze, fin assembly M141, propellant increment charges M5, ignition cartridge M66, and percussion primer M71. The projectile does not have gas check bourrelet grooves. The nose of the projectile is provided with an adapter and the base is provided with a base adapter. The adapter and base adapter serve as seals for the smoke filler. The adapter also serves as a seat for the burster assembly. Burster assembly M47 consists of burster charge and burster casing. It is a thin-walled aluminum or steel tube filled with a small charge of RDX. The burster charge is held in the burster casing which is press-fitted into the steel adapter of the projectile and extends longitudinally through the smoke filler approximately three-fourths of the length of the projectile cavity. The burster charge ruptures the projectile body and disperses the smoke filler upon functioning of the fuze. The fin assembly (cartridge housing, fin, and front and rear increment holders), ignition cartridge, eight propellant increment charges, and percussion primer are identical with those used in the HE 81-mm cartridge M362, as described in paragraph 21.

*Note.* Point detonating fuze M526A1 (or M526) or proximity fuze M517 are alternative fuzes which may also be used with this round.

**WARNING:** When firing the cartridge M370 in the 81-mm mortar M1, not more than six propellant increments may be used. A warning label to this

effect appears on the cartridge.

*b. Physical Data.*

Weight of complete round with PD fuze M524 -----	9.34 lb.
Length of complete round -----	20.767 in. max.

*c. Ballistic Data.*

Charge	Maximum range (yd)
Charge 0 (ignition cartridge only) -----	300
Charges 1 (ignition cartridge plus 1 increment charge) -----	700
Charge 2 (ignition cartridge plus 2 increment charges) -----	1,300
Charge 3 (ignition cartridge plus 3 increment charges) -----	1,850
Charge 4 (ignition cartridge plus 4 increment charges) -----	2,350
Charge 5 (ignition cartridge plus 5 increment charges) (maximum increment charges au- thorized for use when firing in the Mortar M1) -----	2,700
Charge 6 (ignition cartridge plus 6 increment charges) -----	3,200
Charge 7 (ignition cartridge plus 7 increment charges) -----	3,600
Charge 8 (ignition cartridge plus 8 increment charges) -----	3,987

**25. Cartridge, 81 Millimeter: TP, M43A1, w/Fuze, PD, M52-Series, Modified**

This cartridge is for use in target-practice firing and is to be used for training purposes only. This complete round differs from that described in paragraph 27 only in the fuze which is fitted to the projectile. The modified M52 series fuze consists of a PD fuze M52A1, M52A1B1, M52A2, M52A2B1, or M52B10 that has been modified by replacing the tetryl booster charge with a black powder charge.

**26. Cartridge, 81 Millimeter: TP, M43A1, w/Fuze, PD, M525A1 or M525**

The target-practice cartridge M43A1 (fig. 12) is intended for use in target-practice firing. This cartridge is similar to the high-explosive cartridge M43A1 described in paragraph 19, except for the projectile filler. The target-practice projectile is loaded with an inert material (plaster of paris and stearic acid) and a 0.05-pound black powder pellet. The black powder pellet is loaded at the forward end of the projectile cavity adjacent to the rear end of the booster casing of the fuze. Upon impact, the black powder pellet and fuze booster charge provide a spotting charge for observation purposes. The pro-

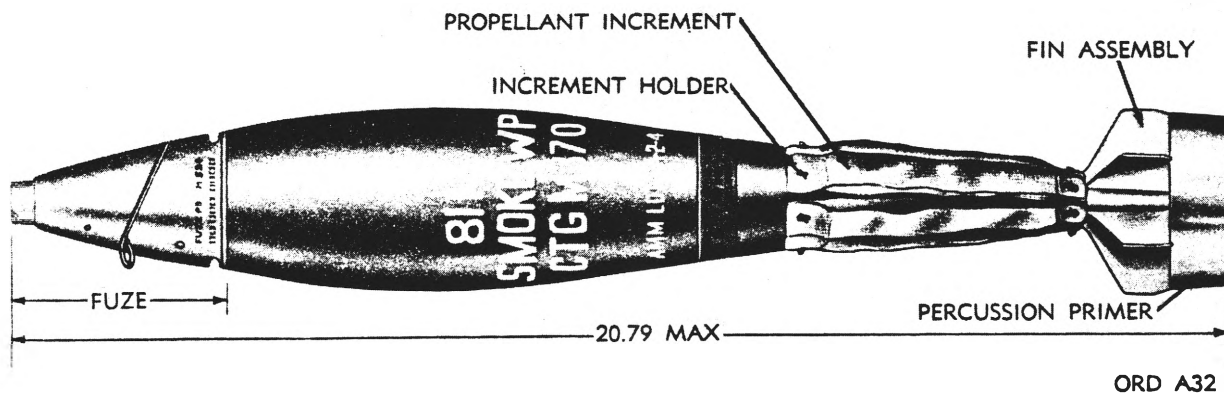

Figure 11. Cartridge, 81 millimeter: smoke, WP, M370 (T30E9), w/fuze PD, M524.

jectile is loaded to the same weight as the high-explosive projectile, thereby providing for the same ballistics. Refer to paragraph 19b and c.

### 27. Projectile, 81 Millimeter: Training, M68

a. *General.* The training projectile M68 (fig. 13) is provided for training in loading and firing the 81-mm mortars. It is completely inert and has no fuze. It consists of a cast-iron pear-shaped body, which is drilled at the narrow base for assembly of the fin assembly M6. No propellant increment charges are issued or used, except the ignition cartridge M3 or the combination of ignition cartridge M6 and percussion primer M34 for firing the training projectile. All the components are issued separately to facilitate re-

placement of wornout parts and the procurement of extra ignition cartridges. A training kit used in the field holds 10 training projectiles and accessories, including a ground hook used in recovery of fired training projectiles. Spent ignition cartridges M3 are removed by the use of a steel rod or punch with a blunt point which is driven through the hole to eject the ignition cartridge. The use of long nose pliers is the most satisfactory method for removal of the percussion primer M34 and ignition cartridge M6 after firing.

#### b. Physical Data.

Weight of complete round	-----	10.70 lb
Length of complete round	-----	11.08 in.
Weight of projectile	-----	9.8 lb
Length of projectile	-----	7.92 in.
Muzzle velocity	-----	172.8 fps
Maximum range	-----	310 yd

## Section III CARTRIDGES FOR 4.2-INCH MORTAR CANNON M30

### 28. General

a. *Weapon Description.* This mortar is a rifled-bore, muzzle-loading weapon designed for high-angle fire. In order to avoid the possibility of instability of the cartridge in flight, as far as elevation is concerned, do not fire the mortar at an elevation greater than 1.065 mils (60 degrees) with any size propelling charge.

*Note.* All of the cartridges which were authorized for the obsolete 4.2-inch mortar M2 are also authorized for 4.2-inch mortar M30. Rounds may be encountered (of

earlier manufacture) fitted with a container extension and striker nut with a warning label on the striker nut which reads: "Remove container extension and reduce propellant to not more than 25-1/2 charges (increments) before firing in 4.2-inch mortar M2." Since the obsolescence of 4.2-inch mortar M2, this warning label has no application.

b. *Identification.* Unlike 60-mm and 81-mm mortar ammunition, the 4.2-inch mortar ammunition, is stabilized in flight by rotation of the projectile rather than by fins as in the case of the 60-mm or 81-mm ammunition. The rounds appear somewhat similar to spin-stabi-

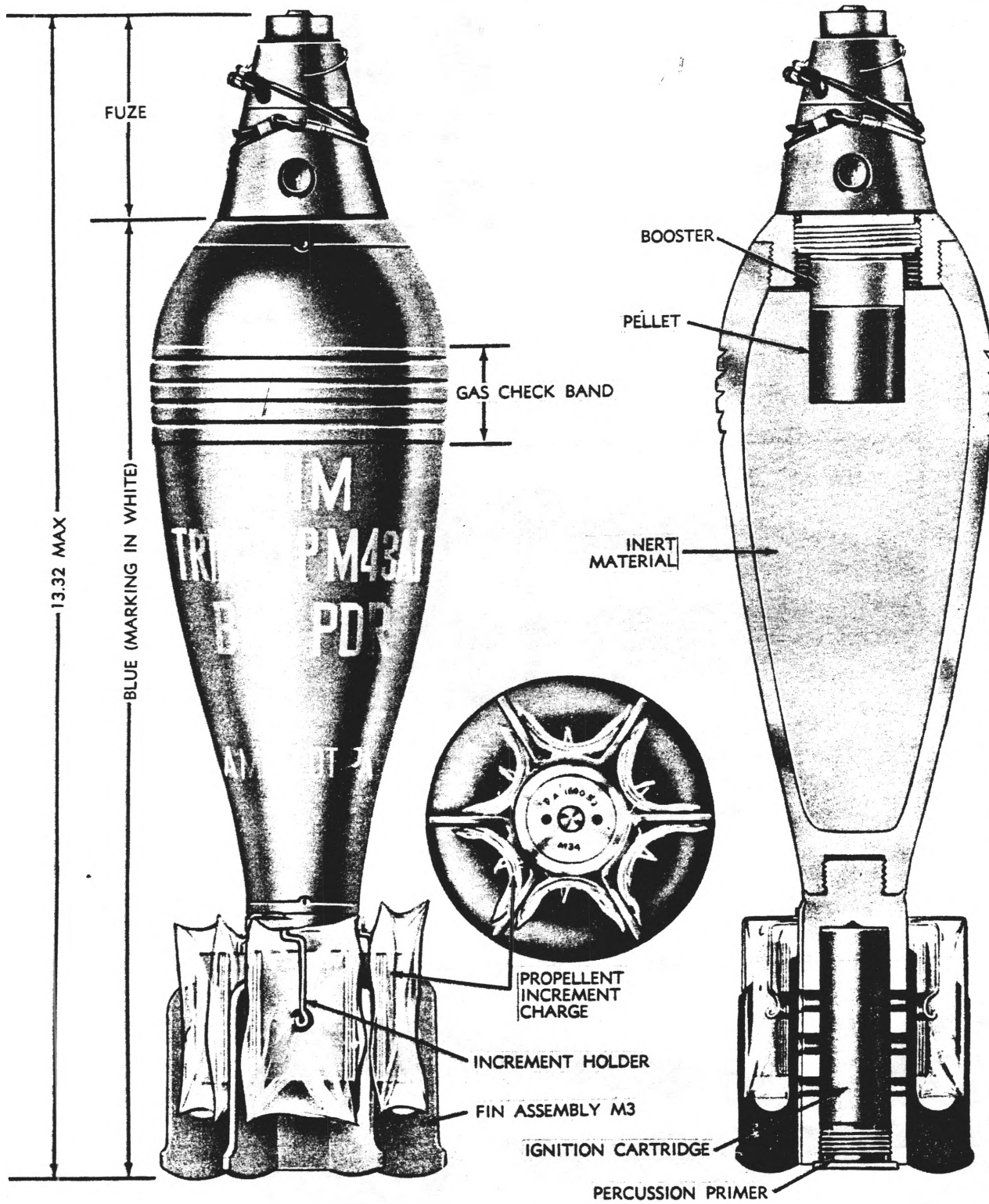

RA PD 253423A

Figure 12. Cartridge, 81 millimeter: TP, M43.1, w/fuze, PD, M525.11.



CARTRIDGE, IGNITION: M3  
OR



PRIMER,  
PERCUSSION:  
M34

A  
N  
D



CARTRIDGE,  
IGNITION:  
M6

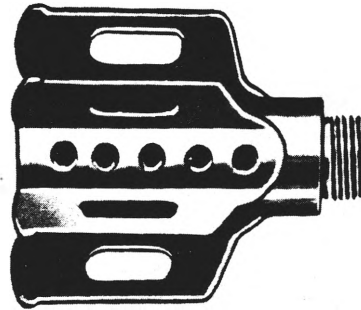

FIN ASSEMBLY,  
81 MILLIMETER: M6

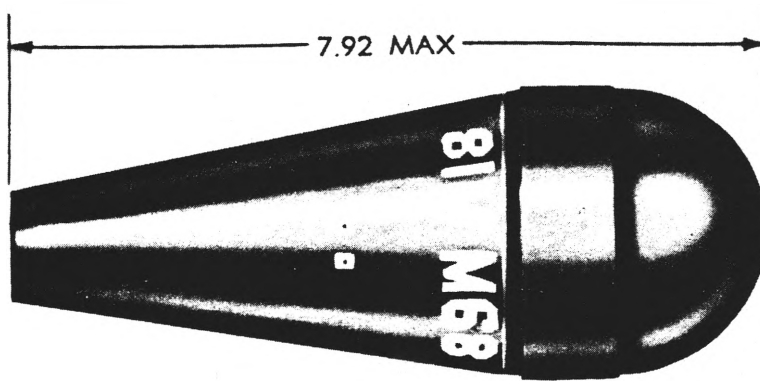

PROJECTILE, 81 MILLIMETER:  
TRAINING, M68, W/O FIN ASSEMBLY

**A—COMPONENTS**

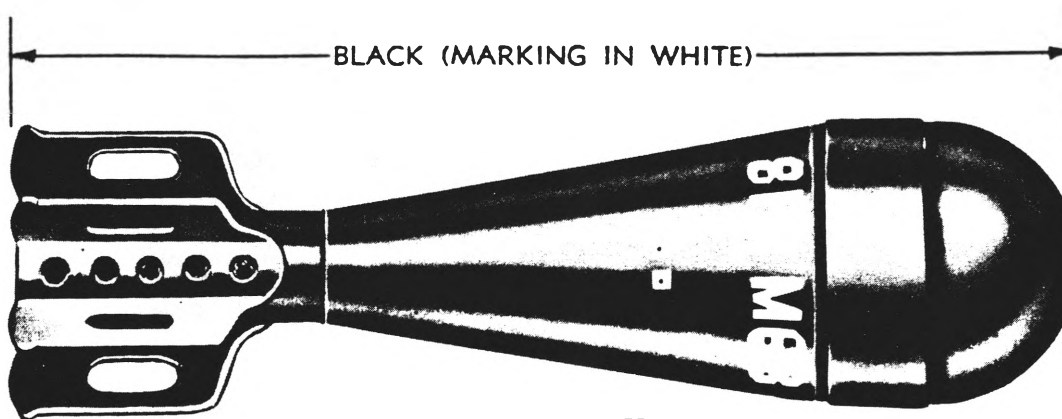

**B—ASSEMBLED**

RA PD 80777L

Figure 13. Projectile, 81 millimeter: training, M68.

lized rockets, but are distinguished by the propelling charge on the base of the cartridge. Painting and marking for identification is in accordance with the basic color scheme prescribed in TM 9-1900. See also figures 15 through 20.

*c. Projectile.* Dependent upon type of projectile, ammunition for this mortar is classified as gas (CG, H, HD, or HT), high explosive (HE), illuminating, and smoke (PWP or WP).

*d. Fuze.* Three types of point fuzes are used with 4.2-inch ammunition: impact, mechanical time and superquick, and proximity. Brief descriptions of these fuzes and rounds with which each type is used are given in (1) through (3) below. For additional information on these fuzes, refer to paragraphs 36 through 59, and fuze interchangeability chart (par. 36).

(1) *Impact-type fuze.* Point detonating fuze M8, a single-action superquick type, is used with the chemical (gas or smoke) cartridges M2 and M2A1. Point detonating fuze M9, a single-action superquick type, is used with the high-explosive cartridge M3. Point detonating fuzes M51A5 and M535 (T177E3) superquick or delay types, are used with the high-explosive cartridges M3A1 and M329. Mechanical time and superquick fuzes M500 series or M520 may also be used with cartridge M329. Point detonating fuze M521 (T247), a selective superquick or delay type, is used with the chemical (WP smoke) cartridge M328.

(2) *Mechanical-time-and-superquick type fuze.* MTSQ fuze M501A1 (or M501) is used with the illuminating cartridge M335. MTSQ fuze M500A1 (or M500) is used with high-explosive cartridges M3A1 and M329. Preparation of deep-cavity cartridges for firing with MTSQ fuzes should be in accordance with (a) through (e) below.

- (a) Place the round on its side and follow the procedure outlined in (3) (b) through (e) below.
- (b) Replace the supplementary charge

properly, with the felt pad toward base end of the projectile and the tape loop toward the nose of the projectile.

- (c) Screw in the mechanical time and superquick fuze by hand. If binding occurs, inspect the fuze cavity and threads of both fuze and projectile. Reject whichever is at fault.
  - (d) Tighten the fuze to the projectile with fuze wrench M18. Use only such force as can be applied by hand to the fuze wrench handle. If the fuze cannot be tightened to form a good seat between the projectile and fuze, reject the component at fault. *Do not hammer on the wrench or use an extension handle on it. Do not stake the fuze to the projectile under any circumstances.*
  - (e) If not fired, the fuzes and the round should be restored to their original condition and packings.
- (3) *Proximity-type fuzes.* Proximity fuzes. M513A1 (T226E2), M513B1 (T226B1, and M513 (T226) are used with the deep-cavity (supplementary charge removed) high-explosive cartridges M3A1 and M329. Preparation of deep-cavity cartridges for firing with proximity fuzes should be in accordance with (a) through (h) below.
- (a) Place the round on its side.
  - (b) Insert fuze wrench M18 (or M7A1) in the wrench slots of the fuze and strike the wrench handle sharply in a counterclockwise direction (fuse is assembled to the projectile with right-hand threads) to loosen the fuze from the projectile, taking care not to strike any part of the fuze. Unscrew and remove the fuze. If assembled with a closing plug, remove with an appropriate wrench.
  - (c) Remove the supplementary charge by means of the cloth tape loop.
  - (d) Inspect the cavity for damage. Remove any loose material from

the cavity. If any high explosive is found adhering to the threaded portion of the projectile throat, remove it with a pointed instrument made of wood or a non-ferrous metal.

- (e) Examine the projectile nose threads and the fuze threads to insure that they are in good condition. Do not use components with damaged threads.
- (f) Screw in the proximity fuze by hand. If binding occurs, inspect the fuze cavity and threads of both fuze and projectile. Reject whichever is at fault.
- (g) Tighten the fuze to the projectile with the fuze wrench M18. Use only such force as can be applied by hand to fuze wrench handle. If the fuze cannot be tightened to form a good seat between the projectile and fuze, reject the component at fault. *Do not hammer on the wrench or use an extension handle on it. Do not stake the fuze to the projectile under any circumstances.*
- (h) If not fired, the fuzes and round should be restored to their original condition and packings.

*e. Propelling Charge.* Dependent upon model of cartridge, either propelling charge M6 or propelling charge M36 is provided for 4.2-inch cartridges. The propelling charge M6, which is utilized in the cartridge M2 and M3 series, consists of 25-1/2 increments assembled in the form of 1/2 increment, four 5-increment bundles, and 5 single increments. The individual increments may be removed as required for fire adjustment (charge firing). The full propelling charge is assembled to the cartridge as issued. Maximum range is obtained with the full charge; lesser ranges, with fewer increments as required in accordance with firing tables. Chemical (gas or smoke) cartridges M2A1 differ from the M2 and M3 or M3A1 cartridges that use the propelling charge M6 in the method of securing the increments. For the cartridges M2 and M3 or M3A1, the propellant increments are secured between the striker nut and the pro-

pellant holder. The striker nut, which is on the end of the tail assembly, is large enough to hold the propellant increments in place. In contrast, the full charge for the chemical (gas or smoke) cartridges M2A1 is held firmly between the pressure plate nut and the propellant holder properly seated in its groove near the end of the ignition cartridge container. The propelling charge M36 consists of one 1/2 increment, three 5-increment bundles, 5 increments, four 5-increment bundles, and one 1/2 increment — a total of 41 increments assembled in that order. The illuminating cartridge M335, smoke cartridge M328, and the high-explosive cartridge M329 are provided with a cartridge container extension to accommodate the full propelling charge M36. The ignition cartridge is assembled in the cartridge container extension. Two propellant holders are used to secure the propellant increments. One propellant holder is seated in its groove near the center of the cartridge container extension; the other propellant holder is seated in its groove near the end of the ignition cartridge container. All propellant increments must be forward of the propellant holder which must be properly engaged in its groove in the container extension. The propellant increments should not be located over the flash holes of the container extension. When the number of increments of the propelling charge M36 is reduced to 25-1/2 increments or less, the striker nut, ignition cartridge, and cartridge container extension are removed. The ignition cartridge is inserted into the ignition cartridge container and the propelling charge is secured on the ignition cartridge container by a wire propellant holder and the striker nut in the same manner as the propelling charge M6 on the chemical cartridge M2A1. Any or all of the increments for propelling charge M6 or M36 may be removed for fire adjustment in accordance with appropriate firing tables.

*Note:* Inspection for proper assembly of propelling charges is essential in order to avoid excessive chamber pressures, erratic ranges, and short rounds. M2A1, M2A1 (alt), M328, and M329 rounds using less than seven increments may result in short rounds.

**WARNING:** Since firing of propelling charges at low temperatures results in excess pressure, the following precautions must be observed. The charges listed below will be fired **ONLY** at or above the temperatures indicated.

Charges	Temperature (°F.)
23 through 25½ increments -----	60
20 through 22½ increments -----	20
17 through 19½ increments -----	0
5 through 16½ increments -----	-40

These air temperature restrictions do not apply on firing of cartridges assembled with the cartridge container extensions.

f. *Ignition Cartridge.* The ignition cartridge used with the propelling charge M6 or M36 is designated CARTRIDGE, IGNITION: M2. It contains both primer and ignition charge. It is similar in exterior appearance to a commercial 12-gage shotgun cartridge.

g. *References.* Refer to paragraphs 60 through 63 for additional information on propelling charges; refer to paragraphs 64 through 74 for more information on ignition cartridges.

h. *Packing and Shipping Data.* The 4.2-inch mortar cartridges are packed one complete round per fiber container and two fiber con-

tainers (2 rounds) per wooden box (fig. 14). For additional information on packing of 4.2-inch mortar ammunition, refer paragraph 11 and SM 9-5-1315.

29. Cartridge, 4.2-Inch: Gas, Nonpersistent, CG, or Persistent, H, HD, or HT, M2 or M2A1, w/Fuze, PD, M8

These cartridges (fig. 15) are provided for use in the 4.2-inch mortar. They are intended for casualty effect. The rounds are similar except for the tail assemblies and for the kind of filler, and hence, slight differences in weight. They have the same projectile body, propelling charge (M6), fuze (M8), and ignition cartridge (M2). The cartridges are 4.10 inches in diameter and have a maximum overall length of 21.01 inches. Dependent upon the filler, the fuzed projectile ranges in weight from 19.86 to 21.41 pounds; the complete round ranges in weight from 23.12 to 24.67 pounds. The weight of the full pro-

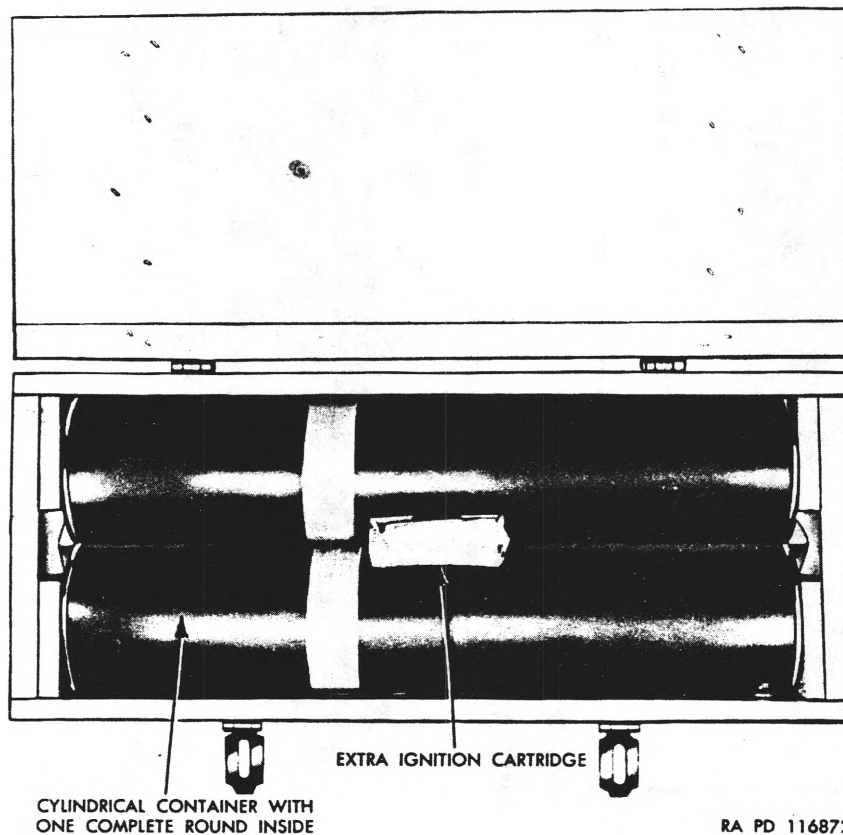
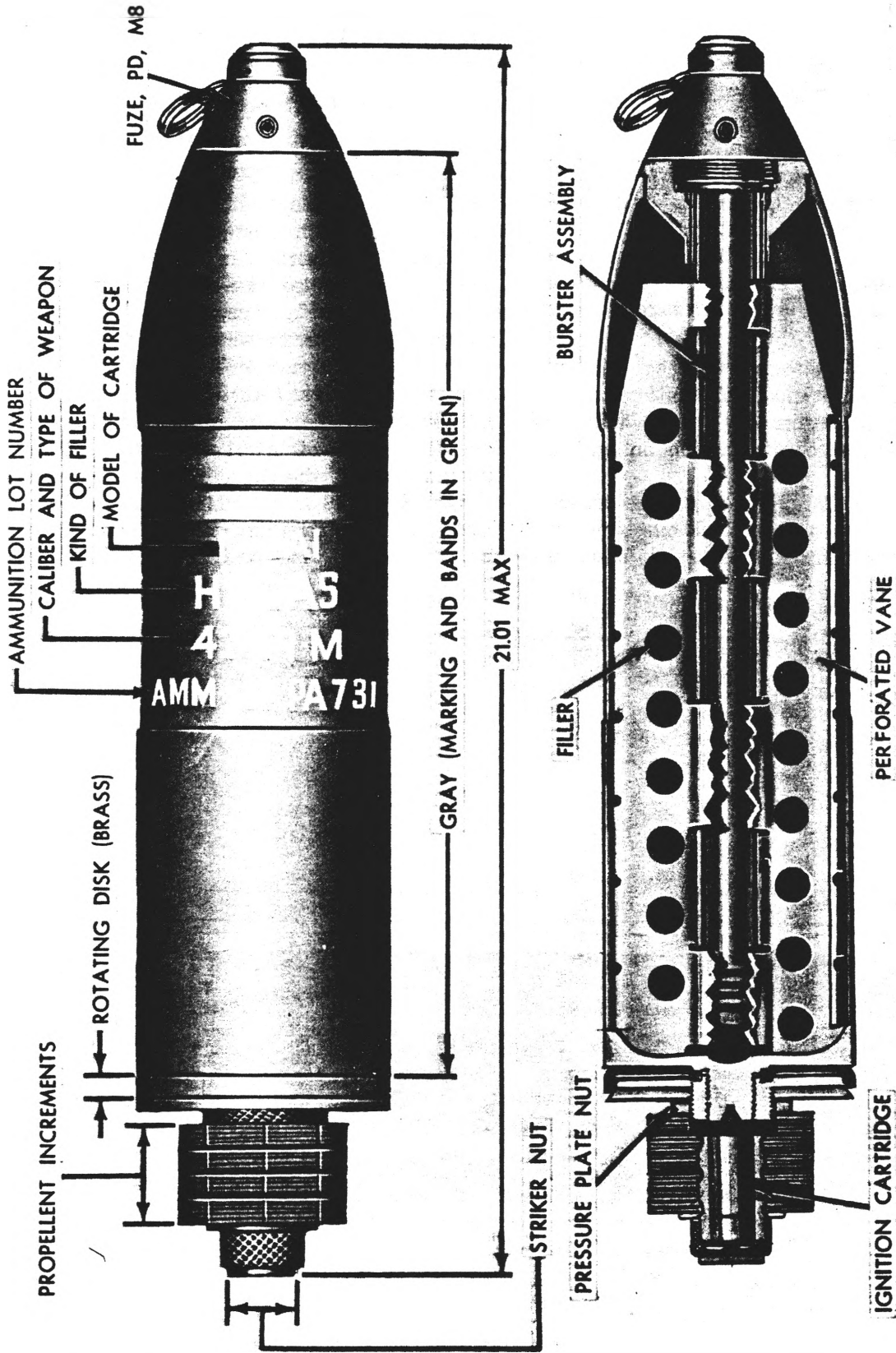

Figure 14. Fiber containers and packing box for 4.2-inch mortar ammunition.



RA PD 253424

Figure 15. Cartridge, 4.2-inch: gas, persistent, HT, M2A1, w/fuze, PD, M8.

pelling charge (25-1/2 increments) is 0.43 pound. A "rotating disk" on the base of the projectile expands on firing to engage the rifling of the mortar, thereby imparting rotation to the projectile. On the base of the projectile is an externally threaded stud to which an ignition cartridge container for holding an ignition cartridge is secured. The ignition cartridge container is a steel tube which is internally threaded on the forward end for assembly to the stud and is externally threaded on the rear end to receive a striker nut. Radial vent holes in the cartridge container are for passage of the flame from the ignition cartridge to the propellant. The propellant is held on the cartridge container by a wire "clip-type" propellant holder which is engaged in a slot near the rear end of the container. A perforated vane is welded inside the projectile. This vane aids in stabilizing flight by forcing the liquid filler to rotate the projectile. The perforations in the vane facilitate distribution of the liquid in the projectile. A burster tube attached to the PD fuze M8 extends axially into the center of the projectile. The burster acts to burst the projectile and disperse the filler. The cartridges have a maximum muzzle velocity of 879 feet per second and a maximum range of 4,961 yards. Velocities and ranges corresponding to propelling charges using different number of increments are given in appropriate firing tables.

**30. Cartridge, 4.2-Inch: HE, M3A1 (or M3A1 alt), w/Suppl Chg and Fuze, MTSQ, M500A1 (or M500), PD, M51A5, 0.05-Sec Delay, PD, M535 (T177E3) Proximity, M513A1 (T226E2), M513B1 (T226B1), or M513 (T226)**

*a. General.* This cartridge (fig. 16) is intended for fragmentation and mining effect. This cartridge is similar to the cartridge described in paragraph 29, the principal difference being that the cartridges M2 series have a perforated vane welded inside the projectile. This cartridge utilizes the propelling charge M6 and ignition cartridge M2. The striker nut is sufficiently large to hold the propellant increments in place. The projectile has a deep fuze cavity and a supplementary charge. With the supplementary charge in place in

the projectile, impact fuzes may be used. The proximity fuze M513A1 (T226E2), M513B1

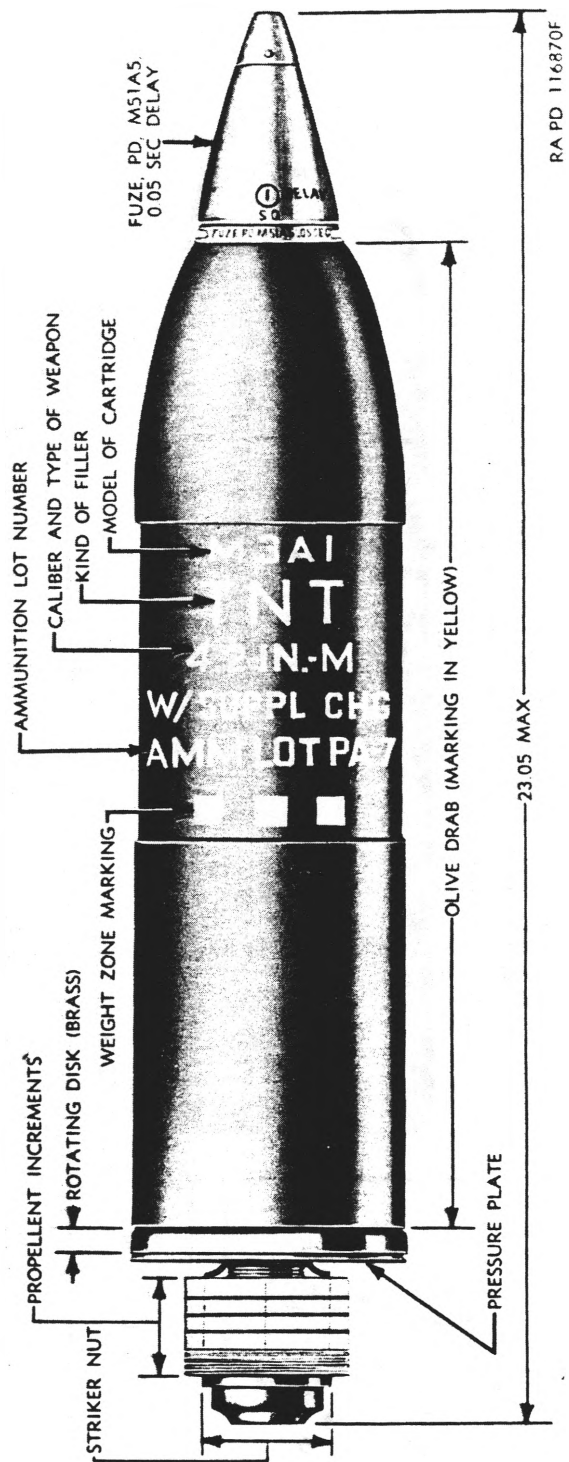

Figure 16. Cartridge, 4.2-inch: HE, M3A1, w/suppl chg and fuze, PD, M51A5, 0.05-sec delay.

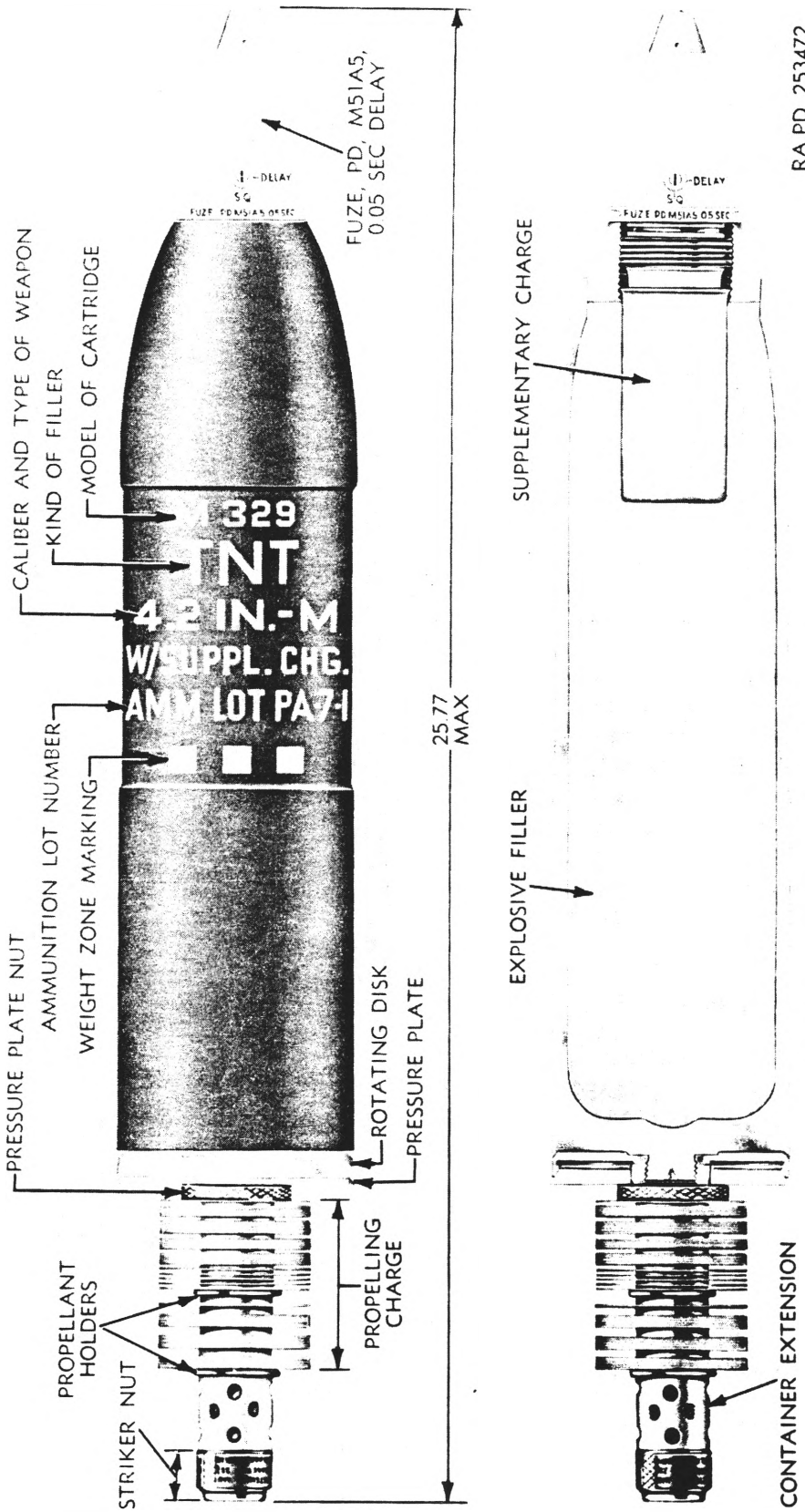

Figure 17. Cartridge, 4.2-inch: HE, M329, w/suppl chg and fuze, PD, M51A5, 0.05-sec. delay.

(T226B1), or M513 (T226) may be used when the supplementary charge is removed.

*Note.* Rounds w/ fuze M51A5 and using less than seven increments may result in duds.

*b. Data.*

Weight of complete round -----	26.95 lb
Length of complete round -----	23.05 in.
Range (max) -----	5,050 yd
Muzzle velocity (full charge) -----	845 fps
Minimum propelling charge (M3A1 (or M3A1alt)) w/ fuze VT, M513 series -----	10 increments

**31. Cartridge, 4.2-Inch: HE, M3, w/Fuze, PD, M9**

*a. General.* This cartridge is intended for fragmentation and mining effect. The cartridge M3 is similar to the cartridge M3A1 described in paragraph 30, except that it has a fuze cavity designed to accommodate the booster of fuze M9 and has slight differences in physical dimensions.

*b. Data.*

Weight of complete round -----	25.09 lb
Length of complete round -----	21 in.
Range (max) -----	5,050 yd
Muzzle velocity (max) -----	845 fps

**32. Cartridge, 4.2-Inch: HE, M329, w/Suppl Chg and Fuze, MTSQ, M500A1 (or M500), PD, M51A5, 0.05-Sec. Delay, PD, T177E3, Proximity, M513A1 (T226-E2), M513B1 (T226B1), or M513 (T226), or w/Suppl Chg, w/o Fuze**

*a. General.* This cartridge (fig. 17) is intended for fragmentation and mining effect. The projectile contains a deep fuze cavity and supplementary charge of TNT, thereby either impact or proximity fuzes may be assembled to it. This cartridge can be distinguished from the cartridges M2 series and M3 series by the extended length (cartridge container extension) of its cartridge container and its 41-increment propelling charge M36. The cartridge M329 is similar to the cartridges M3 series except for the tail assembly. The principal parts of the tail assembly for this cartridge are the cartridge container, cartridge container extension, pressure plate, pressure plate nut, rotating disk, propellant holders, and striker nut assembly. The cartridge container extension is required in order to provide space for the propellant increments of the full propelling charge M36. The projectile for this cartridge has a steel body with sil-

ver-brazed adapters at both ends. The nose adapter, with a 2-inch internal thread, has been designed to accommodate impact, delay, or proximity fuzes. To provide a means for attaching the tail assembly to the projectile body, a stud with an external thread is provided on the base adapter. An alternate design of the cartridge M329, the M329B1 may have a projectile body made from a forging with an integral base and the nose adapter silver-brazed to the body.

*b. Data.*

Weight of complete round -----	27.07 lb
Length of complete round -----	25.77 in.
Range (max) -----	5,931 yd
Muzzle velocity (max) -----	960 fps
Minimum propelling charge (M329 round w/ fuze, VT, M513 series) -----	10 increments

**33. Cartridge, 4.2-Inch: Illuminating, M335, w/Fuze, MTSQ, M501A1 (or M501)**

*a. General.* This cartridge (fig. 18) is intended for use in night missions requiring illumination for purposes of observation. The projectile consists of five major components: illuminating canister assembly, parachute assembly, expelling charge assembly, parachute holder assembly, and a mechanical time and superquick fuze. The tail assembly for the illuminating cartridge M335 is the same as the tail assembly for the high-explosive cartridge M329 described in paragraph 32, and thus utilizes the propelling charge M36. The projectile body for the illuminating cartridge differs from the other projectile bodies for the 4.2-inch mortar by the detachable base plate which is press fitted into position and is secured by four equally spaced copper shear pins. In order for this projectile to function, the fuze must ignite the black powder in the expelling charge assembly, which is adjacent to the fuze. The pressure from the gases produced by the burning of the black powder charge is sufficient to eject the base plate from the bottom of the projectile. The various assemblies inside the projectile are expelled next from the base of the projectile by the gas pressure. As the black powder in the expelling charge burns progressively, it not only produces sufficient pressure to shear the copper pins securing the base plate, but it produces flames which travel through the holes in the baffle plate, baffle gasket, and base of

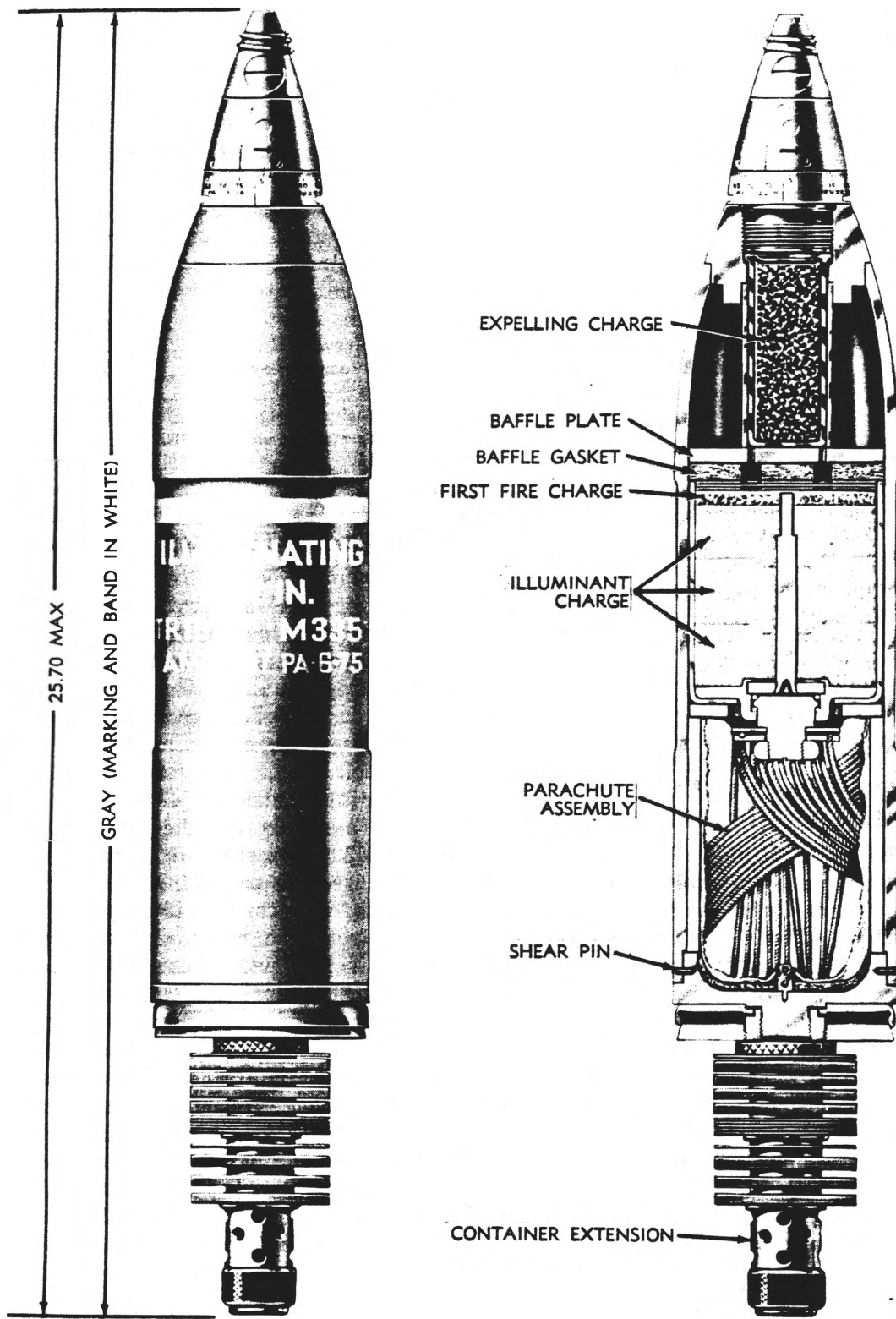

RA PD 253473A

Figure 18. Cartridge, 4.2-inch: illuminating, M335, w/fuze, MTSQ, M051A1.

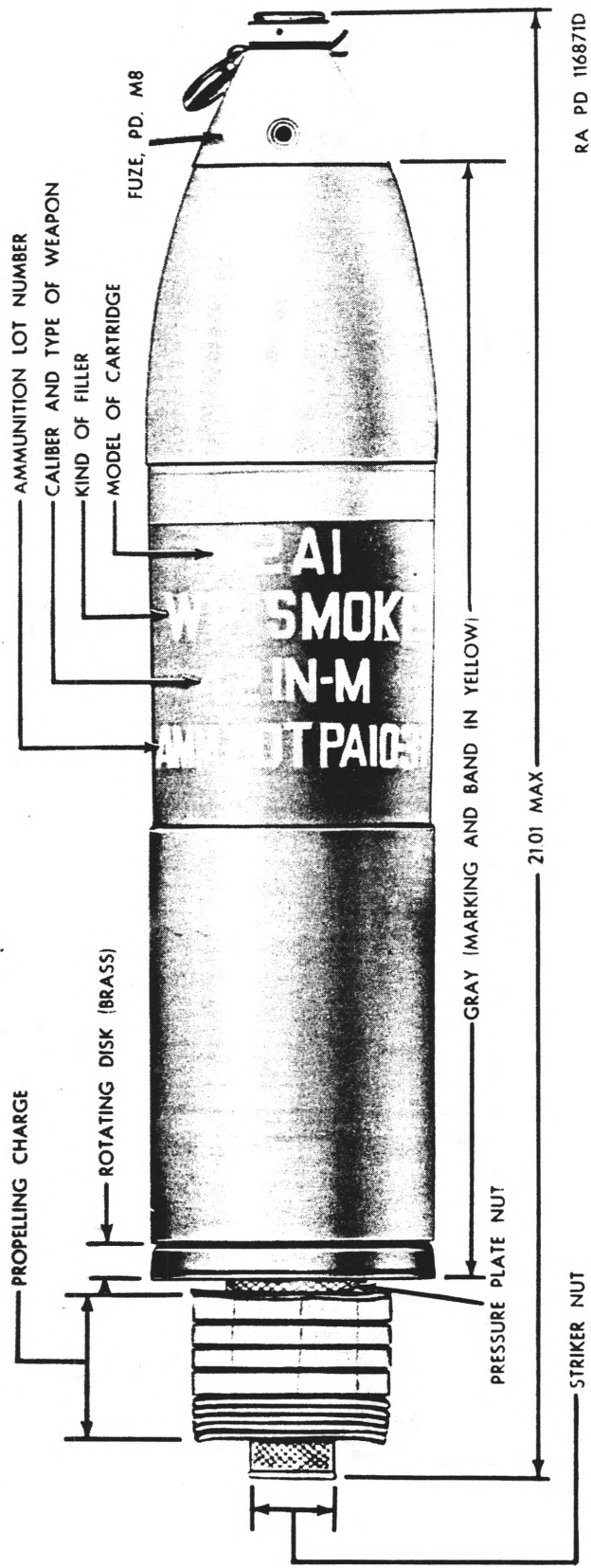

RA PD 116871D

Figure 19. Cartridge, 4.2-inch: smoke, WP, M2A1, w/fuze, PD, MS.

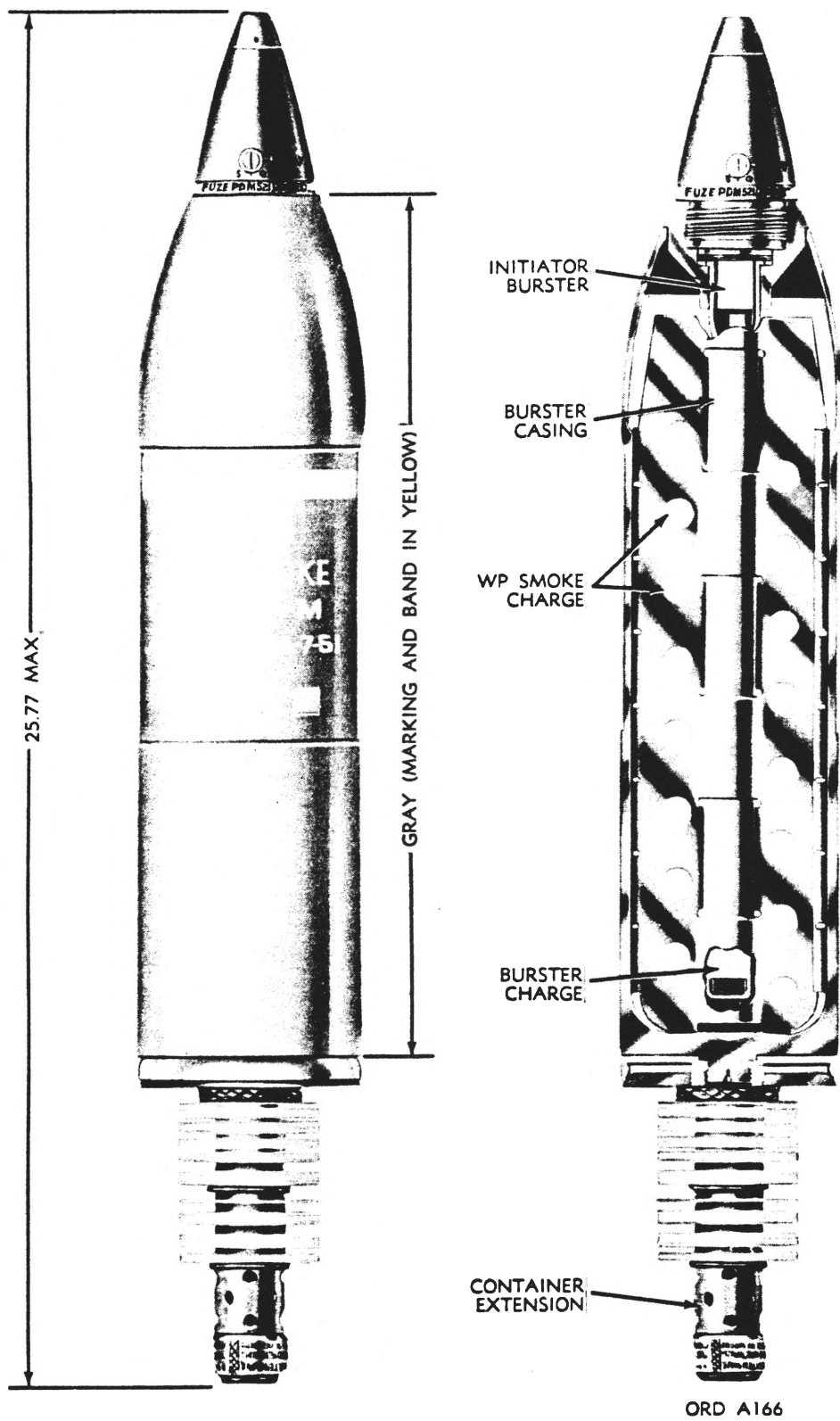

Figure 20. Cartridge, 4.2-inch: smoke, WP, M328, w/fuze, PD, M521 (T247).

the illuminating canister assembly" to ignite the first-fire charge. The first-fire charge in turn, ignites the illuminant charge which produces a luminosity of 500,000 candlepower. The illuminant has a static burning time of 70 seconds. A parachute opens permitting the illuminant to illuminate the surrounding terrain immediately upon clearance of the various assemblies from the projectile body.

*b. Data.*

Weight of complete round	-----	26	lb (approx)
Length of complete round	-----	25.696	in. (max)
Range (max)	-----	5,272	yd
Muzzle velocity (max)	-----	931	fps

**34. Cartridge, 4.2-Inch: Smoke, PWP, or WP, M2 or M2A1, w/Fuze, PD, M8**

These cartridges (fig. 19) are provided for use in the 4.2-inch mortar. They are intended for screening, incendiary, or casualty producing purposes. The rounds are similar except for the tail assemblies and for the kind of filler, and hence, slight differences in weight. They have the same projectile body, propelling charge (M6), fuze (M8), and ignition cartridge (M2). The cartridges are 4.19 inches in diameter and have a maximum overall length of 21.01 inches. Dependent upon the filler, the complete round ranges in weight from 23.74 to 24.91 pounds. The weight of the full propelling charge (25-1/2 increments) is 0.43 pound. A "rotating disk" on the base of the projectile expands upon firing to engage the rifling of the mortar, thereby imparting rotation to the projectile. On the base of the projectile is an externally threaded stud to which an ignition cartridge container for holding an ignition cartridge is secured. The ignition cartridge container is a steel tube which is internally threaded on the forward and for assembly to the stud and is externally threaded on the rear end to receive a striker

nut. Radial vent holes in the cartridge container are for passage of the flame from the ignition cartridge to the propellant. The propellant is held on the cartridge container by a wire "clip-type" propellant holder which is engaged in a slot near the rear end of the container. A perforated vane is welded inside the projectile. This vane aids in stabilizing flight by forcing the filler to rotate the projectile. The perforations in the vane facilitate distribution of the filler in the projectile. A burster tube attached to the PD fuze M8 extends down into the center of the projectile. This burster acts to burst the projectile and disperse the filler. The cartridges have a maximum muzzle velocity of 845 feet per second and maximum range of 5,050 yards. Velocities and ranges corresponding to propelling charges using difference numbers of increments are given in appropriate firing tables.

**35. Cartridge, 4.2-Inch: Smoke, WP, M328, w/Fuze, PD, M521 (T247)**

*a. General.* This cartridge (fig. 20) is intended for producing a smoke screen, although it may also have an incendiary effect. The cartridge is similar to the smoke cartridges described in paragraph 34 differing in the tail assembly which is similar to the tail assembly (with container extension) used in the high-explosive cartridge M329 and the illuminating cartridge M335. Therefore, this cartridge utilizes the propelling charge M36. The projectile contains a burster assembly which is actuated by the functioning of the fuze.

*b. Data.*

Weight of complete round	-----	28.66	lb
Length of complete round	-----	25.77	in.
Range (max)	-----	5,931	yd
Muzzle velocity (max)	-----	960	fps





Small illegible marks on the left margin.

Small illegible marks on the left margin.

Faint, illegible text or markings in the center of the page.

the explosive train is so interrupted that, while the projectile is still in the bore of the weapon, premature action of the bursting charge is prevented should any of the more sensitive elements (primer or detonator) function. The fuzes used with the ammunition described herein are considered boresafe.

**CAUTION: Fuzes will not be disassembled (taken apart). Any attempt to disassemble fuzes in the field is dangerous and is prohibited except under specific directions from the Chief of Ordnance.**

*c. Special Precautions Pertaining to M525, M526, and M525-Series Fuzes.*

- (1) Cartridges will not be lifted or handled by the cord which is attached to the pull wire and the safety wire.
- (2) The pull wire and the safety wire will be withdrawn from the fuze just before firing and at no other time.
- (3) Be certain that the bore-riding pin is in place in the fuze when the cartridge is loaded into the mortar.

*f. Methods of Arming.* A fuze is said to be armed when it is ready to detonate the projectile, that is, when all parts are in, or are free to move to, their proper positions so that the fuze may operate in its intended manner. The principal forces used in arming fuzes are *inertia* and *centrifugal*. In some fuzes, both these forces are used to actuate safety devices; in others, only one is used.

- (1) *Inertia* may be exhibited in several ways, each of which may be used to advantage, or each of which must be guarded against.
  - (a) "Setback" is a manifestation of inertia which occurs when the projectile accelerates on being fired. It may be used to unlock safety devices, or lock them in place until the proper time for unlocking.
  - (b) "Creep" is a manifestation of inertia which occurs as the projectile body decelerates in flight. Fuzes are designed to prevent this phenomenon from causing a malfunction.
  - (c) "Setforward" is a manifestation of inertia which occurs at impact or sudden deceleration. This effect may be used to drive firing pins

into primers or to drive primers against stationary firing pins.

- (2) *Centrifugal force* occurs in spinning projectiles, hence it is not present in fin-stabilized projectiles. This force may be utilized to actuate gear trains, and to move safety devices into their proper positions in fuzes and boosters. Such fuzes and boosters are designed to operate in the rotational velocity range of the cartridge-weapon combination in which they are used. Rotational speed is dependent upon the twist of the rifling and the muzzle velocity. Fuzes utilizing centrifugal force also must be designed so that they will not become unarmed as the rotational velocity decreases during flight.

*g. Detonators.*

- (1) *General.* A detonator (fig. 21) is used in the explosive train to create or transmit a detonation wave to the booster charge, booster lead, or burster. Two types of detonators are employed in fuzes for mortar ammunition. One contains a primer mixture as the upper layer, for initiation by stab action of a firing pin. Another contains lead azide as the upper layer, for initiation either by flame action from a separate primer, delay pellet, time train ring, or by detonation of a separate detonator. Most detonator cups and disks are made of aluminum. Table II lists the various detonators used in fuzes and boosters for mortar ammunition, indicating their use, dimensions, and color identification.
- (2) *Identification.* Colors are used to distinguish between the insensitive and sensitive ends of detonators. Yellow is used on detonators which do not contain primer mixture or igniting mixture; green, on detonators containing primer mixture; and black, on detonators having a heavy disk (0.02 inch instead of 0.002 inch) on the primer mixture end. Detonators usually are not colored ex-



1. Policy

2. Strategy

3. Tactics

4. Operations

5. Logistics

6. Intelligence

7. Communications

8. Training

9. Maintenance

10. Security

11. Personnel

12. Equipment

13. Supplies

14. Transport

15. Medical

16. Legal

17. Public

18. Media

19. Finance

20. Administration

21. Planning

22. Evaluation

23. Reporting

24. Coordination

25. Collaboration

26. Partnership

27. Alliance

28. Coalition

29. Network

30. Community

31. Stakeholder

32. Interest

33. Group

34. Organization

35. Institution

36. System

37. Structure

38. Framework

39. Model

40. Theory

41. Practice

42. Experience

43. Knowledge

44. Skill

45. Ability

46. Competence

47. Expertise

48. Proficiency

49. Mastery

50. Excellence

1. *Methods of*  
 2. *the*  
 3. *the*  
 4. *the*  
 5. *the*  
 6. *the*  
 7. *the*  
 8. *the*  
 9. *the*  
 10. *the*  
 11. *the*  
 12. *the*  
 13. *the*  
 14. *the*  
 15. *the*  
 16. *the*  
 17. *the*  
 18. *the*  
 19. *the*  
 20. *the*  
 21. *the*  
 22. *the*  
 23. *the*  
 24. *the*  
 25. *the*  
 26. *the*  
 27. *the*  
 28. *the*  
 29. *the*  
 30. *the*  
 31. *the*  
 32. *the*  
 33. *the*  
 34. *the*  
 35. *the*  
 36. *the*  
 37. *the*  
 38. *the*  
 39. *the*  
 40. *the*  
 41. *the*  
 42. *the*  
 43. *the*  
 44. *the*  
 45. *the*  
 46. *the*  
 47. *the*  
 48. *the*  
 49. *the*  
 50. *the*  
 51. *the*  
 52. *the*  
 53. *the*  
 54. *the*  
 55. *the*  
 56. *the*  
 57. *the*  
 58. *the*  
 59. *the*  
 60. *the*  
 61. *the*  
 62. *the*  
 63. *the*  
 64. *the*  
 65. *the*  
 66. *the*  
 67. *the*  
 68. *the*  
 69. *the*  
 70. *the*  
 71. *the*  
 72. *the*  
 73. *the*  
 74. *the*  
 75. *the*  
 76. *the*  
 77. *the*  
 78. *the*  
 79. *the*  
 80. *the*  
 81. *the*  
 82. *the*  
 83. *the*  
 84. *the*  
 85. *the*  
 86. *the*  
 87. *the*  
 88. *the*  
 89. *the*  
 90. *the*  
 91. *the*  
 92. *the*  
 93. *the*  
 94. *the*  
 95. *the*  
 96. *the*  
 97. *the*  
 98. *the*  
 99. *the*  
 100. *the*

1. *the*  
 2. *the*  
 3. *the*  
 4. *the*  
 5. *the*  
 6. *the*  
 7. *the*  
 8. *the*  
 9. *the*  
 10. *the*  
 11. *the*  
 12. *the*  
 13. *the*  
 14. *the*  
 15. *the*  
 16. *the*  
 17. *the*  
 18. *the*  
 19. *the*  
 20. *the*  
 21. *the*  
 22. *the*  
 23. *the*  
 24. *the*  
 25. *the*  
 26. *the*  
 27. *the*  
 28. *the*  
 29. *the*  
 30. *the*  
 31. *the*  
 32. *the*  
 33. *the*  
 34. *the*  
 35. *the*  
 36. *the*  
 37. *the*  
 38. *the*  
 39. *the*  
 40. *the*  
 41. *the*  
 42. *the*  
 43. *the*  
 44. *the*  
 45. *the*  
 46. *the*  
 47. *the*  
 48. *the*  
 49. *the*  
 50. *the*  
 51. *the*  
 52. *the*  
 53. *the*  
 54. *the*  
 55. *the*  
 56. *the*  
 57. *the*  
 58. *the*  
 59. *the*  
 60. *the*  
 61. *the*  
 62. *the*  
 63. *the*  
 64. *the*  
 65. *the*  
 66. *the*  
 67. *the*  
 68. *the*  
 69. *the*  
 70. *the*  
 71. *the*  
 72. *the*  
 73. *the*  
 74. *the*  
 75. *the*  
 76. *the*  
 77. *the*  
 78. *the*  
 79. *the*  
 80. *the*  
 81. *the*  
 82. *the*  
 83. *the*  
 84. *the*  
 85. *the*  
 86. *the*  
 87. *the*  
 88. *the*  
 89. *the*  
 90. *the*  
 91. *the*  
 92. *the*  
 93. *the*  
 94. *the*  
 95. *the*  
 96. *the*  
 97. *the*  
 98. *the*  
 99. *the*  
 100. *the*

THE END

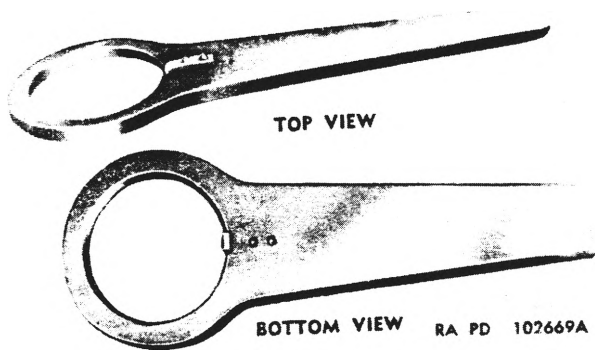

Figure 22. Fuze setter M14.

(2) *Fuze wrenches.*

(a) Some mortar cartridges are

PD	MTSQ	TSQ	Proximity	Closing plugs for cartridge of calibers
M51 series	M500 series	M77	M513 series	81 millimeter
M521	M501A1 (or M501)		M517 (T178E3)	4.2-inch
M524	M501 series			
M535	M520			

The screwdriver end of fuze wrench M18 is used for the selective setting sleeve in the fuzes M51A5, M535 (T177E3), and M521 (T247).

*j. Packing and Shipping.* Packing and shipping data for separately issued fuzes appear in SM 9-5-1390.

37. *Fuze, Mechanical Time and Superquick: M500A1 (or M500)*

*a. General.* This fuze (fig. 24) is a combination mechanical time and superquick fuze with settings for time action (2 to 75 seconds) and an impact element for superquick action. The time action of this fuze is based on a clockwork principle. A safety disk prevents functioning of the fuze at less than 1.5 seconds time of flight. A minimum calibration setting of 2 seconds is provided. The fuze is graduated in 1/2-second intervals up to 75 seconds. A pull wire extends through the fuze body and under the setback pin, providing positive safety during shipment and handling. The fuze is set safe as shipped. The

shipped unfuzed but with closing plugs assembled thereto; they are fuzed in the field. Also, due to tactical requirements, fuzes fitted to cartridges as issued, may necessitate changing a fuze to another type of fuze. Replacement or renovation activities require the use of fuze wrenches. Fuze wrenches are required for fitting fuzes or closing plugs to and removing fuzes from projectiles.

(b) Fuze wrench M18 (fig. 23), is a "box-type" wrench having two throat openings, the opening at the proximity end being 2.16 inches and the opening at the other end being 2.04 inches. This wrench is used with the following fuzes and closing plugs:

fuze M500, an earlier model of this fuze, differs in the time setting (3 to 75 seconds) and in the minimum calibration setting (3 seconds). The fuze M500A1 consists of five components as described in (1) through (5) below:

- (1) *Movement assembly.* The movement assembly provides for the mechanical time action of the fuze. It consists of a firing pin and timing mechanism (clockwork).
- (2) *Body.* The aluminum body contains the explosive elements consisting of a primer and a relay and has the time setting ring. It is externally threaded to engage the booster M21A4.
- (3) *Booster M21A4.* The forward end of this booster screws over the rearward end of the fuze body. The booster is threaded externally to engage the nose threads of the projectile.
- (4) *Lower cap.* The brass lower cap

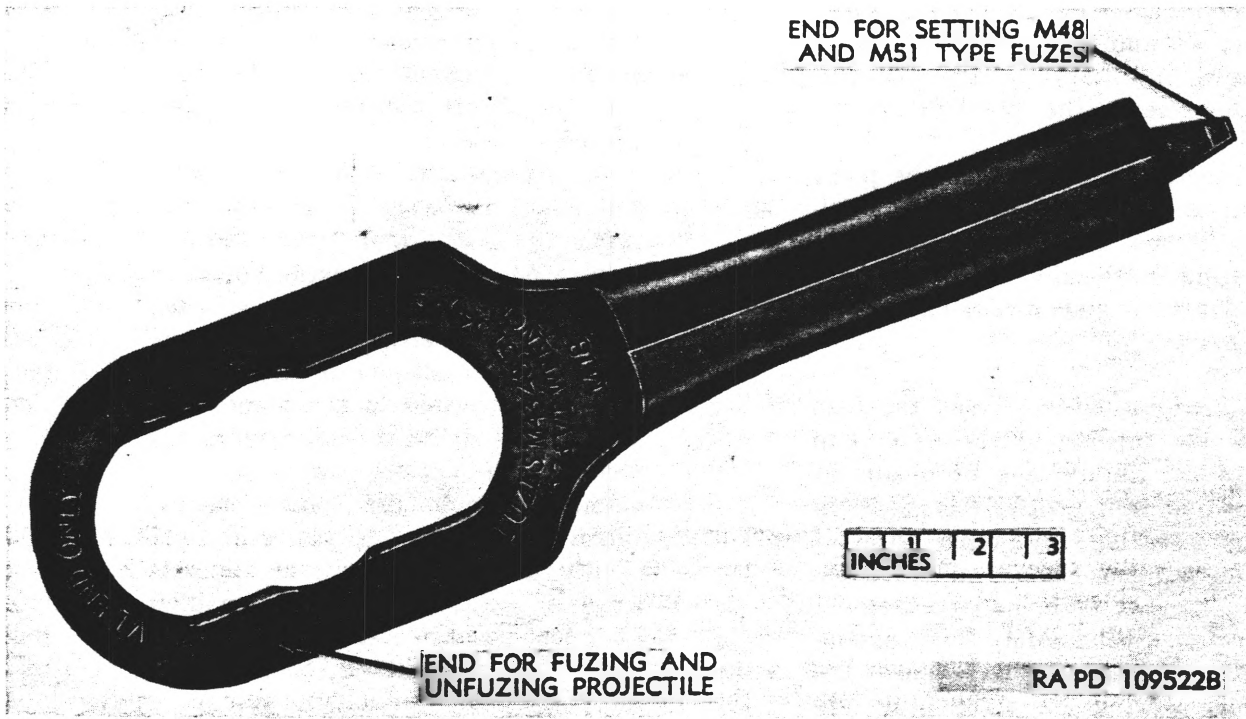

Figure 23. Fuze wrench M18.

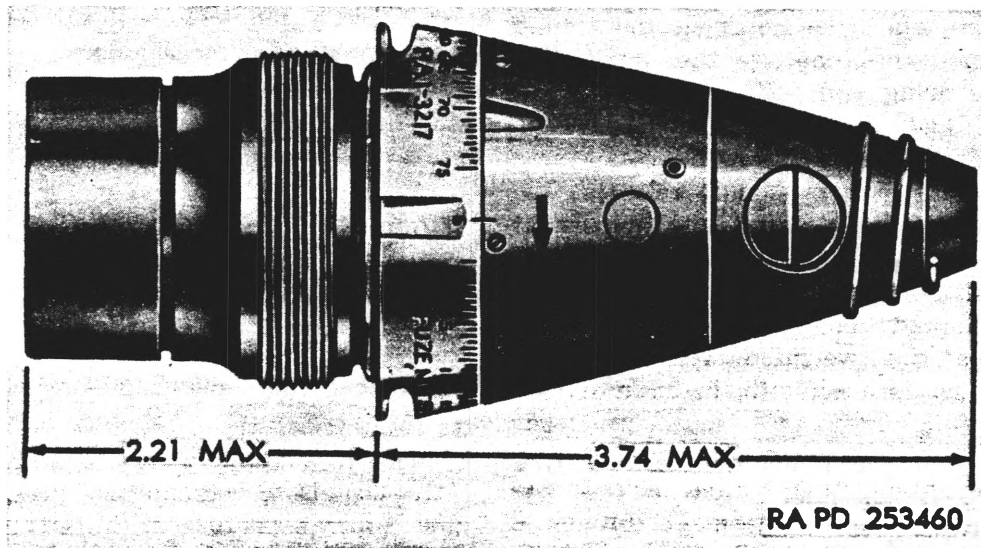

Figure 24. Fuze, mechanical time and superquick: M500.A1.

houses the major portion of the movement assembly and contains the setting pin and hammer spring. It is threaded internally at the forward end to receive the point detonator assembly.

- (5) *Point detonator assembly.* The point detonator assembly houses the superquick impact element of the fuze, consisting essentially of a firing pin and support, and a detonator and lead charge.

*b. Functioning.*

- (1) *Movement assembly.* When the fuze is set, the turning of the lower cap rotates the timing disk by means of the setting pin, which is engaged in the upraised lug. All other parts of the mechanism remain in position, since the gear train and escapement are locked by the safety lever assembly. Upon firing, setback causes the hammer spring to strike the upraised lug on the timing disk, flattening the lug and releasing the disk from the setting pin. The hammer returns to its original position as setback ceases. Setback also moves the setback pin toward the base of the fuze, leaving the firing arm free to turn when the notch in the timing disk comes opposite the upright on the firing arm. When sufficient centrifugal force has developed, the safety lever holding the escapement moves outward and releases the escapement, leaving the movement free to run. Simultaneously, centrifugal force augmented by backlash and the "kickoff" springs actuates the weighted gear segments which, in mesh with the main driving pinion, drive the movement. The rate of rotation of the pinion and, therefore, of the timing disk is governed by the escapement through a series of gears. When the notch in the timing disk reaches the upright of the firing arm, the firing arm turns, permitting the firing pin safety plate to swing out from under the firing pin flange. The firing pin

then strikes the primer under the action of the spring. This initiates the action of the explosive train, which action is transmitted to the fuze booster and the projectile bursting charge.

- (2) *Point detonator assembly.* The point detonator assembly functions independently of the movement assembly to provide superquick action; that is, it will function if impact occurs before the time setting or if the time is set at "S" (safe) on impact. Bore-safety is provided in the point detonator assembly by a slider which interrupts the passage between the detonator and the lead charge. When the projectile is spinning sufficiently fast, the slider is moved outward by centrifugal force providing an open passage between the detonator and lead charge, thus arming the point detonator assembly.

*c. Data.*

Length:		
Visible	-----	3.74 in.
Overall	-----	5.95 in.
Weight	-----	2.14 lb

*Note.* PD fuze M500 is being renovated by replacing booster M21A4 with booster M125 after renovation the fuze will be known as FUZE, PD: M520 (par. 40).

*d. Preparation for Firing.*

- (1) Remove the pull wire.  
 (2) Set the fuze to the desired time using the fuze setter M14, M23, M26, or M27.

*Note.* If, after the fuze is set preparatory to firing, the round is not fired, the fuze will be reset to the safe position ("S") and the pull wire replaced in its proper position before returning the cartridge to its packing.

**38. Fuze, Mechanical Time and Superquick: M501A1 (or M501)**

*a. General.* The fuze M501A1 (or M501) (fig. 25) is a combination mechanical time and superquick fuze with settings for time action (2 to 75 seconds) and an impact element for superquick action. This fuze is similar to the fuze M500A1 (or M500) described in paragraph 37, except that it does not have a booster. The threaded fuze base is assembled directly into the projectile.

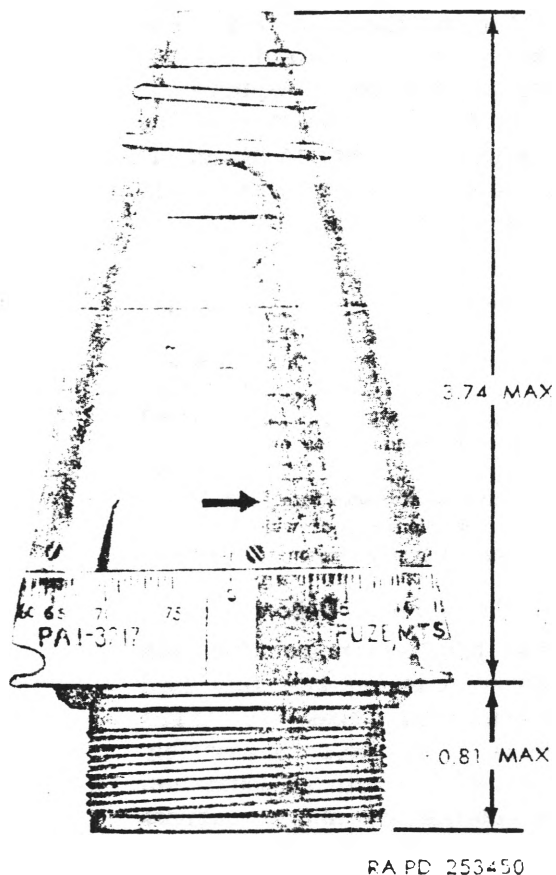

25. Fuze, mechanical time and superquick; M501.11.

*b. Data.*

Length:		
Visible	-----	3.74 in.
Overall	-----	4.55 in.
Weight	-----	1.41 lb.

*c. Preparation for Firing.* The fuze is set in the same manner as the fuze M500A1 (or M500) described in paragraph 37.

**39. Fuze, Mechanical Time and Superquick: M520**

*a. General.* This fuze (fig. 26) is a dual-purpose fuze which may be used as an alternative to point detonating fuze M51A5 in 4.2-inch high-explosive cartridge M329 or M329B1. It has a 75-second timing mechanism, a point detonator with superquick impact action, and a booster which has a delay arming clockwork mechanism for additional safety.

*b. Description.* The fuze consists of movement assembly, point detonator assembly, lower cap, body, and booster M125.

- (1) The movement assembly contains a clockwork mechanism which utilizes centrifugal force acting on two gear segment weights. Springs assist in overcoming inertia of the weights thereby insuring functioning of the fuze at relatively low as well as the higher rates of projectile spin.
- (2) The point detonator assembly which houses a superquick impact element, consists of the nose and the head of the fuze. The nose contains a point detonator firing pin and a support cup. The head contains an interrupter, detonator M22, and lead charge.
- (3) The lower cap (brass) contains provision for setting and releasing a timing disk of the arming mechanism. A setting slot on the exterior of the lower cap provides for fuze setting.
- (4) The aluminum body houses a percussion primer (M29A1) and a relay (M7). It has 0.5-second graduation up to 75 seconds. A safety line with the letter "S" in the setting slot indicates a point in setting at which the timing mechanism cannot function. The fuze is set "Safe" when shipped, that is, with the "S" registering with the indicator line on the lower cap. The setting slot is for fuze setting and the slots on the side of the body are for a fuze wrench when fitting the fuze to a projectile.

*c. Functioning.* The fuze, either if shipped separately or attached to the projectile of a cartridge, is in its unarmed condition. When the fuze is set, the turning of the lower cap rotates a timing disk in the internal timing clockwork mechanism. Upon firing, setback and centrifugal force cause the mechanism to move to a position such that the fuze will function when the number of seconds at which the fuze is set have elapsed.

*d. Booster M125.* This booster is a spin-actuated delay arming type for use in conjunction with time and impact-type point

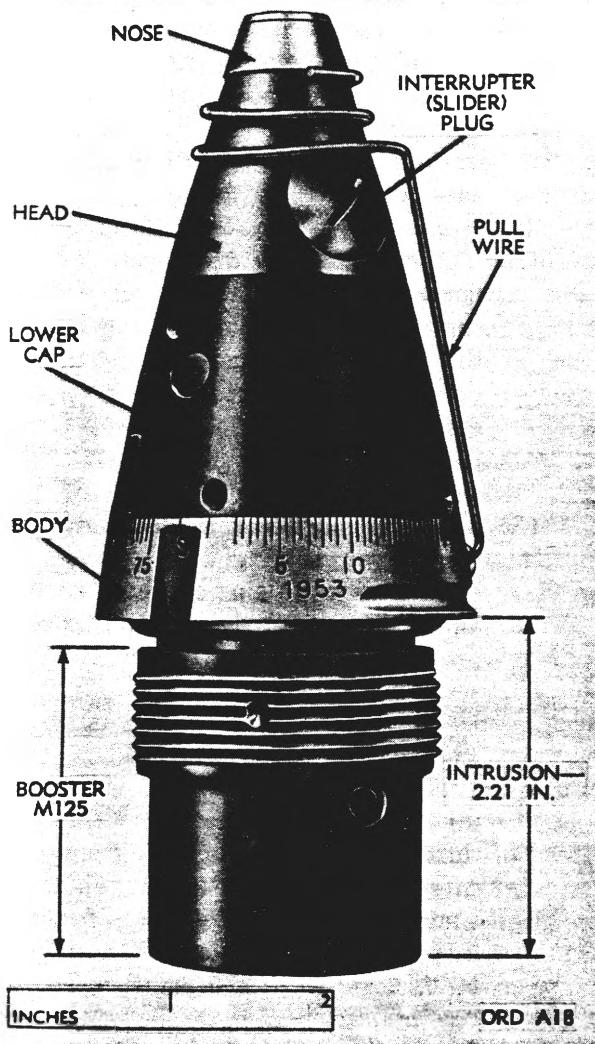

Figure 26. Fuze, mechanical time and superquick: M520.

fuzes. It consists of a threaded brass body and contains rotor which has a flash initiated detonator, and a clockwork delay arming mechanism. Its function is to provide additional safety to time and impact-type fuzes through use of a centrifugally operated out-of-line rotor interrupter and a clockwork delay arming mechanism, which delays arming until the projectile is at a safe distance from the muzzle of the weapon.

*e. Preparation for Firing.*

- (1) Remove the pull wire before setting the fuze.

- (2) By means of a fuze setter or hand setting wrench (par. 36), set the fuze by turning the lower cap *counterclockwise* to the desired setting. No other preparation is required.

*f. Precautions in Use.* Do not remove the pull wire until immediately prior to firing. If the pull wire has been removed and the round is not fired, replace the pull wire.

*g. Data.*

Length (including booster) -----	5.95 in.
Intrusion (including booster) -----	2.21 in.
Weight (including booster) -----	2.06 lb
Thread size (fuze) -----	1.7-14NS-1
Thread size (booster) -----	2-12NS-1
Minimum functioning time of timing mechanism -----	1.5 sec
Lowest setting at which fuze will function ---	2.0 sec
Lowest revolution rate at which turning mechanism or point detonator will arm ----	2,000 rpm

**40. Fuze, Point Detonating: M8**

*a. General.* The point detonating fuze M8 (fig. 27) is a superquick impact-type fuze used with 4.2-inch chemical cartridges. It weighs about 1-1/2 pounds. The complete assembly consists of the fuze proper with an aluminum body, its various components, and a seamless steel burster tube. The bursting charge consists of about 65 grams of tetryl pellets in the burster tube and the lead cup.

*b. Safety Features.* The fuze M8 has four safety features:

- (1) The *safety pin* is a cotter pin passing through (off center) the body of the fuze and the retainer. The pin secures the retainer firmly to the body of the fuze and prevents its movement. Its function is to act as a reinforcement for the shear wire. Just before firing, the safety pin is pulled from the fuze by means of the ring attached to the pin.
- (2) The *shear wire* passes through the retainer and the fuze body. This prevents any movement of the retainer, even after the safety pin has been withdrawn, as long as the shear wire itself remains unbroken. The ends of the shear wire are bent into the annular groove around the outer surface of the retainer. This prevents accidental damage to the shear

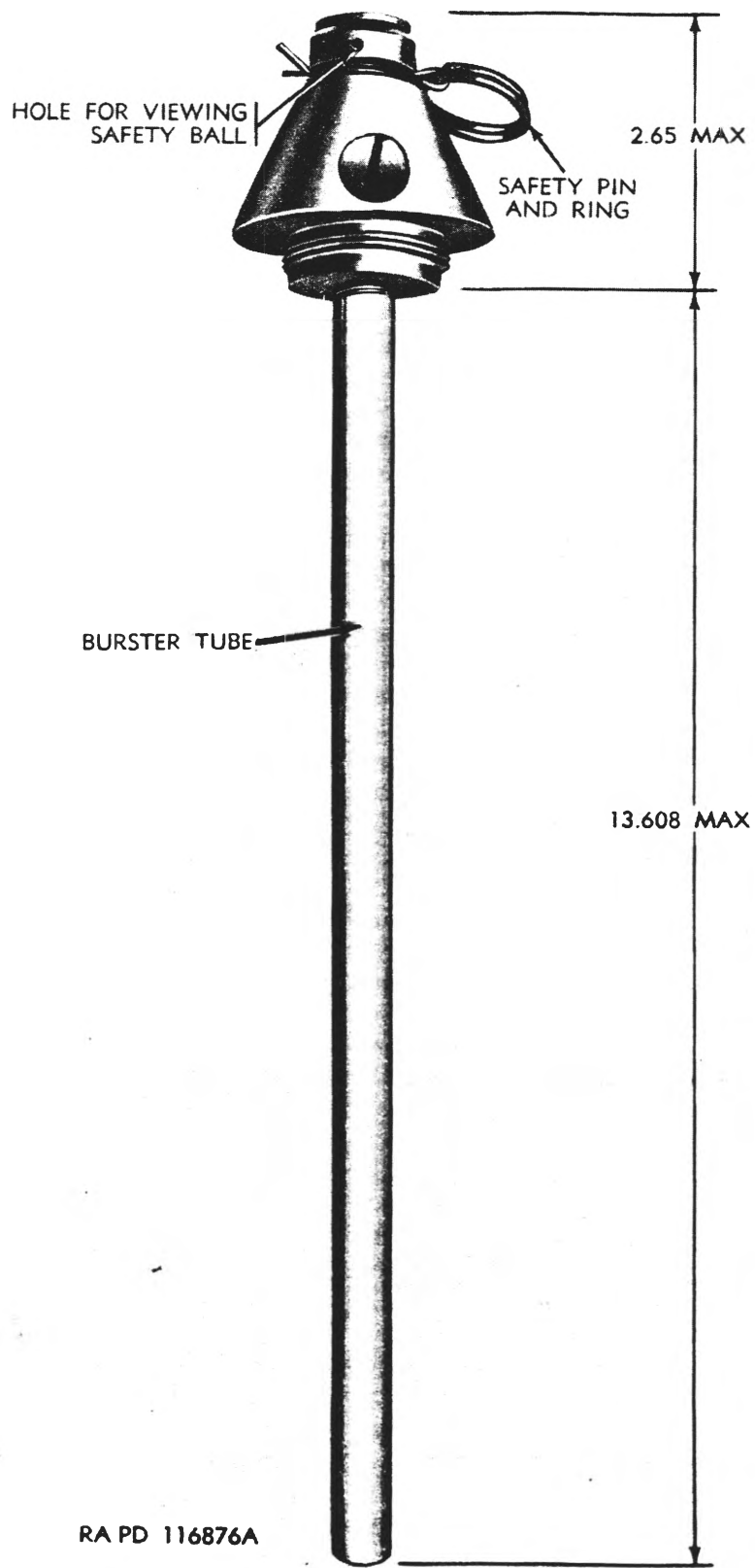

Figure 27. Fuze, point detonating: M8.



... of the fuze... (The text is extremely faint and largely illegible due to the quality of the scan. It appears to describe the internal mechanism of a fuze, mentioning components like a spring, piston, and detonator.)

*d. Operation in Detail.*

- (1) The main function is to see that the shear wheels in place are bent over at both ends and that the two steel balls are separated.
- (2) Locking mechanism in fuze may be constructed such pillars to facilitate rapid removal by mortar squad when needed.
- (3) Sufficient propellant charge is required.
- (4) Ignite and set pin just before ready to fire.

*e. Dimensions.*

Length	2.01 in.
Outer diameter	0.65 in.
Weight	1.7 GNS 2

**-1. Fuze, Point Detonating: M9**

The point detonating fuze M9 (fig. 28), which is also a 70-12-0 in high-explosive cartridge fuze, is similar to the fuze M8 described in paragraph 41 except that it has a booster instead of a fuze tube as in the case of the fuze M8. The composition-resistant metal booster tube of the fuze M9 is about equal in length to the fuze tube of the fuze M8. The fuze tube of the fuze M9 is a

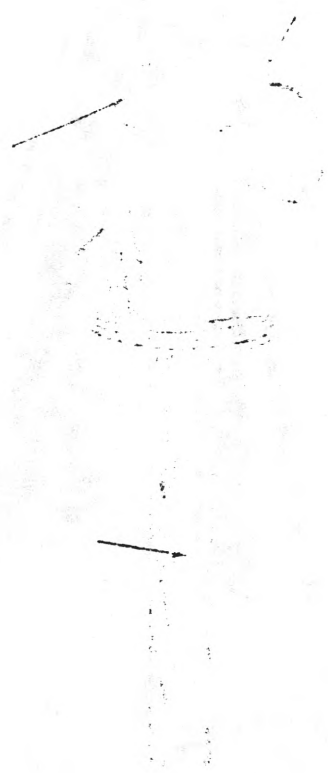
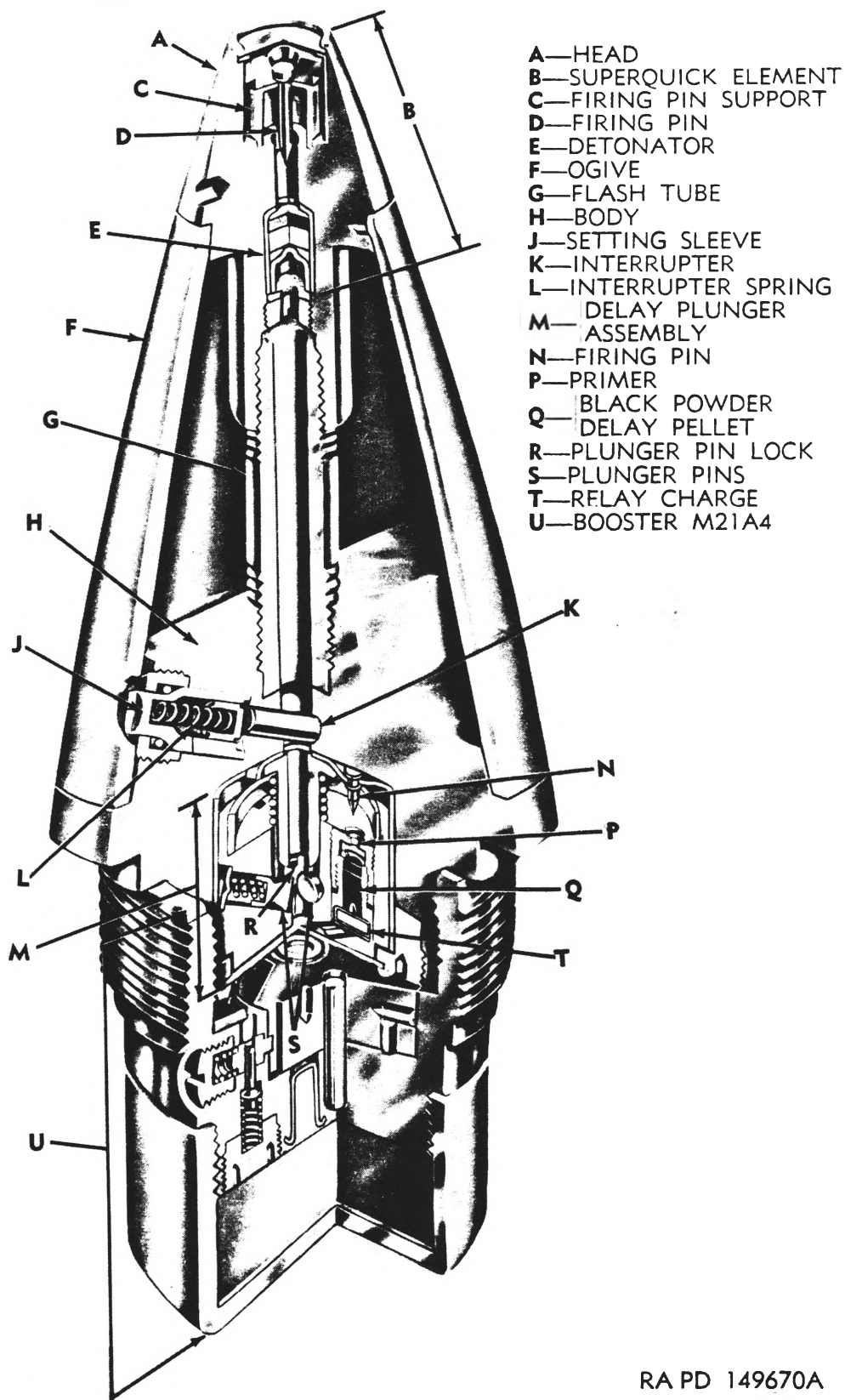

Figure 28. Fuze, point detonating: M9

booster in the fuze M9 is to transmit the shock action to the high-explosive (TNT) filler, which in turn bursts the projectile. The fuze M9 has the same safety features as the fuze M8 and functions in the same manner. The overall length of the fuze is 0.76 inches. For further information, refer to paragraph 40.

**42. Fuze, Point Detonating: M51A5, 0.05- Sec Delay**

*a. General.* The point detonating fuze M51A5 (fig. 29) is an impact-type fuze which may be adjusted prior to firing to function with superquick action or with a delay action of 0.05 second. It should be noted that if the fuze is set for superquick action and the action fails, the projectile will be detonated with delay action rather than become a dud. The booster M21A1 (para. 76) which is a



RA PD 149670A

Figure 29. Fuse, point detonating: M51A5, 0.05-sec delay.

component of the fuze, is assembled to the fuze at the time of manufacture. As shipped, the fuze is set for superquick action, that is, the slot in the head of the setting sleeve is parallel to the vertical axis of the fuze and is alined with the index mark for superquick (SQ) action.

*b. Data.*

Length:		
Visible -----		3.74 in.
Overall (including booster) -----		5.93 in.
Weight (including booster) -----		2.15 lb
Thread size (fuze) -----		1.7-14NS-1
Thread size (booster) -----		2-12NS-1

*Note.* The key letters shown in parentheses in *c* through *f* below refer to figure 29.

*c. Description.* The fuze consists of a head (A) which holds a superquick element (B), and a body (H) which holds a delay plunger assembly (M) and its housing, and a selective setting device (*d* below). These main assemblies are connected by a flash tube (G) which holds and supports the parts firmly in position, and by a thin-walled ogive (F) which gives further support and contour. The superquick element is comprised of a firing pin (D) supported by a cup-shaped gilding metal firing pin support (C) and a detonator (E). The firing pin support is sufficiently strong to withstand initial setback forces upon firing, but collapses under the force of impact at the target. The delay plunger assembly is an inertia plunger type and includes a firing pin (N), primer (P), black powder delay pellet (Q), and a relay charge (T).

*d. Setting.* The selective setting device consists of an interrupter (K), interrupter spring (L), and the setting sleeve (J). The head of the setting sleeve is slotted to facilitate turning when changing the setting. To enable exact alinement, two register lines and the marking "SQ" and "DELAY" are stamped on the ogive of the fuze. When the slot in the sleeve head is alined with the "SQ" line (parallel to the fuze axis) or within 15 degrees thereto, the setting sleeve, which is thicker on one side than on the other, is turned so that it does not interfere with movement of the interrupter. The interrupter is free, therefore, to move outward under centrifugal force and thereby open the passage for superquick action. When the slot is alined with the "DELAY" line (at right angles to

the fuze axis) or within 15 degree thereto, a section on the setting sleeve rests against the interrupter, securing it in the lower extremity of the recess across the superquick passage.

*e. Safety Devices.* Boresafe superquick action is provided by the interrupter (K). Boresafe delay action is provided by arrangement of mechanism within the booster M21A4 (U) (par. 76).

*f. Functioning.*

*Note.* Functioning described herein refers to PD fuze M51A5; for functioning of booster M21A4, refer to paragraph 76.

No action takes place in the fuse upon firing until sufficient rotational speed has been established to overcome the resistance of springs and setback force on the several safety devices. When set for superquick action, after the round leaves the mortar, centrifugal force causes the interrupter (K) to move outward, opening the passage. At the same time, the plunger pins (S) locking the delay assembly in unarmed position also move outward, releasing that assembly in preparation for impact. The plunger pin lock (R) then swings on its pivot under centrifugal force, placing an arm against the inner end of each plunger pin and thereby preventing the return of the pins to the unarmed position. Upon impact, the firing pin of the superquick element is driven against the detonator, initiating the superquick action. Inertia causes the delay action plunger to move forward, driving the primer against the delay action firing pin and initiating the delay action. In normal functioning with superquick action, the delay action has no effect since the superquick train will have caused the projectile to explode before the delay train can burn for its prescribed time. However, should the superquick action fail, the projectile will function with delay action rather than become a dud. When set for delay action, the interrupter which interrupts the superquick passage is restrained from moving. Upon impact, the superquick firing pin and detonator function but the effect is prevented from being transmitted to the projectile.

*g. Preparation for Firing.* The fuze need be adjusted only for the desired action, as described above. The setting can be changed at will (with the screwdriver end of fuze

wrench M18 or a similar tool) at any time before firing; this can be done even in the dark by feeling the position of the slot and making the correct setting.

*h. Precautions in Firing.* The precautions outlined in (1) and (2) below should be closely observed in order to prevent injury to personnel, damage to materiel, or malfunctioning of the ammunition.

- (1) If these fuzes are fired during extremely heavy rainfall, premature functioning may occur. The rainfall necessary to cause malfunctioning is comparable to the exceedingly heavy downpours which occur during summer thundershowers. Such prematures may be prevented by setting the fuze for delay action, making the superquick (SQ) action inoperative.
- (2) In order to prevent rounds falling as duds, 4.2-inch cartridges assembled with these fuzes should not be fired with less than seven increments of propellant.

#### 43. Fuze, Point Detonating: M52-Series

*a. General.* These fuzes are fitted to various 60-mm and 81-mm mortar cartridge as shipped. Renovated rounds and rounds of current manufacture are fitted with fuzes of the M525-series.

*Note.* Rounds on hand fitted with fuzes M52 series are issued for combat emergency only.

##### *b. Data.*

Length:		
Visible	-----	2.40 in.
Overall	-----	3.52 in.
Thread size	-----	1.5-12NF-1

*Note.* The key letters shown in parentheses in *c* and *d* below refer to figure 30.

*c. Description.* The fuzes M52 series are single-action superquick types with a direct action firing device. The fuze consists of two major parts: a head (D) which holds the firing pin assembly; and a body (M) which contains a slider (F), a detonator (J), a booster lead (K), and a tetryl booster pellet (L) in a booster cup (Q) screwed into the base of the fuze body. The firing pin assembly consists of a firing pin (C) secured to a cup-shaped striker (A). The striker is supported by a spring (B) which holds the firing pin at a safe distance from the detonator during the

flight of the projectile. The entire firing pin assembly is held within the fuze head by a pin (E) near the pointed end of the firing pin. Boresafety is provided by a slider-type interrupter which, in the unarmed position, holds the detonator out of alignment with the firing pin and the booster lead. The slider is locked in the unarmed position by a safety pin (G); the safety pin in turn is held in locking position by a setback pin (P). Positive safety during shipment and handling is provided by a safety wire (N) which prevents the setback pin from moving. This safety wire must be removed before firing.

*d. Functioning.* Upon firing, setback causes the setback pin to move backward against the resistance of the spring. This releases the safety pin, which is held in the fuze by the inner wall of the mortar tube but which is ejected from the fuze as the projectile emerges from the muzzle. This releases the slider (F) which then, guided by the guide pin (H), moves into armed position. Upon impact, the striker is driven inward, compressing its spring and carrying the firing pin against the detonator. Action of the detonator is transmitted through the booster lead to the tetryl booster pellet and thereby, to the bursting charge of the projectile.

*e. Preparation for Firing.* The fuze requires no preparation for firing other than removing the safety wire. This should be done just before firing and at no other time.

#### 44. Fuze, Point Detonating: M53A1

*a. General.* The fuze M53A1 (fig. 31) is provided for use with 81-mm high-explosive cartridges M56 and M56A1, when delayed functioning is desired.

##### *b. Data.*

Length:		
Visible	-----	2.35 in.
Overall	-----	3.47 in.
Weight	-----	1.06 lb
Thread size	-----	1.5-12NF-1

*Note.* The key letters shown in parentheses in *c* through *e* below refer to figure 31.

*c. Description.* The fuze is a single-action type with a direct-action firing device. The body mechanism therein is identical with that of the fuzes M52 series, except that the guide pin (L) in the fuze M53A1 serves as both a lockpin and guide pin. The steel head (D) is

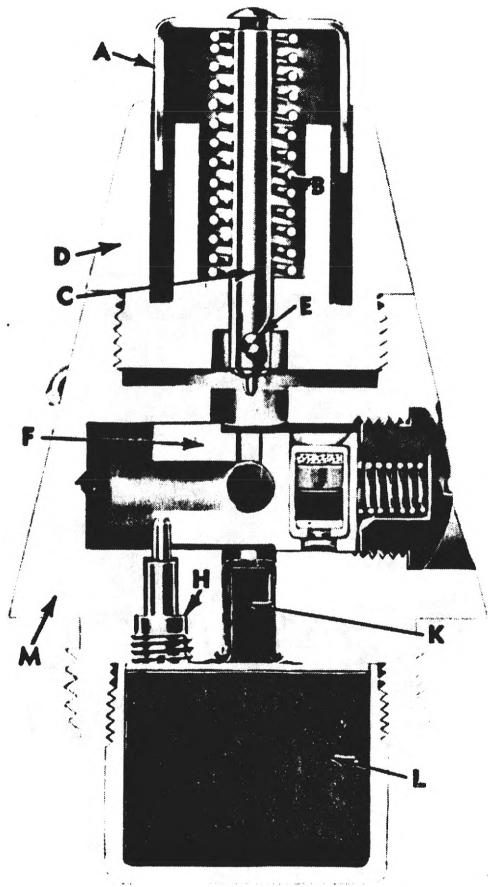

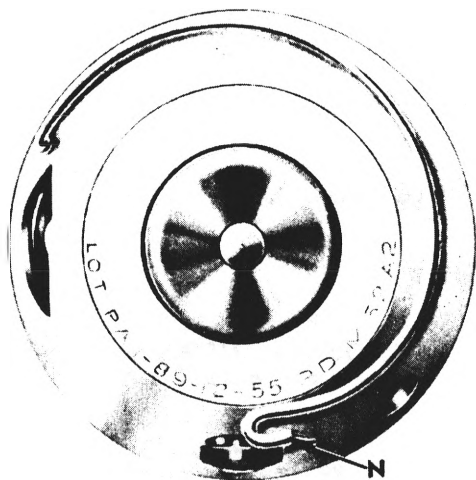

- A-STRIKER
- B-SPRING
- C-FIRING PIN
- D-HEAD
- E-PIN
- F-SLIDER
- G-SAFETY PIN
- H-GUIDE PIN
- J-DETONATOR
- K-BOOSTER LEAD
- L-TETRYL BOOSTER PELLET
- M-BODY
- N-SAFETY WIRE
- P-SETBACK PIN
- Q-BOOSTER CUP

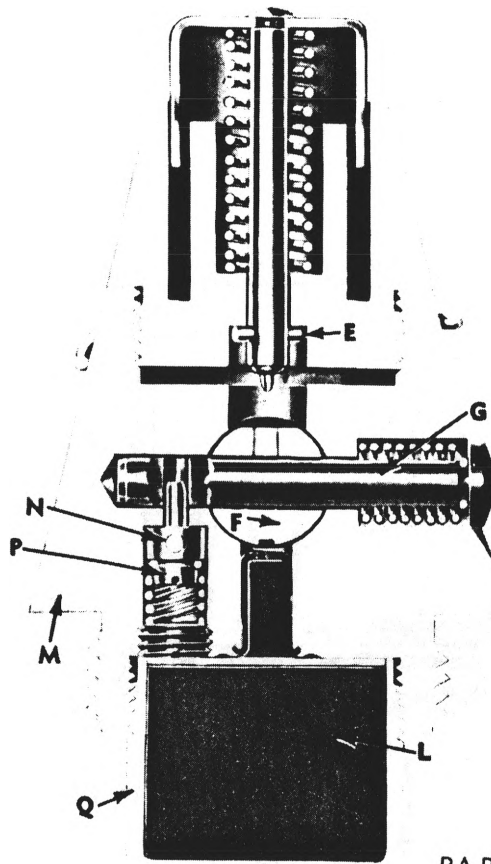

RA PD 80854C

Figure 30. Fuze, point detonating; M52.12.

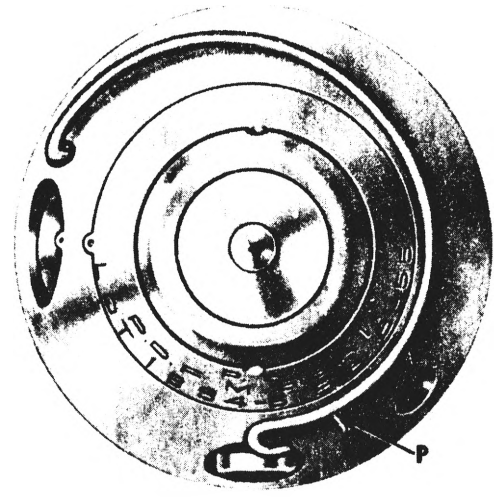
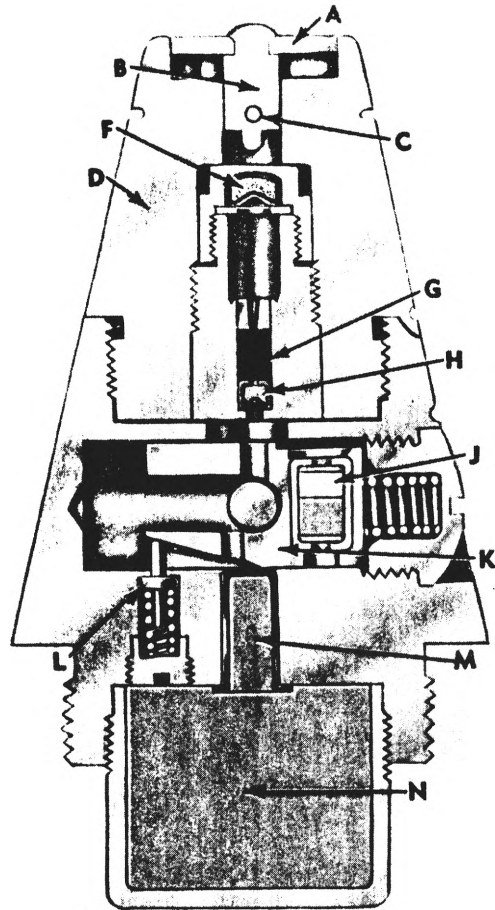

- A-DISK
- B-FIRING PIN
- C-SHEAR WIRE
- D-HEAD
- E-DELAY ASSEMBLY
- F-PRIMER
- G-PELLET
- H-RELAY CHARGE
- J-DETONATOR
- K-SLIDER
- L-PIN
- M-BOOSTER LEAD
- N-BOOSTER CHARGE
- P-SAFETY WIRE

Figure 31. Fuze, point detonating: M53.11.

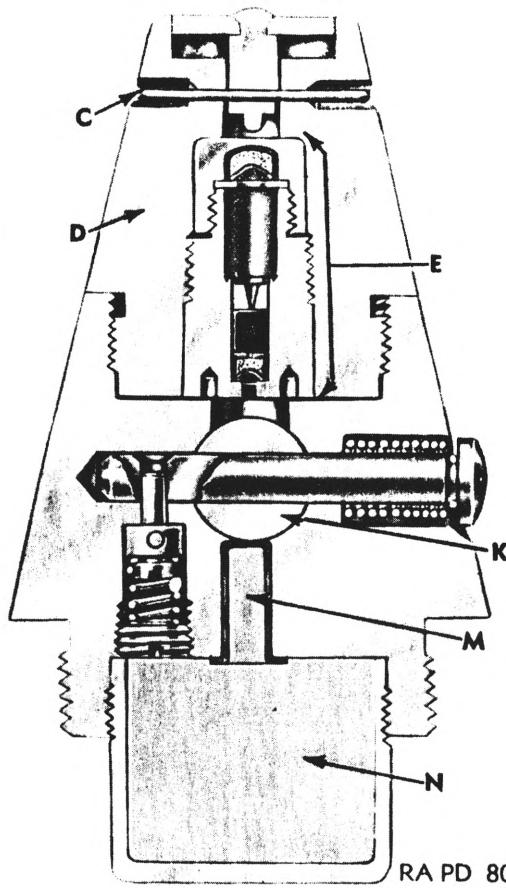

RA PD 80855B

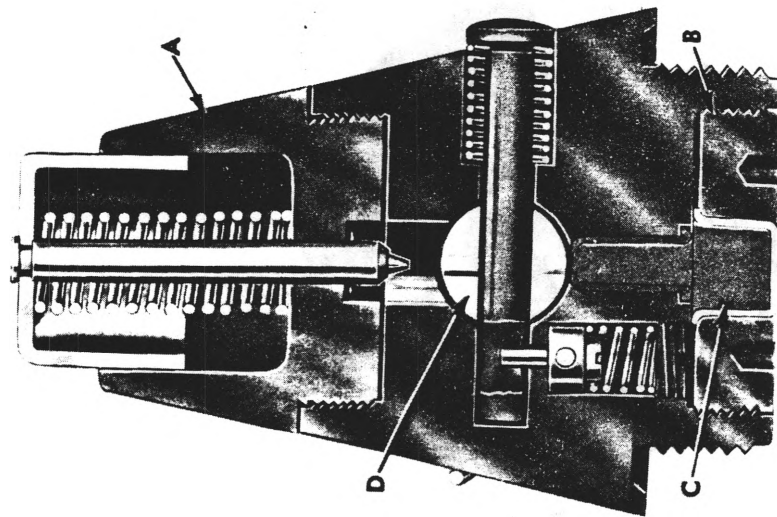

RA PD 108179B

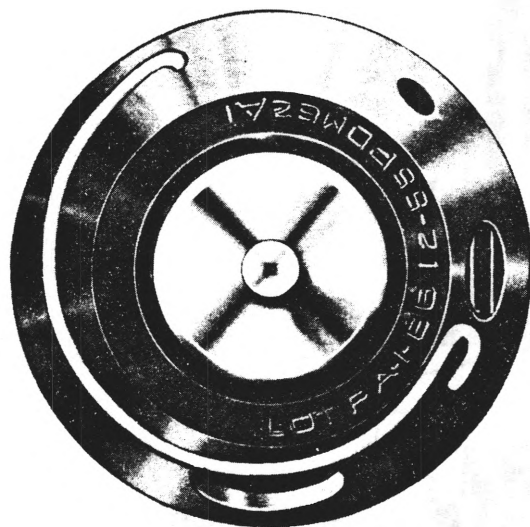

- A-HEAD
- B-SECURING PLUG
- C-BOOSTER CHARGE
- D-SLIDER

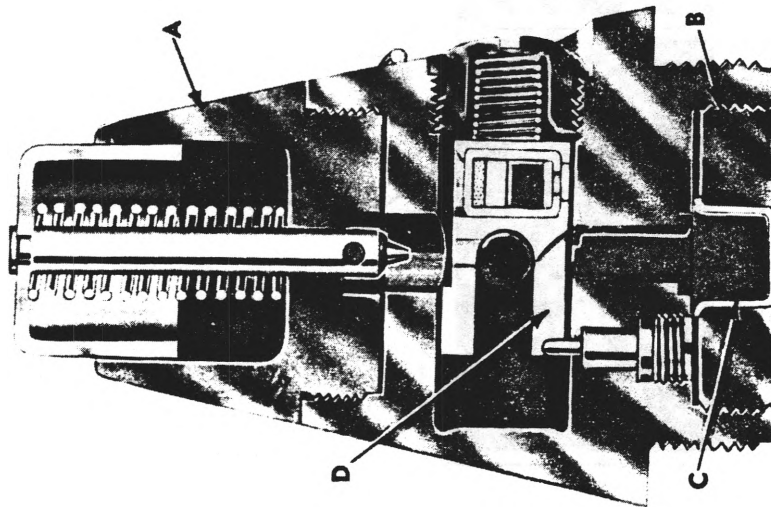
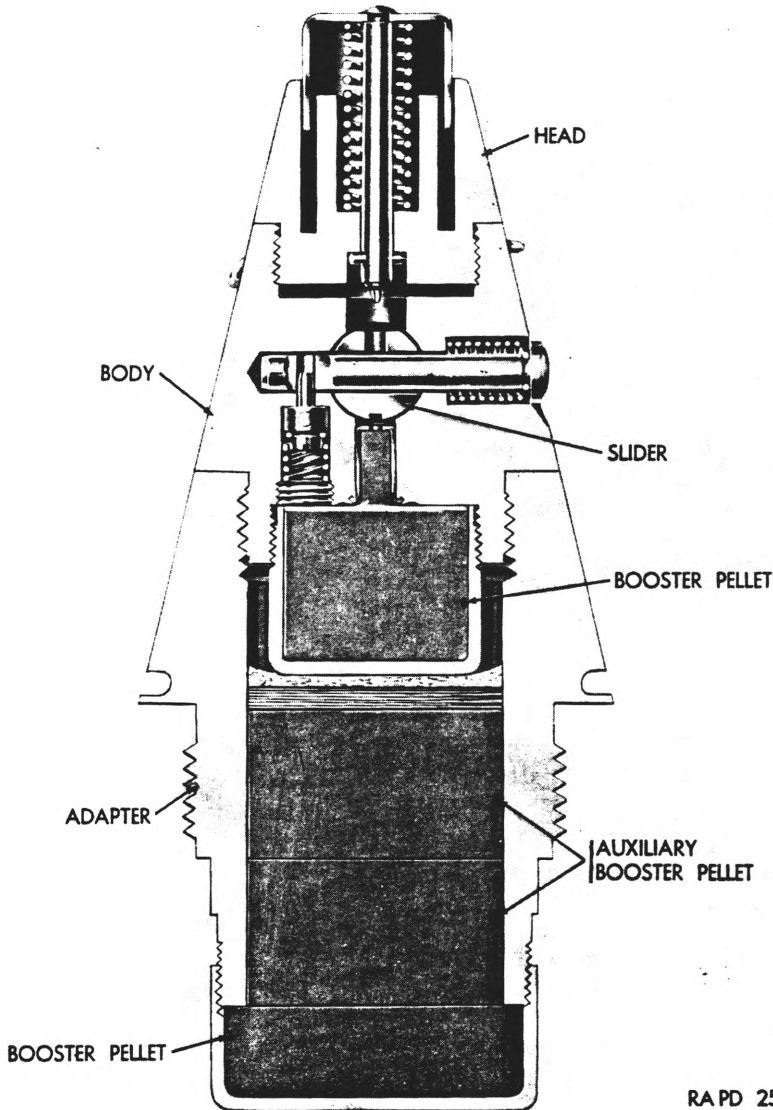
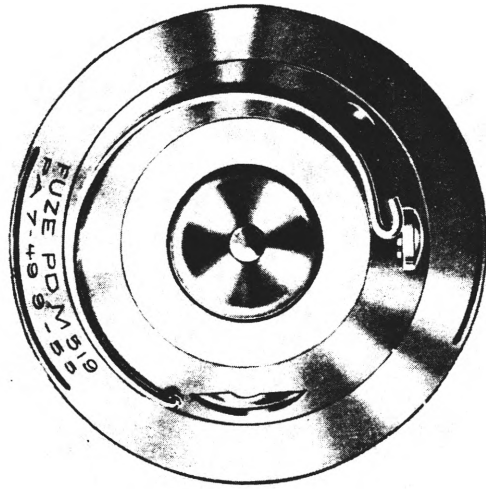

Figure 32. Fuze, point detonating: M82-11.



RA PD 253436

Figure 33. Fuze, point detonating: M519.

fitted with a delay assembly (E), and a short plug-type firing pin (B) with a nipple at one end and riveted at the other end to a thin aluminum-alloy disk (A) which forms the striker. Normally, the firing pin is held at rest by a shear wire (C). This wire is sufficiently strong to withstand ordinary blows and the setback created upon firing, but is sheared or bent upon impact at the target, allowing the nipple of the firing pin to come into contact with a primer (F) in the delay assembly. The delay assembly consists of the primer, a black powder delay pellet (G) which is loaded to cause the fuze to function with 0.1-second delay, and a relay charge (H) of lead azide.

*d. Functioning.* Upon impact, the firing pin is driven against the primer, which in turn ignites the black powder. After burning for the prescribed time, action of the lead azide relay is initiated. When the detonator (J) in the slider (K) has been brought into alignment in the same manner as the fuzes M52 series and locked in the armed position by the lockpin (L), action of the relay charge is transmitted to the detonator and thereby, to the booster lead (M) and booster charge (N). The booster charge, in turn, initiates the bursting charge in the projectile.

*e. Preparation for Firing.* There is no preparation other than the removal of the safety wire (P).

#### 45. Fuze, Point Detonating: M82, M82A1, or M82A1B1

*Note.* Rounds on hand fitted with fuzes M82 series are issued for combat emergency only.

*Note.* The key letters shown in parentheses below refer to figure 32.

*a. General.* The fuzes M82, M82A1 (fig. 32), and M82A1B1 are modifications of the fuze M52A1B1 to provide a small 10-grain booster charge (C) with brass securing plug (B) for use with the burster M19 in the smoke cartridge M302 for 60-mm mortars. A brass or zinc head (A) is employed. Functioning is the same as the fuzes M52 series. The fuze M82A1 differs from the fuze M82 in that the brass slider and detonator assembly M18 have been replaced by an aluminum slider (D) and detonator assembly M44.

*b. Data.*

Length:		
Visible	-----	2.36 in.
Overall	-----	2.86 in.
Weight	-----	0.47 lb
Thread size	-----	1.5-12NF-1

#### 46. Fuze, Point Detonating: M519

*Note.* Rounds on hand fitted with the fuze M519 are issued for combat emergency only.

*a. Description.* The point detonating fuze M519 (fig. 33), which is a combination of the PD fuze M52A2 and fuze adapter T211 for use with 81-mm HE cartridge M362, is a single-action type with a direct action firing device. The fuze consists of a head which contains a firing pin assembly, a body which contains a slider mechanism, detonator, booster lead, a tetryl-loaded booster cup, and an adapter assembled to the base of the body. Boresafety is provided by a slider-type interrupter which, in the unarmed position, holds the detonator out of alignment with the firing pin and booster. The slider is locked in the unarmed position by a bore-riding pin which in turn is held in place by a setback pin. A safety wire prevents movement of the setback pin during shipment and handling.

*b. Data.*

Length:		
Visible	-----	3.67 in.
Overall	-----	5.88 in.
Weight	-----	1.25 lb

*c. Preparation for Firing.* This fuze requires no preparation for firing except for the removal of the safety wire.

#### 47. Fuze, Point Detonating: M521 (T247)

*a. General.* This fuze (fig. 34) is an impact-type fuze, similar to the fuze M51A5 described in paragraph 42 except that it does not have a booster. The threaded fuze base (2-inch thread) is assembled directly into the projectile.

*b. Data.*

Length:		
Visible	-----	3.74 in.
Overall	-----	4.63 in.
Weight	-----	160 lb

*c. Preparation for Firing.* The fuze is set in the same manner as the fuze M535 (T177E3) described in paragraph 52.

#### 48. Fuze, Point Detonating: M524 (T186E11)

*a. General.* This fuze (fig. 35) is a dual-

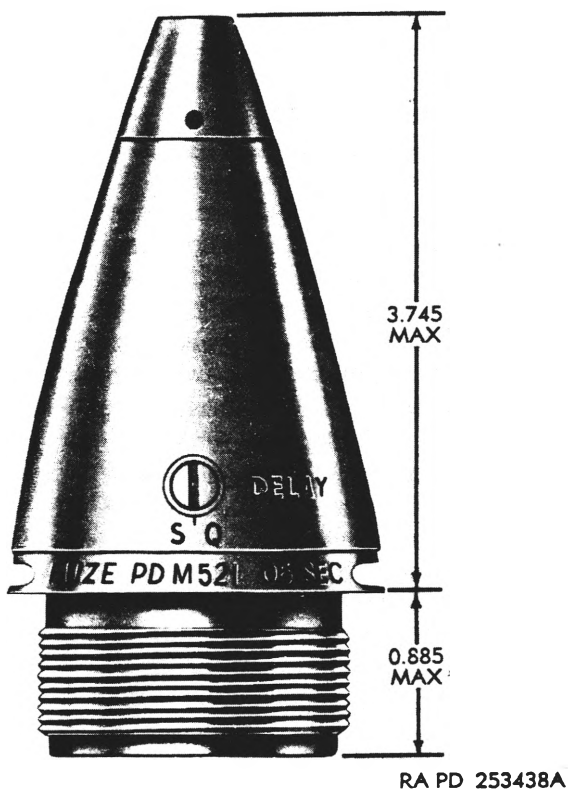

Figure 34. Fuze, point detonating: M521 (T247).

purpose fuze used with the 81-mm high-explosive (or target-practice) cartridge M362 or with the smoke WP cartridge M370. Alternative fuzes for these cartridges are PD fuze M526 (par. 50) or proximity fuze M517 (par. 58). The PD fuze M524 is designed for superquick impact action with greater sensitivity and speed than fuzes formerly used with 81-mm cartridges. The fuze PD M524 contains a delayed arming feature which insures that the fuze will remain unarmed and detonator safe for a minimum of 1.25 seconds of flight from the muzzle of the mortar but will arm within a maximum of 2.25 seconds from the mortar. The impact element contains firing pin assembly, the sensitive detonator T33E1, and the delayed arming mechanism consists of a spring-loaded setback operated rotor with T34E1 detonator, a setback device, and a timing device which controls the arming delay. An integral booster is in the bottom of the fuze.

*b. Preparation for Firing.*

- (1) Turn the slot in the striker (at the nose of the fuze) to align with the "SQ" index or the "D" index on the fuze body depending upon which action of the fuze is desired.
- (2) Remove the pull wire just prior to insertion of the round into the mortar.

*c. Data.*

Length (including booster) -----	5.96 in.
Intrusion -----	2.21 in.
Weight -----	1.27 lb
Thread size -----	2-12NS-1

**49. Fuze, Point Detonating: M525A1 and M525**

*a. Description.* These fuzes (figs. 36 and 37) are modifications of the fuzes M52 series. The modifications consist of the substitution (for the head of the fuzes M52 series) of a head assembly (fig. 38) containing a delayed-arming mechanism in addition to the firing pin mechanism. The modified fuze, which is designated M525 (fig. 36) for an earlier modification and M525A1 (fig. 37) for a later modification, may be described as a single-action superquick delayed-arming impact type consisting of the delayed-arming head (fig. 38) and the M52 body (fig. 30) containing slider, bore-riding pin, setback pin, and booster. The fuzes M525A1 and M525 are used with the 60-mm high-explosive cartridge M49A2, the 81-mm high-explosive and target practice cartridge of the M43 series, and the 81-mm smoke WP cartridges of the M57 series.

*b. Functioning.* Upon firing (after removal of the pull wire and safety wire) setback causes the setback pin to release the bore-riding pin, which moves outward to contact the bore of the mortar and is ejected as the cartridge leaves the mortar. Setback also frees the pallet and escape pinion wheel which begins to rotate a center gear of the delayed arming mechanism. This causes the firing pin to act as a detent to prevent the slider from moving the detonator into line with the firing pin. At the end of the delayed arming time, which is approximately 3 seconds after the cartridge has left the mortar and is at a safe distance from the firing crew, the lugs

(fig. 38) are alined with the slots. When this occurs, a spring causes forward movement of the firing pin withdrawing it from the slider. The slider then moves laterally under the action of the slider spring alining the detonator with the firing pin and the tetryl lead charge in the fuze body. Upon impact, the striker is driven against the firing pin spring, which forces the firing pin into the detonator, which detonates in turn the tetryl lead charge, tetryl booster and main bursting charge of the cartridge.

*c. Temperature Limits.* These limits for both storage and operation are  $-65^{\circ}$  and  $160^{\circ}$  F.

*Note.* Rounds on hand fitted with fuzes M52 series are issued for emergency combat only.

*d. Preparation for Firing M525, M526, and M527-Series Fuzes.* No preparation for firing is required except to remove the pull wire and safety wire, which is to be done only just before inserting the cartridge into the mortar.

*Note.* If, upon removal of the pull wire and safety wire, a buzzing sound in the fuze is heard, the round should not be used. Such round is still safe to handle

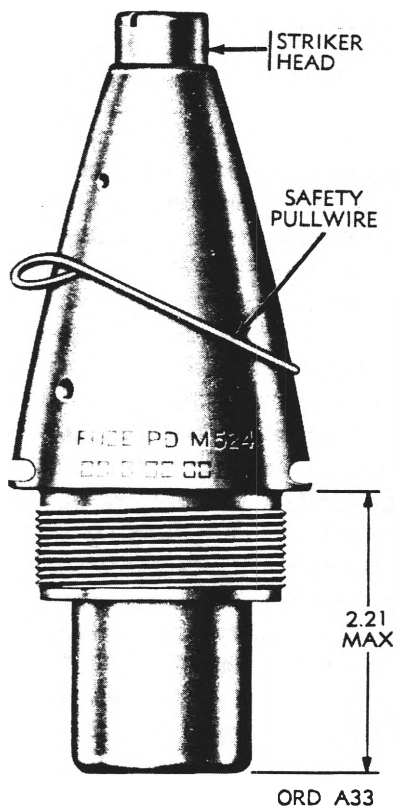
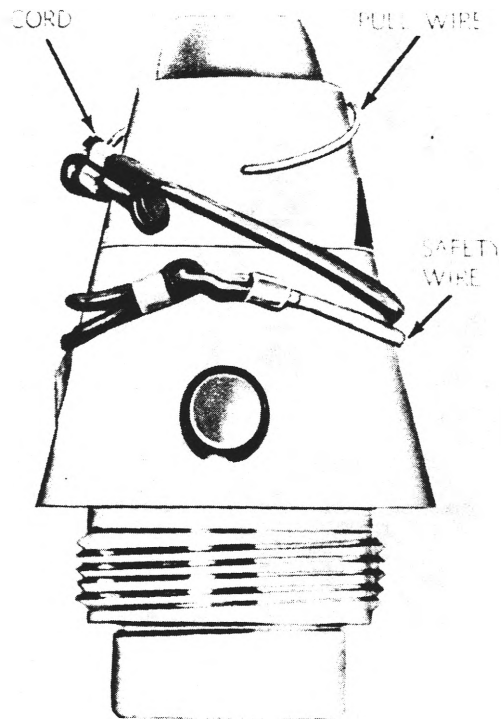

Figure 35. Fuze, point detonating: M524 (T186E11).



RA PD 257516

Figure 36. Fuze, point detonating: M525.

and transport provided the bore-riding pin is in position and the safety wire is reinserted.

*e. Data.*

Length (including intrusion) ----- 3.50 in. (max.)  
 Weight ----- 0.24 lb  
 Thread size ----- 1.5-12NF-1

**50. Fuze, Point Detonating: M526A1 (or M526)**

These fuzes (figs. 39 and 40) which are replacing PD fuze M519 (fig. 33) consist of the former M52-series, modified as in the case of PD fuze M525-series (par. 49), with an arming delay head and *in addition* fitted with an adapter containing auxiliary booster pellets to adapt it to high-explosive cartridge M362. This fuze may be used as an alternative for PD fuze M524 in 81-mm high-explosive cartridge M362. The same preparation for firing as in the case of M525 series fuzes applies.

*Note.* Rounds on hand fitted with PD fuze M519 are issued for emergency combat only.

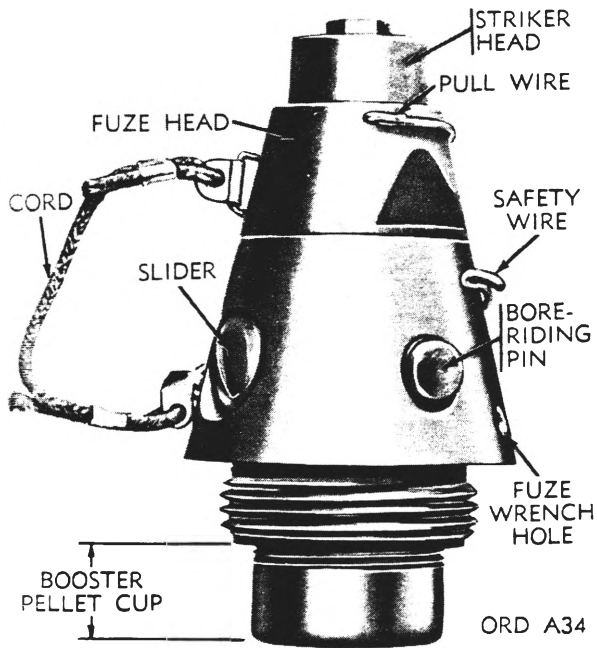

Figure 37. Fuze, point detonating: M525A1.

### 51. Fuze, Point Detonating: M527A1, M527 or M527B1, and M527A1B1

These fuzes (figs. 41 and 42) are replacing the M82 series. They are similar to the fuzes M525-series (par. 49) except that the fuzes M527-series have a smaller booster charge and an intrusion. They are for use with burster M19 in the 60-mm smoke WP cartridge M302. The M527 and the M527A1 have a plastic body and the M527B1 and the M527A1B1 have an aluminum body.

*Note.* Rounds (M302) on hand fitted with M82-series on M52-series fuzes are issued for emergency combat only.

### 52. Fuze, Point Detonating: M535 (T177E3), 0.05-Second Delay

This fuze (fig. 43) is an impact-type fuze which is similar to, and will replace, the point detonating fuze M51A5 (par. 42). The PD fuze M535, however, includes the booster M124 (T35E7) (par. 77). The threaded fuze has a 2-inch thread. Booster M124, which is a manufacturing component of the fuze M535, has an external thread and is screwed into the base of the fuze.

### 53. Fuze, Time (Fixed): M65A1 or M65

*Note.* The key letters shown in parentheses below refer to figure 44.

*a. General.* The fuze M65A1 (fig. 44) is a fixed time fuze used with the 60-mm illuminating cartridge to obtain the delay in functioning required for the most effective illumination. It differs from the adjustable powder-train types in that the burning time is fixed at approximately 15 seconds, and therefore does not have a movable time ring or require adjustment. This delay permits the round to be at its optimum range and height before the illuminant begins to burn. The fuze M65A1 differs from the fuze M65 in the following respects: the striker is longer; the body is recessed beneath the time-train ring to protect the felt pads which separate the body and ring; the fuze wrench holes in the body are replaced with two fuze wrench slots cut into the lower flange on the body; the time-train ring is slightly heavier; and the quickmatch is replaced by a black powder pellet (F.)

#### *b. Data.*

Length:		
Visible	-----	2.06 in.
Overall	-----	2.54 in.
Weight (M65 fuze weight 0.77 lb)	-----	0.74 lb
Thread size	-----	2-20NS-1

*c. Description.* The time train is a powder-train type consisting of a primer (E), black powder pellet (F), a time-ring charge (H) loaded for a prescribed time of burning, a body pellet (J), and an expelling charge (L). Powder elements other than the black powder pellet (F) and time-ring charge are held in a die-cast body. The black powder pellet and time-ring charge are assembled in the time-ring (G) which is essentially a large washer grooved and drilled to hold the charges. A head (D) seating the striker (C) screws onto a threaded neck on the body (K), holding the time ring in a fixed position. A safety (cotter) pin (A) and a shear wire (B) pass through the head and striker. The safety pin provides positive safety during handling prior to firing. The shear wire holds the striker at rest until broken or bent by setback forces on firing.

*d. Functioning.* Upon firing, setback causes the striker to move rearward with sufficient force to shear the shear wire and strike the

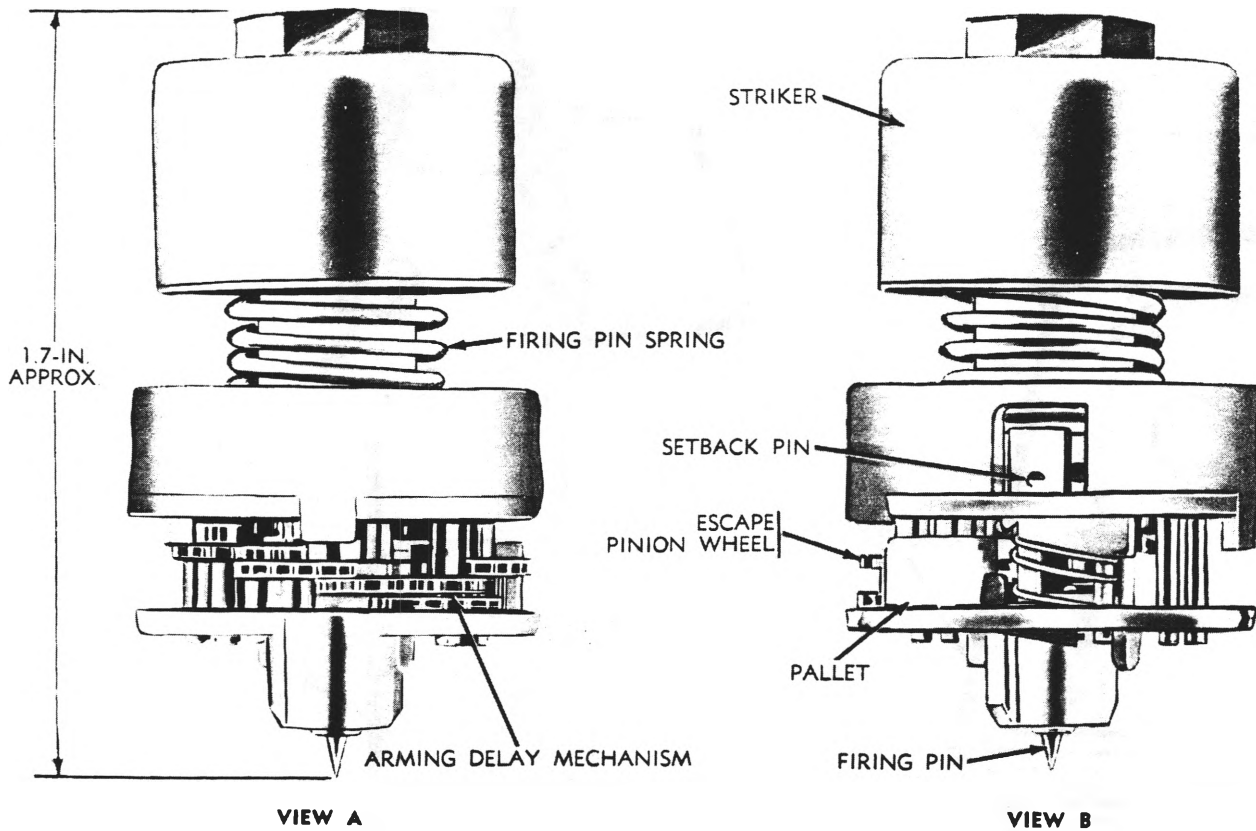

ORD A164

Figure 38. Head assembly—fuzes M525A1, M526A1, M527A1, and M527.11B1.

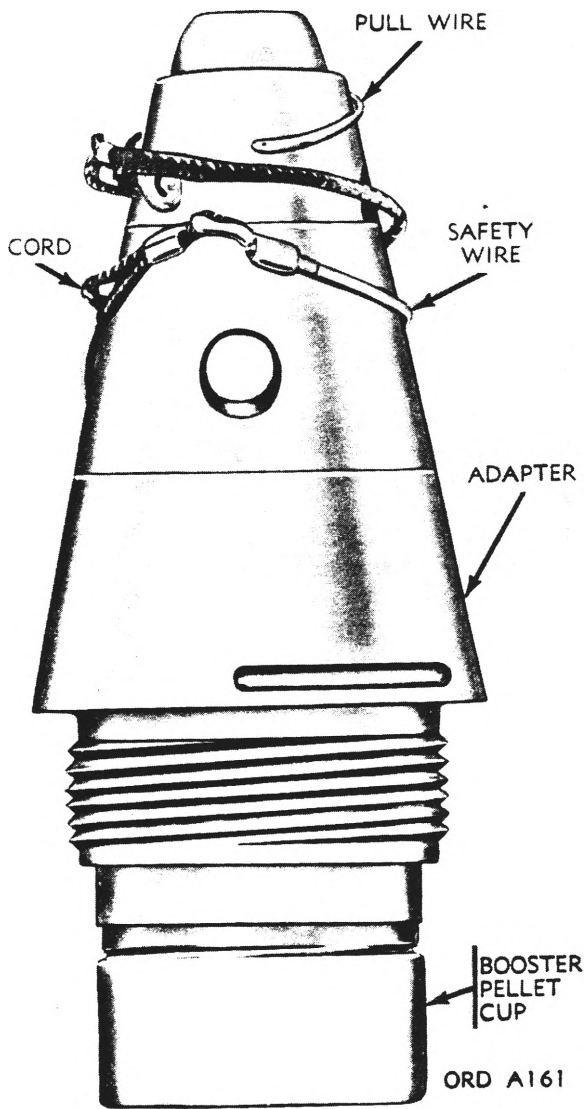

Figure 39. Fuze, point detonating: M526.

primer. The flame from the primer ignites the black powder pellet, which in turn, ignites the time-ring charge. After the flame from the time-ring charge has completed its circle about the time ring, it ignites the body pellet. The body pellet then ignites the expelling charge. Flame from the latter passes through the apertures in the expelling charge retainer disk (M), igniting the illuminant of the cartridge.

*e. Preparation for Firing.* There is no prep-

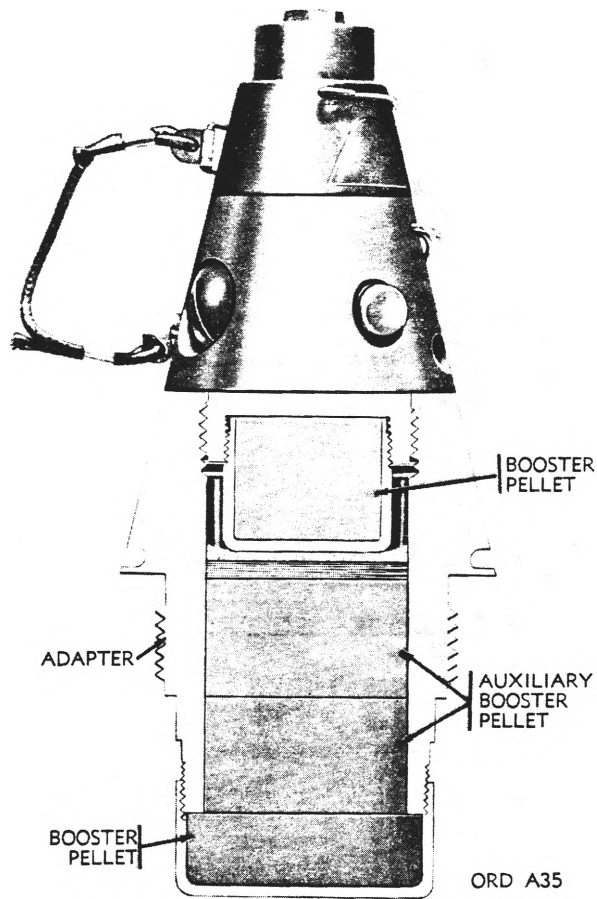

Figure 40. Fuze, point detonating: M526.11.

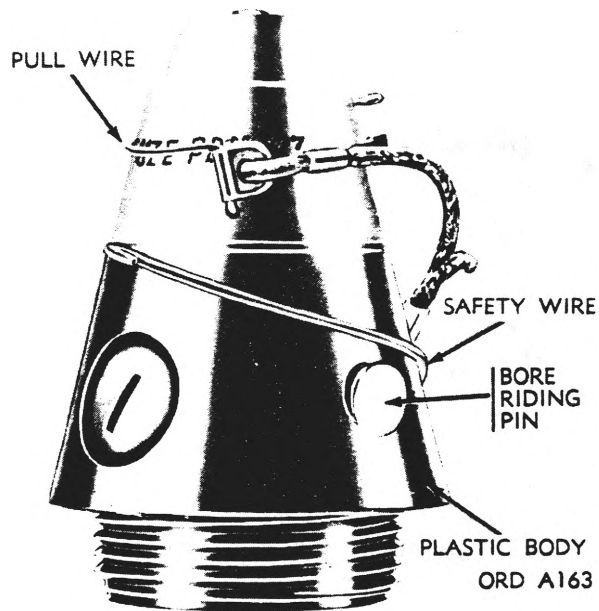

Figure 41. Fuze, point detonating: M527.

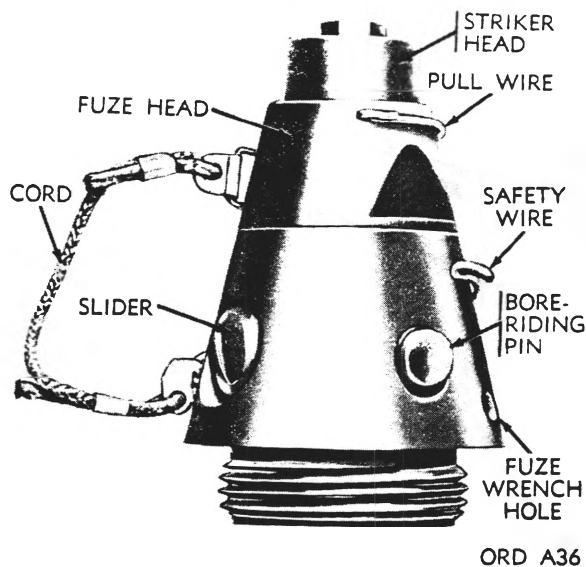

Figure 42. Fuze, point detonating: M527A1.

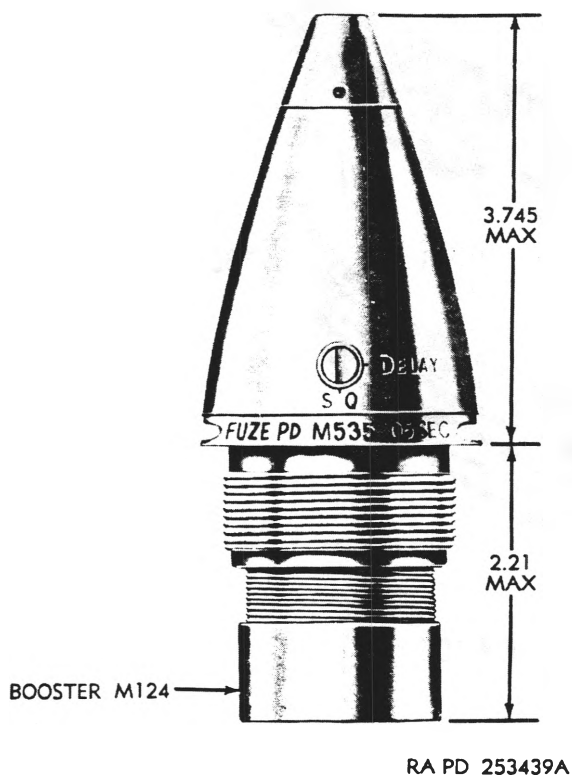

Figure 43. Fuze, point detonating: M535 (T177E3), 0.05-sec delay.

aration except the removal of the safety (cotter) pin, just prior to firing.

#### 54. Fuze, Time: M84

a. *General.* This fuze (fig. 45) is a single-purpose powder-train selective-time type fuze used with the 81-mm illuminating cartridge. It has a time setting up to 25 seconds.

##### b. Data.

Length:		
Visible	-----	3.25 in.
Overall	-----	3.85 in.
Weight	-----	1.82 lb
Thread size	-----	2.4-18NS-1

Note. The key letters shown in parentheses in c through e below refer to figure 45.

c. *Description.* The fuze consists of a brass head (A) which holds a time-action plunger (F), a body assembly (T) which holds the percussion primer (G) and expelling charge (S), the two inner time-train rings, and an outer adjustment ring (N) with six equally spaced vent holes (P). The head assembly screws onto the body and is further secured in the assembled position by a setscrew (H). The upper time-train ring (K) is secured in a fixed position by a lockpin (L). The lower time-train ring (M) is fixed to the outer adjustment ring by a lock screw (R) so that the two rings move in unison. A tension washer (J) is positioned between the head and the upper time-train ring. The fuze body is graduated from 0 to 25 seconds in 1-second intervals; 5-second intervals are indicated by bosses. The 0-second boss is of greater width and different shape than the other body bosses; "S" (safe) setting position is indicated by the letter S on the fuze body. The adjustment ring has six raise dribs (Q) for use in conjunction with the fuze setter M25, and a setting indicator rib (marked SET) of approximately half the height and width of the other six ribs.

d. *Safety Devices.* Safety prior to firing is provided for by a safety wire (C) which must be removed just prior to firing.

e. *Functioning.* After removal of the safety wire (C), the plunger (F) is held in a fixed position by two shear pins (E). Setback force upon firing causes the plunger to shear these pins (E) and to move to the rear along the plunger guide (B) until it strikes the primer initiating burning of the powder train of the

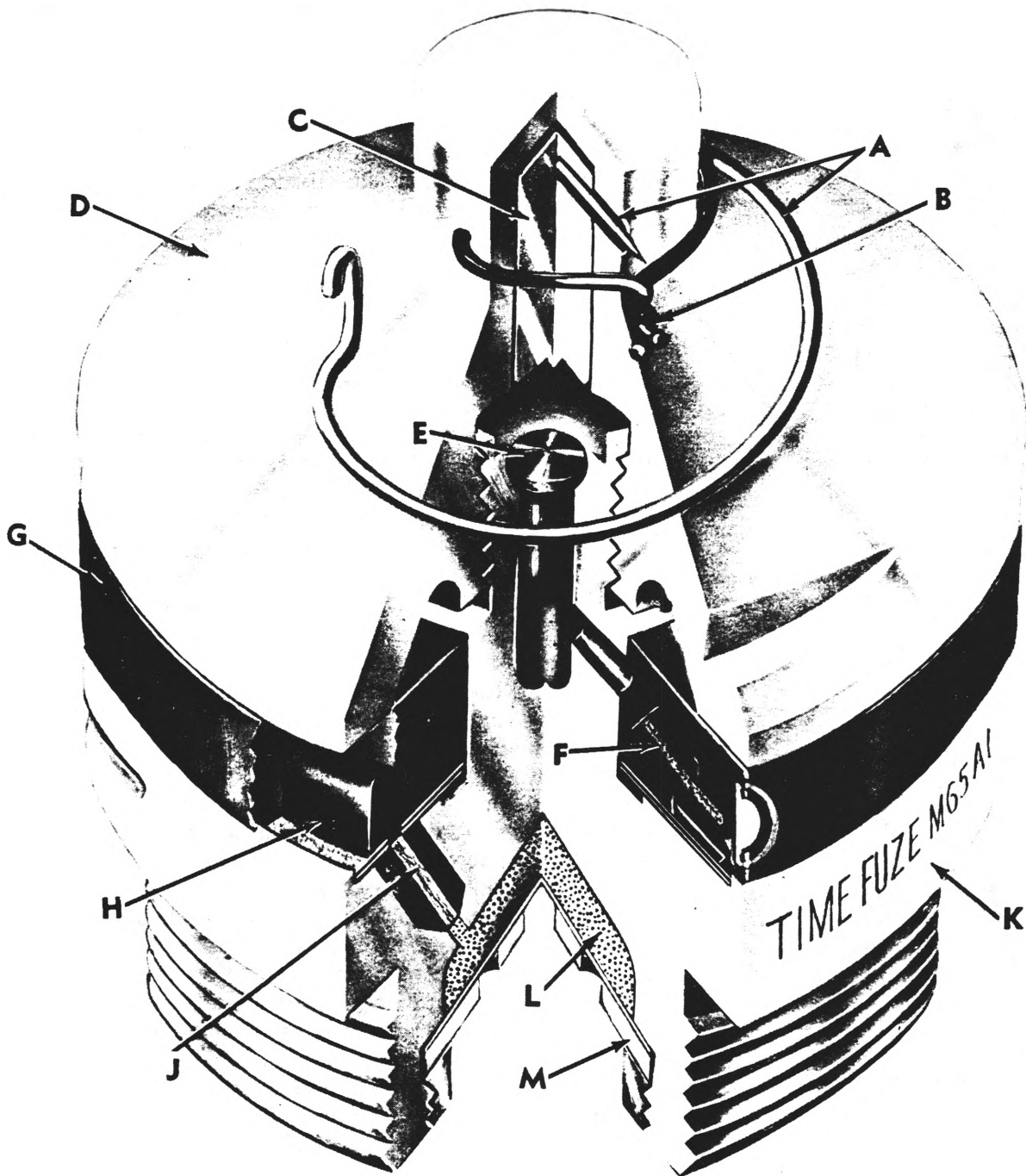

A—SAFETY (COTTER) PIN  
 B—SHEAR WIRE  
 C—STRIKER  
 D—HEAD  
 E—PRIMER  
 F—BLACK POWDER PELLETT

G—TIME-RING  
 H—TIME-RING CHARGE  
 J—BODY PELLETT  
 K—BODY  
 L—EXPPELLING CHARGE  
 M—RETAINER DISK

RA PD 80862B

Figure 44. Fuze, time (fixed): M65A1.

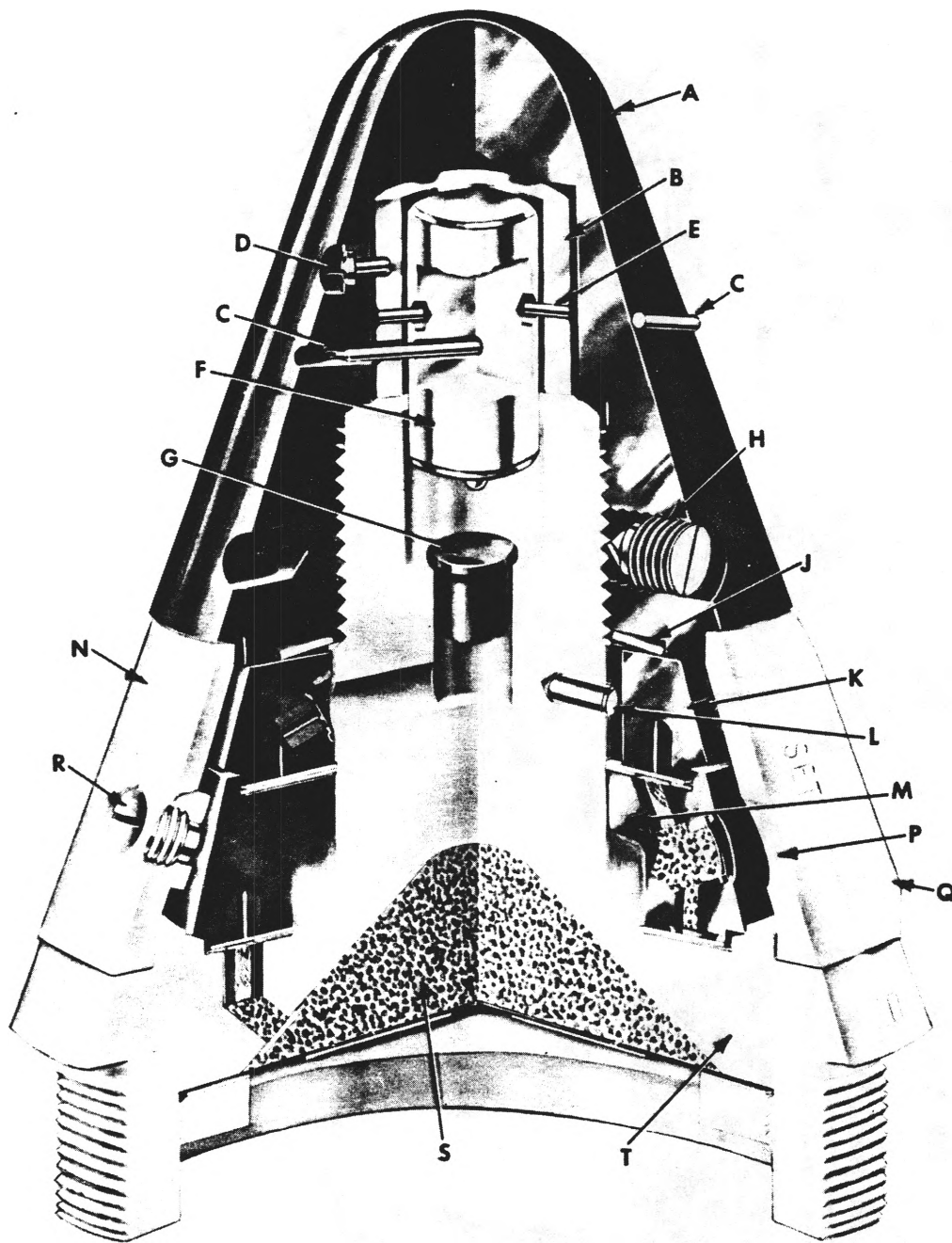

**A**—HEAD  
**B**—PLUNGER GUIDE  
**C**—SAFETY WIRE  
**D**—POSITIONING PIN  
**E**—SHEAR PIN  
**F**—PLUNGER  
**G**—PERCUSSION PRIMER  
**H**—SET SCREW  
**J**—WASHER

**K**—UPPER TIME-TRAIN RING  
**L**—LOCK PIN  
**M**—LOWER TIME-TRAIN RING  
**N**—ADJUSTMENT RING  
**P**—VENT HOLE  
**Q**—RIB  
**R**—LOCK SCREW  
**S**—EXPPELLING CHARGE  
**T**—BODY ASSEMBLY

RA PD 108180A

Figure 45. Fuze, time: M84.

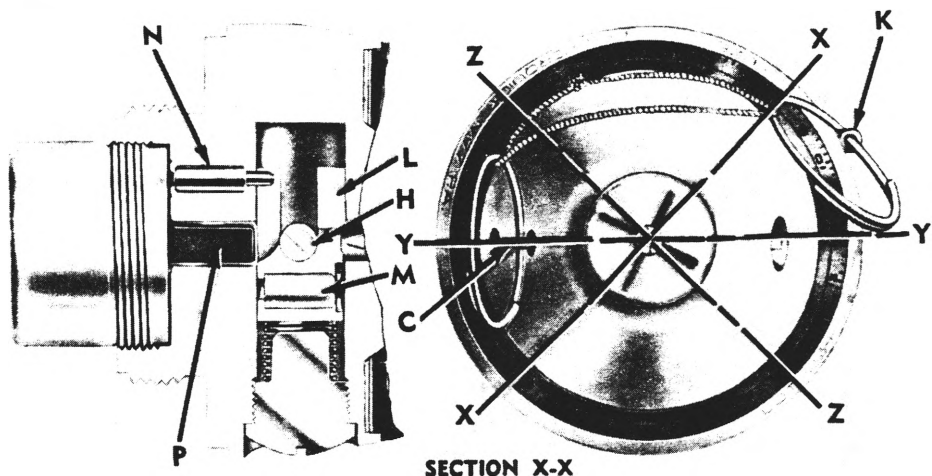

SECTION X-X

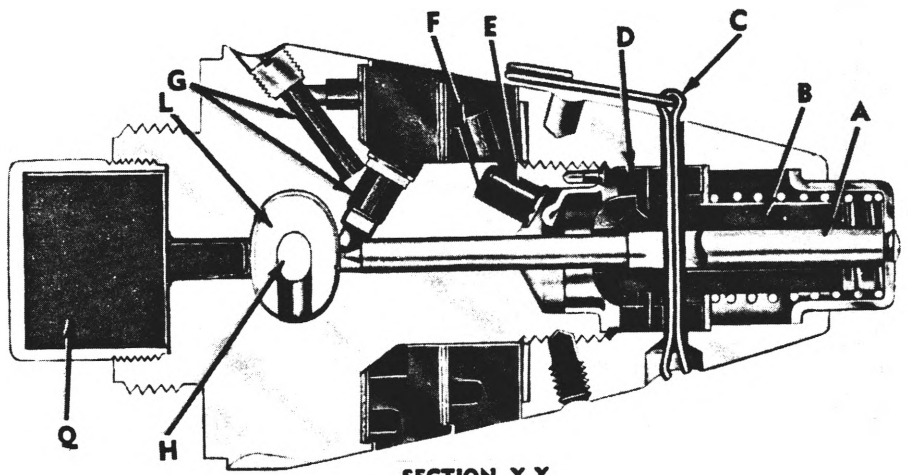

SECTION Y-Y

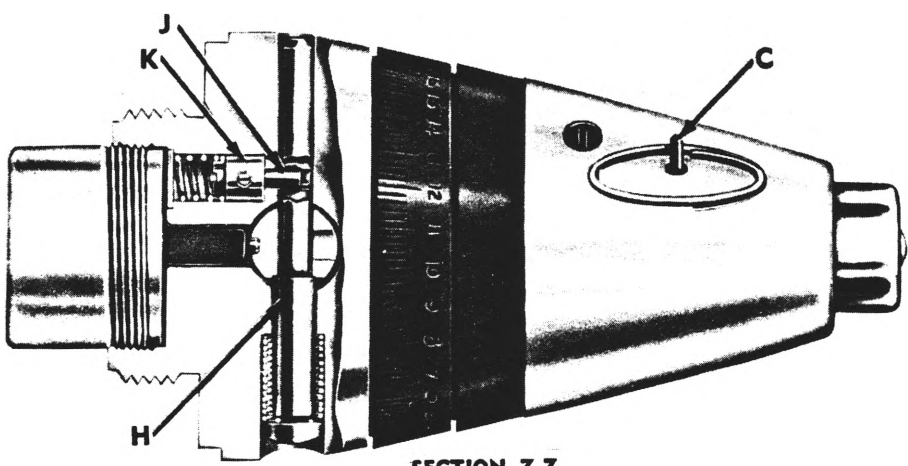

SECTION Z-Z

- |                    |                 |                   |
|--------------------|-----------------|-------------------|
| A—FIRING PIN       | F—PELLET        | L—SLIDER ASSEMBLY |
| B—PLUNGER ASSEMBLY | G—RELAY PELLETS | M—DETONATOR       |
| C—COTTER PIN       | H—SAFETY PIN    | N—GUIDE PIN       |
| D—SHEAR PIN        | J—SETBACK PIN   | P—BOOSTER LEAD    |
| E—PRIMER           | K—COTTER PIN    | Q—BOOSTER         |

RA PD 65178A

Figure 46. Fuze, time and superquick: M77.

time-train rings. A positioning pin (D) is provided for the plunger guide. After burning through a total length of powder train which is determined by the setting of the lower time-train ring as made by means of the adjustment ring, the burning train ignites the black powder pellet and expelling charge. The latter then produces the desired functioning of the cartridge.

*f. Preparation for Firing.* As shipped, the fuze is set SAFE, that is, the raised setting indicator on the movable adjustment ring is alined with the S on the body. To obtain the desired time of functioning, it is necessary to turn the adjustment ring with the fuze setter M25 provided for the purpose until the setting indicator on the adjustment ring is alined with the appropriate graduation or boss on the fuze body. Counterclockwise movement of the adjusting ring (viewed from the point of the fuze) increases the fuze time. The raised setting indicator and the fuze body bosses provide a means of setting the fuze in the dark. Just prior to firing, the safety wire must be removed.

### 55. Fuze, Time and Superquick: M77

*a. General.* This fuze (fig. 46) is a combination time and superquick fuze which provides either superquick impact action or time functioning for airbursts. It is used for 81-mm cartridges, HE, M56A1 and M56, and smoke, M57A1 and M57.

#### *b. Data.*

Length:		
Visible	-----	3.77 in.
Overall	-----	5.00 in.
Weight	-----	1.45 lb
Thread size	-----	1.5-12NF-1

#### *c. Description.*

- (1) The time element of this fuze consists of two powder time-train rings. The lower ring is graduated from 0 to 25 seconds, numbered every second and graduated every 0.2 second. A safe marking S and a O marking also appear on the lower ring. A slot in this graduated time ring and another in the body of the fuze are provided for setting the fuze by means of a fuze setter.
- (2) Impact action is obtained by setting the fuze to "S" or to any time set-

ting greater than the expected time of flight. When issued, the fuze will be found to be set to S. Superquick action is always obtained when functioned by impact.

*Note.* The key letters shown in parentheses in (3) *d*, and *e* below refer to figure 46.

- (3) The safety elements incorporated in this fuze consist of a bore-riding safety pin (H) similar to that in the fuzes M52-series and M53A1 and a shear pin (D) which supports the time action plunger. Two cotter pins with pull rings, secured together by a cord, are assembled to the fuze. The bore-riding safety pin passes through the slider assembly (L) carrying the detonator (M) which normally is out-of-line with the firing pin (A) and booster lead (P). A setback pin (J) secures the bore-riding safety pin in place and one of the cotter pins (K) passes through this setback pin, preventing accidental movement. The other cotter pin (C) passes through both the time-action plunger assembly (B) and firing pin, preventing premature movement of these assemblies. In addition, a spring supports the firing pin.

*d. Functioning.* Prior to firing both cotter pins must be removed by means of the pull rings. When fired, setback causes the time-action plunger to break the shear pin and strike the time-train primer (E) and ignite the time train through the pellet (F), provided a time setting of 0.8 second or more has been made. At the same time, setback retracts the setback pin (J) which releases the bore-riding safety pin (H). This pin is ejected by its spring from the fuze as soon as the cartridge leaves the mortar tube. The slider then is moved by its spring so that the detonator is in line with the firing pin and booster lead. A guide pin (N) keeps the slider assembly alined properly. If the fuze is set for time action, the powder train burns for the designated time and initiates the relay pellets (G) which, in turn, initiate the detonator. This detonates the booster (Q) and the filler in the cartridge. If the time setting is greater than the time of flight or if the fuze is set to

Upon impact, the firing pin is depressed against its spring and strikes the detonator in the slider assembly, which, in turn, initiates the booster and detonates the filler in the cartridge.

*c. Preparation for Firing.*

- (1) Examine fuze for the bore-riding safety pin (H). If not present, a report for disposition instructions will be made in accordance with TB 9-AMM-2.
- (2) Remove both cotter pins (C) and (K) by means of pull rings.
- (3) Set fuze for superquick impact or time action, as desired.

## 56. Proximity Fuzes

*a. General.* These fuzes are provided for use with 81-mm mortar high-explosive cartridge M362 and 4.2-inch mortar high-explosive cartridges M3A1 and M329. The fuze is essentially a self-powered radio transmitting and receiving unit. In flight, the armed fuze transmits radio waves. When any part of the radio wave front is reflected back from the target, it interacts with the transmitted wave. The ripple or beat caused by this interaction trips a switch thereby closing an electric circuit. This initiates detonation of the fuze explosive train which causes the projectiles to detonate when optimum distance from the target.

*b. Identification.*

- (1) *Alphabetical classification numbers and letters.* The alphabetical classification numbers and letters, which appear after the model designation on all packing boxes, metal containers, and proximity fuzes (e.g., M513/2, T226A, T226B) are of interest only to Ordnance ammunition personnel at the time of issue to using troops. Certain of the fuze characteristics are varied deliberately for technical reasons; these variations are indicated by the different classification letters. Whenever possible, two more of these classifications will be issued to each using unit, so that they may be fired concurrently by each battery. Such mixing will not affect operational effectiveness or

functioning characteristics of the fuzes.

- (2) *Designation.* The model of the fuze is stamped in the steel base of the nose. The caliber of the cartridge for which the proximity fuze is intended is stenciled on the cylindrical body of the M513-series fuzes.

*c. Special Instruction Card.* A special instruction card for each fuze lot is packed with boxes of proximity fuzes. The card will indicate any conditions of usage to be observed in firing and any deviation in performance from the "average." Proximity fuzes will be used in accordance with limitations listed on data cards and on appropriate firing tables.

*d. Characteristics.* Arming the impact element is delayed by a series of safety devices for at least 3 seconds after firing (regardless of time setting) for the fuze M513A1 (T226E2); until at least 3 seconds prior to the time setting for the fuze M513B1 (T226B1) or M513 (T226); for at least 1.5 seconds prior to the time setting of fuze proximity element is delayed for at least 3 seconds prior to the time setting of fuze M513A1 (T226E2), M513B1 (T226B1) or M513 (T226); for at least 4 seconds under normal conditions or 3.2 seconds under abnormal conditions for the fuze M517 (T178E3) (no setting required). The proximity fuzes are completely boresafe. Height of burst above the terrain of proximity fuzes varies with large changes in angle of fall, becoming lower as the angle of fall becomes steeper. These fuzes are designed to give optimum burst above average soil; however, the average height of burst is slightly higher over moist soil than over dry soil and 50 percent higher over marshy or very wet terrain than over dry land. The height of burst over body of water may be approximately two to four times the height of burst over land. Light tree foliage and vegetation do not affect the height of burst materially, but dense tree foliage and thick vegetation will increase the height of burst above ground. This effect is decreased at a steep angle of fall, in which case most projectiles will burst below treetop level. The dispersion in height of burst decreases as the time of flight is increased.

*e. Use.* The proximity fuzes may be used

as indicated in table IV.

Table IV. Authorized Use of Proximity Fuzes

Fuze	Weapon	Cartridge	Propelling charges	Minimum usable range (yd.)
M513A1 (T226E2) ----- M513B1 (T226B1) -----	4.2-inch mortar M30	M3A1 M329	More than 10 increments.	1,800
M513 (T226) M517 (T178E3) -----	81-mm mortars M1 and M29.	M362	Any charges	No minimum usable range.

*f. Care, Handling, and Preservation.*

(1) *Temperature.* Proximity fuzes and proximity fuzed rounds should be protected from long exposure to temperatures below  $-20^{\circ}$  and above  $\dagger 130^{\circ}$  F. for the M513-series; below  $-65^{\circ}$  and above  $\dagger 160^{\circ}$  for the M517 (T178E3). Proximity fuzes should not be used outside the safe temperature limits authorized ( $0^{\circ}$  to  $120^{\circ}$  F. for the M513 series and  $-25^{\circ}$  to  $\dagger 125^{\circ}$  F. for fuze M517 (178E3)).

*Note.* The safe temperature limits refer to the temperature of the fuze and not to the ambient temperature.

(2) *Weather conditions.* Darkness has no effect on the functioning of proximity fuzes. These fuzes are affected materially by rain or snow.

(3) *Moisture.* Although proximity fuzes are nearly waterproof, exposure to damp climates may affect serviceability. In temperate climates the fuzes M513A1 (T226E2), M513B1 (T226B1), and M513 (T226) may be expected to remain serviceable for 2 years or more, provided adequate protection is given the fuzes after containers are opened; the fuze M517 (T178E3) may be expected to remain serviceable for 6 months. The fuzes should not be removed from their original sealed containers, particularly in tropical climates, until just before use. Exposure to rain or immersion in water will result in accelerated deterioration.

(4) *Storage.* The precautions pertaining to other packed ammunition also

should be given to proximity fuzes. In addition, the storage temperature limits should be between  $-20^{\circ}$  and  $\dagger 130^{\circ}$  F. for the fuzes of the M513 series and between  $-65^{\circ}$  and  $\dagger 160^{\circ}$  F. for the fuze M517 (T178E3). Storage outside these limits for any length of time may result in permanent damage. The direct rays of the sun on proximity fuze containers or on poorly ventilated paulins may cause the temperature inside the individual containers to exceed the limits.

(5) *Resistance to shock.*

(a) Proximity fuzes will withstand normal handling without danger of their original packing containers or when assembled to cartridges. However, care should be taken not to strike or drop fuzes or fuzed rounds as these actions may increase the number of malfunctions. A drop of 4 feet may cause the electrolyte vial in the fuze battery of the fuzes of the M513-series to break, thus creating a dud. Excessively rough handling will not decrease fuze safety, but may increase the number of duds.

**WARNING:** In the event the proximity fuze M517 (T178E3), either packaged separately or assembled to a cartridge, is dropped 40 feet or more, as might possibly occur in loading or unloading of ships, the dropped fuze (M517 (T178E3)) or fuzed cartridge with M517 (T178E3) should not be

approached or disturbed for at least 30 minutes. ALL PERSONNEL SHOULD BE EVACUATED IMMEDIATELY FROM THE AREA TO A POINT COMMENSURATE WITH THE QUANTITY-DISTANCE REQUIREMENTS ESTABLISHED IN TM 9-1903 FOR TOTAL QUANTITY OF EXPLOSIVES THAT COULD BE INVOLVED IN AN EXPLOSION. (This quantity might vary from that contained in one box to the amount in the shipload or more.) After the 30-minute waiting period, the dropped fuze (M517 (T187-E3)) or fuzed cartridges (with M517 (T178E3)) is still dangerous but may then be approached and removed carefully and destroyed in a safe place. All operations connected with this procedure should be done either by, or under direct supervision of, personnel who are thoroughly familiar with the dangers of such an operation and who are qualified to do this work. If the situation permits a longer waiting period, 40 hours should be allowed prior to approaching the dropped fuze (M517 (T178E3)) or fuzed cartridge (with M517 (T178E3)) for its removal. It must be remembered that the dropped fuze or fuzed cartridge is still dangerous after this 40-hour waiting period but it may be handled with comparative safety.

- (b) Supplementary charges (if present which have been removed from the projectiles, prior to assembling proximity fuzes, will be packed in the containers from which the proximity fuzes have been removed. The containers should be properly marked and returned to an Ordnance ammunition depot for disposition.
- (c) Proximity fuzed ammunition may be safely transported short distances with normal care and handling. However, when such ammunition is to be transported considerable distances, it is advisable to remove the fuze from the round and return the fuze to its original

marked container. The supplementary charge (if present) and original fuze or closing plug (with gasket and spacer) should be reassembled to the round, making certain that the supplementary charge is properly inserted (felt-pad end innermost).

- (d) Rounds assembled with proximity fuzes must be adequately padded if temporarily placed in fiber containers. The U-shaped support, which engages the wrench slots of nonproximity point fuzes, will fit the fuze wrench slots of the proximity fuzes. The primer and propelling charge on such rounds must also be protected from damage or accidental functioning when the cartridge is placed temporarily in a fiber container.
  - (e) If proximity fuze M517 (T178E3) is to be delivered by paradrop, the boxed fuzes should be dropped in the "nose down" position. If the boxes are damaged as a result of a paradrop, the fuzes should not be used.
- (6) *Recovery of duds.*
- (a) *Assembled with proximity fuze M513 series.* Unlike other artillery fuzes, these proximity fuzes may be considered safe for handling 24 hours after the round has been fired, but they should be handled with care since they contain an armed explosive train, a booster charge, and an impact element.
  - (b) *Assembled with proximity fuze M517 (T178E3).* Rounds assembled with this proximity fuze contain a complete explosive train and impact element.

**WARNING:** These rounds should not be approached or disturbed for at least 30 minutes. After the 30-minute waiting period, the dud is still dangerous but may be approached carefully for destruction in place. If it is impossible to destroy in place, the dud should be removed carefully for subsequent destruction. If the situation permits a

longer waiting period, 40 hours should be allowed prior to approaching the dud for destruction in place or for removal. It must be remembered that the dud is still dangerous after this 40-hour waiting period but may be handled with comparative safety. All the operations connected with the above procedures should be performed by qualified disposal personnel.

### 57. Fuze, Proximity: M513A1 (T226E2)

*a. General.* This "adjustable delay arming" type of fuze (fig. 47) is provided for use for the engagement of terrestrial targets. The fuze may be identified by the markings thereon. The metal base is provided with a graduated time scale; time scale graduations are from 5 to 100 seconds. A movable time ring with register line is used to set the fuze to the appropriate time. A superquick element is mounted internally in the nose of the fuze. Since this fuze is for the engagement of terrestrial targets, no self-destruction element has been provided. The set time should usually be the same as the "time-to-target," to insure maximum time of unarmed flight of the proximity element. When set on 5 to 100 seconds the proximity element becomes armed approximately 3 seconds prior to the set time. The proximity element will function on proximity approach (at optimum distance) to any land or water mass. The impact and proximity circuits are armed independently. While proximity arming is a function of time setting, impact arming occurs independently at approximately 3 seconds; when set in the slot (notch) on "PD," the proximity portion is not activated and the fuze will function as a PD fuze. There is little hazard in firing these fuzes over friendly territory, except in the case of personnel or installations close to the target areas. If personnel are in the target area, proper consideration should be given to the instructions in (1) through (5) below.

- (1) Avoid firing at targets that are too close to friendly positions; the projectile should burst not closer than 350 yards from such positions.
- (2) If firing over crests or ridges, arming should be delayed until the projectile has passed the irregularity,

unless the irregularity should be cleared by 70 yards or more. Any fuze set for delayed arming may function upon impact with the irregularity.

- (3) When projectiles are approaching the target area at small angles of approach, the area between the point of full arming of the proximity element and the target may be sprayed by fragments from occasional early bursts. At larger angles of approach, any such projectile fragments decelerate and usually reach a state of essentially free fall and do not constitute a serious hazard.
- (4) When set for delayed arming, observation posts may safely be used to direct fire but they should avoid the region between the mortar and the target. The part that is close to the target should particularly be avoided. To avoid danger from normal or early bursts, aircraft should approach the trajectory or target area *not closer than 350 yards*.
- (5) The fuses M513B1 (T226B1) and M513 (T226) differ primarily from the fuze M513A1 (T226E2) in that when the fuze is set on 5 to 100 seconds, the *proximity element and the impact element* become armed approximately 3 seconds prior to the set time. The fuze M513 (T226) is  $\frac{1}{2}$  pound heavier than the fuzes M51A1 (T226E2) and M513B1 (T226B1). The fuzes M513 (T226) and M513B1 (T226B1) have an S (shipping line) marking in the slot (notch) instead of PD as in the case of the fuze M513A1.

#### *b. Data.*

Length:	
Visible	3.74 in.
Overall	8.6 in.
Weight (approx equal to the weight of an artillery fuze and supplementary charge).	
	2.8 lb
Thread size	2-12NS-1

*c. Preparation for Firing.* Tome settings are made in the same manner as for the mechanical time fuze, namely, while looking axially at the nose of the fuze, rotate the fuze setter M14 or M27 in a clockwise direction.

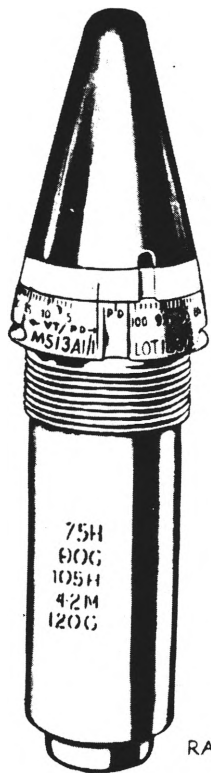

Figure 47. Fuze, proximity: M513A1 (T226E2).

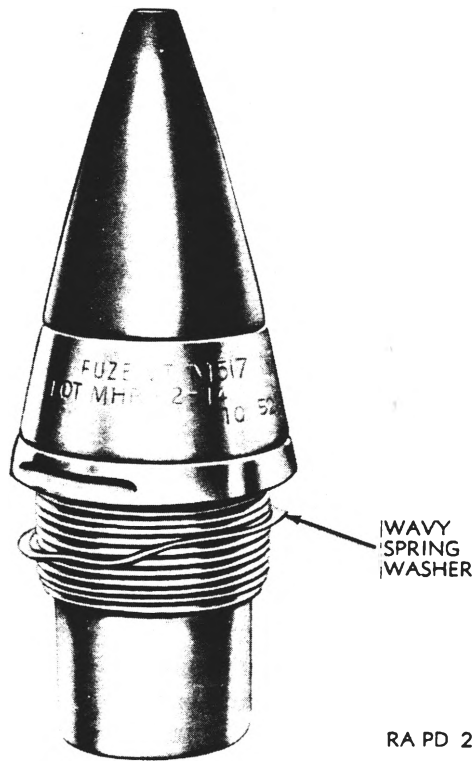

Figure 48. Fuze, proximity: M517 (T178E3).

### 58. Fuze, Proximity: M517 (T178E3)

*a. General.* This proximity fuze (fig. 48) is used with the 81-mm high-explosive cartridge M362 against terrestrial or waterborne targets. The fuze is essentially a self-powered radio pulse transmitting and receiving unit. In flight, the armed fuze transmits radio waves. When the radio pulse front is reflected back from the target, it interacts with the transmitted wave. When the ripple or beat caused by this interaction reaches a predetermined intensity, it trips an electronic switch which closes an electric circuit. This initiates detonation of the fuze explosive train when at or near optimum distance from the target. If the radio elements of the fuze should become inoperative, the impact element will cause functioning of the fuze explosive train if impact with a resistant object occurs.

*b. Description.* The proximity fuze consists of a conically shaped plastic nose molded to a threaded steel fuze body and a metal cup as-

sembly. The plastic nose encases the electronic head. The power supply is housed in the fuze body. The safety and arming mechanism is in a metal cup at the base of the fuze. The fuze is fitted to the projectile with a wavy spring washer. The washer is used for the purpose of insuring a tight fuze-to-projectile joint.

#### *c. Data.*

Length:	
Visible (when assembled to cartridge) _____	3.98 in.
Overall _____	6.19 in.
Weight _____	1.28 lb
Thread size _____	2-12NS-1

*d. Arming System.* The arming system consists of electrical arming and mechanical arming ((1) and (2) below). To insure safety in use and handling, several safety features have been incorporated into the fuze.

(1) *Electrical arming.* Safety in electrical arming is provided by the power supply. Since a setback force of a prescribed magnitude sustained over a predetermined time interval is re-

quired to activate the power supply, the fuze is safe in use and handling.

- (2) *Mechanical arming.* Safety in mechanical arming is provided by a setback left assembly. In the safe position, the spring-driven rotor (with its detonator) is locked in its out-of-line position, so that both the explosive train and the electrical circuits are interrupted. Since a setback force of a prescribed magnitude sustained over a prescribed time interval is required to cause the setback leaves to fall in sequence and release the rotor, the fuze is safe in use and handling. When the rotor is released, it turns and completes the explosive train and the electric circuit of the detonator. However, this action is not completed until the fuzed cartridge leaves the weapon.

*Note.* The fuze is not fully armed until both electrical and mechanical arming have taken place.

*e. Arming Time.*

- (1) *General.* The time required for the power supply to rise to its minimum operating value and for the firing capacitor to absorb sufficient energy to fire the detonator varies over the range of operating temperatures of the fuze. In general, longer arming times may be expected at lower temperatures and shorter arming times at higher temperatures.
- (2) *For impact action.* The minimum time after firing to arming for an impact function is in excess of 1.5 seconds.
- (3) *For proximity action.* The minimum time after firing to arming for proximity function (or early burst) is 4.0 seconds, under normal conditions; under unusual combinations of circumstances, occasional proximity function may occur as early as 3.2 seconds after firing. For normal fuze operation, the arming time is actually the electrical arming time.
- (4) *Impact action.* The impact element is designed to cause normal functioning of the cartridge on impact whenever certain types of failures oc-

cur in the electronic head. When the fuzed cartridge strikes a sufficiently resistant object, the circuit which permits the energy from the firing capacitor to flow through the electric detonator is closed. However, impact action can occur only after a fuze is armed ((2) above).

*f. Burst Height.* The principal factors affecting height of burst are: the angle of approach to the target and the reflectivity of the target terrain. The airburst over average type of soil ranges from 4 to 20 feet dependent on the angle of approach. When firing at quadrants of elevation over 65 degrees (1,155 mils), the height of burst is less than 9 feet. Burst height increases as angle of approach decreases. Light tree foliage and light vegetation affect the height of burst only slightly but dense tree foliage and dense vegetation will increase the height of burst. Target terrains such as ice and dry sand give lowest burst heights and water and wet ground give highest burst heights.

*g. Crest Clearance.* Close approach to crests, trees, towers, large buildings, parked aircraft, mechanized equipment, and similar irregularities will cause functioning at heights greater than over average level terrain. When targets are beyond such irregularities, clearance of at least 100 feet should be allowed to assure maximum effect over the target area.

*h. Malfunctions.* At the present stage of development a minimum of 85 percent of the fuzes will function normally on proximity approach to, or impact with, a suitable target under conditions of normal use. Less than 15 percent of the fuzes may be expected to malfunction. These malfunctions may be divided into early burst and duds as described in (1) and (2) below.

- (1) *Early burst.* An early burst is a spontaneous functioning of an armed proximity fuze at some time after arming has been completed but prior to proximity approach to the target. An early burst is not related to a premature, which is a detonation of a fuzed projectile before the fuze is completely armed.
- (2) *Dud.* A dud is a projectile that has

failed to explode due to a failure of the fuze to fire.

*i. Climatic Effects.* The fuze may be used for day or night operations with equal effect. The fuze will function normally in light rain. However, heavy rain, sleet, or snow will cause an increase in the number of early bursts. At extremes of temperatures (below  $-25^{\circ}$  and above  $+125^{\circ}$  F.), it is not abnormal to experience an increase in malfunctions proportional to the severity of the environmental conditions.

*j. Preparation for Firing.* No setting is required. Any attempt to set the fuze will result in a malfunction. Care should be taken to assure a tight assembly of the fuze, washer, and projectile. The wavy spring washer should be completely compressed and no air gap exist between fuze and projectile.

*k. Precautions in Firing.*

(1) When firing, the safety precautions prescribed in AR 385-63 and in TM 9-1903 for the firing of artillery ammunition with HE loaded shell should be followed.

**WARNING: When firing in mortar M1 the use of more than five increments is prohibited.**

(2) Do not remove safety devices from fuzes until just before use.

(3) Before loading into weapon, ammunition should be free of sand, mud, moisture, frost, snow, ice, grease, or other foreign matter.

(4) Exercise care when handling or loading to avoid striking the fuze or primer against the muzzle of the weapon.

(5) Upon firing a cartridge, the loader must instantly withdraw hands, head, and upper part of the body from the

muzzle in order to avoid the blast which occurs when the cartridge is discharged.

**WARNING: Proximity fuzed short rounds which are duds contain a complete explosive train and impact element and should not be approached or disturbed for at least 30 minutes. After the 30-minute waiting period, the dud is still dangerous but may be approached carefully for destruction in place. If it is impossible to destroy in place, the dud should be removed carefully for subsequent destruction by qualified disposal personnel. If the situation permits a longer waiting period, 40 hours should be allowed prior to approaching the dud for destruction in place or for removal. It must be remembered that the dud is still dangerous after this 40-hour waiting period.**

(6) Proximity fuzes may malfunction under the influence of nearby bursts or fragments. An abnormal number of malfunctions may be experienced from volley, salvo, or rapid fire from adjacent mortars. This type of malfunction may be corrected by increasing the spacing of mortars or increasing the time between the rounds fired in volley, salvo, or rapid fire.

(7) Proximity fuzes will be used in accordance with limitations listed on data cards.

(8) Misfires will be handled as indicated in AR 385-63.

#### 59. Fuze, Proximity, Practice: M517 (T178E3)

This fuze is similar to the proximity fuze M517 (T178E3) described in paragraph 58. The fuze is issued to troops for target-practice firing.

## Section II. PROPELLING CHARGES

### 60. General

*a. Propellant.* Propellant for use with mortar ammunition is manufactured in the form of square propellant sheets or flake form. For 60-mm and 81-mm mortar ammunition (except the high-explosive cartridge M362),

the sheets are sewed together and are made up into bundles to predetermined weight and are sealed in cellophane envelopes (fig. 49). Propellant for the high-explosive cartridge M362 and the smoke cartridge M370, in flake form, is contained in a stitched urea-formaldehyde

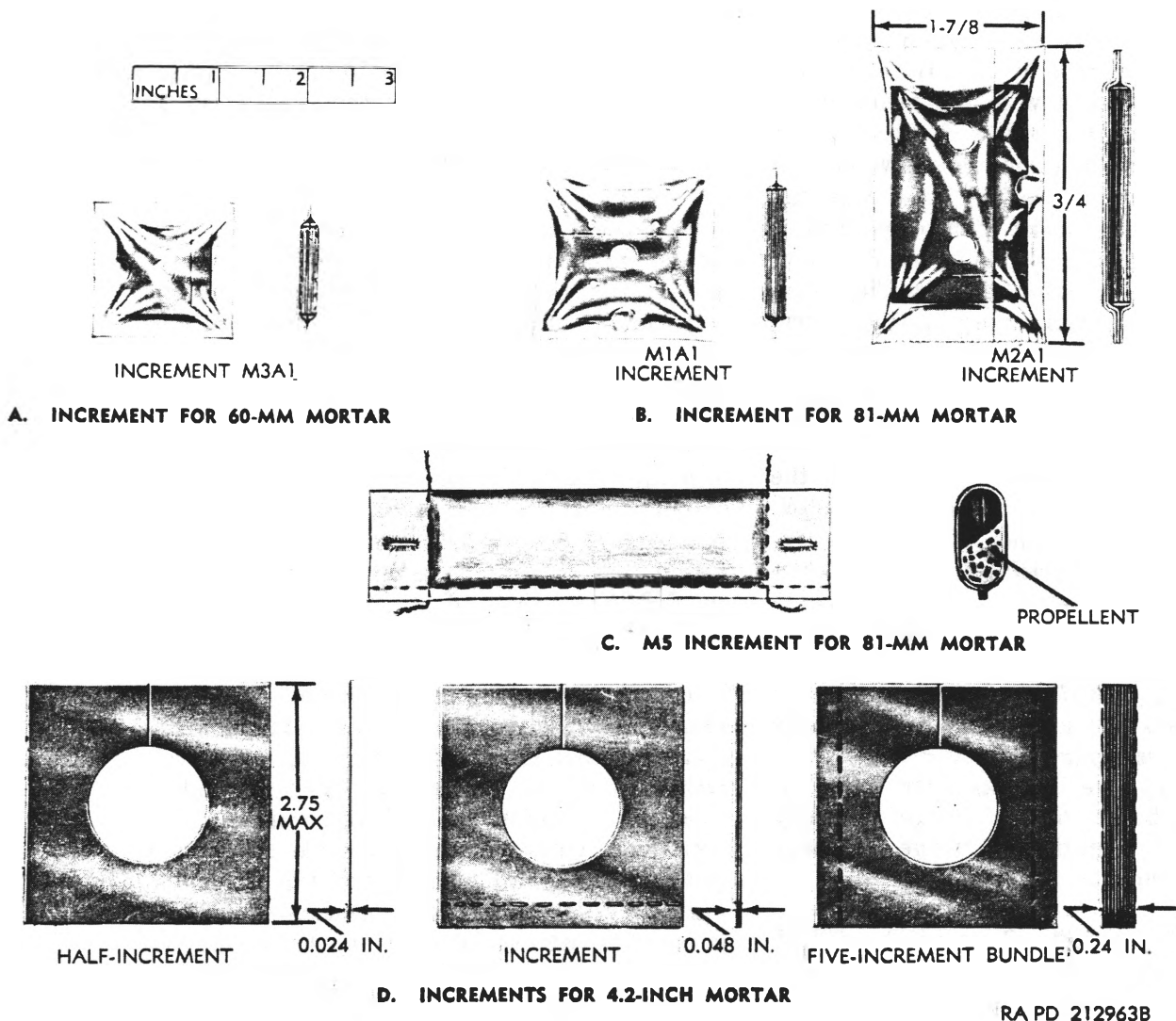

Figure 49. Increments for 60-mm, 81-mm, and 4.2-inch mortar cartridges.

and melamine-resin treated cotton cloth bag. Propellant for the 4.2-inch mortar is made up of square propellant sheets. A single sheet is called a "half increment"; two single sheets sewed together are called an "increment." Five increments (10 half increments) sewed together are called a "five-increment bundle" (fig. 49). The increments are manufactured in such a manner that they are accessible for adjustment prior to firing. See TM 9-1900 and TM 9-1910 for propellant compositions and forms of grains and increments.

*b. Determination of Propellant Weight.*

The weight of propellant which is loaded into each charge is fixed. Each charge is checkweighed to keep weight within narrow tolerance requirements. To assure that the quality of the propellant is uniform, each lot must meet density, grain diameter, and grain thickness requirements. In addition, the propellant must meet specific uniform velocity and pressure requirements when fired in the mortar.

*c. Identification.* Propelling charges for mortars may be identified by the markings on the container or by the type of increments (fig. 49).

d. *Mortar Propelling Charges.* The propelling charge for mortar ammunition is considered "semifixed," since it is adjustable and loaded into the weapon with the projectile in one operation. The propelling charge consists of an ignition cartridge and of removable half or full increments, to provide for charge firing. The increments consist of stitched pads of sheet propellant having a hole in the center of each increment or stitched paraffin wax-treated cotton cloth bags containing flake form propellant. In present practice, each increment for the 60-mm and 81-mm mortars (except for the high-explosive cartridge M362 and smoke cartridge M370) is sealed in a cellophane bag and "A1" is added to the model designation of the increment; for example, M1A1, M2A1, and M3A1. One increment is fitted into each of the spaces between the blades of the fin; or the increments may fit around the "boom" just ahead of the fins (increment charge M5 for 81-mm cartridges M362 and M370). Increments for the 4.2-inch mortars are not sealed in cellophane and fit on the cartridge container at the rear of the projectile. The ignition cartridge is inserted into the hollow base of the fin assembly shaft or into the ignition cartridge container ahead of the primer.

#### 61. Propelling Charge for 60-mm Mortar Cannon

This charge consists of the ignition cartridge M5A1 and four propellant increments M3A1 except that the propelling charge for the training projectile M69 consists of ignition cartridge M5A1 with percussion primer M32 or of ignition cartridge M4. The ignition cartridge M5A1 fits into the hollow fin assembly shaft. The four removable increments are held in place between the fin blades by the increment holder M1A1. The propellant increment charge M3A1 is formed by stitching together 1-inch square, 0.004-inch thick sheet propellant. The sheets are made of double-base propellant M8 and have a center perforation. The number of thicknesses of sheet propellant is determined by the weight of the increment needed. Each increment is sealed individually in a cellophane bag. The nominal weight of four increments (full charge) is about 160 grains. The four removable in-

crements and ignition cartridge provide for fire adjustment (charge firing). The ignition cartridge alone serves as the propelling charge for extremely short ranges (charge 0).

#### 62. Propelling Charges for 81-mm Mortar Cannon

Dependent upon type and model of cartridge, either propellant increment charge M1A1, propellant increment charge M2A1, or propellant increment charge M5 is used with 81-mm mortar ammunition. Six propellant increment charges M1A1, four propellant increment charges M2A1, or eight propellant increment charges M5 are provided for fire adjustment (charge firing). Dependent upon types and model of cartridge, ignition cartridge M3, M6, M8, or M66 is used with 81mm mortar ammunition. The propellant increment charge M1A1 or M2A1 consists of a stitched bundle of 0.008-inch thick, perforated sheet propellant double-base composition M8 and is enclosed in a cellophane bag. The propellant increment charge M5 consists of a stitched paraffin wax-treated cotton cloth bag containing 0.012-inch web formulation propellant M9 in "flake" form. The weights of the full propellant increment charges are as follows: the M1A1-700 grains; M2A1-820 grains; and the M5-1,304 grains. The propellant increment charge M1A1 is inserted between adjacent blades of the fin assembly and is held in place by the increment holder M2A1. The propellant increment charge M2A1 is held in place forward of the fins by the increment holder M3. The propellant increment charge M5 is held to the boom of the fin assembly by forward and rear increment holders. Increments of all types are removable as required for fire adjustment (charge firing). The ignition cartridge alone serves as the propelling charge for extremely short ranges (Charge 0).

*Note.* A warning label is placed on the HE cartridge M362 indicating that when this cartridge is fired in the 81-mm mortar M1 not more than 5 increments may be used. A warning label is placed on the smoke (WP) cartridge M370 indicating that when this cartridge is fired in the 81-mm mortar M1 not more than six increments may be used.

#### 63. Propelling Charge for 4.2-Inch Mortar Cannon

Two types of propelling charge are used

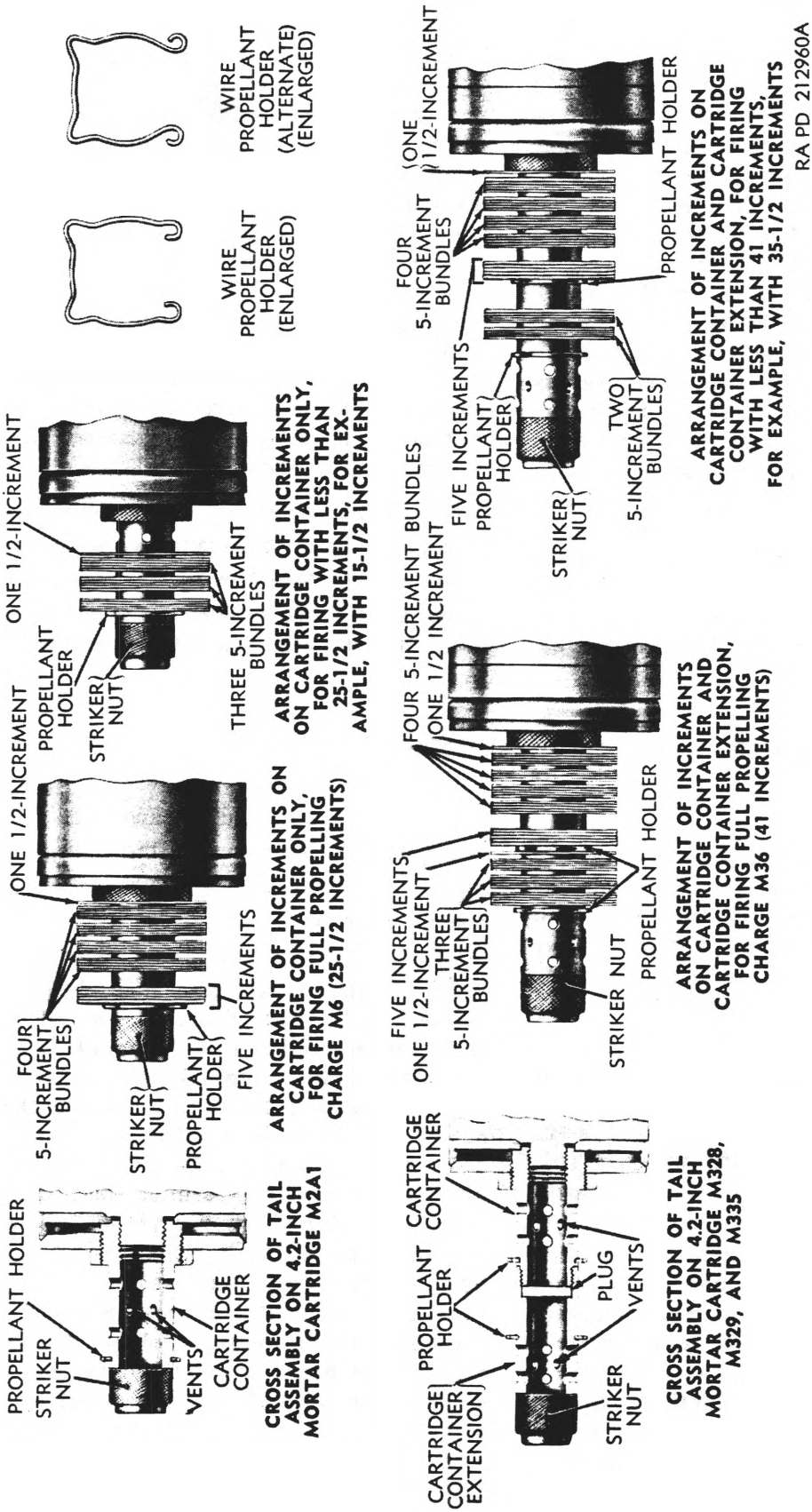

Figure 50. Tail assemblies and arrangement of propelling charges on tail assemblies of 4.2-inch mortar cartridges.

with 4.2-inch mortar cannon.

a. The propellant increment charge M6 is used with the high-explosive cartridge M3 series and the smoke or gas cartridge M2 series. The propellant increment charge consists of 25½ increments of double-base sheet propellant (full charge), packed as half-increments and 5-increment bundles. The one-half increment is a 2.75-inch square of sheet propellant of 0.024-inch thickness having a 1.35-inch diameter perforation in the center and a radial cut through one side of the sheet along the centerline of the 1.35-inch circular hole perpendicular to the side. Two ½ increments sewed together form an increment and 5 increments (10 one-half increments) sewed together form a 5-increment bundle. The propellant increment charge M6 is comprised of four increment bundles 5 increments and one 1/2 increment (total of 25-1/2 increments) and is in place on the ignition cartridge container of the cartridge as shipped. Increments not required for firing in a par-

ticular zone are removed and discarded. Refer to paragraphs 64 through 74 and figure 50.

b. The propelling charge M36 is used with the high-explosive cartridge M329, the illuminating cartridge M335, and the smoke cartridge M328. The propelling charge consists of 41 increments, made up of seven 5-increment bundles, 5 increments and two ½ increments (total 41 increments), all of which are similar to the increments of the propellant increment charge M6. In order to accommodate the large charge (41 increments), cartridges using the propelling charge M36 have an ignition cartridge container extension assembled to the cartridge container. Increments not required for fire adjustment (charge firing) are removed and discarded. See figure 44.

**CAUTION:** When the high-explosive cartridge M329, the illuminating cartridge M335, and the smoke cartridge M328 are fired in the 4.2-inch mortar M30 with the 25-1/2 increments or less, the cartridge container extension must be removed.

### Section III. IGNITION CARTRIDGES AND PRIMERS

#### 64. General

a. *General Discussion.* A primer is used in a propelling charge explosive train as the component which initiates burning of the propelling charge by a flame. Such primers vary in size and complexity, depending upon their type and the quantity of propelling charge to be ignited.

b. *Classification.* Primers are classified by method of initiation. The primers used with mortar ammunition are initiated by a sharp blow from a firing pin in the weapon. This type of primer is considered a "percussion-type" primer.

c. *Percussion Primers Used in Mortar Ammunition.* The percussion primer screws into the base of the fin assembly of mortar ammunition and is relatively short and squat. It consists of a head, into which is assembled a firing plug, and a housing containing a percussion element pressed into one end and a hollow black powder pellet assembled into the other end. The housing is crimped into the

head and a paper disk shellacked to the exposed end of the housing holds the pellet in place. An ignition cartridge, essentially a heavy, paper-walled, waxed, cylindrical container, holding a propelling charge, is assembled into the fin assembly ahead of the primer. The primer functions as follows: As the round slides down the barrel of the mortar tube, the firing plug of the primer strikes sharply against a fixed firing pin in the base of the mortar tube and initiates the percussion element assembly. The blast from the exploding primer mixture ignites the black powder pellet and carries on into the end of the ignition cartridge. This blast, amplified by the flames from the burning pellet, ignites the small propellant charge in the ignition cartridge which, in turn, blows out through radial flash holes in the fin body or the cartridge container to ignite the propellant increment charges attached to the outside of the fin assembly or the cartridge container. Refer to table V.

Table V. Primer and Ignition Cartridge Data

Designation and model No.	Length (in.)	Diameter (in.)		Charge	Weight (grains)	Caliber of mortar cannon ammunition with which used
		Head	Body			
CARTRIDGE, IGNITION: M2 (shotgun cartridge type).	2.43	0.889	0.808	120.0	---	4.2-inch
CARTRIDGE, IGNITION: M3 shotgun cartridge type).	2.64	0.889	0.795	120.0	---	81-mm
CARTRIDGE, IGNITION: M4 (shotgun cartridge type.	1.75	0.728	0.655	47.0	---	60-mm
CARTRIDGE, IGNITION: M5A1.	1.43	---	0.655	40.0	82.2	60-mm
CARTRIDGE, IGNITION: M6	2.23	---	0.795	120.0	190.0	81-mm
CARTRIDGE, IGNITION: M8	2.03	---	0.795	120.0	185.0	81-mm
CARTRIDGE, IGNITION: M66	2.10	---	0.795	115.0	280.0	81-mm
PRIMER, PERCUSSION: M82	0.516	0.82	0.47	1.65	344.8	60-mm
PRIMER, PERCUSSION: M84	0.761	1.00	0.56	1.65	737.4	81-mm
PRIMER, PERCUSSION: M71	1.35	0.78	0.54	3.49	280.0	81-mm

*d. Packing and Shipping Data.* Packing and shipping data appear in SM's 9-5-1310, 9-5-1315, and 9-5-1390.

#### **65. Cartridge, Ignition: M2**

This ignition cartridge, which contains both the primer and the ignition charge, is used with the 4.2-inch mortar ammunition. It essentially is a blank-loaded shotgun cartridge containing a charge of 120 grains of propellant powder.

#### **66. Cartridge, Ignition: M3**

This ignition cartridge is issued for use only with the 81-mm training projectile M68. It contains both the primer and the propelling charge. The body assembly design essentially is that of a shotgun cartridge, made of commercial cartridge paper, having a brass base with the paper body bulged outward just forward of the metal base. A commercial percussion primer is pressed into the brass base; a propelling charge is loaded into the body, followed by a chipboard disk, a lead disk, and an outer disk of chipboard and bond paper. The disks are secured by crimping the open end of the paper body inward, after which the entire assembly is dipped in molten paraffin. The bridge in the body is utilized for holding the assembly in the fin assembly of the round. The propelling charge is 120 grains of propellant powder M9. See figure 12.

#### **67. Cartridge, Ignition: M4**

This ignition cartridge is issued for use with the 60-mm mortar training projectile M69 only. It is identical in design with the ignition cartridge M3 (par. 66), except that it is smaller and has a 47-grain charge of propellant powder. See figure 6.

#### **68. Cartridge, Ignition: M5A1**

This ignition cartridge (fig. 51) essentially is a cylindrical paper container for a propelling charge which must be used in conjunction with the percussion primer M32 (par. 72) in 60-mm mortar ammunition. The body of the ignition cartridge consists of an outer tube and a shorter inner tube both made from layers of paraffined cartridge paper. A chipboard washer, with a paper tube cemented into a center hole, and thin paper disks cemented

to one face of the washer and over the other end of the tube, is assembled into one end of the body with the small tube extending into the body. The outer tube of the body is crimped inward to secure the washer and tube assembly in place. A charge of propellant powder M9 is loaded into the body and a chipboard closing disk is crimped into the remaining open end of the body. The half of the body containing the washer and tube closure is colored red, while the remaining half with the chipboard disk is colored yellow, to facilitate inspection during and after assembly into the fin of the round. The red end must be assembled adjacent to the primer.

#### **69. Cartridge, Ignition: M6**

This ignition cartridge essentially is a cylindrical paper container for a propelling charge which must be used in conjunction with the percussion primer M34, (par. 73). Its construction is similar to that of the ignition cartridge M5A1 (par. 68), except that the end closures consist of heavy chipboard washers with a thin paper disk cemented to one face, the faces being assembled adjacent to the propellant powder M9.

#### **70. Cartridge, Ignition: M8**

This ignition cartridge (fig. 51) is used in conjunction with the percussion primer M34 (par. 73) and is identical with the ignition cartridge M6 (par. 69), except that it is 0.20 inch shorter.

#### **71. Cartridge, Ignition: M66**

This ignition cartridge, used in conjunction with the percussion primer M71 (par. 74), is similar to the ignition cartridge M5A1 (par. 68). The ignition cartridge body is formed from standard commercial paraffined cartridge paper with the outer layer colored half red and half yellow and an inner layer of two 0.005-inch thick brass liners to increase the confinement. The propelling charge is 115 grains of propellant powder M9. The ignition cartridge is placed in the cartridge housing with the red end towards the primer or rear of the round. This arrangement is necessary because the red colored portion of the cartridge contains a paper flash tube which extends approximately half the length of the

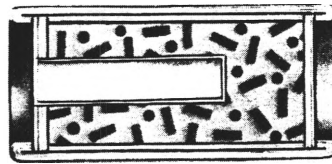
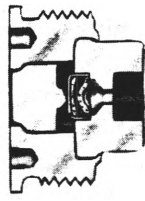
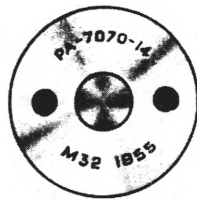

PRIMER, PERCUSSION: M32

CARTRIDGE, IGNITION: M5A1

**FOR 60 MILLIMETER**

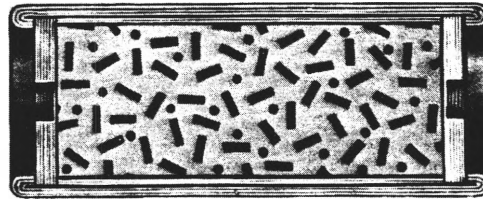
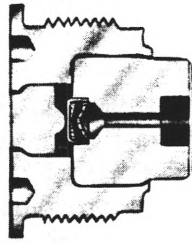
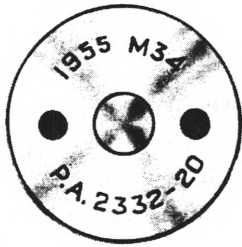

PRIMER, PERCUSSION: M34

CARTRIDGE, IGNITION: M8

**FOR 81 MILLIMETER**

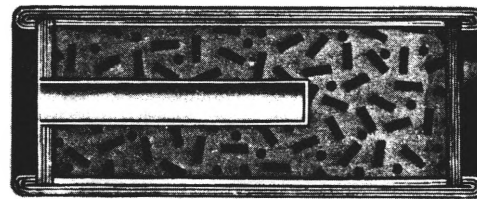
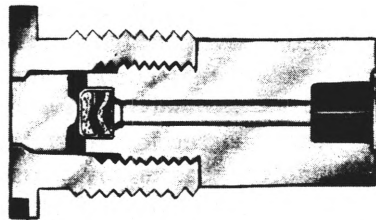
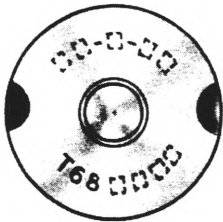

PRIMER, PERCUSSION: M71

CARTRIDGE, IGNITION: M66

**FOR 81 MILLIMETER**

ORD A17

*Figure 51. Primers and ignition cartridges for use with 60-mm and 80-mm mortar ammunition.*

cartridge body. The purpose of the paper flash tube is to permit the flame from the primer to ignite the ignition cartridge charge down to its center, thereby producing better and more uniform ignition.

**72. Primer, Percussion: M32**

This percussion primer (fig. 51), for use

with 60-mm cartridges, is of the standard design of mortar ammunition primers (par. 64c). The head and housing are made of either steel or brass.

**73. Primer, Percussion: M34**

This percussion primer (fig. 51), for use with 81-mm cartridges, is of the standard de-

sign of mortar ammunition primers (par. 64c). It differs from the percussion primer M32 only in that the head and housing are larger in size; the loading is identical.

#### 74. Primer, Percussion: M71 or M71E1

This percussion primer is similar to the percussion primers M32 and M34, except for the exterior shape which facilitates assembling into the hub of the fin of the high-explosive cartridge M362 or M362A1 and smoke car-

tridge M370. The following parts make up the complete assembly: the head and body made from aluminum alloy, the firing plug made from aluminum alloy, the closing disk made from gilding metal, the pellet consisting of 3.12 grains of Grade A5 black powder, and the primer assembly M35 which contains 0.37 grains of primer mixture. The primer is required to function under the impact of a 2.95-pound weight dropped from a height of 11¼ inches on the firing pin.

### Section IV. BOOSTERS, BURSTERS, SUPPLEMENTARY CHARGES, ADAPTERS, AND CLOSING PLUGS

#### 75. Boosters

Since the bursting charges of high-explosive projectiles are relatively insensitive to shock, a comparatively large detonating charge is necessary to insure a high-order detonation of the bursting charge. The use of more sensitive explosives, such as mercury fulminate or lead azide, in the quantities required for the purpose would create excessive hazards in handling and firing. Therefore, such explosives are used only in small amounts as initiating and intermediate detonating charges. A separate charge of somewhat less sensitivity (usually tetryl) is provided for detonating the high-explosive charge of the projectile; because its function is to increase or "boost" the effectiveness of the explosive train, this charge is known as a booster charge. The booster charge may be incorporated in the fuze itself or may be encased in a thin casing of metal or plastic which is screwed permanently to the fuze and handled as a unit with the fuze. The assembled casing with booster charge is known as a booster. Most types are provided with a boresafety mechanism; these boosters usually contain one or more charges in addition to the booster charge, such as an intermediate detonator and/or a lead charge. Types in use are described in this section.

#### 76. Booster: M21A4

*Note.* The key letters shown in parentheses in *a* and *b* below refer to figure 52.

*a. General.* The booster M21A4 (fig. 52)

is an integral part of FUZE, POINT DETONATING: M51A5 and FUZE, MECHANICAL TIME AND SUPERQUICK: M500A1 (or M500). The booster is provided with a boresafety mechanism to prevent accidental functioning in the weapon. The booster has a centrifugally actuated pin (J) which acts as a safety measure to prevent the rotor from moving out of its unarmed position prior to assembling the fuze with booster to the projectile.

*b. Description.* The booster consists of two major parts: a booster cup (M), which contains a tetryl booster charge (N) and screws onto a threaded brass body (A) containing tetryl booster lead (L), and a rotor assembly. The rotor assembly consists of a rotor (F) containing a lead azide-tetryl flash-initiated detonator (E), a centrifugally actuated pin (J), a centrifugal pin lockpin (P) which operates under setback, a rotor stop pin (D), a rotor lockpin (G), and a rotor lockpin lock (H). The rotor is seated on its pivot pin (K) so that the detonator normally is out of alignment with other explosive elements in the booster and the assembled fuze. The center of gravity of the rotor assembly is off the centerline of the pivot center so that the assembly will rotate under centrifugal force. The rotor is locked in the unarmed position prior to firing by the spring-held centrifugal pin. The centrifugal pin, in turn, is held in the locking position by the centrifugal pin lockpin. The function of the rotor stop pin is to stop the rotor assembly when it has ro-

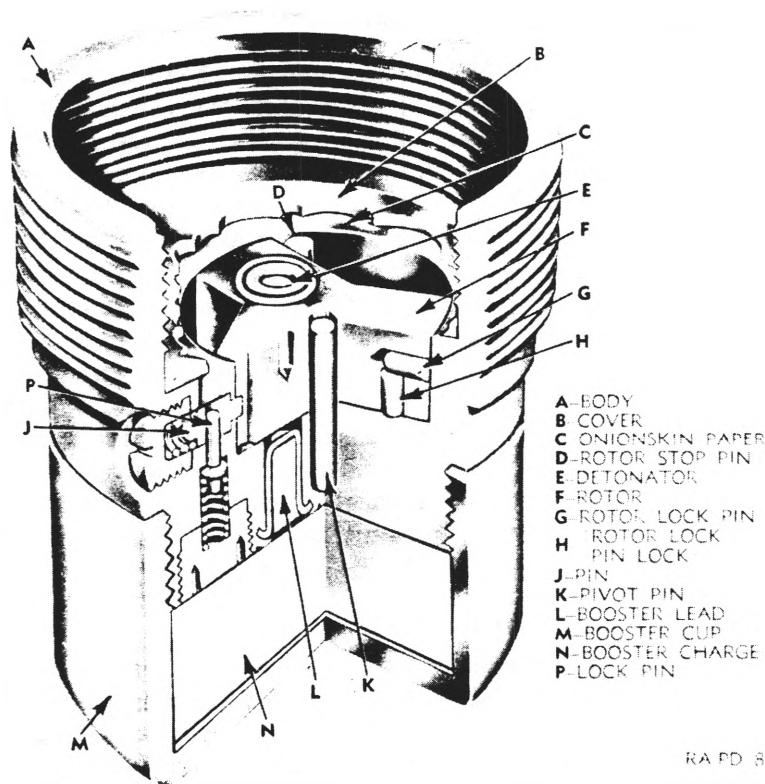

- A-BODY
- B COVER
- C ONIONSKIN PAPER
- D-ROTOR STOP PIN
- E-DETONATOR
- F-ROTOR
- G ROTOR LOCK PIN
- H ROTOR LOCK PIN LOCK
- J-PIN
- K-PIVOT PIN
- L-BOOSTER LEAD
- M-BOOSTER CUP
- N-BOOSTER CHARGE
- P-LOCK PIN

RA PD 80886F

Figure 52. Booster: M21A4.

tated to alined or armed position. The bore-safety mechanism is covered at the forward end of the booster by a thin brass cover (B) which has a flash hole to permit transmission of the fuze action to the detonator in the rotor of the booster. The flash hole is covered by a thin disk of onionskin paper (C) to prevent foreign matter from entering the booster.

*c. Functioning.* Upon firing, setback forces the centrifugal pin lockpin rearward against its spring, freeing the centrifugal pin. Centrifugal force moves the forward end of the lockpin under the shoulder in the lockpin cavity. This prevents the lockpin from returning to its original position. When the projectile reaches the required rotational velocity, the centrifugal pin moves outward against its spring. This releases the rotor which then rotates to the alined or armed position against the stop pin, whereupon the rotor lockpin moves radially outward under centrifugal force from its cavity in the rotor partially

and into the hole in the booster body. Creep force causes the rotor lockpin lock to move axially forward into the space behind the rotor lockpin, preventing the rotor lockpin from returning to its original position. Thus, the booster is locked in the armed position throughout the flight of the projectile. Action of the booster detonator is initiated by the detonating elements, or magazine charge (in time fuzes), of the fuze. Explosion of this detonator is transmitted through the booster lead to the booster charge. The booster charge, in turn, detonates the high-explosive charge of the projectile.

*d. Preparation for Firing.* For firing the booster M21A4, the safety (cutter) pin if present must be removed before assembling the fuze and booster to the projectile, otherwise no preparation is required.

#### 77. Booster: M124 (T35E7)

The booster M124 (T35E7) is an integral part of FUZE, POINT DETONATING: M535

T177E3) (fig. 43), being screwed into the base of the fuze body. The booster is provided with a boresafety mechanism to prevent accidental functioning in the weapon. The booster detonator is turned and locked in an "out-of-line" position by means of a ball-rotor mechanism, which is held in the boresafe position by setback force. The four detents which lock the ball rotor move outward under centrifugal force as soon as the projectile begins to rotate, thereby freeing the ball rotor. The rotor does not move immediately, since it is held against the spherical seat in the booster body by its own inertial resistance to the acceleration of the projectile. When the projectile begins to decelerate, the ball rotor begins to proceed toward the "in-line" or "armed" position. As the ball rotor arms, the counter-bore forward of the detonator cavity, drops over the annular projection of the flash hole entrance of the rotor retainer. The inertial weight of the ball rotor brought to bear by the deceleration of the projectile serves to hold the rotor in this position. The booster is then armed and will function on receipt of a flash from either the superquick detonator or the delay element of the fuze.

#### 78. Booster: M125

This booster is a newer type which is being used to renovate the M500 series fuzes by replacing the older-type booster M21A4. The renovated fuze is known as FUZE, POINT DETONATING: M520. (Refer to par. 39d.)

#### 79. Bursters

In chemical projectiles, the function of the explosive charge is to burst the projectile casing and disperse the chemical filler. Hence, when used in chemical projectiles, the charges generally are known as burster charges and the assembly as a burster. The burster, like the booster charge for high-explosive projectiles, consists essentially of a high-explosive charge in a suitable thin-walled container. Some early designs were similar to boosters, but modern types consist of a long tube assembly extending into the projectile cavity. This insures a rupture of the projectile and effective dispersion of the chemical filler.

#### 80. Burster: M1

This burster is used in the burster casing M2 in the 81-mm mortar chemical projectile M57 series. The burster M1 consists of approximately 275.5 grains of tetryl pellets loaded under pressure in an aluminum-alloy tubing 0.39 inch in diameter and 9.82 inches long. The burster casing M2 is made up of a seamless steel tubing with internal dimensions approximately the same as the external measurements of the burster, seated at the forward end in a steel sleeve. The assembly is constructed so that it is a press-fit in the adapter of the projectile, and extends approximately three-quarters of the length of the projectile cavity. Action of the burster is initiated by the fuze, which has a booster charge assembled therein.

#### 81. Burster: M19

This burster is used in the burster casing M8 in the 60-mm mortar smoke projectiles. It extends approximately three-quarters the length of the projectile cavity. The burster consists of approximately 165 grains of tetryl pellets loaded under pressure in an aluminum-alloy tube 0.38 inch in diameter and 3.9 inches long. One type of burster casing M8 is made of steel tubing 0.57 inch in diameter and 4.1 inches long. This is fitted with a steel sleeve to form the burster casing assembly. Another type of burster casing M8 is made in one piece from a deep-drawn stamping of steel. The burster is press-fitted in the adapter of the projectile. Action of the burster is initiated by the point detonating fuze.

#### 82. Burster: T74

This burster in conjunction with the burster initiator T7 is used in the burster casing T31 in the chemical projectile M328 for 4.2-inch mortars. The burster T74 consists of 1,478 grains of cast tetrytol (70-percent tetryl and 30-percent trinitrotoluol) in a steel tube 0.676 inch in diameter and 11.935 inches long. The minimum inside length of the burster casing is 13.733 inches. The burster casing is press-fitted in the adapter of the projectile and extends the full length of the projectile cavity.

#### 83. Supplementary Charge

a. This charge (fig. 53), assembled in

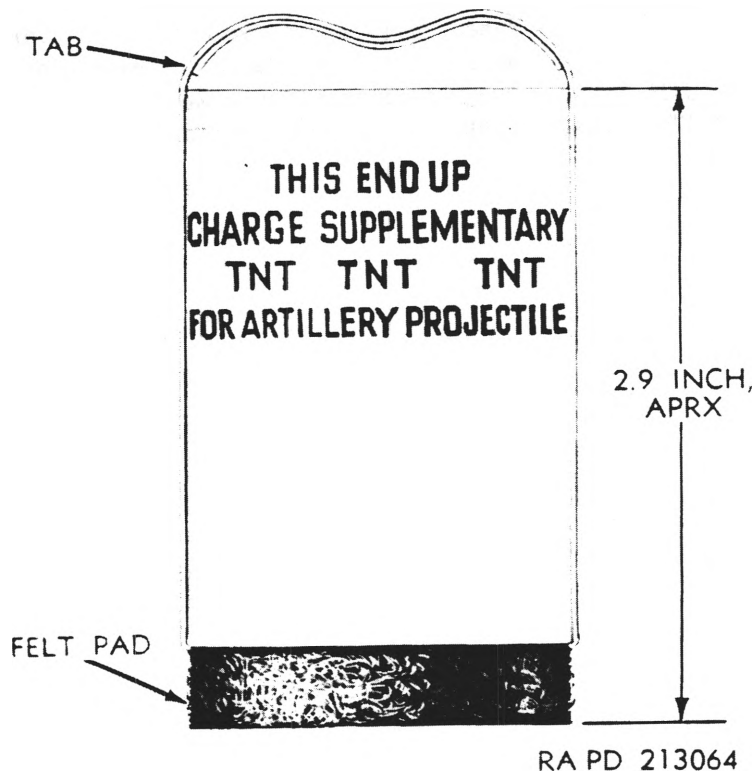

Figure 53. Supplementary charge.

deep-cavity projectiles, consists of a cylindrical aluminum container filled with 0.30 pound of TNT. A 3/8-inch thick felt pad is cemented to the rear end of the container to cushion the charge when the fuze is inserted and to protect it from the shock of setback. A loop (tab) of adhesive tape is attached to the forward end to facilitate the withdrawal of the supplementary charge from the projectile. The overall length of the charge is approximately 2.9 inches and the diameter is approximately 1.8 inches.

b. The supplementary charge is placed in deep-cavity projectiles with the felt pad toward the base of the projectile and with the loop of adhesive tape in such a position that it may be grasped to lift the charge out of the cavity. Subsequent assembly of time or impact fuze (plus its booster) to the projectile will compress the felt pad slightly and thus hold the charge securely in the cavity.

#### 84. Adapters

The openings in the nose of projectiles are threaded to conform to the requirements of the fuzes or fuze with booster combinations. With this and the greater standardization of fuze threading, interchangeability is obtained without modification. However, some mortar projectiles may require fuzes containing a greater explosive charge, therefore the point detonating fuze M526A1 has an adapter which provides for the appropriate booster. Chemical projectiles have adapters to provide means of seating a burster casing.

#### 85. Closing Plugs

In unfuzed projectiles, normally packed in individual sealed containers, a closing plug protects against the entrance of foreign matter into the fuze hole during shipment, storage, and handling. Closing plugs are threaded and have heads suitable for prescribed pack-

ing containers and for wrenches to assemble or remove them from the projectile. The aluminum-alloy or plastic closing plugs used with 4.2-inch ammunition have 2-12NS-1 threads, are 2.12 inches long and 2.472 inches

in diameter, and weigh 0.39 pound. In unfuzed deep-cavity projectiles, a carbon steel sheet insert is placed between the supplementary charge and closing plug to keep the supplementary charge from movement.

## CHAPTER 4

### MORTAR AMMUNITION FOR SUBCALIBER EQUIPMENT

---

#### 86. General

The most efficient and direct method of teaching conduct of fire is by firing combat ammunition under field conditions. However, ammunition training allowances and range limitations often restrict such training to sub-caliber firing on reduced or miniature ranges. Therefore, subcaliber equipment M31 has been manufactured for use in the 4.2-inch mortar M30.

#### 87. Supcaliber Equipment M31

The subcaliber equipment M31 for use in the 4.2-inch mortar M30 consists of a 60-mm barrel M2 or M19 with two aluminum adapter rings, a filler block, and a rod (filler block retriever). The aluminum adapter rings prevent the rifling of the 4.2-inch barrel from being scored and also provide for a snug fit of the 60-mm mortar barrel in the 4.2-inch barrel. The filler block consists of a round hardwood block fitted with two brass rings around it and a steel shock cap on the upper end. The brass rings prevent the block from splitting and allow the block to fit in the barrel without scoring the barrel. The steel shock cap receives the spherical projection of the 60-mm barrel and distributes the recoil shock

evenly over the end of the filler block. The center of the filler block cap is threaded to receive the rod (filler block retriever). The lower end of the filler block is drilled so that it fits over the striker pin of the 4.2-inch barrel, allowing all the shock to be exerted on the base end of the 4.2-inch barrel rather than on the striker pin. The rod (filler block retriever) is used to remove the block from the 4.2-inch mortar barrel. The rod is made of steel with a handle on one end. The other end is threaded so that it may be screwed into the shock cap of the filler block. When the subcaliber equipment M31 is in place in the 4.2-inch mortar barrel, the muzzle of the 60-mm mortar protrudes 1½ inches from the muzzle of the 4.2-inch mortar.

#### 88. Ammunition for Subcaliber Equipment

Any type of 60-mm mortar cannon ammunition, including high-explosive, illuminating, practice, smoke, or training projectiles may be fired from the subcaliber equipment. The training projectile is fired usually on a training projectile range, whereas the other projectiles are fired on a normal field firing range. See paragraphs 13 through 17 for detailed information on 60-mm mortar cannon ammunition.

## CHAPTER 5

### DESTRUCTION OF AMMUNITION TO PREVENT ENEMY USE

#### 89. General

a. Destruction of ammunition described herein, when subject to capture or abandonment, will be undertaken by the using arm only when, in the judgment of the unit commander concerned, such action is necessary in accordance with orders of, or policy established by, the Army commander.

b. The information which follows is for guidance only. The conditions under which destruction will be effected are command decisions and may vary in each case, dependent upon a number of factors such as the tactical situation, security classification of the ammunition (AR 380-5), quantity and location of ammunition, facilities for accomplishing destruction, and time. In general, destruction of ammunition can be accomplished most effectively by burning or detonation, or a combination of these. Selection of the particular method of destruction requires imagination and resourcefulness in utilization of the facilities at hand under the existing conditions. Time is usually critical.

c. If destruction to prevent enemy use is resorted to, ammunition and its components must be damaged so badly that they cannot be restored to a usable condition in the combat zone. Equally important, the same essential components of all ammunition must be destroyed so that the enemy cannot assemble complete rounds from undamaged components.

d. If destruction of ammunition is directed, due consideration should be given to:

- (1) Accomplishment of the destruction in such a manner as to cause the greatest obstruction to enemy movement and also prevent hazard to friendly troops from fragments.
- (2) Observance of appropriate safety precautions.

#### 90. Methods

Ammunition can be destroyed most quickly

by burning or detonation. The following methods, in order of preference, are considered the most satisfactory for destruction of ammunition to prevent enemy use.

a. *Unpacked Ammunition.*

- (1) *Method No. 1-by burning.* Stack ammunition in small piles. Stack or pile most of the available gasoline in cans and drums around the ammunition. Throw onto the pile all available flammable materials such as rags, scrap wood, and brush. Pour gasoline over the pile. Use enough flammable material to insure an extremely hot fire. Ignite the gasoline by means of an incendiary grenade fired from a safe distance, a burst from a flame thrower, a combustible train of suitable length, or other appropriate means.

**CAUTION: Take cover immediately. Due consideration should be given to the highly flammable nature of gasoline and its vapor. Carelessness in its use may result in painful burns. The danger zone is approximately 500 yards.**

- (2) *Method No. 2-by demolition.* High-explosive cartridges can be destroyed by sympathetic detonation with demolition charges using 1-pound TNT blocks or equivalent together with the necessary detonating cord to make up each charge.
  - (a) Stack the ammunition in two stacks, 15 cartridges each, about 3 inches apart, with the fuzes in each stack toward each other. Place the charges between the stacks, using a minimum of 2 pounds of TNT for every 10 rounds of ammunition.
  - (b) Connect all the charges for simultaneous detonation with detonating cord.
  - (c) Provide for dual priming to minimize the possibility of a misfire.

(d) Detonate the charges. For complete details on the use of demolition materials and methods of priming and detonating demolition charges, refer to FM 5-25. Training and careful planning are essential. The danger area is approximately 500 yards.

b. *Packed Ammunition.*

(1) *Method No. 1-by burning.* Stack the packed ammunition in small stacks. Cover with all available flammable materials such as rags, scrap wood, brush, and gasoline in drums or cans. Pour gasoline over the pile. See a (1) above for means of igniting and precautions.

(2) *Method No. 2-by demolition.*

(a) The destruction of packed ammu-

nition by sympathetic detonation with TNT demolition charges is not advocated for use in forward combat zones. Satisfactory destruction involves placing the TNT demolition charges in alternate packs of ammunition, which is a time-consuming job.

(b) In rear areas or fixed installations, sympathetic detonation may be used to destroy large ammunition supplies when destruction by burning is not feasible. See a (2) above for information concerning the destruction of ammunition by demolition.

### 91. Priority

Priority for destruction of ammunition should be in accordance with FM 9-1.

# APPENDIX

## REFERENCES

### 1. Publication Indexes

The following indexes should be consulted frequently for latest changes or revisions of references given in this appendix and for new publications relating to materiel covered in this technical manual.

Indexes of Army Motion Pictures, Film Strips, Slides, and Phonorecordings.	DA Pam 108-1
Military Publications:	
Index of Administrative Publications .....	DA Pam 310-1
Index of Blank Forms .....	DA Pam 310-2
Index of Graphic Training Aids and Devices .....	DA Pam 310-5
Index of Supply Manuals; Ordnance Corps .....	DA Pam 310-29
Index of Tables of Organization and Equipment, Tables of Organization, Type Tables of Distribution, and Tables of Allowances.	DA Pam 310-7
Index of Technical Manuals, Technical Bulletins, Supply Bulletins, Lubrication Orders, and Modification Work Orders.	DA Pam 310-4
Index of Training Publications .....	DA Pam 310-3

### 2. Supply Manuals

The following manuals of the Department of the Army supply manual pertain to this materiel:

#### a. Ammunition.

Ammunition, 75-Millimeter Through 125-Millimeter .....	SM 9-5-1315
Ammunition, Over 30 Millimeter up to 75 Millimeter .....	SM 9-5-1310
Ammunition and Explosives (Class 1390 Fuzes and Primers).	SM 9-5-1390

#### b. Destruction.

Ammunition: Explosives, Bulk Propellants, and Explosive Devices.	SM 9-5-1375
--	-------------

#### c. General.

Introduction .....	ORD 1
--------------------	-------

#### d. Maintenance and Repair.

Tool Kit; Field Maintenance, Explosive Ordnance Disposal Squad (FSN 5180-754-0644).	SM 9-4-5180-J8-1
Tool Set, Maintenance (Field), Ammunition Renovation Platoon (41-T-3499-85).	ORD 6 SNL J-8, Sec 4

### 3. Forms

The following forms pertain to ammunition covered in this manual:

DA Form 468, Unsatisfactory Equipment Report	
DA Form 2028, Recommended Changes to DA Technical Manual Parts Lists or Supply Manual 7, 8, or 9 (cut sheet)	
DD Form 6, Report of Damaged or Improper Shipment	
OO Form 517, Ammunition Condition Report	

### 4. Other Publications

The following explanatory publications contain information pertinent to this ammunition and associated equipment:

<i>a. Ammunition.</i>	
Ammunition, General .....	TM 9-1900/TO 11A-1-20
Ammunition, Restricted or Suspended .....	TB 9-AMM 2/TO 39B-1-1
Ammunition for Training .....	TA 23-100
Ammunition Renovation .....	TM 9-1905
Ammunition Surveillance Manual .....	OFSB 3-20
Artillery Ammunition .....	TM 9-1901/TO 11A-1-22
Ballistic Data, Performance of Ammunition .....	TM 9-1907
Care, Handling, Preservation, and Destruction of Ammunition.	TM 9-1903/TO 11A-1-37
Demolition Materials .....	TM 9-1946
Disposal of Supplies and Equipment: Ammunition .....	SR 755-140-1
Explosives: Disposal by Dumping at Sea .....	SR 75-70-10/AFR 68-3
Military Explosives .....	TM 9-1910/TO 11A-1-34
Qualification in Arms: Qualification and Familiarization.	AR 370-5
Safety:	
Coordination with Armed Services Explosive Safety Board.	SR 385-15-1/AFR 14-12
Identification of Inert Ammunition and Ammunition Components.	AR 385-65
Regulations for Firing Ammunition for Training, Target Practice, and Combat.	AR 385-63/AFR 50-13
Supply Control: Distribution of Ammunition for Training.	AR 710-1300-1
Transportation and Travel: Transportation by Water of Explosives and Hazardous Cargo.	AR 55-228
<i>b. Mortars.</i>	
60-mm Mortar M19 .....	FM 23-85
81-mm Mortar M29 .....	FM 23-90
Mortar, Chemical, 4.2-inch .....	TM 3-320
Operation and Organizational Maintenance: 4.2-Inch Mortar M30 and 4.2-Inch Mortar Mounts M24 and M24A1.	TM 9-2008
Operation and Organizational Maintenance: 81-mm Mortar M29, 81-mm Mortar Mounts M23 and M23A1; and 81-mm Mortar Baseplates M23 and M23A1.	TM 9-3064
<i>c. Camouflage.</i>	
Camouflage, Basic Principles and Field Camouflage.	FM 5-20
<i>d. Decontamination.</i>	
Decontamination .....	TM 3-220
Small Unit Procedures in Atomic, Biological, and Chemical Warfare.	FM 21-40
<i>e. Destruction to Prevent Enemy Use.</i>	
Explosives and Demolitions .....	FM 5-25
<i>f. General.</i>	
Ammunition: Supply Within the Continental United States.	SB 9-AMM 6
Artillery Materiel and Associated Equipment .....	TM 9-2300
Inspection of Ordnance Materiel in Hands of Troops .....	TM 9-1100
Installations:	
Administration .....	AR 210-10
Report of Loss, Theft, and Recovery of Government Property in the Continental United States.	AR 210-84
Malfunctions Involving Ammunition and Explosives .....	AR 700-1300-8
Logistics (General):	
Unsatisfactory Equipment Report .....	AR 700-38
Military Chemistry and Chemical Agents .....	TM 3-215

Military Security: Safeguarding Defense Information.	AR 380-5
Military Symbols .....	FM 21-30/AFM 55-3
Military Terms, Abbreviations, and Symbols:	
Authorized Abbreviations and Brevity Codes .....	AR 320-50
Dictionary of United States Army Terms .....	AR 320-5
Military Training .....	FM 21-5
Ordnance Ammunition Service .....	FM 9-5
Ordnance Major Items and Major Combinations and Pertinent Publications.	SB 9-1
Ordnance Service in the Field .....	FM 9-1
Safety: Accident Reporting and Records .....	AR 385-40
Supply and Service Installations and Activities:	
Depots—Organization and Command Relationship .....	AR 780-10
Tactics and Techniques of Chemical, Biological, and Radiological (CBR) Warfare.	FM 3-5
Targets, Target Material, and Training Course Lay-Outs.	TM 9-855
Techniques of Military Instructions .....	FM 21-6
Transportation and Travel: Military Traffic Management Regulation.	AR 55-355
<i>g. Maintenance and Repair.</i>	
Maintenance of Supplies and Equipment: Spot Check Inspection and Reports; Ordnance Corps Materiel.	AR 750-925
Ordnance Maintenance: Materials Used for Cleaning, Preserving, Abrading, and Cementing Ordnance Material, and Related Materials Including Chemicals, Lubricants, Indicators, and Hydraulic Fluids.	TM 9-1007
<i>h. Shipment and Limited Storage.</i>	
General Packaging Instructions for Ordnance General Supplies.	TM 9-200
Issue of Supplies and Equipment: Preparation, Processing, and Documentation for Requisitioning, Shipping, and Receiving.	AR 725-5
Logistics (General): Report of Damaged or Improper Shipment.	AR 700-58
Marking and Packing of Supplies and Equipment: Marking of Supplies for Shipment.	AR 746-80
Protection of Ordnance General Supplies in Open Storage.	TB ORD 379
<b>5. Firing Tables</b>	
12-Inch Graphical Firing Tables .....	TM 9-524
Graphical Firing Tables; M39, M40, M41, M42, M43, M44, M45, M46, M47, M48, M49, M50, and M51.	TM 9-525

# INDEX

	Paragraph	Page		Paragraph	Page
Accidents, field report of -----	3b	3	WP, M57A1, w/fuze, PD,		
Adapters -----	84	91	M525A1, M525, or TSQ,		
Ammunition:			M77 -----	23	25-27
4.2-inch mortar cannon -----	28-35	28-41	M301A1 or M301A2, illuminating, w/fuze, time, M84 --	22	23-25
60-mm mortars -----	13-17	7-15	M362, HE, w/fuze, PD, M524 (or PD M526 series or PD M519 or proximity, M517)	21	20-23
81-mm mortars -----	18-27	15-28	M370, smoke, WP, w/fuze, PD, M524 -----	24	27
Classification -----	5	4	4.2-inch:		
Destruction to prevent enemy use --	89-91	94, 95	General -----	28a	28
Packed -----	90b	95	M2 or M2A1, gas, nonpersistent, Co, or presistent, H, HD, or HT, w/fuze, PD, M8 -----	29	33-35
Percussion primers -----	64c	84	M2 or M2A1, smoke, PWP, or WP, w/fuze, PD, M8 --	34	41
Unpacked -----	90a	94, 95	M3, HE, w/fuze, PD, M9 --	31	37
Arming fuzes, methods of -----	36e	44	M3A1 (or M3A1 alt), HE, w/supplementary charge and fuze, MTSQ, M500A1 (or M500), PD, M51A5, 0.05-second delay, PD, M535, proximity, M513A1, M513B1, or M513 -----	30	35-37
Authorized forms -----	3a	3	M328, smoke, WP, w/fuze, PD, M521 -----	35	41
Boosters:			M329, HE, w/supplementary charge and fuze, MTSQ, M500A1 (or M500), PD, M51A5, 0.05-second delay, PD, T177E3, proximity, M513A1, M513B1, or M513	32	37
General -----	75	88	M335, illuminating, w/fuze, MTSQ, M501A1 (or M501)	33	37-41
M21A4 -----	76	88, 89	Ignition:		
M124 -----	77	89, 90	Data (table V) -----		85
M125 -----	39d, 78	51, 52, 90	General -----	64	84-86
Boresafe fuze -----	36d	42-44	M2, 4.2-inch -----	28f, 65	33, 86
Burst height, proximity fuze, M517 --	58f	79	M3, 81-mm -----	66	86
Bursters:			M4, 60-mm -----	67	86
General -----	79	90	M5A1, 60-mm -----	68	86
M1 -----	80	90	M6 -----	69	86
M19 -----	81	90	M8 -----	70	86
T74 -----	82	90	M66 -----	71	86, 87
Card, special instructions, for proximity fuzes -----	56c	74	Characteristics, proximity fuzes -----	56d	74
Care, handling, and preservation:			Charges:		
General -----	8	4, 5	Propelling:		
Proximity fuzes -----	56f	75-77	4.2-inch mortar cannon 28e, 63	32, 33,	82-84
Cartridges:			60-mm mortar -----	13e, 61	8, 82
60-mm:			81-mm mortar -----	18e, 62	16, 17, 82
General -----	13	7-10	Data (table I) -----		17
M49A2, HE, w/fuze, PD, M525A1 or M525 -----	14	10	General -----	60	80-82
M83A3, M83A2, or M83A1, illuminating, w/fuze, time (fixed), M65A1 or M65 --	15	10-12			
M302, smoke, WP, w/fuze, PD, M527A1 or M527 --	16	12			
81-mm:					
General -----	18a	15			
M43A1, TP, w/fuze, PD, M52 series, modified --	25	27			
M43A1, TP w/fuze, PD, M525A1 or M525 -----	26	27, 28			
M43A1 or M43A1E1, HE, w/fuze, PD, M525A1 or M525 -----	19	17-20			
M56A1 or M56, HE, w/fuze, PD, M525A1, M525, M53A1, or TSQ, M77 --	20	20			
M57, smoke, WP, or FS or					

	Paragraph	Page
Supplementary .....	83	90, 91
Chemical projectile .....	10b	5
Classification:		
Fuzes .....	36b	42
General .....	5	4
Primers .....	64b	84
Climatic effects, proximity fuze, M517 ..	58i	80
Closing plugs .....	85	91, 92
Containers .....	11	5, 6
Crest clearance, proximity fuze, M517 ..	58g	79
Data:		
Ballistic:		
60-mm cartridge ( <i>See specific items</i> )		
81-mm cartridge ( <i>See specific items</i> )		
Fuzes ( <i>See specific items</i> )		
Physical:		
60-mm cartridge ( <i>See specific items</i> )		
81-mm cartridge ( <i>See specific items</i> )		
4.2-inch cartridge ( <i>See specific items</i> )		
Propelling charge (table I) .....	17	4
Definitions .....	4	4
Description:		
Boosters ( <i>See specific items</i> )		
Cartridges ( <i>See specific items</i> )		
Fuzes ( <i>See specific items</i> )		
Weapons .....	13a	7
Destruction of ammunition to prevent enemy use .....	89-81	94, 95
Determination of propellant weight ..	60b	81
Detonators:		
Fuze .....	36f	44
( <i>See also table II</i> )		
Devices, safety:		
M8 fuze .....	40b	52-54
M51A5 fuze .....	42e	57
M84 fuze .....	54d	69
Equipment, subcaliber:		
Ammunition .....	5b	4
General .....	86, 88	93
M31 .....	87	93
Fiber containers .....	11c	6
Field report of accidents .....	3b	3
Fin assembly:		
60-mm mortar and training projectiles .....	13g	8
81-mm mortar .....	18g	17
Firing tables .....	12	6
Forms and reports .....	3	3
Functioning:		
Boosters ( <i>See specific items</i> )		
Fuzes ( <i>See specific items</i> )		
Fuzes:		
4.2-inch mortar .....	28d	31, 32
60-mm mortar .....	13d	7, 8
81-mm mortar .....	18d	15, 16
Arming:		
Methods of .....	36e	44
System, for proximity fuze, M517 .....	58d	78, 79
Time, for proximity fuze,		

	Paragraph	Page
M517 .....	58e	79
Boresafe .....	36d	42-44
Classification .....	36b	42
Description:		
For cartridges .....	13d	7, 8
General .....	36c	42
Detonators:		
General .....	37h	48-50
( <i>See also table II</i> )		
Interchangeability .....	36g	44-46
Mechanical time and superquick:		
M500A1 (or M500) 30, 32, 37	35-37, 37, 48-50	
M501A1 (or M501) .....	33, 38	37-41, 50, 51
M520 .....	39	51, 52
Packing and shipping .....	36i	46-48
Point detonating:		
M8 .....	29, 34, 40	33-35, 41, 52-55
M9 .....	31, 41	37, 55
M51A5, 0.05-second delay .....	30, 32, 42	35-37, 37, 55-58
M52 series, modified .....	25, 43	27, 58
M53A1 .....	20, 44	20, 58-63
M82, M82A1, or M82A1B1 ..	45	63
M519 .....	46	63
M521 .....	34, 47	41, 63
M524 .....	21, 24, 48	20-23, 27, 63, 64
M525A1 and M525:		
Cartridge, 60-mm		
M49A2 .....	14	10
Cartridge, 81-mm:		
M43A1 or		
M43A1B1 ..	19, 26	17-20, 27, 28
M56A1 or M56 ..	20	20
M57, M57A1 ..	23	25-27
General .....	49	64, 65
M526 series .....	21	20-23
M526A1 (or M526) .....	50	65
M527A1, M527 or M527B1, and M527A1B1 .....	16, 51	12, 66
M535 (T177E3), 0.05-second delay .....	80, 32, 52	35-37, 37, 66
Proximity:		
General .....	56	74-77
M518 .....	30, 32	35-37, 37
M513A1 .....	30, 32, 57	35-37, 37, 77, 78
M518B1 .....	30, 32	35-37, 37
M517 .....	21, 58, 59	20-23, 78-80, 80
Setters (table III) .....		47
Setters .....	36h	46
Time:		
M65A1 or M65 (Fixed) ..	15, 53	10-12, 66-69
M84 .....	22, 54	23-25, 69-73
Time and superquick, M77 20, 23, 55	20, 25-27, 73, 74	
Wrenches .....	36h	46
Handling, care, and preservation .....	8	4, 5
High-explosive (HE) projectile .....	10a	5
Identification:		
4.2-inch mortar cartridges .....	28b	28, 31
60-mm mortar cartridges .....	13b	7
81-mm mortar cartridges .....	18b	15

	Paragraph	Page		Paragraph	Page
General -----	7	4	60-mm, training, M69 (w/o fin assembly) -----	7	4
Propelling charges -----	60c	81	81-mm:		
Proximity fuzes -----	56b	74	Mortars -----	18c	15
Ignition cartridges ( <i>See</i> Cartridges, ignition)			Training, M68 -----	27	28
Illuminating projectile -----	10c	5	For proximity fuzes -----	10f	5
Instruction card, special, for proximity fuzes -----	56c	74	General -----	10	5
Interchangeability, fuze -----	36g	44-46	Type of -----	13c	7
Malfunctions, proximity fuze, M517 ---	59h	79, 90	Propellant -----	60a, b	80, 81
Marking and packing -----	11	5, 6	Propelling charge data (table I) -----		17
Marking for shipment -----	11e	6	Propelling charges ( <i>See</i> Charges, propelling)		
Methods of arming ( <i>See</i> Arming)			Purpose of manual -----	1	3
Methods of destruction -----	90	94, 95	Reports -----	3	3
Mortar cannon, propelling charge:			Safety devices ( <i>See</i> Devices, safety)		
60-mm -----	61	82	Scope -----	2	3
81-mm -----	62	82	Service ammunition -----	5a	4
Mortars:			Setters:		
60-mm, cartridges for -----	13-17	7-15, 12-15	Fuze -----	36h	46
81-mm, cartridges for -----	18-27	15-28, 28	( <i>See also</i> table III)		
Propelling charges for -----	60d	82	Setting, fuze, M51A5 -----	42d	57
Nomenclature, standard -----	6	4	Shipping and packing ( <i>See</i> Packing and shipping)		
Packed ammunition, destruction -----	90b	95	Smoke projectile -----	10b	5
Packing and marking -----	11	5, 6	Special instruction card for proximity fuzes -----	56c	74
Packing and shipping data:			Standard nomenclature -----	6	4
4.2-inch cartridges -----	28h	33	Storage precautions -----	9	5
60-mm cartridges -----	13h	10	Subcaliber equipment ( <i>See</i> Equipment, subcaliber)		
81-mm cartridges -----	18h	17	Supplementary charges -----	83	90, 91
Fuzes -----	36i	46-48	Tables:		
Ignition cartridges -----	64d	86	Authorized use of proximity fuzes (table IV) -----		75
Primers -----	64d	86	Detonators (table II) -----		46
Plugs, closing -----	85	91, 92	Fuze setters (table III) -----		47
Practice ammunition -----	5a	4	Primer and ignition cartridge data (table V) -----		85
Precautions:			Propelling charge data (table I) -----		17
In firing fuze M51A5 -----	42h	58	Tables, firing -----	12	6
In use of fuze M520 -----	39f	52	Target-practice projectiles -----	10d	5
Storage -----	9	5	Training ammunition -----	5a	4
Preparation for firing:			Training projectiles -----	10e	5
Booster M21A4 -----	76d	89	Type of projectiles ( <i>See specific items</i> )		
Fuzes ( <i>See specific items</i> )			Unpacked ammunition, destruction of --	90a	94, 95
Preservation, care, and handling -----	8	4, 5	Use, proximity fuzes -----	56e	74, 75
Primers:			Weapon description ( <i>See specific items</i> )		
Data (table V) -----		85	Weight, propellant, determination of --	60b	81
General -----	64	84-86	Wrenches, fuze -----	36h	46
Percussion:					
60-mm -----	13f, 72	8, 87			
81-mm -----	18f, 73	17, 87, 88			
M71 -----	74	88			
Priority, destruction of ammunition ---	91	95			
Projectiles:					
4.2-inch -----	28c	31			

L. L. LEMNITZER,  
*General, United States Army,*  
*Chief of Staff.*

Official:

R. V. LEE,  
*Major General, United States Army,*  
*The Adjutant General.*

Distribution:

*Active Army:*

To be distributed in accordance with DA Form 12-7 requirements for TM 9-series (Uncl) plus the following formula:

DCSLOG (1)	9-12
Tech Stf, DA (1) except	9-17
CofOrd (9)	9-22
US ARADCOM (2)	9-26
US ARADCOM Rgn (2)	9-76
Seventh US Army (3)	9-86
EUSA (3)	9-367
Corps (2)	9-500
Raritan Arsenal (28)	9-510
Units org under fol TOE: (2 copies each)	

*NG:* State AG (3); Units—Same as Active Army except allowance is one copy for each unit.

*USAR:* None.

For explanation of abbreviations used, see AR 320-60.