

**TECHNICAL MANUAL**

**OPERATOR'S, ORGANIZATIONAL, DIRECT SUPPORT,  
AND GENERAL SUPPORT MAINTENANCE MANUAL  
(INCLUDING REPAIR PARTS AND SPECIAL TOOLS LISTS)**

**FLAMETHROWER, PORTABLE, M2A1-7**

**FSN 1040-586-4560**

## **WARNINGS**

To prevent injury to personnel, stand to either side of the coupling plug prior to removal. A faulty pressure regulator could cause a pressure build-up in the fuel tanks. The pressure could blow the plug out with great force when the coupling cams are released.

To prevent burns, handle ignition cylinders with extreme care as they contain incendiary material.

To prevent burn casualties, keep the gun pointed away from friendly personnel at all times and never face the front of the gun.

Release the waist straps before firing to facilitate emergency disposal of the flamethrower during firing.

To prevent burns, protect the hands before handling the nozzle shield after firing.

During firing, the gunner must be alert against head winds that may blow the flame back on him.

To prevent eye injuries or accidental fires, do not use the hose if the 2-year service life is exhausted or if the 5-year storage life is exhausted.

To prevent eye injuries, vent the pressurized air from the air pressure system before attempting any maintenance or modification to the pressure system.

To prevent injury to personnel, slowly release the pressure on the inlet body to prevent the inlet body and springs under tension from flying off the needle valve.

TECHNICAL MANUAL }  
 No. 3-1040-204-14 }

HEADQUARTERS  
 DEPARTMENT OF THE ARMY  
 WASHINGTON, D.C., 9 November 1973

**OPERATOR'S, ORGANIZATIONAL, DIRECT SUPPORT, AND GENERAL SUPPORT  
 MAINTENANCE MANUAL  
 (Including Repair Parts and Special Tools Lists)**

**FLAMETHROWER, PORTABLE, M2A1-7  
 FSN 1040-586-4560**

	Paragraph	Page
CHAPTER 1. INTRODUCTION		
Section I. General .....	1-1	1-1
II. Description and Data .....	1-3	1-1
CHAPTER 2. OPERATING INSTRUCTIONS		
Section I. Controls .....	2-1	2-1
II. Operation Under Usual Conditions .....	2-7	2-1
III. Operation Under Unusual Conditions .....	2-13	2-4
CHAPTER 3. OPERATOR'S MAINTENANCE INSTRUCTIONS		
Section I. Inspection .....	3-1	3-1
II. Preventive Maintenance Checks and Services .....	3-3	3-1
CHAPTER 4. ORGANIZATIONAL MAINTENANCE INSTRUCTIONS		
Section I. Service Upon Receipt of Material .....	4-1	4-1
II. Painting and Lubricating .....	4-8	4-2
III. Servicing .....	4-11	4-3
IV. Preventive Maintenance Checks and Services .....	4-15	4-5
V. Troubleshooting .....	4-20	4-6
VI. Tank .....	4-22	4-7
CHAPTER 5. DIRECT SUPPORT MAINTENANCE INSTRUCTIONS		
Section I. Gun .....	5-1	5-1
II. Hose .....	5-5	5-5
III. Tanks .....	5-7	5-5
CHAPTER 6. GENERAL SUPPORT MAINTENANCE INSTRUCTIONS		
Section I. Testing and Servicing .....	6-1	6-1
II. Gun .....	6-5	6-2
III. Fuel .....	6-8	6-5
IV. Pressure .....	6-9	6-5
CHAPTER 7. SHIPMENT, ADMINISTRATIVE STORAGE, AND DESTRUCTION TO PREVENT ENEMY USE		
Section I. Shipment and Administrative Storage .....	7-1	7-1
II. Destruction to Prevent Enemy Use .....	7-3	7-1
APPENDIX A. REFERENCES .....		A-1
B. BASIC ISSUE ITEMS AND ITEMS TROOP INSTALLED OR AUTHORIZED LIST AND ORGANIZATIONAL, DIRECT SUPPORT, AND GENERAL SUPPORT MAINTENANCE REPAIR PARTS AND SPECIAL TOOLS LIST (INCLUDING DEPOT MAINTENANCE REPAIR PARTS AND SPECIAL TOOLS) .....		B-1
C. MAINTENANCE ALLOCATION CHART .....		C-1
INDEX .....		I-1

## LIST OF ILLUSTRATIONS

<i>Number</i>	<i>Title</i>	<i>Page</i>
1-1	M2A1-7 portable flamethrower .....	1-2
1-2	Gun and hose assembly .....	1-3
1-3	Nozzle shield, installed .....	1-3
1-4	Tank coupling and fuel hose .....	1-4
1-5	Pressure tank and fuel tanks .....	1-4
1-6	Pressure tank and valve assembly .....	1-5
1-7	Pressure regulator and fuel tanks .....	1-6
1-8	Carrier pack .....	1-7
1-9	Identification plates .....	1-7
1-10	Ignition cylinder .....	1-7
1-11	Fuel and air pressure system .....	1-9
2-1	Ignition cylinder .....	2-2
4-1	M2A1-7 portable flamethrower in packing chest .....	4-1
4-2	Pressure tank and valve assembly .....	4-4
4-3	Filling plug and preformed packing requirement .....	4-7
4-4	Carrier section, exploded view .....	4-8
5-1	Ignition section of gun exploded view .....	5-2
5-2	Installing ignition pin assembly .....	5-3
5-3	Inserting pin in ignition link .....	5-3
5-4	Installing ignition lever assembly and safety lever assembly .....	5-3
5-5	Valve section, exploded view .....	5-4
5-6	Pressure section, exploded view .....	5-7
6-1	Barrel-and-inlet body, exploded view .....	6-3
6-2	Removing valve retractor .....	6-4
6-3	Holding device and valve wrench .....	6-6
6-4	Pressure tank and pressure tank valve .....	6-7
6-5	Pressure regulator, safety valve, and safety head, exploded view .....	6-9
B-1	Gun group, ignition head and grip section .....	B-5
B-2	Gun group, valve section .....	B-6
B-3	Gun group, valve section, valve grip parts .....	B-7
B-4	Hose group .....	B-8
B-5	Tank group, fuel section .....	B-9
B-6	Tank group, pressure section .....	B-10
B-7	Tank group, pressure section regulator and safety valve .....	B-11
B-8	Tank group, carrier section .....	B-12

## CHAPTER 1

### INTRODUCTION

---

#### Section I. GENERAL

##### 1-1. Scope

These instructions are for use by the operator, organizational, direct support, and general support maintenance personnel. They apply to the Flamethrower, Portable, M2A1-7.

##### 1-2. Record and Report Forms

a. Department of the Army forms and pro-

cedures used for equipment maintenance will be those prescribed by TM 38-750.

b. The reporting of errors, omissions, and recommendations for improving this publication by the individual user is encouraged. Reports should be submitted on DA Form 2028 (Recommended Changes to Publications) and forwarded directly to Commander, Edgewood Arsenal, Attn: SAREA-DE-ET, Aberdeen Proving Ground, Md. 21010.

#### Section II. DESCRIPTION AND DATA

##### 1-3. Description

The M2A1-7 flamethrower (fig. 1-1) is an individual assault weapon. It is used primarily in close combat as an antipersonnel weapon. The flamethrower projects a flaming rod of thickened fuel to produce casualties and destroy materiel. Two tanks contain the fuel and one tank contains the compressed air. The hose carries the fuel from the fuel tanks to the gun. The gun controls the flow and ignition of the fuel.

##### 1-4. Gun

The gun (fig. 1-2) consists of a valve section and ignition section.

a. *Valve Section.* The valve section includes the valve safety lever (3) and valve lever (4). An inner barrel and nozzle extend into the ignition section.

b. *Ignition Section.* The ignition section includes the ignition safety lever (7), ignition lever (6), nozzle shield (8), and ignition cylinder (para 1-8). A shield latch (fig. 1-3) locks the removable nozzle shield in place. The two adjustment screws (5, fig. 1-2) permit the operator to rotate the ignition section for a more comfortable firing position.

##### 1-5. Hose Assembly

The fabric-covered hose (2, fig. 1-2) has a quick-disconnect coupling half (1) at one end and a threaded coupling at the other end. The threaded coupling is connected to the gun valve section. The quick-disconnect coupling half (1) is connected to the fuel tank outlet coupling body (2, fig. 1-4).

##### 1-6. Air Pressure Tank and Fuel Tanks

a. *Air Pressure Tank*

(1) *Pressure tank and valve assembly.* The pressure tank (2, fig. 1-5) is a cylindrical steel tank which contains the pressurized air for dispersing the fuel from the fuel tanks (b below). A pressure tank valve (fig. 1-6) assembly is screwed into the base of the pressure tank. The valve assembly contains a check valve and cap. The cap protects the check valve and is removed when the cylinder is to be recharged with air. A coupling plug is also assembled to the valve assembly. It is the direct connection for the quick-disconnect coupling half (fig. 1-7). The coupling plug (fig. 1-6) is covered with a cap when the pressure tank is disconnected from the quick-disconnect coupling half (fig. 1-7). A valve handle connected to the valve shaft operates a valve that controls the flow of pressurized air from the pressure tank. The



MU393401

Figure 1-1. M2A1-7 portable flamethrower.

pressure tank is strapped to the fuel tanks (1, fig. 1-5). A hinged tank clamp (2) holds the pressure tank in place. The valve shaft (5) is clamped to the body of the fuel tank with a clamp and wing-nut. For maximum efficiency, air pressure is between 1,700 psi and 2,100 psi.

(2) *Pressure regulator and tube assembly.* The pressure regulation reduces the air pressure coming from the pressure tank. One end of a tube

assembly (fig. 1-7) is connected to the inlet side of the pressure regulator. The other end of the tube contains a quick-disconnect coupling half. This coupling is the connection for the pressure tank coupling plug (fig. 1-6).

(3) *Safety Valve.* The safety valve (fig. 1-7) is connected to the outlet side of the pressure regulator. It contains the safety head and a fuel check valve. A disk in the safety head will rupture when

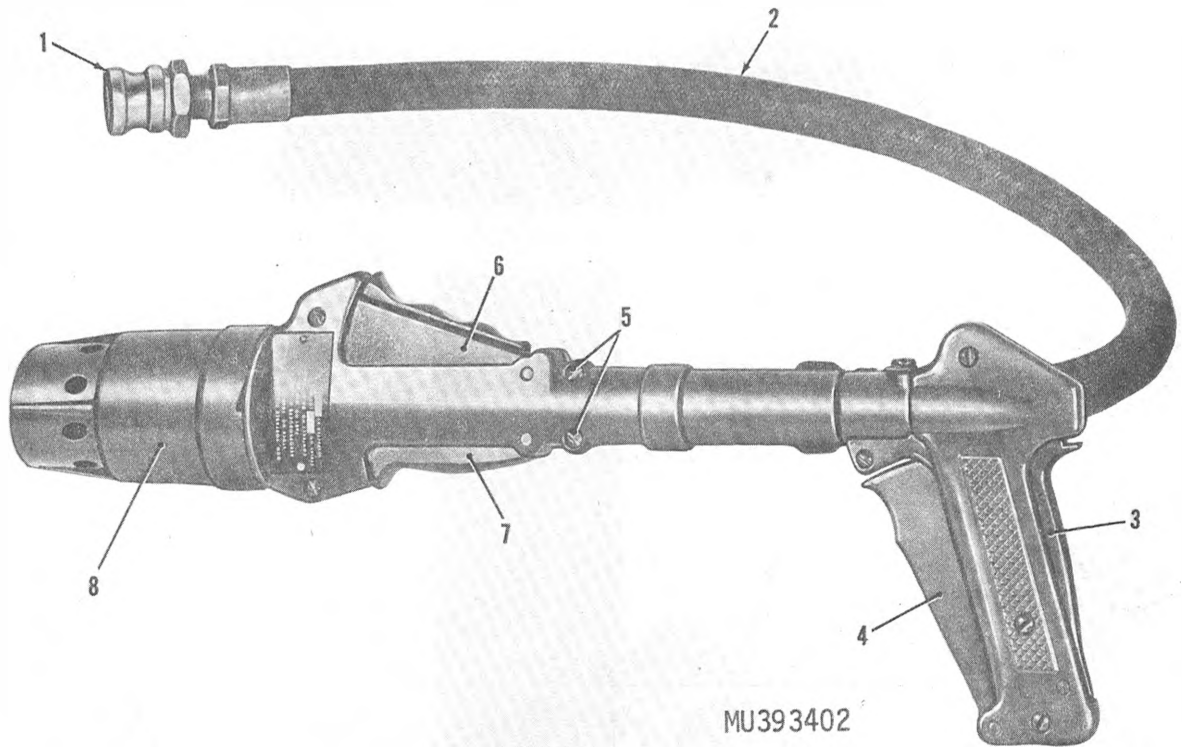

1 Quick-disconnect coupling half  
2 Hose assembly

3 Valve safety lever  
4 Valve lever  
5 Screws

6 Ignition lever  
7 Ignition safety lever  
8 Nozzle shield

Figure 1-2. Gun and hose assembly.

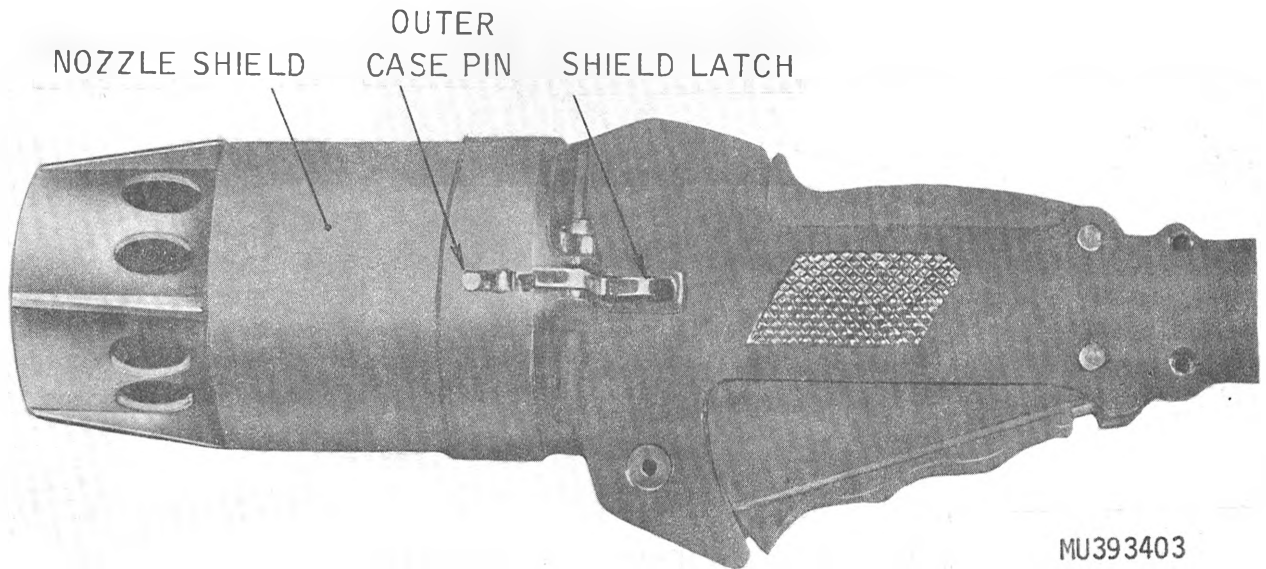
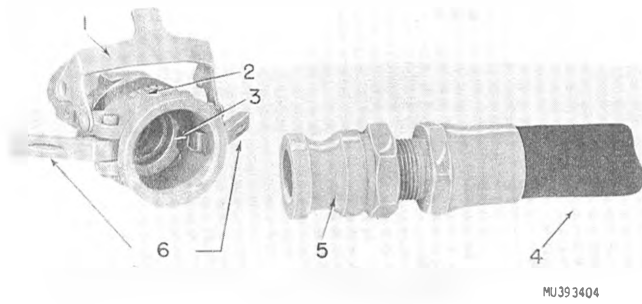
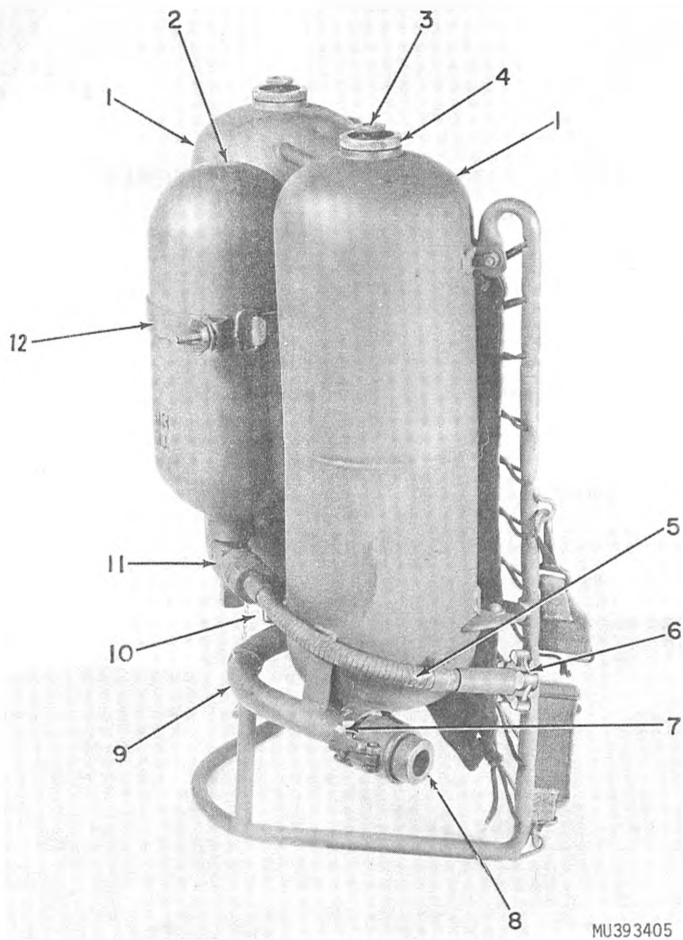

Figure 1-3. Nozzle shield, installed.



- |   |               |   |              |
|---|---------------|---|--------------|
| 1 | Coupling lock | 4 | Hose         |
| 2 | Coupling body | 5 | Coupling     |
| 3 | Gasket        | 6 | Coupling cam |

Figure 1-4. Tank coupling and fuel hose.



- |   |               |    |                                |
|---|---------------|----|--------------------------------|
| 1 | Fuel tank     | 7  | Quick-disconnect coupling lock |
| 2 | Pressure tank | 8  | Coupling plug                  |
| 3 | Bleeder valve | 9  | Fuel delivery pipe             |
| 4 | Filling plug  | 10 | Tank connector                 |
| 5 | Valve shaft   | 11 | Pressure tank valve            |
| 6 | Valve handle  | 12 | Hinged tank clamp              |

Figure 1-5. Pressure tank and fuel tanks.

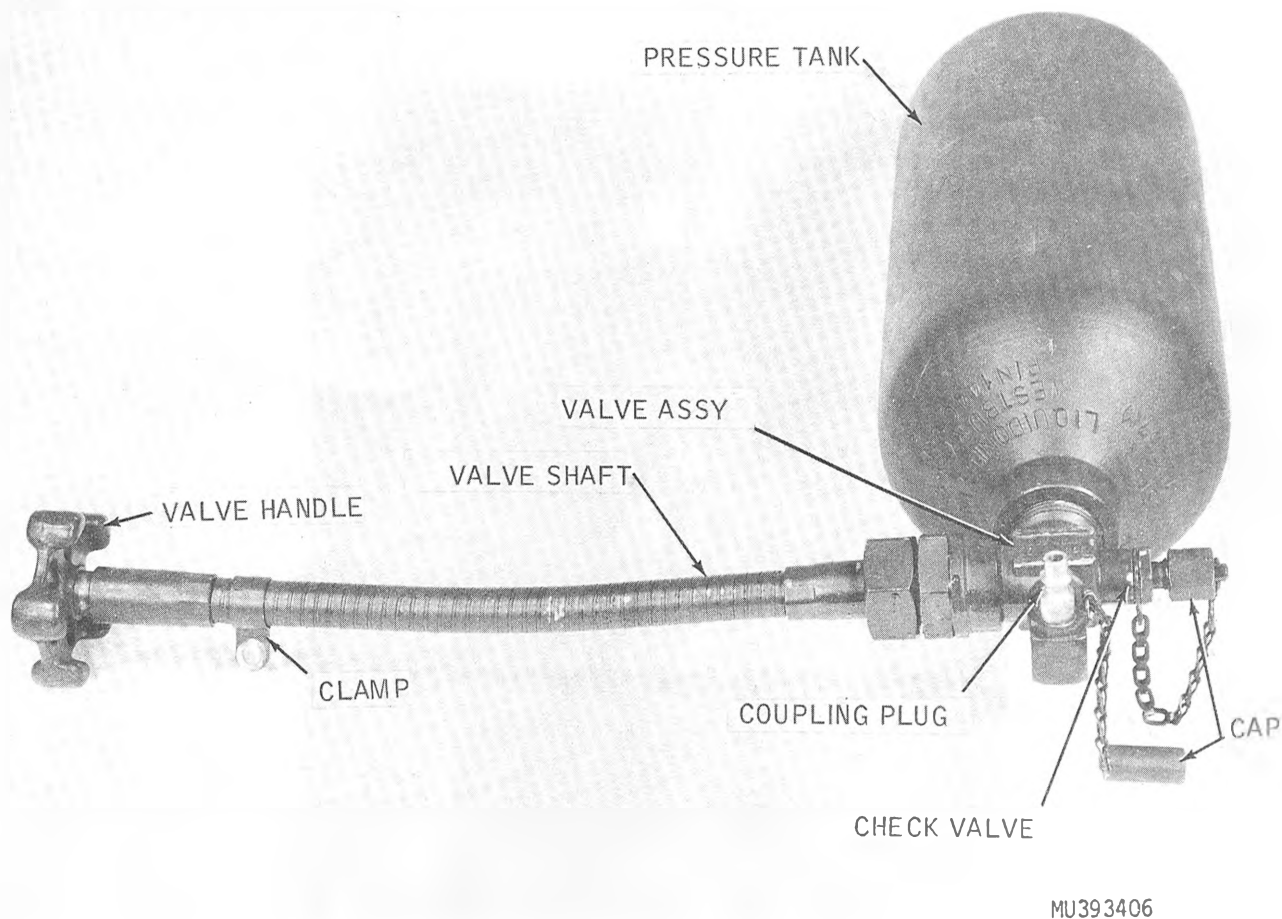

Figure 1-6. Pressure tank and valve assembly.

air pressure in the safety valve rises to a pressure between 525 and 625 psi. The fuel check valve in the safety valve closes when the safety head disk bursts. This prevents fuel from backing up into the regulator and allows the firing of one burst.

#### b. Fuel Tanks.

(1) *Filling plug.* The filling plug (fig. 1-7) is screwed into the top of each fuel tank.

(2) *Fuel tanks.* Two cylindrical tanks (fig. 1-7) are connected near the top by the interconnecting diffusion pipe and near the bottom by the interconnecting tank connector. The agent delivery pipe is welded to the interconnecting tank connector. The open end of the agent delivery pipe contains the quick-disconnect coupling for the quick-disconnect coupling half (1, fig. 1-2). A removable coupling plug (fig. 1-7) covers the open end of the delivery pipe when the hose is disconnected from the agent delivery pipe. The plug is stowed in the packing chest when not in use. A hinged clamp is welded to both tanks and is used to

hold the pressure tank in place. The clamp is locked in place by a wingnut.

(3) *Carrier pack.* The carrier pack (fig. 1-8) consists of a tubular frame, carrier, and strap assemblies. The carrier pack is attached to the tubular frame (7) with cotton cords (8). The upper shoulder straps are attached to pins (1). The lower shoulder straps, at one end, are attached to the lower part of the tubular frame. The upper and lower shoulder straps are connected together by quick-release fasteners (4). The body straps are attached at one end of the tubular frame and are connected by a breakaway buckle fastener. The carrier pack provides a means for the operator to conveniently carry the fuel tanks on his back during use and operation of the flamethrower.

### 1-7. Identification Plates

a. *Gun.* An identification plate (fig. 1-9) is riveted in back of the nozzle (fig. 1-2). The plate contains pertinent information on the gun.

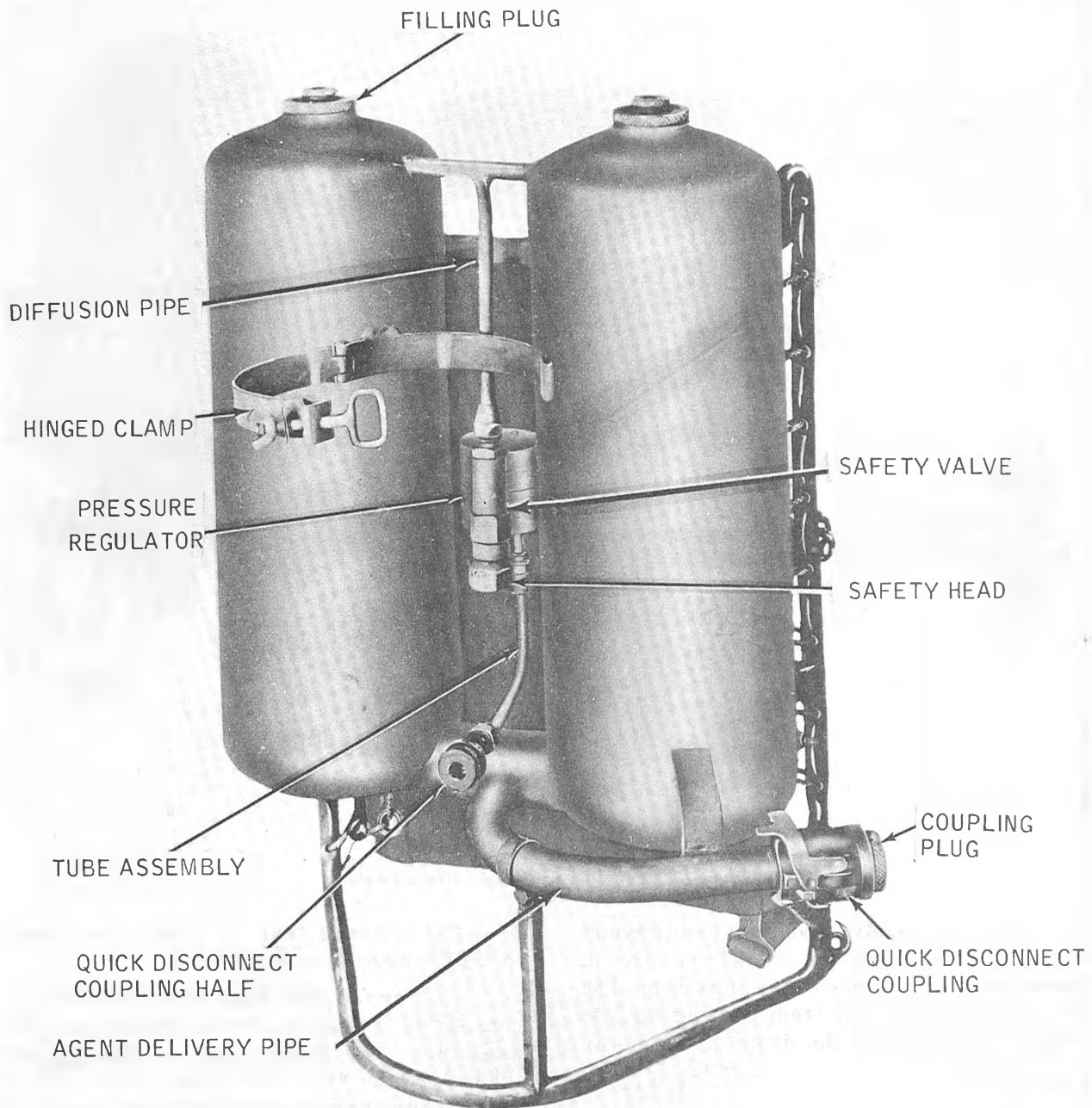

MU393407

Figure 1-7. Pressure regulator and fuel tanks.

b. *Tank.* An identification plate (fig. 1-9) is riveted to the upper shoulder strap support, located between the fuel tanks. The plate contains pertinent information on the fuel tanks.

### 1-8. Ignition Cylinders

Two ignition cylinders (fig. 1-10) are not supplied with this equipment; they are requisitioned separately. The ignition cylinder contains five

matches (2), that are coated with a striker mix (9). The following are located next to each match: a matchhead mixture (7), starter pellets (6), black powder (10), and incendiary pellets (4). The incendiary pellets are spaced and separated in the ignition cylinder body to prevent igniting the other four matches. Lead-foil seals (5), plastic closure places (8), and cement, waterproof the ignition cylinder. When the ignition safety lever (7, fig. 1-2) and ignition lever (6) are squeezed, the

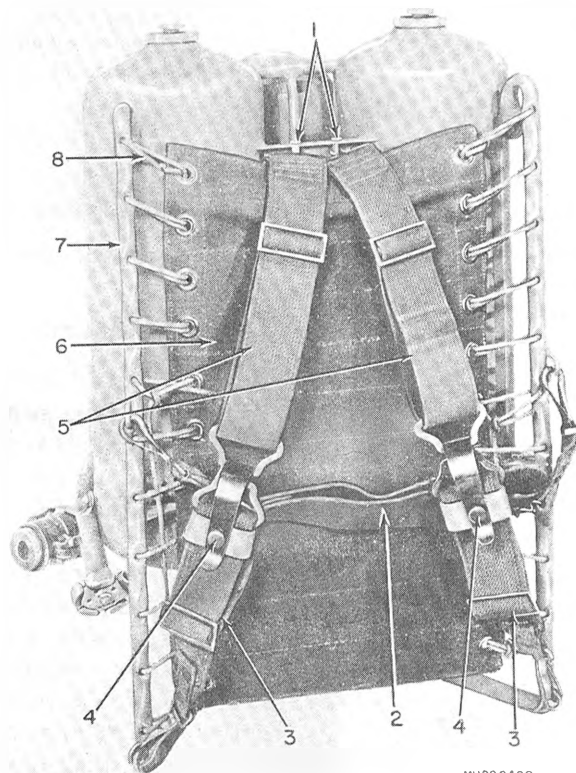

MU393408

- |                         |                           |         |
|-------------------------|---------------------------|---------|
| 1 Pins                  | 4 Quick release fasteners | 7 Frame |
| 2 Body straps           | 5 Upper shoulder straps   | 8 Cord  |
| 3 Lower shoulder straps | 6 Carrier                 |         |

Figure 1-8. Carrier pack.

ignition pin of the gun moves forward and forces the next match forward to be ignited. As the match travels forward, its abrasive striker mix scratches and ignites the matchhead mixture. When the matchhead is ignited, it ignites the starter pellet, black powder, and incendiary pellet. The incendiary pellet burns for 8 to 12 seconds and ignites the fuel as it is discharged from the gun nozzle.

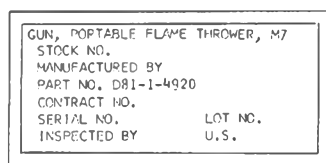

A. GUN NAMEPLATE

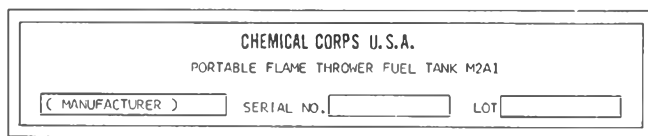

B. TANK NAMEPLATE

MU393409

Figure 1-9. Identification plates.

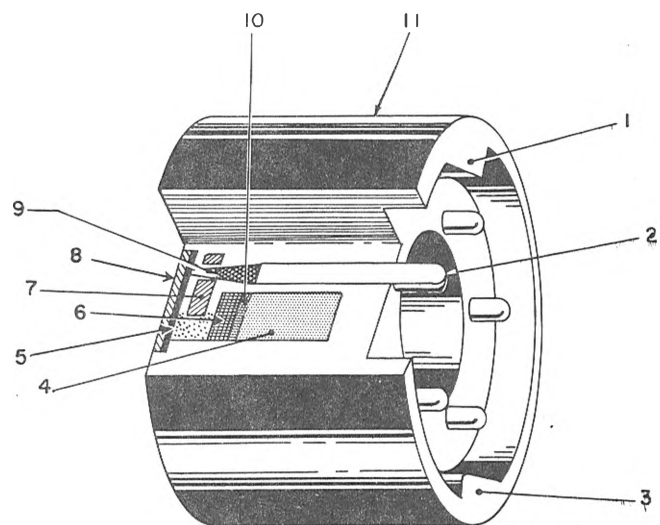

MU393410

- |                     |                           |
|---------------------|---------------------------|
| 1 Stop              | 6 Starter pellet          |
| 2 Match             | 7 Matchhead mixture       |
| 3 Stop              | 8 Plastic closure plate   |
| 4 Incendiary pellet | 9 Striker mix             |
| 5 Lead-foil seal    | 10 Black powder           |
|                     | 11 Ignition cylinder body |

Figure 1-10. Ignition cylinder.

**1-9. Tabulated Data**

(All data are approximate.)

*a. General.*

Range thickened fuel .....	40-50 meters
Range unthickened fuel .....	20-25 meters
Duration of fire .....	6-9 sec.

*b. Weights.*

M2A1-7 portable flamethrower packaged in packing chest ..	108 lb.
Flamethrower, empty (including gun and hose) .....	41.25 lb.
*Flamethrower, filled with fuel (including gun and hose) ..	65-69 lb.
M2A1 tank group, empty (including coupling plug) .....	35 lb.
*M2A1 tank group, filled with fuel (including coupling plug) ..	58.5-62.5 lb.
M8 fuel hose .....	1.75 lb.
M7 flame gun .....	4.5 lb.
Pressure tank and valve (including valve shaft and handle) ..	10.25 lb.

*c. Dimensions.*

M2A1 fuel tank:	
Height .....	27 in.
Width .....	20 in.
Depth .....	11 in.
M8 fuel hose:	
Length .....	37½ in.
Inside diameter .....	¾ in.
M7 gun, length .....	21 in.
Packing chest .....	8.4 cu ft.

*d. Fuel capacity*

4¾ gal.

*e. Pressures.*

Pressure tank .....	1,700-2,100 psi
Pressure regulator .....	300-350 psi
Safety head .....	525-625 psi
Fuel tank .....	300-350 psi

*f. Fuel Required for 100 Fillings.*

Flamethrower fuel (including 5% spillage and evaporation)	500 gal.
---	----------

\*Weights vary with type of fuel.

**1-10. Functioning**

When the valve handle (fig. 1-11) is turned counterclockwise, the pressure tank valve opens and pressurized air is released from the pressure tank. Pressurized air passes through the pressure tank valve and into the regulator tube and pressure regulator, when the air pressure is reduced to operating pressure. The air then enters the safety valve, which consists of a safety head and a check valve. The safety head disk is designed to burst when the air pressure in the safety valve rises to a pressure of 525 to 625 psi. A check valve in the outlet end of the safety valve closes when the safety head disk bursts. This prevents fuel from backing up into the regulator and allows the firing of one burst. Pressurized air entering the fuel tank mixes with the fuel. The pressure forces the fuel through the fuel delivery pipe into the hose assembly through the gun where it is ignited upon ejection.

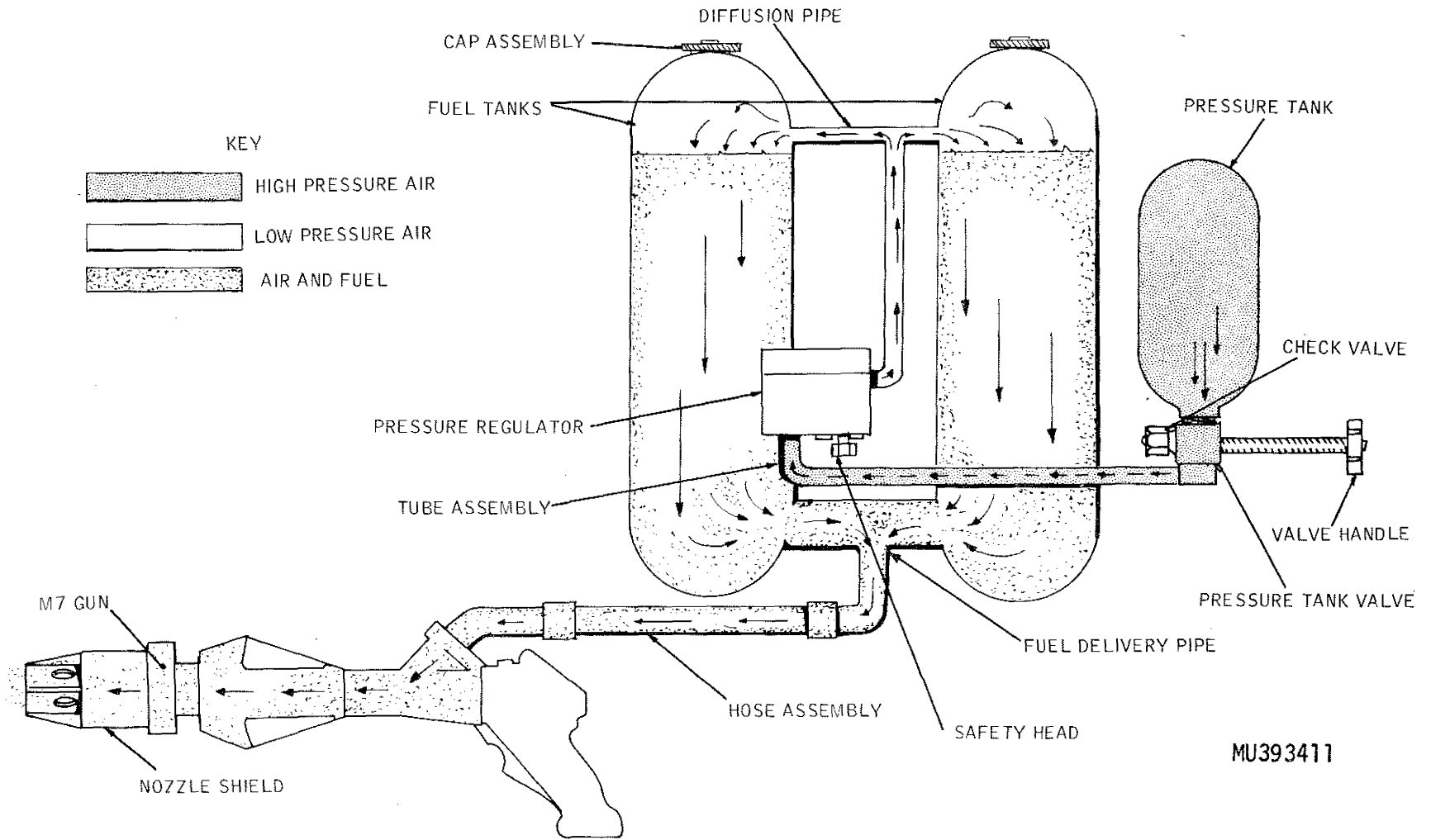

MU393411

Figure 1-11. Fuel and air pressure system.

## CHAPTER 2

### OPERATING INSTRUCTIONS

---

#### Section I. CONTROLS

##### 2-1. Pressure Tank Valve Handle

The pressure tank valve handle (6, fig. 1-5) is located at the lower right side of the fuel tank. It is located at the operator's right hip when he is carrying the fuel tank. The valve handle operates the pressure tank valve. Moving the handle counterclockwise opens the pressure tank valve and releases pressurized air to the fuel tanks. Moving the handle clockwise closes the valve.

##### 2-2. Valve Safety Lever

The valve safety lever (3, fig. 1-2) is located in back of the valve lever (4). It locks the valve lever and prevents accidental release of fuel. The valve safety lever must first be depressed by the palm of the hand, before the valve lever can be operated to release fuel.

##### 2-3. Valve Lever

The valve lever (4, fig. 1-2) is located in front of the valve safety lever (3). The valve lever controls the flow of fuel. To release fuel from the gun, squeeze the valve safety lever (3) and then squeeze the valve lever (4).

##### 2-4. Ignition Safety Lever

The ignition safety lever (7, fig. 1-2) is located on the side of the ignition grip. It locks the ignition lever (6) and prevents the matches from igniting accidentally in the ignition cylinder (para 1-8).

##### 2-5. Ignition Lever

The ignition lever (6, fig. 1-2) is located on the opposite side of the ignition safety lever (7). The ignition lever ignites each match individually as required. Before the ignition lever can be depressed to ignite each match, the ignition safety lever must be depressed.

##### 2-6. Coupling Plug

A coupling plug (8, fig. 1-5) is not attached to the equipment. It is a loose part and stowed in the packing chest when not in use. The coupling plug is used as a plug for the open end of the fuel delivery pipe when the hose assembly is disconnected from the quick-disconnect coupling half.

#### Section II. OPERATION UNDER USUAL CONDITIONS

##### 2-7. General

The trained gunner (FM 20-33) receives the flamethrower with the fuel tanks filled and the pressure tank pressurized. He also receives a can with two ignition cylinders. The gun and the hose are connected. The hose is usually connected to the fuel tank.

##### 2-8. Preparing Flamethrower for Use

The operator must perform the following operations to prepare the flamethrower for use:

a. Close the pressure tank valve by turning the valve handle (6, fig. 1-5) clockwise.

b. Perform this step if the hose assembly is not connected to the fuel tank delivery pipe coupling.

(1) Stand the tanks upright.

(2) Open both tank bleeder valves (3) and vent the pressurized air. Close both bleeder valves after the hissing noise stops.

(3) Lay the tanks in a horizontal position with the fuel delivery pipe (9) on the top side. Allow 2 minutes for the fuel in the tanks to settle to the bottom.

#### WARNING

To prevent injury to personnel, stand to

*c. Firing Position.* The M2A1-7 flamethrower can be fired by the gunner (FM 20-33) from a standing, kneeling, or prone position.

#### NOTE

To effectively disperse the fuel from the fuel tanks, the tops of the fuel tanks should be elevated higher than the bottom or outlet end of the fuel tank.

*d. Holding the Gun.* Grasp the valve grip with the right hand, with the palm of the hand on the valve safety lever (3, fig. 1-2) and the fingers curled around the valve lever assembly (4). Grasp the ignition grip with the left hand, with the palm of the hand on the ignition safety lever assembly (7) and the fingers curled around the ignition lever assembly (6).

*e. Aiming.*

#### WARNING

To prevent burn casualties keep the gun pointed away from friendly personnel at all times and never face the front of the gun.

There are no sights on the gun. Aim the gun in the direction of the target where the flame is required. Adjust for drift of the flaming rod if operating in strong winds.

*f. Firing.*

#### WARNING

Release the waist straps before firing to facilitate emergency disposal of the flamethrower during firing.

The flamethrower can be fired in one continuous burst that will last for approximately 6 seconds. It can also be fired in short bursts. The flamethrower gives best results when the temperature is above 30° F. To fire the flamethrower, proceed as follows:

- (1) Hold the gun by the barrel in the left hand.
- (2) Using the right hand, turn the pressure tank valve handle counterclockwise. The flamethrower is now ready for firing.
- (3) With the palm of the left hand rapidly squeeze the ignition safety lever assembly; at the same time, with fingers, rapidly squeeze the igni-

tion lever assembly and hold firmly. This should ignite one match in the ignition cylinder. If the match does not ignite, repeat the operation. Once lit, the match ignites the incendiary pellet that will burn for 8 to 12 seconds.

(4) With the palm of the right hand, rapidly squeeze the valve assembly; at the same time, with the fingers, rapidly squeeze the valve lever assembly and hold firmly. This will propel the fuel from the gun, ignited by the incendiary pellet. The right hand controls the fuel flow either as one continuous burst or several short bursts. By pressing and releasing the valve lever the gun can be fired at any time while an incendiary pellet is ignited.

(5) Release the valve lever to stop the fuel flow.

*g. During Firing.* It may be necessary during a flamethrower mission to replace the expended ignition cylinder. Replace and install the ignition cylinder as described in paragraph 2-10.

### 2-12. After-Firing Procedure

Perform the following steps after firing operations have been completed:

*a.* Point the gun at the ground. Press the gun valve safety lever (3, fig. 1-2) and lever assembly (4) to dispose of the fuel and vent the pressurized air.

*b.* Open the bleeder valves (3, fig. 1-5) on the filler caps.

#### WARNING

To prevent burns, protect the hands before handling the nozzle shield after firing.

*c.* Point the gun at the ground. Depress the shield latch (fig. 1-3) and allow the nozzle and ignition cylinder to drop from the gun.

#### NOTE

The officer in charge will decide whether to save the partly used ignition cylinder for future use or dispose of them.

*d.* Screw the nozzle shield back on the gun.

*e.* Close the valve on the pressure tank by turning the valve handle (6, fig. 1-5) clockwise.

### Section III. OPERATION UNDER UNUSUAL CONDITIONS

#### 2-13. Climatic Extremes

*a. Heat.* Heat has no appreciable effect on the flamethrower.

*b. Cold.* At temperatures below 30° F, it may be necessary to ignite two or more matches in the ignition cylinder to ignite the fuel. Ignite additional matches by resqueezing the ignition safety lever assembly and then the ignition lever.

#### 4-14. High or Variable Winds

##### WARNING

During firing the gunner must be alert against head winds that may blow the flame back on him.

High winds, cross winds, or variable winds will break up the flame rod and shorten the range. The gunner must compensate for the high and variable winds to maintain accuracy.

#### 2-15. Snow or Rain

##### CAUTION

Care must be taken to keep snow, mud, or ice out of the nozzle and working parts of the gun to prevent a malfunction.

The flamethrower can be fired in snow or rain or after brief immersion in water.

## CHAPTER 3

### OPERATOR'S MAINTENANCE INSTRUCTIONS

#### Section I. INSPECTION

##### 3-1. General

The gunner is responsible for specific regular inspection services to insure that the equipment operates properly and to lessen the probability of mechanical failure.

##### 3-2. Before-Operation Inspection

The gunner must perform the following inspec-

tions before using the flamethrower. Report all defects to organizational maintenance personnel.

a. Turn the valve handle on the pressure tank clockwise to stop the flow of pressurized air.

b. Operate the ignition safety lever assembly (7, fig. 1-2) and ignition lever assembly (6).

#### Section II. PREVENTIVE MAINTENANCE CHECKS AND SERVICES

##### 3-3. Purpose

The preventive maintenance checks and services (table 3-1) provide the operator with a list of maintenance services which must be performed at the intervals prescribed. Use the list to make sure that all authorized maintenance is accomplished. If corrective action is not authorized at operator's level, report equipment defects to organizational maintenance personnel.

##### 3-4. Explanation of Columns

A number under before- or after-operation in the Interval and Sequence No. column indicates that the services opposite the number must be performed in numerical sequence at the prescribed time. The time required to perform all the checks and services for each interval is shown in the work time column. These times are given in hours and tenths.

*Table 3-1. Operator/Crew Preventive Maintenance Checks and Services*

B—Before Operation Time Required: .02			D—During Operation	A—After Operation Time Required: .01	
Interval and Sequence No.			ITEM TO BE INSPECTED/PROCEDURE		Work Time (MH)
B	D	A			
1			Air pressure tank and fuel tanks Turn the valve handle on the pressure tank clockwise as far as it will go to make sure that it is		0.1

B—Before Operation Time Required: .02			D—During Operation	A—After Operation Time Required: .01	
Interval and Sequence No.			ITEM TO BE INSPECTED/PROCEDURE		Work Time (MH)
B	D	A			
		2	closed (fig. 1-6). Position the fuel tanks on the gunner's back. Adjust straps. The straps should be adjusted until the bottom of the tanks rests against the small of the gunner's back for comfortable fit. The tanks should not shift around when the gunner changes position. <i>Gun</i> Squeeze the Ignition Safety Lever (fig. 1-2) and the Ignition Lever to see that they operate freely. When the ignition safety lever is depressed the ignition lever is free to depress. Squeeze the valve safety lever and the valve lever to see that they operate freely. When the valve safety lever is depressed, the valve lever is free to depress. Install an ignition cylinder by depressing the nozzle shield latch (fig. 1-3) and unscrew the nozzle shield. Place the ignition cylinder (fig. 2-1) on top of the spring case (7, fig. 2-1). Place the nozzle shield (fig. 1-3) over the ignition cylinder and engage the outer case pin in the nozzle shield slot. Screw the nozzle shield in place. Back off the nozzle shield until the		0.1

Table 3-1. Operator/Crew Preventive Maintenance Checks and Services—Continued

B—Before Operation Time Required: .02      D—During Operation      A—After Operation Time Required: .01

Interval and Sequence No.			ITEM TO BE INSPECTED/PROCEDURE	Work Time (MH)
B	D	A		
		4	shield latch is engaged by the notch in the nozzle shield. Squeeze the valve safety lever and valve lever until all pressure is released from the fuel tanks. Point the gun at the ground. Depress the nozzle latch and remove the nozzle	0.1

B—Before Operation Time Required: .02      D—During Operation      A—After Operation Time Required: .01

Interval and Sequence No.			ITEM TO BE INSPECTED/PROCEDURE	Work Time (MH)
B	D	A		
3		5	shield and the ignition cylinder. Screw the nozzle shield back on the gun. <i>Hose</i> Check the hose for damage and missing parts. Check the gasket (3, fig. 1-4) in the coupling body.	0.1

## CHAPTER 4

### ORGANIZATIONAL MAINTENANCE INSTRUCTIONS

#### Section I. SERVICE UPON RECEIPT OF MATERIAL

##### 4-1. General

The M2A1-7 flamethrower is issued in a pack-

ing chest (fig. 4-1). The tanks are packed in the bottom of the chest. The assembled gun and hose

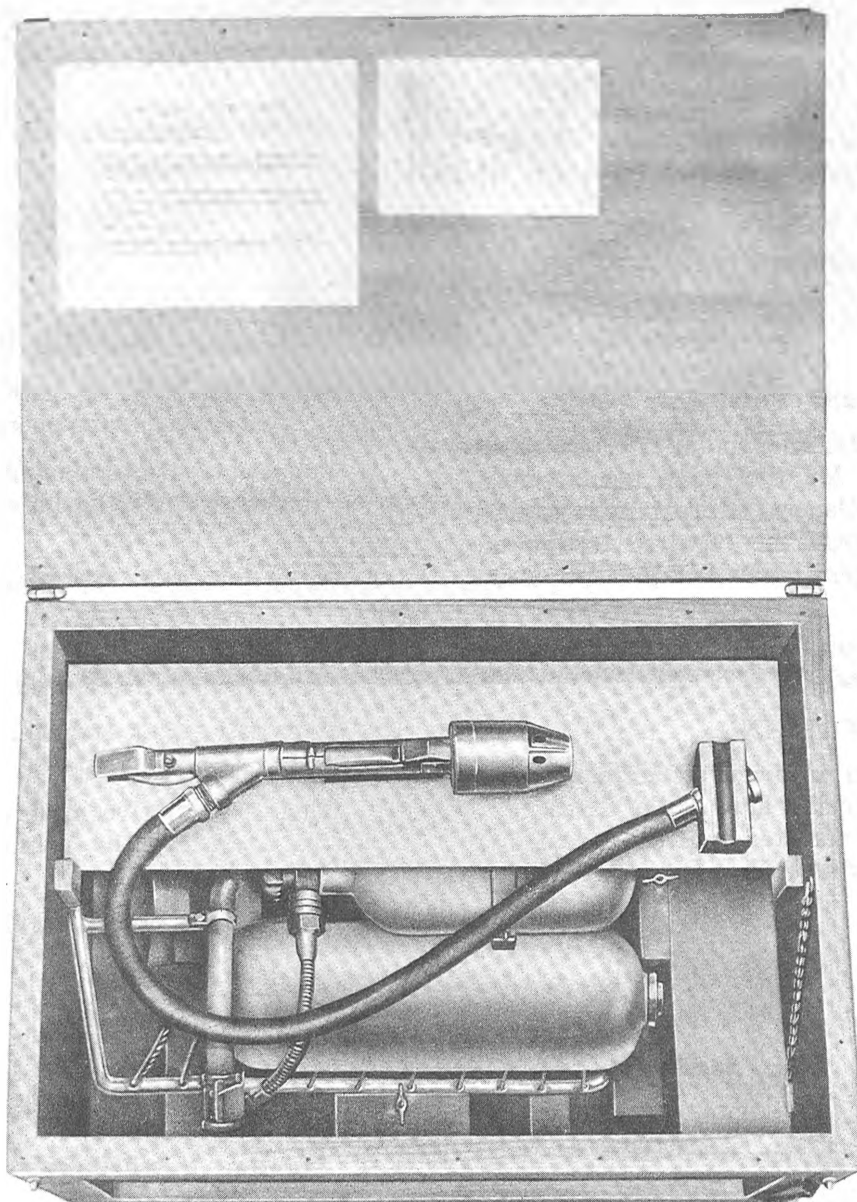

MU393413

Figure 4-1. M2A1-7 portable flamethrower in packing chest.

are fastened to a removable mounting board. Repacking instructions and a copy of the lubrication order (LO 3-1040-204-30) are attached to the inside of the cover.

#### 4-4. Unpacking and Inspection

Unpack the flamethrower as follows:

a. Cut the steel strapping and remove the screws securing the cover to the packing chest.

b. Unlock the hasps at the front of the packing chest.

c. Remove the assembled gun and hose assembly from the mounting board. Remove the mounting board. Release the fasteners and remove the tank assemblies.

d. Visually check to see that all equipment is serviceable. Report any maintenance beyond organizational maintenance to direct support maintenance personnel.

#### NOTE

The ignition cylinders (para 1-8) are not packed with the flamethrower. They are requisitioned separately.

#### 4-3. Hydrostatic and Volumetric Testing

Check the hydrostatic and volumetric test dates (para 6-1) on the M8 fuel hose, agent tanks, and pressure tank. General support maintenance personnel will perform the required testing on the M8 fuel hose, agent tanks, and pressure tank.

#### 4-4. Storage Life and Service Life— M8 Fuel Hose

#### WARNING

To prevent eye injuries or accidental fires, do not use the hose if the 2-year service life is exhausted or if the 5-year storage life is exhausted.

a. *Storage Life.*

Check the dates on the fuel hose. See that the hose is serviceable (para 6-2a).

b. *Service Life.*

Check the dates on the fuel hose. See that the hose is serviceable (para 6-2b).

#### 4-5. Removal of Protective Material

a. Drain preservative oil from the fuel tanks as follows:

(1) Open the bleeder valve (3, fig. 1-5) on the fuel tank.

(2) Remove the coupling plug (8) from the fuel tank outlet.

(3) Drain preservative oil from the tank.

(4) Replace the coupling plug on the fuel tank outlet.

b. Remove masking tape and protective material from the equipment.

c. Use drycleaning solvent (item 5, table 4-3) to remove preservative material from the equipment.

#### 4-6. Connecting Gun and Hose Assembly

If the hose assembly is disconnected from the gun, perform the following operations:

a. Apply antiseize compound (item 1, table 4-3) on the threads of the hose assembly (2, fig. 1-2).

b. Wrench tighten the hose coupling to the Y-inlet body on the gun.

#### 4-7. Air Pressure Tank and Fuel Tanks

The air pressure tank and fuel tanks are shipped completely assembled.

a. Remove protective material and drain preservative oil when the equipment is received (para 4-5).

b. Adjust the pressure regulator (para 5-14).

## Section II. PAINTING AND LUBRICATING

#### 4-8. General

Organizational maintenance personnel are authorized to retouch paint on the M2A1-7 flamethrower.

#### 4-9. Painting Instructions

a. *Preparation of Surface.* Apply masking tape (item 2, Table 4-3) over the pipe threads, openings, and all surfaces that are not to be painted.

*b. Primer.* Prime all worn and scratched surfaces with one coat of zinc chromate primer (item 3, Table 4-3).

*c. Exterior Surfaces.* Touch up the exterior surfaces of the flamethrower with two coats of olive drab (item 4, Table 4-3).

### Section III. SERVICING

#### 4-11. Filling Fuel Tanks

Organizational maintenance personnel are responsible for filling the fuel tanks.

*a.* Obtain prepared flamethrower fuel for the flamethrower (TM 3-366) fuel tanks.

*b.* Close the pressure tank valve by turning the valve handle (6, fig. 1-5) clockwise.

*c.* Open the bleeder valve (3).

*d.* Remove filling plugs (4).

#### NOTE

Fuel level in each fuel tank should be approximately 2 inches from the top of the fuel tank.

*e.* Fill the fuel tanks with fuel (TM 3-366) to specific levels.

*f.* Install filling plugs.

#### 4-12. Pressure Testing and Charging the Pressure Tank

*a. Pressure Testing.* Air pressure in the pressure tank must be checked as follows: Prior to use with the flamethrower and prior to recharging pressure tank, air pressure must be between 1,700 psi and 2,100 psi for maximum efficiency. Perform pressure test as specified in TM 3-1040-221-12 by using the M27 service kit.

*b. Charging Pressure Tanks.* Air pressure must be checked (*a* above) prior to charging pressure tanks. TM 3-1040-221-12 contains charging operations by using the M27 service kit. Air may be provided by either commercial cylinders or approved air compressors.

#### 4-13. Venting and Replacing Pressure Tank

#### WARNING

To prevent eye injuries, vent the pressurized air from the air pressure system before attempting any maintenance or modification to the pressure system.

#### 4-10. Lubricating Information

The lubrication order (LO 3-1040-204-30) is packed with the flamethrower in the packing chest. Lubrication of the flamethrower is performed by direct support maintenance personnel.

#### *a. Venting Operation.*

(1) Close (clockwise) pressure tank valve with valve handle (6, fig. 1-5).

(2) Open both bleeder valves (3) to vent air in fuel tanks.

#### *b. Removal.*

(1) Place the tanks in a horizontal position with pressure tank on top side.

(2) Remove the retain wingnut (7, fig. 4-2), eyelet (4), and clamp (5).

(3) Open (counterclockwise) pressure tank valve with handle. (6). After venting pressurized air, close pressure tank valve.

(4) Disconnect hinged tank clamp (12, fig. 1-5) by completely loosening wingnut.

#### CAUTION

Exercise care when disconnecting the pressure tank coupling plug from the pressure regulator quick-disconnect coupling half to prevent damage to the tube.

(5) Disconnect the quick-disconnect coupling half (3, fig. 4-2) from the coupling plug (9).

(6) Remove and retain the pressure tank and valve assembly.

#### *c. Installation.*

(1) Place the fuel tanks in a horizontal position with the quick-disconnect coupling half facing up.

#### NOTE

Check to see that the preformed packing in the quick-disconnect coupling half is installed and serviceable.

(2) Aline and connect the pressure tank coupling plug (9) to the pressure regulator quick-disconnect coupling half (3).

(3) Test to see that the coupling plug is engaged and locked in the quick-disconnect coupling half.

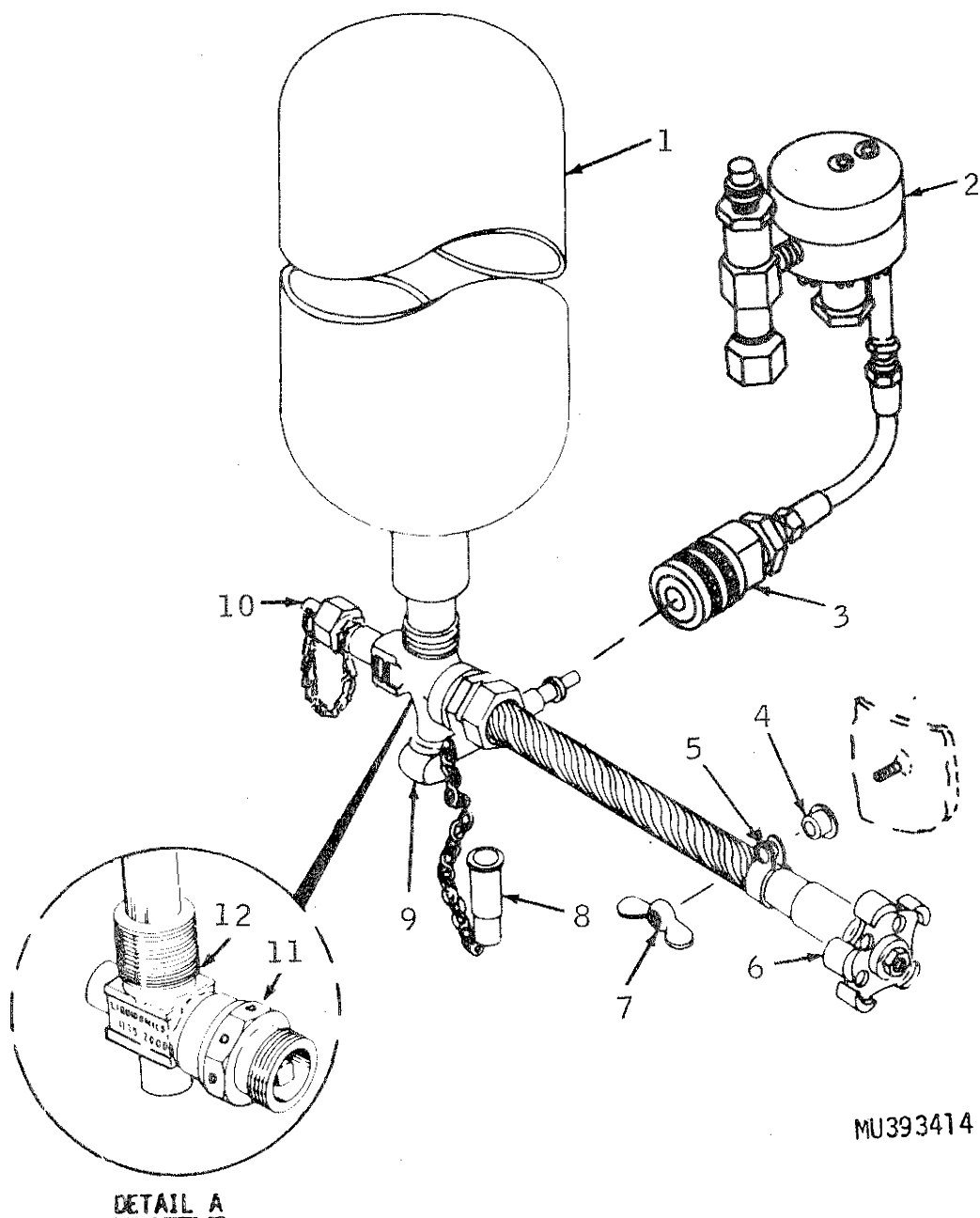

MU393414

- |                                  |           |                |
|----------------------------------|-----------|----------------|
| 1 Pressure tank                  | 5 Clamp   | 9 Plug         |
| 2 Pressure regulator             | 6 Handle  | 10 Check valve |
| 3 Quick-disconnect coupling half | 7 Wingnut | 11 Spool       |
| 4 Eyelet                         | 8 Cap     | 12 Valve body  |

Figure 4-2. Pressure tank and valve assembly.

ling half. The knurled ring on the quick-disconnect coupling half should not slide freely when properly connected.

(4) Close the hinged tank clamp (12, fig. 1-5) around the pressure tank and fasten the attached wingnut.

(5) Fasten the valve shaft to the boss on the agent tank with the clamp (5, fig. 4-2), eyelet (4), and wingnut (7).

**4-14. Installing Ignition Cylinders**

Install ignition cylinder (para 2-20).

## Section IV. PREVENTIVE MAINTENANCE CHECKS AND SERVICES

### 4-15. General

The purpose of preventive maintenance checks and services is to detect the first signs of failure in the M2A1-7 flamethrower and to insure that appropriate corrective action is taken before time-consuming repairs and replacement are required.

### 4-16. Before Issuing Flamethrower

Before issuing the flamethrower to the operator for use, perform the following visual inspections:

#### a. Gun.

(1) Remove nozzle shield (fig. 1-3) from the gun.

(2) Check spring case (7, fig. 2-2) for any damage.

(3) Check threads on nozzle shield and gun for damage.

(4) Install nozzle shield on gun.

(5) Squeeze the ignition safety lever and the ignition lever to see that they operate freely.

(6) Squeeze the valve safety lever and the valve lever to see that they operate freely.

(7) Check entire gun for any missing screws.

#### b. Hose Assembly.

(1) Check the hose (4, fig. 1-4) for cuts, frays, or any other damage.

(2) Check the coupling (5) for possible damage.

(3) Check the hydrostatic date on the hose assembly (para 6-1a).

(4) Check to see that the 5-year storage life (para 6-2a) and the 2-year service life (para 6-2b) is not exceeded.

#### c. Air Pressure Tank and Fuel Tanks.

(1) Place the fuel tanks in an upright position and close the pressure tank valve (11, fig. 1-5) by turning the valve handle (6) clockwise as far as it will go.

(2) Open the bleeder valve (3) on each filling plug to release any residual pressure. When hissing stops the pressure is released.

(3) Remove the filling plugs (4) and make sure the preformed packing is in place and serviceable.

(4) Install filling plugs.

(5) Check hydrostatic and volumetric test dates (para 6-1b) on the aluminum band attached to the diffusion pipe (fig. 1-7).

(6) Turn the valve handle (6, fig. 1-5) clockwise and counterclockwise to make sure the valve operates freely.

(7) Check hydrostatic and volumetric test dates (para 6-1c) on the aluminum band on the neck of the pressure tank.

(8) Check to see that the dust cap and check valve cap are present and serviceable.

(9) Check hinged clamp (fig. 1-7) and wing-nut for damage.

(10) Lay the flamethrower on a flat surface with the backpack facing down. Visually check to see that the disk in the safety head (fig. 1-7) is not ruptured.

(11) Support the regulator tube assembly (fig. 1-7) with the left hand. With the right hand check the tightness of the connection of the regulator tube socket and the plug on the high pressure valve by a firm pull on the plug.

(12) Check the frame for breaks, cracks, and missing nuts and bolts.

(13) Turn the flamethrower on its side so the quick-disconnect coupling lock (7, fig. 1-5) is turned up.

(14) Lift the coupling lock (1, fig. 1-4) and open the locking cams (6).

(15) Remove the coupling plug (8, fig. 1-5) and check to see that the rubber gasket (3, fig. 1-4) is present and serviceable.

(16) Install coupling plug, close locking cams, and lock coupling lock.

(17) Check carrier pack, cords, and straps for cuts, tears, or deterioration.

(18) Check all buckles and snaps to see that they are serviceable.

### 4-17. After-Operation Services

Upon receipt of a flamethrower that has been used to perform a mission, the following operations must be performed:

a. Check to see that the after-operation services have been performed by the operator (para 2-12).

b. Remove the filling plugs (4, fig. 1-5).

c. Disconnect the fuel hose from the tanks and drain any remaining residual fuel from the tanks and hose.

- d. Install the fuel hose.
- e. Fill the fuel tanks with diesel oil to approximately 2 inches from the top of the tank.
- f. Install the filling plugs and hand tighten.
- g. Shake the tanks to agitate the diesel oil.

**NOTE**

Tanks with gun and hose attached should stand for several hours, if possible.

- h. Remove the nozzle shield (fig. 1-3).
- i. Remove one of the filling plugs (4, fig. 1-5).

**NOTE**

Retain the diesel oil if more than one flamethrower is to be cleaned. If the diesel oil is not retained, dispose of as waste fuel.

- j. Squeeze the valve safety lever (3, fig. 1-2) and valve lever (4) and drain the tanks through the hose and gun.
- k. Disconnect the fuel hose from the tanks and completely drain the gun, hose, and fuel tanks.

l. Install the nozzle shield on the gun.

m. Install filling plug on tank.

n. Install coupling plug (8, fig. 1-5) in the quick-disconnect coupling.

o. Wipe the gun and hose with a clean cloth to remove any oil that may have been spilled during cleaning operation.

p. Clean the carrier pack with a stiff brush. Do not use soap and water which will cause fading and shrinking.

**4-18. Repacking Flamethrower**

a. Check to see that the after-operation services (para 4-17) have been performed.

b. Repack and secure the flamethrower in the packing chest (fig. 4-1).

c. Place the manual and a copy of the lubrication order in the packing chest.

d. Close lid and latches. Install screws through lid, and band with two steel straps if necessary.

**4-19. Preventive Maintenance Checks and Services**

a. *Purpose.* The preventive maintenance checks and services (Table 4-1) provide organizational maintenance personnel with a list of maintenance services which must be performed at the intervals prescribed. Use the list to make sure that all required maintenance is accomplished. If corrective action is not authorized at organizational level, report equipment failures to direct support maintenance personnel.

b. *Explanation of Columns.* A number under before issuing or after operation in the Interval and Sequence No. column indicates that the service opposite the number must be performed in the numerical sequence and at the prescribed interval. The time required to perform all the checks and services for each interval is shown in the work time column. These times are stated in hours and tenths.

Table 4-1. Organizational Preventive Maintenance Checks and Services

Interval and Sequence No.		ITEMS TO BE INSPECTED/PROCEDURE	Work Time (MH)
B	A		
1		GUN Inspect the gun for damage and missing parts. Check the operation of the gun (para 4-16a).	0.1
2		HOSE Check the hose for damage. Check the quick-disconnect coupling for missing parts (para 4-16b).	0.1
3		AIR PRESSURE TANK AND FUEL TANKS Check the tanks for dents and cracks. Check for missing parts (para 4-16c).	0.5
4		GUN, HOSE, AND TANK ASSEMBLIES Check to see that after operation checks and services of Table 3-1 have been performed by the operator. Perform after operation services (para 4-17).	1.0

**Section V. TROUBLESHOOTING**

**4-20. General**

Table 4-2 lists troubleshooting procedures for organizational maintenance personnel.

**4-21. Troubleshooting**

Each malfunction is followed by probable causes and corrective actions that can be taken to cor-

rect the malfunction. Report all malfunctions beyond the scope of organizational maintenance to direct support maintenance personnel.

Table 4-2. Troubleshooting

Item No.	Malfunction	Probable Cause	Corrective Action
1	Fuel leaks at hose quick-disconnect coupling and fuel tank outlet.	a. Quick-disconnect coupling not installed correctly on fuel outlet coupling. b. Preformed packing in quick-disconnect coupling missing or damaged. c. Defective quick-disconnect coupling.	Disconnect quick-disconnect coupling and connect correctly. Replace preformed packing (para 4-23). Refer to direct support maintenance.
2	Fuel leaks at hose coupling and Y-inlet body.	Hose coupling loose.	Refer to direct support maintenance.
3	Fuel leaks at filling plug.	a. Filling plug loose. b. Preformed packing missing or damaged.	Tighten filling plug (4-22). Replace preformed packing.
4	No discharge of fuel when valve safety lever and valve lever are depressed.	a. High pressure valve closed. b. High pressure tank empty.	Fully open high pressure valve (turn knob counterclockwise). Recharge high pressure tank (para 4-12).
5	Firing range less than 40 feet.	a. High pressure valve not fully open. b. Insufficient pressure in high-pressure tank.	Fully open high pressure valve (turn knob counter clockwise). Recharge high pressure tank (para 4-12).
6	Fuel does not ignite when discharged.	a. Ignition cylinder match did not light. b. Ignition cylinder defective.	Rotate cylinders to next match. Replace ignition cylinder (para 2-10).

Section VI. TANKS

4-22. Filling Plug Assembly and Preformed Packing

Organizational maintenance personnel are authorized to replace the filling plug assembly (1, fig. 4-3) and preformed packing (2). The following procedure is used for either filling plug assembly:

WARNING

To prevent eye injuries, vent the pressurized air from the air pressure system before attempting any maintenance or modification to the pressure system.

a. Removal.

- (1) Close the pressure tank valve (11, fig. 1-5) by turning the valve handle (6) clockwise.
- (2) Open the bleeder valve (3) to vent the pressurized air in the system.
- (3) Remove the filling plug assembly (1, fig. 4-3).
- (4) Remove preformed packing (2).

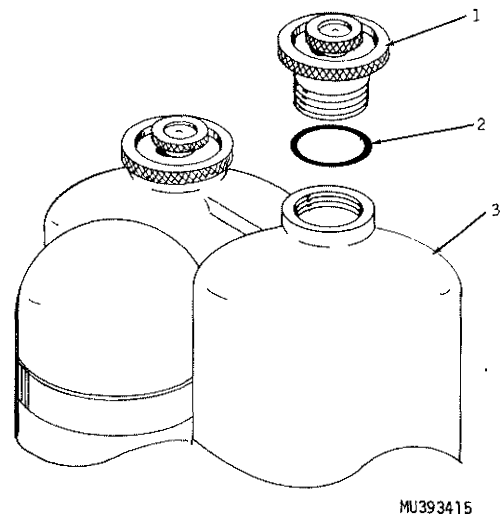

1 Filling plug  
2 Preformed packing  
3 Fuel tank  
4 Bleeder valve

Figure 4-3. Filling plug and preformed packing requirement.

b. Installation.

- (1) Install preformed packing (2).
- (2) Install filling plug assembly (1).
- (3) Close the bleeder valves.

4-23. Coupling Plug and Gasket

Organizational maintenance personnel are authorized to replace the coupling plug (8, fig. 1-5) and rubber gasket (3, fig. 1-4).

a. Removal.

- (1) Close the pressure tank valve (11, fig. 1-5) by turning the valve handle (6) clockwise.
- (2) Open the bleeder valve (3) to vent the pressurized air in the system.

- (3) Open the coupling lock (1, fig. 1-4), coupling cams (6) and remove coupling plug and rubber gasket.

b. Installation.

- (1) Install rubber gasket and coupling plug.
- (2) Close coupling cams and coupling lock.
- (3) Close the bleeder valves.

4-24. Pack Carrier

Organizational maintenance personnel are authorized to replace the pack carrier (5, fig. 4-4), straps, and cotton cord.

a. Pack Carrier. Remove and replace the pack carrier (5, fig. 4-4). Remove and replace cord if required.

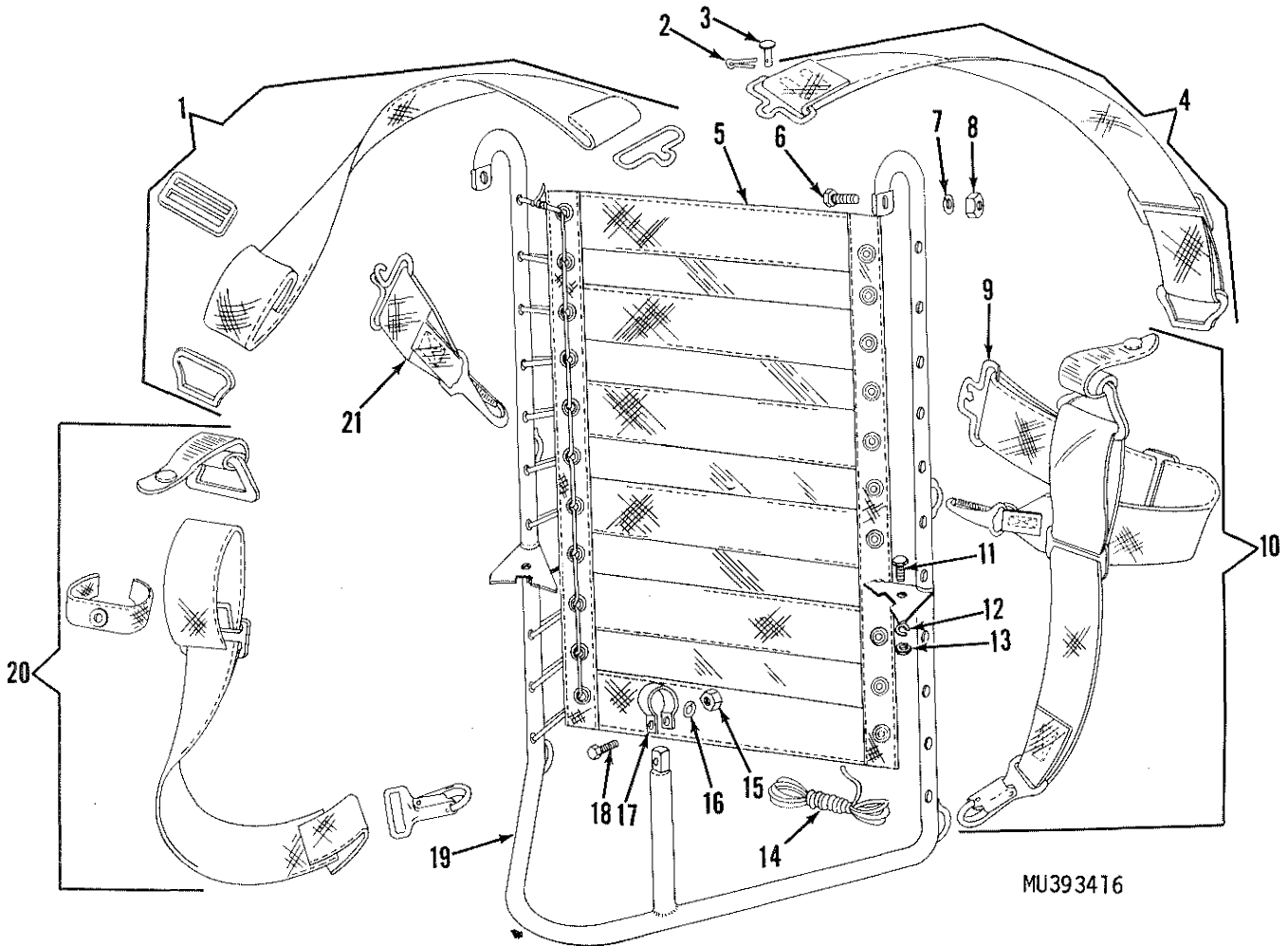

- |                       |                |                  |
|-----------------------|----------------|------------------|
| 1 Upper strap         | 8 Nut          | 15 Nut           |
| 2 Cotter pin          | 9 Long strap   | 16 Lockwasher    |
| 3 Headed straight pin | 10 Lower strap | 17 Loop clamp    |
| 4 Upper strap         | 11 Capscrew    | 18 Capscrew      |
| 5 Pack carrier        | 12 Lockwasher  | 19 Carrier frame |
| 6 Capscrew            | 13 Nut         | 20 Lower strap   |
| 7 Washer              | 14 Cotton cord |                  |

Figure 4-4. Carrier section, exploded view.

*b. Strap Assemblies.* Remove and replace the strap assemblies (fig. 4-4). The strap assemblies contain buckles and fasteners for attachment to the frame and for adjustment.

#### 4-25. Pressure Tank and Valve Assembly

Organizational maintenance personnel are authorized to replace the pressure tank and valve assembly and attaching wingnut.

##### *a. Removal.*

(1) Vent the air from the air pressure system (para 4-13a).

(2) Remove the pressure tank and valve assembly (para 4-13b).

*b. Installation.* Install the pressure tank and valve assembly (para 4-13c).

#### 4-26. Expendable Items

*a.* Table 4-3 lists the expendable items required to properly maintain the portable flame-thrower.

*b.* A complete listing of expendable items is contained in Supply Bulletin 700-50.

*Table 4-3. Expendable Items*

Item No.	Nomenclature	FSN
1	Antiseize Compound	8030-209-8005
2	Masking Tape	7510-290-2024
3	Zinc Chromate Primer, Color T	8010-290-4247
4	Olive Drab Paint	8010-290-6648
5	Drycleaning solvent	6850-264-9039

## CHAPTER 5

### DIRECT SUPPORT MAINTENANCE INSTRUCTIONS

---

#### Section I. GUN

##### 5-1. General

The gun consists of the ignition section and the valve section. Two screws hold the sections together.

##### 5-2. Gun

Direct support maintenance personnel are authorized to replace the gun.

###### *a. Removal.*

- (1) Close pressure tank valve (11, fig. 1-5) by turning valve handle (6) clockwise.
- (2) Open bleeder valves (3).
- (3) Open the coupling lock (1, fig. 1-4) and coupling cams (6) and remove the hose assembly.
- (4) Disconnect the hose assembly (2, fig. 1-2) from the gun.

###### *b. Installation.*

- (1) Apply antiseize compound (1, table 1-4) on the hose assembly coupling threads.
- (2) Connect the hose assembly coupling to the gun.
- (3) Insert the quick-disconnect coupling half (5, fig. 1-4) in the coupling body (2).
- (4) Close the coupling cams (6) and coupling lock (1).

##### 5-3. Ignition Grip Assembly

Direct support maintenance personnel are authorized to replace the parts that make up the ignition section.

*a. Removal and Disassembly.* Remove and disassemble the ignition section as far as necessary to clean, lubricate, and replace parts.

- (1) Close the pressure tank valve (11, fig. 1-5) and open bleeder valves (3).
- (2) Loosen the four screws (17, fig. 5-1).

(3) Slide the valve section out of the ignition section.

(4) Remove the four screws (17) and the grip cover (16).

(5) Disengage and remove the safety lever (22) from the link (13).

(6) Disassemble the safety lever spring (21) from the safety lever (22) by removing screw (19) and lockwasher (20).

(7) With the thumb, press down on the link (13). Remove the lever assembly (15) and headless shoulder pin (18).

(8) Screw one of the removed screws (17) into the head of the pin (14). Remove the pin (14).

(9) Remove the link (13), pin assembly (28), washer (12), outer spring (10), and inner spring (11).

(10) To remove the head body (8), remove the snapping (9), screws (6), and lockwashers (7).

#### NOTE

The following step is performed if the nozzle shield latch (25) is unserviceable.

(11) Remove screw (27), nozzle shield latch (25), and spring (26).

*b. Lubricating.* During assembly, replace, clean, and lubricate the parts as required (LO 3-1040-204-30).

###### *c. Assembly.*

#### NOTE

The following step is performed if the nozzle shield latch (25) was removed in step (a 11) above.

(1) Locate the spring (26) and shield latch (25) in the grip assembly (23) slot. Install and

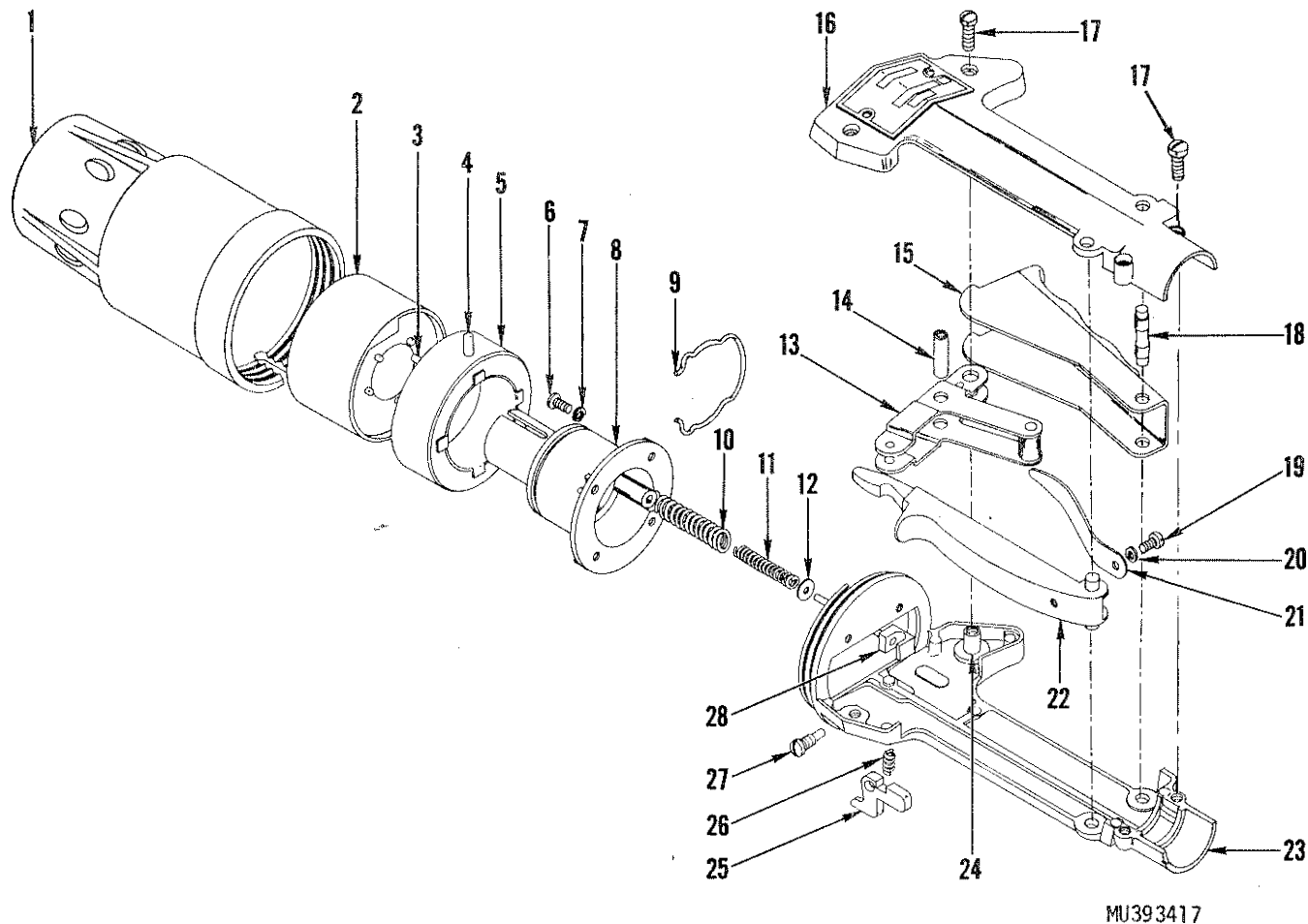

MU393417

- 1 Nozzle shield
- 2 Ignition cylinder
- 3 Inner case pin
- 4 Outer case pin
- 5 Spring case assembly
- 6 Screw
- 7 Lockwasher
- 8 Head body
- 9 Snapping
- 10 Outer spring

- 11 Inner spring
- 12 Washer
- 13 Link
- 14 Pin
- 15 Lever assembly
- 16 Grip cover
- 17 Screws
- 18 Shoulder pin
- 19 Screw

- 20 Lockwasher
- 21 Safety lever spring
- 22 Safety lever
- 23 Grip assembly
- 24 Pivot
- 25 Shield latch
- 26 Spring
- 27 Screw
- 28 Pin assembly

Figure 5-1. Ignition section of gun exploded view.

tighten screw (27). Check for proper operation of shield latch (25).

(2) Locate and position the shoulder on the head body (8) against the face of the grip assembly (23). Install lockwashers (7) and screws (6). Tighten screws.

(3) Install link (13) and pivot (24).

(4) Slide the washer (12), inner spring (11), and outer spring (10) on the pin assembly (28). Insert the needle end of the pin assembly (28) into the tube in the head body (8). Pass the U-shaped end of the pin assembly (28) through the link (13). See fig. 5-2.

(5) For ease of installation, temporarily install screw (17, fig. 5-1) into pin (14).

(6) Compress the springs (10 and 11) with the pin assembly (28) until the U-section is in line with center hole in the link assembly (fig. 5-3).

(7) Holding the screw, install the pin through the link. Remove the screw after the pin has been installed.

(8) Install the lever assembly (15, fig. 5-1) and shoulder pin (18) as follows. Slide the lever assembly (fig. 5-4) on the arm of the link and install the shoulder pin.

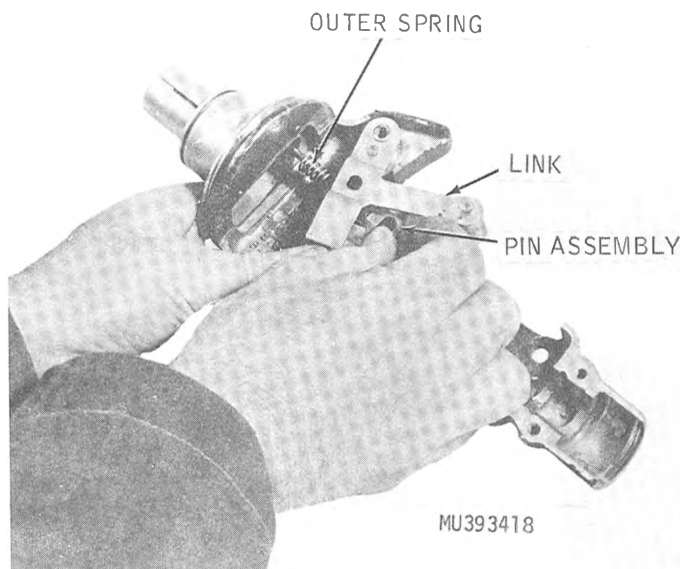

Figure 5-2. Installing ignition pin assembly.

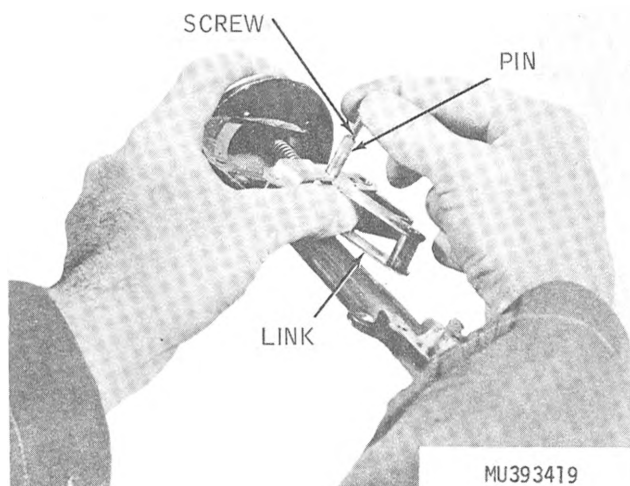

Figure 5-3. Inserting pin in ignition link.

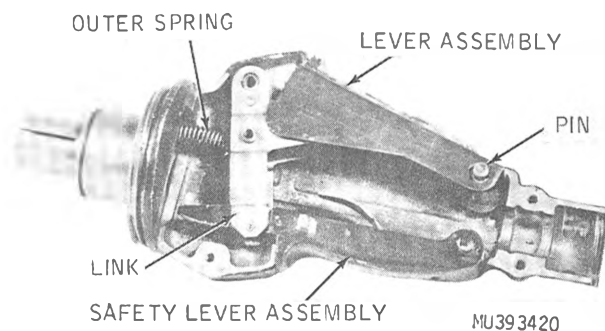

Figure 5-4. Installing ignition lever assembly and safety lever assembly.

(9) Connect the safety lever spring (21, fig. 5-1) to the safety lever (22) with lock-washer (20) and screw (19).

(10) Install the safety lever assembly (fig. 5-4).

(11) Lubricate parts as required.

(12) Install the grip cover (16, fig. 5-1) with four screws (17). Leave the two back screws loose.

(13) Face the inner-case pin (3) away from the head body (8). Install the spring case assembly (5) on the head body (8).

(14) Install the snapping (9) to hold the head body (8) in place.

(15) Install nozzle shield (1).

(16) Slide the valve section into the ignition section and tighten the screws (17).

#### 5-4. Valve Grip Assembly

Direct support maintenance personnel are authorized to replace the parts that make up the valve grip assembly.

*a. Removal and Disassembly.* Remove and disassemble the valve section as far as necessary to clean, lubricate, and replace parts.

(1) Close the pressure tank valve (11, fig. 1-5) and open bleeder valves (3).

(2) Loosen the two screws (5, fig. 1-2) and remove the valve section from the ignition section.

(3) Remove screws (19 and 20, fig. 5-5) from the grip cover (18). Remove cover (18).

(4) Hold the spring (16) and remove safety lever (15) and spring (16). If necessary, loosen the setscrew (8) and remove the bolt (9).

(5) Remove link assembly (7) and valve lever assembly (6).

(6) Insert a nail or rod into the holes in the pins (14 and 17). Remove bolt pins.

(7) Remove the post (5).

(8) Remove pin (10).

(9) Remove screw (3). Turn valve grip (13) counterclockwise and remove it. Remove valve retractor (4).

*b. Assembly.*

(1) Make sure the atomizer hole (1) is open and clean. If necessary, clean the atomizer hole with a piece of wire.

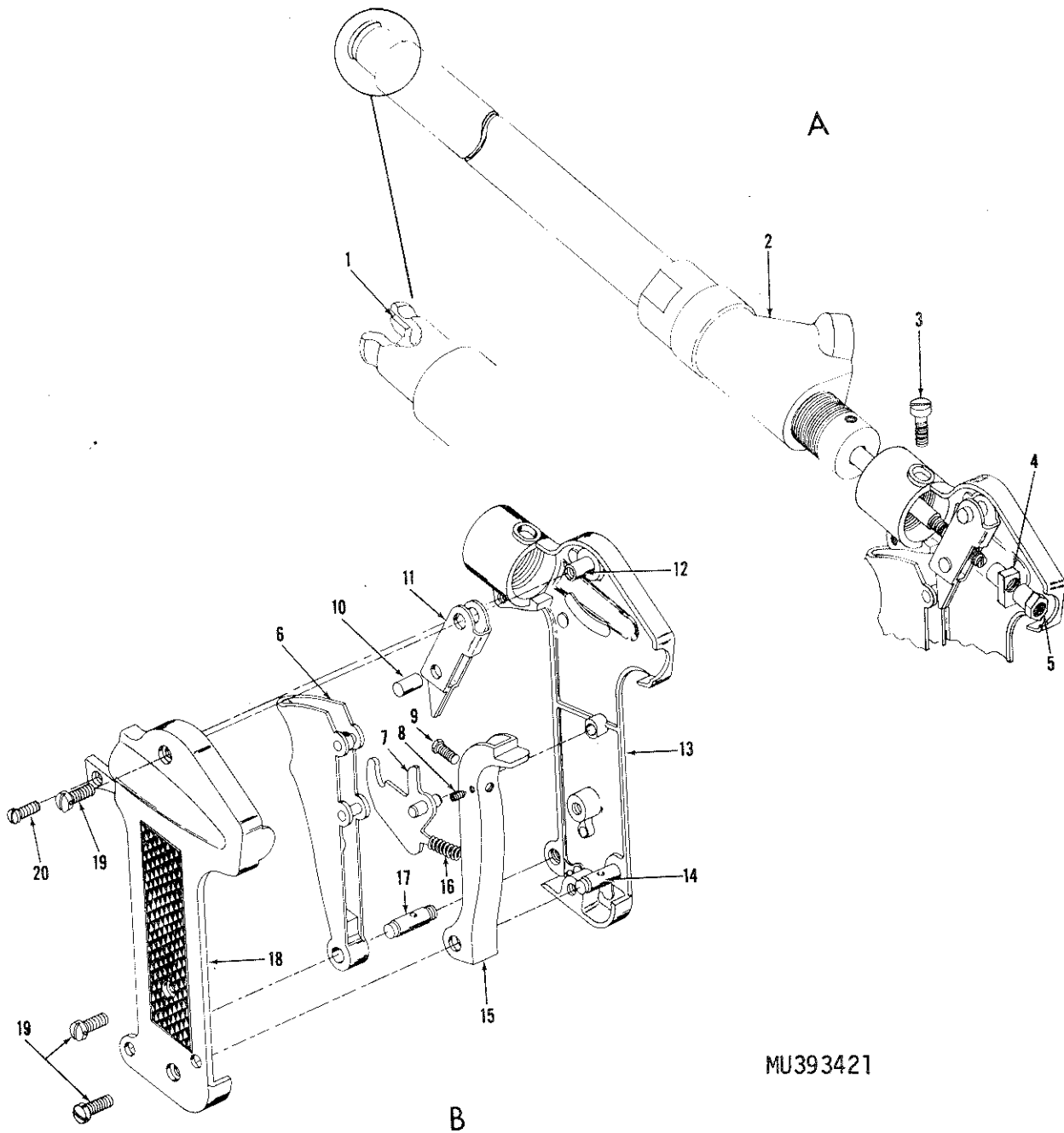

MU393421

- |                        |               |                 |
|------------------------|---------------|-----------------|
| 1 Atomizer hole        | 8 Setscrew    | 15 Safety lever |
| 2 Inlet body           | 9 Bolt        | 16 Spring       |
| 3 Screw                | 10 Pin        | 17 Pin          |
| 4 Valve retractor      | 11 Valve link | 18 Grip cover   |
| 5 Post                 | 12 Pivot      | 19 Screws       |
| 6 Valve lever assembly | 13 Valve grip | 20 Screw        |
| 7 Link assembly        | 14 Pin        |                 |

Figure 5-5. Valve section, exploded view.

(2) Screw the valve retractor (4) on the threaded shaft. Locate the valve retractor approximately in the center of the threaded portion of the shaft.

(3) Install the valve grip (13). Locate the

hole in the valve grip (13) with the hole in the inlet body. Install and tighten the screw (3).

(4) Install pins (14 and 17).

(5) Install valve link (11) and pivot toward the front of the gun. Insert pin (10). If

valve retractor (4) prevents the pin from being inserted, screw the valve retractor (4) toward the rear of the gun by turning the needle valve clockwise with a screwdriver.

(6) Install the post (5) with hexhead facing the rear of the gun. Do not tighten the post.

(7) If removed, loosely install setscrew (8) and bolt (9).

(8) Install valve lever assembly (6).

(9) Install link assembly (7). Install one end of the spring (16) on the link assembly (7).

(10) Install safety lever (15) and at the same time locate the open end of the spring into the recessed hole in the safety lever (15).

(11) If necessary, adjust the space between the bolt (9) and the safety link (7) to .035 ( $\pm .010$ ) inch. After adjustment has been made, lock bolt (9) with setscrew (8).

(12) Install the valve grip cover (18) and screws (19) and (20). Tighten screws.

(13) Slide the valve section into the ignition section and tighten both screws (5, fig. 1-2).

## Section II. HOSE

### 5-5. Fuel Hose

Direct support maintenance personnel are authorized to replace the M8 fuel hose.

*a. Check the Hydrostatic and Volumetric Test Dates.* Refer to paragraph 6-1.

*b. Check the Storage Life and Service Life Test Dates.* Refer to paragraph 6-2.

#### *c. Removal.*

(1) Close the pressure tank valve (11, fig. 1-5) and open the bleeder valves (3).

(2) Open the coupling lock (1, fig. 1-4) and coupling cams (6).

(3) Remove the hose assembly from the fuel delivery coupling.

(4) Remove the quick-disconnect coupling half (5) from the hose.

(5) Disconnect the hose assembly from the gun.

#### *d. Installation.*

(1) Apply antiseize compound on the hose coupling threads.

(2) Connect the hose assembly coupling to the gun inlet body.

(3) Install the quick-disconnect coupling half (5) on the hose.

(4) Insert the quick-disconnect coupling half in the coupling body (2).

(5) Close the coupling cams (6) and coupling lock (1).

### 5-6. Quick-Disconnect Coupling Half

Direct-support maintenance personnel are authorized to replace the quick-disconnect coupling half.

#### *a. Removal.*

(1) Close the pressure tank valve (11, fig. 1-5) and open the bleeder valves (3).

(2) Open the coupling lock (1, fig. 1-4) and coupling cams (6).

(3) Remove the hose assembly from the fuel delivery coupling.

(4) Remove the quick-disconnect coupling half (5) from the hose.

#### *b. Installation.*

(1) Apply antiseize compound on the hose coupling threads.

(2) Install the quick-disconnect coupling half (5) on the hose.

(3) Insert the quick-disconnect coupling half in the coupling body (2).

(4) Close the coupling cams (6) and coupling lock (1).

## Section III. TANKS

### 5-7. Fuel Tanks

Direct support maintenance personnel are authorized to replace the fuel tanks.

#### *a. Removal.*

(1) Close the pressure tank valve (11, fig. 1-5) and open the bleeder valves (3).

(2) Open the coupling lock (1, fig. 1-4), coupling cams (6), and remove the hose assembly.

(3) Remove the pressure tank and valve assembly (para 4-13a and b).

(4) Remove two filling plugs (4, fig. 1-5).

(5) Remove frame assembly (7, fig. 1-8) and attaching hardware.

(6) Remove the pressure regulator (fig. 1-7) by loosening the attaching tubing nut.

(7) Remove hinged clamp by removing rivet at hinge.

(8) Remove the quick-disconnect coupling.

*b. Installation.*

(1) Apply antiseize compound on the threads of the fuel delivery pipe (9, fig. 1-5) and install the quick-disconnect coupling.

(2) Install the hinged clamp (fig. 1-7) with rivet at hinge.

(3) Install pressure regulator (fig. 1-7) with the tubing nut on the diffusion pipe.

(4) Install frame assembly (7, fig. 1-8) with the attaching hardware.

(5) Install the filling plugs (4, fig. 1-5).

(6) Install the pressure tank and valve assembly (para 4-13c).

(7) Install the hose assembly and close the coupling cams and lock.

**5-8. Hinged Clamp**

Direct support maintenance personnel are authorized to replace the hinged clamp which holds the pressure tank.

*a. Removal.*

(1) Remove the pressure tank and valve assembly (para 4-13a and b).

(2) Remove hinged clamp (fig. 1-7) by removing rivet at hinge.

*b. Installation.*

(1) Install hinged clamp (fig. 1-7) with rivet at hinge.

(2) Install pressure tank and valve assembly (para 4-13c).

**5-9. Safety Head and Gasket**

Direct support maintenance personnel are authorized to replace the safety head and gasket.

*a. Removal.*

(1) Remove the pressure tank and valve assembly (para 4-13a and b).

(2) Remove the safety head (4, fig. 5-6).

(3) Remove the gasket (3).

*b. Installation.*

(1) Install the gasket (3) on the safety head (4).

(2) Install the safety head (4).

(3) Install the pressure tank and valve assembly (para 4-13c).

**5-10. Pressure Regulator and Safety Valve**

Direct support maintenance personnel are authorized to replace the pressure regulator (2, fig. 5-6) and safety valve (1).

*a. Removal.*

(1) Remove the pressure tank and valve assembly (para 4-13a and b).

(2) Loosen the tubing nut and remove the pressure regulator (2), tube assembly (5), and safety valve (1) as a unit.

(3) Remove the tube assembly (5) from the pressure regulator.

(4) Remove the safety valve (1) and tubing nipple from the regulator (2).

(5) Remove the safety head (4) from the safety valve.

*b. Installation.*

(1) Install the safety head (4) and gasket (3) on the safety valve (1).

(2) Install the tubing nipple and safety valve on the regulator.

(3) Install the tube assembly (5) on the pressure regulator.

(4) Install the regulator and attaching parts.

(5) Install the pressure tank and valve assembly (para 4-13c).

(6) Adjust the pressure regulator, if required (para 5-14).

**5-11. Regulator Tube Assembly**

Direct support maintenance personnel are authorized to replace the regulator tube assembly or its separate parts.

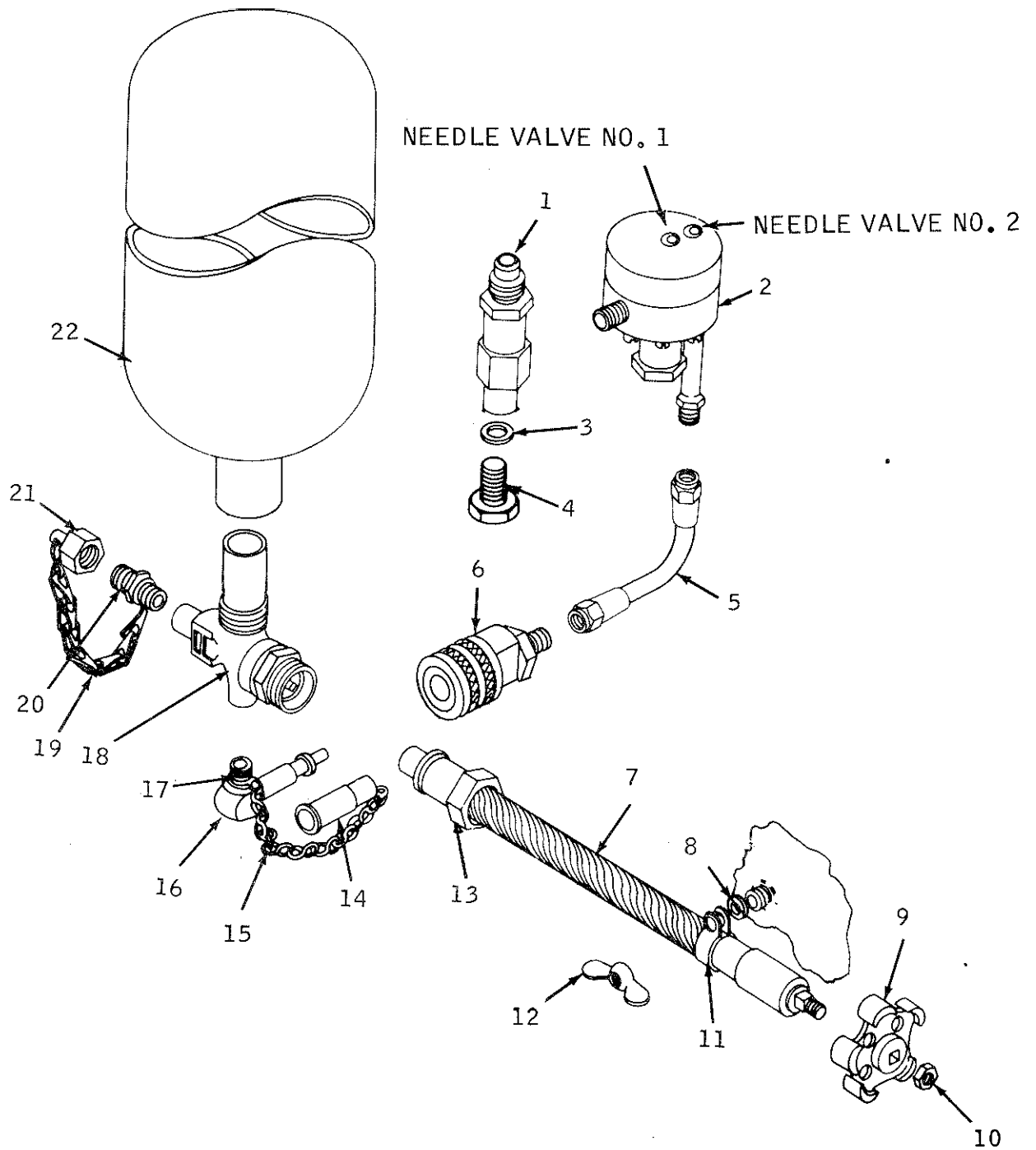

MU393422

- |                                  |                 |                        |
|----------------------------------|-----------------|------------------------|
| 1 Safety valve                   | 8 Eyelet        | 16 Screw               |
| 2 Pressure regulator             | 9 Valve handle  | 17 Plug assembly       |
| 3 Gasket                         | 10 Nut          | 18 Pressure tank valve |
| 4 Safety head                    | 11 Clamp        | 19 Chain               |
| 5 Tube assembly                  | 12 Wingnut      | 20 Check valve         |
| 6 Quick-disconnect coupling half | 13 Coupling nut | 21 Check valve cap     |
| 7 Valve shaft                    | 14 Plug cap     | 22 Pressure tank       |
|                                  | 15 Chain        |                        |

Figure 5-6. Pressure section, exploded view.

*a. Removal.*

(1) Remove the pressure tank and valve assembly (para 4-13a and b).

(2) Remove the quick-disconnect coupling half (6, fig. 5-6) and pressure regulator tube (5) by loosening the tubing nut at the pressure regulator.

(3) Remove the regular tube (5) from the quick disconnect coupling half (6).

*b. Installation.*

(1) Connect the regulator tube (5) and the quick-disconnect coupling half (6).

(2) Connect the regulator tube and quick-disconnect coupling half to the pressure regulator (2) with the tubing nut.

(3) Install the pressure tank and valve assembly (para 4-13c).

**5-12. Valve Shaft**

Direct support maintenance personnel are authorized to replace the valve shaft.

*a. Removal.*

(1) Remove wingnut (12, fig. 5-6).

(2) Remove valve shaft (7) by loosening coupling nut (13).

(3) Remove clamp (11) and handle (9) by removing nut (10).

*b. Installation.*

(1) Install handle (9) with nut (10).

(2) Connect the valve shaft (7) to the pressure tank valve (18) with coupling nut (13).

(3) Install clamp (11) and wingnut (12).

**5-13. Check Valve Assembly**

Direct support maintenance personnel are authorized to replace the check valve assembly (20, fig. 5-6).

*a. Removal.*

(1) Open the pressure tank valve by turning valve handle (6, fig. 1-5) counterclockwise.

(2) Open both bleeder valves (3) to vent all pressurized air.

(3) Remove the check valve assembly (20, fig. 5-6) from the pressure tank valve (18).

*b. Installation.* Install the check valve assembly (20).

**5-14. Adjusting Pressure Regulator**

Direct support maintenance personnel are au-

thorized to adjust the pressure regulator. Adjustment is performed upon receipt of an M2A1-7 flamethrower or when a pressure regulator has been replaced and if there is excessive breaking up of the fuel rod not caused by strong crosswinds or headwinds.

*a. Preparation for Adjusting.*

(1) Unlace the canvas pack carrier on one side to expose the pressure regulator.

(2) Close the pressure tank valve (18, fig. 5-6) by turning the valve handle (9) clockwise.

(3) Open the bleeder valve (4, fig. 4-3) on the fuel tanks to vent the pressurized air.

(4) Check the pressure in the pressure tanks (para 4-12). The pressure for testing purposes should be a minimum of 2,000 psi. Pressure tank removal and installation is performed according to paragraph 4-13.

*b. Adjusting Procedures.*

(1) Perform the operations in *a* above.

(2) Remove one filling plug (1, fig. 4-3). Hand tighten the other filling plug (1) and bleeder valve (4).

(3) Obtain a pressure gage from the M27 riot control service kit (TM 3-1040-221-12).

(4) Install and tighten the test pressure gage into the opening in the fuel tank (3).

(5) Using a socket head setscrew wrench, finger tighten needle valve No. 1 and needle valve No. 2 (fig. 5-6).

**NOTE**

If there is a needle valve on the side of the pressure regulator, check to see that the needle valve is tight.

**NOTE**

Needle valve No. 1 and No. 2 should not be removed; they are not interchangeable.

(6) Loosen needle valve No. 1 slowly; four complete turns to allow pressurized air to escape from the dome.

**NOTE**

Discharge of air is indicated by a hissing sound.

(7) After hissing noise ceases, close needle valve No. 1.

(8) Open the pressure tank valve slowly. If the gage indicates a rise in pressure, close the pressure tank valve immediately. A rise in

pressure indicates that the pressure regulator is defective.

(9) If the pressure regulator is defective, perform the following operations:

(a) Close the pressure tank valve.

(b) Open the bleeder valve to vent air pressure in the fuel tanks.

(c) Replace the pressure regulator (para 5-10).

(10) If the pressure gage indicates no rise in pressure, open needle valve No. 2 slowly about one-half turn. Air will escape at the needle valve.

(11) Open needle valve No. 1 very slowly until pressure gage indicates  $325 \pm 25$  psi, immediately close needle valve No. 1

(12) Close needle valve No. 2

(13) If pressure gage reading is less than 300 psi, repeat operations (10) and (11) above.

(14) If pressure gage reading is above 350 psi, close the pressure tank valve. Open the shut-off valve to vent pressurized air. Repeat operations (6) to (12) above.

(15) Close the pressure tank valve.

(16) Open the bleeder valve to vent the pressurized air.

(17) Check and test adjustment of pressure regulator (*c* below).

*c. Testing Pressure Regulator After Adjusting.*

(1) Close the shutoff valve.

(2) Slowly open the pressure tank valve and check the pressure gage. If the gage indicates a pressure between 300 and 350 psi, the adjustment is correct.

#### NOTE

If the pressure gage indicates a pressure below 300 psi or above 350 psi, refer to *b* above.

### 5-15. Carrier Frame

Direct support maintenance personnel are authorized to replace the carrier frame.

*a. Removal.*

(1) Remove the pack carrier (5, fig. 4-4) and all straps and attaching hardware from the carrier frame (19).

(2) Remove the carrier frame (19) and attaching hardware from the tank group.

*b. Installation.*

(1) Install the carrier frame (19) on the tank group with attaching hardware.

(2) Install the pack carrier (5), straps, cord, and attaching hardware on the carrier frame (19).

### 5-16. Packaging Chest

Direct support maintenance personnel are authorized to repair the packing chest (fig. 4-1). Use existing chest as a guide.

## CHAPTER 6

### GENERAL SUPPORT MAINTENANCE INSTRUCTIONS

#### Section I. TESTING AND SERVICING

##### 6-1. Hydrostatic and Volumetric Testing

General support maintenance personnel will perform the hydrostatic and volumetric testing (TM 3-1040-251-15) on the following equipment at the intervals specified. An aluminum strip is attached to the item showing the date the testing was performed.

- a. Perform the hydrostatic test on the hose assembly at least once every 6 months.
- b. Perform the hydrostatic test on the fuel tanks at least once every year; perform the volumetric test at least once every 4 years.
- c. Perform the hydrostatic and volumetric test on the air pressure tank at least once every 4 years.

##### 6-2. Storage Life and Service Life— M8 Hose Group

###### a. Storage Life.

#### WARNING

To prevent eye injuries or accidental fires, do not use the hose if the 2-year service life is exhausted or if the 5-year storage life is exhausted.

Storage life is 5 years from the date of manufacture which is stamped on the coupling at each end of the hoses.

###### b. Service Life.

Service life is 2 years from the date stamped directly under the manufacture date. This date is stamped by depot maintenance personnel prior to issuing the hose to using units. The service life is coded as follows: A letter represents the month of the year, and a number represents the year (i.e., A-7 is January 1967, and B-8 is February 1968).

##### 6-3. Preparing Flamethrower for Test

a. *General.* General support maintenance personnel are authorized to test the flamethrower

for possible fuel leaks. A test gage and adapter must be temporarily installed prior to test.

###### b. Disassembly.

- (1) Check to see that the high pressure valve is closed.
- (2) Open the bleeder valve (3, fig. 1-5) and remove the filling plug (4).

c. *Installation.* Install the fuel tank test gage from the M27 service kit into the fuel filling opening.

##### 6-4. Test Firing

a. *General.* Flamethrowers returned to general support maintenance must be thoroughly inspected, cleaned, and test fired. Test firing can be performed at a test range (AR 385-63) by using diesel fuel (para 6-4b) or diesel fuel oil (para 6-4c).

###### b. Using Diesel Fuel.

#### NOTE

Test fire the flamethrower at a suitable range (AR 385-63). If a suitable range is not available, test fire the flamethrower using diesel fuel oil (para c below).

- (1) Prepare flamethrower for test (para 6-3).
- (2) Fully charge the pressure tank (para 4-12).
- (3) Fill the fuel tanks with diesel fuel.
- (4) Connect the hose and gun assembly to the fuel tanks.
- (5) Open the high pressure valve.
- (6) Check the reading on the test gage. The gage should indicate a pressure between 300 and 350 psi.
- (7) Wait 5 minutes, and again check the reading on the test gage. If the pressure in-

creases 10 psi or more, replace the pressure regulator (para 5-10).

(8) Install ignition cylinder (para 2-10).

(9) Fire a burst of fuel for at least 3 seconds (para 2-11).

(10) Fifteen seconds after completing the firing, check the reading on the test gage.

(11) Wait 5 minutes, and again check the reading on the gage. If the pressure increases 10 psi or more, replace the pressure regulator (para 5-10).

(12) Check the connections on the pressure system for possible leaks. Use soapy water on all joints and connections.

(13) Remove the ignition cylinder.

(14) Check the needle valve assembly for possible fuel leaks. If required, adjust the needle valve assembly (para 6-5) or replace the barrel and inlet body (para 6-6).

(15) At completion of test, close the high pressure valve on the pressure tank.

(16) Open the bleeder valve (3, fig. 1-5) to release air pressure in the fuel tanks.

(17) Remove the test gage and replace it in the M27 service kit.

(18) Install the filling plug.

(19) Disconnect the hose assembly from the fuel tank outlet.

(20) Drain off the excess fuel and wipe the gun, hose, and tank sections with a clean dry cloth.

*c. Using Diesel Fuel Oil.* This procedure is followed if a suitable range (*a* above) is not available.

(1) Prepare the flamethrower for test (para 6-3).

(2) Fully charge the pressure tank (para 4-12).

(3) Fill the fuel tanks with diesel fuel oil.

(4) Connect the gun and hose to the fuel tanks.

(5) Open the high pressure valve.

(6) Check the reading on the test gage. The gage should indicate a pressure between 300 and 350 psi.

(7) Wait 5 minutes, and again check the reading on the gage. If the pressure increases 10 psi or more, replace the pressure regulator (para 5-10).

#### NOTE

Ignition cylinders are not used for firing the flamethrower when using diesel fuel oil.

(8) Fire a burst of fuel oil for at least 3 seconds (para 2-11).

(9) Fifteen seconds after completing the firing, check the reading on the test gage.

(10) Wait 5 minutes, and again check the reading on the gage. If the pressure increases 10 psi or more, replace the pressure regulator (para 5-10).

(11) Check the connections on the pressure system for possible leaks. Use soapy water on all joints and connections.

(12) Check the needle valve for possible fuel leaks. If required, adjust the needle valve assembly (para 6-5) or replace the barrel and inlet body (para 6-6).

(13) At completion of the test, close the high pressure valve.

(14) Open the bleeder valve (3, fig. 1-5) to release air pressure in the fuel tanks.

(15) Remove the test gage and replace it in the M27 service kit.

(16) Install the filling plug.

(17) Disconnect the hose from the fuel tanks.

(18) Drain off the excess fuel and wipe the gun, hose and tank section with a clean dry cloth.

## Section II. GUN

### 6-5. Needle Valve Assembly and Inlet Body

General support maintenance personnel are authorized to replace the inlet body and parts that make up the needle valve assembly.

*a. Description and Function.* The needle valve assembly (2, fig. 6-1) meters the flow of fuel

from the barrel assembly (1). The rear end of the needle valve assembly (2) is supported in a sleeve bearing (8), that fits into the inlet body (10). Preformed packing (7) are provided to prevent fuel from leaking into the valve grip assembly.

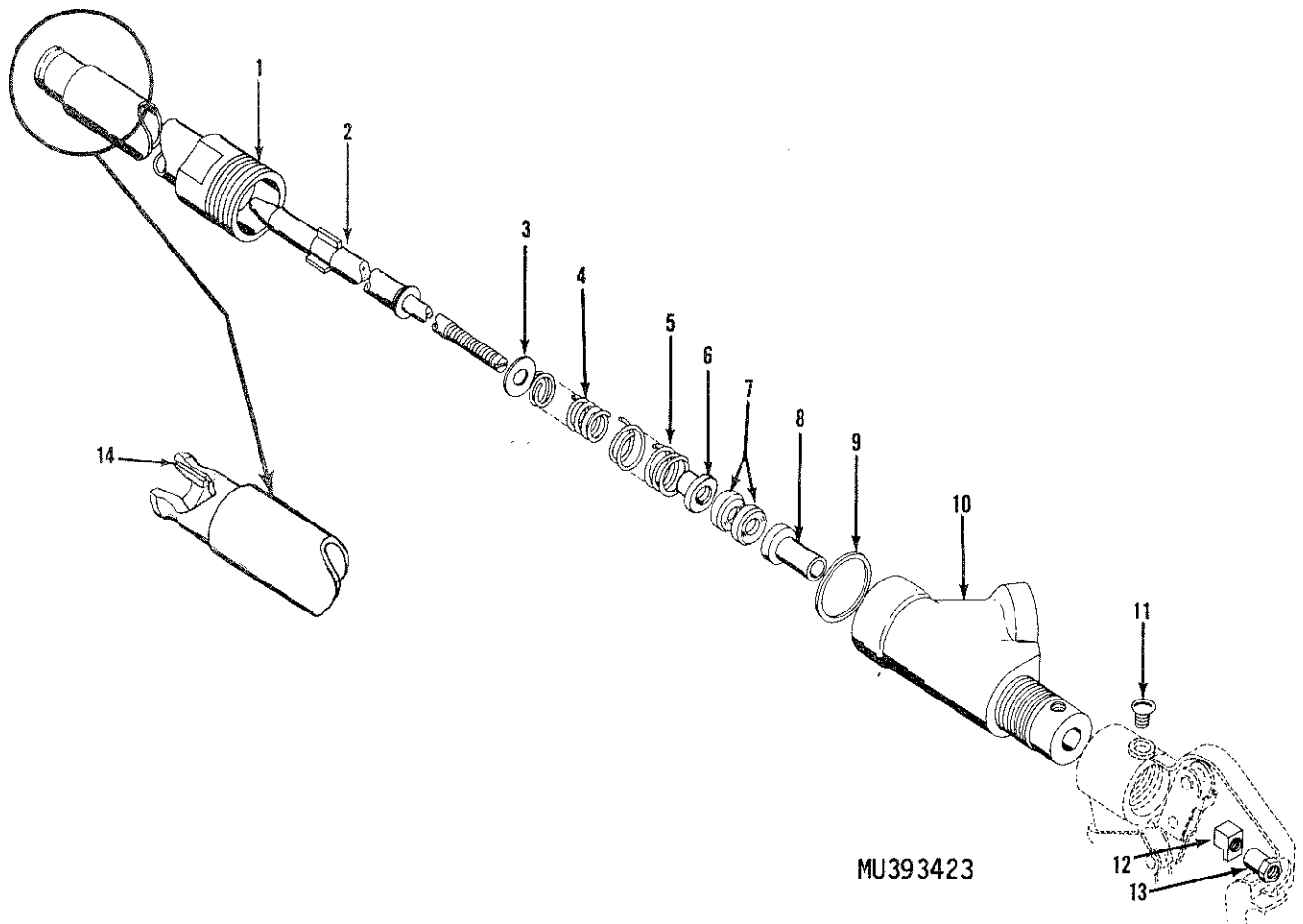

- |                         |                     |                    |
|-------------------------|---------------------|--------------------|
| 1 Barrel assembly       | 6 Packing retainer  | 11 Screw           |
| 2 Needle valve assembly | 7 Preformed packing | 12 Valve retractor |
| 3 Washer                | 8 Sleeve bearing    | 13 Sleeve nut      |
| 4 Valve inner spring    | 9 Sealing gasket    | 14 Atomizer hole   |
| 5 Valve outer spring    | 10 Inlet body       |                    |

Figure 6-1. Barrel-and-inlet body, exploded view.

*b. Disassembly.*

(1) Remove valve grip assembly (para 5-4).

(2) Screw the valve retractor (12) as far as it will go on the threads of the needle valve assembly (2).

(3) Secure the inlet body (10), in a vise, in such a way that the inlet body will not be damaged.

(4) Using a wrench, screw the barrel assembly (1) off the inlet body (10). Remove the barrel assembly.

(5) Position the point of the needle valve assembly (fig. 6-2) on a cushioned surface to avoid damage to the needle valve.

**WARNING**

To prevent injury to personnel, slowly

release the pressure on the inlet body to prevent the inlet body and springs under tension from flying off the needle valve.

(6) Push down on the inlet body with one hand. Hold the inlet body under tension, and unscrew the valve retractor from the needle valve. Carefully and slowly release the pressure on the inlet body.

(7) Remove the inlet body (10, fig. 6-1), sealing gasket (9), sleeve bearing (8), preformed packings (7), packing retainer (6), springs (4 and 5), and washer (3).

*c. Inspection.*

(1) Check the needle valve parts removed in *b* above for possible damage and wear.

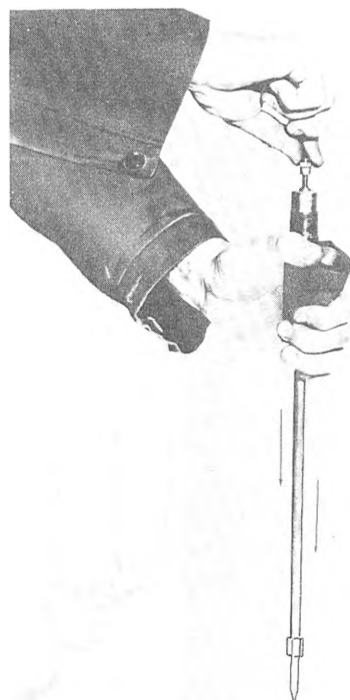

MU393424

Figure 6-2. Removing valve retractor.

(2) Check especially the sealing gasket (9), preformed packings (7), and packing retainer (6) for damage and deterioration.

*d. Servicing.* Servicing consists of cleaning all the parts of the needle valve assembly of any foreign accumulation.

*e. Assembly.*

(1) With the chamfer side of the packing retainer (6) facing away from the needle valve, place the packing retainer (6) on the needle valve.

(2) With the open side of the V on the preformed packing (7) facing the chamfer on the packing retainer (6), place the preformed packings on the needle valve assembly (2). Place the sleeve bearing (8) on the needle valve assembly (2).

(3) Push the needle valve assembly (2) with the installed parts into the inlet body (10) until the installed parts are seated properly.

**NOTE**

If the packing retainer or preformed packing should come out when the needle valve assembly is withdrawn, it may be necessary to hold the parts in place with a screwdriver, when withdrawing the needle valve assembly.

(4) Withdraw the needle valve assembly from the inlet body by turning it and pulling it slowly out of the inlet body (10).

(5) Place washer (3), inner spring (4), and outer spring (5) on the needle valve and insert these parts as a unit into the inlet body.

(6) Compress these parts by placing the needle valve assembly (2) on a cushioned surface and pushing down on the inlet body (10) permitting the needle valve assembly to come through the inlet body (fig. 6-2). Screw the valve retractor onto the threaded end of the needle valve as far as it can be turned with fingers.

(7) Install a new sealing gasket (9, fig. 6-1).

(8) Slide the barrel assembly (1) over the needle valve assembly and screw it into the inlet body.

(9) Tighten the barrel assembly (1).

(10) Unscrew the valve retractor (12) until it is at least two-thirds off the needle valve threads.

(11) Install the valve grip assembly (para 5-4).

(12) Prepare the flamethrower for test firing (para 6-3).

(13) Test fire the flamethrower (para 6-4).

## 6-6. Barrel Assembly

General support maintenance personnel are authorized to replace the barrel assembly.

### a. Removal.

(1) Remove the valve grip assembly (para 5-4).

(2) Screw the valve retractor (12, fig. 6-1) as far as it will go on the threads of the needle valve assembly (2).

(3) Secure the inlet body (10) in a vise, in such a way that the inlet body will not be damaged.

(4) Using a wrench, screw the barrel assembly (1) off of the inlet body (10).

### b. Inspection.

(1) Inspect the barrel (1) for possible damage. Check especially the threads on the barrel for damage.

(2) Clean the exposed end of the needle valve (2) of foreign material.

(3) Clean the atomizer hole (14) in the needle valve assembly (2), if required.

(4) Install the valve grip assembly (para 5-4).

### c. Assembly.

(1) Slide the barrel assembly (1) over the

needle valve assembly and screw it into the inlet body.

(2) Tighten the barrel (1).

(3) Unscrew the valve retractor (12) until it is at least two-thirds off the needle valve threads.

## 6-7. Needle Valve and Valve Barrel Lapping Procedure

a. Lapping the needle valve assembly (2, fig. 6-1) into the nozzle of the barrel assembly (1) is a general support maintenance responsibility.

b. Separate the needle valve and barrel assembly as an assembly unit from the valve section.

c. Overcome the spring tension and withdraw the needle valve assembly into the barrel assembly. Apply a valve-grinding compound (lapping compound) between the nozzle seat and the needle point contacting surfaces.

d. Permit the spring to force the end of the needle against the seat inside the nozzle.

e. Turn the needle valve until the contacting surface of the needle and seat make a tight connection when seated.

f. Reassemble and lubricate the gun group and test fire the weapon.

## Section III. FUEL

### 6-8. Quick-Disconnect Coupling Assembly

General support maintenance personnel are authorized to replace the quick-disconnect coupling assembly.

#### a. Removal.

(1) Close the pressure tank valve (11, fig. 1-5).

(2) Open the bleeder valves (3).

(3) Open the coupling lock (1, fig. 1-4), coupling cams (6), and remove the hose assembly.

(4) Remove the quick-disconnect coupling assembly (fig. 1-7).

#### b. Installation.

(1) Apply antiseize compound (item 1, Table 4-1) on the threads of the fuel delivery pipe (9, fig. 1-5).

(2) Install the quick-disconnect coupling assembly (fig. 1-7).

(3) Insert the hose coupling, close the coupling cams (6, fig. 1-4) and close the coupling lock (1).

(4) Close the bleeder valves (3, fig. 1-5).

## Section IV. PRESSURE

### 6-9. Pressure Tank Safety Valve and Plug Assembly

General support maintenance personnel are authorized to replace the pressure tank safety valve and plug assembly.

a. *Inspection.* Check the pressure tank valve for the following identification:

(1) The letter D must be stamped on the spool (11, fig. 4-2) in six places or on the valve

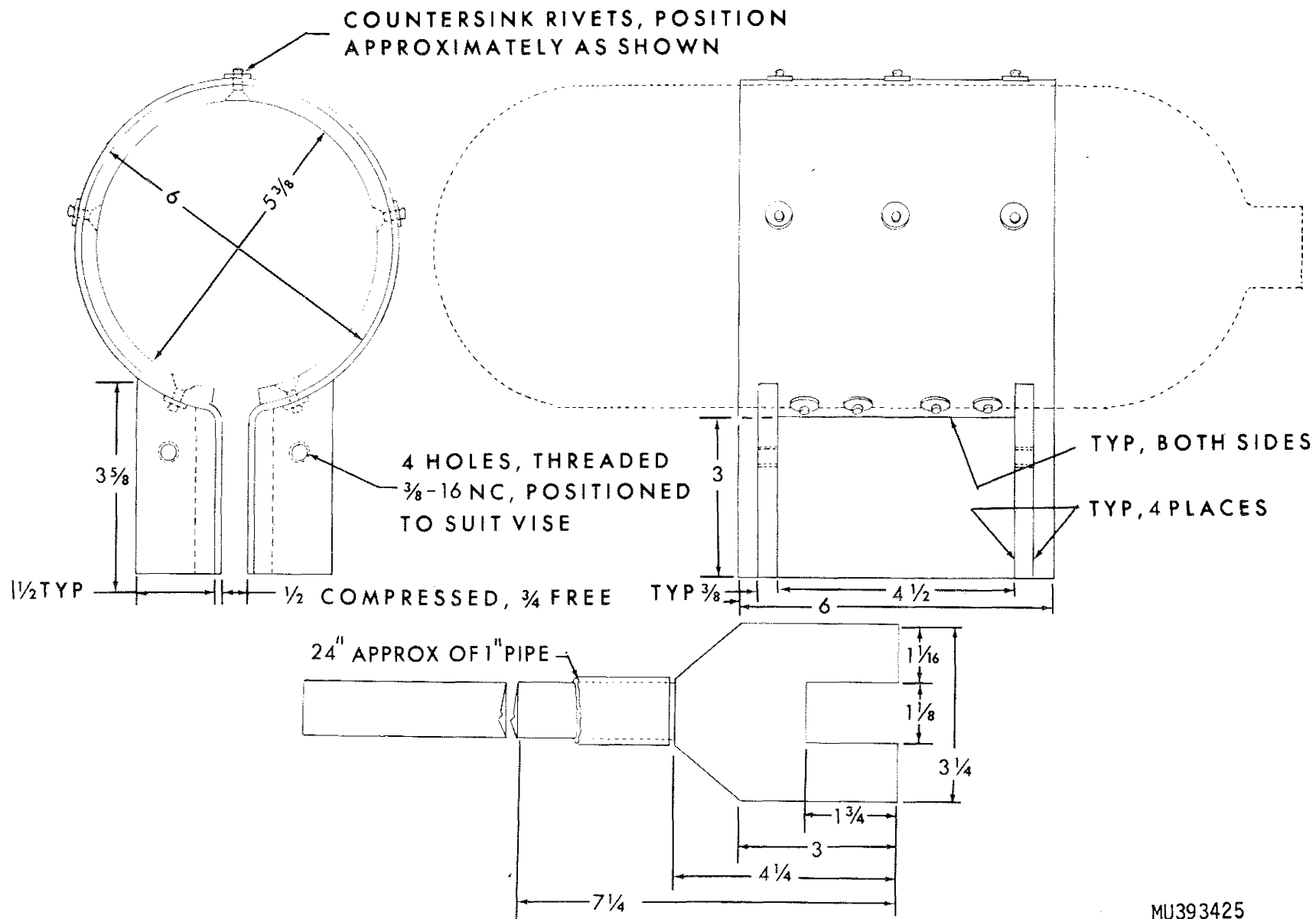

Figure 6-3. Holding device and valve wrench.

body (12). If the letter D appears on the spool or valve body, it is the authorized type of valve.

(2) If the spool or valve body are not identified properly ( (1) above), replace the valve body.

(3) Check the operation of the pressure tank valve (12) by turning the valve handle (6) clockwise and counterclockwise. The valve should operate with ease. Replace the valve if it is difficult to operate.

*b. Manufacture.* To prevent damage to the pressure tank, a locally fabricated valve wrench and holding device is recommended.

(1) *Valve wrench.* Select a block of steel 1 1/4 by 3 1/4 by 4 1/4 inches (fig. 6-3). Along the 3 1/4-inch surface, measure 1 1/16 inches in from one end and mark the surface. Measure 1 1/16 inches in from the other end and mark that surface also. Along the 4 1/4 inch surface, measure a depth of 1 3/4 inches in from the two 1 1/16 inch marked places. Cut out the 1 3/4 inch piece from the steel block. Measure 3 inches along the two sides of the 4 1/4 inch surface and mark the surfaces. Measure 1-inch in toward the center of the block from both ends along the uncut 3 1/4-

inch surface and mark the surfaces. Cut off the excess steel in the angles between the 3-inch marks and the 1-inch marks. Drill a hole in the steel block for a depth of about 1/2-inch to suit the inside diameter of a 1-inch pipe. Select a solid round steel rod to fit the hole and cut 3 1/2-inches long. Cut a 24-inch length of 1-inch pipe to use as a handle. Weld handle, bar stock, and steel block together.

(2)  *Holding device.* Select a piece of steel 1/8 by 6 by 25 inches (fig. 6-3). Starting from the center (12 1/2 inch) form it into a 6-inch diameter circle. When the circle is completed bend the two ends approximately 3 inches out from the circle. Make up two pieces of steel each 3/8 by 3 by 4 1/2 inches and four pieces of steel each 3/8 by 1 1/2 by 3 5/8 inches. Along the four pieces of steel that have a length of 3 5/8 inches, taper the 1 1/2 inch surface to butt against the outside contour of the 6-inch circle. Weld one piece of steel 3/8 by 3 by 4 1/2 inches and two pieces of steel 3/8 by 1 1/2 by 3 5/8 inches to each end projecting from the circle. Drill four holes threaded 3/8-16NC in the four 3/8 by 1 1/2 by 3 5/8 inch steel pieces positioned to suit the vise. Install

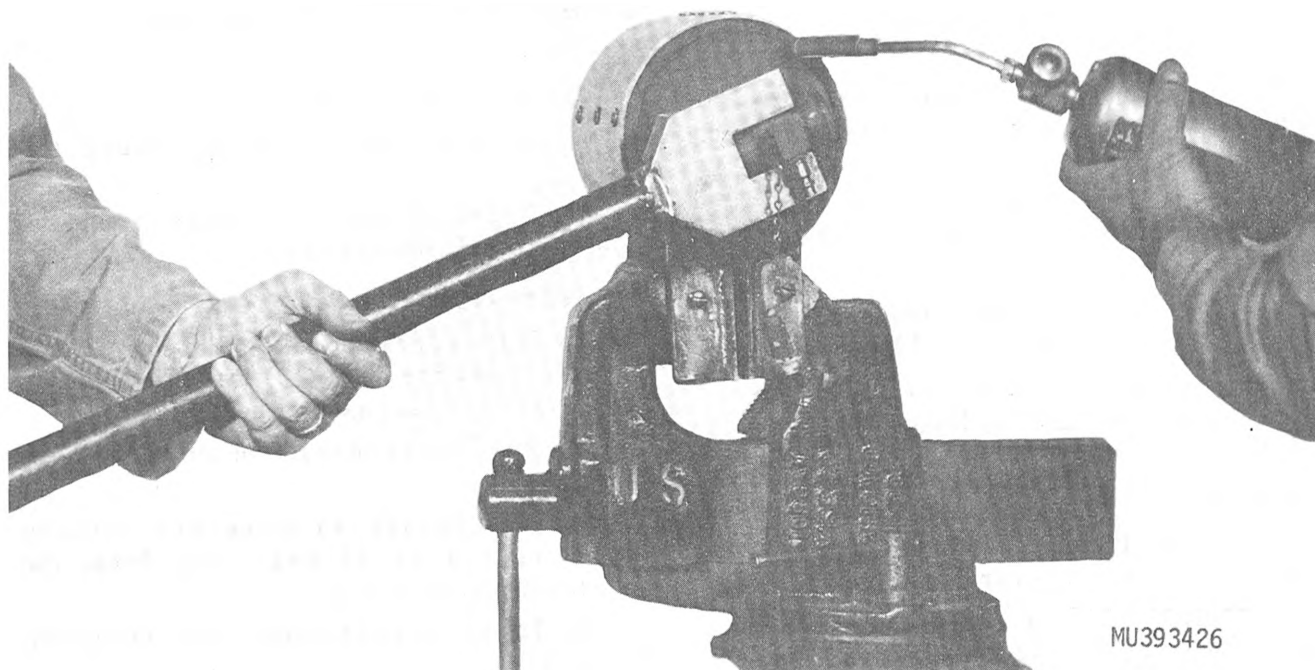

Figure 6-4. Pressure tank and pressure tank valve.

four screws. Drill 17 holes, which will be used for rivets, in the 1/8 by 6 by 25 inch piece of steel at locations similar to those shown in figure 6-3. Prepare a piece of leather 5/16 by 6 by 18 inches and rivet it in place inside the steel circle using approximately 17 countersunk rivets and washers as shown in figure 6-3. The holding device has a spread of about 3/4 inch when free and a spread of about 1/2 inch when compressed.

*c. Removal.*

(1) Perform the operations in paragraph 4-13a and b.

(2) Disconnect the coupling nut (13, fig. 5-6) from the pressure tank valve (18) and remove the valve shaft (7).

(3) Secure the pressure tank in the holding device (fig. 6-3). Place the parts in a vise shown in figure 6-4.

(4) Remove the plug assembly (17, fig. 5-6) and plug cap (14).

(5) Remove the check valve assembly (20) and the valve cap (21).

(6) With the wrench (fig. 6-4) remove the pressure tank valve from the pressure tank. The use of a propane torch or blow torch on the neck of the pressure tank will make it easier to remove the pressure tank valve.

*d. Assembly.*

**NOTE**

Use antisieze compound or tape on pipe threads before assembly.

(1) Screw the pressure tank valve into the opening of the pressure tank and tighten with the wrench (fig. 6-4).

(2) Screw a check valve assembly (20, fig. 5-6) to the side of the pressure tank valve (18) and tighten.

(3) Screw a plug assembly (17) to the bottom of the pressure tank valve (18) and tighten.

*e. Charging and Testing Pressure Tank.* Charge and test the pressure tank for leaks (TM 3-1040-221-12).

*f. Installation.*

(1) Connect the open end of the valve shaft (7, fig. 5-6) to the pressure tank valve (18).

(2) Connect the nut (13) that is on the valve shaft (7) to the pressure tank valve.

(3) Install the pressure tank to the fuel tanks (para 4-13c).

## 6-10. Pressure Regulator

General support maintenance personnel are authorized to replace the diaphragm, springs, strainer, valve adapters, and related hardware.

*a. Removal.*

(1) Remove the pressure tank and valve assembly (para 4-13a and b).

(2) To gain access to the pressure regulator, remove one cord attaching the carrier pack to the frame.

(3) Hold the pressure regulator and disconnect the diffusion tube nut.

(4) Remove the tube assembly (24, fig. 6-5) and adapter (17).

(5) Unscrew the safety valve and nipple (13) from the pressure regulator.

(6) Loosen the spring retaining plug (23) and remove it slowly to prevent the spring (21) from popping out of the cavity.

(7) Remove the preformed packing (22), spring (21), valve (20), strainer (19), valve seat assembly (18), gasket (16), and push rod (15).

(8) Remove eight screws (14). Slowly separate the pressure regulator body (12) from the dome (7) to prevent losing the compression spring (11).

(9) Remove the compression spring (11), diaphragm plate (10), and diaphragm (9) from the dome.

*b. Inspection and Cleaning.*

(1) Clean all parts with drycleaning solvent.

(2) Inspect all parts for damage, wear, deterioration, and serviceability.

*c. Assembly and Installation.*

(1) Press the center coil of the compression spring (11) into the plate (10). Install both parts into the cavity of the regulator body (12).

(2) Place the diaphragm on top of the plate (10).

(3) Aline the pin (8) in the dome (7) with the mating hole in the body (12). Press the dome to the regulator body.

(4) Install the eight screws (14) and tighten all screws.

(5) Position the push rod (15) in the body (12).

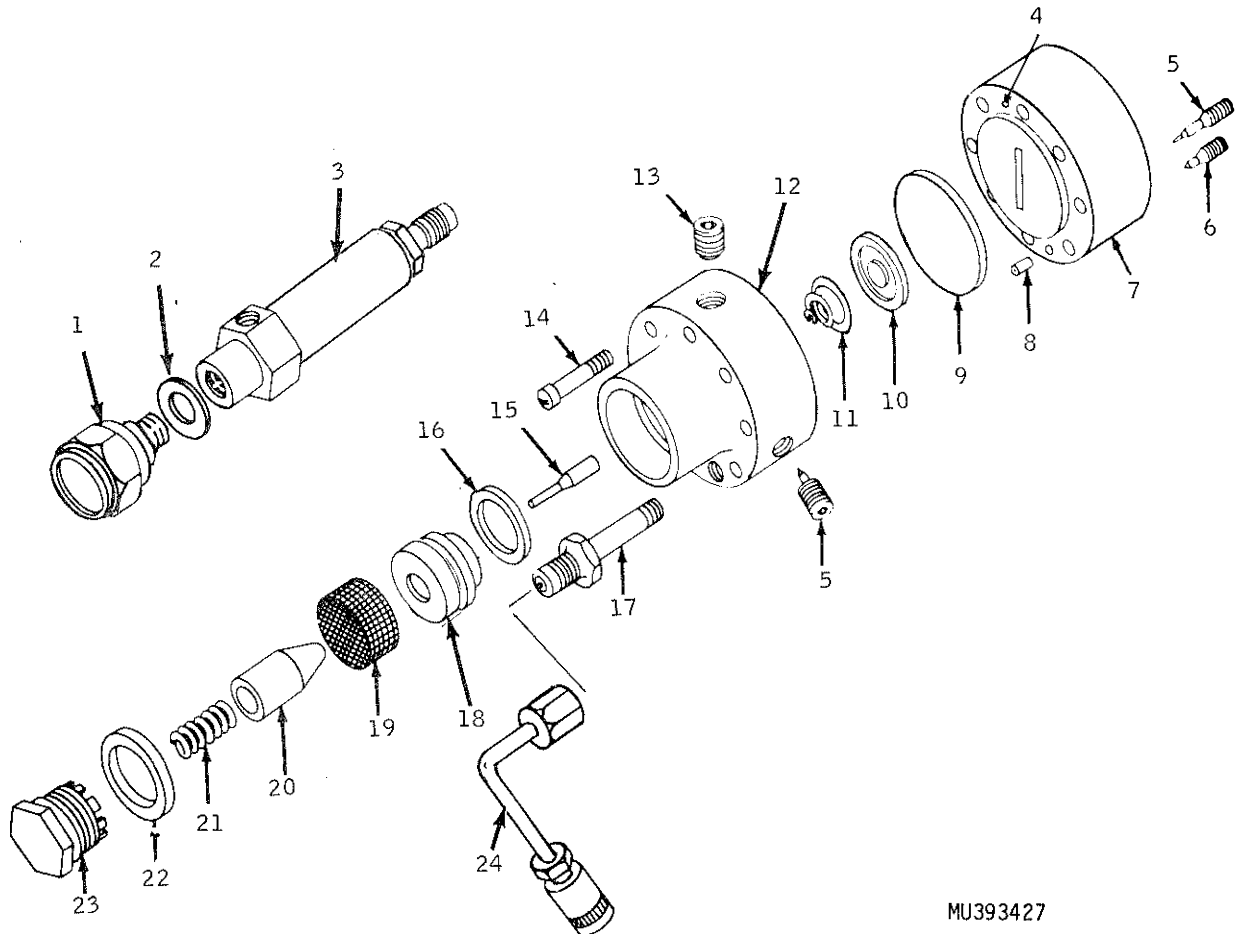

MU393427

- |                           |                                |                          |
|---------------------------|--------------------------------|--------------------------|
| 1 Safety head             | 9 Pressure regulator diaphragm | 17 Straight adapter      |
| 2 Gasket                  | 10 Diaphragm plate             | 18 Valve seat assembly   |
| 3 Safety valve            | 11 Compression spring          | 19 Strainer              |
| 4 Index pinhole           | 12 Pressure regulator body     | 20 Valve                 |
| 5 Needle valve No. 1      | 13 Pipe nipple                 | 21 Spring                |
| 6 Needle valve No. 2      | 14 Screw                       | 22 Packing               |
| 7 Pressure regulator dome | 15 Push rod                    | 23 Spring retaining plug |
| 8 Flange grommet          | 16 Valve seat gasket           | 24 Tube assembly         |

Figure 6-5. Pressure regulator, safety valve, and safety head, exploded view.

(6) Install the gasket (16), valve seat assembly (18), and strainer (19).

(7) Install the valve (20) so that the depression in the valve is seated over the end of the push rod (15).

(8) Install the spring (21).

(9) Slide the preformed packing over the threaded portion of the plug (23). Screw the plug (23) into the body (12).

(10) Apply antiseize compound or tape to the threads on the nipple (13).

(11) Screw the nipple (13) into the regulator body (12).

(12) Screw the side of the safety valve (3) to the nipple (13).

(13) Tighten the pressure regulator to the safety valve by hand until it is tight and in line with one another as shown in figure 4-2.

(14) Install adapter (17, fig. 6-5) and tighten.

(15) Install gasket (2) on the safety valve (3).

(16) Install safety head (1).

(17) Install pressure regulator assembly with the diffusion tube nut.

(18) Loosely connect the tube assembly (24) to inlet adapter (17).

(19) Locate the quick-disconnect coupling half so that it is an equal distance between the fuel tanks. Tighten the tube nut to adapter (17).

(20) Connect carrier pack to frame with cord.

(21) Install pressure tank and valve assembly (para 4-13c).

## CHAPTER 7

### SHIPMENT, ADMINISTRATIVE STORAGE, AND DESTRUCTION TO PREVENT ENEMY USE

---

#### Section I. SHIPMENT AND ADMINISTRATIVE STORAGE

##### 7-1. Shipment

The flamethrower is shipped in its wood packing chest. Prepare the flamethrower for shipment as follows:

*a.* See that the after-operation services have been performed (para 4-17).

*b.* Seal all openings with masking tape and repack flamethrower.

##### 7-2. Administrative Storage

Store the flamethrower in the packing chest. Refer to TM 740-90-1 for administrative storage instructions on this equipment.

#### Section II. DESTRUCTION TO PREVENT ENEMY USE

##### 7-3. General

When capture by or abandonment of the flamethrower to an enemy is imminent, the responsible unit commander must make the decision either to destroy the flamethrower or to render it inoperative. Based on this decision, orders are issued which cover the desired extent of demolition. Whatever method of demolition is employed, it is essential to destroy the same vital parts of all units and all corresponding repair parts.

##### 7-4. Gun

Demolish gun, valves, and tubes with a sledgehammer, ax, or other means.

##### 7-5. Air Pressure Tank and Fuel Tanks

Fire small arms bullets through the fuel tanks, pressure tank, and pressure regulator. If necessary to fire pointblank into the pressure tank, first open the high-pressure valve to release any air pressure to eliminate any danger of explosion.

##### 7-6. Hose Assembly

Destroy the hose by cutting it with an ax or by smashing fittings with a heavy implement.

##### 7-7. Ignition Cylinders

Destroy ignition cylinders by burning them. Personnel should stay several yards away from the fire, because the ignition cylinders ignite with a slight detonation.

**APPENDIX A****REFERENCES**

---

FM 20-33	Combat Flame Operations
TM 3-366	Flame Fuels
TM 3-1040-221-12	Operator's and Organizational Maintenance Manual, Service Kit, Portable Flamethrower-Riot Control Agent Dispenser, M27
TM 3-1040-251-15	Operator's, Organizational, Direct Support, General Support, and Depot Maintenance Manual, Test Set, Flamethrower-Riot Control Agent Dispenser, Hydrostatic-and-Volumetric, 6,000 PSI, M5
TM 38-750	The Army Maintenance Management System (TAMMS)
TM 9-213	Painting Instructions for Field Use
TM 740-90-1	Administrative Storage of Equipment
SB 700-50	Expendable Items: (Except: Medical, Class V, Repair Parts and Heralsic Items).

## APPENDIX B

### BASIC ISSUE ITEMS LIST AND ITEMS TROOP INSTALLED OR AUTHORIZED LIST AND ORGANIZATIONAL, DIRECT SUPPORT, AND GENERAL SUPPORT MAINTENANCE REPAIR PARTS AND SPECIAL TOOLS LIST (INCLUDING DEPOT MAINTENANCE REPAIR PARTS AND SPECIAL TOOLS

---

#### Section I. INTRODUCTION

##### B-1. Scope

This appendix lists basic issue items, items troop installed or authorized and repair parts required for the performance of organizational, direct support, general support, and depot maintenance of the M2A1-7 portable flamethrower.

##### B-2. General

This Basic Issue Items, Items Troop Installed or Authorized, Repair Parts, and Special Tools List is divided into the following sections:

*a. Basic Issue Items List—Section II.* Not applicable.

*b. Items Troop Installed or Authorized List—Section II.* Not applicable.

*c. Repair Parts List—Section IV.* A list of repair parts authorized at the organizational level for the performance of maintenance. The list also includes parts which must be removed for replacement of the authorized parts. Parts lists are composed of functional groups in ascending numerical sequence, with the parts in each group listed in figure and item number sequence.

*d. Special Tools List—Section V.* Not applicable.

*e. Repair Parts List—Section VI.* A list of repair parts authorized at the direct support, general support, and depot levels for the performance of maintenance. The list also includes parts which must be removed for the replacement of the authorized parts. Parts lists are composed of functional groups in ascending numerical se-

quence, with parts in each group listed in figure and item number sequence.

*f. Special Tools List—Section VII.* Not applicable.

*g. Federal Stock Number and Reference Number Index—Section VIII.* A list, in ascending numerical sequence, of all Federal stock numbers appearing in the listing, followed by a list, in alphameric sequence, of all reference numbers appearing in the listings. Federal stock numbers and reference numbers are cross-referenced to each illustration figure and item number appearance.

##### B-3. Explanation of Columns

The following provides an explanation of columns found in the tabular listing.

*a. Source, Maintenance, Recoverability Codes (SMR).*

(1) *Source code.* Source codes are assigned to support items to indicate the manner of acquiring support items for maintenance, repair, or overhaul of end items. Source codes are entered in the first and second positions of the Uniform SMR Code Format as follows:

Code	Definition
PA	Item procured and stocked for anticipated or known usage.
PB	Item procured and stocked for insurance purpose because essentiality dictates that a minimum quantity be available in the supply systems.
PC	Item procured and stocked and which otherwise would be coded PA except that it is deteriorative in nature.

<i>Code</i>	<i>Definition</i>
PD	Support item, excluding support equipment, procured for initial issue or outfitting and stocked only for subsequent or additional initial issues or outfittings. Not subject to automatic replenishment.
PE	Support equipment procured and stocked for initial issue or outfitting to specified maintenance repair activities.
PF	Support equipment which will not be stocked but which will be centrally procured on demand.
PG	Item procured and stocked to provide for sustained support for the life of the equipment. It is applied to an item peculiar to the equipment which because of probable discontinuance or shutdown of production facilities would provide uneconomical to reproduce at a later time.
KD	An item of depot overhaul/repair kit and not purchased separately. Depot kit defined as a kit that provides items required at the time of overhaul or repair.
KF	An item of a maintenance kit and not purchased separately. Maintenance kit defined as a kit that provides an item that can be replaced at organizational or intermediate levels of maintenance.
KB	Item included in both a depot overhaul/repair kit and a maintenance kit.
MO	Item to be manufactured or fabricated at organizational level.
MF	Item to be manufactured or fabricated at the direct support maintenance level
MH	Item to be manufactured or fabricated at the general support maintenance level.
MD	Item to be manufactured or fabricated at the depot maintenance level.
AO	Item to be assembled at organization level.
AF	Item to be assembled at direct support maintenance level.
AH	Item to be assembled at general support maintenance level.
AD	Item to be assembled at depot maintenance level.

<i>Code</i>	<i>Definition</i>
XA	Item is not procured or stocked because the requirements for the item will result in the replacement of the next higher assembly.
XB	Item is not procured or stocked. If not available through salvage, requisition.

**NOTE**

Cannibalization or salvage may be used as a source of supply for any items source coded above except those coded XA and aircraft support items as restricted by AR 700-42.

(2) *Maintenance code.* Maintenance codes are assigned to indicate the levels of maintenance authorized to USE and REPAIR support items. The maintenance codes are entered in the third and fourth positions of the Uniform SMR Code Format as follows:

**USE (THIRD POSITION):** The maintenance code entered in the third position indicates the lowest maintenance level authorized to remove, replace, and use the support item. The maintenance code entered in the third position will indicate one of the following levels of maintenance:

<i>Code</i>	<i>Application/Explanation</i>
C	Crew or operator maintenance performed within organizational maintenance.
O	Support item is removed, replaced, used at the organizational level.
F	Support item is removed, replaced, used at the direct support level.
H	Support item is removed, replaced, used at the general support level.
D	Support items that are removed, replaced, used at Depot, Mobil Depot, Specialized Repair Activity only.

**REPAIR (FOURTH POSITION):** The maintenance code entered in fourth position indicates whether the item is to be repaired and identifies the lowest maintenance level with the capability to perform complete repair (i.e., all authorized maintenance functions). This position contains one of the following maintenance codes:

<i>Code</i>	<i>Application/Explanation</i>
O	The lowest maintenance level capable of complete repair of the support item is the organizational level.

<i>Code</i>	<i>Application/Explanation</i>
F	The lowest maintenance level capable of complete repair of the support item is the direct support level.
H	The lowest maintenance level capable of complete repair of the support item is the general support level.
D	The lowest maintenance level capable of complete repair of the support item is the depot level.
L	Repair restricted to designated Specialized Repair Activity.
Z	Non-repairable. No repair is authorized.
B	No repair is authorized. The item may be reconditioned by adjusting, lubricating, etc., at the user level. No parts or special tools are procured for the maintenance of this item.

(3) *Recoverability code.* Recoverability codes are assigned to support items to indicate the disposition action on unserviceable items. The recoverability code is entered in the fifth position of the Uniform SMR Code Format as follows:

<i>Recoverability Codes</i>	<i>Definition</i>
Z	Non-repairable. When unserviceable, condemn, and dispose at the level indicated in position 3.
O	Repairable item. When uneconomically repairable, condemn and dispose at organizational level.
F	Repairable item. When uneconomically repairable, condemn and dispose at the direct support level.
H	Repairable item. When uneconomically repairable, condemn and dispose at the general support level.
D	Repairable item. When beyond lower level repair capability, return to depot. Condemnation and disposal not authorized below depot level.
L	Repairable item. Repair, condemnation and disposal not authorized below Depot/Specialized Repair Activity level.
A	Item requires special handling or condemnation procedures because of specific reasons (i.e., precious metal content, high dollar value, critical material or hazardous material). Refer to appropriate manuals/directives for specific instructions.

*b. Federal Stock Number.* Indicates the Federal stock number assigned to the item and will be used for requisitioning purposes.

*c. Description.* Indicates the Federal item name and a minimum description required to identify the item. The last line indicates the reference number followed by the applicable Federal Supply Code for Manufacturer (FSCM) in parentheses. The FSCM is used as an element in item identification to designate manufacturer or distributor or Government agency, etc., and is identified in SB 708-4.

*d. Unit of Measure (U/M).* Indicates the standard or basic quantity by which the listed item is used in performing the actual maintenance function. This measure is expressed by a two-character alphabetical abbreviation, e.g., ea, in., pr., etc., and is the basis used to indicate quantities and allowances in subsequent columns. When the unit of measure differs from the unit of issue, the lowest unit of issue that will satisfy the required units of measure will be requisitioned.

*e. Quantity Incorporated in Unit.* Indicates the quantity of the item used in the breakout shown on the illustration figure, which is prepared for a functional group, subfunctional group, or an assembly. A "V" appearing in this column in lieu of a quantity indicates that no specific quantity is applicable, e.g., shims, spacers, etc.

*f. 15-Day Organizational Maintenance Allowances.*

(1) Repair parts source coded PA, PB, PC, PD, PE, PF, and/or PG are authorized for use at the organizational level, and will be requisitioned on an "as required" basis until stockage is based on demand in accordance with AR 710-2.

(2) Major Army commanders are authorized to approve reductions in the range of support items authorized for use in units within their commands. Recommendations for increases, in range of items authorized for use, should be forwarded to the Commander, Edgewood Arsenal, Attn: SMUEA-DE-ETL, Aberdeen Proving Ground, MD 21010, for action on such recommendations. Changes approved will be reflected in a revision to the manual.

*g. 30-Day DS/GS Maintenance Allowances.*

(1) Repair parts source coded PA, PB, PC, PD, PE, PF, and/or PG authorized for use at the direct support (DS) and/or general support

(GS) levels will be requisitioned on an "as required" basis.

(2) The repair parts authorized at the DS/GS levels are for the maintenance mission at these levels.

(3) Requirements for repair parts stockage and for distribution to supported units will be based on demand and determined in accordance with AR 710-2.

*h. 1-Year Allowances Per 100 Equipments/Contingency Planning Purposes.* Total quantities of repair parts required for distribution and contingency planning purposes will be based on demand data.

*i. Depot Maintenance Allowance Per 100 Equipments.* Repair parts authorized for use at the depot level will be requisitioned on an "as required" basis.

*j. Illustration.* This column is divided as follows:

(1) *Figure number.* Indicates the figure number of the illustration on which the item is shown.

(2) *Item number.* Indicates the callout number used to reference the item on the illustration.

**B-4. Special Information**

*a.* Detailed assembly instructions for items source coded "A" are found in this manual. Assembly components are listed immediately following the item to be assembled.

*b.* Repair parts kits are listed in Repair Kit Group in ascending Federal stock number sequence. The Federal Stock Number and Reference Number Index will reference the word KIT in the figure number column

*c.* Action change codes indicated in the left-hand margin of the listing page denote the following:

- N—indicates an added item.
- C—indicates a change in data.
- R—indicates a change in FSN only.

**B-5. How to Locate Repair Parts**

*a.* When Federal stock number or reference number is unknown:

(1) *First.* Using the Table of Contents, determine the functional group within which the repair part belongs, i.e., gun, hose, tank. This is necessary since illustrations are prepared for functional groups and listings are divided into the same groups.

(2) *Second.* Find the illustration covering the group to which the repair part belongs.

(3) *Third.* Identify the repair part on the illustration and note the illustration figure and item number of the repair part.

(4) *Fourth.* Using the Repair Parts Listing, find the functional group to which the repair part belongs and locate the illustration figure and item number noted on the illustration.

*b.* When Federal stock number or reference number is known:

(1) *First.* Using the Index of Federal Stock Numbers and Reference Numbers, find the pertinent Federal stock number or reference number. This index is in ascending FSN sequence followed by a list of reference numbers in ascending alphameric sequence, cross-referenced to the illustration figure number and item number.

(2) *Second.* Using the Repair Parts Listing, find the functional group of the repair part and the illustration figure number and item number referenced in the Index of Federal Stock Numbers and Reference Numbers.

**B-6. Abbreviations**

<i>Abbreviations</i>	<i>Explanation</i>
NPT .....	National Pipe Thread
unc .....	Unified course thread

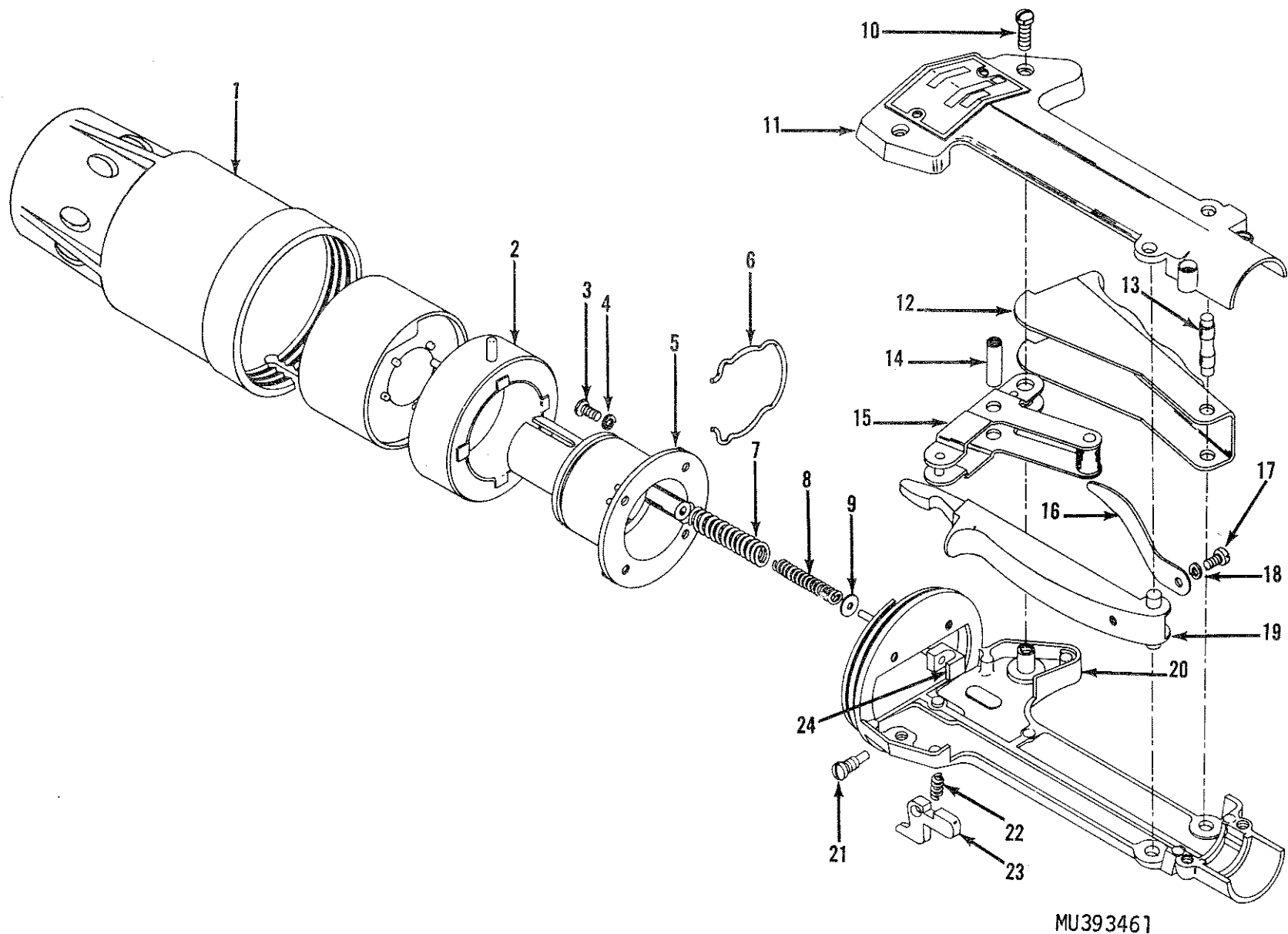
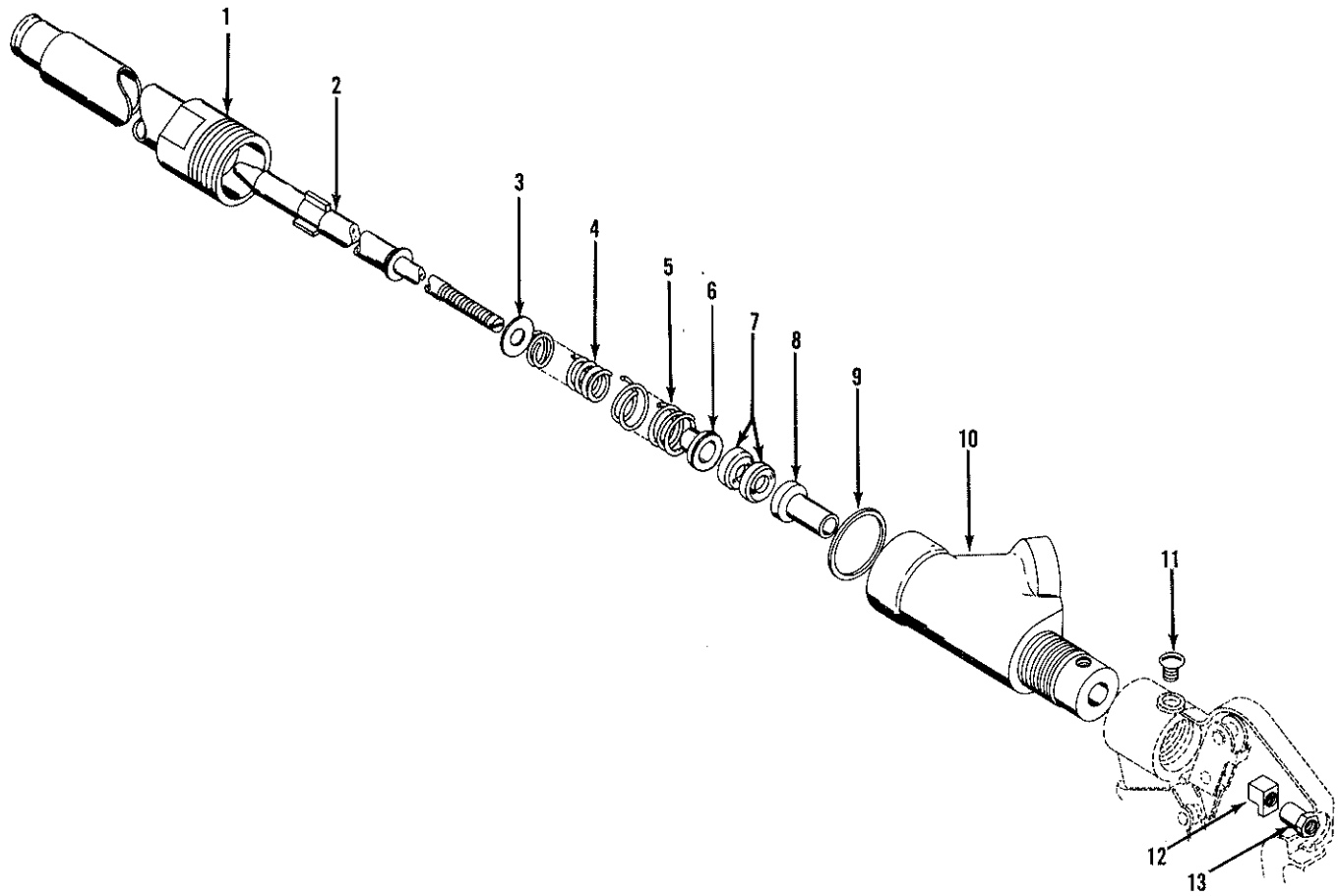
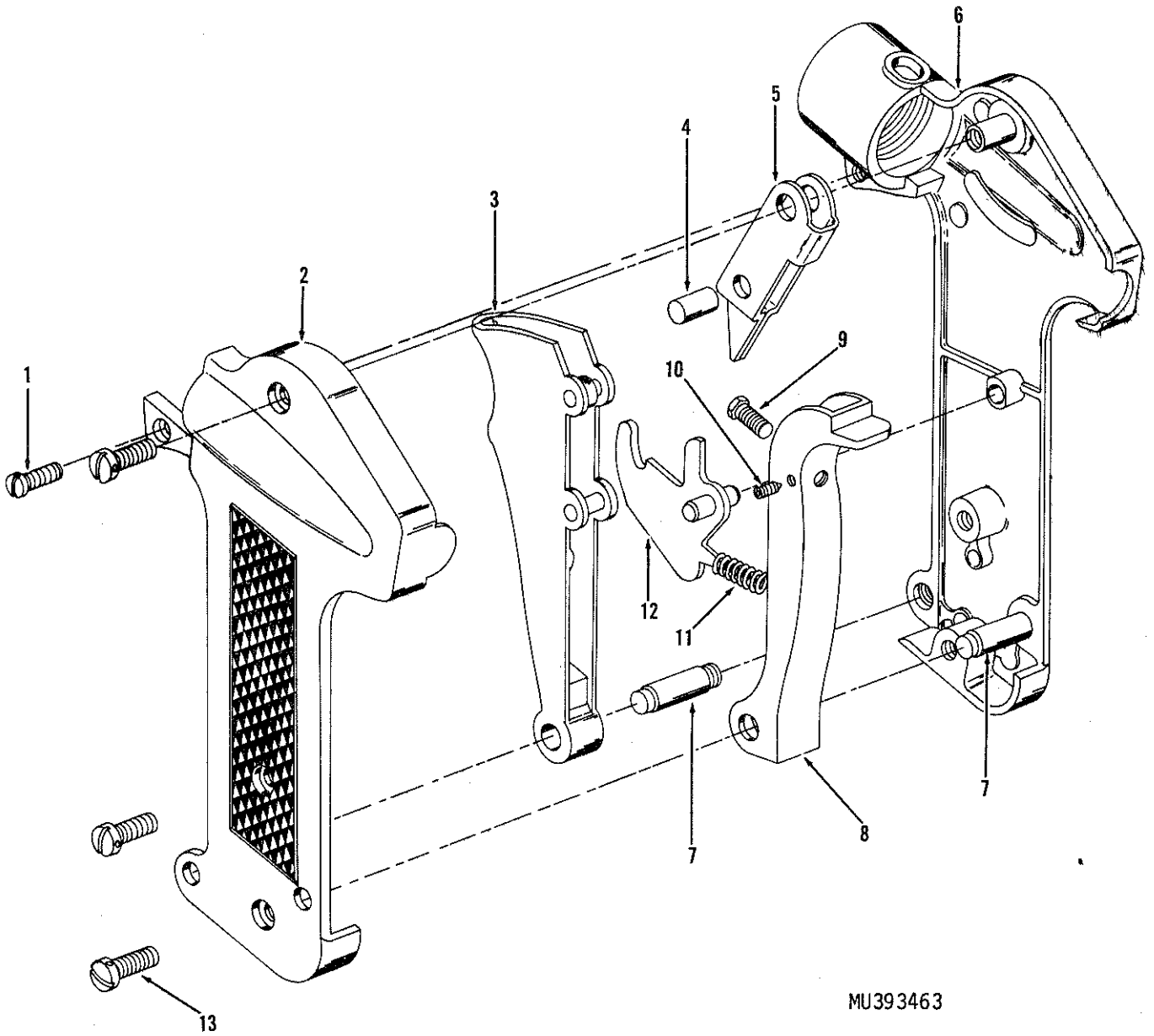

Figure B-1. Gun group, ignition head and grip section.



MU393462

Figure B-2. Gun group, valve section.



MU393463

Figure B-3. Gun group, valve section, valve grip parts.

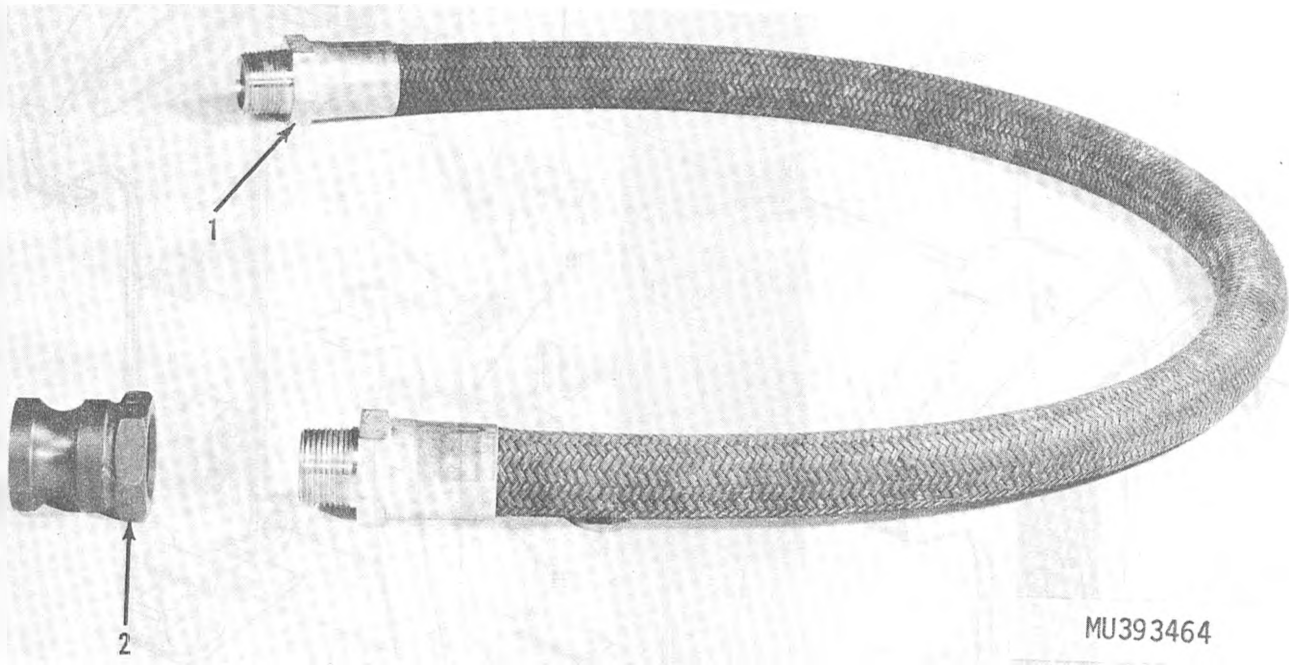

*Figure B-4. Hose group.*

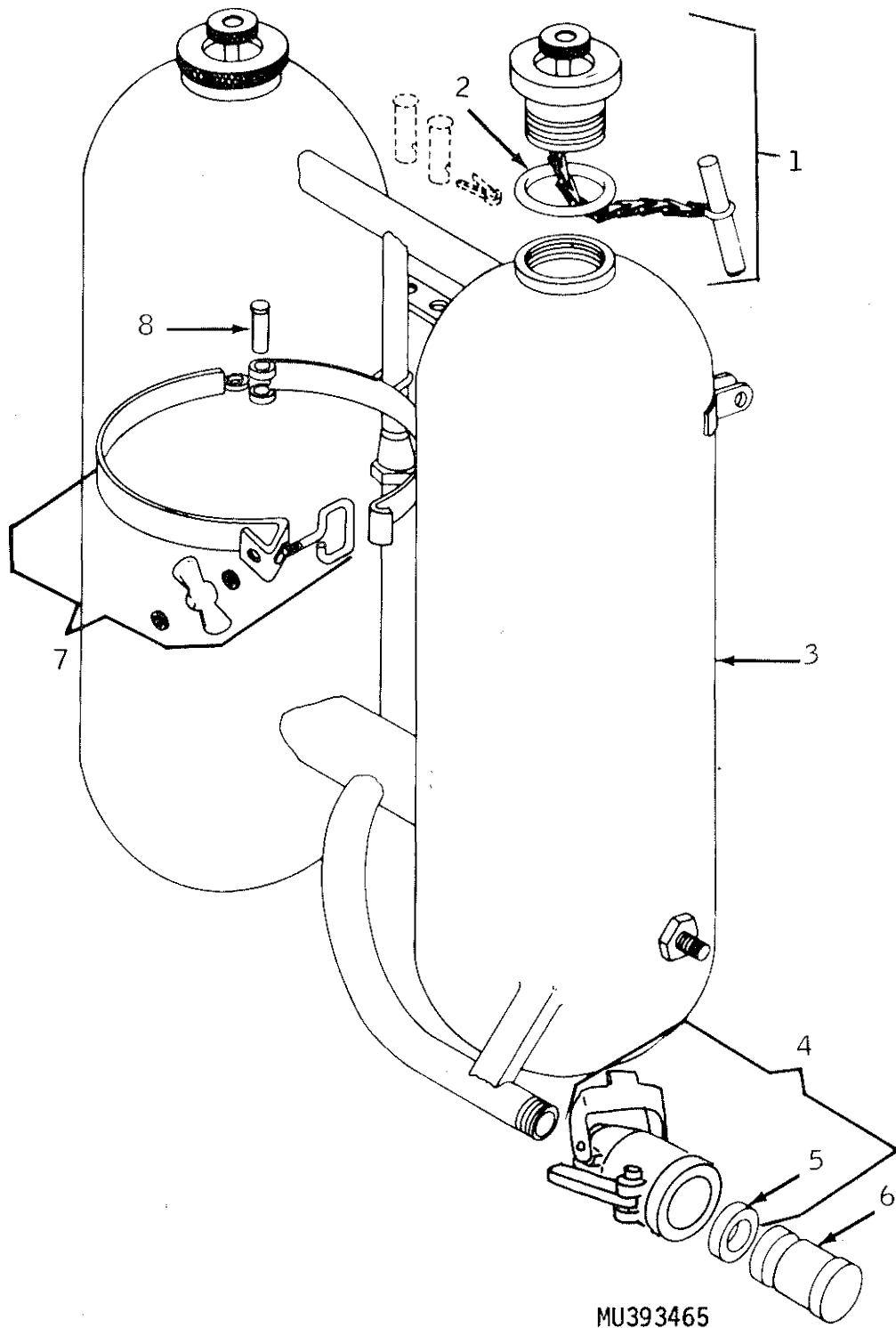
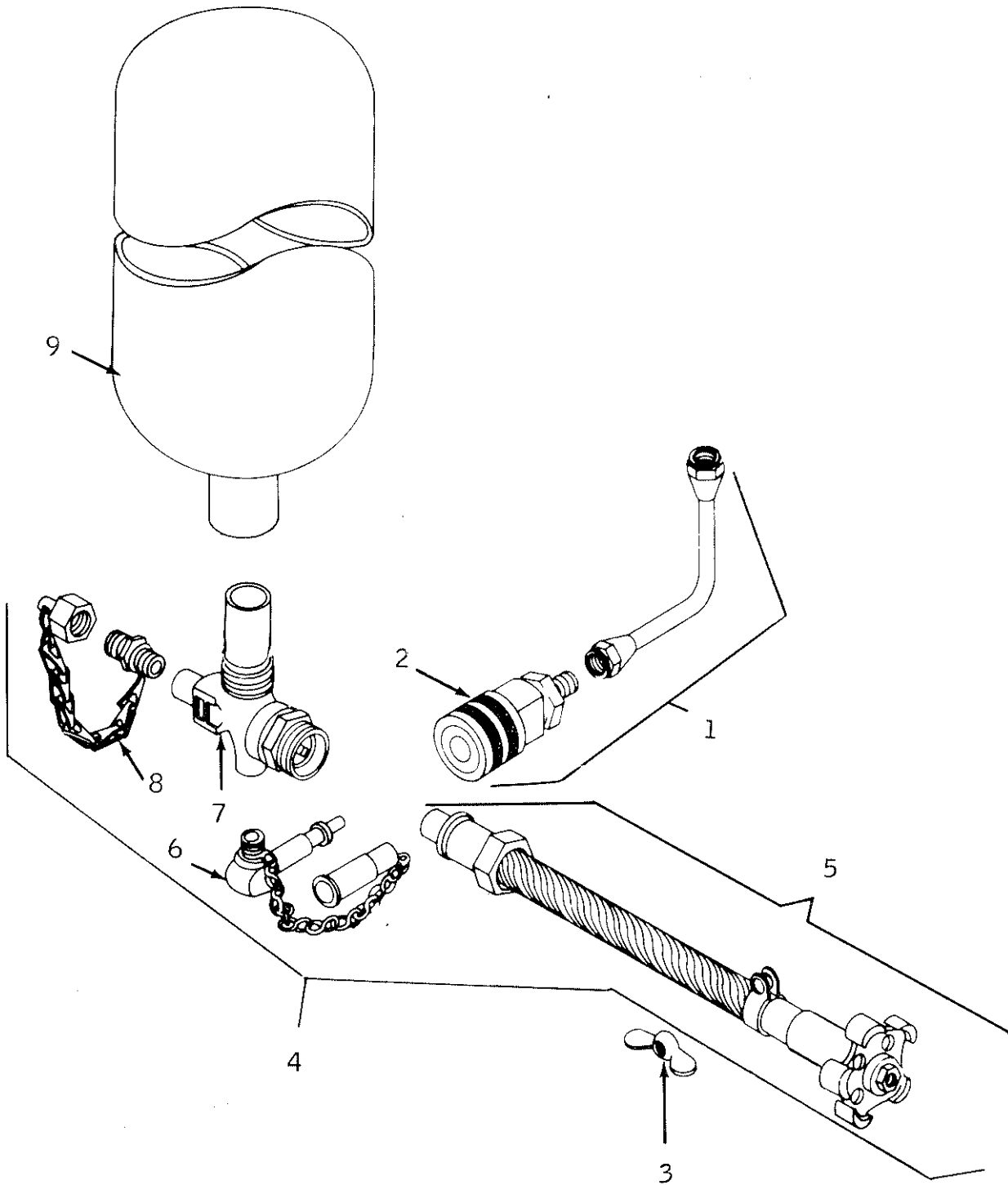
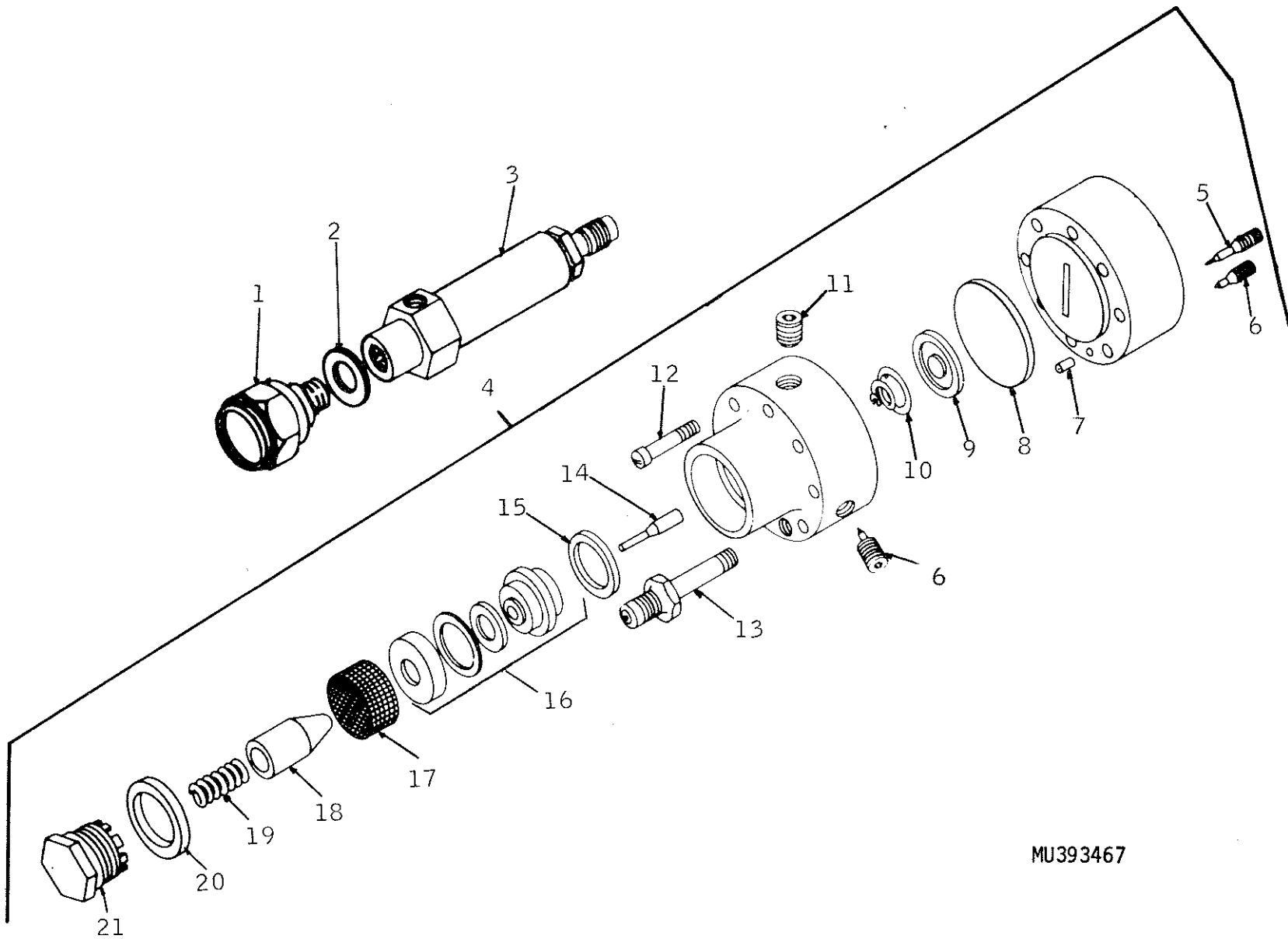

Figure B-5. Tank group, fuel section.



MU393466

Figure B-6. Tank group, pressure section.



MU393467

Figure B-7. Tank group, pressure section regulator and safety valve.

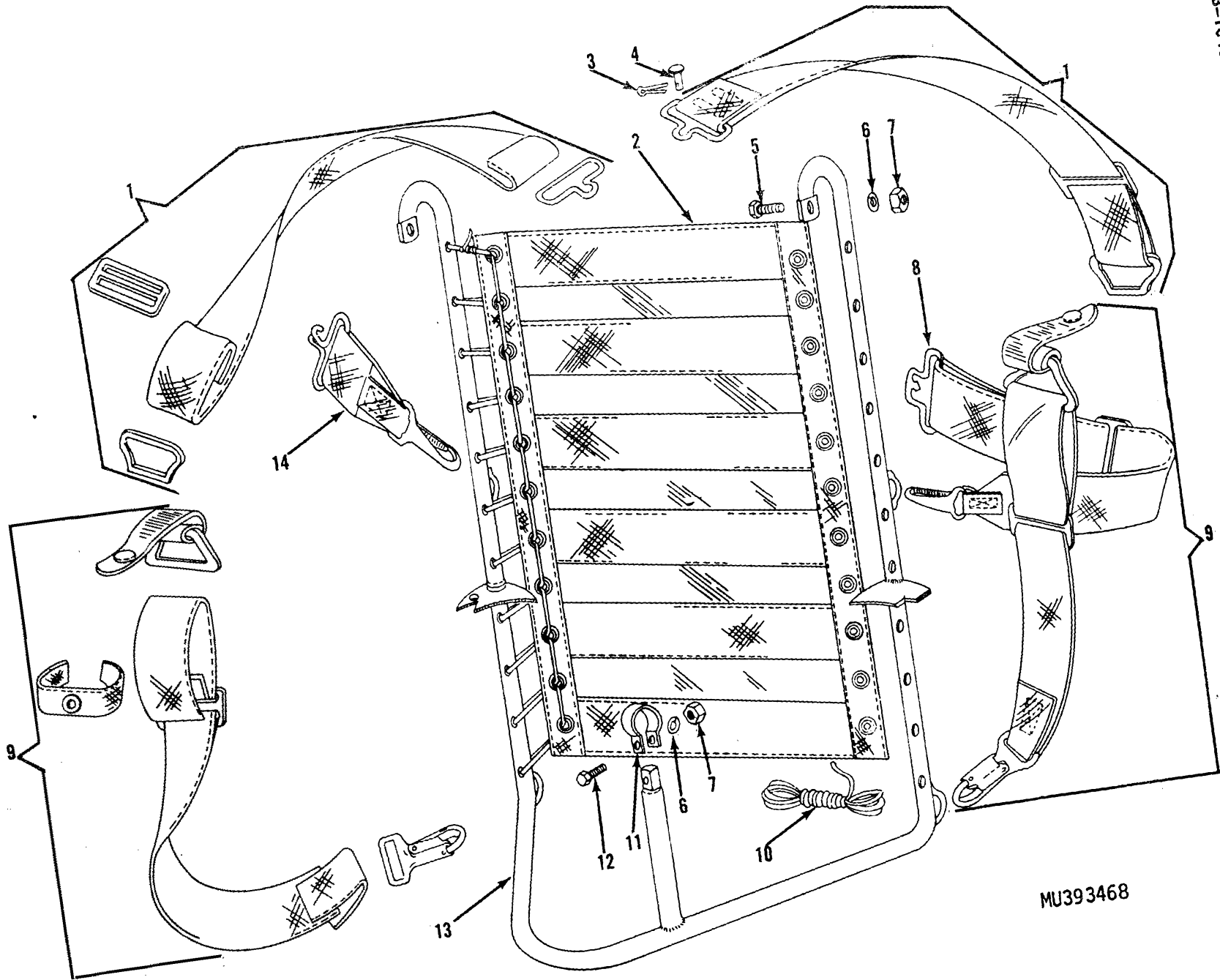

MU393468

Figure B-8. Tank group, carrier section.

TM 3-1040-204-14

Section IV. REPAIR PARTS LIST

(1) SMR CODE	(2) FEDERAL STOCK NUMBER	(3) DESCRIPTION  Reference Number & Mfr. Code	(4) UNIT OF MEAS.	(5) QTY INC IN UNIT	(6) 15-DAY ORGANIZATIONAL MAINTENANCE ALW.				(7) ILLUSTRATION	
					(a) 1-5	(b) 6-20	(c) 21-50	(d) 51-100	(a) FIGURE NO.	(b) ITEM NO.
		GROUP 100 - GUN GROUP IGNITION SECTION IGNITION GRIP PARTS								
C	PB OZ Z 1040-347-2429	SHIELD NOZZLE  C81-1-4921 (81361)	ea	1					B-1	1
		GROUP 300 - TANK GROUP								
C	PB OH Z 1040-784-9218	PLUG ASSEMBLY, FILLING  D81-1-4883 (81361)	ea	2					B-5	1
C	PA OZ Z 5330-265-1092	PACKING, PREFORMED,  synthetic rubber, cross-sectional dim. 0.143 in. max, cross-sectional H, 1.302 in. max center hole dia  MS29513-219 (96906)	ea	2					B-5	2
C	PB OZ Z 5330-202-4249	GASKET, SYNTHETIC RUBBER  1-1/16 in. dia of aperture, 1-9/16 in. od, 7/32 in. thk  A81-1-4573 (81361)	ea	1					B-5	5

B-5

TM 3-1040-204-14  
Section IV. REPAIR PARTS LIST - Continued

B-5

	(1) SMR CODE	(2) FEDERAL STOCK NUMBER	(3) DESCRIPTION  Reference Number & Mfr. Code	(4) UNIT OF MEAS	(5) QTY INC IN UNIT	(6) 15-DAY ORGANIZATIONAL MAINTENANCE ALLOW				(7) ILLUSTRATION	
						(a) 1-5	(b) 6-20	(c) 21-50	(d) 51-100	(a) FIGURE NO.	(b) ITEM NO.
C	PB OZ Z	4730-160-8062	PLUG, QUICK DISCONNECT B81-1-514 (81361)	ea	1					B-5	6
C	PB OZ Z	5310-209-2652	NUT, PLAIN, WING 1/4-20UNC-2B A81-1-877 (81361)	ea	1					B-6	3
C	PB OH H	1040-293-5891	TANK AND VALVE PRESSURE B81-1-879 (81361) CARRIER SECTION	ea	1					B-6	4
C	PA OZ Z	1040-205-0358	STRAP ASSEMBLY, UPPER B81-1-520 (81361)	ea	2					B-8	1
C	PA OZ Z	1040-696-1374	PACK, CARRIER C81-1-873 (81361)	ea	1					B-8	2
C	PA OZ Z	1040-205-0360	STRAP ASSEMBLY B81-1-519 (81361)	ea	1					B-8	8
C	PA OZ Z	1040-205-0361	STRAP ASSEMBLY, LOWER B81-1-520 (81361)	ea	2					B-8	9

TM 3-1040-204-14

Section IV. REPAIR PARTS LIST - Continued

(1) SMR CODE	(2) FEDERAL STOCK NUMBER	(3) DESCRIPTION  Reference Number & Mfr. Code	(4) UNIT OF MEAS	(5) QTY INC IN UNIT	(6) 15-DAY ORGANIZATIONAL MAINTENANCE ALLOWANCE				(7) ILLUSTRATION	
					(a) 1-5	(b) 6-20	(c) 21-50	(d) 51-180	(a) FIGURE NO.	(b) ITEM NO.
C	PB OZ Z 4020-993-5383	CORD, NYLON,  9 carriers per braid, 1 yarn per carrier, single yarn, olive drab, 1/8 in. nom dia, 400 lb breaking strength MIL-C-43307 (81349)	ft	12					B-8	10
C	PA OZ Z 1040-205-0359	STRAP ASSEMBLY, SHORT  B81-1-519 (81361)	ea	1					B-8	14

## Section VI. REPAIR PARTS LIST

(1) SMR CODE	(2) FEDERAL STOCK NUMBER	(3) DESCRIPTION  Reference Number & Mfr. Code Usability Code	(4) UNIT OF MEAS	(5) QTY INC IN UNIT	(6) 30-DAY DS MAINT ALLOWANCE			(7) 30-DAY GS MAINT ALLOWANCE			(8) 1-YR ALW PER 100 EQUIP CNTGCY	(9) DEFOT MAINT ALW PER 100 EQUIP	(10) ILLUSTRATION	
					(a)	(b)	(c)	(a)	(b)	(c)			(a)	(b)
					1-20	21-50	51-100	1-20	21-50	51-100			FIGURE NO.	ITEM NO.
C	PB FH H 1040-347-2411	GUN, PORTABLE, FLAMETHROWER, M7 D81-1-4920 (81361)  GROUP 100 - GUN GROUP  IGNITION SECTION  IGNITION GRIP PARTS	ea	1									B-1, B-2, B-3	
C	PB OZ Z 1040-347-2429	SHIELD, NOZZLE C81-1-4921 (81361)	ea	1									B-1 1	
C	PB FZ Z 1040-160-8082	CASE, SPRING ASSEMBLY B81-1-444 (81361)	ea	1									B-1 2	
C	PA FZ Z 5305-984-6189	SCREW, MACHINE, stl, pltd, pan hd, cross recess drive, No. 8-32, 0.250 in. lg MS35206-241 (96906)	ea	4									B-1 3	
C	PA FZ Z 5310-045-3299	WASHER, LOCK, stl, pltd, No. 8 nom screw size MS35338-42 (96906)	ea	4									B-1 4	

TM 3-1040-204-14

Section VI. REPAIR PARTS LIST - Continued

(1) SMR CODE	(2) FEDERAL STOCK NUMBER	(3) DESCRIPTION  Reference Number & Mfr. Code	(4) UNIT OF MEAS	(5) QTY INC IN UNIT	(6) 30-DAY DS MAINT ALLOWANCE			(7) 30-DAY GS MAINT ALLOWANCE			(8) 1-YR ALW PER 100 EQUIP CNTGCT	(9) DEPOT MAINT ALW PER 100 EQUIP	(10) ILLUSTRATION	
					(a) 1-20	(b) 21-50	(c) 51-100	(a) 1-20	(b) 21-50	(c) 51-100			(a) FIGURE NO.	(b) ITEM NO.
C	PB FZ Z 1040-347-2427	BODY, IGNITION HEAD D81-1-4922 (81361)	ea	1									B-1 5	
C	PB FZ Z 5340-160-8078	RING, SNAP A81-1-460 (81361)	ea	1									B-1 6	
C	PA FZ Z 1040-347-2408	SPRING, HELICAL COMPRESSION C81-1-4944 (81361)	ea	1									B-1 7	
C	PA FZ Z 5360-347-2409	SPRING, HELICAL COMPRESSION C81-1-4943 (81361)	ea	1									B-1 8	
C	PA FZ Z 5310-596-0134	WASHER, FLAT rd, brass, 0.130 id, 0.359 od, 0.025 in. thk A81-1-4984 (81361)	ea	1									B-1 9	
C	PA FZ Z 5305-614-0245	SCREW, MACHINE stl, pltd, fillister hd, No. 10-24, 5/8 in. lg MS35265-64 (96906)	ea	4									B-1 10	

TM 3-1040-204-14  
Section VI. REPAIR PARTS LIST - Continued

(1) SMR CODE	(2) FEDERAL STOCK NUMBER	(3) DESCRIPTION  Reference Number & Mfr. Code	(4) UNIT OF MEAS	(5) QTY INC IN UNIT	(6) 30-DAY DS MAINT ALLOWANCE			(7) 30-DAY GS MAINT ALLOWANCE			(8) 1-YR ALW PER 100 EQUIP CNTGCV	(9) DEPOT MAINT ALW PER 100 EQUIP	(10) ILLUSTRATION	
					(a)	(b)	(c)	(a)	(b)	(c)			(a)	(b)
					1-20	21-50	51-100	1-20	21-50	51-100			FIGURE NO.	ITEM NO.
C	PA FZ Z 1040-347-2432	COVER, IGNITION GRIP D81-1-4924 (81361)	ea	1									B-1	11
C	PA FZ Z 1040-739-2105	LEVER ASSEMBLY, IGNITION C81-1-4931 (81361)	ea	1									B-1	12
C	PA FZ Z 5315-292-9734	PIN, SHOULDER, HEADLESS A81-1-4932 (81361)	ea	1									B-1	13
C	PA FZ Z 5315-292-9742	PIN, STRAIGHT, HEADLESS A81-1-4939 (81361)	ea	1									B-1	14
C	PA FZ Z 1040-739-2104	LINK, IGNITION B81-1-4938 (81361)	ea	1									B-1	15
C	PA FZ Z 1040-739-2107	SPRING, IGNITION SAFETY LEVER B81-1-4927 (81361)	ea	1									B-1	16
C	PA FZ Z 5305-984-6189	SCREW, MACHINE stl, pltd, pan hd, cross drive, No. 8-32, 0.250 in. lg MS35206-241 (96906)	ea	1									B-1	17

TM 3-1040-204-14  
Section VI. REPAIR PARTS LIST - Continued

(1) SMR CODE	(2) FEDERAL STOCK NUMBER	(3) DESCRIPTION  Reference Number & Mfr. Code	(4) UNIT OF MEAS	(5) QTY INC IN UNIT	(6) 30-DAY DS MAINT ALLOWANCE			(7) 30-DAY GS MAINT ALLOWANCE			(8) 1-YR ALW PER 100 EQUIP CNTGCT	(9) DEPOT MAINT ALW PER 100 EQUIP	(10) ILLUSTRATION	
					(a) 1-20	(b) 21-50	(c) 51-100	(a) 1-25	(b) 21-50	(c) 51-100			(a) FIGURE NO.	(b) ITEM NO.
C	PA FZ Z 5310-045-3299	WASHER, LOCK  stl, pltd, No. 8 screw size  MS35338-42 (96906)	ea	1									B-1	18
C	PA FZ Z 1040-347-2421	LEVER ASSEMBLY, IGNITION SAFETY  B81-1-4928 (81361)	ea	1									B-1	19
C	PA FZ Z 1040-347-2431	GRIP ASSEMBLY, IGNITION  C81-1-6201 (81361)	ea	1									B-1	20
C	PA FZ Z 5305-639-2221	SCREW, EXTERNALLY RELIEVED BODY  A81-1-4947 (81361)	ea	1									B-1	21
C	PA FZ Z 5360-347-2407	SPRING, HELICAL COMPRESSION  C81-1-4946 (81361)	ea	1									B-1	22
C	PA FZ Z 1040-739-2108	LATCH, SHIELD  B81-1-4945 (81361)	ea	1									B-1	23
C	PB FZ Z 1040-739-2106	PIN ASSEMBLY IGNITION  A81-1-4942 (81361)	ea	1									B-1	24



TM 3-1040-204-14

Section VI. REPAIR PARTS LIST - Continued

(1) SMR CODE	(2) FEDERAL STOCK NUMBER	(3) DESCRIPTION  <i>Reference Number &amp; Mfr. Code</i> <i>Usable on Code</i>	(4) UNIT OF MEAS	(5) QTY INC IN UNIT	(6) 30-DAY ES MAINT ALLOWANCE			(7) 30-DAY GS MAINT ALLOWANCE			(8) 1-YR ALW PER 100 EQUIP CNTGTY	(9) DEPOT MAINT ALW PER 100 EQUIP	(10) ILLUSTRATION	
					(a)	(b)	(c)	(a)	(b)	(c)			(a)	(b)
					1-20	21-50	51-100	1-20	21-50	51-100			FIGURE NO.	ITEM NO.
C	PB HZ Z 5730-973-1207	PACKING, PREFORMED  mounted chevron type packing mater- ial, polymerized tetra fluoroethyl- ene, pressure range of 300 to 500 psi, 5/8 - 1/64 od, x 1/4 + 1/64 id x .150 stack ht, chevron angle 120 degrees  410 (71724)	ea	2									B-2	7
C	PA HZ Z 3120-662-0701	BEARING, SLEEVE  B81-1-4962 (81361)	ea	1									B-2	8
C	PA HZ Z 5310-292-9876	WASHER, FLAT  A81-1-4981 (81361)	ea	1									B-2	9
C	PA HZ Z 1040-347-2433	BODY, INLET  C81-1-4948 (81361)	ea	1									B-2	10



TM 3-1040-204-14  
Section VI. REPAIR PARTS LIST - Continued

(1) SMR CODE	(2) FEDERAL STOCK NUMBER	(3) DESCRIPTION  Reference Number & Mfr. Code      Usable on Code	(4) UNIT OF MEAS	(5) QTY INC IN UNIT	(6) 30-DAY DS MAINT ALLOWANCE			(7) 90-DAY GS MAINT ALLOWANCE			(8) 1-YR ALW PER EQUIP CNTRY	(9) DEPOT MAINT ALW PER EQUIP	(10) ILLUSTRATION	
					(a)	(b)	(c)	(a)	(b)	(c)			(a)	(b)
					1-20	21-50	51-100	1-20	21-50	51-100			FIGURE NO.	ITEM NO.
C	PA FZ Z 1040-347-2419	LEVER ASSEMBLY VALVE B81-1-4973 (81361)	ea	1									B-3	3
C	PA FZ Z 5315-292-9739	PIN, STRAIGHT, HEADLESS A81-1-4969 (81361)	ea	1									B-3	4
C	PA FZ Z 1040-347-2415	LINK, VALVE B81-1-4968 (81361)	ea	1									B-3	5
C	PA FZ Z 1040-347-2414	GRIP ASSEMBLY, VALVE C81-1-6202 (81361)	ea	1									B-3	6
C	PA FZ Z 5315-292-9745	PIN, SHOULDER, HEADLESS A81-1-4974 (81361)	ea	1									B-3	7
C	PA FZ Z 1040-347-2417	LEVER, VALVE ASSEMBLY C81-1-4979 (81361)	ea	1									B-3	8
C	PA FZ Z 5306-639-0460	BOLT, MACHINE st1 B81-1-4978 (81361)	ea	1									B-3	9



TM 3-1040-204-14  
Section VI. REPAIR PARTS LIST - Continued

(1) SMR CODE	(2) FEDERAL STOCK NUMBER	(3) DESCRIPTION  Reference Number & Mfr. Code Usable on Code	(4) UNIT OF MEAS	(5) QTY INC IN UNIT	(6) 30-DAY DS MAINT ALLOWANCE			(7) 30-DAY GS MAINT ALLOWANCE			(8) 1-YR ALW PER 100 EQUIP CNTGCTY	(9) DEPOT MAINT ALW PER 100 EQUIP	(10) ILLUSTRATION	
					(a)	(b)	(c)	(a)	(b)	(c)			(a)	(b)
					1-20	21-50	51-100	1-20	21-50	51-100			FIGURE NO.	ITEM NO.
C	PA FZ Z 4720-839-3423	HOSE ASSEMBLY, NONMETALLIC B81-1-6930 (81361)	ea	1									B-4	1
C	PA FZ Z 4730-541-7288	COUPLING HALF, QUICK-DISCONNECT B81-1-2856 (81361) GROUP 300 - TANK GROUP	ea	1									B-4	2
C	AF FZ Z	TANK ASSEMBLY, FUEL, PORTABLE, FLAME THROWER, M2A1-7 E81-1-482 (81361)	ea	1									B-5	
													B-6	
													B-7	
													B-8	
C	PB OH Z 1040-784-9218	PLUG ASSEMBLY, FILLING D81-1-4883 (81361)	ea	2									B-5	1
C	PA OZ Z 5330-265-1092	PACKING, PREFORMED synthetic rubber, cross-sectional dim. 0.145 in. max, cross-sectional H, 1.302 in. max. center hole dia. MS29513-219 (96906)	ea	2									B-5	2



TM 3-1040-204-14  
Section VI. REPAIR PARTS LIST - Continued

(1) SMR CODE	(2) FEDERAL STOCK NUMBER	(3) DESCRIPTION  Reference Number & Mfr. Code      Usable on Code		(4) UNIT OF MEAS	(5) QTY INC IN UNIT	(6) 30-DAY DS MAINT ALLOWANCE			(7) 30-DAY GS MAINT ALLOWANCE			(8) 1-YR ALW PER 100 EQUIP CNTGCT	(9) DEPOT MAINT ALW PER 100 EQUIP	(10) ILLUSTRATION	
						(a)	(b)	(c)	(a)	(b)	(c)			(a)	(b)
						1-20	21-50	51-100	1-20	21-50	51-100			FIGURE NO.	ITEM NO.
C	PB FZ Z 5320-068-6929	RIVET, SOLID  universal hd, stl, 3/16 in. nom dia,  1 1/8 in. nom lg  MS20613-6P18 (96906)		ea	1									B-5	3
C	PB FZ Z 1040-568-9676	TUBE, REGULATOR AND SOCKET  B81-1-1795 (81361)		ea	1									B-6	1
C	PB HH Z 4730-529-2366	COUPLING HALF, QUICK-DISCONNECT  3000-63 (73992)		ea	1									B-6	2
C	PB OZ Z 5310-209-2652	NUT, PLAIN, WING,  1/4-20 UNC-2B  A81-1-877 (81361)		ea	1									B-6	3
C	PB OH H 1040-293-5891	TANK AND VALVE PRESSURE  B81-1-879 (81361)		ea	1									B-6	4
C	PB FF Z 1040-160-8027	SHAFT ASSEMBLY, VALVE  C81-1-883 (81361)		ea	1									B-6	5



TM 3-1040-204-14

Section VI. REPAIR PARTS LIST - Continued

(1) SMR CODE	(2) FEDERAL STOCK NUMBER	(3) DESCRIPTION  Reference Number & Mfr. Code Usable on Code	(4) UNIT OF MEAS	(5) QTY INC IN UNIT	(6) 30-DAY DS MAINT ALLOWANCE			(7) 30-DAY OS MAINT ALLOWANCE			(8) 1-YR ALW PER 100 EQUIP CNTGCTY	(9) DEPOT MAINT ALW PER 100 EQUIP	(10) ILLUSTRATION	
					(a)	(b)	(c)	(a)	(b)	(c)			(a) FIGURE NO.	(b) ITEM NO.
					1-20	21-50	51-100	1-20	21-50	51-100				
C	PB FZ Z 1040-160-8018	VALVE SAFETY  C81-1-1796 (81361)	ea	1									B-7	3
C	PB FH H 1040-160-8050	REGULATOR, PRESSURE  C81-1-778 (81361)	ea	1									B-7	4
C	PB HZ Z 1040-160-8036	VALVE, NEEDLE  20517 (26505)	ea	1									B-7	5
C	PB HZ Z 4820-647-1870	VALVE, NEEDLE  (5 per can)  20519 (26505)	ea	2									B-7	6
C	KF HZ Z	GROMMET, FLANGE  024-00101 (26205)	ea	1	See Kit	1040-300-0014							B-7	7
C	KF HZ Z	DIAPHRAGM  090-02006 (26205)	ea	1	See Kit	1040-300-0014							B-7	8
C	KF HZ Z	PLATE, DIAPHRAGM  51968 (26505)	ea	1	See Kit	1040-300-0014							B-7	9

TM 3-1040-204-14  
Section VI. REPAIR PARTS LIST - Continued

(1) SMR CODE	(2) FEDERAL STOCK NUMBER	(3) DESCRIPTION  Reference Number & Mfr. Code      Usable on Code	(4) UNIT OF MEAS	(5) QTY INC IN UNIT	(6) 30-DAY DS MAINT ALLOWANCE			(7) 30-DAY GS MAINT ALLOWANCE			(8) 1-YR ALW PER 100 EQUIP CNTCTY	(9) DEPOT MAINT ALW PER 100 EQUIP	(10) ILLUSTRATION	
					(a)	(b)	(c)	(a)	(b)	(c)			(a)	(b)
					1-20	21-50	51-100	1-20	21-50	51-100			FIGURE NO.	ITEM NO.
C	KF HZ Z	SPRING, HELICAL COMPRESSION  20908 (26205)	ea	1	See	Kit	1040-300-0014						B-7	10
C	PB HZ Z 4730-826-0093	NIPPLE, PIPE  stl, cres, 1/4-18 NPT. <u>1-4 x 7-8</u>  <u>type 316 (88216)</u>	ea	1									B-7	11
C	PB HZ Z 5305-866-0439	SCREW, MACHINE  fillister hd, slot drive, stl, pltd,  1/4-20 UNC, 1.500 in. lg  MS35265-85 (96906)	ea	8									B-7	12
C	PB HZ Z 4730-639-9347	ADAPTER, STRAIGHT, PIPE TO TUBE  24960 (26505)	ea	1									B-7	13
C	PB HZ Z 5315-160-8042	PIN, SHOULDER, HEADLESS  <b>261101 (26505)</b>	ea	1									B-7	14
C	KF HZ Z	GASKET  fiber bituminized  72525 (26505)	ea	1	See	Kit	1040-829-1771						B-7	15

TM 3-1040-204-14

Section VI. REPAIR PARTS LIST - Continued

(1) SMR CODE	(2) FEDERAL STOCK NUMBER	(3) DESCRIPTION  Reference Number & Mfr. Code Usability Code	(4) UNIT OF MEAS.	(5) QTY INC IN UNIT	(6) 30-DAY MS MAINT ALLOWANCE			(7) 60-DAY MS MAINT ALLOWANCE			(8) 1-YR AW PER 100 EQUIP CMTGCV	(9) DEPOT MAINT AW PER 100 EQUIP	(10) ILLUSTRATION	
					(a)	(b)	(c)	(d)	(e)	(f)			(a) FIGURE NO.	(b) ITEM NO.
					1-20	21-50	51-100	1-20	21-50	51-100				
C	KF HZ Z	SEAT ASSEMBLY, VALVE 234616 (26505)	ea	1	See Kit	1040-829-1771							B-7	16
C	PB HZ Z	4730-972-7670 STRAINER 104-00022 (93465)	ea	1									B-7	17
C	PB HZ Z	4820-611-6803 VALVE N743PC12 (26505)	ea	1									B-7	18
C	PB HZ Z	5360-205-4458 SPPING, HELICAL COMPRESSION 22128 (26505)	ea	1									B-7	19
C	KF HZ Z	PACKING, PREFORMED MS28775-213 (96906)	ea	1	See Kit	1040-329-1771							B-7	20
C	XB HZ Z	5365-984-8861 PLUG, MACHINE THREAD 51438 (26505) CARRIER SECTION	ea	1									B-7	21
C	PA OZ Z	1040-205-0358 STRAP ASSEMBLY, UPPER B81-1-520 (81361)	ea	2									B-8	1



TM 3-1040-204-14

Section VI. REPAIR PARTS LIST - Continued

(1) SMR CODE	(2) FEDERAL STOCK NUMBER	(3) DESCRIPTION  Reference Number & Mfr. Code Usable on Code	(4) UNIT OF MEAS	(5) QTY INC IN UNIT	(6) 30-DAY DS MAINT ALLOWANCE			(7) 30-DAY GS MAINT ALLOWANCE			(8) 1-YR ALW PER 100 EQUIP CNTGCT	(9) DEPOT MAINT ALW PER 100 EQUIP	(10) ILLUSTRATION	
					(a) 1-20	(b) 21-50	(c) 51-100	(a) 1-20	(b) 21-50	(c) 51-100			(a) FIGURE NO.	(b) ITEM NO.
					C	PB FZ Z 5310-761-6882	NUT, PLAIN, HEXAGON st1, pltd, 1/4-20 UNC-2B MS51967-2 (96906)	ea	5					
C	PA OZ Z 1040-205-0360	STRAP ASSEMBLY B81-1-519 (81361)	ea	1									B-8	8
C	PA OZ Z 1040-205-0361	STRAP ASSEMBLY, LOWER B81-1-520 (81361)	ea	2									B-8	9
C	PB OZ Z 4020-993-3583	CORD, NYLON 9 carriers per braid, 1 yarn per carrier, single yarn, olive drab, 1/8 in. nom dia, 400 lb breaking strength MIL-C-4330-7 (81349)	ft	12									B-8	10

TM 3-1040-204-14  
Section VI. REPAIR PARTS LIST - Continued

(1) SMR CODE	(2) FEDERAL STOCK NUMBER	(3) DESCRIPTION  <i>Reference Number &amp; Mfr. Code</i> <i>Uskhhn Code</i>	(4) UNIT OF MEAS	(5) QTY INC IN UNIT	(6) 30-DAY DS MAINT ALLOWANCE			(7) 30-DAY GS MAINT ALLOWANCE			(8) 1-YR ALW PER 100 EQUIP CNTGCTY	(9) DEPOT MAINT ALW PER 100 EQUIP	(10) ILLUSTRATION	
					(a)	(b)	(c)	(a)	(b)	(c)			(a)	(b)
					1-20	21-50	51-100	1-20	21-50	51-100			FIGURE NO.	ITEM NO.
C	PB FZ Z 5340-160-8065	CLAMP, LOOP  stl pltd, 1/2 in. w o/a 0.0598 in. thk, 1-1/16 in. loop id, 9/32 in. dia of hole (5 per bundle) A81-1-487 (81361)	ea	1									B-8	11
C	PB FZ Z 5305-068-0502	SCREW, CAP, HEXAGON HEAD  stl, pltd, 1/4-20 UNC-2A, 3/4 in. lg MS90725-6 (96906)	ea	1									B-8	12
C	PB FH H 1040-160-8063	FRAME, CARRIER  D81-1-504 (81361)	ea	1									B-8	13
C	PA OZ Z 1040-205-0359	STRAP ASSEMBLY, SHORT  B81-1-519 (81361)	ea	1									B-8	14

TM 3-1040-204-14  
Section VI. REPAIR PARTS LIST - Continued

(1) SMR CODE	(2) FEDERAL STOCK NUMBER	(3) DESCRIPTION  Reference Number & Mfr. Code Usable on Code	(4) UNIT OF MEAS	(5) QTY INC IN UNIT	(6) 90-DAY DS MAINT ALLOWANCE			(7) 90-DAY GS MAINT ALLOWANCE			(8) 1-YR ALW PER 100 EQUIP CNTGCTY	(9) DEPOT MAINT ALW PER 100 EQUIP	(10) ILLUSTRATION	
					(a) 1-20	(b) 21-50	(c) 51-100	(a) 1-20	(b) 21-50	(c) 51-100			(a) FIGURE NO.	(b) ITEM NO.
		GROUP 400 - ACCESSORIES												
C	XB FZ Z	CHEST PACKING E116-3-42 (81361)	ea	1										
		GROUP 500 - REPAIR KIT GROUP												
C	PB HZ Z	1040-300-0014 REPAIR KIT, PRESSURE CONTROL R81-1-4904 (81361)	ea	1									KIT	
		1 ea - GROMMET, FLANGE											B-7	7
		1 ea - DIAPHRAGM											B-7	8
		1 ea - PLATE DIAPHRAGM											B-7	9
		1 ea - SPRING, HELICAL COMPRESSION											B-7	10
C	PB HZ Z	1040-829-1771 PARTS KIT, PRESSURE REGULATOR, FLAME THROWER NOREF (33333)	ea	1									KIT	
		2 ea - GASKET, fiber bituminized											B-7	15
		1 ea - SEAT, ASSEMBLY VALVE											B-7	16
		1 ea - PACKING, PREFORMED											B-7	20

Section VIII. INDEX - FEDERAL STOCK NUMBER AND REFERENCE NUMBER  
 CROSS-REFERENCE TO FIGURE AND ITEM NUMBER

<u>Stock Number</u>	<u>Figure No.</u>	<u>Item No.</u>	<u>Stock Number</u>	<u>Figure No.</u>	<u>Item No.</u>
5310-761-6882	B-8	7	5360-347-2408	B-1	7
5315-160-8042	B-7	14	5360-347-2409	B-1	8
5315-292-9734	B-1	13	5365-984-8861	B-7	21
5315-292-9739	B-3	4	5730-973-1207	B-2	7
5315-292-9742	B-1	14			
5315-292-9745	B-3	7			
5315-663-1478	B-8	4			
5315-842-3044	B-8	3			
5320-068-6929	B-5	8			
5330-045-1990	B-2	6			
5330-202-4249	B-5	5			
5330-265-1092	B-5	2			
5340-160-8065	B-8	11			
5340-160-8078	B-1	6			
5340-205-4458	B-7	19			
5340-596-5923	B-2	13			
5360-347-2405	B-2	4			
5360-347-2406	B-2	5			
5360-347-2407	B-1	22			

## APPENDIX C

### MAINTENANCE ALLOCATION CHART

---

#### Section I. INTRODUCTION

##### C-1. General

The maintenance allocation chart (sec. II) lists the authorized maintenance functions assigned the maintenance categories for maintenance of the M2A1-7 portable flamethrower. This chart is to be used by all levels of maintenance to insure complete support of the equipment.

##### C-2. Maintenance Functions

Maintenance functions authorized are limited to and defined as follows:

- a. Inspect.* To determine the serviceability of an item by comparing its physical, mechanical and/or electrical characteristics with established standards through examination.
- b. Test.* To verify serviceability and to detect incipient failure by measuring the mechanical or electrical characteristics of an item and comparing those characteristics with prescribed standards.
- c. Servicing.* Operations required periodically to keep an item in proper operating conditions, i.e., to clean, preserve, drain, paint, or to replenish fuel, lubricants, hydraulic fluids, or compressed air supplies.
- d. Adjust.* To maintain, within prescribed limits, by bringing into proper or exact position, or by setting the operating characteristics to specified parameters.
- e. Align.* To adjust specified variable elements of an item to bring about optimum or desired performance.
- f. Calibrate.* To determine and cause corrections to be made or to be adjusted on instruments or test measuring and diagnostic equipments used in precision measurement. Consists of comparisons of two instruments, one of which is a certified standard of known accuracy, to detect and adjust any discrepancy in the accuracy of the instrument being compared.
- g. Install.* The act of emplacing, seating, or fixing into position an item, part, or module (component or assembly) in a manner to allow the proper functioning of an equipment or system.
- h. Replace.* The act of substituting a serviceable like-type part, subassembly, module (component or assembly) in a manner to allow the proper functioning of an equipment system.
- i. Repair.* The application of maintenance services (inspect, test, service, adjust, align, calibrate, replace) or other maintenance actions (welding, grinding, riveting, straightening, facing, remachining, or resurfacing) to restore serviceability to an item by correcting specific damage, fault, malfunction, or failure in a part, subassembly, module/component/assembly, end item or system.
- j. Overhaul.* That maintenance effort (service/action) necessary to restore an item to a completely serviceable/operational condition as prescribed by maintenance standards (e.g., DMWR) in pertinent technical publications. Overhaul is normally the highest degree of maintenance performed by the Army. Overhaul does not normally return an item to like new condition.
- k. Rebuild.* Consists of those services/actions necessary for the restoration of unserviceable equipment to a like-new condition in accordance with original manufacturing standards. Rebuild is the highest degree of materiel maintenance applied to Army equipment. The rebuild operation includes the act of returning to zero those age measurements (hours, miles, etc.) considered in classifying Army equipment/components.
- l. Symbols.* The uppercase letter placed in the appropriate column indicates the lowest level at which that particular maintenance function is to be performed.

##### C-3. Explanation of Format

Purpose and use of the format are as follows:

a. *Column 1, Group Number.* Column 1 lists group numbers, the purpose of which is to match components, assemblies, subassemblies, and modules with the next higher assembly.

b. *Column 2, Functional Group.* Column 2 lists the next higher assembly group and the item names of components, assemblies, subassemblies, and modules within the group for which maintenance is authorized.

c. *Column 3, Maintenance Function.* Column 3 lists the eleven maintenance functions defined in C-2 above. Each maintenance function required for an item shall be specified by the symbol among those listed in d below which indicates the level responsible for the required maintenance. Under this symbol, there shall be listed an appropriate work measurement time value as indicated in e below.

d. *Use of Symbols.* The following symbols are used to prescribe work function responsibility:

<i>Symbol</i>	<i>Explanation</i>
C .....	Operation/crew maintenance
O .....	Organizational maintenance

<i>Symbol</i>	<i>Explanation</i>
F .....	Direct support maintenance
H .....	General support maintenance
D .....	Depot maintenance

e. *Work Measurement Time.* The active repair time required to perform the maintenance function is included directly below the symbol identifying the category of maintenance. Active repair time is the average aggregate time required to restore an item (subassembly, assembly, component, module, end item, or system) to a serviceable condition under typical field operating conditions. This time includes preparation time, fault isolation/diagnostic time, and QA/QC time in addition to the time required to perform specific maintenance functions identified for the tasks authorized in the maintenance allocation chart. This time is expressed in man-hours and carried to one decimal place (tenths of hours).

f. *Column 4, Tools and Equipment.* Column 4 lists those peculiar tools and test, measuring, diagnostic, and support equipment used in performing the authorized maintenance functions.

g. *Column 5, Remarks.* Self-explanatory.



(1) GROUP NUMBER	(2) FUNCTIONAL GROUP COMPONENT ASSEMBLY NOMENCLATURE	(3) MAINTENANCE FUNCTION										(4) TOOLS AND EQUIPMENT	(5) REMARKS	
		INSPECT	TEST	SERVICE	ADJUST	ALIGN	CALIBRATE	INSTALL	REPLACE	REPAIR	OVERHAUL			REBUILD
	Pack Carrier	O		O					O					
	Frame Carrier	0.1		0.5					0.2					
		O						F	H					
		0.1						0.3	0.5					

Section VIII. INDEX - FEDERAL STOCK NUMBER AND REFERENCE NUMBER  
CROSS-REFERENCE TO FIGURE AND ITEM NUMBER

<u>Reference No.</u>	<u>Mfg Code</u>	<u>Fig No.</u>	<u>Item No.</u>	<u>Reference No.</u>	<u>Mfg Code</u>	<u>Fig No.</u>	<u>Item No.</u>
AN935416	88044	B-8	6	B81-1-1795	81361	B-6	1
A81-1-2704	81361	B-7	2	B81-1-2146	81361	B-6	8
A81-1-4573	81361	B-5	5	B81-1-2856	81361	B-4	2
A81-1-460	81361	B-1	6	B81-1-439	81361	B-6	7
A81-1-487	81361	B-8	11	B81-1-444	81361	B-1	2
A81-1-4932	81361	B-1	13	B81-1-4927	81361	B-1	16
A81-1-4939	81361	B-1	14	B81-1-4928	81361	B-1	19
A81-1-4942	81361	B-1	24	B81-1-4938	81361	B-1	15
A81-1-4947	81361	B-1	21	B81-1-4945	81361	B-1	23
A81-1-4958	81361	B-2	12	B81-1-4952	81361	B-2	1
A81-1-4959	81361	B-2	13	B81-1-4961	81361	B-2	2
A81-1-4969	81361	B-3	4	B81-1-4962	81361	B-2	8
A81-1-4974	81361	B-3	7	B81-1-4963	81361	B-2	5
A81-1-4977	81361	B-3	12	B81-1-4968	81361	B-3	5
A81-1-4981	81361	B-2	9	B81-1-4973	81361	B-3	3
A81-1-4984	81361	B-1	9	B81-1-4978	81361	B-3	9
A81-1-4985	81361	B-2	3	B81-1-514	81361	B-5	6
A81-1-518	81361	B-8	4	B81-1-519	81361	B-8	8
A81-1-519	81361	B-8	14	B81-1-520	81361	B-8	1
A81-1-877	81361	B-6	3	B81-1-520	81361	B-8	9

TM 3-1040-204-14

Section VIII. INDEX - FEDERAL STOCK NUMBER AND REFERENCE NUMBER  
CROSS-REFERENCE TO FIGURE AND ITEM NUMBER

<u>Reference No.</u>	<u>Mfg Code</u>	<u>Fig No.</u>	<u>Item No.</u>	<u>Reference No.</u>	<u>Mfg Code</u>	<u>Fig No.</u>	<u>Item No.</u>
B81-1-6930	81361	B-4	1	C81-1-873	81361	B-8	2
B81-1-6949	81361	B-2	6	C81-1-883	81361	B-6	5
B81-1-879	81361	B-6	4	D81-1-4581	81361	B-5	4
B81-1-885	81361	B-6	6	D81-1-4883	81361	B-5	1
C81-1-1573	81361	B-5	7	D81-1-4920	81361	B-1	
C81-1-1796	81361	B-7	3			B-2	
C81-1-375	81361	B-6	9			B-3	
C81-1-4921	81361	B-1	1	D81-1-4922	81361	B-1	5
C81-1-4931	81361	B-1	12	<b>D81-1-4924</b>	81361	B-1	11
C81-1-4943	81361	B-1	8	D81-1-4966	81361	B-3	2
C81-1-4944	81361	B-1	7	D81-1-504	81361	B-8	13
C81-1-4946	81361	B-1	22	E116-3-42	81361		
C81-1-4948	81361	B-2	10	E81-1-482	81361	B-5	
C81-1-4964	81361	B-2	4			B-6	
C81-1-4979	81361	B-3	8			B-7	
C81-1-4980	81361	B-3	11			B-8	
C81-1-6201	81361	B-1	20	E81-1-483	81361	B-5	3
C81-1-6202	81361	B-3	6	E81-1-561	81361	B-7	1
C81-1-7001	81361	B-4		MIL-C-43307	81349	B-8	10
C81-1-778	81361	B-7	4	MS20613-6P18	96906	B-5	8

TM 3-1040-204-14

Section VIII. INDEX - FEDERAL STOCK NUMBER AND REFERENCE NUMBER  
CROSS-REFERENCE TO FIGURE AND ITEM NUMBER

Reference No.	Mfg Code	Fig No.	Item No.	Reference No.	Mfg Code	Fig No.	Item No.
MS24665-283	96906	B-8	3	090-02006	26205	B-7	8
MS28775-213	96906	B-7	20	<b>104-00022</b>	93465	B-7	17
MS29513-219	96906	B-5	2	1/4 x 7/8			
MS35206-241	96906	B-1	3	type 316	88216	B-7	11
		B-1	17	<b>20517</b> 20519	<b>26505</b> 26505	<b>B-7</b> B-7	<b>5</b> 6
MS35207-279	96906	B-2	11	20908	26205	B-7	10
MS35265-46	96906	B-3	1	22128	26505	B-7	19
MS35265- <b>64</b>	96906	B-1	10	234616	26505	B-7	16
				24960	26505	B-7	13
MS35265-85	96906	B-7	12				
MS35338-42	96906	B-1	4	26110	26505	B-7	14
		B-1	<b>18</b>	3000-63	73992	B-6	2
MS51966-26	96906	B-3	10	410	71724	B-2	7
MS51967-2	96906	B-8	7	51438	26505	B-7	21
MS90725-5	96906	B-8	5	51968	26505	B-7	9
MS90725-6	96906	B-8	12	72525	26505	B-7	15
NOREF	33333	KIT					
N743PC12	26505	B-7	18				
R81-1-4904	81361	KIT					
024-00101	26205	B-7	7				

TM 3-1040-204-14

Section VIII. INDEX - FEDERAL STOCK NUMBER AND REFERENCE NUMBER  
CROSS-REFERENCE TO FIGURE AND ITEM NUMBER

<u>Stock Number</u>	<u>Figure No.</u>	<u>Item No.</u>	<u>Stock Number</u>	<u>Figure No.</u>	<u>Item No.</u>
1040-160-8011	B-6	8	1040-347-2412	B-3	2
1040-160-8014	B-5	7	1040-347-2414	B-3	6
1040-160-8018	B-7	3	1040-347-2415	B-3	5
1040-160-8027	B-6	5	1040-347-2416	B-3	12
			1040-347-2417	B-3	8
1040-160-8036	B-7	5	1040-347-2419	B-3	3
1040-160-8050	B-7	4	1040-347-2420	B-2	12
1040-160-8063	B-8	13	1040-347-2421	B-1	19
1040-160-8068	B-5	3	1040-347-2427	B-1	5
1040-160-8082	B-1	2	1040-347-2429	B-1	1
1040-160-8083	B-6	7	1040-347-2431	B-1	20
1040-205-0358	B-8	1	1040-347-2432	B-1	11
1040-205-0359	B-8	14	1040-347-2433	B-2	10
1040-205-0360	B-8	8	1040-347-3883	B-2	2
1040-205-0361	B-8	9	1040-347-3889	B-2	1
1040-293-5891	B-6	4	1040-568-9676	B-6	1
1040-300-0014	KIT		1040-696-1374	B-8	2
1040-347-2410	B-3	11	1040-739-2104	B-1	15
1040-347-2411	B-1		1040-739-2105	B-1	12
	B-2		1040-739-2106	B-1	24
	B-3		1040-739-2107	B-1	16

Section **VIII**. INDEX - FEDERAL STOCK NUMBER AND REFERENCE NUMBER  
CROSS-REFERENCE TO FIGURE AND ITEM NUMBER

<u>Stock Number</u>	<u>Figure No.</u>	<u>Item No.</u>	<u>Stock Number</u>	<u>Figure No.</u>	<u>Item No.</u>
1040-739-2108	B-1	23	5305-614-0245	B-1	10
1040-752-7955	B-7	1		B-3	13
1040-784-9218	B-5	1	5305-622-9476	B-3	1
1040-829-1771	KIT		5305-639-2221	B-1	21
3120-662-0701	B-2	8	5305-724-7275	B-3	10
4020-993- <b>3583</b>	B-8	10	5305-866-0439	B-7	12
4720-839-3423	B-4	1	5305-984-6189	B-1	3
4730-160-8025	B-6	6		B-1	17
4730-160-8062	B-5	6	5305-993-2463	B-2	11
4730-377-9421	B-5	4	5306-639-0460	B-3	9
4730-529-2366	B-6	2	5310-045-3299	B-1	4
4730-541-7288	B-4	2		B-1	18
4730-639-9347	B-7	13	5310-209-2652	B-6	3
4730-826-0093	B-7	11	5310-292-1501	B-7	2
4730-972-7670	B-7	17	5310-292-9876	B-2	9
4820-611-6803	<b>B-7</b>	18	5310-582-5965	B-8	6
<b>4820-647-1870</b>	<b>B-7</b>	6			
5305-068-0501	B-8	5	5310-596-0133	B-2	3
5305-068-0502	B-8	12	5310-596-0134	B-1	9

## INDEX

	Paragraph	Page		Paragraph	Page
Adjusting—Pressure Regulator .....	5-14	5-8	Packing Chest .....	5-16	5-9
Administrative Storage .....	7-2	7-1	Painting Instructions .....	4-9	4-2
After-Firing Procedure .....	2-11	2-2	Preparing Flamethrower for Test .....	6-3	6-1
After-Operation Services .....	4-17	4-5	Preparing Flamethrower for Use .....	2-8	2-1
Aiming .....	2-11 <i>e</i>	2-3	Pressure Regulator .....	6-10	6-8
Air Pressure Tank .....	1-6 <i>a</i>	1-1	Pressure Regulator—Adjusting .....	5-14	5-8
Air Pressure Tank and Fuel Tanks .....	4-7	4-2	Pressure Regulator and Safety Valve .....	5-10	5-6
Barrel Assembly .....	6-6	6-5	Pressure Regulator and Tube As- sembly .....	1-6 <i>a</i>	1-1
Basic Issue Item List .....	App B	B-1	Pressure Tank and Fuel Tanks .....	1-6	1-1
Before Issuing Flamethrower .....	4-16	4-5	Pressure Tank and Valve Assembly .....	1-6 <i>a</i> ,	1-1
Before-Operating Inspection .....	3-2	3-1	4-25	4-9	
Carrier Frame .....	5-15	5-9	Pressure Tanks .....	1-6 <i>b</i>	1-5
Carrier Pack .....	1-6 <i>b</i> (3), 4-24 <i>a</i>	1-5, 4-8	Pressure Tank Safety .....	6-9	6-5
Carrying Instructions .....	2-9	2-2	Pressure Tank Valve Handle .....	2-1	2-1
Charging Air Pressure Tank .....	4-12 <i>b</i>	4-3	Pressure Testing Pressure Tank .....	4-12 <i>a</i>	4-3
Check Valve Assembly .....	5-13	5-8	Preventive Maintenance Checks and Services .....	3-3,	3-1
Climatic Extremes .....	2-13	2-4	3-4,	4-5	
Connecting Gun and Hose Assembly .....	4-6	4-2	4-15		
Coupling Plug .....	2-6	2-1	Quick-Disconnect Coupling Assembly .....	6-8	6-5
Coupling Plug and Gasket .....	4-23	4-8	Quick-Disconnect Coupling Half .....	5-6	5-5
Destruction to Prevent Enemy Use .....	7-3, 7-7	7-1	Record and Report Forms .....	1-2	1-1
Description .....	1-3	1-1	References .....	App A	A-1
Expendable Items .....	4-26	4-9	Regulator Tube Assembly .....	5-11	5-6
Filling Fuel Tanks .....	4-11	4-3	Removal of Protective Material .....	4-5	4-2
Filling Plug .....	1-6 <i>b</i>	1-5	Repacking Flamethrower .....	4-18	4-6
Filling Plug Assembly and Preformed Packing .....	4-22	4-7	Replacing Pressure Tank .....	4-13 <i>b</i>	4-3
Firing .....	2-11 <i>f</i>	2-3	Safety Head and Gasket .....	5-9	5-6
Firing Position .....	2-11 <i>c</i>	2-3	Safety Valve .....	1-6 <i>a</i> ,	1-1,
Firing Procedures .....	2-11	2-2	5-10	5-6	
Fuel Hose .....	5-5	5-5	Scope .....	1-1	1-1
Fuel Tanks .....	1-6 <i>b</i> ,	1-5,	Service Life .....	6-2 <i>b</i>	6-1
	5-7	5-5	Service Upon Receipt of Materiel .....	4-1	4-1
Functioning .....	1-10	1-8	Shipment .....	7-1	7-1
Gun .....	1-4,	1-1,	Snow or Rain .....	2-15	2-4
	5-2	5-1	Storage Life .....	6-2 <i>a</i>	6-1
High or Variable Winds .....	2-14	2-4	Storage Life and Service Life .....	4-4	4-2
Hinged Clamp .....	5-8	5-6	Strap Assemblies .....	4-24 <i>b</i>	4-9
Holding Device .....	6-9 <i>b</i>	6-7	Tabulated Data .....	1-9	1-8
Holding the Gun .....	2-11 <i>d</i>	2-3	Test Firing .....	6-4	6-1
Hose Assembly .....	1-5	1-1	Troop Installed Items .....	B-2	B-1
Hydrostatic and Volumetric Testing .....	4-3,	4-2	Troubleshooting .....	4-21	4-6
	6-1	6-1	Unpacking and Inspection .....	4-2	4-2
Identification Plates .....	1-7	1-5	Valve Grip Assembly .....	5-4	5-3
Ignition Cylinders .....	1-8	1-6	Valve Lapping Procedure .....	6-7	6-5
Ignition Grip Assembly .....	5-3	5-1	Valve Lever .....	2-3	2-1
Ignition Lever .....	2-5	2-1	Valve Safety Lever .....	2-2	2-1
Ignition Safety Lever .....	2-4	2-1	Valve Section .....	1-4 <i>a</i>	1-1
Lubricating Information .....	4-10	4-3	Valve Shaft .....	5-12	5-8
Lubrication .....	5-3 <i>b</i>	5-1	Valve Wrench .....	6-9 <i>b</i>	6-7
Needle Valve Assembly and Inlet Body .....	6-5	6-2	Venting Pressure Tank .....	4-13 <i>a</i>	4-3

By Order of the Secretary of the Army:

CREIGHTON W. ABRAMS  
*General, United States Army*  
*Chief of Staff*

Official:

VERNE L. BOWERS  
*Major General, United States Army*  
*The Adjutant General*

Distribution:

To be distributed in accordance with DA Form 12-28 (qty rqr block no. 53), Operator requirements for Portable Flamethrowers.