

# SOVIET CHEMICAL WEAPONS

an EOD examination

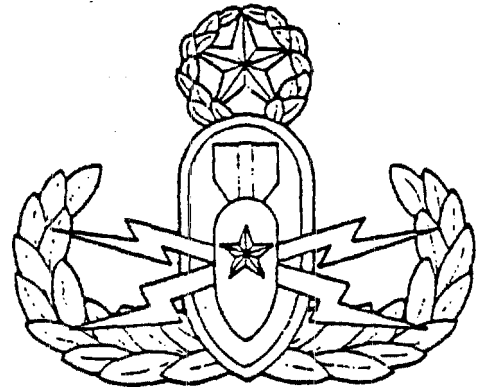

PRINT OR HANDWRITING  
NOT CONDUCTIVE FOR  
LEGIBLE CD IMAGING ON  
VARIOUS PAGES IN  
DOCUMENT.

**US ARMY ARMAMENT, MUNITIONS  
AND CHEMICAL COMMAND  
ARMAMENT RESEARCH, DEVELOPMENT  
AND ENGINEERING CENTER**

## INTRODUCTION

During October of 1987 the Soviet Union invited representatives of the foreign press as well as Western military experts to witness a display of chemical ammunition and the demilitarization procedures on selected chemical munitions at the Shikhany Military Facility. The items shown in the display included a grenade, projectiles, rockets, missiles, and bombs. Persons attending were permitted to take pictures from which most of our information comes. Whether all of the munitions shown were current or what part of the overall inventory was shown, is open to conjecture.

## PURPOSE

The purpose of this review of Shikhany is to look at selected ammunition items as they may pertain to EOD. It is hoped by doing this that the information gained will be useful in helping to identify the general characteristics of Soviet chemical munitions and to identify specific munitions. Our report will cover projectiles, and rockets. That portion pertaining to demil will not be discussed.

# MORTARS :

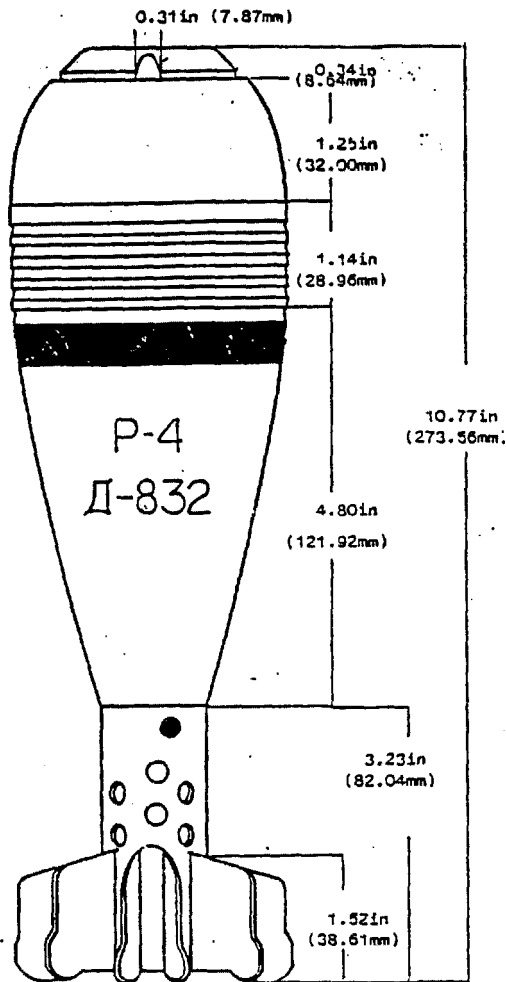

Mortar, 82-MM, Smoke, Model D-832

While these rounds were not shown in the Shikany chemical weapons display, there are reports of rounds of this caliber being used as chemical shells.

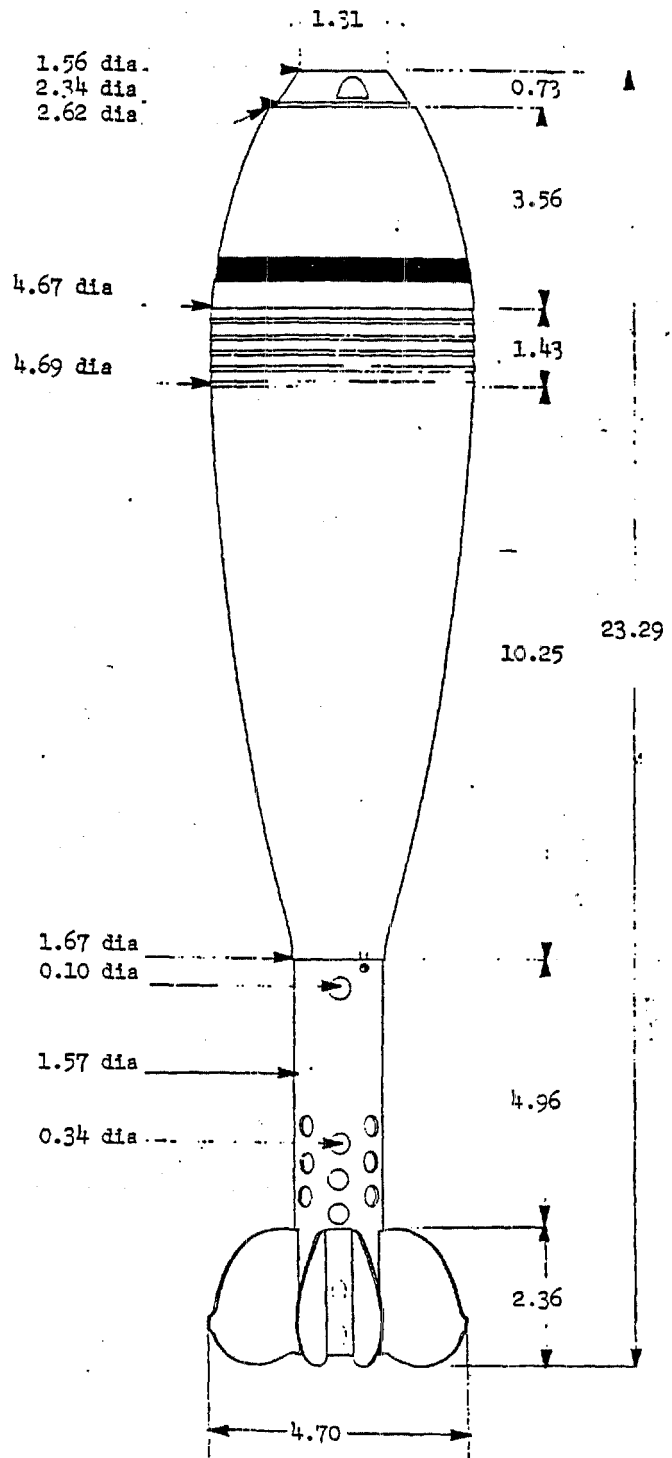

Mortar, 120-MM, Smoke, Model D5

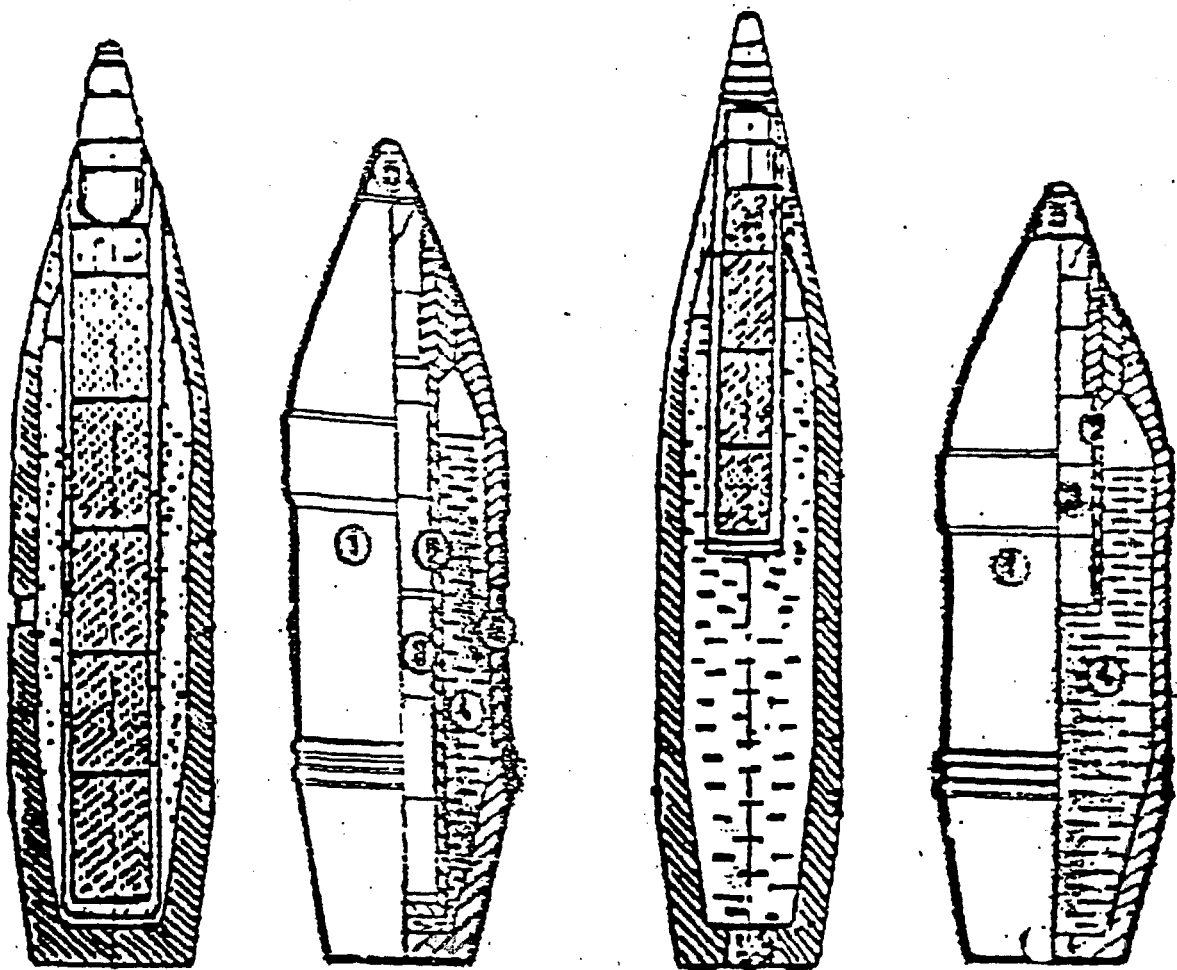

Illustrations from charts and booklets, showing long and short burster projectiles.

CAL	AGENT	PROJ WT		FUZE	ADAPTER	LONG BURSTER	SHORT BURSTER	FILLER PLUG IN REAR	FILLER PLUG IN SIDE
		AGENT	AGENT						
122mm	Sarin	22.2	1.3kg	PD	Yes	Yes			Yes
122mm	Thickened Lewisite	23.1	3.3kg	Airburst Time	Yes		Yes	Yes	
130mm	VX	33.4	1.4kg	Airburst Prox	Yes		Yes	Yes	
130mm	Sarin	33.4	1.6kg	PD	Yes	Yes			Yes
152mm	Thickened Lewisite	42.5	5.4kg	Airburst Time	Yes		Yes	Yes	
152mm	Sarin	40.0	2.8kg	PD	Yes	Yes			Yes

General data on chemical projectiles.

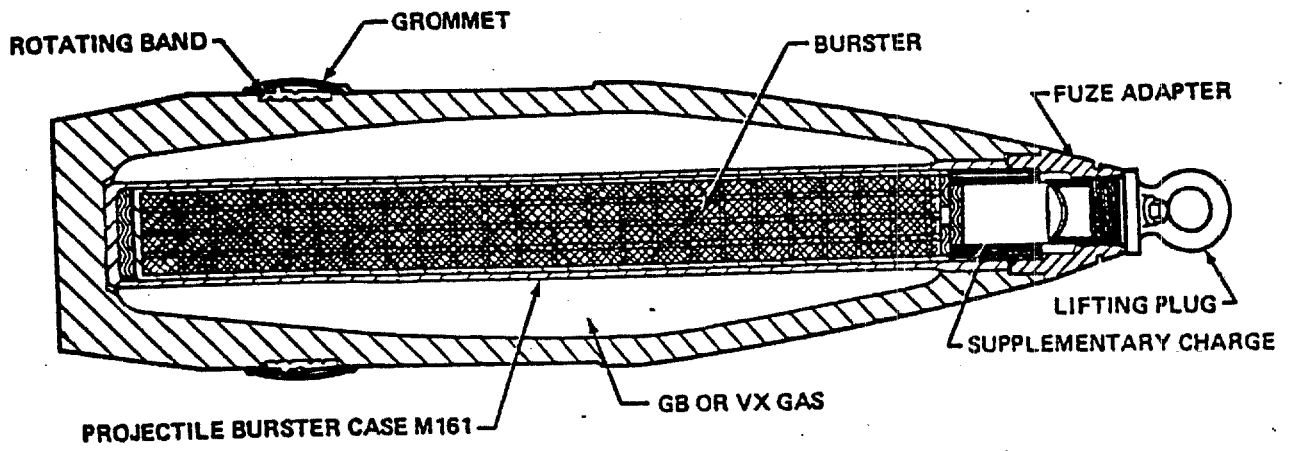

TYPICAL US CHEMICAL PROJECTILE

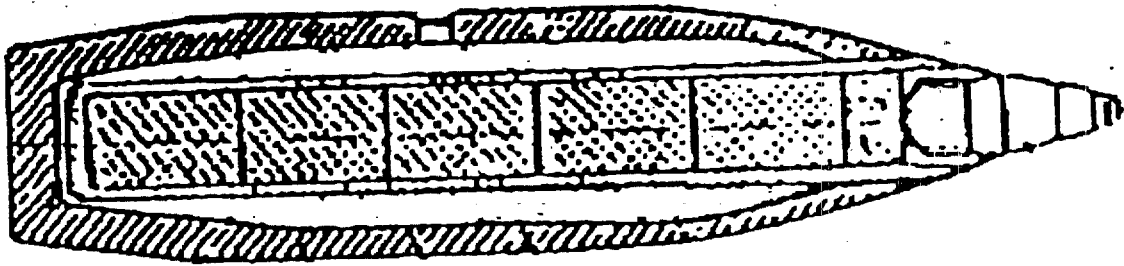

TYPICAL SOVIET CHEMICAL PROJECTILE NON-PERSISTANT AGENT

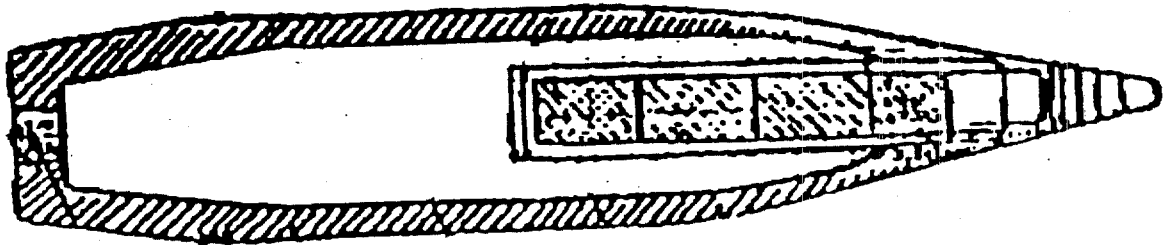

TYPICAL SOVIET CHEMICAL PROJECTILE PERSISTANT AGENT

FOREIGN ORDNANCE EOD IDENTIFICATION GUIDE

PROJECTILE, 122MM, CHEMICAL, (NON-PERSISTANT), MODEL UNKNOWN (USSR)

LENGTH EST: 498mm (19.61 in.)  
 DIAMETER: 122mm (4.80 in.)  
 LOADED WT: 22.20 kg (48.94 lb)  
 AGENT/WT: Sarin /1.30 kg (2.87 lb)  
 FILLER PLUG LOCATION: Side  
 BURSTER/CHARGE: Long/TNT  
 FUZE: PD, probably the RGM-2 or V-429  
 SPANNER HOLES: Two in adapter  
 SET SCREW HOLES: None  
 BASE COLOR: Gray  
 BANDS: Green (2)  
 MARKINGS: Green

COMMENTS: The projectile externally resembles the Model D-4 122mm smoke projectile. The markings shown are not believed to be the markings used on standard Soviet chemical munitions but are those used for display purposes.

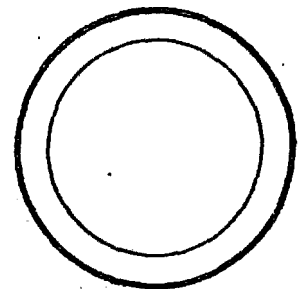
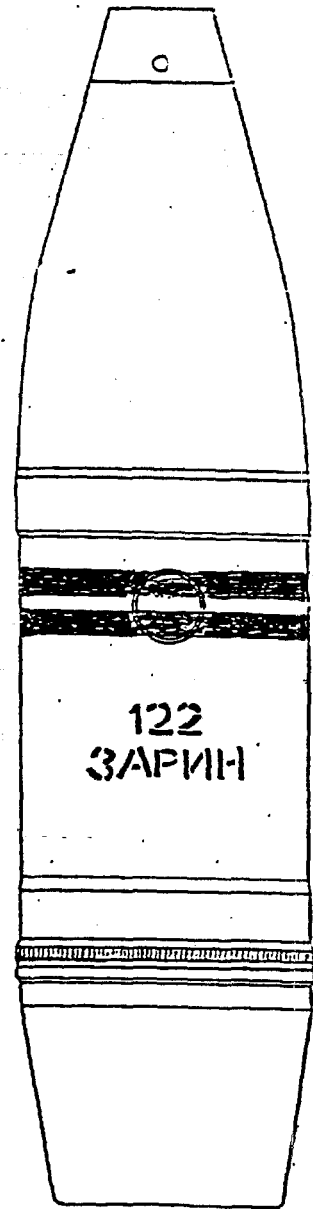

FOREIGN ORDNANCE EOD IDENTIFICATION GUIDE

PROJECTILE, 122MM, CHEMICAL, (PERSISTANT), MODEL UNKNOWN (USSR)

LENGTH EST: 498mm (19.61 in.)  
DIAMETER: 122mm (4.80 in.)  
LOADED WT: 23.10 kg (50.93 lb)  
AGENT/WT: Thickened Lewisite/3.30 kg (7.28 lb)  
FILLER PLUG LOCATION: Base  
BURSTER/CHARGE: Short/TNT  
FUZE: Time, probably the D-1-U or V-90  
SPANNER HOLES: Two in adapter  
SET SCREW HOLES: None  
BASE COLOR: Gray  
BANDS: Green (2)  
MARKINGS: Green

COMMENTS: The projectile externally resembles the Model D-4 122mm smoke projectile. The markings shown are not believed to be the markings used on standard Soviet chemical munitions but are those used for display purposes.

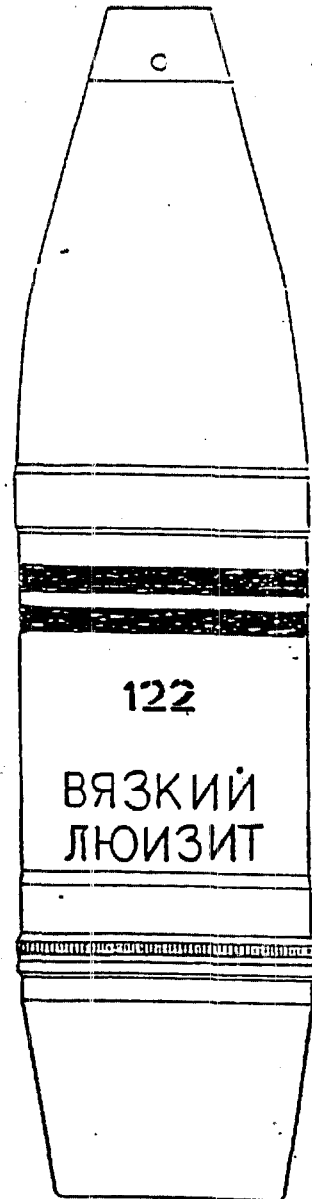

FOREIGN ORDNANCE EOD IDENTIFICATION GUIDE

PROJECTILE, 130MM, CHEMICAL, NON-PERSISTANT, MODEL UNKNOWN (USSR)

LENGTH EST: 601.73mm (23.69 in.)  
 DIAMETER: 130mm (5.12 in.)  
 LOADED WT: 33.40 kg (73.63 lb)  
 AGENT/WT: Sarin /1.60 kg (3.53 lb)  
 FILLER PLUG LOCATION: Side  
 BURSTER/CHARGE: Long/TNT  
 FUZE: PD, probably the V-429  
 SPANNER HOLES: Two in the upper and two in the lower adapter.  
 SET SCREW HOLES: Possibly one in the lower adapter.  
 BASE COLOR: Gray  
 BANDS: Green (2)  
 MARKINGS: Green

COMMENTS: The projectile externally resembles the DTS-1 130mm target marker, smoke projectile. The chemical sheet has a side filler plug, no rear filler plug and a two-piece adapter. The adapter allows the use of a standard fuze as well as a larger diameter fuze which gives greater versatility. The markings shown are not believed to be the markings used on standard Soviet chemical munitions but are those used for display purposes.

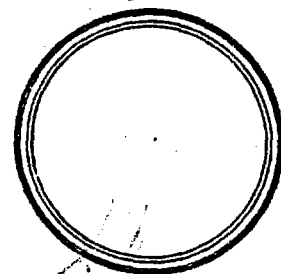
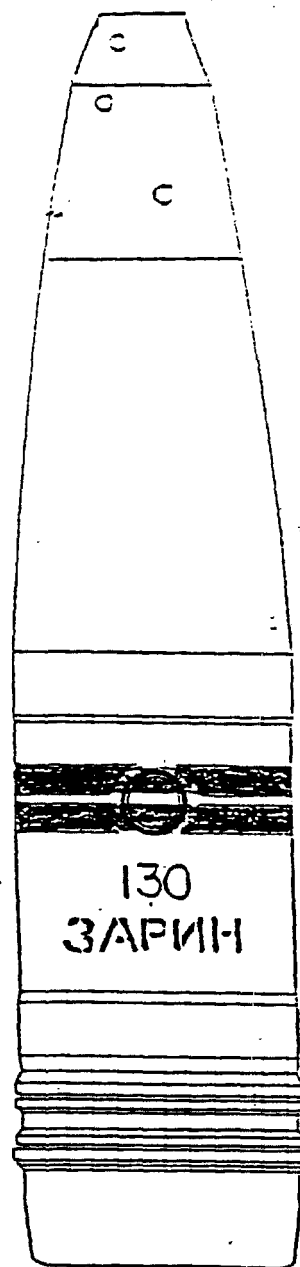

FOREIGN ORDNANCE EOD IDENTIFICATION GUIDE

PROJECTILE, 130MM, CHEMICAL, PERSISTANT, MODEL UNKNOWN (USSR)

LENGTH EST: 601.73mm (23.69 in.)  
 DIAMETER: 130mm (5.12 in.)  
 LOADED WT: 33.40 kg (73.63 lb)  
 AGENT/WT: VX/1.40 kg (3.09 lb)  
 FILLER PLUG LOCATION: Base  
 BURSTER/CHARGE: Short/TNT  
 FUZE: VT, Model Unknown; possible alternate use of the V-90 or the D-1-U  
 SPANNER HOLES: Two in upper and two in the lower adapters.  
 SET SCREW HOLES: Possibly one in the lower adapter.  
 BASE COLOR: Gray  
 BANDS: Green (2)  
 MARKINGS: Green

COMMENTS: The projectile externally resembles the DTS-1 130mm target marker smoke projectile with the exception of the adapter which is of two-piece construction. The two-piece adapter allows the use of a standard fuze as well as a larger diameter fuze giving greater versatility. The markings shown are not believed to be the markings used on standard Soviet chemical munitions but are those used for display purposes.

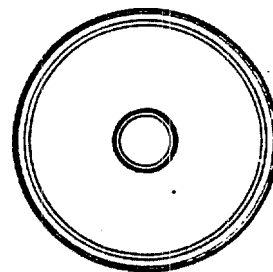
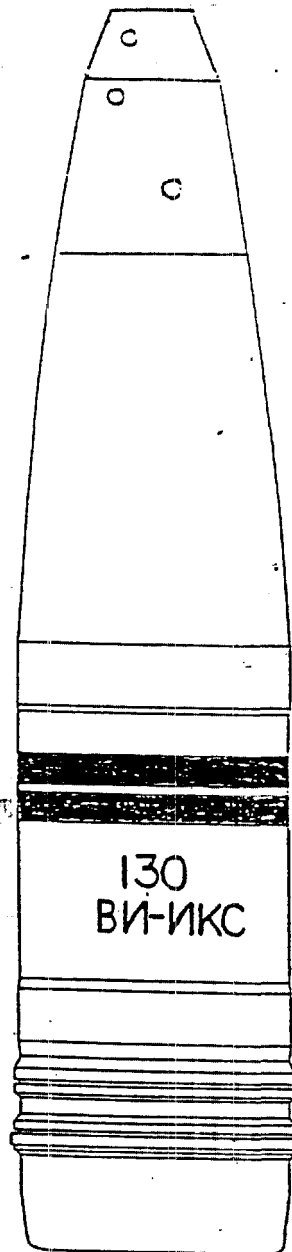

FOREIGN ORDNANCE EOD IDENTIFICATION GUIDE

PROJECTILE, 152MM, CHEMICAL (NON PERSISTANT), MODEL UNKNOWN (USSR)

LENGTH EST: 574.04mm (22.60 in.)  
 DIAMETER: 152mm (5.98 in.)  
 LOADED WT: 40.00 kg (88.18 lb)  
 AGENT/WT: Sarin/2.80 kg (6.17 lb)  
 FILLER PLUG LOCATION: Side  
 BURSTER/CHARGE: Long/TNT  
 FUZE: PD probably the RGM-2 or V-429  
 SCANNER HOLES: Two in adapter  
 SET SCREW HOLES: None  
 BASE COLOR: Gray  
 BANDS: Green (2)  
 MARKINGS: Green

COMMENT: The projectile closely resembles the OF-530 HE projectile which is obsolete. It differs in that the chemical shell has a filler plug in the side and an adapter. The markings shown are not believed to be the markings used on standard Soviet chemical munitions but are those used for display purposes.

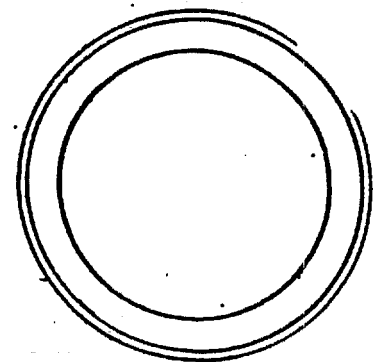
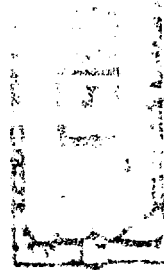
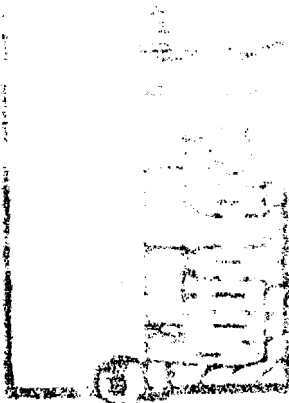
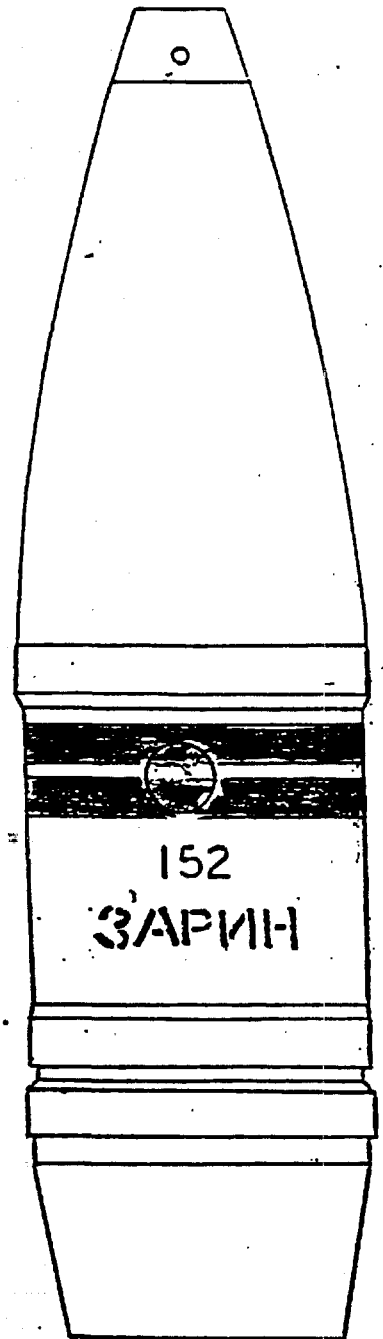

HEAD

FOREIGN ORDNANCE EOD IDENTIFICATION GUIDE

PROJECTILE, 152MM, CHEMICAL (PERSISTANT), MODEL UNKNOWN (USSR)

LENGTH EST: 574.04mm (22.60 in.)  
 DIAMETER: 152mm (5.98 in.)  
 LOADED WT: 42.50 kg (93.70 lb)  
 AGENT/WT: Thickened Lewisite / 5.40 kg  
 (11.90 lb)  
 FILLER PLUG LOCATION: Base  
 BURSTER/CHARGE: Short/TNT  
 FUZE: Time Probably the D-1-U  
 or V-90  
 SCANNER HOLES: Two in Adapter  
 SET SCREW HOLES: None  
 BASE COLOR: Gray  
 BANDS: Green (2)  
 MARKING: Green

COMMENT: The projectile closely resembles the OF-530 HE projectile which is obsolete. It differs in that the chemical shell has a filler plug in the base and has an adapter. The markings shown are not believed to be the markings used on standard Soviet chemical munitions but are those used for display purposes.

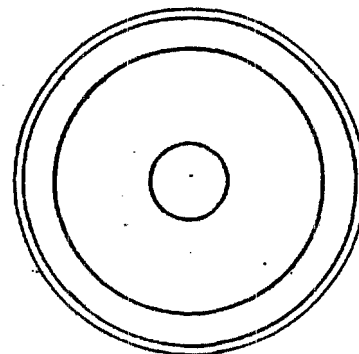
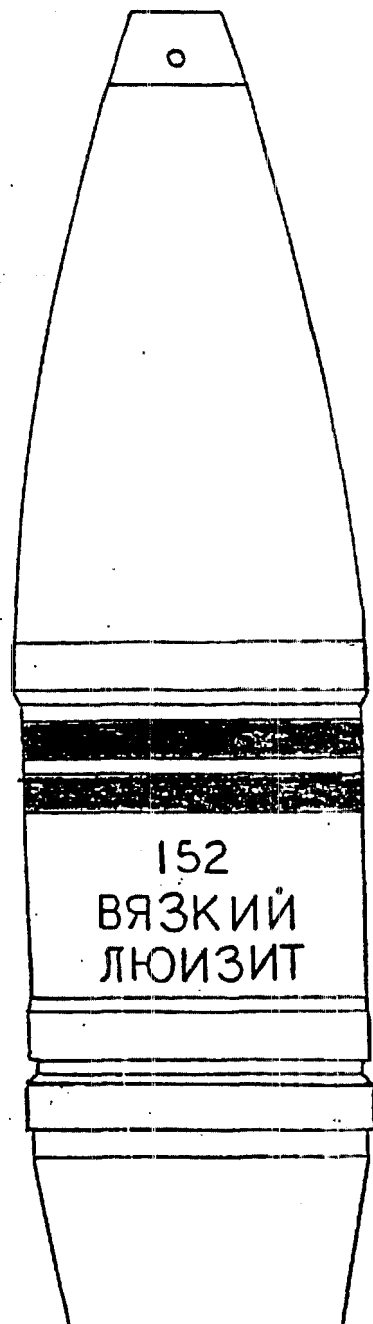

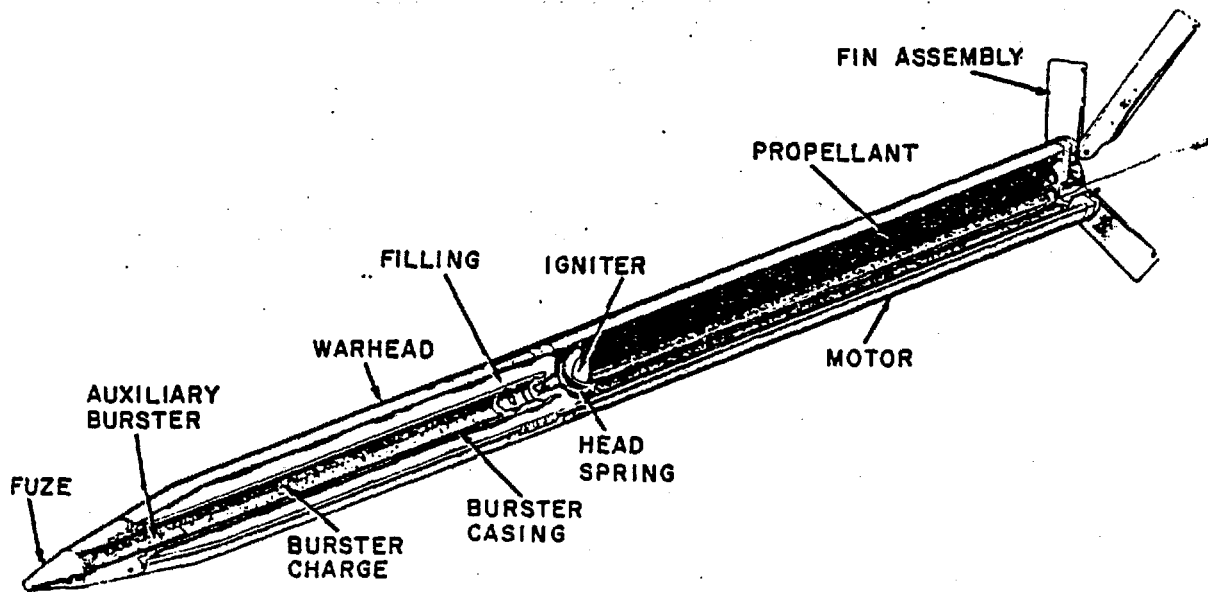

TYPICAL US CHEMICAL ROCKET

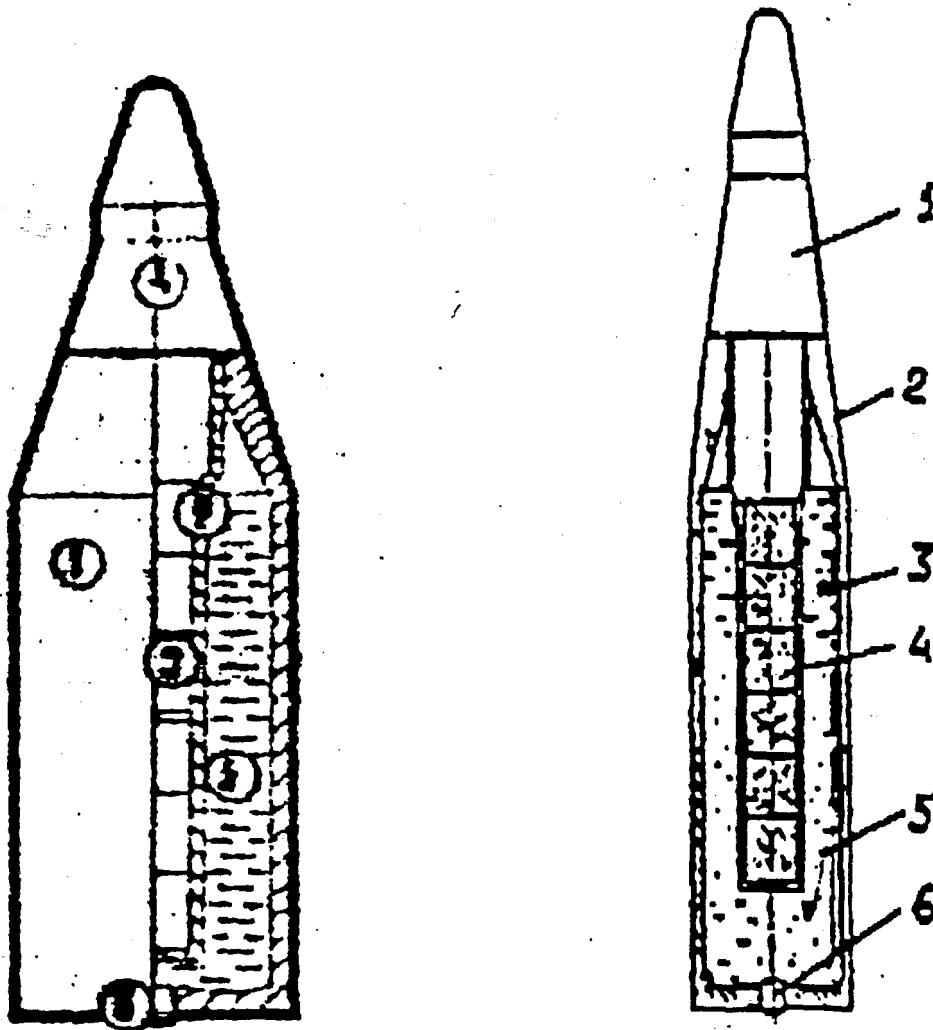

TYPICAL SOVIET CHEMICAL ROCKET WARHEADS

FOREIGN ORDNANCE EOD IDENTIFICATION GUIDE

WARHEAD, ROCKET, 122MM, CHEMICAL, (PERSISTANT), MODEL UNKNOWN (USSR)

LENGTH EST: Overall - 512.83mm (20.19 in.)  
Exposed - 488.95mm (19.25 in.)

DIAMETER: 122.00mm (4.80 in.)

LOADED WT: 19.30 kg (42.55 lb)

AGENT/WT: VX / 2.90 kg (6.39 lb)

FILLER PLUG LOCATION: Base (reported) - side (actual)

BURSTER/CHARGE: Short / TNT

FUZE: Proximity

SPANNER HOLES: None

SET SCREW HOLES: None

BASE COLOR: Gray

BANDS: Green (2)

MARKINGS: Green

COMMENTS: The warhead is shorter than the conventional HE warhead. It has what appears to be a welded adapter at the forward end. The base threads into the rocket motor or into a rocket motor adapter rather than onto the rocket motor as with the normal HE round. The markings shown are not believed to be the markings used on standard Soviet chemical munitions but are those used for display purposes.

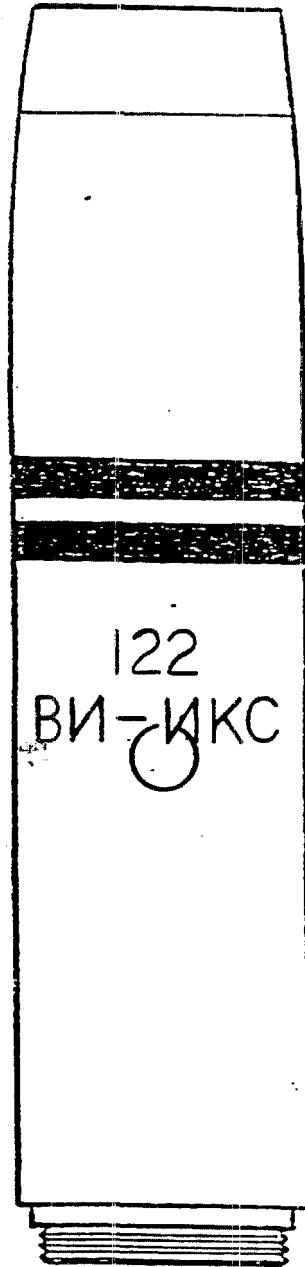

FOREIGN ORDNANCE EOD IDENTIFICATION GUIDE

WARHEAD, ROCKET, 122MM, CHEMICAL, (NON-PERSISTANT), MODEL UNKNOWN (USSR)

LENGTH EST: Overall - 512.83mm (20.19 in.)  
Exposed - 488.95mm (19.25 in.)

DIAMETER: 122.00mm (4.80 in.)

LOADED WT: 19.30 kg (42.55 lb)

AGENT/WT: Sarin / 3.10 kg (6.83 lb)

FILLER PLUG LOCATION: Base (reported)

BURSTER/CHARGE: Long / TNT

FUZE: PD, probably the MRV-U

SPANNER HOLES: None

SET SCREW HOLES: None

BASE COLOR: Gray

BANDS: Green (2)

MARKINGS: Green

COMMENTS: The warhead is shorter than the conventional HE warhead. It has what appears to be a welded adapter at the forward end. The base threads into the rocket motor or into a rocket motor adapter rather than onto the motor as with the normal HE round. Drawing shows the filler plug to be located in the side but this cannot be confirmed by actual pictures. The markings shown are not believed to be the markings used on standard Soviet chemical munitions but are those used for display purposes.

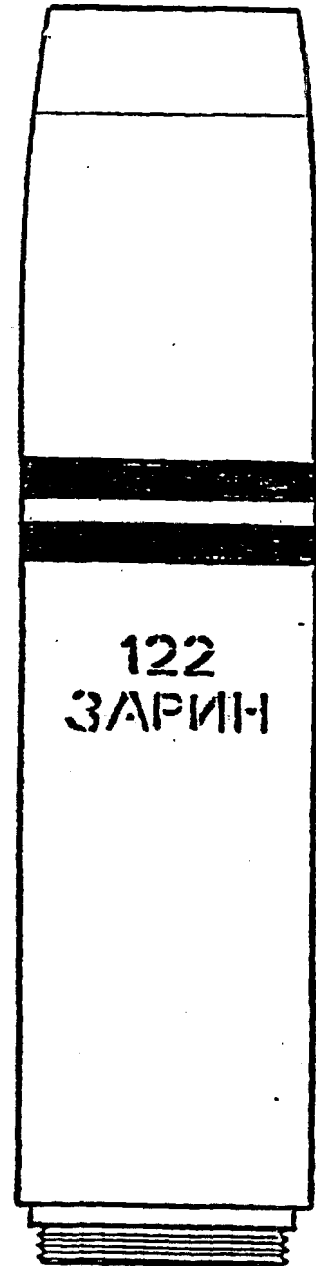

FOREIGN ORDNANCE EOD IDENTIFICATION GUIDE

WARHEAD, ROCKET, 140MM, CHEMICAL, (NON-PERSISTANT), MODEL UNKNOWN (USSR)

LENGTH EST: 410.21mm (16.15 in.)  
 DIAMETER EST: 140.00mm (5.51 in.)  
 LOADED WT: 18.30 kg (40.34 lb)  
 AGENT/WT: Sarin/2.20 kg (4.85 lb)  
 FILLER PLUG LOCATION: Side  
 BURSTER/CHARGE: Unknown/TNT  
 FUZE: PD, probably the V-24 or V-25  
 SPANNER HOLES: Two in adapter and two at the rear of the body  
 SET SCREW HOLES: Two in adapter  
 BASE COLOR: Gray  
 BANDS: Green (2)  
 MARKINGS: Green

COMMENT: The chemical warhead has several differences when compared to the OF-949 HE warhead. It has an adapter, straight sides which do not flare outward at the rear, and a side filler plug. It does not have a two-piece rear body. The adapter threads onto a warhead body rather than into it which may indicate a burster which is larger than the fuze well diameter or a two-piece burster. The filler plug is located just above the junction of the warhead and rocket motor and has a broad wrench slot. The markings shown are not believed to be the markings used on standard Soviet chemical munitions but are those used for display purposes.

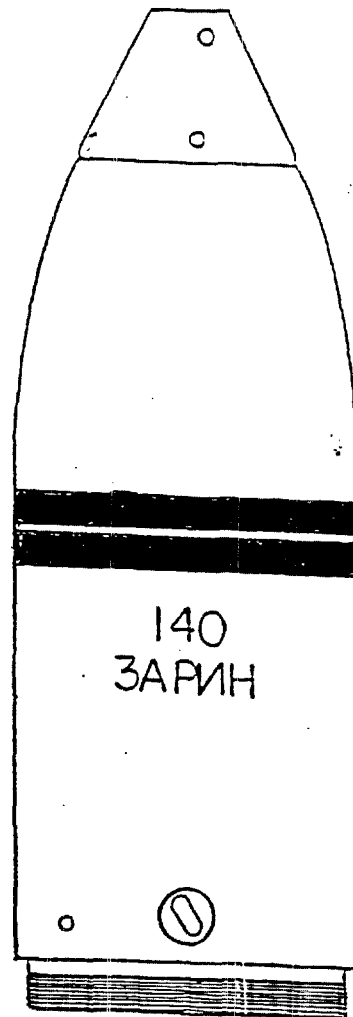

122MM ROCKET WARHEAD

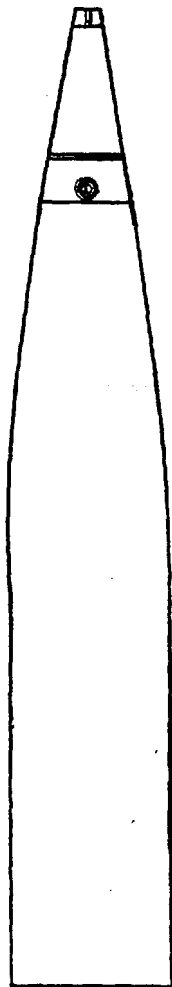

CONVENTIONAL

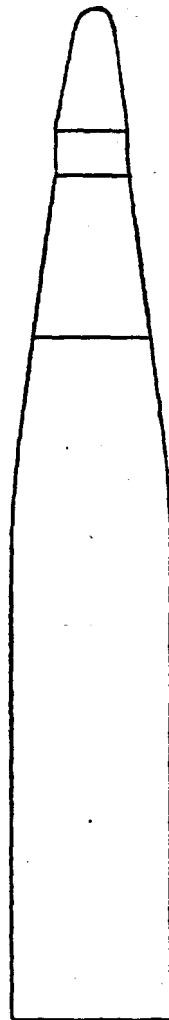

CHEMICAL

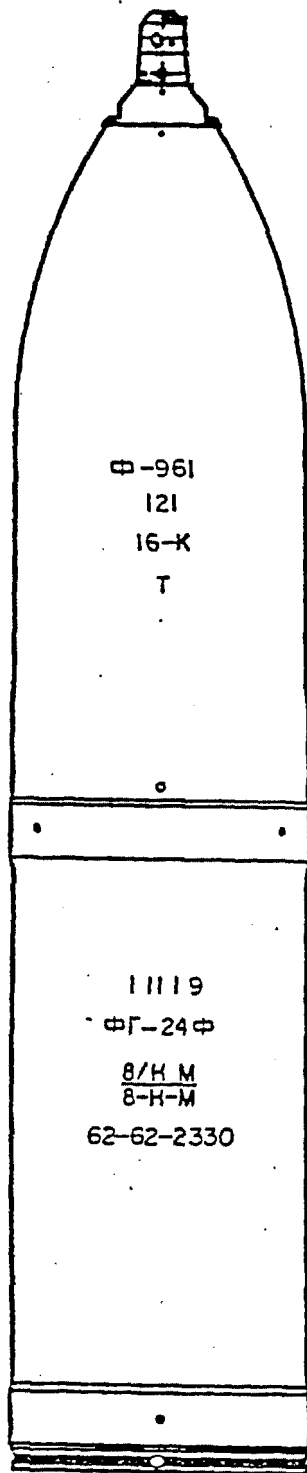

240-MM HE Rocket,  
Model F-961

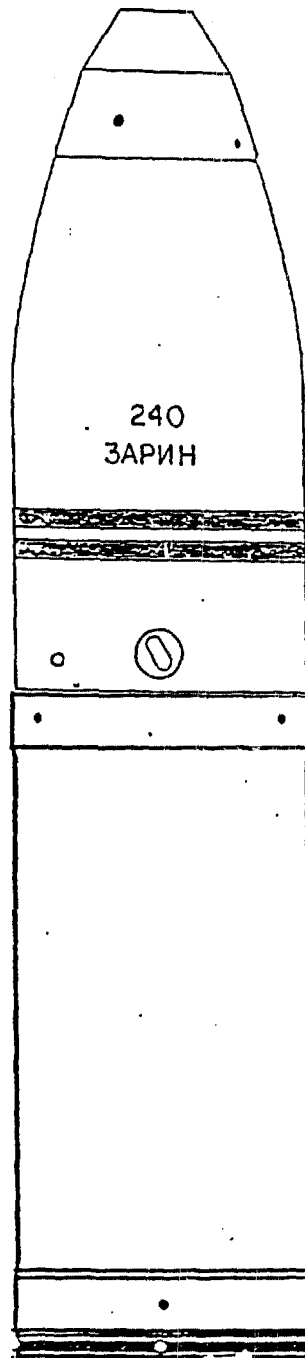

240-MM Chemical Rocket,  
Model Unknown

WARHEAD, ROCKET, 240MM, CHEMICAL, (NON-PERSISTANT), MODEL UNKNOWN (USSR)

LENGTH EST: 588.77mm (23.18 in.)  
DIAMETER: 240mm (9.45 in.)  
LOADED WT: 44.30 kg (97.66 lb)  
AGENT/WT: Sarin/8.00 kg (17.64 lb)  
FILLER PLUG LOCATION: Side  
BURSTER/CHARGE: Unknown/TNT  
FUZE: PD, probably the V-24  
SCANNER HOLES: Two in adapter and two in lower portion of body  
SET SCREW HOLES: One in adapter  
BASE COLOR: Gray  
BANDS: Green (2)  
MARKINGS: Green

COMMENT: The chemical warhead has several differences when compared to the F-961 HE warhead. It has a much larger adapter and is more tapered at the forward end. It has a side filler plug which is located just above the junction of the warhead and rocket motor. The adapter threads onto the warhead rather than into it which may well indicate a burster which is larger than the fuze well. The body does not have a two-piece rear section. The drawings of the warhead show it with a rear fill plug which may indicate another model of the warhead.

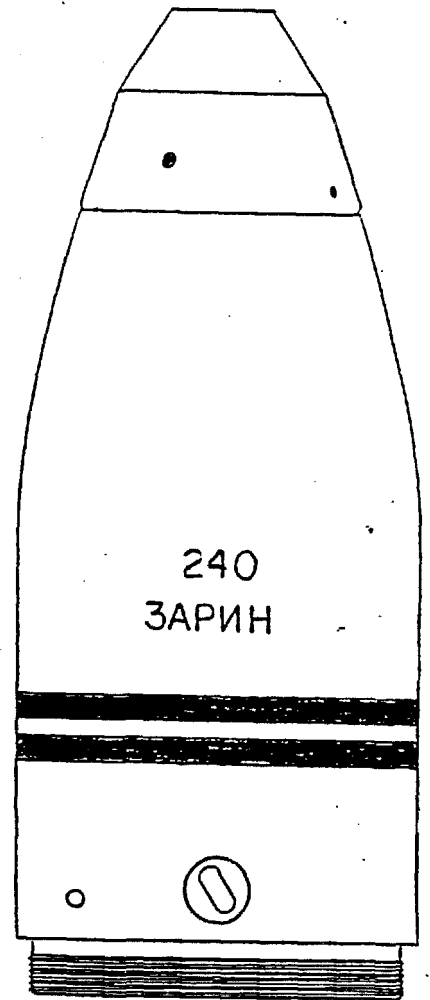

WISDRI 01 01 01

Firing coeff. 19

destruction materials

Bomb, Chemical (Persistent), 100 Kg

1. Shell
2. Primer tube
3. Bursting charge
4. CW agent
5. Filler hole

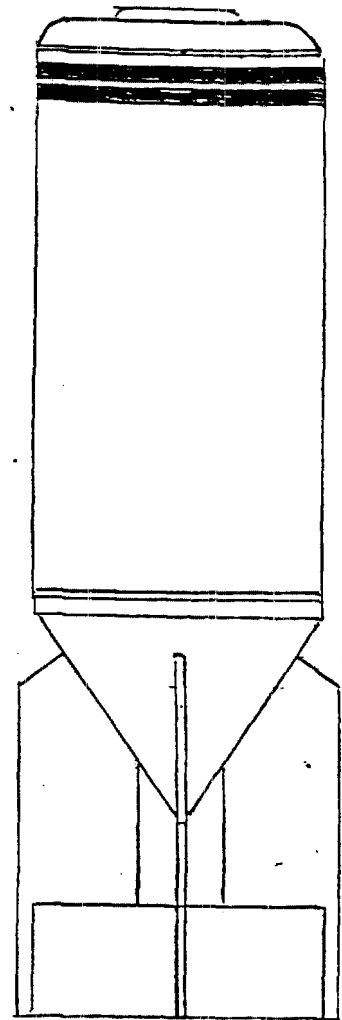
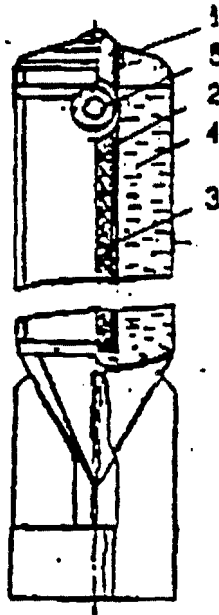

- |                           |                                                                                                                                                            |
|---------------------------|------------------------------------------------------------------------------------------------------------------------------------------------------------|
| 1. Purpose                | To disable personnel through respiratory organs and unprotected parts of the skin, and to contaminate <u>matériel</u> , terrain and engineering structures |
| 2. Calibre                | 100 kg                                                                                                                                                     |
| 3. CW agent               |                                                                                                                                                            |
| Name                      | Mixture of mustard gas and lewisite                                                                                                                        |
| Combat condition          | Vapour, aerosol and droplets                                                                                                                               |
| 4. Method of dispersion   | Explosion of bursting charge                                                                                                                               |
| 5. Fuse type              | Percussion                                                                                                                                                 |
| 6. Weight of bomb         | 80 kg                                                                                                                                                      |
| 7. Weight of CW agent     | 28 kg                                                                                                                                                      |
| 8. Filling coefficient    | 0.35                                                                                                                                                       |
| 9. Construction materials | Steel, copper, aluminium                                                                                                                                   |

Bomb, Chemical (Persistent), 100 Kg

1. External casing
2. Shell
3. Propelling charge
4. Primer tube
5. Bursting charge
6. CW agent
7. Filler hole

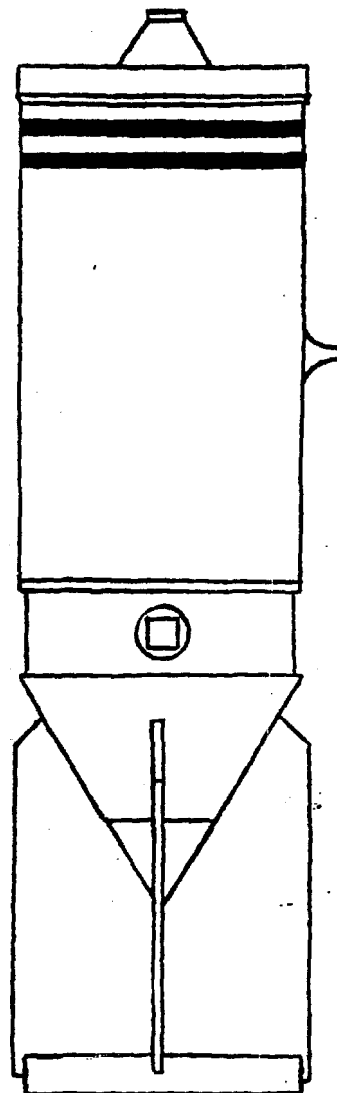
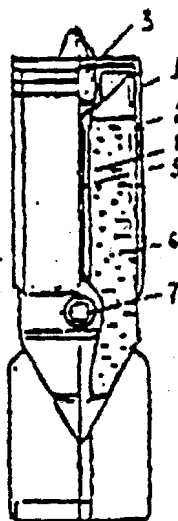

1. Purpose	To disable personnel through respiratory organs and unprotected parts of the skin, and to contaminate <u>material</u> , terrain and engineering structures
2. Calibre	100 kg
3. CW agent	
Name	Mixture of mustard gas and lewisite
Combat condition	Vapour, aerosol and droplets
4. Method of dispersion	Explosion of bursting charge
5. Fuse type	Percussion
6. Weight of bomb	100 kg
7. Weight of CW agent	39 kg
8. Filling coefficient	0.39
9. Construction materials	Steel, copper, aluminium

**Bomb, Chemical (Persistent), 250 Kg**

1. Casing
2. Primer tube
3. Bursting charge
4. CW agent
5. Filler hole

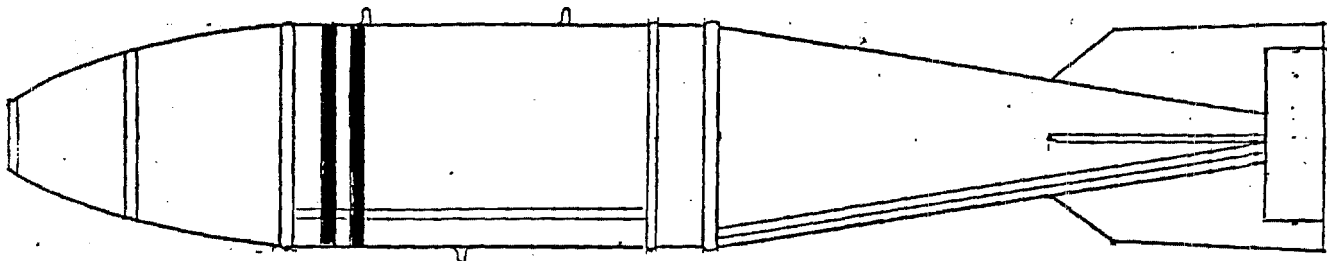
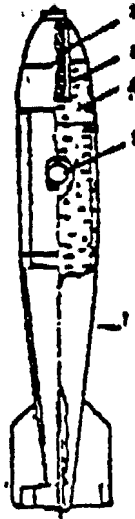

- |                                  |                                                                                                                                     |
|----------------------------------|-------------------------------------------------------------------------------------------------------------------------------------|
| 1. Purpose                       | To disable personnel through unprotected parts of the skin, and to contaminate <u>matériel</u> , terrain and engineering structures |
| 2. Calibre                       | 250 kg                                                                                                                              |
| 3. CW agent                      |                                                                                                                                     |
| Name                             | Viscous soman                                                                                                                       |
| Combat condition                 | Dense aerosol and droplets                                                                                                          |
| 4. Method of CW agent dispersion | Opening of tank by means of bursting charge, fragmentation of CW agent by an inflow of air                                          |
| 5. Fuse type                     | Time                                                                                                                                |
| 6. Weight of tank                | 130 kg                                                                                                                              |
| 7. Weight of CW agent            | 45 kg                                                                                                                               |
| 8. Filling coefficient           | 0.35                                                                                                                                |
| 9. Construction materials        | Steel, copper, aluminium                                                                                                            |

Steel copper aluminium

Bomb, Chemical (Non-persistent), 250 Kg

1. Shell
2. Primer tube
3. Bursting charge
4. CW agent
5. Filler hole

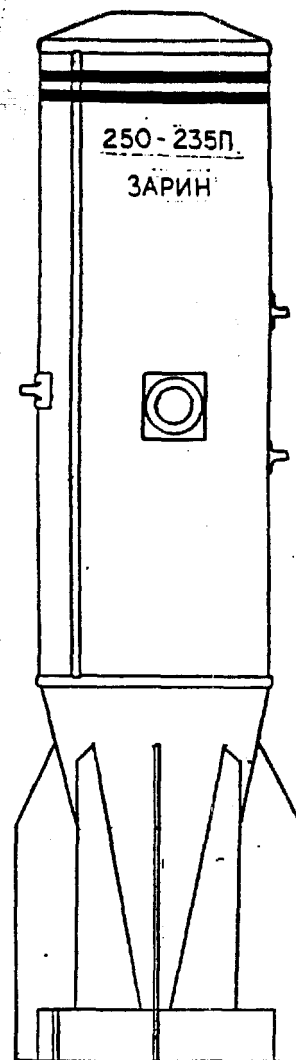
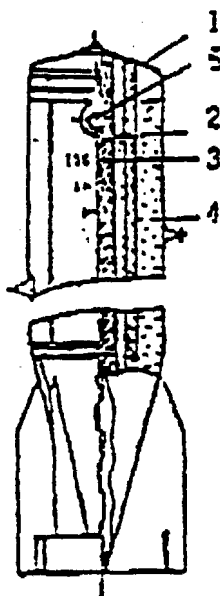

- |                           |                                                 |
|---------------------------|-------------------------------------------------|
| 1. Purpose                | To disable personnel through respiratory organs |
| 2. Calibre                | 250 kg                                          |
| 3. CW agent               |                                                 |
| Name                      | Sarin                                           |
| Combat condition          | Vapour and finely dispersed aerosol             |
| 4. Method of dispersion   | Explosion of bursting charge                    |
| 5. Fuse type              | Instantaneous percussion                        |
| 6. Weight of bomb         | 233 kg                                          |
| 7. Weight of CW agent     | 49 kg                                           |
| 8. Filling coefficient    | 0.21                                            |
| 9. Construction materials | Steel, copper, aluminium                        |
| Construction materials    | Steel, copper, aluminium                        |

Bomb, Chemical (Persistent), 500 Kg

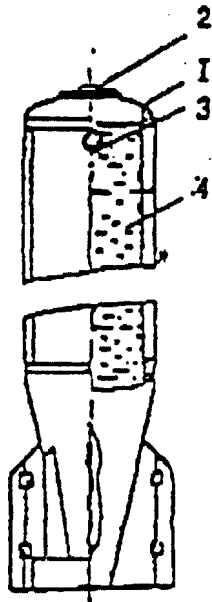
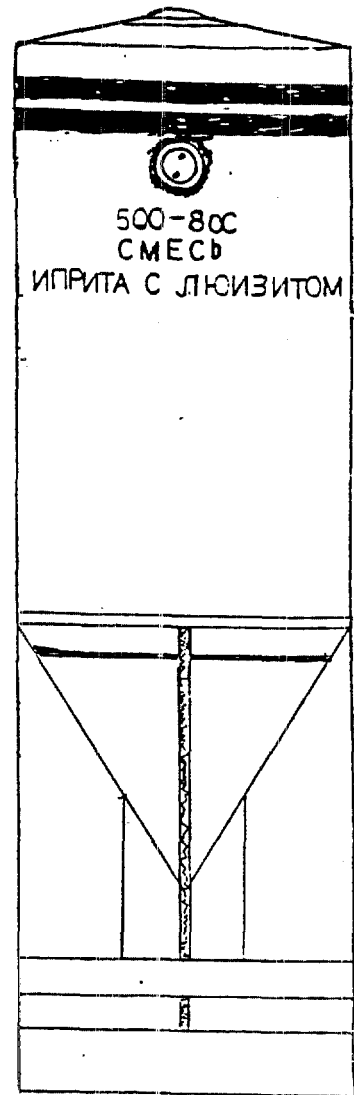

- 1. Casing
- 2. Bursting charge
- 3. Filler hole
- 4. CW agent

Combat characteristics

- 1. Purpose: To disable personnel through respiratory organs and unprotected parts of the skin, and to contaminate matériel, terrain and engineering structures
- 2. Calibre: 500 kg
- 3. CW agent:
  - Name: Mixture of mustard gas and lewisite
  - Combat condition: Vapour, aerosol and droplets
- 4. Method of CW agent dispersion: Opening of tank by means of bursting charge, fragmentation of CW agent by an inflow of air
- 5. Fuse type: Time
- 6. Weight of tank: 280 kg
- 7. Weight of CW agent: 164 kg
- 8. Filling coefficient: 0.59
- 9. Construction materials: Steel, copper, aluminium

Bomb, Chemical (Persistent), 1500 Kg

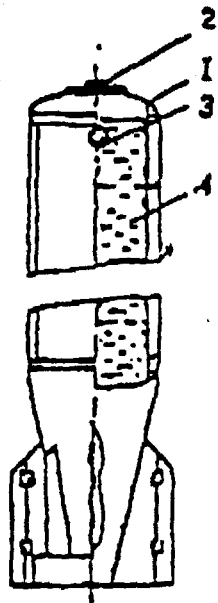

1. Casing
2. Bursting charge
3. Filler hole
4. CW agent

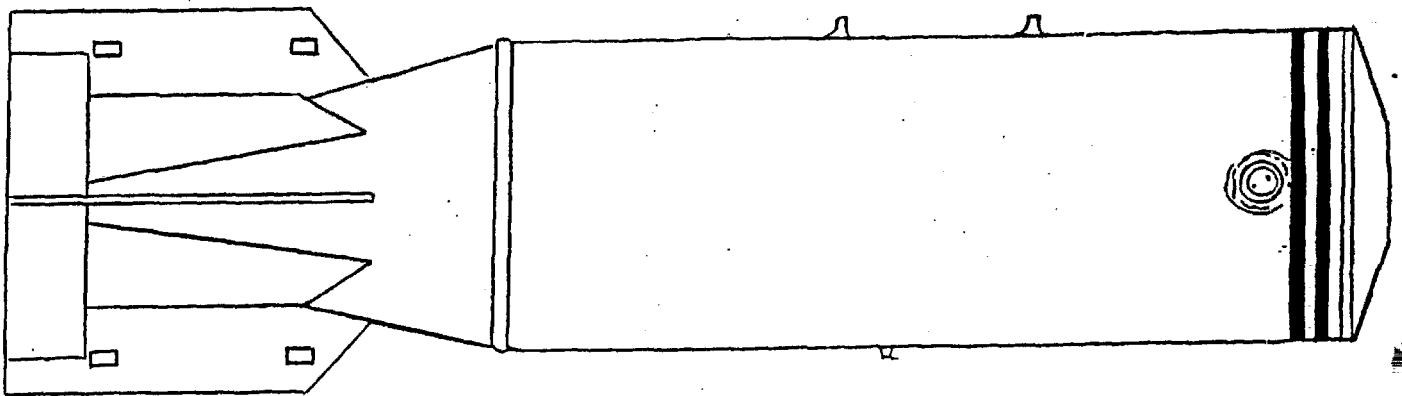

1. Purpose  
To disable personnel through respiratory organs and unprotected parts of the skin, and to contaminate matériel, terrain and engineering structures
2. Calibre  
1500 kg
3. CW agent  
Name: Mixture of mustard gas and lewisite  
Combat condition: Vapour, aerosol and droplets
4. Method of CW agent dispersion  
Opening of tank by means of bursting charge, fragmentation of CW agent by an inflow of air
5. Fuse type  
Time
6. Weight of tank  
963 kg
7. Weight of CW agent  
630 kg
8. Filling coefficient  
0.65
9. Construction materials  
Steel, copper, aluminium