

~~RESTRICTED~~

UNCLASSIFIED

**JSP 333**

*Decl OADR*

# SERVICES TEXTBOOK OF EXPLOSIVES

DISTRIBUTION STATEMENT A  
Approved for Public Release  
Distribution Unlimited

BY COMMAND OF THE DEFENCE COUNCIL

*L. T. Dunnett*

Ministry of Defence  
FOR USE IN THE  
ROYAL NAVY  
ARMY SERVICE  
ROYAL AIR FORCE

Prepared by the Procurement Executive, Ministry of Defence

Issued Mar 72

UNCLASSIFIED  
~~RESTRICTED~~

Prelim  
Page 1

20071109078

**AMENDMENT RECORD SHEET**

To record the incorporation of an Amendment List in this publication, sign against the appropriate A.L. No. and insert the date of incorporation.

A.L. No.	AMENDED BY	DATE
1		
2		
3		
4		
5		
6		
7		
8		
9		
10		
11		
12		
13		
14		
15		
16		
17		
18		
19		
20		
21		
22		
23		
24		
25		
26		
27		
28		
29		
30		
31		
32		
33		

A.L. No.	AMENDED BY	DATE
34		
35		
36		
37		
38		
39		
40		
41		
42		
43		
44		
45		
46		
47		
48		
49		
50		
51		
52		
53		
54		
55		
56		
57		
58		
59		
60		
61		
62		
63		
64		
65		
66		

Services Textbook of Explosives JSP 333

Corrigenda and amendments

Removal and insertion

Remove and destroy page 11 and 12 Chapter 8. Insert new page AL 1, page 11 and 12, Chapter 8.

Handwritten amendments

The more obvious corrigenda and amendments of JSP 333 listed below should be inserted where indicated.

Chapter 1

- para 3, line 9, 'that' should be 'than'
- 15, line 12, 'midly' should be 'mildly'

Chapter 2

- para 10, line 4, '1781' should be '1787'
- 13, line 9, 'Piric' should be 'Picric'
- 15, closing bracket required at end of para.
- 29, line 1, 'Bachman' should be 'Bachmann'
- 75, line 5, 'to us' should read 'to use'

Chapter 4

- para 34, line 3, (3000°C - 4000°K) should be (3000K - 4000K)
- 40, line 13, 'Jouget' should read 'Jouguet' (similarly for footnote page 13 and para.51)
- 42, line 2,  $p_v$  should be  $p^{\circ}, v^{\circ}$
- 65, equation 46, the italic is intended to be the numeral 1

Chapter 5

- para 57, formula for borax should be  $\text{Na}_2\text{B}_4\text{O}_7 \cdot 10\text{H}_2\text{O}$
- 59, line 8 should read  
'fuels - though of lower energy than boranes free from organic groups and still very costly'.

Chapter 6

- para 26, line 6, substitute colon for comma
- 110, figure 27

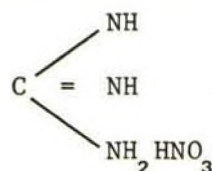

should read

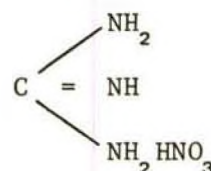

R147862

Chapter 7

- para 21, second sentence should read:  
'It consists of 750 ft (229m) of PVC coated terylene and nylon hose containing a charge of between 3000 lb and 3300 lb (1360 kg and 1496 kg) of an aluminized plastic explosive (para.43)'.  
line 4 should read;  
'..... which are consolidated by a ram operated by compressed air'.

Chapter 8

- para 22, line 8, for attendant~~s~~ read attendant
- 82, line 10, 'polybutadene' should be 'polybutadiene'
- 85, line 8, for '147' read '127'
- 88, for 'nitrogen' read 'dinitrogen'
- 89, line 9, for 'aventitious' read 'adventitious'

Chapter 9

- para 3, second sentence should be  
'Typically the F of I of primary explosives is usually 30 or less, whereas that measured by .....
- 4, Note: A low F of I is not specified for primary explosives, but the F of I is usually low as a consequence of its sensitiveness to friction of heat.
- 21, line 2, 'nitrate' should be 'nitrite'
- 22, for 'F of I of about 15 to 20' read 'F of I of about 30'
- 36, line 3, read '20' for '25'
- 50, line 3, for 'F of I is 8' read 'F of I is less than 10'
- 54, line 4, read 'nitrite' for 'nitrate'
- 54, last line, for 'F of I is 13' read 'F of I is 10'
- 55, penultimate line, for 'F of I is 11' read 'F of I is 10'

Chapter 10

- para 3, line 2 for 'degere' read 'degree'
- 17, line 2, for 'termal' read 'thermal'
- 41, line 3, for 'silicon tetachloride' read 'silicon tetrachloride'
- 60, line 4, for 'termal' read 'thermal'

Chapter 12

- para 10, penultimate line, for 'Noble' read 'Nobel'
- 15, line 3, 'found' should read 'generally found to be .....
- 44, line 3, 'oxamine' should read 'oxamide'

Chapter 13

- para 3, line 3, for 'direct-acton' read 'direct-action'
- 35, line 2, 'rise' should be 'raise'
- 35, line 5, 'Silcone' should be 'Silicone'

Chapter 14

- para.50, line 1 for 'values between 6 and 30' read 'values from <10 to 30'

Chapter 14, Annexe A

- page 20, F of I of 110 for Tetryl column 6 should be 100
- 21, Composition of Torpex 4D column 2 should be 20/55/25

Amendment record sheet

Record the incorporation of this amendment list and insert this instruction before page ii.

35. The waste arising in the Press House (from dough-cutting and from 'heels' left in the cylinders) is reincorporated with a little solvent to compensate for losses, and added to new batches of dough during their incorporation as an aid to the production of homogenous, well-mixed material.
36. When a flashless propellant (known in America as a 'triple base propellant') is being made by this process the appropriate weights of GC/NG paste and picrite are loaded into the empty incorporator together with the acetone/water solvent and incorporated for half an hour before addition of ground carbamite and any other ingredients.
37. Because the weight of cordite for a gun charge is determined by firing proof on a sample taken from a 'lot', 5000 lb to 50 000 lb (2.27 Mg to 22.7 Mg) of propellant, great care is taken at every possible stage in the manufacture to blend the products of batches, and finally, before final inspection, to reblend the lot.

#### *Semi-solvent process*

38. The process described in para. 32 to 37 gives flashless cordites of good density and dimensional regularity only with difficulty, especially in the larger sizes, and to overcome these difficulties another feature of the solventless propellant process was introduced, that is, hot rolling. Cords made as described above are first truck-dried to a solvent content of 4 to 5%, and these cords are then passed through rolls at 35°C to form sheets containing only about 2% solvent, which are then cut into discs to be loaded into the press cylinders, whence the final cords are extruded at a temperature of about 65°C and stove-dried as before. This modified process is known as the 'Semi-solvent Process' and it gives chords of greater flexibility, natural straightness and surface smoothness which can therefore be more readily made up into charges\*.

#### *Picrite-carbamite complex*

39. Brief reference must be made to a problem peculiar to the picrite (flashless) propellants which arose during the Second World War. At one plant it was decided to add the carbamite to the wet mix of GC and NG instead of to the cordite paste in the incorporator; however, this led to higher rates of burning in the final propellant, and this effect was correlated with a lower, and variable, density of the propellant. It was found that in the wet-mixed-paste process there were coarse crystalline agglomerates in the final mix which consisted of an equimolecular compound of picrite and carbamite. This compound, which melts at 90°C, is (unlike carbamite) insoluble in benzene. It is, of course, present in picrite cordites made by the process in which the finely ground carbamite is added to the premixed paste in the incorporator, but it is there in the form of a well-dispersed micro-crystal which does not cause irregular ballistics.

#### *Ballistite*

40. Finally, reference should be made to Ballistite which may be regarded as a special form of 'solvent cordite'. As originally invented by Nobel in 1888 it was intended as a shot-gun propellant, and it is still so used; but it is also employed nowadays in the primary charge for mortars (the secondary charge is usually an NRN powder). The modern composition is:

Nitrocellulose (12.65% N)	60.0	parts	by	weight
Nitroglycerine	38.0	"	"	"
Carbamite	0.5	"	"	"
Potassium Nitrate	1.5	"	"	"
Plus: Chalk	0.15	"	"	"

The NG and NC are wet-mixed and dewatered, but the paste is 'matured' for a week before drying. The dry paste is incorporated with the carbamite, chalk and potassium nitrate (17.5%), in presence of acetone, to yield a dough which is rolled at 55°C to 60°C into a sheet of precise thickness; the sheet, after trimming and maturing overnight, is cut into square flakes from which most of the potassium nitrate is leached out in water, to give porosity. After drying and sieving, the flakes are graphited (0.6%), sifted, blended and lotted; they are 0.06 in (1.52 mm) square and 0.008 in (0.20 mm) thick. Ballistite has a calorimetric value of about 1250 cal/g, and is too hot (and therefore erosive) for use in guns (cf the calorific values of cordites in Table 1).

#### **Solventless cordites**

##### *Manufacture*

41. The process by which the solventless cordites are made is basically that employed by Nobel in 1888 to make his Ballistite (see Chapter 2 — Note: the modern ballistite is made using a solvent, which is

\*Cordites made by the semi-solvent process are characterized by the prefix M: thus cordite MNL.F/2P (560 cal/g) is made by the semi-solvent process, contains picrite (N), is cool (L) and flashless (F) by reason of the presence of 2% potassium sulphate (2P); cordite MNQF is hotter (880 cal/g) than MNF (755 cal/g).

removed on hot rolls), and presumably it was only doubt about the safety of applying it to the manufacture of cordite which hindered its earlier adoption. It was developed in the British Service for Naval cordites, SC and HSC, based on wood nitrocellulose of 12.2% N. A 10% suspension of NC in water is pumped through a tundish into which the requisite amount of nitroglycerine is sprayed (see also para. 46 where the tundish method has been superseded). A tundish is a 3-turn spiral open channel, and is made by welding onto a flat circular plate a 3-turn spiral of strip with a 3 to 4 inch spacing between turns. The NC slurry enters the circular central 'compartment', and the NG is added in the second turn. The mixed slurry leaves the third turn to enter a stirred mixing vessel where carbamite, chalk and candelilla wax (to effect more easy and regular extrusion from the press die) are added; the operation of filling the vessel takes upwards of 12 minutes during 10 of which the NG is fed to the tundish. Vigorous stirring is maintained for half an hour, after which the slurry is fed to the papering machine (see para. 32) to remove the water and form a sheet about half an inch thick.

42. The crumbly, oatmeal-like cake from the machine is dried for 20 hours on aluminium trays in stoving trucks in a current of air at 45°C, after which it is passed through a pair of even-speed rollers at 55°C; in the course of five passages through these rollers the sheet is further dried and is gelatinized, that is, the fibrous structure of the NC disappears as the NC is swelled by the NG and carbamite, even though as much as 49.5% NC is used in cordite SC. If gun cordites are to be made it is usual to cut the sheets from the rolls into discs to load into the press, but if large-size cordites are required it is customary to roll the sheets (cut into strips 6 to 10 in wide) into 'carpet rolls' and load them into the press in this form.

43. Because the gelatinized composition behaves as a true thermoplastic (that is, it softens on heating and hardens on subsequent cooling) it is convenient to press it at a temperature of 45°C to 70°C, see Fig. 3 and 4, using an extrusion pressure of about 4000 lb/in<sup>2</sup> (17.8 MN/m<sup>2</sup>) to 7000 lb/in<sup>2</sup> (31.1 MN/m<sup>2</sup>) (cf the 600 lb/in<sup>2</sup>, 2.7 MN/m<sup>2</sup>, which may be adequate for a non-picric-solvent cordite); before pressing begins the press cylinder is evacuated to remove air which might otherwise appear as inclusions in the cordite.



Fig. 3 Heating carpet rolls (by dielectric means)

44. The processes of rolling and pressing are attended with some fire risk. As the rolls must be attended by an operative, devices have been introduced by which he can feed the sheet to the rolls by remote handling. Above the rolls an electro-optical system functions at the first sign of fire to operate a drencher. The press is situated in a concrete cell surrounded by a mound and operated by remote control. The progress of the operation may be watched by closed-circuit television'.

PREFACE

LIST OF CHAPTERS

## Preface

It is intended that this Textbook should be of use to new entrants into the field of Service explosives in the spheres of research, design, development, production and inspection, and to members of the Armed Forces and Government Establishments who need an introduction to the general subject. Its aim is to give a broad view of the chemistry and properties of those substances of an initiatory, ignitory, explosive, pyrotechnic or propellant character, which are of interest to the British Services at the time (1972) of writing.

Weapons, ammunition and ballistics are touched on only in order to illustrate the requirements which must be met by various types of explosives and some of the problems which can arise in design and development.

The Editorial staff of Air Technical Publications, Procurement Executive, Ministry of Defence, wish to acknowledge the assistance given by many people in the preparation of the Textbook. In particular, thanks are given to Mr A Brewin who drafted the manuscript and patiently answered questions.

Many organizations gave their advice freely during the editing and particular mention is made of: DERDE, DARDE, ROF Bishopton, D Eng Pol (RAF), RAFC Cranwell, RMCS Shrivenham, RNC Greenwich, DGW(N), Home Office, Ordnance Board, D Safety, Safety Services Organisation, DQA (Materials), DWQA(N), Nobel's Explosives Co. Ltd.

# Services Textbook of Explosives

## List of Chapters

	<i>Chapter</i>
<b>Preface</b>	
<b>Introduction</b> .....	1
<b>The historical development of military explosives</b> .....	2
<b>Classification of explosives</b> .....	3
<b>Theory of detonation and properties of explosives</b> .....	4
<b>The manufacture and properties of inorganic compounds used in the explosives industry</b> .....	5
<b>Manufacture and properties of organic compounds used in the explosives industry</b> .....	6
<b>Explosives and explosive compositions and their use</b> .....	7
<b>Propellants</b> .....	8
<b>Primary explosives, sensitisers, cap igniter and detonator compositions</b> .....	9
<b>Pyrotechnic compositions</b> .....	10
<b>Non-metallic materials</b> .....	11
<b>Propellant charges</b> .....	12
<b>Explosive munitions</b> .....	13
<b>Safety and safety tests</b> .....	14
<b>Quality control, environmental effects and compatibility</b> .....	15
<b>Glossary</b> .....	
<b>Bibliography</b> .....	
<b>Index</b> .....	

## CHAPTER 1

## Introduction

## Contents

	<i>Para</i>
<b>The phenomenon of explosion</b> .....	1
<b>The nature of explosives</b> .....	2
<b>Types of explosives</b> .....	5
<i>'High' and 'low' explosives</i> .....	5
<i>High explosives and their detonation</i> .....	6
<i>Primary explosives</i> .....	8
<i>Development from explosive to propellant</i> .....	9
<i>Pyrotechnics</i> .....	12
<b>Principal considerations in choice of military explosive compositions</b> .....	13

## CHAPTER 1

### Introduction

#### The phenomenon of explosion

1. An explosion is a violent expansion, usually of gaseous matter; the energy of expansion appears primarily in the form of heat and light. Some explosions are the consequence of the failure of a pressurized vessel such as, for example, a steam boiler, but explosions of military and industrial interest are produced by explosives or explosive systems, the latter being mixtures of fuels (hydrogen, coal gas, petroleum vapour, coal dust, flour, charcoal, etc.) and oxidants (air, oxygen, nitrates, chlorates, etc.)

#### The nature of explosives

2. Consideration of gaseous explosive systems in particular makes it apparent that in them explosion is a special form of combustion. The fuel is in intimate contact with oxygen (pure or as a constituent of air), so that when a suitable source of ignition is applied the adjacent fuel burns with extreme rapidity. Because of this rapidity, the heat of combustion developed in the spherical element around the initial point of ignition acts in two ways before it has time to diffuse away:

- (1) it imparts ignition energy to the adjacent spherical zone
- (2) it expands the gaseous products of combustion.

These effects proceed with such rapidity that a shock wave is produced in the system, and it was the study of such shock phenomenon which led to current theories of detonation (Chapter 4).

3. Such gaseous systems are of only limited military interest (Chapter 7). The explosives of prime concern in the military sphere are usually solids (for example, gunpowder, TNT) or liquids (for example, nitroglycerine), but the basis of their functioning remains the same, namely that in them fuels are in intimate contact with oxidants. In gunpowder, for example, the fuels (charcoal and sulphur) are in close physical contact with an oxidizing salt (saltpetre); in an explosive chemical compound, such as TNT or nitroglycerine, the fuels (carbon and hydrogen) are present with oxygen in the characteristic molecular structure of the compound. Such condensed (that is, non-gaseous) explosives have the characteristic that their combustion to yield gaseous products gives rise to a much greater relative change in volume of the system that occurs with gaseous mixtures.

4. In consequence of the close proximity of fuel and oxidant in explosives, little stimulus is required to cause them to function. Explosion hazards are latent in them and must be guarded against by constant careful adherence to safety rules — remembering always that 'it is the ultimate purpose of explosives to explode'.

#### Types of explosives

##### *'High' and 'low' explosives*

5. The rates of combustion of explosives may vary greatly, depending not only on their composition or chemical constitution but also on their physical form, their degree of confinement (for example, loose powder, compressed charge, light container, heavy shell) and the nature of the means employed to initiate their combustion. Rates varying from a few centimetres per minute to 8500 metres per second have been measured. Relatively low rates (say, up to 400-500 metres per second) are characteristic of gunpowder and 'smokeless powders', which at one time were known as 'low' explosives in contrast with the more rapidly burning 'high' explosives. (The expression 'low explosive' is not now favoured in the British Services.)

##### *High explosives and their detonation*

6. A true explosive is characterized by the fact that in its combustion process an exothermic (that is, heat-liberating) reaction wave passes through it, following and supporting a 'shock front'. This phenomenon is described as 'detonation' and the velocity of the wave is the 'velocity of detonation' in the explosive under the conditions of the system. As has been stated, the rate of combustion of an explosive may depend on a number of factors, but in all instances conditions can be found in which a maximum value of the velocity of detonation can be measured, characteristic of the particular explosive and known as its 'stable velocity of detonation'. But, depending on the design of the explosive system, detonation may occur at a velocity well below the maximum, when it is described as 'low-order detonation', or at a velocity only a little below the maximum, corresponding with 'high-order detonation' — and consequently with a usually more acceptable order of efficiency of the system from the military standpoint.

7. It has been said in para. 6 that detonation involves a shock front passing through the explosive, which it does at the velocity of sound appropriate to the shock-compressed medium, that is, three times and more that of the normal velocity of sound in the explosive. The emergence of this front from the system gives rise to a destructive wave, known as 'blast', in the surrounding atmosphere; this blast includes behind the shock front a high-pressure zone followed by a rarefaction (*cf* Chapter 13). If the shock front emerges into a more or less rigid solid it gives rise to a shattering effect loosely described as 'brisance' (a term the use of which is not recommended).

#### *Primary explosives*

8. It can be seen that the reaction wave in an explosive must build up velocity in a finite time from the moment of the commencement of the combustion process. This time may be relatively long if that process is initiated merely by the application of a source of heat, and with a small charge it might thus happen that high order detonation might never be achieved. But if the act of ignition is accompanied by a high-velocity shock wave, high-order detonation is achieved much more rapidly. This combination of ignition and shock effects is obtained by the use of 'primary' (also known as 'initiator') explosives, among the most important of which are mercury fulminate, lead azide and lead styphnate. Like other explosives, these are metastable chemical systems which readily transform into reaction products with evolution of thermal energy, but their rate of reaction is very high and reaction is readily initiated by heat (usually from an electrically-heated thin wire) or by mechanical shock (for example, a hammer blow or the stab of a pin). Their reaction products often include solid matter (metals and/or their oxides) as well as hot gases.

#### *Development from explosive to propellant*

9. Even when what later became described as gunpowder was the only known explosive composition, the military technicians of the day discovered that it could be used to do work in a more controlled manner than is implied by the word 'explosion'. There is reason to believe that, before gunpowder was known in Europe, the Chinese had discovered how to stem it into bamboo tubes (and, later, paper tubes) closed at one end, and to stem it in such a way as to form lightly compressed blocks having either flat or re-entrant surfaces at the open end, so that when the gunpowder was ignited at those surfaces it burned in a more or less restrained manner to produce gases which vented from the open end and caused the tube to behave as a rudimentary rocket. In Europe it was discovered in the early years of the 14th century that gunpowder could be burned in a sufficiently strong tube, closed at one end, in such a way as to eject a missile from the open end with considerable velocity. In the course of the next two centuries means were discovered to modify gunpowder so as to produce it in grains of varying sizes (and hence of controlled burning surface) which gave a new degree of control over the ballistic performance of cannon. In the early years of the 16th century it was discovered that yet more control could be obtained by 'glazing' the grains with a coating of graphite.

10. Such is, in outline, the development of the first 'propellant' — an explosive substance which (by reason of its chemical composition and its physical structure and shape) can be burnt in a rapid but controlled manner so that its products of combustion can be used to do work in a likewise controlled manner (for example, in rifles, guns, rockets, engine starter cartridges and aircraft seat-ejector systems).

11. The foregoing remarks relate essentially to solid propellants, but reference should also be made to liquid propellants, a development of the last thirty or forty years. These are of two classes, mono-propellants and bipropellants. The former are, generally, individual chemical substances (for example, hydrogen peroxide, isopropyl nitrate; which in particular are acceptable as not being excessively sensitive to friction and impact) which can be made to yield hot gases under controlled conditions. In the second class a fuel (for example, kerosene, hydrazine, liquid hydrogen) is carried separately from an oxidant (for example, hydrogen peroxide, nitric acid/nitrogen tetroxide, liquid oxygen) and the two are brought together as controlled sprays in a combustion chamber; in some instances the two sprays are self-igniting ('hypergolic' systems).

#### *Pyrotechnics*

12. Apart from primary and secondary (or 'high') explosives and the propellants there is another class of explosive substances of military interest to which reference must be made, namely 'pyrotechnics'. These are mixtures of solid fuels (for example, powdered metals, starch, lactose, resins) and solid oxidants (for example, nitrates, chlorates, perchlorates, peroxides), and are generally sensitive to heat and friction, so that they must be handled with great care during manufacture and filling into pyrotechnic stores. The wide range of fuels and oxidants available has resulted in an extensive range of pyrotechnic compositions (*cf* Chapter 10). They are used as sources of intense light (flares, signal rockets) or, sometimes, of smoke; they also find uses in ignition systems for propellants and to some extent in time-delay systems. A particular example of a pyrotechnic composition is 'thermite', a mixture of aluminium powder and ferric oxide which is readily ignited and burns at a very high temperature to yield aluminium oxide and iron; it was first used for welding steel rails before arc and gas processes were available, but its current military value is as an incendiary agent.

**Principal considerations in choice of military explosive compositions**

13. There is an enormous literature of explosive substances, particularly in the realm of patents. Some of these substances have never come into practical use; some have found application in industry, and a relatively small number have been considered of military value. It will therefore be of interest to consider some of the principal considerations which enter into the decision to adopt for military use an explosive or explosive composition.

14. *Availability and cost:* Modern warfare has tended to necessitate the provision of explosive stores in enormous quantity; consequently all the materials used in those stores, including the explosives, must be derived from the cheapest possible raw materials, which must be as readily available as possible and not subject to priority demands from other quarters (for example, for food or clothing). In the past the very nature of explosives called for the use of much labour, particularly in the filling operations. Not only is such labour increasingly costly but, especially in wartime, it is scarce, so that a desirable military explosive must be as simple as possible to make and as amenable as possible to mechanical handling in the filling processes. In modern phraseology, the design of a military store involves 'value engineering', and, if they have any competitors, the explosives to be used in a store are closely scrutinized on grounds of 'cost effectiveness'.

15. *Stability:* Since explosives are metastable chemical systems it is important that natural processes of degradation (as opposed to the rapid explosive processes induced when required) shall be slow, strictly limited and prevented from becoming auto-accelerative, with consequent risk of the store becoming dangerous or even exploding. To this end it is first necessary that explosives shall be as highly purified (particularly from residues of acid) as is consistent with economics. Thereafter they must be stored, whether in bulk or in filled munitions, under conditions which will be as nearly as possible consistent with the avoidance of degradation: containers and ammunition empties must be scrupulously clean, storage temperatures must not be excessive, etc. In general, nitro-compounds (for example, TNT, RDX) have only a slow rate of degradation, but this is less true of nitric esters (for example, nitrocellulose, nitroglycerine) because the degradation of such esters results in the development of acidity which auto-catalyses further degradation. Thus the chemical conditions of storage of nitric ester systems (for example, cordite) should be mildly alkaline; but some nitro-compounds (for example, TNT, tetryl) are not favoured by alkalinity, which leads to the formation of by-products (nitrolic acids), and it is therefore not desirable in general to mix such nitro-compounds with nitric esters in explosive compositions. It is thus important in choosing a military explosive that the processes of its natural degradation shall be well understood and that practicable means of inhibiting them shall have been devised.

16. *Resistance to water:* Apart from the possible effect of massive quantities of water in impairing the ignition of an explosive it must be remembered that water, even in vapour form, may initiate degradative processes. In some instances this effect renders otherwise potentially attractive explosives unusable; thus tetranitrotoluene, which would be more powerful than trinitrotoluene, readily loses its fourth nitro-group in presence of water with development of free (corrosive) acid. Thus it will readily be understood that explosives for military use, together with all other materials which may be employed with them in an explosive munition, should be easily dried and should not be hygroscopic. Because of its cheapness, ammonium nitrate is a desirable ingredient of some explosive compositions, but the problem of its hygroscopicity is so great that such compositions are not now employed in stores filled in peacetime.

17. *Compatibility:* The conditions of para. 15 and 16 are to some extent inter-linked with compatibility, which is the requirement that the explosive should be as non-reactive as possible, both with materials of construction of munition stores and with other explosives with which it might be in contact or in proximity in such stores. There is of course a corollary to this which is that once an explosive has been accepted into Service, any future design of store in which it is desired to use that explosive should not employ new materials of construction — and this includes varnishes, sealing compositions, etc. — the compatibility of which has not been authoritatively established: this is particularly important now that industry is producing so many potentially useful new materials. Many instances will be found in subsequent Chapters of important problems of compatibility.

18. *Toxicity:* Many explosives, because of their chemical structure, are in some degree toxic; the effects may vary from headaches to dermatitis or to damage to internal membranes. These effects must be carefully studied before an explosive can be considered for acceptance into Service, and must obviously be as minimal as may be, even though the hazards can often be much reduced by careful design of the plant in which the explosive is processed.

19. *Density:* It is often necessary for reasons of the efficiency of an explosive store that the highest possible density of filling shall be achieved. If only because of the problems of handling and transporting large quantities of munitions on active service, there is also a pressure to ensure that such munitions are no larger than is required to produce the desired effects; thus the greatest possible economy is called for in the space available in a store for the explosive, and this implies that a desirable characteristic of an explosive is a good loading density.

## RESTRICTED

**20. Sensitiveness:** All explosives are sensitive in some degree to the effects of mechanical shock, friction, heat, etc., and the degree of sensitiveness of each explosive must be fully assessed and judged in relation to what is already known of the properties of other explosives in its class (HE, propellant, initiator, pyrotechnic).

**21. Volatility and melting point:** It is undesirable that an explosive should be volatile or that it should contain volatile substances. If the explosive is itself volatile it may 'distil' and recondense in undesirable places, and this has been a problem with even such a substance as nitroglycerine, the vapour pressure of which at 20°C is only about 0.0005 mmHg (that of water at the same temperature is 17.5 mmHg), but which has been known to volatilize from cordite in ammunition. On the other hand, some 'smokeless powders' contain traces of residual solvent (usually ether/alcohol) which may emerge on storage with consequent change in the ballistic properties of the powder or development of pressure in filled ammunition. Besides this consideration it is also necessary that high explosives shall not have melting points so low that when the filled weapon is stored in a hot climate 'exudation' takes place, since this may render the store dangerous to handle or to use. At the same time it is often convenient, from the standpoint of filling operations, if the explosive can be melted in a vessel heated by low-pressure steam.

## CHAPTER 2

## The Historical Development of Military Explosives

## CONTENTS

	<i>Para</i>
<b>Early incendiaries</b> .....	1
<b>Saltpetre (Potassium nitrate)</b> .....	2
<b>Gunpowder</b> .....	4
<i>Early development</i> .....	4
<i>Development in Europe</i> .....	6
<i>Changes in gunpowder composition</i> .....	9
<b>High Explosives</b> .....	12
<i>Picric acid (2:4:6-Trinitrophenol)</i> .....	13
<i>Tetryl (2:4:6-Trinitrophenylmethylnitramine)</i> .....	16
<i>TNT (2:4:6-Trinitrotoluene)</i> .....	17
<i>RDX (Cyclotrimethylenetrinitramine)</i> .....	20
<i>HMX (Cyclotetramethylenetetranitramine)</i> .....	27
<i>PETN (Pentaerythritol Tetranitrate)</i> .....	30
<i>Nitrocellulose and Nitroglycerine</i> .....	33
<b>Modern propellants</b> .....	46
<i>Solvent cordite</i> .....	46
<i>Solventless cordite</i> .....	50
<i>Single-base powders</i> .....	53
<i>Composite propellants</i> .....	60
<i>Cast-double-base propellants (CDB)</i> .....	65
<i>Composite-modified cast-double-base propellant (CMCDB)</i> .....	68
<b>Ignition and initiation</b> .....	69
<b>Pyrotechnics</b> .....	77
<i>Development</i> .....	77
<i>'Unguided weapons'</i> .....	79

## CHAPTER 2

## The Historical Development of Military Explosives

**Early incendiaries**

1. In quite early times the desire to attack the enemy from a distance led to the development of the sling and in due course the ballista, which was soon used to hurl masses of burning matter, particularly into besieged towns. There is an extensive literature on early incendiary systems, but it is not relevant to present considerations except that we may here note an erroneous impression (still fairly common) that saltpetre was an ingredient of so-called 'Greek Fire' which, in fact, was developed by the Byzantines of Constantinople in the later years of the 7th century AD. The early literature on Greek Fire shows that the substance was a petroleum distillate thickened by dissolving in it resinous and other combustible matter, but there is no reference to the use of anything resembling saltpetre, which was not known in purified form in the West until about 1225 AD.

**Saltpetre (Potassium nitrate)**

2. There has been a good deal of confusion in the literature relating to the early history of 'nitre', or saltpetre, arising from the early cross-translation into Greek (as 'nitron') and Latin (as 'nitrum') of a Hebrew word 'neter' which, in fact, meant 'soda'. But the earliest records of a substance having properties resembling those of saltpetre occur in the late 12th and early 13th centuries AD, when some Arab authors say that certain efflorescences found on the surface of the ground or on some stones resembled 'Chinese snow'. The efflorescences (like Chinese snow) deflagrated when put on a fire and strongly cooled water when dissolved in it. It seems then, that the Arabs had received some form of saltpetre from China, and information about it diffused into Western countries, where deposits of crude material were found. This, however, was much contaminated with deliquescent calcium salts, and could not have been used in any form of gunpowder until it had been refined by recrystallisation. Crude Chinese and Indian material was richer in true saltpetre than the European, but still needed recrystallisation. In about 1250 Roger Bacon described the purification of saltpetre by recrystallisation, and about 1280 an Arab, Hasan-al-Rammah, described the use of wood ashes in this process, whereby, by double-decomposition of calcium nitrate present in the crude salt, a greater yield of true saltpetre would result.

3. By the late 14th and early 15th centuries there was a fairly extensive saltpetre industry in Europe. But it may be noted, in passing, that it is not until the 16th century that there are references to the use of saltpetre to 'fortify' purely incendiary compositions, although Roger Bacon had described the possibility of composing 'artificially a burning fire, namely from saltpetre and other things . . . '.

**Gunpowder***Early development*

4. Since the Chinese knew of saltpetre by the 10th century AD, as appears from modern researches into their literature, and since they had natural deposits of sulphur, it is not difficult to accept that they developed the earliest forms of gunpowder. The Sinologists have worked on a Chinese manuscript, the 'Wu Ching Tsung Yao', which they seem satisfied was completed about 1040 AD and as a result it has lately become possible to ascribe a date to the earliest use of gunpowder. The 'Wu Ching Tsung Yao' is a treatise on military arts and describes, under the generic name 'huo yao', various mixtures of sulphur and saltpetre with resins, charcoal, etc. which were either incendiary or deflagrating (that is, weakly explosive). Sometimes arsenic and other toxic substances were added to the compositions to produce poisonous smokes. From the treatise it appears that by 1000 AD the Chinese had developed some forms of explosive grenade and bomb which were projected by catapults. The gunpowder recipes in the Wu Ching Tsung Yao may be reduced to the following compositions, recalculated on a basis of 40 parts of saltpetre and treating all carbonaceous matter as 'charcoal'.

	Saltpetre	Sulphur	Charcoal
a	40	21	21
b	40	20	56½
c	40	30	65
d	40	30	19½

These are not unlike the 40:30:30: composition given by Roger Bacon (ca. 1250 AD), which was also the 'slow' gunpowder composition used by the French in the 19th century for stores, such as mines, of relatively low brisance.

5. It may be remarked here that, according to present knowledge, the Chinese did not themselves develop faster-burning gunpowders and learned of guns only from the West.

#### *Development in Europe*

6. Arab writers tell us that by the 7th and 8th centuries AD, large Chinese junks were trading into the Persian Gulf, and by the 11th century the Mongols had reached the Near East, and as a consequence by one or other of these means knowledge of gunpowder spread to the Arabs (whose chemists may have done something to improve the material) although there is no evidence that the Muslims used gunpowder throughout the whole period of the Crusades (1097-1291). It is quite uncertain how and when the knowledge of gunpowder spread further west, or whether the knowledge of it which Albertus Magnus and Roger Bacon had was wholly original or partly acquired. But, although Bacon's (fairly detailed) writings were 'hushed up' by the Church, further progress was made and the discovery of the propellant uses of gunpowder (not appreciated by Bacon) took military art to the point where in 1326 a decree of the Council of Florence provided for the appointment of men to make iron bullets and metal cannon for the defence of the castles and villages of the Republic; Froissart repeatedly mentions the use of guns from 1340. In this country, by 1399 the Crown possessed a number of guns and there was soon some small stock of gunpowder and of saltpetre which, owing to its hygroscopicity, was used in the manufacture of powder only as required.

7. As noted in Chapter 1, the need for control over the ballistic performance of cannon, even when using a gunpowder of optimum composition, led to studies to modify the physical form of the powder. These culminated in the discovery in the 15th century of a process termed 'corning' to produce the powder in granular form so that the burning surface of a propellant charge could be reproducible, and the discovery in the 16th century of the 'moderation' of the surface of the grains by glazing with graphite whereby the first ignition of each grain was less violent and thus less liable to lead to the disruption of the grain.

8. Before leaving the topic of the early development of gunpowder in Europe it may be worthwhile to point out that there is no evidence for the real existence of two characters often credited with writings on that subject, namely, Marcus Greucus (Mark the Greek) and Berthold Schwarz (Black Berthold; Berthold the Monk). The writings attributed to them are now considered to be merely *ad hoc* collections of alchemists' recipes.

#### *Changes in gunpowder composition*

9. It appears from the records that the composition of gunpowders used (but not always manufactured) in England evolved as follows:

<b>Approx Date</b>	<b>1250</b>	<b>1350</b>	<b>1560</b>	<b>1647</b>	<b>1670</b>	<b>1742</b>	<b>1781 on</b>
<b>Saltpetre</b>	<b>40</b>	<b>67</b>	<b>50</b>	<b>67</b>	<b>71.5</b>	<b>75</b>	<b>75</b>
<b>Charcoal</b>	<b>30</b>	<b>22</b>	<b>33</b>	<b>22</b>	<b>14.5</b>	<b>12.5</b>	<b>15</b>
<b>Sulphur</b>	<b>30</b>	<b>11</b>	<b>17</b>	<b>11</b>	<b>14</b>	<b>12.5</b>	<b>10</b>

The more or less progressive enrichment of the content of saltpetre corresponded with increasing availability of this salt and with the use of faster-burning powders which could be moderated by physical means.

10. Until 1760 the manufacture of gunpowder for the British forces remained in private hands, but in that year the Government purchased the powder factory at Faversham. After a disastrous explosion there in 1781 the Government considered giving up the factory, but on the advice of Major Congreve, Deputy Comptroller of the Royal Laboratory at Woolwich, they retained and rebuilt it. In 1781 they bought the powder mills at Waltham Abbey. The improvement in quality of the powder made in these two factories under the supervision of Major Congreve and later his son (who became famous as the Sir William Congreve who developed the military rockets used in the 19th century) enabled the charge weight of powder for naval guns to be reduced from a half to a third of that of the shot. After the Napoleonic Wars the Government retained only the Royal Gunpowder Factory at Waltham Abbey which continued to improve its processes and safety methods and took prizes for its products in the international exhibitions which were held in the 19th century.

11. As the newer explosive substances were developed, the uses of gunpowder declined until it was required only for some pyrotechnics, igniters and delay systems.

#### **High explosives**

12. In the absence of a systematic knowledge of chemistry, and particularly of the chemistry of combustion, it was not likely that a new explosive substance, or class of such substances, would appear with properties superior to those of gunpowder. But the technical development during the 17th and 18th centuries of the discoveries by the alchemists of sulphuric and nitric acids, together with the discovery by the end of the 18th and early in the 19th centuries of their structures and of the reasons for their

properties, opened the way to the production of new explosives by the application of nitric acid or of mixtures of nitric and sulphuric acids to appropriate organic chemicals. An extensive literature on the mechanism and theory of the process of 'nitration' has developed in the last hundred years, but it is not proposed to discuss it in this book; a review will be found in the first volume of Urbanski's 'Chemistry and Technology of Explosives' (Bibliography).

*Picric acid (2:4:6-Trinitrophenol)*

13. Disregarding the chance discovery of picric acid by Glauber in the early 18th century as a consequence of treating such substances as wool and horn with nitric acid (work which was extended to other natural products such as indigo, silk and resins by other workers later in that century) the first coherent study of the nitration of phenol was made by Laurent in 1841. He reacted phenol with nitric acid and was able to isolate dinitrophenol and picric acid, and to determine their constitutions. A further advance was made in 1869 when Schmidt and Glatz found that it was advantageous first to dissolve the phenol in sulphuric acid, thus converting it into phenol-4-sulphonic acid which nitrated more smoothly. In this country Frederick Abel pursued this work from the military standpoint, following the discovery that picric acid could be caused to detonate. He advocated the use of 'Picric Powder' (a mixture of 40% ammonium picrate and 60% potassium nitrate) for filling shells, and the manufacture of picric acid at the Royal Gunpowder Factory was authorized in 1874. However, this mixture was not extensively used at that time, though subsequently it was employed as a 'boosting composition' to assist the detonation of picric acid.

14. In 1885 Turpin took out patents covering the application of picric acid as a filling for shells, and it was adopted under the name Lyddite for the British Service in 1888, remaining in use until the early stages of the First World War. Later, a mixture of picric acid and dinitrophenol was developed under the name Shellite; its explosive properties were similar to those of picric acid, but its melting point was low enough to permit of its use for poured fillings.

15. Because of its acidic nature, the manufacture and use of picric acid called for numerous precautions against the possible formation of sensitive metallic salts. But another problem only became fully manifest in the Boer War, when it was found that the explosive in British picric-filled shell did not detonate completely (probably, as we should now think, because of the inadequacy of design of the exploder ('boost' system) with the consequence that clouds of finely-divided unburnt picric acid were formed when shells exploded, giving rise to accusations of the use of 'poison gas'.

*Tetryl (2:4:6-Trinitrophenylmethylnitramine)*

16. The problem that arose in the Boer War that clouds of unburnt picric acid were formed when shells exploded, together with other armament problems which appeared at the time, contributed to the founding of the Research Department, Woolwich. This Department decided, in the light of the availability in the dyestuffs industry of dimethylaniline and of its ease of nitration to yield tetryl, that tetryl should be the replacement for picric acid wherever such replacement was called for, as it was more readily detonated and had a higher velocity of detonation than picric acid. Tetryl had first been discovered by Mertens in 1877, and by 1910 the Research Department had developed the technology of its manufacture to the point at which the explosive could be approved for Service use; which, however, could not include employment as an improved booster for picric acid because its stability was impaired in presence of the latter. It could not be used alone as a shell filling because it was too sensitive. It was not manufactured on a large scale until the outbreak of the 1914-18 War.

*TNT (2:4:6-Trinitrotoluene)*

17. Discovered in 1863, TNT was first used as a shell filling by the Germans in 1902. In the years immediately following the Boer War some work was done on its application in the British Service even to the extent of trials in three sizes of shell up to 6-inch, but it was discontinued.

18. On the outbreak of the 1914-18 War it was soon discovered that the enemy had found in TNT a reasonably insensitive substitute for picric acid, having a melting point of about 80°C which rendered it useful for poured fillings. Toluene, the raw material for TNT was a by-product of the coal-tar industry and was not readily available from this source in the quantities which it soon appeared would be required; but this country had access to Borneo petroleum of which toluene was a constituent, and thus adequate supplies were assured. (In more recent times the development in the petrochemical industry of processes for the catalytic 'reforming' of hydrocarbons has provided a large source of synthetic toluene.) The nitration process also presented problems because it called for the use of very strong acids, involving the manufacture of oleum (sulphuric acid containing free sulphur trioxide); it also required the use of fairly high temperatures. However, during 1915 a batch process for the manufacture of TNT was developed and a large manufacture was set up. Thus, with TNT and TNT mixtures (for example, with ammonium nitrate) as fillings and with tetryl in pellet form as a booster, satisfactory explosive systems for shells, bombs, mines, grenades, etc., were developed and very large-scale output of munitions was possible. The total production of TNT six months after the outbreak of the War was only 143 tons, but it had reached 238,000 tons by the end of the War in 1918, when a continuous process for the manufacture of TNT was also in operation.

19. Reference has been made to the use of mixtures of TNT with ammonium nitrate; these were known as amatols and were much used for land-service shells and for air-service bombs. However, they tended to be corrosive, and the naval service restricted their use to mines and depth charges. For special limited requirements ammonium nitrate was replaced by barium nitrate, such mixtures being designated baratols.

*RDX (Cyclotrimethylenetrinitramine)*

20. Following on the 1914-18 War it was decided that a search should be made for an explosive more powerful than TNT, but capable of being made in considerable quantity. Obviously, this explosive should have a stability comparable with that of TNT (the stability of which had been found very satisfactory) with which it should desirably be compatible; it should also not be unduly sensitive. After an extensive investigation of substances, which included pentaerythritol tetranitrate (PETN), as well as numerous attempts to synthesize hexanitrobenzene (in the course of which certain high-melting nitroaminobenzenes of current interest were made), the Research Department, Woolwich, concluded that the balance was in favour of RDX on grounds of power, stability, sensitiveness, availability of raw materials and overall economics.

21. The compound had first been made by Henning in 1899, by dissolving hexamine (hexamethylene-tetramine) in concentrated nitric acid and pouring the solution into cold water, whereupon the product appeared as a fine, white, crystalline deposit. (He had thought that it might be useful in the treatment of heart disease.)

22. The development of the manufacture of RDX encountered some difficulties (Chapter 6) which were best solved by the adoption of a continuous nitration and dilution process which yielded the product in a crystalline form readily capable of continuous filtration. By the outbreak of the Second World War in 1939 the process had been factory-proved and plant to produce 150-200 tons per week was built at ROF, Bridgwater, and the Woolwich process was later adopted by the USA.

23. In Canada and America two other processes for the production of RDX were developed during the War; they depended for their viability on the more ready availability of acetic acid and acetic anhydride in those countries than in the United Kingdom.

24. In the period between the First and Second World War both the Americans and the Italians had worked on the nitration of hexamine, but had not developed successful processes. In 1945, however, it was found that the Germans had devised processes very similar to those employed by the British and Americans before and during the 1939-45 War.

25. RDX was found too sensitive to be used alone, or even to be pressed into pellets as tetryl could be. But only small additions of wax or other phlegmatizing agents rendered it usable for the more important fillings, while in admixture with TNT it gave very useful pourable fillings. When milled with certain phlegmatizers on hot rolls it gave a plastic explosive very useful for demolitions.

26. Before leaving the subject for the present, it may be of interest to say something of the reason why this explosive (known in America as Cyclonite, in Germany as Hexogen and in Italy as T.4) is called in this country RDX. At a certain stage in its development it should have received a number in the Research Department list of explosive substances, but as access to the list was temporarily not possible the number 'X' was assigned *pro tem*, and the title RDX was subsequently legitimized for everyday use in the Service in the light of the derivation of the substance from hexamine.

*HMX (Cyclotetramethylenetetranitramine)*

27. It was remarked above that a continuous filter was used in the Woolwich process for RDX. After some time it was noticed that some crystals of an unusual shape had adhered to a surface of this filter. These were removed and on examination were found to have the same elemental composition as RDX but to have a molecular weight one-third greater. The explosive power of the material was the same as that of RDX, but the density was greater. If recrystallized from suitable solvents this material could appear in four crystalline modifications (known as alpha, beta, gamma and delta) of which the beta form was the most stable and the least sensitive. The amount of this material called HMX (High Molecular-weight X) in the RDX from the Woolwich process was of the order of only 0.1%.

28. When in due course the second American process for RDX was developed, it was found that the product contained appreciable amounts of HMX, of the order of 5%. This enabled a more extensive study to be made of its properties, when it was found that the velocity of detonation was higher than that of RDX, and this finding, coupled with the higher density, rendered HMX marginally more desirable than RDX for certain special purposes.

29. Accordingly, investigations were made to find modifications to the so-called Bachman process for manufacturing RDX to ensure that HMX appeared as the major product, and to develop a recrystallization process which would remove RDX and ensure the appearance of the HMX in the beta form, free

from other modifications. In this country this work was brought to a successful conclusion in 1955 in the Explosives Research and Development Establishment, and the processes were then established in the production factory. However, HMX is at least four times as costly as RDX.

*PETN (Pentaerythritol Tetranitrate)*

30. It will be well to say something of the history of PETN since, although it is not made in the ROFs, it is manufactured commercially by Nobel's Explosives Co Ltd and is in Service use. In admixture with TNT and under the name Pentolite it was employed in the early years of the 1939-45 War as the filling in foreign-designed 20 mm ammunition for aircraft cannon.

31. The raw material for PETN is pentaerythritol (PE), which was first prepared by Tollens and Wigand in 1891 by the condensation of acetaldehyde with formaldehyde in alkaline aqueous solution. PE is today an important industrial product, being the basis of synthetic resins. In 1894 the Rheinisch-Westfaelische Sprengstoff A.G. prepared PETN by the nitration of PE.

32. The explosive properties of PETN are very similar to those of RDX but as the substance is a nitric ester it is not quite so inherently stable, and it is rather more sensitive. During the 1939-45 War the Germans, besides using it in admixture with TNT, made wide use of it (dephlegmatized with a mineral wax) as exploder pellets.

*Nitrocellulose and Nitroglycerine*

33. It is now necessary to go back in history to the first half of the 19th century to trace the development of nitrocellulose and nitroglycerine, which became important as basic ingredients of some important Service propellants.

34. *Nitrocellulose*: In 1833 Braconnot reported the production of what he named Xyloidine, by dissolving vegetable matter in nitric acid and pouring the solution into a large volume of water; the precipitated product was a nitrocellulose containing probably only 5 to 6% of nitrogen. In the same year Pelouze subjected paper and cotton to the action of nitric acid, but without dissolving them; he obtained a similar product to that of Braconnot, which he later named Pyroxylin.

35. In 1845 Schoenbein studied the effect on organic substances, including cotton, of mixtures of nitric and sulphuric acids. He thus obtained a highly nitrated cotton, and in 1846 discovered its explosive properties which were also noted independently in that year by Boetger. Schoenbein at once took out patents (for example, Brit. Pat. 11407 in 1846 in the name of John Taylor) and fostered the commercial production of nitrocotton. In this country the process was quickly taken up by John Hall and Sons at Faversham. The process called for the hanks of nitrated cotton to be washed in running cold water before being dried. However, it soon transpired that this product was liable to spontaneous combustion and a disastrous explosion destroyed the Faversham plant completely in 1847, and it was not rebuilt. Other explosions followed in other countries — even at a plant in Austria, established by Lenk von Wolfsburg, where the crude nitrocotton was purified by 14 days' washing in running water followed by a few minutes' boiling in a 2% sodium carbonate solution and storage in a concentrated sodium silicate solution before further washing and drying.

36. Little further progress was made with the development of nitrocotton until, in a series of patents and papers commencing in 1865, Frederick Abel, working in the Royal Laboratory, Woolwich, and in the Royal Gunpowder Factory, Waltham Abbey, showed that the accidents with nitrocotton were due to the incomplete removal of readily decomposable products retained in the capillary fibres of the cotton, and that 'stabilization' could be achieved by prolonged boiling in hard water followed by 'pulping'—chopping finely in water in a paper-mill beater. He also showed that this pulped product if pressed into blocks burned less rapidly, although it was still too 'violent' to use in a gun. Abel's stabilization process was later improved on by Robertson, who reported his work in 1906, and this led to the standard Service process for stabilization of nitrocellulose, still in use with only small modification.

37. Following on Abel's work, commercial production of nitrocotton was reintroduced, at Stowmarket, using his processes, to meet the growing demand for it for blasting and for shot-gun powders, and he introduced the manufacture of nitrocellulose into the Royal Gunpowder Factory in 1872.

38. In 1868 Abel and Brown had discovered that compressed dry guncotton could be detonated by a mercury fulminate detonator, and a little later they found that compressed wet guncotton could be brought to detonation by a small booster of dry guncotton initiated by a detonator. These 'wet guncotton slabs' remained an important Service demolition store until RDX plastic explosive superseded them; they were packed in sealed cans to prevent them drying out. In some countries compressed guncotton was used as a shell filling until it was replaced by picric acid.

39. Meantime, in 1865, Schultze had produced a shot-gun propellant by impregnating a mixture of nitrocellulose and cellulose with barium and potassium nitrates and granulating the material with a small

## RESTRICTED

quantity of paraffin wax as a binder. This process was taken up in this country in 1882 by the Explosives Company, who modified it by adding a mixed solvent (ether/alcohol) which partially gelatinized the nitrocellulose and facilitated the incorporation of the salts. The 'EC' powders so produced burned too rapidly, however, for use in guns having rifled barrels.

40. In a series of papers from 1890, Vieille reported his development of the observation of earlier workers that if nitrocellulose is dissolved in organic solvents and the solution poured onto a surface to give a film on drying, the gelatinized film burned more slowly than the original fibrous nitrocellulose. He worked nitrocellulose with ether/alcohol until the fibrous matter was converted into a pastelike mass and rolled this into sheets which he then cut into small squares before drying. The French army found that these could be used as a propellant in rifled guns, and adopted this form of propellant under the name Poudre B.

41. Throughout the 1914-18 War, cotton remained the raw material for the nitrocellulose required for the British Services, and most of the nitrocellulose was of the 13.1% nitrogen-content type. But it had been difficult to spare from other uses the cotton required, and after that War the Research Department, Woolwich, turned to the problem of substituting it by wood cellulose. Suitable sources of woodpulp were found and their products converted, under careful control, into paper which was then cut into shavings which could be nitrated in the same plant as had been used for cotton; later the same plant was used to nitrate paper in scrolls. For various reasons it was found convenient to nitrate this paper to the 12.2% nitrogen level, and the process was adopted by the Royal Naval Cordite Factory, Holton Heath, to provide the nitrocellulose for a new family of cordites for the Naval Service.

42. *Nitroglycerine*: In 1846 Sobrero added glycerine to a cooled mixture of nitric and sulphuric acids and then poured the mixture into excess water, when an oil separated and settled to the bottom; the weak acid was decanted and the oil repeatedly washed with water. Sobrero soon recognised the explosive properties of this oil, but he did not pursue their development, deeming nitroglycerine too dangerous to render its manufacture and use feasible.

43. However, many others were not deterred by these considerations, and in remote parts of the world nitroglycerine was often made on site by civil engineers building roads and railways and needing to blast rock formations. There were of course many accidents, and the manufacture of nitroglycerine was not rationalized until Nobel took out his series of patents from 1864 to 1866; he too had accidents, but persisted in his work. Having made the nitroglycerine (in the first place essentially by Sobrero's method, but later by modifying the composition and quantity of the nitrating acid so that the oil separated directly without dilution of the acid) his next problem was to transport it safely to its point of use. This he overcame by diluting the explosive with methyl alcohol, which was removed on site by pouring the mixture into water and recovering the oil after decanting off the aqueous layer. This still had the objection that it left the user to handle neat nitroglycerine, and Nobel next turned to his observation that kieselguhr (a diatomaceous earth) would absorb a large quantity of nitroglycerine. In 1867 he patented guhr dynamite, consisting of 75% nitroglycerine and 25% kieselguhr. This explosive rapidly became popular, and Nobel established factories for its production in many countries including Scotland, where he founded at Stevenston, works which ultimately became the basis of what is now known as Nobel's Explosives Company, a subsidiary of Imperial Chemical Industries Ltd.

44. Nobel also noticed that nitroglycerine would dissolve nitrocellulose, and hence he developed Blasting Gelatine and, by incorporating into the latter sodium or ammonium nitrates, the family of Gelignites. These explosives had an important advantage in that the nitroglycerine in them was not displaced by water, as occurs with guhr dynamite. However, one disadvantage remained, namely, that at low temperatures the nitroglycerine would freeze, rendering the explosives more susceptible to shock (see also Chapter 6); in due course this problem was overcome by lowering the freezing point of the nitroglycerine by adding to it nitroglycol, and hence was derived the family of 'Polar' Gelatines and Gelignites. The many other advances made in the sphere of commercial blasting explosives cannot be traced here.

45. Nobel made one more advance, which is of military interest, when in 1888 he mixed nitroglycerine and nitrocellulose under water, dewatered the product by filtration and dried it by repeated passages through heated rolls to give a horny sheet of a thickness suitable for cutting into small squares which constituted a propellant suitable for use in rifled guns. This he named ballistite.

### Modern Propellants

#### *Solvent Cordite*

46. In the light of the adoption by the French of Poudre B and of the development by Nobel of ballistite, the British Government appointed a committee to consider what would be the most suitable propellant to succeed Service gunpowder. The committee was not satisfied with any of the propellants then available, and authorized the Royal Laboratory, Woolwich, to embark on a new search. The work was conducted by Abel, Kellner and Dewar, and they adopted the incorporation of nitrocellulose with

nitroglycerine in presence of a solvent to assist gelatinization of the nitrocellulose, but broke new ground by extruding the solvent-containing dough in cords of controllable diameter and therefore of controllable burning surface. They used the nitrocellulose of 13.1% nitrogen content then being produced at the Royal Gunpowder Factory; this was dried and hand-mixed with the appropriate amount of nitroglycerine after which the mixture was mechanically incorporated with a little mineral jelly in presence of acetone as solvent. After extrusion of the dough so formed into cords, the cords were subjected to prolonged gentle heating to remove the solvent as a result of which they became fairly hard and of a texture not unlike that of ballistite. Patents were taken out in 1889 and manufacture started in the same year at the Royal Gunpowder Factory, the propellant being officially designated cordite. It was approved for Service in 1891, and by 1896 its proof and inspection was established with the introduction of 'standard lots'.

47. Mineral jelly was originally included in the composition to provide lubrication of the shell in the rifled gun barrel, but it was in fact completely consumed during the combustion of the propellant. It was later, and unexpectedly, found to have the valuable property of absorbing the (acidic) products of decomposition of nitrocellulose and nitroglycerine which might otherwise have shortened the storage life of the cordite, and it remained an ingredient of Land Service propellants for this reason until 1935 when it was replaced by carbanite, although it was partially reintroduced during the 1939-45 War to economize in the use of carbanite.

48. The original Mark I cordite was produced in solid and tubular cords of various sizes and in flake form (by chopping solid cord), thus giving a good deal of ballistic control. (The size of solid cords was restricted by the difficulty of removing solvent from them as the diameter increased.) But the cordite had a high flame-temperature, which gave rise to excessive erosion of gun barrels, and so a modified cordite (Cordite MD) was produced, having an NG/NC ratio little more than a quarter of that in Mark I. This was cool enough to give an acceptable erosion but still hot enough to give rise to 'muzzle flash' as the products of combustion emerged into the atmosphere, a phenomenon found objectionable in the 1914-18 War. This problem was attacked by the Research Department, Woolwich, after that war and resolved by incorporating into the propellant matrix a large proportion of finely divided nitroguanidine (known in the Service as Picrite), which markedly cooled the propellant whilst giving rise to products of combustion which were rich in incombustible gases. Production of picrite and of 'flashless' cordite (Cordite N) was established at the Royal Gunpowder Factory some years before the 1939-45 War, by which time sufficient information had been acquired to enable a very large picrite factory to be built at Welland, in Canada, where sufficient electric power was available for the production of the essential raw material, calcium carbide.

49. In the 1914-18 War supplies of acetone proved inadequate for the scale of production of cordite then required. Relief was obtained when the Weizmann fermentation process for acetone became available, but meantime the Research Department, Woolwich, had developed Cordite RDB, based on the known ability of ether/alcohol mixtures to gelatinize nitrocellulose of 12.2% nitrogen content; this solvent and nitrocellulose replaced the guncotton and acetone used in the manufacture of the earlier cordites.

#### *Solventless Cordite*

50. It is, at first sight, surprising that Abel and his colleagues when developing cordite did not adopt Nobel's idea of mixing nitrocellulose and nitroglycerine in water, but it is probable that they did not wish to risk infringing his patents, apart from the possibility that they may have found it difficult to dry such a mixture without excessive gelatinization of the nitrocellulose in presence of the high proportion of nitroglycerine which they were using. Later, German explosives technologists seem to have appreciated the problem associated with the use of solvents in cordite manufacture, notably the tendency of cords to shrink, distort and even crack during drying, particularly as the cords approached 0.2 inch (5.08 mm) diameter. They therefore adopted the concept of wet mixing and gelatinization on hot rolls, but they went further than Nobel and, choosing a nitrocellulose of lower nitrogen content than that used by Abel, they extruded the sheeted material from a press having a heated cylinder to give a 'solventless' cordite. They used this process during the 1914-18 War.

51. After the war, the Research Department and the Royal Naval Cordite Factory studied the German process and were particularly impressed with its suitability for producing the thicker sticks of cordite which were preferred on ballistic grounds for the large naval guns which were then favoured. In 1927, having in mind also the possibility of using wood-nitrocellulose (which would give a somewhat softer hot-rolled sheet than that based on cotton NC), the 'solventless' process was adopted for Naval cordites. The product was called SC (solventless cordite), and later a composition of higher calorimetric value, HSC, was also developed. These compositions included carbanite (Chapter 6, para. 113) as a stabilizer/gelatinizer. In the period before the 1939-45 War these compositions were extruded in 2.75 inch (69.9 mm) diameter sticks for use in unguided rockets, and, in fact, the process was vital to the development of the range of 2 inch (50.8 mm) and 3 inch (76.2 mm) aircraft rockets and 3 inch (76.2 mm) and 5 inch (127 mm) unguided rockets employed during that war.

52. During and after the 1939-45 War numerous modified 'solventless' compositions were developed; but reference must be made to an important—allegedly chance—discovery made in the USA shortly

after the war that addition to compositions of low or moderately low calorimetric value (say, 450 to 900 cal/g) of 1 or 2% of certain lead compounds resulted in valuable modifications of the rate-of-burning/pressure relationships of the compositions. The phenomenon was named 'platonization', because the rate of burning remained substantially constant over a range of pressures, giving a horizontal plot on graph paper; the lead compounds were described as 'ballistic modifiers'. The pressures involved were relatively low, but of interest in the design of rocket motors (Chapter 12).

#### *Single-base powders*

**53.** It is now convenient to revert to the topic of single-base powders (that is, those propellants based primarily on nitrocellulose only, without nitroglycerine), of which Vieille's Poudre B was the first example. This type of powder was considerably developed in the commercial sphere in many countries and was adopted by the American Services, which did not favour the introduction—particularly into their Naval Service—of propellants containing nitroglycerine.

#### *NC powder, or 'Pyropowder'*

**54.** The American procedure for the production of a nitrocellulose composition was essentially that of Vieille, using alcohol/ether, but employing improved techniques and incorporating into the paste diphenylamine, to act as a stabilizer. The paste was extruded into thin cords which were at once chopped into short lengths before drying. The powders so produced, though substantially smokeless, had the following disadvantages:

- (1) the drying process could not readily remove all residual solvent, and further loss of solvent tended to occur during storage with, at best, accompanying changes in ballistic properties of the powder and, at the worst, embrittlement of the powder which might then break up in the gun and give high pressures
- (2) the powders were hygroscopic with consequent effect on their ballistic properties.
- (3) they gave considerable 'muzzle flash'.

However, they were employed in the British Services during the 1914-18 War, because of the large requirements for propellants; they were in multitubular form and were known as NCT. An improved powder of this type, known as NCY, was made in Britain.

#### *NH and FNH Powders*

**55.** These powders were developed by the Americans soon after the 1914-18 War to overcome the problem of the hygroscopicity of the pyropowders, and to this end they contained dinitrotoluene and dibutyl phthalate. However, the first powder of this type, designated NH, still gave excessive muzzle flash, and thus FNH/P was developed, containing potassium sulphate to suppress flash; but even this was not adequate in big guns, in which it was necessary to use a supplemental 'charge' of flash-reducing potassium salt.

**56.** NH and FNH powders were imported into this country during the 1939-45 War, partly for use in the 50 'lease-lend' destroyers and partly for supply reasons. They were later made in the United Kingdom.

#### *Rifle powders*

**57.** The nitrocellulose powders for small arms are of such small size that it is not feasible to control their rate of burning by modifying their shape. Accordingly, recourse was had to coating the grains to retard their initial combustion so that the rate became faster as the surface of the grain became smaller. The Americans developed these 'progressive' powders (known as Improved Military Rifle, or IMR powders) during the 1914-18 War.

**58.** In the British Services, however, a fine tubular cordite, known as MDT 5-2, continued to be used for rifles and machine guns until developments in automatic weapons between the two World Wars necessitated a more powerful and more easily loaded propellant. By agreement with Du Pont's in America, Imperial Chemical Industries (Nobel Division) developed progressive-burning single-base propellants called Nobel Rifle Neonite, NRN; these are essentially gelatinized nitrocellulose, stabilized with diphenylamine and coated with up to 4% of dimethyldiphenylurea (methyl centralite). These powders were made on a large scale in this country during the 1939-45 War, and have since been the subject of steady improvement (Chapter 8).

**59.** Between the two World Wars the firm Olin Mathieson, in America, developed 'Ball Powders' for small arms, and some of these came into use in the British Services during the Second War. They were made by dissolving a suitable nitrocellulose in a volatile solvent (for example, ethyl acetate) and adding the solution to stirred water containing a colloid such as gelatine, when the suspended droplets of NC solution became spherical; if the water was then heated the solvent was driven off and the droplets hardened to give spheres of gelatinized NC. The process could also be used for compositions containing some nitroglycerine (up to 10% of the NC) and was adopted in ROF Bishopton about 1956 following on

work by the Explosives Research and Development Establishment to improve the stability of ballistics of the product.

#### *Composite propellants*

**60. Plastic propellants:** From the historical standpoint it is now convenient to leave the topic of propellants based on nitrocellulose and take up the theme of what are now known as 'composite propellants' that is, propellants which are basically physical mixtures of fuels and oxidants. Gunpowder was of course a composite propellant, but it had not very desirable physical properties and could only be pressed into moderately strong shaped pieces by virtue of the plasticity of its sulphur content and of traces of tarry matter in the charcoal which it contained.

**61.** It has been said that cordite was used as the propellant in unguided rockets in the British (and other) Services in the 1939-45 War. But the cordite charges had to be loose in the motor cases, if only to overcome problems of differential thermal expansion during temperature changes in storage and in use. There was thus a lower loading density than could be desired, and this gave rise to the concept of a plastic propellant which could be pressed into the motor and would, by reason of its physical properties, cope with thermal expansion effects while occupying the available space more effectively. This concept was first attempted by incorporating into a soft NC/NG matrix quantities of sodium nitrate, but the resulting compositions were found to be insufficiently stable, so that gas bubbles formed between the motor wall and the propellant charge with the result that the case wall was burnt through at such spots. It therefore appeared that a non-reactive fuel-binder was required in which to incorporate the oxidant, and consideration was given to the field of hydrocarbon polymers which had begun to appear commercially before the war. The first choice was polystyrene, which was incorporated with sodium nitrate, then ammonium nitrate and, finally and best, ammonium perchlorate.

**62.** A stoichiometric composition of hydrocarbon, which may be regarded as  $(CH_2)_n$ , and ammonium perchlorate ( $NH_4ClO_4$ ) was too 'hot' and too fast-burning for most purposes, and ammonium picrate was added as a coolant and rate-moderant. However, it was found that polystyrene-based plastic propellants became brittle at temperatures of the order of  $-10^\circ C$  to  $-15^\circ C$ , whereas a wider temperature range was required by the Services. By this time polyisobutylene was available in this country (although not made here), and it was known to have a much lower brittle point than polystyrene (about  $-80^\circ C$ , in fact). Accordingly it was adopted as the fuel-binder. However, because of the high solids content of the propellant (about 87.5%) the effective brittle point of the composition is not as low as that of the binder, especially under conditions of shock (for example, if the motor is roughly handled or at the moment of ignition, when the igniter produces a shock wave adjacent to the surface of the propellant). However, by suitable choice of propellant composition, charge design and igniter design, effective operation can be secured at temperatures as low as  $-30^\circ C$  to  $-40^\circ C$ .

**63. Rubbery composite propellants:** After the 1939-45 War the Americans took up the subject of composite propellants, and, as during that war their petroleum chemical industry had done a great deal of work on synthetic rubbers, they aimed to produce a rubbery, rather than a plastic, propellant since its physical properties, at least at normal temperatures, should impose fewer restraints on the size of motors — a plastic system can reach a point at which it will deform ('flow') under its own weight. After much research, some of it directed specially to meeting the requirements of the propellants industry, they found rubbery polymers which enabled them to develop propellants which would permit motors to function at temperatures as low as  $-60^\circ C$ . Many of the American polymers were not simply hydrocarbons but contained in their structure oxygen or sulphur, so that their calorimetric value per unit weight was lower and thus a greater proportion of polymer could be present with the ammonium perchlorate; but even when additional coolant was required the United States tended to use non-explosive materials rather than ammonium picrate.

**64.** In more recent developments (on both sides of the Atlantic) it has become usual to incorporate in composite propellants a proportion of aluminium powder, the heat from the combustion of which further expands the gaseous products of combustion.

#### *Cast-double-base propellant (CDB)*

**65.** A little later than the first work on composite propellants the first steps were taken to develop a method of producing a cordite-like material by a casting process. The obvious way to achieve this end was to make up a slurry of a pyropowder (essentially an already gelatinized nitrocellulose) in nitroglycerine, pour it into a mould and put the mould into an oven at a reasonable temperature to enable the nitrocellulose to swell. In fact, this method gave promising results, the cold product being a horny mass occupying a somewhat increased volume in the mould. In the years immediately following the war the US took up this idea and developed a technology which enabled them to produce loose propellant charges (say, 30 inches in diameter) having internal burning surfaces of desired shapes, for example, an axial star shape. It was necessary to change the stabilizer normally used in pyropowders, because diphenylamine is not compatible with nitroglycerine; but it was found that these propellants could be made to give the phenomenon of 'platonization' (Chapter 12) if small proportions of certain lead compounds were included in the compositions, as with certain cordites.

66. It is necessary to be able to prevent combustion on some surfaces (particularly outer cylindrical surfaces) of loose charges and, as with cordite, this did not prove easy with CDB charges. Relatively non-combustible sheathing ('inhibiting') materials could be found (for example, cellulose acetate, ethylcellulose, rubbers), but (even if these materials did not absorb nitroglycerine excessively) there was difficulty in finding adhesives which were unaffected by NG.

67. Of course, CDB compositions could, more easily than cordite compositions, be made relatively soft so that, if they could be stuck to the walls of the rocket motor, differential thermal expansion would be less important. As motors became larger this became an increasingly desirable technique, but the problem of adhesives which would neither react with nor be softened by NG has not yet been fully resolved, although cast-in-situ CDB charges so bonded to rubber-lined motors have come into use.

#### *Composite-modified cast-double-base-propellant (CMCDB)*

68. It has been said that advantages were seen in the addition to composite propellant systems of finely divided aluminium. By about 1955 attempts were being made to secure similar advantages for CDB systems. This, however, necessitated the addition to the CDB matrix not only of aluminium but also of ammonium perchlorate to provide the oxygen to burn the aluminium, and this in turn rendered it necessary again to seek a new stabilizer for the propellant, since it appeared that ammonium perchlorate was not fully compatible with nitroglycerine. Thus, within the next ten years, cast-in-situ CMCDB propellant charges had come into use.

#### **Ignition and initiation**

69. During all the years that gunpowder was used until the early part of the 19th century it had been necessary to ignite it by the direct application of a flame, a red-hot metal bar or, in the later phases, a hot spark from a flint-lock. With cannon it had been found advantageous to insert into the touch-hole a prefilled 'firing tube' of gunpowder in which the combustion could build up velocity before communicating itself to the main charge.

70. Some sensitive explosive substances had been discovered in the 17th and 18th centuries; for example, mercury fulminate was first made by Kunckel in the 17th century and its preparation and properties were clearly described by Howard in 1800, while Glauber had precipitated his picric acid as the lead salt. But no serious attempt was made to apply such substances to the ignition of gunpowder, even in small arms, until the early 19th century. Although various subsequent claims were made that similar methods had been used earlier, the first patent for the use of a detonating powder was taken out by the Reverend A J Forsyth (British Patent No. 3032 of 1807); this claimed the use of a small quantity of a detonating powder in a touch-hole in which it was struck by a metal rod. From this first idea Forsyth went on to propose the use of measured quantities of his powder (a mixture of mercury fulminate and potassium chlorate) enclosed in thin copper caps. This idea did not at once meet with the approval of military circles, but it was developed by the makers of shotguns and thence came into Service use, the first Service composition being 50% potassium chlorate, 33% mercury fulminate and 17% powdered glass. By 1864 the improved composition 37.5% potassium chlorate, 37.5% mercury fulminate and 25% antimony sulphide had been adopted for small arms, the composition being enclosed in a cross-shaped copper container (about 1/4-inch across and 1/4-inch thick) which was carried separately from the powder and shot and placed under the hammer of the musket or rifle lock just before firing.

71. For cannon, 'percussion tubes' were developed and were authorized for use in the British Service about 1840; but muzzle-loading and firing through a touch-hole had to continue until the mechanical problems of breech-loading and firing by an internal cap could be solved. A fairly successful pin-fire, breech-loading shotgun was made in 1836, but flame leakage past the striker mechanism was troublesome.

72. In 1866 the Snyder rifle was adopted for the British Army, and it was decided that a brass cartridge case should be used having a percussion cap incorporated in the base. Between 1885 and 1889 the famous '0.303' ammunition came into use; it still used gunpowder as the propellant, but the cap composition was now:

Mercury fulminate	15%
Potassium chlorate	35%
Antimony sulphide	45%
Sulphur	2.5%
Mealed gunpowder	2.5%

73. The first percussion tube for guns was a rather cumbersome device which was to be linked to the existing firing tube, but in 1845 percussion caps were fitted to the latter. About 1860 'friction tubes' were introduced; these consisted of a friction bar coated with a mixture of potassium chlorate, antimony sulphide and sulphur, housed in a body containing mealed gunpowder, the bar being linked to a firing lanyard. The first 'galvanic tube' was approved for proof and experimental firings in 1856, and Abel developed the first electrically fired tube which was adopted for Service in 1866; this contained copper

sulphide, copper phosphide and potassium perchlorate, but it required a high voltage. Low-voltage electric tubes were adopted in 1878. During all this time some escape of gases around the tube on firing was unavoidable, but in 1882 the 'vent sealing tube' was introduced; its design was based on that of the brass cartridge case for rifles, the expansion of the brass body preventing the escape of gases.

74. In 1867 Nobel used as detonators for his NG-based explosives thin-walled copper tubes containing mercury fulminate and having lengths of gunpowder-filled delay fuze crimped into their open ends. In time, the principles of electric ignition were applied to this system also.

75. In 1890-91 Curtius first prepared lead, silver and mercury azides. The hazards of manufacture and handling prevented the adoption of lead azide for many years, but it came into use in the German, and then the British, Services in the 1914-18 War, and its use as a replacement for mercury fulminate was subsequently widely developed because fulminate tended to degrade on long storage in hot climates. The British Services preferred to us 'pure' lead azide, but in the USA the preference was for 'dextrinated' azide (prepared by precipitation in presence of dextrin) as being less sensitive; however, dextrinated lead azide is only about 89% as powerful as the pure compound (necessitating the use of larger detonators) and it is somewhat hygroscopic. Lead azide (see Chapter 9) is the basis of a number of modern Service detonators, although several other compositions have been developed to meet special needs.

76. It was said that the velocity of combustion of an explosive depends, *inter alia*, on the degree of confinement of the substance, and in a device known as a 'gaine' it can be seen how the velocity builds up to a maximum. If a length of steel tube (say of 0.1 inch bore and 0.5 inch external diameter) is filled with tetryl, stemmed in, and is then initiated at one end it will be found that the diameter of the tube has gradually expanded along the tube, corresponding to the increased violence of the explosive effect as the state of 'detonation' is achieved. This principle was employed in early fuzes for shell, but when TNT was adopted it was necessary to transmit the detonation from the gaine to the TNT through a 'booster' system of tetryl pellets. It is usual to find boosters of tetryl, RDX/Wax or PETN/Wax in most large modern explosive stores to ensure that the initial shock from the detonator is transmitted effectively to the main charge.

## Pyrotechnics

### Development

77. According to early Chinese writings some forms of firework, probably based on 'weak' gun-powders (that is, those of low saltpetre content), were known before 1000 AD and they were developed into devices which, while no more than toys from the modern standpoint, could be used to cause alarm among enemy troops.

78. In Europe, probably owing to the high cost of gunpowder in its earlier stages, the development of mere fireworks proceeded rather slowly, but it is known that early in the 17th century mixtures of saltpetre, sulphur, charcoal and antimony sulphide with various oils and resins were being used to make brightly burning 'stars', and that iron filings were used in similar compositions to give sparks, and verdigris to colour the flame. Rockets, pin-wheels and candles were soon being made, and in the 18th century large firework displays were given on State occasions, many of the effects being due to advances by Ruggeri, in Italy. At the beginning of the 19th century potassium chlorate was used to increase the brilliance of coloured stars, and calcium and sodium salts were employed for the colour effects. Magnesium was used to give increased brilliance in 1865 and aluminium in 1894; these metals were used in aircraft flares in the 1914-18 War, but their wider introduction into military pyrotechnics came later. Meantime from about the middle of the 19th century, signal rockets (both those showing coloured lights and those giving sound effects) began to be of military value, and such rockets were much developed in the 1914-18 War. Between that war and the end of the 1939-45 War great advances were made in this country in the art of military pyrotechnics (both illuminants and smokes), and these have been continued since 1945, notably by the introduction of new materials to replace the cellulosic ones used in the casings of earlier stores and by the adoption of rubbery fuel-binders to replace such materials as starch and lactose and, at the same time, to confer improved physical properties on the compositions and to render them more water-resistant.

### Unguided weapons

79. Although it will not further advance what has already been said of the history of propellants, it is convenient at this point to say something about the history of the more offensive military rockets which, during the 1939-45 War came to be known as 'unguided weapons', but which an earlier age had regarded as an offshoot of pyrotechnics. It has been said that the Chinese had at an early date made rudimentary rockets to be projected among enemy troops to create panic. This idea does not appear to have been taken up in the West, but by the 18th century the Indians had developed explosive as well as incendiary rockets, based on gunpowder and having bodies some 8 to 12 inches in length and 1½ to 2 inches in diameter. Such weapons were found troublesome by the British troops then in India, and in due time Sir William Congreve was invited by the Ordnance Office to study the subject. In 1805 he first devised a

RESTRICTED

systematic construction of 'pyrotechnical' projectiles which, because he realized the importance of the fact that their propulsive force exerted no reaction at the point of launch, he felt they would be valuable arms on shipboard as missiles equivalent in destructive power to the heaviest cannon of the day. In fact, the range and accuracy of his rockets was equal to that of any gun of the period, and at Boulogne in 1806, at Copenhagen and Walcheren in 1807 and at Leipzig in 1813, the British used them to great advantage. His original rockets were constructed of laminated paper, but he soon turned to iron; the 32-pounder (total weight) was the size mostly used and was designed to be explosive-, incendiary- or shrapnel-armed, having a range of nearly 3,000 yards. In 1864 Congreve's rockets were superseded in the Service by those of Boxer, which gave way to Hale's rockets in 1866. In spite of the improvements in artillery some development of rockets continued, but on the outbreak of the 1914-18 War all patterns then in existence were declared obsolete. Nothing noteworthy was then done about offensive rockets until about 1930-35 when, as aircraft flew faster and higher, and might be expected to be used in larger numbers in a future war, it was realised that the rocket might usefully supplement the anti-aircraft gun on the ground—and later that it might be a useful aircraft weapon. With solventless cordite available as propellant and employing improved engineering skills, these concepts were developed for use in the 1939-45 War.

CHAPTER 3

Classification of explosives

CONTENTS

	<i>Para</i>
<b>Introduction</b> .....	1
<b>Home Office list of authorized explosives</b> .....	3
<b>Classification of Crown military explosives</b> .....	5
<i>Responsible authorities</i> .....	5
<i>Explosives classification by groups</i> .....	9
<i>Storage by groups and combinations of groups in same building</i> .....	11
<i>Quantity-distance categories</i> .....	13
<i>Fire-fighting class</i> .....	14

Tables

<i>No</i>	<i>Page</i>
1 Service classification of explosive stores .....	5/6

## CHAPTER 3

## Classification of explosives

**Introduction**

1. It is to be expected from the nature of explosives that their processing, storage and transport constitute risks to society and that, accordingly, regulations have had to be made for the protection both of those directly engaged with explosives and of the community at large. So far as concerns the manufacture, storage and transport of explosives, power to control these aspects is exercised by virtue of the Explosives Acts of 1875 and 1923, which confer on the Home Office the duty of recommending to the Privy Council the making of regulations relating to industry and commerce, and on local authorities the duty of supervising the application of certain such regulations within their areas. In the exercise of Crown privilege, the appropriate Ministers make corresponding regulations to control the manufacture, storage and transport of Crown explosives and explosive stores. While the provisions of the Explosives Acts and of the principal Orders made thereunder are set out in the 'Guide to the Explosives Acts, 1875 and 1923' (Bibliography), the Explosives Regulations of the appropriate Ministries should be studied by all having duties in the fields of research, design, development, manufacture, inspection and storage of military explosives and explosive stores in order to avoid falling into error and to lessen the burden falling on Departmental and Establishment Safety Officers (see also Chapter 14).

2. The Explosives Acts call for the classification of all explosives, and this classification in turn governs the many conditions under which they may be stored and transported. For the purposes of industry and commerce the classification made by the Home Office is based primarily on the composition of the explosives, and there may be considerable variations in the permissible standards of handling and storage of individual explosives in the same class. In the Services a different classification is employed (for example, see AP 110A-0102-1, Explosives Regulations), partly to cater for the much wider range of explosives and explosive stores used and partly to ensure more careful segregation of those requiring special precautions.

**Home Office list of authorised explosives**

3. HM Chief Inspector of Explosives, Home Office, publishes (HMSO) a 'List of Authorised Explosives', and it is illegal to handle or transport explosives in the United Kingdom until they have been 'authorised'. The classification is into seven classes, some with sub-divisions. These in brief are as follows:

*Class 1 Gunpowder class*

This class is exclusively composed of gunpowders.

*Class 2 Nitrate-mixture class*

This comprises mechanical mixtures (not included in Classes 1, 3, 4 or 5) of a nitrate or perchlorate with non-explosive carbonaceous and other materials.

*Class 3 Nitro-compound class*

The term 'nitro-compound' means any chemical compound possessed of explosive properties or capable of combining with metals to form an explosive compound which is produced by the nitration of any carbonaceous substance. The class comprises such nitro-compounds whether or not mechanically mixed with other substances, and is subdivided into the following divisions:

*Division 1*

Explosives consisting wholly or partly of liquid nitro-compounds

*Division 2*

Explosives containing any nitro-compound not included in Division 1

*Class 4 Chlorate-mixture class*

This class includes any explosive containing a chlorate, and is sub-divided into two divisions:

*Division 1*

Any chlorate mixture which consists partly of some liquid nitro-compound

*Division 2*

Any chlorate mixture which is not comprised in Division 1 (but, see also Class 5, Division 1)

*Class 5 Fulminate class*

The term 'fulminate' means any chemical compound or mechanical mixture, whether included in the foregoing classes or not, which, as a result of its great susceptibility to detonation, is suitable for employment in percussion caps or detonators, or is specially dangerous. The class is sub-divided into two divisions:

*Division 1*

Fulminates of silver and mercury and preparations containing them; mixtures of a chlorate with phosphorus or with sulphur.

*Division 2*

This division comprises an extensive list of sensitive substances.

*Class 6 Ammunition class*

The term 'ammunition' is defined fully, together with the terms 'percussion cap', 'detonator' and 'safety fuze'. The class is sub-divided into three divisions:

*Division 1*

Safety cartridges, safety fuzes (which burn without detonation), safety ignition devices and percussion caps (but not detonators).

*Division 2*

Ammunition which does not contain its own means of ignition and is not included in Division 1.

*Division 3*

Ammunition containing its own means of ignition and which is not contained in Division 1.

*Class 7 Firework class*

Comprises firework compositions and manufactured fireworks. The class is sub-divided accordingly into two divisions:

*Division 1*

Firework compositions

*Division 2*

Manufactured compositions

4. The foregoing description of the Home Office classification is not fully comprehensive and the original List should be consulted whenever a particular case arises.

**Classification of Crown military explosives**

*Responsible authorities*

5. The authority responsible for the classification of all Crown military explosives and explosive stores is the Explosive Storage and Transport Committee (ESTC), which is chaired by the President or a Vice-President of the Ordnance Board. The Committee has technical advisers, and its membership is composed of representatives of the Service Departments, the Home Office and the Ministries and Authorities concerned with air, land and sea transport and with the manufacture and supply of munitions. The system of classification adopted by the Committee is set out and explained in its 'Comprehensive Classified List of Government Explosives' (CCL); it aims at ensuring that all Service explosives and explosive stores are at all times properly classified for the purposes of transport, storage, safety distance and fire-fighting.

6. 'Permanent ESTC classification' is reserved for explosive stores that have been approved for service or supply purposes. Such classifications appear in the CCL.

7. 'Temporary ESTC classification' is given to stores under development, and is notified by the ESTC to those known to be interested.

8. 'Provisional classification' is issued for experimental explosive stores to cover their use in particular establishments and their transport under 'control' (that is, by road under the immediate supervision of Government employees and with Government drivers) between establishments. This classification need only be in terms of the 'explosives group', 'safety-distance category' and 'fire-fighting class', and may be issued by the Head of an Establishment.

*Explosives classification by groups*

9. Whilst it is well to know that special categorization exists to cover transport by rail and sea of explosives and ammunition, and can be found in CCL and in the Departmental Explosives Regulations, it is more important for most purposes to know something of the classification in terms of 'explosives group', 'safety distance category' and 'fire-fighting class'.

10. Explosives classification by groups governs the decisions which must be taken as regards the nature of buildings to be used for storage and the precautions to be observed. The characteristics of the groups and storage conditions specified are summarized in Table 1.

**Table 1**  
**Service classification of explosive stores**

Group	Characteristics	With own means of ignition	Storage conditions	Examples
1	Explosives bearing a fire and explosion risk and relatively sensitive to spark or friction, the explosives being in bulk or contained in a paper or fabric wrapping (that is, other than those contained in a filled metal component)	No	Magazine	Gunpowder
2	Explosives likely to decompose, bearing an explosion risk	No	Magazine but may be placed in an explosives storehouse	Blasting explosives
3	Explosives liable to decomposition, bearing a fire risk	No	Magazine but may be placed in an explosives storehouse	Cordite
4	Stable explosives, bearing a fire or explosion risk	No	Magazine but may be placed in an explosives storehouse	TNT, Plastic explosive
5	Unboxed shell or bombs, filled HE, gunpowder or star composition, plugged or fuze		Explosives storehouse	
6	Boxed ammunition containing HE, gunpowder and propellants only	Possibly	Explosives storehouse	SAA and gun ammo, rocket motors, puffers, igniters
7	High capacity ammunition, filled HE, plugged; with or without their components in their packages	No	Explosives storehouse	Demolition charges
7a	High capacity ammunition, filled HE	Yes	Explosives storehouse	
8	Mortar grenades and rocket ammunition (filled HE or gunpowder) and HE charges, with or without propellants and components in their packages	Possibly	Explosives storehouse	Unboxed rocket motors, grenades
9	Pyrotechnics	Possibly	Explosives storehouse	Tracking flares, ramjet igniters, signals
10	Detonators and initiatory compositions		Explosives storehouse	
11	Incendiary and smoke ammunition not containing phosphides, white phosphorus, flammable liquids or gels; with or without components in their packages	Possibly	Explosives storehouse	

Table 1 (cont.)

Group	Characteristics	With own means of ignition	Storage conditions	Examples
12	Ammunition containing phosphides or white phosphorus, with or without components in their packages	Possibly	Explosives storehouse	
13	Chemical ammunition, with or without components in their packages	Possibly	Explosives storehouse	
14	This is a Naval storage group on HM ships only			
15	Incendiary ammunition containing flammable liquids or gels, but not containing phosphides or white phosphorus; with or without components in their packages	Possibly	Explosives storehouse	
16 and 17	These groups relate to atomic weapons			

*Storage by groups and combinations of groups in same building*

11. Below is given a summary of the permissible storage groups. For more detailed information, reference should be made to ESTC Summary No 1, 'Group classification system for government explosives'.

12. Explosives of the following groups may be stored in the same building, or the underground equivalent, subject to the limitations on groups which may be stored in underground areas as given in paragraph 4 of 'Safety Conditions for Underground Storage of Government Explosives':

- (1) Group 1 may be stored under magazine conditions with Groups 2, 3, 4 and 7 if the packages containing these other groups are free from external iron or steel or an aluminium alloy which contains more than one per cent of magnesium.
- (2) Groups 2, 3, 4 and 7.
- (3) Group 3 explosives should be stored alone, except as provided for at (4) and (6).
- (4) Groups 3, 5, 6, 7A and 8 provided, in the case of Group 3, the explosive content is less than 60 per cent of the weight as packaged (this excludes bulk packed explosives of Group 3).
- (5) Groups 5, 6 and 8, when not containing their own means of ignition, may be stored with Group 7.
- (6) Group 6 explosives which belong to the Safety Class may be stored with Groups 2 to 15 inclusive, in an explosive storehouse. If the packages containing the Group 6 Safety Class explosives are free from external iron or steel or an aluminium alloy which contains more than one per cent of magnesium, they may also be stored with Group 1 in a magazine.
- (7) Group 7 may be stored with Group 7A at the discretion of the Service concerned. However, ESTC Summary No 1 should be consulted.
- (8) Groups 9 and 11.
- (9) Group 10 (in the form of detonators, etc., as packed for the Services) with Groups 3, 5, 6, 7A and 8 [as given at (4) above], subject to those of Group 10 being separated from the others by a partition or inside traverse capable of preventing propagation of explosion from Group 10 to the others.
- (10) Group 12 with Groups 9 and 11, if those of Group 12 are separated from the others by a fire-proof partition wall.

(11) Group 13 with Group 6, Safety Class, as provided for in (6).

(12) Group 15 with Group 6, Safety Class, as provided for in (6).

*Quantity-distance categories\**

13. The quantity-distance category classification is used in deciding the distances between storage buildings or dumps, and between them and other premises, in relation to the quantities of explosives stored. The specifications for category X, Y, Z and ZZ are summarized below:

*Category X*

Those explosives which have a fire risk, a slight explosion risk, or both, and the effect of which will be local.

*Category Y*

Those explosives which have a mass fire risk or a moderate explosion risk, but do not have a risk of mass explosion.

*Category Z*

Those explosives which have a mass explosion risk with serious missile effect.

*Category ZZ*

Those explosives which have a mass explosion risk with minor missile effect.

*Fire-fighting class*

14. Arrangements have been made between the Service Departments, the Home Office and the local fire authorities to indicate by agreed symbols on all buildings or dumps containing explosives the relevant fire-fighting classification which indicates the nature of the risks involved.

*Class 1*

Explosives which must be expected to explode *en masse* immediately the fire reaches them

*Class 2*

Explosives which are readily ignited and burn with great violence, without necessarily exploding

*Class 3*

Explosives which may explode *en masse* but, compared with those of Fire Class 1, may be exposed to a fire for some time before exploding. There will be a blast and fragment hazard

*Class 4*

Explosives which burn fiercely and give off dense smoke with, in some instances, toxic effects. There is no risk of mass explosion.

*Class 5*

Explosives which are used in association with toxic substances as chemical weapons

*Class 6*

Explosives which may be exposed to a fire for some time before exploding. This risk of mass explosion is not involved, but small sporadic explosions will occur with increasing frequency as the fire takes hold. There will be a fragment hazard, but not a serious blast risk

*Class 7*

Explosives which involve a combined inflammation, toxic and corrosive hazard. They may be exposed to a fire for some time before exploding. The risk of mass explosion is not involved, but explosions will occur with increasing frequency as the fire takes hold. There will be a fragment hazard arising from pressure bursts, but not a serious blast risk. Fire-fighting personnel must wear full acid-proof protective clothing and self-contained breathing apparatus of a type to withstand nitrous fumes

\* See also Chapter 14, Appendix C, 'Classification of Explosives Hazards'.

## CHAPTER 4

## Theory of detonation and properties of explosives

## CONTENTS

## DETONATION THEORY

## Preliminary considerations

	<i>Para</i>
Rates of burning .....	1
Early theories of detonation .....	3
Qualitative description of detonation .....	7
Need of thermochemical data .....	9

## Quantitative theory

The equation of state .....	10
Thermochemistry of explosions .....	14
<i>Heat of explosion</i> .....	15
<i>Temperature of explosion</i> .....	17
<i>Effect of oxygen balance</i> .....	20
<i>Thermochemical pressure</i> .....	26
<i>Summary of important thermochemical properties</i> .....	27
<i>Simple applications of thermochemistry</i> .....	28

## Hydrodynamic theory of detonation

The employment of Rankine-Hugoniot relations .....	39
Outline of hydrodynamic detonation theory .....	44

## PROPERTIES OF EXPLOSIVES

Factors controlling initiation of detonation .....	56
Values of explosives parameters .....	61
<i>Velocity of detonation</i> .....	62
<i>Calorimetric value of explosive</i> .....	66
<i>Power of explosive</i> .....	67
<i>Volume and nature of the products</i> .....	73
<i>Pressure of explosion or detonation pressure</i> .....	75

## Illustrations

<i>Fig</i>		<i>Page</i>
1	Application of K-W and S-R rules to unconfined and confined explosions .....	11
2	Rankine-Hugoniot curve for completely reacted explosive ( $n = 1$ ) .....	12
3	A sectional diagram of the steady detonation waves from the stand-point of an observer accompanying the wave .....	14
4	Rankine-Hugoniot curve of reaction products .....	16
5	Reaction-wave, steady-zone conditions .....	16
6	Diagram of Mettegang apparatus .....	18
7	Diagram of Dautriche apparatus .....	19
8	Diagrammatic sketch of Hopkinson pressure-bar apparatus .....	21

## Tables

<i>No</i>		
1	High-temperature second virial coefficients of gaseous products of explosion .....	5
2	Thermochemical properties of single explosive compounds .....	9

## CHAPTER 4

## Detonation Theory

## Preliminary considerations

## Rates of burning

1. When explosive substances other than gunpowder became available in the later part of the 19th century, attention was drawn to remarkable differences between the combustion of some of those substances and that of gunpowder. Whereas the latter, if ignited in the open, burned reasonably slowly (that is, 'deflagrated') without appreciable effect on the surface on which it had been placed, some of the new substances (for example, nitroglycerine and blasting gelatine) if similarly ignited in the open burned with a degree of rapidity and violence characterized by the name 'detonation' and might shatter the surface on which they had stood. Of course, such a comparison might have been made earlier between the behaviour on burning of gunpowder and mercury fulminate, but no doubt the violence of the latter had come to be taken for granted as a feature of its use as an initiatory, or 'primary' explosive, and it was still obviously more easily brought into effect than the violence of the new substances, which contained only carbon, hydrogen, oxygen and nitrogen and which came to be known as 'high' (or, later, 'secondary') explosives.

2. Further studies showed that some at least of these new explosives might either deflagrate or detonate according to the method of initiation or the quantity of explosive involved. If the mass of explosive was small, thermal ignition usually led merely to deflagration; but if the mass exceeded a critical value, burning was so accelerated that a shock wave-front was set up and detonation ensued. It was then realized that the primary explosives merely had very low critical masses; while the critical masses of some secondary explosives might be of the order of a tonne under similar conditions of thermal ignition—though much less under conditions of heavy confinement or if brought to ignition by the intense shock from the detonation of a primary explosive. Again, a cordite, which will burn steadily from the surface inwards at a rate dependent on the chamber pressure in a device such as a gun or rocket (Chapter 12), may be caused to detonate if a suitable high explosive charge is applied to one end of a thick rod of it. Burned in a 'closed vessel' (to simulate a gun chamber), such a cordite (52% nitrocellulose, 45% nitroglycerine, 3% stabilizer) was found to have a burning rate constant of 0.0001 m/sec atmosphere; but it could be detonated unconfined in a rod of 1½ in. diameter with a detonation velocity of upwards of 7000 m/sec if 'primed' with a charge of tetryl.

## Early theories on detonation

3. At about the same time as the differences in rates of burning of explosives, together with the phenomenon of the detonation shock-wave, were being noticed, certain physical chemists were studying the velocities of gas explosions and attempting to work out a theory of the propagation in such systems of the detonation wave which had been observed in 1881 by Berthelot and Vieille and by Mallard and le Chatelier. In 1882 Berthelot attempted to account for detonation in gases by identifying the velocities of propagation with the mean molecular velocity in the reaction products at the explosion temperature. In 1885 he demonstrated, using an electric chronograph, that velocities of propagation of detonative reaction in explosives were of the same high order (a few thousand metres per second) as those in gases, and in both instances the velocities were characteristic of the system and independent of the initial temperature or pressure. In 1893 Dixon identified the velocity of propagation in gaseous explosions with that of sound in the hot reaction products; but, in a note to Dixon's paper, Schuster suggested an analogy between detonation waves and the (non-reactive) shock waves which had been discussed some 30 or 40 years earlier by Riemann and other mathematical physicists in their studies of the behaviour of matter when subjected to mechanical shock.

4. The velocities of detonation in gaseous systems observed by Berthelot and Dixon were, in fact, in close approximation to those calculated by them for molecular and sound velocities in the products at the theoretical temperatures of explosion. However, these coincidences were fortuitous, and Dixon's calculated velocities of sound were, in fact, generally too high because he had not been able to allow for dissociation in the gaseous products at the high prevailing temperatures.

5. However, both Berthelot and Dixon were right to focus attention on the products of reaction rather than on the undetonated gas, for it is the physical properties of the products which determine how rapidly the detonation shock-wave can be supplied with energy, and therefore what its velocity may be. This aspect is fundamental to the modern hydrodynamic theory of detonation.

6. The mathematicians studying shock waves had shown that compressional waves of finite amplitude, if suitably maintained in any normal fluid, must suffer a progressive increase of pressure and velocity gradients in the wave front and, in the absence of thermal and viscous energy transfer, soon become infinitely steep, that is, become 'shock' waves. Without using the mathematical analysis, this can be seen by the following argument in para 7.

**Qualitative description of detonation**

7. Compressional (as well as dilatational) waves of small intensity are propagated in gases at the relevant velocity of sound, which increases with rising temperature. Suppose that a column of gas is set in motion by accelerating a piston smoothly into it. The continuous movement of the piston may be approximated by a discontinuous movement in which, over each element of time, the piston velocity remains constant at the value appropriate to the middle of that time element. Each small movement of the piston transmits a small compressional wave which advances through the gas already set in forward motion and heated by its predecessors, and which therefore tends to overtake them. Consequently, the velocity pressure and temperature gradients in the front of the leading wave grow continually steeper with time and, in the absence of processes to dissipate energy (such as thermal diffusion and viscous transfer), must end by becoming infinitely steep and thus creating a finite effective discontinuity between the gas behind and in front of the 'shock wave'. The region of rapid pressure rise is called the 'shock front', and in it the pressure rise is infinitely rapid in the (theoretical) example of non-dissipation of energy. Once formed, the shock front advances with a supersonic velocity (with respect to the undisturbed gas) the level of which depends on the conditions behind. If the piston continues to accelerate, so does the front; if the piston settles to a steady velocity, the front finally does likewise. If, however, the piston decelerates, a rarefaction wave is formed ahead of it, the front of which moves with the local velocity of sound in the gas at each point and must therefore pass through the compression wave and overtake, and weaken, the shock front, which accordingly loses speed; if deceleration of the piston persists, erosion of the shock front will continue until its velocity has fallen to the sonic level.

8. In the foregoing argument it is clear that the velocity of the shock front is determined not by the conditions ahead but by those behind (*cf* the views of Berthelot and Dixon, para. 5). The shock wave is essentially unstable; it cannot maintain itself but depends for support on the piston, in the absence of which it must degenerate into a sound wave. But in exploding systems, stable detonation waves are a matter of common experience, with rarefactions always in their wake. In such systems it is necessary to conclude that release of chemical energy replaces the supporting energy of the accelerating piston, and that in some way it prevents rarefactions which arise in the products from overtaking the shock front. In fact, the really significant physical difference between deflagration and detonation is that in the former process the hot gaseous products of reaction move away from the reaction surface or zone whereas in the latter process they are moving in the same direction as the shock front, thus contributing to the build up of pressure and the maintenance of the shock wave.

**Need of thermochemical data**

9. A quantitative hydro-dynamic theory, along the lines of the foregoing argument, was applied successfully to gaseous explosions, but could not be applied to non-gaseous (that is, 'condensed') explosives in the absence of an equation of state to describe the reaction products at the prevailing very high pressures (hundreds of thousands of atmospheres) and temperatures (thousands of degrees Kelvin) and of corrections for the effect of the complex chemical equilibria in the reaction products under detonation conditions. When solutions to those difficulties had been devised the hydrodynamic theory for condensed explosives (at least, those containing only carbon, hydrogen, oxygen and nitrogen) was developed. It applied to explosives under complete confinement, or in such quantity that the material near the centre is 'self-confined'. It is purely mechanical and requires no hypothesis as to the nature of the decomposition or reaction of the molecules present in the explosive, but merely assumes that 'explosion' does begin and that the chemical energy liberated is sufficient to maintain the detonation wave. Then, from the equations of conservation of mass (the mass of the products is equal to the mass of the original explosive), of momentum and of energy, together with the physical theories of shock waves and with an (assumed) equation of state for the products of detonation at their high temperature and pressure, it proceeds to derive the velocity of the detonation wave, the detonation pressure and temperature and the specific volume of the products, together with their streaming velocity behind the detonation wave.

**Quantitative theory****The equation of state**

10. An important question to which attention must first be directed is the nature of the equation of state to be used in developing a hydrodynamic theory. At the high temperatures and pressures prevailing in a detonating explosive system the equation of state of an ideal gas,

$$pV = nRT \quad \text{--- (1)}$$

is not applicable ( $p$  is pressure,  $V$  is volume,  $T$  is absolute temperature, and  $nR$  is constant). Neither is the van der Waals equation

$$p(V - b) = nRT \quad \text{--- (2)}$$

generally adequate, since the covolume,  $b$ , cannot be treated as a constant independent of volume and temperature — although it is sometimes used to calculate detonation velocities for explosives at loading densities of 0.1g/ml with fair agreement with experiments.

11. Equations of state for extreme conditions are numerous and generally take the form:

$$p = nRT\rho \cdot f(\rho, T) + g(\rho, T) \quad \text{--- (3)}$$

where  $\rho$  is  $1/v$ . That of Boltzmann (derived from the kinetic theory of gases) in which the molecules are assumed to be 'hard' spheres, was used as the basis of an equation which was long employed and which took the form:

$$pV = nRT(1 + \frac{b}{V} + 0.625 \frac{b^2}{V^2} + 0.287 \frac{b^3}{V^3} + 0.193 \frac{b^4}{V^4}) \quad \text{--- (4)}$$

The fifth term of the series was added to the original Boltzmann equation. The function  $g(\rho, T)$  of equation 3 is given zero value. Calculated values of the second virial coefficient,  $b$ , for individual (undissociated) molecules commonly occurring as explosion products are given in Table 1. But usually the products of explosion are a complex of molecules, for which it is generally considered that the linear summation of the molar coefficients does not lead to excessive error for practical purposes, so that  $b$  for the gaseous complex is defined as:

$$b = \sum n_i b_i \quad \text{--- (5)}$$

where  $n_i$  is the mole fraction of the  $i$ -th molecular species, whose coefficient is  $b_i$ .

**Table 1**  
High-temperature second virial coefficients  
of gaseous products of explosion

Gas	$b$ (ml/mole)	Gas	$b$ (ml/mole)
Ammonia	15.2	Methane	37.0
Carbon dioxide (rotating)	63.0	Nitric oxide	21.2
Carbon dioxide (non-rotating)	37.0	Nitrogen	34.0
Carbon monoxide	33.0	Nitrous oxide	63.9
Hydrogen	14.0	Oxygen	30.4
		Water	7.9

12. During the 1939-45 War, Kistiakowsky and Wilson developed an equation of state, since widely used, which made allowance for the compressibility of molecules of the product gases. The equation is:

$$p = nRT\rho (1 - x e^{\beta x}) \quad \text{--- (6)}$$

where

$$x = b\rho kT^{-a} \text{ (} b \text{ is a constant that is obtained by guesswork)}$$

$$\beta = 0.3$$

$$a = 0.25$$

and  $k$  is usually unity

13. If in equation 6,  $\beta$  is given the value 0.625,  $k$  is unity and  $a$  is zero, the equation is identical with the Boltzmann equation to the third series term. If  $\beta$  is given the value 0.625 and  $a$  a value between 0.25 and 0.5, equation 6 is that which would be deduced for 'soft' molecules of high compressibility. But, in fact, application of the generalized equation (6) to experimental results shows that  $\beta$  cannot have a value of 0.625, and the values of  $\beta$  and  $a$  assigned above give a form which has proved an optimum 'fit', and on the basis of which a number of computer programmes (RUBYCODE, STRETCH BKW, TIGERCODE) have been worked out for the calculation of velocity, pressure and temperature of detonation, for example, from deduced formulae such as equation 7 and 8.

$$D = 2(\zeta^2 - 1)Q \quad \text{--- (7)}$$

where  $D$  is the velocity of detonation

$\zeta$  is the slope of  $p, V$  curve at detonation point (and therefore dependent on the chosen equation of state)

$Q$  is the heat of explosion (see para. 15)

$$p = 15.58 \phi \rho_m^2 \quad (8)$$

where  $p$  is the pressure of detonation (kilobars)\*

$$\phi = NM^3Q^3$$

$N$  is the number of moles of gaseous products per g of explosive

$M$  is the average molecular weight of products

$\rho_m$  is the loading density of explosive

### Thermochemistry of explosion

14. As implied in para. 9, the hydrodynamic theory of detonation requires for its development and application a knowledge of the thermochemistry of the products of explosion. It is essential to be able to measure or calculate the heat of explosion of an explosive substance, the amount and nature of the gaseous products, the temperature of explosion and the pressure attained.

#### Heat of explosion

15. There is an extensive accumulation of thermochemical data in the literature from which heats of explosion may be calculated using normal procedures, of which the best-known generalization is Hess' law: 'If a reaction is performed in stages the algebraic sum of the amounts of heat evolved in the separate stages is equal to the total evolution of heat when the reaction occurs directly'. Thus, the calculation of the heat of explosion is possible if the constitution of the products of explosion in the final equilibrium state is known, together with the heats of formation of the initial explosive and the products. The initial state of the system is taken as the physical state of the explosive at 0°C, and for most calculations the final state of the system is the state of thermodynamic equilibrium attained by the explosion products in the volume initially occupied by the explosive, with the assumption that no energy is dissipated outside the system.

16. If it is desired to measure the heat of explosion, this is done without an oxygen atmosphere in a calorimetric bomb specially designed to withstand the high pressure developed. At the same time the gases can be analysed at ordinary temperature and the total gas volume and the volume of the permanent gases produced (that is, principally those remaining after condensation of water) can be measured. Note that the nitrogen in an explosive is found almost entirely in the elemental form in the explosion products.

#### Temperature of explosion

17.  $t$ , the temperature of explosion, is defined by

$$Q(t) = \sum_i n_i \int_0^t C(t)_i dt + \sum_i n_i L_i \quad (9)$$

where  $Q(t)$  is the heat of explosion at constant volume and at 0°C, and  $C(t)_i$  is the heat capacity at constant volume,  $L_i$  the latent heat and  $n_i$  the number of molecules of the  $i$ -th explosion product. Experimentally,  $t$ , the temperature of explosion, is derived by applying  $Q(t)$ , the heat of explosion, to the products of explosion, using their heat capacities to find the resultant upper temperature limit.

18. The heat capacities of the common gaseous products of explosion have been computed to a high degree of accuracy by the methods of statistical mechanics applied to spectroscopic data, and are tabulated. It has been shown that up to 3000°C the effect of pressure on heat capacity is small, and the tabulated values for temperatures up to 5000°C may be used to compute the internal energies of the gaseous products of explosion.

19. If there are non-gaseous products of explosion (for example, alumina from aluminized explosives), approximate internal energies have been computed and tabulated, and it is considered that they are accurate enough for most purposes.

#### Effect of oxygen balance

20. If, in the hypothetical explosive  $C_xH_yO_zN_w$ ,  $z = 2x + \frac{1}{2}y$  (that is, there is just enough oxygen for the complete oxidation of the carbon to  $CO_2$  and of the hydrogen to water), the explosive is said to be 'balanced'; if  $Z$  has a smaller value the explosive is 'oxygen-deficient', and if a higher value the explosive is 'over-balanced' — as occurs with nitroglycerine,  $C_3H_5O_9N_3$ . Many explosives are oxygen-deficient (TNT,  $C_7H_5O_6N_3$ , is a notable example) and their explosion products may contain carbon monoxide and hydrogen, the distribution of which will be controlled by the water-gas equilibrium:



\* This pressure is sometimes written  $P_{c,d}$  to distinguish it from the (much lower) explosion pressure,  $P_E$ .

the thermodynamic equilibrium constant for which is defined by:

$$K = \frac{P_{H_2O} P_{CO}}{P_{H_2} P_{CO_2}} \quad \text{--- (11)}$$

where  $P_{H_2O}$ , etc., are the partial pressures of water, etc.; such equilibrium constants have been calculated and tabulated for temperatures up to 5000°C on the assumption that each constituent can be regarded as an ideal gas. But, if the equation of state of the constituents takes the form of equation (4), it can be shown that  $K$  must be multiplied by a correction factor,  $G$ , to allow for the effect of gas imperfection, and that  $G$  is defined by

$$\log_{10} G = 4.38 \frac{n}{b} (\sigma - 1) \quad \text{--- (12)}$$

where  $\sigma$  is the expression in brackets in equation (4), and  $b$  for  $CO_2$  is taken as 37.0 ml/mole.

21. The gaseous products of explosion, as controlled by the water-gas reaction, may be readily calculated. Let  $C$ ,  $H$  and  $O$  be the number of gramme atoms of carbon, hydrogen and oxygen in a given weight of explosive, and let  $(CO_2)$ ,  $(CO)$ ,  $(H_2)$  and  $(H_2O)$  be the number of gramme molecules (moles) of carbon dioxide, carbon monoxide, hydrogen and water in the (same weight of) gaseous products of explosion. From a material balance:

$$\left. \begin{aligned} (CO) &= C - (CO_2) \\ (H_2) &= \frac{1}{2}H - O + (CO_2) + C \\ (H_2O) &= O - (CO_2) - C \end{aligned} \right\} \quad \text{--- (13)}$$

Thus equation (11) becomes a quadratic in  $(CO_2)$ , of which the roots are:

$$(CO_2) = \frac{-b \pm (b^2 - 4ac)^{1/2}}{2a} \quad \text{--- (14)}$$

where

$$\left. \begin{aligned} a &= GK - 1 \\ b &= GK (\frac{1}{2}H - O + C) + O \\ c &= C(C - O) \end{aligned} \right\} \quad \text{--- (15)}$$

whence  $(CO_2)$ ,  $(CO)$ ,  $(H_2)$  and  $(H_2O)$  may be calculated.

22. Dissociation of most of the gases in the products of combustion is small at temperatures of the order of 3000°C and is, anyhow, suppressed by the high pressures of detonation; to a first approximation it may be neglected, as may the presence of methane and ammonia.

23. Thus the gaseous products of explosion of a reasonably balanced explosive may be considered to consist only of carbon dioxide, water and nitrogen, whilst a moderately oxygen-deficient explosive will give some carbon monoxide and hydrogen also. But if the explosive is markedly oxygen-deficient some carbon will also be present, resulting from the reaction



or from the direct decomposition of carbon monoxide and methane to yield carbon, oxygen and hydrogen, and a specialized thermodynamic analysis is then necessary, involving iterations to calculate the temperature and pressure of explosion.

24. As has been said, the heat of complete combustion of an explosive can be calculated, and for an oxygen-balanced or over-balanced substance this heat represents the heat of explosion. But for an oxygen-deficient explosive the calculated heat of complete combustion must be corrected on account of the heat required to oxidize (at constant volume and 0°C) carbon monoxide to carbon dioxide and hydrogen to (liquid) water:



Note that the fact that these two heats of combustion are so nearly the same is a fortunate coincidence in regard to the water-gas equilibrium.

25. So for each mole of oxygen deficiency it is necessary to deduct 135 kilocalories from the heat of complete combustion to arrive at the heat of explosion. It is convenient to express the heat of explosion at constant volume on the assumption that the water is in the liquid state, and the relationship between this  $Q_v(\text{W.L.})$  and  $Q_v(\text{W.G.})$  when the water is gaseous is

$$Q_v(\text{W.G.}) = Q_v(\text{W.L.}) - 10.23n_{\text{H}_2\text{O}} \quad \text{----- (18)}$$

where  $n_{\text{H}_2\text{O}}$  is the number of moles of water formed.

*Thermochemical pressure*

26. The theoretical thermochemical pressure,  $P_\epsilon$ , of explosion for a charge of 100g of explosive of loading density  $\Delta$  g/ml can be deduced from the expression

$$P_\epsilon = 0.821 \frac{nT\Delta}{1 - \alpha\Delta/100} \alpha(x) \text{ atm} \quad \text{----- (19)}$$

where

$$x = \frac{b}{100/\Delta - \alpha} \quad \text{----- (20)}$$

$$\alpha(x) = 1 - x + 0.625x^2 + 0.287x^3 + 0.193x^4 \quad \text{----- (21)}$$

and  $T^\circ\text{K}$  is the temperature of the products,  $n$  the number of moles of gas produced and  $\alpha$  the volume occupied by non-gaseous products;  $b$  is the virial coefficient as defined in equation (5), so that  $x$  is a virial coefficient corrected for the non-gaseous products and is so employed in the equation of state (4). The value of  $\alpha$  for alumina is 25.5 ml/mole.\*

*Summary of important thermochemical properties*

27. The important thermochemical properties of an explosive are, then:

- (1) the explosion products, in moles per unit weight
- (2) the oxygen balance, in moles per unit weight
- (3) the heat of explosion — at constant volume and with water gaseous — in kilocalories per unit weight
- (4) the volume of the gaseous products, in litres per unit weight
- (5) the explosion temperature ( $^\circ\text{K}$ )
- (6) the explosion (thermochemical) pressure, in atmospheres.

It has been shown in outline, how these can be calculated (with some approach to accuracy) or measured. Some values given by Taylor ('Detonation in Condensed Explosives' — see Bibliography) are reproduced in Table 2.

*Simple applications of thermochemistry*

28. It will be of some interest to consider one or two simple applications of thermochemistry. The heat of formation,  $Q_f$ , of a compound from its elements (which are assumed to have zero heats of formation themselves) invariably involves an energy change. If heat is liberated the compound is said to have a positive heat of formation, while if heat must be applied to cause the combination of the elements,  $Q_f$  is negative. As has been said, values of  $Q_f$  have been tabulated for many compounds and will be found in the standard reference books. In many instances it is difficult to form compounds directly from their elements, so that their heats of formation cannot be measured by direct calorimetry and indirect methods must be employed. Many such compounds can be burnt (that is oxidized) and their heats of combustion,  $Q_c$ , can be measured, enabling heats of formation to be obtained. An example is:



Hence the heat of formation of carbon monoxide is  $94 - 68 = 26$  kcal per mole. The direct combustion of hydrogen gives the heat of formation of water



\* The calculation of the thermochemical properties of metallized explosives is very difficult because there is no certainty as to order of priority of reactions among the products of explosion or as to a relevant equation of state.

**Table 2**  
**Thermochemical properties of single explosive compounds**

	<b>Formula</b>	<b>Loading density (g/ml)</b>	<b>Oxygen balance (g oxygen/100g explosive)</b>	<b>Heat of* explosion (kcal/100g)</b>	<b>Gas volume (litres/100g at STP)</b>	<b>Explosion temperature (°C)</b>	<b>Thermochemical pressure (atm)</b>
<b>Erythritol tetranitrate</b>	$C_4 H_6 O_{12} N_4$	1.50	+ 5.3	154.7	70.5	4565	$8.15 \times 10^4$
<b>Mannitol hexanitrate</b>	$C_6 H_8 O_{18} N_6$	1.73	+ 7.1	151.6	69.4	4590	$12.17 \times 10^4$
<b>Nitroglycerine</b>	$C_3 H_5 O_9 N_3$	1.60	+ 3.5	161.6	71.5	4645	$9.79 \times 10^4$
<b>Nitroglycol</b>	$C_2 H_4 O_6 N_2$	1.496	0.0	176.6	73.7	4830	$8.43 \times 10^4$
<b>Pentaerythritol tetranitrate</b>	$C_5 H_8 O_{18} N_4$	1.50	- 10.1	153.5	78.0	4345	$9.17 \times 10^4$
<b>Tetranitromethane</b>	$CO_2 N_4$	1.643	+ 49.0	45.6	68.6	2100	$6.89 \times 10^4$

\* With constant volume and water liquid

29. A heat of reaction between compounds is the difference between the sum of the heats of formation of the products and the sum of the heats of formation of the reactants, and this definition can be applied to give rough approximations to the heats of explosion,  $Q_p$ , of two amatols (mixtures of ammonium nitrate with TNT, see Chapter 7) as given in the following paragraphs.

30. An 80/20 amatol is an oxygen-balanced explosive which detonates according to the equation:

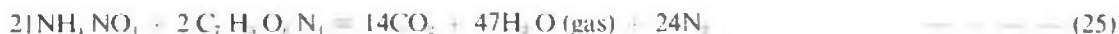

Values of  $Q_f$ , from the literature, for ammonium nitrate and TNT are respectively 88 and 16.4 kcal/mole; those for  $\text{CO}_2$  and water (gas) are 94 and 58 kcal/mole respectively. Thus the gross heat of explosion,  $Q_p$ , equals  $1316 + 2726 - (1848 + 33) = 2161$  kcal (equivalent to 1011 kcal/kg) while the gas volume is 892 litres/kg measured at 0°C and one atmosphere.

31. 60/40 amatol has the molecular composition:

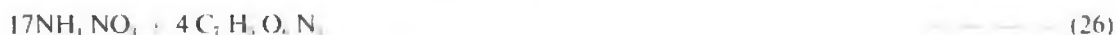

As it is oxygen-deficient (there is only 25% of the oxygen required for complete combustion of the carbon and hydrogen) the reaction products will contain carbon monoxide and hydrogen, and the evaluation of the distribution of the oxygen among the products will call for the application of the water-gas equilibrium (see equation 10), for which the value of  $K$  has been found to be about 7 at the explosion temperature of the composition. It then appears that the molecular composition of the products of explosion is



whence the gross  $Q_p$  is 2002 kcal, equivalent to 884 kcal/kg with a gas volume of 858 litres/kg. Thus it is seen that the oxygen deficiency of the 60/40 as compared with 80/20 amatol results in a decrease of both heat of explosion and gas volume on a weight basis, and therefore a decreased explosive 'power'.

32. A procedure similar to the foregoing can, of course, be applied to propellants, first calculating their empirical molecular composition per unit of weight. Their burning temperatures are often better known than are the temperatures of explosion of explosives, which are very sensitive to the assumed equation of state.

33. Obviously, in the calculation of heats of explosion much depends on the products to be expected. Kistiakowsky and Wilson attacked the problem of the products of explosion of the compound  $\text{C}_x\text{H}_y\text{O}_z\text{N}_w$  by using thermodynamic and statistical mechanical methods applied to the available kinetic equilibrium data, and they deduced rules to give the likely composition of the explosion products 'at a time after detonation after most of the external work has been done but while the gases are still hot' and under given physical conditions of the system. The K-W rules are as follows:

(1) *Permissible Products* Only the following molecules (and no free atoms) can appear in the explosion products:

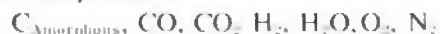

(2) *Distribution of Oxygen*

- the C is first oxidized to CO
- any residual oxygen then oxidizes the H to  $\text{H}_2\text{O}$
- any residual oxygen then oxidizes the CO to  $\text{CO}_2$
- any residual oxygen then separates as  $\text{O}_2$

34. The rule in sub-para 2(a) follows from a consideration of the equilibrium



which at the temperature of detonation (3000°C–4000°K) lies far over to the right, despite the adverse effect of the high pressure obtaining under detonation conditions. Sub-para 2(b) is based on the data for the water-gas equilibrium



which also lies far over to the right under detonation conditions.

35. The K-W rule of para. 33 sub-para (1) is broadly borne out by the results of analysis of the products of detonation of picric acid, TNT and tetryl, although small amounts of ammonia and methane (and sometimes ethylene and hydrogen cyanide) also appear. But the application of both rules to those three systems yields results which correspond with the composition of the observed final products only as the density of the charge and its degree of confinement decrease.

36. Springall and Roberts examined the effect of variation of charge density and confinement on the relative rates of change of pressure and temperature from the instant of detonation and deduced three additional 'S-R' rules:

(1) if in the hypothetical formula given in para. 33,  $z$  is equal to or less than  $x$ , let

(a)  $\frac{1}{3}$  of the 'K-W' CO be regarded as decomposing according to the equation:



and (b)  $\frac{1}{6}$  of the 'K-W' CO be regarded as being reduced according to the equation:

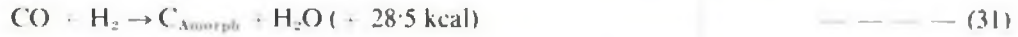

(2) if  $x$  is less than  $z$ , and  $z$  is less than  $x + \frac{1}{2}y$ , then let only the process in sub para 1(a) occur

(3) if  $z$  is greater than  $x + \frac{1}{2}y$ , then let there be no modification to the 'K-W' products.

37. The application of the 'S-R' rules to the experimental systems gives encouraging agreement with the observed results using charges of density 1.3 to 1.7 g/ml in strong steel tubes (1 in. internal diameter,  $\frac{1}{4}$  in. walls), bearing in mind the changes which have occurred between 'a time shortly after detonation' and the time when the products of explosion can be analysed.

38. It has been found that the application of the K-W and S-R rules may be clarified by considering the pressure and temperature conditions in systems in which explosives are detonated unconfined or confined. These conditions are shown 'typically' with respect to time in fig. 1 (a) and (b), where  $T_c$  is the temperature at which the chemical equilibrium in the reaction products 'freezes'.

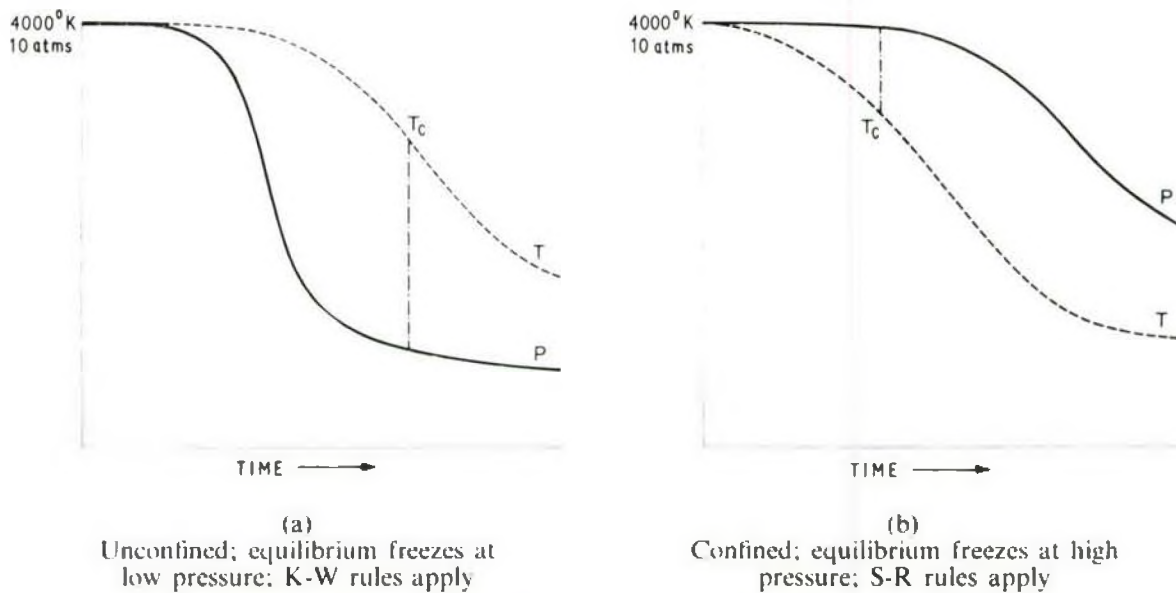

Fig. 1 Application of K-W and S-R rules to unconfined and confined explosions

The application of this concept to the detonation of charges of tetryl unconfined (A) and confined in a mild steel cylinder (B) led to the following results:

	Detonation Products (mols/mol Tetryl)						$Q_p$ (cal/g)
	C	CO	CO <sub>2</sub>	H <sub>2</sub>	H <sub>2</sub> O	N <sub>2</sub>	
(A)							
Experimental	0.2	6.2	0.6	1.8	0.7	2.5	904
Calc. by K-W rules	0	7.0	0	1.5	1.0	2.5	871
(B)							
Experimental	1.4	4.6	1.0	1.3	1.0	2.5	1035
Calc. by S-R rules	1.2	4.6	1.2	1.5	1.0	2.5	1020

Hydrodynamic theory of detonation

The employment of Rankine-Hugoniot relations

39. The comparative insensitivity of the velocity of the detonation wave (as measured in an explosive, see para. 62-64) to changing experimental conditions was soon noticed, and it prompted attempts to explain the phenomenon. The Rankine-Hugoniot relation between the pressure,  $p$ , and specific volume,  $v$ , behind the detonating front and the corresponding quantities in the solid explosive is illustrated in the following figure 2.

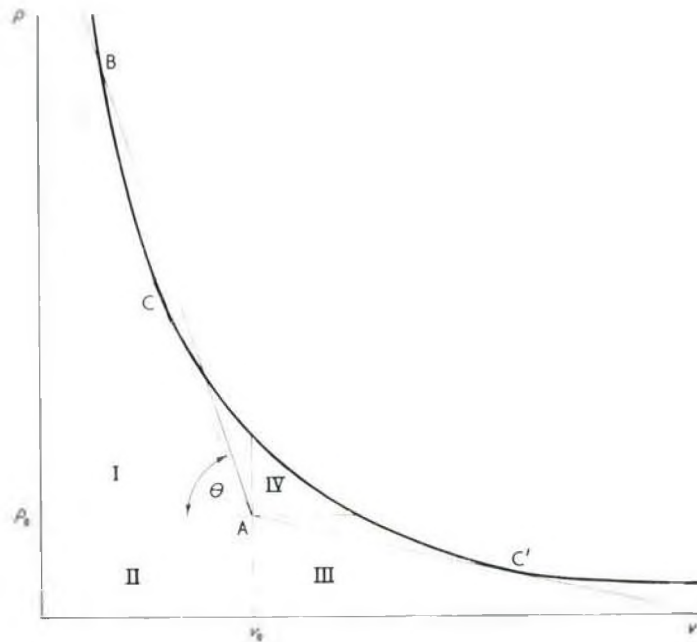

Fig. 2 Rankine-Hugoniot curve for completely reacted explosive ( $n = 1$ )

40. The curve is the uppermost one of a family of 'parallel' curves which can be drawn for values of  $n$  (the fraction of reaction in the zone behind the detonation front) between 0 and 1; their precise form will depend on the chosen equation of state employed — although such curves can be drawn from experimental data. The point A, with co-ordinates  $p_0, v_0$  and situated on the curve for  $n$  equals 0, represents the solid state conditions in the explosive just ahead of the front. It may be shown on hydrodynamic grounds that the velocity of the detonation wave is proportional to the square root of the slope of the line AB, where B is a point representing the gaseous-state conditions. (This is expressed as

$$\frac{D}{\mu} = \mu = (\tan \theta)^{\frac{1}{2}} \tag{32}$$

where  $D$  is the velocity of detonation and  $\mu$  is the mass velocity of detonation). But it has been found experimentally that the velocity of the detonation wave of an actual solid explosive corresponds to the slope of the tangent AC to the curve, the point C representing the conditions after complete reaction. This result, that the velocity of the detonation wave is proportional to the square root of the slope of the tangent line AC, is known as the Chapman-Jouget (C-J) condition, and the assumption that the observed value  $\theta$  is the lower limit for this angle is the C-J hypothesis. The angle  $\theta$  must be in quadrants I or III, since  $\tan \theta$  in the other quadrants would be negative and  $(\tan \theta)^{\frac{1}{2}}$ , and therefore  $D$ , would have an imaginary value. All points on the curve in quadrant III have values of pressure less than  $p_0$  and of volume greater than  $v_0$ , and corresponds to 'deflagration' (or burning) rather than 'detonation'; C is probably the lower limit of stable deflagration.

41. It can easily be shown that a condition of the reaction products represented by a point such as B, higher along the curve than C, would be unstable, because above the point of tangency the velocity of sound in the reacted material is greater than that of the detonation wave so that any rarefaction region behind the wave front would eventually catch up with it and 'eat its head off'. (Such a rarefaction could arise because after a while, at a point some distance behind the detonation front, the burnt gases must begin to lose pressure and density.) Points above the point of tangency being thus excluded, arguments—mostly on thermodynamic grounds—have been advanced to show that points on the curve below the

point of tangency are also excluded, but these arguments have not been very convincing. However, it is possible to appreciate that they may be excluded by a consideration of the 'parallel' curve for  $n = 0$ , which passes through the point A. The upward extension of the tangent line AC will intersect this curve at a point corresponding to a high pressure and a high density. Thus we have on the curve  $n = 0$  (no reaction) a point A at which the explosive is undisturbed and an upper point (separated from it by a discontinuity (the 'shock wave'), at which explosive matter is physically, but not chemically, changed.\* Now it is intuitively evident that in such a shock wave the region of high pressure and density will invade and consume the region of low pressure and density; thus in a non-reactive system the shock dies out—but in a reactive system it is supported by the energy released by the reacting explosive. (The intuitive assertion that in a shock wave the high pressure/high density region invades the low pressure/low density region has been proved by thermodynamic methods.) Transferring this line of reasoning to the curve for  $n = 1$ , it would appear that points on the curve below point C would be excluded in a detonation-wave system.

42. It was remarked that there is a discontinuity between point A ( $p_0, v_0$ ) and the upper point of intersection ( $p', v'$ ) of the tangent line AC with the R-H curve for  $n = 0$ , and it may be of some interest to consider the state of matter in the region of this discontinuity or 'shock' wave. Just ahead of it the matter is at rest, but as the detonation engulfs it (that is, as the shock wave advances into it) forces begin to operate to set it in motion with a velocity  $W$  which may be expected to be in the direction of the detonation wave, the velocity of which is  $D$ .  $W$  will be less than  $D$ , since the detonation front is engulfing new material at each moment, so that the material which has crossed it must be falling behind. It can be shown that

$$W = [(v_0 - v') (p' - p_0)]^{1/2} \quad (33)$$

(Note the dependence of  $W$  on  $v_0$ ; that is, on the original density of the explosive.)

43. In an explosive such as TNT,  $W$  is of the order of 1500m/sec, whereas  $D$  is 6900m/sec at a density of 1.57g/ml. So then, von Neumann suggests that the explosive receives a vehement mechanical blow when it gets in contact with the reaction front. This blow is delivered by the discontinuous increase of velocity in the matter immediately behind the reaction front. This is smaller than the detonation velocity,  $D$ , but is of the same order of magnitude. So the blow is of the same qualitative character as that dealt by the detonation of a primer, and since the latter suffices to start the detonation it is plausible that the former should be suited to propagate it.

#### Outline of hydrodynamic detonation theory

44. Having given in the foregoing paragraphs a qualitative approach to the theory of detonation, this Section—which is independent and may be omitted by those who do not wish to immerse themselves in its detail—will be devoted to an outline of the hydrodynamic theory as stated by Taylor in 'Detonation in Condensed Explosives' (see Bibliography).

45. At the end of para. 9 it was remarked that in a detonating explosive there are five 'unknowns' to be evaluated—the detonation pressure and temperature, the specific volume (that is, inverse density) of the products, the velocity of the detonation wave and the streaming (or translational) velocity of the reaction products behind that wave. Clearly, then, five simultaneous equations will be required to determine these unknowns, (although, as has been seen in para. 14 *et seq.*, some approximate ideas of the magnitude of the first three can be obtained by other means). The application of the laws of conservation of mass, energy and momentum will provide three of these; a fourth is provided by the modified Boltzmann equation of state (equation (4)), and a fifth may be deduced from the principle that a shock wave passes through a gas with a velocity equal to the sum of the translational velocity of the gas plus the velocity of sound in the gas at its final temperature and density (Note the correction of Dixon's hypothesis, see para. 3, arising ultimately from Schuster's note to Dixon's paper).

46. Suppose a plane detonation wave to have been established in an explosive medium of infinite extent parallel to the plane of the wave or, alternatively, confined in a perfectly rigid tube (so that no lateral motion can occur and the flow is everywhere one-dimensional). We regard the wave as headed by a shock front,  $X_s$ , which advances with constant velocity  $D$  into the unconsumed explosive, and is followed by a zone of chemical reaction. From the standpoint of an observer accompanying it the ('stationary') wave will then appear as in Fig. 3. Undetonated explosive will seem to flow from the right into  $X_s$  with constant velocity  $u_0 = -D$ ; its pressure, temperature, specific volume and internal energy per unit mass are  $p_0, T_0, v_0$  and  $E_0$  at all points to the right of (that is, ahead of)  $X_s$ , where they change abruptly to values  $p_s, T_s, v_s$  and  $E_s$ , and thereafter continuously as reaction proceeds. If the shock front is to have constant velocity, the wave must be supposed steady between  $X_s$  and some later and parallel

\* The curve  $n = 0$  is that which Rankine and Hugoniot were examining in their work on mechanical shock in inert matter. The curve  $n = 1$  is that which Chapman and, independently, Jouget considered in their work on detonation. The region  $n = 0$  to  $n = 1$  was the subject of a mathematical analysis by G I Taylor and H Jones during the 1939-45 War.

plane  $X_1$ , that is, conditions to the right of  $X_1$  remain constant in time from the standpoint of the moving observer.

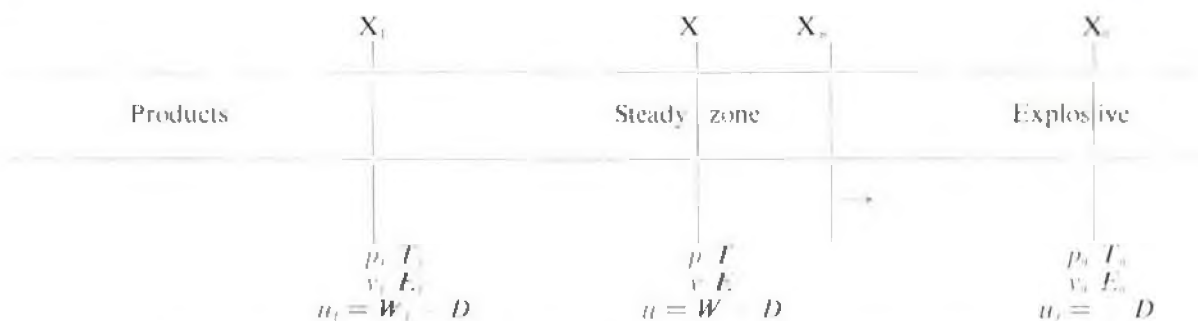

**Fig. 3** A sectional diagram of the steady detonation wave from the standpoint of an observer accompanying the wave

47. Now consider a region of flow bounded by a stream-tube of unit cross-sectional area and two planes,  $X_2$  and  $X_1$ , lying respectively in the undetonated explosive and the steady zone. Conservation of mass, momentum and energy in this region requires:

$$\frac{u}{v} = \frac{u_2}{v_2} \quad \text{----- (34)}$$

$$\frac{u^2}{v} + p = \frac{u_2^2}{v_2} + p_2 \quad \text{----- (35)}$$

$$E + \frac{1}{2}u^2 + pv = E_2 + \frac{1}{2}u_2^2 + p_2v_2 \quad \text{----- (36)}$$

Equations (35) and (36) assume that viscous and thermal transfer across  $X$  can be neglected; but such transfer need not be negligible throughout the whole region between  $X_2$  and  $X_1$ , so that the dissipative processes which must occur at  $X_2$ , in particular do not invalidate the equations. It is necessary only that the gradients of temperature and velocity should be small at  $X$  itself, as they probably are throughout the steady zone up to, but excluding,  $X_2$ . Equation (34) holds unconditionally, expressing only the conservation of mass.

48. In terms of  $p$  and  $v$  as independent variables the above equations become:

$$u_2 = -v_2 \left( \frac{p - p_2}{v_2 - v} \right)^{\frac{1}{2}} \quad \text{----- (37)}$$

$$u = -v \left( \frac{p - p_2}{v_2 - v} \right)^{\frac{1}{2}} \quad \text{----- (38)}$$

$$E - E_2 = \frac{1}{2}(p - p_2)(v_2 - v) \quad \text{----- (39)}$$

Equation (39) is one form of the Rankine-Hugoniot (R-H) equation; it replaces the relation  $dE = -p dv$  which would apply to an isentropic change, and implies that the increase in internal energy across the shock front is equal to the work done by the mean pressure during compression.

49. With reference to a co-ordinate system at rest in the unconsumed explosive, equations (37) and (38) become:

$$D = v_2 \left( \frac{p - p_2}{v_2 - v} \right)^{\frac{1}{2}} \quad \text{----- (40)}$$

$$W = (v_2 - v) \left( \frac{p - p_2}{v_2 - v} \right)^{\frac{1}{2}} \quad \text{----- (41)}$$

where  $W$  is the velocity of flow, or 'streaming velocity', in the new reference system and the positive sense of  $W$  is taken in the direction of advance of the wave. Equation (39) is invariant. Equations (39), (40) and (41) apply at any section  $X$  within the steady zone  $X_2X_1$ . The state variables  $p$ ,  $v$ ,  $E$ , together with the material velocity  $W$ , vary from section to section;  $D$ , of course, remains constant.

50. From (40) and (41), by eliminating  $v$ :

$$DW = (p - p_0) v_0 \quad \text{--- (42)}$$

and by eliminating  $p$ :

$$\frac{W}{D} = 1 - \frac{v}{v_0} \quad \text{--- (43)}$$

51. Assume now that at the plane  $X_1$  reaction is complete and chemical equilibrium is attained. Equation (39) then defines a relation between  $p_1$  and  $v_1$  which must be satisfied if the wave is to be steady; but it is insufficient alone to determine a unique wave velocity such as experiment shows to exist. So the selection of a particular end state,  $p_1 v_1$ , characteristic of a stable wave must depend on considerations other than those implied by the conservation laws, and the argument developed in para. 3 to 8 makes it clear what those considerations must be. If the detonation wave is a shock wave, initiating chemical reaction and continuously supported by the energy so released, it must be protected against the rarefaction which will always follow. This is impossible if the velocity of small disturbances behind the wave is greater than that of the wave itself; that is, if  $a_1$  is the velocity of sound at  $X_1$  relative to the fluid there, which itself has velocity  $W_1$ , then if  $a_1 + W_1 > D$  the wave cannot be steady but must lose velocity. If  $a_1 + W_1 < D$ , such a condition must persist some little way into the zone  $X_1 X_2$ , by reason of continuity (that is,  $X_1$  is not a plane of abrupt change), and the chemical energy released in that short distance can have no influence on what happens ahead of it and is therefore ineffective to support the wave front. In practice, this is equivalent to a reduction in the heat of reaction with consequent drop in wave velocity. So it appears that the highest steady-wave velocity will be realized only if  $a_1 + W_1 = D$ . This condition is known as the Chapman-Jouguet (C-J) condition, valid only at the point  $p_1 v_1$  of all those points defined by equation (39) which are possible final states.

52. So, between equations (4) or (6), (37), (38), (39) and equation (44) denoting the C-J condition

$$a + W = D \quad \text{--- (44)}$$

it is possible, by using probable values of  $a^*$ , (calculated from  $a^2 = (dp/d\rho)_s$ , where  $\rho$  = density and  $s$  = entropy) to arrive at values for the five unknowns mentioned in para. 9 and 45. But the whole theory, as outlined in the foregoing, is based on so many assumptions and simplifications that it is useful more as a means of enabling some approximation to values of  $p$ ,  $v$  and  $T$  to be arrived at from observed measurements of  $D$  than as a direct means of calculating them, or for making 'intelligent guesses' at their values for a new explosive in the light of what is known of others. But calculated values of  $D$  are often within  $\pm 5$  per cent of observed values.

53. Other theories have been developed, usually based on other equations of state, and those with adequate mathematical equipment will find a review of the subject by Evans and Ablow (Chemical Reviews, 1961, 61, 129-178).

54. Fig. 4 shows a diagrammatic representation of the Rankine-Hugoniot curve, XABY, on  $p - v$  ordinates, derived from equation (39). It will be noticed that the  $p_0 v_0$  (initial) point does not lie on the curve, as it would in the instance of a non-reactive shock wave. This is because the exothermic reaction at constant volume between  $p_0 v_0$  and point A on the curve must normally involve a rise in pressure (that is, to give a more true representation, equation (39) should have added to its right side a quantity  $Q$ , the heat of reaction of the system). The only steady-state detonation (C-J detonation) that occurs is that for which the line between the initial state,  $p_0 v_0$ , and the final state,  $p_1 v_1$ , is tangential to the R-H curve; a corresponding line from  $p_0 v_0$  in the other direction, tangential to the curve at D, relates to C-J deflagration. Between A and C the curve relates to weak detonations, between C and X to strong detonations, between B and D to weak deflagrations and between D and Y to strong deflagrations. Jouguet enunciated the following rule regarding these points and regions of the curve:

The flow relative to a steady reaction discontinuity is:

- (1) supersonic ahead of a detonation
- (2) supersonic behind a weak detonation
- (3) subsonic behind a strong detonation
- (4) sonic behind a C-J detonation
- (5) subsonic ahead of a deflagration
- (6) subsonic behind a weak deflagration
- (7) supersonic behind a strong deflagration
- (8) sonic behind a C-J deflagration.

(4) is a statement of the C-J detonation condition referred to above.

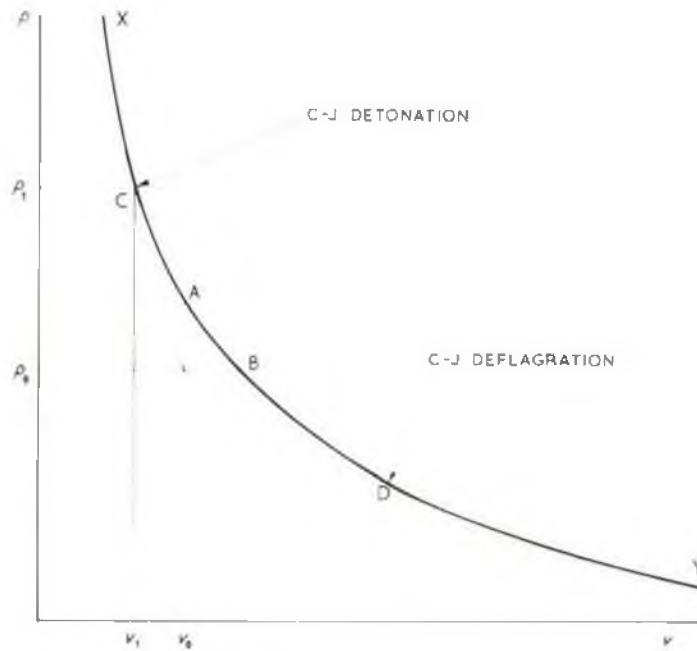

Fig. 4 Rankine-Hugoniot curve of reaction products

55. A detonation is, physically, a combustion process initiated by a shock wave. Fig. 5 is a representation of what is happening to the quantities,  $p$ ,  $v$ ,  $W$ ,  $T$  and  $F$  (the fraction of reaction completed) within the steady zone of that wave. The pressure and temperature rise abruptly within the thickness of the shock front (which is not the infinitely thin 'plane' of the theory), but by the end of the reaction zone (which is of the order of 10mm thick, but is smaller as the explosive is more powerful, and is only about 3mm for finely powdered TNT and 0.4mm for nitroglycerine)  $p$  has decreased to a half of  $P_{max}$ , whereas  $T$  has doubled.

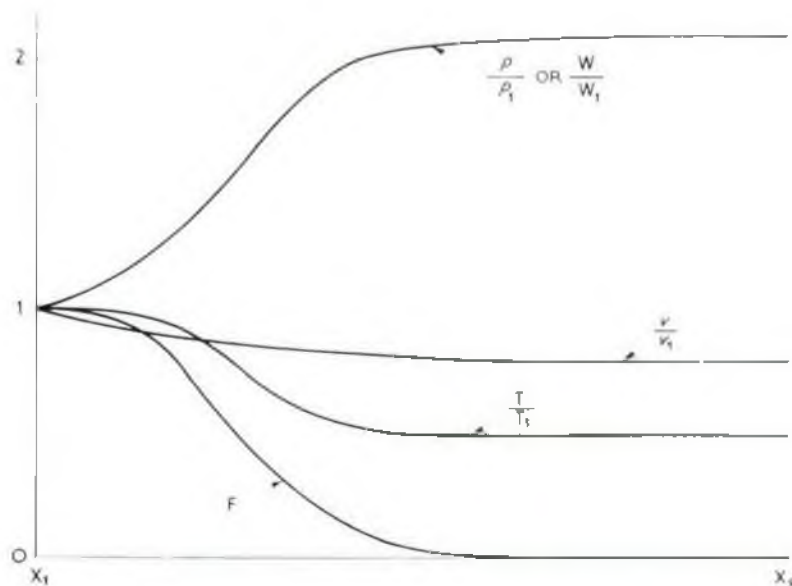

Fig. 5 Reaction-wave, steady-zone conditions

### Properties of explosives

#### Factors controlling initiation of detonation

56. The preceding theory is based on the assumption, among others, of perfect confinement of the explosive. This, of course, does not happen in practice. Quantities of explosive are of definitely limited extent and containers have a 'yield point', and it soon became clear that the velocity of detonation (V of D) of a detonating explosive was not a constant, characteristic of the particular explosive, but depended

on the diameter of the charge and the nature of its envelope; it also depended on the density of the particular explosive as employed in a charge. In fact, for a given explosive the  $V$  of  $D$  tended to a maximum as each of the quantities, charge density, charge diameter and degree of confinement increased. Moreover, there is a diameter below which self-sustained propagation is not possible; this diameter depends on the physical as well as the chemical nature of the explosive, but in general those of the highest energy content detonate in the smallest diameters. It is possible with some liquid explosives to prevent propagation in pipe lines by inserting in the line an 'explosion trap' consisting of a nest of small-bore pipes of total cross-sectional area equal to that of the main pipe.

57. Some liquid explosives (for example, nitroglycerine), and gelatinous explosives based on nitroglycerine, and, under suitable circumstances, some solid explosives such as TNT and tetryl, are capable of detonating at either high or low velocity according to the method of initiation employed. In such cases the  $V$  of  $D$ /diameter relation is not continuous; either high or low velocities are possible, and there is a discontinuity between the high- and low-velocity regimes, intermediate stable velocities not being observed. It appears that the low-velocity regime involves only partial reaction of the explosive (a view supported by the fact that unreacted material can frequently be detected after the explosion) but the reasons for this are not understood; all that can be said is that a sufficiently powerful initiatory impulse will lead to high  $V$  of  $D$ . If a blasting gelatine free from air inclusions is initiated by a weak detonator it tends to fail in propagation; but if such a gelatine is made with many small air bubbles—so that it has a 'creamy' appearance—it will tend to detonate at, or pick up to, high velocity, and if a well-aerated gelatine is kept until the fine bubbles coalesce it becomes increasingly insensitive. Again, it has been shown that certain solid explosives in granular form are initiated by shock waves having a peak pressure pulse of 1 to 3 kilobars, but if in cast or well-pressed form (and thus air free) the explosives require peak pressure pulses some two orders of magnitude higher. A 2-kilobar shock will raise the temperature of a solid only a few degrees, but that of air by several hundred degrees.

58. The effect of air inclusions in liquid explosives was studied by Bowden during the 1939-45 War when, in a series of elegant experiments, he showed that much less energy was required to initiate a drop of nitroglycerine if it was struck with a concave-ended striker than if a flat-ended one was employed. This was attributed to the heat development by the adiabatic compression of the air in the cavity of the striker, giving rise to a 'hot spot' in the NG whence explosive decomposition proceeded.

59. This 'hot spot' theory of initiation has received a great deal of attention, although it is doubtful whether it is more than one explanation of how detonation is initiated, though often an important one. The various experiments described above show that a detonation wave can be initiated by a shock of velocity and pressure less than those in a detonation shock front. The minimum effective shock is that which, somehow, creates a temperature capable of initiating reaction before the temperature has time to fall again, and which is thus defined by both its strength and duration. It is a measure of the 'detonation sensitiveness' of an explosive; those explosives are the more sensitive which react the more rapidly at the temperature created by the shock.

60. It is common experience that a factor affecting sensitiveness to percussion or friction is the presence of grit in the explosive. Using the Rotter impact test, Ubbelohde showed that sensitization by grit was not significant unless the hardness of the grit exceeded 4 Moh, above which value the sensitizing effect increased to some extent with hardness as well as with the proportion and particle size of the grit. Using grits at the low end of Moh's scale of hardness, Bowden showed that while sensitization had little relation to hardness it was sharply dependent on the melting point of the grit—grits melting above 430°C were effective, and those melting below 400°C were ineffective. Bowden concluded that, in general, for representative liquid and solid explosives, frictional ignition is caused by the formation of 'hot spots' of minimal temperatures between 400°C and 500°C.

#### Values of explosive parameters

61. From all that has been said in the preceding paragraphs of this Chapter it will be apparent that it will be useful if absolute or, at least, relative values can be obtained for the following properties of an explosive:

- (1) velocity of detonation
- (2) calorimetric value—that is, available chemical energy
- (3) 'power' or 'strength'—that is, useful chemical energy
- (4) volume and nature of products of explosion (this, combined with sub-para. 2 enables an assessment to be made of the temperature of explosion)
- (5) pressure of explosion.

Brief descriptions follow of the methods employed to study these properties.

#### *Velocity of detonation*

62. Velocity of detonation is determined by either of two basic methods, one recording the arrival of detonation at two or more conveniently spaced points in a column of the explosive and the other

providing a continuous record of the progress with time of the detonation wave, usually along the surface of a column of the explosive.

63. It was remarked in para. 3 that Berthelot and Le Chatelier had made measurements of the velocity of detonation in gaseous systems, and that the former had employed similar methods with solid explosives. Fine wires were threaded through a long explosive charge at various points of known distances apart and their rupture as the detonation wave passed them was recorded by a Mettegang spark chronograph (Fig. 6). The low order of sensitiveness of the chronograph necessitated the use of long charges, but the method can today be employed with much shorter charges, using electronic timers. However, in 1906 Dautriche devised a non-electric self-timing method (Fig. 7) which could be used with reasonably short charges (ca 150mm). About half-way along the charge from the end to which the detonator was to be applied he inserted one end of a loop of detonating fuze (see Chapter 7) and at a measured distance,  $l_1$ , further along he inserted the other end of the fuze. He laid the loop of fuze on a strip of lead so that its centre point coincided with an engraved reference mark near one end of the strip. On firing the charge the two ends of the fuze were initiated as the detonation wave passed them, but with a time interval corresponding with the time taken by the wave to cover the distance  $l_1$ . When the two detonation waves in the fuze met they left a mark on the lead strip at a distance  $l_2$  from the reference mark. If the V of D of the fuze is  $d$  that,  $D$ , of the explosive is given by

$$D = \frac{dl_1}{2l_2} \quad (45)$$

The Dautriche method is still widely used for routine measurements.

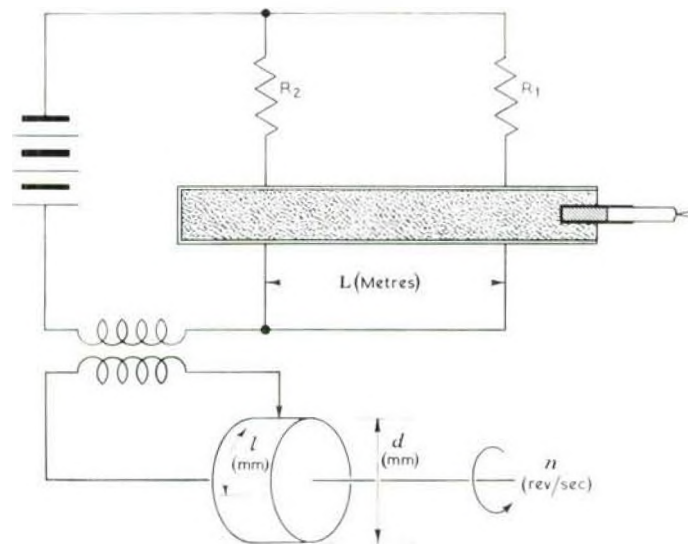

Fig. 6 Diagram of Mettegang apparatus

64. The 'continuous record' method (para 62) is, of course, a photographic one. Briefly, an image of the explosive (which may be a stick of thickness about 10mm and length about 50mm) is focussed on a high-speed rotating mirror at the centre of a circular segment of photographic film; the image is thus swept across the film at a known rate. 'Writing speeds' of several thousand metres per second can be achieved with such 'streak' cameras. It is also possible, using a similar camera having a specially optical system, to view the detonation as a series of 'frames', and commercial high-speed cameras are available which will give 25 frames on 35mm film at rates of 1 to 4 million frames per second, using an air-driven mirror turbine for the lower rate and a helium-driven one for the higher rate; such 'framing' cameras are useful for the study of detail in part of the detonation.

65. It may be remarked that an empirical formula for calculating the V of D which was developed during the 1939-45 War, is:

$$D = 430 \left[ \frac{nT}{M} \right]^{1/2} - 3500 (\delta - T) \quad (46)$$

where

- $D$  is the V of D in metres per second
- $n$  is the number of molecules of gas produced per molecule of explosive
- $T$  is the detonation temperature (degrees Kelvin)
- $M$  is the molecular weight of the explosive
- $\delta$  is the density of explosive (g/ml)

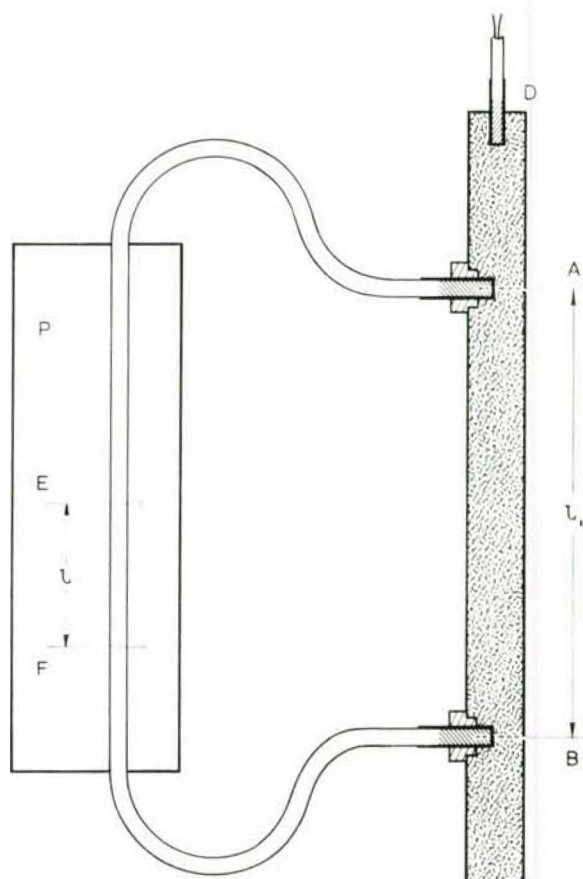

Fig. 7 Diagram of Dautriche apparatus

#### Calorimetric value of explosive

66. The calorimetric value of an explosive is determined in a "bomb calorimeter", an equipment very similar to that used in measuring the calorific value of a fuel. The principal differences in the equipment are that the bomb is larger and stronger for an explosive, and that an atmosphere of oxygen is not used to ensure combustion (because the explosive contains its own oxygen). The bomb, however, is placed in a thermally insulated water-filled calorimeter, as with calorific value measurements. The heat evolved per gramme of explosive varies slightly with the density of loading; this variation is due to the final composition of the gases of explosion being dependent on the pressure when they reach equilibrium. The determinations are made at normal temperature, so the water formed condenses, yielding up its latent heat of vaporization and thus giving a higher value than corresponds to the ordinary conditions of application of the explosive; the calorimetric value so obtained is therefore described as 'Water Liquid' (WL). The value in the 'Water Gaseous' (WG) state can readily be calculated from an estimation of the water formed (the latent heat of vaporization of water is 10.52 kcal per gramme mole at 25°C).

#### Power of explosive

67. The 'power' of an explosive is measured by determining the work which it will do when detonated. An early method of obtaining relative values of 'power' is due to Trauzl and is still employed to some extent. A known weight (usually 20g) of the explosive is placed, with a detonator, in a test-tube-shaped cavity in a standard lead block and the aperture of the cavity closed with a standard tamping of dry sand. The expansion of the cavity after explosion is measured (by pouring in water from a graduated vessel) and is compared with the expansion given by the same weight of picric acid. The standard lead block is 200mm diameter and 200mm high and the axial cavity is 25mm diameter and 125mm deep; a good deal of care must be taken to control the purity of the lead and its rate of cooling on casting. The method gives misleadingly low results for slow-burning explosives, for example, gunpowder.

68. Another comparative method is the 'pendulum' test: it was used in this country for some 50 years until 1949 in the testing of certain mining explosives. A standard weight of explosive was placed in a steel 'cannon' tamped with china clay and fired into a suspended mortar, the maximum swing of which was compared with that produced by the standard explosive.

69. A more modern method is that of the Ballistic Mortar test, which is usually used to give comparative results but can give results in absolute units. The ballistic mortar is an instrument of some precision and gives, to a first approximation, a measure of the useful chemical energy released by an explosive. A standard weight of explosive is fired in a suspended mortar closed with a tightly fitting steel projectile and the angle of recoil of the mortar is measured.

70. The heats of explosion, lead block expansions and ballistic mortar recoil energies of a group of explosives will be found to be of similar order and in general agreement, but there is not usually exact correlation owing to differences in after-burning of some of the products of explosion or, with the lead-block test, the relatively light confinement.

71. An approximate measure of the 'power' of an explosive may be obtained by comparing its 'characteristic product', the product of the heat of explosion (cal/g) and the volume (ml/g) of the gaseous products of explosion, with that of picric acid. For RDX the heat is 1355 cal/g and the volume 855 ml/g, and for picric acid 895 cal/g and 780 ml/g, and so the power of RDX is approximately 1.66 times that of picric acid.

72. At this point it may be remarked that a knowledge of both the power and the V of D of an explosive is useful in assessing its likely performance in a military store. The combination of the two properties is a measure of the 'brisance' of the explosive, a high value of which is desirable if sheer destruction is required but a lower value of which is called for if a shell, bomb or grenade is required to burst to give lethal fragments, which should not be too small. The Americans assess brisance by the crushing effect on 80g of a standard sand of 0.40g of explosive contained in a blasting-cap shell.

#### *Volume and nature of products*

73. The nature and volume of the gaseous products of explosion can be ascertained by examination of the contents of the bomb after determination of the uncorrected calorimetric value. But it must be remembered that, as such examination can be made only after the gases have cooled, some interactions among them will have occurred; for example, the following, which being exothermic, are promoted by falling temperature:



74. After analysis of the final gases and assessment of the 'after reactions' which have contributed to their composition it is possible to arrive at a view of the actual products of detonation and to correct the measured calorimetric value for heat changes due to reactions among them. From the corrected calorimetric value, and from a knowledge of the specific heats of the products of detonation and their weights, it is possible to arrive at an estimate of the detonation temperature.

#### *Pressure of explosion or detonation pressure*

75. The pressure of explosion of a slow-burning (that is, propellant) explosive is obtained from a 'closed vessel' firing (see Chapter 12). The very large (of the order of 300 kilobars) and sudden (the duration is about 5 microseconds) dynamic pressures produced by a true detonation are measured by the Hopkinson pressure bar, which is a cylindrical steel bar from one end of which a short length (the 'time piece') has been cut; the cut faces are ground 'true' so that the time piece will adhere to the main bar. A diagrammatic sketch of the apparatus is shown in Fig. 8. If an impulsive shock (for example, from a detonating explosive) is applied to the bar at the end opposite to the time piece, a compression wave will pass along the bar with the velocity of sound in steel (ca 17000 ft/sec) and will pass unaltered into the time piece, at the end of which it will be reflected as a tension wave which, on reaching the interface between time piece and bar, will cause the time piece to separate with a 'trapped' momentum which is the integral of the pressure-time wave which has passed the interface. The time piece is projected and caught in the cup of a ballistic pendulum, whence the momentum is measured. By using time pieces of differing lengths, differing proportions of the momentum of the waves can be trapped, whence the average pressure of the wave can be calculated. If the length of a time piece is  $l$  inches the time ( $t$ ) taken for the

wave to travel to and fro in it (that is, twice its length) is  $2l/12 \times 17000$  sec or approx.  $l \times 10^{-5}$  sec. If the momentum imparted to the time piece is  $W$  ft lb second units, the average force which has acted on the bar is  $W/l \times 10^{-5}$  lb. The mean value of the pressure,  $p$ , is given by

$$p = \frac{8M}{d^2 tT} \times S \quad \text{--- (51)}$$

where

$M$  is the mass of the pendulum in pounds

$S$  is the deflection of the pendulum in feet

$d$  is the diameter of the timepiece in feet

$t$  is the time taken by the pressure-pulse to traverse twice the length of the time piece, in seconds

$T$  is the time of oscillation of the pendulum in seconds

$p$  is the pressure in poundals per ft<sup>2</sup>

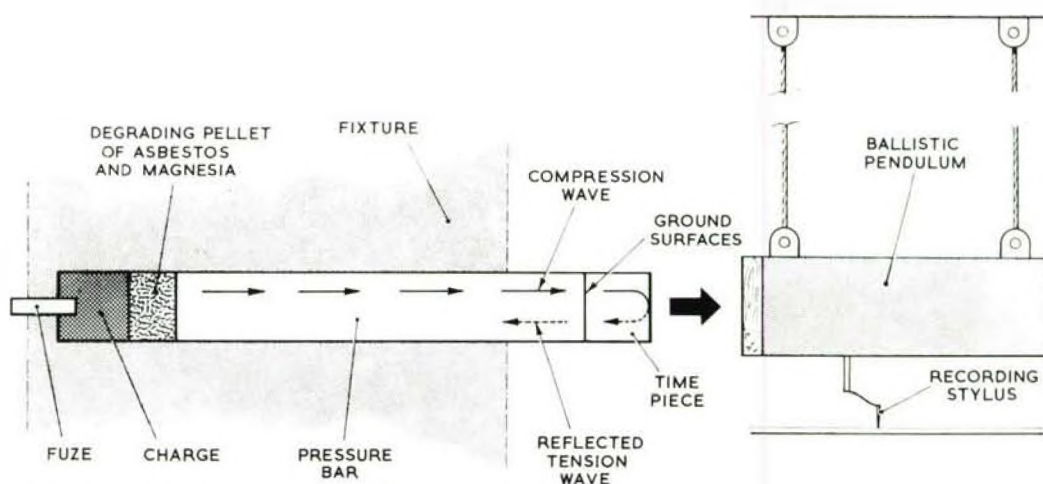

Fig. 8 Diagrammatic sketch of Hopkinson pressure-bar apparatus

76. Because the actual detonation pressure is so high that it would deform the steel bar it is necessary to interpose a 'degrading pellet' of compressed asbestos and magnesia between the explosive and the bar; thus the measured pressures are of the order of 60 ton/in<sup>2</sup>, with the consequence that the pressure bar is more useful as a comparative instrument and for the control of uniformity of manufacture of detonators and exploder pellets than for direct measurement. It will be appreciated that to cope with explosive effects varying from that of small detonators to that of large exploder pellets, different sizes of bar are required (0.7 inch, 1.0 inch and 2.0 inch diameter bars are used).

77. In recent years methods have been devised to obtain absolute values of the detonation pressure, but they are not useful for routine measurements as they depend on the use of high-speed photography and on the employment of specially designed initiatory charges to impart a controlled shock wave to the explosive under test. In one such method the test charge is detonated at the base of a column of either water or perspex and the passage of the resulting shock wave through the translucent medium is photographed using a 'streak' camera. From the known physical properties of these two media, which have been widely studied, it is possible to deduce the detonation pressure. In another method wedge-shaped pieces of metal having one face silvered to act as a small mirror are stuck to the end of a charge opposite to the initiation system and the movement of the face is photographed as the detonation wave emerges from it. By using different metals in a series of experiments it is again possible to deduce the detonation pressure of the explosive under examination.

78. If a value of the  $V$  of  $D$  is available a rough estimate of the detonation pressure,  $P$ , of an explosive charge may be obtained from the expression

$$P = \frac{1}{2} \rho D \quad \text{--- (52)}$$

where  $\rho$  is the density of the charge and  $D$  is the  $V$  of  $D$  of the explosive.

## CHAPTER 5

**The Manufacture and Properties of Inorganic Compounds used in  
the Explosives Industry**

## CONTENTS

	<i>Para</i>
<b>Introduction</b> .....	1
<b>Ammonia, Nitric acid, Nitrates and Nitrogen tetroxide</b> .....	2
<i>Ammonia, NH<sub>3</sub></i> .....	2
<i>Nitric acid, HNO<sub>3</sub></i> .....	5
<i>Ammonium nitrate, NH<sub>4</sub>NO<sub>3</sub></i> .....	10
<i>Nitrogen tetroxide, N<sub>2</sub>O<sub>4</sub></i> .....	14
<b>Sulphuric acid, Oleum, 'Mixed acids' and Acid recovery</b> .....	16
<i>Sulphuric acid, H<sub>2</sub>SO<sub>4</sub></i> .....	16
<i>Oleum</i> .....	18
<i>'Mixed acids'</i> .....	19
<i>Acid Recovery</i> .....	21
<b>Miscellaneous chemicals</b> .....	25
<i>Charcoal</i> .....	25
<i>Sulphur</i> .....	28
<i>Potassium nitrate, KNO<sub>3</sub> (Saltpetre)</i> .....	31
<i>Barium nitrate, Ba(NO<sub>3</sub>)<sub>2</sub></i> .....	32
<i>Powdered metals (aluminium, magnesium, boron, silicon)</i> .....	33
<i>Mercury</i> .....	36
<i>Phosphorus</i> .....	38
<i>Antimony sulphide</i> .....	40
<i>Titanium dioxide, TiO<sub>2</sub></i> .....	41
<i>Potassium chlorate, KClO<sub>3</sub></i> .....	42
<i>Ammonium and potassium perchlorates, NH<sub>4</sub>ClO<sub>4</sub> and KClO<sub>4</sub></i> .....	43
<i>Lead acetate and other lead compounds</i> .....	47
<i>Sodium azide, NaN<sub>3</sub></i> .....	48
<i>Hydrogen peroxide, H<sub>2</sub>O<sub>2</sub></i> .....	49
<i>Hydrazine, N<sub>2</sub>H<sub>4</sub></i> .....	53
<i>Boranes</i> .....	56

## Illustrations

<i>Fig</i>		<i>Page</i>
1	Pressure oxidation of ammonia .....	4
2	Concentration of sulphuric acid by submerged combustion .....	7
3	Electrolytic-cell battery. Sodium chlorate suffers electrolytic oxidation to perchlorate. Ammonium chloride is then added to the electrolysis liquor .....	11
4	Evaporative crystallizer producing ammonium perchlorate crystals from the reaction liquor .....	11
5	Drying of ammonium perchlorate crystals in a rotary drier .....	12

## CHAPTER 5

## The Manufacture and Properties of Inorganic Compounds used in the Explosives Industry

### Introduction

1. It is not proposed to discuss general inorganic chemistry in this Chapter; most readers will have an adequate background and others will have access to textbooks (see Bibliography). Nor is it proposed to discuss manufacturing methods in detail, but rather to outline those features which are relevant (a) where the manufacture is intramural (that is, takes place in Royal Ordnance Factories) or (b) to the desired properties of the product when it is made in outside industry; more detail will often be found in the encyclopaedias of industrial chemistry (for example, that of Kirk and Othmer), but it must be remembered that many processes are the subject of constant improvement and that, anyhow, the actual operation of a process often involves fine points of detail which are not given in technical descriptions.

### Ammonia, Nitric Acid, Nitrates and Nitrogen tetroxide

#### *Ammonia, NH<sub>3</sub>*

2. It has been implied in Chapters 1 and 2 that the most important classes of explosive compounds are nitro-compounds or nitric esters, and that nitric acid is essential to their manufacture. At present all such nitric acid is derived from ammonia, which is a chemical of such wide economic importance that much attention has been given to the development in industry of huge central plants for its manufacture. The processes employed are still essentially based on the Haber-Bosch discoveries (1908-1913) relating to the direct combination of nitrogen and hydrogen under pressure in presence of a 'promoted' iron catalyst at moderately low temperatures (450°C-550°C). Some of the modern processes employ modifications of the basic process and aim to improve thermal efficiency, but probably the most interesting changes have been those relating to the sources of hydrogen, which was originally derived from 'water gas' but is now more economically obtained as a by-product of the petrochemical industry either by the partial oxidation of hydrocarbons or by the reaction of methane with steam; the source of hydrogen is conditioned by local economic circumstances, but nitrogen is still produced by fractionation of liquid air. The product of the commercial synthesis process is anhydrous liquid ammonia. The following are the more important properties of ammonia:

Critical temperature	133°C
Critical pressure	11425kN/m <sup>2</sup>
Freezing point	-78°C at 101kN/m <sup>2</sup> (1 atm)
Boiling points	-16°C at 231kN/m <sup>2</sup>
	0°C at 429kN/m <sup>2</sup>
	16°C at 742kN/m <sup>2</sup>
	32°C at 1245kN/m <sup>2</sup>
Density	0.62 g/ml

3. In view of the above properties it is possible to transport liquid ammonia under pressure in mild-steel tank waggons, from which it can be expelled under excess gas pressure into well-cooled storage tanks. Modern storage tanks are spherical, and are kept cooled by taking off ammonia gas from the top as the pressure rises, recompressing and cooling it and returning it as cold liquid to the bottom of the sphere. All pipework and fittings must be of steel; copper and zinc must never be used, and mercury-filled instruments (for example, thermometers and manometers) should not be used since mercury may react with ammonia to form explosive compounds.

4. Ammonia containers must never be subjected to heat; even solar radiation should be guarded against. Ammonia will burn in air, and certain ammonia/air mixtures are ignitable, so that safety precautions should be taken with electrical equipment. Gas masks should be worn when working with ammonia since ammonia vapour is toxic.

#### *Nitric acid, HNO<sub>3</sub>*

5. Although nitric acid of all concentrations can be transported in stainless-steel tank waggons, and 95 to 99% nitric acid in aluminium tankers (somewhat to be preferred at that concentration), it is usual in any explosives factory of reasonable size to make the acid on site. The process employed is essentially that of the oxidation of ammonia as originally developed by Ostwald in the years 1901-08, whereby ammonia is passed with excess air over platinum gauzes stretched across a stainless-steel (converter) chamber (Fig. 1). The platinum is alloyed with 5% rhodium to increase its strength. The operating temperature is about 850°C at atmospheric pressure† or 900°C at 4 atm, control over the temperature being exercised by

† 1 atmosphere = 101.325kN/m<sup>2</sup>

regulating the proportion of air used. The immediate product is nitric oxide, NO, the oxidation of which to nitrogen peroxide, NO<sub>2</sub>, by the excess air is a relatively slow process. (Note: Nitrogen peroxide is often called nitrogen tetroxide, because the equilibrium  $2\text{NO}_2 \rightleftharpoons \text{N}_2\text{O}_4$  tends to the right at lower temperatures, for example, room temperatures).

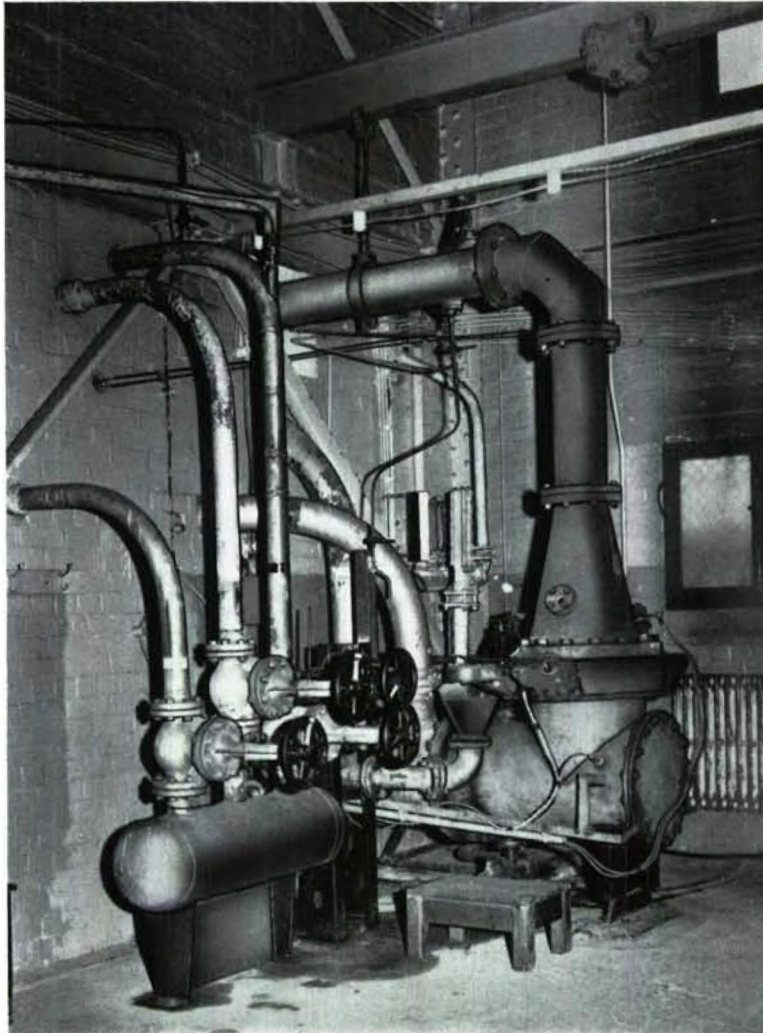

Fig. 1 Pressure oxidation of ammonia

6. The hot gases from the converter are cooled by passing them through stainless-steel heat exchangers where part of the cooling water is converted to steam which can be used elsewhere in the plant (for example, for evaporation of ammonia or for environmental heating). The gases are then passed to stainless steel towers packed with contact media\* where they meet a flow of water and are absorbed to yield nitric acid at a concentration of about 55% if the plant is operated at atmospheric pressure or about 65% if the operating pressure is 4 atmospheres. Some of the more modern designs of plant operate at pressures of 8-10 atm and have elaborate recovery systems to regain the heat and pressure energy of the converter gases. The concentration of ammonia in the gases fed to the converter is held at  $10 \pm 0.5\%$  because the explosive limit of ammonia/air mixtures is approached at 12%. With careful attention to detail the consumption of platinum catalyst is about 147 mg per 1000 kg of acid produced.

7. However, the synthetic nitric acid so produced is at concentrations too low for use in the explosives industry. Much of it is concentrated by mixing it with concentrated sulphuric acid at the top of a tower built of suitable acid-resisting materials (for example, 13% silicon-iron, silica, glass) and packed with graded quartz; super-heated steam is passed into the bottom of the tower. The composition of the mixed acid feed to the tower is so adjusted that 72% sulphuric acid leaves the base of the tower whilst a

\* Contact media may be, for example, earthenware or stainless-steel rings or stainless-steel bubble-caps with cooling coils. Many designs of packing media have been produced, aiming at large surface area combined with low resistance to gas flow.

concentrated nitric acid vapour passes from the top of the tower to an aluminium or silica condenser from which it emerges (after blowing air through it to remove free nitrogen oxides) as an acid of about 99.5% concentration.

8. Another process for the concentration of the product of the ammonia oxidation plant is to mix it with liquid nitrogen tetroxide (condensed from the cooled converter gases before they enter the absorption towers) and treat the mixture with oxygen under pressure. This was the principle of the Bamag process which was operated at ROF Irvine in the 1939-45 War; it was a batch process employing an autoclave for the oxygenation treatment. The materials of construction and design of the autoclave called for considerable chemical engineering work, but the process operated satisfactorily. In some other countries since that war it has been developed for continuous operation, but it has not yet been widely adopted in commerce on account of high capital costs.

9. The more important physical properties of nitric acid are:

bp	86°C
fp	-41°C
Density at 20°C	1.513 g/ml
Partial pressure at 20°C	45 mmHg (partial pressure of water is 17.5 mmHg)

It is a strong oxidizing agent and must not be allowed to come into uncontrolled contact with flammable matter or, of course, with any part of the human anatomy. Its vapours are toxic as well as productive of lung oedema. It is best handled in aluminium or (particularly at concentrations below 95%) in stainless steel equipment, and great care must be exercised in welding and in the selection of pipe-jointing materials.

#### *Ammonium nitrate, NH<sub>4</sub>NO<sub>3</sub>*

10. This salt is, of course, produced by the neutralization of nitric acid by ammonia. But whereas it used to be customary to carry out this step in presence of a large excess of water, which then had to be evaporated off, it is now customary to perform it by introducing gaseous ammonia and nitric acid (at the concentration in which it is produced in the ammonia oxidation process) into the bottom of a very concentrated (90-95%) aqueous solution ('melt' would almost be a better description) of ammonium nitrate at about 150°C. The operation is carried out in a vessel from which the water introduced with the nitric acid is removed as steam (due to the heat of neutralization) while the excess ammonium nitrate melt is sprayed into a very tall (300 to 600 m) tower up which cold air is forced, causing the ammonium nitrate to form spherical pellets ('prills') which still retain most of the water. These pellets are then dried in stages to 0.15% water content, suitable for explosives purposes, where the properties of ammonium nitrate as an oxidizing agent are useful.

11. Ammonium nitrate is a colourless salt which melts at 170°C when pure and dry. It exists in five crystalline forms, which are stable over the following temperature ranges:

Form	Stable Range
α or V	Below -16°C
β or IV	-16 to +32°C
γ or III	32 to 84°C
δ or II	84 to 125°C
ξ or I	125 to mp

The β-form is denser than the γ-form, the volume increase corresponding to 3.4%; the γ-form is less dense than the δ-form, the volume decrease corresponding to 1.6%. The β-γ transition temperature of 32°C is of importance in the filling of ammonium nitrate compositions, the filling shrinks on cooling with formation of an air gap unless a 'topping' is given. Conversely, a filling tends to expand on storage in hot climates. In the drying (by heating) of ammonium nitrate for the manufacture of compositions, the strain produced in the crystals at the γ-δ transition point (84°C) assists in reducing the nitrate to a fine powder.

12. Ammonium nitrate is very soluble in water, which dissolves 1.2 times its weight at 0°C and 11 times its weight at 100°C. It begins to decompose at 220°C:



and may decompose explosively at 260°C. If well confined — even under its own weight in large quantities — ammonium nitrate can be brought to detonation by a suitable priming charge. When mixed with combustible matter it will explode if involved in a fire.

13. It should not be brought into contact with copper or copper alloys since it sometimes gives rise to unstable copper compounds; a purplish cuprammonium nitrate is somewhat sensitive to shock and both it and copper nitrate lower the temperature of ignition of amatol (qv Chapter 7). Ammonium nitrate tends

to promote corrosion of iron and steel, which must be protected against it (for example, by stoved copal varnish), and it attacks lead, though without formation of dangerous products. It is best handled in aluminium or stainless-steel equipment.

*Nitrogen tetroxide, N<sub>2</sub>O<sub>4</sub>*

14. As noted in para. 5, nitrogen tetroxide, a deep yellow liquid, can be condensed from the cooled gaseous products of the ammonia oxidation converter. It boils at 21°C and freezes at -11°C (white crystals). It is very toxic and readily causes lung oedema; the safe limits of concentration in the atmosphere are very low (below 10 ppm).

15. It is a powerful oxidizing agent, in which capacity it has been used, either alone or in solution (ca 20%) in nitric acid, as the oxidant in some 'bifuel' liquid-propellant systems. It is best handled in aluminium containers.

**Sulphuric acid, Oleum, 'Mixed acids' and Acid recovery**

*Sulphuric acid H<sub>2</sub>SO<sub>4</sub>*

16. As it has always been, the immediate raw material for sulphuric acid is sulphur dioxide, SO<sub>2</sub>, which is usually obtained either by the combustion in air of sulphur or by the roasting in a stream of air of sulphur-bearing natural ores which have been mined as the source of metals, for example, iron, copper or zinc. These are the most economic sources of SO<sub>2</sub>, but when (as happened at the time of the Korean War) supplies of natural sulphur become short it is possible to obtain sulphur trioxide directly from gypsum by roasting it with silica (to yield also a form of cement). In any event, sulphur trioxide, SO<sub>3</sub>, must be made, and this is usually done nowadays by passing cleaned and dried SO<sub>2</sub> together with excess air over a suitable catalyst (usually a proprietary mixture of oxides, of which vanadium pentoxide is an important constituent). The SO<sub>3</sub> so produced is cooled and passed to the bottom of a packed steel tower, lined with acid-resisting brick, down which 99% sulphuric acid is fed at a rate which permits a rise in strength in the tower of not more than 0.6%. The acid leaving the tower is diluted to 99%, cooled and part of it recirculated.

17. Sulphuric acid has the following physical properties:

Density:	1.842 g/ml
bp	338°C
fp	10.4°C at 100% concentration
	3.0°C at 98% concentration

It is very hygroscopic, forming a dihydrate, H<sub>2</sub>SO<sub>4</sub>.2H<sub>2</sub>O, which boils at 167°C and freezes at -39°C.

*Oleum*

18. If it is desired to produce oleum, a solution of sulphur trioxide in sulphuric acid, the absorption towers mentioned in para. 16 are designed to be of relatively larger diameter and the feed of sulphuric acid is reduced in relation to that of the sulphur trioxide containing gases; the heat of solution of the SO<sub>3</sub> is removed in external coolers. By a suitable arrangement of towers, oleums containing up to 60% of free SO<sub>3</sub> by weight can be obtained. These may be required either to fortify 96% sulphuric acid or for use in exceptionally 'strong' nitrating acid mixtures. Their utility may be seen from the fact that H<sub>2</sub>SO<sub>4</sub> (molecular weight equal to 98) may be considered as composed of SO<sub>3</sub> (molecular weight equal to 80) and H<sub>2</sub>O (molecular weight equal to 18), so that a '40% oleum' (that is, one containing 40% of free SO<sub>3</sub>) may be regarded as '109% sulphuric acid'. Particular reference is made to 40% oleum because it was much used in explosives plants in spite of its rather high freezing point (32°C), a problem which was overcome by adding 6% of nitric acid to it.

*Mixed Acids*

19. A few explosives could be made using nitric acid as the nitrating agent, but in practice RDX is the only one which is so made — and must be, because sulphuric acid decomposes RDX. Nitration reactions are invariably accompanied by the production of water, 1 molecule for each reacting molecule of nitric acid. This results in dilution of the nitration medium, so that the rate of reaction would be reduced unless some action was taken to remove the water from the reaction system. Physical means to this end being impossible, as they would call for inconveniently high temperatures, it is usual to have recourse to the use of sulphuric acid, which forms a fairly stable monohydrate.

20. Thus the first step in the preparations for most nitration processes is to make up the appropriate mixed acids. This is usually done by measuring into a mild steel tank, fitted with stirring gear and cooling coils (sometimes made of lead to cope with the problem of the corrosive effects of the acid atmosphere above the general acid level), a quantity of concentrated sulphuric acid, mixing in oleum if necessary, and then stirring in the calculated measured quantity of nitric acid. This is followed, if required, by such measured quantity of water as may be calculated to give an acid of the appropriate

water-content. When mixed acids are to be used in the nitration of cellulose, the ratio of nitric acid to water is an important factor in controlling the 'nitrogen value' (that is, the percentage of nitrogen in the molecular structure) of the final nitrocellulose. The mixed acids so made are, of course, always analysed before use and any necessary adjustments of composition made before they leave the mixing plant.

#### *Acid recovery*

21. When a nitration process has been completed and the required explosive, or intermediate compound, removed from the mixture, a 'waste-acid' remains. This acid is weaker in nitric acid but richer in water than the original nitrating acid. In some instances (for example, the manufacture of TNT) it can be used in an earlier stage of the process; in others a part of the waste acid can be refortified with nitric and sulphuric acids to yield a nitrating acid. But usually either part or all of the waste acid must be subjected to a 'recovery' process the object of which is to separate the remaining nitric and sulphuric acids and obtain them in concentrated form ready for re-use. The first stage is 'denitration', which is effected by feeding the waste acid, together with any necessary sulphuric acid, into the top of a tower precisely like that used in the concentration of the weak nitric acid obtained in the ammonia oxidation process (see para. 5). The composition of the acid fed to the top of the tower is adjusted so that, while concentrated nitric acid is distilled off, the acid leaving the foot of the tower is 72% sulphuric acid.

22. The sulphuric acid from the 'denitration tower' must then be reconcentrated to 96-98%. In the 1939-45 War the Bamag process was adopted to do this. In this process the weak acid is fed continuously to a stirred silicon-iron vessel, mounted so that it can be heated by a gas- or oil-fired furnace to a temperature of about 285°C; the water is driven off and concentrated sulphuric acid passes continuously to coolers.

23. In the two processes so outlined, substantially all organic matter in the waste acid is destroyed.



Fig. 2 Concentration of sulphuric acid by submerged combustion

24. For the concentration of weak sulphuric acid, consideration has also been given to the Nordac process in which the weak acid is sprayed continuously into a chamber at the base of which a 'submerged flame' is burning in a pool of concentrated acid, Fig. 2. If the throughput is large and uninterrupted this process appears advantageous, but the maintenance of the plant might be costly if the process is subject to interruption.\*

### Miscellaneous Chemicals

#### Charcoal

25. Charcoal is for present purposes the product of the destructive distillation of wood, the yield being usually of the order of 28-29% of the wood. The charcoal so produced has a porous structure (which facilitates its combustion) and usually contains residues of tarry matter. For the purposes of gunpowder manufacture the preferred woods for use in making charcoal were dogwood (for rapid-burning powders) and alder or willow (for large-grain powders).

26. It was, until fairly recent times, the practice to load short lengths of the well-seasoned wood into cylindrical cast-iron retorts mounted horizontally in the flue of a wood- or coal-fired furnace; the retort was closed with a cast-iron plate luted into place with fireclay, and it had a small hole for the escape of the products of distillation which were evolved as the temperature of the retort rose to between 400°C to 500°C. A typical analysis by weight of the residual charcoal was:

Carbon 81%    Hydrogen 3%    Oxygen 14%    Ash 2%

27. When it is considered how vital to the ballistic regularity of the gunpowder are the characteristics of the charcoal employed in its manufacture, it is remarkable how, with such crude — and totally uninstrumented — carbonization plant, the workers of the 19th century succeeded in making reliable charcoals. It is today more usual to make the charcoals by loading into rotary drums chips of the appropriate wood and having the drums rotate in heated metal baths whose temperature can be closely controlled.

#### Sulphur

28. In early times sulphur was mined in some countries. One country, for example, where this was done was Sicily. In more recent times rich sources of subterranean sulphur were found offshore in the Gulf of Mexico; these were worked by forcing superheated water down one tube of a double-walled borehole whereupon a molten sulphur/water slurry came up the other tube. More recently still, the 'sour gases' obtained from natural gas or from the processing of crude petroleum have formed a source of sulphur; these gases contain hydrogen sulphide,  $H_2S$ , which is separated from the hydrocarbon gases and part of which is burned to yield sulphur dioxide which is then reacted with the remaining  $H_2S$ .



29. The early crude sulphurs were purified by heating them to the boiling point (444°C) whereupon they sublimed to yield a finely-divided product known as 'Flowers of sulphur'. However, it was found that on storage this product developed acidity (due to the oxidizing effect of moist air on the fine particles) and so it was preferred to remelt it (mp is 114°C) and cast it in stick form ('roll' sulphur), it became the practice to melt the crude sulphur at once, filter it and then cast it.

30. Sulphur exists in the form  $S_8$  in three modifications as follows:

- $\alpha$  (density 2.07 g/ml; mp 112.8°C)
- $\beta$  (density 1.96 g/ml; mp 119.0°C)
- $\lambda$  (density 1.92 g/ml; mp 120.0°C, about)

The  $\alpha$  form is the form normally met with.

#### Potassium nitrate, $KNO_3$ (Saltpetre)

31. The early sources of potassium nitrate were decaying animal and vegetable matter in which the action of certain bacteria had assisted the oxidation to nitrous and nitric acids of nitrogen compounds such as urea and uric acid. Climatic and other conditions in India were particularly favourable to these processes, and large tonnages of saltpetre were exported thence as the gunpowder industry developed.

\*ROF Bishopton has an oil-fired submerged combustion unit for the concentration of weak sulphuric acid to the point where it can be reused or sold. Maintenance has indeed proved troublesome and costly due to corrosive attack on the brick linings of the ducting, etc.

Later, when large deposits of sodium nitrate were found in Chile ('Chile saltpetre'), it became the practice to prepare the potassium salt from the sodium salt by double decomposition and fractional crystallization:



The required potassium chloride was found in the form of natural deposits as, for example, at Stassfurt. This process is still employed although the sodium nitrate now used is derived from synthetic nitric acid. The density of potassium nitrate is 2.11 g/ml.

#### *Barium nitrate, Ba(NO<sub>3</sub>)<sub>2</sub>*

**32.** Is the product of reaction of naturally occurring barium carbonate (Witherite) with nitric acid. Its density is 3.25 g/ml.

#### *'Powdered' metals (aluminium, magnesium, boron, silicon)*

**33.** *Aluminium and magnesium.* These metals are produced in finely divided form either by mechanical attrition ('rasping') in an inert atmosphere or by spraying or 'blowing' molten aluminium in a high-velocity inert gas stream (Al mp is 660°C; Mg mp is 651°C).

Both metals are readily oxidized, with considerable evolution of heat:

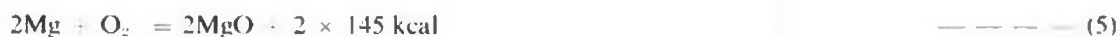

Their densities are: Al = 2.70 g/ml; Mg = 1.74 g/ml.

**34.** *Boron and silicon.* In massive form, as produced in commerce, these elements are hard but brittle. They are therefore usually reduced to powder form by hammer-milling, any traces of iron being removed by treatment with hydrochloric acid.

**35.** Boron and silicon are not highly reactive, but under suitable conditions can be burnt with evolution of heat.



Their densities are: B<sub>(cryst)</sub> = 2.34 g/ml; B<sub>(amorph)</sub> = 2.37 g/ml; Si = 2.33 g/ml.

#### *Mercury*

**36.** This metal is derived from the mineral 'cinnabar' (which is mercuric sulphide) by roasting, which volatilizes the mercury. Hitherto, cinnabar has been the only practicable source of mercury, and even it is found in limited quantities in only a few parts of the world, so that there is currently a grave risk of shortage of supplies of the metal.

**37.** Mercury has the following physical properties:

Density 13.594 g/ml

bp 356.6°C

fp -38.87°C

It has a low, but appreciable, vapour pressure and as the element is toxic it should therefore preferably not be allowed to lie about in the open in laboratories, etc.

#### *Phosphorus*

**38.** This element is derived from the mineral calcium phosphate ('phosphate rock'), found in several parts of the world, but principally in North Africa and some Pacific islands. The powdered rock is heated in an electric furnace with sand and coke; the reaction may be roughly described:



The element exists in two allotropic modifications:

(1) *White phosphorus* is the form resulting from the above process and of interest for certain incendiary stores. White phosphorus is very flammable and has an ignition temperature in air of 38°C to 40°C. White phosphorus is very toxic, and therefore is never used if the red (non-toxic) form can be employed.

(2) *Red phosphorus* is the form of interest for pyrotechnics and ignition compositions. It can only be ignited with some difficulty at about 260°C. Red phosphorus is made by heating white phosphorus to about 240°C for several hours in presence of a small quantity of iodine (catalyst). The crude product is ground under water and boiled with caustic soda to remove remaining white phosphorus. If red phosphorus is heated under pressure to 610°C it reverts to the white form.

39. Phosphorus has the following physical properties:

	Yellow	Red
Density	1.82 g/ml	2.34 g/ml
bp	280°C	—
fp	44.1°C	590°C at 43 atm (4357kN/m <sup>2</sup> )

#### *Antimony sulphide*

40. This occurs naturally as the mineral stibnite, which is very hard and is reduced to powder form by hammer-milling. It is an adequately pure form for most purposes of antimony trisulphide, Sb<sub>2</sub>S<sub>3</sub>, of density 4.64 g/ml.

#### *Titanium dioxide, TiO<sub>2</sub>*

41. Titanium dioxide is nowadays produced in large tonnages in a finely divided form for industrial purposes, for example, as an ingredient of paints. It occurs widely in natural deposits as rutile and ilmenite, but is in association with the oxides of iron, aluminium and silicon. Several processes have been studied for the extraction of pure TiO<sub>2</sub> from the minerals, of which the most widely used has been digestion with sulphuric acid followed by carefully controlled hydrolysis of the mixed titanium and iron sulphates in hot water so that titanium dioxide is precipitated preferentially. The hydrated dioxide is then calcined, to remove water, and milled. The substance TiO<sub>2</sub> is a white crystalline powder of density ca 4.2 g/ml; it is stable on heating, decomposing only at 1640°C.

#### *Potassium chlorate, KClO<sub>3</sub>*

42. This is usually made by the double decomposition of sodium chlorate with potassium chloride in aqueous solution, sodium chlorate being very soluble and potassium chlorate being appreciably less soluble than sodium chloride. Sodium chlorate is nowadays made by the electrolysis of sodium chloride in aqueous solution in presence of some sodium chromate. The sodium chromate reduces losses due to the cathodic reduction of the intermediate sodium hypochlorite, NaOCl, whilst also reducing corrosion of the steel vessels employed. Potassium chlorate is a white crystalline substance of density 2.32 g/ml and melting point 368°C; it decomposes at 400°C to yield oxygen and KCl.

#### *Ammonium and Potassium perchlorates, NH<sub>4</sub>ClO<sub>4</sub> and KClO<sub>4</sub>*

43. These are made from sodium perchlorate by double decomposition processes. Sodium perchlorate is produced by the electrolysis (Fig. 3) of a concentrated solution of sodium chlorate at a temperature of 30°C to 35°C, using anodes of platinum on copper or platinum on titanium and a voltage of 7.5 volts. This produces a liquor containing 700 g/litre of sodium perchlorate and almost no residual chlorate. Double decomposition to yield ammonium perchlorate may be effected either by adding a strong solution of ammonium chloride or of ammonium sulphate or, in the more modern process, by injecting ammonia and hydrochloric acid gases in stoichiometric proportions, thus avoiding adding extra water to the system. The latter process, operated in the USA, is more economical and gives a purer product.

44. If it is to be used in composite propellants, the ammonium perchlorate so made must be subjected to recrystallization and drying processes. Recrystallization is effected in vacuum evaporators (Fig. 4) to ensure minimal occlusion of impurity and of water in the crystal. After rigorous drying (Fig. 5), and immediately before incorporation into a propellant composition, the crystalline product is subjected to carefully controlled grinding operations to ensure a close control over the particle-size distribution within a range of 1 to 100 micrometres.

45. Ammonium perchlorate forms colourless rhombic crystals of density 1.95 g/ml; it is soluble to the extent of about 20 g/litre in water at 15°C and is slightly soluble in alcohol and acetone. It undergoes crystalline transition to the cubic form at 240°C. At about 270°C slow thermal decomposition occurs with evolution of acid fumes, but this ceases after about 30% of the perchlorate has been consumed; on stronger heating to between 350°C to 400°C further more vigorous decomposition occurs without melting, and at about 450°C vigorous deflagration takes place. The thermal decomposition is catalyzed by compounds of iron, chromium and copper, copper chromite being particularly effective. The pure salt can be detonated under some circumstances when finely divided and subjected to strong initiation, but it

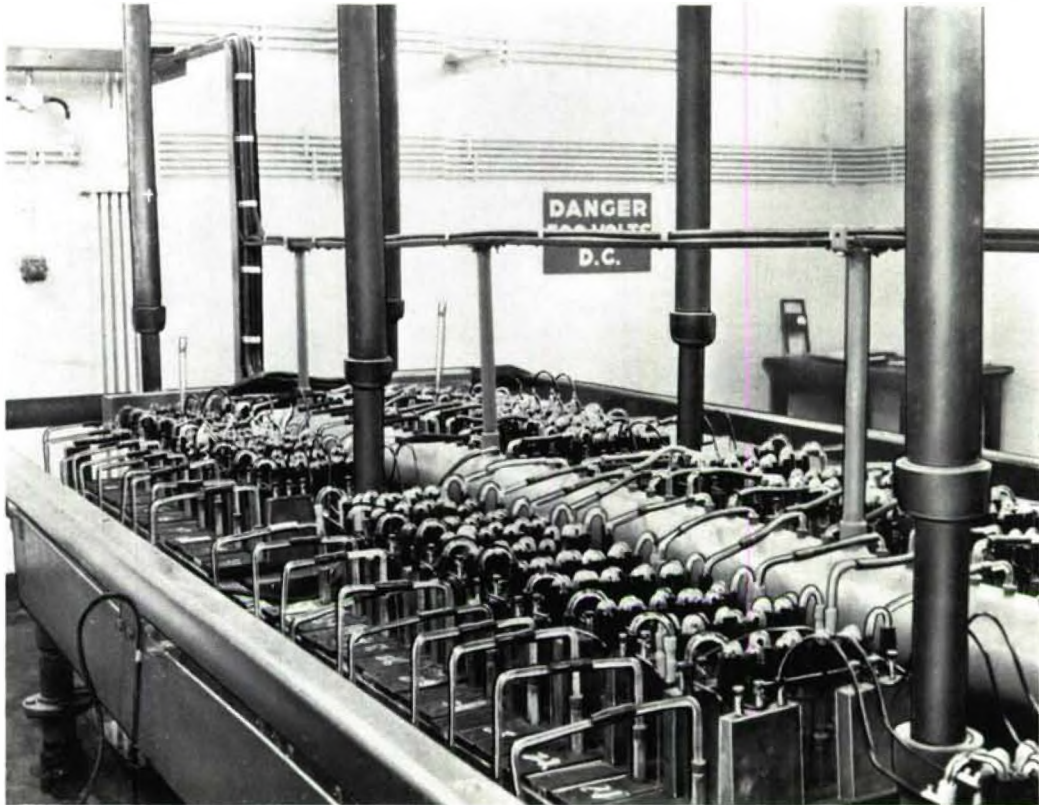

**Fig. 3** Electrolytic-cell battery. Sodium chlorate suffers electrolytic oxidation to perchlorate. Ammonium chloride is then added to the electrolysis liquor.

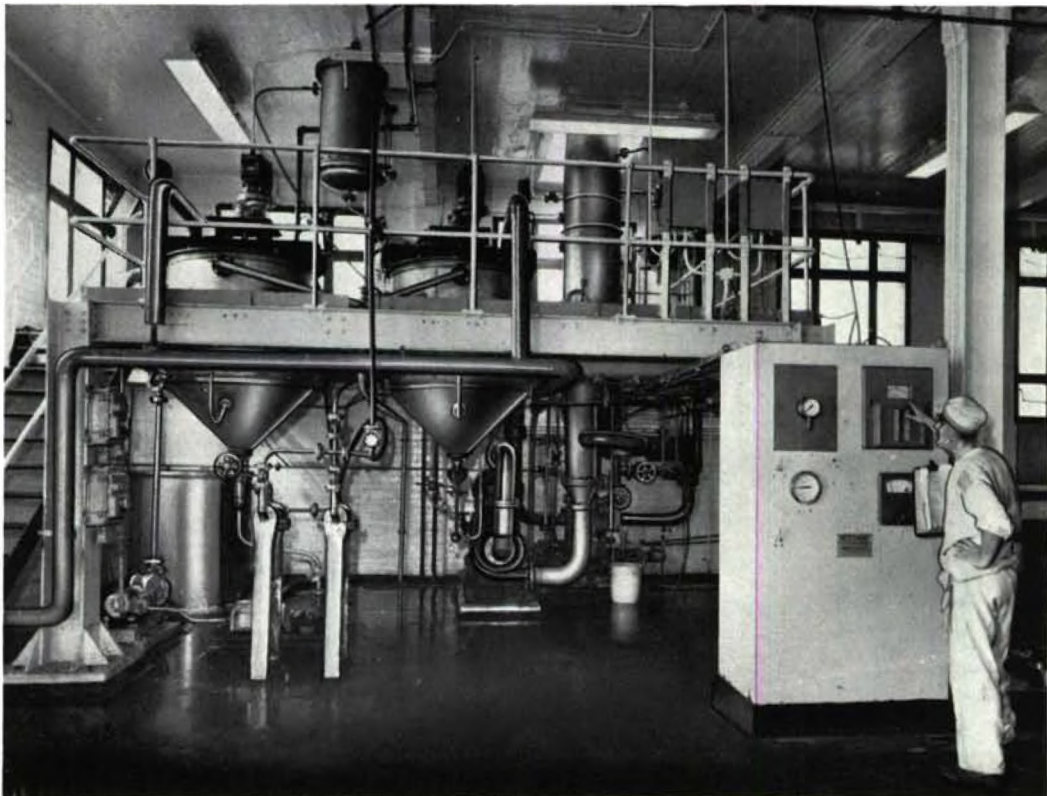

**Fig. 4** Evaporative crystallizer producing ammonium perchlorate crystals from the reaction liquor.

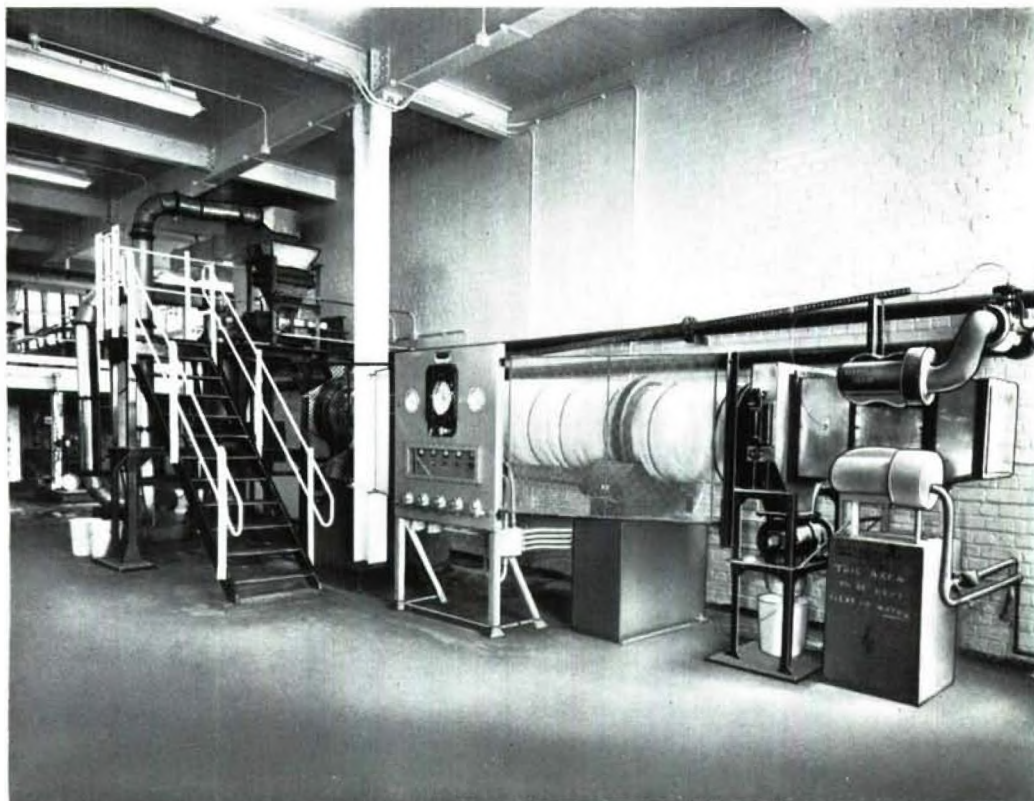

**Fig. 5** Drying of ammonium perchlorate crystals in a rotary drier

is normally sufficiently insensitive to permit of its being handled outside the provisions of the Explosives Acts, although (like other powerful oxidizing agents) it becomes hazardous if contaminated with small amounts of fuels, for example, oil or other combustibles. Arising from its use as an important ingredient of modern solid propellants for rocket motors there is an extensive literature on its thermal decomposition, alone and in association with fuels.

**46.** Potassium perchlorate is also prepared from sodium perchlorate by double decomposition with potassium chloride, and has some of the properties of the ammonium salt, although it is not detonable unless in admixture with combustible matter. Its specific gravity is 2.53 g/ml and it undergoes crystal phase transition at 300°C, after which it remains stable up to 653°C when it decomposes to yield potassium chloride and oxygen. It has limited application in propellants, but is principally important as an oxidant in pyrotechnic compositions.

#### *Lead acetate and other lead compounds*

**47.** Lead acetate,  $\text{Pb}(\text{OOC}\cdot\text{CH}_3)_2\cdot 3\text{H}_2\text{O}$ , because of its high solubility in water, has long been used for the manufacture of those lead compounds which are conveniently prepared by processes of double decomposition, and so was adopted as the source of the lead radical in lead azide. It was formerly prepared by the cold atmospheric oxidation of lead in presence of dilute acetic acid, but is now made by dissolving litharge,  $\text{PbO}$ , in hot dilute acetic acid. Lead compounds of other organic acids of higher molecular weight are made by boiling in water stoichiometric proportions of litharge and the appropriate acid, but as the molecular weight of the acid increases the reaction becomes more difficult and the composition of the resulting product tends to deviate from that of a true lead salt and to approximate to that of a basic salt; such is the case with lead stearate, lead acetylsalicylate and lead 2-ethylhexoate, to quote some compounds of interest as 'ballistic modifiers' in the field of rocket propellants of the double-base type (see Chapters 8 and 12). Compounds which approximate more nearly to true salts are obtained if a soluble lead salt is reacted with the appropriate organic acid in presence of the calculated amount of caustic soda, but are then difficult to free from traces of sodium salt.

#### *Sodium azide, $\text{NaN}_3$*

**48.** Although, as the textbooks say, sodium azide can be made by reaction of nitrous oxide,  $\text{N}_2\text{O}$ , with fused sodamide,  $\text{NaNH}_2$ , at 150°C to 250°C (and, indeed, this method is still in commercial use to some extent), it is also conveniently made by the reaction of ethyl nitrite with hydrazine in presence of sodium ethoxide.



Sodium azide is a white crystalline compound, of density 1.846 g/ml, readily soluble in water and stable up to 200°C.

*Hydrogen peroxide, H<sub>2</sub>O<sub>2</sub>*

49. From about 1910 hydrogen peroxide was made by the electrolysis of dilute solutions of sulphuric acid; it was believed that the mechanism of the process was the anodic oxidation of the acid to form peroxydisulphuric acid which, when the solution was subsequently boiled, hydrolyzed with formation of hydrogen peroxide and free sulphuric acid. The peroxide was distilled from the hydrolysis solution as a weak (ca 3%) aqueous solution, which could be concentrated by vacuum distillation to about 30%, which was at that time the most concentrated hydrogen peroxide commercially available. This process is still in use to a limited extent, but it has been largely superseded in the last 20 or 30 years by the 'autoxidation' process, which is economically superior. This latter process was developed in Germany from about 1934, when Riedel and Pfeleiderer began to take out patents covering the cyclic reduction (by hydrogen in presence of a catalyst) of 2-ethylanthraquinone, dissolved in a suitable mixture of solvents, followed by its re-formation by oxidation (by contacting the solution with air in presence of water which extracted hydrogen peroxide). The aqueous solution so obtained, which may be of 20% or more concentration, is concentrated by a process of careful fractional distillation *in vacuo* to yield a product of about 90% strength known as HTP (High Test Peroxide), see also Chapter 8.

50. Another commercial route to the synthesis of hydrogen peroxide was developed about 1950 in the petrochemical industry, where it was discovered that the oxidation of isopropyl alcohol, CH<sub>3</sub>CH(OH)CH<sub>3</sub>, in the liquid phase in presence of catalysts could be made to yield acetone, CH<sub>3</sub>COCH<sub>3</sub>, and H<sub>2</sub>O<sub>2</sub>.

51. Hydrogen peroxides of concentration in excess of 99% can be obtained from HTP by fractional freezing, but are rarely required. At all concentrations hydrogen peroxide tends to decompose to yield water and free oxygen, with evolution of heat, and this decomposition is accelerated by impurities, so that the manufacture and use of HTP is possible only by the closest attention to the elimination of all forms of contamination; even so, its storage in completely closed vessels is inadvisable. The stability of HTP is increased by the addition to it of small quantities 8-hydroxyquinoline ('Oxine') or, better, sodium stannate; the former yields inert complexes with any traces of catalyst metal ions which may be present, while the latter yields the stannates of such ions as well as adsorbing finely particulate dusts in its colloidal structure.

52. The boiling and freezing points of a few H<sub>2</sub>O<sub>2</sub> solutions in water are:

H <sub>2</sub> O <sub>2</sub> concentration	bp at 760 mmHg (101.33 kN/m <sup>2</sup> )	fp
30	106.2°C	-25.7°C
60	119.0	-55.5
70	125.5	-40.3
80	132.9	-24.8
90	141.3	-11.5
100 (SG = 1.442)	150.2	-0.43

The relatively high freezing point of 100% hydrogen peroxide is one reason why it is of small military interest.

*Hydrazine, N<sub>2</sub>H<sub>4</sub>*

53. The oxidation of ammonia to form hydrazine may be represented schematically as:



In practice, the only industrially usable method for effecting this oxidation is to employ sodium hypochlorite as the oxidizing agent, in an aqueous system:



It is believed that the reaction proceeds in two steps, the first being the formation of chloramine, NH<sub>2</sub>Cl, followed by its reaction with a second molecule of ammonia, the second stage being much slower than the first and calling for the application of heat. Because the second stage is slow, hydrazine which has been formed remains for a relatively long time in presence of unconsumed hypochlorite as well as atmospheric oxygen, with consequent slow oxidation to nitrogen and water; this oxidation is accelerated if certain metal ions (notably copper) are present, so gelatine (or glue) is added to the reaction system to reduce the consequent loss of hydrazine by adsorbing such ions. Aqueous hydrazine (ca 3%) is distilled

off when the reaction is complete, and the distillate is fractionally distilled to yield an azeotrope containing 68% hydrazine, which is then further distilled in presence of aniline, or another suitable third component, to break the azeotrope. The third component is carried off with the water vapour, leaving in the still a concentrated hydrazine which can be finally fractionated to yield 98% to 99% hydrazine (density equal to 1.01 g/ml).

54. The disadvantage of this process, and of variants of it, is the large volume of water originally associated with the hydrazine (more than 30 parts), the subsequent removal of which by distillation is costly. There is also a useless residue of salt, contaminated with gelatine. Other processes have therefore been sought, but it is not known that any are yet in commercial use.

55. Hydrazine is a clear fuming liquid, hygroscopic and toxic (because of its powerful reducing properties); it boils at 113.5°C and freezes at 2°C. It is thermodynamically unstable and readily decomposes on some metal surfaces, for example, rough stainless steel, so that great care is needed in the design and construction of plant in which it is to be processed or stored since the decomposition process can become explosive and the hot vapour of hydrazine may ignite in air.

#### Boranes

56. Although the family of apparently potential fuels comprised in the class of boron hydrides, or 'boranes', is not now of any direct military interest, it is convenient to make brief reference to its since allusion to it may be met. It seemed, about 1955, that boranes might have worthwhile advantages over hydrocarbon fuels for certain applications, with the consequence that very considerable interest was shown in the subject at the time and remarkable advances were made in the chemistry of the boron hydrides during the decade that followed.

57. There were, of course, certain obvious difficulties in the way; boron is not very abundant in nature and occurs only in the oxidized form as boric acid,  $H_3BO_3$ , or as borax,  $Na_2B_4O_7 \cdot 10H_2O$ , so that the reduction of naturally occurring sources of the element to boron hydrides must consume much energy. But a less obvious difficulty was discovered as the work proceeded, namely that it was difficult to burn the hydrides with complete efficiency; instead of burning entirely to  $B_2O_3$  there was a tendency for combustion to proceed only to boron suboxides, chiefly  $B_2O$ , with consequent decrease in energy of combustion. The solid products of combustion also were objectionable in various ways.

58. A number of the boron hydrides were already known as laboratory products, and their characteristics have been described as follows:

	$BH_3$	$B_2H_6$	$B_3H_9$	$B_4H_{10}$	$B_5H_{11}$	$B_6H_{14}$
mp (°C)	-165.5	-120	-46.6	-123	-65.1	+ 99.7
bp (°C)	-92.5	+ 18	43	48	0 at 7 mm	213
Stability	+	-	++	---	-	+

59. It was thus evident that boranes of fairly high molecular weight must be synthesized in order that the products might be liquid at normal temperatures, and it was known that  $B_2H_6$  and  $B_3H_9$  vapours, when heated under suitable conditions yielded  $B_4H_{10}$ . The compound  $B_4H_{10}$  was prepared in good yield by the reduction (using lithium hydride) of boron halides or boric esters in suitable solvent systems, and was 'pyrolysed', by circulation at reduced pressure through a tube system at temperatures between 100°C and 200°C, to yield complex liquid hydrides. If the pyrolysis was carried on in presence of unsaturated hydrocarbons (for example, ethylene) substituted boranes were produced which could be processed to yield 'handleable' fuels. Though of lower energy than boranes they were free from organic groups and still very costly.

60. There has proved to be a very considerable range of boron hydrides, from  $B_2H_6$  to  $B_{10}H_{12}$  — or higher. Some are 'unsaturated' and can be made to react with unsaturated organic compounds to yield addition products which on heating undergo rearrangement to yield 'carboranes', complex structures in which carbon and boron atoms are directly linked.

## CHAPTER 6

**Manufacture and properties of organic compounds used in the  
explosives industry**

**CONTENTS**

	<i>Para</i>
<b>Benzene-chemistry nomenclature</b> .....	1
<b>Phenol, picric acid and ammonium picrate</b> .....	4
<i>Phenol</i> .....	4
<i>Picric Acid</i> .....	5
<i>Ammonium picrate</i> .....	11
<b>Dimethylaniline and tetryl (Composition exploding—CE)</b> .....	14
<i>Dimethylaniline</i> .....	14
<i>Tetryl (CE)</i> .....	16
<b>Toluene and 2:4:6-trinitrotoluene (TNT)</b> .....	22
<i>Toluene</i> .....	22
<i>2:4:6-trinitrotoluene (TNT)</i> .....	24
<b>Resorcinol, 2:4- and 4:6-dinitroresorcinols and 2:4:6-trinitroresorcinol (styphnic acid)</b> .....	34
<i>Resorcinol</i> .....	34
<i>2:4-dinitroresorcinol</i> .....	35
<i>4:6-dinitroresorcinol</i> .....	36
<i>2:4:6-trinitroresorcinol (Styphnic acid)</i> .....	37
<b>Phloroglucinol and trinitrophloroglucinol</b> .....	38
<i>Phloroglucinol</i> .....	38
<i>Trinitrophloroglucinol</i> .....	40
<b>1:3-diamino and 1:3:5-triamino- and 2:4:6- trinitrobenzene</b> .....	41
<i>1:3- diamino- 2:4:6-trinitrobenzene (DATB)</i> .....	42
<i>1:3:5-triamino- 2:4:6-trinitrobenzene (TATB)</i> .....	44
<b>Hexanitrodiphenylamine</b> .....	46
<b>Hexamine, RDX and HMX</b> .....	47
<i>Hexamine</i> .....	47
<i>RDX (Cyclo-trimethylenetrinitramine) prepared by Woolwich process</i> .....	48
<i>RDX (Cyclo-trimethylenetrinitramine) prepared by Bachmann process</i> .....	54
<i>Properties of RDX</i> .....	55
<i>HMX (Cyclo-tetramethylenetetranitramine)</i> .....	56
<b>Pentaerythritol and pentaerythritol tetranitrate (PETN)</b> .....	59
<i>Pentaerythritol (PE)</i> .....	59
<i>Pentaerythritol tetranitrate (PETN)</i> .....	60
<b>Cellulose and nitrocelluloses</b> .....	65
<i>Cellulose</i> .....	65
<i>Nitrocelluloses</i> .....	71
<i>Displacement process for nitrating cellulose</i> .....	75
<i>Mechanical process for nitrating cellulose</i> .....	77
<i>Stabilization of nitrocellulose</i> .....	81
<i>Properties of nitrocellulose</i> .....	82
<b>Glycerine and nitroglycerine</b> .....	84
<i>Glycerine</i> .....	84
<i>Nitroglycerine (Glycerol trinitrate)</i> .....	87
<i>Properties of nitroglycerine</i> .....	92

## CONTENTS (contd.)

<b>Glycols and glycol nitrates</b> .....	99
<i>Glycols</i> .....	99
<i>Glycol nitrates</i> .....	101
<b>Other aliphatic nitrates</b> .....	104
<b>Aliphatic nitrocompounds (nitroparaffins)</b> .....	105
<b>Ethylene dinitramine (EDNA)</b> .....	108
<b>Picrite, coolant plasticizers, stabilizers, moderants</b> .....	109
<i>Picrite</i> .....	109
<i>Coolant plasticizers</i> .....	112
<i>Stabilizers</i> .....	113
<i>Moderants</i> .....	116
<b>Polyisobutylene [C(CH<sub>3</sub>)<sub>2</sub> · CH<sub>2</sub>]<sub>n</sub></b> .....	118
<b>Surface-active agents</b> .....	120
<b>Dimethylhydrazine</b> .....	122

## Illustrations

<i>Fig</i>		<i>Page</i>
1	Benzene-ring structure .....	3
2	Substitution by nitro groups .....	4
3	Preparation of tetryl .....	6
4	The action of sodium sulphite solution on molten TNT .....	8
5	Preparation of resorcinol .....	8
6	Preparation of phloroglucinol .....	9
7	Preparation of triaminotrinitrobenzene (TATB) .....	10
8	Structure of hexamine .....	11
9	Initial reaction between hexamine and nitric acid .....	12
10	Further reaction of hexamine with nitric acid .....	12
11	Chemical structure of cellulose .....	14
12	Displacement nitration .....	16
13	Mechanical nitration .....	17
14	Boiling nitrated cellulose .....	18
15	Nitrocellulose beater .....	18
16	Nitrocellulose manufacture .....	19
17	Synthesis of glycerol from propylene .....	20
18	Nitroglycerine manufacture .....	20
19	Automatic Biazzi plant (Nitroglycerine manufacture) .....	21
20	Control panel for Biazzi plant shown in Fig. 19 .....	22
21	External view of control room for Biazzi plant .....	22
22	The NAB process for the manufacture of nitroglycerine .....	23
23	Two injectors for dual stream nitration of glycerine .....	24
24	Centrifuge for separating nitroglycerine from refuse acid .....	24
25	Nitro-isobutylglycerine (a) and methyl-nitropropanediol (b) .....	26
26	Derivation of EDNA (Haleite) from ethylene diamine .....	27
27	Preparation of picrite .....	27
28	Some coolant-plasticizer esters .....	28
29	Carbamite .....	28

## Table

<i>Table</i>		
1	Vapour pressure of nitroglycerine .....	25

## CHAPTER 9

## Primary Explosives, Sensitizers, and Cap, Igniter and Detonator Compositions

### Primary explosives

#### Primary and secondary explosives

1. 'Primary explosives' is the expression now more frequently used to describe those explosives formerly known in this country as 'initiators'; the change has become desirable partly because 'primary explosives' is a more distinctive description of the substances concerned and partly because in United States practice 'initiators' are devices employed to initiate an explosive system.
2. The assessment of the boundary between 'primary' and 'secondary' (or 'high') explosives is a matter on which there could be considerable argument, depending on the nature and scope of the criteria applied; but it is considered convenient, in the present state of knowledge, to take mechanical sensitiveness as the principal criteria, and explosives showing sensitiveness greater than that of tetryl or, perhaps, PETN are considered to be in the primary explosive class. But such broad classification should not be taken too literally; much depends on the design and use of the munition store in which the explosive is to be employed.
3. Most primary explosives show a relatively low Figure of Insensitiveness (F of I) as measured by the Rotter Impact Test (Chapter 14). Typically the F of I of primary explosives is less than 50, whereas that for such a typical 'high' explosive as RDX is 80, and other high explosives have higher values.\*
4. Besides specifying a low F of I, Service requirements may call for sensitiveness to friction or heat in a primary explosive, and will certainly call for adequate chemical stability and the capacity to withstand (in the form in which the primary explosives are present in the finished munition store) the Service conditions of storage and handling. To these considerations must be added the requirements of safety and reliability in manufacture and in use in the Filling Factories.
5. Finally, after all the other requirements are met the choice of a primary explosive for a Service application may be influenced by its electrical properties.

#### Mercury fulminate

6. The mercuric salt of fulminic acid,  $Hg(OHC)_2$ , was discovered by Kunckel in the 18th century, but was rediscovered by Howard at the turn of the century, when he characterized its explosive properties. (Fulminic acid is known only in solution and has never been separated in the pure state, but its structure is believed to be that of the oxime of carbon monoxide, that is  $C:N.OH$ .) The mercuric salt is strongly endothermic (heat of formation equals  $-65.7$  kcal/g mol) and under suitable confinement it will detonate if subjected to impact, friction or heat (see equation 1).



If laid as a train in the open it will burn without explosion.

7. It is manufactured by what is, in effect, a large-scale laboratory process, using glassware. One part by weight of pure mercury is dissolved in 11 parts of 57.5% nitric acid, to yield a solution of mercuric nitrate (in excess nitric acid) which is poured into 10 parts of 90% ethyl alcohol contained in a large flask. A brisk reaction commences, with evolution of fumes, at first white, then brown, then again white, and the temperature rises from 20°C to over 80°C as mercuric fulminate is precipitated in fine crystals of about 99% purity. After cooling, the supernatant liquid is decanted and the dense crystals are washed free of acid by using several lots of water with decantation. The product is then filtered on muslin and dried in small quantities, as required, at a temperature of about 40°C. It is usually grey or brownish, and can safely be stored in the wet state. It has a density of 4.45 g/ml and a bulk density of 1.7 g/ml.
8. When being pressed into detonators its loaded density is between 3.5 and 4 g/ml. If it is compressed further it becomes less sensitive to all forms of mechanical stimulus, and less receptive to flash. When thus rendered inert it is said to be 'dead pressed'.

\*It is the usual Service practice to manufacture the primary explosives in the Filling Factories in order to avoid the possible risks attendant on the use of 'outside' transport.

9. By varying the proportions of the reactants during the manufacture, mercury fulminate can be produced having different physical forms and bulk densities, which characteristics may be coupled with increased chemical stability, particularly when stored under adverse conditions. However, in spite of several attempts, satisfactory loading characteristics have not been achieved, and such materials have not been introduced into Service.

10. It is not hygroscopic, but in presence of water it tends to react with metals, with which it forms fulminates whilst liberating mercury. For this reason it cannot be used in aluminium-sheath detonators, and is usually protected from access of moisture in other detonators by applying a film of varnish to its free surface after pressing.

11. It is soluble in aqueous-alcoholic ammonia and in aqueous solutions of alkali, iodides and cyanides and of sodium thiosulphate (in the last instance with decomposition). The solubility of mercury fulminate in sodium thiosulphate allows analysis of the compound to be done or enables it to be destroyed in quantity. It is highly toxic.

12. It ignites with detonation at about 170°C after heating at 5°C/min, and it may detonate on prolonged heating at 100°C. It has an F of I of 10 and is very sensitive to friction. Its velocity of detonation is low (3000 to 4000 m/sec) but is rapidly attained, and consequently its effect is very local.

13. Although it has had a long life in military use, mercury fulminate is, in fact, an unsatisfactory Service explosive because it deteriorates rapidly when subjected to heat. Under dry heat at 175°F (80°C) it becomes completely insensitive (with decomposition) after 9 days; and under the hot-wet conditions of tropical storage it becomes insensitive after 3 to 4 months at 120°F (50°C). However, it has been used in detonators, alone or in admixture with 10% to 20% potassium chlorate, and as an ingredient of cap composition since before the First World War. Detonators employing it are still made in various forms, mainly commercial, and may have percussion or igniferous initiation (the latter being employed where the detonator follows an igniferous device). But its extreme sensitiveness imposes limitations on the quantity of fulminate which can safely be used in fuze detonators, which may be subjected to high accelerations in guns.

14. Mercury fulminate and mixtures based upon it are now being rapidly superseded in Service usage, and the amount of mercury fulminate now manufactured is extremely small.

#### Lead and silver azides

15. The explosive properties of the azides of lead, silver and mercury were first studied about 1890 by Curtius, who had been the earliest investigator of hydrazoic acid. He had believed hydrazoic acid to have the structure:

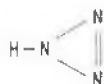

----- (2)

but which is now known, as a result of X-ray and other studies, to have the (canonical) structure

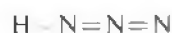

----- (3)

#### Types of lead azide

16. Lead azide,  $\text{Pb}(\text{N}_3)_2$ , is known in four polymorphic forms: alpha, beta, gamma and delta. The alpha form is that which usually occurs, although the presence of the beta form has been observed in the early stages of preparation of lead azide under conditions of poor mixing of the reactants (so that there is slow diffusion of reactants). It was at one time thought that the beta form was very sensitive — and even unstable — but it is now known that it is stable and that its sensitivity to impact and friction is not markedly different from that of the alpha form. Little is known of the properties of the recently discovered delta form, but the sensitiveness of the gamma form to impact is appreciably greater than that of the alpha form, although its sensitiveness to friction is lower. Admixture of Service (alpha) lead azide with 10% of either beta or gamma forms causes an increase in sensitiveness to both impact and friction.

#### Manufacturing equipment

17. In the manufacture of lead azide it is necessary that the equipment shall be so designed as to be capable of isolation from the operative, who is protected by a reinforced concrete wall fitted with either an arrangement of mirrors or small 'armourplate' glass windows through which the plant can be observed; this is necessary because lead azide is sensitive whether wet or dry and because, under some

conditions, it can detonate spontaneously. Accordingly, a standard equipment has been designed for use in the Filling Factories for the manufacture of Service lead azides and of any other primary explosives capable of being made by a double-decomposition reaction; it has been adopted in a number of other countries which have recognized its value in the production of materials of reproducible characteristics.

18. The principal item of the plant is a jacketed stainless-steel tilting pan, made to precise measurements and to a high standard of finish, and fitted with a stirrer also of precise dimensions and high finish. The jacket of the pan can be fed, through flexible connections, with either cold or hot water or steam as required. The speed of the stirrer affects the crystal-size of the product, and may be controlled either by a variable speed gear or by fitting to the drive motor an electronic controller which does not reduce the torque; a flexible drive between the motor (on the 'safe side' of the wall) and the stirrer allows the latter to tilt with the pan when necessary. The pan is normally tilted to a precise small angle to avoid the formation of a 'dead' volume below the stirrer.

#### *'Service' lead azide*

19. Filtered stock solutions of sodium azide (buffered by sodium carbonate to the correct pH) and of lead acetate are stored in stainless-steel tanks, whence the appropriate amounts are drawn into measuring vessels for each batch. A measured volume of water is placed in the pan, and gutta-percha tubes connected to the calibrated run-off jets of the two measuring vessels are set in the pan so as to give opposed flows just below the surface of the water. With the stirrer running and after a base solution of sodium carbonate has been added, the azide and acetate solutions are run in during a period of about an hour, the temperature of the mix being held below 25°C. Lead azide is precipitated in the form of free-flowing fine white crystals, which are washed by decantation with water several times in the pan, followed by a wash with alcohol. Finally the pan is tilted to enable the crystals to be washed onto a filter, which consists of a muslin bag in a gutter-percha filter-pot having a flat perforated base.

20. This pot, suitably covered, can then be removed to the drying room, where it is placed in a recessed hole in a suction box and fitted with a gutta-percha lid having a tubulure connected to a metered supply of clean dry air free from carbon dioxide. When the appropriate amount of air to dry the lead azide has been passed through it the pot is removed to the screening room, where (by remote control devices) it is tilted over a stainless-steel or silk vibrating screen through which almost all of the lead azide passes to a 6-way divider, so that 6 gutta-percha pots each receive loads of about 4 oz (113.4 g) for use in the filling shops. When these pots have been removed the screen can be tilted by remote control to empty out the small amount of coarse crystals remaining.

21. The liquors from the process, together with any waste lead azide, are treated with weak acetic acid and sodium nitrate; the nitrous acid arising from the latter reacts with hydrazoic acid in accordance with equation 4.



#### *'Service' lead azide properties*

22. The Service lead azide made by the preceding process is upwards of 97% pure (the remainder is mainly a basic lead carbonate employed as the nucleating agent) and is used, alone or with other compositions, in many detonators. It has a density of about 4.8 g/ml and a bulk density of about 1.9 g/ml. Its ignition temperature is about 330°C when heated at the rate of 5°C/min, and on explosion it decomposes (equation 5):



It has an F of I of about 15 to 20, but is more sensitive to friction than is mercury fulminate, though much less sensitive to pricking. Any pure or nearly pure crystalline lead azide becomes much more sensitive to friction when contaminated with grit (or with such other crystalline matter as RDX and tetryl) and is then hazardous to fill. The velocity of detonation of Service lead azide is 4500 m/sec at a pressed density of 3.8 g/ml.

23. Unlike mercury fulminate, Service lead azide does not readily become 'dead-pressed', does not deteriorate rapidly during hot dry storage and can be used in proximity to aluminium (para. 10). Lead azide is incompatible with copper or copper alloys at high relative humidities because it is slowly hydrolyzed by moisture, with evolution of hydrazoic acid which forms an extremely sensitive cuprous azide, which is then oxidized by air to an only slightly less sensitive cupric azide. This, in turn, is converted to basic cupric azide, which has about the same sensitiveness as lead azide. This 'copper azides' problem arises only at high levels of humidity (it was not observed in trials at 75% RH) but such conditions may arise in a sealed store in which some ingredient of the filling is not absolutely dry. It is therefore necessary to design stores having azide-filled detonators in such a way as to avoid the risk; this trouble is worthwhile, apart from safety considerations, because lead azide is a more efficient primary explosive on a weight basis than is mercury fulminate. The tinning of copper components has been found to afford good protection against attack by hydrazoic acid.

## RESTRICTED

24. Lead azide has been used in British Services since about 1925, when it was introduced as the main filling of 'composite' detonators, which had a topping of a mercury fulminate mixture to achieve the required degree of sensitiveness to functioning by needle stab or from flash, to both of which lead azide is less sensitive than is the fulminate mixture. Service lead azide continues to be the main filling of composite Service detonators, and because of its high detonation efficiency (due to its purity) it is used in quite small detonators (for example, 1.5 grain\* detonators) in combination with a suitable priming composition and an HE, usually CE.

25. It was stated in para. 17 that lead azide is capable of spontaneous detonation. So far as is known, this phenomenon occurs in practice only during the precipitation stage of manufacture. Over a lengthy period about 1 lot in 6000 of Service lead azide was lost at this stage, while the records show that half as many incidents occur at the sieving stage, and fifteen times as many incidents occur during filling (incidents which are generally attributed to mechanical or electrostatic causes). What is known is that spontaneous detonation at the precipitation stage does not occur if the manufacture is conducted in the presence of additions of hydrophilic colloids, for example, dextrin, methyl cellulose or carboxy-methyl cellulose.

### *Dextrinated lead azide, RD 1352*

26. In United States' military practice lead azide was adopted about 1930 as a primary explosive, but in the commercially-made 'dextrinated' form. Because certain stores of US design are made in United Kingdom Filling Factories for Service use, dextrinated lead azide has also been made in those Factories, under the designation RD 1352.

27. Dextrinated lead azide is in rounded aggregates having no observable crystal faces. It is white to buff in colour and contains only about 93% lead azide (the US specification permits as little as 91.5%) together with 4% basic lead azide and 3% dextrin and other impurities. Because of its lower purity it is a less efficient initiatory explosive than is Service lead azide.

28. Dextrinated lead azide is made in the United States by adding to a stirred solution of lead nitrate (heated to 71°C and containing dextrin to the extent of 5% of the weight of the lead salt) a solution of sodium azide containing 2.5% of caustic soda (calculated on the azide). In other respects the process resembles that for Service lead azide. The nodular product has an apparent bulk density of 1.5 g/ml and an absolute crystal density of 4.68 g/ml to 4.7 g/ml. Under equal pressing loads it gives a less dense product (for example, 3.28 g/ml at 20 000 lb/in<sup>2</sup>, 138 MN/m<sup>2</sup>) than does Service lead azide. It is somewhat hygroscopic; when exposed to 90% RH at 30°C it gains 0.8% in weight.

29. The dextrinated lead azide, RD 1352, made in this country for Service use is, compared with the American product, less vulnerable to changes in the source of supply of dextrin and has more consistent chemical and physical characteristics, including higher lead azide content and higher bulk density. These benefits result from the use during the precipitation stage of an anionic dispersing agent in addition to the dextrin.

### *Lead azide, RD 1343*

30. Lead azide, RD 1343, is a form of lead azide of high azide content and of free-flowing granular nature (having a bulk density of 1.6 g/ml and low hygroscopicity) which is prepared by carrying out the precipitation in presence of a proportion of sodium carboxymethyl-cellulose. Apart from increased safety in manufacture, it has advantages in the detonator filling processes and is now permissible for larger detonators; its slightly lower pressed density renders it unsuitable for the smaller British detonators in which, however, Service azide is effective. RD 1343, or the related RD 1333, is used in the smaller American Service detonators.

31. Lead azide can be co-precipitated with other substances (as inclusions and coatings), in presence of hydrophilic colloids, to give products for special purposes.

### *Silver azide, RD 1336*

32. Silver azide,  $A_6N_8$ , has received a good deal of attention because it is not subject to hydrolysis by moisture and is as effective a primary explosive as lead azide if made in appropriate crystal form. Only one crystalline form is known at ordinary temperatures; a beta form exists at high temperature. Silver azide is made by the same general technique as Service lead azide, starting from silver nitrate and sodium azide, but without carbonate nucleation; the precipitation is effected in a dilute ammoniacal medium in order to give rise to the necessary physical form of the product. It is incompatible with sulphur compounds (for example, antimony sulphide) and with tetrazene, and with some metals (for example, copper) when the possibility of exchange of metal radicals may result in the formation of a sensitive composition.

\* 1 grain = 64.798 mg

## CHAPTER 6

### Manufacture and properties of organic compounds used in the explosives industry

#### Benzene-chemistry nomenclature

1. In this Chapter as in the previous one, and for similar reasons, it is not proposed to discuss general chemistry. But as the first three high explosives to be described (in historical order) are all derivatives of benzene it is convenient to begin with a few remarks on the nomenclature used in benzene chemistry.
2. Benzene,  $C_6H_6$ , is an unsaturated ring-compound whose structure is usually depicted as in Fig. 1a or, more simply, in Fig. 1b.\* In this structure all the hydrogen atoms are equally reactive, but when one of them has been substituted by any radical, X, (Fig. 1c) the remaining hydrogen atoms have differing degrees of reactivity. Where one hydrogen atom has been substituted it is conventional, in relation to subsequent substitution, to describe this position in the ring by the number '1' and to number the

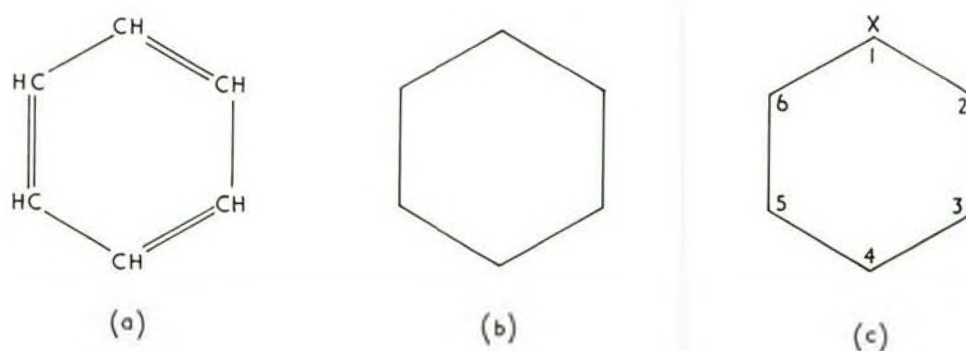
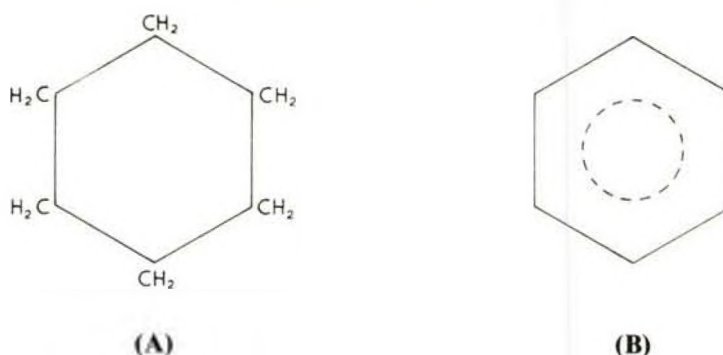

Fig. 1 Benzene-ring structure

remaining positions clockwise round the ring. Insofar as the uniform electron system of the original symmetrical benzene molecule has been disturbed by the presence of the substituent X, it will be apparent that positions 2 and 6 in Fig. 1c are equally reactive, as are positions 3 and 5, whilst position 4 is unique. With respect to the substituent X, positions 2 and 6 are said to be ortho- (o-) positions, positions 3 and 5 are meta- (m-) and position 4 para- (p-).

3. For present purposes interest is confined to the instances in which the substituent X is (i) hydroxyl, -OH; (ii) dimethylamino,  $-N(CH_3)_2$ ; and (iii) methyl,  $-CH_3$ . Compound (i) is phenol; (ii) is dimethylaniline; and compound (iii) is toluene. In all three examples the substituent radical is found to 'direct' a reagent (for example, nitric acid,  $HO.NO_2$ ) predominantly, though not exclusively, to the ortho- and para- positions. Since to achieve good explosive power it is desirable to have at least three nitro ( $-NO_2$ )



\*It is becoming conventional to reserve the symbol of Fig. 1b for cyclohexane, the structure of which is depicted in (A) above, and to use for benzene the symbol shown in (B) above; but for ease of reproduction Fig. 1b will be used in this Chapter to represent benzene.

radicals (or 'groups') attached to the carbon ring, this directive power is fortunate for there are three such sites of preferred reactivity (two ortho- and one para- positions). To the extent that, in the early stages of the nitration reaction, some substitution by a nitro-group may occur in a meta-position it will be seen that, as the reaction proceeds, there will be formation of a proportion of compounds in which two nitro-groups are adjacent (see Fig. 2). It is found in practice that one of these nitro-groups is caused by its proximity to the other to be highly reactive, so that it is readily removed by water \*, with consequent development of acidity; this is an undesirable state of affairs for a military explosive.

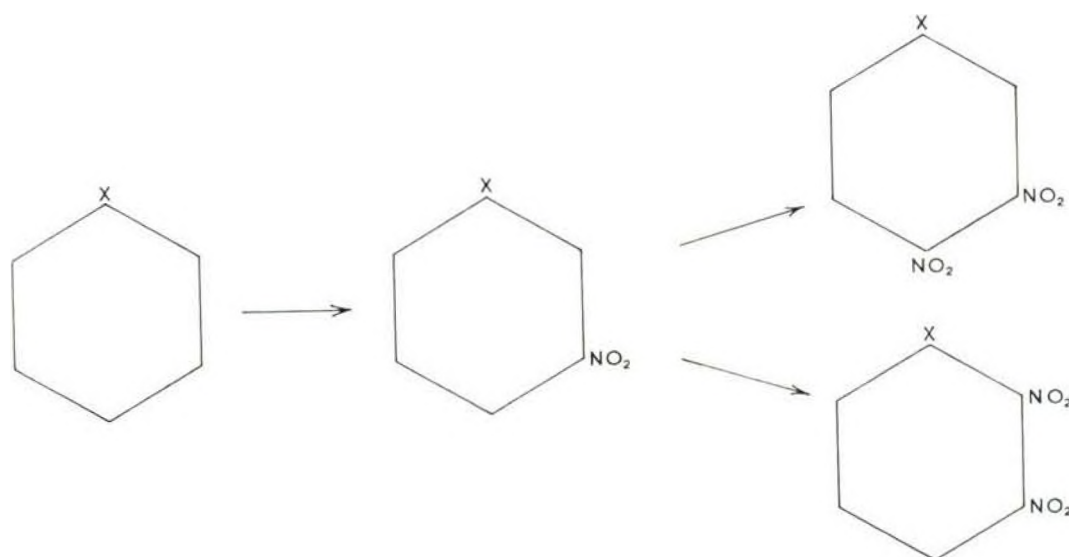

Fig. 2 Substitution by nitro groups

#### Phenol, picric acid and ammonium picrate

##### Phenol

4. Phenol was traditionally obtained as a product of the distillation of coal, being an important ingredient of coal tar from which it was isolated by fractional distillation. A certain amount is still so produced where coke ovens are operated, but a large proportion is now synthesized from benzene (by the hydrolysis of chlorobenzene or benzene sulphonic acid) or is obtained by the oxidation of cumene (isopropylbenzene), a process which also yields acetone. It is a white crystalline compound of mp 43°C and bp 182°C.

##### Picric acid

5. Because phenol is a solid it became customary to dissolve it in concentrated sulphuric acid at 90°C-100°C as a preliminary to its nitration; this results in the formation of phenol-disulphonic acid which reacts more smoothly than phenol in presence of nitric acid. The nitration may be operated to yield only 2:4-dinitrophenol by using only sufficient nitric acid for that purpose; but if picric acid (2:4:6-trinitrophenol) is required the phenol-sulphuric acid solution is added gradually to a nitrating acid containing a small excess of nitric acid over that theoretically required and the temperature is allowed to rise to 110°C-115°C. During the nitration the red colour of the phenolsulphonic acid solution changes to the yellow of picric acid. The picric acid is separated by filtration on a centrifuge after cooling. The theoretical yield is 243% that of the weight of phenol used, but it is not usual to obtain more than 220%. The excess of nitric acid employed must be kept small to avoid undue loss of picric acid in solution in the spent acid. The latter cannot be treated by the methods described in Chapter 5 because of the volatility of picric acid in hot acid vapours, and it is usually diluted with water before being poured to waste. The separated picric acid is washed with cold water on the centrifuge to free it from acid; this is done in stages, re-using the wash waters progressively on subsequent batches to minimize solubility losses.

6. The nitration and washing processes described in para. 5 are subject to many minor variations to suit the local acid economy, and these have small effects on the yield of picric acid. Particularly now

\* The exclusion of water vapour from military stores during their desired long life, important though it usually is, is very difficult. The water molecule is the smallest commonly met with in practice, and because of its low molecular weight relatively small amounts of water may cause extensive chemical degradation.

that relatively little picric acid is required the nitration process is conducted batchwise; but a continuous process was developed in this country in the 1914-1918 War, giving a yield of only 190%, however.

7. Because picric acid is a fairly strong acid and some of its salts are sensitive, many precautions are required in the design of plant for processing and handling it. Lead and lead paints must never be used and (at least after the nitration process) stainless steel, aluminium and even copper are preferable to iron as materials of construction for plant and equipment. Naked concrete floors should not be used, but should be covered with acid-resisting brick in wet areas and asphalt in dry areas.

8. Picric acid is a pale-yellow crystalline substance, melting at 122.5°C and commencing to sublime at higher temperatures. It is about 1% soluble in water at 20°C and nearly 7% soluble at 100°C. Its density is 1.81 g/ml and it can be pressed at about 2000 atmospheres, 202.64 MN/m<sup>2</sup>, (the maximum usually employed in practice for reasons of safety) to give blocks of density 1.67 g/ml. If a melt is slowly cooled, the density of the product is 1.66 g/ml.

9. Precautions should be taken against the inhalation of picric acid dust. Some workers prove skin-sensitive to picric acid, developing forms of dermatitis.

10. In the British Service at present the only use of picric acid is in the form of its ammonium salt, which is employed in some plastic propellants. Ammonium picrate is still used as a high explosive filling in some American stores, under the name 'Explosive D'.

#### *Ammonium picrate*

11. Ammonium picrate is made by suspending picric acid in hot water and neutralizing by addition of aqueous or gaseous ammonia. As the process proceeds the picric acid goes into solution as the salt, which crystallizes out on cooling. The crystals are separated by filtration, washed free from ammonia with cold water and dried. The colour of the crystals may vary from yellow to reddish-orange, and it has been shown that this depends on the pH of the solution during neutralisation; the yellow form results if ammonium carbonate is used instead of ammonia. It does not appear that the colour of the product is of importance from the standpoint of its use.

12. Ammonium picrate melts, with decomposition, at 265°C; its density is 1.72 g/ml and it may be compressed to a density of 1.59 g/ml at 50 000 lb/in<sup>2</sup> (344.75 MN/m<sup>2</sup>). Its solubility in water is about 1% at 20°C and about 42% at 100°C.

13. From the physiological standpoint, ammonium picrate requires the same precautions in handling as are employed for picric acid, that is, the use of dustmasks, frequent baths and changes of clothing.

### **Dimethylaniline and tetryl (Composition exploding—CE)**

#### *Dimethylaniline*

14. Dimethylaniline (DMA), the 'raw material' for tetryl, is nowadays made in industry by the catalytic vapour-phase dehydration of mixtures of aniline and methyl alcohol.



Aniline and methyl alcohol vapours are passed over a heated mixture of alumina and thoria; the precise composition of the most efficient catalyst mixture is something of a trade secret. The product is purified by distillation.

15. DMA is a pale yellow liquid of density 0.956 g/ml; mp 2.45°C; bp 194°C. It is about as toxic as aniline, and should not be allowed to come in contact with the skin, nor should the vapours be inhaled.

#### *Tetryl (CE)*

16. Tetryl, 2:4:6-trinitrophenylmethylnitramine, is made by the nitration of DMA which is first dissolved in concentrated sulphuric acid in which it forms the sulphate. When this solution is added to a strong nitrating acid mixture, the first stage is the rapid formation of 2:4-dinitrodimethylaniline (Fig. 3a) which is then attacked by more nitric acid at about 100°C, with elimination of a methyl group (in the transient form of methyl alcohol) and its replacement by a nitro-group (Fig. 3b), with simultaneous further nitration to tetryl (Fig. 3c):

17. The methyl alcohol formed is, of course, rapidly oxidized by excess nitric acid in the system, the acid being reduced to nitrous oxides which are led to absorption towers to form weak nitric acid (Chapter 5) for subsequent recovery. It is desirable that the nitrating acids should not contain too high a proportion of water, otherwise there is a tendency to form benzene-insoluble impurities (benzidine derivatives). In the British Service the nitration process (the result of development work before and during the 1939-1945 War) is performed continuously. The nitrator is, in effect, a stainless steel U-tube, one limb of which is conical and fitted with stirring gear and cooling coils. The DMA sulphate solution and mixed acid are metered into this limb *via* a pre-mixing vessel at 35°C, and the nitrous oxides

directed away from its wide upper end. The reaction mixture discharges from the other limb to a cooler and a stainless-steel gauze filter. The nitration temperature is about 100°C; lower temperatures conduce the increased formation of 'meta-nitrotetryl' (2:3:4:6-tetranitrophenylmethylnitramine) which at the nitration temperature of about 100°C is produced to the extent of less than 1%. The yield of crude tetryl (inclusive of such impurities) is 93% of theoretical.

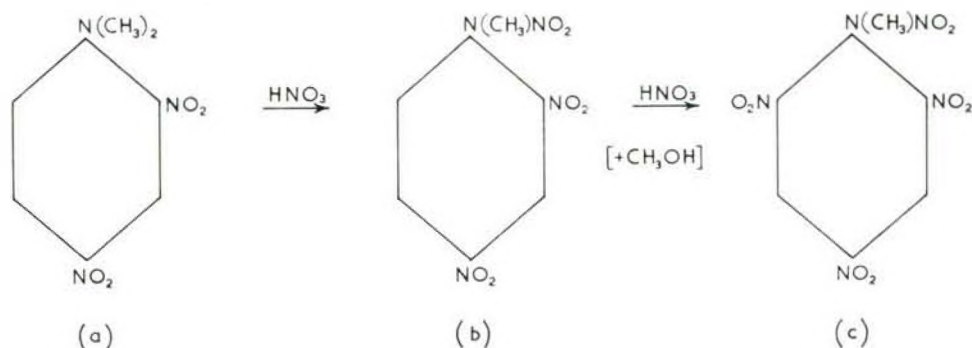

Fig. 3 Preparation of tetryl

18. The washed crude tetryl is first boiled with water, whereby the 'metanitrotetryl' is removed: the nitro group in the 3-position is hydrolyzed and substituted by a hydroxyl group, the resulting compound being soluble in water.

19. The boiled crude tetryl is next subjected to purification by recrystallization. In the early history of tetryl in the British Service this was done by two processes. Grade I tetryl was made by dissolving the crude tetryl in acetone, filtering and precipitating by adding water slowly while stirring. Grade II tetryl was made in a similar manner, but using nitric acid as the solvent; this method was adopted during the 1914-1918 War when acetone was in short supply. Both processes had the disadvantage that the pure tetryl was produced in the form of fine needle-shaped crystals, easily dispersed in air and not free-flowing in bulk, and thus not amenable to use in automatic presses. These difficulties were overcome by dissolving the tetryl in hot chlorobenzene, which was then removed by steam-distillation whilst stirring; the product was a rhombic crystal, free from dusty 'fines' and very suitable for the automatic pressing of most required sizes of pellets and not requiring inconveniently high pressure for making the larger pellets. It was found, however, that if acetone was used in place of chlorobenzene a softer, though still compact, crystal resulted which was more universally useful.

20. Tetryl is a pale-yellow crystalline substance of density 1.73 g/ml and capable of being pressed at 2000 atm (202.64 MN/m<sup>2</sup>) to give pellets of density 1.71 g/ml. It melts at 129.5°C, when decomposition can be seen in the melt. (In fact decomposition commences before melting, as is demonstrated by the Vacuum Stability Test (*q.v.*) which is done at 120°C.) It is stable to dilute mineral acids, but in solution in concentrated sulphuric acid the N-nitro group is split off to give free nitric acid, which is the basis of the quantitative analysis of the compound by the Lunge method. In the presence of dilute aqueous alkalis, tetryl is degraded to picric acid.

21. The same health precautions are required in the handling of tetryl as for picric acid and ammonium picrate (para. 9 and 13), but tetryl is even more prone to cause dermatitis and thus 'barrier creams' should be applied to the skin before commencing work.

### Toluene and 2:4:6-Trinitrotoluene (TNT)

#### Toluene

22. Toluene is a by-product of the distillation of coal, and consequently a certain amount is obtained from coke-ovens. It is also present in certain crude petroleum (for example, those obtained from Borneo). But probably the most important source today is the 'reforming' processes used in the petrochemical industry to convert aliphatic to aromatic hydrocarbons.

23. It is a clear colourless liquid, boiling at 110.6°C and having a melting point of -95°C; its density is 0.867 g/ml at 20°C.

#### 2:4:6 Trinitrotoluene (TNT)

24. The direct nitration of toluene to TNT is considered uneconomic on the large scale because of the dilution of the acids by the water produced. It is therefore customary to use the spent acid from the trinitration, after adjustment to a content of 7%  $\text{HNO}_3$  and 65%  $\text{H}_2\text{SO}_4$ , to nitrate toluene to mononitrotoluene (MNT); this was formerly carried out as a batch process, the reaction being performed

at 35°C-40°C, but a continuous process is now generally used. The MNT produced contains 4-5% meta-nitrotoluene, and the opportunity was often taken to subject it after water-washing to fractional distillation to separate the meta-content (boiling points: ortho- 220°C; meta- 232°C; para- 238°C), thus reducing the amount of 'meta- TNT' (also called 'unsymmetrical TNT') in the final product. The further nitration of the MNT was usually carried out in two stages ('dinitration' and 'trinitration') using successively stronger nitrating acid mixtures (that for the final stage generally containing free SO<sub>3</sub>) and higher temperatures.

25. Because of the importance of TNT its manufacture received much attention in all countries, and a good many variants on the above scheme were evolved. One, which was employed in this country by ICI Ltd, as Government agents in the 1939-45 War, was the 'sesqui-nitration' process: in this process toluene was nitrated in one stage to a product which was a mixture of mono- and dinitrotoluenes; the mixture was separated and nitrated to TNT in a second stage, using an anhydrous mixed acid.

26. During the 1914-1918 War a continuous process for the manufacture of TNT was developed in this country at the premises of Messrs Chance Ltd, at Oldbury and hence known as the Oldbury process. It is believed to have been the first effective continuous process and operated on the cocurrent-counter-current principle. That is, MNT was fed in at one end of a chain of nitrators and mixed acid at the other end and each nitrator was equipped with a separator from which the organic phase flowed to the next nitrator and the acid to the preceding nitrator, in each nitrator the acid and organic phases were flowing together, stirred into an 'emulsion', from inlet to outlet. There were 14 nitrators and 14 separators, operating at temperatures as given below:

Nos 1 and 2	40°C
3	70°C
4 to 13	100°C
14	90°C

The acid in the 'middle' of the system had the approximate composition:

HNO <sub>3</sub>	8 to 10%
NO <sub>2</sub>	1%
H <sub>2</sub> SO <sub>4</sub>	80 to 82%
H <sub>2</sub> O	11%

The spent acid from the first nitrator, into which MNT had been fed, had the composition:

HNO <sub>3</sub>	1%
NO <sub>2</sub>	4%
H <sub>2</sub> SO <sub>4</sub>	78 to 80%
H <sub>2</sub> O	14 to 16%
Organic matter	1 to 1.5%

27. Between the wars much work was done to perfect this process, and in the 1939-1945 War the Royal Ordnance Factories operated an improved version employing 16 nitrators and 16 separators, each equipped with a screw-lift to avoid the necessity of a change in height of the elements of the plant from end to end; the vessels were made of lead and were fitted with lids from which acid fume was ducted away. New anhydrous mixed acid was fed to nitrator No. 16 and additional nitric acid was fed in at certain points along the line of vessels (as 97% acid at nitrators Nos 14-9 and as 50% acid at Nos 8-3). The progress of the nitration was judged by the changes in setting point of samples of the organic phase taken from separators.

28. The great attraction of continuous processes for the manufacture of explosives, apart from savings in labour, is that for a given overall rate of production (say, tons per day) the amount of explosive in process in the plant at any time is much reduced. Accordingly, during and since the 1939-1945 War, such processes have been developed in other countries — by Meissner in Germany (1941), by Bofors in Sweden (1940-41) and by Chematur and Norsk Sprengstoffindustri in Sweden (1953). In the British Service the chief post-war development has been a simplification of the continuous plant. Essentially, this was achieved by building a long steel rectangular vessel with stirred nitrator compartments separated from unstirred separator compartments by partitions having systems of holes so disposed that there is a 'statistical' separation of the organic and acid phases as they flow in opposite directions.

29. However TNT is made, whether by batch or continuous processes, it will contain some impurities, notably those derived from early meta-nitration; these 'unsymmetrical' TNTs are 2:3:4- and 3:4:6-trinitrotoluenes, and they must be removed or they will give rise to an oily exudation which could be troublesome in filled munitions. There are also traces of tri- and tetra-nitromethane and of trinitrobenzoic acid. In the first stage of the purification of TNT it is washed with water at 78°C; this removes not only residual nitric and sulphuric acids but also traces of organic impurities. The molten

TNT is then treated at 78°C with a solution of sodium sulphite, buffered with boric acid to pH 8-9 to minimize attack on the symmetrical TNT; the unsymmetrical TNTs are removed as red, water-soluble, sodium salts of sulphonic acids. The reaction is shown in Fig. 4.

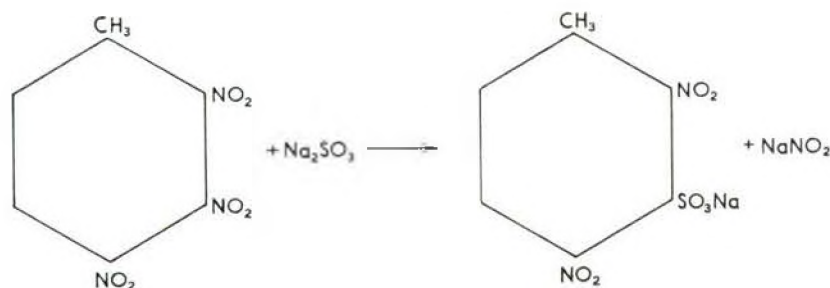

Fig. 4 The action of sodium sulphite solution on molten TNT

30. The red liquors are usually discarded (in this country, TNT factories were built on the coast so that such liquors could be ducted to the sea). The purified TNT, now of setting point about 80.5°C, is again washed with hot water and passed to the steam-jacketed trough of a flaking machine.

31. Pure symmetrical TNT is a pale-yellow crystalline material of mp 80.65°C and density 1.654 g/ml. It decomposes slowly at 180°C-200°C, with evolution of gas and lowering of its setting point; at 240°C it ignites after some time (the ignition temperature, as conventionally measured, is about 315°C). It darkens somewhat on exposure to light but is very stable and non-reactive except under alkaline conditions. When cast, as it usually is for fillings, its density is about 1.58 g/ml.

32. From the physiological standpoint, care should be taken to avoid the inhalation of vapours from hot TNT and the ingestion of TNT dust; like many aromatic compounds TNT tends to settle in the liver with bad effects.

33. Before leaving the subject of TNT manufacture some reference should be made to White Compound, the possible occurrence of which, especially in the continuous process, might be a cause of accidents. It was first observed to appear as a by-product in certain stages of the Oldbury process, and again in the improved process used in the 1939-1945 War, after the plant had been running for some 40 hours. If allowed to accumulate it might ignite; it was also found that it could form sensitive lead salts. It has been noted in para. 29 that a trace impurity of crude TNT is trinitrobenzoic acid, the precursor of which is trinitrobenzaldehyde, and it was shown that the latter could be condensed to give White Compound in presence of sulphuric acid. The problem was minimized by running the plant at full capacity, when the small amount of White Compound formed passed on into the purification process where it was safely removed. White Compound is a complex compound of acidic character.

#### Resorcinol, 2:4- and 4:6-Dinitroresorcinols and 2:4:6-Trinitroresorcinol (Styphnic acid)

##### Resorcinol

34. Resorcinol is made in industry by the fusion with caustic soda of the sodium salt of m-benzenedisulphonic acid:

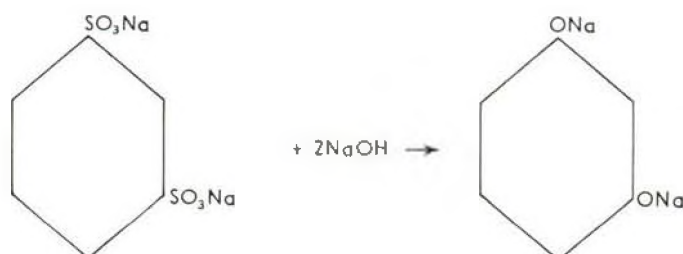

Fig. 5 Preparation of resorcinol

The melt is dissolved in water and acidified to liberate the resorcinol.

*2:4-Dinitroresorcinol*

35. 2:4-dinitroresorcinol is made by treating resorcinol in aqueous solution with nitrous acid ( $\text{NaNO}_2 + \text{H}_2\text{SO}_4$ ), when 2:4-dinitrosoresorcinol is precipitated. Sodium bicarbonate is added to the aqueous suspension to adjust the pH and 30% hydrogen peroxide is then added slowly until a small excess is present, effecting the oxidation of the dinitroso- to the dinitro-compound, which is filtered off and recrystallized from hot water, using a small quantity of animal charcoal to remove traces of tarry matter. The oxidation of the dinitroso-compound may also be effected by the use of 50% nitric acid, but this method is not favoured because of the risk of the formation of a proportion of styphnic acid.

*4:6-Dinitroresorcinol*

36. 4:6-dinitroresorcinol is made by the direct nitration of resorcinol using concentrated nitric acid at  $-10^\circ\text{C}$  to  $-20^\circ\text{C}$  (by adding solid  $\text{CO}_2$  to the acid together with the resorcinol). The nitration mixture is then drowned in ice-water and the nitro-compound filtered off and purified by dissolving it in caustic soda solution and adding this solution to hot dilute sulphuric acid. If necessary, it may be further purified by recrystallization from water, as in para. 35.

If 4:6-dinitroresorcinol of particularly high purity is required, it may conveniently be made by adding 1:3-diacetoxybenzene to cold fuming nitric acid, preferably at a temperature of  $-35^\circ\text{C}$  to  $-40^\circ\text{C}$  obtained by adding solid  $\text{CO}_2$  to the reaction mixture. Addition complete, the solution is aged for 5 minutes then added to crushed ice to precipitate the intermediate 1:3-diacetoxy-4:6-dinitrobenzene. This product is filtered off, washed with water, then hydrolyzed in hot 18% hydrochloric acid. After cooling, the solid is filtered off and dissolved in 8% sodium hydroxide solution; this solution is acidified with acetic acid to pH 4.4 to precipitate 4:6-dinitroresorcinol (yield 60%). Acidification of the filtrate to pH 0.6 causes the precipitation of by-product styphnic acid (yield 7%).

*2:4:6-Trinitroresorcinol (Styphnic acid)*

37. 2:4:6-Trinitroresorcinol (Styphnic acid) is the product of nitration of resorcinol in a mixed nitrating acid ( $\text{HNO}_3 + \text{H}_2\text{SO}_4$ ) at about  $60^\circ\text{C}$ . It is almost insoluble in the acid and is filtered off, washed and recrystallized from hot water, using animal charcoal to remove tarry by-products which, under the conditions of nitration, tend to be present in rather greater quantity (say 0.2%) than with the dinitro-compounds described above. A more recent process has been developed by the Explosives Research and Development Establishment and adopted by the Royal Ordnance Factories. Resorcinol is treated with sodium nitrite in dilute nitric acid to give 2:4-dinitrosoresorcinol which is then added as a slurry to hot concentrated nitric acid, in which it undergoes oxidation and nitration to yield styphnic acid with about 90% yield.

**Phloroglucinol and Trinitrophenol***Phloroglucinol*

38. Phloroglucinol, 1:3:5-trihydroxybenzene, cannot be made in a manner analogous to that employed for resorcinol because the corresponding benzenetrisulphonic acid cannot readily be made. It is therefore found more convenient in industry to start with TNT, which is first oxidized to trinitrobenzoic acid (using chromic acid in sulphuric acid), which is decarboxylated (by boiling in water), reduced to triaminobenzene (using iron and hydrochloric acid) and hydrolyzed (in presence of more hydrochloric acid), see Fig. 6.

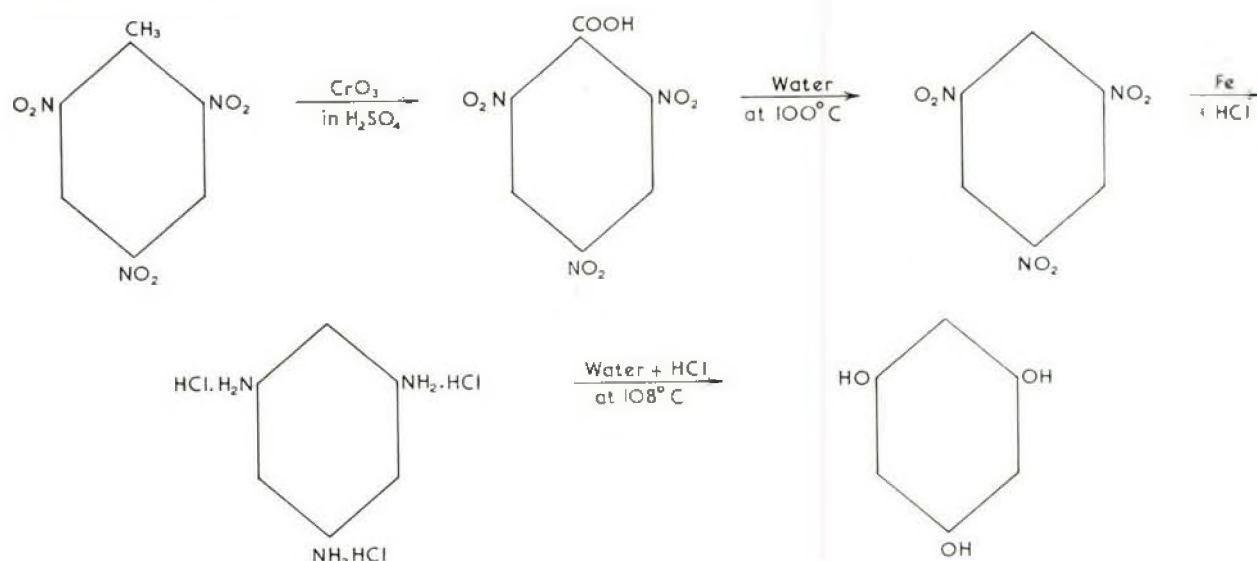

Fig. 6 Preparation of phloroglucinol

39. The phloroglucinol must be extracted from solution by a solvent immiscible with water and then purified. It is, of course, quite costly and it is fortunate that the Service requirement for it is small.

*Trinitrochloroglucinol*

40. 2:4:6-trinitrochloroglucinol can be made by the direct nitration of phloroglucinol in mixed acid, but purer products are obtained either by nitration of triacetylphloroglucinol in concentrated nitric acid at 0°C (see para. 36), the acetyl groups are removed by hydrolysis when the nitration mixture is poured into ice-water, or by making trinitrosophloroglucinol (see para. 35) and oxidizing this using 50% nitric acid. The trinitro-compound is very soluble in water.

**1:3-Diamino- and 1:3:5-Triamino- 2:4:6-Trinitrobenzene**

41. Missiles with a long time of flight may be subject to appreciable aerodynamic heating. It is therefore desirable that any explosive filling used in them shall be as resistant as possible to high temperatures, and DATB and TATB are materials which have been under active consideration for such fillings. They were both made in this country about 1930 in the course of the attempts to synthesize hexanitrobenzene (see Chapter 2). Both are less sensitive but somewhat more powerful, than TNT.

*1:3-Diamino-2:4:6-trinitrobenzene (DATB)*

42. Dinitrobenzene is reduced, using iron and hydrochloric acid, to m-phenylenediamine, which is nitrated in an anhydrous mixed acid at a high temperature (ca 140°C) under reflux to yield DATB. An alternative route starts from m-nitraniline, which is nitrated to 2:3:4:6-tetranitraniline; this is dissolved in boiling methyl alcohol to give 2:4:6-trinitro-3-methoxyaniline, which is converted to (insoluble) DATB of good crystal form when ammonium acetate is added to the boiling alcoholic solution.

43. DATB is a lemon-yellow crystalline substance of mp 286°C and density 1.837 g/ml. It is fairly stable up to within a little of its melting point, decomposing at a rate of less than 1% per hour at 260°C, but it transforms to a crystal form of lower density at 216°C, which temperature therefore represents its upper limit of utility.

*1:3:5-Triamino-2:4:6-trinitrobenzene (TATB)*

44. TATB is most readily prepared from aniline by the following scheme:

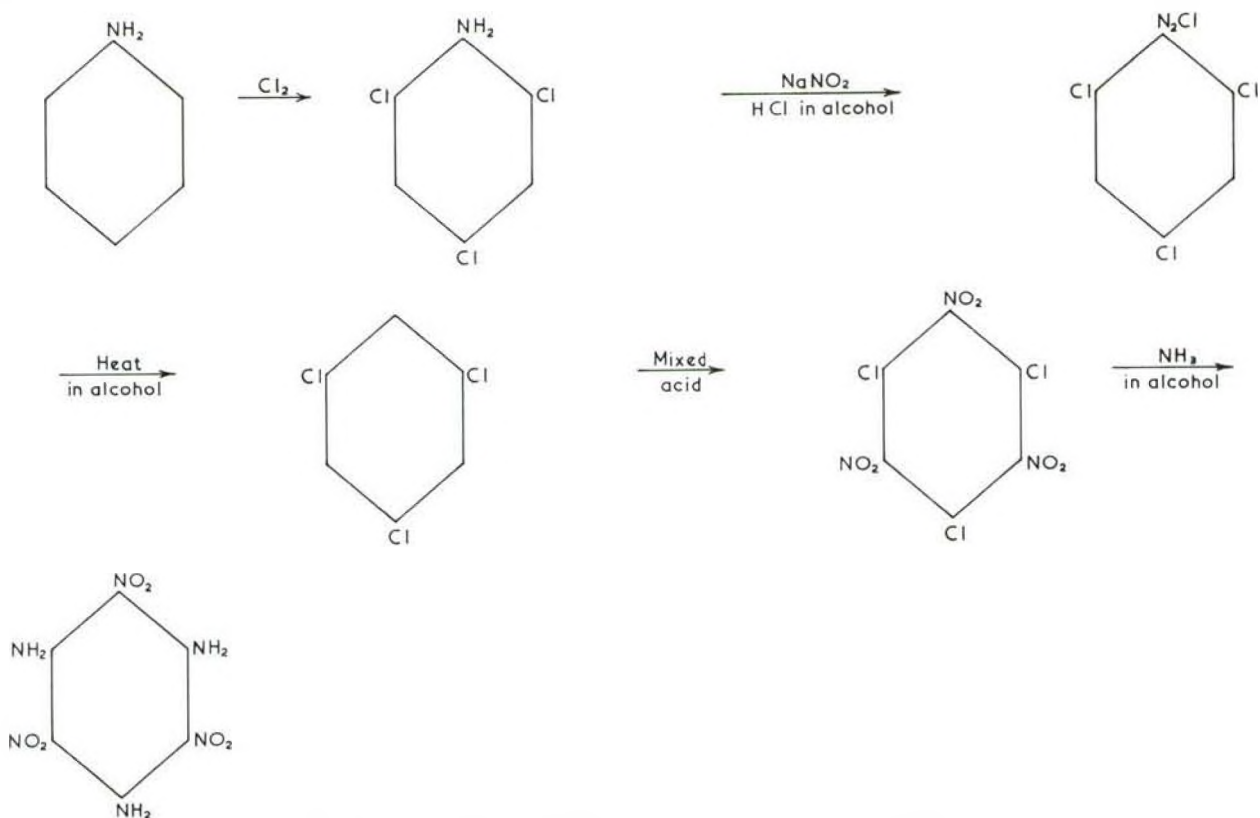

Fig. 7 Preparation of triaminotrinitrobenzene (TATB)

45. TATB melts at about 340°C (some authorities quote 450°C) and has a density of 1.938 g/ml. It is a yellow-brown substance which decomposes rapidly just below its melting point, but has excellent thermal stability in the range 260°C - 290°C, which represents the upper temperature limit at which it may be used.

#### Hexanitrodiphenylamine

46. This explosive, which was used by the Germans in the First World War in pressed form as a torpedo-warhead filling and in the 1939-45 War in admixture with TNT as a bomb filling, was never adopted by the British Services because of its physiological properties (it is a powerful vesicant and causes severe dermatitis) and because of the risks of the formation of sensitive salts (the amino-hydrogen atom is acidic in reaction). However, it is very stable, has a melting point of 244°C and a density of 1.65 g/ml and is more brisant than TNT. It is best made by the condensation of 2:4-dinitrochlorobenzene with aniline to yield 2:4-dinitrodiphenylamine which is then nitrated in hot mixed acid to 2:4:6:2':4':6'-hexanitrodiphenylamine.

#### Hexamine, RDX and HMX

##### Hexamine

47. Hexamine, or more precisely hexamethylenetetramine, is the product of condensation of formaldehyde and ammonia. It is used in industry as a raw material for certain synthetic resins, but for military purposes is made in the Royal Ordnance Factories (since ammonia is imported into them, anyhow, as the source of nitric acid). The required formaldehyde is derived from synthetic methyl alcohol, which is oxidized to the aldehyde by passing its vapour, mixed with air, over a silver catalyst gauze. The formaldehyde vapour is condensed from the gases as a 40% aqueous solution, which is treated with gaseous ammonia in a well-cooled reaction vessel to yield hexamine, which crystallizes out and is filtered off on a centrifuge, washed free from by-products (ammonium formate, etc) using a little cold water, and dried. The reaction between formaldehyde and ammonia may be written:



Hexamine is a white crystalline substance which sublimates at 280°C and has a density of 1.33 g/ml. Its structure is commonly written as in Fig. 8a, but it is more nearly that of an equilateral tetrahedron with nitrogen atoms at the apices and  $-\text{CH}_2-$  groups in the centre of each edge (Fig. 8b) except that, in fact, the  $-\text{CH}_2-$  groups are offset from the edges (in the manner indicated for one group in Fig. 8b) to accommodate the natural valency angle. (The spatial configuration can most nearly be constructed by bringing together four paper equilateral 'hexagons' so that all their edges are paired.)

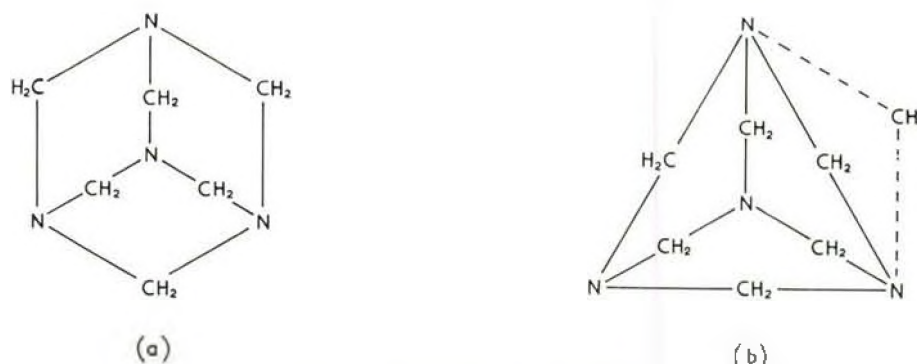

Fig. 8 Structure of hexamine

##### RDX (Cyclo-trimethylenetrinitramine) prepared by Woolwich process

48. From the standpoint of initiation of reaction of hexamine with nitric acid, it will be seen from either Fig. 8a or b that the hexamine molecule is completely symmetrical and that all points of attack are equal. Isolating one nitrogen atom for consideration (say the topmost one of Fig. 8a), it is apparent that attack by nitric acid might proceed as in Fig. 9.

49. The system in Fig. 9a is transformed to that in Fig. 9b by a process which may be regarded as 'nitrolysis' (cf. 'hydrolysis', where the reagent is water, H.OH). If this nitrolysis process occurs at each of the three nitrogen atoms in the outer hexagonal ring of Fig. 8a the end-products will be as given in Fig. 10.

50. Fig. 9 and 10 constitute a highly simplified representation of the reaction between hexamine and nitric acid, and there is an extensive literature on the course of the reaction. But Fig. 10a is the (planar) structure of the RDX molecule.

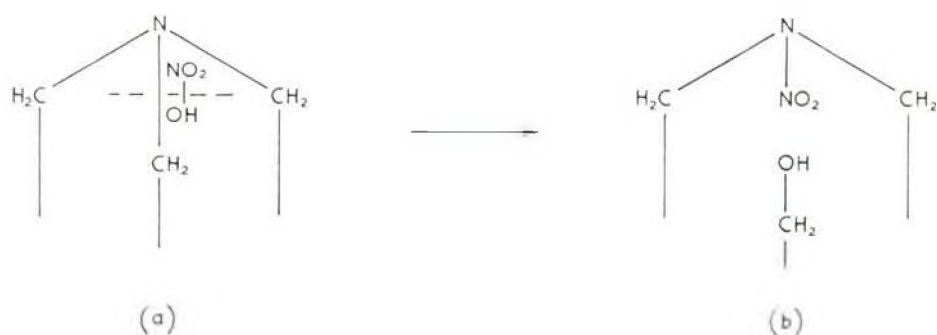

Fig. 9 Initial reaction between hexamine and nitric acid

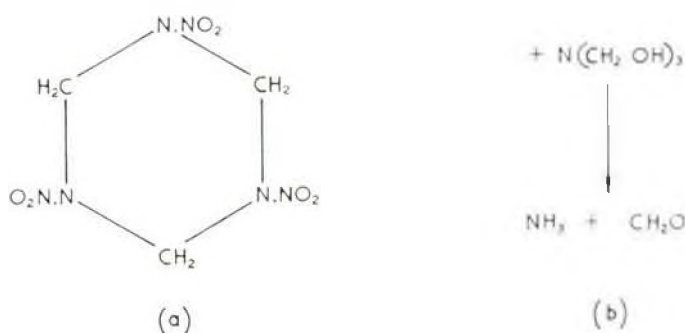

Fig. 10 Further reaction of hexamine with nitric acid

51. If 1 part of hexamine is added gradually to 10 parts of concentrated (97%-99%) nitric acid with stirring and cooling, to keep the temperature below 25°C, a small proportion of the RDX formed will crystallize out on cooling to, say, 10°C; some carbon dioxide and nitrogen are evolved. If the vessel is left without cooling, the temperature will gradually rise and a violent reaction (fume-off) will set in; this is due to the oxidation of the formaldehyde (Fig. 10b). If, instead of leaving the vessel, its contents are poured onto, say 50-100 parts of crushed ice, all the RDX will be precipitated; but if this mixture is left to stand, it too will heat up due to oxidation of the free formaldehyde (whose presence is obvious by its smell); this may not happen for several hours and, when it does, reaction may be so energetic as to cause almost all the mixture to froth over the lip of the vessel.

52. Clearly, then, a satisfactory process for the manufacture of RDX should involve continuous solution of hexamine in nitric acid followed by continuous oxidation of the formaldehyde formed. In fact, it was found that if the solution of hexamine in nitric acid was added gradually, together with an almost equal weight of water, to 55% nitric acid solution at 75°C, the oxidation of formaldehyde proceeded steadily in a controlled manner and the RDX was precipitated in a crystalline state.

53. The 'Woolwich', or 'nitrolysis', process for the production of RDX (used in the Royal Ordnance Factories and in the USA during the 1939-45 War) was based on the foregoing process. Hexamine is continuously weighed into a screw-feed which delivers it to a rectangular stainless-steel nitrating vessel which is divided by suitable baffle-plates into four sections, the first of which is fitted with a triple cooling coil and the third and fourth with single coils; the second section is narrower and is separated from the first by a plate under which the reaction mixture flows and it leads to the third by a weir, whilst the third is separated from the fourth by a plate under which the reaction mixture flows. Nitric acid of 97%-99% strength is metered into the first compartment along with the hexamine. All three cooled sections are stirred and the temperature is not allowed to exceed 35°C; the nitrator is fitted with drowning valves so that it can be once emptied if the temperature should get out of control or if 'brown fume' should appear in a sight glass. The reaction mixture passes from the top of the fourth compartment to the diluter, which is another, but larger, rectangular stainless-steel vessel divided into four compartments by baffle plates round which the reaction mixture flows; each compartment is stirred and the temperature is controlled by sprays of water playing on the walls of the vessel. As the mixture from the nitrator enters the diluter it is joined by a metered flow of water adjusted to ensure that the concentration of the acid leaving the diluter is 55%. The oxidation of free formaldehyde in the diluter results in the degradation of a corresponding amount of nitric acid to nitrous oxides which are ducted away to absorption towers and there recovered as 55% nitric acid (see Chapter 5). The effluent from the fourth compartment of the diluter passes through a stainless-steel cooler, to a continuous stainless-steel filter from which the RDX is passed (moist with 15%-20% of 55% HNO<sub>3</sub>) to a second continuous filter on which it is washed with cold water. [The continuous filters are an adaptation of the Dorr Oliver classifier, used in certain branches of mineral ore processing, and their design is such that the explosive

being filtered is not subject to friction by moving parts.] The washed RDX may either be milled and boiled in water to reduce the occluded acidity to a level acceptable for many purposes or may be crystallized, using cyclohexanone. The yield of RDX is about 70%-75% of the theoretical yield.

*RDX (Cyclo-trimethylenetrinitramine) prepared by Bachmann process*

54. If one molecule of formaldehyde could be caused to react with a molecule of ammonium nitrate with elimination of a molecule of water, RDX should be formed (equation 3).

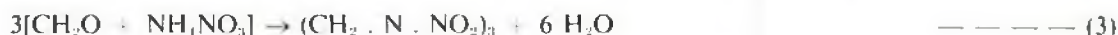

It was, in fact, found that this reaction would occur in a hot acetic anhydride medium. However, the discovery was not widely developed because it was soon combined with the observation that both formaldehyde and ammonium nitrate are present in the 'nitrolysis' reaction mixture (see Fig. 10b). It occurred to Bachmann in the USA in 1941 that if hexamine could be brought into reaction with nitric acid in the presence of acetic anhydride and additional ammonium nitrate an increased yield of RDX should result. In fact, conditions were found under which such reaction could be carried out, either batchwise or continuously, to give yields of 'RDX' of about 75% (calculated on the utilization of all six carbon atoms in the hexamine molecule). The process was thus very attractive from the viewpoint of the consumption of hexamine per tonne of product. However, that product was not pure RDX but contained appreciable (*ca.* 10%) quantities of HMX. Further, the control of the addition of reactants to the process had to be very precise to avoid either the formation of a lower yield of a product much richer in HMX or the complete disappearance of RDX and HMX and the production of soluble by-products, some of them the acetyl derivatives of by-products found in the nitrolysis process.

*Properties of RDX*

55. Pure RDX melts at 204°C and has a density of 1.805 g/ml. It explodes on heating to 226°C. It is of the same order of chemical stability as TNT, but is considerably more powerful; it is of about the same power as PETN which, however, is less stable and more sensitive to some mechanical stimuli.

If RDX dust is ingested into the human system spasms are induced.

RDX can be synthesized by other methods than those described above.

*HMX (Cyclo-tetramethylenetrinitramine)*

56. It is apparent from what has been said in para. 54 that the method for the manufacture of HMX is basically that of Bachmann, suitably modified to ensure that the product is as rich as possible in HMX and as 'lean' as possible in RDX. In fact, the process is best conducted batchwise to simplify control and thus minimize by-product formation. It is also found desirable to add to the reaction system a certain amount of extra formaldehyde (as paraform), whereby the proportion of HMX is increased. A mixture of acetic acid and acetic anhydride is made in a stirred jacketed pan (provided with fume extraction) and is raised to 45°C, when solutions of hexamine in acetic acid and of ammonium nitrate in nitric acid are added simultaneously and equivalently, with intermediate addition of paraform. After a period of stirring at 45°C, water is added to reduce the concentration of acetic acid to 70%, and the temperature is raised to about 100°C for several hours to hydrolyze by-products and take a considerable part of the RDX into solution (it is more soluble in most solvents than is HMX). The mixture is then filtered and the product washed with portions of cold water. At this stage the product is mainly in the  $\alpha$ -modification (see below) and is in fine crystals, which thus retain a high proportion of liquid. The product is boiled with water, during which traces of the  $\gamma$ -modification are converted to the  $\alpha$ -form, more by-products are broken down and more formaldehyde is evolved; by filtering hot at this point more RDX is removed in solution and the residual HMX contains less than 1% RDX. The HMX is then subjected to a recrystallization process, using suitable solvents and techniques to remove the last of the RDX and to ensure the conversion of the HMX to the  $\beta$ -form in suitable crystal size.

57. The acid filtrate from the initial reaction mixture contains nitric acid, ammonium salts, formaldehyde, formic acid, etc, besides a large proportion of valuable acetic acid, but processes have been devised for the recovery of the last with an efficiency of 95%.

58. HMX melts at 278°C. It exists in at least four crystalline modifications, or polymorphs —  $\alpha$ ,  $\beta$ ,  $\gamma$  and  $\delta$ . Of these the first three can exist at room temperature but the  $\delta$  form transforms readily. The  $\beta$ -form is the most stable and the least sensitive; its stability is comparable with that of RDX, and for Service use the specification for HMX calls for a microscopic examination to ensure the absence of polymorphs other than  $\beta$ . The densities of the polymorphs are:

$\alpha$  1.847 g/ml;  $\beta$  1.905 g/ml;  $\gamma$  1.74 g/ml;  $\delta$  1.80 g/ml.

**Pentaerythritol (PE) and Pentaerythritol Tetranitrate (PETN)**

*Pentaerythritol (PE)*

59. In many compounds containing the =C:O group, which is characteristic of ketones and aldehydes, the hydrogen atoms attached to an adjacent carbon atom are more reactive than they would otherwise be.

Again, two molecules of an aldehyde react in aqueous alkaline solution (Cannizzaro reaction) as given in equation 4.

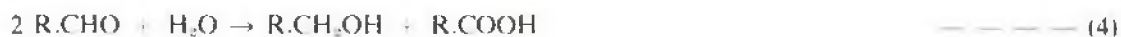

These two facts account for the formation of pentaerythritol (PE) by the reaction of one molecule of acetaldehyde with four molecules of formaldehyde in aqueous solution in presence of lime (equation 5).



In practice, acetaldehyde is added slowly, under the surface, to a suspension of lime and paraform in water at 30°C-35°C. When the reaction is complete, the calcium is precipitated by adding sulphuric acid, the calcium sulphate filtered off and the filtrate evaporated to yield crude PE which must be recrystallized from water to eliminate dipentaerythritol. Pure PE melts at 261°C-262°C.

*Pentaerythritol tetranitrate (PETN)*

60. PETN is best made by the addition of PE to 98%-99% nitric acid (5-6 parts) at 15°C-20°C in a stainless-steel nitrator fitted with a stirrer and cooling coil fed with refrigerant. The mixture is then diluted without allowing the temperature to rise, to reduce the acid concentration to 30%, and the PETN is filtered off. By this procedure, by-products are retained in solution. The crude crystalline PETN is washed and recrystallized, using acetone. The yield is about 97%.

61. It is undesirable to use a mixed-acid nitration process since the presence of sulphuric acid tends to cause the precipitation of impurities in the PETN which may adversely affect its subsequent stability.

62. A continuous nitration process can be employed but it is difficult to avoid the coating of the cooling surfaces with PETN.

63. PETN is a white crystalline substance melting at 141°C and having a density of 1.765 g/ml. It explodes on heating to 205°C. Its chemical stability is good when it is pure and dry; this is probably due to its symmetrical structure.

64. The physiological effect of PETN on the human system is similar to that of all other nitric esters (to produce vasodilation) but the effects are small as its solubility is low.

**Cellulose and Nitrocelluloses**

*Cellulose*

65. Cellulose is a natural polymer of vegetable origin. The degree of polymerization, or 'chain length', varies from source to source and for military purposes only the celluloses derived from cotton and certain woods have been of interest; these have molecular weights varying from 300 000 to 500 000.

66. Cotton fibre is almost pure cellulose, but the cellulose fibres in wood are associated with a complex resin known as lignin and with 'hemicelluloses' which must be removed by treatment under pressure with hot aqueous sulphite or alkaline sulphide solutions, when a cellulose of purity comparable with that of cotton may be obtained. The chemical structure of cellulose is represented in Fig. 11.

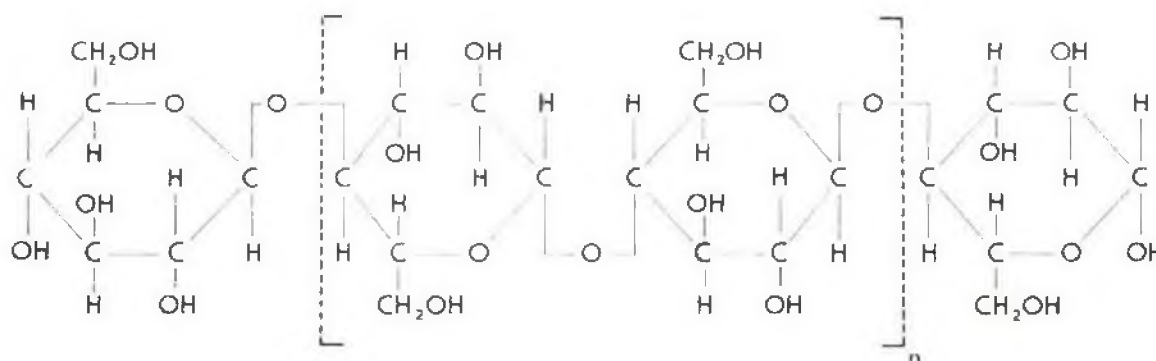

**Fig. 11 Chemical structure of cellulose**

67. Each of the hexagonal rings with its appended groups is known as an anhydroglucose unit. The value of 'n' corresponds to the length of the cellulose chain, that is the degree of polymerization and therefore the (average) molecular weight.

68. Each anhydroglucose unit contains three hydroxyl groups and if each of these could be esterified by a nitric acid molecule, true trinitrocellulose with a nitrogen-content of 14.14% would be obtained. But, because of its complex physical (as well as polymeric) structure, cellulose is not readily so completely esterified, or 'nitrated', although a nitrogen-content of about 14% can be obtained. In practice, depending on the composition of the mixed acid employed and to some extent on other conditions of nitration, nitrocelluloses of varying nitrogen-content up to about 13.4% are regularly made, and in them it may be supposed, from all their behaviour, that the nitrate groups are randomly distributed throughout the cellulose chain. The mononitrate would correspond to a nitrogen-content of 6.75% and the dinitrate to one of 11.11%.
69. Because of the great technological importance of cellulose and its derivatives, there is a vast literature on its chemistry and its physical and molecular structure, but for present purposes it will suffice to note that cellulose may be degraded (that is, its chain length, and therefore molecular weight reduced) by the action of hydrolyzing or oxidizing agents or (though to a lesser degree) by mechanical means.
70. It has been said above that both cotton and wood celluloses are used in the production of military nitrocelluloses. In the British Service it used to be preferred to employ purified cotton waste, but owing to the recent changes in the economics of the textile industry it is now becoming necessary to employ cotton linters, that is, short fibres in a fluffy form which are picked from the cotton seed after removal of the long fibres for textile use. When wood cellulose, derived from wood such as spruce, was introduced into the Service it was imported into the country in the form of sheets of chemical wood pulp, from which paper was made. Originally the paper was then shredded so that it could more readily be used in the same nitration plant as had been employed for cotton; later it became the practice to make up the paper into scrolls (by winding together one plain and one corrugated sheet) of a size which would enable four scrolls to fit into the nitration vessel.

#### *Nitrocelluloses\**

71. Partly by varying the source of the cellulose employed, but more by varying the composition of the nitrating acid and the time and temperature of nitration, nitrocelluloses of a range of nitrogen-content from 8% to 13.4% may conveniently be made. The lower members of the range are too heterogeneous to be of utility; those of 10.5% to 12% N are primarily of industrial interest and are used for the manufacture of lacquers and celluloids. As the nitrogen content increases the nitrocelluloses are characterized by an increasing tendency to be insoluble in alcohol or mixtures of ether and alcohol. Thus, nitrocellulose (NC) of 10% to 10.5% N is soluble (to form a gel) in alcohol, while that of 11% to 12.3% N is insoluble in alcohol but soluble in ether alcohol; NC of 12.6% to 12.9% N is only partly soluble in ether/alcohol and that of more than 12.9% N is insoluble in that solvent. (These classifications are only broadly valid; a certain amount depends on the chain-length of the NC as well as on its nitrogen-content.) All nitrocelluloses are soluble in acetone.
72. In the British Service interest is mainly concentrated on three types of NC which are made in the Royal Ordnance Factories, namely those of 12.2%  $\pm$  0.1% N, 12.6%  $\pm$  0.1% N and 13.1%  $\pm$  0.1% N. The last is often referred to as guncotton and is employed in Land Service cordites; it is very similar to the product made by Abel about 1870 (see Chapter 2), though more stable, of course. The 12.6% N product is the basis of smokeless powders and is also used in the manufacture of cast double-base propellants. The 12.2% N nitrocellulose is employed for the manufacture of solventless and semi-solventless cordites.
73. The nature and purity of the cellulose to be employed having been defined in Service specifications, control over the nitrogen content of the NC to be produced depends primarily on the composition of the mixed acid to be used in nitration. Too high a content of nitric acid increases the risk of ignition of the cellulose during nitration, and in practice the weight ratio of sulphuric acid to nitric acid lies in the range 2.5 to 3; a suitable value in this range having been chosen, the rest depends on the water content of the acid. Broadly, a variation of 0.5% in the nitric acid content results in a corresponding variation of 0.1% to 0.2% in the nitrogen content of the NC.
74. Many processes for the nitration of cellulose have been devised, but in the British Service only two are in use, namely the 'displacement' and the 'mechanical' processes.

#### *Displacement process for nitrating cellulose*

75. In the displacement process the nitrating vessel is a shallow earthenware pan (Fig. 12), originally circular but more recently square with rounded corners, the conical bottom of which slopes to a hole fitted with a three-way plug-cock so that the pan may be connected to a nitrating acid feed line, or to a

\* It should be noted that nitrocelluloses are, in fact, not nitrocompounds but nitrate esters in which the NO<sub>2</sub> groups are linked to carbon not directly but through oxygen atoms, thus: C — O — NO<sub>2</sub>.

spent-acid disposal line or to waste. Across the full width of the pan a loose perforated earthenware plate lies at the bottom. The pan is covered with an aluminium hood (connected to an exhaust line) for the duration of the early stages of the process. The pan is filled with nitrating acid, preconditioned to a temperature between 17°C and 21°C, and then the cellulose is 'dipped' through a door in the hood; if it is cotton, *ca* 13.6 kg (30 lb), or shredded paper, *ca* 11.8 kg (26 lb), it is added in portions, using an aluminium fork; if it is scroled paper, four scrolls *ca* 3.9 kg (8½ lb) each are immersed. The weight ratio of acid to cellulose is 30 or more to 1. When the cellulose is dipped a perforated aluminium or earthenware plate is placed over it in such a way that the acid meniscus is about half way up the perforations and then cold water (at 4°C-8°C) is carefully run onto the plate to form a sealing layer over the acid, so that acid fume no longer escapes and the hood can be removed to another pan. Nitration proceeds for from 1 to 2½ hours, depending on circumstances, and when it is finished the acid is slowly run off from the pan to the spent-acid storage whilst cold water is added above the perforated aluminium plate at a corresponding rate to maintain the upper liquid surface; this operation taking three hours. This is the part of the process which gives it its name (the displacement process), the spent acid being 'displaced' slowly by water in such a way that almost all the acid is recovered undiluted by water while the NC is finally completely covered by water. As the displacement takes place a warm acid-water interface moves down through the NC, effecting some denitration as it goes, so that the process could never be used for the most highly nitrated nitrocelluloses (nitrogen content greater than 13.4%). It is also a less suitable process for the more finely fibrous forms of cellulose, such as liners, in which the interface becomes very diffused as displacement proceeds with consequent risk of higher temperatures leading to 'fume-off'.

76. It is customary to operate the pans in groups of four in a large hall containing many pans in rows. The labour consumption per ton of NC produced is moderately high.



Fig. 12 Displacement nitration

#### *Mechanical process for nitrating cellulose*

77. It has been said (Chapter 2) that smokeless powders came into the British Service largely *via* the American association during the First and Second World Wars. The USA chiefly uses the mechanical process for the manufacture of NC, and for this and other reasons this process has lately been introduced into the Royal Ordnance Factories, primarily for the production of NC of 12.6% N; but obviously it can be used for the manufacture of other NCs, and it will almost certainly have to be used for guncotton if cotton liners should become the only available source of cotton cellulose. It is a convenient process for the nitration of wood-pulp, in the form of small cuttings from sheets, and it may well be that in the future the process may be used in the Service for the production of 'wood NC' of 12.6% N from such pulp and of 'cotton NC' of 13.4% N from a suitable grade of liners, the two products being blended for some purposes.

78. In the mechanical process a battery of four mechanically-stirred nitrating vessels (Fig. 13) is mounted above a bottom-discharge centrifuge into which the contents of the vessels can be dropped in turn as nitration is completed. The charge of acid (containing a higher percentage of nitric acid than for the displacement process) for each vessel is about 50 times the weight of cellulose to be added, and nitration is complete in about 20-25 minutes. Centrifuging off the spent acid takes about 5 minutes, as does the emptying of the centrifuge to a gutter where the NC meets a strong stream of water which conveys it to a washing tank. The time cycle is such that while the first vessel is being charged the fourth is being emptied.

79. The labour usage in this process is fairly low in relation to the output, but some care is required to ensure that no fires occur either in the centrifuge or in the emptying of it.

80. In both the displacement and mechanical processes a large proportion of the spent acid is refortified and returned for re-use. The remainder goes to denitration and reconcentration of the ingredient acids.

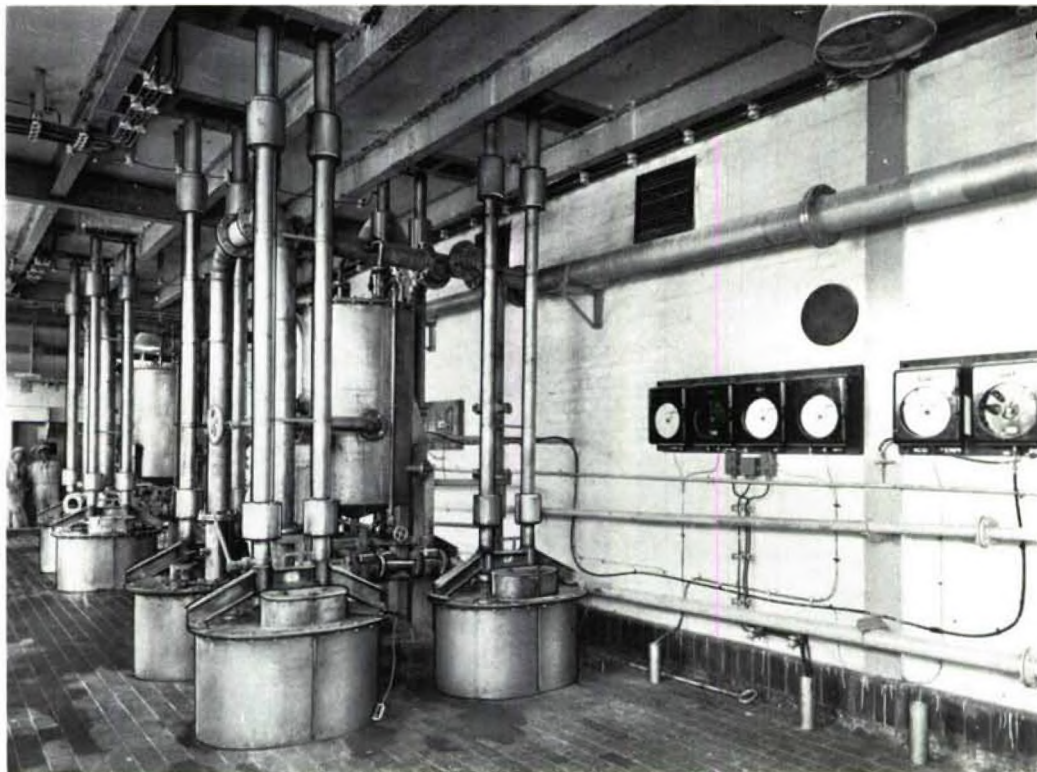

Fig. 13 Mechanical nitration

#### *Stabilization of nitrocellulose*

81. The washed product from either process is now subjected to a stabilization procedure, necessitated by the pronounced tendency of the fibrous NC to retain nitric and, even more, sulphuric acids. This procedure involves prolonged boiling of the NC in water (Fig. 14), followed by a process of chopping in water. It is important that the first stage of boiling shall be under acidic conditions (about 0.05-0.2% calculated as  $H_2SO_4$ ), and this is usually ensured by the acidity present in the washed NC. Thereafter the alkalinity present in a 'hard' water is desirable, and in the British Service it has been preferred to use a number of such boils rather than to shorten the process by the use of added alkali. The length of the first acidic boil depends on the type of nitrocellulose; being 12 hours for displacement NC, 60 hours for mechanical 'pyro' NC (12.6% N), and 96 hours for mechanical guncotton. The subsequent 'hard water' boils for displacement NC's are of 12, 4 and 4 hours duration, while the mechanical NC's are given four boils each lasting 4 hours (or, alternatively, 2 boils each of 8 hours). After the boiling process the NC is fed into cold hard water in a beater (Fig. 15) of the type used in the papermaking industry in which it is sheared between the blades of a rotating roller running just clear of blades set in a bed-plate. This produces a very fine pulp which, after passing through a centrifugal grit separator, may be filtered if the NC is to be dried or may be passed to a dilution tank if the solventless or semi-solventless processes are to be followed. The manufacturing process for nitrocellulose is illustrated diagrammatically in Fig. 16.

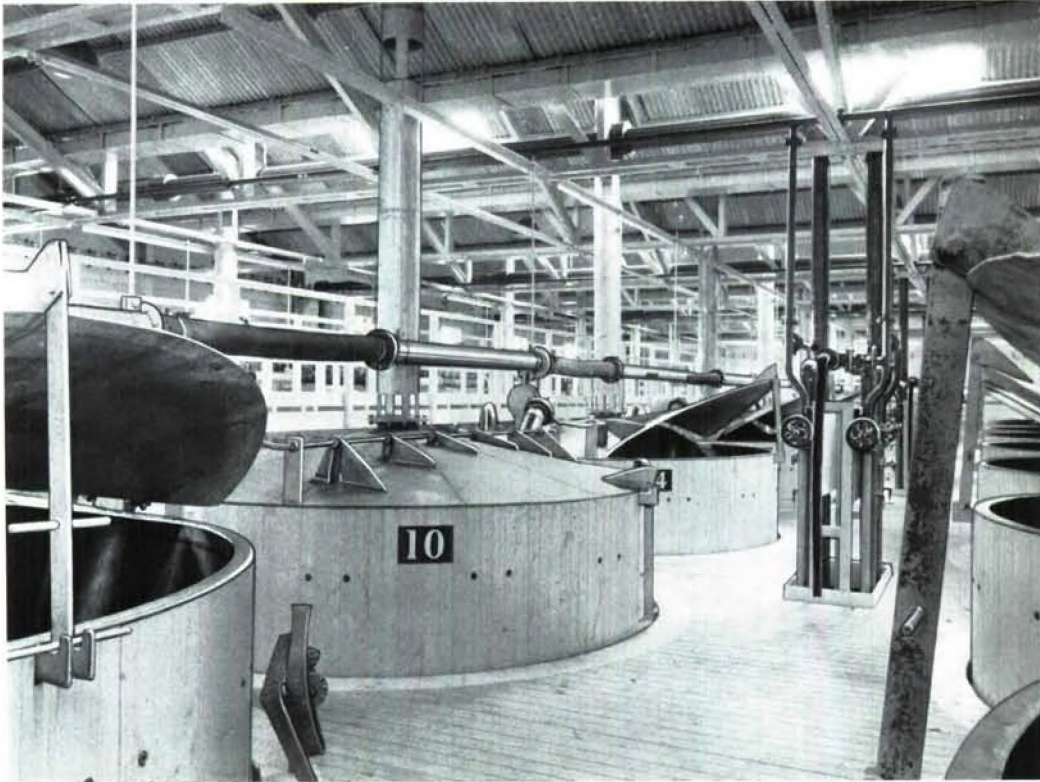

Fig. 14 Boiling nitrated cellulose

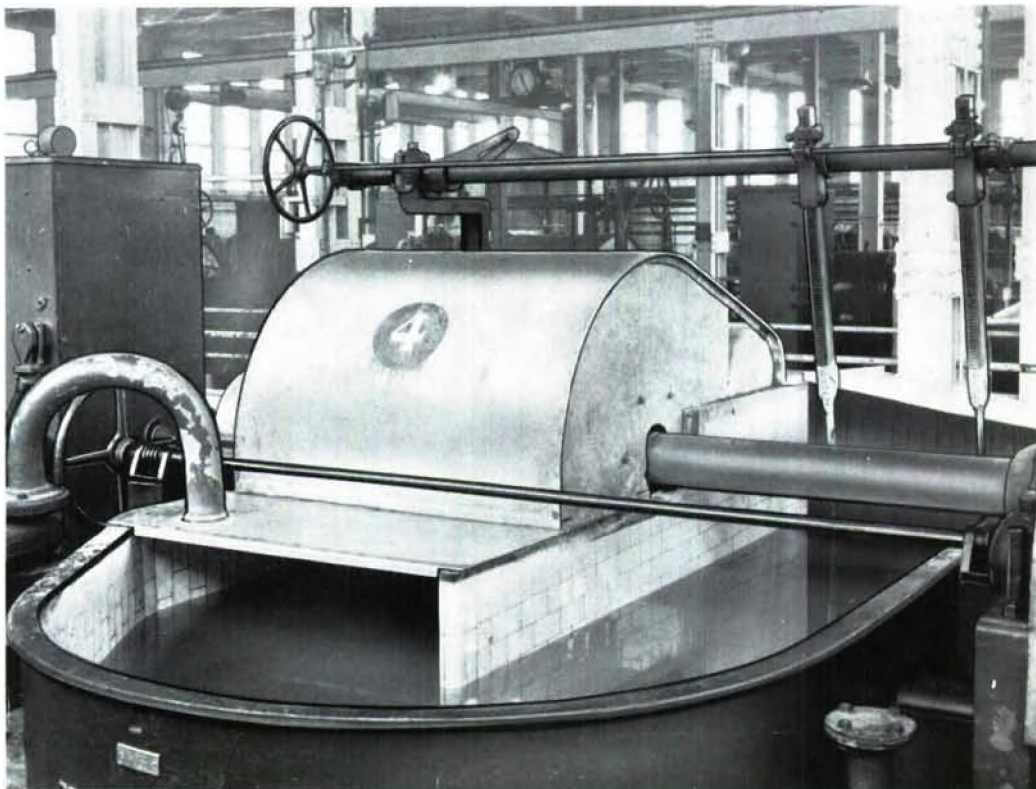

Fig. 15 Nitrocellulose beater

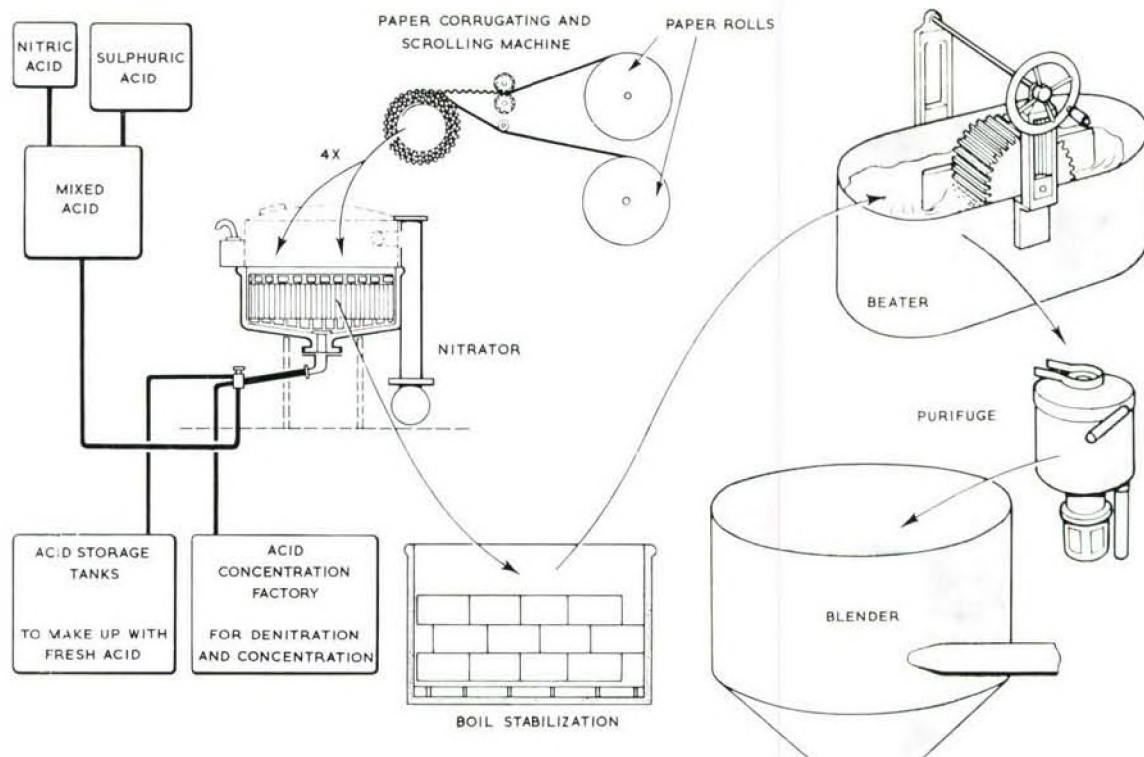

Fig. 16 Nitrocellulose manufacture

#### Properties of Nitrocellulose

82. It has been said that nitrocelluloses are characterized primarily by their nitrogen-content and by their solubility in various types of organic solvent (they are, of course, insoluble in water and for this reason physiologically harmless). They do not dissolve in quite the same way as, say, salt dissolves in water, but the fibres first swell as they 'absorb' solvent and then lose their structure and become gelatinous before becoming a homogeneous solution.

83. When dry, nitrocellulose is a white or creamy-white, fibrous material, very readily ignited and readily becoming charged with static electricity; thus if NC must be dried special precautions are necessary to avoid 'static' risks. Dry NC is very sensitive to friction and to mechanical blows and can readily be detonated. In the wet condition (that is, more than 13% water) NC is insensitive to friction and blows, and compressed slabs of it require a priming charge to bring them to detonation.

#### Glycerine and Nitroglycerine

##### Glycerine

84. Animal and vegetable fats and oils are commonly largely composed of 'glycerides', that is, glycerol esters of aliphatic acids. All glycerol (glycerine) was (and much still is) therefore derived from the alkaline hydrolysis of these natural products, the alkali salts of the fatty acids being the basis of soaps and the glycerol being recovered by distillation in superheated steam. The increasing value of natural fats and oils for food purposes caused the technological development of processes for the synthesis of glycerol which had long been known in the laboratory. Thus, in 1948 the first commercial plant for the synthesis of glycerol from propylene (from petroleum processing) came on stream, utilizing the scheme in Fig. 17.

85. In 1959 a new synthesis became commercial. This depended on the partial oxidation of propylene to acrolein,  $\text{CH}_2=\text{CH}\cdot\text{CHO}$ , by oxygen in presence of a copper catalyst. The acrolein was then mixed with isopropyl alcohol,  $\text{CH}_3\cdot\text{CH}(\text{OH})\cdot\text{CH}_3$ , in the vapour phase at  $400^\circ\text{C}$  when allyl alcohol,  $\text{CH}_2=\text{CH}\cdot\text{CH}_2\text{OH}$ , and acetone,  $\text{CH}_3\text{CO}\cdot\text{CH}_3$ , were formed. The allyl alcohol was then oxidized to glycerol by using hydrogen peroxide (Chapter 5) in aqueous solution in presence of a soluble heavy metal catalyst. An improvement in this process arose from the discovery that propylene oxide,  $\text{CH}_2-\text{CH}\cdot\text{CH}_2$ , readily isomerizes to allyl alcohol when passed on vapour form over triflithium

$\begin{array}{c} \diagdown \text{O} \diagup \\ \text{phosphate} \end{array}$  at  $200-250^\circ\text{C}$ .

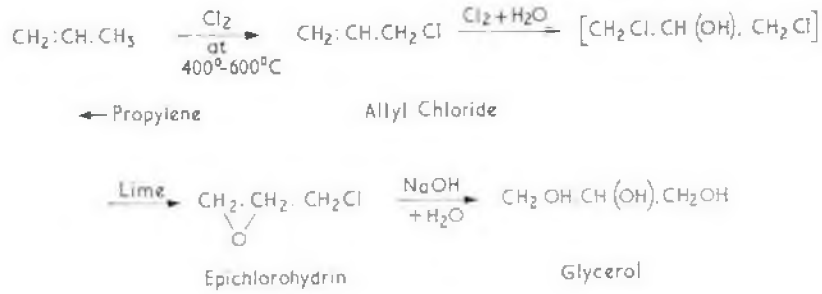

Fig. 17 Synthesis of glycerol from propylene

86. During the long history of glycerine as a product of industrial and medicinal value its purification has received much attention. Pure anhydrous glycerol is a colourless viscous liquid of mp 18.6°C and bp 290°C (with decomposition); its density is 1.261 g/ml. It is hygroscopic and thus it usually contains enough water to depress its melting point.

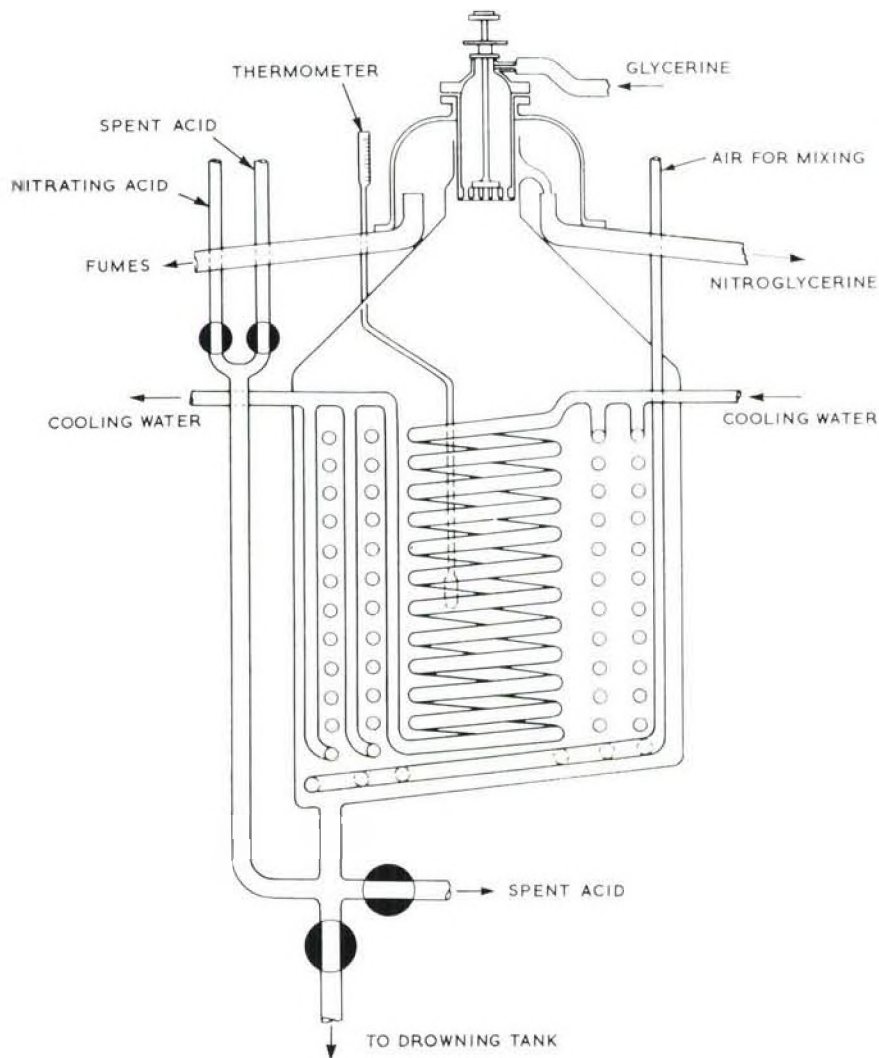

Fig. 18 Nitroglycerine manufacture

*Nitroglycerine (Glycerol Trinitrate)*

**87.** Glycerine can be nitrated using nitric acid alone, but the yield of the trinitrate is low and a fair proportion of dinitrate is also formed. In practice, the best results are obtained by using an anhydrous mixed acid containing 45%–50%  $\text{HNO}_3$  and 50%–55%  $\text{H}_2\text{SO}_4$ , when yields of trinitrate of 91% of theoretical may be obtained, that is, 225 parts of nitroglycerine (NG) may be obtained from 100 parts of glycerine.

**88.** Nitration was for many years conducted by batch processes, many of which were developed. In the British Service the Nathan-Thomson-Rintoul process (Fig. 18), which avoided the use of mechanical stirring gear (air-stirring was used) and of valves, was employed to produce batches of 3600 lb (1633 kg) of NG. However, the risk involved in these processes, even at their best, caused a search to be made for continuous processes in which a much smaller proportion of the total output would be in the plant at any given time. The first commercially successful such process was that of Schmid, introduced into the Ordnance Factories about 1934. It was superseded after the 1939–45 War by the Biazzi process, the plant for which was simpler and more compact. As it is currently in use in the Factories a brief account of it will be given; but it is, in fact, an obsolescent process, due for replacement by the NAB process in which very small quantities of explosive of the order of only a few pounds are present at any time.

**89.** In the Biazzi process (see Figs. 19 to 21) a nitrating vessel of only 250 litres capacity is employed for a rated output of 800–1000 kg/hour. Such a vessel, of stainless-steel with a quintuple bank of cooling coils, can be made as a precision engineering job, so that a high-speed (600 rev/min) turbo-stirrer can be used to emulsify metered flows of glycerine and mixed acid at a temperature of  $10^\circ\text{C}$ – $15^\circ\text{C}$ , the coils being fed with a brine solution at  $-5^\circ\text{C}$ . The emulsion from this nitrator is fed tangentially into a separator, which is of double conical shape, whence the NG leaves continuously at the top to pass to two stirred washing vessels (in series) while the spent-acid is taken from the bottom via an adjustable syphon tube. A hitherto unusual feature of the process is that the first washing vessel is fed with a 12% solution of sodium carbonate (in earlier processes it had been desirable to wash first with water and only then with sodium carbonate); the heat of neutralization is removed by cooling water passing through the jacket of the washing vessel. Biazzi claimed that no further washing of the NG is necessary, but such washing is given in the Ordnance Factories as the NG is transferred as an emulsion in water from the final separator to the next stage in the plant in which it is used. The plant in the Factories is capable of an output of 2500 lb (1134 kg) per hour and uses three washing vessels; it is highly instrumented and is almost automatic in operation by reason of the 'fail safe' devices employed. The control system is outside the process building.

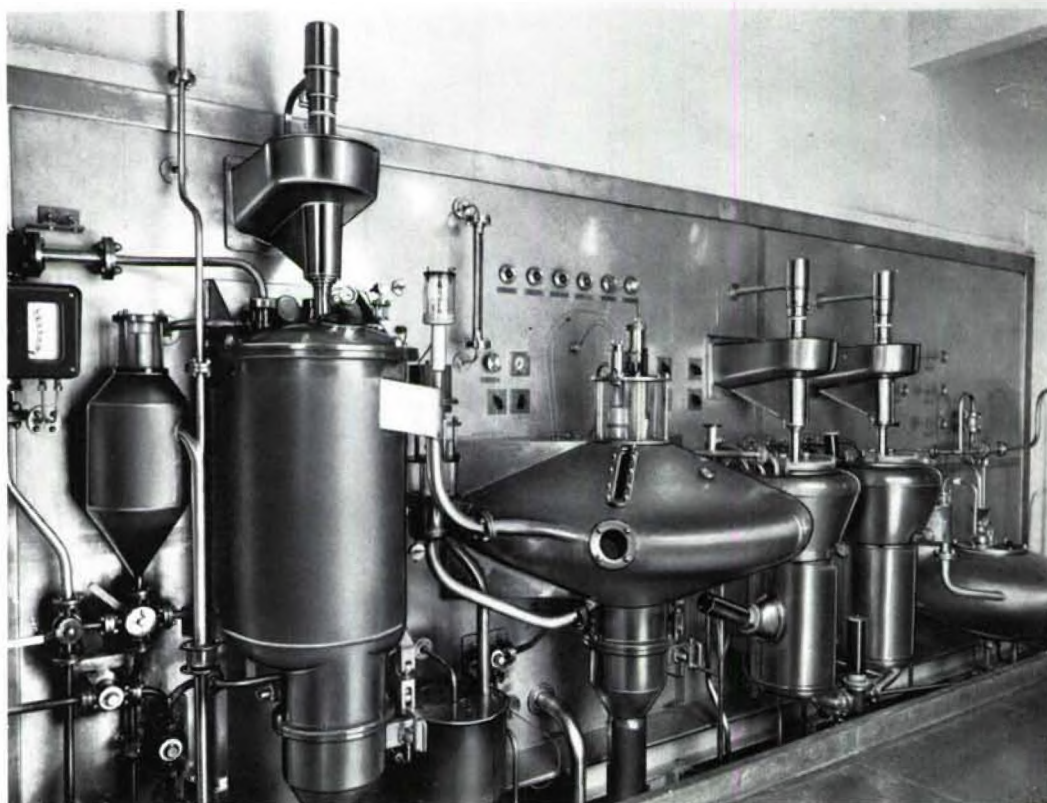

**Fig. 19** Automatic Biazzi plant (Nitroglycerine manufacture)

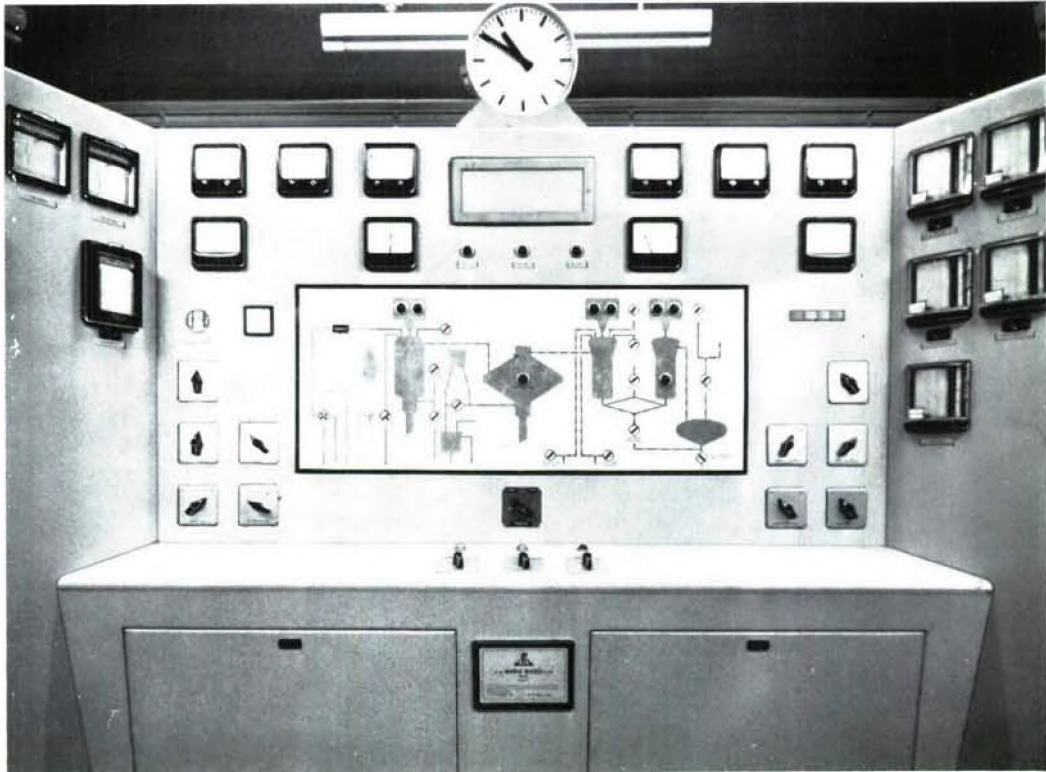

Fig. 20 Control panel for Biazzi plant shown in Fig. 19



Fig. 21 External view of control room for Biazzi plant

90. The NAB or Gyttop process (named after its developers, Nobel Aktien Bolaget, of Gyttop in Sweden, where Nilssen and Brunnberg worked it out in 1950) consists essentially of the nitration of glycerine in an injector fed with mixed acid (see Figs. 22 to 24). This process has the advantage not only of low explosive content in the plant but also of re-using a high proportion of the spent-acid (precooled to act as a heat-transfer medium), something which was not done even in the Biazzi process. To a conventional mixed acid (see para. 87) spent-acid is added in the ratio 1.6-1.75 parts of spent-acid to 1 part of mixed acid, so that the  $\text{HNO}_3$  content of the actual nitrating acid is about 27%, and the water-content is 9.5%-10%. The nitrating acid is cooled to  $0^\circ\text{C}$  and pumped at a gauge pressure of about  $345 \text{ kN/m}^2$  ( $50 \text{ lb/in}^2$ ) into the jet of the stainless-steel injector, thus creating in the body of the injector a vacuum (*cf* the laboratory water-jet vacuum pump) which draws in a feed of glycerine (at  $45^\circ\text{C}$ - $50^\circ\text{C}$ ); automatic pressure controls ensure that the ratio of glycerine to acid is correct, but the principle ensures a high degree of safety, for a fall in the acid flow inevitably results in a still greater reduction in the glycerine flow. An unusual feature of the process is that the nitration temperature in the injector is  $45^\circ\text{C}$ - $50^\circ\text{C}$ ; but as this is maintained for so short a time before the mixture passes to a coil cooler where its temperature is reduced to  $18^\circ\text{C}$ , the quality of the nitroglycerine after washing has been shown to be acceptable for service. From the cooler the mixture of nitroglycerine and refuse acid is led to a continuous centrifugal separator operating at 3200 rev/min. For a nitration unit capable of operating at 2500 litres of mixture per hour the quantity of NG in the separator bowl is only 3.5 kg, so that although the use of this high-speed machine gives an apparent risk it is one which can be readily isolated in a small earth-covered concrete cell; in fact, such machines have run very well. NG can be seen leaving the separator within 2 minutes after the nitration process has begun. Having reduced the quantity of NG in the plant up to this point so notably, it is now important to ensure that the washing process does not introduce accumulations of explosive and that large quantities are not finally built up in storage vessels. In the United Kingdom the washing process has been reduced to a series of injector-fed emulsions with sodium carbonate solutions and water, the last of which can lead the NG to the next process in which it is used.

91. However NG is made, it is undesirable that the spent-acid should be stored for long after it has been separated from the NG, since slow decomposition of dissolved NG occurs with liberation of heat, which may lead to explosion of any NG which has separated (say, as the temperature falls at night) and is floating on the surface of the bulk of acid.

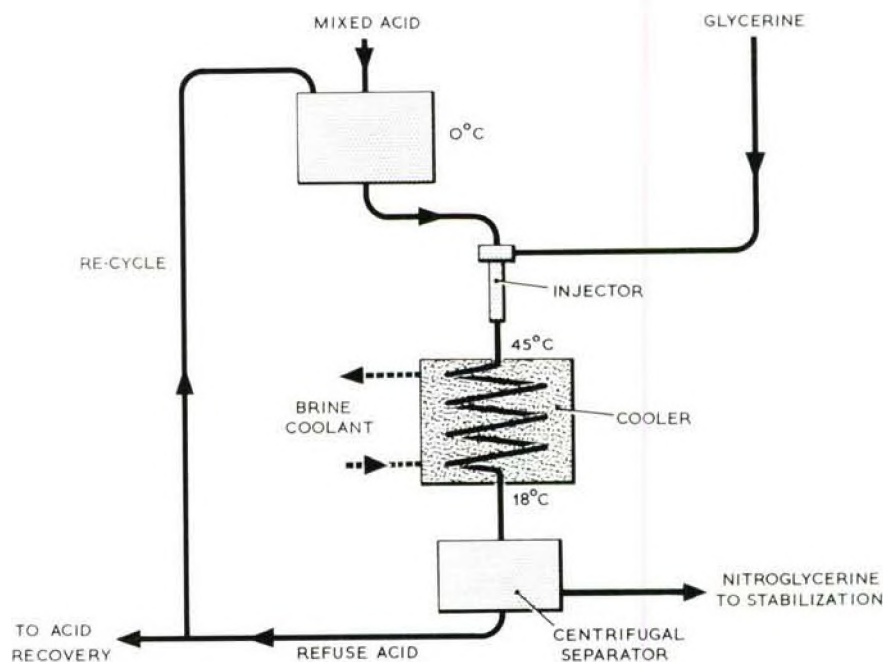

Fig. 22 The NAB process for the manufacture of nitroglycerine



Fig. 23 Two injectors for dual stream nitration of glycerine



Fig. 24 Centrifuge for separating nitroglycerine from refuse acid

*Properties of Nitroglycerine*

92. Pure nitroglycerine is a colourless transparent oily liquid; but as manufactured it may have a faintly yellow tint. NG exists in the solid state in two forms, one labile (fp = 2°C) and one stable (fp = 13°C). It is said that very pure NG does not crystallize until about 2°C when the labile form appears, and that this does not very readily transform into the stable forms. What is common experience is that NG can often be cooled well below 13°C before any sign of crystallization occurs, and that if the NG which has crystallized is remelted it readily crystallizes again in the form in which it previously existed, unless in the interim it has been warmed for some time to above 50°C. Thus, 'supercooling' and 'crystal seeding' are phenomena characteristic of the solidification of NG and liable to be important if cooled NG is to be handled, as the stable solid form is somewhat more sensitive to impact shock than is the labile form; though, as neither is as sensitive as the liquid, this may account for the observation that a partially frozen NG is more sensitive than either liquid or solid, since presumably a film of liquid may be subject to friction between the surfaces of crystals.

The density of NG is about 1.595 g/ml at 20°C.

93. The vapour pressure of NG at moderate temperatures is appreciable, though there has been some difficulty in securing agreement as to the precise values, those of (A) Brandner (1938) and (B) Kemp, Goldhagen and Zihlman (1957) being probably the best as given in Table I below.

Table I

## Vapour pressure of nitroglycerine

°C	(A)	(B)
	mm Hg	mm Hg
20	—	0.0002
30	0.0012	0.0011
35	0.0020	—
40	0.0030	0.0035
45	0.0047	—
50	0.0081	—

94. Table I shows that NG is sufficiently volatile for this volatility to be an important factor to be taken into account from the safety standpoint in the construction of buildings and plant in which it is handled and in the design of munitions in which compositions (usually propellants) containing it are present, since such munitions may experience various extremes of temperature during storage.

95. As an explosive substance, nitroglycerine is oxygen-rich, or 'over-balanced', that is, when all the carbon has been burned to CO<sub>2</sub> and all the hydrogen to H<sub>2</sub>O there is residual unused oxygen.

96. The chemical stability of well-washed NG is adequate in the absence of acidity, strong alkalies and reducing agents.

97. From the physiological standpoint, NG is a powerful vasodilator. Most workers become accustomed to it, but some must be removed from contact with it.

98. In this country the transport of NG in public places is prohibited, but HM Chief Inspector of Explosives may permit the transport by road of solutions of NG in suitable diluents, for example, glycerol triacetate ('triacetin').

**Glycols and glycol nitrates***Glycol*

99. Brief reference must be made to the glycols if only because glycol dinitrate is sometimes employed as an additive to NG and used in some commercial blasting explosives to reduce the freezing point of the NG.

**100.** Glycol,  $\text{CH}_2\text{OH}\cdot\text{CH}_2\text{OH}$ , is the product of the alkaline hydrolysis of ethylene oxide,  $\text{CH}_2\text{CH}_2$ ,  
 $\searrow \quad \swarrow$   
 $\text{O}$   
 which is readily available in the petrochemical industry. A certain amount of higher glycols (or, more exactly, polyglycol ethers) is produced at the same time and is separated by fractional distillation: the most important of these for present purposes is diethylene glycol (DEG),  $\text{CH}_2\text{OH}\cdot\text{CH}_2\text{O}\cdot\text{CH}_2\cdot\text{CH}_2\text{OH}$ .

Both glycol and DEG are clear colourless liquids, the former boiling at  $198^\circ\text{C}$  and the latter at  $245^\circ\text{C}$ .

#### Glycol nitrates

**101.** Both glycol and DEG can be nitrated by using mixed acids similar to those used to make NG and, in fact, the former is often nitrated in admixture with glycerine for commercial explosives. The spent-acid from the nitration of glycol is rather more stable than that obtained in NG nitrations, but that from the nitration of DEG is rather unstable and is best fed rapidly to denitration, even though its composition can be adjusted to improve its stability.

**102.** Glycol dinitrate, DGN or EGDN, freezes at  $-22.5^\circ\text{C}$  and boils at  $197.5^\circ\text{C}$ . (Note: However, if it must be distilled this should be done at a lower temperature, using reduced pressure and suitable precautions!) Its density is  $1.489 \text{ g/ml}$  at  $20^\circ\text{C}$ .

**103.** Diethylene glycol dinitrate, DEGDN exists in two solid forms, the stable one freezing at  $-2^\circ\text{C}$  and the labile one at  $-11^\circ\text{C}$ . The liquid boils at  $160^\circ\text{C}$  (with decomposition!) and has a density of  $1.385 \text{ g/ml}$  at  $20^\circ\text{C}$ . It has frequently been considered as an ingredient of double-base propellants, wholly or partly replacing NG, and was so used by the Germans in the 1939-45 War; it gelatinizes NC very well and has good chemical stability. However, its vapour pressure is appreciably higher than that of NG.

#### Other Aliphatic nitrates

**104.** Most aliphatic alcohols can be nitrated, using mixed acids similar to that used for the nitration of glycerine; the nitrates separate readily from the spent acid. However, the only one which has been of Service interest is iso-propyl alcohol, the nitrate of which,  $\text{CH}_3\text{CH}(\text{O}\cdot\text{NO}_2)\cdot\text{CH}_3$ , is usually referred to as IPN; it was, in fact, made industrially by a continuous method involving the progressive addition to boiling 70% nitric acid (containing urea) of iso-propyl alcohol and fresh acid, the IPN distilling off continuously to be washed and dried. The yield in the manufacture was not good, but the raw materials were cheap and the process simple. IPN is a clear to white liquid boiling at  $101^\circ\text{C}$ . It was used in certain engine starters, in which it was decomposed to give hot gases when sprayed onto a catalyst bed containing chromium oxides; these gases were then employed to drive a turbine. Because IPN is not an explosive within the meaning of the Explosives Acts there might be a tendency to treat it as a mere 'fuel', and it may be as well to draw attention to the fact that its low boiling point corresponds with a high vapour pressure at ordinary temperatures, with the consequence that it readily forms explosive mixtures with air; it is unwise to employ compressed air to expel IPN from vessels.

#### Aliphatic nitrocompounds (nitroparaffins)

**105.** From time to time suggestions have been made for the use of nitroparaffins (nitromethane, nitroethane and the 1- and 2-nitropropanes) as energetic fuels for possible military systems, but nothing has come of them. All are produced in the United States petrochemical industry by the continuous vapour-phase nitration of paraffins at more or less high temperatures, and nitromethane can be made by the distillation of sodium chloroacetate with sodium nitrite.

**106.** The presence of an  $-\text{NO}_2$  group attached to a carbon atom in a compound renders hydrogen atoms attached to that atom reactive, and thus nitromethane,  $\text{CH}_3\text{NO}_2$ , and nitroethane,  $\text{CH}_3\text{CH}_2\text{NO}_2$ , react with formaldehyde under alkaline conditions to yield 'nitro-isobutylglycerine' and methyl-nitropropanediol, respectively (Fig. 25a and b).

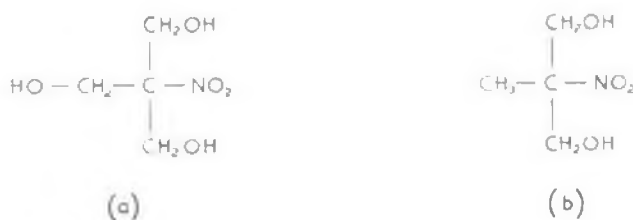

Fig. 25 Nitro isobutylglycerine (a) and methyl-nitropropanediol (b)

These polyhydric alcohols can be nitrated, and some consideration has been given to the use of the nitrates as ingredients of propellants.



properties of the final gun cordite, and a product of specific surface 200-300 dm<sup>2</sup>/ml is obtained by 'flashing' a saturated aqueous solution made at 120°C under pressure; as this solution enters a chamber at atmospheric pressure it cools rapidly to about 40°C.

*Coolant plasticizers*

**112.** It is sometimes required to produce a cordite-type composition of lower than usual energy. This can be done by 'dilution' of either the nitrocellulose (for example, with cellulose acetate) or the nitroglycerine, but the latter method is preferred on stability grounds. If part of the NG is to be replaced the substitute should have at least equivalent plasticizing powers for the nitrocellulose; obviously, it must be chemically and physically compatible with all other ingredients. Accordingly it is preferred to use as coolant-plasticizers esters of a volatility not greater than that of nitroglycerine. The esters preferred in the British Service are ethyl and butyl phthalates (Fig. 28a and b) and 'triacetin' (glycerol triacetate) (Fig. 28c).

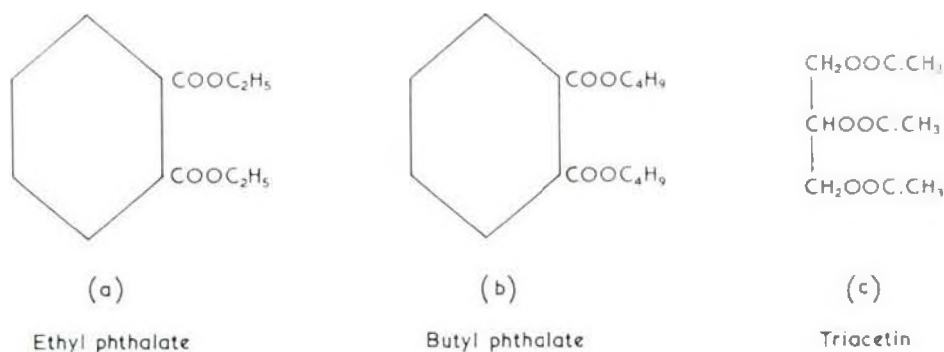
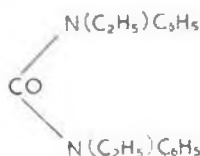

**Fig. 28** Some coolant-plasticizer esters

These are made industrially and are clear colourless liquids or low melting point solids of high boiling point.

*Stabilizers*

**113.** All propellants made from nitrocellulose, with or without nitroglycerine, require the presence of stabilizers to remove the traces of nitrous oxides which form during the life of the propellant. The early British cordites employed for this purpose a mineral jelly, a 'Vaseline' containing unsaturated paraffins which reacted with the nitrous oxides. Such a stabilizer would be inconvenient as a constituent of nitrocellulose powders for which, at an early date, diphenylamine, (C<sub>6</sub>H<sub>5</sub>)<sub>2</sub>NH, was preferred as a suitably basic substance. However diphenylamine is too basic for use in presence of nitroglycerine, and when 'solventless' cordites were being developed in the British Service a search was made for another stabilizer, when it was found that diphenyl-diethyl-urea (Fig. 29) is not only a good stabilizer but has



**Fig. 29** Carbamite

useful plasticizing properties. The substance was given the Service name 'carbamite'; it is known outside the United Kingdom as 'ethyl-centralite', in contradistinction to 'methyl-centralite' which is much used in applications other than stabilizing.

**114.** Both diphenylamine and carbamite are made in industry for Service use, the former by heating aniline, C<sub>6</sub>H<sub>5</sub>NH<sub>2</sub>, with its hydrochloride at 210°C-240°C, and the latter by the reaction of ethyl-aniline, C<sub>6</sub>H<sub>5</sub>(C<sub>2</sub>H<sub>5</sub>)NH<sub>2</sub>, with phosgene, COCl<sub>2</sub>.

**115.** Diphenylamine is a white crystalline material of mp 53°C, readily soluble in alcohol and ether. Carbamite forms white crystals melting at 72.5°C.

*Moderants*

**116.** For ballistic reasons it is convenient to retard the initial stages of the burning of some nitro-cellulose powders and this is done by coating them with a thin layer of a compatible organic substance such as methyl- or ethyl-centralite, dibutyl phthalate, dinitrotoluene, *etc.* Compounds so used are called 'moderants'. If they have low-melting points they are applied by rumbering them with the powder in a warm drum; otherwise a small quantity of solvent is used to bring them into contact with the powder.

**117.** Graphite may also be used as a moderant (see Chapter 2) when it has the additional useful effects of rendering the powder more free-flowing and less susceptible to the accumulation of electrostatic charges.

**Polyisobutylene**  $[C(CH_3)_2.CH_2]_n$ 

**118.** Isobutylene,  $(CH_3)_2C=CH_2$ , is separated from other C<sub>4</sub> hydrocarbons in the petro-chemical industry by absorption in sulphuric acid of 45%-65% concentration, in which it dissolves preferentially to form isobutyl alcohol. The acid is subsequently diluted to 45% and distilled with super-heated steam when pure isobutylene is recovered. The latter is polymerized at low temperature in presence of a cationic initiator, usually boron trifluoride or aluminium chloride.

**119.** The polymer (whatever its molecular weight, which may correspond to that of a viscous liquid or a rubber) is a chemically very stable hydrocarbon.

**Surface-active agents**

**120.** If inorganic salts such as ammonium perchlorate or ammonium nitrate are to be incorporated with organic fuels, for example, hydrocarbon or other rubbers, it is not easy to bring the salt into intimate contact with the organic phase. This problem is overcome by the addition to the system of small quantities of 'surface-active' agents, which are frequently salts or esters of sulphonic or carboxylic acids of high molecular weight. It is generally considered that the polar end-groups (salt or ester) attach themselves to the surfaces of the crystals of the oxidant and that the organic part of the agent molecule is then free to form some kind of molecular association with the organic phase.

**121.** Various substances of this type are made in industry, mainly for use in the detergent field, and are used alone or in mixtures in certain composite propellants.

**Dimethylhydrazine**

**122.** Although this substance has not yet found use in the British Service so much has been said about it in literature on rocket propulsion that a short note on it is appended here. Its use in certain liquid propellant rocket motors in the United States arose from the inconveniently high melting point (*ca* 2°C) of hydrazine, which was depressed by adding dimethylhydrazine (usually to the extent of a 50% admixture).

**123.** The dimethylhydrazine employed is the 'unsymmetrical' one,  $(CH_3)_2N.NH_2$ , readily made from (commercially available) dimethylamine by the route given in equation 6.



It is a toxic liquid, boiling at 81°C.

## CHAPTER 7

## Explosives and explosive compositions and their uses

## CONTENTS

	<i>Para</i>
<b>Gunpowder, slowmatch, quickmatch and fuze compositions</b>	1
<i>Gunpowder</i>	1
<i>Slowmatch</i>	12
<i>Quickmatch</i>	13
<i>Fuze compositions</i>	14
<b>Detonating cords and Line-cutting charges; Giant Viper</b>	18
<b>Picric acid; 'Shellite'; Ammonium picrate; 'Picric powder'</b>	22
<i>Picric acid</i>	22
<i>Shellite</i>	23
<i>Ammonium picrate</i>	24
<i>'Picric powder'</i>	25
<b>Tetryl ('CE')</b>	26
<b>TNT and TNT compositions</b>	31
<i>TNT</i>	31
<i>Amatols</i>	34
<i>Baratols</i>	36
<i>TNT/WAX</i>	37
<b>RDX and RDX compositions</b>	38
<i>RDX</i>	38
<i>RDX/TNT</i>	39
<i>EDCI composition (RDX/TNT/HMX)</i>	41
<i>RDX/WAX</i>	42
<i>Plastic explosive</i>	43
<i>Rubber-bonded RDX compositions</i>	45
<b>PETN and Pentolite</b>	46
<i>PETN</i>	46
<i>Pentolite</i>	48
<b>HMX and HMX compositions</b>	49
<b>Aluminized compositions</b>	50
<i>Ammonal</i>	52
<i>Minols, Tritonal</i>	53
<i>Torpex</i>	54
<i>Aluminium/perchlorate compositions</i>	55
<i>RDX/Wax/Aluminium</i>	56
<b>Miscellaneous solid and liquid compositions</b>	57
<i>Wet guncotton</i>	57
<i>Nobel's 851</i>	58
<i>Nobel's 852</i>	59
<i>Ammonal (commercial variants)</i>	60
<i>Nitroglycerine-based blasting explosives</i>	61
<i>Dithekite</i>	66
<i>ANFO</i>	67
<i>'FAX' (fuel/air explosive)</i>	68

## CHAPTER 7

**Explosives and explosive compositions and their uses****Gunpowder, slowmatch, quickmatch and fuze compositions***Gunpowder*

1. The early history of gunpowder has been outlined in Chapter 2 and it is only necessary now briefly to take up its use in the British Service in later years.
2. In 1865, ten different types of gunpowder were in use and the use of each depended on the requirements of the various rifles and cannon then in Service.
3. Before the introduction of rifled ordnance, charges for guns were made of large-grain black powder. The shell used in a rifled gun, however, was some three times the weight of that in a smooth-bore gun of the same calibre, thus to avoid the development of excessive pressures in the gun a slower-burning powder was needed, and in 1860 RLF powder was introduced to meet this requirement; it had a higher density and was of larger grain size than earlier powders. It was used in the Armstrong gun, for which the charge was a quarter of the weight of the shell.
4. As the size of rifled guns increased, still slower-burning powders were required, and the simplest way of obtaining these was to continue to increase the grain size. Eventually a pelleted powder was adopted in 1866, and in 1869 'pebble ('P') powder' (in cubes) was approved for all gun charges larger than 40 lb (18 kg), and later a larger grain ('P2') was employed for 12-inch guns.
5. A still further improvement was the introduction of moulded, or 'prism', powder. 'Prism 1', introduced in 1881, was in regular hexagonal prisms 1 inch high and 1.4 inch in length of side.
6. In 1884, brown powders (also known as 'cocoa' powders) were introduced for breech-loading guns. They used a less strongly carbonized ('brown') charcoal, and were very successful as slow-burning powders but were less easily ignited than the earlier powders, consequently a small primer of black powder was required with the charge.
7. A still slower powder, 'EXE', was introduced in 1887; it employed two grades of charcoal. It was the last development in the artillery field before the general introduction of cordite.
8. At the present time, gunpowder continues to have a wide range of Service uses primarily in pyrotechnic stores (Chapter 10). A brief description of its manufacture follows.
9. Charcoal, sulphur and saltpetre (Chapter 5) are ground and sieved to the required sizes and are then mixed, in the proportions appropriate to the desired gunpowder, by milling in a large edge-runner mill in presence of a controlled small quantity of distilled water. This water not only contributes to safety but has an influence on the burning time of the finished powder, presumably because its presence affects the particle-size distribution. Milling requires 3 to 6 hours, depending on the type of powder, after which, if a sample is to requirement, the charge is removed from the mill (using wooden implements to avoid undue friction) and is passed through a coarse (6 meshes per inch) screen and pressed at a controlled load and for a specific time. The pressed cake is then broken up by pressing it through a series of spiked rollers and the product sieved to eliminate coarse and fine sizes, which are reworked. The mid-size granules may be glazed by rumbling with graphite (although graphite glazing is not generally used in United Kingdom gunpowder), and dried at 40°C to a moisture content of about 1% (which is somewhat below the equilibrium value in average atmospheric conditions in this country).
10. Gunpowder is chemically stable, but is adversely affected by water; traces of moisture (depending on the amount) impair ignition and larger quantities leach out the soluble potassium nitrate. It burns to produce CO<sub>2</sub>, CO, N<sub>2</sub> and a residue ('slag') of K<sub>2</sub>CO<sub>3</sub>, K<sub>2</sub>SO<sub>4</sub> and potassium sulphide in proportions depending on its composition and on the conditions under which it is burnt. A sulphurless gunpowder ('SFG') is made for use in proximity to materials with which sulphur is incompatible; 'brown' charcoal is employed in its manufacture.
11. Although gunpowder has the advantages of being readily ignitable and of being insensitive to percussion and rough handling when filled into stores, as well as of being made from cheap and non-reactive ingredients, it has the disadvantage of a high and variable moisture content (which cannot easily be removed by drying) and of being difficult to make with a reproducible burning rate. These disadvantages are attributable to the properties of charcoal, and therefore a good deal of work has been done to find a substitute for charcoal. Some success was achieved with nitro-indene polymer and with

tetranitrocarbazole; the former was found useful in a delay composition, but the latter, when mixed with potassium nitrate, proved less ignitable than gunpowder though otherwise comparable with it as a pyrotechnic composition.

#### Slowmatch

12. Slowmatch consists of a slightly twisted hemp which has been boiled in a dilute aqueous solution of potassium nitrate. It burns at a rate of 1 yard (0.91m) in 8 hours.

#### Quickmatch

13. Quickmatch is a cotton wick impregnated and coated with a paste of sulphurless gunpowder and dusted with fine sulphurless gunpowder when nearly dry. Exposed, it burns at a rate of 1 yard (0.91m) in 30 seconds, but much more rapidly when enclosed.

#### Fuze compositions

14. *Time-fuze compositions*: Several gunpowder-type compositions are used, of which SR 227 is typical. It consists of:

Potassium nitrate	72 parts by weight
Charcoal	21 " " "
Sulphur	7 " " "

However, gunpowders leave a 'slag' residue (para. 10) and this is undesirable in some applications.

15. RD 202, which is slagless and can give long times of burning, has the composition:

Ammonium perchlorate	24.2 parts by weight
Charcoal	23.0 " " "
Starch	2.2 " " "

It is sensitive, and its manufacture calls for careful precautions.

16. Some fuzes require a 'gasless' delay powder, and several compositions have been evolved. An early one was:

Barium chromate	70.9 parts by weight
Manganese powder	27.1 " " "
Sulphur	2.0 " " "

which was bonded with 2 to 3 parts ethyl cellulose and was used in a blend with an equal proportion of an igniting composition consisting of:

Red lead	85 parts by weight
Silicon	15 " " "
Ethyl cellulose	2 to 3 " " "

17. *'Instantaneous' fuzes*: Apart from the 'matches' (para. 12 and 13) there are two forms of cord-type fuze:

- (1) *Safety (Bickford) fuze* in which a gunpowder core is enclosed in a braided flax or jute tube covered with rubber. This burns at 2 feet (0.61m) per minute.
- (2) *Instantaneous fuze* in which two or more strands of quickmatch are enclosed in a loose fabric sheathing. It burns at 90 feet (27.4m) per second.

#### Detonating cords and Line-cutting charges; Giant Viper

18. *Detonating Cords* are sometimes known in Service as FID ('fuze instantaneous detonating') or 'cordeau', the original type (now obsolete) consisting of a  $\frac{1}{4}$ -inch (6.3mm) bore lead or lead-tin alloy tube filled with pure TNT; it detonated at 5000 metres per second, but if used in long lengths it had to be boosted every 100 yards (91m) by a guncotton primer. It was not very flexible. Later types are the British 'cordtex' and the equivalent American 'primacord'. These consist of PETN in waterproof wrappings. They detonate at 6000 to 7000 metres per second.

19. *Line Cutting Charge (LCC)* is a flexible linear 'shaped charge' which makes use of the Munroe jet effect to give a sharply defined cutting action. It consists of an explosive core (RDX, HMX, PETN or one of the high-temperature-resistant explosives) in a metal tube (lead, antimonial lead, aluminium alloy, etc.) having a chevron-shaped cross-section so that, when the open end of the V is laid against a surface, detonation produces a plane jet which will cut the surface. LCC may be bent to small radii without impeding detonation.

20. *Miniature Detonating Cord (MDC)* consists of an explosive composition, RHA (95% RDX plus 5% HMX), in a lead sheath. It has hitherto been used only as a cutting agent, being very flexible and capable of small radius bends without impairment of detonation. Because it does not employ the

Munroe effect its (smaller) cutting action is not so dependent on the accuracy of its placing as is that of LCC. It is used to open the canopies of aircraft to facilitate emergency ejection of crew. LCC is employed to open up the skins of weapon-dispensing devices or to sever the straps to release parachutes from heavy stores.

21. *Giant Viper* is an extension of the concept of the line charge and may be used to clear a track through minefields. It consists of 750 feet (229m) of hemp or nylon hose containing a charge of 300 lb (136 kg) of an aluminized plastic explosive (para. 43). The charge is introduced into the hose in the form of wrapped cartridges (density 1.6 to 1.62 g/ml) which are consolidated by compressed air. The hose is launched over the minefield by a rocket system.

#### **Picric acid; 'Shellite'; Ammonium picrate; 'Picric powder'**

##### *Picric acid*

22. Picric acid (Chapter 6) is now unlikely to be met with in the British Service, although it was used as a pressed filling for shell from about 1890 until the 1914-18 War. Also known in the Service as Lyddite (after the site in Kent where early experimental work was done on shell filled with picric acid), it was considered very suitable for armour-piercing shell as it would withstand the shock on impact or penetration before being subsequently exploded by the fuze system.

##### *'Shellite'*

23. 'Shellite' was usually a mixture of 70 parts picric acid and 30 parts 2:4-dinitrophenol, having a melting point of 83°C, and thus it could be filled as a melt. It was also regarded as a good filling for AP shell and bombs. It has been obsolete as a filling since 1955.

##### *Ammonium picrate*

24. Ammonium picrate has recently had only one use in the British Service, as an ingredient of some plastic propellant compositions. But, under the name Explosive D, it still finds some use in the United States Service as a relatively insensitive shell filling. The use of ammonium picrate calls for the same lead-free conditions as were specified for picric acid, that is, no material with which it comes in contact should contain more than 0.03% lead.

##### *'Picric powder'*

25. 'Picric powder' was at one time in use in the British Service as a composition for use in exploders fitted with an igniferous fuze, from which it would ignite and develop a high rate of explosion. It was a mixture of 43% ammonium picrate and 57% potassium nitrate. It may still be encountered in unexploded German bombs from the Second World War.

#### **Tetryl (CE — composition exploding)**

26. Although not at first much used as an explosive filling (partly because of its high melting point and partly because it was not available in the quantity required in the First World War) tetryl was soon in use as an exploder, or booster, for TNT-filled shell, for which purpose it was pressed into pellets which were placed in cavities left in the cast TNT: it was itself capable of being detonated by the initiating system of the shell. This use of tetryl for exploder systems for shell and bombs continues.

27. In the 1939-45 War, however, CE was used as a pressed filling for some 20 mm and 30 mm shell, the automatic hydraulic press having been developed in the meantime to render this a feasible production operation.

28. Tetryl is used in many composite Service detonators (Chapter 9 and 13) being pressed into the aluminium sheath first, with the initiating composition above; such detonators may be regarded as small initiator-booster systems.

29. Tetryl cannot be used in contact with picric acid, which impairs its stability; nor should it be used in proximity to gunpowder, since mixtures of the two are very sensitive.

30. Mixtures of CE/TNT have been used in the Service in the proportion of 70/30 as a demolition explosive (cast slabs) and 30/70 as a grenade filling (cast), but such mixtures are rather prone to exudation.

#### **TNT and TNT compositions**

##### *TNT*

31. Because of its melting point of just over 80°C, TNT is usually filled into Service stores, either alone or in compositions, by pouring from steam-jacketed vessels. Care must be taken to prevent

cavitation as the charge cools, but techniques have been developed to ensure a charge density of 1.58 g/ml for pure TNT. The cavities required for the subsequent insertion of exploder systems are formed by the use of hollow plastics formers during the casting of the charge.

32. Small shells and trench-mortar bombs having charges of 1 oz to 4 oz (28g to 113g) are filled on continuous plant, and continuous processes may also be used for filling larger items provided that arrangements are made for the filling to be done in increments. TNT compositions are frequently made up or adjusted in the Filling Factories.

33. Pure TNT is remarkably stable, and the chief problem presented in the use of TNT is to ensure a degree of purity which will avoid 'exudation' of TNT isomers which (apart from constituting a fire risk and explosive hazard, and possibly causing prematures) may penetrate into exploder systems and safety and arming units and prevent their correct functioning. If the exudate penetrates to a tetryl exploder it will form with the tetryl a liquid eutectic of enhanced sensitivity. Accordingly, it is nowadays customary in the British Service to have only two grades of TNT with setting points respectively of 80.4°C and 80.2°C.

*Amatols*

34. Mixtures of TNT with ammonium nitrate, generally known as 'amatols', were developed in the First World War to eke out supplies of TNT and to take advantage of the 'oxygen-rich' character of the nitrate to compensate in some measure for the deficit of oxygen in TNT (Amatol 80/20 is a 'balanced' explosive). The proportions are usually indicated by the fractional percentages, for example, Amatol 60/40 contains 60% ammonium nitrate. They are sensitive to moisture because of their ammonium nitrate content, and should not be allowed to come into contact with copper or its alloys since ammonium nitrate may form sensitive copper compounds. Amatols containing 40% or more of TNT can be poured, but 50/50 Amatol is the 'thickest' that is convenient for pouring into shell. 80/20 Amatol is employed for cast-iron mortar bombs, and 70/30 and 60/40 Amatols can conveniently be used for fillings of bombs and mines, the lower is the TNT content the less the shrinkage on cooling. Although 50/50 and 40/60 Amatols have been used in shell they are not efficient in modern steel shell.

35. During the development of large light-cased bombs in the Second World War it was found difficult to ensure the complete detonation of Amatol. Accordingly, small proportions of RDX were added to sensitize the filling, and the resulting composition was known as Amatex. Amatex 9, developed for the 8000 lb (3.62 Mg) bomb, was 55/36/9 AN/TNT/RDX. The Amatexes were superseded by aluminized compositions.

It may be of interest to note the following velocities of detonation (VOD):

Explosive	Density	VOD
TNT	1.58 g/ml	6950 m/s
Amatol 40/60	1.5	6470
Amatol 80/20	1.45	5080

Because of its dustiness and hygroscopicity ammonium nitrate is rather a nuisance to the Filling Factories.

*Baratols*

36. The Baratols are mixtures of TNT with barium nitrate which avoid some of the disadvantages of the Amatols; barium nitrate is non-hygroscopic. But they have found only limited use (20/80 or 30/70 Baratols have been used in grenades and anti-tank mines) and are not generally suitable for shells, bombs or mines.

*TNT/WAX*

37. Mixtures of TNT with a small proportion of beeswax have been used for armour-piercing (AP) shell.

**RDX and RDX compositions**

*RDX*

38. Because of its sensitiveness, RDX is not supplied to the Filling Factories as such. In the RDX manufacturing plant it is wet-mixed with either TNT or wax or oils and is then pelleted (by cooling the suspension in hot water whilst stirring rapidly) and dried; RDX/TNT is dried in the molten form and cast as slabs.

*RDX/TNT*

39. The RDX/TNT composition most usually made is 60/40 (or, more exactly, 59.5/39.5 plus 1% of wax; beeswax, paraffin wax and synthetic microcrystalline waxes have been used in the important role of 'densensitizer') which can be diluted with more TNT in the Filling Factories if required. RDX/TNT

is now a preferred poured filling for modern steel shell, 'shaped charge' weapons, fragmentation warheads and continuous-rod warheads because of its superior explosive properties and higher density in comparison with TNT as well as its small tendency to cavitation on cooling. In the British Service the fillings are usually 'topped' with a little TNT, but this is not done in the United States.

40. 'RDX/TNT 1B' is a 60/40 RDX/TNT to which has been added 0.25% of  $\frac{1}{4}$ -inch Terylene fibres, to reinforce the explosive against shock stresses.

#### *EDC 1 Compositions (RDX/TNT/HMX)*

41. Composition EDC 1 contains HMX as well as RDX, TNT and 1% beeswax and has been developed for special fillings. It is one of a range of EDC compositions which have higher density and V of D than the RDX/TNT compositions.

#### *RDX/WAX*

42. RDX/WAX is usually made with 9% to 12% wax which may be a high-melting paraffin wax or a synthetic 'micro' wax. On heating in steam-heated incorporators it becomes sufficiently plastic to be used as a pressed filling for certain shells designed to achieve penetration of armour. It is also used for booster pellets in fuze magazines.

#### *Plastic explosive*

43. Plastic explosive (PE) is a mixture of RDX with about 12% of plasticizer consisting usually of oil or grease. Plastic explosives are used for demolition and a typical example (PE 4) consists of RDX plasticized with a lithium-based grease. It is formed into charges, for example paper-wrapped cartridges which can be detonated by a detonator containing a small base charge of tetryl.

44. In tropical climates the simpler forms of PE showed a tendency to soften and 'slump'. This was overcome by incorporating up to 10% carbon black into the composition.

#### *Rubber-bonded RDX compositions*

45. Arising out of work on aluminized explosives for underwater use (para. 50) there have recently been developments in the direction of rubber-bonded RDX compositions for certain special uses. The rubber usually employed is a castor-oil-based polyurethane which renders the resulting RDX composition insensitive to some forms of mechanical shock (for example, massive charges of 'Poly-X' can be safely bounced onto concrete); but some sensitivity measurements are less reassuring.

### **PETN and Pentolite**

#### *PETN*

46. Like RDX, PETN is too sensitive to use 'neat' in most stores and is usually mixed with some wax or with an equal proportion of TNT.

47. In admixture with a paraffinic wax, known as 'Montan' wax, PETN was much used by the Germans for exploder pellets. The desensitized (or 'phlegmatized') explosive was made in the manner described above for RDX, but it was usual to add a small quantity of a dyestuff to characterize the product.

#### *Pentolite*

48. Pentolite is best made by mixing equal parts of PETN and TNT in hot water suspension, as for RDX/TNT. However, this 50/50 mixture was found rather too sensitive for small, high-velocity shell, and it is desensitized by addition of a mixture of paraffin wax, nitrocellulose and lecithin (a surface-active agent prepared from soya bean or ground nut), so that the final composition, known as PEN/D 1, is:

PETN	46	parts by weight		
TNT	46	"	"	"
Wax	6.9	"	"	"
NC	1.0	"	"	"
Lecithin	0.1	"	"	"

Care is needed to ensure the complete dispersion of the components of the desensitizing mixture through the mass of molten pentolite. PEN/D 1 has a 'power' of 113 (TNT has a power of 95). Pentolite has been used for some smaller shell (up to 40 mm) but, on the whole, RDX/TNT is preferred.

### **HMX and HMX compositions**

49. It will be obvious that considerations of 'cost-effectiveness' must enter into the choice of an explosive composition for use in a military store, and it is evident from Chapter 6 that HMX is an

expensive explosive. Accordingly, it will be apparent that HMX compositions — the explosive is never used 'neat' for reasons of safety — are used only in 'special' systems where the advantages to be gained from the somewhat higher density and velocity of detonation of HMX as compared with RDX justify the higher cost. Such compositions range from phlegmatized HMX to mixtures of HMX with TNT, sometimes containing also RDX (for example EDCI composition, para. 41), and may contain small proportions of fibrous materials to give improved mechanical properties.

### Aluminized compositions

50. It is often required in the field of high-capacity light-cased explosive stores (for example, aircraft bombs and underwater weapons such as mines and torpedoes) to increase the blast effect as compared with the fragmentation effect, that is, to produce a long, flat, pressure-time curve rather than a 'peaked' curve. (A discussion of the mechanism of air blast explosions will be found in Textbook of Air Armament, AP 110A-0300-1A4 and underwater explosions in AP 110A-0300-1A6.) It was found that this result could be achieved, without marked effect on fragmentation, by the inclusion in the explosive composition of finely-divided aluminium. Study of the detonation of such compositions has shown that the aluminium does not enter into the first stage of reaction but that it adds heat to the overall system by its subsequent reaction with some of the gaseous products of the first stage.

51. Among the reactions which may take place are:



Since the last of these reactions is undesirable because it reduces the volume of gases, it will be apparent (apart from the obvious fact that increasing the proportion of aluminium must lead to a point of 'diminishing returns' in terms of heat per unit weight of composition) that there is an optimum value to the aluminium content of the composition, and this is found in practice to lie between 10% and 20% for different explosives. The blast effectiveness of aluminized compositions is enhanced by light confinement: this is probably because the extra energy required to disrupt a heavy container reduces the temperature to a degree which inhibits the complete oxidation of the aluminium. In underwater weapons, conditions are modified by the fact that water is a better working fluid than is air, and American work indicates that the maximum underwater shock-wave energy is given by a Torpex-type explosive (see para. 53) containing 25% aluminium, and the maximum bubble energy by one containing 40% aluminium.

#### *Ammonal*

52. The first aluminized composition to be used in the British Service was Ammonal, a mixture of ammonium nitrate/TNT/aluminium power/charcoal in the proportions 65/15/17/3 (para. 60); it was employed in the First World War as a demolition explosive and then for bombs and grenades.

#### *Minols, Tritonal*

53. Between the wars there was some controversy as to the relative merits of heavy fragmentation-type aircraft bombs and the light-cased blast-type bombs, but when this was resolved early in the Second World War in favour of the latter for generalized bombing (as opposed to the attack of 'hard' targets such as fortifications, etc.), aluminized compositions were required in considerable quantity. Meanwhile the need for such compositions for underwater stores (for example, mines and depth charges) was well appreciated and the Minols were introduced. Minol 1 was ammonium nitrate/TNT/Al in the ratio 42/48/10 and Minol 2 was 40/40/20. Such compositions were, however, prone to evolve gases due to the reaction of the aluminium with water present in association with the ammonium nitrate (AN), and care had to be taken to mix the AN and TNT thoroughly and to dry the mixture before the aluminium was added. (Because of these disadvantages the Minols have not been considered suitable fillings in peacetime.) To avoid this problem a TNT/Al, 80/20 composition that had had limited uses before the Second World War was resuscitated (it is now known in America as Tritonal). This was followed (especially for torpedo warheads and, later, bombs) by Torpex, a mixture of RDX/TNT/Al.

#### *Torpex*

54. A range of Torpex compositions evolved, some of which are used in shell. Torpex 2 had the composition RDX/TNT/Al in the ratio 40/42/18 and was preferred for torpedo warheads (see also Chapter 13). For shell filling it was found desirable to desensitize the Torpex by the addition of a little paraffin wax, and this became the practice for many other stores (which might be subject to rough handling in the field, anyhow); the desensitizing agents had as a subsidiary advantage the improvement of the physical properties of the explosive at low temperatures and of minimizing any tendency to the formation of explosives dust. Another problem which arose with the Torpexes was that, pourable as they were, there was a risk of segregation of aluminium (density 2.7 g/ml; density of organic phase about 1.7

g/ml); this was overcome by addition of some carbon black. In the Torpexes, as in the Minols, care must be taken to exclude moisture, otherwise gases (mainly hydrogen) are produced in the filled munition store and may be a source of subsequent danger.

#### *Aluminium perchlorate compositions*

55. In recent years, the extensive use of aluminium in association with ammonium perchlorate in rocket propellant compositions (Chapter 8) has caused interest in the possibilities of related systems for use as underwater explosives. Having regard to the problem of the avoidance of segregation of aluminium in the Torpexes, the underwater explosives technologist views the propellant-like systems as 'plastics-bonded explosives' (PBX), in which the large proportions of aluminium and perchlorate are 'potted' in a double-base or fuel matrix. One type of PBX under development has about 27% of aluminium and 39% of ammonium perchlorate bonded with a nitrocellulose/explosive plasticizer composition. Another takes advantage of the low melting point of lithium perchlorate trihydrate (ca 80°C) to use this material as a bonding agent; however, the composition is not easily detonated unless, say, RDX is added, and this can be done only in small proportions if undue sensitiveness is to be avoided; moreover, the water of crystallization of the lithium salt results in some reaction with the aluminium, with production of hydrogen, and this would seem to render this system unacceptable for Service use, although it is of scientific interest in the study of underwater explosion phenomena. In this country interest has been centred in the use of castor-oil-based polyurethane rubber, plasticized with nitroglycerine, as a bonding agent for the aluminium and ammonium perchlorate.

#### *RDX/Wax/Aluminium*

56. Finally, a pourable aluminized RDX/wax composition (RDX/Paraffin Wax/Al in the proportion 68/12/20) has been developed for armour-piercing shell; a little lecithin is present to ensure 'wetting' of the RDX and Al by the wax.

#### **Miscellaneous solid and liquid compositions**

##### *Wet guncotton*

57. Wet guncotton is a demolition explosive but is obsolescent, if not obsolete, in the Service. It was made in the form of a hydraulically-pressed slab weighing 1 lb and of dimensions 6 in x 3 in x 1.47 in, having a tapered hole for the insertion of a primer pellet (either dry guncotton or tetryl). The slab, which had a water content of about 15%, was packed in a hermetically-sealed 'tin' case. The slabs could be cut with a tenon saw provided that water was played on the cut. Because of its rigidity, which causes difficulty in bringing the slab into good contact with some objects which it may be desired to attack, the wet guncotton slab system was displaced by plastic explosive, 'PE' (para. 43).

##### *Nobel's 851*

58. Nobel's 851 is a plastic explosive consisting of Pentolite (50/50) (para. 48) mixed with nitrocellulose and dibutylphthalate. It was used during the 1939-45 War as a substitute for PE, but it tends to harden on storage and is less effective than PE.

##### *Nobel's 852*

59. Nobel's 852 also was a wartime substitute for PE. It consists of PETN bonded with nitrocellulose plasticized with an oily mixture of nitrotoluenes. It has almost as good demolition properties as PE and was less inclined to 'slump' in hot climates than the first PE compositions (PE3 and 3A have been developed for such climates).

#### *Ammonal (commercial variants)*

60. There are several commercial variants of ammonal, which is essentially aluminized 80/20 amatol. They consist of:

Ammonium nitrate	65-70 parts by weight
TNT	15-20 .. ..
Aluminium powder	10-17 .. ..
Charcoal or other additive	1-3 .. ..

Ammonals are very effective 'mining' explosives of low velocity of detonation (3000 to 4000 metres/sec). They are grey powders which can be stemmed to a high density of loading but they are hygroscopic and must be stored carefully.

#### *Nitroglycerine-based blasting explosives*

61. *Dynamite*. Now long obsolete, this was originally a mixture of nitroglycerine (up to 75%) with kieselguhr, a diatomaceous form of silica. It could not be used in wet conditions as water displaces NG from it. A development of dynamite involved the replacement of kieselguhr with (combustible) wood meal, to which was next added sodium or potassium nitrate. The next stage of development was the use of a mixture of soluble NC ('collodion cotton'), wood meal and potassium nitrate as the absorbent for NG; this product was known as Gelatine Dynamite.

**62. Blasting Gelatine.** This is a mixture of NG and just enough soluble NC to give a 'balanced' composition, that is, one in which the products of combustion contain neither oxygen nor free carbon but in which all carbon exists preferably as CO<sub>2</sub> and all hydrogen as water. It therefore contains 91.5% NG, 8.0% collodion cotton, 0.2% chalk and 0.3% water (associated with the NG), and this is one of the most violent explosives in use. It is a gelatinous solid not readily affected by water.

**63. Gelignite.** This is a generic name for a range of compositions consisting of NG, soluble NC, wood meal and sodium nitrate (cf Gelatine Dynamite, para. 61). Gelignite 50 contains 50% NG. 'Polar' versions of Blasting Gelatine and Gelignite may be met with in which part of the NG has been replaced by dinitroglycol or other nitrate to reduce the risk of freezing in cold climatic conditions.

**64. Nobel's 808.** This was used in Service in the 1939-45 War. It is a desensitized polar blasting gelatine of somewhat plastic nature, but rather rubbery. It tended to exude NG in hot climates.

**65. Nobel's 822.** This is a liquid mixture of 80/20 nitroglycerine nitroglycol, desensitized with 12% of dibutyl phthalate and stabilized with 1% of carbamate. It found some use in the 1939-45 War.

Note . . .

None of the nitroglycerine-based explosives should be exposed to temperatures above 120°F on ground of impairment of stability.

#### *Dithekite*

**66.** Intimate mixtures of liquid oxidants and liquid fuels in appropriate proportions are, of course, explosives; they are described generically as 'Sprengel' explosives, after the inventor of the first mixture of a liquid fuel with an oxidant (nitrobenzene with sodium chlorate). From time to time rumours of such liquid systems of extraordinary power would arise in the 'preatomic era' — although in fact, the most powerful chemical system would not have a power greater than 210 (picric acid power is 100; NG power is 192). Such a rumour arose in the Spanish civil war, and consideration of it led to the decision in the Research Department, Woolwich, to re-examine mixtures of nitrobenzene and nitric acid as a cheap liquid explosive which might substitute for amatol in suitable circumstances. The mixture was named 'dithekite', and was made directly by bringing together benzene and 93% nitric acid in a continuous reactor consisting of a stirred vessel fitted with water-fed cooling coils; the use of acid of such concentration ensured that dinitrobenzene would not be formed with consequent increase in sensitivity of the mixture. The explosive was available for use in the 1939-45 War, but was not required as supplies of TNT, etc, were always adequate.

#### *ANFO*

**67.** There is a vast range of patent literature on explosive compositions, many of which are undesirable for military use on grounds either of unsuitability for exposure to a wide range of climatic conditions or of sensitivity to shock such as rifle bullet or fragment attack. The 'Cheddites', which are mixtures of nitrocompounds with potassium chlorate, fall in the latter category; they are blasting explosives. But a recent development in the sphere of rock blasting may become of Service interest. In the last decade there has been a steady increase in the use of a mixture of ammonium nitrate and fuel oil (lately known as ANFO) for such blasting; its popularity has grown on economic grounds (the ingredients are cheap and readily accessible) and it has had a pronounced effect on the market for commercial blasting explosives. Since ammonium nitrate decomposes under extreme conditions to yield an atom of free oxygen per molecule:



and since fuel oil is a mixture of hydrocarbons of general form C<sub>n</sub>H<sub>2n+2</sub> and C<sub>n</sub>H<sub>m</sub> it can be seen that 3 molecules of ammonium nitrate are required for the complete oxidation of a >CH<sub>2</sub> group. As the molecular weight of ammonium nitrate is 80 and of the >CH<sub>2</sub> group is 14, it is apparent that a mixture of about 94.5% AN and 5.5% FO is balanced. The patent literature in recent years contains many claims for the advantages of using a little more or a little less than 5.5% oil and for using ammonium nitrate in various particle sizes and having various surface pre-treatments, principally directed to rendering it more or less water-resistant. In general it is best to employ a granular AN, so that the mixture is not too 'dry', whilst the value of a pre-coated AN is most apparent where the mix is made by first filling the bore-hole with AN and then adding oil, since the hole may be wet. Although the early use of the system involved this *in situ* mixing, there has been a growing tendency to pre-mixing, either on site or remotely; but it has not always been remembered that the mixture is an explosive and must not be exposed to fire risks, with the consequence that one or two disasters have occurred. To fire the mixture in the bore-hole a small priming charge (usually of a gelignite) is required.

#### *'FAX' (fuel/air explosive)*

**68.** It is desirable to make some reference to the fuel/air system, allusion to which might be met with elsewhere. When it is considered that the combustion of 1 gramme of carbon will yield 9.1 kcal and that of 1 gramme of a hydrocarbon will yield about 11 kcal, whilst the heat of explosion of 1 gramme of

TNT is only 0.66 kcal, it will be apparent that if mixtures of fuel and air could be made at will and ignited efficiently their destructive power should be of considerable military interest; manifestations of that destructive power occur from time to time in coal mines, in flour mills and by way of town-gas explosions in buildings. Both in this country and in Germany the potentialities of coal dust for the destruction of buildings (for example, bunkers and fortifications) were studied during the 1939-45 War, while the Germans also used gas/air explosions and found carbon monoxide and ethylene to be good fuels. In the British work it was found that a bursting charge of gunpowder, weighing about a sixth of the weight of the coal dust, gave good results both in dispersing and igniting the fuel; but, because the rate of rise of pressure is low (for all dust-type fuels), venting in the early stages of the explosion (say, by partial collapse of the structure) results in little further damage being done. After the Second World War interest in the subject lapsed but has lately been revived, and development work is proceeding with systems in which a suitable liquid fuel is dispersed in the open atmosphere by a central burster charge which does not ignite the cloud of fuel which, however, is detonated by a subsidiary explosive charge to give typical blast-type damage effects on surrounding targets. A study of the detonation wave so produced shows numerous reflections from the ground, thus it may be expected that a system of the type described might be useful for the attack of trenches, bunkers and minefields in addition to being lethal to troops and capable of clearing jungle and damaging light structures on the ground (for example, radar installations and parked aircraft).

## CHAPTER 8

## Propellants

## CONTENTS

	<i>Para</i>
<b>Introduction</b>	1
<b>Single-base propellants</b>	5
<b>General</b> .....	5
<i>Early history</i> .....	5
<i>Non-hygroscopic and flashless powders</i> .....	7
<i>Solvent release</i> .....	8
<i>Manufacture of single-base powders</i> .....	9
<b>The Ball-Powder process</b> .....	11
<b>NRN (Nobel's Rifle Neonites) powders</b> .....	15
<b>Double-base propellants</b>	
<b>General</b> .....	19
<i>Cordite (manufacturing development)</i> .....	19
<i>Muzzle flash</i> .....	23
<i>Smoke</i> .....	29
<b>Solvent cordites</b> .....	31
<i>Drying guncotton</i> .....	31
<i>Manufacture of NC/NG paste</i> .....	32
<i>Semi-solvent process</i> .....	38
<i>Picrite-carbamite complex</i> .....	39
<i>Ballistite</i> .....	40
<b>Solventless cordites</b> .....	41
<i>Manufacture</i> .....	41
<i>Advantages of solventless method of manufacture</i> .....	45
<b>Cast-double-base propellants</b> .....	47
<i>Manufacturing considerations</i> .....	47
<i>Advantages of the casting process</i> .....	49
<i>Description of CDB process</i> .....	51
<b>Composite propellants</b>	
<b>Choice of materials</b> .....	58
<b>Plastic propellant</b> .....	63
<i>Manufacture of plastic propellant</i> .....	67
<i>Representative plastic propellant compositions</i> .....	69
<i>Limitations of plastic propellants</i> .....	70
<b>Rubbery composite propellants</b> .....	71
<i>Some advantages and disadvantages</i> .....	71
<i>General principles</i> .....	73
<i>Manufacture of rubbery composite propellants</i> .....	78
<i>Miscellaneous rubbery composite propellants</i> .....	81

**Composite modified cast-double-base propellants, CMCDDB**

**Liquid propellants**

<b>General and historic</b> .....	86
<b>High test peroxide</b> .....	89
<b>Isopropyl nitrate, IPN</b> .....	91

**Hybrid propellants**

**Illustrations**

<i>Fig</i>		<i>Page</i>
1	Dewatering of GC/NG slurry .....	10
2	Cutting extruded propellant strands .....	10
3	Heating carpet rolls (by dielectric means) .....	12
4	Extrusion of propellant from hydraulic press .....	13
5	Examples of various solventless cordite extrusions .....	13
6	Casting equipment .....	16
7	Casting assembly for rocket motor .....	17
8	Casting assembly for large rocket motor about to be filled with powder .....	17

**Tables**

<i>No</i>		
1	Some British cordites .....	7
2	Representative propellant compositions .....	20

## CHAPTER 8

### Propellants

#### Introduction

1. Whereas it is the purpose of 'high' explosives, burning rapidly throughout their mass, to produce hot expanding gases at a very high rate consistent with the concepts of 'explosion' or 'detonation', it is the function of propellants, burning in layer-to-layer fashion on their surfaces, to produce expanding gases at (usually) lower temperatures (because the operating pressures are lower) and at lower — and controlled — rates so that they may do work in some kind of mechanical system rather than in a violent, destructive manner. The mechanical system may be some form of gun, rocket, engine starter, seat ejector or other piston device.
2. It was soon realized during the development of gunpowder in the 15th century that, although its composition might remain constant, its rate of combustion could depend on its physical form and the conditions under which combustion took place. Thus, finely divided gunpowder (known as 'serpentine') burnt very rapidly and was generally unsuitable for use in cannon; in which, however, a measure of ballistic control could be obtained if the gunpowder was first prepared in granular form or, better, in prism form. A further measure of control could be obtained if the surface of the granules or prisms was free from powder dust and was 'glazed' with graphite. Again, if the gunpowder, whatever its form, was under confinement (whether in an iron case or a heavy barrel or even in the 'self-confinement' of a heap of powder) it would burn with explosive violence, but if it was in a gun (so that its confinement decreased as the shot moved forward) it would burn more or less controllably. From the standpoint of solid propellants it has remained true that, besides chemical composition, the degree of sub-division, the geometrical shape and the nature of the surface are the important elements in securing controlled ignition and burning.
3. In the British Service the solid propellants have remained more important than the liquid propellants. Although in the years immediately following the 1939-45 War a good deal of attention was given to both mono- and bi- propellant liquid systems, it came to be recognized that the mechanical adjuncts to their employment (pumps, pressurizing systems, tanks, pipework, *etc*) were inconvenient for weapons which must always be ready for use (for example, anti-aircraft missiles) or must be subjected to field conditions. Accordingly remarks on liquid propellants will be deferred until later in this Chapter.
4. Composite and colloidal propellants are the two main groups into which all solid propellants may be divided. A composite propellant is one which has chemically separate ingredients which can be designated either fuel or oxidant components. Composite propellants may be considered to be either plastic propellants, propellants consisting of a mixture of compounds consolidated under high pressure, or propellants distinguished by having a polymerizable binder. A colloidal propellant is a homogeneous dispersion of a polymer (usually nitrocellulose) with a mixture of gelatinizers and plasticizers (predominantly nitric esters) to give a colloidal gel structure.

#### Single-base propellants

##### General

##### *Early history*

5. It was remarked in Chapter 2 that Schultze and Vieille, in 1865 and 1890 respectively, produced propellant powders based on nitrocellulose. Because he had gelatinized the nitrocellulose, thus destroying its fibrous structure, Vieille's powders had the more regular ballistic properties. For reasons described in Chapter 2, single-base powders (that is, those based on nitrocellulose alone) were not employed in the British Service until the events of the First World War caused their introduction from America, when powders were produced characterized as NCT, NCY and NCZ to indicate their physical form or composition. NCT for instance was in the form of short cylinders perforated with seven holes; NCY was a composition containing barium and potassium nitrates, and used for a 3-inch mortar charge. Except for NCY, which was a composition containing fibrous NC, the single-base propellant powders were made by gelatinizing 'soluble' nitrocellulose (12.6% nitrogen content) with an ether-alcohol mixture in incorporators and adding to the dough 0.5% of diphenylamine. The dough was then extruded through dies of appropriate size and shape from hydraulic presses, and chopped and dried.

## RESTRICTED

6. Although large quantities of propellant powders (especially of NCT) were used in the Land Service in the First World War, they were considered too hygroscopic for permanent adoption. They also had the disadvantages that:

- (1) the drying process did not remove every trace of solvent which tended to diffuse out slowly so that on storage the ballistic properties of the powders underwent slow change (and in some instances even became embrittled) resulting in irregular ballistics and sometimes high gun pressures
- (2) they give considerable 'muzzle flash' which, especially at night, disclosed the position of the gun to the enemy.

### *Non-hygroscopic and flashless powders*

7. In the years between the First and Second World War, the single-base propellant powders (para. 5 and 6) were modified to eliminate or at least reduce their disadvantages. The first step was the production of the NH ('non-hygroscopic') powders which contained 86% NC (13.1% N, a blend of 12.6% and 13.4% N), 10% dinitrotoluene (DNT), 3% dibutyl phthalate (DBP) and 1% diphenylamine (DPA). These were markedly less hygroscopic and had a lower flame temperature, but were still not flashless. Accordingly, they were succeeded by the FNH (flashless non-hygroscopic) powders which had been rendered still 'cooler' by replacing 2% of NC with that additional amount of DBP. However, the flashlessness of FNH powder was only slightly better than that of NH powders, and the next step was to add to the composition 1% to 2% of potassium sulphate, a known flash suppressor for combustible gases; the powders of this composition were known as FNH/P. For the larger guns even FNH/P was not adequate, and a supplementary quantity of potassium sulphate had to be loaded into the gun along with the propellant charge; alternatively in some guns a larger than otherwise necessary gunpowder igniter was employed, contributing potassium ions being derived from the extra potassium nitrate. Large quantities of NH, FNH and FNH/P powders were used in Land and Naval Service guns in the 1939-45 War, and as these powders were produced in short lengths (grains) they were, in fact, very advantageous for the filling of the cartridge cases of the ammunition for certain quick-firing guns where the 'neck' of the case was too narrow to permit of filling with a bundled charge of cordite of appropriate weight.

### *Solvent release*

8. It will have been noticed that, while improvements had been made to reduce hygroscopicity and flash, nothing has been said about the retention and subsequent slow release of solvent. In fact this problem is inherent in the nature of this type of single-base powder; when the solvent-wet grain from the cutting process is dried the surface becomes horny (as does the whole grain as drying proceeds) so that the later stages of solvent removal are slow, even at stoving temperatures. Thus, to ensure adequate regularity of ballistics it is necessary to see that these powders, whether in 110 lb cans in bulk or filled into cartridge cases, are kept in a well-sealed condition.

### *Manufacture of single-base powders*

9. The manufacture of single-base powders is carried out as follows:

- (1) the wet suspension of NC from the stabilizing and beating processes (see Chapter 6) is passed to a filtering centrifuge where the NC is retained at about 25% moisture-content
- (2) moist NC is packed into the specially designed cylinder of a hydraulic press and, when it has been compressed, alcohol is pumped through it to displace the water. This is known as 'alcohol dehydration'
- (3) the block of alcohol-wet NC is broken up in a set of spiked rolls (the 'block-breaker')
- (4) the NC is then incorporated with ether (about 2 parts to 1 part of alcohol remaining in the NC). In the United Kingdom this is done in incorporators provided with cooling jackets and of a type similar to those normally used for cordite, but in the USA an additional stage involving a machine known as a macerator is employed to produce an improved gelatinized dough. DNT, DBP and DPA are added with (or dissolved in) the ether. The total solvent employed is about equal to the weight of the NC
- (5) the dough, varying in colour from yellow to brown, is block-pressed at about 3000 lb/in<sup>2</sup> (20.68 MN/m<sup>2</sup>) and then pressed (through strainer gauzes) into cords of about ¼-inch diameter
- (6) the cords of dough are put into press cylinders and extruded through dies to give either a 'solid cord' or a '7-hole cord' of the desired diameter. The pressure required is 2000 lb/in<sup>2</sup> (13.79 MN/m<sup>2</sup>) to 4500 lb/in<sup>2</sup> (31.03 MN/m<sup>2</sup>) (solvent cordite is extruded at 1500 lb/in<sup>2</sup>, 10.34 MN/m<sup>2</sup>, to 4500 lb/in<sup>2</sup>, 31.03 MN/m<sup>2</sup>).
- (7) the cords are cut to grain length on a multiple-feed 'bacon slicer' in which the rotor (having up to 48 blades) is driven by an oil-hydraulic motor
- (8) the grains are partially dried in a current of warm air with solvent recovery (only 35% of the total usage being recovered). They are then steeped for several days in warm water to assist the removal of residual solvent and again dried in warm air; this procedure appreciably shortens the overall drying time and can be used to afford control of the burning rate of the powder

(9) the dried powder is blended in lots of up to 100 000 lb (45.36 Mg). In the USA this is done in a set of towers with conveyors from the bottom of one tower to the top of another; but great care is needed to avoid electrostatic risks.

10. If the grains are individually examined a small proportion may be found to have defects of shape, but if the powder lot has been well blended the defects do not impair the achievement of satisfactory and regular ballistics at proof.

#### The Ball-Powder process

11. In recent years a new process, the Ball-Powder process, has been developed for the manufacture of single-base powders for small-arms; it can also be applied to the production of small-arms powders in which the composition includes a proportion of nitroglycerine.

In essence the process consists of the following operations:

(1) the partial gelatinization of gun cotton, 13.1% N, (although other nitrocelluloses may be employed) using a water-immiscible solvent

(2) the addition of the 'lacquer' so formed to water in a stirred pan to break it up into globules, and raising the temperature of the water to distil off the solvent, whereupon the globules of lacquer harden to spheres of nitrocellulose.

12. In practice, in order to obtain spheres chiefly in a desired size-range, within the range 0.01 inch (0.25 mm) to 0.04 inch (1.02 mm) dia, close control must be exercised over the design and operating speed of the stirrer system. To obtain well-shaped spheres, gun arabic must be added to the water; and, to obtain spheres free from occluded water, sodium sulphate must be added to the suspension in the pan. By the exercise of close control over the concentration of the lacquer, the size and timing of the additions to the process and the rate of heating and distillation of solvent, well-formed spheres of good size-range can be obtained.

13. Early work on the concepts behind this process began in America in 1893, but the process was only brought to the commercial stage by the Western Cartridge Company in 1933. During the 1939-45 War that firm employed it to produce large quantities of propellant for Allied small arms, including the British 0.303 inch rifle. After the war the process was acquired for the Royal Ordnance Factories; a good deal of work was done by the Explosives Research and Development Establishment to improve the ballistic stability of the final product and to devise means of obtaining the sizes, in the upper part of the range 0.01 inch (0.25 mm) to 0.04 inch (1.02 mm) dia, required for the 30 mm Aden gun. However, after lengthy trials it was decided that the product was less suitable for modern small arms (mainly on grounds of ballistic stability in hot climates) than other newly-developed small-arms powders generically described as NRN (see para. 15). Consequently, for this and other reasons the future of Ball Powder in the British Service is uncertain.

14. Thus, it is not necessary to give here any more detailed description of the basic Ball-Powder process. But it may be convenient to indicate the methods by which the 'base grain' was converted into a powder of more or less acceptable ballistic properties. Obviously, if it was desired that the grain composition should contain nitroglycerine, this could be obtained by adding to the lacquer in the pan a solution of the appropriate weight of NG in solvent. But small additions of NG could also be made by agitating a suspension of the NC base grain in water with NG at, say 60°C, when the NG would be absorbed, the surface layers of the grain being, at least initially, richer in NG than the interior. A similar method could also be used to apply to the surface layers a coating of a relatively non-inflammable moderant, for example, DBP or carbamate or the more inflammable moderant DNT; these moderant coatings cause the initial stages of combustion to proceed more slowly than the later stages (when the surface area of the grain is smaller), thus producing a more even pressure-time curve for the gun. (Unmoderated grains are said to burn 'regressively', that is, less gas is produced as the combustion of the grain proceeds and the area of burning surface decreases.) Another operation could be effected on the finished grain if it was desired to increase its burning rate slightly: it could be flattened by a light rolling, thus increasing its surface area and giving a more uniform burning thickness ('web') by preferential flattening of over-sized grains.

#### NRN (Nobel's Rifle Neonites) powders

15. NRN powders (or, more fully, Nobel's Rifle Neonites) were developed by the Nobel Division of Imperial Chemical Industries Ltd., and perfected under Service contracts to meet the requirements of small arms generally and, more recently, of high-rate-of-fire machine guns. They are single-base powders, employing a mixture of nitrocelluloses (25% nitrocellulose with N = 12.6% and 75% nitrocellulose with N = 13.4%) partially gelatinized by ether/alcohol and stabilized by 1% diphenylamine; they may contain additions of tin (either metallic or as an organic compound) to reduce fouling of the gun barrel, and potassium sulphate to reduce flash. They are produced either as flake or as chopped single-hole tubular grains, either of which products may be moderated by surface coatings of methyl centralite (see Chapter 6) alone or in conjunction with dibutyl phthalate. They are usually

## RESTRICTED

graphited to make them free-flowing in the filling machines as well as to improve their bulk density and to reduce 'static' hazards. The flake form is becoming obsolete.

16. NRN No 41-FN/B is for use in 7.62 mm ammunition; it is a moderated tubular powder having a web (that is, 'wall' thickness) of 0.013 in (0.33 mm) and a length of 0.05 in (1.27 mm); its bulk density is about 900 g/litre. NRN No 141 is a similar powder for 20 mm ammunition, having a web thickness of 0.020 in (0.51 mm), a length of 0.085 in (2.16 mm) and a bulk density of 950 g/litre.

17. In order to obtain a more energetic propellant a small proportion (up to 8%) of nitroglycerine is incorporated with NRN compositions to give the NNN (Nobel's Nitro Neonite) powders. This renders it necessary to use ethyl centralite ('carbamite') as stabilizer in place of diphenylamine (which is too basic to be compatible with nitroglycerine); otherwise these powders are processed in a manner similar to that used for the NRN powders, surface moderation being obtained by coating with methyl centralite alone. NNN powders are manufactured in similar sizes to the NRN powders and are particularly useful where propellant-case capacity is low or where heavy projectiles are used.

18. A faster-burning propellant of the NNN type is obtained by making the powders porous. This is done by incorporating into the composition a proportion of a water-soluble salt and (after extrusion, cutting, and drying to recover solvent) leaching out the salt by soaking ('steeping') the grains in warm water. These powders are known as NPP (Nobel's Parabellum Powder). They are in the form of small discs, not surface moderated but treated with graphite; their porosity can of course be varied. NPP No 30 is used in 7.62 mm blank ammunition and has a diameter of 0.045 in (1.14 mm), thickness 0.0075 in (0.19 mm) and bulk density 500 g/litre.

### Double-base propellants

#### General

##### *Cordite (manufacturing development)*

19. Table 1 lists some British cordites and gives some of their physical characteristics. Cordite was the first type of double-base propellant employed in the British Service, and it was soon used in all then-existing guns and rifles, being produced in appropriate sizes to meet the varying ballistic requirements.

20. It was at first made by mixing dry guncotton (13% N) with nitroglycerine and incorporating this dry 'paste' in the presence of acetone as a gelatinizing solvent; it contained a proportion of mineral jelly, which was at first added in the belief that it would lubricate the bore of the gun but which it was soon realized was a good stabilizer. The original (Mark 1) cordite contained 58% of nitroglycerine (see Table 1) and was soon found to be too 'hot' and to erode the gun barrel excessively. It was therefore succeeded by cordite MD (modified cordite) which contained only 30% NG, and this remained the Land Service cordite until between the two World Wars, when cordite W was introduced to take advantage of the superior stabilizing and gelatinizing properties of carbamite which completely replaced the mineral jelly content. Tremendous quantities of a tubular MD cordite (MD5-2) were used as the propellant in the 0.303 rifle cartridge, for which purpose it was later replaced by CD/T (tubular) propellant which contained 0.5% carbamite. MD cordite was very stable in temperate climates, at least one sample having been found of good stability after 30 years' temperate storage. During the Second World War there was a period when carbamite was in short supply, and cordite WM (in which two-thirds of the carbamite was replaced by mineral jelly) was introduced temporarily in place of cordite W, just as in the First World War shortage of acetone had caused the temporary adoption of cordite RDB in which a nitrocellulose of 12.2% N-content had been plasticized using ether alcohol.

21. Following the First World War, two major lines of development occurred. The first was the adoption by the Royal Naval Cordite Factory, in association with the Research Department, Woolwich, of a process for manufacturing cordite which did not require the use of solvent, and the second was the development of a 'flashless' cordite by the Research Department, Woolwich.

22. The solventless cordite process (see below), during the development of which carbamite was adopted as a Service stabilizer and wood cellulose received approval as a replacement for cotton, has the following principal advantages:

- (1) no volatile solvent being used, the cordite requires no stoving: thus the final cords are not subject to shrinkage after extrusion and can be of very uniform dimensions; this contributes to consequent regularity of ballistics as well as improved filling into cartridge cases or of loading as BL (breach loading) charges
- (2) dry nitrocellulose, with its attendant risks, is not employed
- (3) cordite of large diameter can be made, as no problems of solvent removal arise.

**Table 1**  
**Some British Cordites**

Name	Percentage Composition				Percentage N in NC	cal per gramme	ml of gas per gramme	Ignition Temp °C	Temperature of explosion K	Calculated percentage of CO + H <sub>2</sub> in muzzle gases	Notes
	NG	NC	Stabilizer, etc.								
<b>Cordite Mk. I</b>	58	37	5	Mineral Jelly	13.1	1225	890	160	3675	42	Brown and soft
<b>Cordite MD</b>	30	65	5	Mineral Jelly	13.1	1025	940	160	3215	54	MD is brown, as are early lots of W
<b>Cordite W</b>	29	65	6	Carbamite	13.1	1025	910	153	3305	53	
<b>Cordite WM</b>	29.5	65	2 3.5	Carbamite Mineral Jelly	13.1	1015	934	163	3220	54	
<b>Cordite RDB</b>	42	52	6	Mineral Jelly	12.2	995	959	155	2900		
<b>Cordite CDT</b>	30	65	0.5 4.5	Carbamite Mineral Jelly	13.1	1035	935	ca.160		53	'CD' cordite. 'T' tubular. Small tube for small arms
<b>Cordite SC</b>	41.5	49.5	9	Carbamite	12.2	970	957	154	3090	59	Golden orange. Very smooth and regular
<b>Cordite HSC</b>	47	49.5	3.5	Carbamite	12.2	1175	866	164	3625	42	Hotter SC for small chambered automatic guns. In tubular form
<b>Cordite N (Army)</b>	19.0	18.7	55 7.3	Picrite Carbamite	13.1	755	1058	165	2425	54	White, brittle and opaque
<b>Cordite NF or MNF (Navy)</b>	21	16.5	55 7.5	Picrite Carbamite + Potassium sulphate*	12.2	755	1066	165		55	
<b>Cordite NQ (Army)</b>	20.6	20.8	55 3.6	Carbamite	13.1	880	1001	165	2795	44.5	As for N and NQF
<b>Cordite NQF or MNQF (Navy)</b>	21	21	55 3	Picrite Carbamite + Potassium sulphate	12.2	880	1002	165		44	

\* or Sodium Cryolite

RESTRICTED

RESTRICTED

*Muzzle flash*

**23.** Reference has been made in Chapter 2 and para. 6 and 7 of this Chapter to the problem of 'flash' at the muzzle of guns. It has a high 'nuisance value' from the Service standpoint because it discloses the position of the gun to the enemy, especially at night, and at the same time tends to 'blind' the gun crew by its brightness, so that they have difficulty in seeing to perform such operations as range-finding, fuze setting, etc. Yet flash is, in greater or lesser degree, an inevitable concomitant of the combustion of propellants containing carbon and hydrogen in the molecular structure of their ingredients. If the composition of the propellant and the conditions in the gun were such that all carbon was completely burnt to  $\text{CO}_2$  and all hydrogen to water, no 'combustion' flash should occur although a shock-wave flash might be produced. But, in fact, such a propellant would be too 'hot' to be practicable and would cause excessive gun erosion (a serious problem, anyhow, in high-rate-of-fire guns) and the conditions in the gun tend to cause a degree of 'imbalance' in the combustion products. By the time a propellant is 'cool' enough to be acceptable on erosion grounds, the gases leaving the muzzle contain not only carbon monoxide but even hydrogen and may yet be hot enough to ignite on meeting the air at the muzzle, giving the large glowing 'cloud' which may be seen in photographs of guns fired at night.

**24.** As stated in para. 7, some alleviation of this problem may be obtained by the addition to the propellant of a potassium salt: it had been found in academic studies of the combustion of carbon monoxide and hydrogen in presence of air or oxygen that potassium (and sodium) salts inhibit the chain of reactions leading to the end-products. In addition, numerous attempts were made to cool the muzzle gases to a temperature low enough to prevent them igniting; numerous ingenious devices were proposed to inject water into the gases, some of which were fairly effective, but none of them was practical from a Service standpoint.

A study of the behaviour of various propellants in guns of small calibre had shown that nitrocellulose propellants of calorimetric value *ca* 820 cal/g (water liquid) were generally flashless, whereas cordite MD (1020 cal/g) gave a full flash. So the way was pointed to the development of cool propellants, provided that the difficulty of their giving rise to increased proportions of carbon monoxide and hydrogen could be overcome.

**25.** Analysis of the gases from the calorimeter bombs in which the above calorimetric values had been obtained showed that the NC powder gave 68.2% ( $\text{CO} + \text{H}_2$ ) and 11.1%  $\text{N}_2$ , while cordite MD gave 53.8% ( $\text{CO} + \text{H}_2$ ) and 12.1%  $\text{N}_2$ . Further work on these lines confirmed that a low calorimetric value was even more important in avoiding the occurrence of flash than was a relatively low proportion of inflammable gases. But if the nitrogen content of the gases could be increased (at the expense of the inflammables) at the same time as the calorimetric value was reduced, an all-round gain should ensue. The means to this end were found when it was discovered that nitroguanidine ('picrite'), rich in nitrogen (Chapter 6) and of calorimetric value about 720 cal/g, was not only compatible with cordite but was actually beneficial to its stability even when carbamite was present, so that the 'life' of propellants containing both picrite and carbamite is well in excess of 25 years, whereas the 'life' of a non-picrite gun propellant stabilized with carbamite is rather less than 25 years; both 'lives' being related to a temperature of 32°C.

**26.** Early gun trials showed that it would be necessary to employ 50% or more picrite which, being insoluble in the plasticizer, had to be produced in very fine crystal form in order to give a propellant of good density; eventually a picrite content of 55% was chosen for a range of Service propellants, of calorimetric value from 755 to 880 cal/g, which gave  $\text{CO} + \text{H}_2$  proportions from 45% to 55% and nitrogen from 27% to 29% in the calorimeter gases. It was found that even these propellants were not sufficiently flashless in some of the larger guns, and recourse was had to the addition to the propellant composition of 0.3% sodium cryolite (the cryolites are aluminofluorides; the sodium salt,  $\text{Na}_3\text{AlF}_6$ , occurs in nature).

**27.** If the calorimetric value of a gun propellant composition is reduced much below about 800 cal/g the ballistics may tend to become irregular, apart from the appearance of difficulties of ignition and of increase of required charge weight. However, with adequate gun chamber capacity and carefully designed ignition, it has been found possible to use cooler propellants; thus a composition of calorific value equal to 560 cal/g is used in the Naval 3-inch and 4.5 inch Mark 8 guns.

**28.** From what has been written it will be realised that the propellant composition is only one factor in the flash problem: something depends on the design of the gun (for example, barrel length, weight of projectile, chamber and muzzle pressures), and brief reference may be made here to the addition to the muzzle of the gun of the flash suppressor, a device whereby the muzzle gases are rapidly expanded (with adiabatic cooling) before they can set up shock waves which would give rise to flash.

*Smoke*

**29.** Before leaving this general section on double-base propellants it is convenient to refer to another Service problem, that of 'smoke'. In the Services, smoke is considered as undesirable as flash. In gun smokes the main constituent is water which has condensed on particulate matter, mostly arising from the igniter composition (for example, potassium salts from gunpowder igniters). But smoke may be enhanced by the carbon which is a concomitant of the combustion of systems containing carbon and hydrogen in their structure. It has been said that the gaseous products of combustion of a propellant

include carbon monoxide and hydrogen in addition to the nitrogen, carbon dioxide and water which would be expected; there may also be methane,  $\text{CH}_4$ , under some conditions (for example high density of loading of the propellant in the gun).

30. All the following reactions can occur to give rise to carbon as the above products of combustion cool:



These reactions, occurring for the most part outside the weapon, have not been found amenable to favourable modification, and the most the propellant chemist can do is to choose a propellant giving the best compromise between flash and smoke when used in the weapon (whether gun or rocket) under its conditions of operation, and to avoid as far as possible the introduction into the system of other sources of smoke, for example, gunpowder in igniters. In rocket motors employing double-base propellants the nature of the ignition system is of less importance from the standpoint of smoke, because the igniter products are ejected in the first few milliseconds (before the rocket has travelled far).

### Solvent cordites

#### *Drying guncotton*

31. It has been stated in para. 20 that in the early days of cordite development dry guncotton was mixed with nitroglycerine as a first step in the process. Dry guncotton is a dangerous material in itself and the operation of adding NG to it was also attended with danger. At first, quantities of wet guncotton as large as 5000 lb (2.27 Mg) were stoved (dry weight of guncotton is 3500 lb, 1.59 Mg), but in the First World War the introduction of the Quinan stove permitted the more rapid drying of smaller quantities in separate compartments of a stove building. The Quinan drier was essentially a horizontal wire gauze covered with a cloth on which quantities of only 25 lb, 11.34 kg, (dry weight) of GC were placed to be dried in a current of warm air passing upwards. But however the GC was dried it was necessary to weigh out portions of it into rubberized canvas bags, add measured portions of NG and work the mixture into a crude dough or 'paste' by hand, partly in the bag and partly on a lead-covered mixing table, before it was transferred to the incorporator.

#### *Manufacture of NC/NG paste*

32. The introduction of the solventless cordite process (see also para. 41 and 46) led to the adoption for the solvent process of the wet mixing of GC and NG. In this operation a known quantity of an aqueous slurry containing a known weight of GC is pumped through a small vessel, known as a tundish, where a known weight of NG is sprayed into it. The mixture passes steadily from the tundish to a stirred tank, where a homogeneous slurry of GC/NG forms, and is then fed on to a papering (or de-watering) machine (similar to those used in the paper-making industry), see Fig. 1, in which a continuous band of cloth passes over suction rolls, and then under a weighted roll to consolidate the sheet of pulp formed on the cloth, and to an automatic breaker which deposits fragments of GC/NC pulp in aluminium trays. These trays are loaded onto racks in an open-ended truck which is taken to a hot-air drying house. Thus a dried paste, ready to go to the incorporator, is produced with reduced explosive risk and without the use of manual operations.

33. The incorporator is a machine very similar to that used in the baking industry for making bread dough. In a rectangular jacketed pan, the bottom of which is shaped in the form of two semi-cylinders side by side, two four-bladed horizontal impellers revolve slowly (one at 5.5 rev/min and the other at 11 rev/min) in opposite directions, so that the contents of the pan are carried up the sides, over to the middle and down again. The shearing action on the dough in this machine causes heating and consequently cooling water must be passed through the jacket. As the machine is loaded with about 500 lb (227 kg) of dough a measured volume of acetone/water (90/10 by volume) is sprayed on to assist the gelatinization of the GC by the NG (92/8 acetone/water has optimum gelatinizing effect; 82/18 is the lowest practicable ratio). After half an hour the machine is stopped and additives, such as stabilizers, are weighed in; incorporation takes place for a further 4 to 6 hours, depending on the composition.

34. When incorporation is complete the machine is stopped and mechanically tilted and the blades are run in reverse to unload the dough; the unloaded dough is transferred in bags to the Press House where it is cut into suitable pieces to load into the cylinders of the vertical presses. The presses may be fitted with one or more steel dies in a die-plate, between which and the cylinder is a perforated steel 'choke' plate supporting a 50-mesh copper gauze to 'strain' the dough as it is pressed at 600 lb/in<sup>2</sup> (4.14 MN/m<sup>2</sup>) to 1500 lb/in<sup>2</sup> (10.34 MN/m<sup>2</sup>). From the dies the cords are drawn by hand on to a long table where they are straightened and cut to length before being put on drying trays, see Fig. 2; with the fine tubular rifle cordites (for example, CDT 5-2 which has 0.05 in od, 1.27 mm, and 0.02 in id, 0.51 mm), however, the

ords are wound onto brass reels as they leave the mechanical screw press and these reels are sent to stoving. Drying is at 40°C for a time up to several weeks, depending on size; however, up to 1% of volatile matter (VM) may remain, but the VM of picrite cordites must not exceed 0.22%.

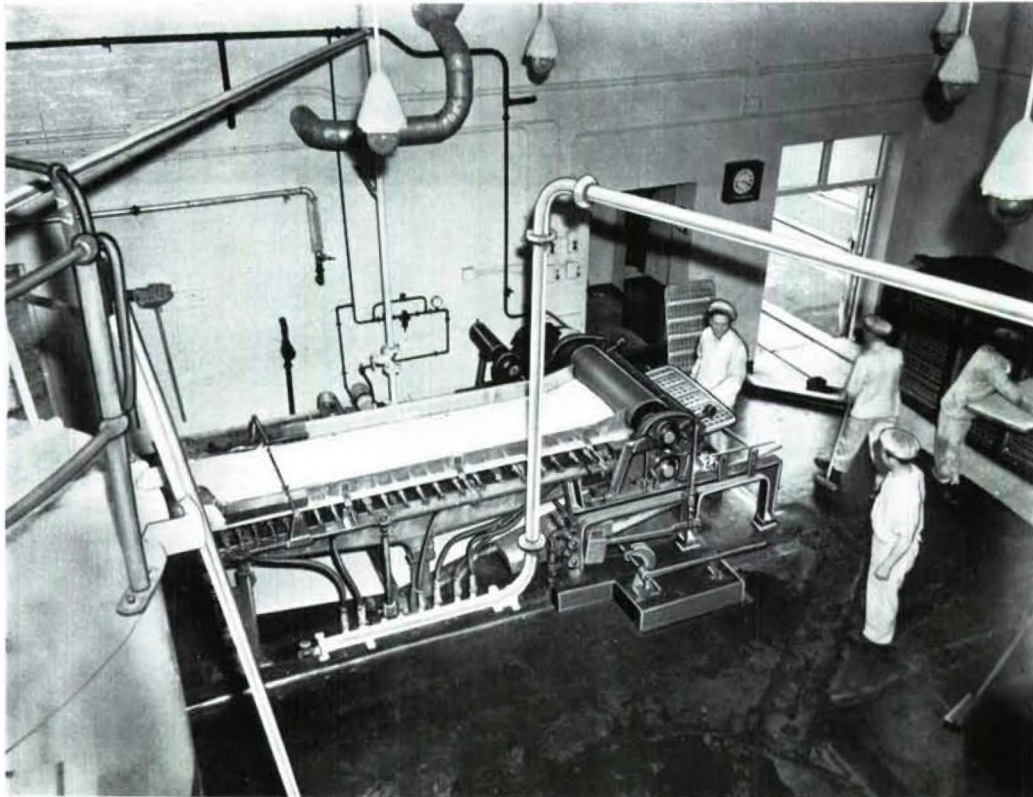

Fig. 1 Dewatering of GC/NG slurry

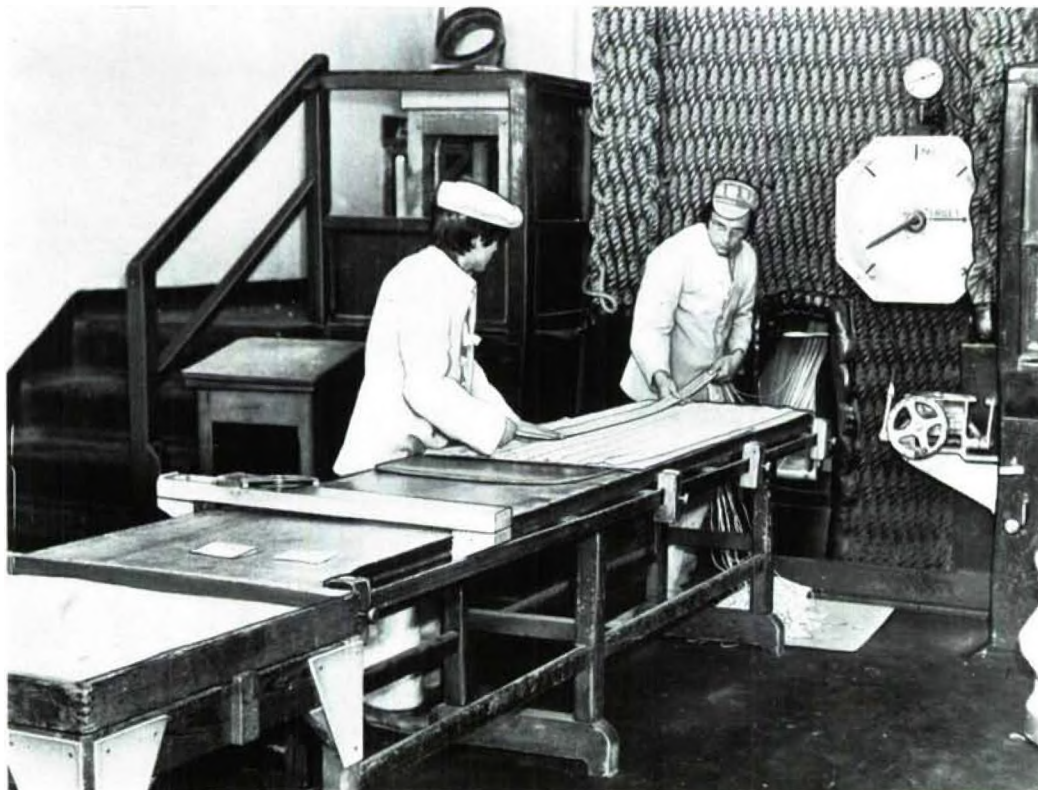

Fig. 2 Cutting extruded propellant strands

35. The waste arising in the Press House (from dough-cutting and from 'heels' left in the cylinders) is reincorporated with a little solvent to compensate for losses, and added to new batches of dough during their incorporation as an aid to the production of homogenous, well-mixed material.

36. When a flashless propellant (known in America as a 'triple base propellant') is being made by this process the appropriate weights of GC/NG paste and picrite are loaded into the empty incorporator together with the acetone/water solvent and incorporated for half an hour before addition of ground carbamite and any other ingredients.

37. Because the weight of cordite for a gun charge is determined by firing proof on a sample taken from a 'lot', 5000 lb to 50 000 lb (2.27 Mg to 22.7 Mg) of propellant, great care is taken at every possible stage in the manufacture to blend the products of batches, and finally, before final inspection, to reblend the lot.

#### *Semi-solvent process*

38. The process described in para. 32 to 37 gives flashless cordites of good density and dimensional regularity only with difficulty, especially in the larger sizes, and to overcome these difficulties another feature of the solventless propellant process was introduced, that is, hot rolling. Cords made as described above are first truck-dried to a solvent content of 4 to 5% and these cords are then passed through rolls at 35°C to form sheets containing only about 2% solvent, which are then cut into discs to be loaded into the press cylinders, whence the final cords are extruded at a temperature of about 65°C and stove-dried as before. This modified process is known as the 'Semi-solvent Process' and it gives chords of greater flexibility, natural straightness and surface smoothness which can therefore be more readily made up into charges\*.

#### *Picrite-carbamite complex*

39. Brief reference must be made to a problem peculiar to the picrite (flashless) propellants which arose during the Second World War. At one plant it was decided to add the carbamite to the wet mix of GC and NG instead of to the cordite paste in the incorporator; however, this led to higher rates of burning in the final propellant, and this effect was correlated with a lower, and variable, density of the propellant. It was found that in the wet-mixed-paste process there were coarse crystalline agglomerates in the final mix which consisted of an equimolecular compound of picrite and carbamite. This compound, which melts at 90°C, is (unlike carbamite) insoluble in benzene. It is, of course, present in picrite cordites made by the process in which the finely ground carbamite is added to the premixed paste in the incorporator, but it is there in the form of a well-dispersed micro-crystal which does not cause irregular ballistics.

#### *Ballistite*

40. Finally, reference should be made to Ballistite which may be regarded as a special form of 'solvent cordite'. As originally invented by Nobel in 1888 it was intended as a shot-gun propellant, and it is still so used; but it is also employed nowadays in the primary charge for mortars (the secondary charge is usually an NRN powder). The modern composition is:

	Nitrocellulose (12.65% N)	60.0	parts	by	weight
	Nitroglycerine	38.0	..	..	..
	Carbamite	0.5	..	..	..
	Potassium Nitrate	1.5	..	..	..
Plus:	Chalk	0.15	..	..	..

The NG and NC are wet-mixed and dewatered, but the paste is 'matured' for a week before drying. The dry paste is incorporated with the carbamite, chalk and potassium nitrate (17.5%), in presence of acetone, to yield a dough which is rolled at 55°C to 60°C into a sheet of precise thickness; the sheet, after trimming and maturing overnight, is cut into square flakes from which most of the potassium nitrate is leached out in water, to give porosity. After drying and sieving, the flakes are graphited (0.6%), sifted, blended and lotted; they are 0.06 in (1.52 mm) square and 0.008 in (0.20 mm) thick. Ballistite has a calorimetric value of about 1250 cal/g, and is too hot (and therefore erosive) for use in guns (cf the calorific values of cordites in Table 1).

#### **Solventless cordites**

##### *Manufacture*

41. The process by which the solventless cordites are made is basically that employed by Nobel in 1888 to make his Ballistite (see Chapter 2 — Note: the modern ballistite is made using a solvent, which is

\*Cordites made by the semi-solvent process are characterized by the prefix M; thus cordite MNL/F/2P (560 cal/g) is made by the semi-solvent process, contains picrite (N), is cool (L) and flashless (F) by reason of the presence of 2% potassium sulphate (2P); cordite MNQF is hotter (880 cal/g) than MNF (755 cal/g).

removed on hot rolls), and presumably it was only doubt about the safety of applying it to the manufacture of cordite which hindered its earlier adoption. It was developed in the British Service for Naval cordites, SC and HSC, based on wood nitrocellulose of 12.2% N. A 10% suspension of NC in water is pumped through a tundish into which the requisite amount of nitroglycerine is sprayed (see also para. 46 where the tundish method has been superseded). A tundish is a 3-turn spiral open channel, and is made by welding onto a flat circular plate a 3-turn spiral of strip with a 3 to 4 inch spacing between turns. The NC slurry enters the circular central 'compartment', and the NG is added in the second turn. The mixed slurry leaves the third turn to enter a stirred mixing vessel where carbamate, chalk and candelilla wax (to effect more easy and regular extrusion from the press die) are added; the operation of filling the vessel takes upwards of 12 minutes during 10 of which the NG is fed to the tundish. Vigorous stirring is maintained for half an hour, after which the slurry is fed to the papering machine (see para. 32) to remove the water and form a sheet about half an inch thick.

42. The crumbly, oatmeal-like cake from the machine is dried for 20 hours on aluminium trays in stoving trucks in a current of air at 45°C, after which it is passed through a pair of even-speed rollers at 55°C; in the course of five passages through these rollers the sheet is further dried and is gelatinized, that is, the fibrous structure of the NC disappears as the NC is swelled by the NG and carbamate, even though as much as 49.5% NC is used in cordite SC. If gun cordites are to be made it is usual to cut the sheets from the rolls into discs to load into the press, but if large-size cordites are required it is customary to roll the sheets (cut into strips 6 to 10 in wide) into 'carpet rolls' and load them into the press in this form.

43. Because the gelatinized composition behaves as a true thermoplastic (that is, it softens on heating and hardens on subsequent cooling) it is convenient to press it at a temperature of 45°C to 70°C, see Fig. 3 and 4, using an extrusion pressure of about 4000 lb/in<sup>2</sup> (17.8 MN/m<sup>2</sup>) to 7000 lb/in<sup>2</sup> (31.1 MN/m<sup>2</sup>) (cf the 600 lb/in<sup>2</sup>, 2.7 MN/m<sup>2</sup>, which may be adequate for a non-pieric solvent cordite); before pressing begins the press cylinder is evacuated to remove air which might otherwise appear as inclusions in the cordite.



Fig. 3 Heating carpet rolls (by dielectric means)

44. The processes of rolling and pressing are attended with some fire risk. As the rolls must be attended by an operative, devices have been introduced to provide remote handling, while above the rolls an electrically operated drencher, to operate a drencher. The press, however, need not be operated by remote control from another compartment or from outside, the progress of the operation being watched by closed-circuit television if necessary.

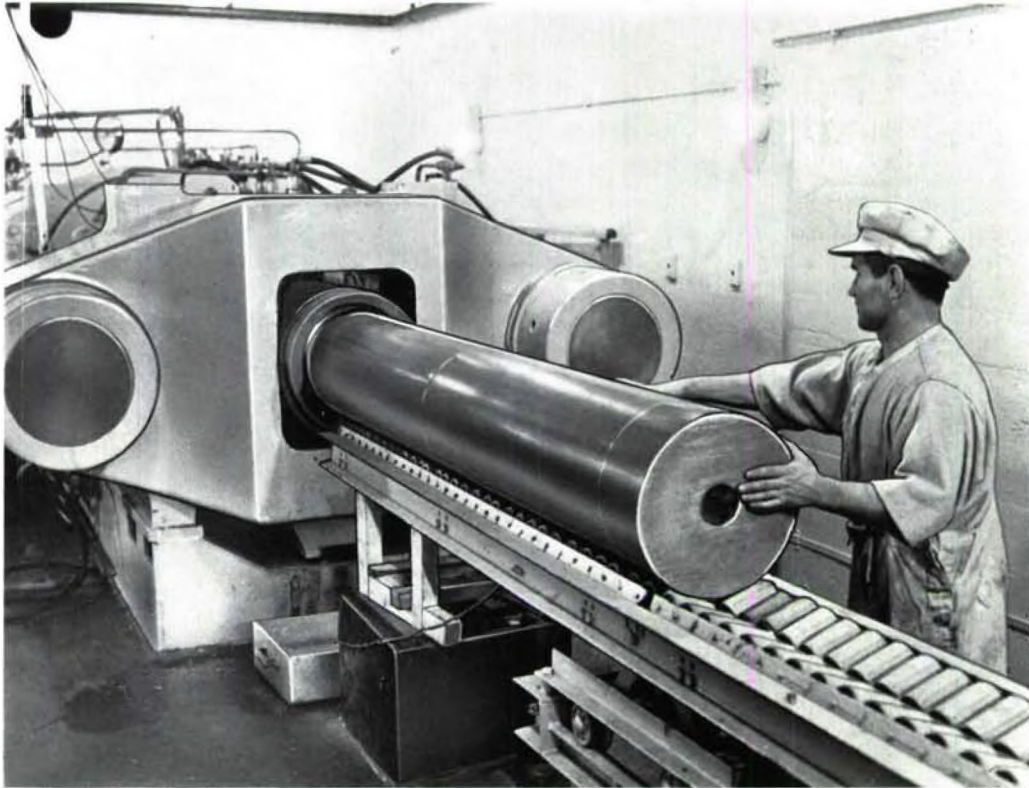

Fig. 4 Extrusion of propellant from hydraulic press



Fig. 5 Examples of various solventless cordite extrusions

*Advantages of solventless method of manufacture*

45. Apart from the advantages mentioned in para. 22 it will be seen that this process requires less plant than the solvent process — notably there is an absence of cordite stoves, which take up a lot of land — and it will be appreciated that as the final cordite does not require to be kept for weeks at an elevated

temperature to remove solvent its Service 'life' is in some degree improved since some degradation of the nitric esters is bound to occur during the stoving of solvent propellants. On the other hand, it is not possible effectively to 'strain' solventless cordite during processing, so that great care has to be exercised to ensure that foreign matter does not get into the material at any stage of the process. Examples of various solventless propellant extrusions are given in Fig. 5.

46. It is remarked in Chapter 12 that a great incentive to the adoption of the continuous process for the manufacture of nitroglycerine is that there is at any time only a small amount of nitroglycerine in the plant. But much of this advantage is lost if the washed and purified product must be accumulated in batches before passing on to some other manufacture, such as that of cordite. Accordingly, a great deal of work has been done in the Royal Ordnance Factories in recent years to render the mixing of NC slurry and NG a continuous process, operating in phase with the continuous NG plant. Basically this would call for the maintenance in a pump-fed ring main of an aqueous suspension of NC of constant composition which could be tapped and metered at the appropriate rate to a battery of mixing vessels together with the NG emulsion in water. In the present state of the art the process (which has superseded the NG truck and tundish system, see para. 41) is to transfer automatically weighed charges of NG, emulsified with water in a jet pump, directly into the requisite amount of NC slurry in one of a sequence of mixing vessels. The process is thus a semi-continuous one.

### Cast-double-base propellants

#### *Manufacturing considerations*

47. In para. 9 a description has been given of the process by which nitrocellulose is gelatinized and converted to granular powders. In para. 32 and 41 it has been shown how two processes have been developed to gelatinize nitrocellulose in presence of nitroglycerine, essentially by doing mechanical work on the mixture, either aided by solvent in an incorporator or on heated rolls, and it has been pointed out that the second ('solventless') cordite process can be employed to produce cordite of 'large' diameter. In fact, however, the diameter of cordite which can be made by the solventless process is conditioned by the size of the extrusion press, which can soon become a massive piece of equipment, costly to make and to house. The first 'solventless' presses had a 10½-inch (267 mm) cylinder, and when these were found to work satisfactorily, and the need for larger cordites grew, they were followed by 15-inch (381 mm) presses. These two sizes of press were adequate to make the cordites required for 2-, 3- and 5-inch rockets in Service during and since the Second World War.

48. Following the Second World War, diameters of potential missiles increased and larger cordite sizes were produced using 22½-inch (571 mm) presses and specially designed ('long parallel') dies. But it was difficult to produce satisfactory cordite having a cross-sectional area greater than about 40% of that of the press cylinder, apart from problems (a) arising from the need to stop the pressing to reload the cylinder and (b) of keeping a large 'cord' straight while it cooled. So the question arose whether, since it was difficult to extrude large charges, they could be cast, and it became apparent that the answer might be to fill a mould with (pre-gelatinized) nitrocellulose powder, flood it with desensitized nitroglycerine and keep it at an elevated temperature until a homogeneous mass was formed — all rather analogous to making a rice pudding. In fact, this was found to be feasible, using an elevated temperature for 'curing' of about 60°C for a time (a few days, depending on the size of the mould) and this method is the basis of the cast-double-base (CDB) process.

#### *Advantages of the casting process*

49. Before describing this process in more detail it will be convenient to discuss one or two other features besides its suitability for making large propellant charges which give it advantages over an extrusion process. It soon became a requirement of large cylindrical charges for rocket motors that they should have one or more holes parallel to their length. Extrusions could be made with one axial hole of not too complicated cross-section, for example, plain cylindrical or star-shaped. But if more than one hole was required, or if the shape was too complex (for example, a modified clover leaf) and particularly if an unsymmetrically placed or a tapered hole was needed, extrusion was impractical. But any requirement can be met by the casting process, since the mould can readily be fitted with formers to produce the holes (provided that a web-thickness of not less than about ¼-inch is retained).

50. Again, when the need arose for charges with holes there was a requirement in most instances that the charge should burn only on the surfaces of those holes, which meant that the other surfaces had to be inhibited, that is, covered with a (relatively) non-combustible material, usually cellulose acetate or ethyl cellulose. With an extruded cordite charge this involved a tedious process of pasting onto the appropriate surfaces thin layers of 'inhibitor', or of shrinking on an ethyl cellulose tube, whereas in the casting process it was necessary only to line the wall of the mould with preformed inhibitor, to which the propellant would adhere; cellulose acetate was a suitable material as the surface was partially gelatinized by the desensitized NG casting liquid during the 'curing' stage. Yet again, as missile design advanced there was a requirement to avoid 'waste' space in the rocket motors, and this could best be met by dropping the use of loose, externally inhibited charges and employing charges designed to adhere to the walls of the motor. This requirement, too, could be met by adapting the casting process to use the

rocket motor (suitably coated internally) as the mould in which the charge is cast. But it must be said that although the CDB process can advantageously be used to meet the 'engineering' requirements of inhibition and case-bonding of double-base charges, those requirements themselves contain a 'hidden' difficulty, namely that of meeting them not only at the outset but throughout an acceptably long Service life. This is discussed further in Chapter 12.

#### *Description of CDB process*

**51.** The CDB process will best be understood if a description is given of it as it was practised in the Explosives Research and Development Establishment about 1951. It employed a nitrocellulose (12.6% N) 'casting powder' in the form of small cylindrical granules, 0.035-inch (0.90 mm) diameter and 0.035-inch (0.90 mm) long; these dimensions had been found by trial to give the best compromise between ease of manufacture, packing density in the mould and time of cure, and are still much used. (Note: Later, when need arose for more energetic compositions, some NG was used in the casting powder.) The nitroglycerine was employed in admixture with triacetin (glycerol triacetate), both for safety reasons and because the composition would have been too 'hot' if only nitroglycerine were used; this 'casting' liquid, which, like the powder, contains stabilizer, was measured into a vessel with a bottom run-off tube and a lid which had a connection to a vacuum pump, so that the liquid could be degassed and dried.

**52.** The casting equipment (Fig. 6), which was made of stainless steel (for cleanliness), consisted of five principal parts which were:

(1) the base was essentially a shallow cylindrical 'box', the upper surface of which had just within its periphery a shallow circular groove and at its centre a shallow spigot-hole to mate with the 'former' (item 3 below); the area between these was perforated to communicate with the interior of the 'box'. The interior surface of the bottom of the 'box' sloped slightly towards a hole in the side to which was welded a short tube, which was connected by a plastics (PVC or polyurethane) tube to the bottom run-off tube of the casting liquid vessel; the plastics tube was closed by a wooden screw-clamp. The base had, welded to its side, three lugs for tie-bars

(2) the main vessel (or 'corset') was a cylinder (about 6 inches (152 mm) id and 24 inches (610 mm) long) which sat on a rubber sealing ring in the groove in the upper surface of the base

(3) the 'former' was cut from the solid to give the required shape of the axial burning surface of the charge required. It was nearly as long as the main vessel and had, at its lower end, a spigot to mate with the base and at its upper end a hole by which it could be gripped to extract it from the finished charge

(4) a perforated plate, to be placed on top of the casting powder; it had a central hole so that it could pass over, and act as upper centring device for, the former

(5) the lid sat on a rubber sealing ring on the upper edge of the main vessel. It was provided with a small window and with a short tube by which it could be connected by a plastics tube to vacuum or atmosphere. On its underside the lid was fitted with four plastics pegs, designed of such a length as to contact the upper surface of the perforated plate (item 4). The lid had three lugs for tie-bars round its periphery.

**53.** In the operation of making a charge, the above items (1), (2) and (3) were assembled together and a cellulose acetate tube fitted inside the main vessel to line its walls. A metal distributor box was placed on top of item (2); this was a cylindrical vessel with a perforated bottom, designed to 'sit' on the upper rim of the assembly, into which the charge of casting powder (weighed by difference) was poured; the assembly and the distributor were connected to a common 'earth', to minimize electrostatic risk as the powder flowed into the assembly from the box. The perforated plate (item 4) was placed on the level surface of the powder, the lid put on and the whole assembly clamped together by the tie bars. The plastics tubes connecting the base to the casting liquid vessel and the lid to the vacuum system were put on and the wooden clamps applied to them. The clamp on the tube connecting to the vacuum was opened, to 'degas' the powder. Meanwhile, the appropriate quantity of casting liquid was put in its vessel and degassed and dried, under vacuum.

**54.** When the degassing operation were complete (in 2 hours, water being condensed in a Drikold trap), the casting liquid vessel was brought to atmospheric pressure and the casting equipment was sealed off from the vacuum system. The clamp between the casting liquid vessel and the base of the casting equipment was then opened gently to admit liquid to the latter until it could be seen to appear just above the perforated plate on top of the charge of casting powder. A second clamp was then applied to the casting liquid plastics tube, and both clamps were closed before the tube between them was cut, thus leaving the casting equipment, with its charge, free to be removed to a stove at 60°C where 'cure' was completed in about 72 to 120 hours.

**55.** During cure the charge, if unrestrained, would 'swell', thus giving a low density; in the equipment as designed this 'swell' was restrained by the spring-effect of the plastics spacing pegs between the upper perforated plate and the lid. After cure the system was allowed to cool before being dismantled, when the charge (and, of course, the former) was retained in the corset (para. 52 sub-para. (2)), from which it

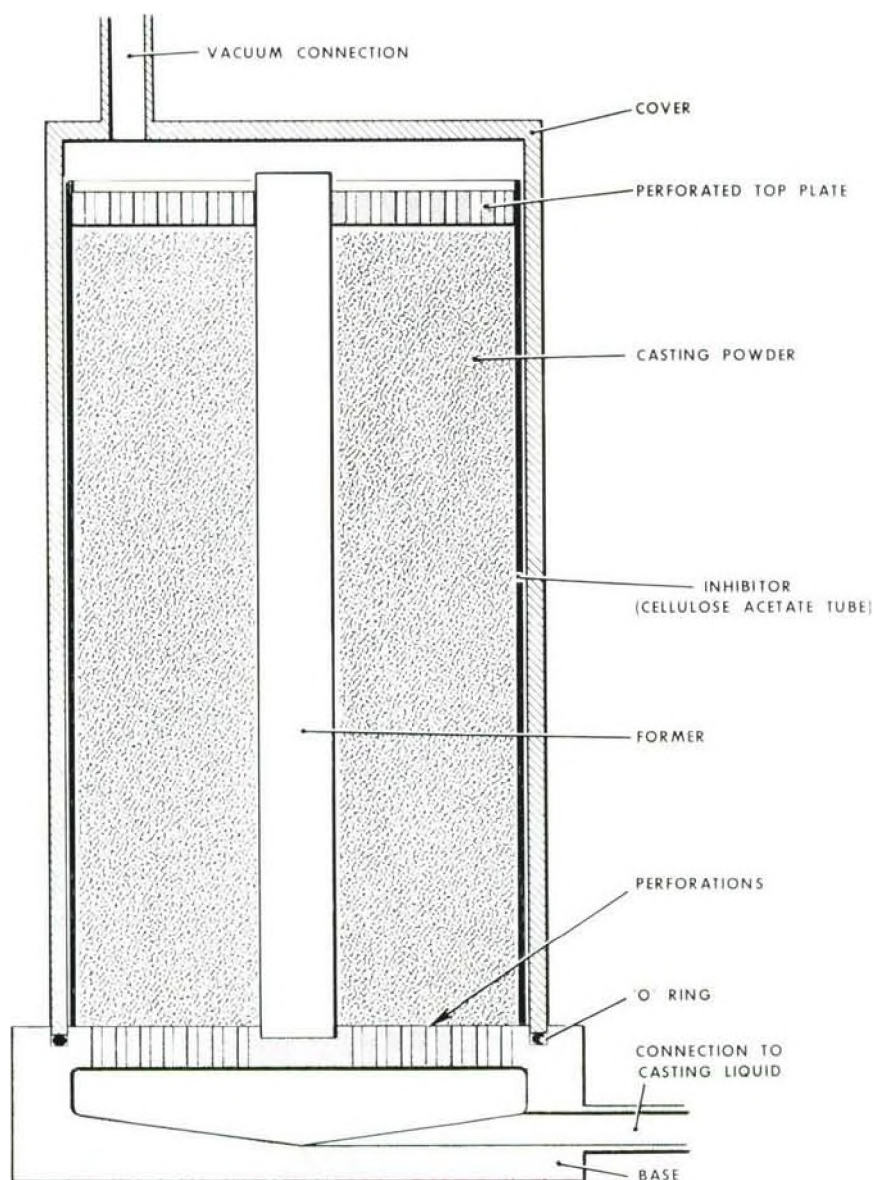

Fig 6 Casting equipment

was readily pushed out together with its cellulose acetate tubular inhibiting sleeve. The charge was then placed in a suitable vice and a jack applied to the former to break its adhesion to the charge, whereupon it was readily removed. The ends of the 6 inch  $\times$  18 inch (152 mm  $\times$  457 mm) charge could then be trimmed and cellulose acetate discs stuck on them so that only the inner surface generated by the former was left as the burning surface.

56. The process remains essentially as described but as charges became larger many improvements were made to the above process; for example, the corset was split to enable it to be separated more easily from the charge; stainless steel was replaced by light alloy in the interests of ease of handling; the former was machined from polythene or polypropylene for improved safety; extruded cellulose acetate tubes were replaced by tubes wound to size from acetate foil; the plastics restraining pegs were replaced by a specially designed flat-coil spring, and more recently a pneumatically loaded plate has pressed on the top of the charge during cure while a pressure of nitrogen has been maintained in the corset (see Fig. 7). Figure 8 shows a casting assembly for a large rocket motor about to be filled with powder.

57. An important aspect of the CDB process is that it lends itself fairly readily to the introduction of modifications in the composition of the final propellant charge. The introduction of minor solid additives (for example, ballistic modifiers — see Chapter 12) can be made during the manufacture of the casting powder, the stabilizer in which can be changed at will. The composition of the casting liquid, within the limits of safety, can easily be varied. Thus a wide range of compositions of varying calorimetric values and ballistics characteristics can be made.

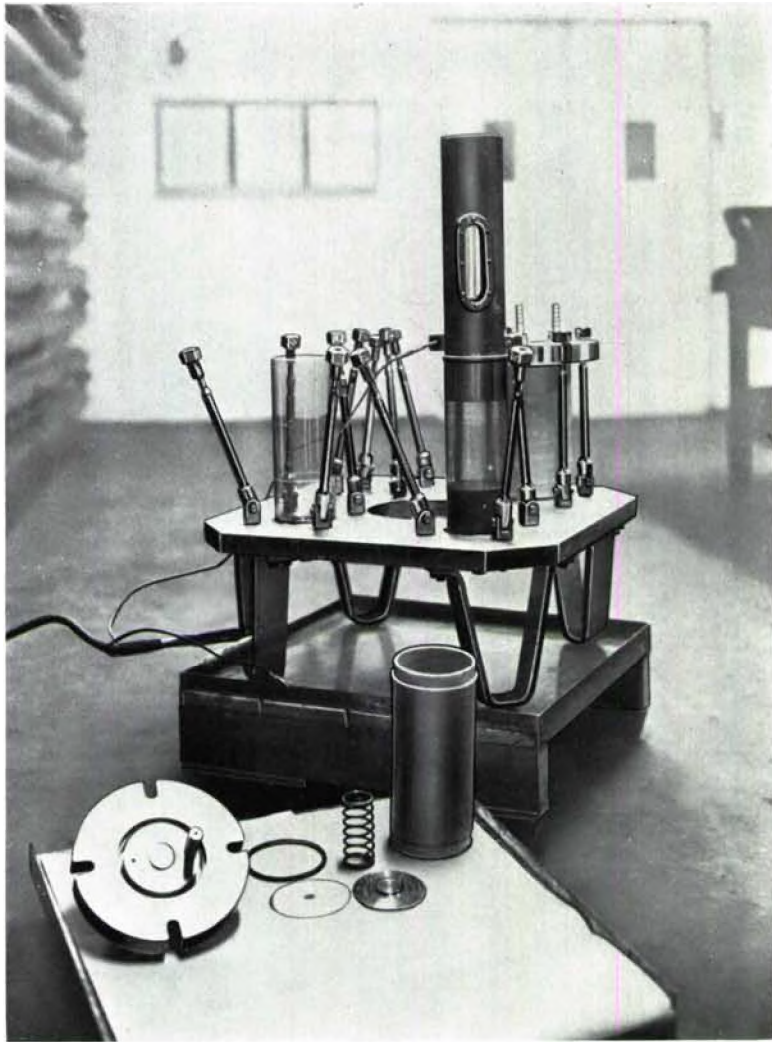

Fig 7 Casting assembly for rocket motor

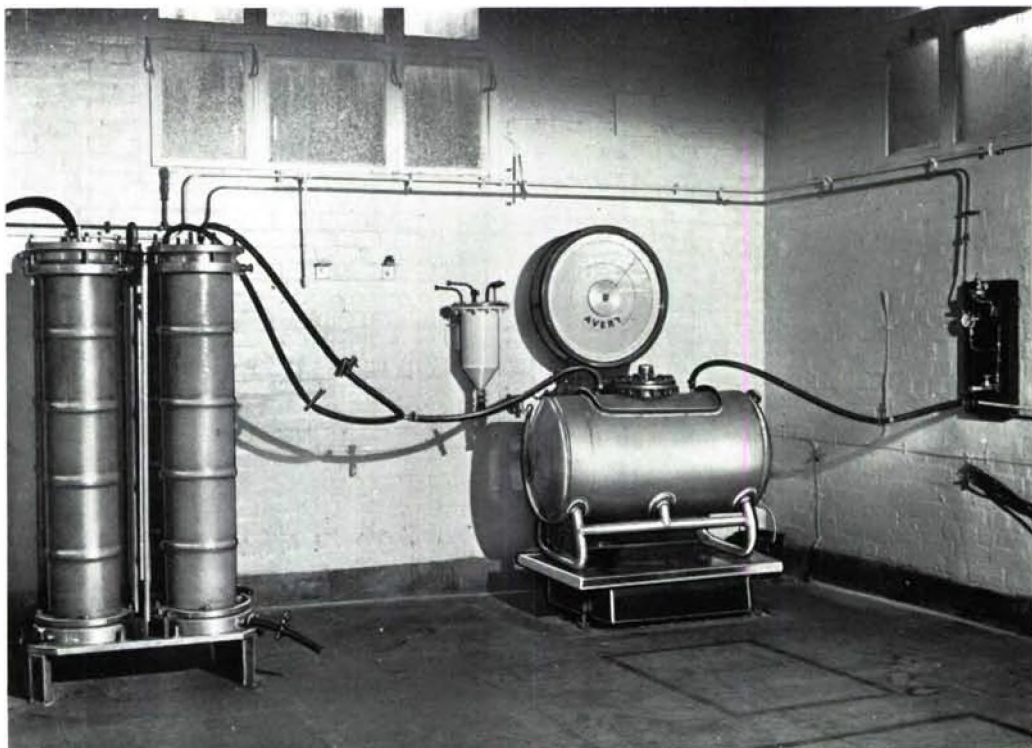

Fig. 8 Casting assembly for large rocket motor about to be filled with powder

**Composite propellants****Choice of materials**

**58.** As stated in Chapter 2, composite propellants are in essence physical mixtures of fuel and oxidant; the first of them was gunpowder in which the prime fuel is charcoal and the oxidant is saltpetre, the sulphur content contributing something as a fuel but more as a bonding agent between the grains of charcoal and of saltpetre.

**59.** Today there is an extensive choice of fuels with more or less favourable physical properties for rocket propellants, largely due to the activities of the polymer chemists in the petrochemical industry, mainly in the USA where the market for synthetic rubbers, *etc* is more 'adventurous'. Clearly the fuel should be as nearly as possible a hydrocarbon molecule, since any atoms such as oxygen, sulphur, nitrogen, *etc* will reduce its available energy of combustion. From the standpoint of physical properties there is the choice between a polymer of fairly low molecular weight which can be incorporated with the oxidant and remain unchanged thereafter or of a low molecular weight material which, after incorporation with the oxidant, can be caused to polymerize to yield a rubbery matrix. But in the latter instance there are considerations that must be borne in mind when choosing the material. Some of these are:

- (1) its heat of polymerization must be modest to avoid risk of inflammation when the polymerization reaction is initiated
- (2) any reagent required for the polymerization process must be compatible with the oxidant and other ingredients
- (3) there should not be a considerable volume change during polymerization. In particular shrinkage should be minimal so that a propellant charge does not break away from its casing
- (4) the final polymer must be intrinsically stable, both in itself and in the overall propellant system. It should never be forgotten that, to put it crudely, molecules which can be 'zipped' together can become 'unzipped', whether by the action of atmospheric oxygen or moisture, or heat, or the agency of some ingredient of a propellant.

**60.** These considerations have 'wrecked' one or two apparently promising rubbery propellant systems— or, at least, have resulted in their having limited Service 'lives', as happened with some polyurethane rubber propellants. However, for very large rocket motors a propellant of rubbery characteristics is desirable, and a vast amount of work has been done in America to search for polymers of optimum characteristics. For the motor of a military rocket in which, for reasons of design, it is required that the propellant charge shall be case-bonded, rather than loose, the propellant composition must be either rubbery or plastic in order to allow for the considerable difference in coefficient of expansion between the material of the motor case and the propellant. In hot climates a rigid propellant would be crushed and in cold climates it would separate from the case — both events giving rise to increased burning surface.

**61.** In the field of solid oxidants the choice is limited to nitrates and perchlorates (mixtures of chlorates with fuels are too sensitive to use) and even with those compounds we are in practice restricted to the ammonium salts since the presence of metal oxides in the exhaust gases of a rocket is undesirable (they use up oxygen which could have been better employed to burn carbon or hydrogen, and they increase exhaust smoke). In fact, on thermodynamic grounds the modern high-impulse propellants cannot use ammonium nitrate but must employ ammonium perchlorate (ammonium perfluorate is not known). However, some American firms employ compositions using ammonium nitrate, alone or in admixture with ammonium perchlorate, for special purposes; but the ability of such compositions to withstand rigorous climatic conditions needs to be carefully considered because of the phase-change to which ammonium nitrate is subject at 32°C, as well as in the light of its hygroscopicity.

**62.** In spite of what has just been said about metal oxides in exhaust gases, the addition of aluminium as a fuel to propellant systems has long been realized to be potentially advantageous overall because of its high heat of combustion. Early attempts to use it in double-base propellants did not yield the expected advantage until it was appreciated that the propellant matrix must be hot enough to ensure effective burning of the metal. This condition prevailed in most of the perchlorate-based propellants, and the use of aluminium to obtain high impulse has become normal.

**Plastic propellant**

63. For reasons outlined in Chapter 2 a plastic propellant was chosen in the British Service as an alternative to cordite at an early stage in the development of rockets; and, following on trials with fuel matrices based on nitrocellulose and then on polystyrene, polyisobutylene (PIB),  $\text{-(CH}_2\text{)}_n\text{-C}=\text{CH}_2\text{-(CH}_2\text{)}_n\text{-}$ , (Chapter 6) was selected as the fuel-binder. PIB is made in the petrochemical industry and can be bought in a number of grades (depending on the average molecular weight of the product) varying from clear viscous liquids (low molecular weight) to rubbery solids (high molecular weight). The grade preferred for plastic propellant has an average molecular weight of about 15 000 and a viscosity of 500 000 poises at 25°C; if it is not immediately available from commerce an adequate substitute can be prepared by blending two nearly adjacent grades. The good low-temperature properties of PIB can be improved if a PIB of a somewhat greater molecular weight is plasticized by addition of ethyl oleate, and such a mixture is now much used.

64. PIB is a hydrocarbon and may thus be regarded as  $(\text{CH}_2)_n$ . Thus, by reference to Chapter 4 it is seen that if a 'balanced' system of PIB and ammonium nitrate should be required it would contain 5.5% PIB. By a similar argument a balanced system of PIB and ammonium perchlorate would contain 9% PIB, but in fact it is found that the maximum (theoretical) specific impulse (Chapter 12) of a PIB/ammonium perchlorate propellant is obtained with just over 10% PIB, because of the lower molecular weight of carbon monoxide and hydrogen as compared with carbon dioxide and water.\* This theoretical maximum is confirmed in practice, but the physical properties of a composition containing only just over 10% PIB are somewhat inadequate, and it is therefore more usual to use about 12%.

65. Ammonium perchlorate (Chapter 5) is received from industry in a finely-crystalline form (about the size of caster sugar). The crystals retain about 0.2% water in their interior and as the salt is required in a finely-divided form, the material, after predrying, is passed at 45°C through a high-speed impact mill to produce the desired size range, before being dried at 80°C for at least 16 hours.

66. A propellant consisting only of 12.5% PIB and 87.5% ammonium perchlorate would be too fast-burning for many purposes, and thus a suitable proportion of ammonium picrate (Chapter 6) is included in some compositions. This material does not require separate drying and is so brittle as not to require separate milling, adequate size-reduction taking place during the processing of the propellant. It is considered a necessary ingredient of compositions having a burning rate less than 0.6 in/s (15.2 mm/s) at 1000 lb/in<sup>2</sup> (6.89 MN/m<sup>2</sup>).

*Manufacture of plastic propellant*

67. In the manufacture of the propellant the appropriate quantity of dry, milled, hot ammonium perchlorate is sifted into an incorporator (preheated to 70°C) through a screen to ensure freedom from adventitious foreign matter. Ammonium picrate, if required, is similarly sifted in. The incorporator is fitted with specially shaped blades having only a small clearance from the pan of the machine, and thus the composition undergoes a great deal of shear-working during its incorporation, conferring on it a high degree of plasticity. The required amount of PIB is weighed out from a steam-heated pan (used to reduce its effective viscosity), premixed with minor ingredients (for example, aluminium powder and burning-rate catalysts, notably titanium dioxide) and added to the incorporator together with a small proportion of a surface-active ('wetting' or 'dispersing') agent. Water at 70°C is passed through the jacket of the incorporator to prevent the generation in the 'dough' of excess temperature (the maximum permitted working temperature is 90°C). Operatives withdraw and start the machine from a remote-control position; at this stage, when the ammonium perchlorate is only partially wetted with the fuel-binder, the mixture is at its most sensitive and presents the greatest risk of ignition — which, if it occurs, is very rapid and violent. In about 10 minutes the mass becomes a coherent dough, and incorporation is complete in a further hour.

68. The product must be deaerated, for which purpose it is fed into a rotating screw which pushes it through a perforated die-plate, from which it emerges into an evacuated chamber in the form of thin cords. The propellant is next loaded into the cylinder of a hydraulic press and extruded directly into a rocket motor, the walls of which have been degreased and precoated with an adhesive to bond the propellant; a former of desired shape is mounted axially on the front of the press, extending into the motor to give an axially symmetrical central burning surface to the propellant charge. The former is extracted from the motor by a jack. (In recent times a number of engineering improvements have been made to the filling process, but the foregoing description is adequate for present purposes.)

\*The relationship between the specific impulse ( $I_{sp}$ ), the rocket-motor temperature ( $T_r$ ) and the mean molecular weight of the products of combustion ( $\bar{M}$ ) is given by the relationship:

$$I_{sp} \propto (T_r/\bar{M})^{1/2} \quad \text{----- (5)}$$

Table 2  
Representative propellant compositions

	RD 2427	RD 2425	RD 2421	RD 2423
Amm. Perchlor	42	57	64	84.5
Amm. Pic.	38	30	10	
Aluminium	5	—	15	
Plast'd. PIB	12	11	10	12.5
TiO <sub>2</sub>	—	1	—	
CuCrO <sub>4</sub>	—	—	—	2
Oxamide	2	—	—	
Surfactant	1	1	1	1
*R <sub>b</sub> (in/s)	0.15	0.40	0.50	1.5

\*R<sub>b</sub> in Table 2 is the rate of burning at 1000 lb/in<sup>2</sup> (6.89 MN/m<sup>2</sup>) pressure

#### Representative plastic propellant compositions

69. Compositions have been developed which will burn at any rate in the range 0.10 in/s to 1.5 in/s (2.5 mm/s to 38.1 mm/s) at 1000 lb/in<sup>2</sup> (6.89 MN/m<sup>2</sup>). A few representative compositions which have been used in guided weapons or in space applications are given in Table 2

#### Limitations of plastic propellants

70. Plastic propellants have proved adequate for many Service requirements, but there is a limit to the size, and in particular the diameter, of motors for which they are suitable; clearly, a plastic mass can flow under its own weight at some point, which will occur sooner, in any given charge diameter, as the temperature rises and the viscosity of the binding agent falls. However, motors of some 20-inch (568 mm) diameter containing a ton of plastic propellant have met reasonable Service requirements, and motors of 36-inch (914 mm) diameter have been made (for 'space' projects) and fired successfully at ambient temperature. There has also recently been a requirement for this propellant in non-military systems, for example in coastguard line-throwing and signal rockets, in meteorological rockets, and in rockets to propel high-speed test vehicles on special runways.

#### Rubbery composite propellants

##### Some advantages and disadvantages

71. Obviously a rubbery fuel matrix will enable a composite propellant to withstand the physical stresses imposed by high climatic temperatures, as well as the gravitational and 'set back' stresses at any temperature, better than will a viscous liquid matrix. But a great deal of specially orientated research has been required in the USA before, in recent years, it has been possible to claim for certain types of synthetic rubber-based composite propellants the ability to meet the lower range of Service temperature requirements; investigation of these propellant systems continues in the USA and in this country.

72. The incorporation of oxidant, and other solid ingredients, into a rubbery matrix to form a composite propellant would be both difficult and hazardous. For this reason the choice of a synthetic rubber for use as a propellant fuel-binder is limited to those rubbers which can be made from a liquid mixture simply by heating at a moderate temperature (not above 80°C) for a moderate period of time (preferably not more than a few days). The solid ingredients can then readily be mixed into the liquid rubber precursor to form a pourable slurry which can be cast into a mould (usually the rocket-motor case) and heated to bring about conversion to the required rubbery state.

##### General principles

73. A typical rubbery propellant fuel-binder which has been extensively investigated by the Explosives Research and Development Establishment is the polyurethane rubber derived from a liquid polyester by reaction with a diisocyanate. A discussion of this system will illustrate some of the general principles involved in the subject of rubbery composite propellant binders.

74. Suppose that a dihydric alcohol of type HO-A-OH is used to esterify a dibasic acid of type HOOC-B-COOH. Polymeric esters may be formed of types:



These may be viscous liquids, visco-elastic liquids, or rubbery or resinous solids, according to their structure and molecular weight. For the precursor of a rubbery binder, a hydroxy-terminated polyester of molecular weight about 2000 is chosen; this is obtained by using an excess of the dihydric alcohol in the esterification reaction. It is a viscous liquid, having a viscosity of about 80 poises at 25°C, and is sufficiently fluid for the mixing of the initial propellant slurry to be done without difficulty. To convert this polyester to a 'rubber' it is reacted with a diisocyanate of type O:C:N.X.N:C:O, when each -NCO group becomes a carbamate (or urethane) group (see equation 9).



75. Thus the molecular chains of the polyester are linked together to form the very long chains of a polyurethane which will be a 'rubber' but will not be perfectly elastic (that is, it will not completely recover its shape after straining) since the individual molecular chains are free to move relative to one another. To obtain the desirable property of elasticity it is necessary to link substantially all the molecular chains together in such a manner as to form a network, or three-dimensional cross-linked structure, extending throughout the material. Such a network cannot be obtained from reactants which are all bifunctional (as is the case with the foregoing hydroxy-terminated polyester and the diisocyanate) but it can be brought about by using in the preparation of the polyester a small proportion of a reactant having a functionality greater than two. A convenient such reactant is pentaerythritol, C(CH<sub>2</sub>OH)<sub>4</sub>, a small proportion of which is substituted for an equivalent quantity of the dihydric alcohol when making the polyester. The resulting polyester contains a proportion of molecules having a functionality of four, for example:



76. During the subsequent reaction with the diisocyanate these tetrafunctional polyester molecules will act as chain-branching or cross-linking centres, so that eventually almost all the molecules will be joined together in a network structure. (Of course there must not be too many cross-links or the product may be a brittle solid.) The cross-linking reaction is fairly slow, but is accelerated by heat (see para. 72).

77. In practice, there is a wide choice of di-alcohols and dibasic acids commercially available, but only two di-isocyanates are normally marketed (those in which X is hexamethylene, -(CH<sub>2</sub>)<sub>6</sub>-, or tolylene, -CH<sub>2</sub>C<sub>6</sub>H<sub>4</sub>-, the latter being the more usual).

#### *Manufacture of rubbery composite propellants*

78. In the production of the propellant the first step is to make the desired polyester and to free it from all trace of water, which would react with (and so consume a part of) the diisocyanate.

79. The required weight of polyester is then measured into a jacketed vessel fitted with stirring gear and bottom run-off and capable of being connected to a vacuum line. The appropriate amount of ammonium perchlorate is then stirred in, together with burning-rate catalyst, followed by aluminium powder. The loading-hole in the lid is then closed and the vessel put under vacuum to remove air bubbles from the mix, which is warmed at this stage to reduce the viscosity. The mix is then cooled and the calculated quantity of (liquid) isocyanate is admitted from a burette. The complete mix is now 'cast' into the prepared rocket-motor case, which is in an evacuated vessel connected to the bottom run-off and has been fitted with a former of the required shape for the burning surface. (The outer evacuated vessel is required because the motor case alone is not necessarily strong enough to withstand evacuation.) When casting is complete the motor is removed to a 'curing' stove, where the rubbery propellant charge is formed. On removal from the stove the motor is allowed to cool before the former, which was coated with 'Teflon' to prevent adhesion, is extracted.

80. Polyurethane propellants had to be stored under dry conditions, to avoid degradation; they would meet Service temperature requirements down to -30°C in some motors. Like CDB propellants, they could readily have complex, or even off-centre, burning surfaces.

*Miscellaneous rubbery composite propellants*

81. In America, early composite propellants were based on plasticized polyvinyl chloride (the 'Arcite' series of propellants), on 'Thiokol' rubbers (having sulphur linkages in the polymer molecule) and on polyurethane rubbers based on polyesters. However, such rubbers have now largely been replaced by rubbers derived from butadiene,  $\text{CH}_2 = \text{CH} \cdot \text{CH} = \text{CH}_2$ , which are almost completely hydrocarbon and thus are better fuels. The better types of polybutadiene rubber give a propellant of higher specific impulse not only because they are more nearly hydrocarbon in character but also because they can tolerate a higher level of solids loading, enabling compositions to be made with 88 to 89% of oxidant (cf the 80 to 82% oxidant usual in a polyester polyurethane propellant). In addition they have physical properties superior to those of most other rubbers, especially at low temperatures, and they enable a somewhat wider range of burning rates to be obtained. Unfortunately most of the polybutadiene-based propellants are somewhat susceptible to deterioration of physical properties if stored under hot humid conditions, although in recent years some improvement in this respect has been obtained.

82. Perhaps the best polybutadiene propellant binder so far developed is one based on a bifunctional carboxy-terminated (liquid) polybutadiene of average molecular weight about 4000.



This can be converted to a solid rubbery polymer by reaction with either aziridine (equation 12) or an epoxide (equation 13), or a mixture of both.

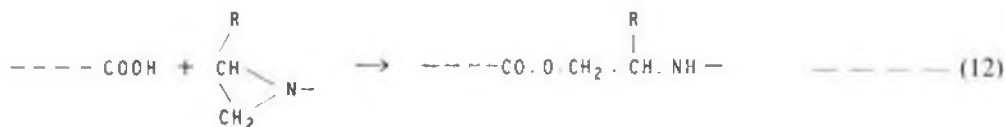

The desired degree of cross-linking (see equation 12 and 13) can be obtained by using a trifunctional aziridine or epoxide, or a mixture of bi- and tri-functional curing agents, or by using a bifunctional curing agent with a liquid polybutadiene having, on average, rather more than two carboxyl groups per molecule.

83. Propellants based on such rubbers and containing 84% of solids will meet Service temperature requirements as low as  $-55^\circ\text{C}$ .

**Composite-modified cast-double-base propellant, CMCDB**

84. In the light of what has been written about the matrices of composite propellants employing the powerful oxidant ammonium perchlorate and about the nature of cast-double-base propellant, it will be appreciated that it soon appeared to the proponents of CDB compositions that it would be desirable to incorporate in such compositions a proportion of ammonium perchlorate which in effect would be embedded in a CDB matrix. This was most readily achieved by incorporating the perchlorate into the casting powder, and then casting in the usual way.

85. However, there were two matters to which special attention had to be paid and these were:
- (1) in presence of ammonium perchlorate, the commonly used stabilizer carbamite was completely unsuccessful while diphenylamine and 2-nitrodiphenylamine were also inadequate. A search had therefore to be made for a new substitute which was found in resorcinol
  - (2) there is a risk of detonation if nitrocellulose powders are ignited in depths of more than 18 to 24 inches (457 to 610 mm). This depth is reduced as NG is added to the composition of the powders. For powders containing ammonium perchlorate it was found to be no more than 5 to 6 inches (147 to 152 mm) depth. Thus special measures had to be taken for the storage and transport of the casting powders for CMCDB.

## Liquid propellants

### General and historic

86. Liquid propellants are usually classified as 'monopropellants', self-sustaining individual liquids, or 'bipropellants', systems of two separately-stored liquids (fuel and oxidant) which can be made to burn steadily together when suitably mixed in a combustion chamber. Bipropellant systems can have values of specific impulse well in excess of the maximum of 245 to 250 practically attainable with solid propellants. They are primarily of interest in rocket propulsion, and their efficiency depends as much on the engineering design of the injection system and combustion chamber as on the propellant itself, but those considerations are not relevant here. Difficulties have hitherto stood in the way of the use of liquid propellants in guns and have not yet been resolved.

87. The first notorious use of liquid propellants (of both classes) was in the German V2 rocket, which employed alcohol and liquid oxygen in its main propulsion system and hydrogen peroxide to provide hot gases to power the turbine which drove the pumps which fed the bipropellant liquids to the combustion chamber.

88. The success of the Germans with the V2 and with liquid propelled aircraft rockets led to much interest in liquid propellants after the 1939-45 War, but in the UK this interest was modified as policy developed in the direction of anti-aircraft defensive systems rather than long-range offensive systems; in defensive systems immediate readiness for use is important and this is more readily achieved with solid propellant systems than with liquids. However, the Admiralty did develop the use of hydrogen peroxide for submarine propulsion and the Royal Air Force employed iso-propyl nitrate as a source of hot gases to power engine-starters, while for a period the Army employed the US 'Corporal' rocket, which used the bipropellant system of fuel and oxidant in which the oxidant was 'red fuming' nitric acid. 'Red fuming' nitric acid, RFNA, is a mixture of nitric acid and nitrogen tetroxide, the corrosive properties of which on metals were 'inhibited' by the addition of a small proportion of hydrofluoric acid. 'Corporal' fuel was a mixture of equal parts of aniline and furfuryl alcohol with 7% of hydrazine, which was self-igniting with the RFNA.

### High Test Peroxide, HTP

89. Concentrated hydrogen peroxide (see also Chapter 5) is readily decomposed, not only by chemical catalysts (such as the oxides of polyvalent metals) but by heat and by some surfaces (for example, finely divided atmospheric dust). Thus any vessels in which it is to be stored must be highly cleaned and protected against the ingress of atmospheric and other impurities; however, they cannot be totally closed since even changes of climatic temperature may promote some decomposition (with consequent rise in pressure) according to the equation:



The HTP, itself, is 'stabilized' by the addition of sodium stannate, the colloidal stannic hydroxide associated with which adsorbs adventitious impurities. Aluminium is the preferred material of construction for HTP vessels and pipe-lines, with silicon-aluminium alloy for parts such as valves which must be machined. Welds must be thoroughly hammered to remove flux, and the finished system should be filled with concentrated nitric acid before use to form a protective coating of alumina on its surfaces, after which it must be very thoroughly washed with distilled water.

90. When HTP is to be used as a monopropellant the decomposition reaction is induced by bringing it into intimate contact with catalysts in a suitably designed chamber. If the catalyst bed were too concentrated it would get over-heated and, perhaps, fuse together. It was the practice therefore to use as catalyst a bed of porous ceramic 'stones' which had been impregnated with suitable oxides of polyvalent metals, for example, copper, chromium, nickel, etc; but more recently a 'pack' of silver gauze has been used. The heat of reaction results in the production of a mixture of superheated steam and oxygen which can be used either to power a machine, such as a turbine, or in a venturi to give 'rocket propulsion'.

### Isopropyl Nitrate, IPN

91. Isopropyl nitrate (see also Chapter 6) is a stable liquid, non-explosive within the provisions of the Explosives Acts but rather easily capable of ignition by 'dieseling' with air, for which reason compressed air should not be used to expel it from vessels. It can be stored in mild steel vessels.

92. If sprayed onto a pre-heated bed of chromic oxide IPN is decomposed catalytically, with evolution of heat, to yield hot gases consisting mainly of carbon monoxide and dioxide, nitrogen and steam; there may also be some hydrogen and free carbon. In the engine-starter system pre-pressurized IPN is so

decomposed on an electrically preheated catalyst and the hot gases are used to drive the turbine of the starter. It is difficult to filter the gases, which carry with them particles of catalyst which cause some erosion of the turbine blades.

### Hybrid propellants

93. A brief note on this subject is added less because hybrid propellants are of present Service interest than because they will probably be mentioned in any general discussion of rocket propellants.

94. The concept arose from the fact that many of the earlier, non-perchlorate, propellants burnt to give rise to considerable proportions of carbon monoxide and carbon. It seemed that if an oxidant could be added to the combustion products or, even better, introduced to the burning surface more efficient combustion should result. An early idea was to pass the gases from an ammonium nitrate-rich composition over the burning surface of a cordite charge. This was succeeded by the notion of spraying into the motor a liquid oxidant, and this in turn led to the idea of using hypergolic (self igniting) systems of liquid oxidant and solid fuel, for example, chlorine trifluoride and wax/light metal mixtures. Many variants on the theme have been propounded during the last two decades. Among the advantages claimed by their proponents are:

- (1) capability of thrust control and of 'on-off' functioning by control of the rate of injection of the oxidant
- (2) capability of employing very energetic oxidant-fuel combinations which are under normal conditions incompatible
- (3) reduced hazard under fragment attack because oxidant and fuel are separated.

Disadvantages are:

- (1) greater complexity of the weapon system
- (2) non-uniform consumption (that is, erosion) of the fuel charge with resulting incomplete utilization of the charge
- (3) low performance when operating outside conditions of stoichiometric combustion.

## CHAPTER 9

**Primary Explosives, Sensitizers, and Cap, Igniter and  
Detonator Compositions**

**CONTENTS**

		<i>Para</i>
<b>Primary explosives</b>		
<b>Primary and secondary explosives</b> .....		1
<b>Mercury fulminate</b> .....		6
<b>Lead and silver azides</b> .....		15
<i>Types of lead azide</i> .....		16
<i>Manufacturing equipment</i> .....		17
<i>Service lead azide</i> .....		19
<i>Service lead azide properties</i> .....		22
<i>Dextrinated lead azide, RD 1352</i> .....		26
<i>Lead azide, RD 1343</i> .....		30
<i>Silver azide, RD 1336</i> .....		32
<b>Lead and barium styphnates</b> .....		34
<i>Lead styphnate, RD 1303</i> .....		34
<i>Basic lead styphnates</i> .....		39
<i>Barium styphnate</i> .....		42
<b>Lead dinitroresorcinates</b> .....		43
<b>Lead trinitrochloroglucinate</b> .....		46
<b>Lead azotetrazole</b> .....		47
<b>Sensitizers</b>		
<b>Purpose of sensitizers</b> .....		51
<b>Tetrazene</b> .....		52
<i>Structure of tetrazene</i> .....		52
<i>Manufacture and properties of tetrazene</i> .....		54
<b>Cap, Igniter and Detonator Compositions</b>		
<b>Compositions ignited mechanically</b> .....		59
<i>Cap compositions</i> .....		60
<i>Compositions with mercury fulminate</i> .....		62
<i>Compositions without mercury fulminate</i> .....		65
<i>Detonator fillings</i> .....		68
<b>Compositions ignited electrically</b> .....		70
<b>RD series compositions</b> .....		76
<b>Illustrations</b>		
<i>Fig</i>		<i>Page</i>
1 Lead styphnate .....		7
2 Tribasic lead styphnate .....		7
3 Lead trinitrochloroglucinate .....		8
4 Tetrazole and azotetrazole .....		9
5 Monobasic lead azotetrazols .....		9
6 Suggested reaction to produce tetrazene .....		10
7 Alternative suggested tetrazene end product .....		10

**Tables**

	<i>Page</i>
1 Cap compositions with mercury fulminate .....	12
2 Cap compositions (pre World War 2) without mercury fulminate .....	12
3 Lead styphnate compositions RD 1653 and RD 1654 .....	14
4 A summary of some RD 1300 series compositions adopted for service in the United Kingdom and abroad .....	14

## CHAPTER 9

## Primary Explosives, Sensitizers, and Cap, Igniter and Detonator Compositions

### Primary explosives

#### Primary and secondary explosives

1. 'Primary explosives' is the expression now more frequently used to describe those explosives formerly known in this country as 'initiators'; the change has become desirable partly because 'primary explosives' is a more distinctive description of the substances concerned and partly because in United States practice 'initiators' are devices employed to initiate an explosive system.
2. The assessment of the boundary between 'primary' and 'secondary' (or 'high') explosives is a matter on which there could be considerable argument, depending on the nature and scope of the criteria applied; but it is considered convenient, in the present state of knowledge, to take mechanical sensitiveness as the principal criteria, and explosives showing sensitiveness greater than that of tetryl or, perhaps, PETN are considered to be in the primary explosive class. But such broad classification should not be taken too literally; much depends on the design and use of the munition store in which the explosive is to be employed.
3. Most primary explosives show a relatively low Figure of Insensitiveness (F of I) as measured by the Rotter Impact Test (Chapter 14). Typically the F of I of primary explosives is less than 50, whereas that for such a typical 'high' explosive as RDX is 80, and other high explosives have higher values.\*
4. Besides specifying a low F of I, Service requirements may call for sensitiveness to friction or heat in a primary explosive, and will certainly call for adequate chemical stability and the capacity to withstand (in the form in which the primary explosives are present in the finished munition store) the Service conditions of storage and handling. To these considerations must be added the requirements of safety and reliability in manufacture and in use in the Filling Factories.
5. Finally, after all the other requirements are met the choice of a primary explosive for a Service application may be influenced by its electrical properties.

#### Mercury fulminate

6. The mercuric salt of fulminic acid,  $Hg(ONC)_2$ , was discovered by Kunckel in the 18th century, but was rediscovered by Howard at the turn of the century, when he characterized its explosive properties. (Fulminic acid is known only in solution and has never been separated in the pure state, but its structure is believed to be that of the oxime of carbon monoxide, that is C:N.OH.) The mercuric salt is strongly endothermic (heat of formation equals  $-65.7$  kcal/g mol) and under suitable confinement it will detonate if subjected to impact, friction or heat (see equation 1).



If laid as a train in the open it will burn without explosion.

7. It is manufactured by what is, in effect, a large-scale laboratory process, using glassware. One part by weight of pure mercury is dissolved in 11 parts of 57.5% nitric acid, to yield a solution of mercuric nitrate (in excess nitric acid) which is poured into 10 parts of 90% ethyl alcohol contained in a large flask. A brisk reaction commences, with evolution of fumes, at first white, then brown, then again white, and the temperature rises from 20°C to over 80°C as mercuric fulminate is precipitated in fine crystals of about 99% purity. After cooling, the supernatant liquid is decanted and the dense crystals are washed free of acid by using several lots of water with decantation. The product is then filtered on muslin and dried in small quantities, as required, at a temperature of about 40°C. It is usually grey or brownish, and can safely be stored in the wet state. It has a density of 4.45 g/ml and a bulk density of 1.7 g/ml.
8. When being pressed into detonators its loaded density is between 3.5 and 4 g/ml. If it is compressed further it becomes less sensitive to all forms of mechanical stimulus, and less receptive to flash. When thus rendered inert it is said to be 'dead pressed'.

\*It is the usual Service practice to manufacture the primary explosives in the Filling Factories in order to avoid the possible risks attendant on the use of 'outside' transport.

9. By varying the proportions of the reactants during the manufacture, mercury fulminate can be produced having different physical forms and bulk densities, which characteristics may be coupled with increased chemical stability, particularly when stored under adverse conditions. However, in spite of several attempts, satisfactory loading characteristics have not been achieved, and such materials have not been introduced into Service.

10. It is not hygroscopic, but in presence of water it tends to react with metals, with which it forms fulminates whilst liberating mercury. For this reason it cannot be used in aluminium-sheath detonators, and is usually protected from access of moisture in other detonators by applying a film of varnish to its free surface after pressing.

11. It is soluble in aqueous-alcoholic ammonia and in aqueous solutions of alkali, iodides and cyanides and of sodium thiosulphate (in the last instance with decomposition). The solubility of mercury fulminate in sodium thiosulphate allows analysis of the compound to be done or enables it to be destroyed in quantity. It is highly toxic.

12. It ignites with detonation at about 170°C after heating at 5°C/min, and it may detonate on prolonged heating at 100°C. It has an F of I of 10 and is very sensitive to friction. Its velocity of detonation is low (3000 to 4000 m/sec) but is rapidly attained, and consequently its effect is very local.

13. Although it has had a long life in military use, mercury fulminate is, in fact, an unsatisfactory Service explosive because it deteriorates rapidly when subjected to heat. Under dry heat at 175°F (80°C) it becomes completely insensitive (with decomposition) after 9 days; and under the hot-wet conditions of tropical storage it becomes insensitive after 3 to 4 months at 120°F (50°C). However, it has been used in detonators, alone or in admixture with 10% to 20% potassium chlorate, and as an ingredient of cap composition since before the First World War. Detonators employing it are still made in various forms, mainly commercial, and may have percussion or igniferous initiation (the latter being employed where the detonator follows an igniferous device). But its extreme sensitiveness imposes limitations on the quantity of fulminate which can safely be used in fuze detonators, which may be subjected to high accelerations in guns.

14. Mercury fulminate and mixtures based upon it are now being rapidly superseded in Service usage, and the amount of mercury fulminate now manufactured is extremely small.

**Lead and silver azides**

15. The explosive properties of the azides of lead, silver and mercury were first studied about 1890 by Curtius, who had been the earliest investigator of hydrazoic acid. He had believed hydrazoic acid to have the structure:



but which is now known, as a result of X-ray and other studies, to have the (canonical) structure



*Types of lead azide*

16. Lead azide, Pb(N<sub>3</sub>)<sub>2</sub>, is known in four polymorphic forms; alpha, beta, gamma and delta. The alpha form is that which usually occurs, although the presence of the beta form has been observed in the early stages of preparation of lead azide under conditions of poor mixing of the reactants (so that there is slow diffusion of reactants). It was at one time thought that the beta form was very sensitive — and even unstable — but it is now known that it is stable and that its sensitivity to impact and friction is not markedly different from that of the alpha form. Little is known of the properties of the recently discovered delta form, but the sensitiveness of the gamma form to impact is appreciably greater than that of the alpha form, although its sensitiveness to friction is lower. Admixture of Service (alpha) lead azide with 10% of either beta or gamma forms causes an increase in sensitiveness to both impact and friction.

*Manufacturing equipment*

17. In the manufacture of lead azide it is necessary that the equipment shall be so designed as to be capable of isolation from the operative, who is protected by a reinforced concrete wall fitted with either an arrangement of mirrors or small 'armourplate' glass windows through which the plant can be observed; this is necessary because lead azide is sensitive whether wet or dry and because, under some

conditions, it can detonate spontaneously. Accordingly, a standard equipment has been designed for use in the Filling Factories for the manufacture of Service lead azides and of any other primary explosives capable of being made by a double-decomposition reaction; it has been adopted in a number of other countries which have recognized its value in the production of materials of reproducible characteristics.

18. The principal item of the plant is a jacketed stainless-steel tilting pan, made to precise measurements and to a high standard of finish, and fitted with a stirrer also of precise dimensions and high finish. The jacket of the pan can be fed, through flexible connections, with either cold or hot water or steam as required. The speed of the stirrer affects the crystal-size of the product, and may be controlled either by a variable speed gear or by fitting to the drive motor an electronic controller which does not reduce the torque; a flexible drive between the motor (on the 'safe side' of the wall) and the stirrer allows the latter to tilt with the pan when necessary. The pan is normally tilted to a precise small angle to avoid the formation of a 'dead' volume below the stirrer.

#### *'Service' lead azide*

19. Filtered stock solutions of sodium azide (buffered by sodium carbonate to the correct pH) and of lead acetate are stored in stainless-steel tanks, whence the appropriate amounts are drawn into measuring vessels for each batch. A measured volume of water is placed in the pan, and gutta-percha tubes connected to the calibrated run-off jets of the two measuring vessels are set in the pan so as to give opposed flows just below the surface of the water. With the stirrer running and after a base solution of sodium carbonate has been added, the azide and acetate solutions are run in during a period of about an hour, the temperature of the mix being held below 25°C. Lead azide is precipitated in the form of free-flowing fine white crystals, which are washed by decantation with water several times in the pan, followed by a wash with alcohol. Finally the pan is tilted to enable the crystals to be washed onto a filter, which consists of a muslin bag in a gutter-percha filter-pot having a flat perforated base.

20. This pot, suitably covered, can then be removed to the drying room, where it is placed in a recessed hole in a suction box and fitted with a gutta-percha lid having a tubulure connected to a metered supply of clean dry air free from carbon dioxide. When the appropriate amount of air to dry the lead azide has been passed through it the pot is removed to the screening room, where (by remote control devices) it is tilted over a stainless-steel or silk vibrating screen through which almost all of the lead azide passes to a 6-way divider, so that 6 gutta-percha pots each receive loads of about 4 oz (113.4 g) for use in the filling shops. When these pots have been removed the screen can be tilted by remote control to empty out the small amount of coarse crystals remaining.

21. The liquors from the process, together with any waste lead azide, are treated with weak acetic acid and sodium nitrate; the nitrous acid arising from the latter reacts with hydrazoic acid in accordance with equation 4.



#### *'Service' lead azide properties*

22. The Service lead azide made by the preceding process is upwards of 97% pure (the remainder is mainly a basic lead carbonate employed as the nucleating agent) and is used, alone or with other compositions, in many detonators. It has a density of about 4.8 g/ml and a bulk density of about 1.9 g/ml. Its ignition temperature is about 330°C when heated at the rate of 5°C/min, and on explosion it decomposes (equation 5):



It has an F of I of about 15 to 20, but is more sensitive to friction than is mercury fulminate, though much less sensitive to pricking. Any pure or nearly pure crystalline lead azide becomes much more sensitive to friction when contaminated with grit (or with such other crystalline matter as RDX and tetryl) and is then hazardous to fill. The velocity of detonation of Service lead azide is 4500 m/sec at a pressed density of 3.8 g/ml.

23. Unlike mercury fulminate, Service lead azide does not readily become 'dead-pressed', does not deteriorate rapidly during hot dry storage and can be used in proximity to aluminium (para. 10). Lead azide is incompatible with copper or copper alloys at high relative humidities because it is slowly hydrolyzed by moisture, with evolution of hydrazoic acid which forms an extremely sensitive cuprous azide, which is then oxidized by air to an only slightly less sensitive cupric azide. This, in turn, is converted to basic cupric azide, which has about the same sensitiveness as lead azide. This 'copper azides' problem arises only at high levels of humidity (it was not observed in trials at 75% RH) but such conditions may arise in a sealed store in which some ingredient of the filling is not absolutely dry. It is therefore necessary to design stores having azide-filled detonators in such a way as to avoid the risk; this trouble is worthwhile, apart from safety considerations, because lead azide is a more efficient primary explosive on a weight basis than is mercury fulminate. The tinning of copper components has been found to afford good protection against attack by hydrazoic acid.

24. Lead azide has been used in British Services since about 1925, when it was introduced as the main filling of 'composite' detonators, which had a topping of a mercury fulminate mixture to achieve the required degree of sensitiveness to functioning by needle stab or from flash, to both of which lead azide is less sensitive than is the fulminate mixture. Service lead azide continues to be the main filling of composite Service detonators, and because of its high detonation efficiency (due to its purity) it is used in quite small detonators (for example, 1.5 grain\* detonators) in combination with a suitable priming composition and an HE, usually CE.

25. It was stated in para. 17 that lead azide is capable of spontaneous detonation. So far as is known, this phenomenon occurs in practice only during the precipitation stage of manufacture. Over a lengthy period about 1 lot in 6000 of Service lead azide was lost at this stage, while the records show that half as many incidents occur at the sieving stage, and fifteen times as many incidents occur during filling (incidents which are generally attributed to mechanical or electrostatic causes). What is known is that spontaneous detonation at the precipitation stage does not occur if the manufacture is conducted in the presence of additions of hydrophilic colloids, for example, dextrin, methyl cellulose or carboxy-methyl cellulose.

*Dextrinated lead azide, RD 1352*

26. In United States' military practice lead azide was adopted about 1930 as a primary explosive, but in the commercially-made 'dextrinated' form. Because certain stores of US design are made in United Kingdom Filling Factories for Service use, dextrinated lead azide has also been made in those Factories, under the designation RD 1352.

27. Dextrinated lead azide is in rounded aggregates having no observable crystal faces. It is white to buff in colour and contains only about 93% lead azide (the US specification permits as little as 91.5%) together with 4% basic lead azide and 3% dextrin and other impurities. Because of its lower purity it is a less efficient initiatory explosive than is Service lead azide.

28. Dextrinated lead azide is made in the United States by adding to a stirred solution of lead nitrate (heated to 71°C and containing dextrin to the extent of 5% of the weight of the lead salt) a solution of sodium azide containing 2.5% of caustic soda (calculated on the azide). In other respects the process resembles that for Service lead azide. The nodular product has an apparent bulk density of 1.5 g/ml and an absolute crystal density of 4.68 g/ml to 4.7 g/ml. Under equal pressing loads it gives a less dense product (for example, 3.28 g/ml at 20 000 lb/in<sup>2</sup>, 138 MN/m<sup>2</sup>) than does Service lead azide. It is somewhat hygroscopic; when exposed to 90% RH at 30°C it gains 0.8% in weight.

29. The dextrinated lead azide, RD 1352, made in this country for Service use is, compared with the American product, less vulnerable to changes in the source of supply of dextrin and has more consistent chemical and physical characteristics, including higher lead azide content and higher bulk density. These benefits result from the use during the precipitation stage of an anionic dispersing agent in addition to the dextrin.

*Lead azide, RD 1343*

30. Lead azide, RD 1343, is a form of lead azide of high azide content and of free-flowing granular nature (having a bulk density of 1.6 g/ml and low hygroscopicity) which is prepared by carrying out the precipitation in presence of a proportion of sodium carboxymethyl-cellulose. Apart from increased safety in manufacture, it has advantages in the detonator filling processes and is now permissible for larger detonators; its slightly lower pressed density renders it unsuitable for the smaller British detonators in which, however, Service azide is effective. RD 1343, or the related RD 1333, is used in the smaller American Service detonators.

31. Lead azide can be co-precipitated with other substances (as inclusions and coatings), in presence of hydrophilic colloids, to give products for special purposes.

*Silver azide, RD 1336*

32. Silver azide,  $A_2N_6$ , has received a good deal of attention because it is not subject to hydrolysis by moisture and is as effective a primary explosive as lead azide if made in appropriate crystal form. Only one crystalline form is known at ordinary temperatures; a beta form exists at high temperature. Silver azide is made by the same general technique as Service lead azide, starting from silver nitrate and sodium azide, but without carbonate nucleation; the precipitation is effected in a dilute ammoniacal medium in order to give rise to the necessary physical form of the product. It is incompatible with sulphur compounds (for example, antimony sulphide) and with tetrazene, and with some metals (for example, copper) when the possibility of exchange of metal radicals may result in the formation of a sensitive composition.

\* 1 grain = 64.798 mg

33. Recently, silver azide (designated as 'W composition') has been recommended for use in composite detonators (of the flash-receptive type) to replace lead azide when the environmental conditions may cause deterioration of the lead azide.

#### Lead and barium styphnates

##### *Lead styphnate, RD 1303*

34. Lead styphnate is the normal lead salt of styphnic acid (see Chapter 6) having one molecule of water of crystallization (see Fig. 1).

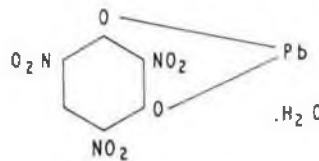

Fig. 1 Lead styphnate

35. It is made by the reaction of magnesium styphnate (prepared by stirring together styphnic acid and magnesium carbonate in water at 75°C) and lead acetate (also in aqueous solution at 75°C); an adsorption complex, basic in lead content, is formed and is subsequently converted to the normal salt by acidification with dilute nitric acid. The mixture is cooled to 35°C, and the lead styphnate is allowed to settle before being washed three times with water and once with alcohol, followed by drying in carbon-dioxide-free air before sieving on an earthed stainless-steel screen.

36. This form of lead styphnate occurs as small crystals, yellow to light brown in colour and of density 3.09 g/ml. Its ignition temperature is about 250°C when heated at the rate of 5°C/min. Its F of I is 25: it is less sensitive to friction than is mercury fulminate, but it readily electrifies and presents a considerable 'static' risk, necessitating careful precautions during handling. RD 1303 has a lesser tendency to propagate ignition when in loose crystalline form than have other forms of lead styphnate, and it has a good record of freedom from accidental ignitions. Its velocity of detonation at a bulk density of 2.6 g/ml is 4900 m/sec.

37. It can be destroyed by treating with 20% nitric acid, filtering off the styphnic acid and adding sodium sulphate to the filtrate to precipitate the lead.

38. It is used in considerable quantity as an ingredient of cap and detonator compositions, for many of which it is not necessary that the styphnate shall have been prepared from the purest styphnic acid. For this reason RD 1367 (a normal lead styphnate prepared from unpurified styphnic acid) has lately been introduced as an acceptable cap composition of much reduced cost. RD 1360 is a form of lead styphnate coprecipitated with finely divided boron; it has a markedly reduced sensitiveness to electrostatic spark.

##### *Basic lead styphnates*

39. Because of its water of crystallization, lead styphnate is not suitable for use in stores which may be subjected to high temperatures (in excess of about 130°C) in use. For this purpose, and because of other possible advantages such as more acceptable compatibility and physical form, mono-basic lead styphnate has been found of use. It exists in three polymorphic forms. Two compositions based upon the beta form (obtained by control of the conditions of precipitation) are known in Service respectively as RD 1349, which is employed in high temperature fuzeheads, and RD 1346, which is a free-flowing granular material for dry loading. The ignition temperature of monobasic lead styphnate is 248°C-250°C. It suffers no loss of weight on heating for 2 hours at 170°C at a pressure of 10 mmHg.

40. The high brisance of normal lead styphnate renders it unsuitable for some applications, and tribasic lead styphnate (see Fig. 2) has been found to be an excellent priming composition, but of reduced violence.

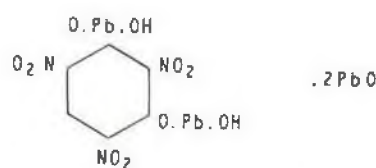

Fig. 2 Tribasic lead styphnate

It is prepared by precipitation from solutions at appropriately high pH. It loses only 0.14% by weight on heating at 170°C for 2 hours at a pressure of 10 mmHg; its ignition temperature is 245°C.

41. If the preparation of tribasic lead styphnate is done with finely divided boron in suspension in the disodium styphnate base solution, the crystalline product contains occlusions of boron. The product containing 5% boron is known as RD 1361, and that containing 12% boron as RD 1361B. Both are more igniferous than (but as thermally stable as) tribasic lead styphnate. They are used in fuzeheads and igniters.

#### *Barium styphnate*

42. In the search for materials having properties to meet some of the modern requirements it was natural to examine heavy metal salts of styphnic acid other than those of lead. Normal barium styphnate, prepared from barium acetate, crystallizes with one molecule of water. It has an F of I of 36. Under the designation RD 1320 it is used in delays, and a different crystal form is used under the designation RD 1340 as an ingredient in priming and igniting compositions. It readily co-precipitates with boron.

#### **Lead dinitroresorcinates**

43. The lead salt of 4:6-dinitroresorcinol was first used in the British Service, under the designation 'Service LDNR', to replace gun-cotton dust in a torpedo bridge-wire detonator. It was replaced by RD 1308, in which the LDNR contained carboxymethyl cellulose as a granulating agent; this is still used in some special igniters, but is becoming obsolescent. A further development is a pure basic 4:6-LDNR, known as RD 1353; this is composed of 3 molecules of normal lead salt in association with 2 molecules of lead hydroxide. It is a more free-flowing material, suitable for dry loading, and is used for delays and igniters. RD 1358 is an acid 4:6-LDNR used in fuzeheads.

44. RD 1308 was used as a delay composition in the early production of impact fuzes for 30 mm aircraft ammunition in the Second World War, but was found to give too long a delay, so that the shell could pass through an enemy craft before exploding. It was found that the normal lead salt of 2:4-dinitroresorcinol, then known as RD 1305, overcame this problem. Subsequently, an improved method of manufacture gave a better product, designated RD 1337 (also known as 'R' Composition), which replaced RD 1305. RD 1337 is still used for short delays in priming compositions and is used alone as the priming explosive for modern flash-receptive composite detonators, in which it is followed by lead azide or silver azide layers. It is also used in admixture with barium nitrate and tetrazene in 'L' mixture (RD 1651), a stab-sensitive priming composition (see para. 67).

45. RD 1337 withstands modern temperature requirements because it has no water of crystallization.

#### **Lead trinitrophenolglucinate**

46. It was remarked in para. 34 that lead styphnate crystallizes with a molecule of water (3.85% by weight of the whole molecule). This renders it unsuitable for requirements calling for resistance to high temperatures. However, lead trinitrophenolglucinate crystallizes without water, so that it undergoes no loss of weight on heating for 2 hours at 170°C at a pressure of 10 mmHg. As its explosive properties are similar to those of lead styphnate, and superior at low temperatures, it is entering Service, under the designation RD 1359, in special stores where its advantages outweigh its cost. It has the structure given in Fig. 3.

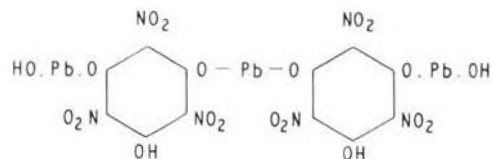

**Fig. 3 Lead trinitrophenolglucinate**

#### **Lead azotetrazole**

47. Tetrazole (Fig. 4a) and its derivatives yield explosive salts, some of which were patented as initiatory explosives in America in 1926. Azotetrazole (Fig. 4b) is one of these derivatives, and it forms a normal and a monobasic lead salt, each of which exists in two forms. Both forms ('C' and 'D') of the monobasic lead salt are free from water of crystallization and have good thermal stability.

48. Azotetrazole does not exist in the free state, but its (stable) disodium salt (the sodium atoms are associated with the 4 and 4'-nitrogen atoms) is readily made by the oxidation of 5-aminotetrazole by potassium permanganate in hot caustic soda solution. (Note: 5-aminotetrazole is made by treating

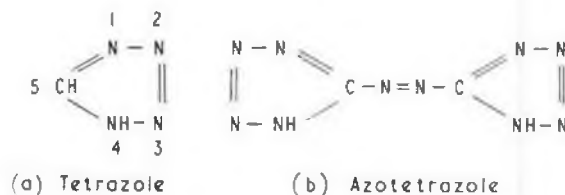

Fig. 4 Tetrazole and azotetrazole

aminoguanidine with sodium nitrite in presence of a strong mineral acid.) The disodium salt of azotetrazole crystallizes from hot water in the form of the pentahydrate, as yellow crystals.

49. Both forms of the basic lead salt are made by the addition of ammoniacal solutions of lead acetate to hot solutions of the disodium salt. The slow addition of the lead solution to the sodium salt solution at 90°C results in the production of basic lead azotetrazole of type 'D', in the form of yellow prismatic crystals of high bulk density; this product is characterized as RD 1355 and is being investigated for use in certain stab- and percussion-sensitive detonators. It is doubtful whether the type 'C' salts will find a use. The structure of the monobasic lead azotetrazoles is (Fig. 5):

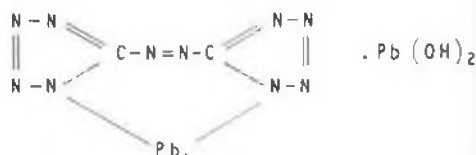

Fig. 5 Monobasic lead azotetrazoles

50. The type 'D' salts, such as RD 1355, are non-hygroscopic and do not undergo change on storage for 6 months, either at 60°C (dry) or under alternating 60°C to 70°C (humid) conditions. The ignition temperature of RD 1355 is about 222°C and its F of I is 8. It is appreciably more friction-sensitive than is mercury fulminate.

## Sensitizers

### Purpose of sensitizers

51. In the preceding paragraphs the properties of the primary explosives have been considered, and it has been shown that some of them are sufficiently sensitive to either mechanical or electrical stimuli to be used alone in some applications. However, no primary explosive has a range of properties wide enough to make it suitable for general use without inclusion of a 'sensitizer'. A sensitizer is a substance which may itself be either explosive or completely inert but which, added to a basic material or mixture, confers on it the required degree of sensitiveness. Thus, mercury fulminate itself is a sensitizer when added to a mixture of potassium chlorate and antimony sulphide, but replacement of the mercury fulminate by sulphur is almost as effective. In fact, many inert compounds derived from sulphur have been found to exert this sensitizing effect. Similarly, as indicated in para. 58, tetrazene is very effective in this role. Lead and copper thiocyanates are other examples of sensitizers. One or other of these sensitizers is an essential ingredient in any mixture which has ignitory function. In compositions based on lead styphnate, which are intended to respond to an electrical stimulus without a bridgewire, finely divided graphite is the usual sensitizer.

### Tetrazene

#### Structure of tetrazene

52. If nitroguanidine (also called 'picrite', see Chapter 6) is reduced (by the conventional methods of organic chemistry), it yields aminoguanidine, and two molecules were believed to react with two molecules of nitrous acid to yield 'tetrazene' according to the following scheme in Fig. 6.

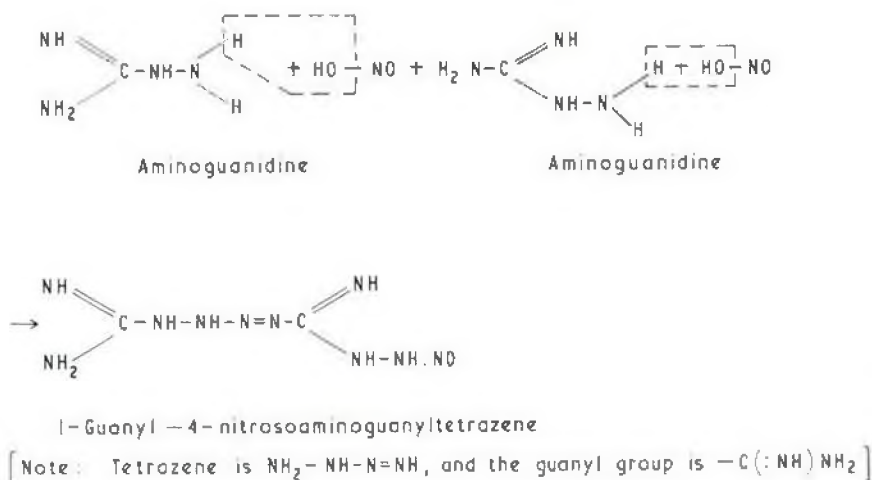

Fig. 6 Suggested reaction to produce tetrazene

53. However, American workers in 1955 argued that the final product of the reaction of aminoguanidine with nitrous acid has the structure:

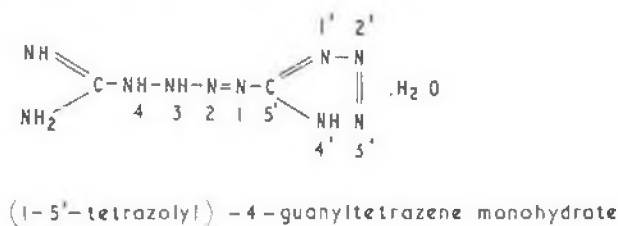

Fig. 7 Alternative suggested tetrazene end product

It has been argued that it has this structure because:

- (1) it can also be synthesized by the reaction of 5-tetrazolyldiazochloride with aminoguanidine
- (2) when it is titrated with Karl Fischer reagent, loosely-bound water reacts in nearly the correct proportion to correspond with one molecule of water of crystallization.

More recently, X-ray crystallographic studies in the Explosives Research and Development Establishment have shown that the American structure is nearly correct: the presence of a molecule of water of crystallization is confirmed, but the guanyl group is in fact in the 3-, not 4-, position in the tetrazene chain.

*Manufacture and properties of tetrazene*

54. This large molecule discussed in para. 52 and 53 is referred to in explosives technology as 'tetrazene'. In commercial practice it is made by dissolving a salt of aminoguanidine (usually the carbonate) in dilute aqueous acetic acid (using only a small excess of acid as otherwise a triazine is formed) and adding sodium nitrate at 30°C. The reaction is slow, and it is usual to allow 24 hours for completion. The product is a colourless or pale yellow fluffy crystalline material which can appear in two different crystal modifications, according to the conditions of reaction. It is not readily soluble in the usual solvents and so cannot, in practice, be purified or modified in physical form by recrystallization. Its bulk density is about 0.45 g/ml, which can be increased to 1.05 g/ml under a pressure of 1000 lb/in<sup>2</sup> (6.9 MN/m<sup>2</sup>). It has a marked tendency to agglomerate and cake on drying (which must be done at low temperature, as this product is not stable in presence of water above 75°C), and it is then hazardous to break down because of its sensitiveness (F of I is 13) and dustiness.

55. Because of the unsatisfactory nature of the physical form of the commercial product, research was done in the Explosives Research and Development Establishment to find an improved form. It was found that the presence in the reaction mixture of a suitable dispersing agent and the control of the temperature during the reaction gave, within 1½ hour, a free-flowing product of a microgranular form. This product is designated RD 1357. It is practically non-hygroscopic at 88% RH at 20°C (the commercial product is 0.8% hygroscopic at 95% RH at 30°C), and it is stable in the absence of water

to a temperature above 100°C (no change occurs in 1 hour at 100°C and 10 mmHg pressure). Like the commercial product, it can be stored under water at ambient temperature, but is decomposed by boiling water and by mineral acids and by alkalis. Because of its granular form it is conveniently dried by the cold air method used for lead azide and other initiatory salts described earlier. Its bulk density is about 0.6 g/ml, and its F of I is 11. Its explosive properties (apart from a slightly greater sensitizing effect in mixture) are similar to those of the commercial product.

56. RD 1357 is in practice made in 2½ lb (1.13 kg) batches in a standard lead azide plant, but the process could be employed on a continuous basis.

57. Tetrazene is rather more sensitive to impact than is mercury fulminate and is of similar power (as measured by the lead block test) but this falls off when it is pressed to higher densities.

58. It is not used alone. However, it has remarkable properties as a sensitizer and this constitutes its principal use in military stores. A comparatively small amount (3 to 5% by weight) markedly sensitizes lead azide to mechanical stimuli (shock, stab and percussion). Similar proportions are frequently added to cap compositions (particularly those based on lead styphnate and lead dinitroresorcinate) to achieve the required degree of sensitivity to percussion, which is maintained even when decomposition of some tetrazene has taken place as a result of exposure to temperatures at which tetrazene is not stable.

### Cap, Igniter and Detonator Compositions

#### Compositions ignited mechanically

59. Caps, igniters and detonators are the starting points of the train of explosive events which lead finally to the functioning of military stores. All may be ignited or initiated either by mechanical means (for example, by percussion) or by electrical means (for example, thermal effects on the explosive when current is passed through a bridgewire embedded in it) or by sparking when the explosive is made electrically conducting; there are also other modes.

#### Cap compositions

60. Considering first ignition of caps by percussion (for example, the percussion caps fitted to small-arms ammunition), the function of the cap composition is to impart regular and consistent ignition to the propellant of the cartridge, and the composition must meet the following requirements as far as possible:

- (1) appropriate percussion sensitivity
- (2) adequate igniting power
- (3) good chemical stability
- (4) good mechanical mixing properties, to maintain homogeneity and reproducibility of performance
- (5) safety in handling, including freedom from liability to explode *en masse* during the filling operations in the factory.

61. Additionally, cap compositions should be free from any tendency to promote muzzle flash, or to cause excessive corrosion (for example, rusting) of the bore of the weapon. No cap composition has been found which possesses all these desirable features, but a much closer approach to the ideal has become possible in recent years. In particular the ignition system for small-arms ammunition must be simple because of space considerations.

#### Compositions with mercury fulminate

62. In Chapter 2 reference was made to the earliest uses of mercury fulminate to ignite black powder in small arms; it was necessary to add potassium chlorate to the fulminate because the flash from the latter alone was too weak, but could be reinforced by hot particles of potassium chloride and mercuric oxide when chlorate was also used. The inclusion of antimony sulphide as 'fuel' produced hotter and more effective flash, and a series of compositions based on these 3 ingredients, in different proportions, came into the Service. Until a few years ago the compositions in use were as given in Table 1.

63. Finer particle-size versions of the A, B and C mixtures were employed for special purposes under the designation A.1, B.1 and C.1 mixtures. The A mixture (also known as 6:6:4 mixture), being the most sensitive and powerful, was the preferred filling for an ignitory 'detonator', while the E composition (also known as SAA composition) was filled into the percussion caps of small-arms ammunition. The intermediate mixtures found applications when some matching of igniting capability with reduction in power (brisanee) was necessary, for example, the ignition of delay compositions.

Table 1

## Cap compositions with mercury fulminate

	Composition				
	A	B	C	D	E
Mercury fulminate	37.5	11.0	32	25	19.0
Potassium chlorate	37.5	52.5	45	40	33.4
Antimony sulphide	25.0	36.5	23	35	42.8
Sulphur	—	—	—	—	2.4
Mealed gunpowder	—	—	—	—	2.4

64. All these compositions are very sensitive (F of 1 of 'A' mixture is 6 and of 'E' Mixture is 8), and they had to be made by 'jelly bag' mixing of the fulminate with (separately) premilled other ingredients, after which they were carried about the filling factory in papier-mache boxes. They were pressed into copper caps which, in turn, were pressed into a central cap chamber in the base of the cartridge case. The exposed surface of the composition in the caps was protected with a coating of a waterproof varnish, and then also with a disc of paper or metal foil.

*Compositions without mercury fulminate*

65. However, mixtures containing mercury fulminate have only a short life in damp (tropical) conditions, in spite of the varnish protection (which is not permanently resistant to the diffusion of water molecules). Accordingly, a large number of mixtures without mercury fulminate were formulated, making use of sulphur and in some instances lead thiocyanate as sensitizers, and introducing lead styphnate in many mixtures for the first time. Prior to the Second World War the cap compositions without mercury fulminate were as given Table 2.

Table 2

## Cap compositions (pre World War 2) without mercury fulminate

	Composition			
	QF	Q3	Friction tube	RD 1610*
Potassium chlorate	36.5	54.0	44.6	54.0
Antimony sulphide	54.5	40.0	44.6	13.0
Mealed gunpowder	3.0	—	3.6	—
Sulphur	3.0	6.0	3.6	—
Lead thiocyanate	—	—	—	23.0
Powdered glass	3.0	—	3.6	—
PETN	—	—	—	10.0

\*RD 1610 was a development which was never actually in British Service, but compositions containing lead thiocyanate have been used abroad, including the United States.

66. Prior to the Second World War a composition originated by Von Herz, and known as VH2, was in use for percussion cap manufacture commercially, and eventually came into British Service during the War. It has the composition:

Tetrazene	2 parts by weight
Lead styphnate	38 .. ..
Barium nitrate	39 .. ..
Calcium silicide	11 .. ..
Antimony sulphide	5 .. ..
Lead dioxide	5 .. ..

Use of barium nitrate in place of potassium chlorate largely avoids the corrosion of small-arms barrels caused by potassium chloride.

67. The long series of experimental tests and field trials of the mixtures prepared by the Research Department, Woolwich, and known as the RD 1600 series (see para. 76), led finally to a very simple mixture, designated RD 1651, proposed as a replacement for the mercury fulminate compositions A and B. It has composition:

2:4 LDNR, RD 1337 (para. 44)	50 parts by weight
Barium nitrate	45 " " "
Tetrazene	5 " " "

This composition was approved for use in British Service in 1961 and it has largely displaced the A and B mixtures. It has excellent flash-receptive and igniting capabilities, coupled with a degree of sensitiveness to stab which is slightly greater than that shown by the mercury fulminate mixtures. Its main advantage, however, lies in greatly enhanced thermal stability, and its predicted service life is 20 years. Extensive trials as a cap composition have shown that RD 1651 is a satisfactory alternative to VH2 composition, and it is approved for this purpose. It has been allotted the Service nomenclature of 'L' mixture.

#### *Detonator fillings*

68. Detonators have as their object the initiation of detonation in other explosives. They may be detonated, according to the design of the detonator, by a light blow, flash, or some other method. In recent years it has become clear that detonators should be as small as possible, consistent with their ability to perform the function for which they are designed. This is due largely to restrictions imposed on the dimensions of the 'safety and arming' mechanisms of which the detonators form part, and to safety considerations. The detonator fillings are therefore arranged to produce maximum power output, and this is achieved more readily if a small boost increment of a secondary explosive is introduced. Modern composite detonators therefore have three explosive fillings as follows:

- (1) the 'topping' charge, for example, a priming of 'L' mixture if sensitivity to stab is required. (Sometimes the topping charge is RD 1337 used alone, where only sensitivity to stab is required.)
- (2) the lead azide charge
- (3) the boost charge, usually tetryl, RDX or (occasionally) PETN.

In this way adequate detonation power is obtained from detonators having a total filling of only 2 grains (0.129g). Detailed discussion of the power of small detonators is outside the scope of this book, but it may be mentioned that small detonators are capable of initiating a tetryl stemming, through Service air gaps and metal septa.

69. Where 'large' detonators are acceptable (for example, for the direct detonation of, say, a demolition explosive charge), ASA composition has been used in the explosive train. ASA has the composition:

Lead azide	67.9% by weight
Lead styphnate	29.1% " "
Aluminium	3.0% " "

It would be initiated by, say, a commercial fuzehead and followed by a tetryl base charge.

#### **Compositions ignited electrically**

70. In this Chapter brief consideration has been given to primary explosives and to caps and detonators containing them which are functioned by mechanical stimuli (that is, by stab or percussion) or by flash. In a great many Service applications, however, functioning must be achieved by electrical means, and to meet this requirement the last decade has seen the development of many stores specially for this purpose.

71. There are two methods commonly in use which are as follows:

- (1) to utilize the electrical energy available to heat a fine bridgewire embedded in the explosive, and so ignite the explosive
- (2) to make the explosive conducting by incorporation of a suitable additive ('sensitizer') so that local ignitions occur on passage of electrical energy, which eventually propagate through the filling.

Caps, igniters and detonators have been designed on the conducting composition (CC) principle and have found a very wide use in a variety of Service applications.

72. Lead styphnate, RD 1303, is the most widely used main explosive of stores to be functioned electrically. It is made conducting when necessary by the inclusion of graphite, and RD compositions 1653 and 1654 were originally developed for this purpose, having the compositions given in Table 3.

73. These compositions were intended to replace the percussion cap fillings in 30 mm 'Aden' gun cartridges and, basically, are still in use. The proportion of graphite (now changed to DOHM'S Air Floated for most applications) determines the electrical sensitiveness which increases as the amount of

Table 3

## Lead styphnate compositions RD 1653 and RD 1654

	RD 1653	RD 1654
<b>Graphite (Acheson Grade 615) RD 1303</b>	9 to 10% to 100%	6 to 7% to 100%

graphite is reduced, so that in the N8 igniter, for which high-order sensitiveness is required, the amount of graphite is practically halved. More recently, CC detonators have been introduced into Service in which lead azide/graphite or monobasic lead azotetrazole/graphite is used as the conducting composition.

74. To enhance the flash output of such caps and igniters, a boosting increment of an RD 1600 series composition may be used. Typically, RD 1652 (consisting of barium styphnate\*, potassium chlorate and antimony sulphide) is added (for example, for the 30 mm cap), or RD 1655, in which RD 1353 replaced RD 1320, is used for the bridgewire types of igniter.

75. The most important functioning characteristic shown by caps, detonators and igniters ignited electrically is the relatively short time interval (a few milli-seconds) in which they function. This property, coupled with good storage lives (particularly when using lead styphnate), is responsible for their continually extending Service use.

**RD series compositions**

76. It may be of interest to know why RD numbers are allotted to compounds. The compounds in the RD 1300 - 1400 series represent those manufactured either in the old Research Department, Woolwich, or in the Explosives Research and Development Establishment, Waltham Abbey. The series RD 1600 - 1700 series represent the application of these compositions in suitable mixtures formulated by the Research Department, Woolwich, and more recently by the Royal Armament Research and Development Establishment, Fort Halstead. A list of commonly used RD 1300 series compositions and their applications is given in Table 4. Any questions regarding the manufacture and use of these compositions should be referred to the relevant authority, normally DERDE or DRARDE.

\*Barium styphnate as per specification RD 1320

Table 4

**A summary of some RD 1300 series compositions adopted for service in the United Kingdom and abroad**

RD No	Description	Application
1302	Lead styphnate alpha normal lead trinitroresorcinate monohydrate. Equant crystals dust-free	General applications including ASA and VH2 compositions superseded in UK by RD 1303 and RD 1367
1303	As RD 1302 chemically but special crystal size and habit, and less sensitive to electrostatic spark ignition	Mixed with powdered graphite for electric cap and igniter compositions. Ingredient for percussion cap compositions
1308	Monobasic lead 4 : 6 dinitroresorcinate precipitated with carboxy methyl cellulose	Aircraft bomb detonator delay. Torpedo electric detonator. Thermal fuzes. (RD 1353 or RD 1363 may offer improved alternative)
1320	Barium styphnate (normal barium trinitroresorcinate monohydrate). Equant crystal habit	Delay composition for fuzes
1320A	As RD 1320 but columnar crystal habit	Gas producer in electric bridgewire igniters
1320B	Barium styphnate co-precipitated with carboxy methyl cellulose	Priming composition, electric bridgewire applications

RD No	Description	Application
1333	Granulated lead azide. Lead azide precipitated with carboxy methyl cellulose	Fuze sleeves, detonators. Adopted by US Army
1336	Silver azide	Composition for detonators. Advantages in efficiency and compatibility compared with lead azide
1337	Normal lead 2 : 4 dinitroresorcinate	Delay composition and ingredient for stab sensitive and igniferous detonator and cap compositions
1339	Lead azide pure. Controlled crystal size and habit	Special applications
1340	Barium styphnate. (Normal barium trinitroresorcinate monohydrate)	Ingredient for ballistic layer of electric caps. Ingredient for bridgewire igniter composition
1343	Lead azide precipitated in presence of sodium carboxy methyl cellulose and sodium hydroxide (improved version of RD 1333)	Composition for detonators
1346	Free flowing form of beta monobasic lead styphnate	Ingredient of priming compositions
1347	Free flowing form of RDX crystallized in presence of methyl cellulose	Fuze channels, detonators. Advantages in flowing and consolidation properties
1349	Beta monobasic lead styphnate, modified particle size and shape to RD 1346)	Ingredient of priming composition. Fuzehead composition
1352	Improved process and product of dextrinated lead azide	Composition for detonators
1353	Improved process and product of monobasic lead 4 : 6 dinitroresorcinate	Priming and delay composition. Ingredient of igniferous compositions for bridgewire igniters
1355	Basic lead azotetrazole 'D' form, high density	Conducting and stab sensitive initiating composition of improved thermal stability
1357	Tetrazene, improved process and product	Sensitizer for igniferous and cap compositions
1358	Lead 4 : 6 dinitroresorcinate (Low Pb type)	Fuzehead composition, for igniferous applications
1359	Normal salt lead trinitrophenylglucinate A type	Narrow channel initiator trains and boost composition. Applicable over extended temperature range
1361B	Tribasic normal lead styphnate incorporating 12 per cent boron within the crystals	Igniferous compositions for wire bridge igniters and fuzeheads; non-violent; extended temperature range of application
1362 LD	Lead oxide incorporating 3 to 5 per cent boron within the crystals. Low density, orthorhombic	Combustion promoter. Used with ethyl cellulose to replace nitrocellulose as binder for fuzeheads
1362 HD	As RD 1362 but high density, tetragonal	Delay and priming composition
1363	Dibasic lead 4 : 6 dinitroresorcinate	Delay composition and gas producer
1365	Barium chromate/boron co-precipitated B $\approx$ 10 per cent	Delay composition, faster burning than RD 1368
1367	Normal lead styphnate (commercial process)	More economic version for use in cap compositions
1368	Barium chromate/boron co-precipitated $\approx$ 4.5 per cent	Delay composition, applicable to grenade trains

CHAPTER 10

Pyrotechnic Compositions

<b>CONTENTS</b>		<i>Para</i>
<b>General</b> .....		1
<i>Nature of pyrotechnics and pyrotechnic compositions</i> .....		1
<b>Gunpowder</b> .....		5
<b>Magnesium and oxidants</b> .....		6
<b>Illuminating and signal compositions</b> .....		13
<i>Production of white light</i> .....		17
<i>Production of red light</i> .....		19
<i>Production of green light</i> .....		20
<i>Production of blue light</i> .....		21
<i>Binding materials</i> .....		24
<i>Photoflash fillings and compositions</i> .....		30
<b>Tracer composition</b> .....		34
<b>Smoke Compositions</b> .....		36
<i>Screening smoke</i> .....		37
<i>Markers and signals used at sea</i> .....		40
<i>Screening smoke (chemical)</i> .....		41
<i>Coloured-smoke signals</i> .....		43
<b>Flame and heat-producing compositions</b> .....		46
<i>Igniters</i> .....		46
<i>Delay composition</i> .....		54
<i>Incendiary materials</i> .....		59

**Illustrations**

<i>Fig</i>		<i>Page</i>
1	Luminosity versus rate of burning .....	6

**Tables**

<i>No</i>		
1	Illuminating compositions .....	7
2	Signal compositions .....	8

## CHAPTER 10

## Pyrotechnic Compositions

**General***Nature of pyrotechnics and pyrotechnic compositions*

1. 'Pyrotechnics' are stores containing pyrotechnic compositions. As noted in Chapter 2, they have a long military history which commenced with rudimentary rockets and evolved in parallel with the development of civilian 'fireworks'. When Congreve and others in the 19th century developed larger and better rockets for military purposes it was soon realized that these could be used to carry stores which would illuminate enemy positions or would give light or smoke signals. The military use of pyrotechnics received a strong impetus with the development in the First World War of trench and aerial warfare, and from then until the present time pyrotechnics have developed in the British Service to meet increasingly stringent requirements; but their functions remain broadly to produce light, smoke or fire and incendiary effects and, in special instances, to measure intervals of time.

2. Pyrotechnic materials are rarely individual substances and until recently have usually consisted of physical mixtures of finely divided combustibles and oxidants filled into appropriate stores so that the mixtures on ignition either explode (to produce a flash of light or a loud bang) or burn steadily. More recently the combustible matter has tended to include suitable synthetic rubber as both fuel and matrix for the remaining ingredients of the composition. The choice of other fuels is very wide, including some metallic elements and alloys. The choice of oxidants is rather restricted, a few oxygen-rich salts and some oxides and halides. A restriction on the use of all ingredients of pyrotechnics is that they shall be as non-hygroscopic as possible, although the adoption of improved materials of construction and sealing for the containers of pyrotechnics (to replace the time-honoured paper and glue) gives a certain tolerance in this regard if manufacture and filling of compositions are carried on under reasonable conditions of humidity control.

3. Like gunpowder, whether a pyrotechnic composition burns explosively or whether it burns steadily depends on its degree of compression and therefore on its free surface; loosely packed powders burn explosively, while compositions consolidated into a column and surrounded by non-combustible, heat-insulating material burn regularly, layer by layer, if ignited at one end.

4. Pyrotechnic compositions intended to produce light are required in three main fields: (1) illumination (including 'photoflashes', in which the peak light intensity is synchronized with a camera shutter), (2) signals (including tracking flares for missiles) and (3) tracer ammunition. Compositions to produce smoke are required either to give a screening effect or for signals: a special variant of the latter is a composition to give both smoke and flame for use at sea (for example, for ejection from a submarine). Compositions to produce flame and/or hot matter are required for igniters, primers and incendiaries. Besides these, there is a requirement for compositions capable of yielding highly reproducible times of burning for delay systems and time fuzes; like some of the other compositions these may be required to function at high altitude without the reduced barometric pressure or temperature causing any significant change in their performance; they must also be unaffected by acceleration or spin of the store in which they are used.

**Gunpowder**

5. Gunpowder (see Chapter 7) continues to play an important role in pyrotechnics in spite of the difficulties of manufacturing it reproducibly and of controlling its moisture content. Substitutes have been sought, but nothing has been found possessing all its advantages and none of its disadvantages. It has a wide range of uses (as a propellant, a burster, an igniter, a primer, a delay - timed or not) and is remarkably compatible with other chemicals in a pyrotechnic store, so that altogether it seems unlikely that a complete replacement for it will be found.

**Magnesium and oxidants**

6. Another important ingredient of many pyrotechnic compositions is magnesium powder (Chapter 5). It is employed wherever a high output of light or heat is required. An important consideration in its use is its particle-size, which is a major feature of its commercial grading and is defined in the Specification

---

\*A curious old book printed in 1653 and entitled 'The Schoole of Artificial Fireworks' has a chapter on 'Necessary and serviceable fireworks both for Land and Sea execution, and first for the pike, giving complete instructions for the manufacture of rockets, their filling, stars and priming. The body was made of strong paper filled with a mixture of mealed gunpowder and coal dust. The stars were made of a mixture of mealed powder, saltpetre, sulphur vivum, aqua vitae and oil of spike, moulded inside a paper container one end of which was dusted with powder while the remaining surface was covered with glue.

CS 787F. The particle-size distribution of the coarser powders is determined by sieving, that of the finer powders by measurement of the rate of settling of the particles in a temperature-controlled atmosphere by means of a Micromerograph\*. Because the state of subdivision of magnesium powder profoundly affects the manner in which compositions containing it burn and because its own combustion is a surface effect, it is convenient to measure its specific surface ( $\text{cm}^2/\text{g}$ ) by determining the permeability of a packed bed of the powder to a gas or liquid; the method is described by Carman (J. Soc. Chem. Ind., 1938, 57, 225) and a convenient apparatus is the Fisher Sub-Sieve Sizer. The specific surface of a particular size grade of magnesium powder can vary greatly, depending on the shape as well as size of the particles; variation of shape is, of course, more marked with 'cut' or 'flake' than with 'blown' powders. (The terms cut, flake and blown refer to magnesium powders produced by particular manufacturing methods — see Chapter 5).

7. The surface of magnesium tends to oxidize, particularly in the presence of moisture. It is therefore usual to cover the surface with a thin protective coating (for example, of a resin such as acaroid — applied by stirring the magnesium powder in an alcoholic solution and drying).

8. In light-producing compositions, magnesium is used in admixture with oxidants, those most commonly employed being the nitrates of sodium, potassium, barium and strontium, and potassium perchlorate. In the presence of moisture, magnesium will react with nitrates to form ammonia and until 1923 sodium nitrate had never been used in admixture with magnesium because it was considered too hygroscopic. Perhaps because the purity of commercial sodium nitrate had then improved (because of its manufacture from synthetic nitric acid, whereas it had formerly been prepared by the recrystallization of imported Chile saltpetre), it was found in the Research Department, Woolwich, that the salt was not sufficiently hygroscopic to prevent its use as an oxidant and, moreover, mixtures of magnesium and sodium nitrate were the most efficient light producers so far devised. It was necessary only to ensure that the relative humidity in the workshops in which the mixture was made and filled did not exceed 75% (a rare condition in this country) to avoid significant absorption of moisture. The specific light output of such compositions may be as high as 45 000 candleseconds/gramme. The efficiency of such compositions in converting chemical energy into light may be derived from the heat of combustion (measured in a bomb calorimeter) and the specific light output by the equation

$$\text{Efficiency (lumens per watt)} = 2.99 \times \frac{\text{Specific light output}}{\text{Heat of combustion}} \quad \text{--- (1)}$$

This efficiency rises from about 20 lumens per watt for a composition containing 20% magnesium to about 50 lumens per watt for one containing 60% magnesium, and thereafter declines rapidly.

9. Spectro-photometric studies of the flames from burning mixtures of magnesium with potassium, barium and strontium nitrates show a striking difference compared with magnesium/sodium nitrate mixtures. Whereas the spectral energy curves for the former systems show a more or less continuous rise from the blue end of the spectrum to the red, that for the sodium nitrate mixture shows a steep rise to two equal peaks on either side of the sodium doublet followed by a rise of the general form to the red end of the spectrum. The outer envelope of the flame from the sodium nitrate mixture consists of a layer of burning sodium vapour, which is the source of the additional luminosity of such mixtures. The barium and strontium systems afford no evidence of the presence of metal vapour in their flames, while the mixtures containing potassium nitrate have metallic potassium in their flames but its emission is in the violet and the red with little contribution to the useful luminosity.

10. Barium and strontium nitrates melt at considerably higher temperatures than does sodium nitrate ( $307^\circ\text{C}$ ), and burning compositions of them with magnesium are therefore more physically stable and less liable to throw off burning lumps (for example, in stars on parachutes, which burn flame downwards). If chloride ions are present in the flames of such compositions the light emissions contain the characteristic green of  $\text{BaCl}^+$  or red/orange of  $\text{SrCl}^+$ . Such chloride ions may be derived from the use of potassium perchlorate as an oxidant (yielding potassium chloride as combustion proceeds) or from organic chlorine compounds. (The use of metallic chlorides in the composition itself is not practicable because of their potentially corrosive effect on the magnesium.)

11. The use of barium peroxide with magnesium yields compositions which burn with small, hot, white flames and virtually without formation of gas, so that their rates of burning are little affected by variation in atmospheric pressure and they are particularly useful at high altitudes.

\*Micromerograph: In this instrument a small weighed quantity of the powder is scattered into the top of a tall cylinder filled with nitrogen and the particles settling at the bottom of the cylinder are collected on the pan of an electronic balance and weighed continuously. The sizes of the particles thus collected are deduced from considerations of Stokes's Law.

12. Chlorates, permanganates and dichromates form sensitive mixtures with magnesium and are avoided as much as possible. The nitrates of heavy metals are very prone to reduction by magnesium and such mixtures are unstable.

#### **Illuminating and signal compositions**

13. Illuminating and signal compositions are required to provide steady sources of light, in the one instance to illuminate targets for visual or photographic reconnaissance and in the other to penetrate considerable depths of atmosphere to give distinctive signals identifiable against adverse backgrounds. A light-giving store must satisfy three basic requirements: (1) that it burns for the correct time, (2) that it has the appropriate luminosity and (3) that the colour of its flame is correct in hue and as saturated as possible. Whatever the fulfilment of these requirements may owe to other features of the store it is basically dependent on the nature of the composition.

14. Light suitable for illumination is yellowish-white or white in colour, and the greatest luminosity is produced by compositions containing sodium nitrate (yielding Na atoms and  $\text{NaH}^+$  ions in the flame) and barium nitrate (yielding  $\text{BaO}^+$  ions in the flame). Signal flames, which are required to be coloured (red, green, yellow or sometimes blue), are on the whole less intense than the equivalent illuminating flames.

15. The rate of burning (measured in seconds per inch for pyrotechnic compositions, instead of inches per second as with propellants) and the luminosity (kilo-candles per  $\text{in}^2$ ) of a composition are both closely linked to its heat of combustion; the hotter mixtures burn faster and produce brighter flames than cooler mixtures. If the luminosity is plotted against the rate of burning, a smooth almost hyperbolic curve is obtained. For illuminating compositions (Fig. 1a) it ranges from 400 k-candle/ $\text{in}^2$  at 2 sec/in to 10 k-candle/ $\text{in}^2$  at 40 sec/in, while red compositions (Fig. 1b) range from 80 k-candle/ $\text{in}^2$  at 4 sec/in to 10 k-candle/ $\text{in}^2$  at 30 sec/in and green compositions (Fig. 1c) from 60 k-candle/ $\text{in}^2$  to about 8 k-candle/ $\text{in}^2$  over the same range of rates of burning.

16. The spectra of illuminating and coloured signal flames are composed of three distinct elements: (1) a general temperature continuum which is the main source of the white light which is always present; (2) complex systems of band-spectra derived from molecular emitters such as ionized oxides and chlorides; (3) line spectra derived from the atomic emitters, magnesium, sodium, strontium, etc.

#### *Production of white light*

17. The production of white light is encouraged by several methods: (1) by raising the temperature to increase the thermal excitation — this is normally achieved by increasing the proportion of metals such as magnesium and aluminium to increase the rate of burning; (2) by developing an extensive continuum such as that of sodium; (3) by exciting extensive band systems such as that of  $\text{BaO}^+$ ; (4) by exciting simultaneously two more or less complementary band systems such as those of  $\text{BaCl}^+$  and  $\text{SrCl}^+$ . Methods (1) and (2) are employed in very intense illuminating compositions (for example, SR 580), method (3) in compositions of magnesium and barium nitrate (for example, SR 343) and method (4) in compositions of magnesium with barium and strontium nitrate and a source of chlorine (for example, SR 595).

18. When sodium is introduced into an illuminating composition the flame exhibits a very strong emission in the continuum 5500-7000 Angstroms, and the intensity of this emission appears to be connected with the formation of  $\text{NaH}^+$  ions in the flame, which is encouraged by the addition of certain organic matter such as linseed oil products to the composition.

#### *Production of red light*

19. Red flames are produced by the introduction into the composition of strontium compounds, usually in the presence of a source of chlorine. The colour of the flame is derived from two distinct band systems; that of 6200-6800 Angstroms is due to strontium chloride, and another at 6000-6900 Angstroms is due to strontium oxide.

#### *Production of green light*

20. Green flames usually depend on the spectral band 5050-5350 Angstroms emitted by barium chloride. The saturation of the colour is much impaired by the wideband emission (4000-8000 Angstroms) from  $\text{BaO}^+$ , and good green flames of high intensity are not possible with barium compounds, alternatives to which are not very promising, although boron (giving rise in the flame to  $\text{BO}^+$ ) has given a measure of success.

#### *Production of blue light*

21. Blue flames rely for their colour on the band system of  $\text{CuCl}^+$ , ranging from 4200 to 4600 Angstroms, but the saturation of the colour is much reduced by relatively small proportions of light

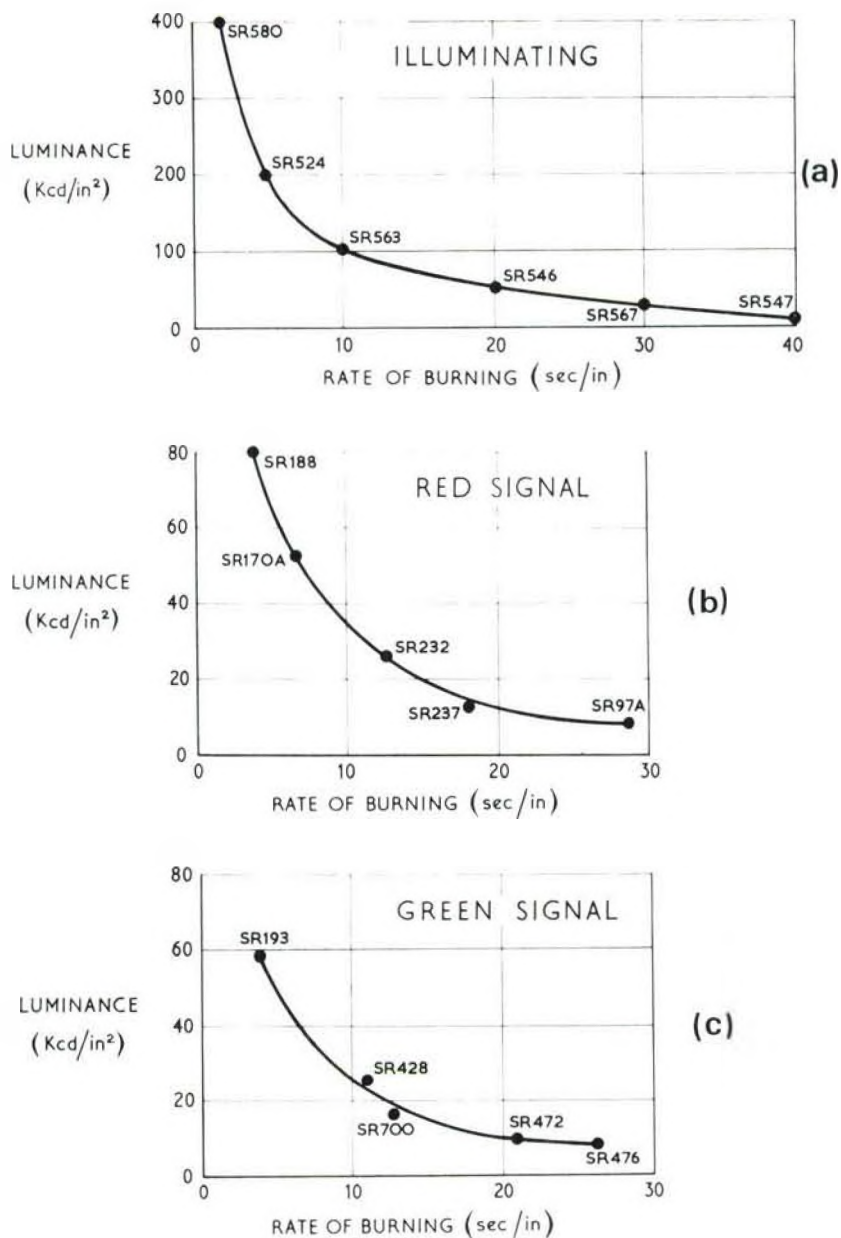

$$1 \text{ cd/in}^2 = 1550 \text{ cd/m}^2$$

**Fig. 1 Luminosity versus rate of burning**

from secondary emitters. Moreover, the energy emission of the source and the sensitivity of the human eye are both low in the blue region of the spectrum. Blue signal compositions cannot contain magnesium and so cannot be used in daylight because their flames are not bright enough.

22. It has already been noted that magnesium is the principal fuel employed in light-producing compositions because of the high luminosity which it imparts, for which reason it is preferred to aluminium in spite of the greater stability of compositions based on the latter.

23. Oxidants, besides yielding oxygen in which to burn the fuel, may also be chosen to modify the colour of the flame by providing appropriate atomic or molecular emitters, and to modify the products of combustion and so affect its smoothness and regularity.

*Binding materials*

24. Since light-producing compositions are generally employed in consolidated form it is usual to incorporate in them a binding material which, besides increasing the cohesion under pressure between the particles of the other ingredients, has the following other functions:

- (1) to protect the magnesium powder from corrosion by the electrolytes employed in the composition in the presence of any occluded moisture
- (2) to modify the rate of burning of the composition
- (3) to enhance the luminosity or colour of the flame
- (4) to modify the sensitiveness of the mixture to ignition by friction or blows.

25. Over the years a wide range of waxes, drying oils, varnishes and resins has been drawn on for binding materials, but more recently use has been made of chlorinated rubbers, Thiokol rubber (an organic polymer containing sulphur linkages) and silicone rubber (a silicon 'oxide' polymer in which organic radicals are attached to the polymer framework). Apart from their effects on the pyrotechnic properties of the compositions, the choice of binding agent may also be dictated in some degree by its effect on filling properties (flow in machines, non-segregation of ingredients, pelleting power), ignitibility, sensitiveness and waterproofing.

26. Polyester resin and Thiokol rubber are among the more promising new binding materials. The former is incorporated with the other ingredients as a low-molecular-weight material in liquid form together with an organic peroxide catalyst which completes the polymerization *in situ* to give a very strong, rockhard, waterproof pellet. The proportion of Thiokol rubber which has to be employed is high (15% to 20%) compared with the 3% to 7% of binder usually used: the compositions in which it is employed are extruded in a plastic state into moulds or containers and 'cured' to a rubbery state by heating to 70°C for 24 hours. They are water-proof, resilient and relatively insensitive to friction and impact, but require good ignition.

27. Of course, the binding agents are coolants, lowering the flame temperature and retarding the rate of burning. However, it is sometimes necessary to employ additional moderants, most of which have been adopted by 'trial and error'. Cellulose, starches, sugars and resins have been used, but some of these are too hygroscopic to be satisfactory. Carbonates, oxalates, formates and citrates of elements such as calcium have been much used, their effect depending on the absorption of heat in their decomposition and on the oxide slags to which they must give rise and which modify the nature of the burning surface. When choosing them, regard must be paid to their effect on the colour of the flame; if they are gas producing they will enlarge the flame, which may be useful but may merely result in diffuseness.

28. It was remarked in para. 21 that blue compositions cannot contain magnesium because its white light would mask the blue. There are a few other non-magnesium signal compositions in Service for use in stores restricted to the hours of darkness under conditions where the required visual range is relatively short. In such instances the fuel used is acaroid or shellac resin, starch or lactose, while the oxidant is potassium nitrate or potassium or ammonium perchlorate. If a white flame is required, antimony, antimony trisulphide or arsenic trisulphide is mixed with the carbonaceous fuel.

29. Some typical illuminating and signal compositions are given in Tables 1 and 2, respectively.

**Table 1**  
**Illuminating compositions**

Composition	Ingredients	Per cent by weight	Linear rate of burning sec/in	Intensity candles/in <sup>2</sup> of burning surface	Luminous efficiency, candle-sec/g of composition
Star shell composition SR 563	Magnesium powder, grade O	50	12	100 000	35 000
	Lithographic varnish	4			
	Sodium nitrate	46			
Parachute flare composition SR 562	Magnesium powder, grade O	49	18-20	50 000 70 000	35 000 40 000
	Lithographic varnish	5			
	Sodium nitrate	39			
	Calcium oxalate				
Illuminating cartridge composition SR 580	Magnesium powder, grade IV	60	2	350 000 400 000	28 000
	Acaroid resin	4.5			
	Sodium nitrate	35.5			
Star shell composition SR 343A	Magnesium powder, grade O	50	11	46 000	15 000
	Paraffin wax	5			
	Barium nitrate	40			
	Calcium oxalate	5			

**Table 2**  
**Signal compositions**

Colour	Composition	Ingredients	Per cent by weight	Rate of burning sec/in	Intensity candles/in <sup>2</sup>	Luminous efficiency candle sec/g
Green	SR 477	Magnesium powder, grade IV Boiled linseed oil Potassium perchlorate Barium chloride Starch	40 6 34 10 10	15	11 500	6 400
Green	SR 429	Magnesium powder, grade V Boiled linseed oil Potassium perchlorate Barium chlorate Lactose	48 4 30 12 6	6	48 000	10 400
Green	SR 193	Magnesium powder, grade V Barium nitrate Alloprene (chlorinated rubber)	36 46 18	4	26 000	4 000
Red	SR 297B	Magnesium powder, grade IV Boiled linseed oil Potassium perchlorate Strontium oxalate Acaroid resin	50 2 30 10 8	5	68 000	13 800
Yellow	SR 581	Magnesium powder, grade III Acaroid resin Sodium nitrate Ivory nut	40 4 48 8	7	91 000	24 600
Blue	SR 405	Potassium perchlorate Lactose Basic copper carbonate Mercurous chloride	48 22 8 22	33	200	171
Red	SR 307A	Potassium perchlorate Ammonium perchlorate Strontium oxalate Acaroid resin	28.5 33.0 26.5 12.0	37	380	280
Green	SR 475	Ammonium perchlorate Barium nitrate Acaroid resin	43.0 44.0 13.0	30	350	300

*Photoflash fillings and compositions*

**30.** The operation of early types of photoflash depended on the rapid scattering in the atmosphere of finely divided aluminium or magnesium powder that had been ignited by a dispersing explosive charge and continued to burn with the support of atmospheric oxygen. The light from the flash grows in intensity to a maximum within milliseconds of initiation and then diminishes more or less slowly as the luminous cloud expands and cools. The products of combustion are mainly solid oxides of high reflectivity and light emission from the cloud is confined to an outer shell a few millimetres in thickness. The bursting charge (which may be of gunpowder, a pyrotechnic composition or a high explosive) is housed in a cylinder which is surrounded by an annular space packed with the metal powder.

**31.** Magnesium is more difficult to ignite than flake aluminium, and with an HE burster it tends to sinter into a compact mass without igniting; magnesium is therefore used only with gunpowder or pyrotechnic bursters, and the resulting flashcloud burns relatively slowly and the light intensity rises slowly to a relatively low rounded peak. HE is best employed with flake aluminium, the burster charge being about one-third of the weight of metal powder, and loaded in the form of pellets; tetryl, torpex and aluminized TNT (30% Al) are used. A larger and hotter flash without adverse effect on the shape of the intensity/time curve is obtained if a conical burster charge of 'lean' torpex (30 Al/50 TNT/20 RDX) is used instead of a cylindrical burster of aluminized TNT; the base of the cone has a diameter equal to that of the photoflash and is situated at the rear end.

32. A great advantage of this type of metal powder/burster photoflash is its inherent safety in relation to the effects of penetration by small arms ammunition or shell fragments. If the light composition were a mixture of metal powder and oxidant there would be immediate explosion when penetrated, whereas the aluminium powder will only inflame, leaving a reasonable chance of jettisoning the damaged photoflash before the burster explodes. However, this type of photoflash was not an efficient light producer (generating only 2.5 lumens per watt compared with, say, 27 lumens per watt from a tungsten-filament projection lamp) and the increasing stringency of Service requirements made it necessary to seek improvement. This was first done by employing a double-annular filling round the burster, in which the inner annulus is filled with powdered oxidant (potassium perchlorate, barium nitrate or a mixture of these) and the outer annulus with aluminium powder. The detonation of the burster core forcibly mixes the ingredients and ignites the metal. Such a store was reasonably invulnerable to penetrating projectiles and fragments, and so less hazardous to the aircraft carrying it than the later photoflash which is filled with an intimate mixture of metal powders and oxidants which is so rapidly ignited and explosive as not to require the assistance of an HE charge.

33. This latest type of photoflash has used as fuel, magnesium and aluminium powders, mixtures of the two, and powdered magnesium-aluminium alloy; and as oxidant, sodium, potassium, barium and strontium nitrates and potassium perchlorate. Although the use of potassium perchlorate leads to the highest peak light intensities, compositions containing it are very sensitive; attempts to reduce this sensitivity (for example, by adding powdered graphite as a lubricant) result in considerable impairment of the light characteristics of the flash. The best results for a high-peak-intensity flash, reached in a short time, are obtained by the use of fine (less than 5 microns) 'blown' aluminium powder in conjunction with either potassium perchlorate or a mixture of the latter with barium nitrate; such compositions can be formulated to produce 11 000-11 500 candle-sec/g and to reach peak intensity in 2 to 5 milliseconds; for example, SR 812 which contains equal weights of atomized aluminium and potassium perchlorate (a United States composition of comparable intensity contains 40% aluminium, 30% barium nitrate and 30% potassium perchlorate).

#### Tracer composition

34. A special type of light-producing composition is the projectile 'tracer' composition. The composition in the tracking flare of a missile burns more rapidly than it otherwise would because of the motion of the missile, whilst the luminosity is reduced by cooling of the emergent flame; the high rate of spin and the high velocity of a shell or small-arms round enhance these effects. Moreover, the composition in a tracer must withstand the initial firing stresses on the projectile. A composition SR 372 for shell tracers (red) is based on resin-coated magnesium, strontium nitrate and wax, while SR 458 for small-arms ammunition consists of a mixture of potassium dinitrophenate and barium peroxide.

35. It is important that tracer compositions shall be so pressed into their cavities that flash from the burning propellant cannot penetrate between the wall and the composition, thus shortening the time of burning. Tracer compositions are sometimes covered with a thick layer of a more slowly burning igniter composition: (1) in order to avoid too much glare in the eye of the observer/gunner at short range and (2) in order to avoid emitting so much light all along the trajectory as to disclose to the enemy the point of origin. This *dark ignition* is usually obtained by the use of sulphurless gunpowder, SFG 12, which in turn ignites a hotter composition to fire the actual tracer composition.

#### Smoke compositions

36. It was remarked earlier that there are military requirements for screening smokes and signal smokes. The means by which these requirements are met are rather *ad hoc* and have not much in common.

##### Screening smoke

37. A screening smoke is generally a white or greyish-white aerosol which may be produced by pyrotechnic or chemical means or by vapourizing heavy mineral oils which condense in the atmosphere in tiny droplets. The minute particles or droplets of the aerosol act as nuclei on which atmospheric moisture condenses (as in natural fogs), so that their effectiveness is dependent on the prevailing relative humidity. This dependence is not the same for all aerosols, nor is the order of effectiveness of aerosols the same at different relative humidities; thus, ideally the smoke agent should be chosen to suit the atmospheric conditions.

38. The pyrotechnic screening smoke compositions are based on the reaction of either zinc or calcium silicide with a chlorinated hydrocarbon in the presence of zinc oxide, essentially to produce aerosols of zinc chloride and carbon with, in the second example, calcium chloride and silicon hydroxide. These are known as Berger compositions and there are two main types, one containing zinc powder and zinc oxide with carbon tetrachloride (absorbed in kieselguhr or magnesium carbonate), and the other containing

hexachloroethane (a solid), calcium silicide and zinc oxide. The reactions of zinc and calcium silicide with the chlorohydrocarbons are exothermic and may be written as:



The heat evolved, together with secondary reactions, results in the reaction of the zinc oxide and its ultimate conversion to zinc chloride, which is the main smoke-producing product.

39. Typical screening smoke compositions are:

SR 234	—	Carbon tetrachloride	45	parts	by	weight
		Zinc powder	20	"	"	"
		Zinc oxide	28	"	"	"
		Kieselguhr	7	"	"	"
SR 264A	—	Hexachloroethane	45	"	"	"
		Calcium silicide	10	"	"	"
		Zinc oxide	45	"	"	"

Both types of composition are subject to spontaneous heating and ignition in the presence of moisture, and this may be catalyzed by the presence of impurities (particularly metal chlorides) in the composition. For this reason it is usual to add to such compositions 2 or 3% of an oxidizing agent such as potassium nitrate or sodium chromate.

#### *Markers and signals (used at sea)*

40. Some pyrotechnic stores used at sea as markers or signals are required to give visible indications both by day and by night for extensive periods. The basis of the filling of these stores is red (amorphous) phosphorus which, when ignited, burns with a lambent yellow flame and emits a dense white smoke. Composition SR 414 contains red phosphorus (coated with a little mineral oil), magnesium powder, calcium silicide and manganese dioxide; when it is ignited, part of the phosphorus together with the metal and silicide react exothermically with the dioxide and thus volatilize the rest of the phosphorus, which burns in the atmosphere. Composition SR 622 contains oil-coated red phosphorus, calcium sulphate and oxalic acid; when it is ignited the calcium sulphate reacts with some of the phosphorus to yield phosphorus sulphide which vapourizes with the rest of the phosphorus to burn in the atmosphere; the purpose of the oxalic acid is to provide additional gas to maintain an internal pressure sufficient to prevent ingress of seawater through the flame-vent of the store (red phosphorus is prone to extinction by water). Other sea-markers utilize the reaction between water and the phosphides of calcium, aluminium or magnesium to produce spontaneously ignited phosphine,  $\text{PH}_3$  (with  $\text{P}_2\text{H}_4$  as an impurity).

#### *Screening smoke (chemical)*

41. The 'chemical' screening smokes are produced either by the combustion of white phosphorus (which may be melt-loaded into shells, bombs or grenades) or by spraying into the atmosphere liquids (chlorosulphonic acid, titanium tetrachloride or silicon tetrachloride) that are readily hydrolyzed by moisture to yield hydrochloric acid, with simultaneous formation of droplets of sulphuric acid or particles of titanium or silicon dioxides, all of which substances act as additional nuclei for fog formation. The combustion of phosphorus gives a very effective dense white smoke, most useful in a light breeze. In still air, the great heat of reaction (6000 cal/gm) tends to cause 'pillaring' of the smoke as well as to give rise to secondary fires.

42. Apart from the heating (or vapourizing) of hydrocarbon oils to produce screening smokes (for example, 'funnel smoke'), a good black smoke may be produced on the small scale by generators containing anthracene and an oxidizing agent such as potassium perchlorate in suitable proportions, or containing aromatic hydrocarbons such as benzene or naphthalene and a chlorinated hydrocarbon such as carbon tetrachloride or hexachloroethane, systems which react vigorously when strongly heated to produce clouds of carbon and hydrochloric acid. [Note: For this reason, carbon dioxide fire extinguishers may be preferable for use against some burning hydrocarbons.]

#### *Coloured-smoke signals*

43. Coloured smoke signals are used in daylight only and in practice only five colours are used in Service. Orange, which is the most easily recognized colour against grey seas and skies, is universally used as a 'distress' signal colour. The other four, selected for their distinctiveness under most weather conditions, are red, yellow, green and blue. To obtain adequate smoke density it may be necessary to burn a composition at a rate of 1 lb per minute. Coloured signal smokes can be produced by: (1) chemical reactions which generate them, (2) dispersing finely divided coloured materials, (3) by vapourizing dyestuffs. In practice, only the last method is satisfactory from the standpoint of volume of

smoke and density of colour. Coloured smokes are used in two ways, either as an instantaneously produced 'puff' or 'smoke-burst' or as a steady smoke evolution over a period lasting from a few seconds to several minutes. In the coloured smoke-bursts produced by shell the combustible part of the filling may be either a mixture of nitro-cellulose powder and inorganic nitrates or pentaerythritol tetranitrate coated with wax; these 'fuels' are mixed with the powdered dyestuff and the mixture exploded by a suitable detonating system.

44. In the longer-burning signals the dyestuff is mixed with a combustible vapourizer mixture which should not be too hot (to avoid decomposing the dyestuff) or smoky (to avoid degrading the colour of the dye-vapour); mixtures of lactose or sucrose with potassium chlorate meet these conditions. The three properties, related to chemical constitution, which determine the suitability of a dyestuff for use in a signal composition are volatility, thermal stability and purity of colour. The dyestuffs should have a molecular weight not above 450 and should sublime unchanged below 350°C; the anthraquinone dyes are the most suitable. Pellets of the slower-burning smoke compositions will not ignite satisfactorily from an igniter without the assistance of a (not too hot) primer.

45. Some HE shell are fitted with 'smoke boxes' to ensure the formation of a marker smoke cloud at the point of burst. These are filled with red phosphorus.

### Flame and heat-producing compositions

#### *Igniters*

46. There is a requirement for a range of compositions to ignite explosive and non-explosive materials, and this requirement is met by pyrotechnic compositions of one kind or another. 'Igniter' compositions for propellant explosive systems give hot flames, usually accompanied by sparks and hot gases, for relatively short times. 'Priming' compositions give hot slags, sometimes without production of gas. 'Incendiary' compositions produce hot flames and large evolution of heat, together with molten iron when 'Thermite'-type mixtures are used.

47. Gunpowder for long discharged both 'igniter' and 'primer' functions, receiving its own primary ignition from the application of a flame or red-hot iron in the earliest days, later from the spark from a flint-lock, and later still from the flash from a fulminate/chlorate cap; to this day gunpowder may be so used in conjunction with the more modern caps and primary igniters. But the development of pyrotechnic compositions has rendered available a wider range of ignition and priming compositions to meet special requirements which may arise from the nature, size and shape of the system to be ignited. Just as in the initiation of an explosive system it is necessary to build up the impulse from the initial shock or flash to the final mass detonation, so in the ignition of propellants and pyrotechnic systems it is necessary to build up the thermal effect from the primary igniter until the whole exposed surface of the propellant or pyrotechnic charge is burning in a self-sustaining manner. The subject has an analogy with the lighting of a coal fire where the application of a primary igniter (a match) alone will not serve to light a heap of coals but the intervention of an 'igniter' in the form of paper may get small coals alight while larger coals require the supplementary 'priming' effect of sticks or a fire-lighter; much depends on the size (surface area) and on the nature (for example 'softness' or 'hardness') of the coal. The surfaces and ignition temperatures of pyrotechnics and propellants are important controlling factors also; sometimes an igniter alone will serve while in other instances it must be supplemented by a primer (some priming compositions used in pyrotechnic stores do not need the intervention of an igniter between themselves and the primary source of ignition).

48. The fairly large charge of cordite or composite propellant in rocket motors and of cordite in engine-starter cartridges can be ignited directly by a suitable and suitably placed igniter charge of the pyrotechnic composition SR 371C, consisting of acaroid resin-coated magnesium and potassium nitrate. The kerosene/air mixtures in a ramjet engine can be ignited with SR 623, a mixture of magnesium with barium and strontium nitrates which will function even at medium to high altitudes, while the ignition of kerosene/liquid oxygen in a guided-missile motor can be effected by SR 666, a mixture of boron, aluminium, potassium perchlorate and Thiokol rubber.

49. In the field of pyrotechnics it is not unusual to press on to the surface of the less readily ignitable main compositions a layer of a more readily ignitable priming composition which transmits sufficient heat as it burns to ignite the surface below. Such priming compositions (apart from being compatible with those with which they are to be used and not being too sensitive) should be readily ignitable from a primary igniter (cap, electric igniter, safety fuze, *etc.*), should generate plenty of heat, should not burn too rapidly or violently, and should produce some non-volatile products of combustion in the form of a fusible or solid slag (because the hot gaseous products of combustion are carried away from the surface to be ignited, which must obtain its heat by conduction).

50. Apart from gunpowder and similar compositions, priming compositions fall into two other groups: one includes organic substances combined with oxidants (usually potassium or barium nitrates) and the other includes mixtures which produce slags with little or no gas.

51. Compressed gunpowder burns too rapidly and to reduce its rate of burning its composition may be modified by dilution with, for example, starch, lactose, resins, *etc* or, perhaps, with a proportion of the composition to be ignited. A much-used priming composition is SR 252, a mixture of sulphurless gunpowder with silicon powder and additional potassium nitrate; this gives a hot fusible silicate slag and is almost as ignitable as gunpowder itself. Tetranitrocarbazole is sometimes used in similar compositions as a replacement for the (moisture-absorbent) charcoal of gunpowder.
52. The organic material/oxidant compositions (for example, SR 214, lactose/potassium nitrate, used to prime coloured smoke compositions) burn more slowly than gunpowder and usually generate less heat.
53. The 'gasless' slag-forming priming compositions, apart from being invaluable for the ignition of the more inert slow-burning compositions, are also of great importance as primers for use at high altitudes because, since they give rise to little or no gaseous products, their own combustion is unaffected by the reduced ambient pressure. The fuels used in these compositions include boron, silicon, zirconium and its alloy with nickel, aluminium and magnesium. The oxidants may be chosen from the nitrates of potassium and barium, potassium perchlorate, barium chromate, and the oxides of barium, bismuth, lead, iron and molybdenum. Mixtures of silicon and 'red lead' ( $Pb_3O_4$ ) or bismuth oxide ignite readily from flashes and sparks and burn very fiercely; they are, however, very sensitive to friction. Mixtures of boron with bismuth oxide, barium chromate or potassium nitrate are now used almost exclusively for priming compositions to function at reduced atmospheric pressures in which they ignite readily and burn vigorously without explosive violence. A composition used for igniting tracking flares on missiles at high altitude is SR 399, a stoichiometric mixture of magnesium powder and barium peroxide.

#### *Delay composition*

54. A special example of a flame and heat-producing composition is the pyrotechnic 'delay' composition which is employed to produce a time interval between two igniting or explosive events. In its simplest (and least accurate) form it consists of a length of slowmatch, quickmatch or safety fuze; in its most sophisticated form it is an integral part of a delay-motor (in which, at the end of combustion, mechanical work is done either on a moveable piston or on an invertible diaphragm) operating with great accuracy over a wide range of conditions within a ballistic missile. All accurate pyrotechnic delays are trains of composition which burn in cigarette fashion from one end to the other. The train may be contained in straight or spiral tubes or in circular or S-shaped channels cut in metal or plastic plates. It may have to burn, vented or unvented, under extreme conditions of ambient temperature and pressure, acceleration, deceleration and spin. Its time of burning may be as short as a few milliseconds (in detonator delays) or may last for several minutes. For many applications its time of burning may not vary from the mean by more than a few per cent of its nominal value over the whole range of operating conditions.

55. Obviously the chemical nature, purity and physical form of the ingredients of delay compositions together with the uniformity of their blending must be closely controlled. Like the priming compositions, delay compositions may be gas-producing or gasless. Gas-producing compositions are almost invariably mixtures of carbonaceous fuels (some of which are nitrated and so contain a proportion of oxygen for combustion, for example, tetranitrocarbazole, nitroindene polymer, and tetranitro-oxanilide) and inorganic oxidants. The gasless compositions frequently depend on thermite-type reactions in which a metal powder and a metallic oxide interact in an oxidation-reduction reaction with evolution of much heat and formation of solid products; these may be fast burning, and short columns of such compositions are frequently used as alternatives to lead dinitroresorcinate or barium styphnate, see Chapter 9, or potassium dinitrophenate to produce suitable delays in detonators.

56. Intimate contact between metal and oxidizing agent is much improved by co-precipitation of the latter in appropriate instances with finely-divided metal (Chapter 9); this technique has been applied not only to the salts of nitrophenols but to oxides and oxidizing salts (for example, barium chromate). Barium chromate/metal compositions are relatively slow-burning, depending on the metal; zirconium burns faster than boron, which is faster burning than zirconium/nickel alloy, which in turn is faster burning than tungsten (the two last require the use of some potassium perchlorate with the barium chromate).

57. The relation between the rate of burning (sec/in) of a composition and the ambient pressure (atmospheres) is expressed by

$$R_1 = RP^n \quad \text{--- --- --- (4)}$$

where  $R_1$  is the rate at 1 atmosphere and  $R$  is the rate at  $P$  atmospheres, while  $n$  is a fractional index which depends on the nature of the composition and is greater the more the gas produced in combustion. For sulphurless gunpowder (a typical gas-producing delay composition)  $n$  equals 0.42; for the 'gasless' compositions  $n$  varies from 0.08 to 0.20.

58. Delay compositions burn faster as the temperature increases, but the change in the rate of burning of a gasless composition is greater than that of a gas-producing composition for a given change in temperature.

#### *Incendiary materials*

59. As was remarked in Chapter 2, incendiary materials have a history in warfare. Though not strictly 'explosives' some note must be taken of modern incendiaries as a special branch of pyrotechnics.

60. When combustible materials are heated their moisture-content is first driven off, followed by combustible gases arising from the chemical decomposition of the materials; as these gases burn, their 'back-radiation' may, under favourable conditions, help to support further decomposition. The flame temperatures of the burning gases and the thermal conductivities of the combustible materials lie within relatively narrow limits, so that the materials evolve gas at a rate mainly determined by their effective surfaces which receive heat from the source of ignition and from 'back-radiation'. Surfaces which have been dried out and heated to the point of evolving gases will 'flash over' into ignition. Clearly then, the source of ignition (the incendiary) must have a high heat of reaction. It is also obvious that this heat must be applied until the ignition temperature is reached and that therefore it must not be liberated too rapidly; in practice it is found that it should be four times the minimum heat for ignition.

61. In general, incendiary materials fall into two distinct groups. The first group is composed of metals and alloys which burn in air with a high heat of combustion and tend to concentrate their heat in a small area and the second is of combustible fluids which spread over the target while burning. Typical materials with their heats of combustion are:

	cal/g
Aluminium	7 000
Magnesium	6 000
Thermite	790
Potassium	1 240
Sodium	2 170
Phosphorus	5 900
Carbon disulphide	3 250
Turpentine	10 830
Napthalene	9 168
Hydrocarbons and their Gels (for example, Napalm)	10 000 to 11 000

62. Few incendiary materials are spontaneously flammable in air: the exceptions are (white) phosphorus, potassium and alloys of potassium and sodium, and certain metal alkyls, for example, aluminium triethyl and zinc diethyl; the remainder need to be heated to their ignition temperatures by pyrotechnic means. Liquid alloys of sodium and potassium are effective incendiaries but require special precautions in handling. White phosphorus dissolved in carbon disulphide is more effective than phosphorus in mass. The metal alkyls burn too rapidly to be effective.

63. Liquid fillings are ignited and scattered over the target by explosive charges, and are rendered more effective if they are 'gelled'. The hydrocarbons are gelled by addition of aluminium soaps (oleate or laurate), perspex or rubber. Typical compositions of this type (used in the Second World War) are:

SR 400	Benzene	95 parts by weight
	Rubber	5 .. ..
SR 425	SR 400	50 .. ..
	Aluminium powder	10 .. ..
	Calcium silicide	10 .. ..
	Sodium nitrate	27 .. ..
	Boric acid	3 .. ..

64. The two metals most useful as incendiary agents are aluminium and magnesium, which combine high heats of combustion with reasonably low melting points. They cannot well be used as powders because, if ignited by a small explosive charge, they tend to be dispersed and burn explosively as a dust-cloud in air. Their ignition in massive form is effected by Thermite (23.7% Al: 76.3% Fe<sub>3</sub>O<sub>4</sub>), the ignitability of which has been improved by mixing it with a proportion of barium nitrate (in SR 306) or barium peroxide.

RESTRICTED

65. For incendiary bullets and cannon-shell compositions, SR 365 and 379 are standard fillings.

SR 365	Magnesium-aluminium alloy (50/50)	50	parts	by	weight
	Barium-nitrate, size 120	50	..	..	..
SR 379	Magnesium-aluminium alloy (50/50)	47	..	..	..
	Barium-nitrate, size 120	50	..	..	..
	Paraffin wax	3	..	..	..

## CHAPTER 11

## Non-metallic materials

## CONTENTS

	<i>Para</i>
<b>Polymers</b>	1
<i>Non-metallic material specifications</i>	1
<i>Types and properties of polymers</i>	3
<b>Compatibility</b>	18
<i>Preliminary tests</i>	18
<i>Effect of temperature</i>	21
<i>Effect of sunlight, fungi, termites</i>	22
<b>Principal classes of non-metallic materials</b>	23
<i>Natural fibres (cellulose, silk, wood)</i>	24
<i>Rubber and synthetic rubbers</i>	27
<i>Plastics materials</i>	31
<i>Combustible cartridge cases</i>	42
<i>Paints and varnishes</i>	47
<i>Adhesives, cements and lutings</i>	53

## Illustrations

<i>Fig</i>		<i>Page</i>
1	Addition polymers	3
2	Condensation polymers	3
3	Removing combustible-cartridge case from former	10
4	Example of combustible-cartridge case	11

CHAPTER 11

Non-metallic materials

Polymers

Non-metallic material specifications

1. There is, of course, a wide and growing range of non-metallic materials, many of which have been employed in Service in the past and for which Service specifications exist. (Such specifications are currently being redrafted as Defence Standards, where no suitable British Standards exist, and those which apply to materials compatible with at least some explosives have the phrase 'Type X' followed by the name of the material. The Directorate of Quality Assurance, Materials, should be consulted to ascertain the current position regarding specifications.)

2. Designers should use specified materials whenever possible, but it must be remembered that their previous use may be quite irrelevant to new applications, and a careful check should be made of their suitability. If a new material must be employed, not only must its chemical and physical properties be assessed in relation to its intended use but an approved specification to govern its manufacture and properties must exist before its use can be finally approved. Many materials which are acceptable for use in the commercial world will not withstand the wide range of Service conditions, or will not do so for a sufficiently long time, and a sceptical approach to them is important — especially so when regard is given to the potentially disastrous consequences of a wrong choice of a material to be used in an explosive store.

Types and properties of polymers

3. All the non-metallic materials which are employed in contact with or in proximity to explosives are polymers (for example, cellulosic products, wool, felts, silk) or are based on polymers (for example, plastics, rubbers, adhesives, varnishes, cements, lutings). Polymers, whether natural or synthetic, are large molecules ('macromolecules') formed by either the 'addition' to one another of smaller (unsaturated) molecules or the 'condensation' (frequently with elimination of a by-product, often water) of one or two (or more) types of smaller molecule. Examples are given in Fig. 1 of addition polymers and in Fig. 2 of condensation polymers.

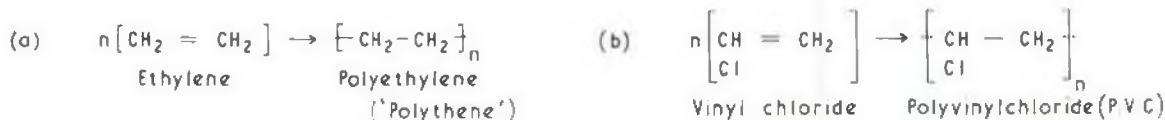

Fig. 1 Addition polymers

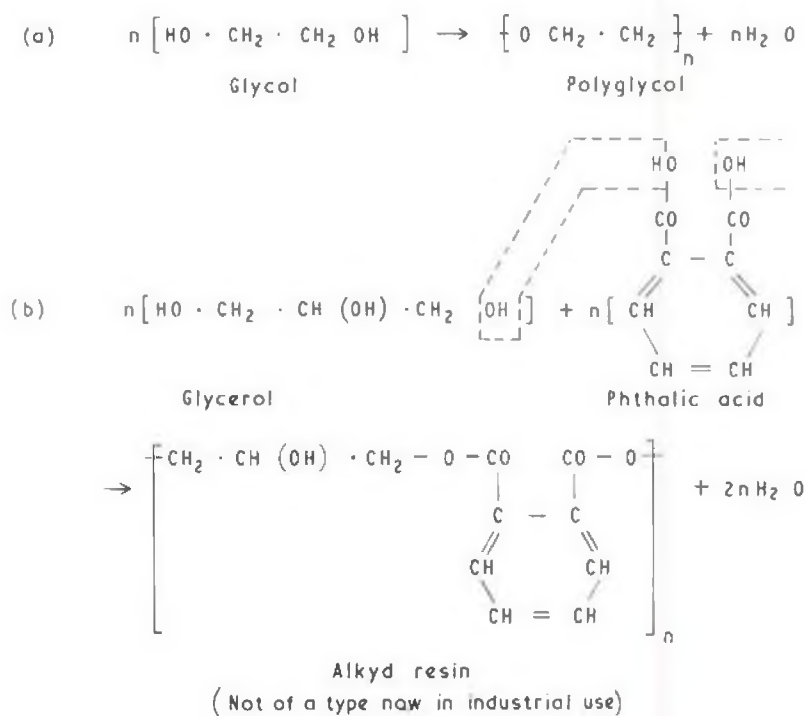

Fig. 2 Condensation polymers

4. The representation in Fig. 1 and Fig. 2 of the polymers in linear form in the plane of the paper is imposed by the textual method of communication of information. In fact, the molecules have structure in three dimensions because a carbon atom (unless subjected to some constraints) has its four valency bonds symmetrically disposed in space so that the angle between any two of them is about  $110^\circ$ . Thus polyethylene (at least, the earlier low-density type) is, in fact, an aggregation of  $-\text{CH}_2-$  chains randomly kinked in space and intermeshed with one another. In a similar manner, polyethylene glycol may be a viscous liquid or, as the size of the polymer molecule increases, waxy solid, due to the increasing length and intermeshing of the molecules. The alkyl resin, however, is a hard, brittle, solid; the reason for this is that the reaction between glycerol and phthalic acid is not completely represented by the scheme above; some at least of the hydroxyl groups in the middle of the glycerol molecules may react with carboxyl groups of phthalic acid molecules, giving 'cross-linkages' between chains of the type shown in Fig. 2(b) and so forming a 'box'-like molecular structure conferring rigidity on the product. There are other ways of cross-linking polyesters; one much-used method is to employ unsaturated dibasic acids, for example, maleic acid,  $\text{HO}-\text{OC}-\text{OH}:\text{CH}=\text{CO}-\text{OH}$ , usually used in the form of its anhydride; the double bonds constitute reactive points for attaching suitable cross-linking molecules. If, in some polymerization reactions, arrangements can be made to permit the formation of cross-linkages whilst limiting their number to a small proportion, the product may have rubbery properties (for example, polyurethane rubbers — see Chapter 8).

5. Besides the chemical valency forces which exist in the macromolecular structure of a polymer there are physical attractive forces, the so-called van der Waals forces, which are exerted mutually by molecular chains in close proximity. These forces increase the more closely the molecules are packed, and thus the material may assume a degree of crystallinity, especially if the chemical groups pendant to the main polymer 'backbone' chain are not bulky. Thus polyethylene is crystalline to the extent of 60% to 90%, due to the simple spatial arrangements of the polymer chains allowing a good 'fit' between the chains, although the intermolecular forces are relatively weak. Crystalline regions impart stiffness and hardness to a polymer (but may reduce its toughness) and generally extend the temperature range over which the polymer shows useful properties. Close 'packing' of the macromolecules occurs in certain recently developed 'stereo-specific' polymers, in which the addition-polymerization reaction is conducted under conditions which cause side-groups appended to the reacting molecules to 'line up' in a regular manner in the polymer molecule instead of being randomly directed in space. But the strength of the attractive forces is also dependent on the chemical nature of the atoms constituting the basic polymer network, so that the physical properties of a polymer can, to some degree, be 'designed' into its structure.

6. When a mass of a polymer consisting of randomly kinked molecules held together by van der Waals forces is pulled, the molecular chains tend to straighten out (the more so when cross-linkages are few) and extension of the mass occurs. If the applied extensive force is relaxed fairly soon the mass of polymer may in time resume its original dimensions, the molecular chains kinking and randomizing afresh under the influence of the 'thermal agitation' which is operative to some extent in all matter. If, however, the applied stress is sufficiently high or applied for a long enough time the molecular chains may slip, or 'flow', relative to one another, and a permanent deformation will result. This is, of course, facilitated if the temperature of the polymer mass is raised, thus increasing the thermal agitation of the molecules and reducing the cohesive effect of the van der Waals forces; thus filaments of nylon, 'Terylene' and polypropylene are drawn, under tension, from the respective polymers to straighten and slip the chains to yield orientated fibres of high tensile strength. In this condition the fibres are relatively resistant to the effect of solvents, due to their high degree of crystallinity; they are thus less readily affected by propellants containing nitroglycerine and other plasticizers.

7. In addition to the influence of heat in reducing the cohesive effect of the van der Waals forces, solvent molecules may penetrate polymer random structures and so weaken the cohesive forces as to result in mobile solutions being formed, but in smaller amount will render the polymer mass more flexible. If suitable non-volatile solvents are chosen, polymers which would otherwise have unattractive physical properties may be 'plasticized' to yield more useful products. Thus, nitrocellulose was plasticized with camphor to give celluloid, while the more or less hard, waxy, polyethylenes may be plasticized with polyisobutylenes of low molecular weight to yield products of industrial value, and the normally hard, rigid, polyvinyl chloride may be plasticized with as much as 35% to 50% of (commonly) dioctyl phthalate to yield a flexible product.

8. It must also be remarked that solvents and temperature changes may have less controlled (and undesirable) effects in some instances. Articles made from 'thermoplastic' polymers (see para. 32) may be in a state of stress and, if subjected to even the vapours of some solvents or to environmental changes, may crack; similar cracking may occur with other polymers in a state of stress, for example, natural rubber exposed to ozone.

9. Of course, some polymers may be so heavily cross-linked as to be not only hard and rigid but virtually insoluble — or even totally insoluble if the polymerization reaction has been taken so far as to build up very large macromolecules. Thus a range of phenol-formaldehyde polymers can be made, some of

which are soluble enough to enable lacquers to be formed and others of which are resistant to almost all solvents, and so incapable of any degree of plasticization; this is put to commercial use when a soluble form is used to produce, for example a phenolic moulding material which is converted chemically to the insoluble form during the moulding operation.

10. Besides plasticizers, industrial polymer products may also contain 'fillers', antioxidants, stabilizers, dyestuffs and pigments. The fillers and pigments will modify the physical properties of the finished material; they are often used also for economic reasons, usually being cheaper than the polymer or plasticizer.

11. Setting aside the naturally occurring polymers, it will be clear that a very wide range of synthetic polymeric substances can be made, either by addition reactions between unsaturated molecules (usually those containing the  $>C = C<$  system) or other molecules (for example, epoxides) or by condensation reactions between polyfunctional (most commonly bifunctional) molecules. Sometimes the primary molecules employed have been chosen because of their almost unique properties; thus, the marked resistance to oxidation of tetrafluoroethylene,  $CF_2 = CF_2$ , seemed to hold out promise that the polymer,  $(CF_2 - CF_2)_n$ , would be chemically inert, and this promise is realised in PTFE (Trade names 'Fluon' and 'Teflon'). But it is common to take into account the chemical properties of the primary molecules in selecting them for polymer syntheses so as to obtain polymers having certain desired properties; thus, the polymerization of molecules containing certain phosphorus and nitrogen groupings led to the formation of products which would withstand temperatures of the order of  $400^\circ C$ , but which were, unfortunately, too intractable to be useful.

12. The physical properties of polymers may range from those of viscous liquids to those of waxes, rubbers and rigid solids, and are dependent on the chemical nature of the primary molecules and on the degree to which the polymerization reaction has been taken. The chemical properties of the polymers will often bear some resemblance to those of the primary molecules, and this resemblance may be very close in the end-groups of polymer chains, where there may be unreacted double bonds, or carboxyl-, hydroxyl-, amino-, *etc.* groups, the importance of which, however, becomes relatively less as the molecular weight of the polymer increases. Some condensation polymers may be susceptible to attack by water (sometimes at the points of condensation in the molecular chain) if kept at high temperatures under conditions of high relative humidity, and this attack may be accelerated if the pH is markedly displaced from the neutral point. Such hydrolytic attack will lead to molecular degradation (that is reduction in chain length) with consequent loss of physical properties. Of course, reagents more active than water will often readily attack condensation polymers and sometimes, addition polymers. The ultraviolet content of sunlight is the most common agent of degradation under outdoor conditions, and atmospheric oxygen, especially if assisted by heat and/or moisture, may also cause degradation. The application of heat, with or without the presence of oxygen, will almost invariably break up a polymer, yielding fragments which can be recognized by modern analytical methods so that the nature of the polymer can be deduced; such thermal degradation may be progressive, yielding smaller fragments as the temperature is raised. It is to guard against these various forms of degradative attack that stabilizers are added to polymer compositions.

13. A consideration of the chemical properties of synthetic polymers must also take account of the fact that the commercial product may contain an excess of one of the reactant chemicals or residual quantities of a reagent employed to promote the polymerization reaction (for example, ammonia in some phenolformaldehyde resins) or to 'expand' the polymer (for example, light hydrocarbons in 'foamed' polystyrene, and even more reactive substances in some other instances).

14. Although most of what has been said about polymers relates primarily to those materials in which the large molecule is based on a structure of carbon atoms (sometimes with oxygen or nitrogen atom linkages), it must not be forgotten that other multivalent atoms can enter into polymer structures. A notable instance is silicon, which enters into the structure of the silicones — which frequently retain good physical properties at both high and low temperatures. When sulphur replaces oxygen in some polymer systems polymers of a rubbery character may result; some of these are the 'Thiokol' rubbers which were used in some American composite propellants.

15. It is hoped that from the foregoing remarks something can be inferred of the reasons for that 'sceptical approach' to the use of non-metallic materials which was recommended earlier in para. 2. Even if the basic polymer (or polymers) on which such a material is based is known to be capable of withstanding the full range of Service climatic conditions without loss of properties, the material itself is rarely free from other ingredients which may modify that capability. Similarly, even if it is known that the polymer has no adverse effect on a given explosive and that the explosive has no adverse effects on the polymer (both matters for investigation over the whole environmental range), it cannot be inferred that the industrial product under consideration and the given explosive will be mutually non-reactive. Just as the forms of 'rubber' in general use are not merely natural rubber, and account must be taken of what else is in them, so what may be described as a 'polyvinyl chloride plastic' or an 'acrylonitrile-

butadiene rubber' (nitrile rubber) or a 'cellulose acetate plastic' will almost surely contain other substances, the nature of which must be known before it is possible to make even a preliminary assessment of the suitability of the material for use with a given explosive; and if such a material is approved for its proposed use, that approval relates to the material 'as tested', and may be rendered void by any subsequent change in the composition and does not apply to any other use.

16. Finally, attention must be drawn again to the property of many polymers that, under stress, their molecular chains are capable of 'flow' relative to one another, so that under maintained stress the material may distort permanently — a consideration sometimes overlooked in the selection of polymer-based materials. It should also be noted that such stress-induced flow may be accelerated by the migration into the polymer of NG and plasticizers from propellants.

17. It is not profitable to attempt here to tabulate the physical properties of polymer-based materials which may be met with in commerce; they may change with changes in the formulation of the material. If some knowledge of such properties is required it is desirable to consult current editions of 'Modern Plastics Encyclopaedia' or 'British Plastics Yearbook' (see Bibliography) and to discuss the problem with an appropriate authority (for example, ERDE or DQA (Mats.)).

### Compatibility

#### *Preliminary tests*

18. It has been remarked in preceding paragraphs that the mutual compatibility of an explosive substance and a non-metallic material must be ascertained over the whole range of Service environmental conditions. Before time-consuming trials to that end are embarked on it is desirable to conduct some other tests involving only small quantities of the explosive and material. (See also Chapters 14 and 15.) In the first place the possibility of adverse effects on the sensitiveness of the explosive should be considered and unless it is quite obvious that the possibility can be ruled out, appropriate tests of impact and friction sensitiveness and, if necessary, of electrostatic properties should be made on combinations of explosive and material. The presence in the material of a hard abrasive filler may, obviously, show up at this point; but so also may the presence of some reactive chemical (for example, a lead 'soap' stabilizer or a reactive antioxidant).\*

19. If the results of these tests can be accepted, either as showing no adverse effects or as showing only modest increase in sensitiveness which may not be significant in practice (for example, because the intended use will not involve intimate admixture), tests involving the effects of heat on the mixture should be commenced as follows:

- (1) tests should be made to establish that the ignition temperature of the explosive is not lowered to a dangerous extent by mixing with the test material
- (2) the vacuum stability test (or, if the explosive is a single or double-base propellant, the silvered-vessel test, together with measurements of the rate of consumption of stabilizer) should be done on mixture and explosive.

Appropriate small-scale tests must be devised for initiatory, pyrotechnic and composite propellant compositions according to their chemical nature.

20. If the preceding tests and other critical small-scale tests show no serious adverse effects on the explosive, the larger-scale tests, involving the exposure of the explosive in contact with finely divided and massive portions of the material to the prolonged effects of heat (in the presence of moisture as well as in the dry state) as well as to the effects of refrigeration, may be undertaken. These tests will cover the extremes of Service climatic conditions; and at their conclusion each mixed sample will be examined for the appearance of acidity (or, sometimes, alkalinity), the explosive will be studied for changes in its chemical (and, with propellants, physical) properties, and the massive pieces of the material will be subjected to physical tests (for example, for 'tensile' properties and for dimensional changes) which will reveal degradation. Parallel 'climatic storage' tests done on the explosive and on the material alone will afford valuable comparative information.

#### *Effect of temperature*

21. It may happen that exposure of the material alone to several months' heating at 49°C or 60°C will cause degradation, which may be accelerated by the presence of moisture; the presence of explosive may or may not enhance such adverse effects. Long-term exposure of the explosive to the material may result in either chemical or physical changes — chemical, by reason of slow reaction with one or other of the ingredients of the materials; physical, often by reason of the migration of one or other of the

\*Although the progressive disappearance from the Service of picric acid has rendered the former insistence on 'lead-free' materials (that is, material containing less than 0.03% lead) less important (apart from the field of plastic propellants containing ammonium picrate) it is nevertheless suspected that occasional abnormal sensitiveness of tetryl can be attributed to contamination with lead compounds.

ingredients (notably plasticizers) of the material (or, with double-base propellants, of NG or plasticizer from the propellant to the material). Again, the slow 'distillation' of a plasticizer into an initiatory or pyrotechnic explosive may 'deaden' it while a plasticizer may have a solvent effect on a high explosive (for example, tetryl or RDX) with adverse consequences to its stability.

*Effects of sunlight, fungi, termites*

22. Apart from the effects of temperature and humidity, however, account must also be taken of the effects on materials of intense sunlight and of fungi and termites which may be encountered in certain parts of the world. Answers to these questions may be obtained by 'field' trials at the Joint Tropical Research Unit in Queensland, operated jointly by the UK Ministry of Defence and the Australian Department of Defence; they cannot easily be resolved purely by laboratory studies. Helpful information may be available from previous trials carried out at the Unit, and for information, contact should be made with the Unit's Liaison Officer in the Explosives Research and Development Establishment, Waltham Abbey.

**Principal classes of non-metallic materials**

23. A few notes will now be given in the following paragraphs on some of the principal classes of materials which are or have been used in contact with or in proximity to explosives.

*Natural fibres (cellulose, silk, wool)*

24. *Cellulose*: As was noted in Chapter 6, cellulose is a polymeric substance consisting of chains of anhydroglucose units and found widely in vegetable matter. For practical purposes, cotton and wood celluloses are the only forms of consequence, the former being used principally as a fabric and the latter as paper. As such, cellulose may be considered harmless with explosives — apart from any enhancement of fire risk to which it may give rise — while it is itself unaffected by stable explosives or explosive compositions. Obviously, if the cellulosic material is treated with some other substances (for example, starch on cotton, or loading or glazing substances in paper) the position regarding effects on explosives must be reviewed. If the explosive is, or can become, acidic it may be expected that it will have a degradative effect on cellulose, as will exposure to hot wet conditions. Cotton fabrics have been used for bag charges of propellants, for exploder bags and (together with paper) in the sheathing of pyrotechnic stores.

25. *Silk* is essentially a protein structure containing 66% fibroin and 22% sericin; unlike wool, it contains no organically bound sulphur. It is a reasonably stable material in the absence of acid conditions. It has been used to tie bundles of cordite to form propellant charges and to make bags for loose propellant charges (for example, for breech-loading guns); it was preferred to cotton for these purposes because it did not leave residues in the gun which might re-ignite when the breech was opened — a problem now dealt with in other ways.

26. *Wool* also is a protein-based material, the principal constituent being keratin; there is, however, also a variable amount of cystine and some methionine, which results in the wool having a content of organically bound sulphur varying between 3% and 4%. The cystine constituent is not as resistant to hot wet conditions as the other components of the wool. Wool fabric known as 'shalloon' was used for gunpowder igniters, but the chief current use of wool is in the form of felt for distance pieces and for taking up tolerances in fillings. A serious disadvantage of wool is its capacity for water-absorption; it may take up as much as 11% of water from an atmosphere at 50% RH, 17% at 75% RH and 33% at 100% RH.

*Rubber and synthetic rubbers*

27. From the standpoint of explosives technology the synthetic rubbers may be divided into those which, like natural rubber, are hydrocarbons or near-hydrocarbons with only carbon-to-carbon structural linkages, and those which have important linkages depending on other elements or groups (for example, oxygen, sulphur, imido- or carbonyl-). In general, the purely carbon-to-carbon structures are the more chemically stable, and are therefore to be preferred for use with explosives. But, as has been remarked in para. 15, even these rubbers may contain residual unsaturation and thus be open to oxidative degradation; this phenomenon is well known with natural rubber. Thus it is usual to find in the finished rubbers in technical use antioxidants (that is, more or less strong and reactive reducing agents) or stabilizers (that is, absorbers of ultraviolet light). Again, the pure rubber may be too extensible and it will normally be necessary to introduce a small amount of cross-linking to modify this property; this is done in the process known as 'curing' — in the instance of natural rubber commonly by heating with a little sulphur or sulphur-bearing organic compound in presence of an 'accelerator', in some other rubbers by reacting the base rubber (or 'gum') with an organic peroxide. So, apart from fillers (for example, insoluble salts, pigments, carbon black) and plasticizers, there may be residues of reactive materials in the final rubber. If the rubbers have been expanded ('foam' rubbers) they may contain residues of carbonates, bicarbonates or nitrogen-releasing compounds incorporated into the

rubber-filler-plasticizer-curing agent matrix to give rise to gases when the matrix is heated. (The compounds used to produce cellular rubbers are known as 'blowing agents', and some of them may be of doubtful compatibility with explosives.)

28. In general, the results of climatic exposures — in both temperate and tropical regions — confirm that the more nearly the base rubber of a rubbery composition is a hydrocarbon the more resistant is the composition. Nitrile rubbers and systems embodying acrylates are less satisfactory, but hydrocarbon rubbers in which some hydrogen atoms have been replaced by chlorine (for example, chloroprene) or fluorine (for example, Viton) are usually fairly resistant to extreme climatic conditions. Broadly speaking, the resistance of rubbery compositions to explosives at 60°C (140°F) is in line with their climatic resistance; but it will be obvious that this issue may be much obscured by the nature of the many other substances which may be present in the composition. In general, it is found that TNT and propellants containing nitroglycerine (especially if ester-type plasticizers are also present) have the most marked effects on rubbers.

29. The polyether- and polyester-urethane rubbers are not usually climatically resistant. Some sulphur-containing rubbers ('Thiokols') and silicone rubbers are reasonably resistant to climatic exposure, and the physical properties of most silicone rubbers are little impaired at low temperatures.

30. From the standpoint of the explosives, so much depends on the nature of the other substances present in rubbery compositions that few generalizations can be stated. Every basic rubber polymer tends to be the progenitor of a legion of trade compositions, but it can be said that, on the whole, compositions based on rubbers other than those of carbon-to-carbon linkage, or perhaps of silicone type, are best avoided, and that even the 'optimum' compositions must be subjected to critical study before they are employed with or in proximity to explosives. Much information exists as to the compatibility of explosives with rubbers (and other plastics) in the Explosives Research and Development Establishment, whose advice should be sought regarding all proposed uses. Because the Service usage of rubbers is relatively small (at least in peacetime) it may be necessary in extreme instances, and in the absence of trade interest, to make suitable compositions in a Service Establishment.

#### *Plastics materials*

31. The term 'plastics' includes materials also called 'resins'. In plastics, as in rubbers, it is usual to find that the finished product contains substances other than the basic polymer, and the nature of those substances must be taken into account in considering the association of a plastics material with an explosive. The basic polymers are of two main types, 'thermoplastic' and 'thermosetting', both of which may be used in conjunction with fibrous materials (glass, asbestos, carbon fibre, etc) to give composite (or 'reinforced') plastics having some physical properties superior to those of the polymers themselves.

32. *Thermoplastics*: The thermoplastics soften on heating and re-harden on subsequent cooling. They may therefore be reshaped, although the permissible number of reshapings may be restricted in practice by other considerations (for example, that heat may degrade the polymer). Because of their heat-softening characteristics their upper temperature of use is restricted. The polymers are essentially macromolecular chains, with little or no cross-linking but having some 'secondary' valency forces. Their physical properties (which are, fundamentally, based on their chemical constitution, molecular configuration and molecular weight) may be modified by the use of plasticizers or by 'orientation' — a straightening out of the long, randomly kinked chains by drawing or rolling.

33. Cordite is a thermoplastic in which the properties of the base-polymer, nitrocellulose, have been modified by plasticization with nitroglycerine, carbamate, etc, and by some orientation caused by rolling and extrusion. Celluloid, used for containers for mortar secondary charges, is a nitrocellulose-based thermoplastic the properties of which are largely dependent on the nature and amount of plasticizer (usually 20%-25% of camphor), as well as on the molecular weight of the nitrocellulose used in its manufacture.

34. Plasticized cellulose acetate is much used as an 'inhibitor' for limiting the burning surfaces of cordite and cast double-base rocket motor charges. It can be applied by hot moulding, but is more usually stuck on, using cellulose acetate adhesives (gels of cellulose acetate in a suitable solvent). However, the cellulose acetate plastics are very prone to exchange plasticizer with the propellant, from which they absorb nitroglycerine. When the rocket charge is of fairly small diameter (for example, the 2-inch air/air rocket) the cellulose acetate inhibitor may, under conditions of tropical storage, absorb so much nitroglycerine as to be markedly softened; at the same time the loss of nitroglycerine from the propellant is such as to increase the burning time of the charge considerably. For this reason, ethyl cellulose (which absorbs nitroglycerine somewhat less) has been used as a replacement for cellulose acetate and, more recently, has itself been replaced in some instances by 'Hypalon', a chlorosulphonated polyethylene material or rubbery characteristics, for which, however, it is necessary to employ a carefully compounded adhesive.

35. There is an extensive range of thermoplastics based on monomers containing C = C double bonds. Subject to anything which may be said concerning the reactivity of any substituents attached to those

carbon atoms, such thermoplastics are generally capable of being used in contact with explosives, although embrittlement may occur in time; but they are often too hard for wide application, and if plasticized to render them workable the plasticizer may give trouble. Thus, polyvinyl chloride (PVC), (monomer,  $\text{CH}_2\text{:CHCl}$ ) has to be plasticized in order that it may be useful as an insulating material on electric leads; if such leads are in contact with, or even proximity to, cordite, the plasticizer used may absorb nitroglycerine and the plastic sheathing of the wire will soften and even 'flow', exposing the wire to corrosive influences. In fact, polyvinyl chloride is not *per se* an ideal substance to be in contact with explosives since it tends to liberate hydrochloric acid in presence of moisture, a problem which is dealt with in most commercial PVC compositions by adding lead 'soaps'; polyvinylidene chloride (monomer,  $\text{CH}_2\text{:CCl}_2$ ) is less prone to this objection. Polyacrylonitrile (monomer,  $\text{CH}_2\text{:CHCN}$ ) is not used directly in commercial plastics, but as a copolymer with some other unsaturated monomer; the fibrous copolymers have as yet found no Service use where they are in contact with explosives, while the nitrile rubbers are very absorbent of nitroglycerine. (Butyl rubber is to be preferred in presence of systems containing double-base propellants.) Polymethyl methacrylate ('Perspex'), (monomer,  $\text{CH}(\text{CH}_3)\text{:CHCOOCH}_3$ ) is not appropriate in contact with explosives because it is prone to hydrolysis (at the ester group) in hot, wet, acidic conditions; it is also attacked (plasticized) by nitroglycerine, because of its ester structure.

36. However, the purely hydrocarbon polymers based on monomers having  $\text{C} = \text{C}$  groups (for example polyethylene, polypropylene, polystyrene, polybutadiene), as well as those of a fully halogen substituted character (for example, polytetrafluoroethylene (PTFE), (monomer,  $\text{CF}_2\text{:CF}_2$ ), are wholly compatible with explosives, and this compatibility will be destroyed only by the choice of inappropriate plasticizers or fillers in any compositions based on them. When a plasticizer is not used, as generally occurs with polystyrene, the finished formed article may be in a state of stress and may be liable to crack, especially in the presence of a solvent (or even the vapour of a solvent, for example, acetone or benzene). PTFE is not readily plasticized, being insoluble in almost everything, and so is generally used only in massive form in parts either machined from the solid or sintered (PTFE coatings result from the sintering of very finely divided polymer sprayed onto the surface in aqueous emulsion). The polymer is stable up to about  $325^\circ\text{C}$  (and usable up to about  $250^\circ\text{C}$ ) and retains its physical properties down to about  $-75^\circ\text{C}$ ; at temperatures high enough to soften it some decomposition is liable to set in.

37. Nylon and Terylene in fabric form have not hitherto found application in contact with explosives, but Terylene in film form (Melinex) is very resistant to nitroglycerine and to acidity developed by nitric ester-type propellants on storage, due to the molecular orientation of the polymer developed during production of the film. Fibrous Terylene is employed as a reinforcement in certain cast HE compositions containing TNT.

38. *Thermosetting plastics*: These are usually initially thermoplastic but, when subjected to continued heat and pressure, cross-linking reactions occur which result in the finish product being rigid, insoluble and incapable of again being softened by heat. Familiar instances of these materials are the phenol/formaldehyde, urea/formaldehyde, melamine/formaldehyde, polyester and epoxy resins. Provided that any condensation catalysts used in the preparation of the polymer are unobjectionable and that suitable fillers have been chosen, such plastics, if fully cured, are generally acceptable for use with explosives, and are, for example, being developed for the casings of non-metallic land mines.

39. Laminated and fibre-filled thermosetting plastics are made by impregnating a fibrous mass (for example, paper, fabric or chopped-strand mat) with a partly-condensed viscous-liquid polymer or mixture of resin precursors (for example, epoxy resin and curing agent) and heat-curing the mass either under pressure (if volatile products such as water may be evolved) or at atmospheric pressure (used for systems such as epoxy resins, which cure without evolution of volatiles). Glass-fibre rocket-motor cases are wound from epoxy-coated fibre; they have physical properties (including expansion coefficients) comparable with those of steel cases, but are lighter.

40. *'Engineering' plastics*: The number of commercially-available plastics has been increased in recent years by the advent of the so-called 'engineering' plastics. These comprise, at the time of writing, polyacetals, polycarbonates, polyethylene terephthalate ('Terylene', in injection-mouldable form), poly-4-methylpentene-1 (sold as 'TPX'), polyimides, polyphenylene oxide, polyparaxylylenes and polysulphones; it is likely that their number will increase further. They are frequently more complex than their names imply; some are copolymers and others are blends with long-established polymers; polyimides and polyparaxylylenes can (like PTFE) be fabricated only by special techniques. They are generally characterized by higher chemical, mechanical and thermal endurance than the 'traditional' plastics. Thus, polyacetals show much less 'creep' under mechanical stress than, say, high-density polythene, while polysulphones are intermediate in thermal resistance between the nylons and PTFE. Most of them are available with fibrous reinforcement, which improves their mechanical performance. All are reasonably good electrical insulators, and can generally be moulded to finer tolerances than the more common plastics; they are therefore increasingly being used in small precision mechanisms (for example, detonators).

41. To realise the full potential of these materials strict attention must be paid to mould design and control of processing. Study of the explosives compatibility of these materials is generally undertaken at ERDE soon after their appearance on the market, and some have already been reported on while others are under test at the time of writing. In view of the sophistication of these polymers, and their relative novelty, it is extremely desirable that the advice of ERDE be sought on their use with explosives before design activity involving them is begun.

#### *Combustible cartridge cases*

42. It is logical at this stage to discuss a non-metallic materials development which has become important in recent years namely the combustible cartridge case (CCC).

43. The original argument for the development of the CCC turned on the cost and weight of the brass cartridge case for a gun. It was considered that it should be possible to devise a totally consumable cartridge case which (*ipso facto*) would not be a heavy item. Obviously, a principal ingredient of the structure of such a case could be nitrocellulose, and it could be imagined that a nitrocellulose felt could be shaped into a cartridge case. But if such a shaped felt were to have anything approaching adequate strength the length of the NC fibres must be considerable, and it was known that such fibres would not be chemically stable owing to retained acidity; moreover, such an all-nitrocellulose case might be expected to be too great a fire risk. For both of these reasons therefore it seemed that the approach must be to obtain a strong felt by the use of as much long-fibre cellulose as necessary and to obtain combustibility by the admixture therewith of the requisite proportion of stable (short-fibred) nitrocellulose. In practice, it was found necessary also to incorporate into the felt a proportion of a thermoplastic to contribute additional strength; a thermoplastic was appropriate because, in the early work in the USA, the (wet) shaped felt had to be dried under constraint in order to meet the requirements of dimensional precision. Even so, however, it has not proved easy to manufacture a CCC which is a satisfactory replacement for the self-obturing brass cartridge case, the rim of which is severely stressed in ramming. Accordingly, in the British Service, attention has been concentrated on the manufacture of CCC for guns using separated ammunition (for example, tank guns), and an outline of the process will now be given.

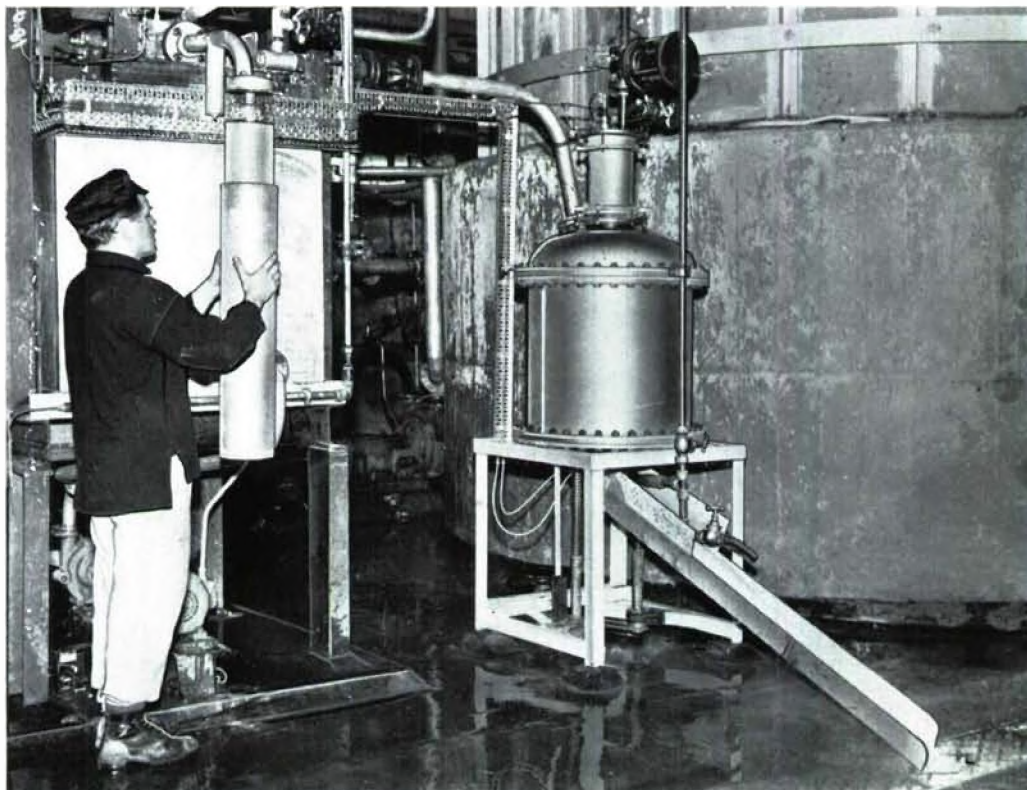

Fig. 3 Removing combustible cartridge case from former

44. In the first place, a 'kraft'-type wood pulp is dispersed in water, using a papermill-type beater in which the blades are set to do only a controlled minimum of chopping of the pulp fibres. One part (dry weight) of such pulp is then mixed with two parts of pyronitrocellulose (12.6% N) and a little carbamate

(stabilizer) in sufficient water to give a slurry containing 3% of solids. The pH of this slurry is then adjusted so that an aqueous latex dispersion containing 53% of a butadiene/styrene copolymer (total of 25% solids) can be added and stirred in thoroughly before a solution of a buffer salt is added to lower the pH and cause deposition of the copolymer on the fibres. The slurry is then diluted to 1% of solids before the felting operation is carried out. In this operation either a female- or a male- shaped former of fine wire gauze is used. If the former is male-shaped, it is dipped into a measured quantity of the slurry which may be sucked onto the former by application of a partial vacuum; if a female-type former is used the slurry is pressure-fed onto the gauze (Fig. 3). The felt 'preform' thus deposited is removed from the gauze by air pressure and partially dried at elevated temperature. The felt is next brought to a controlled moisture-content in a thermostatically controlled humidifying chamber before being pressed to size by an air-pressurized bag against a preheated (130°C) mould. At this stage a moulded screw-thread may be formed on the walls of the case at the open end to mesh with a threaded cap made by similar methods, or the walls may be left plain to take a cap stuck in with a suitable adhesive.

45. Such CCCs are thus an 'engineered' and improved container in substitution for the older 'bag charge'. They are waterproof, and have a strength of about 3500 lb/in<sup>2</sup> to 4000 lb/in<sup>2</sup> 24.1 MN/m<sup>2</sup> to 27.6 MN/m<sup>2</sup> and an ignition temperature of about 170°C, properties which are comparable with those of cordite. They are completely consumed in the gun (with reduced gun wear as compared with bag charges), being themselves readily ignited by a separate small igniter and giving excellent overall ignition to the propellant charge contained in them. As far as they have gone, storage trials of charges in CCCs indicate a degree of ballistic stability superior to that of bag charges.

46. The cost of materials for such CCCs is, of course, very competitive with that of the corresponding amount of brass, but it is too early to estimate the total cost of cases produced by the procedure outlined above, the 'industrialization' of which is still in hand. An example of a combustible cartridge case is given in Fig. 4.

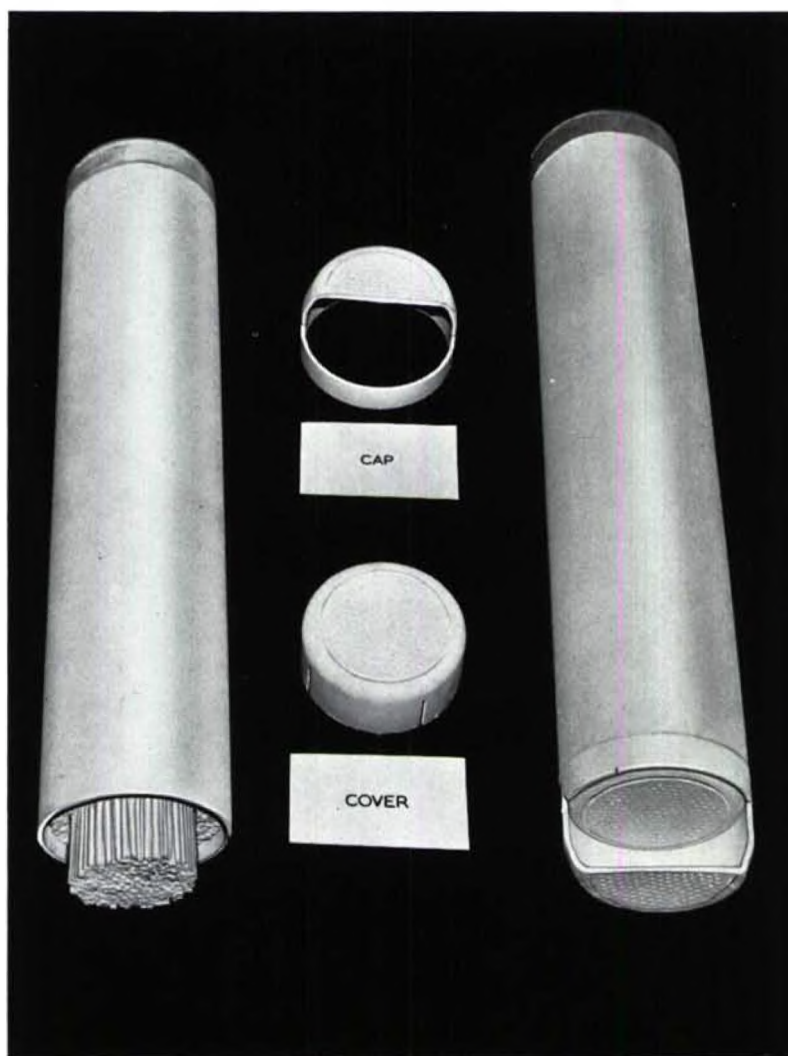

Fig. 4 Example of combustible cartridge case

*Paints and varnishes*

47. To the extent that paints and varnishes are compounded to protect surfaces primarily from moisture and other natural agents of attack they are not of interest from the standpoint of compatibility with explosives, since it will be only by accident that such materials come into contact with explosives, for example, if spillage occurs during the filling of shell the outer surfaces of which have been prepainted, or if TNT exudes from a shell in storage and contaminates the painted surface (from which it can easily be removed with a rag soaked in solvent naphtha, white spirit, toluene or xylene before the much more serious job is tackled of opening up the shell for emptying). But there are one or two varnishes which have been designed for use on surfaces which would otherwise necessarily be in contact with explosives, and which must be mentioned here.

48. The introduction of the amatols made it necessary to adopt a protective varnish for the inside of shells and bombs to resist the corrosive effect of ammonium nitrate, and copal varnish was chosen for this purpose. It consisted of gum copal, linseed oil and thinners and 'driers' (metal salts of organic acids which catalyze the hardening (cure) of linseed oil).

49. Similarly, there was a need to protect the interior of brass cartridge cases from the nitrous oxides arising from the degradation of cordite, or from the traces of ammonia which might be formed in picrite cordite on storage, and this requirement was met by shellac varnish. Several grades of shellac varnish came into use for other explosives purposes (for example, as a sealant on the free surface of the primary explosive in caps and detonators; as an adhesive for paper used in pyrotechnic stores; as an alternative to copal varnish for certain large HE stores) but all are, basically, solutions of natural shellac resin in methylated spirit.

50. In the First and Second World Wars shellac and gum copal became scarce, and attention was given to lacquers based on phenol/formaldehyde resins. When the condensation of phenol with formaldehyde takes place in presence of an acidic promoter, and under carefully controlled conditions, the product has little or no cross-linking and is therefore readily soluble in a number of volatile organic solvents to constitute lacquers which may be applied to steel and brass surfaces. If the coated articles are subsequently stoved for half-an-hour at appropriate temperatures tenacious resin films are formed which are resistant to gunpowder, HEs and the vapours from propellants.

51. Similarly, 'cellulose ester varnishes' based on grades of 'soluble' nitrocellulose (N-content of 10% to 11%) were developed for use in the varnishing of certain detonators. One such varnish consists of 3% of nitrocellulose in a mixture of methylated spirit, butyl acetate and petroleum spirit, with 0.4% of dibutyl phthalate which gives a non-brittle film on drying. For situations in which there was any risk of development of acidity, with possible adverse consequences to the stability of a nitrocellulose-based varnish, a polystyrene/coumarone resin varnish was developed; this contained tritolyl phosphate (half the weight of the resins) as a film plasticizer.

52. Finally, a range of varnishes based on bitumen, plasticized with a small proportion of castor oil and thinned with solvent naphtha (or, if a 'non-flam' solvent was required, thinned with trichloroethylene), was developed both for coating iron and steel surfaces of HE stores and for 'cementing-in' cardboard closure caps and for 'anchoring' HE fillings in shell, *etc.* Although compatible with most explosives (but not those containing ammonium nitrate), these varnishes are slow-drying and great care is needed to ensure the complete removal of solvent, which may otherwise form mixtures with air remaining in large stores; such solvent/air mixtures may 'diesel' (with disastrous effects) if the solvent is flammable and the store is dropped violently onto a hard surface.

**Adhesives, cements and lutings***Sealing stores*

53. Although it will be apparent that rubbers and varnishes of known compatibility with explosives can be (and often are) used to seal closures of explosive stores, it is convenient at this point, before discussing other materials which may be so employed, to re-emphasize the importance of ensuring effective closure of such stores. Obviously the ingress of massive quantities of water (for example, from exposure to rain or from immersion in flood water) into many kinds of ammunition may render them useless or even dangerous. But it is not always recognized that the ingress of atmospheric water vapour must equally be guarded against and that, because the water molecule is the smallest commonly met with, such ingress can be prevented only by making joints 'vacuum-tight'. If a closed tank, fitted with a bottom run-off valve and a top inlet valve, is left out-of-doors during a warm day and a cool night, with the bottom valve closed and the top valve open, a surprising amount of water may be collected from it; as the air in the tank cools — and contracts — at night it deposits its moisture, while more air enters to deposit further moisture. All explosive stores have some degree of free space (which can be quite large in rocket motors, for example) and this free space can 'breathe' (like the tank) and collect water due to diurnal expansion and contraction effects unless it is totally sealed from the atmosphere.

54. Of course, 'faced' joints can be made between metal components which will be vacuum-tight, but such joints are too expensive for mass-produced munitions. Thus, apart from designing into the finished store the minimum number of external joints, it is necessary to choose for those joints the best possible sealing systems, in which the faces and threads to be sealed are so designed as to enable an adequate quantity of sealing material to be used and retained effectively, while the sealing material itself must be designed to meet stringent physical conditions as well as to be compatible with the explosive(s).

55. Factors controlling the choice of methods of sealing stores are discussed in some detail in the Explosives Research and Development Establishment publication 'A Manual of Sealing Compositions for Ammunition (Incorporating ERDE Report No. 27/R/55)'.

56. It is worth remarking that plastics foils should be regarded with suspicion as barriers to water vapour. If they are thin they may have 'pin-holes' (as may the thinner metal foils), and they will certainly be prone to accidental damage. But even plastics barriers of thicker type may, either because of their chemical structure or because of the nature of plasticizers used with them, be capable of allowing water molecules to diffuse through them; they may serve adequately for commercial purposes in temperate climates but be inadequate in hot-wet tropical regions. Hydrocarbon materials (rubbers, polyethylene, polypropylene, polystyrene, etc) are rather more suitable barriers for use in reasonably thin form, but the best results are obtained with polyolefine/aluminium foil laminates.

*Bonding surfaces*

57. When two surfaces are to be bonded the requirement may be for permanent or temporary adhesion. If the junction is to be permanent, adhesives or cements are used; if temporary, lutings (soft, non-setting, compositions) are employed. Accordingly, adhesives and cements will first be discussed and consideration of lutings will be deferred to para. 63, although it is recognized that some adhesives are less permanent than others.

58. The satisfactory bonding of surfaces by adhesives and cements depends on the adhesion of the bonding material to each surface separately, and on the 'internal' (cohesive) strength of the bonding material itself. The adherence to a surface depends on the presence between the adhesive or cement and the surface of at least van der Waals forces, and it is improved if chemical forces can also come into play. When the 'free' van der Waals forces are weakened owing to difficulties in 'wetting' the adherend (as occurs with polythene and PTFE, which are virtually insoluble in any solvent at normal temperatures), adhesion is very difficult to obtain.

59. Solvents, of course, 'free' the van der Waals forces of materials which they attack (and thus large cellulose acetate tubes, required for cast double-base propellant charges, are made by wetting with acetone the surface of a cellulose acetate foil while winding the foil onto a former), and their presence in some adhesives and cements may assist the adhesion of the latter to some surfaces (if only by rendering the polymer constituent mobile so that it may reach the substrate surface), apart from their use as dispersion media for the bonding material. But the presence of solvents in adhesives and cements has disadvantages. If the bonding material is to 'set' satisfactorily the solvent must be able to 'dry out', and if the material is used in excess solvent vapours may remain in enclosed spaces (and perhaps be deleterious to some part of a munition store), so that great care is needed in the use of solvated adhesives and cements. For these reasons there has been a growing interest in the 'chemical' adhesives, in which a bonding polymer is formed *in situ* by the interaction of reactive chemicals. An early type of such adhesive depended on the reaction of a dialdehyde with a diamine, with elimination of water. However, unless the components were mixed with careful regard to their stoichiometric proportions an excess of one of the reagents was present, and this was particularly objectionable in the instance of the diamines, which are much too basic to be allowed to come into contact with most explosives; moreover, the water produced in the 'setting up' reaction diffused out of the adhesive only very slowly. These systems were, therefore, not acceptable for explosive munitions.

60. The next advance in the field of 'chemical' adhesives (apart from the 'self setting cements' — see below) was the development of the epoxy-adhesives. There is an extensive chemistry behind these substances, but manufacturers are reticent about the precise details. Briefly, halogenated epoxy compounds (the most readily accessible of which is epichlorohydrin,  $\text{CH}_2 - \underset{\text{O}}{\text{C}} - \text{CH} - \text{CH}_2\text{Cl}$ , can be condensed with dihydroxy compounds (typified by  $\text{HO} \cdot \text{A} \cdot \text{OH}$ ) under alkaline conditions to yield chain-like polymers:

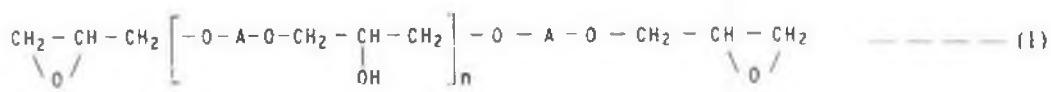

If  $n = 0$  to 1 the product is usually a viscous liquid (fractional values of  $n$ , used in the industry, refer to solutions of material of  $n = 1$  or more, the monomolecular product for which  $n = 0$ ). Products of this type may be 'cured' (that is, converted to thermoset resins) by reaction with any of well over fifty different classes of chemical compounds. In presence of tertiary amines ( $R_3N$ ) 'homopolymerization' occurs by reaction between the end epoxy groups, but reaction with compounds containing two or more reactive hydrogen atoms produces 'copolymers' in which the compound links together two polymer chains by itself reacting with their end epoxy groups; a similar reaction occurs with acid anhydride cross-linking agents. Thus an epoxy adhesive is the product of the *in situ* reaction of an epoxy chain-polymer and a cross-linking agent, and the chemical nature of the two ingredients may be known only to the manufacturer, who describes them merely as 'resin' and 'hardener'. However, so far as the British Service is concerned, certain epoxy adhesives made by CIBA (ARL) Ltd, and once characterized by the numbers 2000, 2500, 2700 and 2800, have been cleared for use with explosives, No. 2700 being the most generally compatible; all these are hot-setting cements, employing relatively innocuous hardeners. But even these adhesives must be mixed with strict attention to the accuracy of the proportions of ingredients used if full compatibility is to be achieved together with the very strong adhesion which should characterize the epoxy adhesives. The warm-setting, and even more the cold-setting, epoxy adhesives tend to be unacceptable from the standpoint of compatibility with explosives because of the reactive nature of the hardeners (often amines) which must be employed to cure them.

61. There is another, much older, class of chemically 'self-setting' cements, depending on the oxidative effect of lead oxide on glycerol (known in Service as Cements CD No. 2, RD 1200A and RD 1200B) and on boiled linseed oil (Cements RD 1193B and RD 1217A) to give rock-hard final products. They should not be used in proximity to HEs, for which another group of chemically setting cements was devised (Cements RD 1241B, 1242B, 1243B and 1248); these depend on the reaction of magnesium oxide with oleic acid in a copal resin varnish, and are slow setting. More recently these cements have been replaced by RD 1286, in which paraformaldehyde reacts with a polymer derived from cashew-nut shell.

62. The chemically setting cements are, of course, solventless. But there is a wide range of solvated cements, which may be regarded as more or less viscous solutions of natural or synthetic polymers, with or without fillers, and which are occasionally employed. These depend on the drying out of the solvent to leave the polymer — and fillers, if any — in the region between the surfaces to be bonded. The prime considerations in the choice of them (the first approach to which should be made with the aid of the ERDE Manual, see para. 55) are:

- (1) whether they will set under the conditions of use
- (2) their compatibility with the relevant explosive and
- (3) whether they have appropriate physical strength when set.

#### *Lutings*

63. Lutings, as was noted above, are used to seal joints which may need to be broken from time to time. The early ones (RD 1154, 1160, 1178, 1205A and 1251) were mostly based on bitumen and were made in a range of degrees of hardness; they depended for their non-setting property on the presence of an appreciable proportion of raw castor oil. Later lutings (RD 1284, 1284A, 1287 and 1287A) are based on the incorporation of waxes or polythene with polyisobutylene of low or medium molecular weight; they are chemically inert and have replaced the earlier materials, being used not only for joints but also as coatings for the internal surfaces of shell before filling.

## CHAPTER 12

## Propellant Charges

## CONTENTS

	<i>Para</i>
<b>General considerations</b>	1
<i>Responsibilities of explosives technologist</i>	1
<i>Burning laws</i>	2
<i>Calorimetric value of propellant</i>	4
<b>Internal-ballistics estimations for guns</b>	6
<i>Burning rate</i>	7
<i>Equation of state for internal ballistics</i>	10
<i>Geometrical-form coefficient</i>	14
<b>Quality control of propellants for guns</b>	18
<i>Principal characteristics inspected</i>	19
<i>Measurement of propellant force and vivacity</i>	20
<b>General characteristics of propellants for guns</b>	23
<b>Factors influencing design of rocket-motor solid charges</b>	28
<i>Combustion-chamber operating pressure</i>	28
<i>Rocket thrust</i>	30
<i>Gas relationships</i>	31
<i>Specific impulse</i>	34
<i>Rocket-motor stability</i>	37
<i>Platonization</i>	40
<i>Mesonization</i>	43
<i>Nature and properties required of propellant charge</i>	45

## APPENDIX A

## A simplified method for the calculation of the adiabatic flame temperature of gun propellants

## Tables

<i>No</i>		<i>Page</i>
1	Theoretical values of the form coefficient	6
A1	Additive constants of propellant compositions	16

## Illustrations

<i>Fig</i>		
1	Example of variation of burning rate with pressure for platonized CDB propellant	11
2	Example of burning rate curves for mesonized propellant	12

## CHAPTER 12

## Propellant Charges

**General considerations***Responsibilities of explosives technologist*

1. The ultimate responsibility for the design of a propellant charge must rest with the internal ballisticians, whether in the field of high-pressure systems (guns) or low-pressure systems (rockets or gas-operated mechanisms), but it is necessary for the propellants technologist to co-operate closely in the design (in order to ensure the feasibility of its production) and to appreciate the tests which must be applied to the propellant for quality control. The reliability of the propellant charge, as also of the propellant of which it is composed, is of vital importance to the safety and efficiency of the system in which it is employed.

*Burning laws*

2. As remarked earlier (Chapters 6 and 8), it was found possible to obtain ballistic regularity (that is, reliability) in the use of gunpowder by careful control of the size and geometrical form of pellets which had been so well compressed that they were not porous to the penetration of hot gases, which would have resulted in progressive increase of the rate of combustion and consequent loss of control. In fact, it was on the basis of the study of the burning of gunpowder that two fundamental laws (still generally applicable to propellants) were formulated:

(1) *Piobert's law* of burning by parallel layers (1839) — the surface of a burning propellant regresses, layer by layer, normal to the surface at every point (inhibition of a particular surface will of course prevent burning at that surface)

(2) *de Saint Robert's rule* (1862) connects the linear rate of burning,  $r$ , with ambient pressure,  $p$ , in the form

$$r = ap^{2/3} \quad \text{--- (1)}$$

where  $a$  is a constant. This was generalized by Vieille (1893) by the formula

$$r = ap^n \quad \text{--- (2)}$$

as a result of his work on the burning of colloidal (single base) propellants;  $a$  is known as the 'burning rate coefficient' and  $n$  as the 'pressure index' of the propellant.

3. If Vieille's law is written in logarithmic form

$$\log r = \log a + n \log p \quad \text{--- (3)}$$

it will be seen that a plot of  $\log r$  versus  $\log p$ , is a straight-line in which the 'slope' of the line is defined by  $n$ . (If  $n$  is greater than unity, combustion will proceed with an excessive rate of burning at any pressure.)  $\log a$ , a constant for a given propellant, is characteristic of that propellant. Thus, from measurements of the linear burning rate of a propellant at different known pressures the values of  $a$  and  $n$  can be deduced.

*Calorimetric value of propellant*

4. Apart from geometrical form and the values of the constants in Vieille's law, the other property of a propellant which would be expected to be of importance is its available energy content. This can be calculated by the application of the principles of thermochemistry to its composition and of thermodynamics to its (complex) combustion processes. But a more practical approach from the point of view of quality control is, usually, to determine its 'calorimetric' value, (sometimes termed 'heat of explosion'), that is, the heat evolved when it is burnt in a sealed pressure-vessel without the added oxygen which is employed when the 'calorific' value of coal is measured. This procedure results in a reasonable approximation to the final products of combustion which might arise under the conditions of use of the propellant, the precise composition of which products would effect the actual overall energy release in practice.\*

5. If the propellant in question is a simple single- or double-base composition (Chapter 8), the sole source of oxygen for the energetic combustion of the carbon and hydrogen in its constitution is that contained in the nitric ester groups,  $-\text{O}\cdot\text{NO}_2$ , the nitrogen in which will, for all practical purposes, end

\*If a combustible cartridge case (Chapter 11) is used it will be necessary to take its calorimetric contribution into account in computing the total energy of the overall propellant charge system.

up as molecular nitrogen. (Note: Oxygen which is already bonded to carbon in the molecules of ingredients of propellants contributes nothing to the energy of combustion.) Since this oxygen is insufficient for the complete oxidation of the carbon to CO<sub>2</sub> and of the hydrogen to H<sub>2</sub>O, the amounts of the gaseous products arising from the carbon and hydrogen are governed by the water-gas reaction



which involves little change in specific heats (one diatomic and one triatomic molecules on either side of the equilibrium) and no change in volume. Thus the volume of gases produced by the combustion, under calorimetric conditions, of unit weight of such a propellant will be independent of the exact nature of the gaseous products, as will the calorimetric value [inclusive of the heat liberated in the condensation of the water vapour, that is, 'calorimetric value (water liquid)'], see also Chapter 4. This relatively simple state of affairs is, anyhow, only approximately true even for such 'simple' propellants (the less energetic of which for instance may on combustion give rise to a proportion of methane which can have a significant effect on the measured calorimetric value); it cannot be assumed for double-bass propellants containing picrite, which gives rise to ammonia and some hydrogen cyanide when the propellant is burnt; it is still less true of the composite propellants.

**Internal ballistics estimations for guns**

6. Six parameters describing the propellant enter into the equations of the internal ballistics of a gun. One of these is the density of the solid propellant; two others are associated with its rate of burning. The three remaining parameters are thermodynamic properties associated with the products of combustion of the propellant, namely, the covolume, the force constant and the specific heat at constant volume of the gases.

*Burning rate*

7. Under the high pressure conditions prevailing in a gun (10 to 20 or even 30 ton/in<sup>2</sup>)\* the value of *n* in Vieille's law (equation 2) approaches unity (while the value of *a* is of the order of 1 to 2 in. per ton/in<sup>2</sup>); thus the law approximates to *r* = *ap*. However, Muraour showed that under gun conditions Vieille's law could be replaced by the relationship

$$r = A + Bp \quad \text{----- (5)}$$

where *A* and *B* are constants.

8. Muraour also showed that the rate of burning could be related to the heat of explosion or (better) to *T<sub>e</sub>*, the temperature of explosion, by the equation

$$\log r = 1.37 + 0.27 \frac{T_e}{1000} \quad \text{----- (6)}$$

*T<sub>e</sub>* can be calculated by a process of approximation applied to the thermochemistry of the propellant and of its combustion products ('Internal Ballistics', HMSO, 1951 — Chapter 2) or by a simpler method outlined in Appendix A to this Chapter.

9. Muraour also demonstrated that *r* is dependent on the starting temperature of the propellant and (in closed-bomb experiments) on the pressure, though not on the temperature, of the surrounding gas. Later work has shown, however, that the temperature of the gas layer immediately adjacent to a burning-propellant surface is a controlling factor for the rate of burning. There are thus two methods of determining *r*, one by pressure-time measurements in a closed vessel and the other by thermochemical calculation.

*Equation of state for internal ballistics*

10. In treating gaseous systems the usually employed equation of state is

$$pV = RT \quad \text{----- (7)}$$

where *p* is the pressure, *V* is the volume, *R* is the gas constant and *T* is the absolute temperature. However, this equation is true only for the so-called 'ideal' gases. In practice, gas molecules exert attractive forces on one another, resulting in the gas being more compressible than an ideal gas, and they occupy a finite volume. Accordingly, van der Waals proposed an equation of state

\* 1 ton/in<sup>2</sup> = 15.4443 MN/m<sup>2</sup>

$$\left(p + \frac{a}{V^2}\right)(V - b) = RT \quad \text{--- (8)}$$

in which  $a/V^2$  is a correction for molecular attraction and  $b$ , the covolume, is a correction for the finite volume occupied by the molecules. Under the high temperature conditions in a gun the correction for molecular attractive forces is immaterial, and so the equation of state used in interior ballistics is

$$p(V - b) = RT \quad \text{--- (9)}$$

for values of  $T$  less than  $T_n$  where  $T_n$  is the temperature of explosion. The equation assumes that  $b$  is independent of temperature, and theoretical considerations show that it should change by less than one per cent over the range 2000 K to 3000 K for a typical cordite. If  $RT$  is treated as a constant,  $k$ , equation 9 may be written

$$pV = k + bp \quad \text{--- (10)}$$

Equation 10 was enunciated in this form by Noble and Abel, who found that a graph of  $pV$  versus  $p$  is nearly a straight line.

11.  $b$ , the observed covolume, is about 1 ml/g, the whole range of covolumes for modern cordites extending only from 0.9 to 1.1 ml/g; the smaller covolumes are associated with the propellants of high explosion temperatures (calorimetric value about 1000 cal/g).

12. If it is assumed that the products of combustion of a propellant behave as ideal gases, and if cooling losses are ignored,  $p$ , the explosion pressure, is

$$p = RT_n/V \quad \text{--- (11)}$$

The quantity  $RT_n$ , which is equivalent to the constant  $k$  in the Nobel-Abel equation (equation 10), is the 'force constant', or just 'force', of the propellant. It is sometimes written as  $F$  and sometimes as  $\lambda_n$ ; the dimensions are those of energy per unit mass, and the unit convenient for gun calculations is (tons/in<sup>2</sup>)/(g/ml)\*. In these units the force of cordite SC is 70.52; thus when exploded at a density of loading of 0.2 g/ml the pressure to be expected is 14.1 tons/in<sup>2</sup>.

13. For ideal gases it can be shown by thermodynamics that the difference of the specific heat at constant pressure ( $C_p$ ) and constant volume ( $C_v$ ) is  $R$ ; that is,

$$C_p - C_v = R \quad \text{--- (12)}$$

The ratio of the specific heats,  $C_p/C_v$ , is usually written as  $\gamma$ . Thus

$$C_v = R/(\gamma - 1) \quad \text{--- (13)}$$

and it is, in fact, this term  $R/(\gamma - 1)$  which appears in the gun equations which, of course, do not refer to constant pressure or ideal gas conditions, so that in this instance the term  $\gamma$  has a special meaning and is not  $C_p/C_v$ . Now it has been shown experimentally that the temperature of the gases in a gun varies between  $T_n$  and a value approximately 0.6  $T_n$  (as the shot leaves the muzzle), and theoretically that  $C_v$  is equal to the difference between the internal energies of the gas complex at  $T_n$  and 0.6  $T_n$ , divided by 0.4  $T_n$ .

$$C_v = (E_{T_n} - E_{0.6 T_n})/0.4 T_n \quad \text{--- (14)}$$

These internal energies, which are the sum of the heat contents of the constituents of the gases at each temperature, can be calculated, and hence the value of  $\gamma$  derived. For conventional cordites this 'gun  $\gamma$ ' varies from about 1.22 to 1.28 the higher values being associated with 'cool' propellants (calorimetric value about 760 cal/g), which give rise to a higher proportion of carbon monoxide and hydrogen in the products of combustion than do the more energetic propellants.†

*Geometrical-form coefficient*

14. The effect of the geometrical form of the propellant is allowed for by a 'form' coefficient,  $\theta$ , defined by the 'form function'

$$Z = (1 - f)(1 + \theta f) \quad \text{--- (15)}$$

\* 1 ton/in<sup>2</sup> = 15.4443 MN/m<sup>2</sup>

† See Appendix 1 for a simplified method of calculating the flame temperature

where  $Z$  is the fraction of weight burnt at a given time ( $t$ ), and  $f$  is the fraction remaining at that time of the least thickness ( $D$ ) of the propellant. The truth of the foregoing relationship is evident for  $f = 0$  and  $f = 1$  since, clearly,  $Z = 0$  and  $f = 1$  and  $Z = 1$  when  $f = 0$ .  $\theta$  is a function of  $f$ , and is shown ('Internal Ballistics', Chapter 4) to have the values given in Table 1 for propellants of different shapes.

**Table 1**  
**Theoretical values of the form coefficient,  $\theta$**

Shape of Grain	Size ( $D$ )	$\theta$	Remarks
Long cord	Diameter	1	
Long tube	Wall thickness	0	
Long slotted tube	Wall thickness	$D^2/A$	$A =$ cross sectional area of tube
7-hole multi-tube	$1.15 \times$ web	$-0.172$	
Ribbon	Thickness	$1/k$	$kD =$ width of ribbon
Square flake	Thickness	$2/k$	$kD =$ side of square

15. The above values of  $\theta$  are, of course, based on the assumptions of simultaneous ignition of the whole grain surface and compliance with Piobert's law. Except for tubular shapes these values of  $\theta$  are generally to be satisfactory in practice.

16. The equation

$$Z = (1 - f) (1 + \theta f) \quad \text{--- (16)}$$

on differentiating and solving for  $f$ , yields

$$-df/dt = [(1 + \theta)^2 - 4\theta Z]^{-1/2} dZ/dt \quad \text{--- (17)}$$

Hence, by numerical differentiation of the calculated  $Z,t$  relation, corresponding values of  $df/dt$  and  $p$  can be deduced. However, this process is somewhat inaccurate, and a technique has been developed whereby the pressure is differentiated electrically to yield a record of  $dp/dt$  against  $p$  which may be used to determine  $df/dt$  directly, using known relationships between  $dp/dt$  and  $dZ/dt$  and between the latter and  $df/dt$ .

17. Charbonnier developed a theory of the burning of propellants, independent of Piobert's law, in which he postulated the relationship

$$dZ/dt = Qp^n \phi(Z) \quad \text{--- (18)}$$

where  $t$  is time,  $n$  is Vieille's pressure index,  $Q$  is the 'vivacity' or 'quickness' of the propellant and  $\phi(Z)$  is a form function defined by

$$V(Z) = \int_0^Z \frac{dZ}{\phi(Z)} \quad \text{--- (19)}$$

Now, from equation (18)

$$\int_0^t p^n dt = \frac{1}{Q} \int_0^Z \frac{dZ}{\phi(Z)} = \frac{V(Z)}{Q} \quad \text{--- (20)}$$

If  $p$  is plotted against  $t$  (both obtained from a series of measurements), a curve of  $p^n$  against  $t$  can be constructed and the integral  $\int_0^t p^n dt$  estimated. If this integral is plotted against  $Z$ , the slope of the curve at  $Z = 0$  has the value  $1/Q$ . Thus  $Q$  is obtained together with  $V(Z)$  as a numerical function of  $Z$ .

### Quality control of propellants for guns

18. It is now possible to summarize the approach to quality control of propellants for guns (it is assumed that the basically important step of 'blending' and 'lotting' has been taken — Chapter 8).

#### *Principal characteristics inspected*

19. The principal characteristics to be inspected are as follows:

- (1) the composition of the propellant including anticipated volatile matter at the time of use (it tends to vary in storage) must be checked for accuracy since the composition of the gaseous products of combustion is dependent on propellant composition and many internal ballistics calculations will be rendered more difficult if it is in error
- (2) the calorimetric value of the propellant should be measured (in a bomb calorimeter) when required although normally this is not required in routine inspection
- (3) the density of the propellant must be measured and checked against a control value
- (4) the shape and dimensions of the propellant are not normally checked but are verified by closed-vessel testing
- (5) the ballistic properties of the propellant must be assessed by experimental firings in a 'closed vessel', which is a vessel of robust construction (to withstand gun-type pressures) in which propellants can be burned under constant-volume conditions. From the point of view of the propellants chemist the object of these firings is to determine the rate of burning and vivacity of the propellant, while the ballisticians will use them to verify the calculated values of the force constant and the covolume of the propellant, and to check on the more doubtful values of  $\theta$ , the form coefficient. For inspection purposes, relative vivacity and relative force are measured (that is, values are relative to a standard lot of propellant).

#### *Measurement of propellant force and vivacity*

20. A description of the closed vessel is given in 'Internal Ballistics', Chapter 13 (HMSO 1951), and a detailed account of its operation is given in ARDE Memorandum (P)1/57\*. Basically, the vessel has a working volume of 700 ml and a working maximum pressure of 18 ton/in<sup>2</sup> (278 MN/m<sup>2</sup>). The normal propellant charge weight is 140 g (that is, charge density equals 0.2 g/ml), which gives a maximum pressure of 14 to 17.5 ton/in<sup>2</sup> (216 to 270 MN/m<sup>2</sup>) depending on the composition of the propellant. The vessel is fitted with firing electrodes [across which is connected a fuze wire threaded through a cambric bag containing 20 grains (1.296 g) of gunpowder], a valve for the release of pressure and a tourmaline crystal piezo-electric pressure gauge. The vessel is mounted in a water jacket to control its temperature; the propellant charge is preconditioned to a defined similar temperature (a variation of 10°F, about 5½°C, may cause a change of rate of burning of as much as 2%). The tourmaline gauge, which gives an electrical output related to the applied pressure, is connected to an electronic recorder designed to give a graph of  $dp/dt$  against  $p$ , whence  $p_{max}$  can be obtained.

21. For the comparison of two lots of a similar propellant, the relative values of  $p_{max}$  give the relative force whilst the relative values of  $(dp/dt)/p_{max}$  give the relative vivacity. Thus, if one of the propellants is a 'standard' the basic properties of the second propellant can be assessed and, in particular, the effectiveness of its blending as a propellant 'lot' can be judged — so saving a large part of the cost of what might otherwise be an extensive series of gun firings. It is, in fact, helpful to use a comparison propellant for another reason, namely that the considerable cooling corrections which arise in a closed vessel measurement 'cancel out'.

22. While closed vessel results should provide all the information required by the ballisticians or user of the propellant, it must not be forgotten that the sample used in the closed-vessel firing is small. The sample cannot give a fully reliable check on a 'lot' of propellant which may contain several tons of material unless the 'in process' inspection on the propellant has been carried out very thoroughly, with frequent measurement of density, dimensions and shape. These measurements must be supplemented in the inspection of solvent cordites by measurement of 'wet weight' per unit length as the first pressings from each incorporator load appear (as a check on variability of solvent content). However, there is good evidence that closed-vessel firings can markedly reduce the number of rounds necessary for gun proof of propellants.

### General characteristics of propellants for guns

23. Before leaving the subject of gun propellants it is convenient to review some of their general properties. They are usually non-porous colloids (which assists in their conformance with Pöbiert's law) but may be deliberately made porous if a very 'fast' powder is required. They all have a low thermal conductivity and ignite in the range 150°C to 170°C. Since the cordites are adversely affected by both

\* At the time of writing the recorder system is being redesigned so that its readings will be more amenable to computer treatment.

heat and sunlight (which promote chemical, and hence physical, degradation) care should be taken to protect cordite charges from undue exposure to these effects. Because nitrocellulose powders contain a residue of solvent, and because they are somewhat hygroscopic, they should be kept well sealed.

24. Obviously, at very low climatic temperatures propellants may become embrittled, with adverse effects on gun ballistics, and this has once or twice been observed with picrite cordites of low density. Another problem with cordites at low temperatures is that, over a period, nitroglycerine may crystallize out on the surface of the propellant; on thawing, this NG remains on the surface as a liquid 'sweat', which may be reabsorbed if the temperature remains above freezing point, but there is the risk that it may contaminate adjacent materials. (Below 13°C pure nitroglycerine freezes, usually slowly because it has a marked tendency to remain supercooled, a tendency which is accentuated when the NG is in solid solution with nitrocellulose.) Cordites made by the solventless process appear much less prone to this exudation of NG than were the earlier solvent cordites (for example, Mark 1 cordite), and in general the effect is less likely to occur with compositions employing the more 'soluble' grades of nitrocellulose (that is, of nitrogen content less than 13.0%): the only known recent example of NG exudation occurred in a ballistite (made with guncotton-type nitrocellulose) in conditions of extreme cold in Germany. The obsolescent cordites containing mineral jelly may exude this substance at temperatures above 10°C, but this effect will not readily be confused with the exudation of NG.

25. Reference was made earlier in para. 14 to different shapes of propellant. In the cord (or stick) the length is great in comparison with the diameter; as the cord burns all over, its surface becomes smaller, so that the rate of gas evolution falls off. Such a form is called 'regressive' and tends to give a 'peaky' pressure curve. In theory this state of affairs should be remedied by the use of a tubular form, which should be 'neutral' since the combined perimeters of the internal and external surfaces should remain constant; in fact, however, the tubular form is slightly regressive, owing to slower (and irregular) burning on the internal surface, while the tube may burst because of build up of internal pressure. These problems are largely overcome by the use of the slotted tube (a tube slit along its length); as soon as the propellant starts to burn, the slit opens up and relieves internal pressure.

26. Multi-tubular propellant (usually having seven tubular holes each of diameter about one-tenth that of the overall external diameter) is employed not in long form but in 'grains' having a length about two-and-a-half times the external diameter; thus internal pressures cannot build up to disrupt the grain, which burns 'progressively' until the webs have burned through to give six internal and six external 'slivers' which burn regressively, so that the whole charge is burnt rather earlier in the gun process than is a charge of cord or tube. Such granular charges require careful design of the ignition system to ensure that sporadic high pressures do not occur, particularly at high densities of loading and at low charge temperatures. The strip (or ribbon) form of propellant is slightly regressive; it is not much used in the British Service but is employed in the Swedish Bofors cordite and in the French Poudre B. Ballistite square flake is a 'quick' form used for mortar primary charges.

27. In general, a form of propellant which can be poured into a cartridge case is better suited to modern ammunition filling processes than is a propellant in the form of long sticks.

#### Factors influencing design of rocket-motor solid charges

##### *Combustion-chamber operating pressure*

28. Because in a rocket (as opposed to a gun) the combustion chamber travels with the missile, on considerations of weight the combustion chamber cannot be a high-pressure vessel. It follows that the pressures at which solid propellants are burnt in the combustion chamber of a rocket must be relatively low; in practice, the range is from about 500 lb/in<sup>2</sup> to 2000 lb/in<sup>2</sup> (3.5 MN/m<sup>2</sup> to 13.8 MN/m<sup>2</sup>). (But there is a tendency for the working pressure to be raised in the interests of higher performance and improved accuracy.) It follows also that the rocket-motor designer will be anxious that, while the fullest use can be made of the design pressure in the chamber, excessive pressures shall not arise. The margin between designed working and maximum (burst) pressures must be as small as possible. (The burst pressure is usually only about 1.6 times the designed working pressure at normal ambient temperature.) Thus there must be no question of *n*, Vieille's pressure index, approaching unity; in fact, the lower it is the better, for from the expression

$$r = ap_c^n \quad \text{--- (21)}$$

where  $p_c$  is the (fixed) chamber pressure, it can be seen that the lower the value of  $n$  the lower that of  $r$ , and therefore the less the tendency to produce gases more rapidly than they can emerge from the nozzle. (See also the remarks in para. 38.)

29. The rate coefficient,  $a$ , is substantially affected only by the temperature of the propellant charge, for if  $r$  is plotted against  $p_c$  on log paper for charges at different temperatures the result is a series of parallel sloping straight lines of which the upper ones correspond to the higher temperatures.

*Rocket thrust*

30. In a rocket motor a (usually) cylindrical combustion chamber, closed at one end, leads at the other end to a throat to which is fitted a divergent cone, so that the gases from the chamber reach the atmosphere *via* what is described as a 'convergent-divergent nozzle'. It can be shown that the thrust,  $F$ , of a jet of gas of  $w$  weight units per second so issuing through the exit plane of such a nozzle with average velocity  $v_e$  is

$$F = v_e w/g + (p_e - p_a)A_e \quad \text{--- (22)}$$

where  $p_e$  is the pressure at the exit plane whose area is  $A_e$ ,  $p_a$  is the atmospheric pressure and  $g$  is the gravitational constant. The first term of this expression is the contribution due to the momentum of the gas and the second is that due to the pressure difference at the exit plane. (It will be noticed that the thrust is independent of the velocity of the rocket, but increases as the atmospheric pressure falls. But see also para. 32, sub-para. 4 regarding equation 25.)

*Gas relationships*

31. Assuming that the gas is 'perfect', which is nearly true for hot rocket gases, it can be shown from the ordinary gas laws and the laws of conservation of mass and energy that the following relations hold, provided that the ratio of  $p_c$ , the chamber pressure, to  $p_a$ , the external pressure, is above a certain small critical value (about 1.9):

$$w = A_t p_c \left[ \frac{R\gamma}{RT_c} \left( \frac{2}{\gamma + 1} \right) (\gamma + 1)/(\gamma - 1) \right]^{\frac{1}{2}} \quad \text{--- (23)}$$

$$v_t = [2g\gamma RT_c/(\gamma + 1)]^{\frac{1}{2}} = [g\gamma RT_t]^{\frac{1}{2}} \quad \text{--- (24)}$$

$$v_x = v_t \left[ \frac{\gamma + 1}{\gamma - 1} \left\{ 1 - \left( \frac{p_x}{p_c} \right)^{\frac{\gamma - 1}{\gamma}} \right\} \right]^{\frac{1}{2}} \quad \text{--- (25)}$$

$$A_x = A_t \left( \frac{2}{\gamma + 1} \right)^{1/(\gamma - 1)} \left( \frac{p_c}{p_x} \right)^{1/\gamma} \left( \frac{v_t}{v_x} \right)^{\frac{1}{2}} \quad \text{--- (26)}$$

where

$A_t$  and  $A_x$  are the respective cross-sectional areas of the throat and of a plane section ( $x$ ) between throat and exit.

$v_t$  and  $v_x$  are the corresponding gas velocities;

$T_c$  and  $T_t$  are the chamber and throat temperatures;

$p_x$  is the pressure at the plane ( $x$ );

and the other quantities are as previously used in this Chapter.

32. From these relationships (equations 23 to 26) a number of conclusions may be drawn which are as follows:

(1) from equation 23

$$w = \text{constant} \times A_t p_c \quad \text{--- (27)}$$

for a given gas composition and chamber temperature

(2)  $v_t$  is exactly the velocity of sound in the gas at the temperature prevailing in the throat, so that the conditions of the gas in the chamber are independent of anything happening downstream of the throat

(3) from equation 25,  $v_x$  is greater than  $v_t$ , that is, conditions downstream of the throat are supersonic

(4) if  $x = e$ ,  $v_e$  and  $p_e$  can be deduced from equations 25 and 26.  $v_e$  is not quite the  $\bar{v}_e$  of equation 22, which is the average of the components of  $v_e$  along the axis of the nozzle, whereas  $v_e$  refers to the velocity along a (diverging) stream line in the nozzle; in fact, it has been shown that  $\bar{v}_e = \lambda v_e$ , where  $\lambda$  depends only on the nozzle cone angle.

Thus equation 22 can be rewritten:

$$F = \lambda v_e w/g + (p_e - p_a) A_e \quad \text{--- (28)}$$

From the deduced values of  $p_e$  and  $v_e$  it can be shown that  $F$  is a maximum if  $p_e = p_a$ , that is, if the value of  $A_e$  is such that the gases in the nozzle are brought to the atmospheric pressure prevailing at the exit plane.

This is because the 'efficiency term'

$$I = \left[ \frac{p_e}{p_c} \right]^{(\gamma - 1)/\gamma} \quad \text{----- (29)}$$

in equation 25 is at its maximum when  $p_e = p_a = p_a$ , so that  $v_e$  is a maximum.

33. The foregoing outline theory is an idealized one, but it provides a good approximation in simple examples.

*Specific impulse*

34. Turning now to the criteria of performance of the gases produced in the combustion chamber, it is usual to define their thrust per unit weight as their 'specific impulse' defined by

$$I_s = F/w \quad \text{----- (30)}$$

$$= \frac{\lambda}{g} v_e \quad (\text{from equation 28 when } p_e = p_a) \quad \text{----- (31)}$$

and hence, from equations 24 and 25:

$$I_s = \frac{\lambda}{g} \left[ \frac{2g\gamma R'T_c}{(\gamma - 1)M} \left\{ I - \left[ \frac{p_e}{p_c} \right]^{(\gamma - 1)/\gamma} \right\} \right]^{1/2} \quad \text{----- (32)}$$

where  $R'$  (the universal gas constant) equals  $MR$ ,  $M$  being the mean molecular weight of the gases. Thus  $I_s$  (the usually quoted units for which are seconds but the true practical definition of which is pounds force  $\times$  seconds per pound mass, that is,  $\text{lb} \times \text{sec}/\text{lbm}$ ) is proportional to the square root of the mean molecular weight of the gaseous products of combustion of the propellant. It can thus be calculated by thermochemical methods.\*

35. Since  $T_c$  is nearly proportional, for a given gas composition, to the heat of reaction of the propellant, it can be seen from equation 32 that an efficient propellant is one with a high heat of reaction that produces gases of low average molecular weight — whence the high efficiency of hydrogen-oxygen systems, where these are practicable on other grounds.

36. From equation 30 it can be seen that if the thrust and rate of consumption of propellant are constant during a time  $t$ :

$$I_s = Ft/wt \quad \text{----- (33)}$$

The product  $Ft$  is called the total impulse, and its ratio to the overall weight of the motor, the 'overall specific impulse' of the motor, is a criterion of motor efficiency; this ratio implies that low-weight hardware must be combined with a propellant of high specific impulse.

*Rocket-motor stability*

37. Returning to consideration of a solid propellant charge of surface area  $S$  (exposed to burning) and density  $d$ , the mass rate of burning is  $Srd$ , which from equation 21 is  $aSdp_e^n$ . From equation 23 it can be seen that the mass rate of discharge through the rocket nozzle is  $bp_e$ , where  $b$  is a constant. For stable operation these two quantities must be equal, but if anything happens to cause  $p_e$  to increase by a small increment  $\delta p_e$  they become, to a first approximation, respectively

$$aSdp_e^n \left\{ I + n \frac{\delta p_e}{p_e} \right\} \quad \text{----- (34)}$$

\* For solid propellant rocket motors it is usual to quote specific impulse for an operating pressure of 1000  $\text{lb}/\text{in}^2$  (6.9  $\text{MN}/\text{m}^2$ ) with expansion to normal atmospheric pressure (14.7  $\text{lb}/\text{in}^2$ , 101  $\text{KN}/\text{m}^2$ ), but sometimes the rather larger value of the 'vacuum specific impulse' — resulting from expansion to zero pressure or to 0.1  $\text{lb}/\text{in}^2$  (6.9  $\text{KN}/\text{m}^2$ ) may be quoted. In the instance of liquid propellant motors it is more usual to assume an operating pressure of 300  $\text{lb}/\text{in}^2$  (2.1  $\text{MN}/\text{m}^2$ ).

and

$$bp_c \left( 1 + \frac{\delta p_c}{p_c} \right) \quad \text{--- (35)}$$

so that the ratio of the rate of production to the rate of removal of gas is

$$\frac{1 + n \frac{\delta p_c}{p_c}}{1 + \frac{\delta p_c}{p_c}} \quad \text{--- (36)}$$

38. Clearly, if  $n$  is greater than unity, the rate of gas production will exceed its rate of removal — with ultimate bursting of the combustion chamber. But if  $n$  is less than one, an upward disturbance of the operating pressure will increase the rate of removal of the gas more than it does the rate of production; so that the only effect will be stable operation at the slightly higher pressure; once the disturbing influence is removed, the normal operating pressure will quickly be re-established. Thus a pressure exponent less than unity is essential for the stable operation of a rocket motor.

39. Although the factors which control the value of  $n$  for a propellant composition, whether double-base or composite, are not yet well understood, it is found in practice that at moderate rocket-motor operating pressures (ca 1000 lb/in<sup>2</sup>, 6.9 MN/m<sup>2</sup>),  $n$  usually lies in the range 0.4 to 0.65. Values of  $n$  as low as 0.2 to 0.3 at 1000 lb/in<sup>2</sup> (6.9 MN/m<sup>2</sup>) have been found for composite propellants having a polyurethane rubber matrix.

*Platonization*

40. About 1950 it was found accidentally that the addition to 'cool' double-base propellant compositions (of calorimetric value less than 1000 cal/g) of about 2% of certain lead compounds resulted in a change in the plot on log paper of  $r$  against  $p$ . Instead of a sloping straight line over the whole pressure range it was found that at a relatively low pressure the line became almost parallel to the  $p$  axis and remained so for a range of several hundred pounds, after which it again sloped upwards (at an angle rather greater than that for the propellant without lead content). The parallel (or horizontal) part of the curve became known as the 'plateau' and the effect was then described as 'platonization' (Fig. 1).

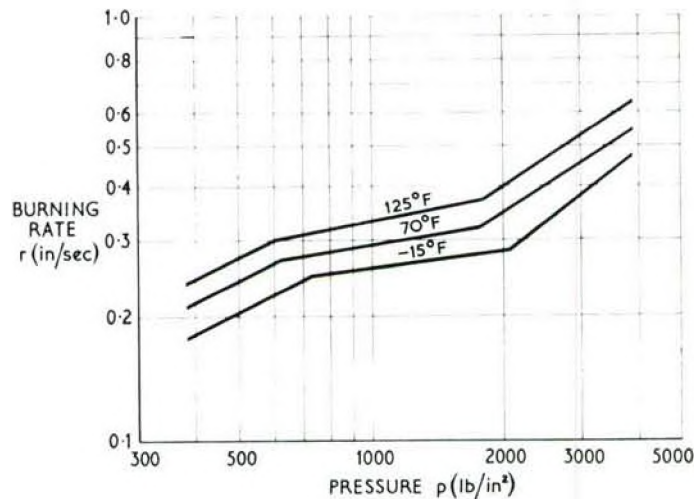

Fig. 1 Example of variation of burning rate with pressure for platonized CDB propellant

41. Just as the burning of an unleaded propellant at different temperatures gave a set of parallel sloping straight lines, so the burning of a leaded propellant at different temperatures gave a set of 'parallel' plateau-shaped lines. If a leaded propellant could be found which was platonized over a pressure range including the desired motor-operating pressure, the designer's wish for a propellant having  $n = 0$  was met. (In fact, of course, values less than zero would be even better, if they could be obtained.) A few compounds of elements other than lead have been found to give a limited degree of platonization at some pressure, but lead (and, to some extent, copper) compounds are the only ones of

practical value — and then only provided that the presence of finely divided metal oxide in the exhaust gases is acceptable, which may not be so with all low-pressure devices.

42. At an operating pressure of 1000 lb/in<sup>2</sup> (6.89 MN/m<sup>2</sup>) unplatonized cordites are available to give rates of burning from 0.13 to 0.7 in/sec (3.3 to 17.8 mm/sec), and platonized ones from 0.2 to 0.7 in/sec (5.1 to 17.8 mm/sec). Platonized cordites giving appreciably higher rates of burning at higher pressures are also recorded (ERDE Tech Report No. 3, July 1969).

#### *Mesonization*

43. Shortly after the discovery of platonization it was found that one or two lead compounds gave a plateau of unusual shape in the log plot of  $r$  against  $p$ ; at a certain pressure the rising straight line turned to a saddle-shaped curve with a shallow hump and following depression more or less symmetrically disposed about what would otherwise have been the plateau line. This type of curve was known as a 'mesa', and it was found that if a 'mesonized' propellant was burnt at different temperatures the log plots of  $r$  against  $p$  usually crossed or nearly coincided at a point on the negative gradient part of the curves. Over their mesa pressure range such propellants had a rate of burning not only moderately pressure invariant but also nearly temperature invariant — a property valuable to the motor designer. (See Fig. 2.)

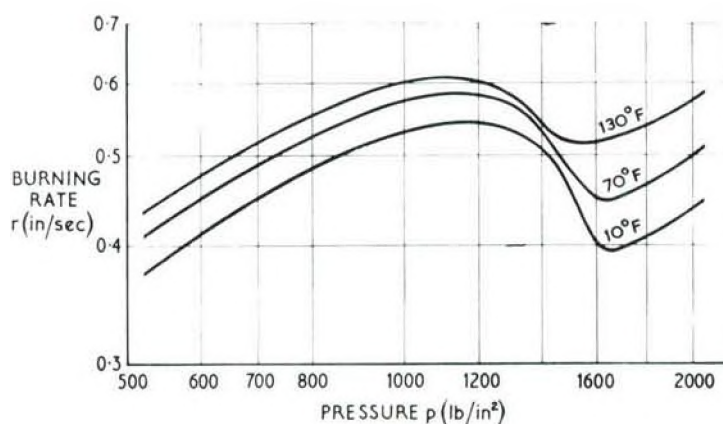

Fig. 2 Example of burning-rate curves for mesonized propellant

44. In the field of composite propellants the mesonization effect has never been observed, whilst only a limited degree of platonization has been obtained with some plastic propellants by the incorporation into them of oxamine. As noted previously, some rubbery composites have such low values of  $n$  as to be almost platonized over the whole range of reasonable operating pressures.

#### *Nature and properties required of propellant charge*

45. In the light of what has been discussed it is now possible to consider what must be the nature and properties of a propellant charge for a rocket motor (or for any other low-pressure device). These considerations are summarized as follows:

- (1) the charge must consist of a uniform, compact, non-porous propellant in a suitable geometrical form to yield product gases of low molecular weight in specified and controlled amount
- (2) the charge must occupy as much as possible of the motor volume, to give an optimum relationship between hardware weight and charge weight
- (3) the propellant, of as high a density as feasible, must be capable of yielding as much energy per unit weight as possible (that is, the specific impulse must be as high as possible) consistent with a flame temperature which can be tolerated by the hardware
- (4) the propellant must have an appropriate rate of burning at the operating pressure combined with a pressure index as low as possible (and in any event less than unity) and, if possible, temperature invariance of rate of burning. (Note: As with the other considerations mentioned in this paragraph, the remark about a low pressure index refers to the 'pure' rocket motor. But, a burning rate sensitive to pressure would be helpful in air-augmented rockets, solid-fuel ramjets and variable thrust motors using a variable nozzle.)
- (5) the propellant must have physical properties which will enable the charge to withstand: (a) climatic changes in storage over the expected military operating range of temperatures and (b) imposed forces during ignition and flight. It must, of course, also be chemically stable.

46. From among the propellants (double base, cast double base, composite and composite modified cast double base) described in Chapter 8, it is not difficult to meet requirement (1), in para. 45, but the ideal

'universal' solid propellant to meet all the other requirements has not yet emerged and some degree of compromise is called for as each example arises.

47. The problem of geometrical form for a motor which is to have a level pressure-time curve usually resolves itself into that of devising in a cylindrical charge one or more internal conduits of such shape that as the propellant at their surface burns away that surface regresses in such a manner as to remain of constant area. The outer surfaces of the cylinder must usually be inhibited to prevent their burning, since they would inevitably become smaller, with consequent fall-off of the rate of gas evolution. It is a design exercise to develop a conduit pattern which will regress with constant surface area; a much-favoured design is an axial hole in the form of a six-pointed star, another is an axial hole of clover-leaf pattern and yet another design has an axial cylindrical hole surrounded by three segmental slots (all so dimensioned that the webs of propellant will burn out simultaneously). But it is, of course, also possible to design a charge to produce a pressure-time relationship having special properties; thus there may be provision for a larger burning surface at commencement of burning than later, or to employ layers of propellant having different burning rates, or to limit or exaggerate the 'tail-off' of thrust at the end of burning. A very long-burning charge must be a solid chord burning endwise (like a cigarette). In practice some allowance has to be made for the 'erosive burning' which takes place in these various designs due to 'gas wash' in the conduits as the gases stream towards the motor throat.

48. To meet requirement (2) in para. 45 ideally, a case-bonded charge is best (that is, one in which the outer surfaces adhere, or are stuck, to the walls of the motor), and it was to meet requirement (2) that the concept of a plastic propellant was developed in the 1939-45 War. However, a case-bonded propellant charge must be capable of withstanding the forces arising from the relatively differing coefficients of expansion of propellant and motor hardware, otherwise either the bond between wall and charge will break or the propellant will crack, thus forming in either event new and uncovenanted burning surfaces, with risk of excess pressure developing and bursting the motor on firing.

49. What degree of thermal stress can be withstood depends not only on the propellant but on the size of the motor and the design of the charge. Cordite is very unsatisfactory for case-bonding, but some heavily plasticized CDB and CMCDDB charges can be bonded to withstand reasonable temperature changes (such as are met with in naval vessels) if the motor walls are linked with a suitable rubbery composition (the high plasticizer content lowers the 'brittle point' by some 20°C). Plastic propellant based on plasticizer-modified polyisobutylene binder can be case-bonded to give satisfactory results in a 15-inch (381 mm) diameter motor when temperature-cycled between 0°F (-17.8°C) and +120°F (48.9°C), while some rubbery composite propellants would withstand -60°F (-51.1°C) to +160°F (71.1°C) in such a size. Before leaving this subject it may be remarked that the use of glass-fibre reinforced plastics cases, instead of steel, does not alleviate the problem since the coefficient of expansion of such materials is comparable with that of steel.

50. As regards requirement (3) in para. 45, the specific impulse of a propellant composition can be calculated (equation 32), as can its flame temperature. The specific impulse can also be determined from the measurable value of the thrust developed in a small 'static proof' motor (equation 33). Practicable solid propellants usually have densities in the range 1.55 to 1.8 g/ml and can have a specific impulse of up to about 245-250 lb (111-113 kg) weight per lb (0.45 kg) of propellant burned per sec. Their flame temperatures range from about 2500 K to 3500 K.

51. As for requirement (4) in para. 45, the  $r$ - $p$  relationship of a propellant can be determined by:

- (1) by measuring the rate of burning of thin cords of the propellant (inhibited on their long surface by dipping in a lacquer) in a pressurizable vessel, or
- (2) by the 'interrupted burning' technique in which a measured cylindrical piece of propellant is burned in a pressurized vessel for a given time when it is extinguished by a sudden release of pressure and remeasured, or
- (3) in the same small motor in which thrust is measured, by firing several motors at different operating pressures.

The linear burning rates of solid propellants usually lie in the range 0.1 in/sec (2.54 mm/sec) to 0.2 in/sec (5.08 mm/sec) at rocket motor pressures (usually 1000 lb/in<sup>2</sup>, 6.89 MN/m<sup>2</sup>), but higher values can be obtained by special methods.

52. The in-flight forces referred to in requirement (5) para. 45 may be applied very rapidly, arising as they do from accelerational changes (although the highest rate of strain with a case-bonded charge occurs during ignition, when a pressure impulse is applied to the system by the igniter). The ability of a propellant to withstand them can be assessed by high-rate-of-strain physical tests specially developed for laboratory use.

53. In the course of the development of a rocket motor, 'static proof' motors of several sizes may be made and fired in an approach to the final motor, and some of them may be subject to 'flight proof' firings to obtain answers to design problems, whether related to the propellant charge or to the hardware.

## RESTRICTED

Among the *ad hoc* problems with which the propellant technologist has to contend are those of reliable inhibition, case-bonding and those of thermal insulation of the hardware, if only because whatever solutions to these problems are evolved, they must be such that the materials employed will be compatible with the propellant.

54. Ostensibly, if the charge is case-bonded, problems of heat insulation do not arise since, as the charge burns outwards from its conduit, the propellant acts as a heat insulator; but, in fact, the part of the case leading to the nozzle throat must be heavily insulated, whilst it is desirable to provide some insulation between the case wall and the propellant in anticipation of the time when the remaining web of the latter becomes thin. Moreover, a judicious choice of an insulating material, and of its design, can assist in taking up thermal stresses between case and charge. Thus considerable work has been done on suitably loaded rubber compositions to act as insulating layers and on adhesive systems to bond them to both case and charge; in the course of this work it was found necessary to pay careful attention to the drying of the rubbers in order to obtain good adhesion. Each class of propellant tends to call for a different solution, and a great deal of ingenuity is called for to obtain reliable adhesion of propellants containing nitroglycerine or other ester plasticizers which tend to migrate into, and so weaken, most adhesives.

55. A topic to which some reference ought to be made is that of 'smoke and flash' both of which are undesirable in military rockets. Disregarding the influence on them of the engineering design of the nozzle, the propellant chemist is somewhat limited by considerations of energetics. If the propellant composition contains no metals (for example, aluminium) or burning-rate catalysts (for example, lead compounds or metallic oxides) or halogen compounds (for example, ammonium perchlorate), it may be fairly smokeless if its specific impulse is below about 190, above which value it will give a more or less strong exhaust flame ('flash'). If any of the aforementioned substances have had to be incorporated into the propellant, a degree of smoke is inevitable and will be the more obvious in humid conditions (especially where ammonium perchlorate is concerned, giving rise as it does to hydrogen chloride in the exhaust gases). Another complicating factor is the smoke arising from inhibitory materials which may have been employed to restrict burning surfaces and also the smoke from materials used for thermal insulation of the case from the hot gases.

APPENDIX A

**A Simplified Method for the Calculation of the Adiabatic Flame Temperature of Gun Propellants**

**A1.** For the many possible constituents of propellants, Tables have been prepared giving the energy released per gramme at 2500 K, the mean specific heats at constant volume, ( $C_v$ ), of the products between 2000 K and 3000 K and the sum of the number of gramme molecules of the gaseous products. An extract from these Tables is given in Table A1 of this Appendix.

**A2.** If  $E_{2500}$  is the energy released at 2500 K, the energy released at any other temperature,  $E_T$ , is given by

$$E_T = E_{2500} - (T - 2500)C_v \quad \text{--- (A1)}$$

At  $T_a$ , the adiabatic flame temperature, no energy is released, so that

$$E_{T_a} = 0 = E_{2500} - (T_a - 2500)C_v \quad \text{--- (A2)}$$

$$\text{or } T_a = \frac{E_{2500}}{C_v} + 2500 \quad \text{--- (A3)}$$

It is assumed that  $E$ ,  $C_v$  and  $n$  for a propellant are additive functions of those of its constituents, that is:

$$E = \sum x_i E_i$$

$$C_v = \sum x_i C_{vi}$$

$$n = \sum x_i n_i$$

where  $x_i$  is the weight fraction of the  $i$ th constituent

**A3.** An actual example, using cordite SC, will make the calculation of adiabatic flame temperature clear. The composition per gramme of cordite SC is:

Nitrocellulose (N = 12.2%) .....	0.50 gramme
Nitroglycerine .....	0.41 gramme
Carbamite .....	0.09 gramme

This composition gives the following energy, specific heat, adiabatic flame temperature and product results:

- (1) Calculation of energy released at 2500 K:
 

$E$ (nitrocellulose)	= 0.50 (283.1 - 153 × 0.95)	= 68.87 calories
$E$ (nitroglycerine)	= 0.41 × 951.9	= 390.28 calories
$E$ (carbamite)	= 0.09 × -2732.9	= -245.96 calories
Whence total energy	= 213.19 calories	
- (2) Calculation of mean specific heat at constant volume:
 

$C_v$ (nitrocellulose)	= 0.50 (0.3421 + 0.006 × 0.95)	= 0.1739
$C_v$ (nitroglycerine)	= 0.41 × 0.3439	= 0.1410
$C_v$ (carbamite)	= 0.09 × 0.3409	= 0.0307
Whence total $C_v$	= 0.3456	
- (3) Calculation of adiabatic flame temperature,  $T_a$ :
 

Using equation A3 developed above gives:

$$T_a = 213.19/0.3456 + 2500$$

$$= 3117 \text{ K (see footnote)} \quad \text{--- (A4)}$$
- (4) Calculation of the number of gramme molecules of gaseous products:
 

$n$ (nitrocellulose)	= 0.50 (0.03920 + 0.00218 × 0.95)	= 0.02064
$n$ (nitroglycerine)	= 0.41 × 0.03083	= 0.01264
$n$ (carbamite)	= 0.09 × 0.10443	= 0.00940
Whence total $n$	= 0.04268	

RESTRICTED

This result again compares favourably with the value 0.04266 obtained by more detailed calculation.

It is possible to apply corrections for dissociation, but reference must be made to the original reports for the method used.

Note: The method of successive approximation ('Internal Ballistics', HMSO, 1951 — Chapter 2) yields a value 3107 K before making allowance for the dissociation which occurs at this temperature and which, when allowed for, yields a rather lower result (3090 K).

**Table A1**

**Additive constants of propellant compositions**

(Abstract from OSRD Reports 935 and 1300 — these data are subject to revision — see ERDE Tech Note No. 3, May 1969)

	<i>E</i>	<i>C<sub>v</sub></i>	<i>n</i>
Nitrocellulose	283.1 - 153 <i>a</i>	0.3421 + 0.006 <i>a</i>	0.03920 + 0.00218 <i>a</i>
Nitroglycerine	951.9	0.3439	0.03083
Diphenylamine	-3009.7	0.3475	0.10645
Carbamite	-2732.9	0.3909	0.10443
Nitroguanidine (picrite)	- 52.8	0.3711	0.04806
Dinitrotoluene	- 668.4	0.3213	0.06042
Water	-1567.6	0.6507	0.05551
Dibutylphthalate	-2656	0.4261	0.09707
Ethyl alcohol	-2784.8	0.6085	0.10858
Acetone	-2842	0.5107	0.10336
Mineral Jelly	-4175	0.5983	0.142
Potassium nitrate	24.9	0.2158	0.00989
Barium nitrate	131	0.1574	0.00765
Potassium sulphate	- 800	0.125	0.00574
DINA (Dinitroxydiethylnitramine)	500.9	0.3653	0.04165
RDX	622.3	0.3541	0.0405
Nitrodicyandiamidine	- 252.3	0.3541	0.04761

*E* is the energy released at 2500 K (gramme cal/gramme)

*C<sub>v</sub>* is the mean specific heat of gaseous products from 2000 K to 3000 K at constant volume

*n* is the number of moles of gas formed per gramme

*a* = 13.15 - %N

**CHAPTER 13**

**Explosive Munitions**

**CONTENTS**

	<i>Para</i>
<b>General</b> .....	1
<b>Fuzes</b> .....	2
<i>Mechanically-operated fuzes</i> .....	3
<i>Electrically-initiated fuzes</i> .....	7
<b>Choice of explosive filling</b> .....	9
<i>Stability and compatibility</i> .....	11
<i>Figure of insensitiveness (F of I)</i> .....	12
<i>Melting point and volatility</i> .....	13
<i>Problem of exudation</i> .....	15
<i>Detonative performance</i> .....	17
<i>Ease of industrial working</i> .....	25
<i>Performance and use in Service</i> .....	32

**Illustrations**

<i>Fig</i>	<i>Page</i>
1 Fuze, percussion, DA, No. 944 Mk. 1 .....	4
2 Blast-wave pressure/time relationships .....	7
3 A hollow-charge weapon (simplified) .....	8

**Tables**

<i>No</i>	<i>Page</i>
1 Fragment velocity relation for various explosives .....	7

## CHAPTER 13

## Explosive Munitions

**General**

1. Although it is not relevant to this book to discuss in detail the design of explosive stores, it is appropriate to consider briefly some of the factors which enter into the choice of explosives for munitions and some of the problems which have arisen in developing viable fillings and filling processes. Problems which can arise from the presence of moisture in fillings, or from its ingress into stores, have been remarked on at various points in this book and discussions of compatibility questions will be found in Chapter 11 and 15. (See also para. 11 of this Chapter.)

**Fuzes**

2. In general, the functioning of modern explosive munitions begins with a mechanical or electro-thermal stimulus which initiates a series of events in an explosive train in a fuze, although a combination of both mechanical and electrical stimuli may be used in some fuzes. The igniters, detonators and delays used in fuze trains are available in a variety of sizes, depending on the requirements of, and the space available in, individual fuzes.

*Mechanically-operated fuzes*

3. Mechanically-operated fuzes are used widely where advantage can be taken of the acceleration or retardation or spin of a projectile (shell, bomb and mine fuzes, and some rocket-operated systems). One of the simplest explosive trains is that in a direct-action percussion fuze, operating by needle-stab on impact without delay action. The explosive train consists of an LZ Y detonator which communicates its shock to tetryl, stemmed at a density of 1.2 to 1.3 g/ml into a channel; the tetryl in turn detonates a tetryl booster pellet (density 1.45 to 1.55 g/ml). The LZ Y detonator (which, in the 'unarmed' position, is out of line with the tetryl train) contains a layer of L Mixture\* (Chapter 9), a layer of lead azide ('Z') and a layer of tetryl ('Y'); the stab of the needle on impact ignites the L Mixture, which detonates the azide which detonates the tetryl. Thus the detonator brings the tetryl train and pellet into action to produce a sufficient quantum of energy to detonate the shell filling. Sometimes the tetryl pellet is replaced by one of RDX/Wax (93/7).

4. If a post-impact delay is required, as in the L 32 fuze (AP 110L-0301-1, Chapter 5-1), it is arranged that the needle stab shall act on a cap (sometimes called an 'ignitory detonator') containing only L Mixture, 1.7 grains (110 mg), the flash from which ignites two delay elements which in turn ignite a flash-receptive 1.5 grain (97 mg) RZY detonator, which is loaded with layers of LDNR (RD 1337 — Chapter 9), lead azide and tetryl; this detonator is closed only with silk gauze and NC varnish, which is permeable to flash. The L 32 fuze can be set for instantaneous operation by opening a setting bolt which provides a channel directly from the L Mixture cap to the RZY detonator; however, the fuze for the 30 mm ADEN shell requires only a delay element, since detonation on impact would be markedly less effective than detonation inside the fuselage of an aircraft. A diagram of the 30 mm Aden fuze is given in Fig. 1. The safety and arming devices (the centrifugal bolts and the shutter) are actuated (that is disengaged) as a consequence of the rotation of the shell. During flight, the deceleration of the projectile prevents the hammer from forcing the striker on to the detonator, but on impact the nose of the fuze is crushed and the striker is driven on to the detonator. A detailed explanation of the fuze is given in AP 110L-0201-1, '30 mm ammunition and fuzes'.

5. The L33 fuze (AP 110L-0301-1, Chapter 5-2) can give direct action on impact or can be preset to ensure an air burst. In direct impact action a 1.7 grain (110 mg) L Mixture device is ignited by needle stab and ignites RD 1337, the flash from which ignites a 1.5 grain (97 mg) RZY detonator. If an air burst is required a mechanical clock releases a needle to effect the ignition by stab of 4.1 grain (265 mg) of L Mixture in a detonator shell which acts directly on the same RZY detonator; the igniter here has to be large because it is not in direct line with the RZY detonator which, as in the L 32 fuze, detonates a tetryl train.

6. When space permits, as in modern bomb fuzes, it is possible to achieve reliable initiation of a conventional tetryl stemming without the use of lead azide (disadvantages of which are mentioned in Chapter 9) by employing one of the newer initiating compositions, RD 1359 (Chapter 9). In Fuzes 947 and 951, a 0.6 grain (39 mg) L Mixture cap ignites the previously chosen one of three (Fuze 951) or five (Fuze 947) delay elements, mounted in a rotor, which ignites a charge of RD 1359 which, in turn, initiates RDX (at low density in a shutter) which burns to detonation. (For a description of fuzes 947

\* L mixture — a mixture of R mixture (RD 1337, the lead salt of 2:4 dinitroresorcinate) in admixture with barium nitrate and tetrazene.

and 951 see AP 110F-0104-15NQ and 110F-0102-15NQ respectively.) The principle of 'burning to detonation', satisfactorily employed in these fuzes, has not hitherto readily been applicable to shell fuzes or to safety and arming units because of space limitations.

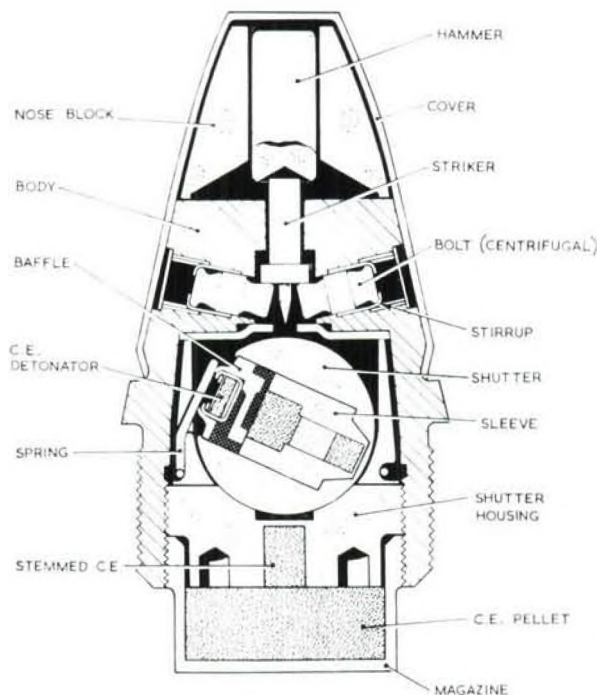

Fig. 1 Fuze, Percussion, DA No. 944, Mk. 1

#### *Electrically-initiated fuzes*

7. The electrically initiated devices are used in proximity fuzes and in guided-weapon safety and arming units (S and A units), although some early S and A units included a stab-initiated explosive train (beginning with a 1.7 grain, 110 mg. L Mixture igniter) to function on impact. The design of proximity fuzes and of S and A units is similar in principle and both employ a conducting composition (CC) igniter (Chapter 9). However, the limitations of space in a proximity fuze result in a tortuous flash path between the igniter and the detonator, which must be virtually unsealed in order to ensure reliable initiation. This lack of sealing led to failure of the RZY detonator in some fuze designs, owing to the effect of emanations from certain plastics components in promoting the hydrolysis of the exposed lead azide; consequently the RZY detonator is now obsolescent for these fuzes and is being replaced by the RWY detonator employing silver azide (Chapter 9). In still newer designs the combination of CC igniter and RZY or RWY detonator will be replaced by a CC detonator (a relatively well-sealed device) in which the conducting layer may be lead azide/graphite or (for low voltage, 16 volt functioning) lead azotetrazole (RD 1355)/graphite — in the former instance directly topped with RDX and in the latter followed by an increment of lead azide and topped by RDX, to give a detonative output.

8. Another electrothermal system, which also has a very short functioning time and which can be considered for guided weapon S and A units, which are not subjected to a particularly high acceleration, is the Exploding Bridgewire (EBW) detonator. In this device a fine gold bridgewire is covered with a secondary explosive such as finely divided PETN at low density; no primary explosive is employed. The discharge across the bridgewire of a suitable capacitor (say 0.5 $\mu$ F at 2kV) explodes the wire, hot particles of which initiate the explosive, which builds up to a full detonation in a second increment of filling at high density. This type of detonator has been approved for use in an unshuttered S and A unit, but would be unacceptable in a shell fuze because the use of neat PETN, unshuttered, is not approved on account of the high accelerations to which a shell is subject.

#### **Choice of explosive filling**

9. The qualities of principal importance in explosives which may be chosen as the main filling of a munition store are:

- (1) high chemical stability and compatibility
- (2) high figure of insensitiveness to impact and friction
- (3) adequately high melting point and low volatility

- (4) freedom from exudation
- (5) high detonative performance
- (6) capability of filling by an industrially acceptable process.

10. Only when these issues have been resolved, and reconciled where necessary with the performance specification for the store, is it possible to consider cost effectiveness. For a high-performance, single-shot weapon (an anti-tank guided missile or a torpedo warhead), cost is likely to be a fairly secondary consideration; however, cost might well militate against the use of an expensive explosive such as HMX in the filling of a comparatively inaccurate mass-effect weapon such as the 1000 lb MC aircraft bomb. Some amplification is now given of the qualities listed in para. 9.

#### *Stability and compatibility*

11. It is obvious that the possession by military explosives of good chemical stability will contribute to their safety in use and to a long Service life. It is equally obvious that such stability ought not to be degraded by anything with which they may come in contact (other explosives, materials of packaging or of construction of the final store, moisture, etc). The stability of the older explosives (TNT and tetryl) may be impaired by the presence in them of by-products arising during their manufacture, so that they have to be purified to the highest practicable degree before use. They are also liable to degradation in presence of alkaline conditions. TNT was adversely affected by pyridine (which is alkaline) and thiocyanates present in ammonium nitrate derived from gasworks ammonia; but this problem is less likely to be met with now that ammonium nitrate is made from synthetic ammonia and nitric acid. Ammonium nitrate suffers from the disadvantages of being hygroscopic, of forming sensitive copper and tin compounds and undergoing a phase change, with considerable change of density at 32°C. Its hygroscopic nature has led to its abandonment as an ingredient of fillings for munitions in peacetime, since it may cause severe internal corrosion of the store, sensitization and caking of the filling (amatol) into a hard mass which is difficult to detonate. The introduction of aluminium into explosive compositions has greatly emphasized the importance of excluding moisture during filling; the reactivity of aluminium with moisture may be enhanced if the material is of very fine particle size and if impurities are present in it. The modern explosives RDX and HMX have a high order of intrinsic stability to all but the more alkaline conditions, and PETN is more stable than might be expected from its nitric ester constitution, so that it is unlikely to be troublesome in the absence of acidity or considerable alkalinity.

#### *Figure of insensitiveness (F of I)*

12. In general, it is considered undesirable in the British Service to use as fillings explosives the F of I of which is below 100. As individual substances, RDX, HMX and PETN fail in this respect, and must be suitably desensitized with wax, oil or TNT, although this involves some loss of power and decrease in the velocity of detonation. But it must be remembered that the F of I is measured on only a small quantity of finely-divided explosive under conditions of relatively low confinement, so that it is not a true criterion of sensitiveness under all conditions, for example, when a bomb or shell strikes a hard target at high velocity, such factors as the strength and design of the casing and the quality of the explosive filling will require consideration. A filling of low density may contain cavities or cracks, and such fillings, as well as those which have become separated from the casing, may be brought to ignition by the adiabatic compression of the confined air on impact. It is usual to apply tests of 'Susan' type (Chapter 14) to potential filling compositions.

#### *Melting point and volatility*

13. The melting point of a filling composition must be such that it exceeds the highest likely environmental temperature which the store may be expected to meet, otherwise there is a risk of liquefied explosive migrating into other parts of the store and perhaps creating such a gap between the fuze and the residual charge that propagation of detonation is ineffectual, so that the store is either potentially dangerous or 'dudded' — or both. Normally, stores may be expected to be subject to maximum temperatures of 71°C in the tropics, but such a figure may be exceeded if precautions are not taken; a black surface in the sun in an American desert is said to have reached over 93°C, so that it is evident that munition stores in the tropics should be shaded (with adequate ventilation) and should be of as light a colour as possible. In recent times a requirement has arisen for munitions to be carried on the outside of supersonic aircraft, so that when the aircraft is flying at relatively low altitudes the skin temperature of the weapon may be quite high. It is seldom acceptable to coat the outside of the store with a thermal insulant, and therefore compositions of the higher melting point current explosives (for example RDX) have been developed for such use, and explosives of even higher melting point are becoming available (Chapter 6).

14. Just as melting may lead to migration of explosive from the main charge cavity to other parts of a store, so may an unduly high vapour pressure (volatility) result in sublimation of explosive from a warmer to a cooler part; TNT is only on the verge of acceptability in this respect, and care is necessary to ensure that any ingredients proposed for an explosive composition are free from risk of sublimation. Trinitrobenzene, which might otherwise be a useful substitute for TNT in some respects, is too volatile for use in military stores.

*Problem of exudation*

15. Exudation is a problem allied to that of adequacy of melting point. It came to notice in a serious way about the time of the 1914-1918 War, when methods for the purification of TNT were not well developed and five grades of TNT were listed as follows:

Grade	Setting Point (°C)
1	80.4 – 80.9
1a	80.0 – 80.9
2	79.5 – 80.9
2a	79.0 – 80.9
3	76.0 – 80.9

Only two grades are currently employed, with minimum setting points of 80.2°C and 80.4°C respectively. The depression of melting point from a maximum of 80.9°C is due to the presence in TNT of isomeric trinitrotoluenes and other related substances (Chapter 6) which result in the formation of low-melting point eutectics; for example, TNT of setting point 80.2°C is said to contain 5% of liquid matter which sets at 71°C. These eutectics may exude as an explosive oil from TNT-filled stores on prolonged storage at high ambient temperature, and from shell left to 'cook' in hot guns. The oil is considerably less sensitive than TNT, but its proneness to migrate into screw threads and other places where it may be 'nipped' when the store is subjected to shock (for example, on firing in a gun or on accidental dropping) is the cause of serious hazard since if ignited it can form a 'fire path' to the main filling. This type of exudation has become less of a problem as the purity of TNT has been improved, but it can arise when TNT is mixed with anything which is soluble in it; thus mixtures of TNT and tetryl, which have useful explosive properties, may melt at temperatures well below the melting point of TNT, and so such mixtures are not favoured as fillings. (The American 'tetrytol' — 70% tetryl and 30% TNT — melts at 68°C; in the cast form it has a density of 1.61 to 1.65 g/ml and a  $\sqrt{V}$  of D of 7350 m/sec.)

16. If TNT exudation does occur the problem may be intensified by the mutual solubility of the exudate and bitumen present in certain sealing compositions (for example RD 1064) used in shells and bombs; this increases the volume of liquid liable to exude on hot storage. (For this reason RD 1064 is replaced by RD 1284A whenever possible.) The desensitizing waxes may also present some exudation problems. It was customary to use beeswax, specified to melt within the range 61.5°C to 62.5°C, as a desensitizer, sometimes for TNT and invariably for RDX/TNT, HMX/TNT and the pentolites; such compositions tend to exude almost neat beeswax at temperatures up to about 70°C, but thereafter there is an admixture of TNT with the wax. While beeswax is still employed in RDX/TNT and HMX/TNT, it has been replaced by other waxes or by compositions of 'D.I' type (Chapter 7) in other explosives. Of course, when the exudate consists almost entirely of wax it must not be forgotten that it is leaving behind an explosive composition denuded of sensitizer; this aspect of the problem, when applied to the RDX/Wax compositions used in certain types of shell, led progressively to a change in specified setting point of paraffin wax from 55°C to 64°C ('High Melting Paraffin Wax') and then to the use of Indramic Wax (Wax 6 — melting in the range of 78°C to 85°C) and next of 'Wax 8', made by melting together suitable proportions of Wax 6 and polythene.

*Detonative performance*

17. In general, explosive fillings are required to produce either of two effects, brisance or blast, which may be differentiated by consideration of a plot of detonation pressure against time; a brisant explosive will give a high pressure peak, while a blast effect is characterized by a lower pressure maintained over a longer time. Brisance is required to break up the casing of a shell or a heavy-walled bomb to give small, high-velocity fragments. The detonation pressure,  $P$ , of an explosive is proportional to its density,  $\rho$ , and to the square of its velocity of detonation,  $D$ .

$$P \propto \rho D^2 \quad \text{--- --- (1)}$$

For a given casing the mean fragment velocity,  $\bar{V}$ , appears to be proportional to the square root of the detonation pressure, so that

$$\bar{V} \propto D(\rho)^{1/2} \quad \text{--- --- (2)}$$

which enables an approximate value for  $\bar{V}$  to be obtained in terms of measurable properties of the explosive. Some typical fragment-velocity values are given in Table 1.

18. The superior fragmenting power of modern explosive compositions containing HMX and RDX over that of TNT and the amatols — indicated by the order of placing in Table 1 — has received ample confirmation from detonation trials in which the fragments are collected and weighed and the weights and distances from the centre of detonation subjected to statistical analysis. The optimum fragment size

Table 1

## Fragment velocity relation for various explosives

Explosive	density $\rho$ g/ml	V of D m/sec	(V of D) $\times (\rho)^{1/2}$
EDC 1	1.80	8430	11300
RDX/Wax 91/9	1.61	8340	10500
RDX/TNT 60/40	1.68	7850	10180
Torpex 2	1.72	7373	9680
TNT	1.58	6810	8460
Minol 2	1.68	5820	7545
Amatol 60/40	1.50	5760	7050
Amatol 80/20	1.50	5100	6250

will depend on the target to be attacked; for personnel it is much smaller than for 'soft' vehicles and aircraft, and indeed much smaller than was at one time thought desirable — this is because fragment velocity also is an important factor in causing damage. High-speed cinematography and electronic timing between wire screens are methods employed to measure such velocities, which, for a given explosive, are found to vary with the square root of the charge-to-store percentage weight ratio,  $W$ , of the store. A rough approximation to the initial (maximum) velocity of the fragments is  $305 \times W^{1/2}$  m/second. Thus, for a well-designed, armour-piercing (AP) shell,  $W$  might be of the order of 6.25 per cent, whence the initial fragment velocity would be 760 m/sec; for an MC (medium capacity) bomb  $W$  might be 43 per cent, whence the fragment velocity would be 1980 m/sec. Average velocities of this order have been measured with high-powered fillings such as 60/40 RDX/TNT but the approximation is not valid for lower-powered fillings such as 80/20 Amatol, where the average velocity for a similar bomb is only about 1520 m/sec.

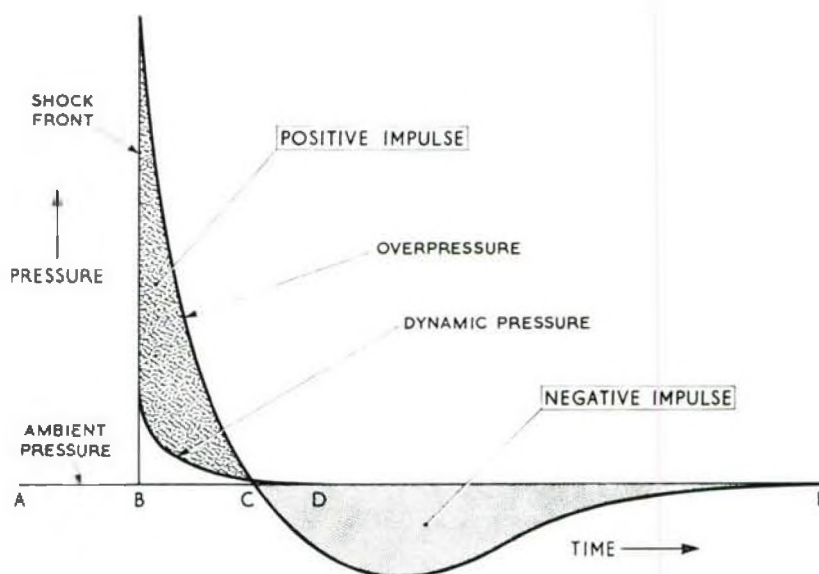

Fig. 2 Blast-wave pressure/time relationships

19. The detonation of a charge of high explosive gives rise to a high-pressure longitudinal wave of large amplitude, known as the blast wave (see Fig. 2), the peak pressure of which may be very considerable; thus, even a 1 lb (0.45 kg) charge of TNT when detonated gives an excess over atmospheric pressure of about 100 lb/in<sup>2</sup> (0.69 MN/m<sup>2</sup>) between 1.2 and 1.5 metres from the detonation. The blast wave is followed by a rarefaction, called the suction wave, which, when blast-producing munitions are employed, may do much damage to doors, windows, light partitions, etc, by drawing them towards the point of burst after the blast wave has done its damage. The damage-causing potential of the blast wave of HE bombs depends on the total positive impulse, a measure of which is provided by the area under

the positive phase of the pressure-time curve. Evidence gathered from static trials, in conjunction with observations on actual bomb damage, has enabled predictions to be made of the damage likely to be caused to buildings as a result of blast. Practically all buildings will be destroyed within an area in which the positive blast impulse exceeds 90 lb-millisecond/in<sup>2</sup> (0.62 MN-millisecond/m<sup>2</sup>) and severe damage may be expected in areas where it exceeds 40 lb-millisecond/in<sup>2</sup> (0.28 MN-millisecond/m<sup>2</sup>); these figures are taken as criteria of air-blast damage radii. In underwater explosions, because of the low compressibility of water, the shock pressures will be 100 to 200 times those in air. By adding finely-divided aluminium to explosives such as RDX/TNT and the Amatols (which thus gave rise to the Torpexes and Minols, respectively) an increase in explosives energy may be obtained together with a longer duration of blast pressure (Chapter 7), and recent work has shown that up to 20% of aluminium may be added without affecting fragmentation properties (peak pressure), while about 30% may give the best positive impulse (blast) results.

**20. Shaped charges:** Another type of store which has necessitated careful attention to the detonation as well as the filling properties of the explosive employed is the so-called 'shaped charge', 'hollow charge' or 'HEAT' weapon (see Fig. 3). It was first developed for military use in the 1939-1945 War, although the shaped-charge principle is said to have been employed in mining operations as early as 1790 and was investigated by the American explosives technologist C E Munroe in 1888, when he found that the crater formed on firing a slab of guncotton in contact with steel could be deepened if a hollow was made in the face of the slab in contact with the target. It was subsequently found that the depth of the hole could be further increased by lining the hollow in the explosive with metals. When a solid charge of HE having in one face a cavity lined with metal is detonated from the end furthest from the cavity, the lining collapses inward towards the axis of the cavity, forming a powerful jet which may be capable of penetrating thick armour or concrete. Metals of lower melting point (for example, copper, silver, aluminium, zinc and lead) produce 'fluid' jets of molten droplets, while metals of higher melting point (for example, steel) give jets of fragments. The velocity of the tip of the narrow, high-speed jet may be as high as 14000 m/sec. For a given weight of an individual explosive such as TNT, or of a homogeneous mixed explosive such as RDX/TNT, the depth of penetration of the jet increases linearly with the detonation pressure, which is roughly proportional to the square of the velocity of detonation.

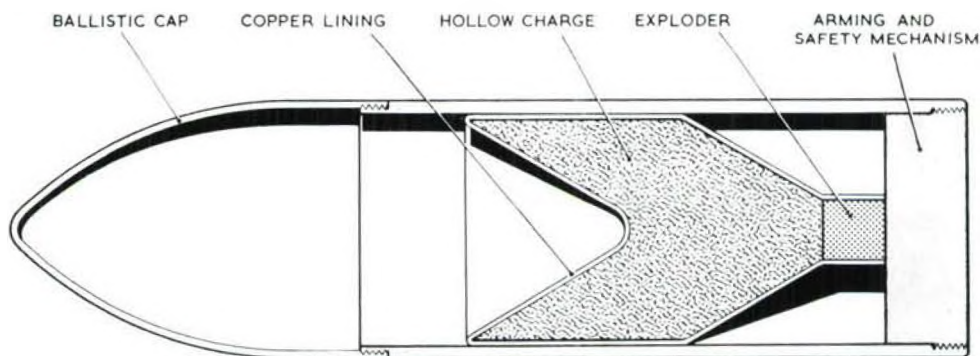

Fig. 3 A hollow-charge weapon (simplified)

**21.** As the velocity of detonation increases linearly with the density of the explosive, it is at once apparent that a hollow charge must have the highest practicable density and be composed of an explosive having the highest possible velocity of detonation. To achieve the latter quality, explosives containing high proportions of HMX or RDX are the most suitable. But the practical difficulties in filling a high-powered explosive to a sufficiently high density can be a reason for not employing it in this field; although Composition EDC 1 has a very high detonation pressure at its theoretical maximum density, it cannot be used because the high viscosity of the molten composition renders it very difficult to fill to the required density, so that it is necessary to 'dilute' it by adding 5 per cent of TNT to give Composition EDC 1A, which gives a low-viscosity mixture capable of being poured to form charges of high density. Particulate mixtures, such as the amatols and aluminized explosives, are not useful as the comparatively large particles of ammonium nitrate and aluminium do not contribute to the energy of detonation in time to influence the formation of the jet; their velocity of detonation does not, in fact, increase linearly with their density. The performance of explosives containing inert binders, for example, RDX/Wax, is dependent entirely on their density and on the percentage of explosive matter.

**22.** The cavity of a shaped charge takes the form of a surface of revolution (cone, hemisphere, spherical cup, etc), the conical shape being the most commonly employed. On detonating the charge, the jet is completely formed when the material from the front (or target end) rim of the lining meets on the

axis; the jet at this instant consists of a stream of material moving towards the target with a velocity gradient, the tip having the greatest velocity. As the jet travels forwards *en masse* it becomes drawn out, its diameter decreasing as its length extends until it becomes unstable and breaks up into drops; just before which point its penetrative power is at a maximum. Hence it may be seen that the maximum effect of a hollow charge is obtained if it can be detonated at a distance — called the 'stand off' — from the target surface. The 'stand off' is usually measured in terms of  $D$ , the front diameter of the cavity, and the optimum generally lies between  $2D$  and  $6D$ , although a high-quality charge and lining jet may persist for a distance of  $20D$  to  $30D$  in air before becoming unstable and breaking up.

**23.** When acting on materials such as steel, the jet deforms the steel plastically, pushing it away from its path to make a deep narrow hole having a diameter about 3 or 4 times that of the jet; no metal is lost from the hole, and the overall effect is similar to that produced by pushing a finger into a soft material such as butter. The depth of penetration, for a given shape of lining and type of explosive, is roughly proportional to the front diameter of the cavity. If the cavity is conical, the more acute the cone angle the deeper the penetration; but it is then more difficult to obtain a homogeneous filling, free from voids in the critical region at the base ('front') of the cone, apart from the disadvantage that a deep cone takes up space which might otherwise be filled with explosives (so that cone angles of less than  $42^\circ$  are not used in Service). It is important that filling and liner shall have a high order of axial symmetry in order to ensure the formation of a well-aligned jet having the correct velocity gradient along its lengths. In general, the depth of penetration is independent of the degree of confinement of the charge, so that other considerations enter into the decision as to the thickness of casing employed. The liner is generally of copper, but aluminium may have advantages in some instances. Because the rotation of a hollow charge imparts an angular momentum to the jet, giving it a radial spread and reducing its penetrative efficiency, shaped charges are not used in gun-fired shells. Shaped-charge weapons in British Service are normally filled with a single pour of composition EDC 1A or 60/40 RDX/TNT.

**24.** *Squash head*: A few remarks may be appropriate regarding the high explosive 'squash head' (HESH) shell because its filling calls for an explosive combining high energy with as low a sensitivity as possible. The purpose of this shell is to defeat heavy armour, but (unlike armour-piercing shell, which detonate after penetration) it is designed to detonate on impact, sending a shock wave through the plate which is thus caused to 'spall' on the other (inner) side and project lethal fragments to the inconvenience of, say, a tank crew. Thus the shell body is merely the agency for carrying the explosive and its means of detonation to the target surface, which it is not intended to penetrate. The most effective fillings for these shell are mixtures of RDX with hydrocarbon waxes, and a number of such compositions, containing 9%—14% wax, have been developed.

#### *Ease of industrial working*

**25.** The methods used for filling high explosives into shells, bombs, *etc.* are similar in principle to those used for the preparation of substances such as metals, concrete and plastics, and include casting, compression moulding, extrusion and hand-filling, with vibration as appropriate. High explosives can be drilled, turned and sawn — with suitable precautions to allow for their ignitability.

**26.** Casting, by pouring the molten explosive into the munition and allowing it to cool and solidify, is the most commonly employed method of filling. It can be applied to TNT, the high-TNT content explosives (for example, 60/40 RDX/TNT and the Torpexes) and to mixtures of RDX/Wax, *etc.* containing sufficient fusible wax. Casting is a method particularly suitable for large and medium-capacity stores (for example, bombs, torpedo warheads, depth charges, *etc.*) and for those stores in which the filling aperture is smaller than the internal cross-section of the container. All modern poured fillings are molten within the range  $80^\circ\text{C}$  to  $85^\circ\text{C}$ , and are thus capable of being melted in low-pressure steam-jacketed pans. A problem with molten explosives, however, is that they contract on cooling. Originally, this was dealt with by pouring in increments, allowing a crust to form and breaking the crust on each increment before pouring the next. An improvement to this tedious process was the 'liquid and biscuit' technique, in which precast 'biscuit' is added to an incremental pour of molten explosive in successive stages to fill the munition. This technique is not convenient for the smaller stores or for shell, and for these a moulded plastics header is used to give a single pour which draws liquid explosive from the header as the main charge cools and contracts: this process is particularly suitable for continuous-plant filling where the solidification time is comparatively short (say, 30 minutes); however, the use of steam-heated probes, or steam-jacketed headers, will extend the cooling time and control the rate of cooling if necessary. When a steam-heated header is used it is sometimes necessary to interpose a Tufnol disc or 'collar' between the header and the store to prevent undue heat-transfer.

**27.** If a 'straight' TNT filling is poured at  $100^\circ\text{C}$  and allowed to cool slowly it may form large crystals, especially in the region around the exploder container, which is normally the last to solidify; these crystals are difficult to detonate. The formation of large crystals may be avoided by the use of 'creamed' TNT, a slurry of molten TNT containing solid (flake or milled biscuit) TNT in suspension; the solid TNT provides seeds to induce the rapid formation of small crystals, resulting in high-density, high quality fillings.

28. It may be worthwhile to refer to a special problem which arose with molten RDX/TNT compositions. On safety grounds, it had always been the practice to incorporate the Amatols in steam-jacketed pans fitted with a slow-moving (15 to 25 rev/min) anchor-type stirrer having a clearance of about a  $\frac{1}{4}$  inch (6.35 mm), and this practice was adopted for RDX/TNT, which, however, tended to thicken under these conditions. It appears that the finer particles of RDX flocculate in the TNT; this increases the viscosity of the slurry, which might become unpourable. The use of additional TNT to 'thin' the slurries was undesirable, but it was found that thickening did not occur if a rapid-stirring mixer was employed (150 to 250 rev/min) having a wide clearance between the peripheral path of the stirrer and the side of the jacketed pan. At the same time, the practice was adopted of recrystallizing from cyclohexanone the RDX (hitherto only boiled in water); the resulting RDX/TNT thickened more slowly when stirred, and gave high-density (1.68 g/ml) fillings when quick-stirred.

29. Press filling, using power-operated presses, is particularly suitable for high-rate-of-flow continuous filling if the explosive can be prepared in a free-flowing granular form. A number of increments are pressed into the store at pressures of from 6 to 10 ton/in<sup>2</sup> (92.7 to 154.4 MN/m<sup>2</sup>), to ensure an adequate and uniform charge density. The method is applicable to a considerable range of small and medium calibre shell and to the manufacture of exploder pellets of tetryl or RDX/Wax, which can be turned out at a rate of 240 pellets per minute.

30. Extrusion filling can be applied to thermoplastic explosives and to compositions containing a cold-curing rubbery bonding agent. At first, a screw-filling process was used for shell to be loaded with hot plastic (non-pourable) Amatols and some other compositions; clearances between the stainless steel screw and its tube were within the range 0.003 to 0.006 inch (0.076 to 0.152 mm) on the diameter. However, the screw-filling process involves hazards, and it is no longer used. Extrusion of the hot-plastic filling into the shell under hydraulic pressure of 1 to 2 ton/in<sup>2</sup> (15.4 to 30.8 MN/m<sup>2</sup>) from a steam-jacketed cylinder (having an orifice streamlined to a diameter similar to that of the shell to be filled) has been tried but may give explosions with RDX/Wax compositions — probably due to 'hot spots' formed by adiabatic compression of entrapped air; however, the method seems suitable for compositions containing HMX or RDX and a cold-curing rubbery binder.

31. The hand-stemming process, which was used chiefly for ammonium nitrate-rich Amatols, has been improved by the use of a vibrating metal probe as used in the building industry to obtain high-density concrete.

#### *Performance and use in Service*

32. Since the 1939-1945 War, there has been a trend to replace pentolite and CE\*/TNT with RDX/TNT or TNT alone, and to discontinue the use of Minol (in common with the Amatols). But the rate of consumption of ammunition in war may be high, and a relaxation of peacetime standards may then be permissible, so that such an excellent 'emergency' filling for blast weapons as Minol could again be used.

33. In order to obtain optimum fragmentation of modern high-grade shell steels, and to avoid 'prematures' where shell are fired at the high chamber pressures now used (for example, in the Abbot gun), it is necessary that shell fillings shall be of high quality, free (as shown by radiographic examination) from cracks, voids, etc. Cavities adjacent to the wall of the shell are particularly undesirable, as any elastic deformation of the wall under firing stresses may result in adiabatic compression of air in the cavity. Similarly, any separation of the base of the filling from the shell may cause adiabatic compression of entrapped air on set-back. There has in recent times been considerable debate as to the relationship of the material used to coat the inner surface of a shell body (which, of course, must first be cleaned to an extremely high standard) to the occasional premature. The bitumen-based coatings (for example, RD 1064 and RD 1083) were, of course, valuable in covering any roughness of the metal and forming a good 'anchorage' to hot fillings. But it has lately been thought that they may flow and act as a plunger to compress entrapped air adiabatically, so that there has been a reversion to the original copal-varnish coating, in spite of its somewhat less satisfactory properties in covering roughnesses in the steel surface.

34. As regards aircraft bombs, their design and the fillings for them tended to proliferate during the 1939-1945 War to meet various 'emergencies', so that at the end of the war there were 13 types of bomb and 12 approved fillings. This situation was reviewed so that the only HE bombs in Service in 1950s were (a) the series of high speed, high-altitude, 1000 lb MC bombs, Marks 6-12, and (b) the Royal Navy 500 lb MC bomb. For all these Torpex 4B was the chosen standard peacetime filling, partly to make the best use of expensive RDX, partly because the peacetime storage properties of the Torpexes are good, and partly to take full advantage of the blast effect of an aluminized filling. Torpex 4B was also considered sufficiently insensitive to permit fuzed bombs to function adequately on striking a target after high-altitude release. Filling was done by the 'liquid and biscuit' method (para. 26).

\* Composition exploding — CE — Tetryl.

35. Explosive stores carried externally on high-speed aircraft at low altitudes are subject to aerodynamic heating which may rise the temperature of the filling above 80°C, so that the Torpexes are unsuitable for such stores. Setting aside anything which might be done to insulate the filling from the casing, it is therefore necessary to seek a heat-resistant explosive, and the choice of such an explosive is restricted on grounds of cost and of difficulties in processing and filling. RDX/Silicone Rubber is a composition of excellent stability up to 200°C, but it is too expensive for large stores. RDX/Polyurethane Rubber compositions may withstand heating at 140°C for an hour, but such compositions have only a short 'pot life' in the Filling Factory so that difficulties arise in cleaning the process plant and equipment. A solution to the problem has been found in RDX/Wax/Aluminium 2B (71/9/20 + 1 Terylene Fibre); the Terylene acts as a reinforcing agent, and the relatively small proportion of wax (although it melts in the range 78°C to 85°C) is held in the filling by capillary action and exudes only after many hours' heating. The hot composition is consolidated into the store using a vibrating probe, the fibrous filler preventing cracking during cooling. The whole of the differential contraction between the filling and the casing on cooling leads to the formation of a comparatively wide air gap which is filled by encapsulating the filling in a polyurethane rubber; this rubber is sucked into the evacuated bomb as a mixture of castor oil and tolylene di-iso-cyanate which is allowed to cure *in situ*.

36. Underwater stores (mines, torpedo warheads and depth charges) employ a filling of Torpex 2B — Torpex 2 (41/41/18:RDX/TNT/Al) desensitized with a little Wax 6. RDX/WAX/Al, 71/9/20, is being considered for the filling of new torpedoes in view of its superior temperature characteristics (and its improved blast effect).

37. Guided weapon warheads generally employ 60/40 RDX/TNT reinforced with 0.25% of ¼-inch (6.4 mm) Terylene fibres to ensure resistance to vibration stresses.

CHAPTER 14

Safety and Safety Tests

CONTENTS

	<i>Para</i>
<b>Safety</b>	
<b>Introduction</b> .....	1
<b>Explosives Safety Certificate</b> .....	4
<b>Explosives building and areas</b> .....	7
<i>Classes of buildings</i> .....	8
<i>General principles of building construction</i> .....	9
<i>Quantity distances</i> .....	19
<i>Clean areas</i> .....	23
<i>Maintenance and repair</i> .....	25
<i>First Aid requirements</i> .....	28
<b>Handling and working with explosives</b> .....	29
<i>Procedures with suspect stores</i> .....	29
<i>Disposal of waste</i> .....	32
<i>Fire and explosion risks of various explosives</i> .....	34
<i>Storage in tropical climates</i> .....	35
<i>Exudation</i> .....	39
<b>Safety tests</b>	
<b>Test Methods</b> .....	42
<i>Stability</i> .....	42
<i>Impact tests</i> .....	44
<i>Friction tests</i> .....	51
<i>Ignition temperature</i> .....	56
<i>Ease-of-ignition test</i> .....	58
<i>Electrostatic hazard testing</i> .....	62
<i>Miscellaneous sensitivity tests</i> .....	65

**Table**

<i>No</i>		<i>Page</i>
1	Principal 'risk' categories of explosives and munitions .....	9

**Illustrations**

<i>Fig</i>		
1	Rotter impact machine chamber .....	13
2	Measurement of gas in Rotter impact test .....	13
3	Charge oblique impact test .....	16
4	Spigot-test apparatus .....	18
5	Susan-test apparatus .....	19

RESTRICTED

**ANNEXE A**

**Properties of explosives and some compositions**

**ANNEXE B**

**Scheme for safety control of proposals for new work**

**ANNEXE C**

**Classification of explosives hazards**

**Table**

<i>No</i>		<i>Page</i>
C1	Comparative Table of explosive-hazard classification systems .....	34

## CHAPTER 14

## Safety and Safety Tests

## Safety

## Introduction

1. Any reader of this book is likely to have management responsibility, now or at some future time. Such responsibility extends not only to what is commonly thought of as 'labour management', 'productivity' and 'paperwork' but — and this is particularly important in the explosives field — to the safety and wellbeing of all personnel and of all persons and property in the vicinity of explosives work. Bearing in mind that 'It is the ultimate purpose of explosives to explode', every operation involving the handling or use of explosives must be carefully planned so that it can be executed safely. If it is to be a repetitive, or 'production line', operation it should be carefully defined and written in a 'process manual' and the management staff should regard it as a prime responsibility to ensure by constant supervision that no unauthorized departure from such a manual takes place. In these days it will rarely be necessary for such planning to be an individual responsibility; not only will there be experienced colleagues with whom a proposed new operation can be discussed, but, at both Departmental and Establishment level, there are Safety Officers whose advice should be sought. A useful set of planning documents, developed in the Explosives Research and Development Establishment, is annexed to this Chapter to give some guidance to readers.

2. In Crown establishments the provisions of the Factories Acts and of the Explosives Acts are not legally binding, but it is the practice to operate in full conformity with them and with the provisions of any Regulations made under those Acts, and if it appears that any departure from such provisions will be necessitated by special circumstances the advice of the appropriate Safety Officer should at once be sought. Whilst it is well to have a knowledge of the Acts and of Regulations made under them, their principal requirements are embodied in the Departmental Safety Regulations and Explosives Regulations. Establishment Safety Rules apply to the particular operations carried out at the workplace(s) for which the rules have been drawn up.

3. There are a few general rules which should be observed when working with explosives:

- (1) explosives should never be subjected to blows or to friction. Thus they should not be stored in bottles with ground-glass stoppers, and no attempt should be made to move a screw thread which is, or may be, contaminated with explosive until the thread has been well permeated by 'penetrating oil' and any visible explosive removed by the use of a suitable solvent
- (2) explosives should be carefully guarded against contamination by foreign matter, which may cause chemical degradation or, especially if gritty, may cause an increase of sensitiveness. Under normal circumstances water should be regarded as such a contaminant, for it will react with some explosives and will degrade the performance of most of them
- (3) explosives should not be exposed to sunlight, or to other actinic radiation which may cause degradation — perhaps resulting in inflammation. Long-term storage should be in the dark
- (4) explosives should be stored in a cool place and should never be subjected to any unnecessarily high temperature which, even if it does not cause ignition, may impair chemical stability. Double-base propellants and explosives containing nitroglycerine should not be subjected to temperatures below 10°C, to avoid the 'freezing' of the nitroglycerine. Optimum storage temperatures are from 15°C to 20°C.

## Explosives safety certificate

4. Obviously, the safe handling of explosives is largely dependent on a thorough knowledge of their reaction to the conditions they are likely to encounter during their storage, processing, filling and disposal. To ensure the proper transmission of such information to the relevant staffs it has been the practice for the R and D authorities to prepare for each Service explosive a Safety Certificate, which is issued under the authority of the Director of the Royal Armament Research and Development Establishment or of the Director of the Explosives Research and Development Establishment, both in the Ministry of Defence; in either instance the Certificate is 'approved for issue' by the appropriate Chief Safety Officer.

5. If during the development of a new explosive or explosive composition quantities of it must be furnished to a second party (for example, an ROF asked to do experimental fillings) a 'provisional' Safety Certificate, embodying all known information, should be provided under the authority of a responsible officer concerned with the development; such a Certificate is valid for 12 months only. A specimen Safety Certificate (using a particular cordite as an example) together with the notes on its clauses is given in the following pages (page 4 to 7).

**EXPLOSIVES SAFETY CERTIFICATE**

No. \_\_\_\_\_

THIS CERTIFICATE describes those properties of the material specified in Clause 1 which are important for the safety of its manufacture, handling, filling and disposal. The responsibility for the safety of all operations involving the material described in this certificate remains with the user. The results reported present a summary of the available information regarding hazards likely to arise.

**AUTHORITY FOR CERTIFICATE**

I, the undersigned, CERTIFY that this material has been subjected to tests as stated in this certificate and has given the results recorded.

REFERENCE

Date

for Director  
ERDE

**APPROVED FOR ISSUE**

DIRECTOR OF SAFETY (AD)  
MINISTRY OF DEFENCE  
Date

CHIEF SAFETY OFFICER  
MINISTRY OF TECHNOLOGY  
Date

**NOTE ON STORAGE AND TRANSPORT**

Classification entries at Clause 2 b, c, d and e relate to the explosive in bulk form in approved packages. This is a provisional classification only. The explosives may not be transported outside the establishment, except "under control", until formally classified by the E.S.T.C. For classification of the subject material when filled into Service Stores see an Explosives Classification List published by the E.S.T.C.

**RECORD OF AMENDMENTS** to Safety Certificate No.

Amendment slips should be affixed to this sheet.

RESTRICTED

**CLAUSE 1 DESIGNATION AND NOTEWORTHY CHARACTERISTICS**

CORDITE F565/55  
PROPELLANT WITH FIRE RISK

**COMPOSITION**

NITROCELLULOSE, WOOD 12.2%, N <sub>2</sub>	52.5
NITROGLYCERINE	34.0
DIBUTYL PHTHALATE	2.5
CARBAMITE	3.5
WAX	0.075
DNT	7.5
LEAD STEARATE	2.0

**CLAUSE 2 CLASSIFICATION**

<i>a</i> SENSITIVITY	SENSITIVE
<i>b</i> STORAGE & TRANSPORT	3
<i>c</i> QUANTITY DISTANCE	Y
<i>d</i> FIRE FIGHTING	2
<i>e</i> TYPE (for SR. & PN. compositions only)	

Sensitivity classification is based on the results given in Clauses 3, 4 and 8

**CLAUSE 3 SENSITIVENESS TO DIRECT MECHANICAL SHOCK**

Figure of insensitiveness (against RDX = 80) is 20

**CLAUSE 4 SENSITIVENESS TO FRICTION** Expressed as percentages

Anvil	Mallet	
	Boxwood	Mild Steel
Cement	—	—
York Stone	0%	—
Hardwood	0%	—
Softwood	0%	—
Mild Steel	—	50%
Naval Brass	—	50%
Aluminium Bronze	—	50%

**CLAUSE 5 TEMPERATURE OF IGNITION**

171 Degrees Celsius

**CLAUSE 6 IGNITION BY FLASH**

IGNITES AND BURNS QUIETLY

**CLAUSE 7 BEHAVIOUR ON INFLAMMATION**

IGNITES AND SUPPORTS TRAIN STEADILY THROUGHOUT

**CLAUSE 8 IGNITION BY ELECTRIC SPARK**

NO IGNITIONS at 4-5 JOULES

**CLAUSE 9 CHEMICAL STABILITY**

SATISFACTORY

**CLAUSE 10 INCOMPATIBILITY WITH OTHER MATERIALS**

AMMONIA, STRONG AMINES, NITROPHENOLS, SULPHUR, GUNPOWDER AND MIXTURES CONTAINING SULPHUR

to be avoided except in authorised mixture under regulated conditions

**CLAUSE 11 PROCESS MATERIALS**

Containers

Hand Tools

Other Tools

NORMAL FOR SOLVENTLESS CORDITE

**CLAUSE 12 HEALTH HAZARDS**

Class III

TECHNICAL AND MEDICAL MEMORANDA NOS 18, 19 AND 36 APPLY.  
LEAD STEARATE IS TOXIC. REGULAR MEDICAL SUPERVISION REQUIRED.

**CLAUSE 13 RECOMMENDED METHOD OF DESTRUCTION**

BURNING WELL SPREAD. NOT MORE THAN 3 INCHES DEEP. QUANTITY NOT EXCEEDING 500 lb AT ONE TIME. AVOID INHALATION OF SMOKE WHICH WILL CONTAIN TOXIC LEAD COMPOUNDS.

**CLAUSE 14 FIRE EXTINGUISHING AGENT**

WATER

**CLAUSE 15 MANUFACTURING HAZARDS AND ADVICE**

MANUFACTURE BY NORMAL PROCESSES FOR SOLVENTLESS CORDITE

**CLAUSE 16 ADDITIONAL INFORMATION**

6. The chemical tests required to provide information on stability, *etc.* for the Safety Certificate are outlined in Chapter 15. An account of the tests to assess sensitiveness to physical and electrical stimuli is given in para. 42 *et seq* of this Chapter.

#### **Explosives buildings and areas**

7. The design of the equipment employed in the manufacture and processing of explosives is, of course, a vital element in safety of operation; it will take into account all the information contained in the Safety Certificate as well as general principles of safe engineering and chemical engineering design. No less important is the design and disposition of the buildings in which explosives are manufactured, processed and stored, and a brief account will now be given of some general principles governing the nature and maintenance of such buildings and their staffing.

#### *Classes of buildings*

8. Explosives buildings may be broadly divided into two classes:

- (1) buildings in which the manufacture of some explosive or the assembly of explosive stores is carried on
- (2) magazines or buildings in which explosives are stored.

#### *General principles of building construction*

9. There is, in fact, more risk of explosion in manufacturing and assembly buildings than in magazines, and so care should be taken to ensure that the effects of explosion are confined to the particular building in which it occurs and not transmitted to its neighbours. Such buildings should be of as light construction as possible so that large masses of material cannot be projected; particular care should be taken to avoid, if at all possible, the presence of heavy items (for example, crane gantries, large girders, *etc.*) high in the building. Walls and roof should preferably be of light, frangible, fire-resistant materials.

10. The nature of the flooring materials will depend markedly on the work to be done in the building. In the actual manufacture of explosives it is usual to employ floors of acid-resisting brick set in an acid-resisting cement, and such floors are often used in those houses in which explosives are purified by recrystallization from solvents; but such floors must be kept wet, to minimize frictional risks. In buildings in which 'dry' processes are carried on it is more usual to use a bituminous floor which should, where 'static' electrical hazards could occur, be electrically conducting (though not too highly conducting, to avoid danger to electricians who may be called in to do maintenance work). In the manufacture, washing and dispensing of nitro-glycerine it has been customary to use dish-like floors of lead sheeting, joined by 'burning', so that accidental spillages were contained; but the development of the more advanced continuous NG processes may render this a less important consideration.

11. The interior of explosives buildings should be so designed as to avoid the presence of cracks and crevices in which explosive material may lodge. All doors and emergency exits should open outwards and should be sited on the lines of exit which workers would be most likely to take in emergency.

12. Wood should not be employed as a constructional material in any building in which oxidizing substances (for example, nitric or 'mineral' acids, nitrates and perchlorates) are employed or stored, since such substances in contact with wood may give rise to fierce fires.

13. Ironwork should be kept well painted, but aluminium paint should not be used on it, since if struck accidentally with a tool it may give rise to a hot spark (aluminium and iron oxide may combine with liberation of heat).

14. Nails and screws used in 'dry' process buildings should preferably be of copper or brass (but workshops where lead azide is present are an exception). Iron or steel nails and screws, if used, should be countersunk and covered with a putty-like composition.

15. Suitable plastics are generally preferable to glass for windows, but if glass must be used it should be of the wired variety to minimize risk of dispersal of splinters if it is struck a blow. Wired-glass rooflights are undesirable — a small explosion may cause a heavy sheet to fall into the building and in a serious explosion such sheets are dangerous missiles. Windows should be so sited that direct sunlight does not fall on explosives, or should be of non-actinic material or even be lightly painted.

16. It used to be important that paints used in explosives buildings should be 'lead-free', but as picric acid is not now in Service use, and as lead-free paints (based on titanium dioxide or zinc oxide) are now in ready supply, it is currently and normally less important to specify lead-freedom, except where ammonium picrate is being processed.

17. Electrical equipment for explosives buildings should be 'dust- and water-proof'. It is not often necessary, or even desirable, to specify 'flame-proof' equipment. Switches and all other such items in

which a spark might occur should be mounted outside the building, and main isolators should be some distance away so that they can be pulled in an emergency by operatives who have left the building. Wandering flexible leads are not permissible in an explosives building, and any portable source of light required should be of approved low-voltage battery type.

18. Obviously explosives buildings must be protected against lightning. This can be done by:
- (1) a well-earthed metal mast (or masts), that provides a cone (or cones) of protection sufficient to enclose extremities of the building
  - (2) a wire catenary supported by masts to give a zone of protection sufficient to enclose a building or group of buildings
  - (3) a Faraday Cage on the roof of the building, comprising a lattice of conducting strip bounded by and bonded to a strip around the roof periphery at a point immediately above the buried electrode.

In all systems the base of the building is surrounded by a well-earthed ring to which down-conductors from the upper elements are bonded. All metal structures and equipment within the building are connected to this earthed ring.

The zone of protection in (1) and (2) and mast heights depend on the class of protection required which is related to the nature of the explosives involved.

Detailed information is given in British Standard Code of Practice CP 326 and the Procurement Executive, Ministry of Defence, Controller of Royal Ordnance Factories Code of Practice No. 5.

*Quantity distances*

19. In order to limit the damage resulting from an explosion, explosives buildings must be separated from other buildings and from public railways and highways by specified distances (known as 'Quantity Distances') which depend on the nature and quantity of the explosives which may be present in them. These Quantity Distances are based on the recommendations of the Inter-Departmental Explosives Storage and Transport Committee (ESTC).

20. Two classes of quantity distances are defined as follows:
- (1) 'inside' distances, which must separate buildings within an Establishment and are mainly for the prevention of propagation of explosion from building to building or for the prevention of injury to occupants of main workshops, offices and the like
  - (2) 'outside' distances, which must separate the buildings from privately-owned inhabited buildings, public highways, etc, outside the establishment, and which are naturally much greater than the 'inside' distances.

21. Sets of distances are laid down in Explosives Regulations and other documents for each of the principal categories of explosives and munitions (see also Chapter 3) according to the nature of risk which they present.

**Table 1**

**Principal 'risk' categories of explosives and munitions\***

Category	Fire risk	Intensity of explosion	Missile risk	Examples
X	Not mass fire	Slight and local	Some risk of projection	SA cartridges, fuzes, AP shell, gaines and igniters, and some HE rounds and shell
Y	Mass fire	Minor but not mass explosion		Cordite and cordite cartridges
Z		Mass explosion	Serious	High-charge HE shells and bombs
ZZ		Mass explosion	Minor	HE in bulk (4080 kg or more)

22. For quantities exceeding 4000 kg outside distances are the same whether or not the building is traversed (that is mounded or otherwise protected, for example, by a blast wall) but inside distances may be reduced if the building is surrounded by an approved type of traverse.

\*See Annexe C to this Chapter for a comparison of United Kingdom and other systems of classification

*'Clean' areas*

23. The buildings in which explosives are handled or stored, and sometimes their approaches, are regarded in whole or in part as 'clean' areas, in each of which the number of persons and the quantity of explosives allowed to be present are defined. Such clean areas are marked at their entrances, either by low red-painted barrier boards or by red lines on the floor. The regular employees must wear clean approved clothing and boots or shoes, and all personnel entering such a clean area are required to wear either approved footwear or overshoes. In routine processes the materials, tools and equipment which may be present in a clean area are defined and nothing which is not in the defined list is allowed to enter — particularly, of course, smoking materials, and means of ignition. In laboratories in which explosives are handled, appropriate rules on similar lines should be made and enforced.

24. Reference was made in para. 10 to 'static' hazards in relation to the nature of flooring to be used in certain clean areas. Such hazards may arise from operations such as sieving, pouring and mixing and can be particularly dangerous when the substances involved are dry nitrocellulose, nitrocellulose ('single base') powders and primary explosives; they may also arise from the movement of personnel who, especially in conditions of low relative humidity, can accumulate considerable charges on themselves. Where risks may arise, all equipment and personnel must be properly earthed, the humidity must be raised, a floor and shoes of conducting type employed and a 'personnel earthing technique' (with test meter) provided in the clean area, preferably at the entrance to the workroom.

*Maintenance and repair*

25. The maintenance and repair of 'danger buildings' calls for comment. Cleaning materials and equipment to be used in danger buildings must be carefully considered as to suitability and quantity. Plastics buckets are usually preferably to metal ones; alkaline soaps should be avoided as being reactive with many explosives; flammable solvents should not be used if non-flammable ones will serve (and great care should be exercised to ensure thorough ventilation when any solvents are used); cleaning rags must never be allowed to remain in workrooms (when dirty they are liable to spontaneous ignition).

26. Before any repairs are carried out on a danger building (except for minor repairs to the exterior) all explosives must be removed and the whole building thoroughly cleaned and inspected, paying special attention to all places (hidden spaces, ledges, corners, crevices and drains) where any explosive material may have lodged. The building should then be certified 'clean' to the staff responsible for the repair work.

27. From time to time buildings should be carefully examined to ascertain whether any parts of them (especially floors) have become impregnated with explosive, in which event such parts must be removed and reconstructed with new materials.

*First-Aid requirements*

28. The Factories Acts and the Explosives Regulations lay down certain minimum requirements for the provision of First-Aid materials for men in workplaces. Obviously these requirements must be provided, and carefully maintained, in any Establishment dealing with explosives. But there may be additional requirements (for example, breathing equipment in buildings where acids are handled, or protective creams where substances likely to cause dermatitis are in use), and these should be provided in consultation with the appropriate Safety and Medical authorities, who should also arrange that adequate arrangements are made to deal with the consequences of any serious accidents.

**Handling and working with explosives***Procedures with suspect stores*

29. The handling of properly labelled explosives (for example, TNT, tetryl, RDX, nitrocellulose, nitroglycerine, cordite) will usually be done with a regard for safety, although management staff must be constantly vigilant against 'familiarity breeding contempt' as well as against sheer carelessness. If such explosives have been obtained from Service stocks their original quality will have been certified by the Directorate of Quality Assurance (Materials), DQA(Mats), formerly known as the Directorate of Chemical Inspection, (DCI), but care will be called for if there is any evident sign of deterioration (for example, by reason of age or contamination with foreign matter) in which event they should be set aside in a safe place until they can be reinspected and arrangements made for their safe disposal.

30. Unlabelled materials or other potentially dangerous substances (for example, building materials or dusts which may be contaminated with explosives) should be subjected to the following two simple tests (at a distance from the bulk of material!) before any decision as to further work on them is taken:

- (1) place a few milligrammes of the material on a metal spatula which is then held in a flame. A sharp deflagration indicates the presence of explosive matter. (Goggles should be worn for this test.)

(2) place a few milligrammes of the material on a flat steel surface and strike it a glancing blow with an ordinary 1-2 lb hammer. A sharp 'cracking' noise indicates the presence of explosive matter of some sensitivity. If the first trial is negative it should be repeated several times before it is concluded that the material is not particularly sensitive.

**31.** Any mixture of a combustible material with an oxidizing material should be regarded as potentially explosive, subjected to the tests in para. 30 and treated accordingly.

#### *Disposal of waste*

**32.** In process work, safety measures and action to be taken with 'waste' explosives are defined as part of the process instructions. In laboratory work, however, these matters must be thought out for each operation. A primary safety consideration is to work with the smallest practicable quantity of any explosive or potentially explosive substance and, if possible, to carry out the work behind a suitable screen or barrier. Screens of sizes suitable for operations involving 5 g to 50 g of explosive have been designed and only such approved screens should be used, and then only if the explosive is lightly confined (for example, in laboratory glassware); even so, it must not be forgotten that explosion of several grammes of material may damage the ear-drums, and approved ear-guards should be worn. The processing of any quantity of explosive larger than 50 g calls for the consideration of massive protection, for example, a reinforced brick or concrete wall, armourplate or a properly designed cell or bunker. Even when working with quite small quantities, say up to a gramme, it is wise to wear an approved face-mask of transparent plastics material and, if possible, strong gloves. In laboratories, waste explosives and materials contaminated with explosives should be placed in covered plastics buckets containing just enough water to cover the waste; separate buckets should be used for HEs and propellants and the buckets should be collected regularly for removal to the burning ground; waste primary explosives (initiator explosives, etc) must receive appropriate chemical treatment to ensure their degradation before any residual matter is disposed of in appropriate manner.

**33.** In the larger Establishments the disposal of waste explosives by burning is undertaken by trained staff. It is done by spreading the waste thinly in large shallow iron trays placed in the middle of a remote and well-cleared area of ground and igniting the waste by a train of cordite laid upwind. Some HEs would burn too violently if ignited alone, and it may be convenient to cover them with oil; this is the reason for keeping HE and propellant wastes separate.

#### *Fire and explosion risks of various explosives*

**34.** The remarks in the preceding paragraphs lead to consideration of the fire and explosion risks presented by different types of explosives:

(1) *Propellants.* In general, the cordite types of propellant, when lightly confined (for example, in wooden transport cases), present only a fire risk; but under confinement (for example, in a ship's or an underground magazine) they may produce violent disruptive effects. Cordite will not detonate unless subjected to a powerful HE impulse, but nitrocellulose powders are liable to burn to detonation if ignited in a large mass and therefore should not be stored in depths of more than about 2 ft (0.6 metres). The more modern high-energy propellants may more readily burn to produce disruptive effects, and the casting powders employed in the production of composite-modified cast double base propellants (Chapter 8) will burn to detonation in depths exceeding 4 or 5 inches (about 100 mm), so that special arrangements have had to be devised for their packing and transport. The products of combustion of propellants usually contain gases such as carbon monoxide, hydrogen and methane, which give rise to secondary explosions on admixture with air.

(2) *High explosives.* Although large quantities of TNT, tetryl and ammonium picrate have been known to burn away without explosion, it can usually be taken that HEs will burn to detonation in depths of only a few inches, and blasting explosives containing nitroglycerine will almost invariably do so.

(3) *Pyrotechnic compositions.* Many pyrotechnic compositions, especially those containing finely-divided magnesium, will burn to violent explosion in loose condition in heaps of from 4.5 kg to 9.0 kg. The recently developed rubbery compositions will be more difficult to ignite and should be less violent, even before consolidation. As with propellants, much depends on the degree of subdivision and, hence, the surface area exposed to ignition.

(4) *Primary explosives.* As might be expected, the primary explosives and compositions containing them burn to detonation when only small sources of ignition are presented to them and when they are themselves present in only the smallest quantity. For this reason only the minimum amount of material required for the work should be present.

#### *Storage in tropical climates*

**35.** Some general remarks on the storage of explosives were given in para. 3, but it remains to consider storage in tropical climates where, apart from high temperatures, there may be high humidity and wide diurnal temperature variations. Storage is considered to be 'tropical' when the average daily temperature throughout the year exceeds 30°C, accompanied by high relative humidity.

## RESTRICTED

36. Both heat and moisture are detrimental to the stability of many explosives. Permanent storage buildings should therefore be of solid construction and well covered with earth so that their internal temperature does not vary significantly throughout the 24 hours, thus minimizing the 'breathing' of the stores contained in them and thereby reducing the risk of condensation of water in such stores; ventilation of such buildings should take place only when the outside temperature is at its lowest, that is at night or in the very early morning.

37. If permanent storage is not available, explosives and munitions must at least be stored in shaded and ventilated conditions. If a tarpaulin is used it should not just be thrown over the stores but supported above them so as to give maximum shade and adequate ventilation.

38. Containers and uncrated munitions which may be subjected to solar radiation should be painted in the lightest practicable colours, whereby the internal temperatures may be kept some 11°C below the level they might reach if dark colours are used.

### *Exudation*

39. A safety problem which may occasionally be met within Service life is that of 'exudations' (see index). In practice, this is confined to two broad types of explosive store, those containing TNT or a TNT composition and those containing cordite or other composition based on nitroglycerine.

40. The already fairly low melting point (80°C) of TNT will be depressed by the presence of anything which is soluble in TNT, for example, TNT isomers (Chapter 6), tetryl, RDX, PETN and adventitious organic impurities. Care is taken during the manufacture of TNT to remove the isomers; TNT-tetryl compositions are rarely used because of the well-recognised low melting point (67°C) of the eutectic mixture: RDX and PETN are not very soluble in TNT and will depress the melting point of pure TNT by only about 5°C. The chief problem therefore arises from adventitious impurities. In the early amatols (Chapter 7) the ammonium nitrate then available was made from gasworks ammonia and contained traces of organic bases (for example, pyridine) which were soluble in TNT and which reacted with it to produce compounds which depressed the melting point still further; this problem, however, disappeared with the introduction of synthetic ammonium nitrate. Nowadays, almost the only risk of contamination of TNT and TNT-based fillings is from the accidental presence of solvent from varnishes and sealing compositions. A TNT exudation will appear (usually on the outside of a munition store) as a slightly greasy semi-solid which has apparently 'flowed' from a joint. A small quantity of it should be removed carefully and subjected to the simple tests mentioned in para. 30; if these show that the material is, in fact, explosive the remainder of the exudation should be removed using rags or cotton waste wetted with a solvent (xylene, for preference, but methylated spirit or carbon tetrachloride will serve), and the joint treated with a penetrating oil before arrangements are made to open it under proper precautions or to remove the store to a safe place where it can be detonated.

41. In compositions containing nitroglycerine the exudation problem is often also characterized as 'sweating'. Below 13°C (56°F) pure nitroglycerine freezes, given time. It has, however, a marked tendency to remain supercooled, a tendency which is accentuated if it is in solid solution with nitrocellulose, as in cordite and blasting gelatine. When it does freeze, crystals of NG tend to become separated from the colloid matrix and, on thawing, those on the surface melt to leave oily drops of 'sweat' which, if not present in too great amount, will be reabsorbed if the temperature remains above the melting point. But there is always the possibility of irregular reabsorption and of the absorption of NG by contiguous materials, with possible danger. The early cordites were fairly prone to this phenomenon (Cordite Mark I was liable to exude below 8°C, 45°F), but the modern cordites containing carbamate stabilizer are considered safe if stored above 0°C (32°F). Again, the explosive nature of any apparent exudation can be checked by the simple tests referred to in para. 30.

## Safety tests

### Test methods

#### *Stability*

42. The original chemical stability of Service explosives will have been established by tests to be described in Chapter 15, and that of 'aged' Service explosives can be checked by such tests as are suitable. In the laboratory, following the tests mentioned in para. 30, early action should be taken to apply to experimental explosives (whether new individual substances or new compositions) appropriate tests of chemical stability after making a thorough search of the literature for any information as to the stability and sensitiveness of those and analogous materials.

43. But because any work with an explosive involves the question of its sensitiveness to mechanical shock or to thermal or electrical impulses a good deal of effort has been devoted to devising reproducible test methods for measuring such sensitiveness, and some of these will now be considered. (A compilation, 'Manual of Tests: SCC No. 3', of sensitiveness and hazard tests has been prepared and issued by a joint Sensitiveness Collaboration Committee.)

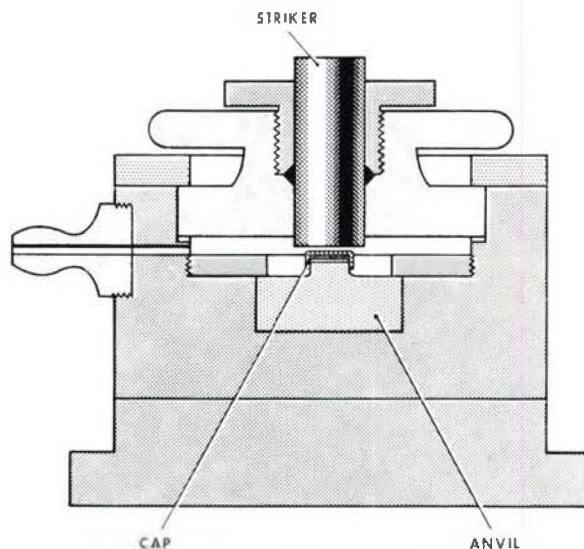

Fig. 1 Rotter impact machine chamber

*Impact tests*

44. Pure impact devoid of any element of friction is not practicable. In this country the equipment used to make measurements of sensitiveness to impact is the Impact Machine (sometimes known as the Falling, or Drop Weight machine) devised by the late Dr G. Rotter in the former Research Department, Woolwich. A volumetrically measured quantity (about 30 mg) of the explosive under test is transferred into a small shallow cylindrical brass cap which is then inverted over a steel 'anvil'; the anvil has a short cylindrical upstand which is a sliding fit in the cap. Anvil and cap are then placed in a gas-tight steel box having a glanded opening in the top through which passes a short drift that sits lightly on the inverted cap. The whole system is then positioned under a weight (5 kg) held at a known distance above the drift by an electromagnet. (See Fig. 1 and 2.) The steel box is connected to a gas measuring burette containing coloured water or paraffin. When the weight is released to fall between vertical guides on to the drift the explosive may, or may not, ignite, in whole or in part.

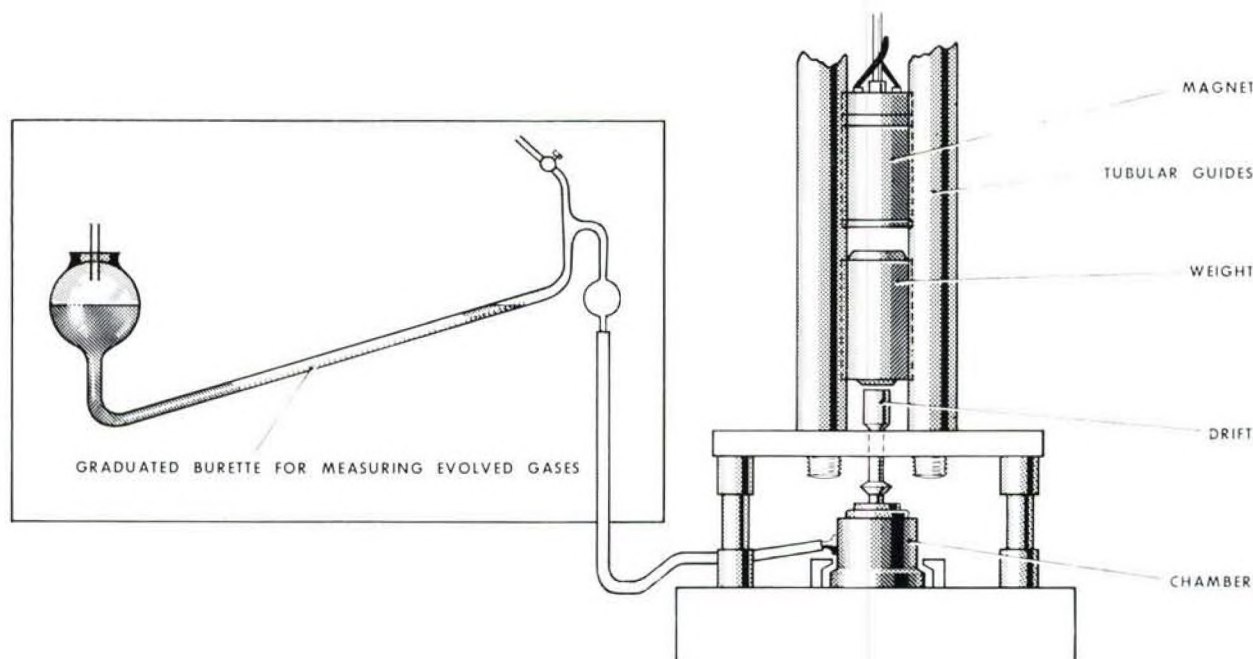

Fig. 2 Measurement of gas in Rotter impact test

45. In the present method of carrying out the test a statistical approach is employed to compare the median drop height of the explosive under test with that of a specially prepared RDX (designated 'standard RDX'). This median drop height is the height at which 50 per cent of the samples will ignite, and is obtained by the Brucceton 'staircase' or 'up and down' method. A set of fall heights on a logarithmic scale is used, and when an ignition occurs at the selected height of fall the next height to be chosen is one level down, whereas if an ignition is not obtained the next height chosen is one level up. This is continued, firing caps of the unknown and caps of the standard alternately until a suitable number (typically 200) of each are fired. The criterion of ignition is the evolution of 1 ml or more of gas as measured on the burette.

46. From these sets of trials it is comparatively easy to calculate the median height for the standard,  $H_s$ , and the median height for the unknown,  $H_u$ . The 'standard RDX' is assigned a Figure of Insensitiveness of 80 whence

$$\text{the F of I of the unknown is } \frac{H_u}{H_s} \times 80 \quad \text{---(1)}$$

It will be noted that the figure characteristic of the explosive under test is so calculated as to become smaller the more sensitive the explosive, and is thus not a 'figure of sensitiveness'.

47. In the original method of carrying out the Rotter Test, four caps were struck at each of a series of heights of fall and the total gas liberated was noted as a percentage of the total which would have been liberated had each cap given a 'complete' explosion. The percentage of gas was then plotted against the drop heights, and from the areas enclosed by these curves it was possible to calculate the average height of fall giving 50 per cent of explosions. For high explosives the standard was picric acid, assigned an F of I of 100, and for initiatory explosives the standard was mercury fulminate, assigned an F of I of 10.

48. When considering the results of such impact tests, regard must be given to the fact that the test can be done only on explosives in a reasonably subdivided form and to the fact that the effect of a blow is in some degree dependent on the physical properties of the material struck. For these reasons, propellants which are relatively soft and generally regarded as very safe to handle may give quite low F of I results, the practical significance of which is merely that any dust or small particles of them may be dangerous and should not be allowed to accumulate in workplaces. On the other hand, liquid explosives tested by the Rotter method sometimes appear less sensitive than would be expected from general experience, while the test results are generally less reproducible than with solid explosives. Work done on nitroglycerine by Bowden in the Second World War showed that its sensitiveness is in practice associated with the presence in it of trapped air bubbles, and it is now generally believed that accidental initiation of liquid explosives is frequently the result of sudden (adiabatic) compression of trapped air or vapour bubbles. Accordingly, such liquid explosives are now tested by a modified Rotter test in which a small quantity of the liquid is contained within a rubber O-ring set in a small cylindrical cavity in a hardened tool-steel anvil and a thin stainless steel disc is placed over the ring, thus trapping some air. The impact of the falling weight of the Rotter machine is transmitted to the stainless-steel disc through a drift, a steel ball and a plunger. Results are expressed as calculated median heights and some typical heights are:

Explosive	Median Height (cm)
Glycerol Trinitrate (NG)	3.8
Diethyleneglycol Dinitrate (DEGDN)	30
75% NG/25% Triacetin	33
Ethyl Nitrate	44
Triethyleneglycol Dinitrate (TEGDN)	66
Isopropyl Nitrate (IPN)	87
Nitromethane	89

49. In the United States, two types of falling-weight impact machine are commonly used, each of which employs a 2 kg falling weight. A steel cap filled with explosive and covered with a brass disc is used on the Picatinny Arsenal machine: 0.02 g of explosive is placed directly on a hardened-steel anvil under a drift at the Bureau of Mines, Brucceton. Neither machine is designed to measure the quantity of gas evolved by a sample of explosive. In the United States Ordnance Laboratory an impact test is employed in which the anvil is covered with a specific type of sandpaper; it is considered that grit is ubiquitous and therefore a meaningful test must allow for its presence. The test is now widely accepted in the United States, but gives results which cannot readily be compared with those of the Rotter-type machine.

50. The common initiatory substances have Rotter test F of I values between about 6 and 30. A more discriminating test was required for them, and one has been developed in the form of the Ball and Disc Test. In this test a small quantity of the explosive is placed on an anvil which is an up-ended  $\frac{1}{4}$  inch steel bearing roller; the explosive is covered with a thin brass disc and a light pressure (1 kg) applied to the

latter to consolidate the material. A striker having a  $\frac{3}{8}$  inch steel ball at its lower end is placed on the disc and struck by a  $1\frac{1}{2}$  inch steel ball (95 g) released at a known height. There is no doubt whether or not an ignition has occurred since there is either an audible report or a very rapid burning coupled usually with appreciable damage to the brass disc. The results are quoted as the percentage of ignitions in 50 trials at each of various heights of fall of the impacting ball. Whereas Service lead azide will give only 2% ignitions at 12 cm fall, rising to over 70% at 20 cm; if mixed with 5% carborundum powder it will give 16% ignitions at 2 cm fall. On the other hand, dextrinated lead azide gives 4% ignitions at 8 cm, rising to 90% at 14 cm, but if contaminated with 5% carborundum it gives 6% ignitions at 4 cm. Such differentiations would not easily be made using the Rotter machine. An explosive which, in the ball and disc test, gives one ignition in 50 trials with heights of fall of 4 cm or less is regarded as particularly sensitive; besides lead azide/carborundum, L Mixture falls in this class, giving 38% ignitions at 3 cm height of fall.

#### *Friction tests*

**51.** It was appreciated at an early stage in the development of explosives technology that friction was a prime cause of accidents, but it was not easy to devise a friction test capable of giving highly reproducible results.

**52.** The basic purpose of the Mallet Friction Test, which is employed for Safety Certificate purposes, is to classify explosives into three main groups: 'very sensitive', 'sensitive' and 'comparatively insensitive', and this is achieved by the use of 'anvils' of three kinds: softwood, hardwood and York stone. A small quantity (about 0.15 g) of the explosive under test is spread on the anvil to give a trace about  $\frac{1}{4}$  inch (12.7 mm) long and  $\frac{1}{4}$  inch (6.4 mm) wide and struck a glancing blow with a boxwood mallet. Owing to the somewhat variable results obtained, the tests are reported as follows:

0 ignitions out of 10 tests	0%
Up to 6 ignitions out of 10 tests	50%
More than 6 ignitions out of 10 tests	100%

**53.** Tests are now also done with a mild-steel mallet on anvils of mild steel, Naval brass and aluminium bronze. Materials which give some ignitions with a boxwood mallet and a softwood anvil and which have an F of I of 30 or less are classified as 'very sensitive'; those which do not give any ignitions with a boxwood mallet and have an F of I of greater than 90 are regarded as 'comparatively insensitive'. In some instances the test results must be interpreted with special caution; thus, in the tests using anvils of wood, compositions containing oxidants may be expected to give reactions between the oxidant and the wood which may exaggerate the apparent sensitiveness of the composition.

**54.** Various attempts have been made to render friction tests less subjective. To this end Messrs ICI (Nobel) Ltd have employed a test in which a 'torpedo'-shaped mass of appropriate material (non-metallic or metallic) slides down an inclined chute onto a sample of explosive placed on an appropriate anvil. There is also a Friction Machine in which the sample of explosive is placed between the surfaces of two 'sliding blocks' of materials which are lightly clamped together before one of them is struck a controlled end-on blow which produces a short frictional movement; this test would appear to have the advantage that the small sample of explosive is not disturbed by the 'wind' of an approaching moving mallet or other such body, but it may consume a lot of blocks. In the United States is used a 20 kg pendulum with an inter-changeable face of steel or compressed-fibre composition sweeping across a grooved-steel friction anvil.

**55.** Like the impact tests, the foregoing friction tests (paras 51 to 54) require that test samples shall be in a subdivided state. But in practice the risk arises of a large piece of explosive being dropped onto a rough surface. To assess this hazard, the Atomic Weapons Research Establishment developed a 'Charge Oblique Impact Test' (Fig. 3) in which a suitably mounted section of explosive from a solid hemisphere of explosive (weight about 45  $\frac{1}{2}$  lb, 20.6 kg) is swung at the end of a pendulum to make grazing contact with a standard simulated concrete surface (of specially purified and graded sand bonded by a thin layer of Araldite cement onto a  $\frac{1}{8}$  inch (1.6 mm) steel plate secured by a concrete slab). In the standard test the angle of swing is 45°, but the less sensitive explosives can be tested at more severe angles. The drop height scale is 1, 2, 3, 5 and 10 feet, and the results recorded are that height at which three 'fails' are obtained, and that next height at which some assessed degree of explosive reaction is recorded by a high-speed cine-camera (3000-6000 frames per second).

#### *Ignition temperature*

**56.** Apart from the effect of increased temperature in increasing somewhat the sensitiveness of explosives there will usually be a point at which it will induce ignition, and the temperature of ignition must be recorded on the Safety Certificate for each explosive substance. This temperature is measured on samples of 0.2 g explosive (0.05 g if an initiatory type) in standard glass test tubes in an electrically heated metal block, equipped with a platinum resistance thermometer. After raising the temperature at a rate of 5°C per minute, that temperature is noted at which a sample inflames, explodes or undergoes

rapid combustion (shown by a puff of smoke). Samples which give negative results below 400°C are reported as 'Not under 400°C' unless, upon examination, the material is seen to have decomposed, when it is reported as 'Decomposes slowly'.

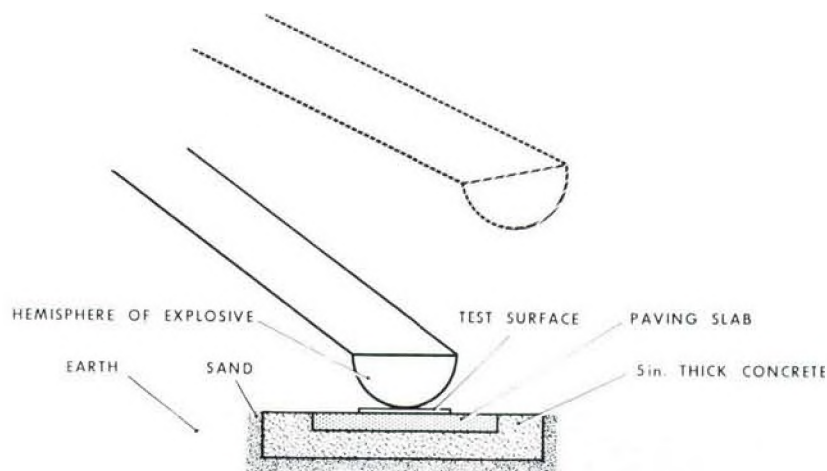

**Fig. 3 Charge oblique impact test**

**57.** The test is essentially one of thermal stability, and materials giving results in the range 140°C-170°C are found, in general, to have short Service lives and need to be subjected to regular surveillance testing and to be stored away from such sources of heat as steam pipes; those giving results below 140°C are usually not sufficiently stable for Service use. But the test is, of course, not a substitute for systematic testing for stability.

*Ease of ignition test*

**58.** The next question from the point of view of the Safety Certificate is what is the ease of ignition of an explosive material, and an assessment of this factor is made by determining: (1) whether a sample of the material will ignite from the short-duration burst of flame emitted from the end of a length of Bickford fuze, and (2) whether such a sample burns or explodes. The test is conducted in an approved safety cupboard equipped with a remotely controlled gas flame to ignite the Bickford fuze. A 3 g sample of the material is placed in a vertically clamped standard test tube and a 9 inch (229 mm) length of fuze is placed with one end centrally on the sample. It is recorded whether the material:

- (1) fails to ignite
- (2) ignites and burns quietly
- (3) ignites and burns vigorously
- (4) explodes.

**59.** If the material ignites under the light conditions of confinement of this test it must be assumed that any non-electric spark may ignite it (the electrostatic risk is a matter for separate assessment — see para. 62). Small changes in chemical composition or of physical form (for example, grain size) may result in a change from 'burns vigorously' to 'explodes' when testing pyrotechnic materials. If a material explodes in this test it must be assumed that it will do so on inflammation in any quantity, but a negative result (after several trials) must be supported by tests on a larger scale (see para. 61).

**60.** Many explosive materials which are not ignited in the 'Ease of Ignition (Bickford Fuze) Test' will burn when subjected to a naked flame of several seconds duration. Accordingly, the Safety Certificate calls for the application of the 'Train Test' to determine: (1) whether a loose or lightly confined material will ignite if a flame is applied for one minute, and (2) the hazard arising from an ignition. The test is conducted in an approved safety cupboard. A mild steel trough, 12 inches (305 mm) long and  $\frac{1}{2}$  inch (12.7 mm) diameter and with end plates, is completely filled (flush with the top edge) and ignited at one end, using a remotely controlled luminous gas flame. Results are reported as:

- (1) fails to ignite
- (2) ignites, but fails to support train for more than 'x' inches
- (3) ignites, but supports train fitfully

- (4) ignites and supports train steadily throughout
- (5) ignites and supports train vigorously throughout
- (6) explodes.

The physical form of the material under test can affect the results of this test also, though to a lesser degree than in the Bickford fuze test. Again, a material which burns vigorously, and could obviously lead to a rapidly spreading fire, may constitute an explosive risk if it is ignited in bulk — a matter which can only be assessed by tests on a large scale.

**61.** Large scale tests of the effects of heat on explosives are done by enclosing them in electrically heated steel vessels or by placing 10 lb (4.53 kg) of explosive in an appropriate container in a 'standard bonfire'. The assessment of such tests calls for experience.

#### *Electrostatic hazard testing*

**62.** In general, explosives may be divided into two classes when considering electrostatic hazard. It is possible under adverse conditions for an operative to accumulate 0.02 joule of electrostatic energy on his person, and for this reason explosives which can be initiated with energies smaller than 0.02 joule require special precautions in handling, as determined by their precise electrical ignition characteristics. The electrostatic testing of explosives is therefore divided into two parts: (1) a preliminary test to ascertain whether the material will be initiated at the 0.02 joule level, and (2) a much more searching procedure if it is so initiated.

**63.** For the preliminary test a sample holder is first prepared. It consists of a strip of polythene in which five  $\frac{1}{4}$  inch (6.6 mm) holes have been punched at centres not less than 2 inches (50.8 mm) apart. On the under side of the strip a copper foil is stuck so as to leave clean copper under each hole. The holes are filled loosely with the composition to be tested and each is covered with a  $\frac{1}{8}$  inch (15.88 mm) square of copper foil. The holder is then placed on a movable brass platform connected to one side of a non-inductive capacitor, the other side of which is connected to a brass terminal which can be brought into contact with each small square of copper in turn. The capacitor is charged to 9.5 kV and has three values capable of delivering 4.5, 0.45 and 0.045 joules; the discharge is through a thyratron valve acting as a switch. The test is conducted in a special cabinet and the results are reported as follows:

- (1) no ignitions at 4.5 joules
- (2) ignitions at 4.5 joules but not at 0.45 joules
- (3) ignitions at 0.45 joule but not at 0.045 joules
- (4) ignitions at 0.045 joule and requiring detailed investigation, possibly leading to a recommendation that stringent electrostatic hazard precautions be applied in the handling of the material under test.

**64.** Since the ignition energy of a material in sub-para. (4) above could well be less than 0.02 joule, the operative preparing samples for the next stage of testing must be earthed by the used of suitable footwear and flooring. On the other hand, for the actual spark testing, involving high-voltage equipment, the operative must be on an insulating floor. The explosive under test (0.015 g to 0.025 g) is measured and placed directly onto base electrodes, which are  $\frac{1}{4}$  inch (19.1 mm) steel bearing rollers. The upper electrode, which may be needle-shaped or more blunt, can be brought down gradually over the sample on the base electrode so that a spark passes when the gap is reduced to the breakdown value corresponding to the potential of the capacitor. If only a small percentage of ignitions have been obtained in the 0.045 joule test (9.5 kV; 1000 $\mu$ F) described in para. 63, the approaching electrode apparatus is used with a somewhat higher capacitance, say 2000 $\mu$ F, enabling a lower voltage to be used to provide the same energy whilst corona losses as the upper electrode is brought down are reduced. Fifty trials are carried out, reducing the energy of the spark by decreasing the potential of the capacitor until no ignitions are obtained in 50 consecutive trials; if this condition occurs at an energy value of about 0.02 joule, then 'First Degree Precautions' will be adequate in the handling of the material. If a large percentage of ignitions was obtained in the 0.045 joule test, the approaching electrode trial is continued using a 1000 $\mu$ F capacitor, dropping the voltage at each step to determine the minimum energy of ignition; if this is well below 0.02 joule, a second set of tests is done using a 500 $\mu$ F capacitor to pinpoint the minimum energy value more nearly. Also, another series of tests is done using a conducting, rubber-base electrode (a disc of the rubber placed on top of the steel roller); this introduces a resistance similar to that found when a spark is drawn from the finger of a charged person. The aim is to estimate the minimum ignition energy with various capacitances in order to be able to estimate more accurately the minimum capacitance for ignition.

#### *Miscellaneous sensitivity tests*

**65.** Many *ad hoc* tests have been devised to give some idea of the sensitiveness of explosives under practical conditions. One of these is the Rifle Bullet Test. It is usually performed on a quantity of explosive (up to 1 lb, 0.45 kg) contained in some form of closed steel vessel, but other containers — or even none — may be employed to match the conditions under which the explosive may be used in

Service. The impact of a high-velocity rifle bullet generates a shock wave which may initiate the explosive. Now a shock wave could be generated in an explosive charge by the adjacent detonation of another (standard) explosive charge, and this gives rise to the Gap Test, which is normally used as a test for functioning rather than for hazard, but will place explosives in the same order as the Rifle Bullet Test. One type of Gap Test is carried out, with small variations at RARDE, ERDE and AWRE. In the ERDE version a bare charge ( $\frac{1}{2}$  inch, 12.7 mm, square and 1 inch, 25.4 mm, long) of the explosive is placed upright on a steel 'witness' block (1 inch, 25.4 mm, cube), and is surmounted by an appropriate number of brass shims (each 1 inch, 25.4 mm, square and 0.002 inch, 0.05 mm, thick, held together by solder; the thickness can be varied by peeling off layers) which act as 'gap' between the test charge and a 2.5 g tetryl pellet ( $\frac{1}{2}$  inch, 12.7 mm, diameter and  $\frac{1}{2}$  inch, 12.7 mm, long) which has above it a No. 8 'Briska' detonator. The result is expressed in terms of the thickness of gap required to give a 50% probability of detonation, and some typical results are:

Explosive	Gap (inch)
Tetryl, pressed to 1.5 g/ml	0.292
Pentolite, 50/50 cast	0.150
Tetryl/TNT, 30/70, cast	0.133
RDX/Paraffin Wax, 83/17, cast	0.073
RDX/TNT, 60/40, cast	0.030
TNT, cast	Fails at zero

66. This Gap Test can be employed to evaluate only those explosives which have a detonation pressure high enough to produce a dent in the witness block, and those having a critical diameter not greater than  $\frac{1}{2}$  inch, 12.7 mm. Explosives of high blast pressure but low detonation pressure (for example Torpex) cannot be tested successfully. Soft or brittle explosives may not give reliable results. A Sand Test is used in the United States in which 0.40 g of explosive is pressed into a blasting cap shell under a pressure of 3000 lb/in<sup>2</sup> (20.7 MN/m<sup>2</sup>) and diminishing weights of lead azide are used to initiate it until that minimum weight is found which will cause complete detonation, as indicated by the crushing of the sand in which the cap is buried.

67. Large-scale impact tests on cased charges are numerous and range from systems in which a weight having studs on its under side is dropped onto the charge, or the charge is dropped onto studs or 'knife edges' upstanding from masses of concrete, to the American 'Spigot' and 'Susan' tests, versions of which are carried out in the United Kingdom (paras 68 and 69).

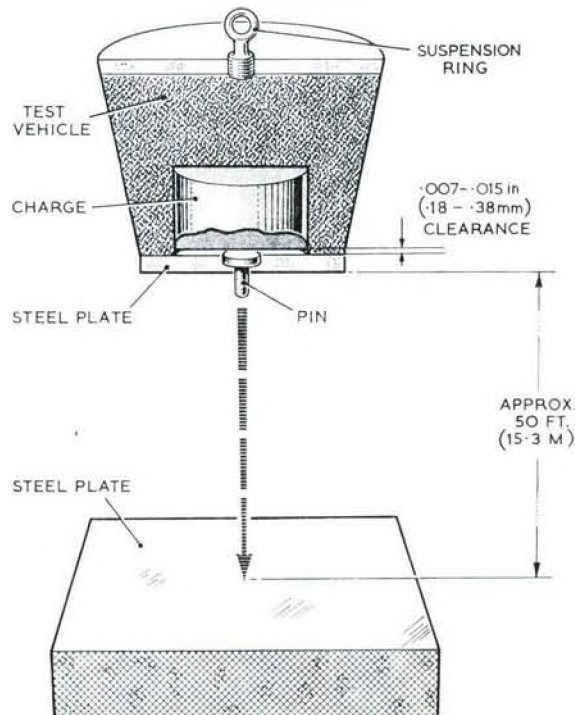

Fig. 4 Spigot-test apparatus

68. In the Spigot Test (American type), Fig. 4, a 6 inch, 152.4 mm, diameter by 4 inch, 101.6 mm, deep hole in the small end of a test 'vehicle' contains a charge of the explosive under test; the vehicle is a truncated right circular cone of an inert plastics-bonded material, of height 8½ in, 222.3 mm, and diameters 12½ in, 323.9 mm, and 8½ in, 222.3 mm. The small end of the vehicle is covered by a glued-on ½ in, 12.7 mm, thick steel plate which carries a central pin which is a sliding fit in a hole in the plate and which has a flat head which is separate from the explosive by an air gap of 0.007 in to 0.015 in, 0.18 mm to 0.38 mm, while the pin extends 1 inch outside the plate; this pin is the 'spigot' which gives its name to the test. The test vehicle is dropped, small end (and spigot) downwards, from a height of 50 feet, 15.2 m, onto a 4½ inch, 114.3 mm, thick steel plate and the phenomena are observed by a 3000 frames/sec cine-camera.

69. The Susan Test (Fig. 5) was developed to subject cased explosives to impacts at velocities greater than can be achieved in gravity-drop tests. A 'billet' of explosive of diameter 2 in, 50.8 mm, and length 4 in, 101.6 mm, (weight rather less than 1 lb, 0.45 kg) is enclosed in an aluminium cap which is inset into the front of a 3 in, 76.2 mm, solid steel projectile that is fired from a smooth-bore gun at a 2½ inch, 63.5 mm, thick armour plate 12 feet, 3.7 m, from the muzzle. The velocities employed are usually in the range 100-1200 ft/sec, 30.5 to 366 m/s, but velocities up to 3500 ft/sec, 1.07 km/sec, can be used; they are measured as the projectile travels between muzzle and target. The explosive phenomena are recorded cinemographically, and the moment of impact and the blast pressures at various points are measured. The principal way of expressing the results of a set of Susan Tests is by a 'Sensitivity Curve', which is a plot of corrected over-pressures (derived from the blast-pressure data) against projectile velocity.

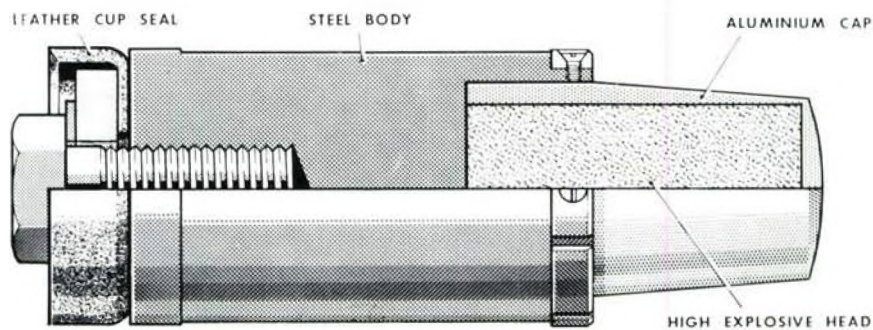

Fig. 5 Susan-test apparatus

**ANNEXE A**  
**Properties of Explosives**  
**and of some Compositions**

Explosive	Composition	Melting point (°C)	Density (g/ml)	(a)	(b)	Sensitiveness to friction			Velocity of Detonation related to charge density	
				Power (lead block)	Figure of Insensi- tiveness (Rotter)	Stone	Wood mallet on:— Softwood	Hardwood	V of D m/sec	Charge density g/ml
1	2	3	4	5	6	7a	7b	7c	8a	8b
TNT	—	80.7	1.65	95	>150(c)	0	0	0	6950	1.57
Tetryl (CE)	—	129.5	1.73	120	110	50	0	0	7160	1.50
PETN	—	141	1.765	165	50	100	0	0	8300	1.56
RDX	—	204	1.805	170(d)	80	0	0	0	8400	1.56
$\beta$ -HMX	—	278	1.905	160(d)	60	0	0	0	8410 9120	1.79 1.84
Picric Acid	—	122.5	1.81	100	120	0	0	0	6800	1.50
NG	—	13	1.595	175	(13)	100	0	0	7700	1.60
Nitroguanidine (Picrite)	—	238	1.76	100	>120	0	0	0	7650	1.55
Amatol 40/60	AN/TNT 40/60	—	1.70	120	(115)	0	0	0	5850	1.50
Amatol 80/20	AN/TNT 80/20	—	1.71	135	(120)	0	0	0	5080	1.50
Minol 1	AN/TNT/Al 48/42/10	—	1.75	135	(147)	0	0	0	6300	?
Minol 2	AN/TNT/Al 40/40/20	—	1.82	155	130	0	0	0	5900	1.65
RDX/TNT 60/40	RDX/TNT 60/40 +1% Wax	—	1.75	125	140	0	0	0	7700 7900	1.60 1.72
Torpex 1	RDX/TNT/Al 45/37/18	—	1.78	(154)	(100)	0	0	0	7440	1.80

RESTRICTED

RESTRICTED

## Annexe A (cont'd)

1	2	3	4	5	6	7a	7b	7c	8a	8b
Torpex 2 (Cast)	RDX/TNT/Al 42/40/18	—	1.85	155	110	0	0	0	7360 7500	1.79 1.81
Torpex 2B	Torpex 2 + 5.5% desensitizer	—	1.77	—	170	0	0	0	—	—
Torpex 4D	RDX/TNT/Al 20/5.5/25 + 5% Wax No 6 + up to 2.5% carbon black	—	1.83	—	200	0	0	0	—	—
EDC 1	HMX/RDX/TNT/Wax 70/4/25/1	—	1.826	—	90	0	0	0	8330	1.76
RDX/Wax	RDX/Wax No 8 91/9	—	1.68	128	90(e)	—	—	—	7960	1.55
RDX/Wax aluminized	RDX/Al/Wax 71/20/9	—	1.784	150	180	—	—	—	7750	1.72
Pentolite	PETN/TNT 50/50	—	1.71	115	130	0	0	0	7465	1.66

## NOTES:

Al = Aluminium

AN = Ammonium Nitrate

NG = Nitroglycerine

PW = Paraffin Wax (used with 0.1% Lecithin)

- (a) There is a good deal of variation in recorded Lead Block (Trauzl Test) figures (some of it no doubt due to variance in the physical properties of the cast lead blocks) and the figures given are 'rounded' to the nearest five units. They are usually higher than the values obtained by the Ballistic Mortar Test, which are often nearer to values of the power calculated from the heat of explosion and the volume of gas generated in explosion. Figures given in brackets in this column are Ballistic Mortar values.
- (b) The figures in this column are the result of testing 200 caps against an equal number of caps of standard RDX (F of 1 = 80). If the figures are in brackets they are the results obtained by the original Rotter method against a picric acid standard.
- (c) The value depends upon the type, for example creamed TNT is >200.
- (d) There is no obvious reason for the difference between these figures, which appears from at least two sources. The Ballistic Mortar gives a figure of about 150 for both RDX and HMX.
- (e) The use of Wax No 6 (Chapter 13) improves this figure to 130.

## CAUTION:

It should be noted that the figures in Col 6 afford no justification for handling any secondary explosive with any less care than would be used when working with PETN. All that can be said is that if the F of 1 of an explosive is less than 50 the material should be treated as if it were a primary explosive (Typical Fs of 1: Cap Composition 6:6:4 — 6; Lead Azotetrazole — 10; Lead Azide — 13; Lead Styphnate — 20; Barium Styphnate — 40), and such explosives commonly have figures in Cols 7a, b and c. If the figure is between 50 and 100, the material is generally unsuitable for use in munition stores unless first desensitized (for example, PETN/Wax for exploder pellets). If the figure is above 100, then the higher it is the better suited the filled charge is to withstand rough usage and shock on impact.

ANNEX B

**Scheme for the Safety Control of Proposals for New Work**

1. This set of forms is designed to ensure that adequate attention to safety is given to all new work on propellants and ingredients. The forms should be used:
  - (1) whenever a new piece of equipment is designed for either laboratory or plant use
  - (2) whenever an existing piece of equipment is modified in any way
  - (3) whenever a new piece of purchased equipment is brought into use
  - (4) whenever a new method or technique is to be assessed or introduced
  - (5) whenever a new propellant ingredient is to be handled in any way.
2. Proposals for new work must be submitted to the Superintendent by the Section Leader on Form P2/1. The Superintendent will then decide if work can go ahead, or if further action on Form P2/2, *etc* is required.
3. Forms P2/2, P2/3 and P2/4 are intended for plant use. When completed, Form P2/2 will give detailed proposals for the project, including the design, location, proposed method of operation, assessment of hazards involved and precautions to be taken. It will include comments by Establishment Safety Officer, Chief Engineer and Section Leader, and approval by the Superintendent. Form P2/3 is to check the safety of agreed equipment. Form P2/4 is to cover an agreed programme for initial runs and development modifications until Operating Instructions are issued.
4. Form P2/5 is intended for laboratory experimental work involving new equipment or techniques and/or the use of new materials. It should be noted that normal safety practices and precautions regarding the operation of common laboratory apparatus and the use of common chemicals will, of course, apply and will not be covered by this form.
5. Forms P2/6 and P2/7 are intended for the assessment of new propellant ingredients.

**Proposals for New Work**

1 **Object of Work**

2 **Brief Details of Design of any Equipment Involved**

3 **Materials to be used**

4 **Assessment of Hazards Involved**

Prepared by \_\_\_\_\_

Submitted by \_\_\_\_\_  
(Section Leader)

Date \_\_\_\_\_

**Superintendent's Decision**

(a) This work may proceed without further action on forms

(b) This work is allocated Experimental Project No. \_\_\_\_\_ and further action should be taken on Form P2/

Date \_\_\_\_\_

**Proposals for Design of New Plant — Experimental Project No.**

This form is to be completed by the officer in charge of processing and/or the Section Leader who will forward the final proposal to the Superintendent. The attached Notes for Guidance must be read in conjunction with this form.

**1 Object**

**2 Brief Details of Design** (drawings to be attached)

**3 Proposed Method of Operation** (with reference to detailed items in drawings attached)

**4 Explosive Use Intended**

- 4.1 Nature and amount
- 4.2 Sensitiveness
  - (a) Impact (Rotter machine, RDX = 80)
  - (b) Friction
  - (c) Behaviour on Ignition
  - (d) Spark
- 4.3 Stability
- 4.4 Compatibility with Materials of Construction

**5 Assessment of Risks** (some experimental work may be necessary before the assessment can be made)

- 5.1 Where could risk of fire or explosion occur from impact or friction?
- 5.2 Is there excessive confinement at any stage of the process?
- 5.3 Do electrostatic hazards exist? Is assessment required?
- 5.4 Are there toxicity hazards?

**6 Design Considerations Arising from Assessment of Risks**

- 6.1 Special constructional materials required (including gaskets and packing)
- 6.2 Special mechanical features
- 6.3 Safety requirements (aspects such as remote control, electrical equipment, temperature and pressure control, electrostatic hazards, drenching equipment, solvent vapours, control valves, venting, and guards)

7 Installation and Use

- 7.1 Location
- 7.2 Protection of personnel
- 7.3 Facilities for remote operation and viewing
- 7.4 Personal safety equipment
- 7.5 Emergency stop requirements
- 7.6 Special venting to building (see Notes)
- 7.7 Any general drenching required
- 7.8 Limitation on adjacent work
- 7.9 Method of collection of material
- 7.10 Method of cleaning equipment
- 7.11 Special precautions

Prepared by \_\_\_\_\_

Date \_\_\_\_\_

Submitted by \_\_\_\_\_

Date \_\_\_\_\_

Experimental Project No. \_\_\_\_\_

Form P2/2 (page 3)

Comments by Safety Officer

Comments by Chief Engineer

Comments by Section Leader

Approval by Superintendent  
Final design approved comprises

Superintendent \_\_\_\_\_

Date \_\_\_\_\_

**Proposals for Design of New Plant —  
Notes for Guidance for Completing Form P2/2**

1 *Object*

An indication of the possibility of eventual 'scale-up' should be included since this may influence the degree of protection required. Thus, an experiment may be carried out with 1 lb of propellant and, if successful, be scaled-up to 10 lb. In such an event it may be just as easy to provide protection for the 10 lb scale from the beginning.

2 *Brief Details of Design*

A flow sheet of the process should be given, together with a brief description of the plant and pipework involved, with positions of operating controls, etc.

3 *Proposed Method of Operation*

A step-by-step outline of the operating method is required (using a separate sheet if necessary). Method of collecting and removing explosive material should be included.

4 *Explosives Use*

The nature and amount of explosive present at various stages of the process should be given.

4.1 *Sensitiveness Data*

This must be obtained for the materials in the various relevant stages of processing to indicate points of danger (see Forms P2/6 and P2/7). If a solvent or diluent is involved, attention should be paid to the quantity used since this may have a profound effect on sensitiveness.

The usual sensitiveness tests are:—

4.1.1 *Impact Sensitiveness* Results are given in terms of the median height at which 20 mg of the material will explode when subjected to a falling 5 kg weight in the Rotter machine, relative to a standard material (RDX = 80).

Typical figures are:—	RDX	80
	Plastic propellant	50 to 200
	SC Cordite	19
	Guncotton (dry)	23
	N.G.	13
	Ammonium perchlorate	85

4.1.2 *Friction* The results of friction tests between various surfaces indicate the degree of friction hazard and assist in the choice of materials for plant and tools.

Tests are normally carried out with mild steel hammers on anvils of mild steel, naval brass, and aluminium bronze, and with box wood hammers on anvils of york stone, hard wood, and soft wood. Other surfaces may be included on special request.

Results are reported as number of ignitions out of 10 separate tests. Figures greater than 0/10 on soft wood indicate 'very sensitive' materials and work on propellants in this class requires special consideration and, possibly, modified procedures. Figures greater than 0/10 on york stone indicate 'sensitive' materials and propellants are often in this class.

4.1.3 *Behaviour on Ignition* (including temperature of ignition and ease of ignition).

4.1.4 *Spark Sensitiveness* If ignitions are obtained with spark energies less than 0.045 joule, strict antistatic precautions are required. If no ignitions are obtained with spark energies up to 4.5 joule, normal earthing precautions are adequate.

4.2 *Chemical Stability*

Consideration must be given to the compatibility of materials under process with materials of construction and with the possibility of self-heating, or of heating induced by moisture, as with metal powders.

5 *Assessment of Risks*

Factors which must be considered include:

5.1 *Potential Causes of Ignition*

- Presence of solvent vapour, particularly in relation to explosive limits
- Electric spark, through static or faulty electrical apparatus
- Overheating
- Friction between moving parts

Foreign bodies giving rise to friction  
 Falling or loose objects striking metal surfaces  
 Contamination with oil or other carbonaceous material

#### 5.2 *Risk of Detonation*

Depends on energy, degree of confinement, *etc.* of material involved

#### 5.3 *Electrostatic Hazards*

Protection is required according to the degree of hazard (see 4 above). In addition, careful consideration regarding means of earthing must be given to operations likely to generate static electricity, *eg.* pouring or mixing of dry powders, moving belts, *etc.*

#### 5.4 *Toxic Hazards*

Materials can cause toxic effects by ingestion, inhalation, or skin absorption. The advice of the Safety Officer should always be obtained. Relevant information on a wide range of materials is given in Appendix 7, ARE Safety Precautions Handbook (1954).

### 6 *Design Considerations*

#### 6.1 *Materials for Tools and Plant*

Whilst orthodox materials are generally satisfactory, this may not always be the case and the results of friction tests will provide guidance. Consideration should be given to the use of plastics such as teflon, polythene and polystyrene which generally have low friction sensitiveness characteristics.

#### 6.2 *Mechanical Aspects*

The main requirement is to avoid or reduce friction and impact; clearances on blade shafts and extrusion rams must be specified, and bearings must be such that required clearances are retained in use. Where necessary a drenching system must be devised at the inception of the design. Bearings should be remote from explosives and/or protected by sealing glands. Loose parts should be avoided but where essential they should be wired in place. Adventitious foreign bodies should be avoided by filtering or sieving. Easy inspection and maintenance should be provided for in the design and smooth operation of controls and plant should be a major consideration. Blind screw holes and screw threads which might become contaminated with explosive must be avoided.

#### 6.3 *Safety Requirements*

6.3.1 *Remote control* The need for remote control should be carefully considered. Vibro feeding devices, cut-off valves, limit switches, pneumatically or hydraulically operated handling devices, interlocks, and viewing devices such as telescopes, periscopes, mirror systems, and TV may be required. Close viewing of an experimental process of doubtful reliability must be avoided by appropriate devices in the initial design.

6.3.2 *Standard of electrical equipment* Four types of electrical equipment (motors, motor controls, and lighting) are available.

1. Flameproof
  - Group 1. Methane
  - Group 2. Solvent vapours such as acetone, diethylether, benzene, cyclohexanone, methyl or ethyl alcohol, ethylene, propane, butane, *etc.*
  - Group 3. Coal gas, coke oven gas
  - Group 4. (Not in production.) Ethyl nitrate, acetylene, hydrogen
2. Total enclosed, including totally enclosed fan cooled
3. Dust tight
4. Intrinsically safe (low voltage)

In instances where none of the present types can be used (*eg.* nitroglycerine, ethyl nitrate, hydrogen) electrical equipment must be placed external to the process room.

6.3.3 *Solvent vapours* Facilities for purging and detection may be necessary. The level should be kept below the explosive limit even if a source of ignition seems unlikely.

6.3.4 *Electrostatic* Solvent vapours are readily ignited and Grade I anti-static treatment may be required. Earthing and complete continuity will normally be required for all plant equipment.

6.3.5 *Location of internal drenching devices* There is a choice between quick acting (0.15 second) automatic, and manual devices. Special consideration of the nature of the extinguishing medium may be required.

6.3.6 *Guarding of moving parts* There are statutory requirements which must be followed where possible; any departure found essential should be noted.

6.3.7 *Blow-out panels* Where venting is considered desirable because of the quantity and violence of a possible explosion, construction should be as light as possible and consideration should be given to the incorporation of special venting areas.

6.3.8 *Valves* The choice of valves is dependent on the degree of control required. Explosives must never be subjected to impact between metal surfaces so that where a quick acting valve in contact with explosive is required, the diaphragm type should be used. The choice of material for the diaphragm will depend upon considerations of sensitiveness and chemical compatibility.

6.3.9 *Requirements for temperature and pressure control* Thermostatic devices should be in duplicate, or an overriding cut-out should be incorporated. Hot water heating is preferable to electrical heating.

## 7 *Installation and Preparation for Use*

### 7.2 *Protection of Personnel*

Where remote control is specified, personnel must be completely protected during operation of the plant. The degree of physical protection used must be appropriate to the explosive hazard of the quantity of material being processed. Any viewing windows must be as small as possible and of strength advised by the Safety Officer.

In instances where permanent building alterations are not justified for remote control purposes, consideration should be given to:

- (1) Delineation of safe areas from which the process can be viewed by means of a mirror system
- (2) Use of mantlets to screen off doorways and plant

### 7.4 *Personal Safety Equipment*

Toxic effects and risk of injury can be guarded against by the use of protective equipment: —

- (a) Air pressure units or masks
- (b) Dust masks
- (c) Gas masks
- (d) Barrier creams
- (e) Protective clothing, including gloves, safety spectacles, face visors, ear plugs, ear muffs
- (f) Localised exhaust ventilation

### 7.6 *Venting to Building*

Venting normally required is about 10 ft<sup>2</sup> of venting area for each 100 ft<sup>3</sup> of building space.

**Proposals for New Laboratory Work — Experimental Project No.**

This form is to be completed by the officer in charge of the new work and/or the Section Leader who will forward the final proposal to the Superintendent.

- 1 **Object**
- 2 **Brief Details of Design** (drawings to be attached)
- 3 **Proposed Method of Operation**
- 4 **Explosive Use Intended**
  - 4.1 Nature and Amount
  - 4.2 Sensitiveness
    - (a) Impact (Rotter machine, RDX = 80)
    - (b) Friction
    - (c) Behaviour on ignition
    - (d) Spark
  - 4.3 Stability
  - 4.4 Compatibility with Materials of Construction
- 5 **Assessment of Risks** (some experimental work may be necessary before the assessment can be made; Library Services will, on request, make a search for relevant hazard information concerning particular chemicals).
  - 5.1 Where could risk of fire or explosion occur from impact or friction?
  - 5.2 Is there excessive confinement at any stage of the experiment?
  - 5.3 Do electrostatic hazards exist? Is assessment required?
  - 5.4 Are there toxicity hazards?
  - 5.5 Is the equipment likely to be subjected to pressure?  
Particularly where glass apparatus is employed, is there adequate protection against flying particles?
  - 5.6 Are all personnel involved aware of the potential hazards?
  - 5.7 What protective clothing is recommended?
  - 5.8 Is the work to be carried out in an approved safety cupboard?

5.9 What limits, if any, are to be placed on other work being carried out in the same laboratory at the same time? (This will depend on compatibility risks, risk of vapour ignition by use of flames, etc.)

5.10 What limit, if any, is to be placed on the number of persons allowed in the laboratory while the experiment is in progress?

Prepared by \_\_\_\_\_

Date \_\_\_\_\_

Submitted by \_\_\_\_\_

Date \_\_\_\_\_

**Approval by Superintendent**

Superintendent \_\_\_\_\_

Date \_\_\_\_\_

**Proposals for Assessing a New Propellant Ingredient**

1 **Name of Ingredient**

2 **Compositions in which Ingredient will be Used**

3 **Stability**

4 **Compatibility**

- (a) With other ingredients
- (b) With materials of construction

5 **Sensitiveness**

- Friction
- Impact
- Spark

6 **Brief Details of Equipment for Processing and Handling**

Prepared by \_\_\_\_\_

Submitted by \_\_\_\_\_  
(Section Leader)

Date \_\_\_\_\_

**Superintendent's Decision**

- (a) This work may proceed without further action on forms.
- (b) Please take action outlined on Form \_\_\_\_\_ using a \_\_\_\_\_ g batch and taking all possible precautions during manufacture and handling.

Superintendent \_\_\_\_\_

Date \_\_\_\_\_

**Sensitiveness of Propellant Containing a New Ingredient**

1 **Name of Ingredient**

2 **Size of Batch**

3 **Composition**

4 **Sensitiveness**

(a) Premix

Friction

Impact

Spark

(b) After incorporation

Friction

Impact

Spark

(c) After deaeration or cure

Friction

Impact

Spark

Prepared by \_\_\_\_\_

Submitted by \_\_\_\_\_

(Section Leader)

Date \_\_\_\_\_

**Superintendent's Decision**

(a) No further work may be carried out on compositions of this type

(b) A full assessment of this ingredient in compositions of this type may be made using  $\frac{\text{normal}}{\text{special}}$  precautions during manufacture and handling

Date \_\_\_\_\_

ANNEXE C

Classification of Explosives Hazards

1. Considerable discussion is taking place within various national and international policy-making committees towards achieving an international system of common explosives-hazard classifications. The United States authorities and the United Kingdom Services are aware of each other's systems, and there are now Nato and United Nations Organisation systems towards which all nations are working (1971).
2. Various hazard classifications may be used from time to time and Table C1 below has been drawn up to enable a comparison to be made between the four classification systems.
3. Although the United Kingdom will eventually recognize and adopt the United Nations Organization system, it will be some years before this happens.

**Table C1**  
**Comparative Table of explosive-hazard classification systems**

NATO Hazard Classes	UK		USA		UNO Storage and Transport
	Quantity	Distance Category	Quantity	Distance Class	Hazard Classes
0		NIL		INERT	1.4
1		X		1	1.2
2		Y		2, 2A and 12	1.3
3		X		3 or 4 (1)	1.2.3
4		X		4 or 5 (1)	1.2.4
5		ZZ		9	1.1
6		Z		6, 7, 8 and 10	1.1
7*		Special U		11	—

\* Toxic chemical stores

## CHAPTER 15

## Quality control, environmental effects and compatibility

## CONTENTS

	<i>Para</i>
<b>Specification and inspection responsibilities</b>	1
<b>Function of DQA (Mats)</b>	4
<b>Stability and compatibility tests</b>	7
<i>Abel's heat test</i>	8
<i>Silvered-vessel test</i>	14
<i>Vacuum-stability test</i>	16
<i>Will test</i>	21
<i>Bergmann and Junk test</i>	22
<i>Woolwich test (for single-base propellants)</i>	23
<i>Methyl violet test</i>	24
<i>Colour test for carbanite cordites</i>	25
<i>Nuto test for propellants</i>	28
<i>Dewar-vessel test</i>	29
<b>Environmental tests</b>	32
<b>Compatibility</b>	39
<i>Compatibility of metals and explosives</i>	41
<i>Compatibilities of various explosives</i>	42

## Illustrations

<i>Fig</i>		<i>Page</i>
1	Apparatus for Abel's heat test	4
2	Silvered-vessel apparatus	5
3	Vacuum-stability test	6
4	Combustion tube for Will test	7
5	Test tube and absorption bulb for Bergmann and Junk test	7

## CHAPTER 15

### Quality control, environmental effects and compatibility

#### Specification and inspection responsibilities

1. In previous Chapters there have been frequent references to the care which must be taken at all stages in the development and subsequent manufacture of an explosive or explosive composition to ensure that it is both inherently stable and stable in contact with those explosive or non-explosive materials with which it may be associated in Service use. It must also be ensured that it will continue stable during a long period in the Services both in this country, and abroad where climatic conditions may be very severe and may vary widely. Safety, combined with readiness to function efficiently, is a requirement for munition stores in peace as in war, and these qualities must persist for as long as the store is required to remain in Service. The achievement of stability, compatibility and long Service life are the objects of the development phase of an explosive and an important item is the drafting of a specification to control those chemical and physical properties which the explosive must possess at the time of manufacture to ensure the maintenance of those qualities in Service. Since the quality of an explosive or explosive composition will depend on that of the materials from which it is made, these also must generally be controlled by specifications. The formalization of all such specifications and also of those to govern the quality of materials with which the explosives will be in contact in packages or in munition stores has long been the responsibility of the Director of Quality Assurance (Materials), formerly Director of Chemical Inspection who maintains staff to carry out inspection to the requirements of the specifications both in Royal Ordnance Factories and at other establishments throughout the country. He is also responsible for the continued surveillance of explosives in bulk storage. Although QAD (Mats) is for administrative purposes in the Army Department of the Ministry of Defence, it is in fact a Joint Services Quality Assurance Directorate and performs its specialized function over the whole of the Defence procurement field.

2. When the explosive becomes a 'filling' or a 'charge' it is inspected to appropriate design specifications by the staffs of the Director of Quality Assurance (Weapons) or of the Director of Weapon Quality (Naval) as appropriate. DQA(W) is also normally responsible for the specifications for propellants, delegating their chemical and closed-vessel testing to DQA (Mats) and the ballistic proof of propellants for ordnance and mortars to the Chief Superintendent of Ranges (CRS).

3. When the filled store is in Service it comes under the surveillance of the staffs of the Chief Inspector of Land Service Ammunition, the Director General of Weapons (Naval) or the Director of Aeronautical Inspection Services, as appropriate.

#### Functions of DQA (Mats)

4. This Textbook is primarily concerned with explosives and explosive compositions as such, and with the materials with which they will be in contact or in proximity to in filled stores rather than those filled stores themselves. It is convenient to consider here the functions of DQA (Mats) with respect to these aspects.

5. It has been said that the Directorate is responsible for the formalization of specifications. These long existed in two series, CS and TS. The former dealt with well-established materials while the latter was one of specifications the nature of which had an element of the temporary, usually because the material to which it related either was or might be in a state of development. TS specifications continue to be issued as required, but CS specifications have been replaced by British Standards or by Defence Standards, the former drawn up under the auspices of the British Standards Institution (often in association with the International Standards Organisation) to cover a wide range of products of commercial and industrial importance, and the latter to cover materials primarily of military interest. When it is necessary that a material covered by a Defence Standard shall conform to particular compatibility requirements in order to be acceptable for use in explosive stores, its title is followed by the phrase 'Type X'. As far as possible all Defence Standards are unclassified documents, in order that the commercial world may understand Service requirements fully.

6. While the Directorate has laboratories in the Royal Ordnance Factories concerned with explosives, it also has a number of laboratories elsewhere to deal with the control of materials procured from industry; because of the elaborate nature of much modern analytical and testing equipment some of these laboratories assume specialist functions. The very large number of firms from whom materials are procured has led to the introduction of the 'Approved Firms' Inspection procedure, under which the quality control departments and laboratories of the firms exercise control over the compliance of their products with specification under the overall supervision of visiting staff of the Directorate, who check samples.

### Stability and compatibility tests

7. Although it is not appropriate to this book to discuss the general methods of chemical and physical testing which are applied to explosives, there are some important tests for stability and compatibility which may come to the notice of the reader and to which attention should be drawn. Essentially, these depend on the principle that, in general, chemical reactions (whether of spontaneous degradation or of interaction) are accelerated by heat. But, to avoid misleading results, in applying such tests discrimination is required in the choice of temperature; while high temperatures may shorten the time required for a test they may also induce reactions which would not otherwise occur.

#### Abel's heat test

8. Abel's heat test is the oldest test for determining the stability of nitrocellulose. It was devised by Abel who had noticed that an early sign of the degradation of nitrocellulose was the appearance in the air above it of the brown fumes of nitrogen tetroxide,  $N_2O_4$ . The test, which because of its simplicity is still much used for propellants and explosives which may by any means give rise to  $N_2O_4$  as a product of degradation, depends on the reaction of  $N_2O_4$  with potassium iodide to liberate iodine; the potassium iodide is present in a starch-iodide test paper which gives a characteristic blue colouration when iodine is liberated in sufficient concentration.

9. The equipment employed in the Heat Test is fully standardized (Fig. 1), as is the preparation of the test papers.

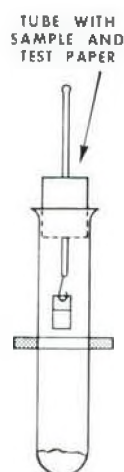

Fig. 1 Apparatus for Abel's Heat Test

10. A sample of the explosive to be tested is weighed into a test tube; in the instance of propellants it is taken from a quantity of ground and sieved material. A test paper is suspended on a platinum hook above the sample; the upper half of the paper is wetted with a (non-drying) solution of glycerol in water. The lower end of the tube is immersed in a water bath which is maintained at a constant temperature (usually between  $60^{\circ}C$  and  $82^{\circ}C$ ). During the test the upper part of the tube is shielded from light by a loose opaque cover to prevent actinic effect on the test paper. The first traces of  $N_2O_4$  are indicated by a brownish-tinted line at the junction of the wet and dry parts of the test paper; this line deepens in colour and the test is complete when a standard colour is attained, corresponding to only  $0.000135$  mg  $N_2O_4$ , whence it will be seen that the test is very delicate. (In fact, it must be conducted in a 'clean' room, the atmosphere of which is free from possible contaminants such as ozone, halogens, *etc.*, which might give rise to spurious results.) The time required to attain the test colour is noted as a measure of the stability of the explosive relative to that of other samples of the same type.

11. The test may be used to indicate possible effects of other substances on an explosive; but some of these (mercuric chloride,  $HgCl_2$ , is a notable example) may give false results by retarding the reaction between  $N_2O_4$  and the test paper, while others may give rise to products which will shorten the test.

12. The test is not considered suitable for propellants in whose manufacture alcohol or ethyl acetate has been used in the gelatinization stage, since residual traces of these solvents will prolong the test. The presence of a stabilizer in a propellant will generally prolong the test as compared to the duration of the test for a basic composition free from stabilizer: the acceptance test for new cordite MD was a minimum of 30 minutes at  $82^{\circ}C$  while that for the modern carbamate-stabilized cordites (which are more stable than cordite MD) is 10 minutes.

13. Sensitive as the Heat Test is, conformity with the specified requirement by a propellant sample taken from storage is usual. However, failure to meet the requirement is not a sufficient ground for condemnation of the whole of the propellant but an indication of abnormality, the causes of which should be sought by alternative tests other than the Abel Heat Test, for example, the Woolwich test, para. 23.

#### *Silvered-vessel test*

14. The silvered-vessel test (Fig. 2) is not nowadays used for routine purposes, but may be valuable for special studies of stability. It was devised by R. Robertson, at Waltham Abbey, for the investigation of cordite Mk I which had given spontaneous inflammations in India. It gave an estimate of the remaining life of a cordite by finding the time taken to develop a dangerous rate of decomposition when the material was maintained at a temperature of 176°F (80°C) from which the estimated life at a more moderate temperature could be computed by using a temperature coefficient of the rate of the degradation reaction of 1.8 per 10°F (5.55°C) which had been experimentally determined. Thus, if the cordite survived 300 hours at 176°F (80°C) in the silvered-vessel test its probable life at 76°F (24°C) would be  $300 (1.8)^{10}$  hours — approximately 12 years. [Note: It may be remarked that the above temperature coefficient is still much used in rough assessments of the life of modern double base propellants. The assessments are probably safe since such propellants contain stabilizers much more effective than the mineral jelly used in cordite Mk I. But it should be remembered that a relevant coefficient should be measured in examples of importance.]



**Fig. 2 Silvered vessel apparatus**

15. The test vessel is a small vacuum-jacketed, silvered flask into which about 70 g of ground and sieved cordite is packed; a thermometer is inserted so that its bulb is positioned in the middle of the mass. The flask, which has a side-tube joined to its neck, together with a similar flask containing a control sample, is placed in a bath maintained at 80°C. A preliminary warning that active decomposition is beginning is given by the appearance in the side-tube of brown fumes of  $N_2O_4$ , but the end-point of the test is reached when the thermometer records 82°C. Since rapid decomposition may follow the rise in temperature it is desirable that the time of the test be not less than 400 hours so that the chance of decomposition occurring in an interval between inspections is reduced. Because of the amount of material involved, the test should be carried out in an isolated building fitted with adequately-protected compartments to separate the test baths.

#### *Vacuum-stability test*

16. The vacuum stability test was designed by Dr R C Farmer in the Research Department, Woolwich, primarily as a stability test for tetryl, but it is still much used for other explosives, sometimes as a specified routine test as well as in the investigation of the compatibility of explosives with one another or with materials with which they may come in contact.

17. Farmer had noticed that most explosives of the nitro-compound type appeared to undergo only little decomposition in the solid state, even at temperatures approaching the melting point, but that gradual decomposition with evolution of gas occurred at temperatures between the melting and ignition points; such decomposition was accelerated by the presence of impurities (which might include solvents used in recrystallization) while the presence of moisture could lead to erratic results. Tetryl, however, was remarkable in that appreciable decomposition could occur, even in a well-purified sample, at a temperature almost  $10^{\circ}\text{C}$  below the melting point — above which its rate of decomposition increased some fifty times. He observed that admixture of picric acid to tetryl greatly reduced the stability of tetryl, and as picric acid is a product of the decomposition of tetryl this appeared to account for instability of the tetryl on heating. Farmer found that the decomposition of tetryl had a temperature coefficient of 1.9 per  $5^{\circ}\text{C}$ , and remarked that this is much the same as for other explosives which undergo gradual decomposition (see the Note in para. 14). He also remarked that the application of this coefficient to a sample of tetryl which had evolved little gas at  $120^{\circ}\text{C}$  would imply a life of 1700 years at  $20^{\circ}\text{C}$ , a figure which should be treated with reserve owing to the complex nature of the decomposition — advice which is often relevant when temperature coefficients are applied over a wide range of temperatures.

18. The test is a quantitative one in that the volume of gases evolved on heating is measured. A weighed quantity (usually 5 g) of explosive is placed in a test tube of 15 ml capacity (Fig. 3), which is connected by a mercury-sealed ground joint to a vertical mercury manometer made of calibrated glass capillary tubing, having at its lower end a mercury reservoir. The system is exhausted by a vacuum pump connected through the mercury reservoir and the tube is placed in a bath at the test temperature ( $120^{\circ}\text{C}$  for tetryl) for 1 hour to remove traces of volatile matter from the explosive. At the end of this period the system is re-evacuated and the tube is returned to the bath. After a further 1 hour the height of the mercury column in the manometer is read and further readings are taken during the next 40 hours, or until a given volume of gas has been evolved. At each reading the room temperature in the vicinity of the

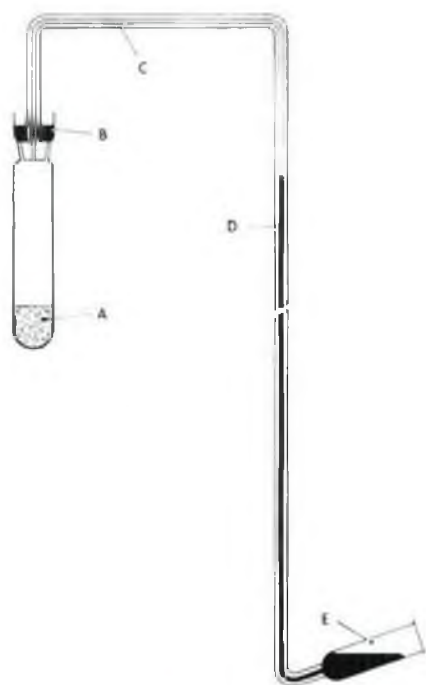

The tube containing the explosive is shown at A. Above the neck of the tube can be seen the small trough B and the capillary tube C. Mercury can be introduced into this trough where it serves as a seal. The capillary tube C leads to the manometer D at the lower end of which is the reservoir E for the mercury.

Fig. 3 Vacuum stability test

manometer and the barometric pressure are also recorded so that the volumes can be reduced to STP. The current specification for tetryl calls for evolved gas not exceeding 7 ml in 40 hours at  $120^{\circ}\text{C}$  (that is,  $9^{\circ}\text{C}$  below its melting point).

19. Explosives other than tetryl are tested at other (appropriate) temperatures; thus mercury fulminate is tested at  $80^{\circ}\text{C}$  because it is liable to explode at  $100^{\circ}\text{C}$ , and RDX at  $150^{\circ}\text{C}$  because decomposition is too slow at  $120^{\circ}\text{C}$ . The admixture with an explosive of anything which will lower its melting point to a temperature below that at which it is normally tested will result in more rapid decomposition if the test on the mixture is performed at the normal test temperature (apart from any other effect which the additive may have on the stability of the explosive) so that a new, lower, test temperature must be chosen at which the explosive remains solid.

20. It will be realised that the conditions of this test are such that only a low concentration of the gaseous, or other volatile, products of decomposition remains in the vicinity of the explosive under test, so that any effect they might have in accelerating (that is, catalyzing) its decomposition is thus reduced.

*Will test*

21. The stability of nitrocellulose was, from its earliest days, recognized as a matter calling for assessment. The earliest quantitative test (Fig. 4) was due to Will, but it is little used now except for special investigations. It consisted in heating a weighed sample of dry nitrocellulose at 135°C in a slow stream of pure carbon dioxide, which carried the gaseous products of decomposition over a heated mixture of copper and copper oxide. Here nitrogen oxides were reduced to nitrogen while carbon monoxide and hydrogen were oxidized to carbon dioxide and water respectively before the gases were led to a burette in which they were collected over a strong solution of caustic potash, which absorbed the carbon dioxide and water to leave only nitrogen to be measured. In this test 2.5 g of Service guncotton was required to yield not more than 4.5 mg to 6.5 mg of nitrogen in 4 hours.

*Bergmann and Junk test*

22. The Will test, which is slow and cumbersome, has been succeeded by the Bergmann and Junk test (Fig. 5), which is now preferred when any question arises as to the stability of nitrocellulose. In this test a weighed sample (2 g) of dry nitrocellulose is placed in a test tube which is fitted with an absorption bulb containing 30-40 ml of distilled water to take up the nitrogen oxides evolved during the test. The tube is then placed in a bath at 132°C for two hours. After cooling, the absorption bulb is removed and its acidic contents washed into a flask. A volume of 20 ml of N/10 hydrochloric acid is added to the test tube and shaken with the nitrocellulose for 15 minutes before being filtered into the flask containing the contents of the absorption bulb: the test tube is well washed and the washings passed to the flask through the filter, to ensure the complete transfer of all acid. Then 25 ml of N/10 caustic soda solution is added to the flask and its contents are back-titrated with N/10 hydrochloric acid. In practice, two samples of nitrocellulose are heated while a third tube contains an unheated (blank) sample of NC; all three tubes are subjected to the same analytical procedure, the back-titration of the blank being subtracted from that of each heated sample. From these results the amount of nitrogen evolved from each heated sample is calculated (in mg per g of sample) by means of a formula.

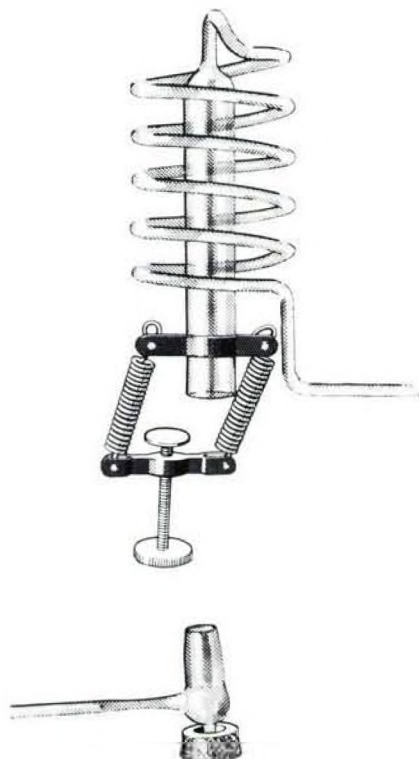

Fig. 4 Combustion tube for Will test



Fig. 5 Test tube and Absorption Bulb for Bergmann and Junk Test

*Woolwich test (for single-base propellants)*

23. This test is employed for single base propellants, normally stabilized by diphenylamine. A quantity of the propellant is placed in an open glass tube, jacketed by a second tube, and stored at 80°C in an atmosphere of 95% relative humidity for three weeks, after which the stabilizer content of the

propellant is reassessed. It should not have fallen below a specified proportion of its initial value. Because it takes three weeks to perform, the test is not suitable for routine inspection purposes, and its chief use is as one of the investigations which may follow an abnormal result arising from the Heat Test (para. 13) on a propellant.

#### *Methyl violet test*

24. While the American methyl violet test has been used in the British Service for the surveillance of ballistite in tropical stations, it is now primarily of interest for testing nitrocellulose and single-base powders and other propellants for which comparison must be made with American standards of stability. It is performed in much the same way as the Heat Test (para. 8), but using standard methyl violet test papers, test temperatures of 120°C or 134.5°C and samples of 2.5 g. Five sample tubes are used for each test and the shortest time required for the complete change of colour to salmon-pink of the test paper in any one of the tubes is recorded. Heating is continued and the time for any one of the tubes to be completely filled with brown fumes (of  $N_2O_5$ ) is noted. Heating may be further continued to note whether explosion occurs in any tube in less than 5 hours. In general, the test is performed at the higher temperature for nitrocellulose and single base powders, for which colour-change times range from 40 to 90 minutes and fuming times from 60 to 160 minutes. Double base propellants are usually tested only at 120°C, when they give times from 55 to 100 minutes for colour change and from 75 to over 300 minutes for fuming. Cordites MD and N, however, give times of 30 and 35 to 40 minutes respectively for colour change at 134.5°C and do not explode in less than 5 hours.

#### *Colour test for carbamate cordites*

25. Once a propellant of nitric ester type has been made, its stabilizer content begins to be consumed by interaction with the products of decomposition of the nitric esters (usually, of course, nitrocellulose and nitroglycerine), and at any time its remaining Service life will depend on the amount of residual unconsumed stabilizer. When carbamate (a pale coloured compound) is used as stabilizer it forms coloured compounds with the oxides of nitrogen liberated by the nitric esters, and these are best seen if a sample of the propellant is dissolved in acetone, when the colour can be compared with that of a suitable standard, using a colorimeter. The darker the colour of the acetone solution the less is the amount of unchanged carbamate remaining. On considerations of safety it is usual to 'condemn' a cordite when only half of its original carbamate remains.

26. In carrying out the test (see Army Ordnance Services Regulations, Vol 4, Pamphlet 23) the colour of a solution of one gramme of cordite in 50 ml of acetone is matched against that of a standard colour solution (Standard Colour Solution No 25), made up as follows:—

Potassium dichromate ( $K_2Cr_2O_7$ )	1.2 g
Cobalt ammonium sulphate ( $CoSO_4 \cdot (NH_4)_2SO_4 \cdot 6H_2O$ )	32.7 g
Conc. sulphuric acid ( $H_2SO_4$ )	12.5 ml
— all dissolved in distilled water to 1 litre.	

27. The colour of the standard solution representing the acceptance limit is that of a 'half carbamate value' cordite, and the colour of the cordite solution should not be more intense than that of this standard solution. The standard can, of course, be diluted if the test is being applied to a cordite which has not degraded to an extent approaching that of 'half carbamate life'. The standard colour solutions are being replaced by Lovibond comparator discs containing suitably coloured glass panels.

#### *Nato test for propellants*

28. STANAG 4117 describes standard methods for the determination of residual stabilizers (diphenylamine and carbamate) in propellants. Sentencing is based on the change in stabilizer content when samples are kept at 65.5°C for 60 days and the propellant is adjudged to have a residual life of at least 5 years if the following conditions apply where percentage values are relative to propellant mass:

- (1) *Diphenylamine stabilized propellant* The fall in stabilizer content during the heating period does not exceed 0.5% and at least 0.3% diphenylamine remains at the end of the test.
- (2) *Carbamite stabilized propellant* The fall in stabilizer content during the heating period does not exceed 1.0%, or at least 50% of the residual carbamate content remains and this residual stabilizer content is not less than 0.3%.

#### *Dewar-vessel test*

29. The Dewar-vessel test is primarily of value for pyrotechnic compositions which are liable to undergo reaction with evolution of heat due to the presence of small amounts of moisture which may be contained in the ingredients of the composition or which may be added deliberately to ascertain their effect. But it is a test procedure which can also usefully be employed under appropriate conditions to look for reactivity with heat evolution in other systems.

30. When testing pyrotechnic compositions, a small Dewar vessel is fitted with a rubber bung through which a thermometer passes so that its bulb will be well covered when 50 g of the composition is placed in the vessel. With that quantity in the vessel, 5 ml of distilled water is added and stirred in. [Caution: The effect of water on the composition will first have been ascertained by *ad hoc* experiment to ensure that it is not too violent!] The bung is then put in place and the temperature noted at intervals. In some instances it may rise above 100°C in a minute or two; in others it may rise only a degree or two in five or six hours. Note: the bung is lightly positioned and its purpose is to prevent the ingress of the atmosphere into the flask and to position the thermometer.

31. Compositions whose temperature rises rapidly in this test may be dangerous in manufacture unless extreme care is taken to ensure dryness. Some compositions (for example, mixtures of calcium silicide, hexachloroethane and zinc oxide) evolve no heat under the conditions of this test, but do so rapidly (and may ignite) if compressed in presence of a proportion of water such as that used in the test. Similarly, some magnesium compositions employing the powdered metal coated with waxes, drying oils, etc (Chapter 10) do not react in the loose form with small amounts of moisture which may be present due to atmospheric conditions, and react only slowly with added water in the Dewar-vessel test, but begin to evolve hydrogen when compressed.

#### Environmental tests

32. Tests such as those described in the preceding paragraphs are valuable in screening an explosive or a combination of explosive and other material with which it may come into contact to ascertain its potential for Service use. But the tests have limitations, primarily because of the small quantities used and the physical form of the material tested and the somewhat extreme temperature conditions often employed in order to shorten the time of the test. [Because of these limitations, explosives need not necessarily be condemned as unsuitable for the Services on the basis of any one test alone and this applies particularly to propellants. Doubtful cases should be referred to DQA(Mats).] When suitably screened materials have been chosen for a weapon development it becomes necessary to study in more detail their ability to withstand the environmental conditions which they may meet in Service. Such a study is a continuing requirement in the development of a weapon.

33. Obviously, the Services prefer that all their equipment should be suitable for use or storage anywhere in the world for indefinite periods. However, having regard to the technical problems of designing all items of equipment to withstand the widest extremes of climate and to the cost in many instances of achieving such perfection, it has been agreed to limit the range of climatic conditions to be withstood by restricting the use and storage of equipment to specified geographical areas and at the same time recognizing that in those areas climatic extremes occur very seldom or only for short periods on each of three or four days in a year. On this basis Defence Standard 00 — 1 has been prepared to define the various extreme climatic conditions to which military equipments may be exposed in operation, in storage and/or in transit on the ground; the categories of conditions have been selected as representative of the extremes of distinctive types of climate to be found in the world. Nine categories have been established; six of these are defined with temperature as the principal consideration, and three with high humidity, accompanied by relatively high temperature, as the outstanding characteristic. Of course, considerations of temperature must allow for such factors as incident radiation (which is measured by a blackened thermocouple enclosed in a glass dome) and which includes direct sunlight, diffused radiation from the sky and radiation reflected from the clouds. Other factors taken into account are rainfall, snowfall, wind, blowing snow, blowing sand, blowing dust, and barometric pressure as well as the effect on temperature of height.

34. Defence Standard 00 — 1 is a general document covering all sorts of equipment, for which it defines various types of failure. Liability to reversible failure (in which the store regains its properties after recovery from the extreme condition) is usually acceptable provided that the store does not become unsafe at any stage, but this is a "saving clause" which the explosives technologist will endeavour to avoid invoking — the ammunition should function safely and efficiently under any conditions under which the launching equipment (rocket launcher, gun, rifle, etc) may be used.

35. Defence Standard 00 — 1 has been quoted as laying down the conditions which military stores must comply with on the ground. Naval requirements are less likely to invoke the colder conditions; but some aircraft equipment may have to withstand aerodynamic heating, and some other special munitions may be required to meet environmental conditions of more limited range than those of the Defence Standard.

36. The effects of cold on an explosive, or combination of explosive and other material, are likely to be only physical — arising from contraction or differential contraction or from sheer embrittlement. The effects of heat may be either physical or chemical or both, and to the thermal effects which produce physical changes may be added the consequences of chemical changes, for example, when evolved gases cause cracking of a propellant or explosive charge. Apart from the possible degradative effect of heat on an explosive system, consideration must also be given to the effects of the presence of moisture — either that which was associated with the conditions of filling or that which has entered the store subsequently

as a consequence of defective sealing. It will therefore be apparent that the development of a new munition store must be accompanied by thorough environmental testing, together with 'rough usage' such as the store may be expected to encounter in its Service life and such dosages of radiant heat as may be required (up to a maximum of 360 Btu per ft<sup>2</sup> hour, that is, 1140 watts per m<sup>2</sup>); the radiant heat may well prove a searching test of the bonding between charge and case wall where such bonding is called for in the design of a store.

37. The physical consequences of low temperatures are readily assessed by 'cycling' a store between normal temperature (say, 15°C — 20°C) and a temperature only a little below the lowest specified for the store, taking care first to ascertain the time required to 'soak' the store to thermal equilibrium at either end of the scale; such a test is more severe than the conditions to which a store will be subjected in Service during surface use, where temperature changes will occur quite slowly, but it approximates to the condition prevailing if a store is taken up in an aircraft and returned to ground level. The immediate physical consequences of high temperatures may also be assessed by 'cycling' a store, but a judgement of the chemical consequences calls for long-duration storage at an appropriate elevated temperature, bearing in mind that while there is a temptation to save time by choosing a temperature in excess of the maximum specified for the store (as a very rough approximation, it may be assumed that the rate of chemical change will be doubled by a 10°C rise in temperature) the nature of the chemical changes may alter as the temperature is increased, so that conditions might become unrealistic.\*

38. An extremely important test is that in which a store is subjected to diurnal cycles between 32°C (90°F) and 71°C (160°F) in conditions of high (95%) relative humidity. This will quickly reveal (in two or three days) whether the store is well sealed, while continuation of the test will reveal the endurance of the sealing system or the consequences for the explosive system(s) of its failure, with resulting ingress of moisture; these consequences are usually regrettable. It cannot be too highly emphasized that explosive stores should be properly sealed and ruthlessly subjected to cyclic hot-wet testing.

### Compatibility

39. Frequent reference has been made in this book (see particularly Chapter 11) to the question of compatibility (or, more precisely, incompatibility; that is, the interaction of an explosive substance with other materials with which it is in contact or proximity, with deleterious consequences to either the explosive or the other material) and it will be convenient now to review some of the problems which have been encountered in the development of military stores. These problems are complicated by the stringent Service requirements regarding the long life and safety of such stores, and also by the increasing complexity of some of the explosive compositions being developed and by the ever-widening range of non-explosive materials presenting themselves to the designer for use in the construction of weapon systems.

40. But first it is necessary to say something of the relevance to those problems of that ubiquitous substance water, which may have been introduced into the store in association with one or other of its components, may be the product of a degradation reaction of some material or may enter the store adventitiously at some stage in its life. Water may react directly with an ingredient of an explosive system (for example, in the hydrolysis of nitric esters, or with metals such as aluminium or magnesium), may facilitate reactions which would not otherwise occur or would occur at only an insignificant rate (for example, between magnesium and oxidizing salts in a pyrotechnic composition) or may simply act as a transport medium to convey reactive substances (for example, ammonium nitrate or nitric or nitrous acids) to other parts of a store where they may cause unwanted effects such as corrosion. It should never be assumed that materials which are compatible in the absence of water will remain so in its presence, nor that non-metallic polymeric materials will be unaffected by water indefinitely; critical tests to assess the effects of water are essential at all stages in the development of a store. The foregoing remarks regarding water are, of course, quite apart from such obvious matters as its possible effects in causing failure of initiatory and ignitory systems, in impairing the functioning of gunpowder (even to the extent of reducing it to a liquid mess) and in lowering the efficiency of propellants, especially of single-base type.

### *Compatibility of metals and explosives*

41. Metals are rarely employed in direct contact with explosive substances, partly to avoid possible chemical interactions which might result in the formation of unwanted corrosion products (for example, abrasive rust) but still more because the finishing of metallic surfaces to the high standards which would ensure freedom from undesirable roughness is a costly operation. When it is required for one reason or another to bond the explosive to the metal, the intervention of some form of non-metallic material will be called for. On the few occasions when bare metals are to be employed in contact with or proximity to explosives, the designer should obtain clearance from the Explosives Research and Development

\* It may be remarked that as a result of lack of ventilation, test-temperature cycles for storage may have a more extreme effect on explosives than those encountered under actual operating conditions and suitable allowances for this effect may have to be made.

Establishment, just as, indeed, he should on the much more frequent occasions when non-metallic materials (paper, fabrics, rubbers, plastics, adhesives, varnishes, cements, lutings and greases) are to be so employed.

*Compatibilities of various explosives*

42. Some notes will now be given regarding particular incompatibilities which may arise in dealing with different classes of explosives.

43. *Primary explosives*: Obviously, great care must be taken to prevent these sensitive explosives from becoming contaminated with foreign matter, whether directly or by contact with a material of construction, whereby their sensitivity might be enhanced. It may be equally important to ensure that their 'legitimate' sensitivity is not reduced, as may happen if they are not sealed against the atmosphere of an assembly which contains plastics, rubbers, etc, which may give rise to the vapours of organic compounds of relatively low molecular weight such as solvents (from varnishes), formaldehyde and phenols (from thermosetting resins) or styrene (from polyester/styrene rubber).

44. It will be recalled from Chapter 9 that mercury fulminate is incompatible with aluminium, and that moisture markedly reduces its life at high temperatures. It was also recorded that lead azide is incompatible with copper and copper alloys, which combine with the hydrazoic acid released in the reaction of lead azide with water. It is often said that lead azide is incompatible with shellac varnish, but this is less a matter of incompatibility of the azide with shellac than of hydrolysis of the azide by the water present in the methylated spirit with which such varnish is made and which does not wholly disappear as the varnish dries off. Silver azide, while unaffected by moisture, is incompatible with sulphur compounds, tetrazene and some metals (for example, copper).

45. *Secondary explosives*: Although picric acid is now obsolete as a military explosive, it may nevertheless be useful to refer again to the necessity of maintaining 'lead-free' conditions in its use, since ammonium picrate is employed in British plastic propellants; 'lead-free' conditions imply the presence of not more than 0.03% of lead in any material with which picric acid or picrates may come into contact (in order to minimize the risk of formation of the sensitive lead picrate).

46. TNT and tetryl are incompatible with alkaline conditions, which result in the formation of red compounds of an iso-nitrolic acid structure.

47. PETN is incompatible with amatols, the ammonium nitrate content of which may, under adverse conditions (hot-wet), give an acid reaction which would catalyze the hydrolytic degradation of the PETN. By the same line of reasoning it may be seen that pentolite must be employed in neutral conditions; the alkalinity which is favourable to the stability of PETN is incompatible with the TNT, while a degree of acidity which is harmless to TNT is adverse to the stability of PETN.

48. The low melting point of TNT, which is so useful in filling operations, renders it necessary to be very careful not to bring TNT or compositions containing it into contact with anything soluble in TNT whereby its melting point would be reduced, with consequent risk of 'exudation' which may contaminate other parts of the store, resulting in danger of malfunctioning.

49. TNT tends to migrate into rubbers and some other polymers, often causing severe physical deterioration in them; it is unlike tetryl, which is generally without effect on such materials.

50. Tetryl is incompatible with sulphur, and so with gunpowder and with compositions containing sulphides (for example, antimony sulphide).

51. Ammonium nitrate is particularly susceptible to carbonyl compounds (for example, formaldehyde arising from some synthetic polymers) and to alkalinity. The former give rise to acidity and the latter to the evolution of ammonia, which is incompatible with TNT and tetryl and may attack copper alloys.

52. Reducing metals, such as zinc, are incompatible with all nitro- and nitrate- compounds.

53. Explosive compositions containing finely-divided aluminium (especially those including ammonium nitrate must be made under thoroughly dry conditions and kept dry, otherwise slow reaction between aluminium and water will occur, giving rise to (flammable) hydrogen which may render a filled store dangerous (the charge may be cracked; the gas pressure may 'blow' sealed joints, etc).

54. *Pyrotechnic compositions*: These compositions are of so widely variable nature that it is only possible to say that water is, in general, the prime source of incompatibility. In excess, water may of course render them non-ignitable; but in smaller amounts it may cause interactions, the heat from which

may result in spontaneous ignition. The risks from water-induced reactions are being reduced as the trend grows to employ synthetic polymers as fuels in place of starch, lactose, *etc.*, and to replace cellulosic containers with polymeric 'potting' compositions. But the use of polymers calls for care to ensure that they do not give rise to reactive materials or contain sulphur which may react with chlorates.

**55. *Single- and double-base propellants:*** Because both of these forms of colloidal propellants contain nitric esters, acid conditions are inimical to their stability, and since moisture tends to hydrolyze the esters, with production of acidity, its presence should be avoided, even although modern stabilizers such as diphenylamine, 2-nitrodiphenylamine and carbamite are extremely effective in absorbing acidic products of decompositions. The presence in these propellants of nitrocellulose ensures that there will always be a certain equilibrium moisture content (dependent on the nature and percentage of the NC and on the prevailing relative humidity), but other sources of moisture should be avoided.

**56.** The acid products of decomposition of such propellants, as also the ammonia which may be liberated by picrite propellants on hot storage in humid conditions, attack brass and cause it to crack, so that it is usual to protect the interior of brass cartridge cases by the use of a suitable lacquer.

**57.** While single-base propellants may be, and often are, stored in zinc-coated steel transport cases provided that they are dry, such cases cannot be used for double-base propellants because the zinc would react with the nitroglycerine vapour which is associated with them, with consequent progressive deterioration of ballistic efficiency. In this connection also it is well to remember that the vapour pressure of nitroglycerine in any enclosed space of a munition store containing a double-base propellant implies that care must be exercised with regard to the choice of any other materials which may be in that space; they must not be either chemically or physically incompatible with nitroglycerine, which will often migrate into polymeric materials with consequent ill effects on their physical properties, apart from any adverse chemical reaction. Conversely, plasticizers often used in polymeric materials may migrate into the propellant, with which they may be chemically incompatible and whose physical properties and ballistics they may impair.

**58.** Although not directly a matter of compatibility, it may be appropriate at this point to draw attention to a consequence for large charges of double-base propellants (for example, for rocket motors) of the degradation of such propellants. The end-products of such degradation are nitrogen and carbon dioxide, the former being of very low solubility in the propellant and the latter having a not very high solubility, with the consequence that the evolution of these gases may result in the cracking of the charge unless it can be so designed that the thickness of propellant at any point (web-thickness) is such as to permit of the diffusion away of the gases at a rate adequate to cope with their rate of formation.

**59. *Composite propellants:*** Insofar as these are generally compositions of a solid oxidizer (usually ammonium perchlorate, but sometimes ammonium nitrate), an energetic metal (usually aluminium) and an organic polymer which serves as fuel and binder, they are normally more stable than colloidal propellants. Adverse effects of moisture are less likely to appear as chemical than as physical consequences, notably as deterioration of mechanical properties due to degradation of the polymeric fuel-binder or of the wetting agent employed to assist adhesion of the fuel-binder to the solids. Serious ingress of plasticizers from other polymeric material with which the propellant may be in contact or in proximity will also reveal itself by a change of physical properties. Apart from these considerations, regard must also be had to the possible reaction of the ammonium salt oxidizers with carbonyl compounds and with alkaline media (see para. 51 of this Chapter).

## GLOSSARY

## Terms used in explosives technology and in the Textbook

Allotrope	One of two or more physical forms of an element which differ in molecular complexity, physical properties and chemical reactivity
Azeotrope	An azeotrope is one of the components of a mixture of substances which cannot be separated by distillation. The term is also used to describe the (constant boiling point) mixture distilled from such a system
Basic salt	A compound of an acid and a base which contains more of the latter than is chemically equivalent to the former
Blast	A destructive wave produced in the surrounding atmosphere by an explosion. It includes a shock front followed by a high pressure region which is followed by a rarefaction
Calorie	A calorie is that quantity of heat which is required to raise by 1°C the temperature of 1 gramme of water at 15°C. Its value is 4.1865 joules
Calorific value	That amount of heat evolved by the complete combustion (usually determined experimentally in an atmosphere of excess oxygen in a closed vessel) of a given weight of a combustible substance
Calorimetric value	That amount of heat evolved by the combustion or detonation of a given weight of an explosive substance in a closed vessel in the absence of added air or oxygen. It is influenced by the density of loading (that is, the ratio between the weight of the substance and the volume of the vessel) and by whether or not time has been allowed for the condensation (with evolution of latent heat) of water formed in the combustion
Catalysis	A process by which the rate of a chemical reaction is increased by a catalyst
Catalyst	An agent which increases the rate of a chemical reaction but is not itself changed in the reaction
Chapman-Jouget surface	The surface, behind the shock front, in a detonation wave at which the material is receding from the wave front at the local velocity of sound
Colloid state	A dispersion of one substance in another in which the dispersed substance (the colloid) has dimensions of the order of 0.1 μm to 0.001 μm
Compatibility	The ability of a substance or combination of substances to be in contact with an explosive without adverse physical or chemical effects on either
Deflagration	Rapid burning (in which convection may play an important role)
Detonation	An exothermic reaction wave which follows and maintains a shock front in an explosive
Element	A substance the atoms of which are all chemically identical
Endothermic reaction	A chemical reaction accompanied by the absorption of heat from the surroundings
Environmental storage	The storage of an explosive or explosive system under artificial conditions designed to simulate those to which it might be submitted in Service
Eutectic	A mixture of two or more substances which has the lowest melting point of any possible mixture of its constituents
Exothermic reaction	A chemical reaction accompanied by the evolution of heat to the surroundings
Explosion	A violent expansion
Gramme-molecule	The quantity of a substance whose mass in grammes is numerically equal to its molecular weight
Group	An atom or system of atoms which persists throughout a chemical reaction or series of reactions
Heat of combustion	The amount of heat evolved in the combustion of one gramme-molecule of a substance in excess of oxygen
Heat of formation	The amount of heat evolved or absorbed in the formation of one gramme-molecule of a compound from its elements

RESTRICTED

High explosive	A secondary explosive used as a detonatable filling for shell, bomb or warhead
Hot spot	A term used in explosives technology to describe a small region in an explosive substance characterized by a temperature much higher than that of its surroundings
Hydrolysis	The decomposition of a compound by water in which a hydrogen atom of the water attaches itself to one part of the compound while the residual hydroxyl group of the water attaches itself to the remainder of the compound, so that the original compound with the water gives rise to two new compounds
Hygroscopicity	The property of a substance of absorbing and retaining water from the atmosphere
Inhibitor	A substance employed to prevent or hinder a chemical change in a system (in particular, an adherent layer of, relatively, non-combustible material applied to part of the surface of a propellant to prevent burning at that surface)
Life	(1) the period of time during which an explosive or explosive system endures storage <i>under given conditions</i> without serious adverse chemical or physical effect (2) the period of time during which a military store remains fully functionally efficient (Service life)
Molecule	The smallest particle of an element or compound capable of existing alone and still exhibiting all the chemical properties of that element or compound
Munroe (or Neumann) effect	A concentration of the explosive effect of a detonation by shaping the explosive charge
Nitric ester	A compound of the type formed by the reaction with nitric acid of an organic compound containing a hydroxyl group ( $-OH$ ) which is then replaced by a nitrate-group ( $-O\cdot NO_2$ )
Nitro-compound	A compound of the type formed by the reaction with nitric acid of an organic compound containing a replaceable hydrogen atom which is then substituted by a nitro-group ( $-NO_2$ )
Nitrolysis	A reaction (by analogy with hydrolysis) in which a chemical bond is broken by nitric acid with attachment of the positively charged nitro-group ( $-NO_2^+$ ) to one part of the reactant molecule and of the negatively charged hydroxyl group ( $-OH^-$ ) to the other part (see Chapter 6)
pH	The logarithm to the base 10 of the reciprocal of the concentration in gramme-ions per litre of hydrogen ions in a solution. The pH scale extends from 0 to 14 and covers all known aqueous solutions. Pure water has a pH of 7; acids have pH values less than 7 and alkalies have values greater than 7.
Polymer	A chemically bonded aggregation of molecules
Polymorphs	Forms of a substance chemically the same, with different X-ray patterns and crystal structures
Primary explosive	A sensitive explosive which is readily brought to ignition or detonation by mechanical or electrical stimuli
Propellant	An explosive capable of producing at a controlled rate, gases to do work (for example, propel a missile, or start an engine)
Pyrotechnic	A mixture of oxidizing and fuel agents which are capable of reacting exothermically. Such mixtures are used to produce heat, light, smoke, gases and to provide delays
Rate of burning	The linear rate of regression of a plane burning surface. It is usually measured in terms of inches (mm)/second for propellants and second/inch(mm) for pyrotechnics
Reaction zone	The region between the shock front and the Chapman-Jouget surface in a detonation wave
Secondary explosive	An explosive which can be made to detonate when initiated by a shock front or detonation wave but which does not normally detonate when heated or ignited
Sensitiveness	A measure of the relative ease with which different explosives may be ignited or initiated by a prescribed stimulus

Sensitivity	A measure of the relative ease with which reliable functioning may be assured in different explosives or explosive systems under the intended conditions of use
Shock front	A discontinuous change in the pressure and other parameters of a medium, propagated at supersonic speed
Shock wave	A shock front together with its associated phenomena (see blast)
Specific heat	The quantity of heat which unit mass of a substance requires to raise the temperature by one degree. The specific heat of a gas differs according to whether the determination is made at constant pressure or constant volume; the ratio $C_p/C_v$ of the specific heats is a physical constant of the gas and is denoted by $\lambda$
Specific impulse	The thrust per unit rate of propellant mass consumption
Stabilizer	A substance which prevents or reduces auto-catalytic decomposition of explosives
Stability	The property of continuing to exist without chemical or physical change
Thermal explosion	Explosion resulting from exothermic reaction in an explosive charge in a region in which heat is liberated more rapidly than it is taken away
Unsaturation	A term principally used in connection with organic compounds in which one or more pairs of adjacent carbon atoms are linked by double or triple bonds so that the compound is capable of combining with elements or with other compounds by addition at such bonds
Velocity of detonation	The rate at which a detonation wave progresses through an explosive. When, in a given system, it attains such a value that it will continue without change, it is the 'stable velocity of detonation' for that system
Vivacity (or quickness)	A property which is proportional to the mass rate of burning of a gun propellant of a given geometrical form and burning at a given pressure (see Chapter 12)

## BIBLIOGRAPHY

(a selection of useful references)

*General Chemistry*

- General and inorganic chemistry Partington 3rd Edn Macmillan, 1958  
 Organic chemistry Turner and Harris Longmans, 1952  
 Encyclopaedia of chemical technology Kirk and Othmer 2nd Edn Interscience Publishers, 1965  
 Dictionary of applied chemistry Thorpe and Whitely 4th Edn Longmans, 1937  
 Dictionary of organic compounds 5 vols and later supplements  
 Ed. I Heilbron, A H Cook and others, Eyre and Spottiswoode, 1965  
 Beilstein's Handbuch der Organischen Chemie 31 vols Springer Verlag, various dates

*Explosives*

- Chemistry and Technology of explosives 3 vols Urbanski Pergamon, 1964 - 7  
 Chemistry of powder and explosives Tenney L Lavis Wiley, 1943  
 Explosives (2nd Edn 3 vols) Marshall Churchill, 1932  
 Military explosives Tech Manual No 9 - 1300 - 214 US Dept of Army, 1967  
 Modern explosives W Taylor Roy Inst of Chemistry Monograph No 5, 1959  
 Explosives terms and definitions Ministry of Defence (Army), A 32/ARTS/R&D/678, 1968  
 High explosives and propellants S Fordham Pergamon Press, 1966  
 Explosives W H Rinkenbach Kirk and Othmer Encyclopaedia of Chemical Technology,  
 Volume 8, pages 581-658, 1965

*History of Explosives*

- A history of Greek fire and gunpowder Partington Heffer, 1960  
 Patent abridgements Firearms and other weapons, Ammunition and accoutrements, 1588 - 1858  
 Commissioners of Patents, 1859  
 Rise and progress of the British Explosives Industry Ed. E A Brayley  
 Hodgetts Whittaker and Co, 1909

*Properties of Explosives*

- Science of explosives 2 vols Ministry of Supply, 1956  
 The initiation of explosives Bowden and Yoffe Camb Univ Press, 1952  
 Detonation in condensed explosives J Taylor Clarendon Press, 1952  
 The science of high explosives M A Cook Reinhold, 1958  
 Theory of detonation Zeldevitch and Companeets Academic Press, 1960  
 Detonics of high explosives C M Johansson and P A Pearson Academic Press, 1970  
 Underwater explosions R H Cole Dover Publications, 1965  
 Explosive shocks in air G Kinney Macmillan, 1962

*Propellants*

- Solid propellants and exothermic compositions J Taylor Newnes, 1959  
 Energetics of propellant chemistry Siegel and Schieler Wiley, 1964  
 Joint Services Textbook of Guided Weapons  
 Part 5 CD 1141E Solid propellants for rockets — colloidal (CD) 1955  
 Part 6 CD 1141F Solid composite propellants for rockets (CD) 1959  
 Part 7 CD 1141G Liquid propellants for rockets (CD) 1954  
 Ministry of Defence  
 Internal ballistics HMSO, 1951  
 Propulsion and propellants Pamphlet ORDP 20-282 US Ordnance Corps  
 High explosives and propellants S Fordham Pergamon Press, 1966  
 Rocket propellant handbook B Kit and D S EVERED Macmillan, 1966  
 Propellant manufacture, Hazards and testing American Chemical Society,  
 Advances in Chemistry Series No 88, 1969  
 Advanced propellant chemistry Advances in Chemistry Series No 54  
 American Chemical Society, 1965  
 Fuels and new propellants Ed. C. Casci Pergamon Press, 1964  
 Chemical rockets and flame and explosives technology — R T Holtzmann — Marcel Dekker, 1969  
 Rocket propulsion N H Langton University of London Press, 1970  
 Propellant chemistry S F Sarmer Reinhold, 1966  
 Solid rocket technology M Shorr and A J Zaehring John Wiley, 1967  
 Rocket propellants F A Warren Reinhold, 1958  
 Explosives (propellants) V Lindner Kirk and Othmer Encyclopaedia of Chemical  
 Technology, Volume 8, pages 659-719, 1965

*Pyrotechnics*

- Monograph on pyrotechnic compositions (R) Cackett RARDE, 1965  
Textbook of Air Armament, Part 4, Chapter 10, Design of pyrotechnics (R)  
AP 110A - 0300 - 1D10 Ministry of Defence, 1959  
Modern pyrotechnics H Ellern Chemical Publishing Co, 1961  
Pyrotechnics H Ellern Kirk and Othmer Encyclopaedia of Chemical Technology,  
Volume 16, pages 824-840, 1968  
Chemical warfare, pyrotechnics and, the fireworks industry T F Watkins and others  
Pergamon Press, 1968

*Safety*

- Guide to the Explosive's Acts, 1875 and 1923 HMSO, 1941  
Redgrave's Factories Act 21st Edn Butterworth, 1966  
Dangerous properties of industrial materials SAX Reinhold, 1963  
NATO safety principles for the storage of ammunition and explosives  
NATO unclassified document AC/258-D/70  
Explosives regulations AP 110A - 0102 - 1 Ministry of Defence, 1971  
Prevention of and protection against accidental explosion of munitions, fuels and other hazardous  
mixtures Ann N Y Acad Sci, Vol 152, Art 1, 1968  
Explosives hazard assessment manual of tests Sensitiveness Collaboration Committee SCC  
No 3 issued by ERDE Waltham Abbey  
Explosives industry; and explosives substances Sections in the Encyclopaedia of  
occupational health and safety ILO, 1971

*Materials*

- Encyclopaedia of polymer science and technology Interscience Publishers, 1964  
Polymer handbook Interscience Publishers, 1966  
British plastics yearbook (annually) Hiffe Books Ltd  
Modern plastics encyclopaedia (annually) Modern Plastics (NY)  
A manual of sealing compositions for ammunition: lutings, cements, adhesives, varnishes and  
greases (ref XR 350/13) ERDE (MOD), 1956  
Cellulose and cellulose derivatives Ed Ott, Spurlin and Grafflin Interscience Publishers, 1954  
Cellulose chemistry Heuser Wiley, 1944  
Introduction to the chemistry of cellulose March and Wood Chapman and Hall, 1938  
Technology of cellulose esters Worden and Spon 1923  
Researches on cellulose Cross and Bevan Longmans, Green, 1906  
Cellulose nitrate F D Miles Oliver and Boyd, 1955  
Boron hydrides Lipscomb Benjamin, 1963  
Boron, metallo-boron compounds and boranes Ed Adams Interscience Publishers, 1964

## Index

(First figure is the Chapter No.; Second figure is the paragraph No.)

- Abel, Frederick 2 — 13, 36, 46, 73; 12 — 10; 15 — 8  
 Acetone 2 — 46  
 Acid recovery 5 — 21  
 Additive constants (propellant compositions) 12 — Table A1  
 Adhesives 11 — 53  
 Alkyd resin 11 — 4  
 Aluminized compositions 2 — 68; 7 — 50; 8 — 61  
 Aluminium 2 — 64, 68, 78; 5 — 33  
 Amatex 7 — 35  
 Amatol 2 — 19; 7 — 34  
 Ammonal 7 — 52, 60  
 Ammonia 5 — 2  
 Ammonium nitrate 1 — 16; 2 — 61; 5 — 10; 6 — 110  
     perchlorate 2 — 61, 68; 5 — 43  
     picrate 2 — 62; 6 — 11; 7 — 24  
 ANFO (ammonium nitrate/fuel oil) 7 — 67  
 Antimony sulphide 5 — 40  
 ASA composition 9 — 69
- Bachmann process (RDX) 6 — 54  
 Bacon, Roger 2 — 4  
 Bakelites — see phenol-formaldehyde resins  
 Ballistics, rocket 12 — 28  
 Ballistite 2 — 45; 8 — 40  
 Ball powder 2 — 59; 8 — 11  
 Baratol 2 — 19  
 Barium nitrate 5 — 32  
     styphnate 9 — 42  
 Biazzi process (NG) 6 — 88  
 Bickford fuze 7 — 17
- Bipropellants 1 — 11  
 Bitumen 11 — 63; 13 — 33  
 Blast 1 — 7; 7 — 53; 55; 13 — 19  
 Blasting gelatine 2 — 44; 7 — 62  
 Bomb fillings 13 — 9  
 Boranes 5 — 56  
 Boron 5 — 34  
 'Breathing' of stores 15 — 38  
 Brisance 1 — 7; 13 — 17  
 Burning rates 4 — 1; 10 — 15; 12 — 2  
 Burning to detonation 13 — 6
- Calcium cyanamide 6 — 110  
 Calorimetric value 4 — 61, 66  
 Cap composition 2 — 71, 72; 9 — 60  
 Carbamite 2 — 47, 51; 6 — 113; 8 — 20, 39, 85  
 Carbon black 7 — 44  
 Cartridge cases, combustible 11 — 42  
 Case-bonded propellants 12 — 48

RESTRICTED

- Cellulose (cotton) 2 — 34; 6 — 65; 11 — 24
  - (wood) 2 — 34, 51; 6 — 65; 11 — 24
  - acetate 8 — 50; 11 — 34
- Chapman and Jouget 4 — 51
- Charcoal 2 — 4, 9; 5 — 25
- Clean areas 14 — 23
- Closed vessel 12 — 20
- Compatibility 1 — 17; 11 — 18; 13 — 11; 15 — 39
- Congreve, Major 2 — 10
  - Sir William 2 — 10; 79
- Coolants 6 — 112
- Cordite (see propellants) 2 — 46, 50; 8 — 19
  - compositions 2 — 46
  - flashless ('cordite N') 2 — 48
- 'Corporal' rocket 8 — 88
- Cryolites 8 — 26
- Cyanamide 6 — 110
- Cyclotetramethylenetetranitramine (see HMX)
- Cyclotrimethylenetrinitramine (see RDX)
  
- Danger buildings 14 — 7, 25
- DATB 6 — 42
- Dautriche method (detonation velocity) 4 — 63
- DEGN 6 — 103
- DEGDN 6 — 103
- Delay compositions 7 — 14; 10 — 54, 55
- De Saint Robert's rule 12 — 2
- Desensitizers 7 — 47; 13 — 12, 16, 36
- Detonating cords 7 — 18
- Detonation 4 — 1
  - velocity of 1 — 6; 4 — 62
- Detonators 9 — 68; 13 — 2
- Dextrinated lead azide 9 — 26
- Dicyandiamide 6 — 110
- Dimethylaniline 2 — 16; 5 — 14
- Dimethylhydrazine (UDMH) 6 — 122
- Dinitroresorcinols 6 — 35, 36
- Diphenylamine 2 — 58; 6 — 113; 8 — 7
- Diphenyl-diethyl-urea (see carbamite)
- Dithekite 7 — 66
- Dynamite 7 — 61
  
- EC powder 2 — 39
- EDC compositions 7 — 41; 13 — 21
- Equations of state 4 — 10; 12 — 10
- Ethyl cellulose 8 — 50; 11 — 34
- Ethylene dinitramine (EDNA) 6 — 108
- 'Exploding bridgewire' principle 13 — 8
- EXE powder 7 — 7
- Explosion 1 — 1
  - heat of 4 — 14, 66
- Explosive D 6 — 10
  - plastic 2 — 38

RESTRICTED

- Explosives 1 — 2, 3, 4
  - Acts (1875 and 1923) 3 — 1
  - 'Authorised' list 3 — 3
  - classification of, 3
  - compositions, chapter 7 and 9
    - balanced 4 — 20; 7 — 34; 8 — 64
    - heat-resistant — DATB and TATB 6 — 41
  - historical development 2
  - military, choosing 1 — 13
  - primary 1 — 8; 4 — 1; 9 — 1
  - properties 4 — 56; 14 — Annexe A
  - secondary ('high', 'HE') 1 — 6; 2 — 12; 4 — 1
  - Sprengel 7 — 66
  - Service classification 3 — Table 1
  - storage 3 — 11
- Explosive trains 13 — 2
- Exudation (cordite) 12 — 24; 14 — 39
- Exudation (TNT) 6 — 29; 11 — 47; 13 — 15; 14 — 39; 15 — 48
  
- FAX (fuel/air explosive) 7 — 68
- Figure of insensitivity (F of I) 14 — 46
- Filling techniques 13 — 25
- Flame temperature 12 — 13; 12 — Appendix 1
- Flash (muzzle or nozzle) 2 — 48; 8 — 6, 23; 12 — 55
- FNH powders 8 — 7
- Form function 12 — 14
- Fragmentation 13 — 17
- Friction compositions 2 — 73
- Fungi 11 — 22
- Fuze compositions 7 — 14; 9; 10
- Fuzes 13 — 2
- Fuzes (cord type) 7 — 17
  
- Gaine 2 — 76
- Gasless delay compositions 10 — 55
- Gelignite 7 — 63
- Glycerine (glycerol) 2 — 42; 6 — 84
- Glycols 6 — 99
  - nitrates 6 — 99
  - DEGN, DGN, DEGDN 6 — 102, 103
- Graphite 2 — 7; 8 — 15
- Greek fire 1 — 1
- Guanidine nitrate 6 — 110
- Gun ballistics 12 — 10
  - flash 8 — 6, 7, 23
  - smoke 8 — 29
- Guncotton slabs 2 — 38; 7 — 57
- Gunpowder 1 — 9; 2 — 4; 7 — 1; 8 — 2
- Gyttorp or NAB process (NG) 6 — 90
  
- Haleite 6 — 108
- Hexamine (Hexamethylenetetramine) 2 — 21; 6 — 47
- Hexanitrodiphenylamine 6 — 46
- Hexogen (see RDX)

RESTRICTED

High explosives 1 — 5 (see explosives secondary)  
High-temperature explosives 6 — 41; 13 — 35  
HMX and HMX compositions 2 — 27; 6 — 56; 7 — 41, 49  
Hollow charges 13 — 20  
Hopkinson pressure bar 4 — 75  
Hydrazine 5 — 53  
Hydrazoic acid 9 — 15  
Hydrogen peroxide (HTP) 5 — 49; 8 — 89  
Hypalon (as replacement for cellulose acetate) 11 — 34

Igniters 13 — 2  
Igniting (or priming) compositions 10 — 46  
Ignition 2 — 69  
Illuminating compositions 10 — 13  
Impulse, specific 12 — 34  
Incendiaries 10 — 59  
Inhibition of propellants 2 — 66; 8 — 50  
Initiation 1 — 8; 2 — 69  
Initiators (see explosives, primary)  
Inorganic compounds Chapter 5  
Inspection 15 — 1  
Instantaneous fuzes 7 — 17  
Isopropyl nitrate 6 — 104

Kistiakowski and Wilson 4 — 12, 33

L mixture 9 — 44, 67; 13 — 4; 14 — 50  
Lead acetate 5 — 47  
Lead azide 1 — 8; 2 — 75; 9 — 15, 26  
Lead azotetrazole 9 — 47  
Lead dinitroresorcinates 9 — 43  
Lead styphnate 1 — 8; 9 — 34  
Lead thiocyanate 9 — 65  
Lead trinitrophenylglucinate 9 — 46  
Lecithin 7 — 48  
Lightning precautions 14 — 18  
Line-cutting charge 7 — 19  
Lutings 11 — 63  
Lyddite (see picric acid)

Magnesium 2 — 78; 5 — 33; 10 — 6  
Mercuric chloride, effect of heat test 15 — 11  
Mercury 5 — 36  
    fulminate 1 — 8; 2 — 70; 9 — 6  
Mesonization 12 — 43  
Mettegang apparatus (detonation velocity) 4 — 63  
Methyl centralite 6 — 113; 8 — 15  
    methacrylate (Perspex) 11 — 35  
    nitropropanediol 6 — 106  
Mineral jelly 2 — 46, 47; 8 — 20  
Minol 7 — 53; 13 — 32  
Mixed acid 5 — 19  
Moderants 2 — 52; 6 — 116; 8 — 14  
Moisture, effects of 1 — 16

- Monopropellants 1 — 11
- Multitubular propellants 8 — 5; 12 — 26
- Muraour 12 — 9
  
- Nathan-Thomson-Kintoul process (NG) 6 — 88
- NCT, NCY and NCZ powders 2 — 54; 8 — 5
- NH type powders 2 — 55; 8 — 7
- Nitric acid 2 — 12; 5 — 5; 7 — 66
- Nitrobenzene and nitric acid mixtures 7 — 66
- Nitrocellulose 2 — 34; 6 — 71
  - properties 6 — 82
- Nitrogen tetroxide 5 — 14
- Nitroindene polymer (NIP) 10 — 55
- Nitroisobutylglycerine (NIBG) 6 — 106
- Nitroglycerine 2 — 42; 6 — 87; 8 — 11, 17, 20, 31, 41, 47
- Nitroguanidine (see picrite)
- Nitromethane 6 — 105
- Nitroparaffins 6 — 105
- Nobel, Alfred 2 — 43, 74; 8 — 40
- Nobel's explosives 808 and 822 7 — 64, 65
  - explosives 851 and 852 7 — 58, 59
  - rifle neonites (NRN powders) 8 — 15
  - NNN powders 8 — 18
  - NPP powders 8 — 18
- Nylon 11 — 6, 37
  
- Oleum 5 — 18
- Organic compounds, 6
- Oxamide 12 — 44
  
- Paints 11 — 42
- PBX, plastic-bonded explosive 7 — 55
- Pentaerythritol 2 — 30; 6 — 59
  - tetranitrate (PETN) 6 — 59
- Pentolite 7 — 48
- PETN 6 — 59
- Phenol 6 — 4
- Phenol-formaldehyde resin 11 — 9, 38
- Phloroglucinol 6 — 38
- Phosphorus 5 — 38
- Phthalates 6 — 112
- Physiological effects 1 — 18; 5 — 4, 9, 14, 37, 38
- Picric acid 2 — 13; 6 — 5; 7 — 22
  - powder 2 — 13; 7 — 25
- Picrite 2 — 48; 6 — 109; 8 — 25, 26
  - carbamate complex 8 — 39
- Piobert's law 12 — 2
- Plastic explosive 2 — 38
- Plasticizers 6 — 112
- Plastics 11 — 31
  - (engineering) 11 — 40
- Platonization 12 — 52, 40
- Polyisobutylene (PIB) 2 — 62; 6 — 118; 8 — 63; 12 — 49
- Polymers 8 — 59; 11 — 1

Polypropylene 11 — 6  
 Polystyrene 2 — 61; 11 — 36  
 Polythene 11 — 4  
 Polyurethanes 8 — 80, 81  
 Polyvinyl chloride 11 — 2, 35  
 Potassium chlorate 5 — 42  
     nitrate (saltpetre) 2 — 2, 6, 9; 5 — 31  
     perchlorate 5 — 43  
     sulphate as flash suppressor 8 — 7  
 Poudre B 2 — 40  
 Power (explosive) 4 — 67  
 Prematures (shell) 13 — 15  
 Propellants 1 — 9; 2 — 46, 8  
     balanced 4 — 20; 7 — 34; 8 — 64  
     bi-propellants 1 — 11  
     burning rate 12 — 2, 7, 40, 43  
     cast double base (CDB) 2 — 65; 8 — 47  
     composite 2 — 60; 8 — 58; 15 — 59  
     composite rubbery 8 — 71  
     composite-modified cast double base (CMCDB) 2 — 68; 8 — 84  
     double base 2 — 46; 8 — 19; 15 — 55  
     flashless ('triple base') 8 — 36  
     hybrid 8 — 93  
     liquid 8 — 86  
     plastic 2 — 60; 8 — 63  
     rubber 8 — 71  
     single base 2 — 39, 53; 8 — 5; 15 — 55  
 Pyro-powders 2 — 54  
 Pyrotechnics 1 — 12; 2 — 77, 10; 15 — 54  
  
 Quantity distance 3 — 13  
 Quickmatch 7 — 13  
 Quickness (vivacity) 12 — 17  
 Quinan stove 8 — 31

R mixture 9 — 44  
 Rankine and Hugoniot 4 — 39  
 Rate of burning (propellants) 12 — 2, 7, 40, 43  
 RD series materials (a selection)

(For summary of RD 1300 series, see also Chapter 9, Table 4)

RD 1154	11 — 63	RD 1205A	11 — 63	RD 1251	11 — 63
1160	11 — 63	1217A	11 — 61	1284	11 — 63
1178	11 — 63	1241B	11 — 61	1284A	11 — 63
1193	11 — 61	1242B	11 — 61	1286	11 — 61
1200A	11 — 61	1243B	11 — 61	1287	11 — 63
1200B	11 — 61	1248	11 — 61	1287A	11 — 63
RD 1303	9 — 34, 72	RD 1343	9 — 30	RD 1357	9 — 55, 56
1305	9 — 44	1346	9 — 39	1358	9 — 43
1308	9 — 43, 44	1349	9 — 39	1359	9 — 46
1320	9 — 42, 74	1352	9 — 29	1360	9 — 38
1336	9 — 32	1353	9 — 43, 74	1361	9 — 41
1337	9 — 44, 45, 67	1355	9 — 49, 50	1361B	9 — 41
1340	9 — 42			1367	9 — 38
RD 1610	9 — 65	RD 1653	9 — 72	RD 1655	9 — 72
1651	9 — 44, 67	1654	9 — 72		
1652	9 — 74				

RDX and RDX compositions 2 — 20; 6 — 48; 7 — 38; 13 — 11, 16, 27  
Resorcinol 6 — 34; 8 — 85  
Robertson, Sir Robert 2 — 36  
Rockets 2 — 10, 78, 79; 10 — 1  
Rocket ballistics 12 — 28  
Rubbers 11 — 27

### Safety 3

    certificate 14 — 4  
    distance (quantity distance) 3 — 13  
    fuze 7 — 17  
    rules 14 — 2, 3  
    screens 14 — 32  
    tests (see tests)  
Saltpetre 2 — 2, 6, 9; 5 — 31  
Schmid process (NG) 6 — 88  
Schultze 2 — 39; 8 — 5  
Schwarz, Berthold 2 — 8  
Secondary explosives 4 — 1  
Semi-solvent process 8 — 37  
Sensitizers 9 — 51  
Sensitivity 1 — 20; 14 — 42  
    measurement of 14 — 42  
Shaped charges (hollow charges) 13 — 20  
Shell fillings 13 — 9  
Shellite 2 — 14; 7 — 23  
Silicon 5 — 35  
Silicone rubbers 11 — 14, 29  
Silk 11 — 25  
Silver azide 2 — 75; 9 — 32  
Slotted tube 12 — 26  
Slowmatch 7 — 12  
Smoke compositions 10 — 36  
    rocket 12 — 55  
Sodium azide 5 — 48  
    nitrate 10 — 10, 14, 29, 33  
Solventless compositions modified 2 — 52  
    cordite (SC) 8 — 41  
Specific impulse 12 — 34  
Sprengel explosives 7 — 66  
Springall and Roberts 4 — 36  
Squash-head shell 13 — 24  
Stabilizers 6 — 113  
Stability 1 — 15; 13 — 11; 15 — 7  
Static risk 14 — 24  
Storage 14; 14 — 3, 35; 15 — 33  
Stress cracking 11 — 36  
Styphnic acid 6 — 37  
Sulphite purification of TNT 6 — 29  
Sulphur 2 — 4; 5 — 28  
Sulphuric acid 2 — 12; 5 — 16  
Surface-active agents (surfactants) 6 — 120

# UNCLASSIFIED

TATB 6 — 44  
Teflon 11 — 11  
Termites 11 — 22  
Terylene 11 — 6, 37, 40; 13 — 35, 37  
Tests on explosives  
    Velocity of detonation, Berthelot and Le Chatelier, Dautrich 4 — 63;  
    Calorimetric value 4 — 66; Power of explosive, lead block, Trauzl 4 — 67;  
    Ballistic pendulum 4 — 68; Hopkinson pressure bar 4 — 75;  
    Safety tests 14 — 42; Impact (Rotter) 14 — 44; Friction 14 — 51;  
    Mallet friction test 14 — 51; Charge oblique impact 14 — 55; Ignition 14 — 56;  
    Electrostatic 14 — 62; Rifle bullet 14 — 65; Gap test 14 — 65; Spigot 14 — 68;  
    Susan 14 — 69; Stability and compatibility 15 — 7; Heat (Abel) 15 — 8;  
    Silvered vessel 15 — 14; Vacuum stability 15 — 16; Will 15 — 21;  
    Bergman and Junk 15 — 22; Woolwich 15 — 23; Methyl violet 15 — 24; Colour (for  
    Carbamite 15 — 25; Dewar vessel 15 — 29; Environmental tests 15 — 32  
Tetranitro carbazole 10 — 51, 55  
Tetranitro-oxanilide 10 — 55  
Tetrazene 9 — 52  
Tetryl 2 — 16; 6 — 14; 7 — 26; 15 — 49  
Tetryl/TNT 2 — 16, 18; 13 — 15  
Tetrytol 13 — 15  
Thermite 10 — 64  
Thermoplastics 11 — 32  
Thermosetting plastics 11 — 38  
Thiokol rubber 11 — 14, 29  
Time-fuze compositions 7 — 14  
Titanium dioxide 5 — 41; 8 — 67  
TNT (see trinitrotoluene)  
Toluene 2 — 17, 18; 6 — 22  
Torpex 7 — 54; 13 — 26, 34  
Toxicity 1 — 18  
Triacetin 6 — 112  
Trinitromethane 6 — 107  
Trinitrophenol (see picric acid)  
Trinitrophenyl-methylnitramine (tetryl) 2 — 16; 6 — 14; 7 — 26; 15 — 50  
Trinitrophenylglucitol 6 — 40  
Trinitrotoluene (TNT) 2 — 17; 6 — 24; 7 — 31, 36  
Tritonal 7 — 53  
  
Varnishes 11 — 47  
VH2 composition 9 — 66  
Vieille 2 — 40, 53; 4 — 3; 12 — 2  
Vinyl plastics 11 — 2, 35  
Vivacity (quickness) 12 — 17  
Volatility 1 — 21  
  
W composition 9 — 33  
Water-gas equilibrium 4 — 20; 12 — 5  
Wave shock or detonation 1 — 2; 4  
Waxes No 6 and 8; 13 — 16  
Wet mixing 8 — 32  
White compound 6 — 33  
Wool 11 — 26  
Woolwich process (RDX) 6 — 48  
  
Y mixture 13 — 3  
  
Z mixture 13 — 3

UNCLASSIFIED