

UNCLASSIFIED

AD NUMBER

ADB817491

CLASSIFICATION CHANGES

TO:

UNCLASSIFIED

FROM:

RESTRICTED

AUTHORITY

E.O. 10501 dtd 5 Nov 1953

THIS PAGE IS UNCLASSIFIED

Reproduced by

AIR DOCUMENTS

Division



**INTELLIGENCE DEPARTMENT
HEADQUARTERS AIR MATERIEL COMMAND
WRIGHT-PATTERSON AIR FORCE BASE
DAYTON, OHIO**

The
U.S. GOVERNMENT

IS ABSOLVED

FROM ANY LITIGATION WHICH MAY

ENSUE FROM THE CONTRACTORS IN -

FRINGING ON THE FOREIGN PATENT

RIGHTS WHICH MAY BE INVOLVED.

REEL - C

1748

A.T.I.

41379

RESTRICTED

Faint, illegible text at the top of the page, possibly bleed-through from the reverse side.

**BEST
AVAILABLE
COPY**

*Filed loose 55-2-489
Lib of Bureau. 13 Feb 1945
X 55-2-526
7-10-44*

RESTRICTED

**NAVY DEPARTMENT
BUREAU OF ORDNANCE
WASHINGTON 25, D. C.**

To all holders of Ordnance Pamphlet 925
Change 1 is to be filed with OP 925.
Approved by The Chief of The Bureau of Ordnance

OP 925 CHANGE 1

27 December 1944

W. H. ...

1 Page Page 1

ORDNANCE PAMPHLET 925
is changed as follows:

BOMB RACK MARK 61 MODS. 6, 7, 8 AND 9

Add information contained herein to OP 925.

DISTRIBUTION

Additional copies of OP 925 Change 1 may be obtained by submitting requests on NAVORD FORM 1, ORD-
NANCE PUBLICATIONS AND FORMS REQUISITION, in accordance with the procedure outlined in OCL
V15-43 (1st Rev.), or to the nearest Ordnance Publications Distribution Center: Navy Yard, Wash. 25,
D.C.; Adak, Alaska; Mare Island, Calif.; Espiritu Santo, New Hebrides; Exeter, England; Pearl Harbor,
T.H.; Manus Island, Admiralty Islands. NAS and Distribution Center mailing addresses should be obtained
from the Standard Navy Distribution List, or from the reverse side of NAVORD FORM 1.

Standard Navy Distribution List No. 29
2 copies unless otherwise noted

1. a-d, h-j, l*.
2. a*, c, e, f, h, s.
2. l, j*, ii-kk.
3. (5 copies) a, d.
33. (5 copies) ACORNS.
4. l, i(1), j*, ii, kk.
4. (5 copies) a, d.
5. b(London only).
6. a, b.
7. f, h, j, t, u*, w, z, ff.
7. (5 copies) d.
8. d, n(SPECIAL LISTS B*, C, K, P).
10. gg, qq, ss.
10. (25 copies) nn.
11. a(BuAer, CNO, ComdMarCorps).
12. a, b.
13. g, h, j, m-q, x, cc, hh, nn, pp, ss.
13. (5 copies) r.
14. a, q.
14. (5 copies) g.

* Applicable addresses.

RESTRICTED.

O.P. 925 Ch. 1
95 sheets
Sheet 1

AVIATION ORDNANCE

BOMB RACK

MARK 51 MODS. 6, 7, 8 & 9

SERVICE MANUAL

DESCRIPTION - OPERATION
AND MAINTENANCE

(Including Ordnance Publications
previously issued on this Rack)

POLLAK MANUFACTURING COMPANY,

OCTOBER 1944.

Prepared by *R. Dangler*, Devel. Eng.

Previous Issues:
2/4/1942, 1/15/43, 2/23/43, 8/27/43, July 1944.

RESTRICTED

TABLE OF CONTENTS

	Sheet:
COVER SHEET	
TABLE OF CONTENTS	2
CUTAWAY VIEW	4
I GENERAL INFORMATION - - - - -	5
A. Identification	
B. Reference Data	
C. Modifications	
D. Stock Numbers	
E. Controls	
F. Automatic Switching	
G. General Construction	
H. Weight	
I. Capacity	
J. Installation	
K. Manufacturers' Trade Marks	
II FIELD REVISIONS - - - - -	11
A. Procedure for drilling hole for insertion of safety pin (OTI V27-43) - - - - -	11
B. Provisions for mounting bomb arming controls AN-A-1 & AN-B-1 (see a temporary method for affording) continuous duty arming.(OTI V29-43) - - - - -	13
C. Replacement of (original) non-continuous duty arming solenoids with continuous duty solenoids (OTI's V33-43, and part of V4-44) - - - - -	15
D. Cold weather operation & replacement of release solenoid cap (OTI V-39-43) - - - - -	20
E. Procedure for identifying electrical lead cables (OTI V3-44) - - - - -	25
F. Replacement of defective arming wire retainers. (OTI VII-44) - - - - -	27
G. Suggested method of ground checking while loaded (OTI V13-44) - - - - -	32
H. Maintenance of Bomb racks, MK 50 and 51 types (OTI V16-44) - - - - -	36
J. Bomb Rack, Mark 51, Mods 8 & 9 (OTI V19-44) - - - - -	45
K. Reported malfunctions & temporary corrective measures. (OCL V3-44) - - - - -	47
L. Pawl latching screws, replacement (OMI V12-44) - - - - -	54
III PROCEDURE FOR ASSEMBLING RACK - - - - -	57
A. Tools for Assembling	
B. Hook-Link Group & Release Trigger Group	
C. Release Group	
D. Arming Group	
E. Electric Receptacle	
F. "Hoist Bracket Group" or "Slot Cover Group"	
G. Pivot Pins & Lockrings	
H. Miscellaneous	

RESTRICTED

TABLE OF CONTENTS

	Sheet:
IV PROCEDURE FOR DISASSEMBLING RACK - - - - -	66
A. General	
B. Tools Required	
C. Order for Disassembling	
D. Detail Procedure	
V MAINTENANCE - - - - -	69
VI ILLUSTRATIONS - - - - -	70
Electrical Connections - - - - -	70
Manual Cable Movements & Forces - - - - -	71
Method of Latching Rack - - - - -	72
Construction of complete rack, showing principal subassemblies - - - - -	73
Hook and Link Assembly - - - - -	74
Release assembly, including adjustments - - - - -	75
Construction of release assembly - - - - -	76
Arming assembly, including wiring detail - - - - -	77
Construction of arming assembly - - - - -	78
Connector assembly - - - - -	
Trigger assembly - - - - -	79
Hoist bracket group - - - - -	80
Slot cover group - - - - -	81
Miscellaneous parts, including accessory terminal - - - - -	82
Identification of minor parts (6 sheets) - - - - -	83
VII INDEX TO CHANGES; NOTES ON CHANGES - - - - -	89
A. Index	
B. Notes	

RESTRICTED

MK 51 Mod. 7 Bomb Rack Outaway View

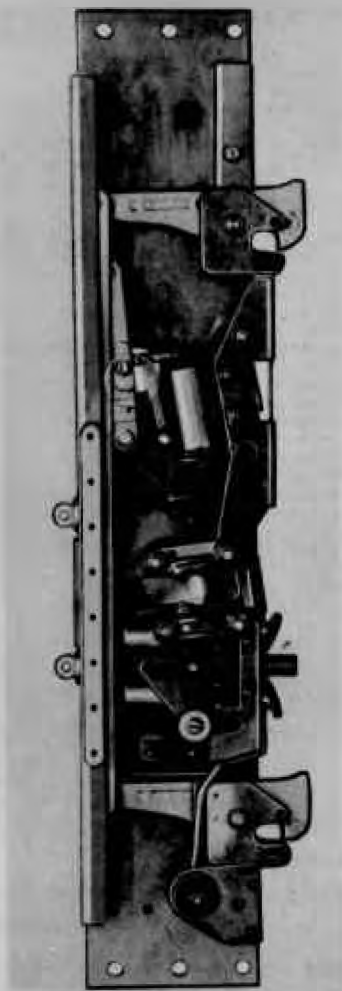

RESTRICTED

I GENERAL INFORMATION

I GENERAL INFORMATION

A. IDENTIFICATION

Mark 51 designates a 1 1/2 inch two hook bomb rack of stainless steel construction. It is interchangeable with and replaces the Mark 35's, and has additional features. It is available in 12 and 24 volt D.C. modifications, and is designed for use with the Mark 6, Mark 7 and Mark 8 portable bomb hoists.

B. REFERENCE DATA

1. Bu. Ord. Drawings, MK 51:	Mod 6 and 7	Mod 8* and 9*
Gen. Arrangement	328759	
Outline	328758	438060

2. Bu. Ord. List of Drawings:	Mod 6	Mod 7	Mod 8*	Mod 9*
	91257	91258	109454	109455

3. Applicable Publications

OTI V27-43 Drilling of holes for safety pin
 OTI V29-43 Mounting of AN-A-1, AN-B-1 Arming Controls
 OTI V33-43 Installation of contin.duty arming solenoids
 OTI V39-43 Cold weather operation of racks and installation of low temp. rel. solenoid caps.
 OTI V3-44 Identification of electrical cables
 OTI V4-44 Add'l. instructions, cont.duty arming solenoids
 OTI V11-44 Replacement of defective arm.wire retainers
 OTI V13-44 Ground checking while loaded
 OTI V16-44 Maintenance
 OTI V19-44 MK 51, Mods 8 and 9

OCL V10-43 Stock Numbers of Assemblies
 OCL V3-44 Malfunctions & correctives

OMI V12-44 Latching Screws

OP (Ordnance Pamphlet) 925, Bomb Rack MK51

C. MODIFICATIONS*

1. Voltage

- Mod 6*(i.e. 6C, 6L, 6R) is for use on 12 volt circuits
- Mod 7*(i.e. 7C, 7L, 7R) is for use on 24 volt circuits
- Conversion: The parts which differ between Mods 6 and 7 are only the solenoids in the arming and release subassemblies. It is not intended that complete bomb racks shall ordinarily be converted from 12 to 24 or 24 to 12 volt operation. In an emergency, however, it can be done. (Nameplate date should then be converted)

2. Left, Right & Center Hoisting

- Left: Mods 6L and 7L are assembled to provide for the attachment of a Mark 7 bomb hoist to the left side of the rack.
- Right: Mods 6R and 7R provide similarly for right hand hoisting.

*When available, Mod 8 replaces Mod 6 and Mod 9 replaces Mod 7.

RESTRICTED

I GENERAL INFORMATION

c. Center: Mods 6C and 7C provide for hoisting of bombs by a cable running up thru the center of the rack, between the side plates.

d. Conversion:

(1) 6L, 6R, 7L and 7R can also be used as is for center hoisting.

(2) 6L, 6R, 7L and 7R can by interchange of parts be converted to the opposite hand. This operation requires careful handling to avoid damage to insulation on cables and is not to be done frequently. See Chap. III, CP 925

3. Equivalence to Mods of MK 35

The MK 51 series racks replace the MK 35 series. The 51's have additional features, including self contained electrical equipment. However, neglecting the additional features, the 51's may be said to replace the 35's as follows:

MK 51 Mod 6L or 7L for MK 35 Mod 4
 MK 51 Mod 6R or 7R for MK 35 Mod 5
 MK 51 Mod 6C or 7C for MK 35 Mod 6

D. STOCK NUMBERS (From O.T.I. V10-43)**

1. With:

Electrical receptacle assembly on LEFT sideplate
 Hoist Bracket on RIGHT Sideplate
 Smoke Screen Tank Terminal on LEFT Sideplate forward

MK 51 Mod 6, RIGHT (R) 12 Volt Stock No. 3-R-176-65
 MK 51 Mod 7, RIGHT (R) 24 Volt Stock No. 3-R-176-75

2. With:

Electrical Receptacle Assembly on RIGHT Sideplate
 Hoist Bracket on LEFT Sideplate
 Smoke Screen Tank Terminal on LEFT Sideplate forward

MK 51 Mod 6 LEFT (L) 12 Volt Stock No. 3-R-176-63
 MK 51 Mod 7 LEFT (L) 24 Volt Stock No. 3-R-176-73

3. With:

Electrical Receptacle Assembly on LEFT Sideplate
 No Hoist Bracket
 Smoke Screen Tank Terminal on LEFT Sideplate forward

MK 51 Mod 6, CENTER (C) 12 Volt Stock No. 3-R-176-60
 MK 51 Mod 7, CENTER (C) 24 Volt Stock No. 3-R-176-70

** See Section IIJ (or O.T.I. V19-44) for Mods 8 and 9

RESTRICTED

I GENERAL INFORMATION

4. The case occasionally arises on the Mark 51 Mod 6 and Mod 7 type Bomb Racks where it is necessary to have both the Electrical Receptacle Assembly and the Hoist Bracket on the same sideplate. If such a situation exists at the activity concerned, it will be necessary for that activity to order the type Bomb Rack needed with the Hoist Bracket on the side desired. When received, it will be necessary for the activity concerned to change the position of only the Electrical Receptacle Assembly as described in Chapter Three, G.P. 923. If the situation arises wherein a large quantity of any assembly, other than those listed above is desired, an activity may submit a request to this Bureau for approval, indicating what assembly will be needed.

E. CONTROLS

1. Electric Arming. Nose and Tail Fuse Arming may be separately controlled. (Sh. 70)
2. Manual Arming. Semi-selective. Partial stroke of cable arms tail fuse; further movement also arms nose fuse. See Sheet 71 for details
3. Electric release (Sh. 70)
4. Manual release (Sh. 71)
5. Accessory terminals. Ground and "hot" terminals on side of rack for connection of smoke screen equipment carried on these racks. (Sh. 82)

F. AUTOMATIC SWITCHING

1. Automatic shunting of electric release circuit to next rack after release. (either after electric release impulse stops or after manual release force is discontinued.) (Sheets 40, 70, 75)
2. Automatic opening of indicator light switch after hooks have opened in releasing. (Sheets 40, 70, 77)

G. GENERAL CONSTRUCTION

1. Frame is of spotwelded stainless steel construction. Standard for all mods and variations. (Sh. 73)
2. Arming mechanism is an integral unit contained within a channel which fits into the frame and is mounted with two bolts. (Sheets 77, 78)

RESTRICTED

I GENERAL INFORMATION

3. Release mechanism consists of three groups of parts.
 - a. The control unit is built inside a channel mounted similarly to the firing unit. (Sheets 75, 76)
 - b. A bronze trigger and related parts provide for manual release. Mounted with one pin. (Sh. 79)
 - c. The toggle by which the hook positions are controlled is integral with the riveted hook and link assembly. This subassembly is installed with two pins. (Sh. 74)
4. All cables terminate in a receptacle which may be mounted on either side of rack, and turned to any desired position in a 180° arc. Two of the cables pass externally along the rack under a shield. The letter must be on the side of the rack opposite the hoist bracket. (Sheets 79, 80)
5. The hoist bracket, when used, is mounted with four bolts. The unused hoisting slot(or slots) in the sideplate is covered to exclude dirt. (Sheets 80, 81)

H. WEIGHT *

Mark 51 Mod 6 or Mod 7 made up for center hoisting, weighs 11-1/4 lbs.

Mark 51 Mod 6 or Mod 7 made up for left or right hoisting, weighs 11-3/4 lbs.

I. CAPACITY

1. The Mark 51's are designed to carry double fused bombs weighing from 25 to 1600 lbs. and having two support lugs at 14 inch centers, bomb lugs to have 1/2 inch maximum cross-sectional diameter and 3/4 inch minimum throat clearance.
2. Rack is serviceable after supporting 24,000 lbs. static downward load, equally divided between the hooks.
3. Other design loads are: 12,000 lbs. upward, 17,500 lbs. at 30° forward of vertically down, and 12,000 lb. aft. The last two are figured for a bomb center of gravity 7.5 inches below hook sasts.

J. INSTALLATION

1. The Mark 51's may be installed interchangeably with Navy Mark 35's, as listed under C3. The rack is mounted with 3/8 inch bolts at each end, 22.50" from front to

* No appreciable difference in wts. of mods 8 and 9

RESTRICTED

I GENERAL INFORMATION





- rear hole centers, and 1.50" vertically from hole to hole.
2. The manual control cables are located as on Mark 35 racks and may be operated by pulling in any direction in the upper hemisphere, that is, horizontally or at any higher angle. There is a slight increase in operating force as the direction of pull changes from vertical to horizontal. The cables terminate in loops fitting into grooved bushings $9/16"$ in diameter and .156 thick. The bushings have .193 diameter holes thru their centers which in normal position are $3/8$ inch above the channel on top of the rack. If desired, the bushings can easily be removed.
 3. There are cautions regarding the latching screws supplied with the rack. The thread length is critical. Improper length of thread will jam the rack or deform the latch lever stirrup. (For detail instructions, see IIIB3, sheet 59 & III, sheet 54.
 4. Electrical connection to the rack is made with a standard AN-3106-14s-5s disconnect plug. This is a socket-type plug for five conductors. The pin terminal receptacles on the rack may be swung to and clamped in any convenient position within an arc of 180° (45° less if receptacle is on hoist bracket side of rack) Release solenoid and next station lines carry about 5 amperes on 24 volt circuits (mod 7) and 10 amperes on 12 volt circuits (mod 6) all other lines carry two amperes or less. (Mod 8 same values as mod 6; mod 9 same as mod 7)
 5. When these racks are wired in series, successive pulsations of the intervalometer will operate the racks successively. ANY RACK IN SUCH SERIES CIRCUIT WHICH IS NOT LOADED WITH A BOMB MUST BE LEFT WITH HOOKS OPEN TO BYPASS THE CIRCUIT TO THE NEXT RACK. Otherwise an extra impulse in the release circuit will be required at time of bombardment to trip the empty rack. Leaving the hooks open also prevents the indicator lamp for the empty rack from lighting.
 6. Sway braces for the bomb or equipment carried must be provided on the aircraft structure.
- * Or, as an alternative, the plug connecting into the rack must be removed and inserted into a dummy receptacle which has a jumper between release and next station lines.

K. MANUFACTURERS' TRADE MARKS

1. Complete racks have been made by several manufacturers whose identification stamp appears on the frame near the nameplate. The following marks are in use:

RESTRICTED

I GENERAL INFORMATION

- a.  Pollak Mfg. Co., Arlington, N.J.
 - b.  Metel Mouldings Co., Detroit, Mich.
 - c.  American Swiss Co., Toledo, Ohio.
2. Release and erming assemblies have been made for the Pollak Mfg. Company by the following:
- a.  Bates Mfg. Co., West Orange, N.J.
 - b.  Bushler Inc., Woodridge, N.J.
3. Field reports concerning MK 51 racks should give serial number and manufacturer, as identified above.

RESTRICTED

(IIA)

II FIELD REVISIONS

II FIELD REVISIONS

This section includes the essential portions of those Ordnance publications (OTI, OCL, OMI) which have been issued relative to alterations to be made on MK 51 racks.

OTI = Ordnance Technical Instructions

OCL = Ordnance Circular Letter

OMI = Ordnance Modification Instructions

The above are arranged numerically within these groups

A. PROCEDURE FOR DRILLING HOLE FOR INSERTION OF SAFETY PIN
(OTI V27-45) (Issued 6/30/45)

1. Purpose

The purpose of this OTI is to provide the service with a means of rendering Mark 51 Type Bomb Racks "Safe" against accidental release when the airplane is not in flight.

2. Description

Activities are hereby authorized to drill a .257" hole (size "F" drill) through the side plates of the subject rack. If this size drill is not available use a 1/4" drill end ream if necessary for satisfactory fit with a 1/4" pin. The hole is to be positioned so that the insertion of a "Safety Pin" such as is used to render Mark 35 type racks "safe", will block the forward movement of the stirrup, preventing accidental release either manually or electrically.

3. Installation

Location of hole. The following procedure should be used to find the exact location for drilling the .257" hole. (See sheet 12)

- a. From the after end of the side plate of the rack, measure 10.24" forward.
- b. From the lower edge of the side plate, measure 2.125" upward. As shown on figure, this locates the hole immediately aft the stirrup, making it possible to insert a "Safety Pin" tangent to the forward end of the stirrup, thus preventing release.

4. Operation

5. Maintenance

6. Special Precautions

To check the accuracy of the location it is recommended that the following auxiliary dimensions be used:

RESTRICTED

II A and II B
 DRILLING OF SAFETY PIN HOLE &
 MOUNTING OF AN-A1, AN-B1 ARMING UNITS

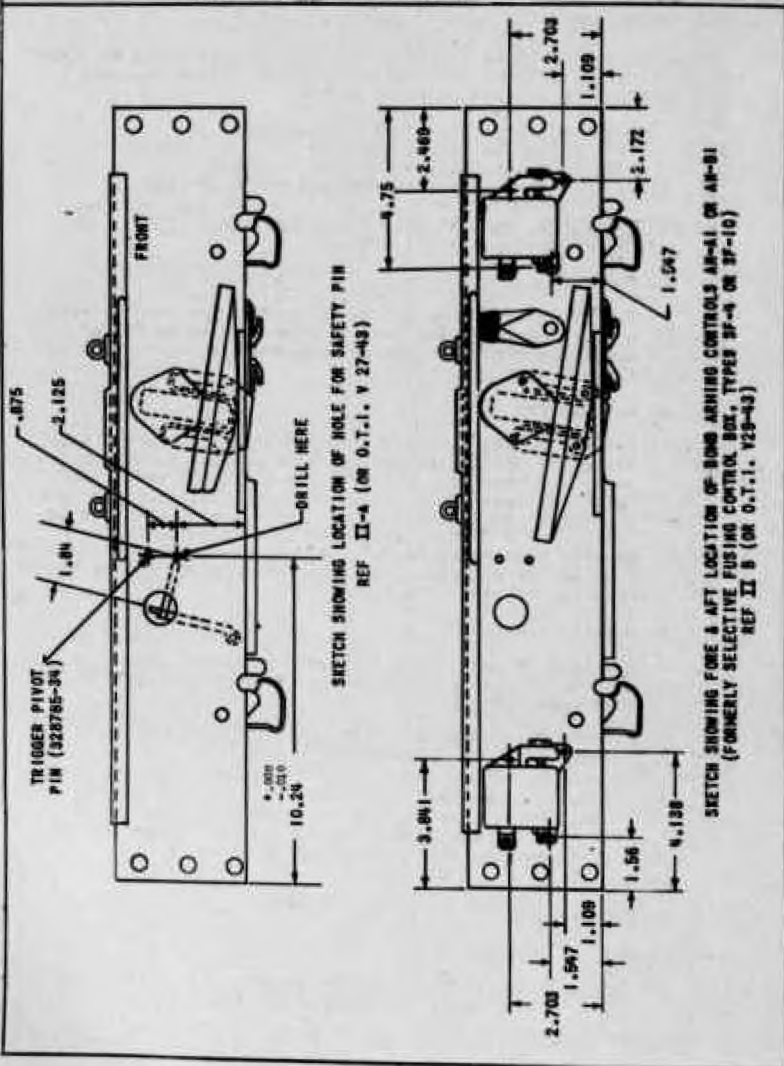

RESTRICTED

II FIELD REVISIONS

(IIR)

- a. From the center of the Trigger Pivoting Pin (BuOrd piece No. 328785-25) measure downward 0.875".
- b. Measure aft from center of Trigger Pivoting Pin 0.01". As a further check, expose the inspection hole in the rack side plates for a partial view of the stirrup (BuOrd piece No. 328771-3) and of the release lever (BuOrd Piece No. 328771-2) and check the location again as follows:
- c. From the forward face of the release lever measure 1.84" forward along the center line of the stirrup when the rack is in the latched position.

It is recommended that the rack be drilled while in the unlatched position and that the rack be thoroughly cleaned after drilling.

Note: The dimensions given in this O.T.I. do not coincide with those contained in Bureau of Ordnance airmailgram of May 20, 1943 covering this same operation. Altho the dimensions given in the airmailgram are satisfactory, it is requested that all activities that have not yet performed this operation follow the dimensions as outlined herein, which conform more closely to production tolerances.

B. PROVISIONS FOR MOUNTING BOMB ARMING CONTROLS AN-A-1 & AN-B-1 (AS A TEMPORARY METHOD FOR AFFORDING) CONTINUOUS DUTY ARMING. O.T.I. V29-43, as applicable to MK 51, issued 6/24/43

1. References

- a. Stock No. AN-A-1 Bomb Arming Control, 3-C-1805 (Identical to Selective Fuzing Control, Type SF-4 Stock No. 3-B-1970)
- b. Stock No. AN-B-1 Bomb Arming Control, 3-B-1977 (Identical to Selective Fuzing Control, Type SF-10)

2. Purpose

Reports have been received stating that the arming solenoids in the Mark 50 and Mark 51 type Bomb Racks have been burning out due to the general practice of operating with the arming solenoids energized over prolonged periods.

The purpose of this O.T.I. is to provide a TEMPORARY method for keeping bombs armed continuously when using the Mark 50 or Mark 51 type Bomb Racks. The procedure given in section C (or any later procedure that may be indicated subsequently) is preferred, and should be followed when the necessary equipment is available.

RESTRICTED

II FIELD REVISIONS

(IIE)

3. Description

The arming solenoids originally supplied in Mark 50 and Mark 51 type Bomb Racks were not designed for continuous operation. They were designed to operate continuously for a maximum of only twenty minutes. Activities encountering difficulty in this respect are requested to refrain from leaving these arming solenoids turned on longer than this period. To minimize solenoid failures, they should be turned on only just prior to use and turned off immediately following. If this cannot be done, one of the following installations is recommended, using AN-A-1 (24 volt) or AN-B-1 (12 volt) Bomb Arming Controls which are capable of continuous duty.

4. Installation

- a. Installation on Airplane Structure. - Two (2) AN-A-1 or AN-B-1 Bomb Arming Controls may be mounted directly to the airplane structure in such a manner so as to conveniently arm the bombs carried on Mark 50 and Mark 51 type Bomb Racks. This may be accomplished by means of a simple right-angle mounting flange for each Bomb Arming Control so as to provide a firm mount in a readily accessible location.
- b. Installation on Mark 51 Type Bomb Rack. - The controls may, if necessary, be mounted directly to the Mark 51 Bomb Rack by drilling three (3) holes for each control through the right side plate of the rack for mounting a control at each end of the rack. See sheet 12 for correct dimensions for locating the holes on the right side of the Mark 51 Bomb Rack. After the AN-A-1 or AN-B-1 Controls are securely mounted to the Mark 51 type Bomb Rack, disconnect the two wires in the arming solenoids and lead them out through the forward hole under the wire shield (BuOrd Dr. No. 328773-8). An insulated extension can then be soldered to the terminus of the wire sufficient in length to enable the wire to be soldered to the AN connector (3106-10a-2a). The wire marked "D" (color--white) with its extension should then be run aft under the wire shield and connected to the aft control for arming of the tail fuse. The wire marked "A" (color--brown) with its extension should be connected to the forward control for arming of this nose fuse.

When mounting the controls on racks with provisions for right-hand hoisting, the wires can be run over the top of the rack to connect on to the respective AN-A-1 and AN-B-1 Controls. The wires should be taped at intervals to the rack to prevent them from breaking loose.

RESTRICTED

II FIELD REVISIONS

(IIC)

5. Operation
6. Maintenance
7. Special Precautions

The installation of the AE-A-1 or AE-B-1 Controls on the Bomb Rack is to be regarded as temporary arrangement. The Bureau now has under development, at highest priority, a continuous operating arming solenoid intended to replace arming solenoids now built in the racks. Upon completion of extensive performance tests, and when approved by the Bureau, these solenoids will be distributed with instructions for replacing the arming solenoids in all Mark 50 and Mark 51 type Bomb Racks in stock or in service as soon as the continuous duty solenoids become available in quantity.

When securing the controls to a rack, care must be taken to insure that the bolts extending through the right side plate do not obstruct the movement of any operating parts of the rack.

The racks should be cleaned after mounting the Bomb Arming Controls to insure that no metal shavings or loose particles remain in the mechanism of the rack, and should be tested for proper operation, both manually and electrically, prior to use.

C. REPLACEMENT OF (ORIGINAL) NON-CONTINUOUS DUTY ARMING SOLENOIDS WITH CONTINUOUS DUTY ARMING SOLENOIDS*

(O.T.I. V33-43, and in paragraphs (9a), (12a) and (17a), the essential parts of O.T.I. V4-44 which was issued as a supplement to V33-43) (Both are applicable to MK 51) (V33-43 was issued 7/29/43; V4-44 on 2/14/44)

1. References

- a. Av. Ord. Stock No. 3-S-3386-50,* Continuous Duty Arming solenoids, 24 volts.
- b. Av. Ord. Stock No. 3-S-3386-25,* Continuous Duty Arming solenoid, 12 volts.
- c. O.T.I. V-29-43. (or II-B, above)

2. Purpose

The purpose of this O.T.I. is to provide instructions for replacing the arming solenoids originally included in Mark 50 and Mark 51 Type Bomb Racks with arming solenoids capable of continuous duty.

* "Revision F" solenoids should now be installed in place of those in Ref(a) and (b). See explanatory table, sect. VIIB2.(Mod 8 & 9 racks from the factory all have Rev. F. Solenoids.)

RESTRICTED

II FIELD REVISION

(IIC)

Reference (c) provides a temporary method for arming bombs continuously by mounting AN-A-1 (24 Volt) or AN-B-1 (12 volt) Bomb Arming Controls either to the airplane structure or directly to the rack.

3. Description

The continuous duty arming solenoids are of identical shape and size as the non-continuous duty arming solenoids originally supplied with the subject racks.

The continuous duty solenoids, however, will be stamped on the underside (base) with a "C", and will also bear a label on the cylindrical surface of the solenoid which will contain the following marking:

CONTINUOUS DUTY	
NOSE	12 VOLT
ARMING	24
TAIL	
SOLENOID FOR MK	50
	51

Each solenoid will come equipped with a lead wire approximately 17-1/2 inches long, and will be supplied with a terminal pin. The lead wire is of sufficient length to position the tail solenoid in Mark 50 Type Bomb Racks, the longest wire requirement for any of the four installations.

4. Installation

The following procedure is recommended for replacing the original solenoids with the continuous-duty solenoids.

a. Installation - Mark 51 Type Bomb Racks

- (1) Remove the bolt (BuOrd Dwg. No. 329209-32) that holds the electrical receptacle to the rack.
- (2) Disassemble the electrical receptacle sufficiently to remove the lead wires marked "A" (color-brown), "D" (color-white) and "C" (color-green).
- (3) Of the four (4) bolts that secure the hoist bracket to the rack, remove the lower forward bolt (BuOrd Dwg. No. 328773-25).

RESTRICTED

II FIELD REVISIONS

(IIC)

- (4) Disassemble the smoke tank terminal at the forward end of the rack to free the branch lead wire running to it from the nose arming solenoid.
- (5) Push the arming plunger to the limit of its upward travel and remove the cable bushing (BuOrd Dwg. No. 328773-28).
- (6) The arming assembly can now be slipped out from between the rack side plates.
- (7) After assembly has been taken out of the rack, the two (2) solenoids can be removed by pushing out the two (2) slip pins (BuOrd Dwg. 328785-40) that hold each solenoid.
- (8) Stamp or permanently mark a "C" on the side plate of the rack just forward of the hoist bracket and about one (1) inch up from the lower edge.
- (9) Reduce the length of the lead wires of the continuous duty arming solenoids so that they equal the length of the lead wires of the non-continuous solenoids just removed (approximately 7-1/2" for the tail and 5-1/2" for the nose arming solenoid) and resolder the terminal pin to the end of the lead wire.
- (9a) In the case of the nose arming solenoid only, make a new smoke screen branch lead, using the old smoke screen terminal lug and a 5 inch length of the remaining new cable. Make a soldered joint with the solenoid main lead at a point one-half inch from the solenoid and insulate with sleeving or rubber tape. See sketch.

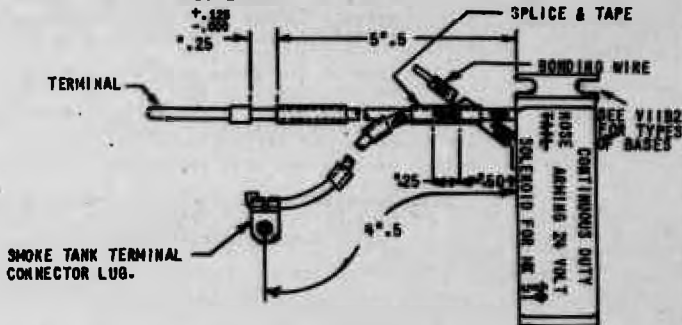

RESTRICTED

(IIC)

II FIELD REVISIONS

- (10) After adjusting the length of the lead wire for the solenoid to be used for tail arming, obliterate the portion of the label that no longer pertains to that particular solenoid; namely, "Nose" and "Mark 50", which leaves "Tail" and "Mark 51" on the label. The label of the solenoid to be used for nose arming should likewise be changed to include only the applicable marking. The incorrect voltage in each case, will have been crossed out by the manufacturer.
- (11) Insert the two continuous duty solenoids in the arming assembly and replace the slip pins removed in step (7).
- (12) Label the wire leading from the nose arming solenoid to the pin terminal "A" and the wire from the tail arming solenoid "D". The wire leading to the light switch should be labeled "C". (See section "E" with regard to labeling wires.)
- (12a) For each solenoid, solder the free end of the bonding wire supplied on the housing to the arming channel as indicated on sheet 77.
- (13) Replace the assembly in the rack, leading wires "A" "D" and "C" through the hole for the receptacle, and the smoke tank branch wire to the smoke tank terminal hole.
- (14) Pull the manual arming cable through the hole provided in the topside channel and when the arming assembly is in position, reinsert the cable bushing.
- (15) Reassemble the electrical receptacle with its wires in proper rotation and secure the receptacle to the rack again by replacing the receptacle bolt removed in step 2.
- (16) Connect the smoke tank wire (brought to correct position in step 13) to the smoke tank terminal by replacing the bolt and insulators removed in step (4).
- (17) Replace the bolt removed in step (3).
- (17a) Insulate the smoke tank terminal with rubber tape by forming a fitting of synthetic rubber cement or similar material.

RESTRICTED

II FIELD REVISIONS

(IIC)

5. Operation

The arming solenoids originally supplied in Mark 50 and Mark 51 Type Bomb Racks were not designed for continuous duty. They were designed to operate continuously for a maximum of only 20 minutes.

The continuous duty solenoids^{*} are capable of operating without interruption for at least 24 hours or for the entire length of any patrol flight without sustaining injury to the solenoid proper and without injuring any of the adjacent mechanism by unduly heating the rack.

6. Maintenance

7. Special Precautions

- a. Care should be taken to insure that solenoids of the same voltage are used to replace the non-continuous duty solenoids removed from the rack. The proper voltage is plainly stamped on each solenoid.
 - b. Care must be taken to replace the smoke tank terminal of the Mark 51 racks on the same side from which it was removed (the left-side plate). Cable must lie between guard & sideplate as shown on Sheet 82.
 - c. When assembling the electrical receptacle, care must be taken to insure that the terminals of the wires are placed in the proper holes of the upper plastic insulator (BuOrd Dwg. No. 328775-16). This insulator has five (5) holes lettered "A" "B" "C" "D" and "E". If the wires are not readily identifiable by label or color, personnel performing this work should label the wires to correspond with the proper hole in the upper insulator immediately upon removal from the receptacle. (See also section E for wire identification.)
 - d. Care must be taken not to break off the sections of the lower plastic insulator Dwg. No. 328775-17 when removing or replacing the terminals of the wire.
 - e. It is considered advisable to perform the stamping of the letter "C" onto the rack side plate while the arming assembly is removed from the rack to minimize the possibility of malfunctioning due to the impact.
 - f. The continuous duty solenoids^{*} are being used in the production of new bomb racks. These new racks will likewise be stamped with a "C" on the rack side plate in the vicinity of the hoist bracket about one (1) inch up from the lower edge as an indication that the
- ^{*}See explanatory table, para. VIIB2.

RESTRICTED

II FIELD REVISIONS

(IID)

racks are capable of continuous duty. Mark 51 type Bomb Racks assembled specifically for center hoisting only, and commonly referred to as "center assemblies" have a large "C" marked (non-permanently) on the left side plate just aft of the name plate. This "C" marking should not be confused with the smaller "C" to be permanently stamped to indicate continuous duty.

- g. Upon completion of the installation, the rack should be tested, both manually and electrically for proper operation prior to use.
- h. Care must be taken to assure that the lead wire of the continuous duty solenoid is equal in length to the lead wire of the solenoid which it is to replace.
- i. Care should be taken to insure use of the correct stock numbers when ordering continuous duty solenoids (3-S-3386-50 for 24 volt units and 3-S-3386-25 for 12 volt units). As will be noted in paragraph 4 (a) (10) above, no distinction is made between nose or tail arming solenoids or between solenoids to be used in Mark 50 or Mark 51 type Bomb Racks until the time of installation.

D. COLD WEATHER OPERATION & REPLACEMENT OF RELEASE SOLENOID CAPS*
(OTI V59-43, as applicable to MK 51) (Issued 10/5/43)

This procedure concerns the release unit principally, but it will be found convenient to carry this out simultaneously with procedures outlined in sections C, E and F.

1. Purpose

This OTI is issued for the purpose of disseminating, to the service, suggestions for improving the performance of bomb racks and bomb shackles under low temperature conditions.

2. Description

- a. Reports have been received indicating that icing may be a contributing cause of occasional hang-ups of bomb racks and bomb shackles.

- (1) The Mark 50 and 51 type bomb racks are considered decidedly superior to the Mark 41 and 35 type bomb racks and are less likely to malfunction as a result of icing, principally because of the more enclosed construction,

*See note at bottom of sheet 15

†Mod 8 and 9 racks are fitted with these caps at the factory

RESTRICTED

II FIELD REVISIONS

(IID)

fewer moving parts and improved design of these parts. Tests indicated, however, that the Mark 50 and 51 type bomb racks were sensitive to low temperatures and a principal cause was determined to be the fact that the rubber cap (Bureau of Ordnance Dr. No. 328772-7) on the release solenoid was becoming stiff at these low temperatures, thereby increasing the pull required for manual release, occasionally preventing electrical release, and also making the racks stiff to latch. The reasons are apparent from an operational study of these two racks.

- (2) In addition test reports on the Mark 50 type bomb rack indicates that there is a possibility that an excessive amount of Tectyl within the rack mechanism can cause the rack to slow up or fail to release at low temperatures. This is more important with Tectyl No. 506 than with Tectyl No. 502 since the former is a heavier compound with a higher viscosity. It is pointed out that Tectyl is a polar compound and has a definite affinity for metal and that only a film of the compound is necessary for it to fulfill its purpose. There is little to be gained from the standpoint of additional protection against corrosion by use of a thick coating of Tectyl. A general changeover has recently been made in the production lines from Tectyl No. 502 to Tectyl No. 506 to provide the better of the two corrosion preventatives on the racks and shackles leaving the factory.

SEE
NOTE
BELOW

NOTE: SUPERSEDING ORDER: The Bureau of Ordnance has, since the original issuance of this O.T.I., ruled against the use of Tectyl of any grade. This eliminates the uncertainty due to the thickness of film, at a slight loss in corrosion resistance. See OTI V16-44 on sheet 36 herein.

- b. A composition rubber cap has been developed for the release solenoid of the Mark 50 and 51 type bomb racks to replace the current cap, which composition cap has been determined by tests to substantially improve the performance of these two racks under low temperature conditions. Sample Mark 50 and 51 type bomb racks, whose release solenoids were equipped with these new caps, performed satisfactorily down to -60° F. This new Release Solenoid Cap (Stock No. 3-C-665) is being introduced into production lines immediately. These new composition rubber caps may

RESTRICTED

II FIELD REVISIONS

(IID)

be distinguished from the old rubber caps either by an aluminum spot on the cap or by a larger bead around the small hole in the cap. Those racks having the new rubber caps are identified by an "L" stamped on the bottom of the release assembly channel. It is suggested that, since the Mark 50 and 51 type bomb racks already in service probably must be detached from the airplane, and disassembled to install the continuous duty arming solenoids (OTI V33-43 or section C above) the new rubber caps be installed simultaneously. The steps necessary to install these caps are described in paragraph 5. Since lock rings (Bureau of Ordnance Drawing No. 328785-20) must be removed from the racks in removing the release assemblies from the racks, and such lock rings are rather easily broken or lost, spare lock rings (Stock No. 3-R-748-50) are being sent out with the new caps. A supply of the new caps and lock rings will be made available at the aviation supply annexes at Norfolk and San Diego and at major supply points at Seattle and Quonset Point. The caps and lock rings will be packed in containers containing twenty caps and twenty lock rings each. All activities desiring the subject caps should requisition them through the proper supply channels. NOTE: 3-R-748-50 IS ALSO DESIGNATED

3-R-747-150 (ITEM 28, SHEET 22)

- o. The following is recommended when the possibility of icing or of substantial sub-zero temperatures are expected.

- (1) Unless necessity dictates otherwise, use manual release of the bomb racks and shackles
- (2) Replace the release solenoid caps with the new low temperature caps in the Mark 50 and 51 type bomb racks not stamped with an "L" on the bottom of the release assembly channel
- (3) If the Mark 50 and 51 type bomb racks are equipped with continuous duty arming solenoids, leave both arming solenoids on during the expected period of icing or low temperatures as considerable heat will be transmitted to the bomb rack from these solenoids.

- (4) In view of paragraph 2 a (2), if it is suspected that an excessive amount of tectyl exists on the racks or shackles, they should be cleaned with either carbon tetrachloride or kerosene and equipped in Tectyl No. 506 following the procedure outlined in the pertinent OP covering the rack or shackle, and taking care to dip the rack or shackle for a period of not more than one (1) second and thoroughly draining off the excess fluid after dipping.

SEE
NOTE
BELOW

RESTRICTED

(IID)

II FIELD REVISIONS

NOTE: SUPERSEDING ORDER: In conformance with the current ruling by Bu Ord. against the use of any Tectyl, service activities should remove Tectyl in accordance with OTI V16-44 (Sheet 36 herein.)

9. Installation

a. To replace the rubber caps on the Mark 51 type bomb rack with the new composition caps, the following procedure should be followed:

- (1) Remove the hoist breakat bolt (Bureau of Ordnance Dr. No. 328773-25 and its self locking nut (Bureau of Ordnance Dr. No. 328771-9), which secures the lower left corner of the hoist bracket and the forward end of the release assembly.
- (2) Remove the lock ring (Bureau of Ordnance Dr. No. 328785-20) and the pin (Bureau of Ordnance Dr. No. 328785-51), which is about two (2) inches forward of the rear bomb suspension hook, and which secures the after end of the release assembly.
- (3) Remove cable bushing 328773-28 and slide the release channel assembly (Bureau of Ordnance Dr. No. 328770-2) downward as far as it will go without damage to the lead wires to the release assembly.
- (4) Slide the lever assembly (Bureau of Ordnance Dr. No. 328771-1) up and off the release solenoid plunger (Bureau of Ordnance Dr. No. 328772-9).
- (5) Remove the rubber cap (Bureau of Ordnance Dr. No. 328772-7) from the release solenoid plunger. Replace this rubber cap with the new composition rubber cap. Make sure that the large open end of the rubber cap is held securely in the slot around the inside periphery of the release solenoid. Further, the rubber cap should be so positioned that its small vent hole is downward to prevent salt water from dripping into the solenoid housing.
- (6) Reposition the lever assembly over the end of the release solenoid plunger.

RESTRICTED

II FIELD REVISIONS

(IID)

- (7) Stamp or permanently mark an "L" approximately 1/4 inch in size on the bottom of the channel holding the release assembly.
- (8) Slide the release assembly back into place between the side plates of the rack and secure it by the pin end lock ring, and the nut end bolt.

4. Special Precautions

- a. The new production Mark 50 and 51 type bomb racks, which contain the new rubber caps will be stamped with an "L", on the bottom of the release assembly channel. This "L" should not be confused with the "L" marked on the side plate of the Mark 51 type bomb rack, adjacent to the nameplate, which letter "L" indicates that the rack is assembled left hand.
- b. In case the stiffening of the rubber caps is causing malfunctions of the rack in cold weather, and the new rubber caps are not yet available, these old caps may be removed and the rack can be operated without the cap. However, this should be regarded as only an emergency procedure until the new caps are available, since the release solenoids without caps are subject to corrosion and entry of foreign matter.
- c. When installing the release solenoid cap on the release solenoid plunger, care should be taken that the small vent hole on that cap is positioned downward to prevent salt water dripping into the release solenoid housing, thus causing corrosion.
- d. Use of thick-bead caps and thin-bead caps. First low-temperature caps had 3/64 (thin) beads. Then a quantity of 3/32 (thick) bead caps were made. All 3/32 bead caps are of low temperature composition, but they are for use only when the release solenoid plunger (BuOrd 328772-9) has an angle of 25 deg. as shown below. The thick-bead caps (and 25 deg. plungers) were ruled out by Bu Ord for future production. Present low temperature caps have the 3/64 (thin) beads and are distinguished from the original non-low-temperature caps by a colored dot (either of aluminum paint or of pigment molded into the rubber). The sketches below show the combinations of caps and plungers which may satisfactorily be used on the MK 51.

NOTE:

The MK 50 rack release unit has an .015 thicker latch lever, which will effect the clearances when the combinations shown are used.

RESTRICTED

II FIELD REVISIONS

(IIR)

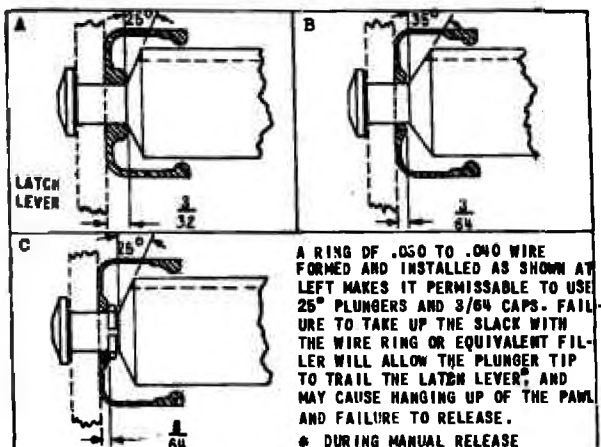

Figures A and C show infrequent combinations that may be found. Fig. B shows the normal combination. All Mod 8 and 9 racks have this arrangement, and in addition, they are fitted with an .010 beeking washer. See section VIIB5.

2. PROCEDURE FOR IDENTIFYING ELECTRICAL LEAD CABLES (OTI V3-44, as applicable to MK 51) (Issued 2/3/44)

1. Purpose

The purpose of this NavOrd OTI is to provide a positive and uniform method of identifying the electrical lead cables of Bomb Racks, Mark 51 Mods 6 and 7, where the lead cables are not identified by color in accordance with BuOrd drawing 328758.

2. Description

Drawing 328758 calls for electrical lead identification both by letter and cable color. However, a number of subject bomb racks lacking cables with proper colors were fabricated during a time of colored-cable shortage, at which time the colored-cable requirement was waived. The lead cables in these racks are, therefore, identifiable only by lettered labels of cellulose gummed taps. This Bureau has received reports that the cellulose labels are easily disfigured and subject to deterioration, thereby leaving the leads without positive identification.

RESTRICTED

II FIELD REVISIONS

(IIE)

3. Installation

The following procedure is recommended to establish identification of lead cables lacking the proper color designations in the subject bomb racks:

- a. Remove the electrical receptacle from the rack, thereby exposing the lead cables.
- b. If lettered labels are firmly attached to the cables and the letters readily discernable, they may be left in place. If not, the labels and all residue therefrom should be removed.
- c. After cleaning, apply a two-inch band of paint around the cable just below the terminal pin using the following color arrangement:

A	-----	Nose Arming	-----	Brown
B	-----	Release	-----	Red
C	-----	Light Switch	-----	Green
D	-----	Tail Arming	-----	White
E	-----	Transfer Switch	--	Black

These letter-color designations correspond to those shown in Bu.Ord. Outline drawing 328758 and are the same for both the Mark 50 and Mark 51 type Bomb Racks.

- d. As a further aid in identifying the leads, the metal terminal pins may also be painted with the above colors up to and including the $3/16$ " long terminal pin shoulder. The contact surface of the terminal pin above the shoulder should be kept clean and free from paint.

4. Operation

5. Maintenance

It is requested that the lead cables of the subject racks be checked for conformity to the color arrangement herein included whenever the racks are disassembled for maintenance or inspection reasons, and that the procedure outlined above be carried out where applicable. It is not considered necessary to disassemble the racks specifically for the purposes of this NavOrd OTI. It is suggested that a chart of the proper letter-function-color designations be posted for ready reference at all locations where the subject racks are normally disassembled.

RESTRICTED

(IIF)

II FIELD REVISIONS

6. Special Precautions

- a. Before applying the paint, each lead should be carefully checked with a 24 volt source to assure that the correct color is used in each case.
- b. After assembly, the racks should be checked in the usual manner for both manual and electrical operation to assure proper reassembly.

F. REPLACEMENT OF DEFECTIVE ARMING WIRE RETAINERS*

(O.T.I. VII-4, as applicable to MK 51) Issued 4/19/44)
(THIS PROCEDURE IS CONVENIENTLY CARRIED OUT SIMULTANEOUSLY WITH THAT OF SECTION G.)

1. Purpose

This Bureau has received reports of electrical arming failures of the Bomb Racks Mark 50 and Mark 51 types caused by the use of nose and tail arming wire retainers, which are not fabricated in accordance with the applicable Bureau of Ordnance Drawing (328766-1). Therefore, the purpose of this O.T.I. is to provide:

- a. Information concerning the defects in the arming wire retainers.
- b. Instructions for testing the bomb racks for defective arming wire retainers.
- c. Instructions for replacing defective arming wire retainers.

2. Description

- a. Sheet 29 shows at the right the nose and tail arming wire retainer drawn to twice normal size, and dimensioned in accordance with Bu.Ord. drawing 328766-1. The retainer outline is also shown correctly in normal size at the upper left. The incorrect shape is shown in normal size at the lower left. A typical improperly formed retainer has a rounded surface at the point of contact with the arming solenoid plunger rather than a flat surface, forming a sharp corner with the lobe of the retainer.

- b. Analysis of the reported bomb arming failures shows that when the bomb racks are electrically "armed", that the rounded contact surface permits the retainer to rotate, causing the arming solenoid plunger upward sufficiently to permit "safe" drops.

*The field testing specified here should be carried out on Mod 6 and 7 racks. All Mod 8 and 9 racks are so tested at the factory, and meet the requirements.

RESTRICTED

(IIF)

II FIELD REVISIONS

- c. In order to ensure that "safe" drops will not occur when electrically "armed", all activities concerned with the operation or maintenance of the subject bomb racks are requested to test those racks now in service, or received in the future, for proper electrical arming characteristics as given under "Maintenance" in this NavOrd OTI. Any racks found to have defective arming wire retainers should be replaced immediately if satisfactory replacements are available. The defective racks should be suitably tagged and turned into supply for shipment to the nearest overhaul activity for corrections. Where replacement racks are not available, and if manual arming provisions are incorporated in the airplane, the defective bomb racks should be used with manual arming only until replaced or until properly fabricated arming wire retainers can be obtained and installed. Until replacement retainers are available, activities are authorized to manufacture replacement retainers locally, if necessary, in accordance with Bureau of Ordnance drawing number 328766-1 (See sheet 28)
- d. Replacement arming wire retainers having the correct contour are being procured, and will be distributed to all major supply points as rapidly as possible. They may be obtained through the nearest source of supply, under Stock No. 3-R-543.

3. Installation

- a. The following procedure is recommended for replacing the defective arming wire retainers:-

Bomb Racks, Mark 51 type

- (1) Test the bomb rack as outlined under (1), (2), (3), (4) and (5) in "Maintenance" below. If electrical arming is unsatisfactory install replacement arming wire retainers as follows:
- (2) to (7) Remove the arming unit from rack as in steps (1) thru (6), section C, para. 4a.
- (8) Remove slip pin (BuOrd. Dr. No. 328766-8) and withdraw arming plunger (BuOrd. Dr. No. 328766-5) from arming assembly channel (BuOrd. Dr. No. 328765-1).
- (9) Remove the two (2) arming solenoids from the channel by pushing out the two (2) slip pins (BuOrd. Dr. No. 328785-40) that hold each solenoid. If possible, avoid breaking the ground connection soldered to the channel.

RESTRICTED

II FIELD REVISIONS

(IIF)

(10) Remove the subassembly consisting of the guard (BuOrd. Dr. No. 328766-3), the two (2) arming wire retainers (BuOrd Dr. No. 328766-1), the two (2) springs (BuOrd Dr. No. 328766-2) and the four (4) spacers (BuOrd Dr. No. 328766-4) from the channel by removing the two (2) slip pins BuOrd. Dr. No. 328785-43).

(11) Remove the arming wire retainers, the spring and the spacers from the guard.

(11a) Bend the straight end of the guard to the radius shown. This will prevent chafing of the tail solenoid lead wire. Ref. BuOrd Dr. 328766 Chg. D.

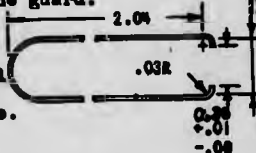

(12) Remove the springs from the defective arming wire retainers, and reassemble them to the replacement arming wire retainers.

(13) Reassemble the replacement retainers, the springs, and the spacers in the guard.

(14) Insert the subassembly (removed in step 10) in the channel assembly and replace the two (2) pins securing it.

(15) Replace in the channel, the arming plunger and slip pin which were removed in step (8).

(16) Insert the two (2) continuous duty solenoids in the channel and replace the slip pins removed in step (9).

(17) Check the grounding wire for good bonding on the channel, resolder if necessary.

(18) to (23) Reassemble arming unit into rack as in steps (13) thru (17a) in section C, para. 4e.

4. Operation
5. Maintenance

a. The following procedure is recommended for testing the arming wire retainers of the subject bomb racks. The retainers at both the nose and tail arming position of each bomb rack should be tested.

(1) Locate the loop or plate of an arming wire in one of the arming wire retainers of the bomb rack.

RESTRICTED

II FIELD REVISIONS

(IIF)

- (2) Electrically energize the solenoid for the arming wire retainer being tested.
- (3) Apply a load of approximately 25 pounds, vertically downward to the arming wire.
- (4) If the arming wire is not released in step (3), apply the 25 pound load at an angle of about 45 degrees to the underside of the bomb rack and in the direction of the stop for the toe end of the arming wire retainer.
- (5) If the arming wire is released in either step (3) or step (4) the arming wire retainer is unsatisfactory for electrical arming and should be replaced in accordance with the instructions given above.

6. Special Precautions

- a. Precautions of paragraph b, c and d of section C, para. 7 should be observed. (Sheet 19)
- b. Upon completion of the installation, the racks should be tested both manually and electrically for proper operation prior to use.

RESTRICTED

II FIELD REVISIONS

(IIG)

G. SUGGESTED METHOD OF GROUND CHECKING WHILE LOADED*(O.T.I. V13-44, issued 5/30/44.

1. References

- a. NavOrd OCL V3-44, "Reported Malfunctions of Bomb Racks Mark 50 and Mark 51 Type - Temporary Corrective Measures for." (Section IIA in this book)
- b. NavOrd OTI V27-43 "Bomb Rack Mark 51 type - Procedure for drilling hole for insertion of Safety Pin." (Section IIA in this book.)

2. Purpose

Reference (a) emphasizes the necessity of making frequent ground checks and flight tests of the subject bomb rack installations. The purpose of this NavOrd OTI is to acquaint the service with, and authorize use of, a method devised by Commander Air Force, Atlantic Fleet to facilitate ground checks of the subject racks while loaded.

3. Description

Manual and electrical release of subject bomb racks may be readily ground checked when loaded by inserting a special lock and relatch pin through holes properly located in the sides of the rack. Details of the pin, which has a flat surface on one side, are shown on sheet 33. The pin is inserted with the flat side up, and serves to stop downward movement of the release pawl before the hooks have opened. By rotating the pin, the rack may be readily relatched.

Activities desiring to use the ground check method described above are to construct the quantity of lock and relatch pins as required. Such activities are also to drill the necessary holes in the rack side plates, using the procedure described in paragraph 4.

4. Installation

- a. Manufacture a drilling template in accordance with the details as shown on sheet 33 (One drilling template should be sufficient to drill all racks being modified.)
- b. Clamp drilling template against side plate of bomb rack, using C-clamp or vice (position template as shown on sheet 34.
- c. Drill a 1/4" pilot hole through adjacent side plate of rack.
- d. Shift template to opposite side of rack and repeat

*Mod B & 9 Racks have this feature when delivered from factory.

RESTRICTED

FIELD REVISIONS
INSTALLATION, GROUND-CHECKING PIN

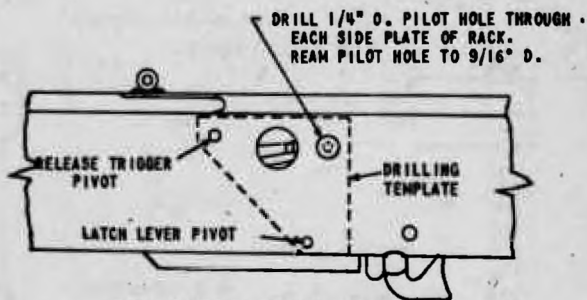

POSITIONING OF DRILLING TEMPLATE
ON MK 51 BOMB RACK

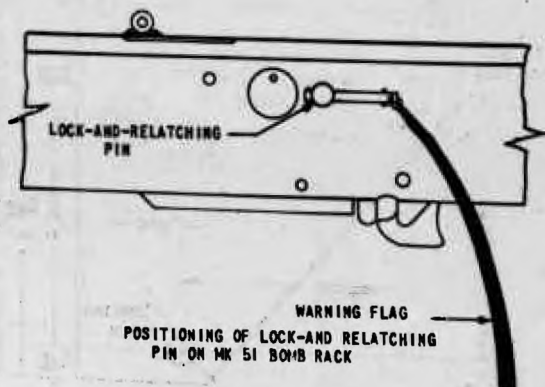

POSITIONING OF LOCK-AND RELATCHING
PIN ON MK 51 BOMB RACK

FIGURE 2

RESTRICTED

II FIELD REVISIONS

(IIG)

- e. Ream pilot holes to 9/16" diameter from each side of rack. Care must be taken to prevent damage to internal linkage of rack during the drilling and reaming operation.
- f. Carefully clean all metal cuttings from the rack mechanism in the following manner:
 - (1) Remove the lower aft hoist bracket bolt and the spacer.
 - (2) Remove the release lever pivot pin lock ring and the release lever pivot pin.
 - (3) Now lower the afterend of the release assembly unit from between the side plates of the bomb rack sufficiently to allow access for cleaning.
 - (4) Remove all metal cuttings from between the bomb rack side plates, and make sure that no metal cuttings are left in the release assembly.
 - (5) Reposition the release assembly and secure in place with the parts removed in steps (1) and (2) above.
- g. Manufacture lock and re latch pins in accordance with the details as shown on sheet 33. A warning flag should be attached to each pin handle so as to be easily seen from below the rack and the bomb.

5. Operation

- a. Insert a lock and re latch pin, flat side up, into each loaded bomb rack on the airplanes being checked.
- b. Operate the manual release controls from the bomber's compartment.
- c. Check action of each rack. Release pawl should be unlatched and bearing on lock pin.
- d. Re latch rack by rotating lock and re latch pin. A definite click should be heard.
- e. Operate the electrical release controls from the bomber's compartment and repeat steps c and d.
- f. Repeat steps b, c, d, and e several times. Replace any malfunctioning racks.
- g. Remove all lock and re latch pins. Caution must be taken to ensure that the bomb rack is re latched before removing the pin. These new pins may be

RESTRICTED

II FIELD REVISIONS

(IIR)

used to render the subject racks safe when loaded in lieu of the safety pins specified in reference (5).

6. Maintenance

7. Special Precautions

- a. When lowering the release assembly unit from between the side plates of the bomb rack, as discussed in paragraph 4F(3), care must be taken not to strain the electrical leads to the release solenoid and transfer switch. When all "sleek" has been removed from these electrical leads, do not attempt to force the release assembly lower.
- b. Before the airplane takes off on a mission, recheck all racks for removal of the lock and relatch pins, as otherwise the racks will not release.

H. MAINTENANCE OF BOMB RACKS MARK 50 AND 51 TYPES

(O.S. 156-44, issued 6/19/44, as applicable to MK 51)

1. References

- a. NavOrd OCL V3-44 or II-K in this book, "Reported Malfunctions etc."
- b. NavOrd OTI V39-43 or II-D in this book, "Cold weather operation, etc."
- c. O.S. 1374, "Specifications for Chromate Treatment of Zinc (or Cadmium) Surfaces."

2. Purpose

- a. The purpose of this NavOrd OTI V is to provide the Service with revised maintenance instructions for the subject bomb racks in accordance with reference (a). The instructions contained herein supersede all previously issued maintenance instructions for cleaning and preservation of the Bomb Racks, Mark 50 and 51 Types.

3. Description

- a. The following steps are described in this NavOrd OTI:
 1. Removal of tectyl.
 2. Removal of corrosion.
 3. Replating of zinc or cadmium plated parts.
 4. Chromate treatment of cadmium or zinc plated parts.
 5. Treatment of certain parts with air-dry, vinyl resin type Iscuar, O.S. 1544.
 6. Application of Orsac, O.S. 1350 to certain parts.

RESTRICTED

II FIELD REVISIONS

(IIR)

- b. After the initial removal of Tectyl and application of protective materials, which should be carried out as soon as practicable, the bomb racks should be maintained by subsequent cleaning, reapplication of protective materials, and replacement of parts as required for proper operation. Deviations from these instructions to suit local operating conditions are authorized. Necessary maintenance materials should be requisitioned from the nearest source of supply. Applicable stock numbers are given in paragraph 6.

4. Installation

5. Operation

6. Maintenance

a. Removal of Tectyl.

- (1) In order to effectively remove the Tectyl the bomb racks must first be completely disassembled, excepting the hook-link assembly of the Bomb Racks, Mark 51 Type, which should be removed from the sideplates, but not disassembled unless necessary for replating or for replacement of parts. It is recommended that one of each type of the subject bomb racks be broken down into its major subassemblies and used as a guide for personnel engaged in the assembly and disassembly work.
- (2) The Tectyl should be removed from all parts with cleaning solvent ("Stoddard Solvent" or "Vareol") in accordance with the following (Chlorinated Solvents should not be used as they tend to promote corrosion):
 - (a) Release Solenoids.--Remove the rubber cap and the plunger. Wipe the plunger, plunger cavity, the outer surfaces of the solenoid housing and the electrical conductor free of Tectyl with a clean cloth moistened in the solvent. Dry all parts thoroughly to avoid damage to the electrical conductor and the solenoid windings by the solvent. Reassemble, making certain that the vent hole in the rubber cap is located downward (in line with the lead wire outlet) to prevent entrance of water into the solenoid cavity. If the rubber cap is damaged, install a new one. See reference (b).

RESTRICTED

II FIELD REVISIONS

(IIR)

- (b) Arming Solenoids. - Replace all arming solenoids which have been dipped in Tectyl with Tectyl-free solenoids. Tectyl-free solenoids are available under the stock number assigned to continuous duty arming solenoids. These solenoids are manufactured by Sempel Time Control, Inc. and may be identified by the letter "S.T.C." printed on the top and the letter "C" stamped on the bottom of the solenoid housing. Note - These solenoids are not satisfactory for continuous duty. See OCL V3-44, OTI V33-43 and NavOrd OTI W4-44. Arming solenoids suitable for continuous duty will be distributed as soon as they are available.
- (c) Transfer and Pilot Light Switches. - Wipe all Tectyl from the exterior surfaces of the pilot light switches and transfer switches with a cloth moistened in the solvent and dry thoroughly. Test each switch for proper operation by means of a test circuit. Any switches found to be inoperable due to Tectyl on the contact surfaces or from other causes, should be replaced.
- (d) Electrical Lead Wires and Plastic Parts of Electrical Connector Receptacle. - Remove the Tectyl from these parts by wiping with a cloth moistened in the solvent. Dry thoroughly with a clean dry cloth to prevent damage to parts by the solvent.
- (e) Remaining parts of Bomb Racks. - Remove the Tectyl from all remaining parts of the subject bomb racks by successive dips in the solvent. The parts should be dipped in three separate baths and should be agitated while in the solvent. Allow the parts to drain thoroughly between dips. The solvent used in the final dip should be changed frequently to avoid contamination.
- b. Removal of Corrosion
- (1) All parts should be cleaned free of corrosion products. Parts which are corroded should be carefully inspected and should be replaced if any weakness or appreciable dimensional changes are evident.
- c. Zinc or Cadmium Plating.

RESTRICTED

(III)

II FIELD REVISIONS

- (1) If facilities are available, all cadmium or zinc plated parts with the exception of the arming and release solenoid assemblies, should be re-plated if inspection shows the plating to be in a deteriorated condition.

d. Chromate Treatment.

- (1) Where facilities exist, all zinc or cadmium plated parts with the exception of the arming and release solenoid assemblies, should be given a chromate treatment in accordance with reference (c) except in cases where parts have already been given this treatment by the manufacturer and the surfaces are in good condition. Chromate treated parts may be identified by a distinctive golden-brown color.

e. Lacquer.

- (1) Lacquer, O.S. 1544 which has a blue color, should be applied to the parts of the subject bomb racks in accordance with the figure on sheet 40. The lacquer as received is suitable for application. Thinner for lacquer O.S. 1544 should be added as necessary to maintain the lacquer at approximately the same viscosity (40-50 seconds, Zahn cup No. 1 or 21-27 seconds Ford Cup No. 3). Certain of the parts should be sprayed as indicated, the remaining parts may be sprayed or dipped as preferred. Dipped parts should be given two coatings. The parts should be dried thoroughly between coatings, and before assembly (12 hours at room temperature -30 minutes at 160°F). Parts to be sprayed should be covered with an even continuous film having approximately the same thickness (as determined by color comparison) as that obtained in the application of two coats by dipping. All parts should be thoroughly clean and dry before lacquering in order to obtain satisfactory adhesion.
- (2) Prior to reapplication, old lacquer should be removed from the parts with the lacquer thinner.

f. Grease.

- (1) Each time the solenoids are removed from the bomb racks, Grease O.S. 1350 should be applied to the plunger pins of the nose and

RESTRICTED

(IIR)

II FIELD REVISIONS

tail arming solenoids of the subject bomb racks as a protection against corrosion. Extend the plunger pin its maximum distance (about 11/16 in.) and apply a very thin film of the grease to the entire extended length. Only a thin film of grease is required to afford adequate corrosion protection and a heavy coating can render the solenoids inoperative at low temperatures.

- (2) It is recommended that Grease, O.S. 1350 be applied over the threaded sections of the bomb steadying forks of the Bomb Racks Mark 50 Type if the racks are being used under conditions which produce corrosion of these parts.

g. List of Materials.

<u>Item</u>	<u>Stock No.</u>
1. Cleaning Solvent (Stoddard Solvent or Varsol).	R-51-C-1326-67 (5 gal. container) R-51-C-1326-75 (55 gal. drum)
2. Lacquer, Air Dry Vinyl Resin Type, Blue, O.S. 1544	52-L-1132 (1 qt. container). 52-L-1133 (1 gal. container). 52-L-1134 (5 gal. container). Note: 1 gal. is sufficient to treat approximately 60 bomb racks.
3. Thinner, for lacquer, Air Dry, Vinyl Resin Type, Blue, O.S. 1544	52-T-604 (1 pint container). 52-T-605 (1 qt. container). 52-T-606 (1 gal. container). Note: One part of thinner will ordinarily be required for every 6 parts of lacquer.
4. Grease O.S. 1350	14-G-705 (Collapseible Tubes) Note: One tube is sufficient to treat approximately 300 arming solenoids or 35 steadying forks.

Note: Item 1 is available in Aeronautical Stores. Initial distribution of items 2, 3, and 4 will be made to all major supply points by the Bureau of Ordnance. Replenishment requests for items 2, 3, and 4 should be made through the regular Aviation Ordnance distribution system.

- h. List of Spare Parts for Bomb Rack Mark 50 end Mods.
(Not applicable to this book)

RESTRICTED

II FIELD REVISIONS

(IIR)

1. List of Spare Parts for Bomb Racks Mark 51 Mod. 6 and 7.

Item No.	Stock Number	Name of Item	Drawing Number
1	3-B-2599-300	Bracket, Hoist	328773-4
2	3-B-3196-200	Bushing, Cable	328773-28
3	3-C-114-20	Cable, Arming	328766-7
4	3-C-117-200	Cable, Release Assem.	328774-8
5	3-C-665	Cap, Solenoid Release	328772-7
6	3-C-1308-500	Channel, Arming, Assem.	328765-1
7	3-C-1308-550	Channel, Release Assem.	328770-2
8	3-C-2184	Cover, Slot	328773-27
9	3-D-630	Diac. Cover	328773-9
10	3-G-1110	Guard, Retainer	328776-3
11	3-H-1132	Hook, Release	328763-3
12	3-I-360	Insulator, Receptacle, Lower	328773-17
13	3-I-365	Insulator, Receptacle, Upper	328773-16
14	3-L-356	Lever, Assembly	328771-1
15	3-L-1175-600	Link, Connecting Hook	328763-7
16	3-L-1176-65	Link, Operating Pawl	328763-7
17	3-P-344-21	Pawl, Assembly	328763-4
18	3-P-649-250	Pin, Plunger	328766-8
19	3-P-649-400	Pin, Retainer	328785-43
20	3-P-650	Pin, Solenoid Release	328785-41
21	3-P-1614-25	Plate, Bracket Hoisting	328773-31
22	3-P-1840	Plug, Inspection (1/4")	328773-3
23	3-P-1841	Plug, Inspection (11/32")	328773-32
24	3-P-2068-12	Plunger, Retainer	328766-5
25	3-R-458-200	Receptacle, Assembly	328773-12
26	3-R-543	Retainer, Arming	328766-1
27	3-R-747-100	Ring, Lock Hook	328785-22
28	3-R-747-150	Ring, Lock Lever	328785-20
29	3-R-747-300	Ring, Lock Trigger	328785-21
30	3-R-1264-250	Rivet, Hook	328763-8
31	3-R-1265-200	Rivet, Pawl	328763-9
32	3-S-1086	Screw, Pawl Latching	328773-2
33	3-S-2762	Shield, Wire	328773-8
34	3-S-3475	Solenoid Arming Nose Assembly (24V) (Includes housing)	389251-15
35	3-S-3478	Solenoid, Arming Tail Assembly	389251-16
36	3-S-3480	Solenoid, Release Assembly, (24 V)	328772-2
37	3-S-3621	Spacer, Bracket Hoisting Long	328773-5
38	3-S-3613-50	Spacer, Bracket Hoisting Short	328773-6
39	3-S-3624-50	Spacer, Clamp Cable	328774-4
40	3-S-3624-300	Spacer, Hook Front	328763-11

RESTRICTED

II FIELD REVISIONS

(IIR)

Item No.	Stock Number	Name of Item	Drawing Number
41	3-S-3624-350	Spacer, Hook Repr	328765-10
42	3-S-3629-175	Spacer, Pawl Inner	328774-12
43	3-S-3629-200	Spacer, Pawl Outer	328774-11
44	3-S-4509	Spring, Armature	328771-5
45	3-S-4553	Spring, Cable	328766-6
46	3-S-4563-200	Spring, Micro Switch	328768-6
47	3-S-4566-50	Spring, Release Cable	328774-10
48	3-S-4568-500	Spring, Retainer	328766-2
49	3-S-4575-50	Spring, Trigger Rel.	328774-7
50	3-S-6379-300	Stud, Hook 3/8x1.09	328785-36
51	3-S-6379-400	Stud, Lever Latch 1/4x.036	328785-31
52	3-S-6379-500	Stud, Lever Operat- ing 5/16x1.09	328785-34
53	3-S-6641	Switch, Micro Arming Assembly	328766-9
54	3-S-6643	Switch, Micro Release	328770-5
55	3-S-1226	Trigger, Manual Rel.	328774-6
56	3-W-463-75	Washer, Clamp Cable	328774-3
57	3-W-463-215	Washer, Link Con- necting	328773-1

7. Special Precautions:

- When assembling the release solenoids in the release assembly of the subject bomb racks, care should be taken to adjust the position of the solenoids with the laminated spacer washers in accordance with diagram on sheet 75 or release difficulties will result.
- After the release assemblies have been assembled make certain that the transfer switch trigger on the release lever is adjusted in accordance with the diagram, in order to obtain proper operation of the transfer switch.
- Make certain that the lacquer on the bearing surfaces of all parts is smooth and free from accumulations or runs.
- Substitute greases should not be used on the plungers of the arming solenoids in place of O.S. 1350 grease as tests show that other greases are unsatisfactory at low temperatures.
- After assembly, all racks should be tested as follows for satisfactory operation both manually and electrically. An inspection jig to facilitate testing of the subject bomb racks is now under procurement and will shortly be distributed to all overhaul and maintenance activities.

RESTRICTED

II FIELD REVISIONS

(IIE)

Manual Operation. - Latch the bomb rack and test for satisfactory manual release by actuating the manual release cable. Test for satisfactory manual arming with the manual arming cable in the "safe," "tail armed," and "nose and tail armed" positions.

Electrical Operation. - Latch the bomb rack and test for satisfactory electrical release at 75 percent of rated voltage. The bomb rack should be latched and released four (4) times without failure and the pilot light switch and the transfer switch should operate satisfactorily. Each arming circuit should be energized twice at 75 percent of rated voltage and the appropriate arming wire retainer checked for positive retention of the arming wire when the circuit is energized. Upon assurance that the electrical arming functions satisfactorily when energized, the arming wire retainers should be tested for proper retention with circuit de-energized.

RESTRICTED

II FIELD REVISIONS

(IIJ)

I. BOMB RACK, MARK 51, MODS. 8 and 9
 (OTI V19-44, Issued 7/4/44)

1. References

- a. O.P. 925, "Bomb Rack, Mark 51 Mode. 6 and 7."
- b. NavOrd OCL V3-44, "Reported Malfunctions, etc.—Temporary Corrective Measures For." (IIX in this book)
- c. NavOrd OTI V16-44, "Maintenance of Bomb Racks, Mark 50 and 51 Types." (IIX in this book)
- d. Bureau of Ordnance List of Drawing Sketch Nos:

Bomb Rack, Mark 51 Mod. 8	109454
Bomb Rack, Mark 51 Mod. 9	109455

e. Bureau of Ordnance Drawings:

Outline Drawing No. 438060 - Bomb Rack, Mark 51 Mods. 8 and 9.

f. Federal Standard Stock Nos:

Bomb Rack, Mark 51 Mod. 8 (12 volt-left)	3-R-177-110
Bomb Rack, Mark 51 Mod. 8 (12 volt-right)	3-R-177-115
Bomb Rack, Mark 51 Mod. 8 (12 volt-center)	3-R-177-100
Bomb Rack, Mark 51 Mod. 9 (24 volt-left)	3-R-177-155
Bomb Rack, Mark 51 Mod. 9 (24 volt-right)	3-R-177-160
Bomb Rack, Mark 51 Mod. 9 (24 volt-center)	3-R-177-150

2. Purpose

This OTI is issued for the purpose of disseminating information to the service on the Bomb Racks, Mark 51 Mods. 8 and 9. This NavOrd OTI supplements reference (a).

3. Description

- a. It is the intention of this Bureau to provide Bomb Racks, Mark 51 Mods. 8 and 9 in lieu of the present Bomb Racks, Mark 51 Mods. 6 and 7 on new aircraft installations only, since a further and more complete modification (to be known as Bomb Rack, Mark 51 Mods. 10 and 11) will be available for general Fleet replacement about October 15. Bomb Racks, Mark 51 Mods. 8 and 9 include only those improvements which can be immediately incorporated in production and are intended to only partially correct the difficulties discussed in reference (b). In order that Fleet units may take immediate advantage of these improvements NavOrd OTI's and OMI's have been issued for field modification of Bomb Racks, Mark 51 Mode. 6 and 7. Information regarding the complete replacement of all Bomb Racks, Mark 51 Mods. 6, 7, 8, and 9 by Bomb Racks Mark 51 Mods. 10 and 11 will be disseminated in a future NavOrd OTI.

RESTRICTED

II FIELD REVISIONS

(IIJ)

b. The Bomb Racks, Mark 51 Mods. 8 and 9 incorporate the following new features:

- (1) The arming solenoids will be in accordance with BuOrd Dwg. No. 389251 (Rev.F). These arming solenoids are suitable for continuous duty operation. (See VIIB2 in this book)
- (2) The arming wire retainers will be in accordance with BuOrd. Dwg. No. 328766-1 thereby correcting electrical arming failures due to improper contour of the arming wire retainers. (IIF in this book)
- (3) The bomb racks will incorporate the low temperature cap, (BuOrd Dwg. No. 328772-7 Rev. B) resulting in improved performance of the release solenoid at low temperature. (IID in this book)
- (4) The bomb racks will be Tectyl free and will be processed in accordance with reference (c) (IIE in this book)
- (5) The pawl latching screw will be in accordance with BuOrd. Dwg. No. 328773-2 (Rev.D) to facilitate the latching operation (IIL in this book)
- (6) The sideplates of the bomb rack incorporate a hole for a ground checking device in accordance with BuOrd Dwg. No. 328760 (Rev. C). Use of this ground checking device permits checking of the electrical and manual release of the bomb rack while loaded. (IIG in this book)
- (7) The sideplates of the bomb rack will also incorporate a hole for a taper locking pin in accordance with BuOrd Dwg. No. 328760 (Rev.B). Use of the taper locking pin renders the bomb rack safe against accidental release when the airplane is not in flight. (IIA in this book)

4. Installation

The installation of the Bomb Racks, Mark 51 Mods. 8 and 9 is identical with that of the Bomb Racks, Mark 51 Mods. 6 and 7.

5. Operation

6. Maintenance

The Bomb Racks, Mark 51 Mods. 8 and 9 should be maintained in accordance with reference (a) in lieu of reference (a).

7. Special Precautions

The safety precautions for the Bomb Racks, Mark 51 Mods. 6 and 7 are applicable for the Bomb Racks, Mark 51 Mods. 8 & 9.

RESTRICTED

II FIELD REVISIONS

(I.R.)

K. REPORTED MALFUNCTIONS & TEMPORARY CORRECTIVE MEASURES
(OCL V3-44 as applicable to MK 51) (issued 5/15/44)**1. General Program**

Frequent reports of malfunctioning of Bomb Racks, Mark 50 and Mark 51 Types are being received from Fleet operating activities. These reports show the need for improved bomb racks having more reliable operating characteristics. The Bureau of Ordnance, therefore, is now designing, under high priority, new bomb racks to replace those in service. In addition, as an interim measure, individual malfunctioning components and assemblies of the subject bomb racks are being re-designed. Replacement parts for use in the present bomb racks will be procured and distributed as promptly as possible. Detailed instructions for the installation of these replacement parts will be disseminated to all activities concerned when the parts are available.

2. Purpose of this section

It is pointed out further that even the interim measure of providing replacement parts for the present bomb racks is time consuming, and that until corrective parts or replacement bomb racks can be made available to the Fleet, it is necessary that every effort be made to obtain the maximum effectiveness from the present bomb racks. To this end, analyses of the various malfunctions which have been reported, and recommended temporary remedial measures to be taken in each instance, are summarized in subsequent paragraphs.

3. Electrical Arming**a. Malfunctions**

- (1) Continuous duty arming solenoids (Stock No. 3-S-3386-50, 24 Volt and 3-S-3386-25, 12 Volt), identifiable by the letter "C" stamped on the underside of the base, were procured as replacements for the original non-continuous duty arming solenoids in Bomb Racks, Mark 50 and Mark 51 Types (Reference OTI V33-43). However, it has been found that after continuous arming the replacement solenoids for a short period (as little as one hour) the solenoid plungers may stick in the armed position, failing to retract when the solenoids are de-energized.
- (2) In some instances, the high temperatures sustained by the solenoids during continuous duty operation have resulted in melting of the internal soldered ground connection of the solenoid coil, causing complete electrical arming

RESTRICTED

• II FIELD REVISIONS

(IIC)

failure. Also the high temperatures encountered during continuous operation have caused the soldered connection of the exterior bonding wire to melt. The exterior bonding wire is required to provide a positive ground connection for the replacement solenoids in accordance with OTI V4-44 or IIC in this book.

- (3) Arming solenoids which have been dipped in Tectyl may not actuate instantly when energized, due to deposits of Tectyl in the solenoid cavity. An average "on" time of approximately seventy seconds has been found necessary to allow the solenoid to warm up sufficiently to soften the Tectyl and free the solenoid plunger.
- (4) Electrical arming failures have occurred due to the use of nose and tail arming wire retainers which are not fabricated in accordance with the applicable Bureau of Ordnance Drawing (BuOrd Dwg. No. 328766-1). The defective arming wire retainers have a rounded surface at the point of contact with the plunger of the arming solenoid, rather than a flat surface forming a sharp corner with the lobe of the retainer. The rounded contact surface may permit the retainer to rotate even when the solenoid is energized, causing the arming solenoid plunger upward sufficiently to permit "safe" drops.

b. Suggested Corrective Action

- (1) In cases where continuous duty arming is required, use bomb arming controls in accordance with NavOrd OTI V29-43 (IIB in this book) and OP 1084.
- (2) In cases where continuous duty arming is not essential, replace all Tectyl-dipped solenoids with Tectyl-free solenoids. Tectyl-free solenoids are available under the stock numbers assigned to continuous duty solenoids. These solenoids are manufactured by Sappeel Time Control, Inc., and may be identified by the letters "S.T.C." printed on the top, and the letter "C" stamped on the bottom, of the solenoid housing. Instructions for replacing the solenoids are given in IIC of this book. When using these arming solenoids, however, the rack should be armed electrically shortly before actual armed release and returned to "safe" soon thereafter.

RESTRICTED

II FIELD REVISIONS

(IIK)

- (3) Both arming wire retainers of all of the subject bomb racks now in service or received in the future should be tested according to the instructions of section IIF, sheet 30.
- (4) Thorough tests of the arming solenoids should be made prior to each operation involving armed releases as follows:
 - (a) The solenoids should be energized and the arming wire retainers checked for the positive retention of the arming wire swivel loops or plates.
 - (b) Upon assurance that the solenoids function properly when "armed," they should be de-energized and a test made for proper rotation of the arming wire retainers, thereby assuring "safe" drops when desired.

. Pawl Latching Screws, Bomb Rack, Mark 51 Type**a. Malfunctions**

- (1) The improper assembly of pawl latching screws (BuOrd Dwg. No. 328773-2) has caused failure of Bomb Racks, Mark 51 Type to release when actuated either electrically or manually. If the inspection hole cover disc or any of the washers through which the pawl latching screw extends are lost or broken, the threaded portion of the screw, when tightened, will protrude into the channel of the release pawl and interfere with the operation of the release lever assembly (BuOrd Dwg. No. 328771-1).
- (2) Further, because of the small gripping surfaces of the original latching screws supplied with the rack, many activities have fabricated substitute screws in order to facilitate the latching operation. Release failures caused by using substitute screws which have a threaded portion of greater length than the original screw have been reported. Even if the required cover disc and washers are used with these replacement screws, the threaded portion can interfere with the release mechanism of the rack and cause release failure.

b. Suggested Corrective Action

- (1) If the original type latching screws are used make certain that sufficient spacers are in place in order to prevent interference with the release mechanism. If sufficient spacers are

RESTRICTED

II FIELD REVISIONS

(IIK)

not used, make certain that the threaded portions of the screws are sufficiently short so that they cannot extend through the link assembly (BuOrd Dwg. No. 323763-7).

- (2) The design of an improved pawl latching screw has been completed and replacement screws for the bomb racks now in service will be procured and distributed in the near future. A NavOrd OMI (V12-44) now under preparation will include necessary information for obtaining the revised screws when available. Sufficient details for local manufacture, where desired, are shown therein.

The cover discs should not be used with the revised screws. The new latching screws have adequate gripping surface and have non-removable, "crimped on" lock washers.

See II-L in this book for OMI V-12-44.

5. Steadying Forks, Bomb Racks, Mark 50 Type
(Not applicable to MK 51)

6. Release Solenoid, Bomb Racks, Mark 50 and 51 Types

e. Malfunctions

- (1) Deposits of Tectyl in the release solenoid cavity can bind the solenoid plunger sufficiently to prevent electrical releasing operation of the Bomb Racks, Mark 50 and 51 Types. This condition is aggravated at low temperatures.
- (2) Further, manual release failure can occur in the Bomb Racks, Mark 51 Type due to the binding of the release solenoid plungers by Tectyl. Because of the Tectyl in the solenoid cavity, the plunger may not be depressed upon actuation of the manual release. The head of the plunger will then obstruct the downward movement of the release pawl, causing a bomb "hang up."

b. Suggested Corrective Action

- (1) If the release solenoids are subject to the difficulties described above, the solenoids must be disassembled and any Tectyl deposits on the plunger or in the plunger cavity removed. Instructions for removing the solenoid and the solenoid cap are given in NavOrd OMI V39-43, (IID in this book) The cleaning solvent used should be applied sparingly and the solenoid dried thoroughly to avoid damage to the insulating material and the rubber cap. Solenoid rubber caps are available to replace any damaged in the disassembly of the releasing solenoid.

RESTRICTED

(IIR)

II FIELD REVISIONS

7. Protection against corrosion, Bomb Racks, Mark 50 and 51 Types

a. Malfunctions

- (1) Most of the subject bomb racks in present service were dipped in Tectyl 506 by the manufacturer for protection against corrosion (none beyond MK 51 Mods 6 & 7). In addition to the difficulties due to deposits of Tectyl in the arming and release solenoids as discussed under paragraphs 3 and 6 above, it has been found that Tectyl can sufficiently bind the various linkages in the bomb racks to cause release failures or excessive release lags. This difficulty is particularly prevalent at low temperatures. Further, dust, dirt, and encrusted salt readily adhere to the Tectyl. The accumulation of such foreign material in the mechanism of the bomb racks adversely affects their operation.

b. Suggested Corrective Action

- (1) If the above difficulties are encountered, it is recommended that activities remove the Tectyl from the bomb racks. Because of the type of construction, it is necessary to disassemble the racks to clean them properly. Further, the promiscuous use of such solvents as kerosene or carbon tetrachloride is harmful to the electrical units (solenoids, switches, and lead wires). The plastic parts of the electrical connector receptacle are especially susceptible to deterioration upon contact with carbon tetrachloride. However, if used sparingly, these solvents are considered the most effective means for removing Tectyl from the rack linkages and remaining parts. After application of the solvent, all parts should be thoroughly dried without delay. Tectyl-dipped arming solenoids should be replaced as per paragraph 3b(2).
- (2) The use of Tectyl on new production bomb racks has been discontinued. It is recommended that activities disregard the instructions given in OP925 which call for treating the racks with Tectyl, and that the racks be used without protective coating until preservative measures are issued by this Bureau. It is pointed out that untreated racks may corrode rapidly in some locations, and careful inspections and checks should be made at frequent intervals for evidence of any possible malfunction due to corrosion.

RESTRICTED

II FIELD REVISIONS

(IIX)

- (3) A RevOrd OTI-V (V16-44, or IIX herein) concerning protection of the subject bomb racks against corrosion will be issued shortly and will include instructions for coating certain of the parts with an air-dry, vinyl resin type lacquer. Properly applied, this lacquer does not interfere with the operation of the bomb racks and gives excellent protection to the treated parts. Until more complete information on the protection of bomb racks against corrosion can be procured, it is recommended that the plungers of the arming solenoids be treated with a very thin film of O.S. 1350 grease (Stock No. 14-8-720) whenever the solenoids are removed from the racks. Tests show that a thin film of this grease will maintain the solenoid plungers free from corrosion for relatively long periods, and that solenoids so treated are operable at temperatures as low as -70°F . The solenoid plunger should be extended its maximum distance (about 11/16 in.) and the grease thinly applied over the entire extended length. Substitute grease should not be used, as unsatisfactory results have been obtained in tests using other greases. If O.S. 1350 is not available, the solenoid plungers should be left free of any coating. The release solenoid plungers should not be oiled, as the rubber cup gives adequate protection and the addition of any protective material may result in release failures.

8. Manual Operation

a. Malfunctions

- (1) Difficulties with manual operation of the Bomb Racks, under conditions of severe airplane wing flexing have been reported and are attributed to the short travel distances of the arming and release cables of the bomb racks.

b. Suggested Corrective Action

- (1) The tension of the manual control cables in the airplane should be carefully adjusted and maintained to insure that the manual release and arming mechanisms of the bomb racks can be properly actuated by movement of the control levers. The travel distances of the arming and release cables for the Bomb Rack, Mark 51 type are given on sheet 71.

RESTRICTED

(IIK)

II FIELD REVISIONS

9. This Bureau wishes to emphasize the necessity of making frequent ground checks and flight tests of the subject bomb rack installations. To facilitate making ground checks of the Bomb Racks, Mark 51 Type, a method for testing electrical and manual releases of the racks without necessity for unloading bombs from the racks has been devised. The test method requires drilling a hole through the rack sideplates and manufacturing a simple camming tool. Complete information which will enable activities to make use of this method of testing the bomb racks will be included in an OTI-V to be issued shortly. (OTI VI3-44 or IIG in this book)

RESTRICTED

II FIELD REVISIONS

(III)

I. PAWL LATCHING SCREWS, REPLACEMENT(OMI V-12-44, issued 5/12/44)

1. References

- a. This is the first NavOrd OMI-V which has been ordered for the subject equipment.
- b. BuOrd Dr. No. 328773-2, Rev. D, Pawl Latching Screw
- c. BuOrd Dr. No. 328763, Rev. D, Hook and Link Assembly and Details.
- d. BuOrd Dr. No. 328758, Rev. D, Outline - Bomb Rack AN-Mark 51 Mods. 6 and 7.

2. Purpose - Urgency

- a. This Bureau has received reports of failure of Bomb Racks Mark 51 Mods 6 and 7 to release when actuated either electrically or manually, due to interference with the release lever assembly by the pawl latching screws. The reports indicate that the failures have been due to one of the following causes:
 - (1) When the inspection hole cover disc or any of the washers through which the pawl latching screw extends are lost or broken, the threaded portion of the screw will protrude into the channel of the release pawl and interfere with the operation of the release lever assembly (BuOrd Dr. No. 328771-1)
 - (2) Because of the small gripping surface of the original latching screws supplied with the rack, many activities have fabricated substitute screws in order to facilitate the latching operation. When these substitute screws have a longer threaded portion than the original screws, interference with the release lever assembly will cause release failure even though the required cover discs and washers are used.
- b. The purpose of this NavOrd OMI-V is to provide instructions for the installation of new type pawl latching screws (BuOrd Dr. No. 328773-2, Rev. D) so as to prevent recurrence of this malfunction.
- c. It is requested that the pawl latching screws originally furnished with the subject bomb racks and those substitute pawl latching screws having a longer threaded section than shown on sheet 56, be replaced by the new type pawl latching screws as soon as possible.

RESTRICTED

II FIELD REVISIONS

(IIL)

3. Items to which Applicable

- a. All Bomb Racks Mark 51 Mods. 6 and 7 in service and in supply.

4. Source and Supply of Material

- a. All activities effected by this modification are requested to draw the revised pawl latching screws (Screw, Pawl Latching, Revised, Stock No. 3-S-1086, BuOrd Dr. No. 328773-2, Rev. D) from their nearest supply source. These screws are furnished with lock washers (AN 935-10, BuOrd Dr. No. 329209-91).
- b. Where desirable, local manufacture of the revised pawl latching screws in accordance with the sketch is allowed.

5. By Whom Performed

- a. This replacement program will be carried out by:
 - (1) Personnel of operating activities charged with the maintenance and operation of the subject bomb racks.
 - (2) Where possible, by personnel of supply activities stocking the subject bomb racks.

6. Instructions for Accomplishing Work

- a. Remove the two (2) pawl latching screws (BuOrd Dr. No. 328773-2), the two (2) lock washers (BuOrd Dr. No. 329209-11), the two (2) cover discs (BuOrd Dr. No. 328773-9) and, where applicable, the two (2) disc spacers (BuOrd Dr. No. 328773-10) from the hook link assembly of the bomb rack.
- b. Install the two (2) revised pawl latching screws (BuOrd Dr. No. 328773-2, Rev. D) on the hook link assembly of the bomb rack. Before the latching screws are installed, the lock washers should be crimped and secured as shown on sheet 56. (Do not reinstall the lock washers, spacers, and/or cover discs removed in paragraph 6(a).
- c. With the revised latching screws secured in place, latch and release the bomb rack several times to insure proper operation. If there is any indication of binding between a pawl latching screw and the release lever assembly, remove the pawl latching screw and file or grind the threaded tip sufficiently to release the binding.

RESTRICTED

II FIELD REVISIONS

(IIL)

d. The longer latching screws on the subject bomb racks may interfere with the installation in certain type aircraft. In this case the long gripping surface of the latching screw may be cut off sufficiently to prevent fouling against the aircraft structure or other installations in the aircraft.

7. Disposition of Replaced Material

a. Scrap

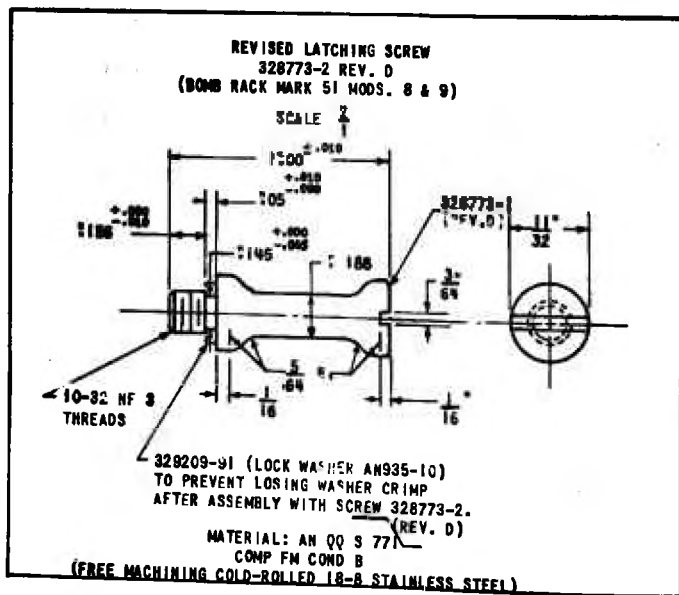

RESTRICTED

III PROCEDURE FOR ASSEMBLING RACK

III PROCEDURE FOR ASSEMBLING RACK

A. TOOLS FOR ASSEMBLING

Required

One light hammer
Two $\frac{3}{8}$ open end wrenches
Two $\frac{7}{16}$ open end wrenches
One medium screwdriver
One No. 2 Phillips head screwdriver

Helpful

A quarter inch thick steel block, preferably hardened, having $\frac{1}{4}$, $\frac{5}{16}$ and $\frac{3}{8}$ holes (for installing lock rings of those sizes)

A hooked wire about $\frac{1}{16}$ diam. (for pulling control cables thru frame grommets)

A center punch or $\frac{1}{8}$ rod (for pushing rubber plugs in place)

B. HOOK-LINK GROUP & RELEASE TRIGGER GROUP

1. Hook-link group (see sheet 74)

- a. First install in the frame the hook-link essem. 328763-1. Hooks face forward. Slip the unit in from the rear of the frame.
- b. Fit each hook with a $\frac{3}{8}$ diameter pivot pin 328785-36 using a washer 328773-1 on each side of each hook.
- c. Apply 328785-22 lockrings.

2. Release trigger group (see sheet 79)

- a. Install the release trigger group (omitting spring 328774-7 for the present) according to one of the following two methods:

(1) If a "blind" pin $\frac{5}{16}$ diameter, $\frac{7}{8}$ long is on hand:

- (a) Pull the pawl and link down below the frame and assemble trigger, link and spacers on the "blind" pin.

RESTRICTED

(IIIB)

III PROCEDURE FOR ASSEMBLING RACK

- (b) Pass these parts up into the rack.
 - (c) Align with 5/16 pawl link pivot hole in frame.
 - (d) Insert 5/16 pivot pin 328785-34, pushing the blind pin out the other side.
 - (e) Apply lockrings 328785-21.
- (2) If "blind" pin is not on hand:
- (a) Assemble the same parts by starting the pivot pin in its hole.
 - (b) Progressively add parts in correct order as the pin is worked in to hold them. This method is not as convenient as the first.

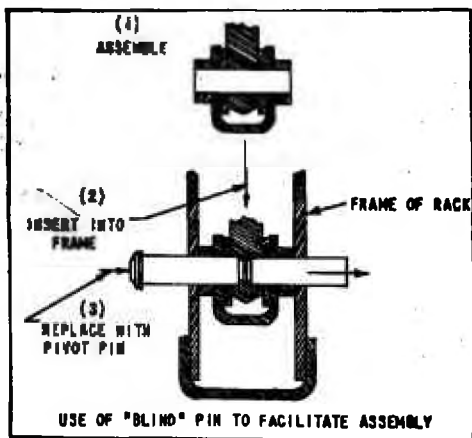

RESTRICTED

(IIIC)

III PROCEDURE FOR ASSEMBLING RACK

- b. Prepare for installation of spring 328774-7 by swinging the trigger down about 90° from its normal position.
- c. Install the spring, saddling the loop of the spring on the trigger end hooking the free ends on the release link.
- d. Push the trigger back to its normal position and thread the manual release cable up thru the brace grommet on top of the frame. A stiff hooked wire will help.
- e. Secure the cable with bushing 328773-28 placed in the loop.

3. Latching Screws(328773-2) (See section IIL)

Old Type: (High fillister head and 11/32 shank) Thread the screw thru lockwasher, 329209-11 (AN936A10) and clear cover 328773-9 in that order. Screw into release link 328763-7 (part of hook-link assem.-1) thru the 1-1/16 dia. holes on either side of frame.

New Type: (Spool shaped head and 5/32 shank) when the new screw (change D) is available, use with 329209-91 lockwasher (AN935-10) only. The clear cover disc is not to be used with this type screw.

CAUTION: If standard latching screws are unavailable, any substitute used must extend into the threaded hole in the link not over 3/16. A screw which projects inside the link will prevent release of the rack. Total length of screw shank should not exceed 3/8 inch when the clear cover is used, and 3/16 when the clear cover is not used.

C. RELEASE GROUP

1. Assembly of release unit. (see illustration sheets 75 and 76) (complete release units for use as replacements are assembled and adjusted at the factory. These notes are for emergency field use.)
 - e. Assemble rubber sealing cap 328772-7 over plunger of solenoid and fit around rim of solenoid with the vent hole in the cap on the same side as the solenoid lead. See part II section D.

RESTRICTED

III PROCEDURE FOR ASSEMBLING RACK

(IIIC)

- b. Fasten solenoid lead end "B" and "E" wires to micro-switch as shown on sheet 76, and install switch using the .140 end .156 diameter pins. Make sure all switch terminals lie in their channels.
- c. Install solenoid, using bolt end laminated washer as shown. Do not apply lockwire at this stage.
- d. Engage spring around latch lever and install latch lever in unit, first engaging the keyhole slot of the lever over the solenoid plunger. Fasten lever with temporary quarter inch pin.
- e. Make the adjustments called for on sheet 75.

2. Installation

- a. Thread the two cables "B" and "E" thru one 9/32" sideplate hole, (aft of the hoist bracket) from the inside. These cables must be passed out thru the side of the rack opposite the hoist bracket where the latter is used.
- b. Keeping the cables in the square notch of the release solenoid mounting lug, pass the release unit up into the frame.
- c. Temporarily bolt the end near the hoist bracket slot with any quarter inch bolt. (Selection and correct assembly of permanent bolt is explained under "Hoist Bracket Group".
- d. Swing the unit up on this bolt, while holding the hook-link assembly in the latched position by means of the latching screws.
- e. Install pivot pin 328785-31, with lockrings 328785-20 (see sheets 64 and 76)

Note: A blind pin one quarter inch in diameter by .87 long is helpful in holding internal parts in position until pivot pin is added. (Blind pin No. 323785-44)

3. Checking

Check the installation as follows:

- a. Latch the rack by the 328773-2 latch screws. Observe thru the 1-1/16" viewing hole. The pawl must latch on the brass release lever.
- b. Pull the manual release cable. Rack must release with strong spring action. (This indicates that the bronze release trigger has engaged the stirrup of the latch lever properly and that the 323774-7 torsion spring is properly fitted) *See VIIB4, Sh. 92

RESTRICTED

III PROCEDURE FOR ASSEMBLING RACK

(ITD)

- c. Latch the rack slowly. A faint click near mid-stroke indicates the transfer switch is operating correctly.
- d. The temporary bolt at the hoist bracket end of the release assembly may be left there until the bracket itself is installed.

D. ARMING GROUP

1. Assembly of arming unit. See sheet 78 for illustration and see detail instructions in Part II, sections C, E, and F.
2. Preliminary - Before installing arming unit checks:
 - a. To see that all micro switch terminals lie flat in their channels.
 - b. That the two grounding wires are properly soldered inside the stainless steel channel.
 - c. That the wire from the rear (tail) arming solenoid comes up to the others by passing outside of the U-shaped guard 328766-3.
 - d. That the nose arming solenoid has a branch wire with a flag terminal.
 - e. That the 3-7/8 inch long compression spring 328766-6 is in place on the brass plunger tube.
 - f. If the hoist bracket is to be used, BE SURE to insert special bolt 328773-7 thru the frame from the inside, and on the correct side so it will later be in position to hold the forward upper corner of the bracket. See sheet 80.
3. Installation
 - a. Pass the unit up into frame of rack, guiding the 3 lead cables with pin terminals out thru the 11/16 receptacle hole in the sideplate (the cables must go out to the side where the receptacle is to be mounted, usually the side opposite the hoist bracket)
 - b. The branch wire with flag terminal must stay inside the frame. It is brought forward from the arming unit and nested in the space between the frame end plate 328760-13. The flag terminal will later be connected to the smoke screen tank terminal. (See sheet 82)

RESTRICTED

III PROCEDURE FOR ASSEMBLING RACK

(XIII)

- c. In installing the unit, avoid rough handling which might damage the leaf spring of the micro switch. This spring is exposed so it bears against the front hook.
- d. Make sure that the arming plunger spring seats properly in the brass grommet on top of frame.
- e. Pull the manual cable up thru this spring with a hooked wire end fit bushing 328773-28 into the cable.
- f. Pass the two release unit lead cables which were previously carried forward outside the frame back into the arming unit thru the 9/32 hole below the 11/16 receptacle hole, and then out thru the latter. Five leads thus come out together.
- g. Make sure special hoist bracket bolt 328773-7 is in place, and on the proper side of the rack, if the hoist bracket is to be used. (Ref. para. 2F)
- h. Mount the unit with a temporary 1/4" bolt at the hoist bracket end.
- i. The other end is later mounted by the receptacle bolt. See "RECEPTACLE"

4. Checking

- a. slowly latch the rack. In addition to the click of the transfer switch in the release unit, there should also be a click from the indicator switch on the arming unit which is actuated by the front carrying hook.
- b. Pull the manual cable. The pull must be resisted by spring force, and the soft retainer must lock before the forward one.

E. ELECTRIC RECEPTACLE (See sheet 79)

1. Build the electrical receptacle up around the five lead cables previously brought out thru the 11/16 hole at the arming unit and extending about 3 inches out of the frame.
2. Pass a 329209-32 (AN23-42A) bolt thru 328774-3 bushing and into the opposite 11/16 hole, so that the shank of the bolt comes out with the 5 cables. This bolt mounts both the arming unit and the receptacle.

RESTRICTED

III PROCEDURE FOR ASSEMBLING RACK

(IIIF)

3. Slip phenolic tube 328774-5 on the bolt against washer 328774-3.
 4. Slip spacer 328774-4 and the casting 328773-11, which forms the base of the receptacle, over the 5 cables (arranged approximately in alphabetical order) and over the bolt and spacer tube.
 5. Put the plastic sleeve 328773-20 and the gasket 328773-19 in place on the base.
 6. Fit the five notch insulator 328773-17 in place between the 5 terminals and then the 5 hole insulator 328773-16 over the terminals. The two insulators meet and grip the $\frac{3}{32}$ diameter portion of the terminals. The polarizing notch of the upper insulator must be positioned to face the rack. The 5 pins must pass into correspondingly marked holes in the insulators.
 7. Drop the receptacle body casting 328773-15 down over the internal parts.
 8. Fasten by means of the 329209-32 (AN23-42A) bolt using self locking nut 328771-6 (AC365B1032)
- F. "HOIST BRACKET GROUP" OR "SLOT COVER GROUP" - (ALTERNATES)
SEE SHEET 80 & 81.

1. Selection

- a. The Hoist Bracket "Assembly" is used on both Mark 51 Mod 6 and Mod 7, for making up the Mod 6L, 7L (left hand hoisting) and 6R and 7R (right hand hoisting) variations. The bracket group consists basically of the bracket and one dust cover for the unused slot on the other side of the frame.
- b. The cover assembly is alternate to the bracket "assembly" on both Mod 6 and Mod 7, and is used for making up the Mod 6C and 7C (center hoisting) variations. The cover assembly consists basically of 2 dust covers for both sideplate slots. This cover assembly is for use when the only type loading intended is "center hoisting" wherein the bomb hoisting cable passes straight up thru the slot on top of rack frame.
- c. Both groups also include the shield which covers the release unit cables, and suitable fastenings.

RESTRICTED

III PROCEDURE FOR ASSEMBLING RACK

(IIIG)

2. Installation

- a. Arming and release unit installation instructions above specified only temporary 1/4" bolts at the hoist bracket ends. These should now be removed and replaced with suitable fastenings for either the bracket group or cover group, as required. See sheets 80 and 81.
- b. Special bolt 328773-7 has been previously called for when the hoist bracket was to be used. Because of space limitations this part had to be installed before the arming unit was inserted.
- c. For all other bracket or cover parts, see the sketches referred to above. Drawings show assemblies as viewed from left side of rack.
- d. Rubber plug called for may be pushed into place with a center punch or 1/8 inch rod.
- e. The cable shield 328773-8 may best be applied by sliding it over the two cables from the release unit end.

G. PIVOT PINS & LOCKRINGS

1. Installation

- a. Hold pivot pin vertical so it bears solidly on a metal base.
- b. Lay lockring concentrically on pin.
- c. Lay on the ring a block of metal with a hole the diameter of the pin. Usually a spare part of the kind being installed works well. (When pinning hooks use a spare hook, etc.)
- d. Strike this block or part with a light hammer. The ring will snap into the groove.
- e. It is usually convenient to put one ring on each pin before placing pin in the assembly.

2. Removal

- a. Lay assembly flat so the pin bears against a solid surface. (This puts the excess pin length on the working side)

RESTRICTED

III PROCEDURE FOR ASSEMBLING RACK

(IIII)

- b. Spread the ring by means of a screwdriver (or two if required) forced in between the ends of the ring.
- c. Diametrically opposite the opening in the ring pry ring up from groove with a knife.
- d. Do not re-use deformed rings.

E. MISCELLANEOUS

1. Smoke Tank Terminal

- a. See sheet ⁸² for method of assembly of live terminal at front of rack.
 - b. It is always mounted on left side.
 - c. This terminal is energized from the branch wire (with flag terminal) from the nose arming solenoid.
 - d. The smoke tank terminal screw used on racks with serial numbers above about 13,000 has a recessed head for #2 Phillips-head screw-driver.
2. The ground screws at rear 328771-12, one carrying a terminal 329209-111, (AC660-50) are also inserted at any time.

RESTRICTED

IV PROCEDURE FOR DISASSEMBLING RACK

IV PROCEDURE FOR DISASSEMBLING RACK

A. GENERAL

1. The Mark 51's may be disassembled without breaking any soldered electrical connections.
2. Most of the mechanism is contained in 3 principal sub-assemblies (hook and link assembly, arming unit and release unit, each of which is mounted by 2 bolts or pins)
3. Other parts, as electrical receptacle, hoist bracket and release trigger group and various shields are mounted on the same bolts so as to require a minimum of fastenings.

B. TOOLS REQUIRED

1. Two medium screwdrivers
2. Two 3/8" open end wrenches
3. Two 7/16" open end wrenches
4. A pocket knife
5. A light hammer
6. Two pins 7/8" long, one of 1/4" diam. and one of 5/16" dia. are helpful but not necessary.

C. ORDER OF DISASSEMBLY

1. Electrical receptacle may be entirely removed first.
2. Hoist bracket may also be removed first.
3. Arming unit may be removed after first disassembling the receptacle to free the cables of the arming unit.
4. Release unit may be removed after receptacle has been disassembled to free the release unit cables.
5. The manual release trigger group is removed after the parts listed above.
6. Hook and link assembly is the first installed into the frame, and the last removed. All other units must be out.

D. DETAIL PROCEDURES

1. Release Unit. To Remove:
 - a. Disassemble the electrical receptacle enough to free the "B" and "G" cables going to the release unit.

RESTRICTED

IV PROCEDURE FOR DISASSEMBLING RACK

- b. Loosen the cable shield.
- c. Remove the 1/4" bolt which holds the release channel (and also holds a corner of the hoist bracket)
- d. Remove one lockrings from the 1/4" pivot pin which holds the other end of the release channel and push a "blind" pin (1/4" dia. 7/8" long) in the hole in place of the regular pin. See III G, Sheet 64.
- e. Slip the release unit out clear of the frame. The "blind" pin serves to hold the internal parts in position. The use of the "blind" pin is helpful but not essential.

2. Arming Unit

- a. To remove the arming unit, remove the 329209-32 bolt by which the arming unit and the electrical receptacle are mounted.
- b. Disassemble the receptacle enough to free the "A" "C" and "D" cables.
- c. Remove the 1/4-28 mounting bolt which also holds a corner of the hoist bracket.
- d. Remove any rubber plugs entering the unit.
- e. Remove bushing 328773-28 by which the manual cable is pulled.
- f. Disassemble the smoke tank terminal at front of rack to free the nose arming solenoid branch cable.
- g. Withdraw the arming unit from the rack. Avoid using forward force tending to damage the micro switch leaf spring which bears against the front hook.

3. Hook-Link Unit & Release Trigger

- a. This unit includes carrying hooks and connecting links, plus the pawl and link of the release mechanism.
- b. The release and arming units must first have been completely removed.
- c. Remove the two 10-32 latching screws projecting thru the large holes in the sideplates.

RESTRICTED

IV PROCEDURE FOR DISASSEMBLING RACK

- d. Remove one locking from each pivot pin (two $3/8$ diameter pins, one $5/16$ diameter pin) and push these pins out.
- e. Remove bushing 328773-28 from the release cable at the top of the rack.
- f. Remove the bronze release trigger thru the bottom of the rack, together with its springs, washers and cable.

NOTE: The use of a "blind" pin $5/16$ diameter, $7/8$ long to push out the trigger pivot pin end to hold these parts together as they are pulled thru to the bottom of the rack will be found convenient.

- g. Slip the HOOK-LINK unit out thru either end of the rack.

4. Frame

Removal of the auxiliary ground terminal screws behind the rear hook lug and any hoist bracket group parts not already removed leaves the bare resistance-welded frame of the rack.

RESTRICTED

V MAINTENANCE

V MAINTENANCE

NavOrd OTI V16-44 (Section IIR in this book) covers routine maintenance of these racks and supersedes the maintenance instructions given in Ordnance Pamphlet 925.

RESTRICTED

II
ELECTRICAL CONNECTIONS

NOTES:

- (A) CURRENT VALUES ARE $\pm 10\%$ AND FOR 70° F. AS COILS HEAT CURRENT DECREASES
- (B) LARGER VALUES ARE FOR THE ORIGINAL SOLENOIDS WHICH SHOULD BE REPLACED WHEN POSSIBLE. THE SMALLER VALUES ARE FOR THE CONTINUOUS DUTY SOLENOID UNIT OF 1943 DESIGN.

RECEPTACLE CONNECTIONS	NOMINAL AMPERES (A)	
	MOD 7 (2KV)	MOD 6 (12V)
A - HOSE ARMING	1.2-0.5 (B)	2.1, 0.8 (B)
B - RELEASE	4.5	9.2
C - INDICATOR LIGHT	DEPENDS ON LAMP	DEPENDS ON LAMP
D - TAIL ARMING	1.2, 0.5 (B)	2.1, 0.5 (B)
E - TRANSFER TO NEXT STATION	4.5	9.2

SOLENOIDS
- .15 IN. REV. T
(1944)

POLARIZING WIRE
TOWARDS BACK

TYPE SC-140 -50
RECEPTACLE ON BACK

SOLENOID WIRE TO "C" TERMINAL ON SWITCH

NEXT STATION WIRE TO "O" TERMINAL ON SWITCH

BACK MAY BE GROUNDED BY USE OF CLEAN MTG. BOLTS FREE OF PAINT OR GREASE OR BY GROUND TO TERMINAL AT (e).

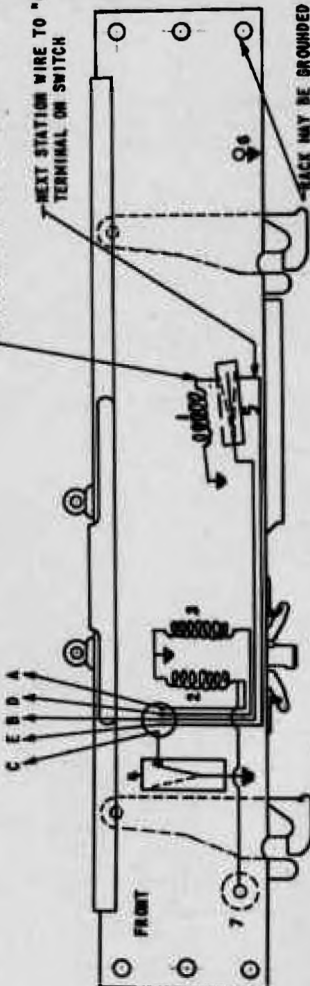

ELECTRICAL UNITS:

1. RELEASE SOLENOID
2. HOSE ARMING SOLENOID
3. TAIL ARMING SOLENOID
4. INDICATOR LIGHT SWITCH (S.P.R.O. LEAF TYPE MICRO SWITCH)
5. RELAY (I.e. TRANSFER OR NEXT STATION) SWITCH (S.P.D.T. STANDARD MICRO SWITCH)
6. GROUND TERMINAL
7. SIDE PLATE (NOT) TERMINAL (10-32 SCREW, JAM NUT AND LOCK W/T) ATTACHED TO HOSE ARMING SOLENOID CIRCUIT

RESTRICTED

 VI
 MANUAL CABLE MOVEMENTS & FORCES

THESE VALUES ARE UP TO DATE AS OF 9/29/44 WHEN TOLERANCE ON "C" (\pm) IN ARMING WAS MADE $+1/8$ IN PLACE OF $+1/16$ AND LOAD ON "E" ($\#$) IN ARMING WAS REMOVED.

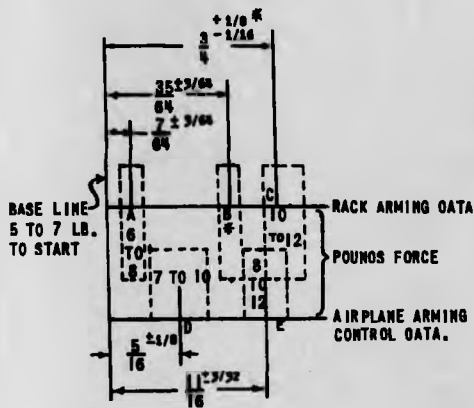

A	ARMS TAIL
B	ARMS TAIL & NOSE
C	FULL STROKE

D	ARMS TAIL
E	ARMS TAIL & NOSE

ARMING CABLE

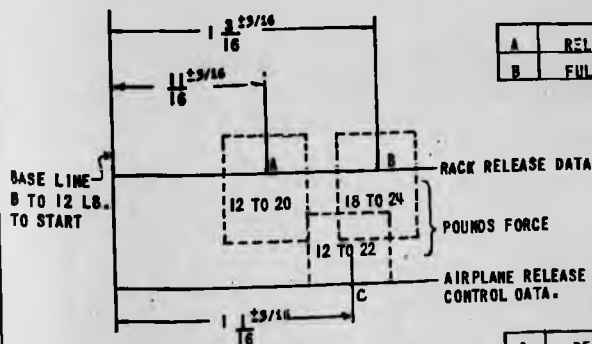

A	RELEASES
B	FULL STROKE

C	RELEASES
---	----------

RELEASE CABLE

RESTRICTED

VI
METHODS OF LATCHING RACK

SCALE $\frac{1}{4}$

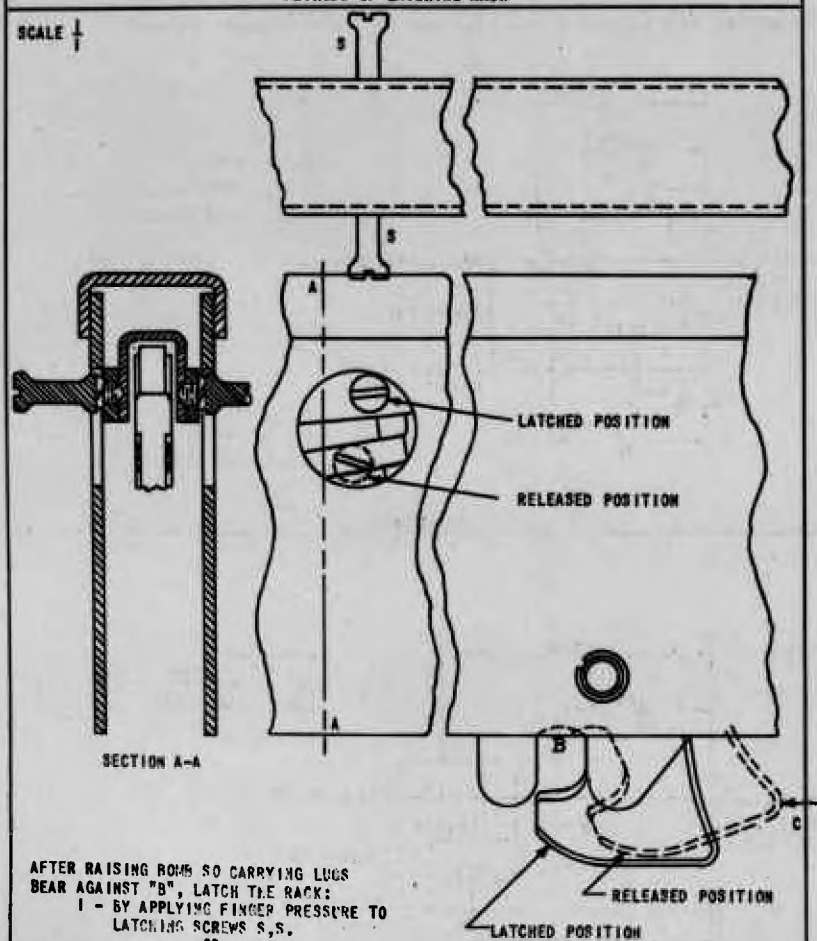

AFTER RAISING BOMB SO CARRYING LUGS
BEAR AGAINST "B", LATCH THE RACK:

1 - BY APPLYING FINGER PRESSURE TO
LATCHING SCREWS S,S.

OR

2 - BY A SHARP THRUST APPLIED AGAINST
THE HEEL (POINT "C") OF EITHER
CARRYING BODY BY A STICK OR ROD.

RESTRICTED

VI
CONSTRUCTION OF COMPLETE RACK
SHOWING PRINCIPAL SUBASSEMBLIES

SCALE $\frac{1}{4}$

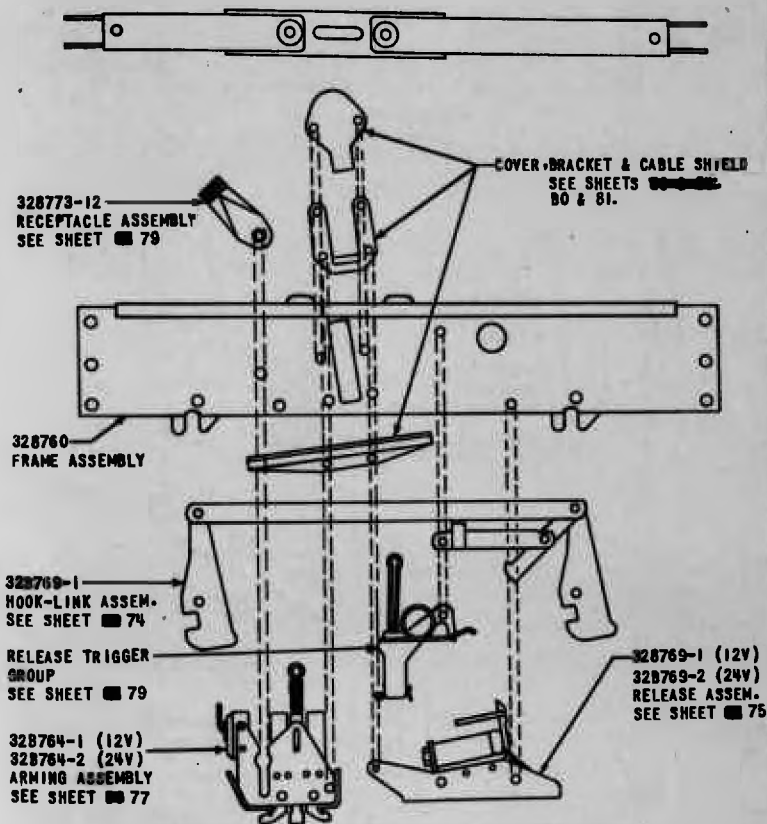

FOR MINOR ITEMS NOT INCLUDED IN ANY OF THE ABOVE SUB-
 ASSEMBLIES, SEE SHEET 82
 FOR IDENTIFYING SKETCHES OF SPACERS, FASTENINGS AND OTHER
 SMALL PARTS, SEE SHEETS 83 TO 88.

RESTRICTED

II
HOOK AND LINK ASSEMBLY

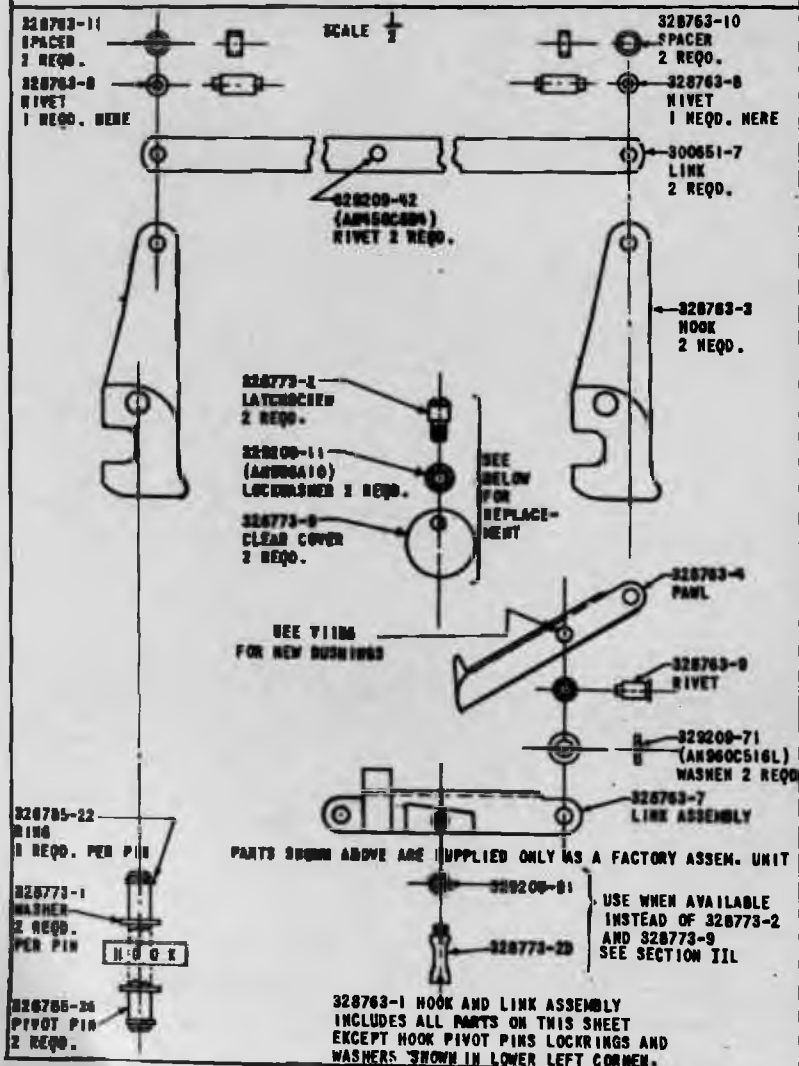

RESTRICTED

II

RELEASE ASSEMBLY, INCLUDING ADJUSTMENTS

SCALE $\frac{1}{1}$

ASSEMBLY NUMBERS:

328769-1 FOR MOD 6 (12 VOLT)
 328769-2 FOR MOD 7 (24 VOLT)

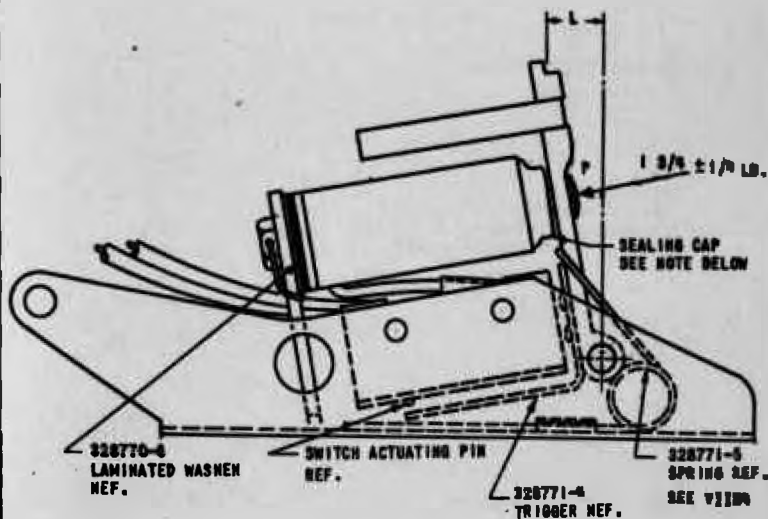

ADJUSTMENT

1. ADJUST LAMINATED WASHER 328770-6 TO MAKE "L" = .706 ± .010 WITH SOLENOID PLUNGER FULLY IN. (WASHER IS 1/16 THICK AND ANY DESIRED NUMBER OF .003 LEAVES MAY BE PEELED OFF)
2. THEN BEND TRIGGER 328771-4 SO SWITCH SNAPS WHEN "L" IS BETWEEN .480 AND .500
3. STIFFNESS OF SPRING 328771-5 MUST BE SUCH THAT 1-3/4 ± 1/4 LB. APPLIED AXIALLY AT POINT "P" WILL MOVE THE PLUNGER IN.

SEALING CAP

A NEW CAP IS NOW AVAILABLE WHICH IS OF A SYNTHETIC COMPOSITION WHICH RETAINS ITS FLEXIBILITY DOWN TO MINUS 50 DEGREES FAHRENHEIT. ALL OLD CAPS SHOULD BE REPLACED. DIMENSION "A" AND A COLORED SPOT SERVE TO DISTINGUISH NEW CAPS FROM OLD. SEE SECTION [REDACTED] FOR IDENTIFICATION AND INSTALLATION. WHEN INSTALLING CAP KEEP DRAIN HOLE ON SAME SIDE AS SOLENOID LEAD WIRE, THAT IS, DOWN.



RESTRICTED

II

CONSTRUCTION OF RELEASE ASSEMBLY

SCALE $\frac{1}{2}$

328789-2 MK 51 MOD 7 (24 VOLT)
 328709-1 MK 51 MOD 8 (12 VOLT)
 EACH INCLUDES A SOLENOID AS LISTED
 AND ALL OTHER PARTS SHOWN

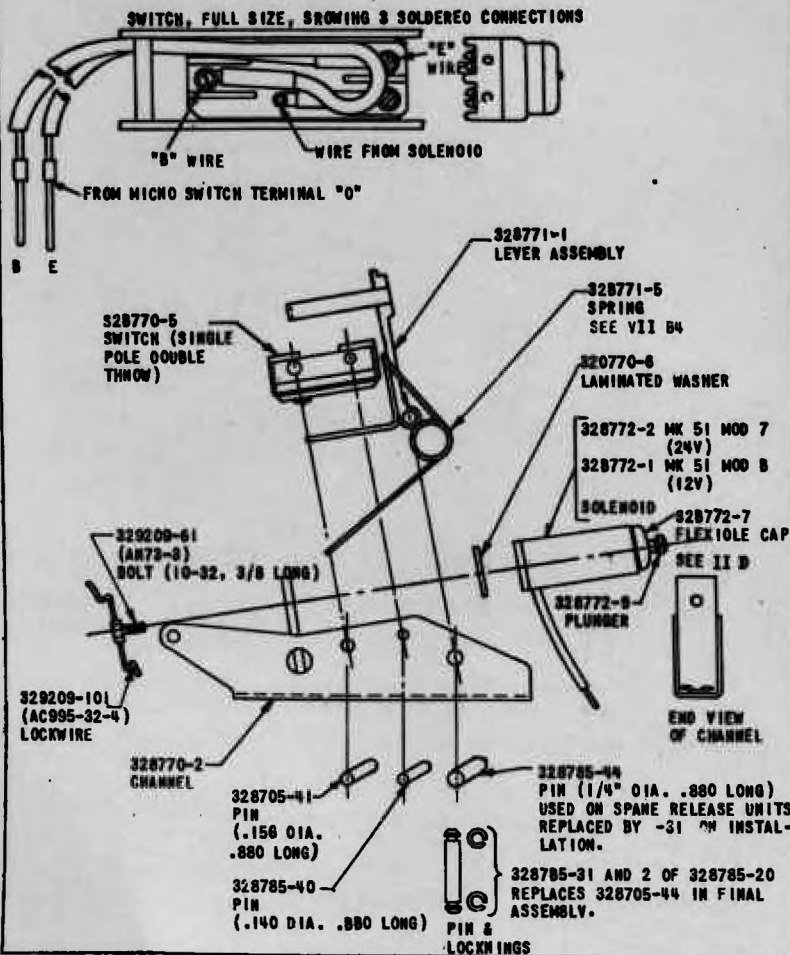

RESTRICTED

VI
ARMING ASSEMBLY INCLUDING WINING DETAIL

SCALE $\frac{1}{8}$

ASSEMBLY NUMBERS:

328704-1 FOR MOD 0 (12 VOLT)

328704-2 FOR MOD 7 (24 VOLT)

CABLE MARKINGS:

MARKER ON NOSE ARMING SOLENOID WIRE IS LABELED "A"
ON TAIL ARMING SOLENOID "O"
ON LIGHT SWITCH CABLE "C"

S28773-10

PIN FOR INSERTION INTO RECEPTACLE S28773-13

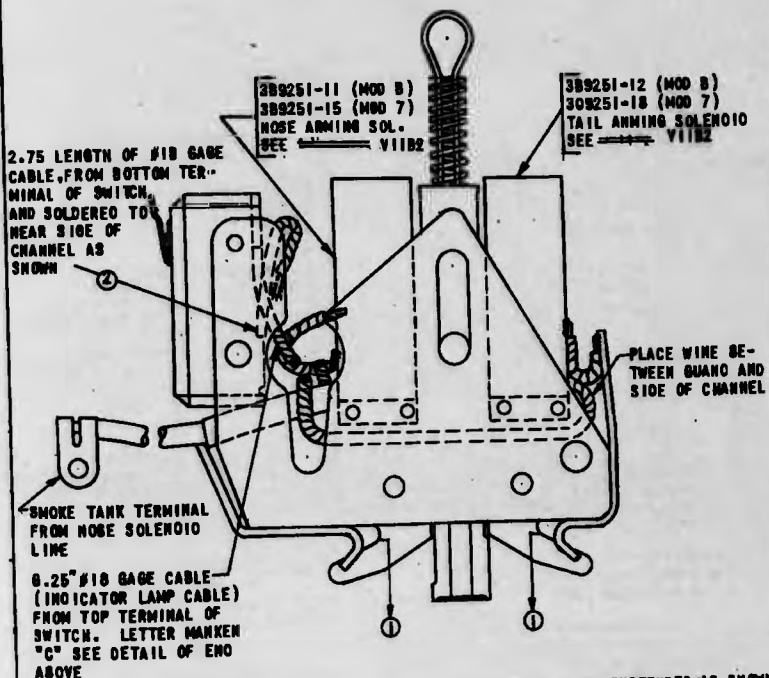

1. EACH RETAINER MUST SUPPORT A 2LB. LOAD OUT DROP A 4LB. LOAD SUSPENDED AS SHOWN AND ON A STANOARD NAVY BOMB ARMING WIRE TERMINAL (MADE FROM .060 SHEET STOCK) OR EQUIVALENT. STIFFNESS OF SPRING MUST CONFORM TO THESE REQUIREMENTS.
2. SWITCH TERMINAL CONNECTIONS ARE MADE BY SOLDERING TO TERMINAL SUPPLIED WITH HIGH MARINE PRODUCTS SOLDERLESS "DIAMOND GRIP" TERMINAL #31094 OR EQUIVALENT. TIGHTEN SWITCH TERMINAL SCREWS WITH 40 TO 50 INCH OUNCES TORQUE.
3. EACH ARMING SOLENOID MUST BE BONDED TO THE MAIN CHANNEL BY A SHORT LENGTH OF #18 CABLE. THE BOND IS SUPPLIED ON THE NEW CONTINUOUS DUTY SOLENOIDS.

RESTRICTED

VI
CONSTRUCTION OF ARMING ASSEMBLY

SCALE $\frac{1}{2}$

COMPLETE UNIT:

- 328764-2 MK 51 MOD 7 (24V)
- 328764-1 MK 51 MOD 8 (12V)
- EACH INCLUDES SOLENOIDS AS LISTED AND ALL OTHER PARTS SHOWN

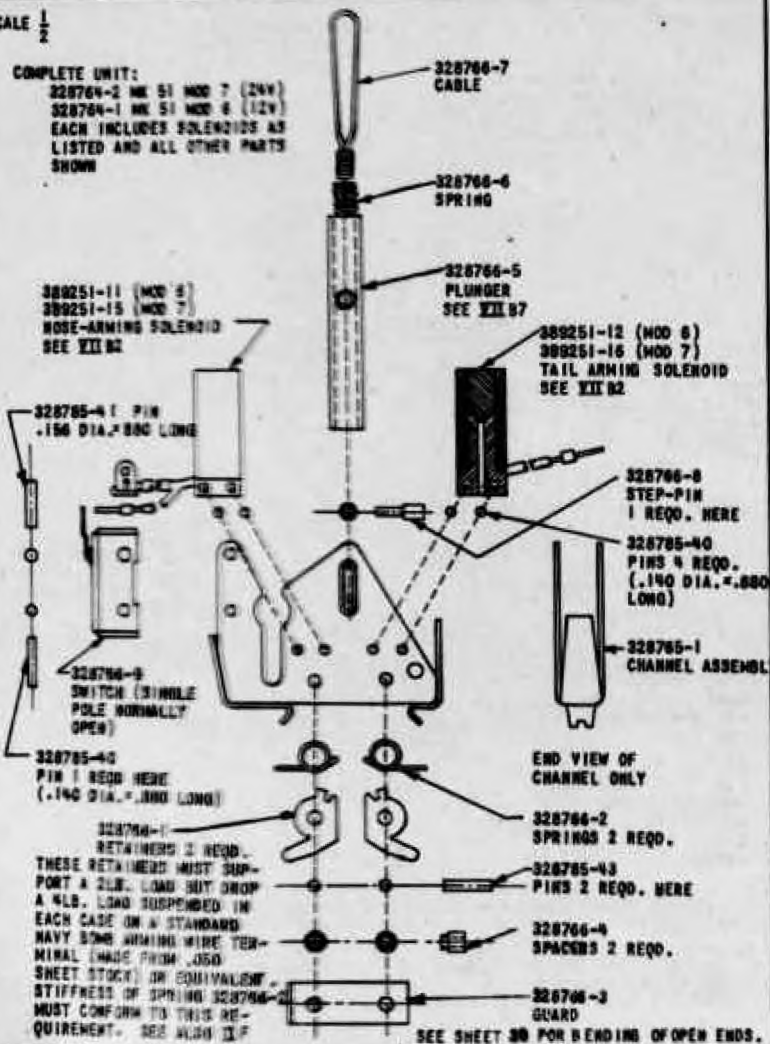

RESTRICTED

XI

CONNECTOR ASSEMBLY AND TRIGGER ASSEMBLY

SCALE +

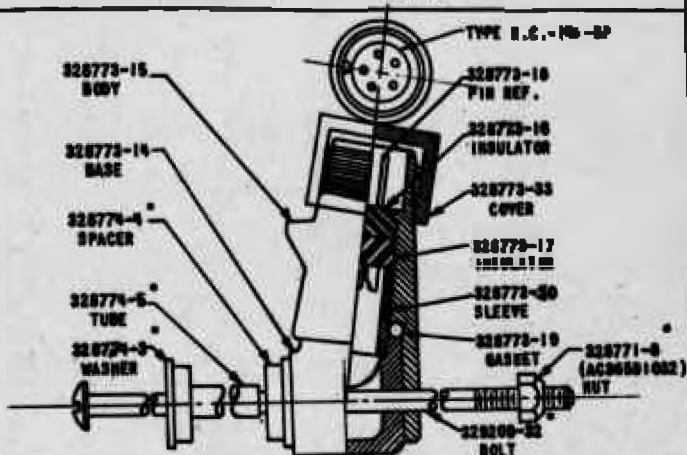

328773-15 RECEPTACLE ASSEMBLY INCLUDES ALL PARTS, EXCEPT MOUNTING NUT, BOLT, SPACER, WASHER AND TUBE (DESIGNATED WITH *)

328773-12 CONNECTOR ASSEMBLY INCLUDES ALL PARTS SHOWN ABOVE

SCALE +

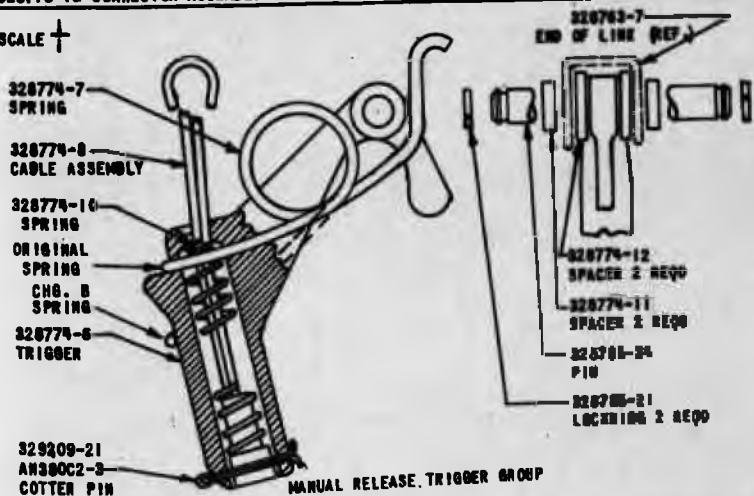

MANUAL RELEASE TRIGGER GROUP

RESTRICTED

VI
CONSTRUCTION OF ARMING ASSEMBLY

SCALE $\frac{1}{2}$

COMPLETE UNIT:

328764-2 MK 51 MOD 7 (24V)
328764-1 MK 51 MOD 6 (12V)
EACH INCLUDES SOLENOIDS AS LISTED AND ALL OTHER PARTS SHOWN

388251-11 (MOD 6)
388251-15 (MOD 7)
NOSE-ARMING SOLENOID
SEE XII B2

328785-4 T PIN
.156 DIA. x .800 LONG

328766-9
SWITCH (SINGLE
POLE NORMALLY
OPEN)

328785-40
PIN 1 REQD HERE
(.140 DIA. x .800 LONG)

328766-1
RETAINERS 2 REQD.
THESE RETAINERS MUST SUPPORT A 2LB. LOAD BUT DROP A 4LB. LOAD SUSPENDED IN EACH CASE ON A STANDARD NAVY BOMB ARMING WIRE TERMINAL (MADE FROM .050 SHEET STOCK) OR EQUIVALENT. STIFFNESS OF SPRING 328766-2 MUST CONFORM TO THIS REQUIREMENT. SEE ALSO IIF

328766-7
CABLE

328766-6
SPRING

328766-5
PLUNDER
SEE XII B7

388251-12 (MOD 6)
388251-16 (MOD 7)
TAIL ARMING SOLENOID
SEE XII B2

328766-8
STEP-PIN
1 REQD. HERE

328785-40
PINS 4 REQD.
(.140 DIA. x .800 LONG)

328765-1
CHANNEL ASSEMBLY

END VIEW OF
CHANNEL ONLY

328766-2
SPRINGS 2 REQD.

328785-43
PINS 2 REQD. HERE

328766-4
SPACERS 2 REQD.

328766-3
GUARD

SEE SHEET 80 FOR BENDING OF OPEN ENDS.

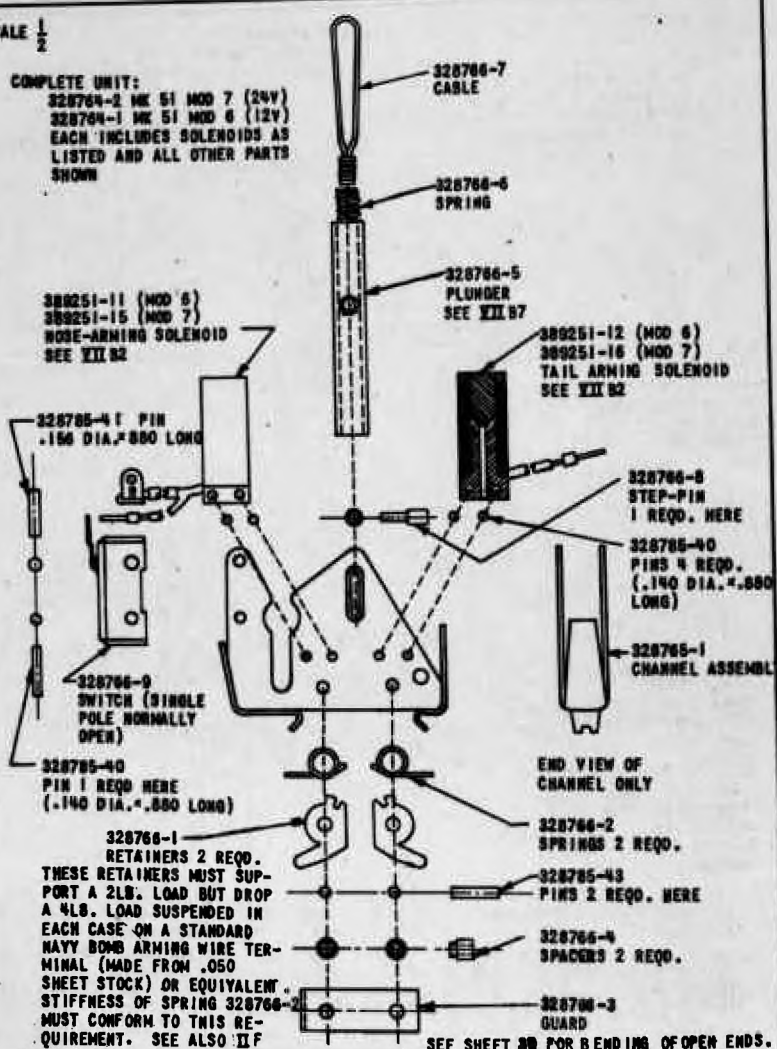

RESTRICTED

II

CONNECTOR ASSEMBLY AND TRIGGER ASSEMBLY

SCALE †

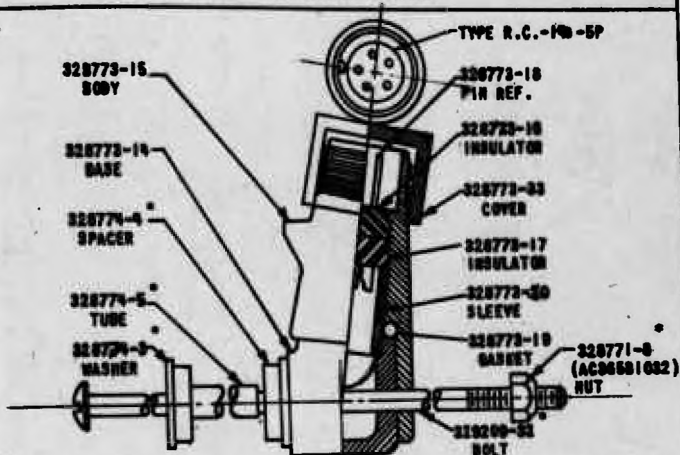

328775-13 RECEPTACLE ASSEMBLY INCLUDES ALL PARTS, EXCEPT MOUNTING NUT, BOLT, SPACER, WASHER AND TUBE (DESIGNATED WITH *)

328773-12 CONNECTOR ASSEMBLY INCLUDES ALL PARTS SHOWN ABOVE

SCALE †

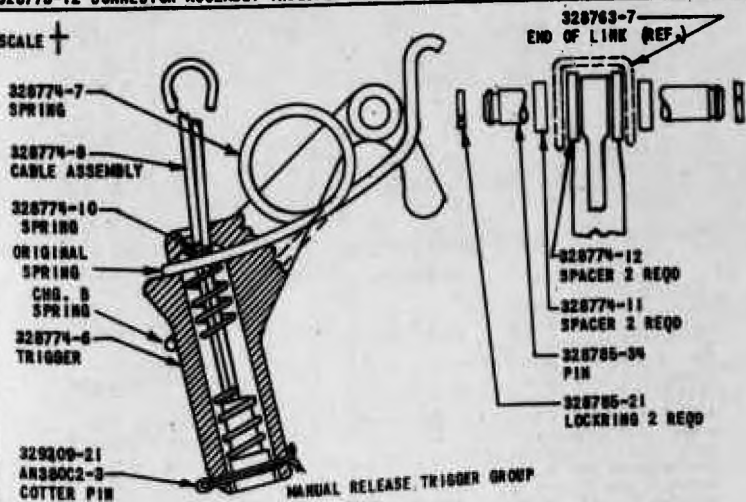

RESTRICTED

II
HOIST BRACKET GROUP

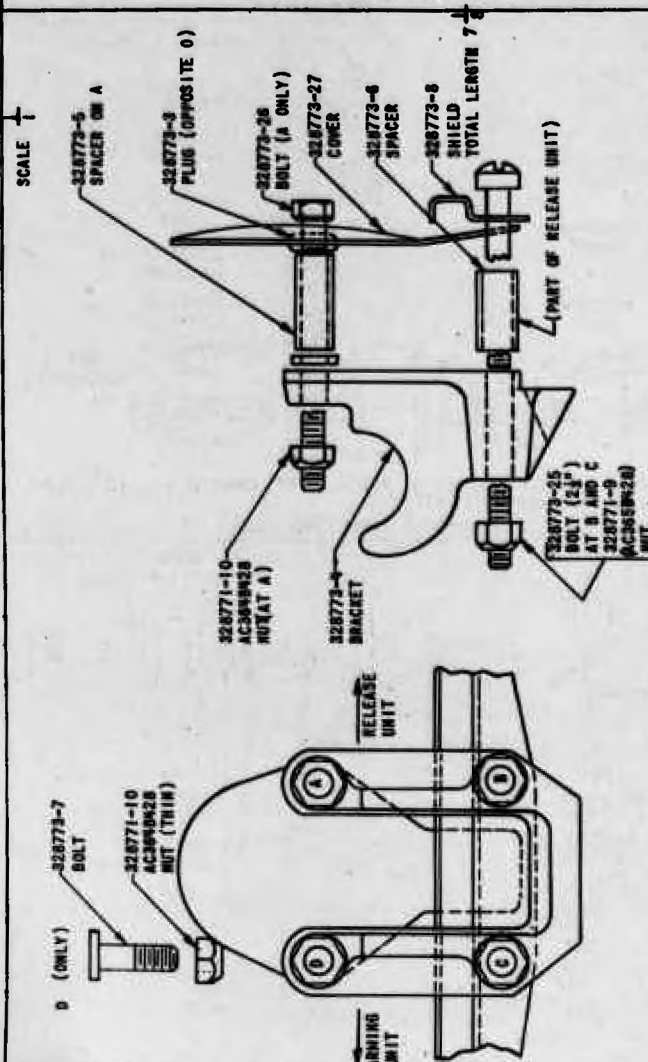

1. THIS "HOIST BRACKET GROUP" IS STANDARD ON MDDS 6L, 6B, 7L, 7B. IF RACKS ARE ORDERED FOR CENTER HOISTING ONLY (MDDS 6C, 7C) THEY WILL BE SUPPLIED WITH THE COVER ASSEMBLY GROUP SHOWN ON SHEET-80 6L.
2. ASSEMBLY SHOWN MADE UP FOR LEFT SIDE. RIGHT HAND OPPOSITE USING SAME PIECES.
3. BOLTS A AND D MUST BE MADE OF 125,000 P.S.I. STOCK.

RESTRICTED

VI
SLOT COVER GROUP

SCALE +

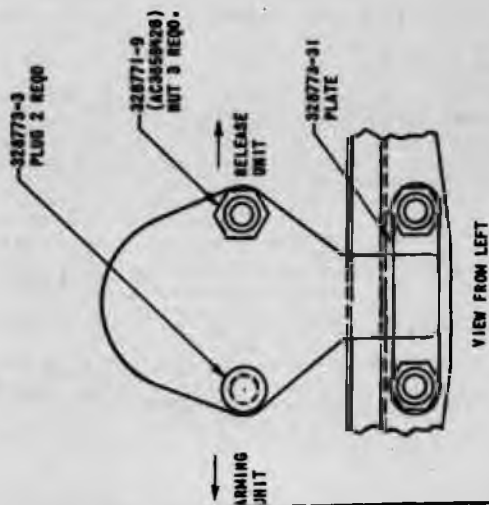
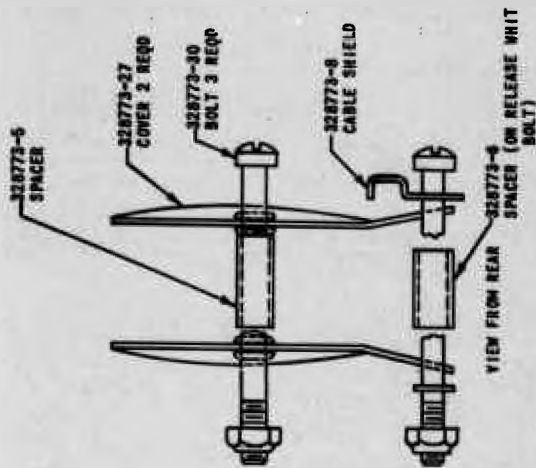

THIS "SLOT COVER GROUP" IS USED ON CENTER HOIST RACKS ONLY (MOOS. 6C, 7C) TO CLOSE THE UNUSED HOISTING-SHEAVE SLOTS. THESE PARTS REPLACE THE HOIST BRACKET GROUP SHOWN ON SHEET 80.

RESTRICTED

VI
MISCELLANEOUS PARTS
INCLUDING ACCESSORY TERMINAL

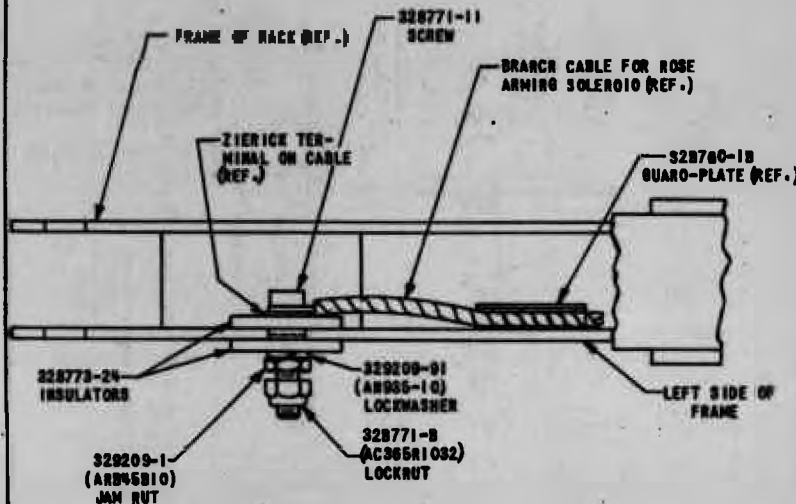

"LIVE" ELECTRIC ACCESSORY TERMINAL
 (VIEW LOOKING DOWN ON FRONT END OF FRAME;
 RIG LUGS OMITTED FOR CLARITY.)

PARTS SHOWN ON THIS SHEET ARE MISCELLANEOUS DETAILS NOT CALLED FOR ON ANY OF THE PRINCIPAL SUBASSEMBLY GROUPS SHOWN ON SHEET 7B. THESE PARTS INCLUDE

SEE SHEETS 63
 TO 64
 FOR SKETCHES

- ALL DETAIL PARTS SHOWN ABOVE FOR BOMB TARK "LIVE" TERMINAL AT FRONT OF BACK AND:
- 5 OF 328773-32 RUBBER PLUGS (TO CLOSE THE 11/32 HOLE OPPOSITE LIVE TERMINAL AND 2 MORE AT OTHER END OF RACK)
- 2 OF 328773-3 RUBBER PLUGS (TO CLOSE THE 9/32 HOLES OPPOSITE THOSE COVERED BY CABLE SHIELD 328773-8 THESE ARE IN ADDITION TO THESE CALLED FOR ON SHEETS 63 & 64.
- 2 OF 328773-2B BUSHINGS INSIDE LOOP OF MANUAL ARMING AND RELEASE CABLES.
- 2 OF 328771-12 SCREWS USED FOR BOMB TARK GROUND TERMINALS AT REAR OF RACK.
- 1 OF 329209-111 WIRE TERMINAL FOR USE ON ONE OF THE -12 SCREWS ABOVE.

RESTRICTED

VI
IDENTIFICATION OF WIROR PARTS

SCALE, ENTIRE SHEET, +

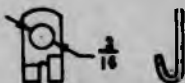

#151 ZIERICK MFG. CO. "FLAG" TERMINAL
USE: ON BRANCH CABLE OF ROSE ARMING
SOLENOIDS

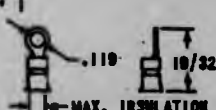

A.M.P. #51006 (AIRCRAFT MARINE PRODUCTS)
SOLDERLESS TERMINAL
USE: AS ALTERNATE TO ORIGINAL TERMINALS
OR MICRO SWITCHES

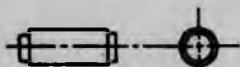

328763-8 RIVET, ROOK LINK STEP
USE: AT EACH END OF ROOK-LINK ASSEMBLY

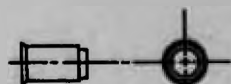

328783-9 RIVET, PAWL LINK STEP
USE: TO ASSEMBLE RELEASE PAWL AND LINK

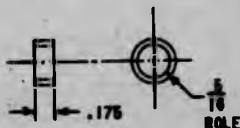

328763-10 SPACER, ROOK LINK REAR
USE: ON RIVET AT TOP OF REAR ROOK

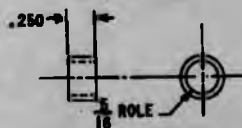

328763-11 SPACER, ROOK-LINK FRONT
USE: ON RIVET AT TOP OF FRONT ROOK

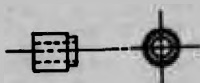

328786-4 SPACER
USE: ON EITHER SIDE OF EACH ARMING
RETAINER

RESTRICTED

VI
Identification of Minor Parts

Scale, Entire Sheet, $\frac{1}{8}$ "

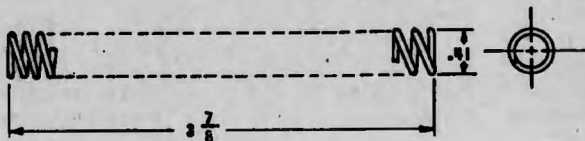

328766-6 SPRING, ARMING RETAINER

USE: INSIDE PLUNGER TUBE OF MANUAL ARMING CONTROL.

328766-7
CABLE, ARMING

USE: TO OPERATE
MANUAL ARMING
CONTROL TUBE

NOTE DIFFERENCE
FROM RELEASE CABLE

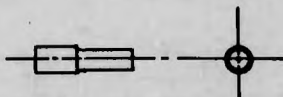

328766-8 PIN, STEP

USE: FOR INSTALLING MANUAL ARMING
CONTROL TUBE 328766-5

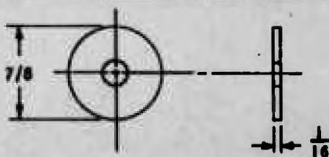

328770-6 WASHER, SOLENOID ADJUSTING
MADE OF .003 LAMINATIONS WHICH MAY BE
SPLIT OFF TO REDUCE THICKNESS

USE: TO POSITION RELEASE SOLENOID



328771-11 SCREW AND WASHER

USE: FOR MOUNTING LIVE TERMINAL
AT FRONT OF RACK



328771-12 SCREW AND WASHER

USE: AS GROUND TERMINAL AT
REAR OF RACK

RESTRICTED

VI
IDENTIFICATION OF IRON PARTS

SCALE: ENTIRE SHEET, $\frac{1}{4}$ "

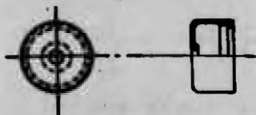

328772-7 RUBBER CAP
USE: OVER RELEASE SOLENOID PLUNGER
IMPORTANT: SEE II D FOR LOW TEMPERATURE COMPOSITION CAPS

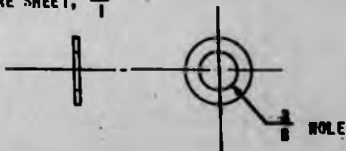

328773-1 WASHER
USE: ON $\frac{3}{8}$ " PIVOT PINS, ON EITHER SIDE OF EACH HOOK

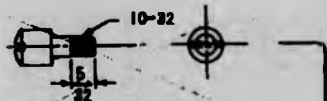

328773-2 SCREW, LATCH
USE: PROJECT THRU $1\text{-}1/16$ " FRAME HOLES FOR LATCHING RACK
NOTE: TO BE REPLACED BY 328773-2D WHEN AVAILABLE SEE IIL



328773-3 PLUG (SYNTHETIC NUMBER)
USE: TO CLOSE UNUSED $1/4$ " HOLES ON FRAME

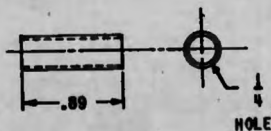

328773-5 SPACER
USE: ON UPPER REAR HOIST BRACKET BOLT



328773-6 SPACER
USE: ON LOWER REAR HOIST BRACKET BOLT

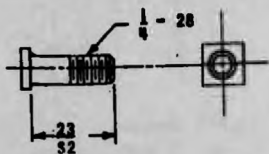

328773-7 BOLT
USE: TO MOUNT HOIST BRACKET

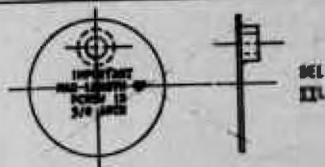

328773-9 COVER (CLEAN)
USE: WITH 328773-2 TO COVER $1\text{-}1/16$ " HOLE. DO NOT USE WITH 328773-2D

RESTRICTED

VI
IDENTIFICATION OF MINOR PARTS

SCALE, ENTIRE SHEET



328773-16 "5 HOLE" INSULATOR
USE: AT TOP OF RECEPTACLE

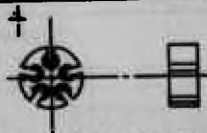

328773-17 "5 ROTCH" INSULATOR
USE: IN RECEPTACLE, UNDER 328773-16



328773-19 GASKET (RUBBER)
USE: IN RECEPTACLE

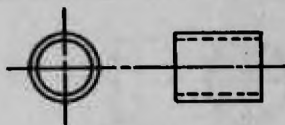

328773-20 SLEEVE
USE: IN RECEPTACLE



328773-24 INSULATOR
USE: UNDER "LIVE" TERMINAL AT
FRONT OF RACK

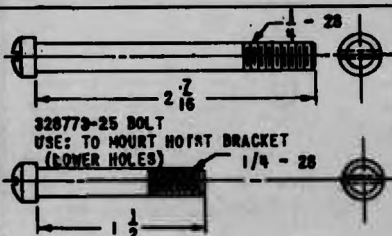

328773-25 BOLT
USE: TO MOUNT HOIST BRACKET
(LOWER HOLES)

328773-30 BOLT
USE: TO MOUNT HOIST BRACKET SLOT COVERS

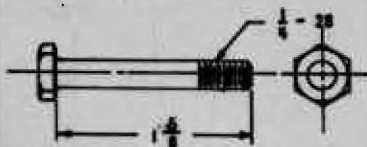

328773-26 BOLT
USE: TO MOUNT HOIST BRACKET
(UPPER HOLE)



328773-28 BUSHING
USE: FITS IN LOOP OF MANUAL
CONTROL CABLES AT TOP OF RACK

RESTRICTED

VI

IDENTIFICATION OF MINOR PARTS

SCALE, ENTIRE SHEET, $\frac{1}{4}$ "

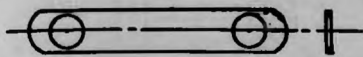

328773-31 PLATE, COVER RETAINER
 USE: TO HOLD LOWER TAB OF COVER
 328773-27 IN PLACE.

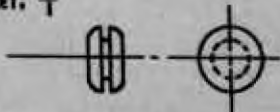

328773-32 PLUG, REOPRENE
 USE: ON FRAME TO PLUG 11/32 HOLES

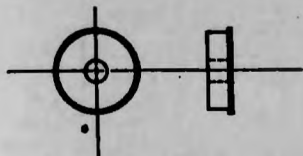

328774-3 WASHER
 USE: ON RECEPTACLE MOUNTING BOLT

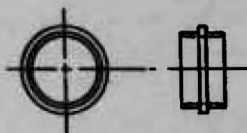

328774-4 SPACER
 USE: TO HOLD RECEPTACLE OUT FROM
 \ SIDEPLATE OF RACK

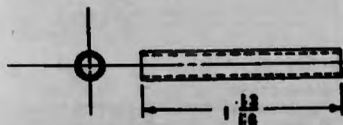

328774-5 TUBE, PHENOLIC
 USE: ON RECEPTACLE MOUNTING BOLT



328774-8 CABLE, RELEASE
 USE: TO OPERATE
 MANUAL RELEASE
 NOTE DIFFERENCE
 FROM ARMING CABLE

RESTRICTED

VI
IDENTIFICATION OF MINOR PARTS

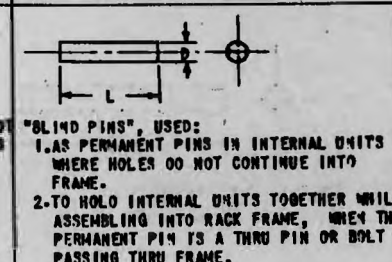
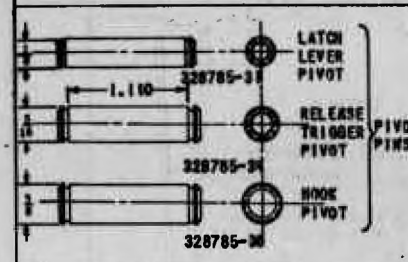
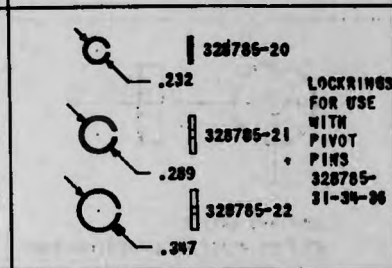
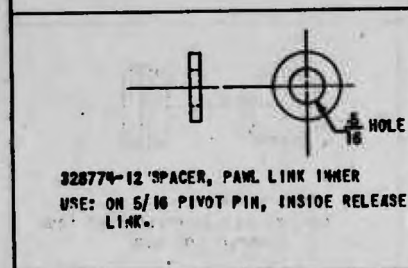
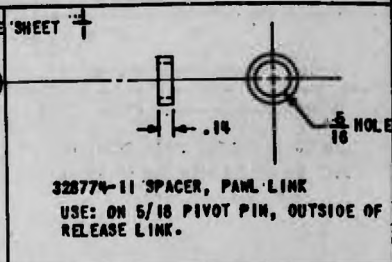
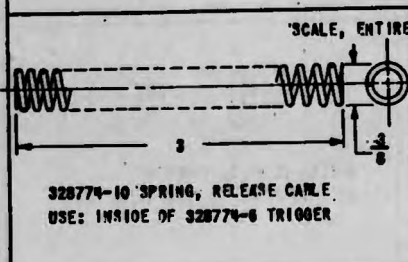

PART NUMBERS:

	O	L	MAT'L
328785-40	.140	.880	BRASS
-41	.156	.880	BRASS
-43	.187	.880	BRASS
-44	.250	.880	C. STEEL
-49	.312	.880	C. STEEL

RESTRICTED

VII INDEX TO CHANGES; NOTES ON CHANGES

A. INDEX

The following index gives the location of changes and change instructions described in this book. The items are grouped according to the part of the bomb rack in which they are used. This complete index of changes is given so that users can identify racks which are not up to date. If the station in question cannot perform the required work, the racks should be turned in to control depots which can do so.

ITEM	INTRO-DUCED?	LOCATION; REMARKS
Release unit subassembly Cap, solenoid low temperature Spring, latch lever return (new) Washer, solenoid backing Wire color coding	a b b see	IID VIIIB VIIIB5 "receptacle"
Arming unit subassembly Guard, retainer (banding of) Plunger (cutoff) Retainers Solenoids Original design 1945 design, installation " " , crimping of base 1944 design, installation Wire color coding	b b 8&9 a a a 8&9 see	IIF5 item 11a VIIIB7 IIF, IIK3 (a4, b3, b4) IIB5; VIIIB2 IIC, IIK3 (a-1, a2, b2), IIB6a(2)(b), VIIIB2 VIIIB5 VIIIB2 receptacle
Arming units, temporary, (AN-A-1, AN-B-1), use of	a	IIB, VIIIB2
Hook, link and toggle assem. Bushings, bronze toggle Screws, latching	b 8&9	VIIIB6 IIK4; IIL, Sk. on ch. 74
Receptacle Wire color coding	a	IIE
Locking pin Safety pin	a	IIA (not necessary if ground check pin is provided)
Ground check	8&9	IIG
General Coatings Tectyl, use of Tectyl, damage by; removal of	a	use discontinued; see below IIB2 a(2) IIK3a(3), 3b(2), 6a(1), 6b(1), 7a(1), 7b(1) and (2) IIB6,
Plating, chromate dip, lacquer- ing, greasing	b	IIK7b(3), IIB

RESTRICTED

VII INDEX TO CHANGES; NOTES ON CHANGES

(VIIB)

ITEM	INTRO-DUCED†	LOCATION; REMARKS
Cables, manual Spare part numbers	- 8&9	IIS IIB61

†Notation in "introduced" column

a - introduced prior to Mod 8 & 9

8&9 - introduced at beginning of Mod 8 & 9 production

b - introduced during Mod 8 & 9 production as available

B. NOTES ON CHANGES

1. These notes explain

(a) differences between successive designs, where necessary

(b) certain minor changes made in the Mark 51 bomb racks



which are not specifically covered by existing ordnance publications. (The latter are compiled in section II in this book)

All items discussed herein are listed in the above index.

2. ARMING SOLENOIDS, SUCCESSIVE TYPES

The following tabulation is given to make clear the differences between the several designs and the order in which they replace one another. For more detailed information see the index above.

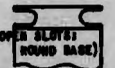
Type	Nominal Resistance		Defects	Replace with
Orig.	12V	24V	May burn out after 20 min.	1944 type (preferred) (instructions in IIC) or AN-A-1 or AN-B-1 units (instructions in IIB)
	5	20		
1943	20	50	May burn out in 1 or 2 hours; may stick	
1944	20	155		

	Marking on Solenoid	Stock No.	Type of Base
Orig.	410331-() or 328768-()		
1943	389251-() and "C"	12V nose 12V tail 3-3-3386-25 24V nose 24V tail 3-3-3386-50	
1944	389251-() "C" and Rev. F	12V nose 12V tail 24V nose 3-3-3475 24V tail 3-3-3475	

RESTRICTED

VII INDEX TO CHANGES; NOTES ON CHANGES

WED (CONT'D)

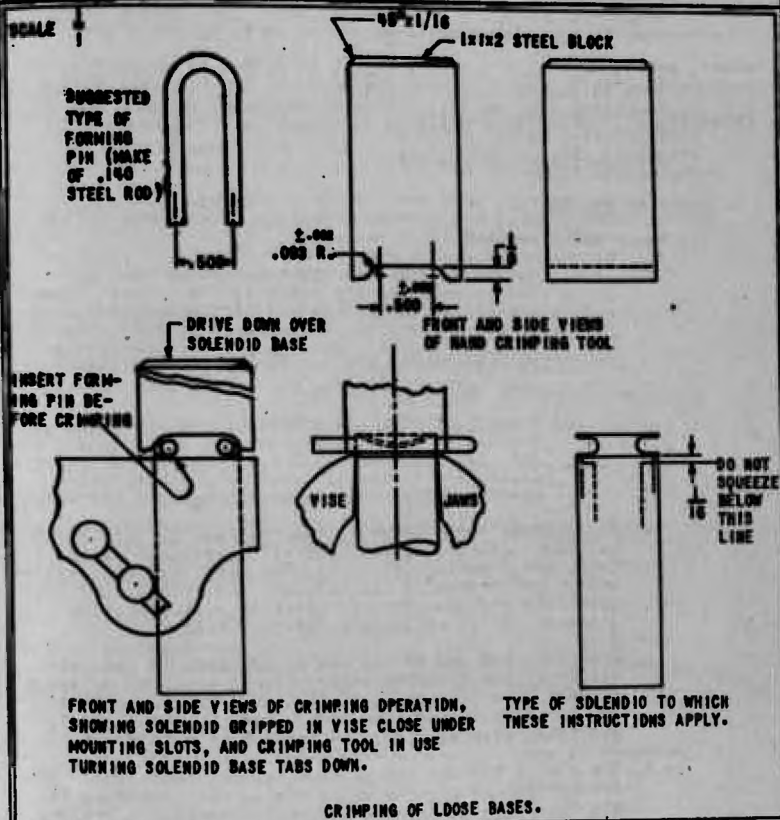

3. ARMING SOLENOIDS; SLOTTED BASE TYPE, crimping of loose bases

The first, that is, "1943", design of continuous duty solenoid has a round base, and is mounted by open slots into which the .140 diameter "blind" pins fit. It has been found that these slots sometimes allow too much play when the solenoid is mounted. The above method has been approved by BuOrd for crimping the bases to tighten the solenoids. See Sketches.

It is suggested that loose bases on solenoids of this type be made tight by this method if it is not possible to replace

RESTRICTED

VII INDEX TO CHANGES; NOTES ON CHANGES

(VISED)

them by revision F units according to paragraph 2 above.

It is important that the thrust be resisted by a method such as shown. The solenoid must not be supported at the nameplate end, as internal parts would deform from the pressure. Either pressure or impact may be used.

4. SPRING, latch lever return

a. Two defects have been found in the operation of the original spring used to bring the latch lever to the "out" position after release.

(1) One is an apparent weakness of the spring. This results in its inability to trip the next station switch at the end of the outward swing of the lever. The weakness is probably caused by a tendency of the long leg of the spring to creep partially out from under the lever, thus partly relieving the spring load.

(2) The other defect is a twisting of the loops of the spring so that the pawl (of the toggle) cannot clear between the loops. The pawl, by its incomplete movement, prevents the hooks from opening fully, and causes a hangup of the bomb.

b. To overcome these defects, the original torsion spring has been replaced by a compression spring under the latch lever switch actuator. The actuator has a welded button which retains the spring. The spot-welded hold-down clip provided for the original spring must be chiseled off to accommodate the new spring.

c. Note that the use of the new arrangement is not mandatory if the transfer switch is not used for relaying current to a succeeding station, and if the coils of the original spring bear firmly against the channel, providing clearance for the pawl as it swings down.

d. The making of this change is a factory operation. The description is given here so that racks requiring it and which can be spared, can be turned in for rework.

(See sketches on following sheet)

RESTRICTED

VII INDEX TO CHANGES; NOTES ON CHANGES

Y118 5,6

(SCALE 1/2)

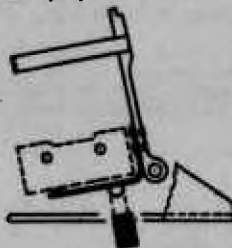

NEW TYPE SPRING

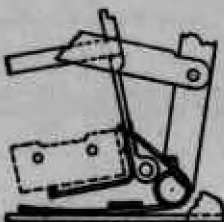

ORIGINAL TYPE SPRING SHOWING HOW PAWL MUST PASS BETWEEN THE COILS.



CHANGE IN LATCH LEVER RETURN SPRING (SEE PARA. 4)

5. WASHER, release solenoid backing

Because of occasional play between the release solenoid plunger and the latch lever, it is possible for the plunger to project from the face of the lever during manual release, so that the pawl stops on the edge of the plunger and the hooks fail to open.

To take up this play, a washer, shown at the right, is being placed on the plunger neck between the latch lever and the rubber cap. The latch lever should be disengaged from the solenoid plunger while the washer is being angled onto the neck of the latter.

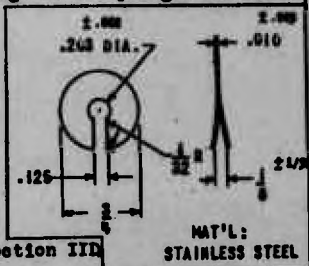

See also sketches, sheet 25, section IID

6. BUSHINGS: pawl-link pivot, bronze

The pivot working in the pierced holes in the stainless steel pawl at the point where the toggle breaks has been found to work stiffly when the holes are rough. Because this has been found to cause occasional hangups, the pawl is being fitted with bronze bushings, which, properly made, provide a low coefficient of friction.

To make this change, proceed as follows:

- a. Remove the hook & link assembly from the rack. (see IV)
- b. Knock rivet out which holds pawl to link.
- c. Enlarge the pawl holes according to sketch below.
- d. Make two bushings and one new rivet according to sketches below.

RESTRICTED

VII INDEX TO CHANGES; NOTES ON CHANGES

(VIIIR7)

e. Reassemble, peening the rivet evenly.

These instructions are given so that stations having facilities can increase the effectiveness of the subject racks. Stations without facilities should turn in racks which can be spared in order that this and the other improvements listed may be made.

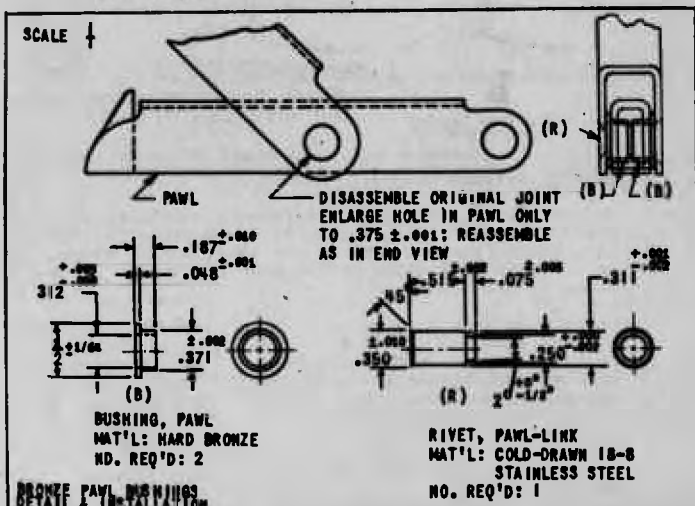

7. PLUNGER, manual arming (BuOrd 328766-5)

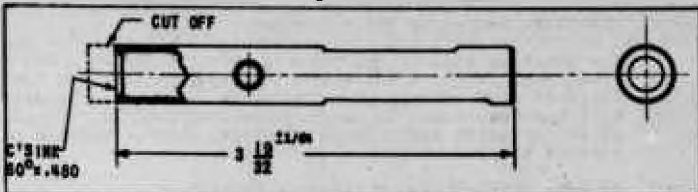

The cause of excessive force required to manually arm the rack has been found in some cases to be a misalignment between the brass grommet thru which the cable works, and the arming plunger. The misalignment causes a binding of the manual arming spring 328766-6, which is held in the plunger, and which terminates in the grommet.

RESTRICTED

VII INDEX TO CHANGES; NOTES ON CHANGES

To relieve the binding, the plunger is being reworked according to the sketch. Stations properly equipped may make this change.

Note that this change is only required if the manual cranking force is in excess of that given in the diagram on sheet 71, namely 12 lbs.

REEL - C

1748

A.T.I.

41379

TITLE: Aviation Ordnance Bomb Rack Mark 51 Mods. 6, 7, 8 and 9 (October 1944 Service Manual)

AUTHOR(S): Denzler, R.

ORIGINATING AGENCY: Pollak Manufacturing Co., Development Engineering Arlington,

PUBLISHED BY: Bureau of Ordnance, Washington, D. C.

(N. J.)

ATI- 41379

REVISION

(None)

ORIG. AGENCY NO.

OP -925 Change 1

PUBLISHING AGENCY NO.

(Same)

DATE	DOC. CLASS.	COUNTRY	LANGUAGE	PAGES	ILLUSTRATIONS
Dec '44		U.S.	Eng.	95	tables, diags, drwgs

ABSTRACT:

The service manual for operation and maintenance of the Mark 51 bombrack mods 6, 7, 8, and 9 is presented. The Mark 51 designates a 14-10. two hook bomb rack of stainless-steel construction. It is interchangeable with and replaces the Mark 35's, and has additional features. It is available in 12 and 24 volt DC modifications, and is designed for use with the Mark 6, 7, and 8 portable bomb holsts. The Mark 51 mods 6 and 7, made up for center hoisting, weighs 11-1/4 lb, and, when made up for left and right hoisting, 11-3/4 lb. The Mark 51's are designed to carry double fuzed bombs weighing from 25 to 1600 lb. The rack is serviceable after supporting 24,000 lb static downward load, equally divided between the hooks. Other design loads are: 12,800 lb upward; 17,300 lb at 30° forward of vertically down; and 12,000 lb aft; the last two loads being figured for a bomb center of gravity 7.5 in. below hook seats. The Mark 51 mods 8 and 9 replace, when available, the mods 6 and 7.

EO 12812 dd 6 NOV 1953

DISTRIBUTION: Copies of this report obtainable from Air Documents Division; Attn: MCDXD

DIVISION: Ordnance and Armament (22)

SECTION: Bombing Systems (8)

SUBJECT HEADINGS: Bomb racks (16674)

ATI SHEET NO.: R-22-8-21

Air Documents Division, Intelligence Department
Air Materiel Command

AIR TECHNICAL INDEX

Wright-Patterson Air Force Base
Dayton, Ohio