

RESTRICTED

Ordnance Pamphlet No. 898
(FIRST REVISION)

MINES

MINE IDENTIFICATION MANUAL

DESCRIPTION AND ILLUSTRATIONS OF MINES



OCTOBER 1943

*This publication is ~~RESTRICTED~~ and will be handled in accordance with
Article 76, United States Naval Regulations, 1920*

NATIONAL MARINE FISHERIES SERVICE EXTENSION DIVISION BULLETIN

EMERSON AVE. GLOUCESTER, MA. 01930

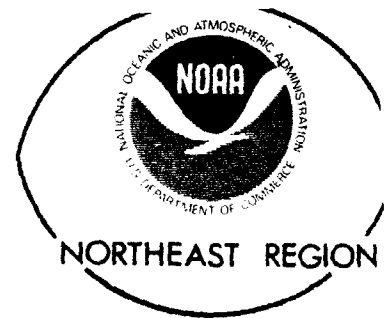

SAFE HANDLING OF EXPLOSIVES CAUGHT IN FISHING GEAR

FISHERMEN OPERATING OTTER TRAWLS, SCALLOP DREDGES AND OTHER FORMS OF BOTTOM TENDING GEAR ARE WARNED THAT BOTH EXPLOSIVE AND NON-EXPLOSIVE ORDNANCE MAY BE PRESENT ON FISHING GROUNDS ADJACENT TO THE U. S. COAST. RECORDS INDICATE THAT SNAGGING OF EXPLOSIVES IN FISHING GEAR IS OCCURRING WITH INCREASING FREQUENCY. MILITARY AUTHORITIES HAVE PROVIDED THE FOLLOWING INSTRUCTIONS FOR HANDLING EXPLOSIVE ORDNANCE OR ANY OBJECT NOT READILY IDENTIFIED AS A NON-EXPLOSIVE ITEM THAT MAY BE SNAGGED OR NETTED IN FISHING GEAR.

1. ANY OBJECT NOT READILY IDENTIFIED MUST BE TREATED AS AN EXPLOSIVE. DO NOT ATTEMPT TO BRING IT ON BOARD OR ALONGSIDE. RELEASE IT AND NOTIFY THE NEAREST COAST GUARD STATION GIVING YOUR POSITION AND DESCRIPTION OF THE OBJECT.
2. IF UNABLE TO RELEASE THE OBJECT STREAM IT AFT AS FAR AS POSSIBLE. KEEP CREW AT FORWARD END OF VESSEL AWAY FROM THE STERN. MAINTAIN STEERAGEWAY AS NECESSARY TO STAY IN AREA UNTIL INSTRUCTIONS ARE RECEIVED AND STANDBY FOR ASSISTANCE.

THE FOLLOWING ILLUSTRATIONS DEPICT THE EXPLOSIVES MOST LIKELY TO BE ENCOUNTERED.

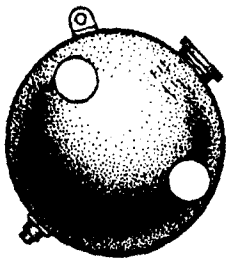

DIAMETER - 34"
WEIGHT - 480-510 #

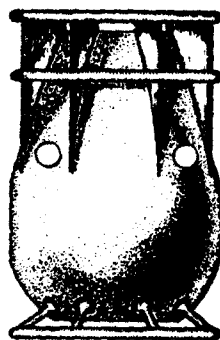

DIAMETER - 18"
LENGTH - 28"
WEIGHT - 250 #

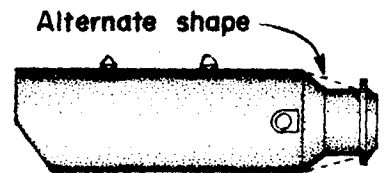

DIAMETER - 18"-23"
LENGTH - 5'-7"
WEIGHT - 1000-2000 #

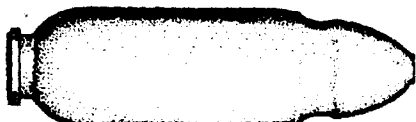

DIAMETER - 13"
LENGTH - 37"
WEIGHT - 60 #

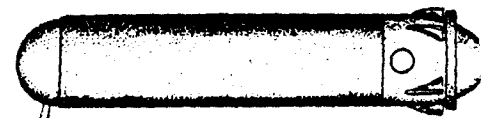

DIAMETER - 21"-23"
LENGTH - 9'-10'
WEIGHT - 2000 #

Alternate shape

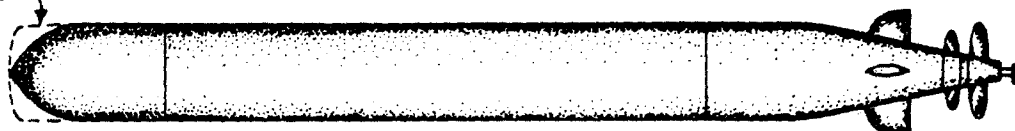

DIAMETER - 10"-21"
LENGTH - 8'-20'
WEIGHT - 400-4000 #

NAVY DEPARTMENT
BUREAU OF ORDNANCE
WASHINGTON, D. C.

OCTOBER 1943.

RESTRICTED

ORDNANCE PAMPHLET NO. 898 (FIRST REVISION).

MINE IDENTIFICATION MANUAL.

1. Ordnance Pamphlet Number 898, First Revision, contains outline drawings of all types of mines in general use.
2. It is intended that this publication be given wide distribution to forces ashore and afloat for the purpose of identifying mines which may be encountered and to facilitate reports thereon.
3. This publication supersedes such parts of Ordnance Pamphlet 814 (Mine Watch Manual) as pertain to identification of mines. Ordnance Pamphlet No. 898 dated October 1942 is hereby superseded and should be destroyed upon receipt of Ordnance Pamphlet No. 898, First Revision.
4. This publication is restricted and should be handled in accordance with the provisions of Article 76, U. S. Navy Regulations, 1920.

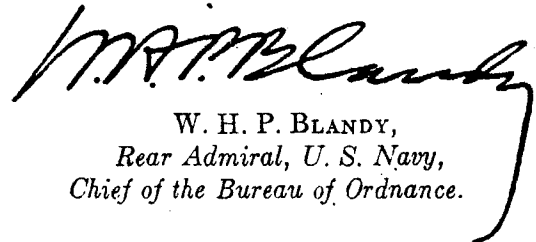
W. H. P. BLANDY,
Rear Admiral, U. S. Navy,
Chief of the Bureau of Ordnance.

MINE IDENTIFICATION MANUAL

TYPES OF MINES

1. Present-day mines may be divided into two general classifications—"controlled" and "independent." Controlled mines are mines which are controlled (fired) by an observer from a safe observation point. Independent mines are mines with self-contained firing mechanisms which function automatically. Independent mines may be subdivided as "contact" and "noncontact" or "influence" mines. In the former, the firing mechanism requires that an extending "horn" be moved or bent or that a wire "antenna" or some part of the mine be touched for the mine to fire. In the latter, the mere existence of metal, sound, or other disturbing influence in the vicinity of the mine may be all that is necessary to cause it to fire. The external appearance of a mine will not, in many cases, indicate the type firing mechanism used.

2. Independent mines may be divided into three types, depending on their final position in the water. These are:

(a) **Drifting Mines.**—Mines which float on or just under the surface of the water.

(b) **Moored Mines.**—Mines which are held under the surface of the water by a chain or wire attached to a heavy weight or "anchor" which rests on the bottom.

(c) **Ground Mines.**—Mines which are heavier than water and rest on the bottom.

METHOD OF LAYING

3. All types of independent mines can be laid by aircraft, surface craft, and submarines. Controlled mines are laid by special surface layers.

IDENTIFICATION

4. The following points may be considered in identifying mines:

(a) **Color.**—Mines are normally painted black but may be other colors and are occasion-

ally camouflaged. This paint frequently wears off, exposing red paint underneath. Where mines have been in the water for a long time, heavy marine growth may completely cover the case and external fittings.

(b) **Size and Shape.**—Mines are usually spherical, spherical with a cylindrical section between the two halves, or cylindrical in shape, and vary in diameter from about 16 inches to 46 inches, and in length up to about 125 inches. There are, however, a number of mines of irregular shape which do not fall into any of the above classes.

(c) **External Fittings.**—Numerous fittings which are located in or extend from mine cases may be used for purposes of identification. These include:

(1) **Cover Plates.**—Either one or both ends of mine cases are usually covered by cover plates bolted to the mine case. These plates normally vary from one to two feet in diameter.

(2) **Horns.**—Approximately two-thirds of all mines have horns extending from the mine case. These horns vary in length from $\frac{1}{2}$ inch to over 1 foot, but are normally about 5 inches in length. The three most common types are a short copper spike, a long steel spike, and a thick lead horn. Where used, they vary in number from 3 to 11. Horns of mines which have broken adrift are frequently bent or entirely broken off.

(3) **Hydrostats.**—Many mines contain one or more devices located in holes in the mine case for operating mechanisms within the mine. These devices usually do not extend beyond the mine case.

(4) **Mooring Wires and Antennae.**—Most types of mines are connected to steel mooring wires or chains at one end. Several types have copper antenna wires (not over 100 feet in length) connected to the other end. These antennae are usually attached to steel floats (in most cases about 1 foot in diameter and $1\frac{1}{2}$ to 2 feet in length), painted black and occasionally

containing horns. Mine sweeping cables or normal wear may cause the float and any part or all of either mooring cable or antenna to be missing. Floats are frequently found by themselves, and as such are harmless.

5. In order to facilitate identification, the mines in this publication are arranged in the following order:

(a) Spherical mines.—

(1) *Without horns.*—Arranged in order of diameter with small mines first.

(2) *With horns.*—Arranged as above. Where two or more mines of same diameter are shown, the one with the fewest horns is shown first.

(b) Spherical with center section.—

(1) *Without horns.*—Arranged in order of diameter. Mines of same diameter are arranged in order of length.

(2) *With horns.*—Same as without horns.

(c) Mines with antennae and floats.—

(1) *Spherical mines.*—Arranged in order of diameter.

(2) *Spherical mines with center section.*—Same as (b) (1).

(d) Cylindrical and odd-shaped mines.—

Same as (b) (1). Where a mine of a given type may be of more than one size, it is located by the smallest size.

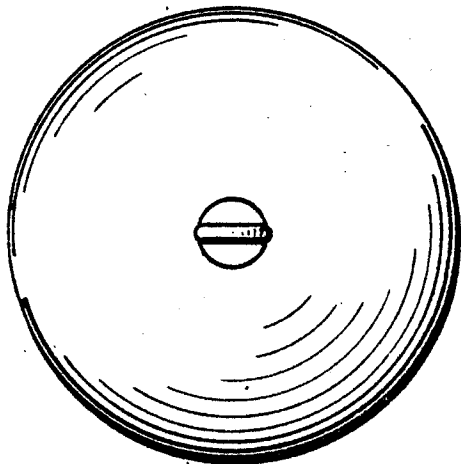

TOP VIEW

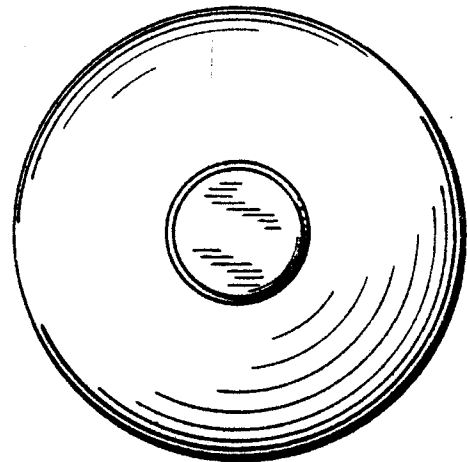

BOTTOM VIEW

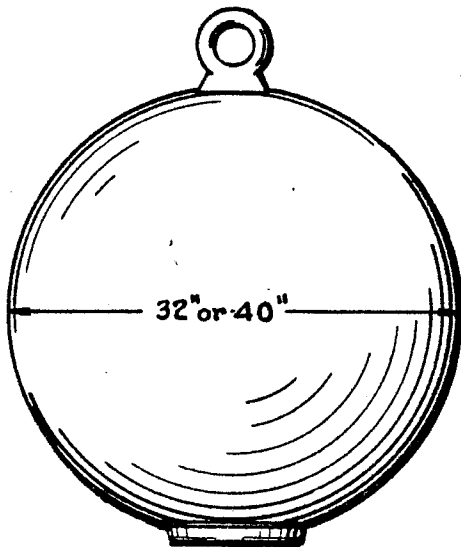

SIDE VIEW

TYPE-121

NO HORNS

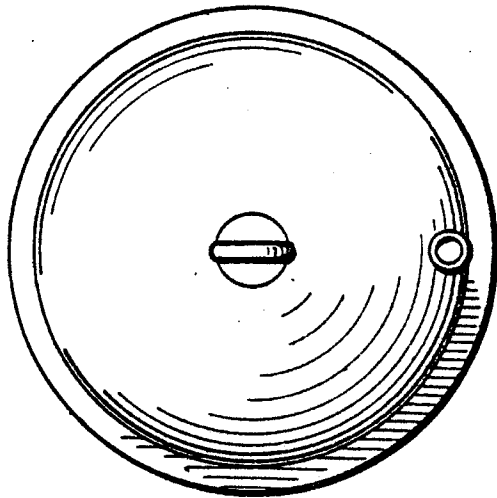

TOP VIEW

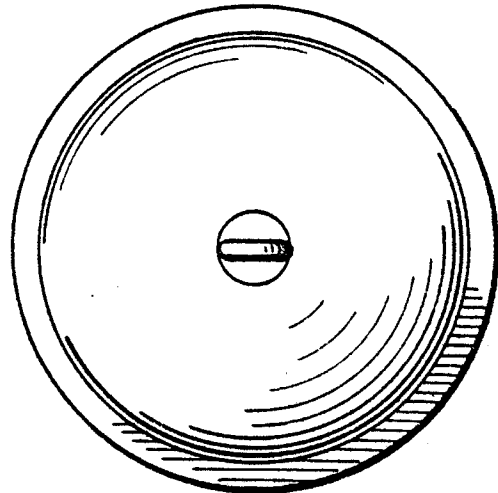

BOTTOM VIEW

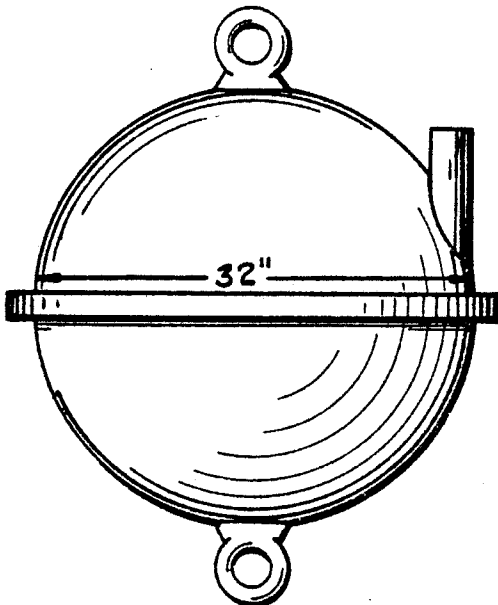

SIDE VIEW

TYPE-125

NO HORNS

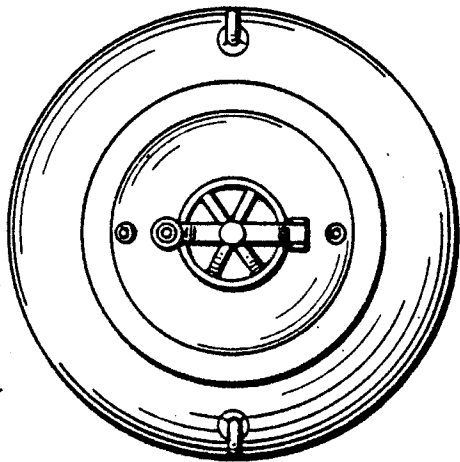

TOP VIEW

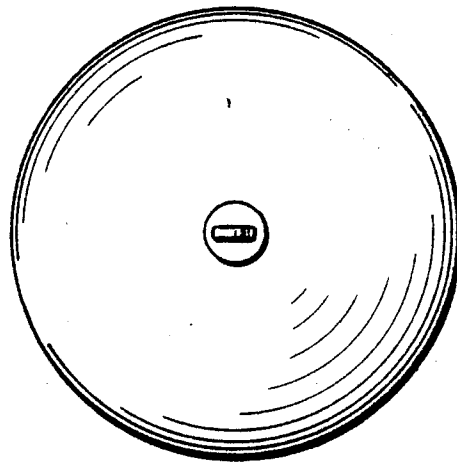

BOTTOM VIEW

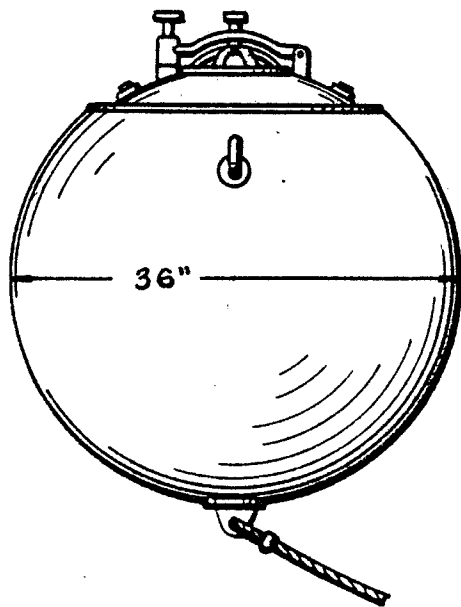

SIDE VIEW

TYPE-31

NO HORNS

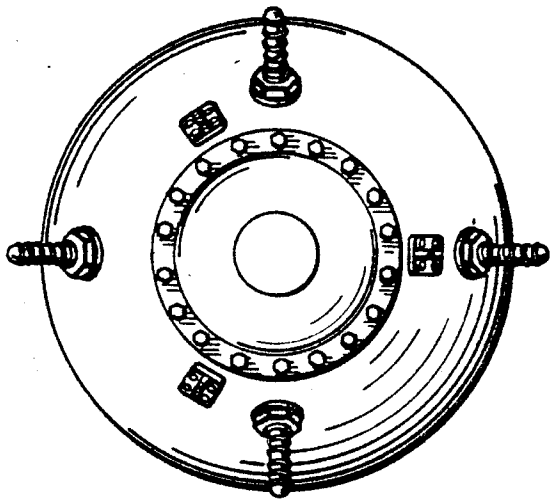

TOP VIEW

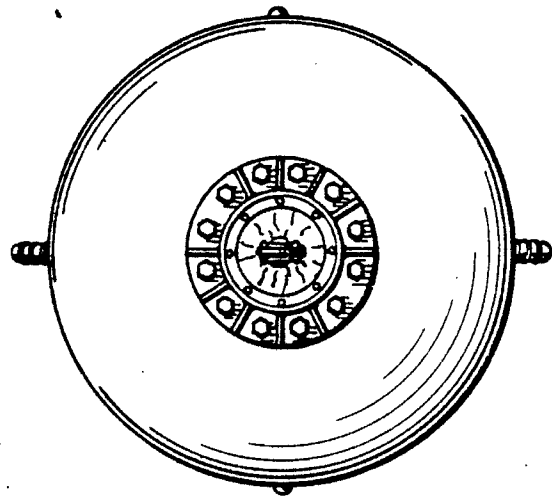

BOTTOM VIEW

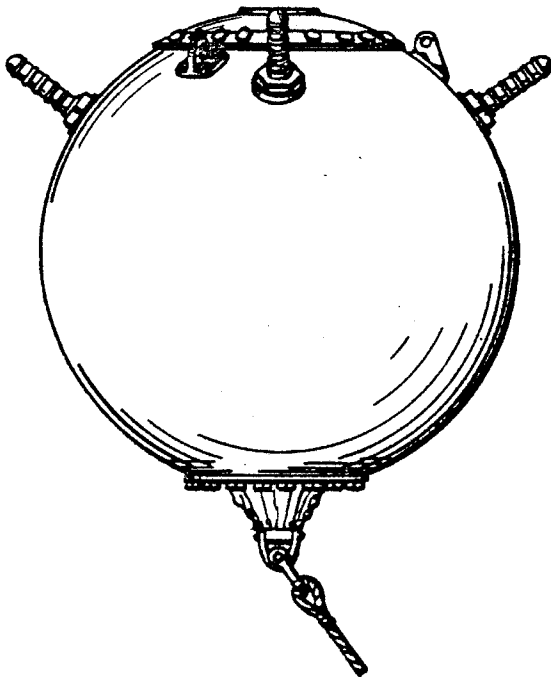

SIDE VIEW

TYPE-140

4-LEAD HORNS

DIMENSIONS NOT KNOWN

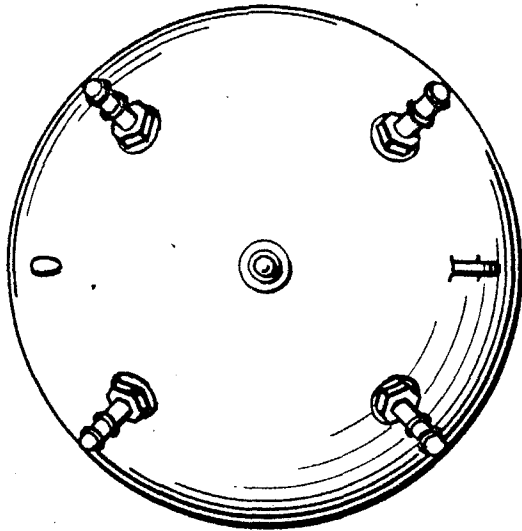

TOP VIEW

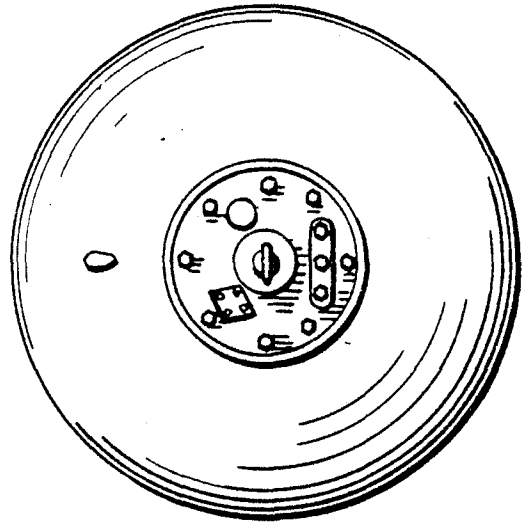

BOTTOM VIEW

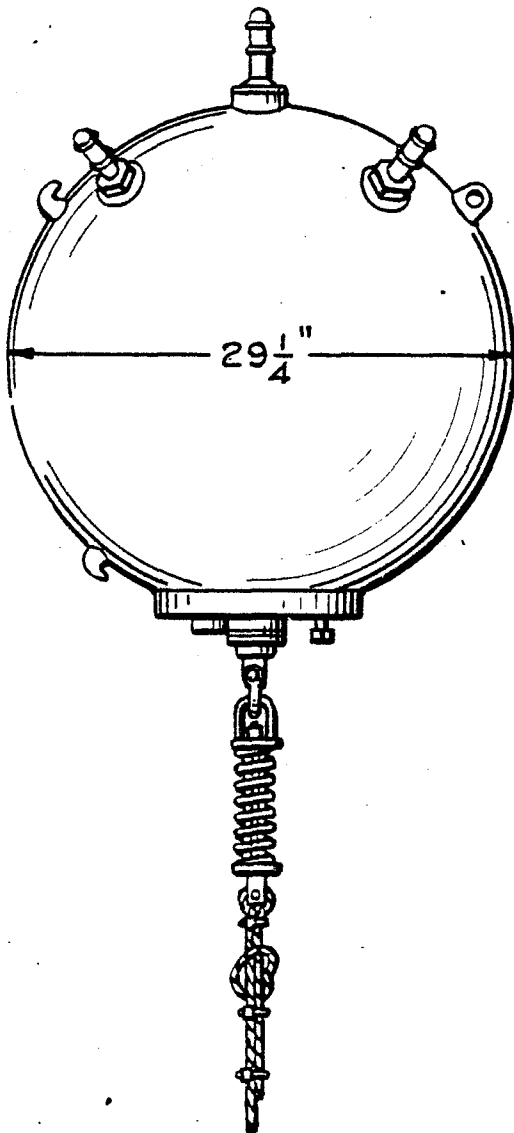

SIDE VIEW

TYPE-90
5-LEAD HORNS

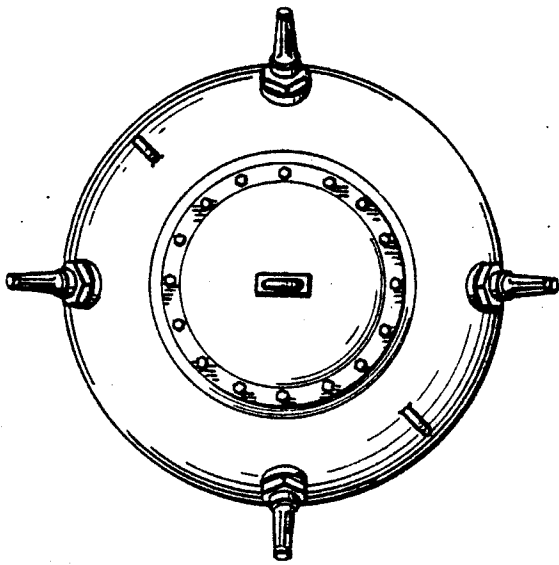

TOP VIEW

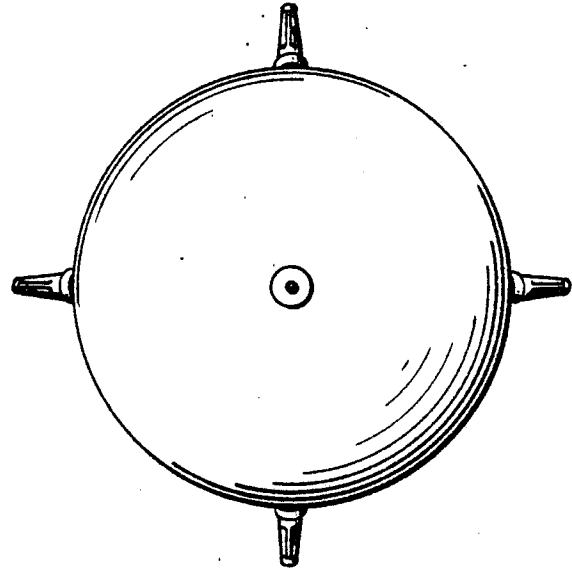

BOTTOM VIEW

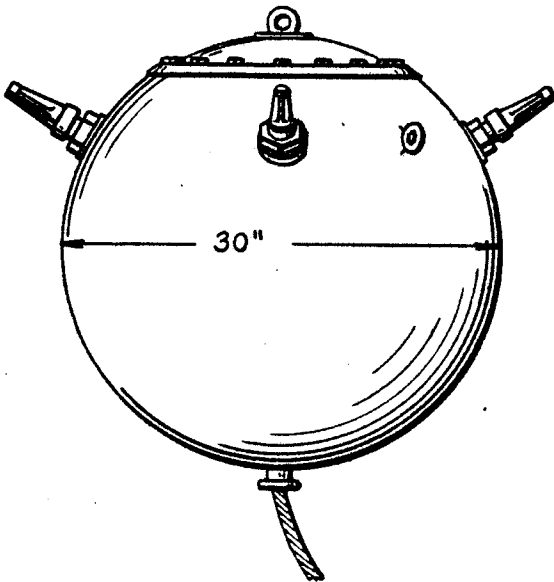

SIDE VIEW

TYPE-45

4-HORNS

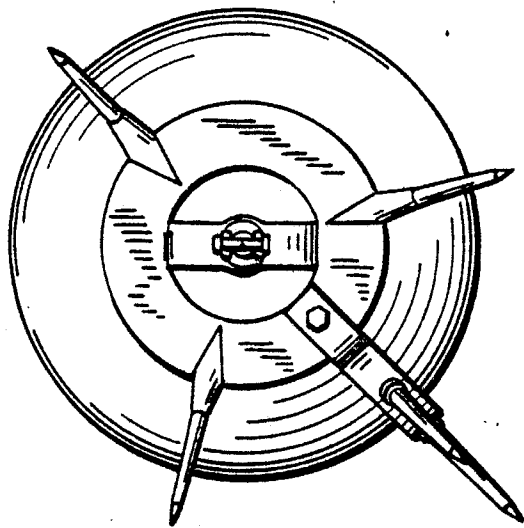

TOP VIEW

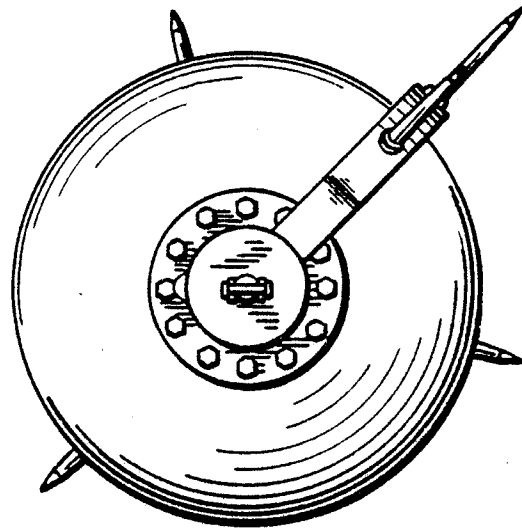

BOTTOM VIEW

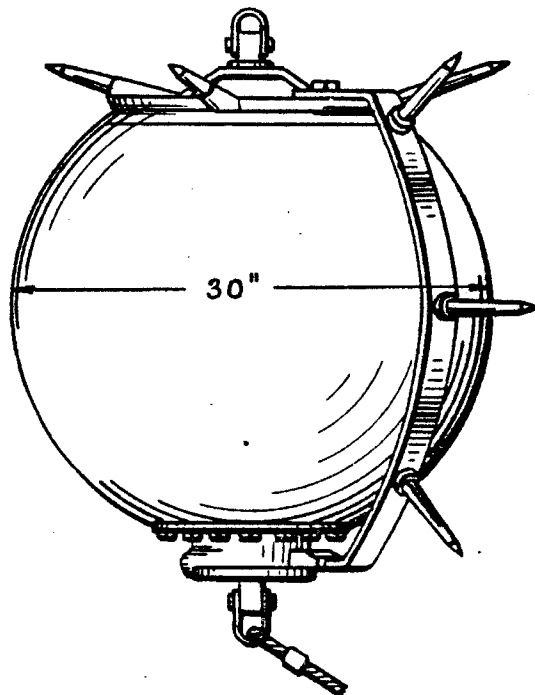

SIDE VIEW

TYPE-34

6 - SPIKE HORNS

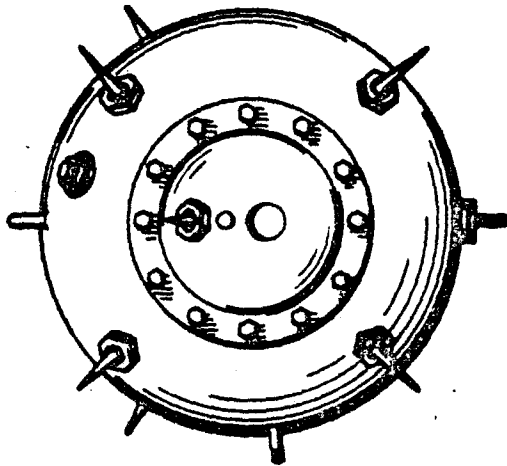

TOP VIEW

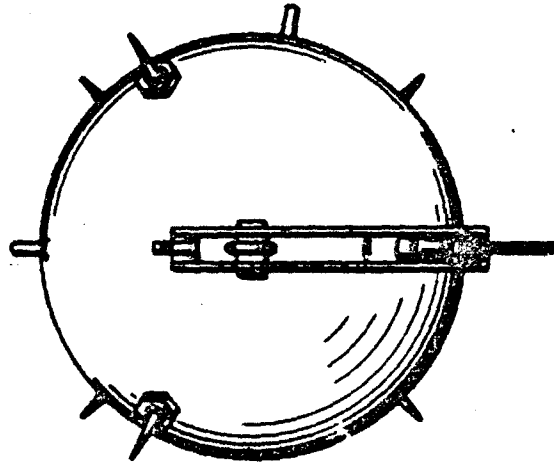

BOTTOM VIEW

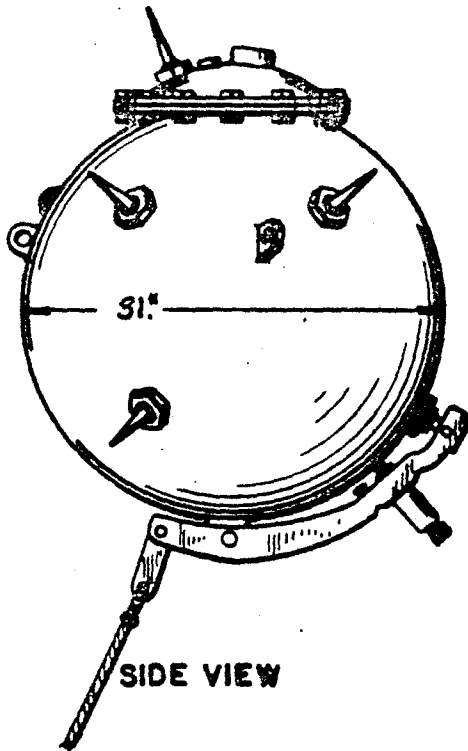

SIDE VIEW

TYPE-21

7-SPIKE HORNS

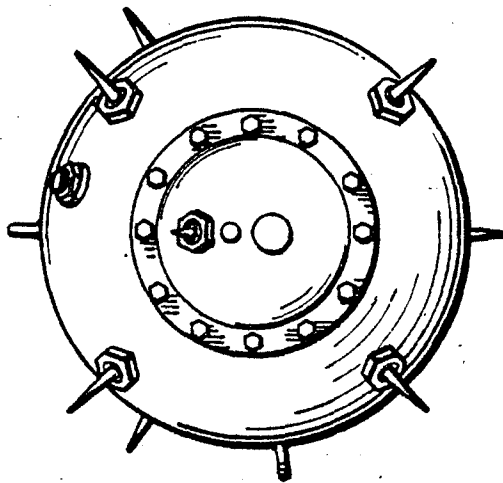

TOP VIEW

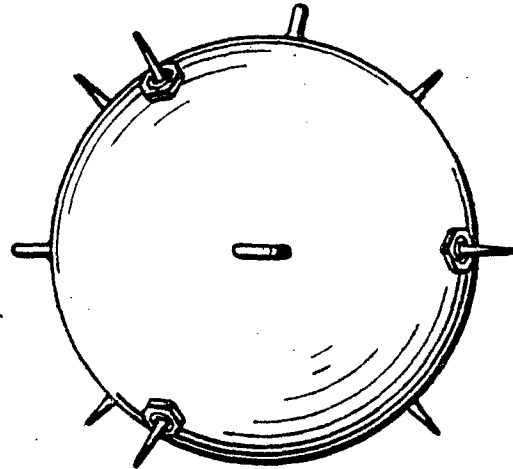

BOTTOM VIEW

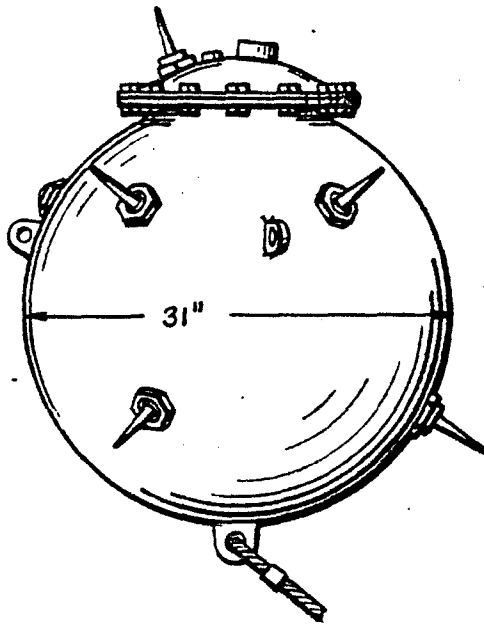

SIDE VIEW

TYPE-15

8-SPIKE HORNS

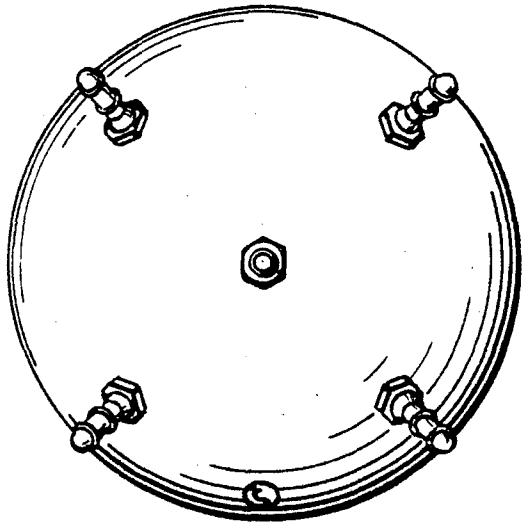

TOP VIEW

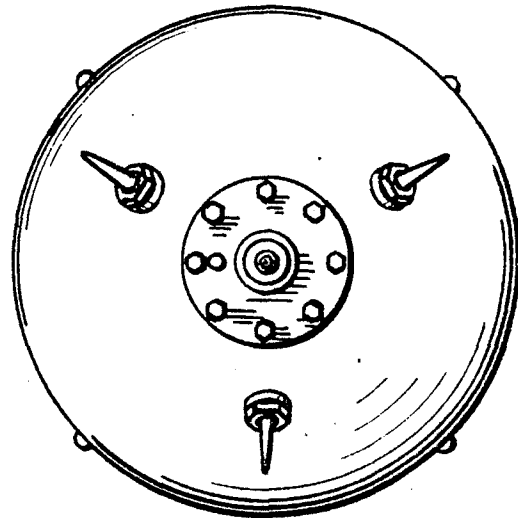

BOTTOM VIEW

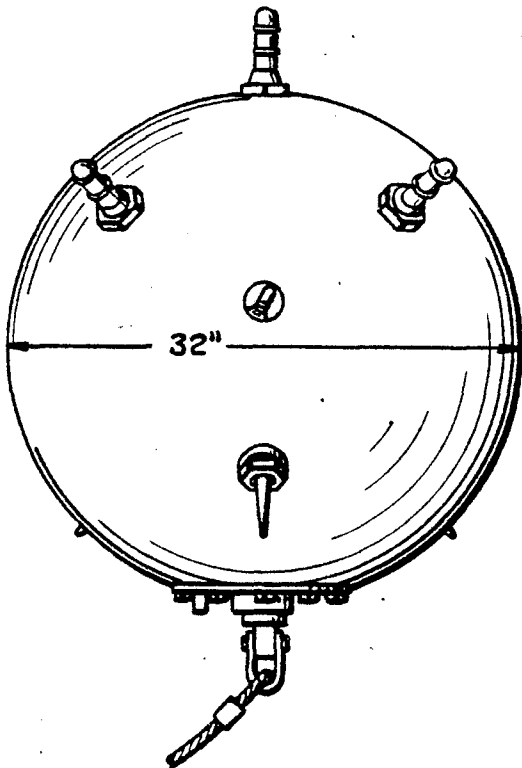

SIDE VIEW

TYPE-87

5-LEAD HORNS
3-SPIKE HORNS

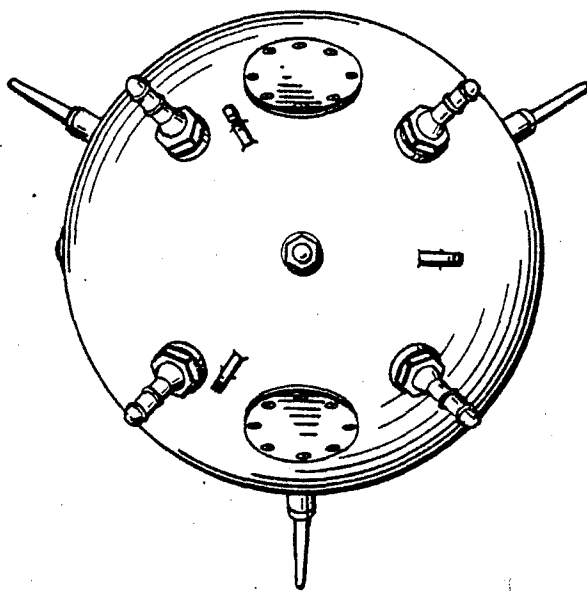

TOP VIEW

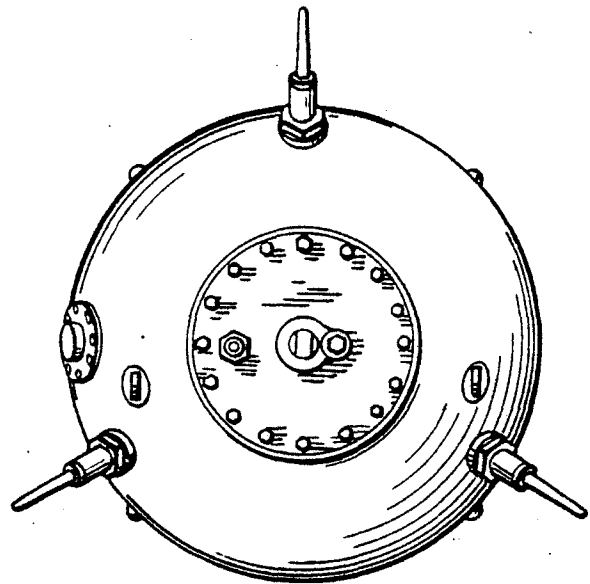

BOTTOM VIEW

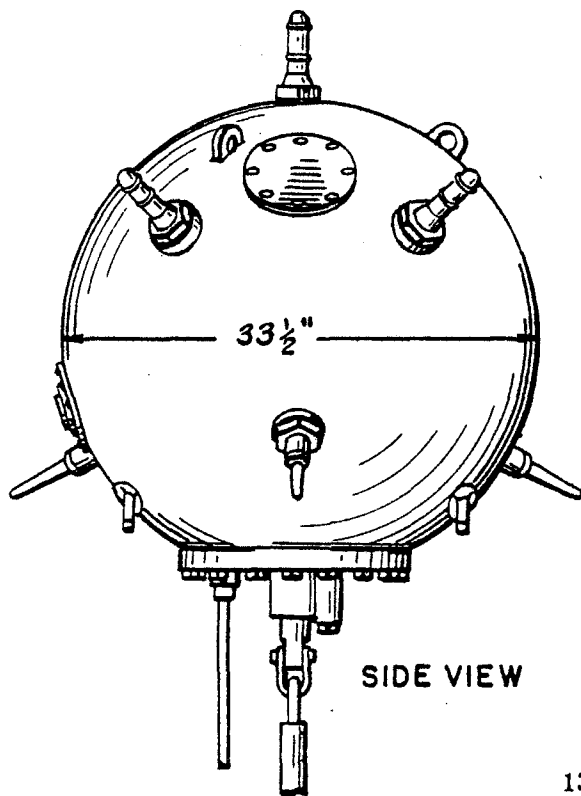

SIDE VIEW

TYPE-89

5-LEAD HORNS
3- SPIKES

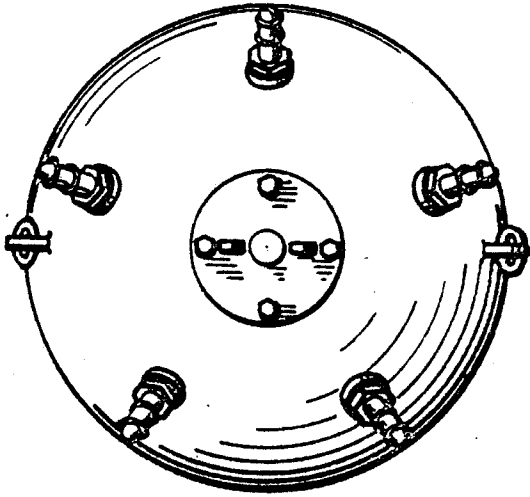

TOP VIEW

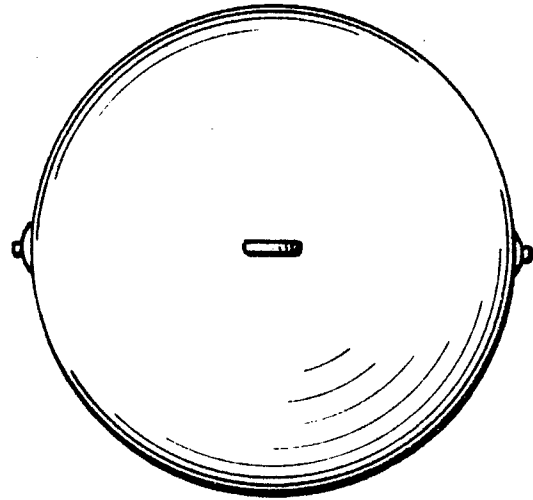

BOTTOM VIEW

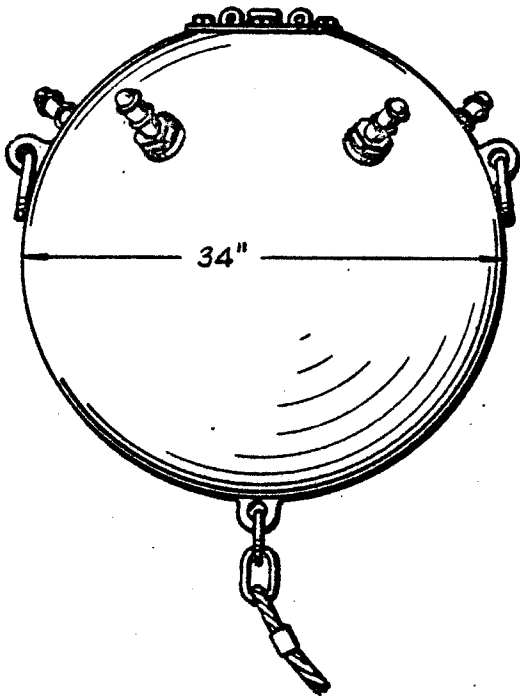

SIDE VIEW

TYPE-83

5-LEAD HORNS

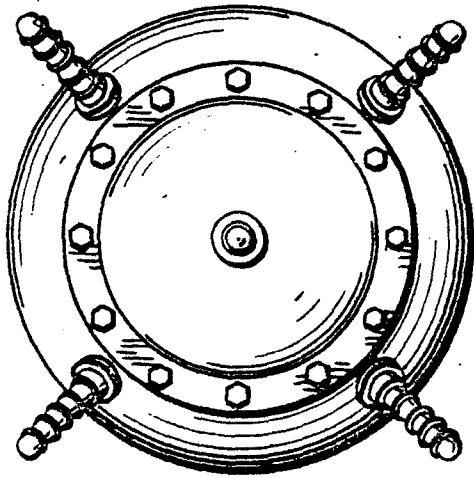

TOP VIEW

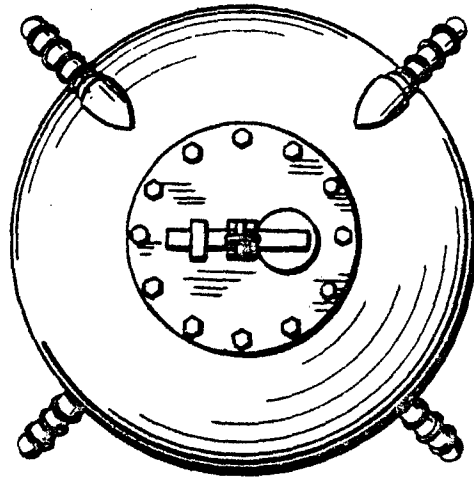

BOTTOM VIEW

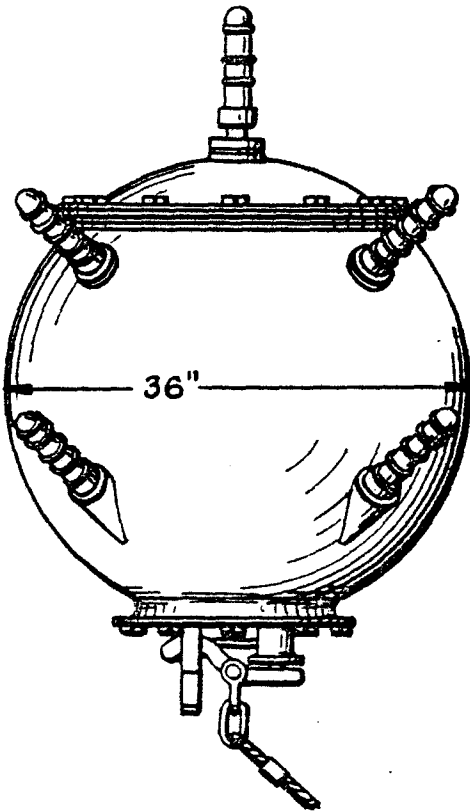

SIDE VIEW

TYPE-32
7-LEAD HORNS

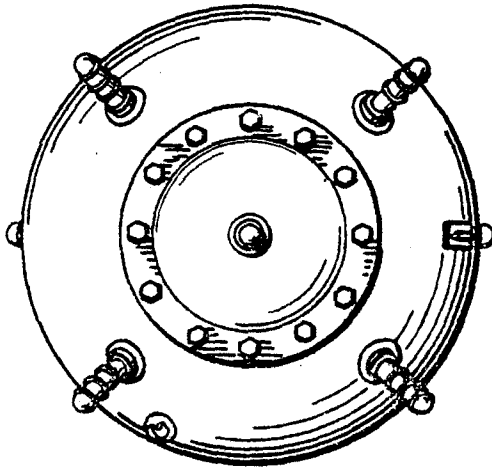

TOP VIEW

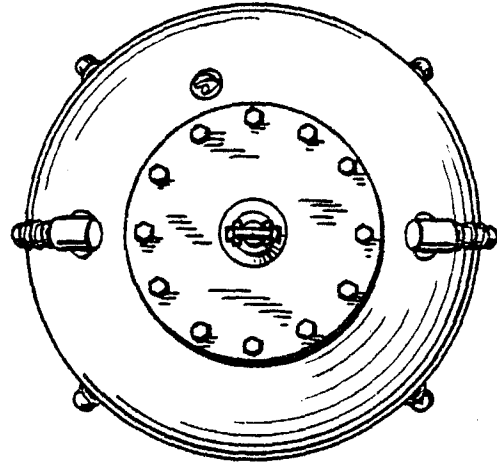

BOTTOM VIEW

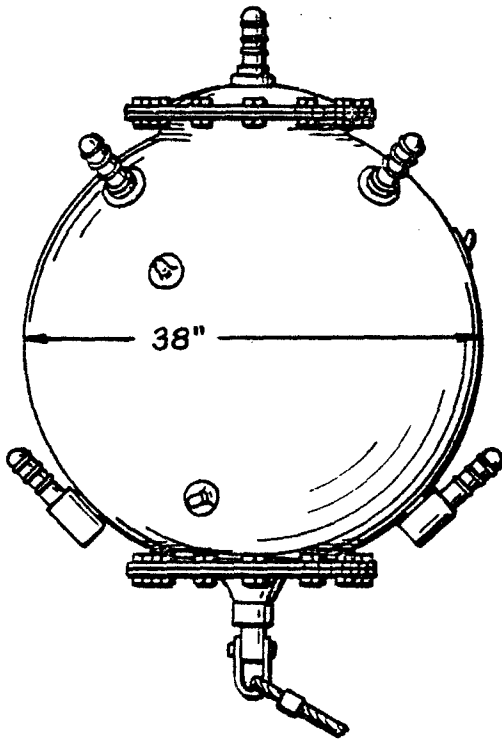

SIDE VIEW

TYPE-13

7-LEAD HORNS

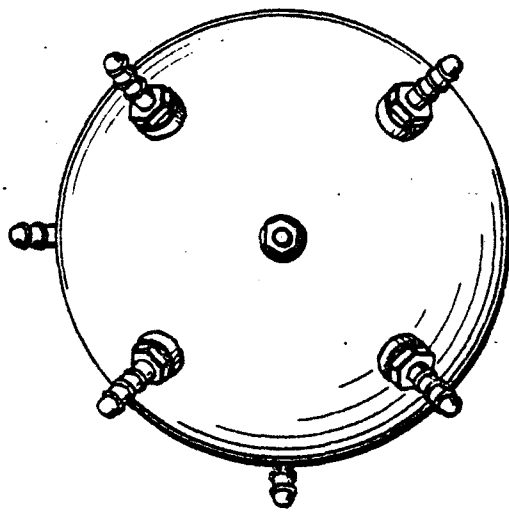

TOP VIEW

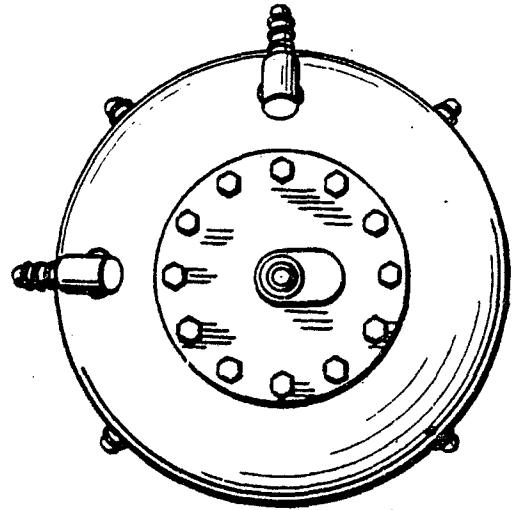

BOTTOM VIEW

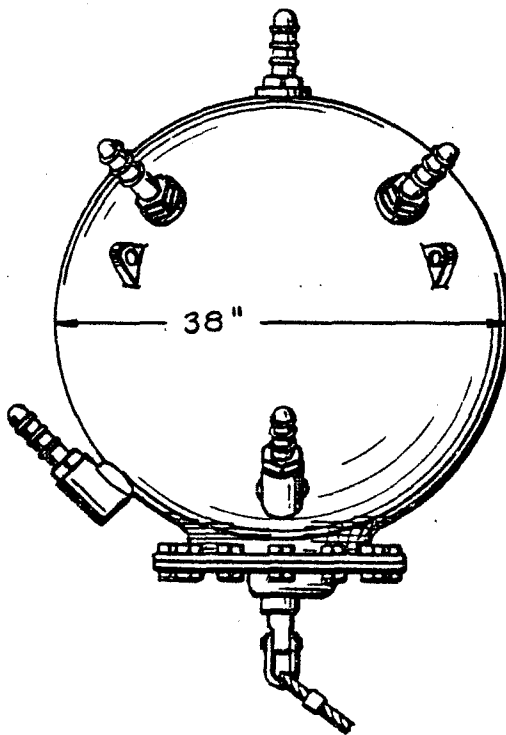

SIDE VIEW

TYPE-42

7-LEAD HORNS

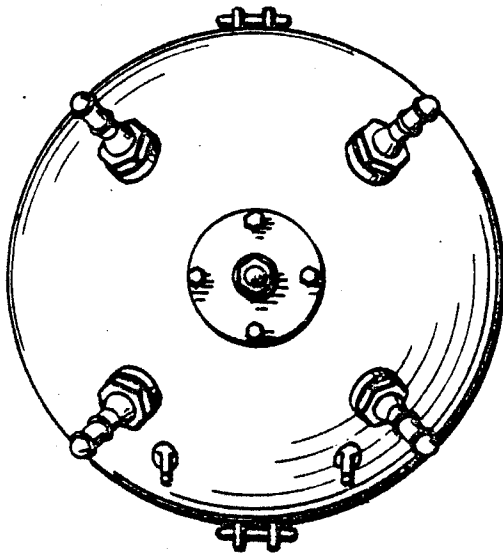

TOP VIEW

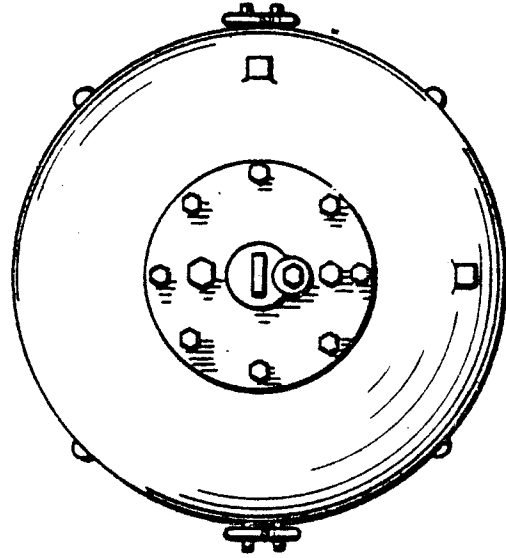

BOTTOM VIEW

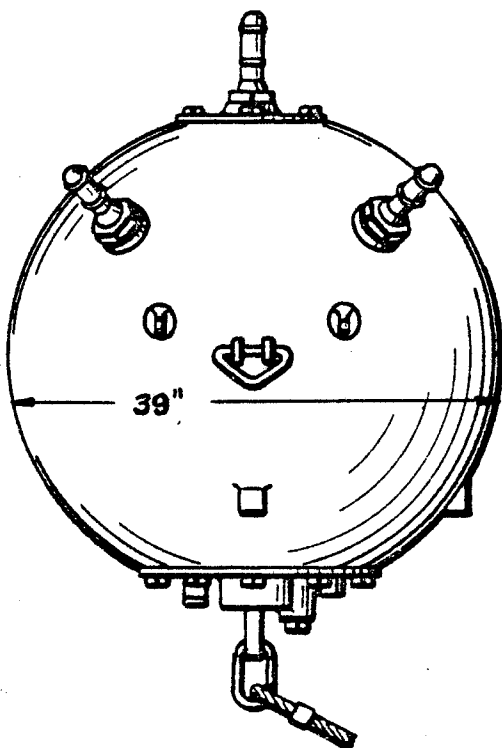

SIDE VIEW

TYPE-84

5-LEAD HORNS

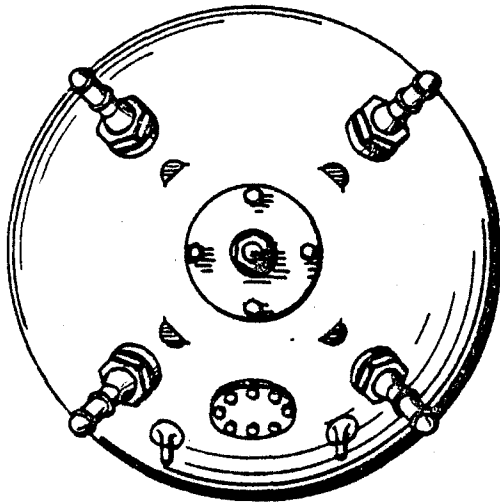

TOP VIEW

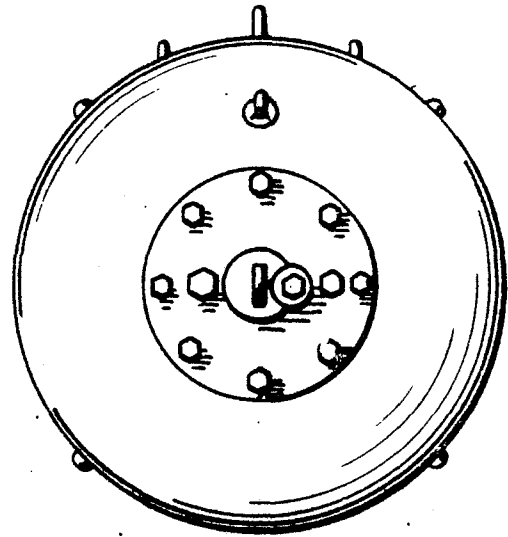

BOTTOM VIEW

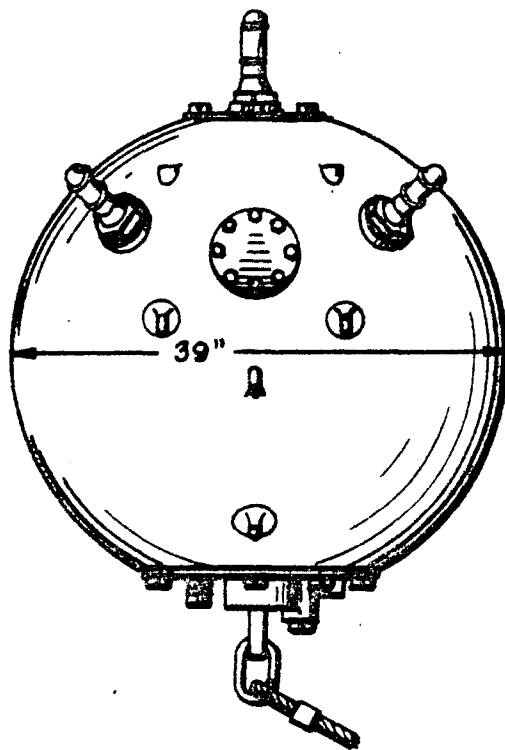

SIDE VIEW

TYPE-85

5-LEAD HORNS

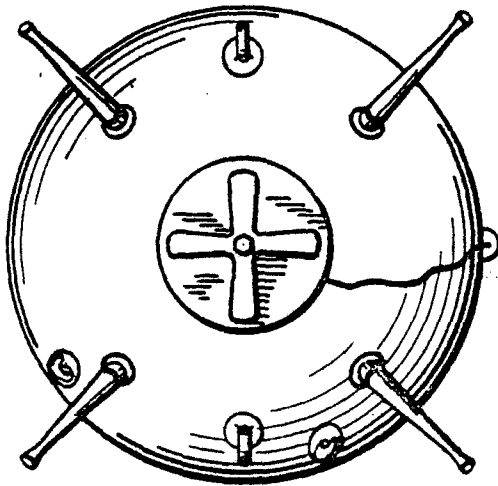

TOP VIEW

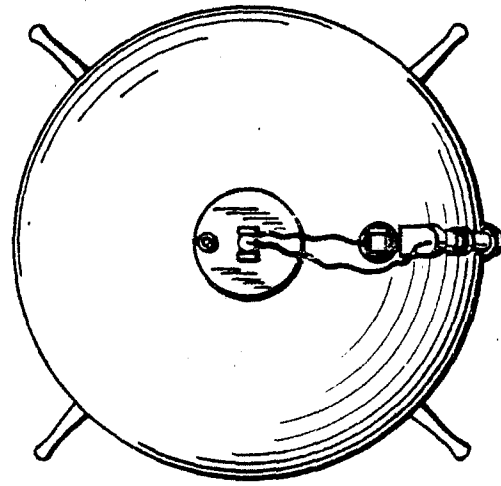

BOTTOM VIEW

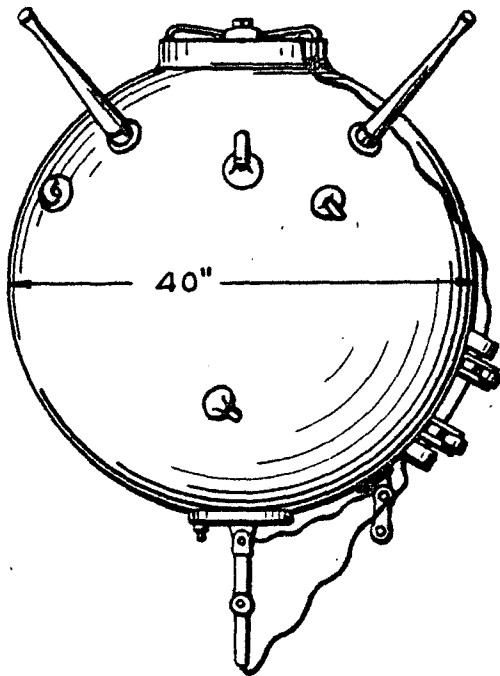

SIDE VIEW

TYPE-35

4-HORNS

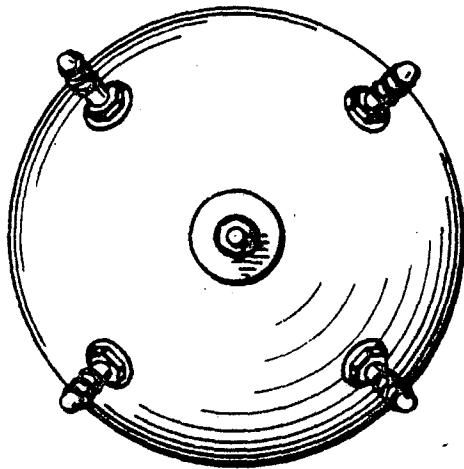

TOP VIEW

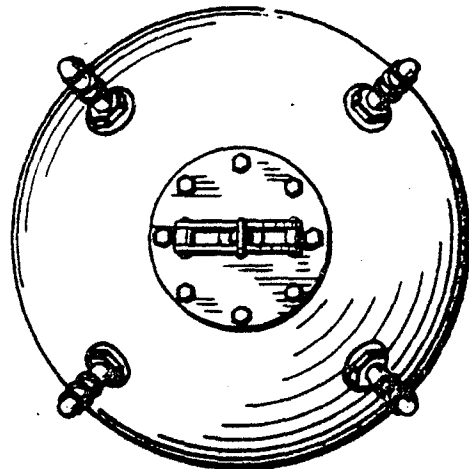

BOTTOM VIEW

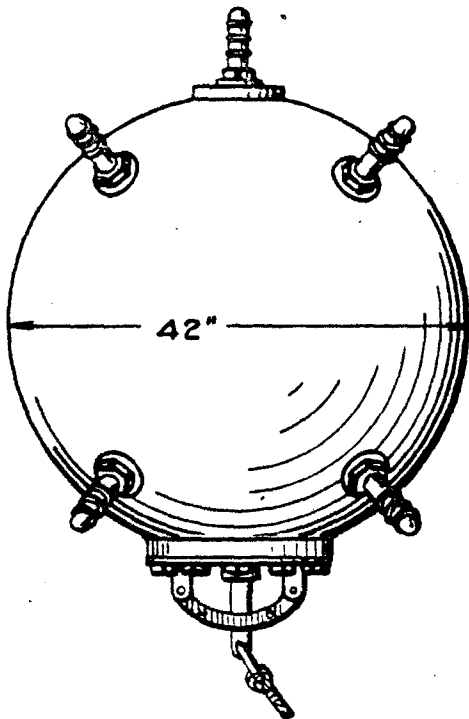

SIDE VIEW

TYPE-43

9-LEAD HORNS

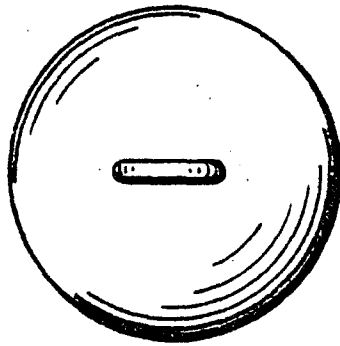

TOP VIEW

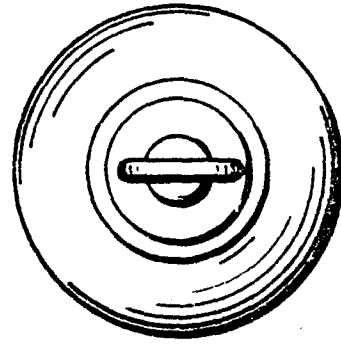

BOTTOM VIEW

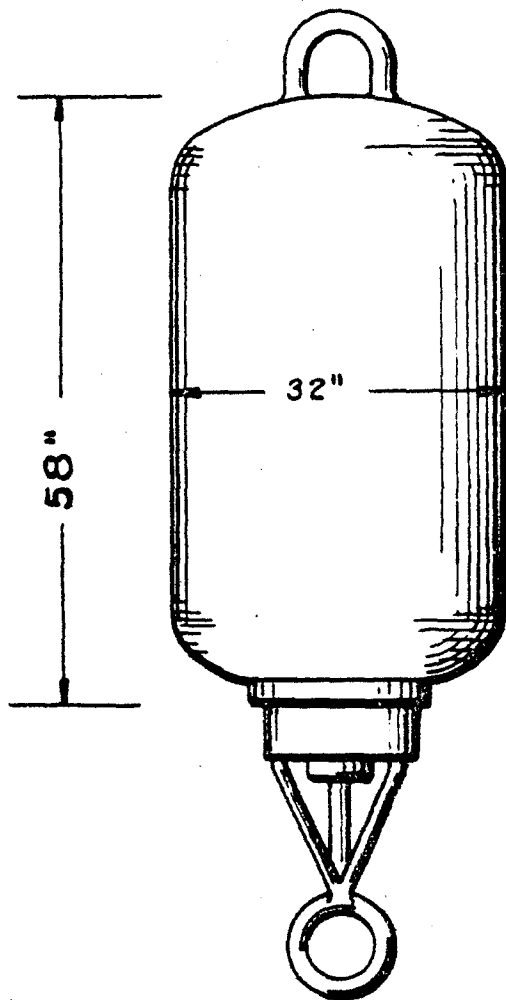

SIDE VIEW

TYPE-124

NO HORNS

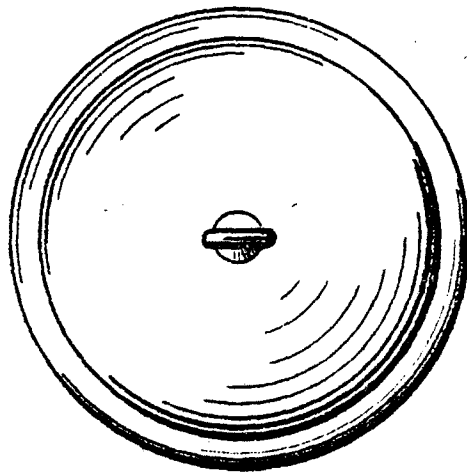

TOP VIEW

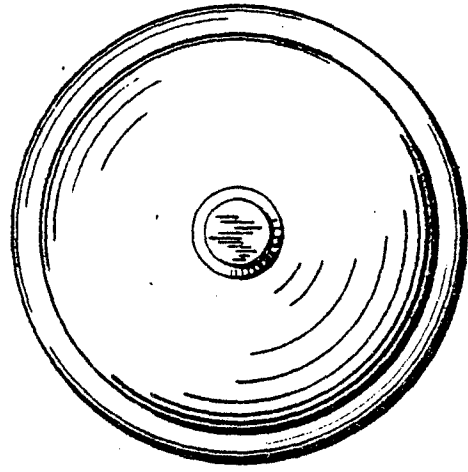

BOTTOM VIEW

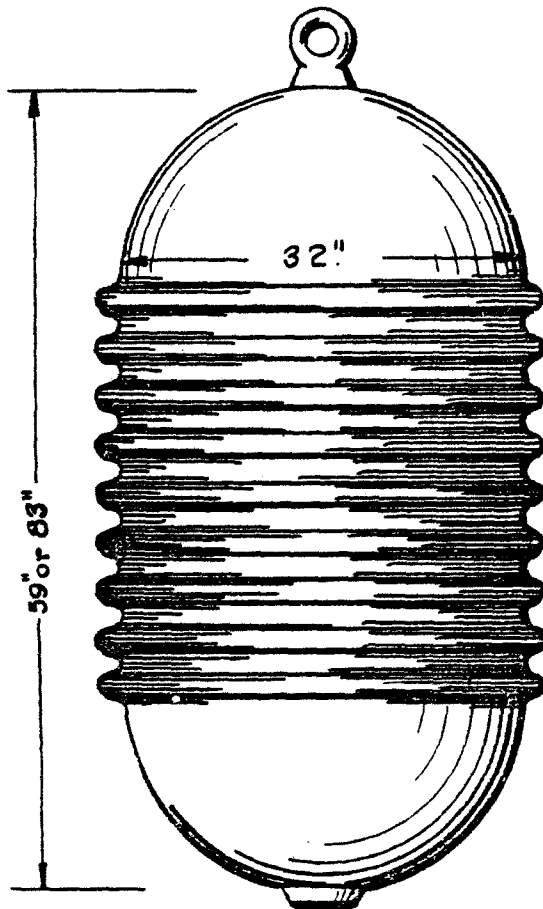

SIDE VIEW

TYPE-123

NO HORNS

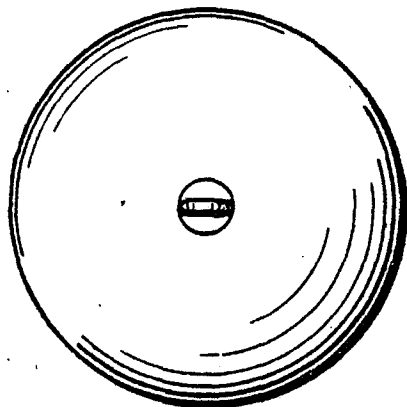

TOP VIEW

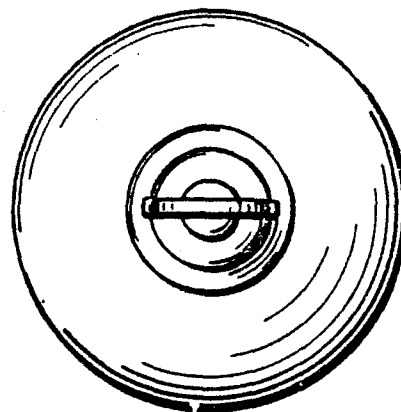

BOTTOM VIEW

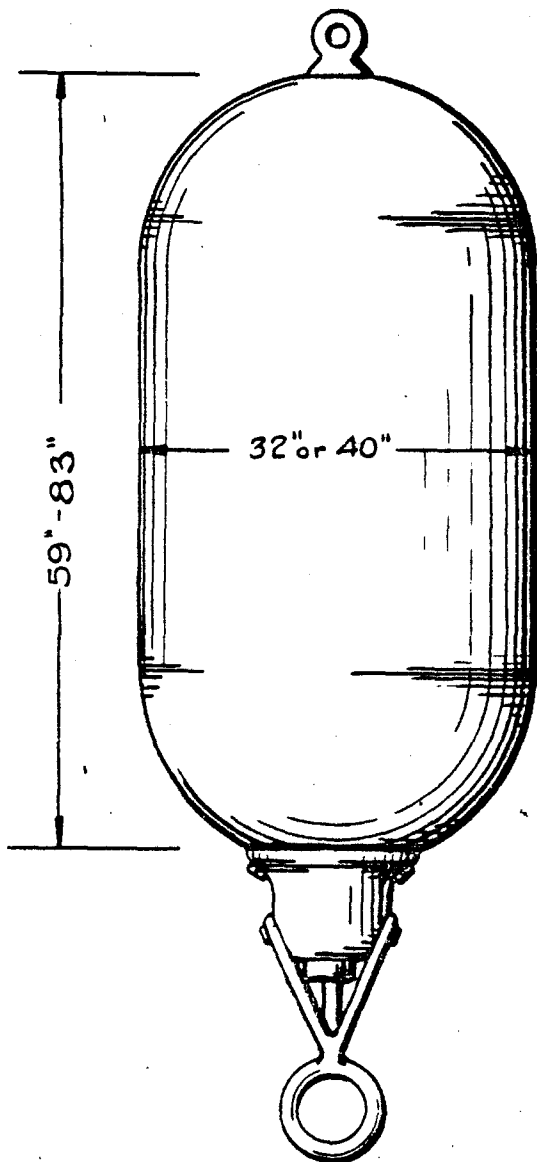

SIDE VIEW

TYPE-122

NO HORNS

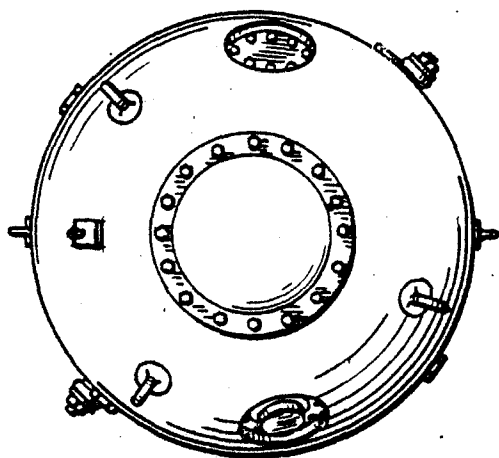

TOP VIEW

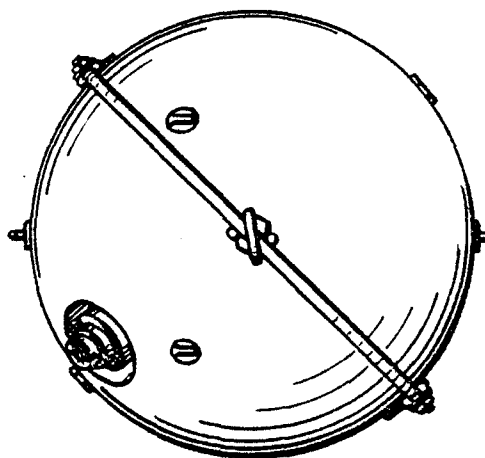

BOTTOM VIEW

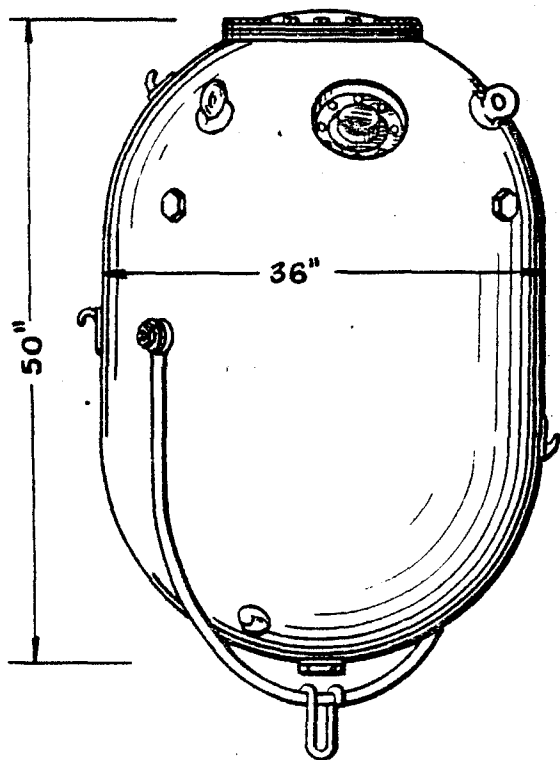

SIDE VIEW

TYPE-71

NO HORNS

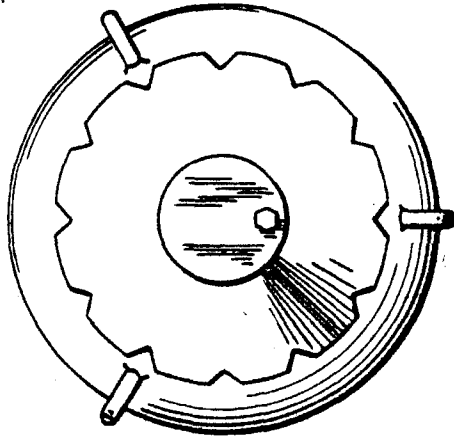

TOP VIEW

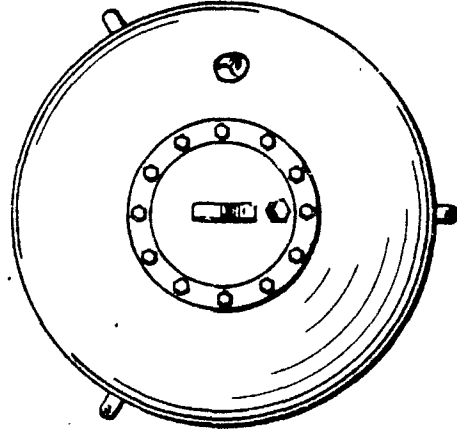

BOTTOM VIEW

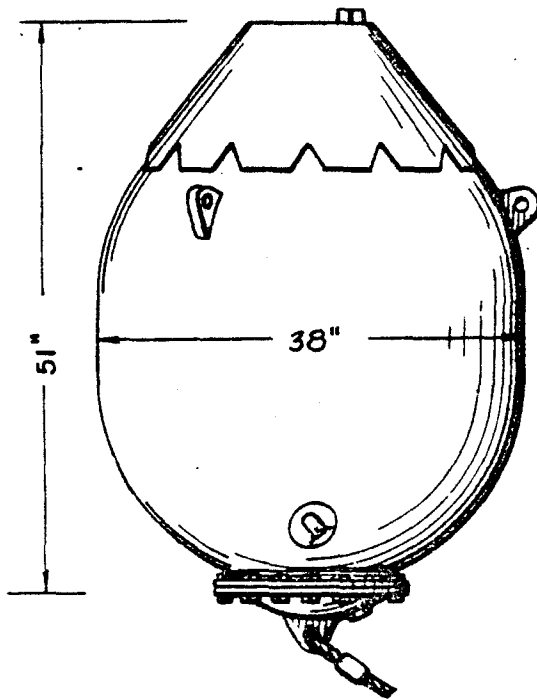

SIDE VIEW

TYPE-II

NO HORNS

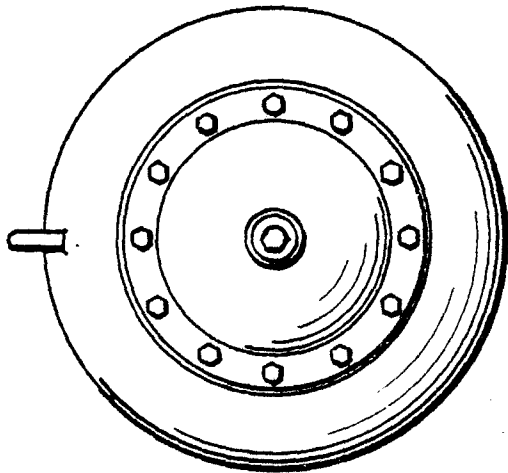

TOP VIEW

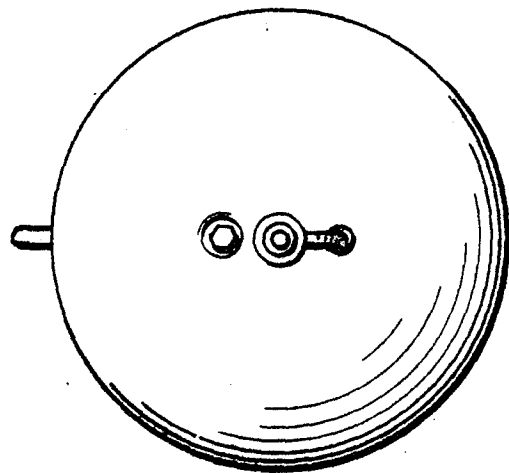

BOTTOM VIEW

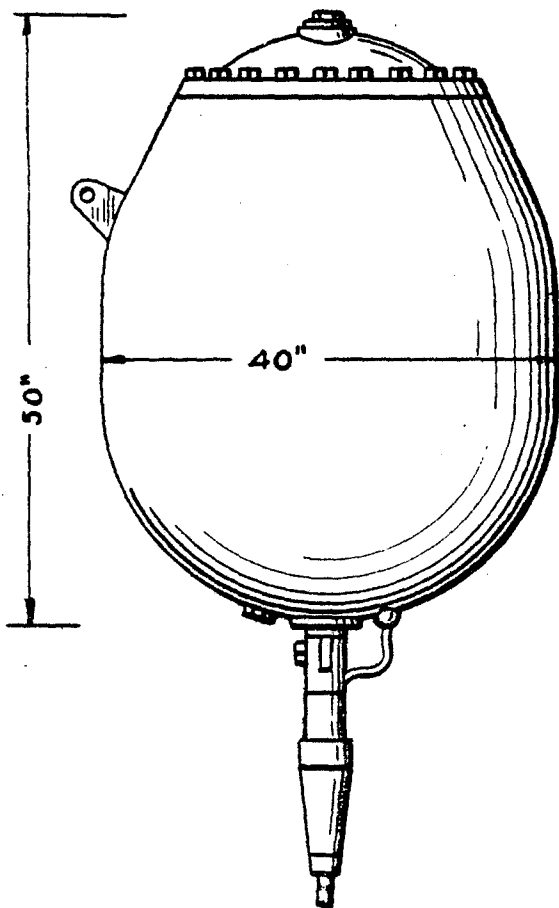

SIDE VIEW

TYPE-12

NO HORNS

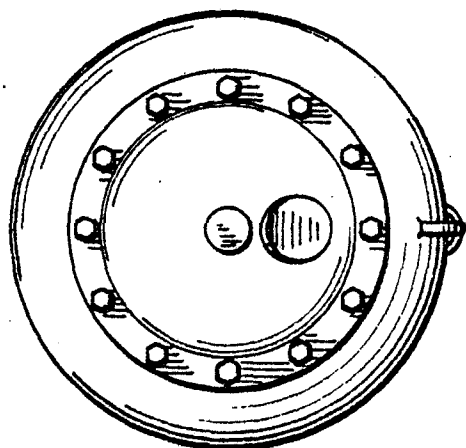

TOP VIEW

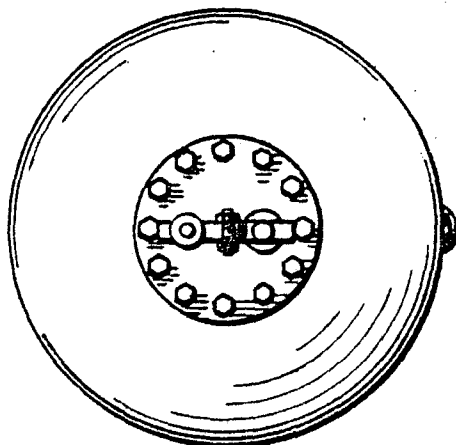

BOTTOM VIEW

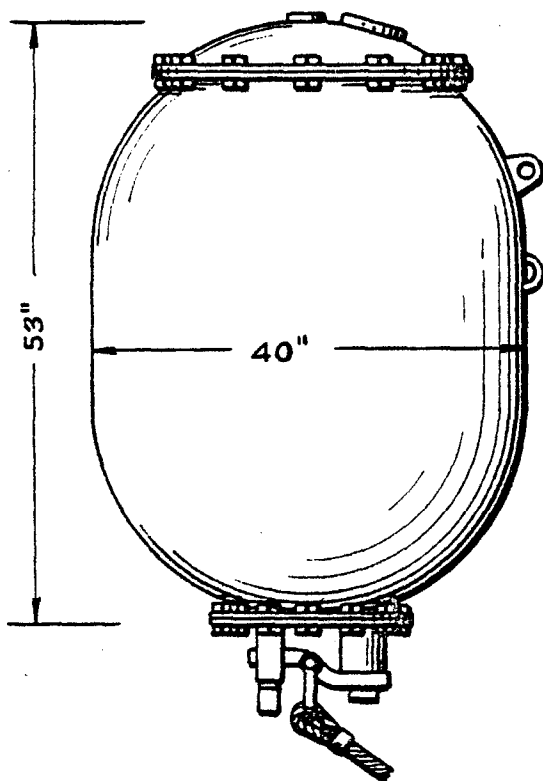

SIDE VIEW

TYPE-19

NO HORNS

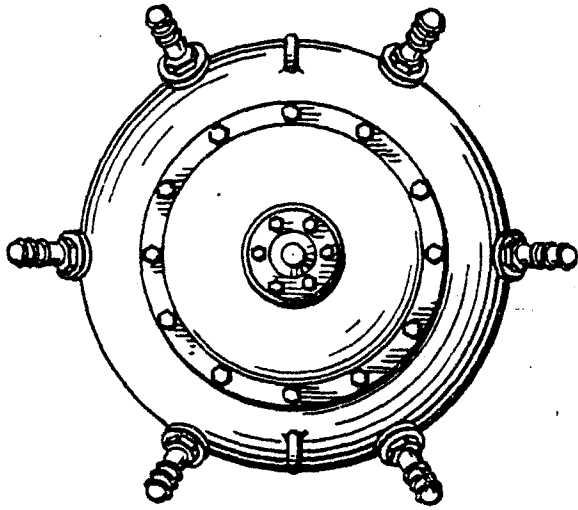

TOP VIEW

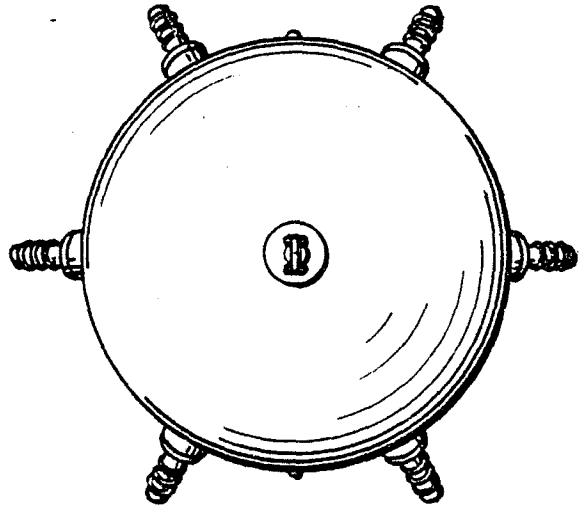

BOTTOM VIEW

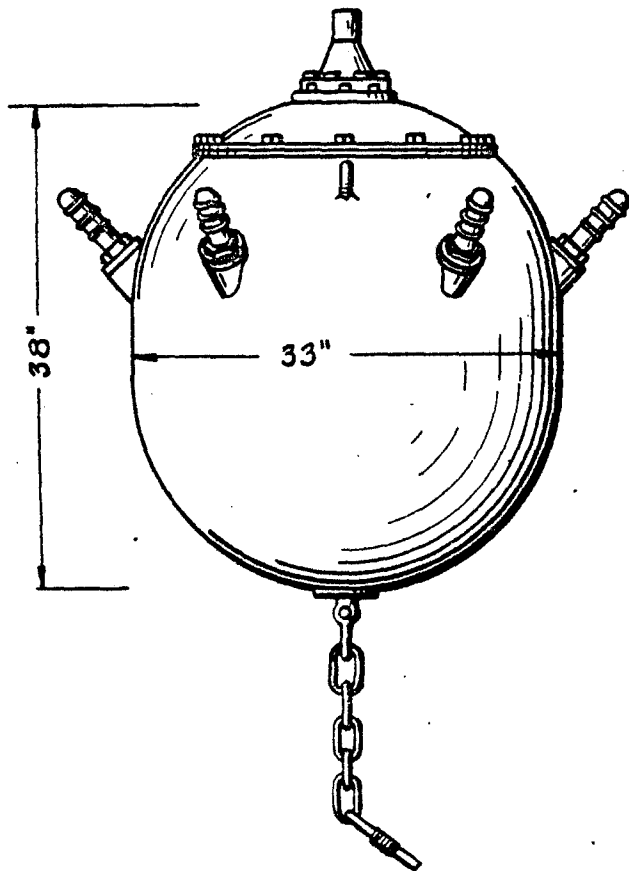

SIDE VIEW

TYPE-41
6-LEAD HORNS

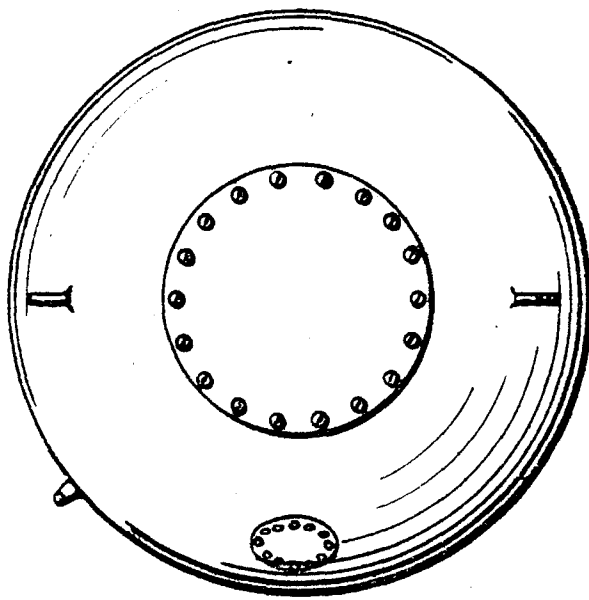

TOP VIEW

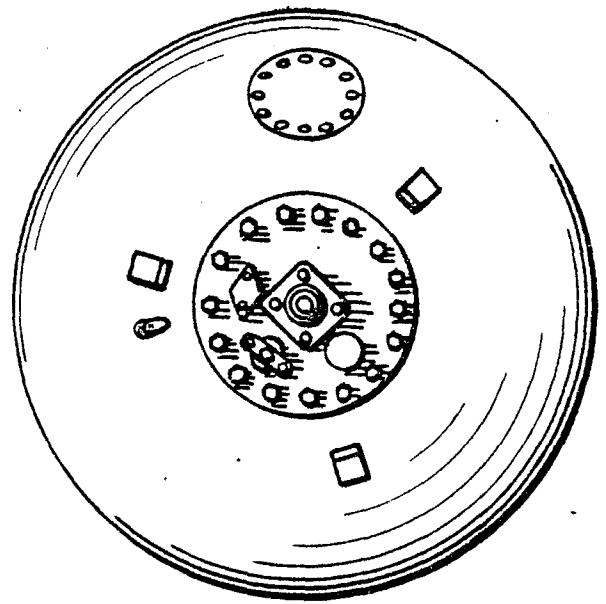

BOTTOM VIEW

TYPE-106

NO HORNS

VARIATIONS

- A-NO SIDE PLATES.
6 INCH BAND CONNECTING
UPPER AND LOWER HEMI-
SPHERES.
- B-NO LOWER SIDE PLATES
LIFTING LUGS 45 DEGREES
APART.
- C-6 INCH BAND CONNECTING
UPPER AND LOWER HEMI-
SPHERES — LIFTING LUGS
45 DEGREES APART.

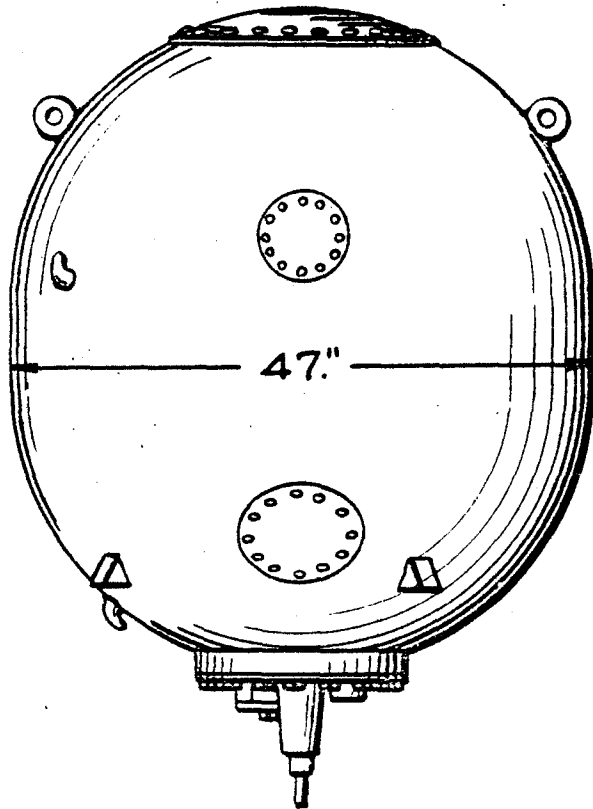

SIDE VIEW

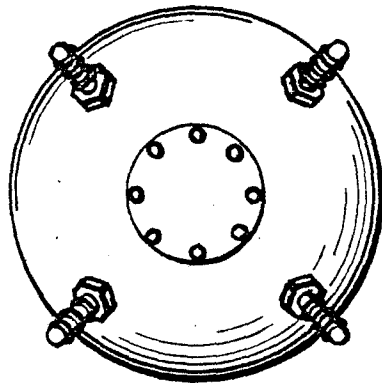

TOP VIEW

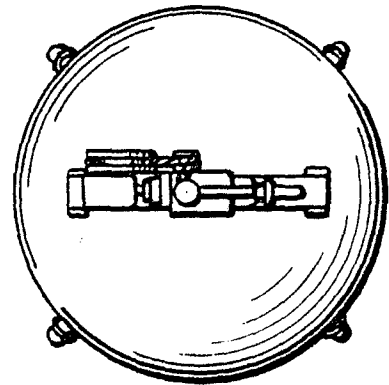

BOTTOM VIEW

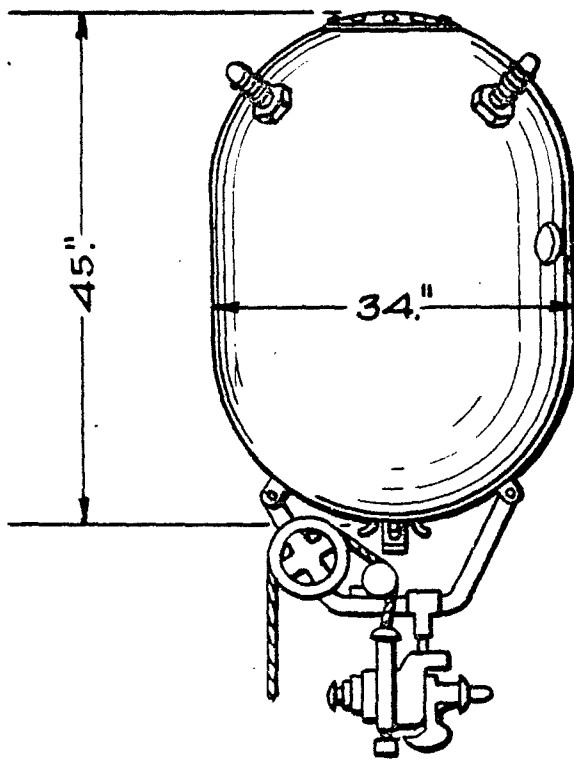

SIDE VIEW

TYPE-137

4-LEAD HORNS

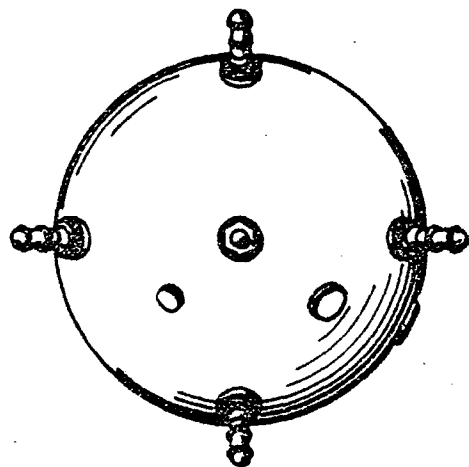

TOP VIEW

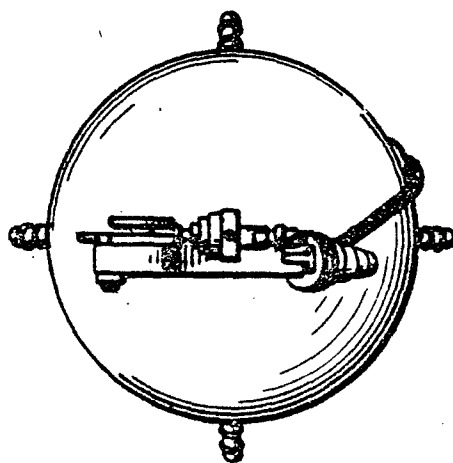

BOTTOM VIEW

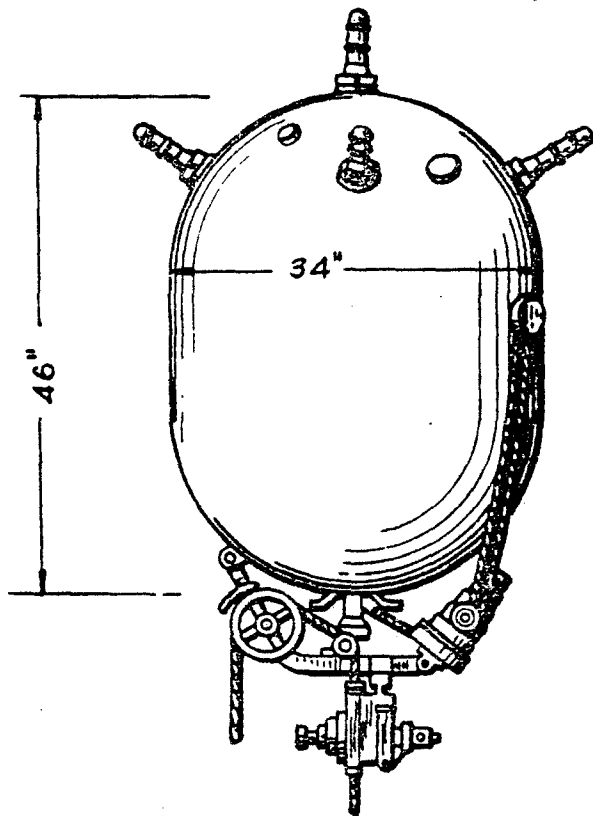

SIDE VIEW

TYPE-82

5-LEAD HORNS

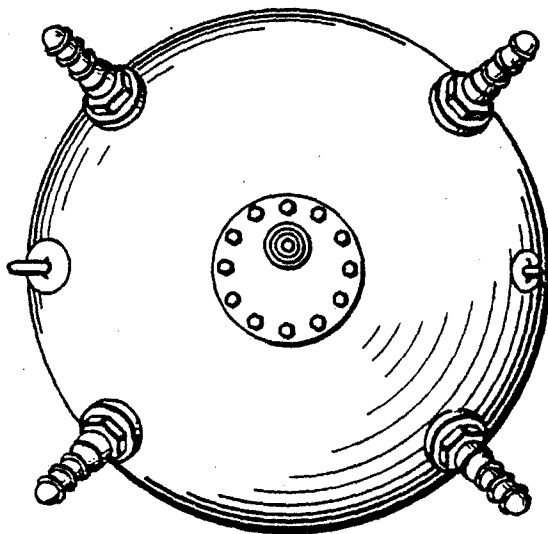

TOP VIEW

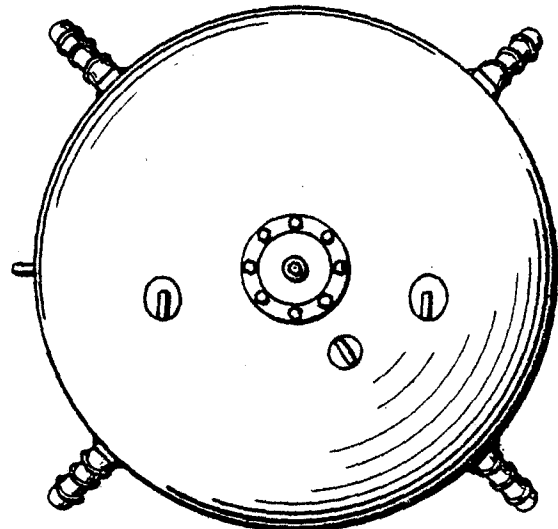

BOTTOM VIEW

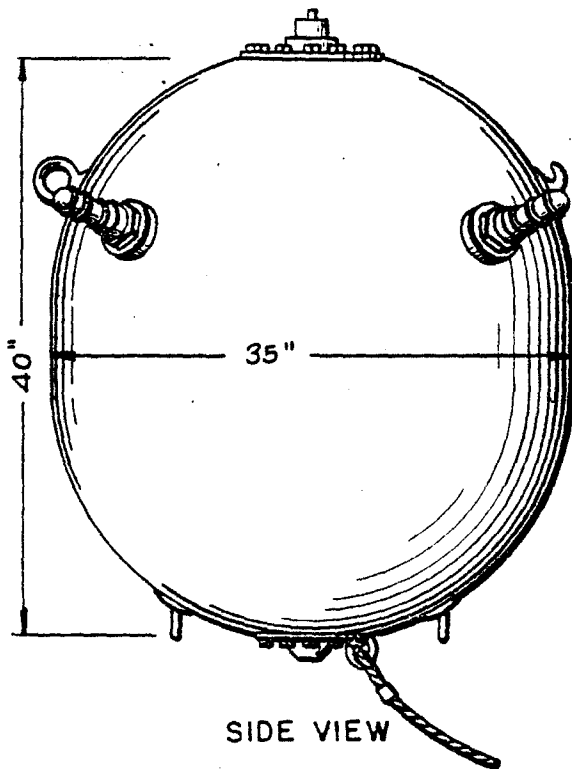

SIDE VIEW

TYPE-61

4-LEAD HORNS

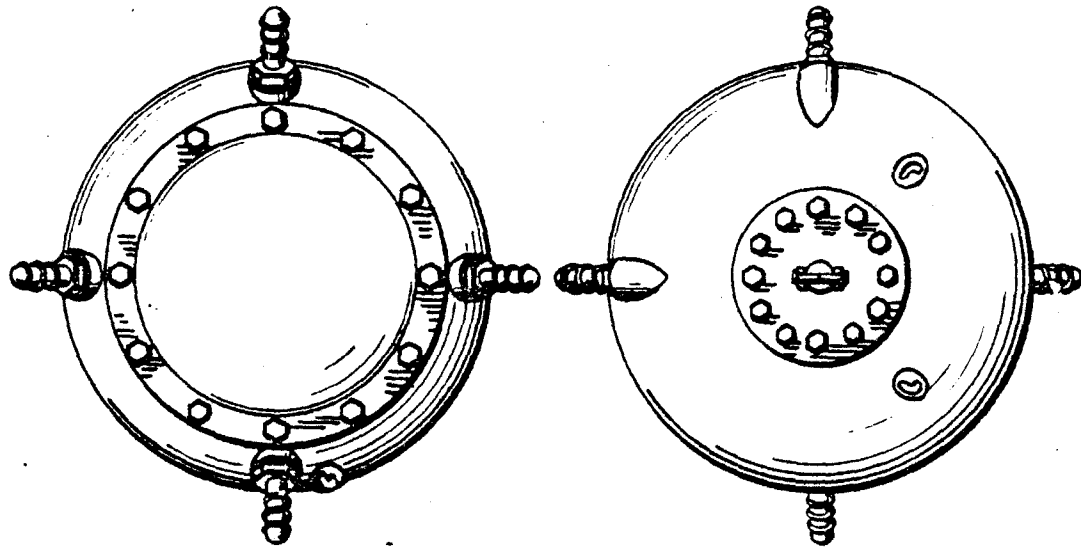

TOP VIEW

BOTTOM VIEW

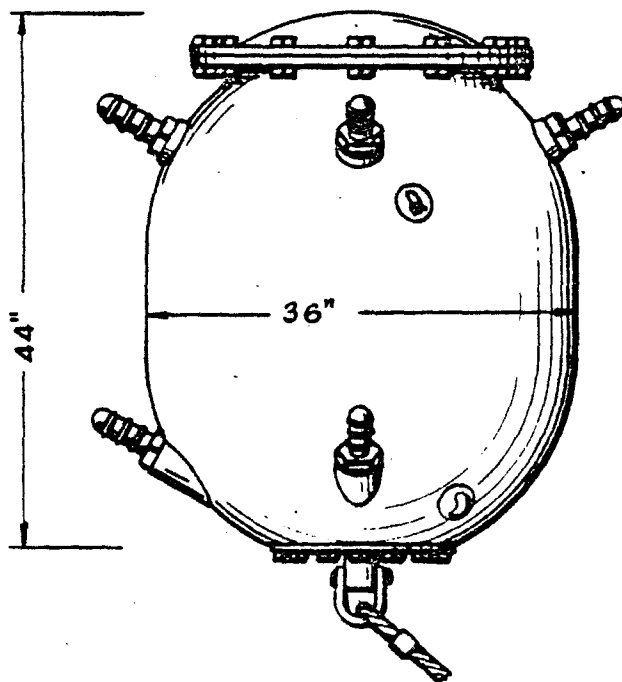

SIDE VIEW

TYPE-16

6-LEAD HORNS

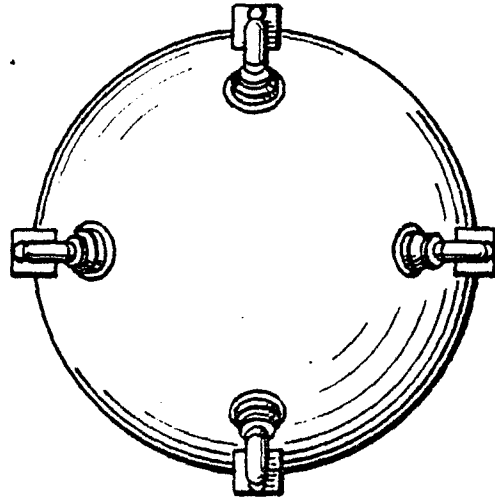

TOP VIEW

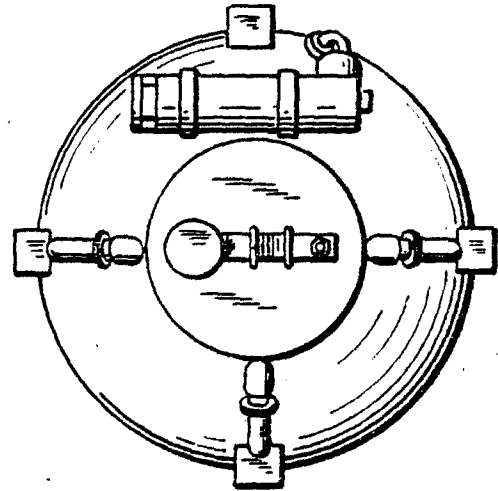

BOTTOM VIEW

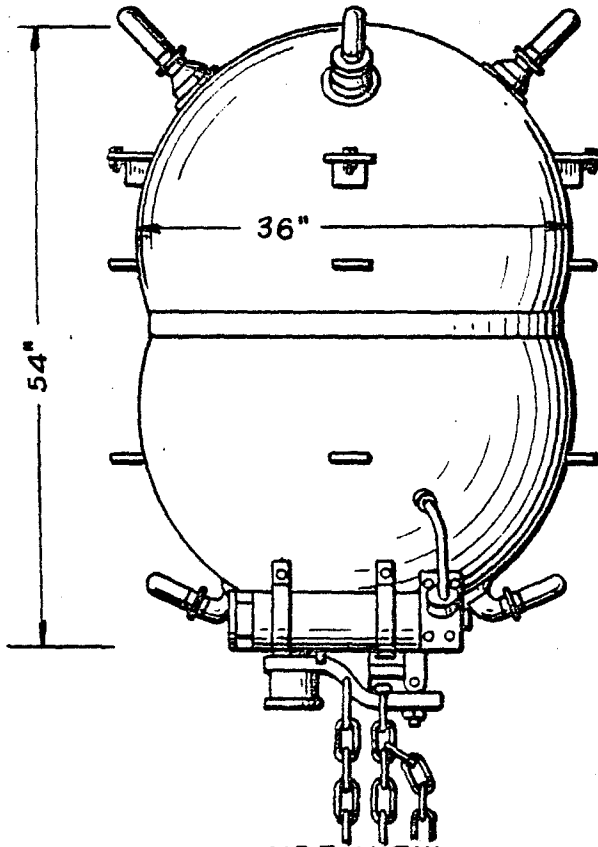

SIDE VIEW

TYPE-44

7-LEAD HORNS

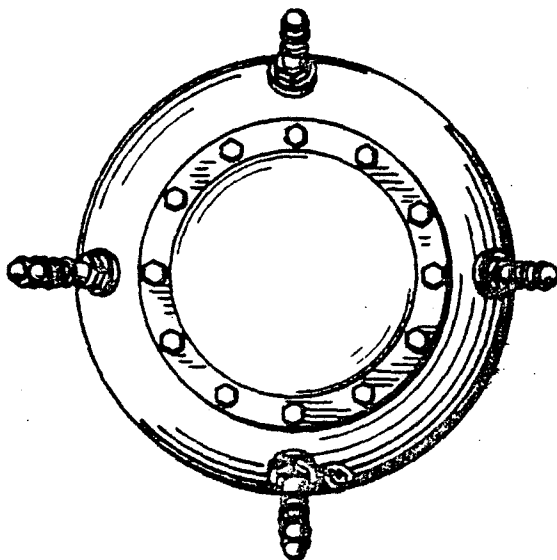

TOP VIEW

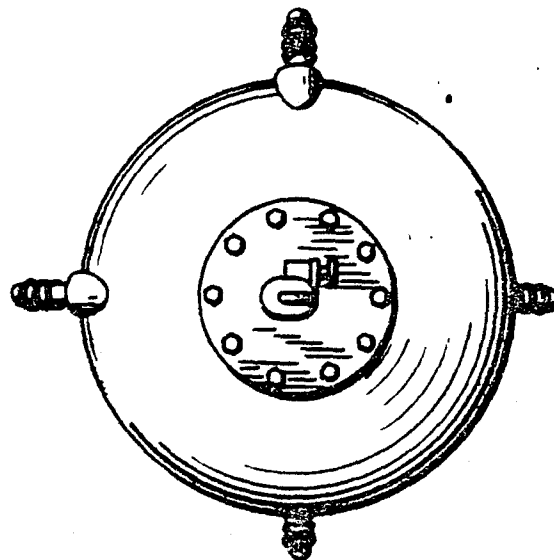

BOTTOM VIEW

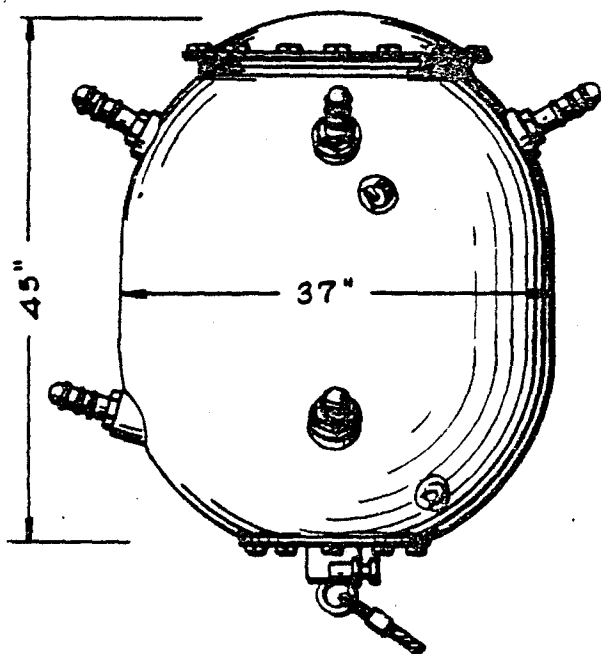

SIDE VIEW

TYPE-33

6-LEAD HORNS

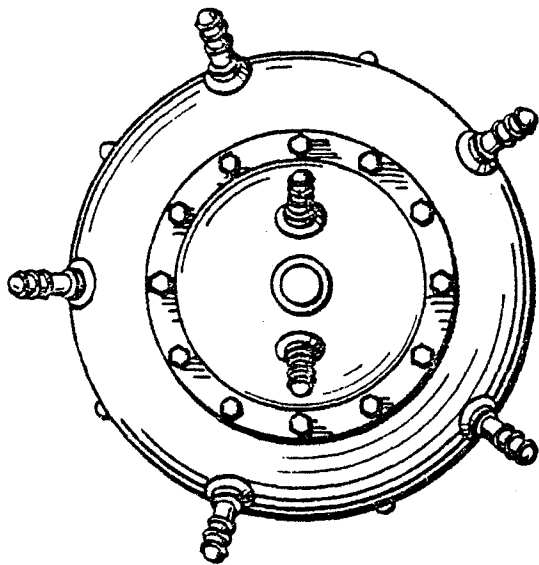

TOP VIEW

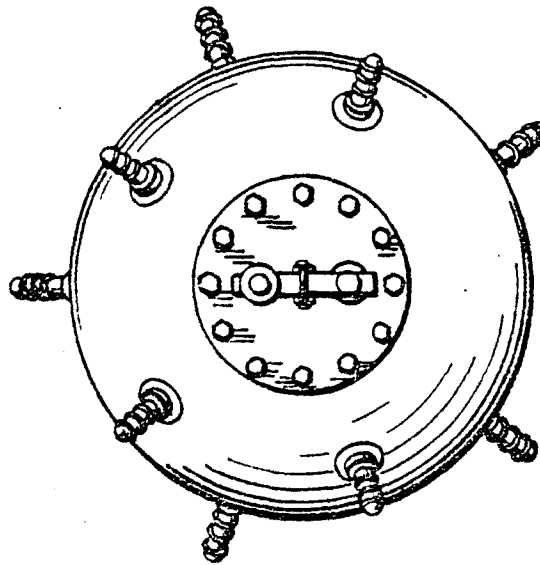

BOTTOM VIEW

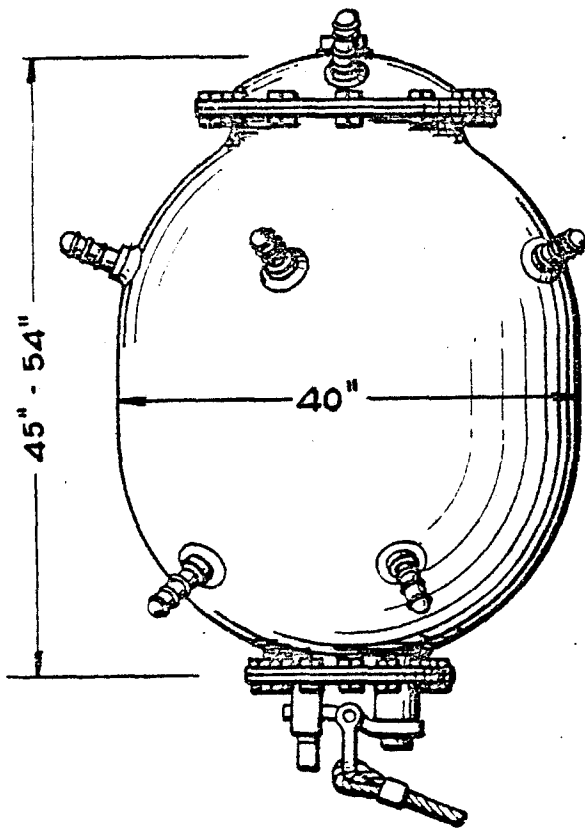

SIDE VIEW

SPIKE HORN

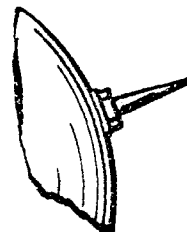

TYPE-14

9 OR 11 BRASS OR SPIKE HORNS

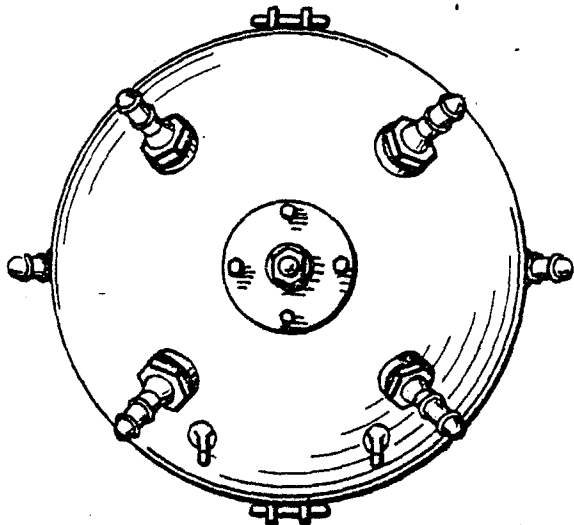

TOP VIEW

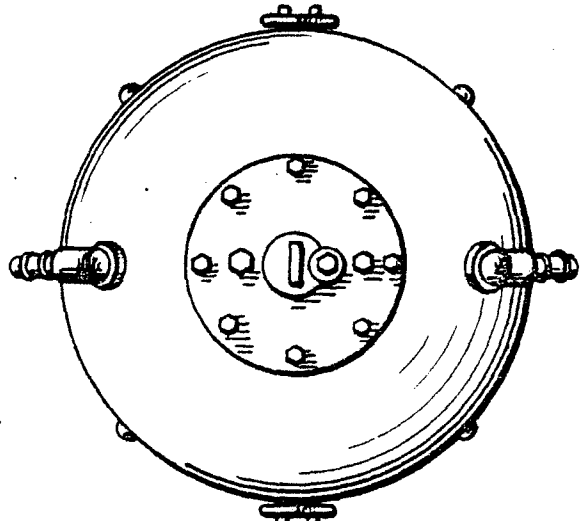

BOTTOM VIEW

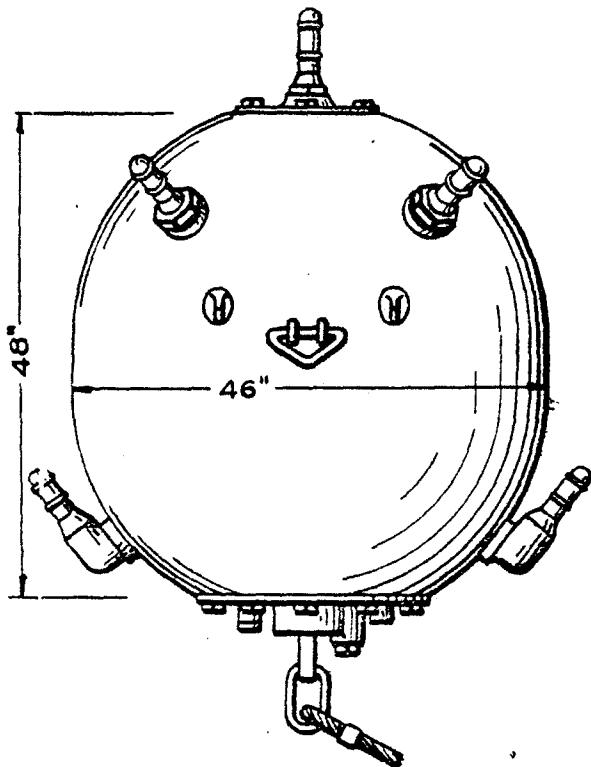

SIDE VIEW

TYPE-86

7-LEAD HORNS

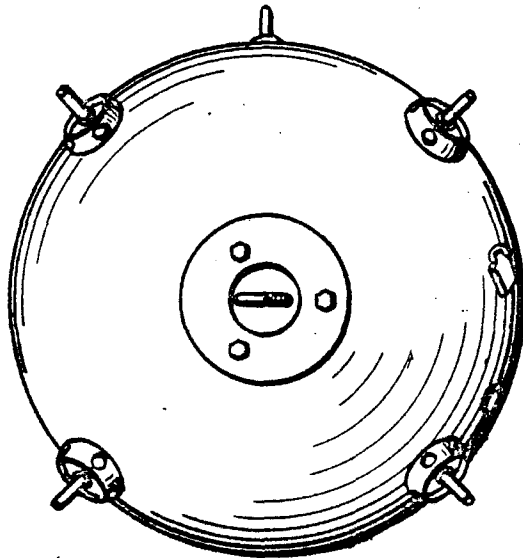

TOP VIEW

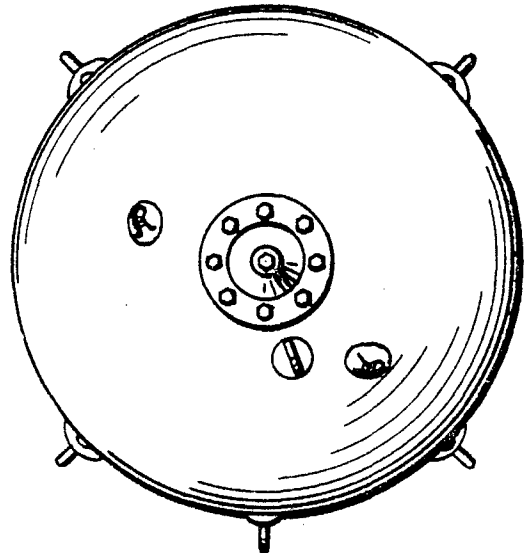

BOTTOM VIEW

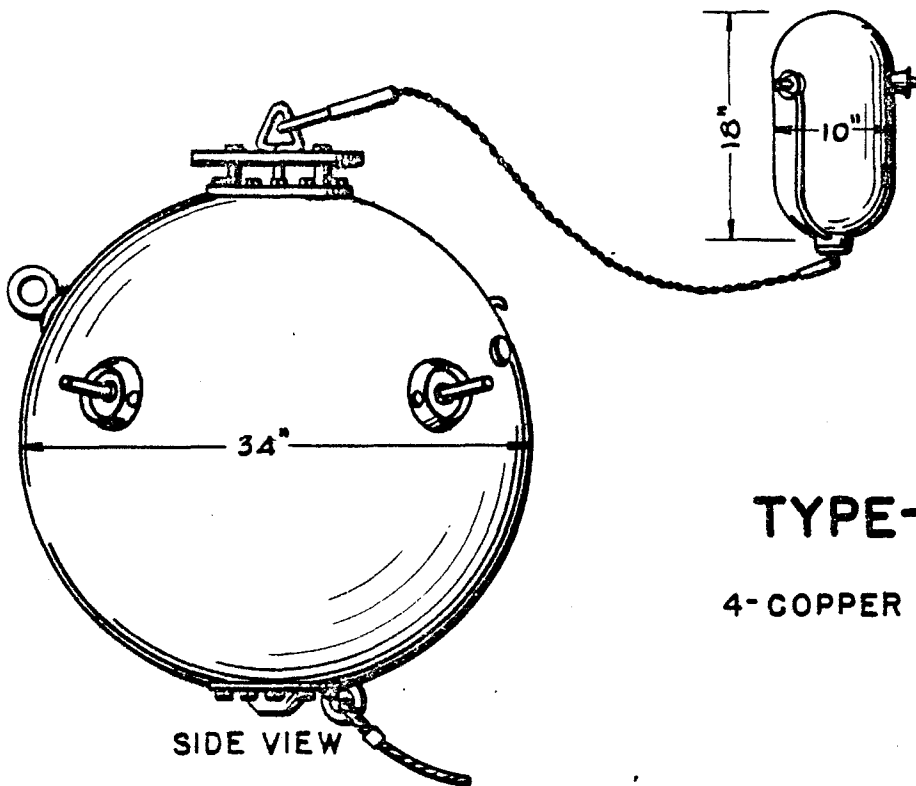

SIDE VIEW

TYPE-62

4-COPPER HORNS

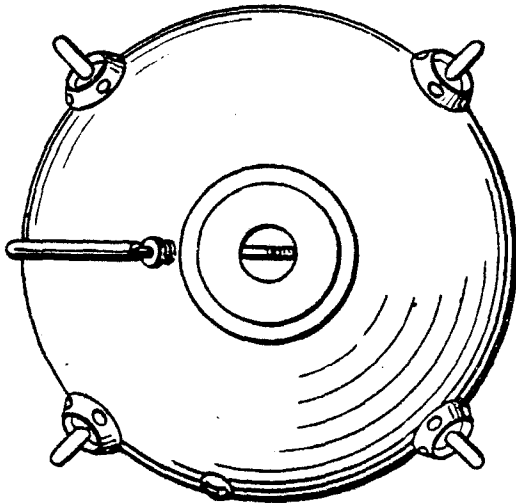

TOP VIEW

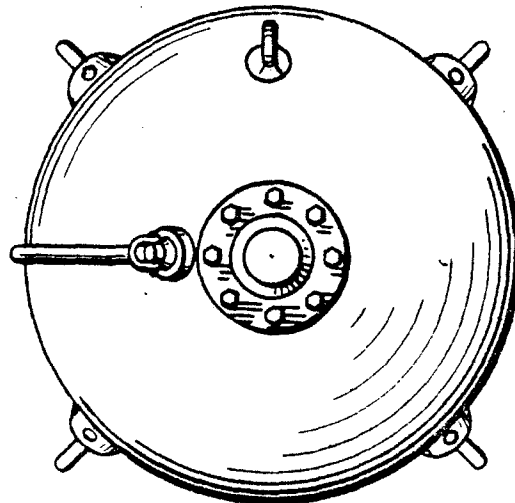

BOTTOM VIEW

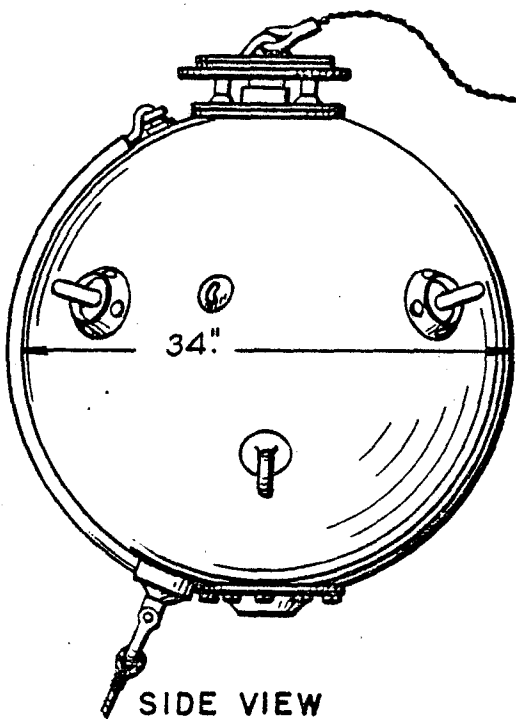

SIDE VIEW

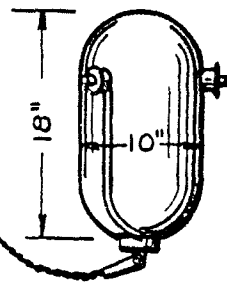

TYPE-64

4-COPPER HORNS

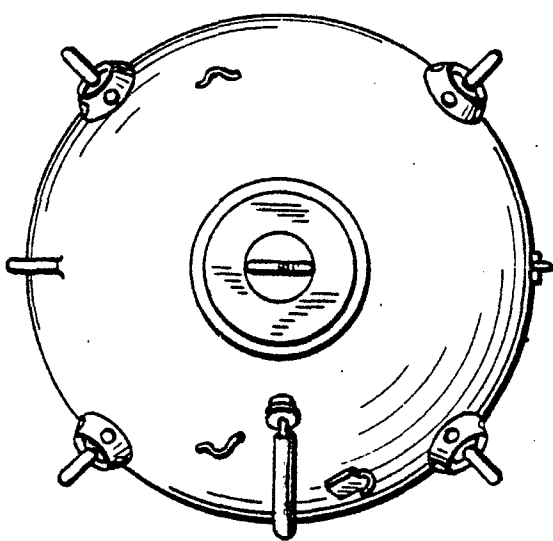

TOP VIEW

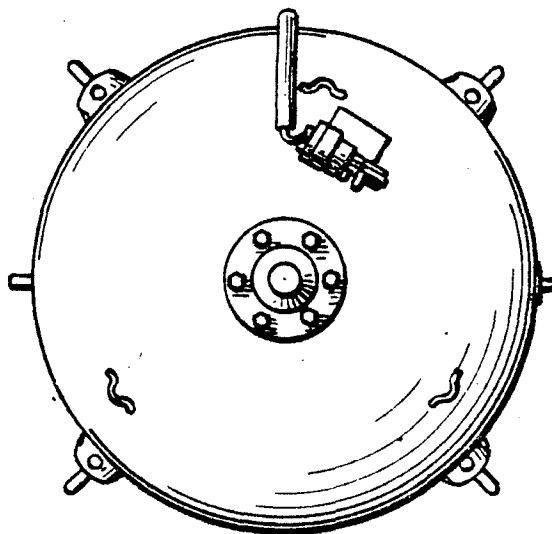

BOTTOM VIEW

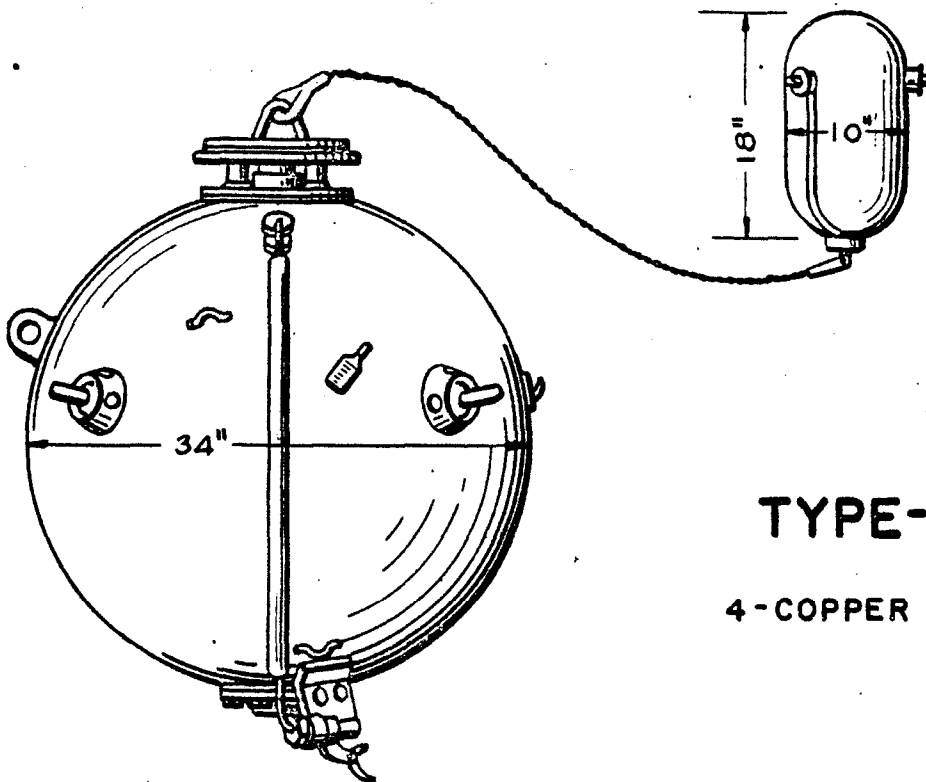

SIDE VIEW

TYPE-63

4 - COPPER HORNS

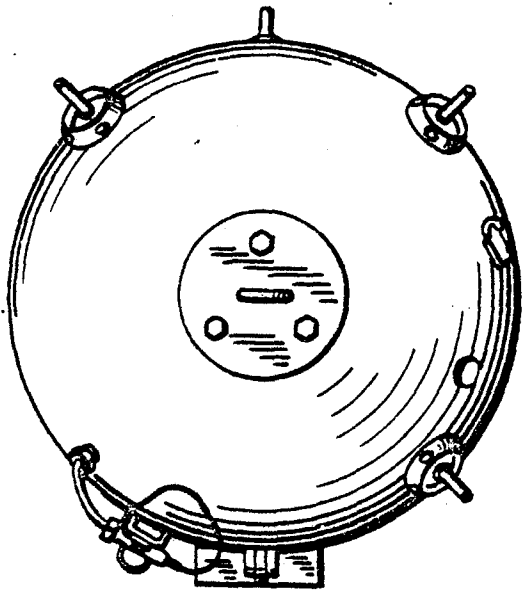

TOP VIEW

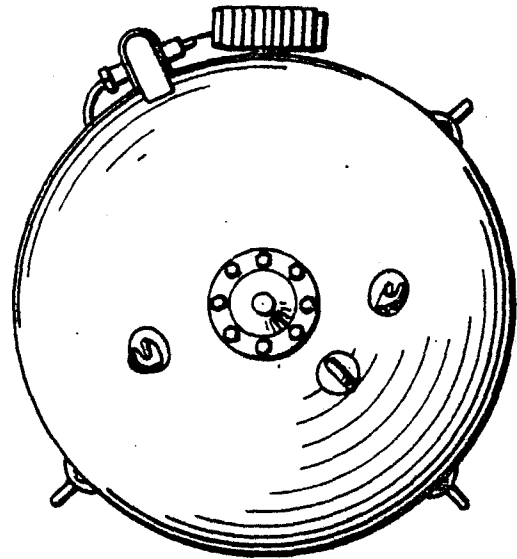

BOTTOM VIEW

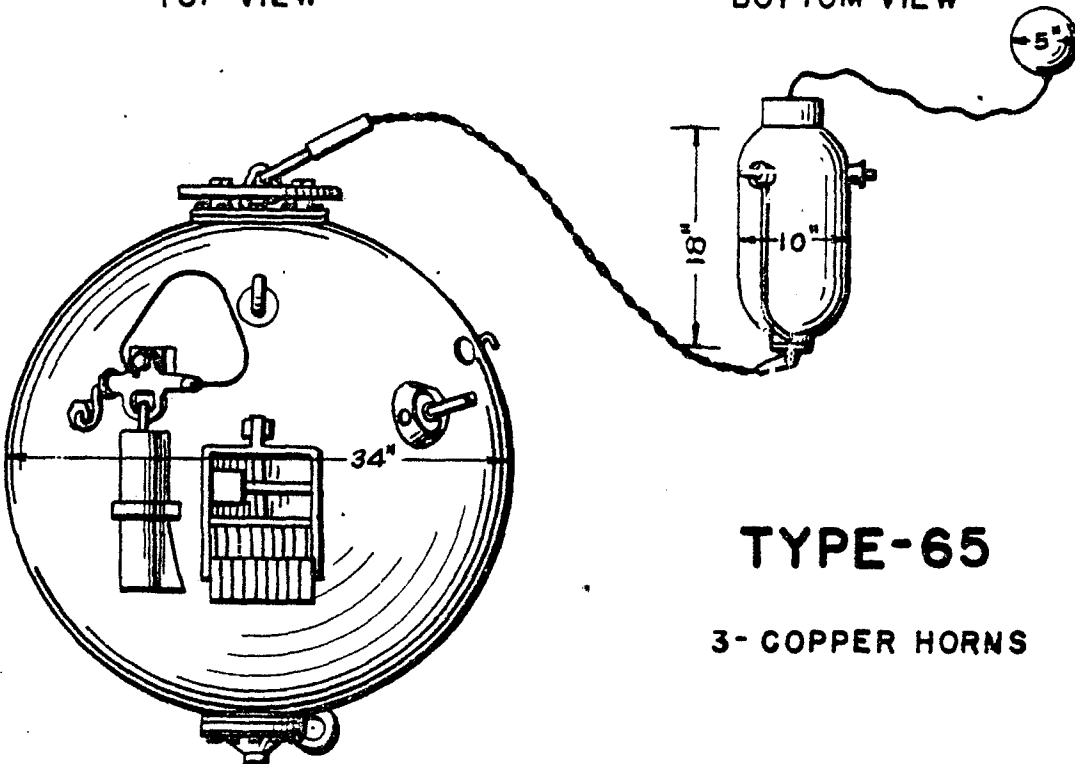

SIDE VIEW

TYPE-65

3- COPPER HORNS

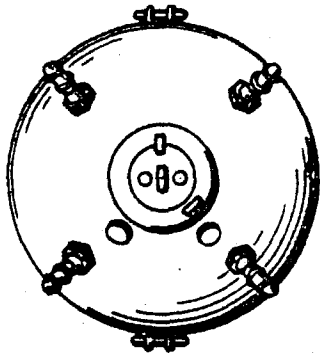

TOP VIEW

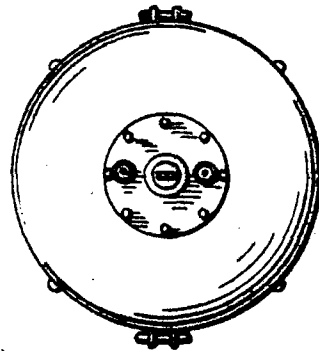

BOTTOM VIEW

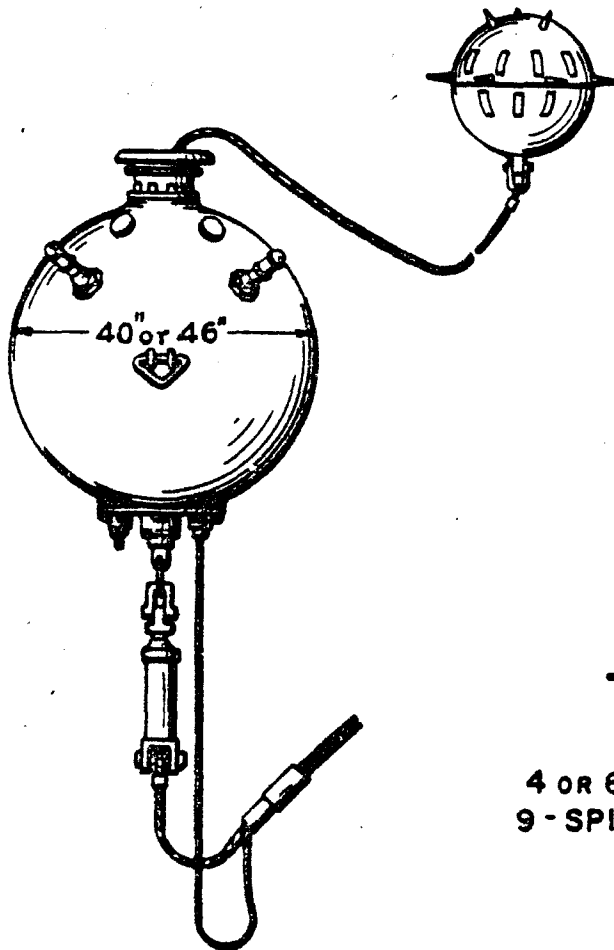

SIDE VIEW

TYPE-88

4 OR 6 LEAD HORNS
9 - SPIKES ON SMALL FLOAT

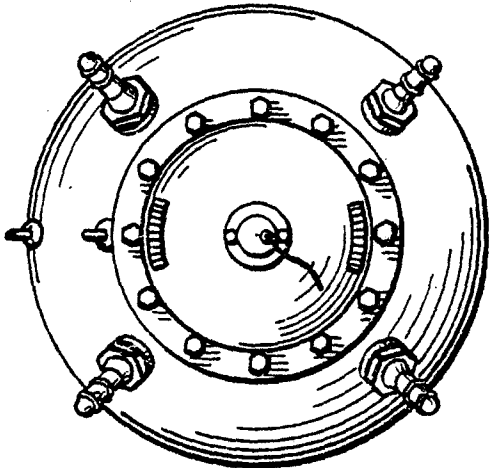

TOP VIEW

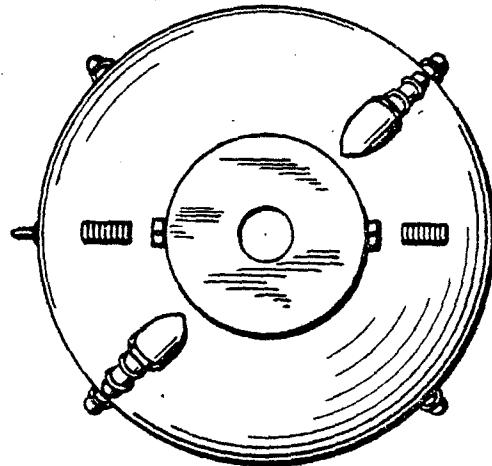

BOTTOM VIEW

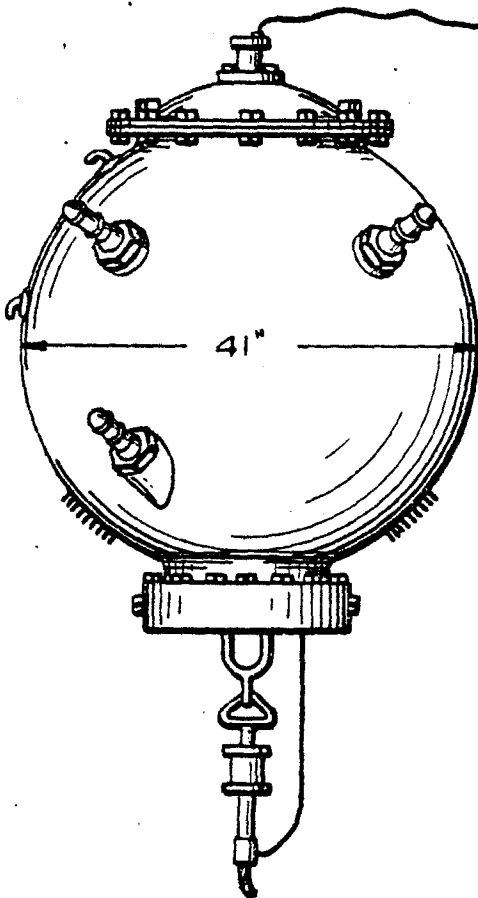

SIDE VIEW

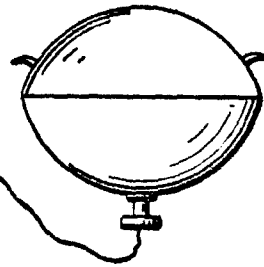

TYPE-18
6-LEAD HORNS

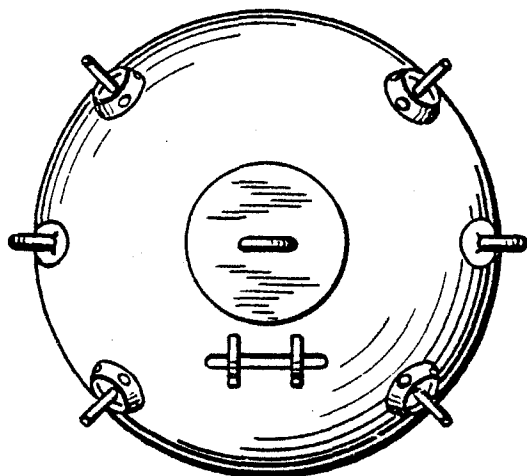

TOP VIEW

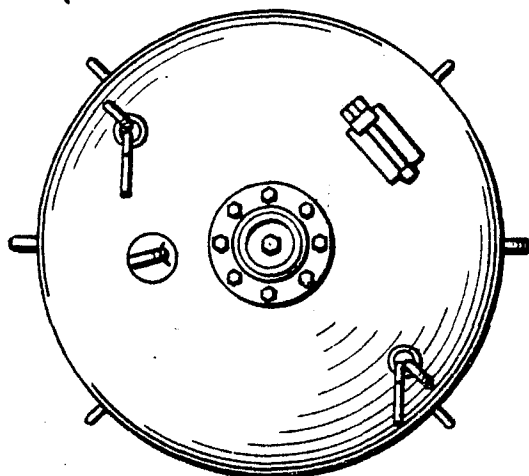

BOTTOM VIEW

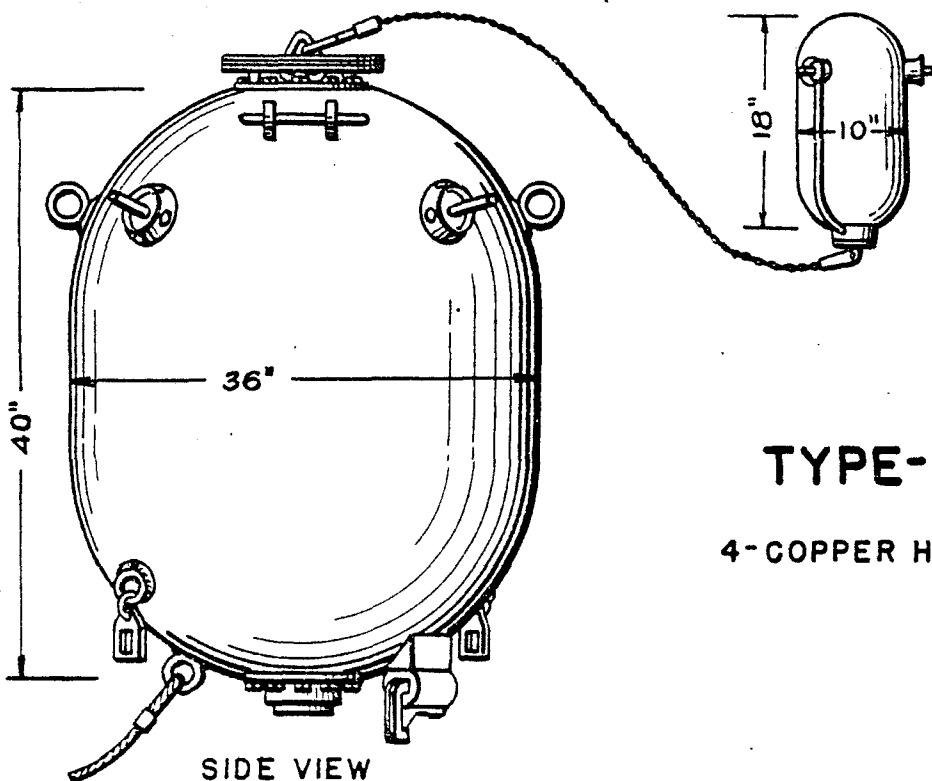

SIDE VIEW

TYPE-67

4-COPPER HORNS

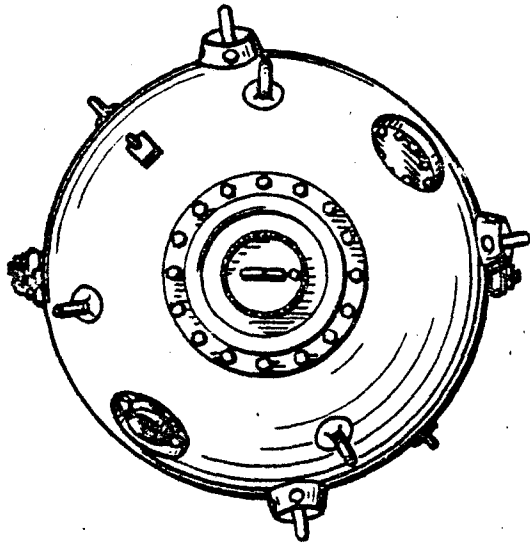

TOP VIEW

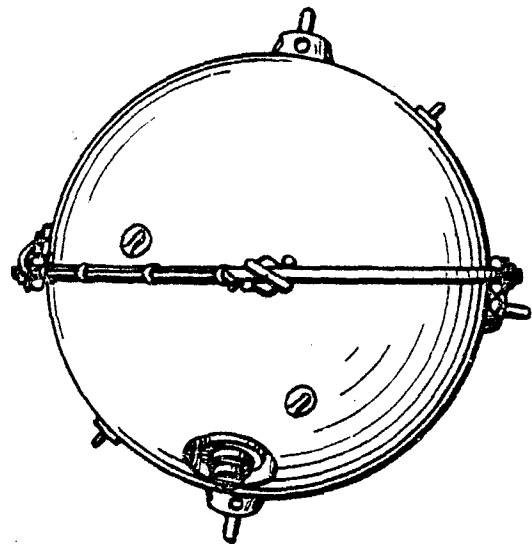

BOTTOM VIEW

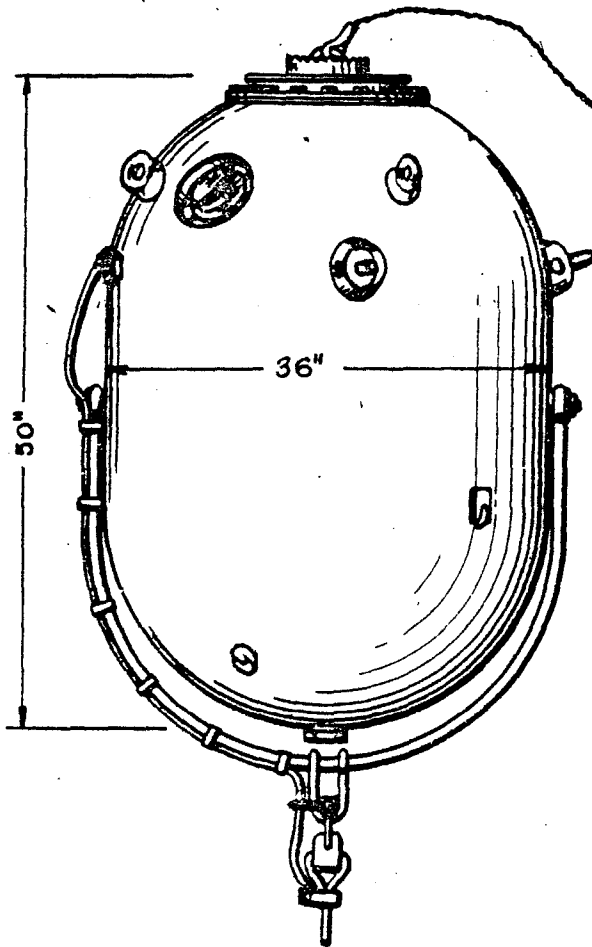

SIDE VIEW

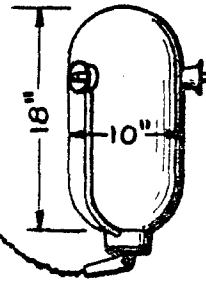

TYPE-72

3-COPPER HORNS

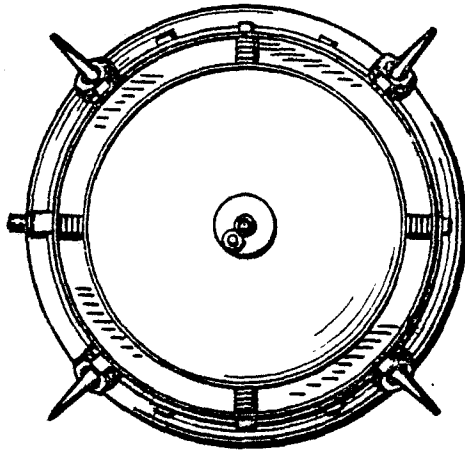

TOP VIEW

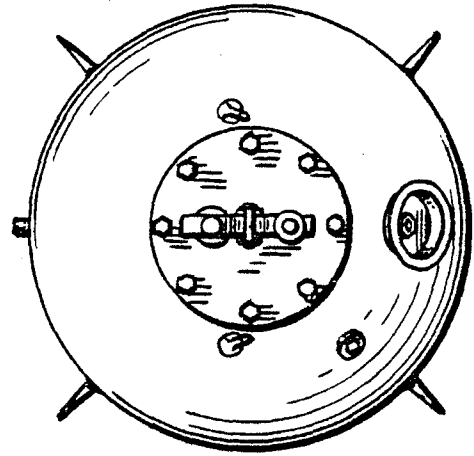

BOTTOM VIEW

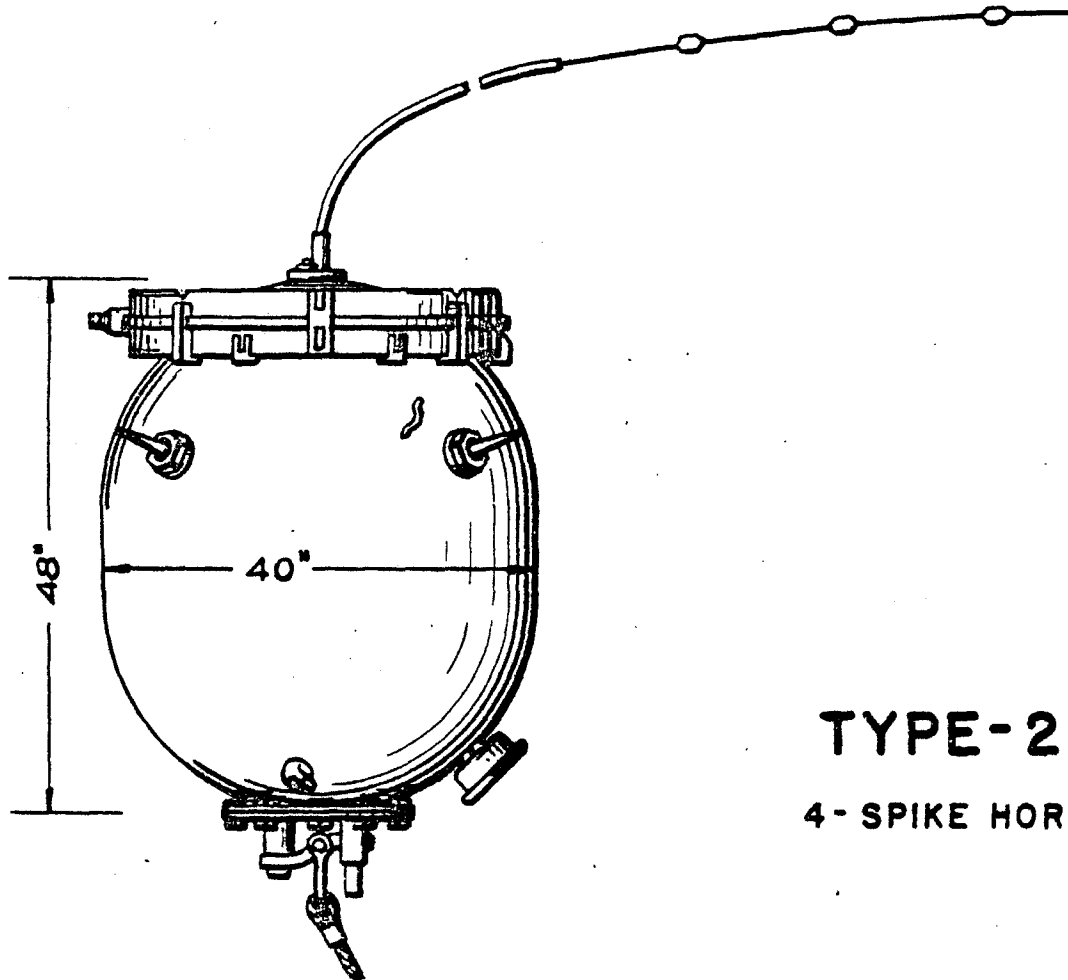

SIDE VIEW

TYPE-20
4 - SPIKE HORNS

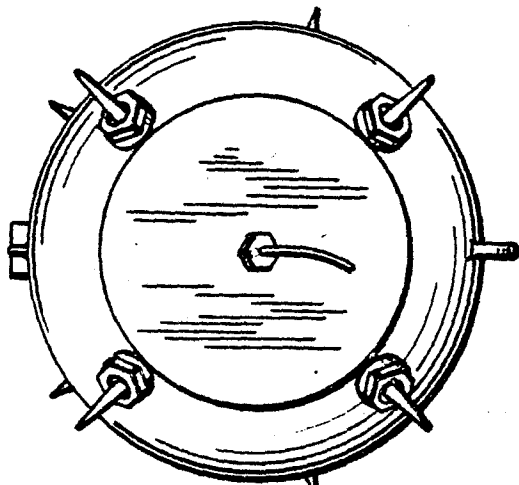

TOP VIEW

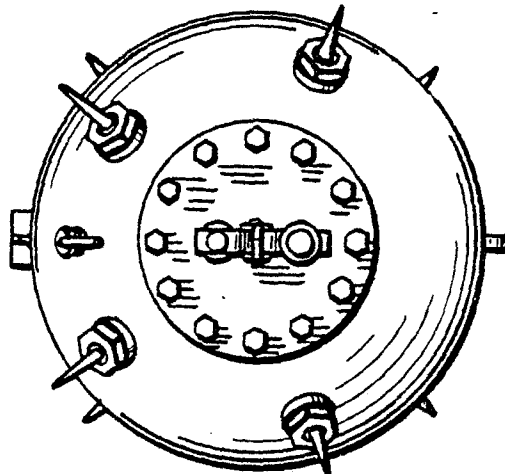

BOTTOM VIEW

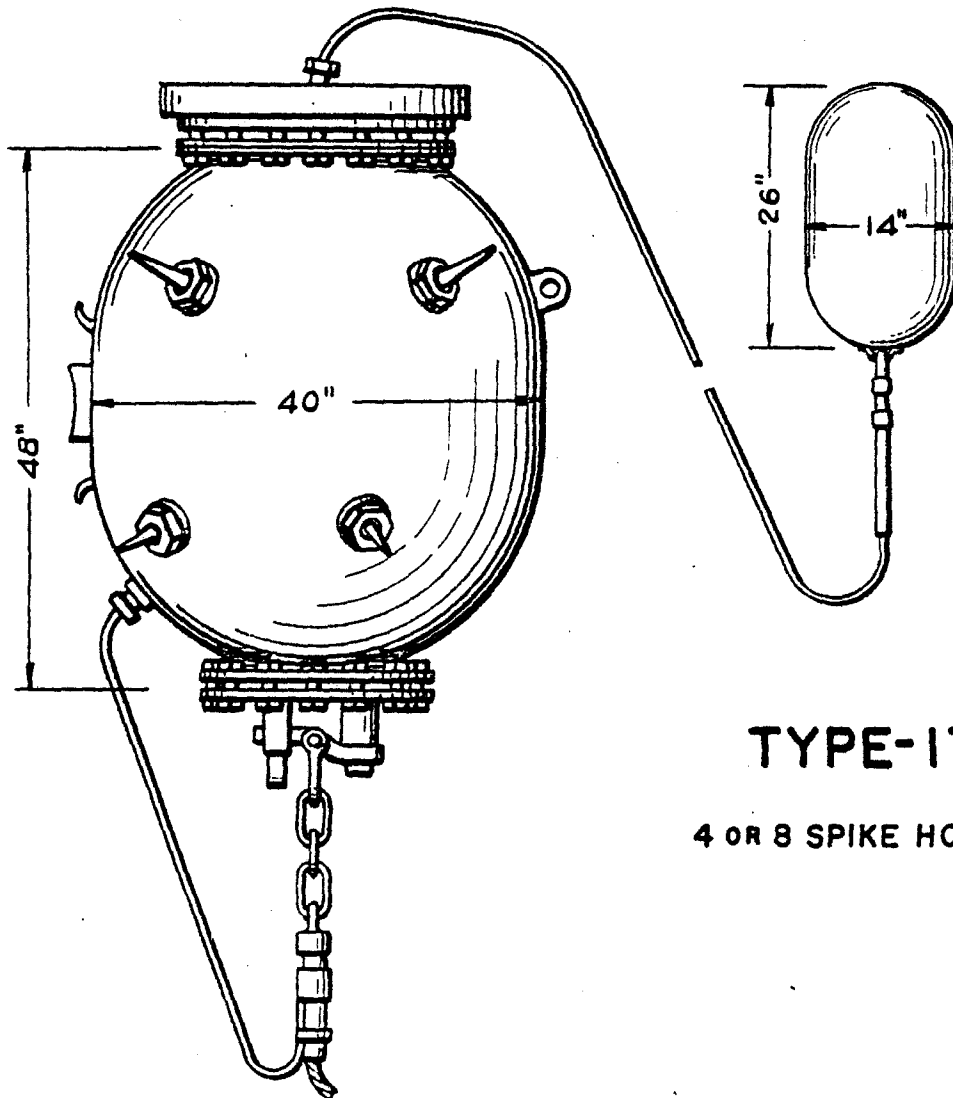

SIDE VIEW

TYPE-17

4 OR 8 SPIKE HORNS

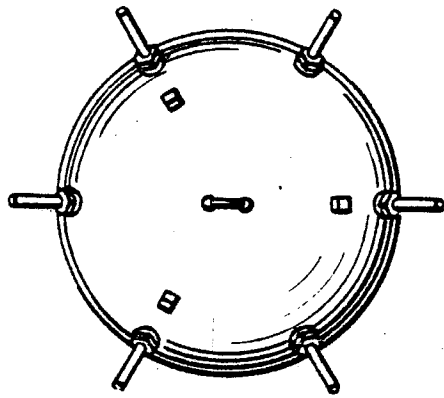

TOP VIEW

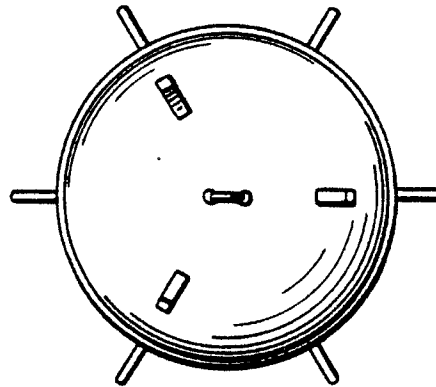

BOTTOM VIEW

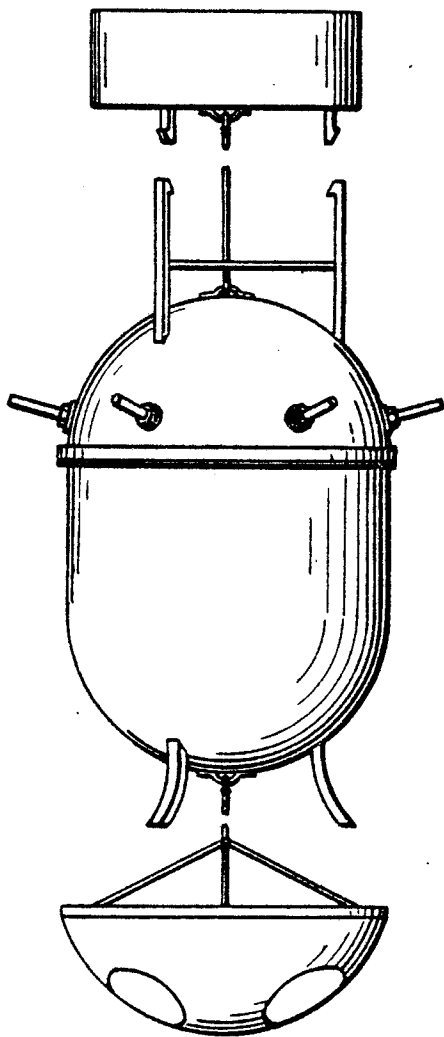

SIDE VIEW

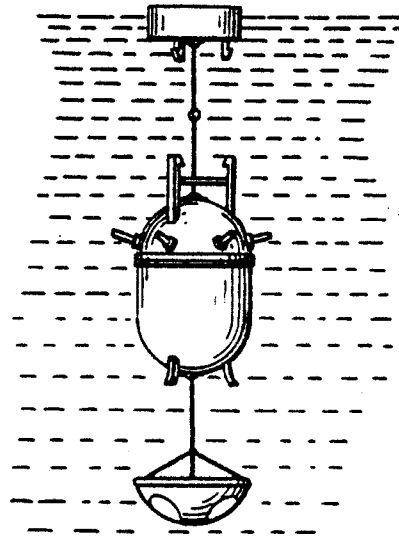

TYPE-46

6-HORNS
DIMENSIONS NOT KNOWN

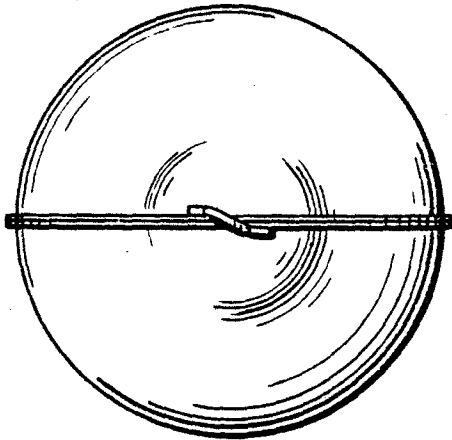

TOP VIEW

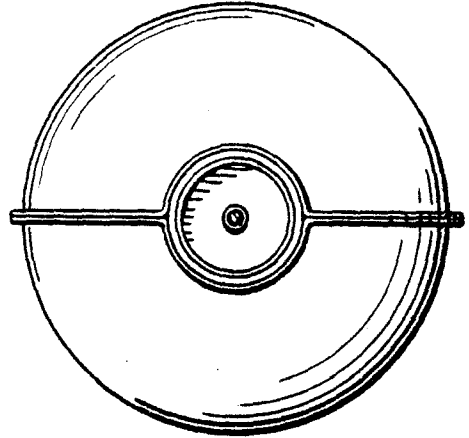

BOTTOM VIEW

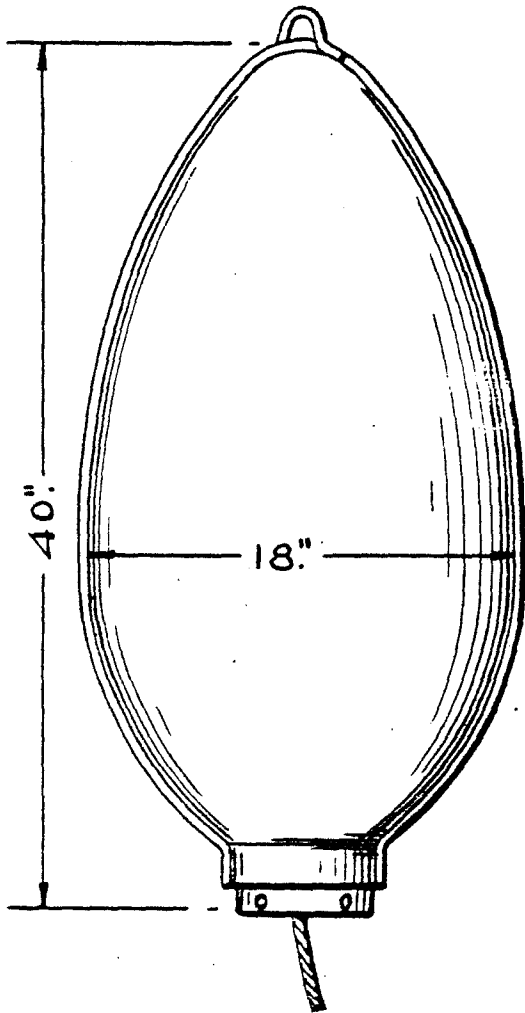

SIDE VIEW

TYPE-76

NO HORNS

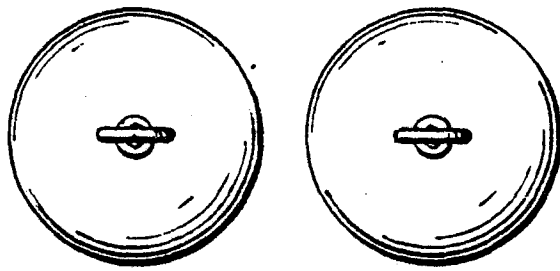

TOP VIEWS

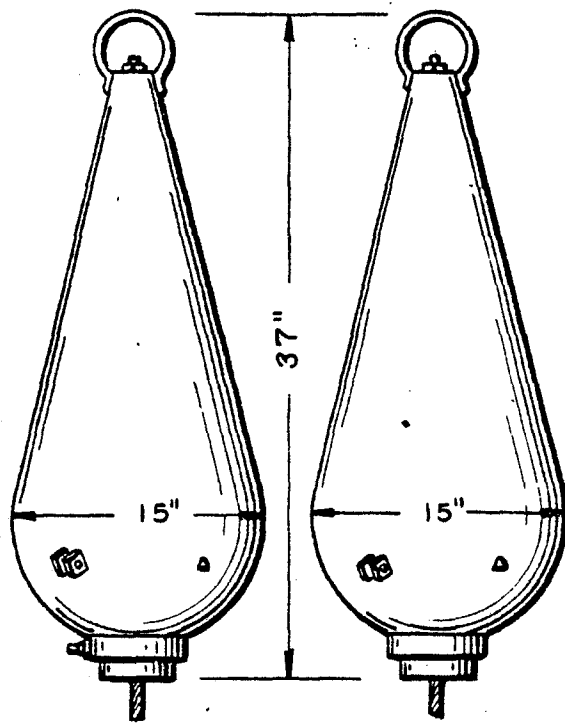

A SIDE VIEWS B

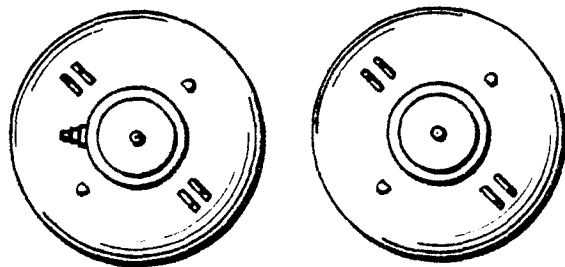

BOTTOM VIEWS

TYPE-81

NO HORNS

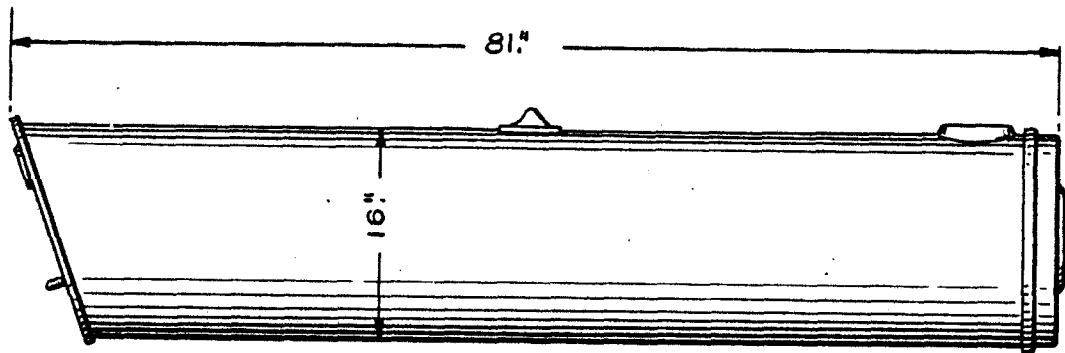

SIDE VIEW

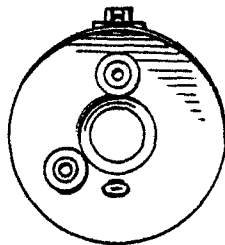

FRONT VIEW

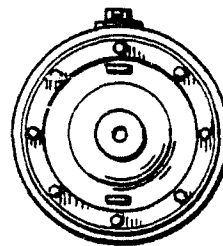

REAR VIEW

TYPE - 24

NO HORNS

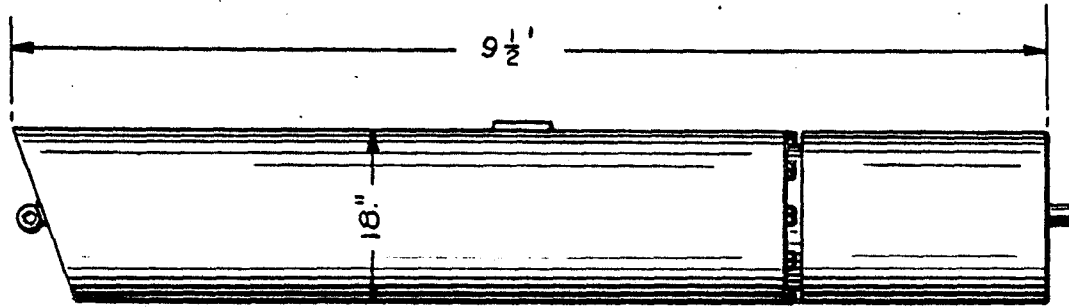

SIDE VIEW

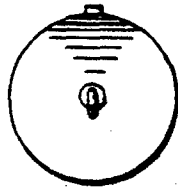

FRONT VIEW

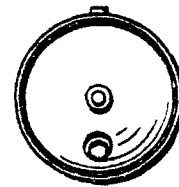

REAR VIEW

TYPE - 23

NO HORNS

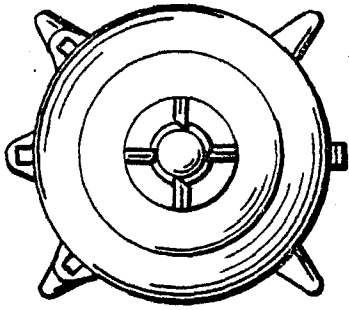

TOP VIEW

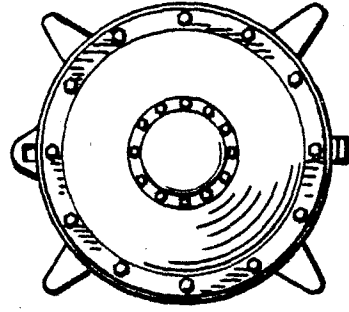

BOTTOM VIEW

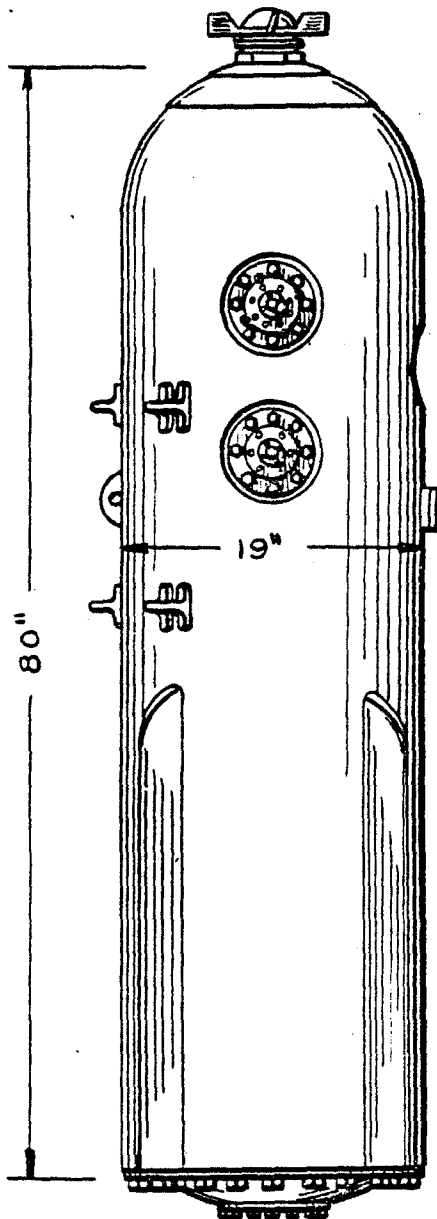

SIDE VIEW

TYPE-68

NO HORNS

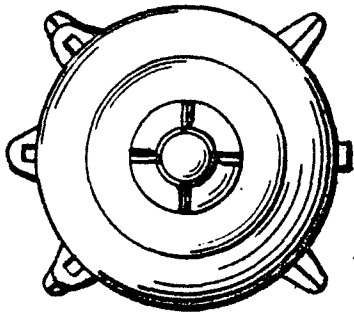

TOP VIEW

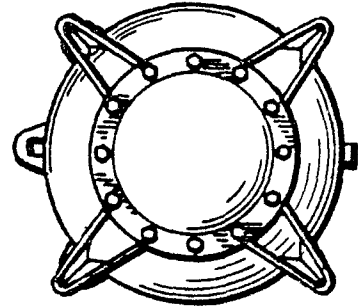

BOTTOM VIEW

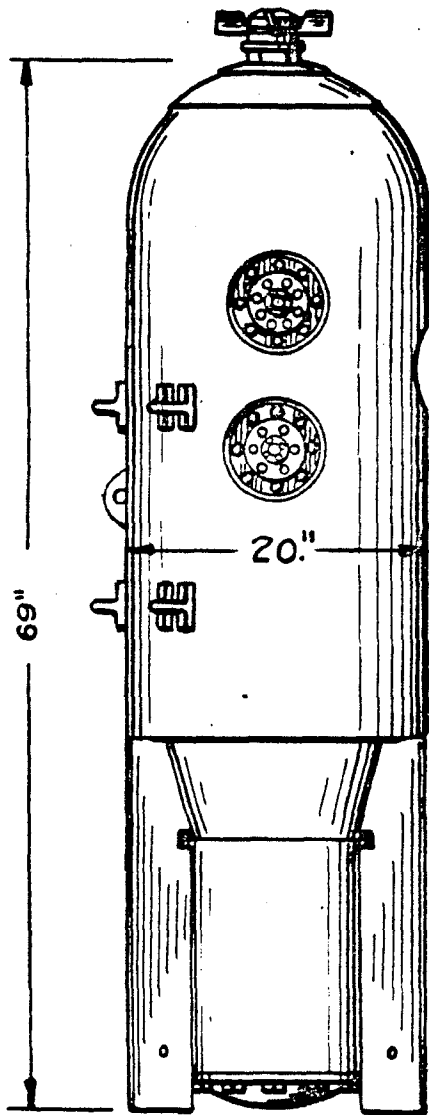

SIDE VIEW

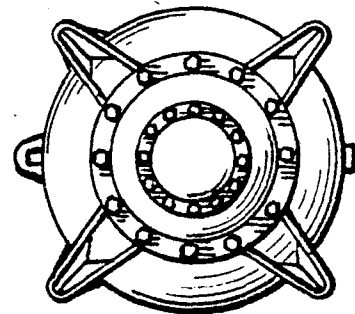

BOTTOM VIEW

TYPE-74

SAME AS TYPE-70 EXCEPT FOR BOTTOM PLATE.

TYPE-70

NO HORNS

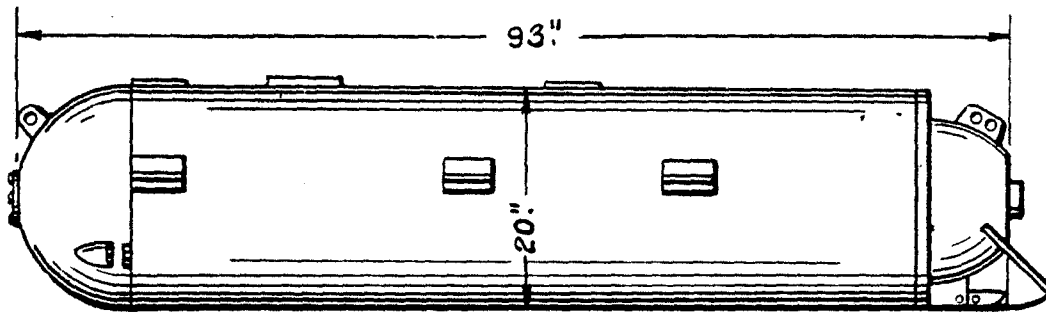

SIDE VIEW

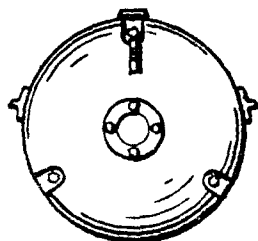

FRONT VIEW

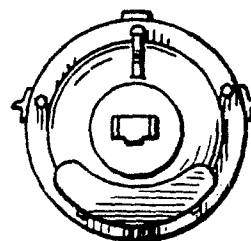

REAR VIEW

TYPE - 22

NO HORNS

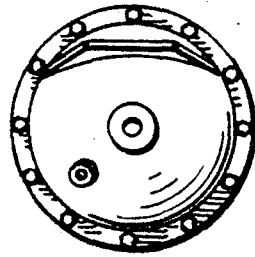

TOP VIEW

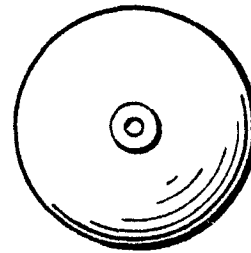

BOTTOM VIEW

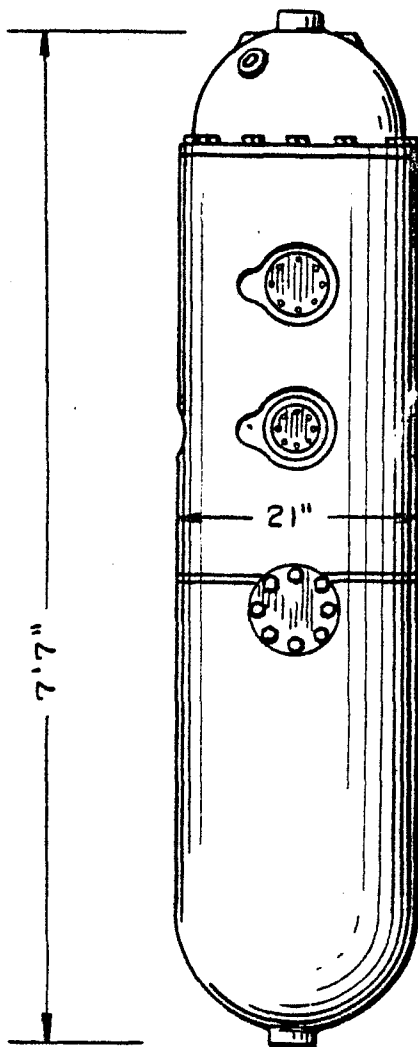

SIDE VIEW

TYPE-101

NO HORNS

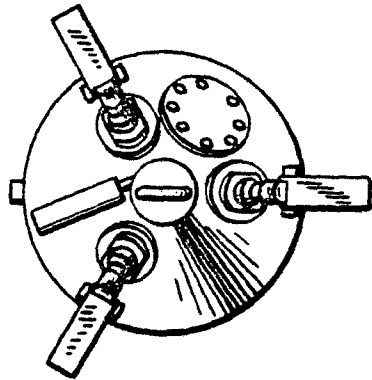

TOP VIEW

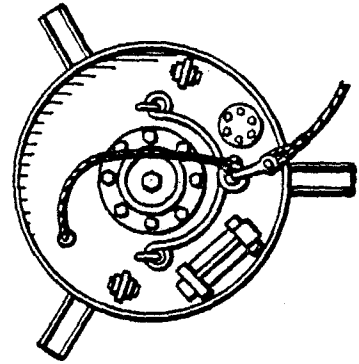

BOTTOM VIEW

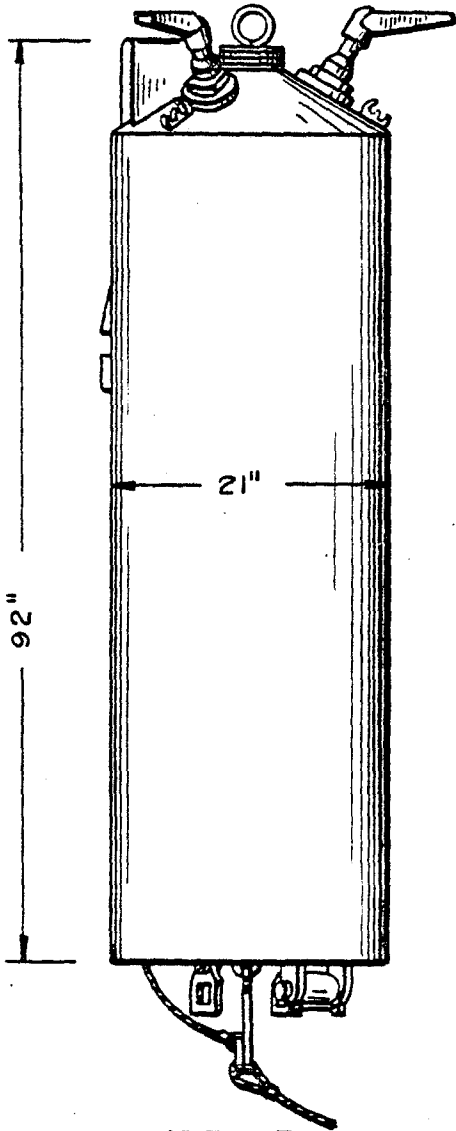

SIDE VIEW

TYPE-66

3-LEAD HORNS

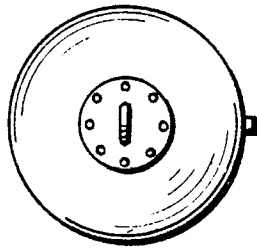

TOP VIEW

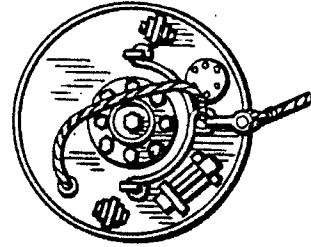

BOTTOM VIEW

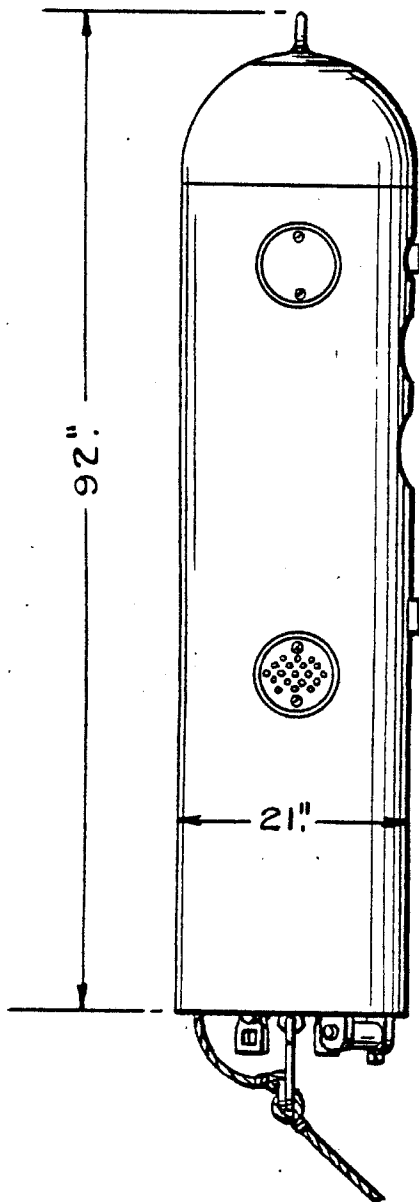

SIDE VIEW

TYPE - 73
NO HORNS

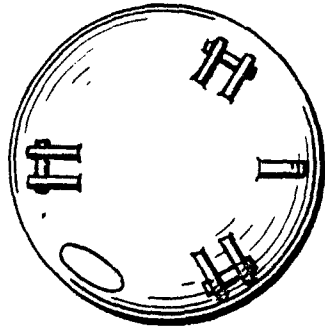

TOP VIEW

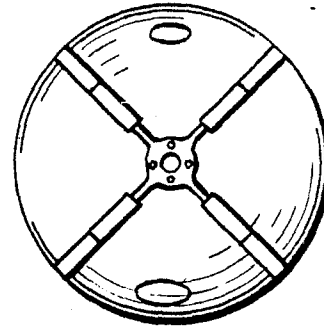

BOTTOM VIEW

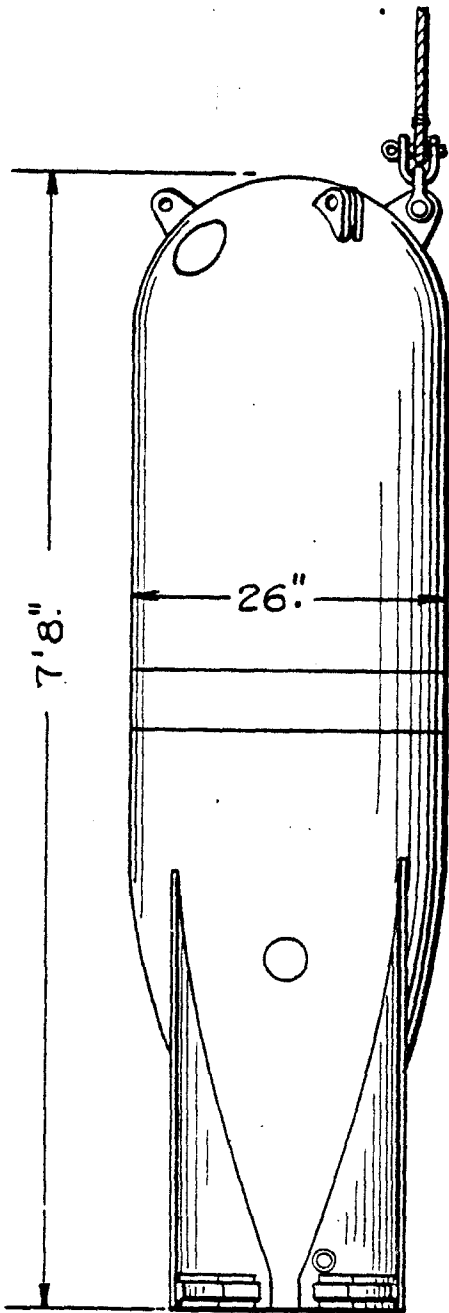

SIDE VIEW

TYPE-107

NO HORNS

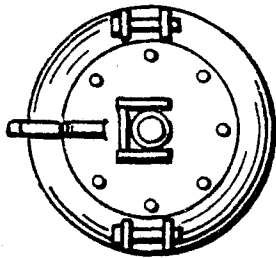

TOP VIEW

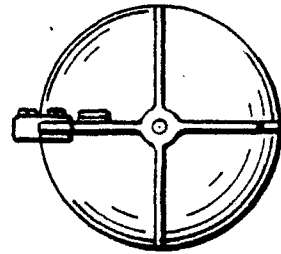

BOTTOM VIEW

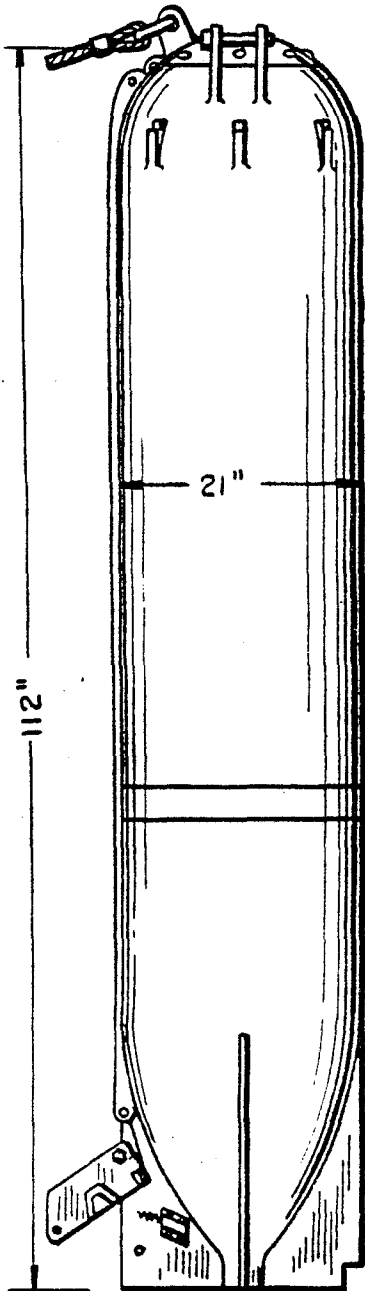

SIDE VIEW

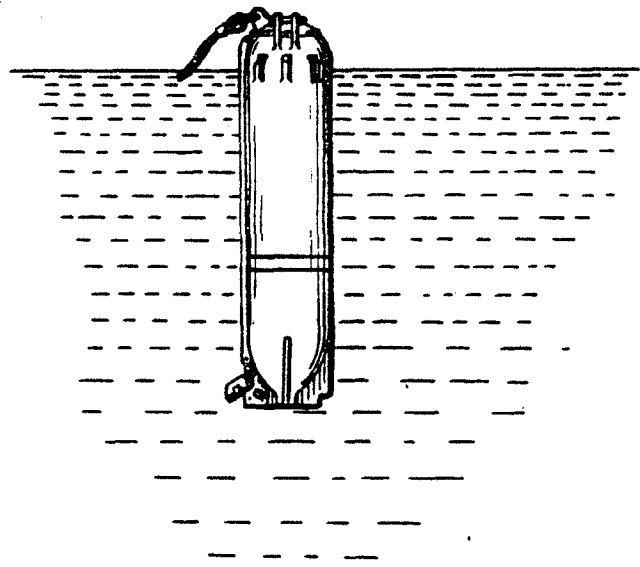

TYPE-105

NO HORNS

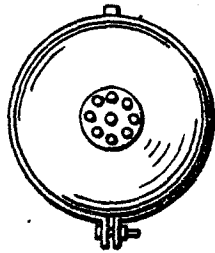

TOP VIEW

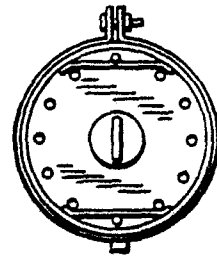

BOTTOM VIEW



SIDE VIEW

TYPE-69

NO HORNS

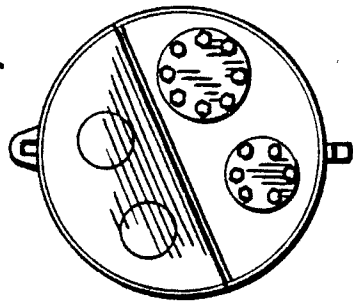

TOP VIEW

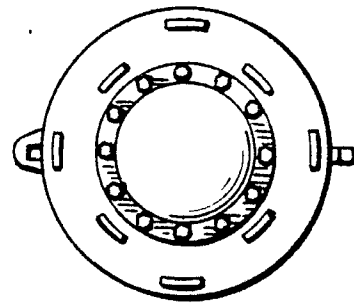

BOTTOM VIEW

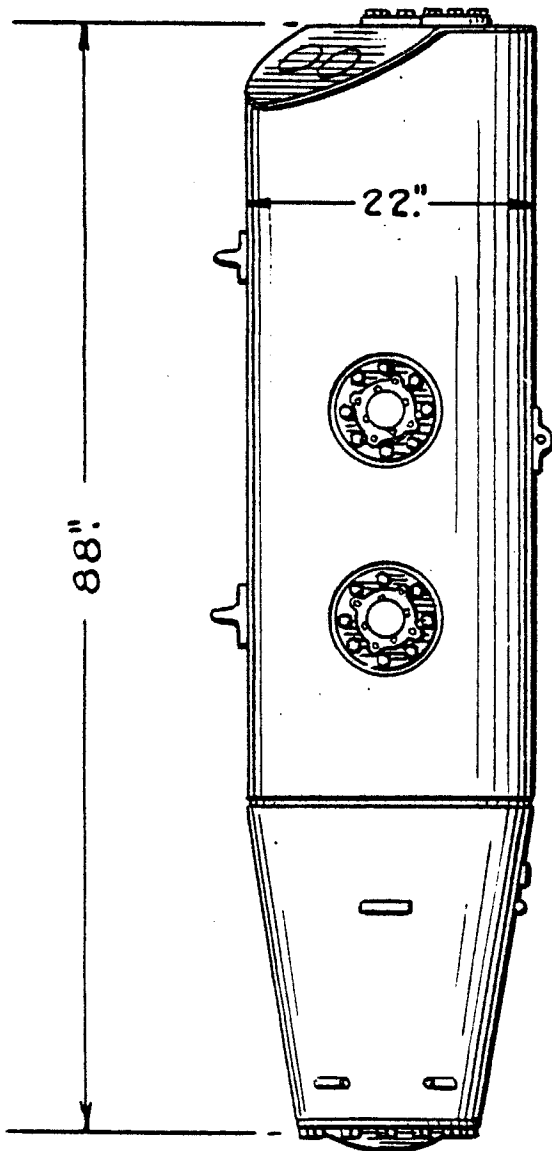

SIDE VIEW

TYPE-77

NO HORNS

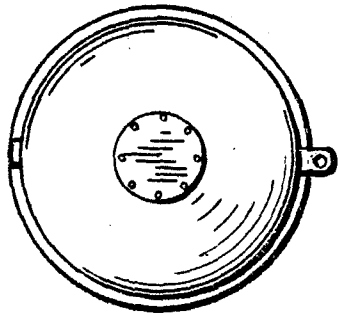

TOP VIEW

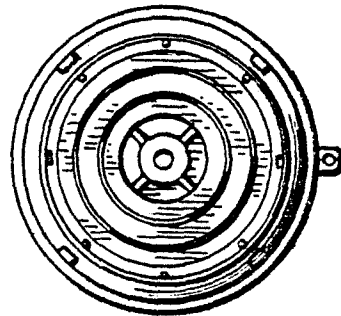

BOTTOM VIEW

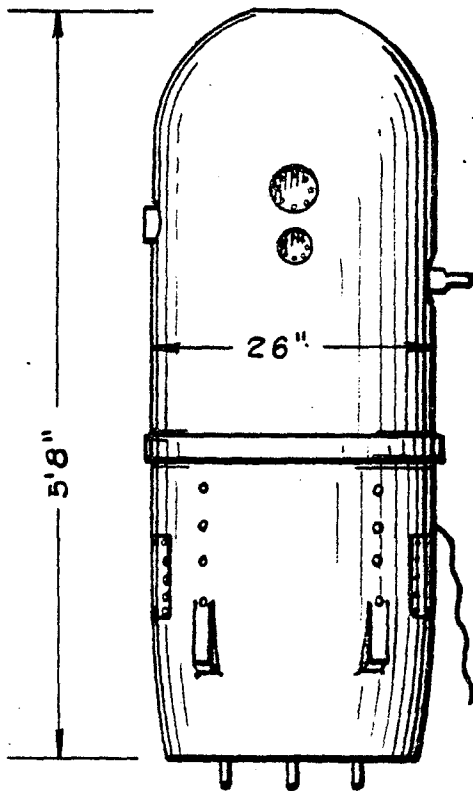

SIDE VIEW

TYPE-103

NO HORNS

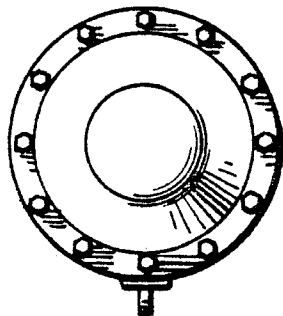

TOP VIEW

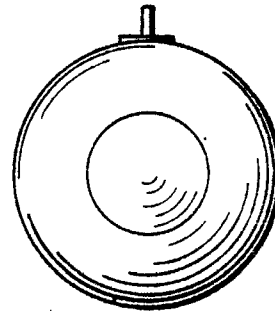

BOTTOM VIEW

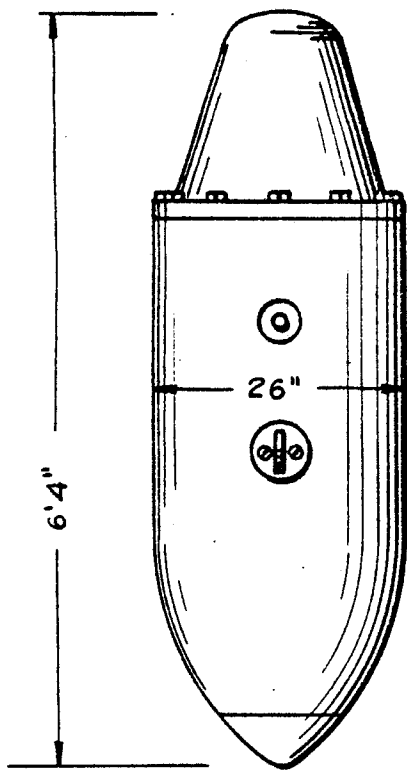

SIDE VIEW

TYPE-104

NO HORNS
USUALLY PAINTED LIGHT BLUE

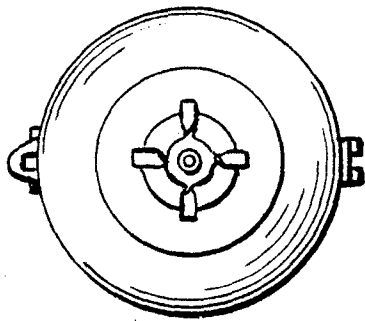

TOP VIEW

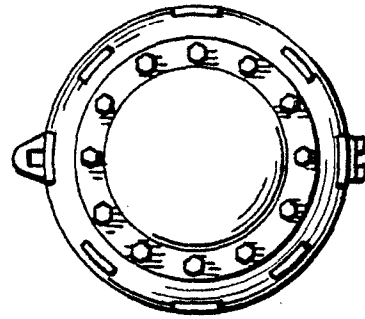

BOTTOM VIEW

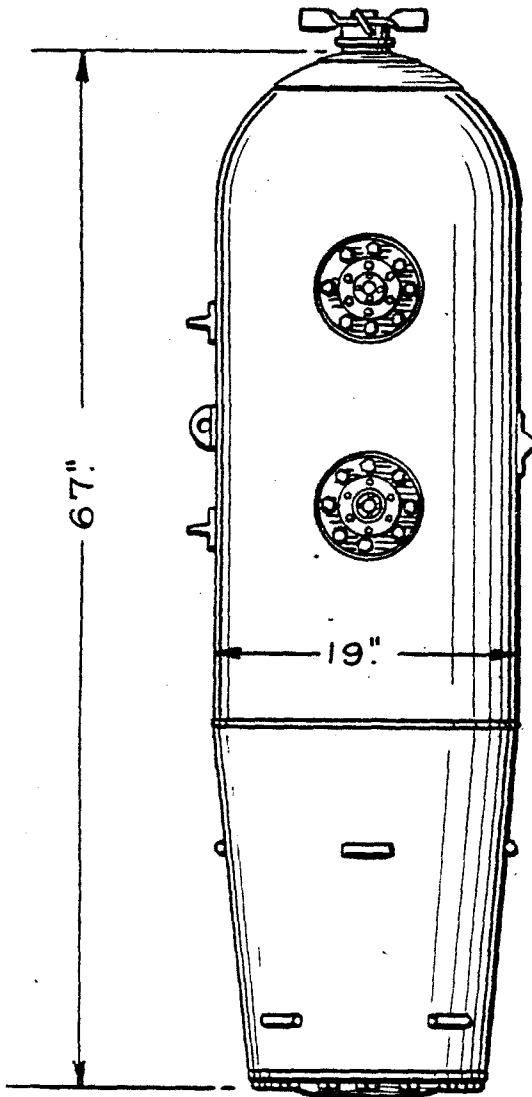

SIDE VIEW

TYPE - 78
NO HORNS

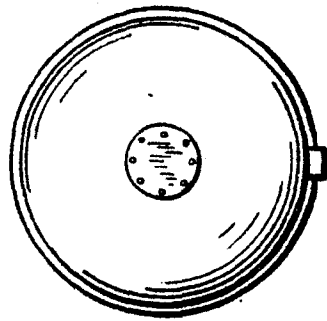

TOP VIEW

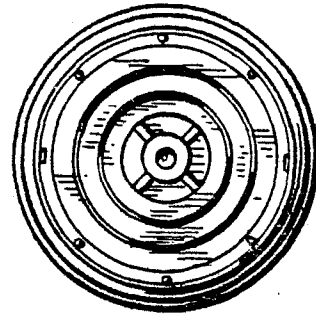

BOTTOM VIEW

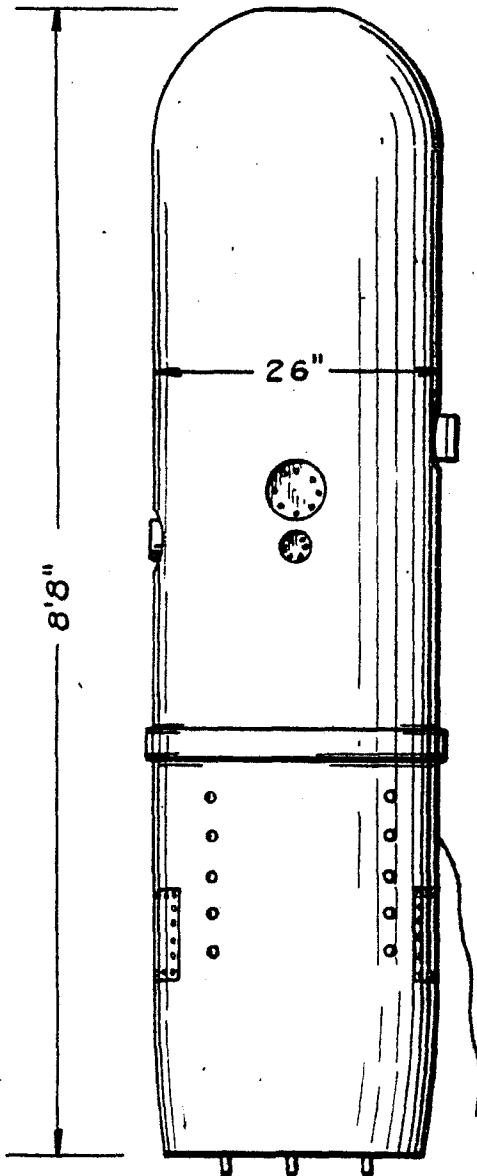

SIDE VIEW

TYPE-102

NO HORNS

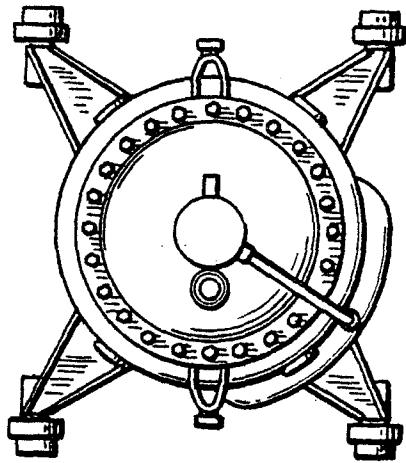

TOP VIEW

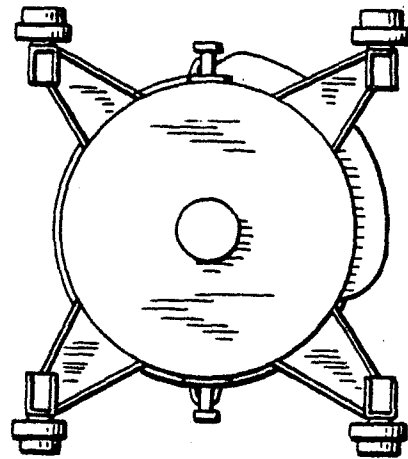

BOTTOM VIEW

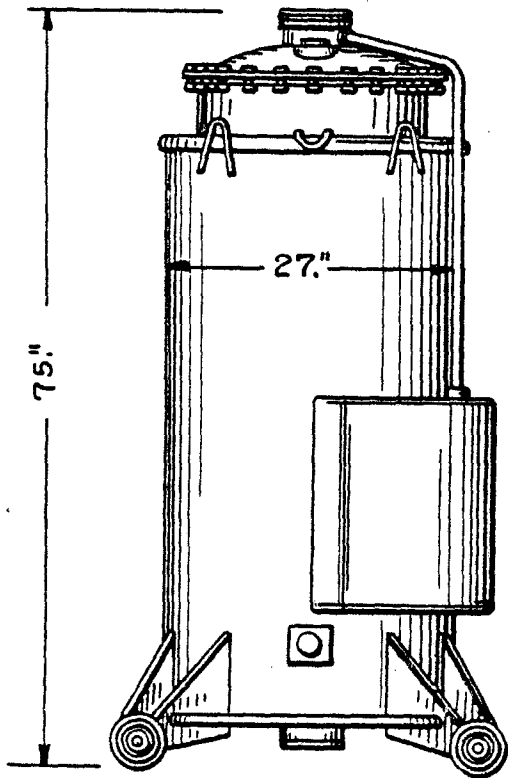

SIDE VIEW

TYPE-25

NO HORNS

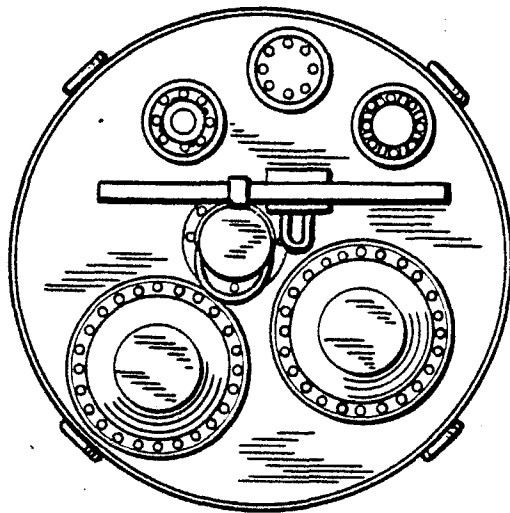

TOP VIEW

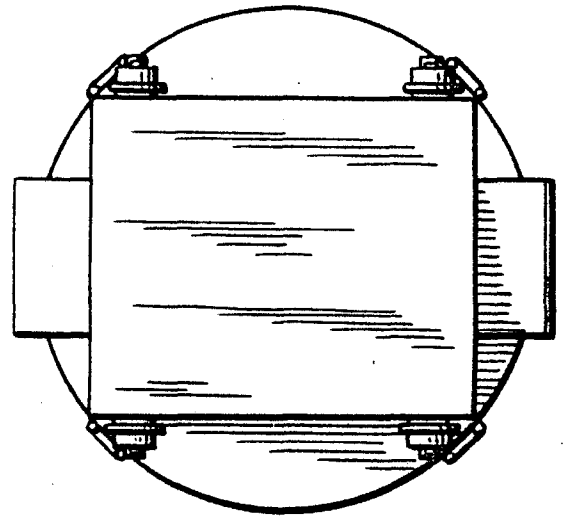

BOTTOM VIEW

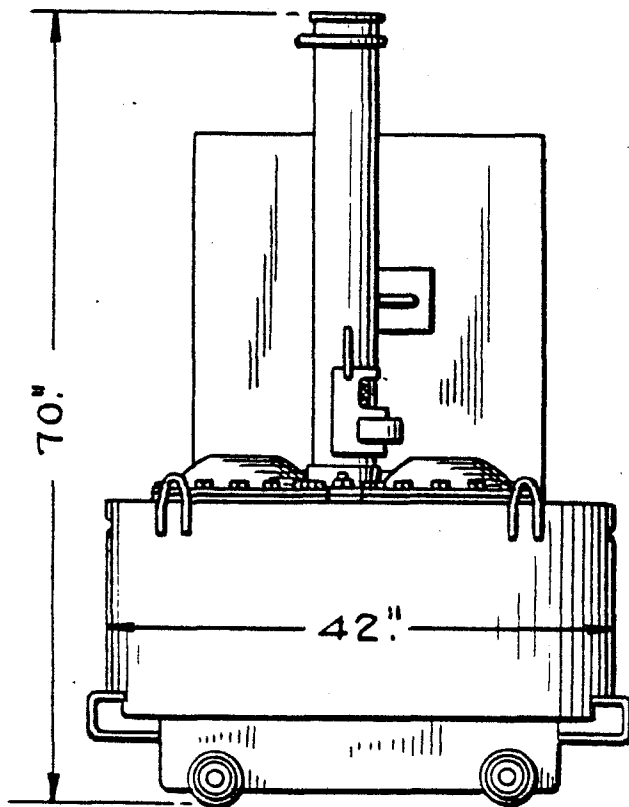

SIDE VIEW

TYPE-75
NO HORNS

DISTRIBUTION

Requests for copies of OP 898 (1st Rev.) should be addressed to the nearest BuOrd Publications Distribution Center:

Commandant and Superintendent
U. S. Naval Gun Factory, Navy
Yard
Washington 25, D. C.

Commandant
Navy Yard
Mare Island, Calif.

Commander Service Force, SEV-
ENTH FLEET
Ordnance Publications Subcenter,
c/o Fleet Post Office
San Francisco, Calif.

Officer in Charge
Ordnance Publications Subcenter
Naval Supply Depot
Pearl Harbor, T. H.

DISTRIBUTION:

Standard Navy Distribution List No.
17: 2 copies each unless otherwise noted.

1. b, c, i, k-q, s-u, w-hh, jj-11, nn, oo,
qq, ss-ww, yy; 1.(4 copies), g, h, j; 1.(6

copies), a; 1.(15 copies), d, e, r, ii, zz;
2.a-y, aa-dd, ff-jj; 3.; B3.(5 copies),
LIONS, CUBS, ACORNS; E3.; 4.;
5.a-e; 6.(10 copies), h; 6.(100 copies),
(for distribution to vessels other than
U. S. Naval Vessels), a-g, i-n; 7.d, i-l,
p, x; 7.(5 copies), f-h, q, s, aa; 7.(10
copies), a, b, c, r; 8.h(No. Beach only),
i, l, n(SPECIAL LIST L, Q, AA), x,
y; 8.(5 copies), n(SPECIAL LIST V),
n(10), q, r, v; 8.(10 copies), h(Exp.
Invest. Lab.), n(SPECIAL LIST P,
X), t; 8.(15 copies), j, n(SPECIAL
LIST K); 8.(25 copies), h(NOL); 8.(50
copies), n(SPECIAL LIST G Mine Dis-
posal School only), s; 8.(100 copies),
n(SPECIAL LIST G except Mine Dis-
posal School), 10.(10 copies), s(except
SanFran, New York and New Orleans);
10.(25 copies), nn; 10.(30 copies), s(New
Orleans only); 10.(50 copies), s(New
York and SanFran only); 11.(1 copy),
a(SecNav, Pub. Div.); 11.(5 copies),
a(BuShips, BuAer); 11.a(CNQ);
11.(500 copies), a(ComdtMarCorps);
12.b; 12.(6 copies), a; 14.(300 copies),
a; (15 copies), OCO, War Dept.