

DECLASSIFIED
Authority: NND 34869

RESTRICTED SECURITY INFORMATION

OP 1903

**BOMB MARK 77 MOD 0
(FIRE—750 LBS)**

DESCRIPTION AND INSTRUCTIONS FOR USE

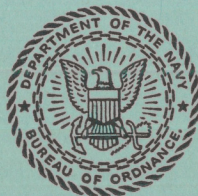

RESTRICTED SECURITY INFORMATION

A BUREAU OF ORDNANCE PUBLICATION

CONTENTS

<i>Chapter</i>		<i>Page</i>
1.	DESCRIPTION	1
	General Description	1
	Detailed Description	1
2.	INSTRUCTIONS FOR USE	6
	General	6
	Unpacking	6
	Assembly	6
	Filling	7
	Loading	7
	Fuzing	9
	Disassembly	9
	Repackaging	9
	Handling, Stowage, and Safety Precautions	11

RESTRICTED SECURITY INFORMATION

Reproduced from the Unclassified / Declassified Holdings of the National Archives

ILLUSTRATIONS

<i>Figure</i>		<i>Page</i>
1—Bomb Mk 77 Mod 0 (Fire—750 lbs) Suspended From Bomb Rack Mk 51	-----	vi
2—Bomb Mk 77 Mod 0 (Fire—750 lbs)	-----	2
3—Bomb Mk 77 Mod 0 (Fire—750 lbs) Packed in Bomb Crate Mk 7 Mod 0	-----	3
4—Igniter M15 with Fuze M157	-----	4
5—Igniter M16 with Fuze M157	-----	5
6—Igniter M23 with Fuze M173	-----	5
7—Tail Cone Assembly—Exploded View	-----	7
8—Bomb Sections, Gaskets, and Tie Rod—Exploded View	-----	8
9—Installation of Arming Wires	-----	9
10—Nose Cone Assembly with Igniter M15 and Igniter Adapter—Exploded View	-----	10
11—Nose Cone Assembly with Igniter M23—Exploded View	-----	10

RESTRICTED SECURITY INFORMATION



Figure 1.—Bomb Mk 77 Mod 0 (Fire—750 lbs) Suspended From Aircraft Bomb Rack Mk 51.

RESTRICTED SECURITY INFORMATION

Chapter 1

DESCRIPTION

General Description

Bomb Mk 77 Mod 0 (Fire—750 lbs), shown in figure 1, is a gasoline gel type bomb designed for low altitude bombing of personnel, wooden structures, land convoys, and flammable stores. It has standard suspension lugs (spaced 14 inches apart), and is reinforced to withstand the shocks of aircraft launchings and arrested landings.

As indicated in figure 2, the bomb's body consists principally of three sections: nose, center, and tail. These are held together by a tie rod. The gasoline gel that fills virtually the entire bomb, is ignited on impact by two air-armed fuzes, one located in the nose and the other in the tail. The fuzes are covered, respectively, by nose and tail cones. Upon the bomb's release from the plane, fuze arming is initiated, and the tail and nose cones are ejected simultaneously with removal of the arming wires.

Pertinent physical data of the bomb are:

Dimensions:

Length, 138.0 inches.

Diameter, 18.625 inches.

Weight:

Empty, 82 pounds.

Filled, 750 pounds.

Capacity:

Complete, 114 gallons.

Usable, 110 gallons.

For stowage or shipping, the bomb is disassembled and the nose and tail sections are nested into the center section, shown in figure 3. The tie rod is dismantled into two sections with the center nut, end nuts, washers and gaskets attached, and wrapped in waterproof paper and tape. The entire arrangement is packed in an open steel crate with all elements securely held in place.

Detail Description

Nose section. The nose section consists of an aluminum alloy body with a filler hole and cover, an aluminum alloy nose adapter, an igniter adapter, and a transparent plastic nose cone.

The nose section is cylindrical at the rear and tapers to a smaller diameter at the front. A filling hole at the top is closed by a screw-locked, gasket-sealed filler cover. The rear of the nose section is open and arranged to accommodate a ring-shaped gasket to seal the joint between the nose section and center section.

The front end of the nose section is closed by an aluminum alloy end plate casting welded to the nose section. The casting is circular with a bell extending into the nose section. The bell has an opening in the aft end to receive the tie rod during assembly. The forward portion of the casting is threaded to receive the igniter adapter, or the igniter if Igniter M23 is used. The casting has an integral bracket support at the top of the front side, with a drilled hole for a spring-loaded clevis pin that secures the nose cone adapter ring. At the bottom of the casting, a leaf spring is mounted that ejects the nose cone and its adapter when the clevis pin is removed.

A short aluminum tube, welded to the top of the rear portion of the section, and an internal tube are arranged to guide the arming wire and the nose release wire through the nose section and the end plate casting to the nose cone adapter clevis pin and igniter fuze.

The nose cone adapter is an aluminum alloy ring that mounts the plastic nose cone. It has three drilled holes for securing the plastic nose cone with screws and "J" nuts. The adapter is secured to the nose section end plate casting by pins at the bottom and a removable spring-loaded clevis pin at the top. The adapter is held in place until the clevis pin is released by removal of the arming wire when the bomb is dropped; then the



Figure 4.—Igniter M15 With Fuze M157.

The rear end is closed by an aluminum alloy end plate casting that is welded to the tail section. A filling hole at the top of the section is fitted with a cover identical to that of the nose section. A short piece of tubing is welded to the outside of the section, terminating just forward of a small hole in the section. A similar tube, welded to the inside of the section, extends from the small hole through the tail end plate casting. This arrangement provides a conduit for the arming and tail cone release wires that pass through the tail end plate casting.

The tail end plate casting is similar in detail

and function to the nose end plate casting, except for eight threaded screw holes spaced to mount tail fins* 90° apart.

The tail cone adapter is similar in appearance and function to the nose cone adapter, except that four slots are provided for possible future mounting of tail fins.

The tail cone is an aluminum alloy protective device similar to the nose cone in function and

*At time of publication, tail fins are not supplied as components of Bomb Mk 77 Mod 0 (Fire-750 lbs).

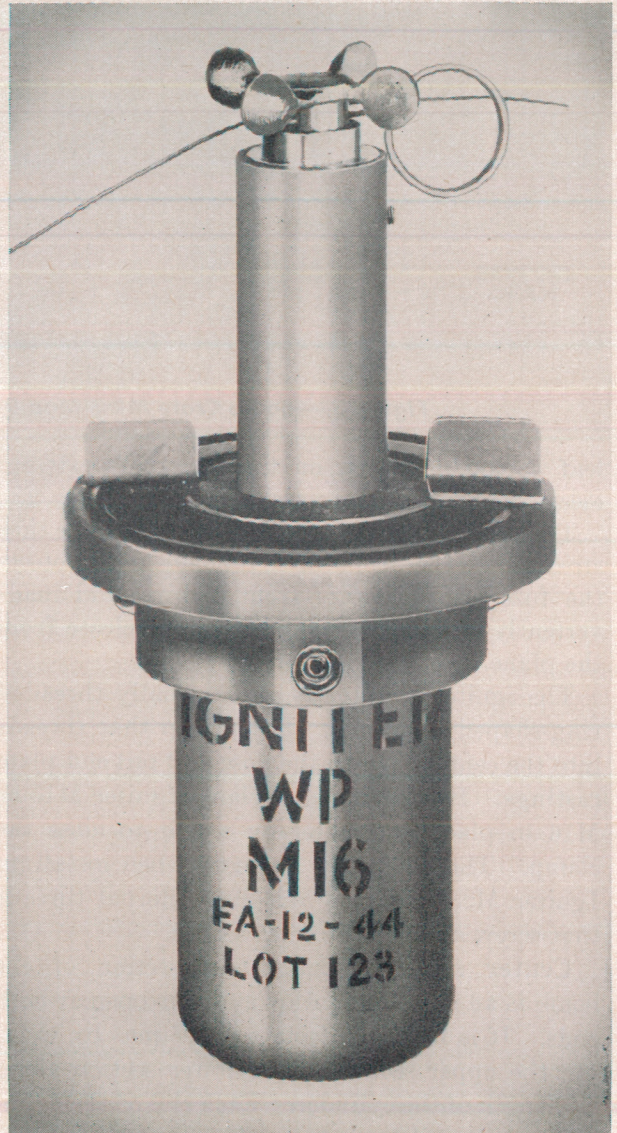

Figure 5.—Igniter M16 With Fuze M157.

method of assembly. It is, however, longer and more conical than the nose cone.

Gaskets. Two gaskets are provided to seal the abutting ends of the three bomb sections. They are identical rubber rings that fit into recesses at the rear of the nose section and the front of the tail sections. Each is circular, with a cross-section diameter of approximately 1/2 inch. When the bomb is packed for stowage or shipment, these sealing gaskets are maintained in the bomb recesses and are held secure by the ends of the packing crate.

Tie rod. The tie rod assembly consists of a self-locking nut, lock washers, flat washers, gaskets, forward tie rod, center nut, rear tie rod, and a special long nut. The forward tie rod is threaded at each end. The end with the shortest length of thread is passed through the nose end plate casting and secured by a self-locking nut, and the other end is screwed into the center nut. The rear tie rod also is threaded at each end. The end with the shortest length of thread is screwed into the center nut, and the other end is passed through the tail end plate casting and secured by a special long nut.

Igniters. There are three igniters that may be used with Fire Bomb Mk 77 Mod 0: the M15, M16, or the recently developed M23. The bomb is designed for the primary use of Igniter M23. Adapters are furnished with the bomb so that Igniter M15 may be used for either nose or tail fuzing, and Igniter M16 may be used only for tail



Figure 6.—Igniter M23 With Fuze M173.

fuzing. When the bomb is assembled, one igniter is attached to each end of the bomb and functions to ignite the gasoline gel within the bomb. Igniters M15, M16, and M23 are shown in figures 4, 5, and 6.

Chapter 2

INSTRUCTIONS FOR USE

General

This chapter sets forth procedures for unpacking, assembling, loading, filling, and arming the bomb. Instructions also are included for disassembly and repackaging of the bomb. For safety precautions to be observed during handling and stowage, and emergency actions to be taken to dispose of an armed bomb or in case of fire, refer to OP 1361.

The disassembled bomb components are shipped and issued in the metal Bomb Crate Mk 7 Mod 0 (LD 328478) shown in figure 3. The approximate dimensions of the crate are 20" x 20" x 86", and the weight of the crate and bomb as shipped is 138 pounds. Crated bombs will withstand a reasonable amount of rough handling and can be safely stacked to a height of 16 feet, without damage.

Unpacking. To unpack a crated bomb, refer to figure 3:

1. Remove eight screws in end of bomb shipping crate.
2. Remove end panel of crate.
3. Cut four metal straps securing bomb in crate.
4. Slide the bomb sections out of the open end of the crate.
5. Remove package containing arming wire.
6. Remove and open package containing the tie rods, washers, and nuts.
7. Remove tail cone from shipping crate end plate.
8. Make certain that sealing gaskets are in place and that sealing surfaces are free of foreign matter, dents, and nicks.
9. Verify that nose and tail sections include cones, cone adapters, shipping pins, igniter adapters, and filling hole covers.
10. Verify that suspension fittings on the center section are properly secured.

Assembly. Assemble the uncrated bomb in the following sequence (refer to figures 7 and 8):

1. Remove tail cone screws from tail cone adapter.
2. Pull shipping pin from clevis pin in tail cone adapter and remove clevis pin and clevis pin spring to release tail cone adapter.
3. Remove igniter adapter from tail end plate casting.
4. Remove nose cone.
5. Release nose cone adapter, following similar procedure as in step 2 above.
6. Remove igniter adapter from nose end plate casting.
7. Wipe gasket surfaces on all sections with carbon tetrachloride or gasoline.
8. Refer to figure 8. Assemble tie rod sections. Screw the ends of both the forward and rear tie rods, which have a one-inch length of thread, into the center nut until they bottom.
9. Pass that end of the tie rod assembly which has shortest length of thread through the nose section and through the hole in the nose end plate casting. Slide large inside diameter washer over end of tie rod and fit into recess; place gasket, small inside diameter flat washer, lock washer, and self-locking nut on the tie rod in that order. Secure by tightening self-locking nut on tie rod.
10. Pass tie rod assembly through center section.
11. Move tail section of bomb into position; remove rear filler cap; reaching through filling hole, guide tie rod through hole in tail end plate casting.
12. Slide large inside diameter washer over end of tie rod and fit into recess; place gasket, small inside diameter flat washer, lock washer, and long nut on the tie rod in that order, making certain the counterbored end of nut is placed over the tie rod first.
13. Align arming wire guide tubes on all sections.
14. Secure tie rod with the long nut and tighten with torque wrench to 425 inch-pounds.

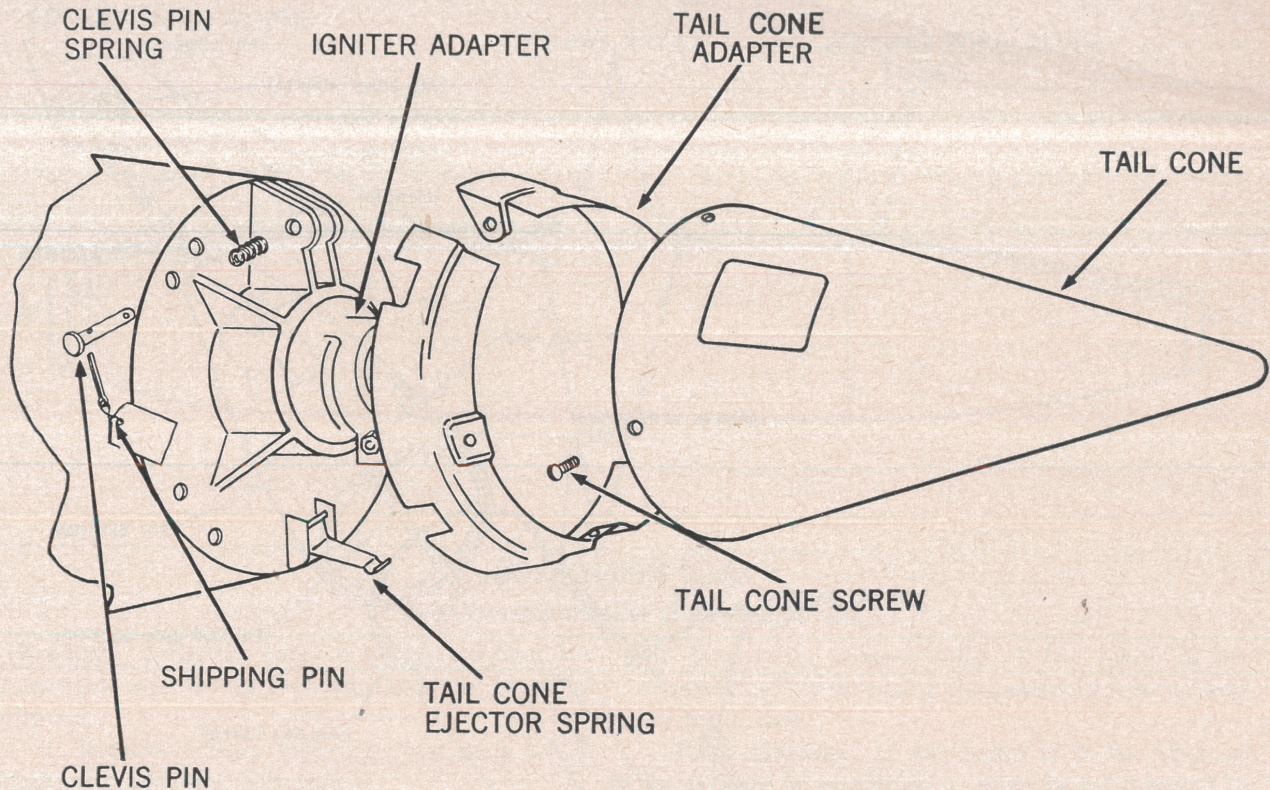

Figure 7.—Tail Cone Assembly, Exploded View.

CAUTION: Before tightening long nut, insure that gaskets on tie rod are properly seated.

15. Screw igniter adapter in nose end plate casting until it bottoms.

16. Replace nose cone adapter, clevis pin spring, and clevis pin. Replace shipping pin to secure assembly.

17. Verify that nose cone adapter release mechanism functions properly by pulling out shipping pin.

18. Reassemble nose cone adapter and assemble nose cone. Be careful NOT to damage nose cone by tightening screws excessively. If bomb is to be used immediately, nose cone need not be assembled to nose cone adapter until bomb is fuzed.

19. Screw igniter adapter in tail end plate casting until it bottoms.

20. Replace tail cone adapter, following similar procedure as in steps 16 through 18 above.

Filling. Detailed instructions for mixing the gasoline gel and filling the bomb are given in OP 1361.

Fill the bomb through either or both filling holes; both covers must be removed even though filling through only one hole. Make certain that both filling hole covers are secured after filling.

Note: The total capacity of the bomb is 114 gallons; however, never fill with more than 110 gallons. A minimum air space of 3 percent of bomb capacity is required.

Loading. This bomb was designed to be loaded on the aircraft while empty and then filled with gasoline gel. However, this procedure is not always practicable. A hoisting lug will be provided on later production of these bombs, for hoisting the filled bomb into position.

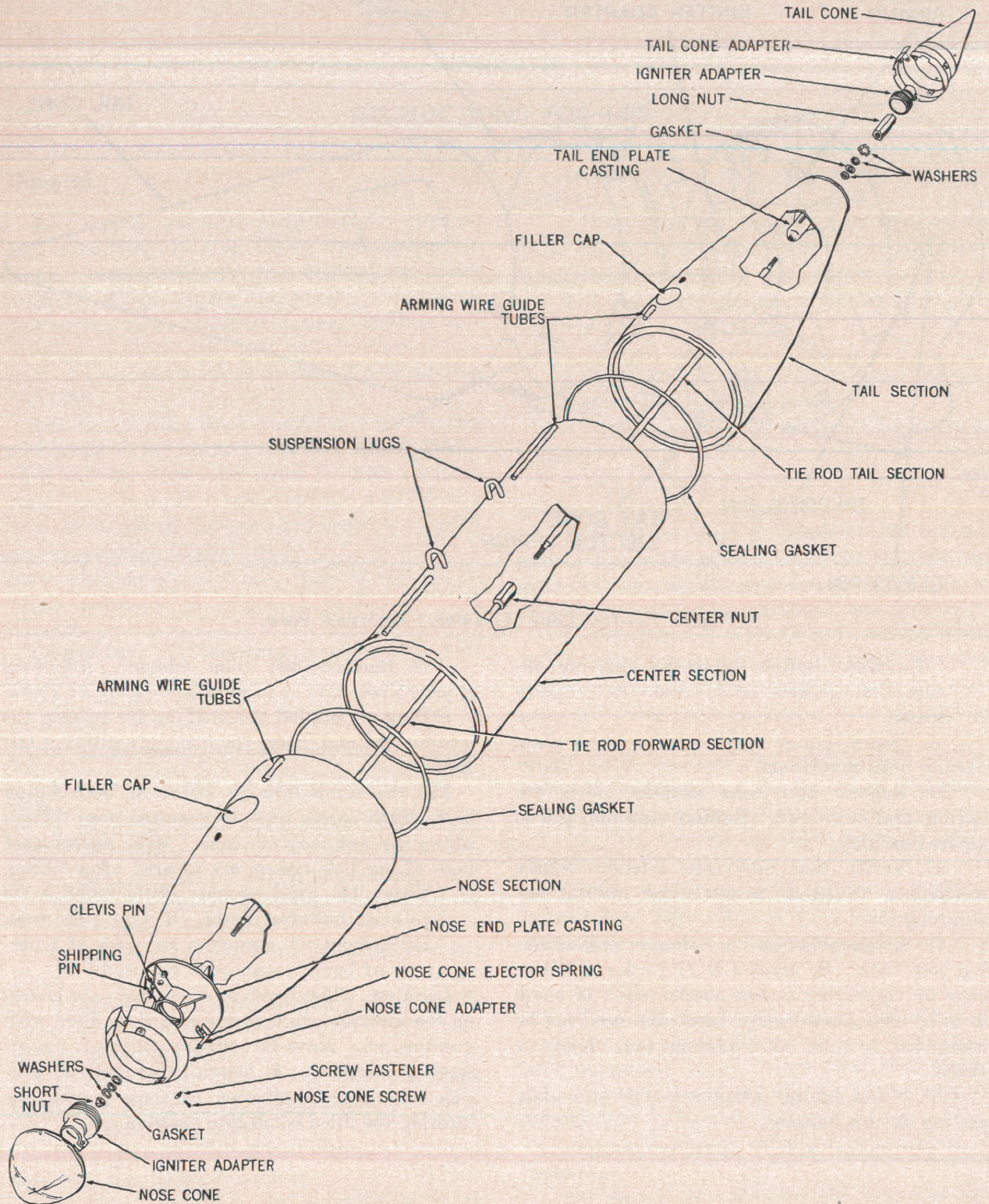

Figure 8.—Bomb Sections, Gaskets and Tie Rods, Exploded View.

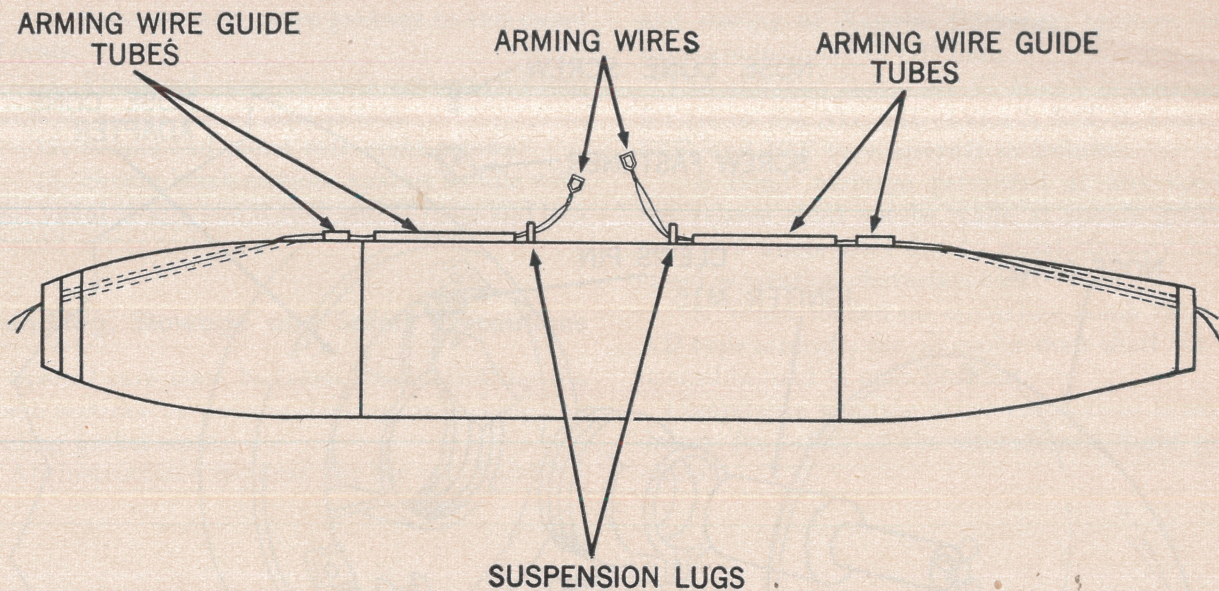

Figure 9.—Installation of Arming Wires.

Fuzing. After the bomb is suspended from the bomb rack and filled, fuze and arm the bomb as follows:

1. Remove screws securing nose cone to its adapter and remove nose cone.
2. Thread the two nose arming wires through suspension fitting and arming wire guide tubes.
3. Insert one wire through hole in end of clevis pin.
4. Attach arming wire to bomb rack.
5. Remove clevis pin shipping pin.
6. Repeat steps 2 through 5 to install rear arming wires.
7. Install nose and tail igniters.
 - a. Clamp Igniter M15 in igniter adapter in nose (figure 10) and Igniter M15 or M16 in igniter adapter in tail. Insure that the igniters bottom on the end plate castings before tightening the igniter clamps.
 - b. If Igniters M23 are used, unscrew igniter adapters and screw igniters into nose and tail end plate castings (figure 11).
8. Insert arming wires into the nose and tail fuzes.
9. Attach one Fahnestock clip to the ends of each igniter arming wire.
10. Remove safety pins from igniter fuzes.
11. Install nose and tail cones and secure with screws. Do not tighten screws excessively.

Disassembly. Only an unfilled bomb may be disassembled. Once filled, a bomb must be used

or destroyed. Disassembly of the bomb is accomplished by reversing the assembly instructions as applicable.

Repackaging. If the bomb is to be returned to stowage or reshipped, it must be repackaged in Bomb Crate Mk 7 Mod 0, exactly as received. To repackage:

1. Inspect the bomb crate to make certain that no members are bent or twisted.
2. Make certain that padding strips are in place on saddle in crate.
3. Secure tail cone to end panel of crate by two screws.
4. Place padding strips on gasket ends of nose and tail sections to bear on end panels of crate. Slide tail section, gasket end first, into crate.
5. Slide center section into crate, placing padding strips where contact is made with tail section.
6. Slide nose section into center section, nose first, placing padding strips where contact is made.
7. Lightly oil tie rod screw threads and partially assemble tie rod with self-locking nut, washers, gaskets, and center nut on forward section, and with long nut on rear section.
8. Wrap tie rod sections in anticorrosive paper JAN-B-121, Grade C, Type II, slide package into waterproof paper tubing JAN-P-125, and seal with waterproof tape AN-T-12A.
9. Secure tie rod package in crate in three places with wire.

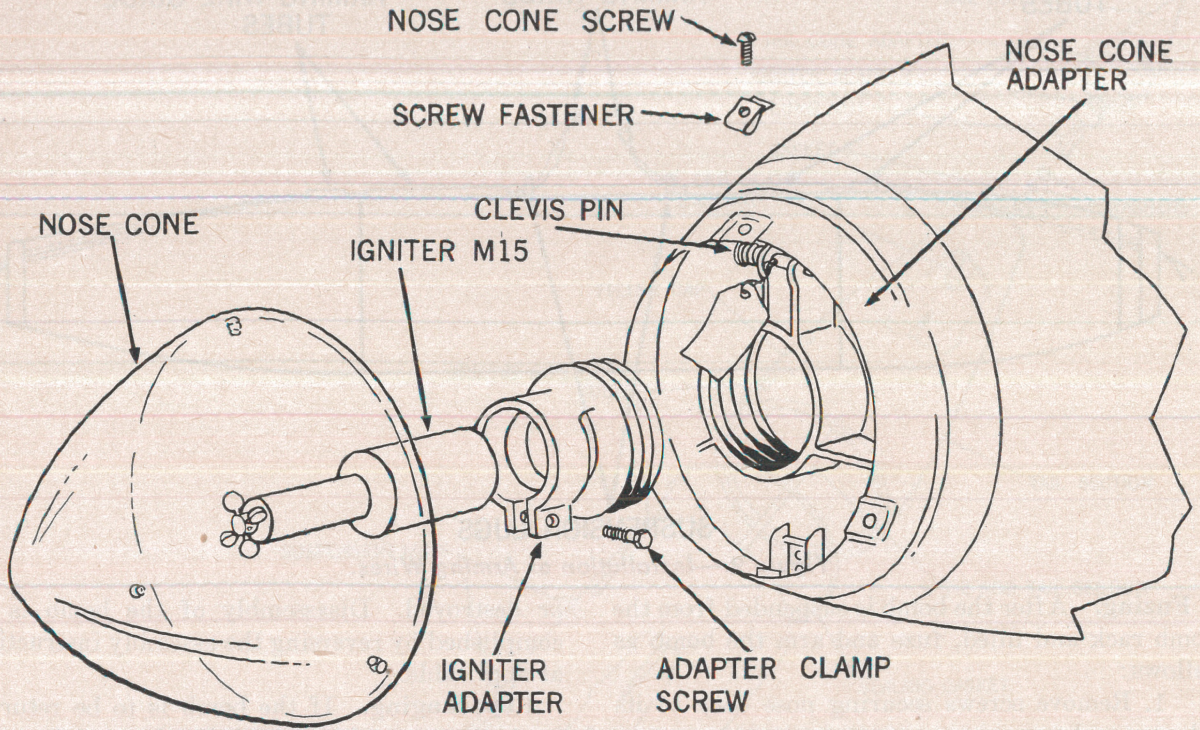

Figure 10.—Nose Cone Assembly With Igniter M15 and Igniter Adapter, Exploded View.

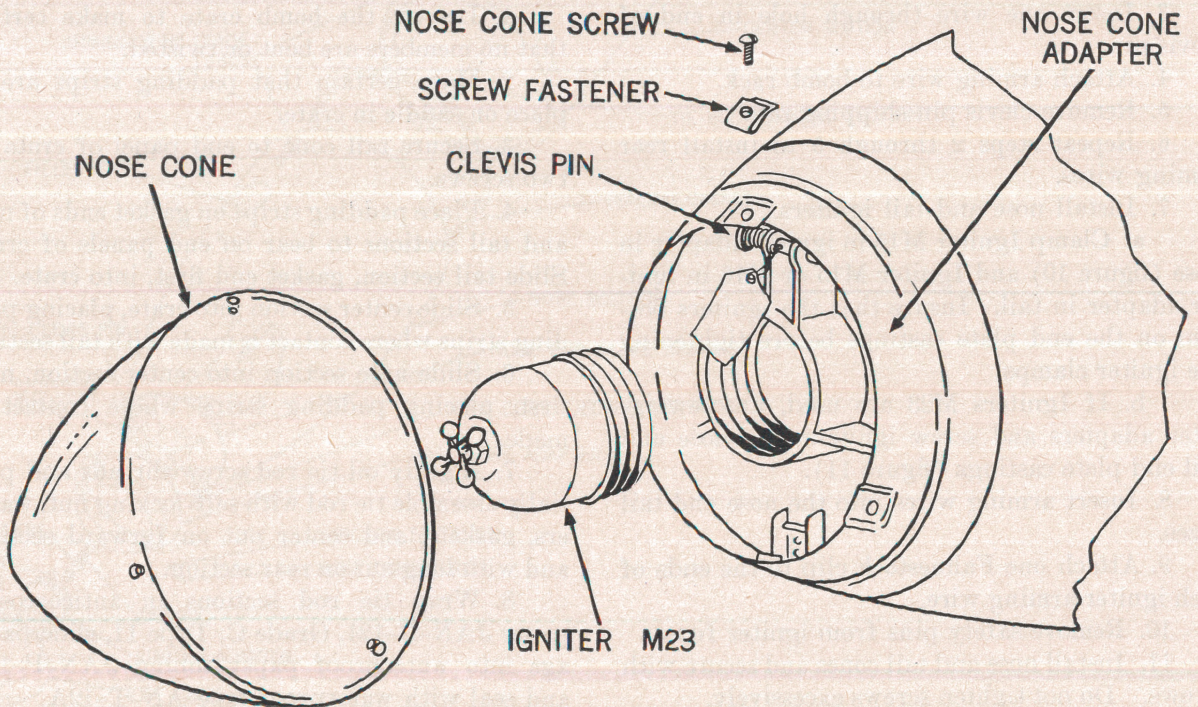

Figure 11.—Nose Cone Assembly With Igniter M23, Exploded View.

10. Secure arming wire package to end panel of crate.

11. Place end panel of crate against padding strips on gasket end of nose section.

12. Secure end panel with eight screws.

13. Secure bomb sections against saddle with four metal straps, one at each end of crate and two around center section.

Handling, Stowage and Safety Precautions

Special care must be taken when handling the bomb sections to prevent denting or nicking the sealing gasket seats.

All instructions required for the safe handling

and storing of Napalm thickener, igniters, and fuzes are included in OP 1361.

The unfinned Bomb Mk 77 Mod 0 is restricted for use on the AD, F4U-4 and 5, F9F-2, 4 and 5, F7F, and F8F type aircraft as follows:

1. Bomb carriage permitted at any speed, but release shall not be made at speeds greater than 375 knots IAS due to unsatisfactory high speed separation characteristics.

2. When loaded on centerline bomb rack of AD type aircraft, the oil cooler door shall not be opened beyond 1/4 open position.

Compliance with the above restrictions is mandatory for safety of the aircraft and flight personnel.