

FOR OFFICIAL USE ONLY

OP 1793

2.75 FOLDING-FIN AIRCRAFT ROCKET

DESCRIPTION AND INSTRUCTIONS FOR USE



A BUREAU OF ORDNANCE PUBLICATION

FOR OFFICIAL USE ONLY

OP 1793

2.75 FOLDING-FIN AIRCRAFT ROCKET

DESCRIPTION AND INSTRUCTIONS FOR USE



14 SEPTEMBER 1954



DEPARTMENT OF THE NAVY
BUREAU OF ORDNANCE
WASHINGTON 25, D. C.

14 September 1954

ORDNANCE PAMPHLET 1793

2"75 FOLDING-FIN AIRCRAFT ROCKET; DESCRIPTION AND INSTRUCTIONS FOR USE

1. Ordnance Pamphlet 1793 describes the 2"75 Folding-Fin Aircraft Rocket, and provides instruction for its use, operation, and storage.
2. This publication is intended for use by all personnel concerned with the operation of the 2"75 Folding-Fin Aircraft Rocket.
3. This publication does not supersede any existing publication.
4. This publication is for Official Use Only.

M. F. SCHOEFFEL

A handwritten signature in black ink, reading "F. S. Withington". The signature is written in a cursive style.

F. S. WITHINGTON
Rear Admiral, U. S. Navy
Deputy Chief, Bureau of Ordnance

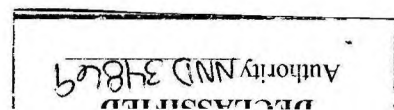

CONTENTS

<i>Chapter</i>	<i>Page</i>
1. INTRODUCTION.....	1
General Description.....	1
2. DETAILED DESCRIPTION.....	2
Fuze.....	2
Head.....	2
Motor Assembly.....	2
3. OPERATION.....	7
Ignition.....	7
Fin Operation.....	7
Arming.....	8
Detonation.....	8
4. HANDLING AND STORAGE.....	9
Shipping.....	9
Assembly.....	9
Ready-Service Storage.....	10
Loading the Launcher.....	10
Removing Rocket from Launcher.....	11
Disassembly and Storage.....	11
Handling Defective Parts.....	11
SAFETY PRECAUTIONS.....	12

ILLUSTRATIONS

<i>Figure</i>	<i>Page</i>
1—2"75 Folding-Fin Aircraft Rocket, Complete Round with Fins Extended.....	iv
2—Exploded View of Head and Forward End of Motor.....	2
3—Nozzle-Fin Assembly and After End of Motor. Propellant Grain Partially Pulled out of Motor Tubes.....	3
4—Nozzle-Fin Assembly, Fins Closed.....	4
5—After View of Fins, Showing Crosshead.....	5
6—Phases of Fin Operation.....	6
7—Changes in Position of Fins at Various Distances of Rocket from Launcher. Last Photo Shows Fins in Final Position.....	7
8—Fin Protector in Place.....	9

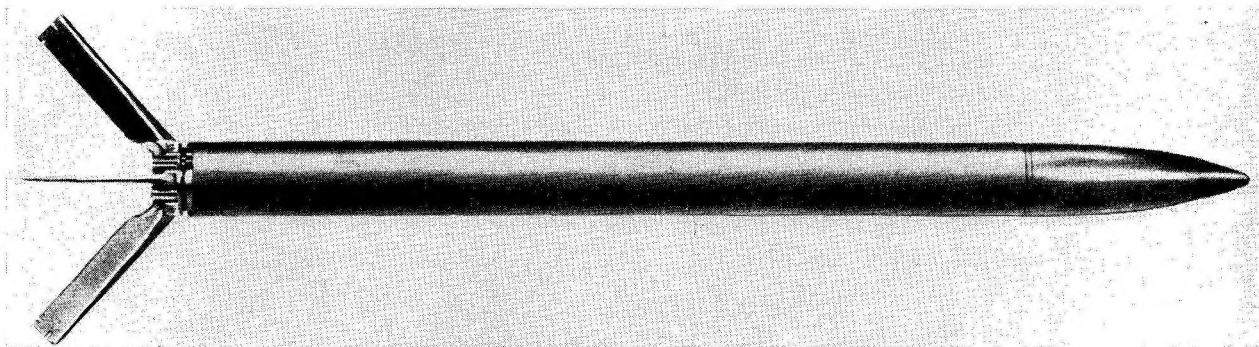

Figure 1—2.75 Folding-Fin Aircraft Rocket, Complete Round with Fins Extended.

DECLASSIFIED
Authority NND 34869

Chapter 1

INTRODUCTION

The 2.75 Folding-Fin Aircraft Rocket (FFAR), figure 1, is an air-to-air projectile developed to provide efficient armament for modern high-speed fighter and interceptor aircraft.

The rocket is composed basically of Fuse Mk 176 which has a delay element or Fuze Mk 178 which does not have a delay element, an ogival steel head threaded internally at the forward end for attachment of the fuze and externally at the after end for attachment of the motor, and a motor assembly.

General Description

For air-to-air firing, the rocket is designed to make direct hits, penetrate the outer skin of an aircraft, and then detonate within the aircraft structure. This intended operation of the rocket is based on tests which established that aircraft are more vulnerable to internal explosions.

In keeping with the intended operation, the rocket is designed with a steel head, which remains intact after striking and penetrating an aircraft, and which is fitted with a point detonating fuze incorporating a delay element. The delay allows the head of the rocket to penetrate an aircraft structure before detonating.

Although originally designed for air-to-air use, the 2.75 FFAR has proved to be a potent air-to-ground weapon against a wide variety of targets. For air-to-ground firing, the FFAR usually is equipped with a nondelay fuze.

At present Mk 1 and Mk 5 heads are issued for use with the 2.75 FFAR. An explanation stencilled on the head designates the type of filler (inert or explosive (HBX)).

Explosive loaded heads are painted olive drab, inert loaded heads are painted light blue, and heads for dummy (drill) round are painted black. Inert loaded heads are issued with a dummy nose fuze.

Explosive loaded Mk 1 heads may be issued with either Fuze Mk 176 which has a delay element, or Fuze Mk 178 which is a point-detonating (PD) fuze.

Other heads designed for use with this rocket are Mk 5 High-Explosive Anti-Tank (HEAT) with Fuze Mk 181, and Mk 3 and Mk 4 which are slug-type armor-piercing. The difference in construction of the latter two is that Mk 4 has a wind-screen.

Currently three motors are used with the 2.75 FFAR: Mk 1 Mods 3 or 4, Mk 2 All Mods, Mk 3 All Mods. Motors Mk 1 Mod 0, Mk 1 Mod 1, and Mk 1 Mod 2 never were issued for service use. The Mk 2 All Mods incorporate a new propellant, while the Mk 3 All Mods add a flash suppressor.

The 2.75 motor has fins that fold within the 2.75-inch diameter of the rocket, which permits the FFAR to be fired from tubular launchers.

Heads for the FFAR can be attached to motors without special tools. The loaded motor without head assembled is nonpropulsive which eliminates danger in case of accidental ignition, and can be stored at moderate temperatures for reasonably long periods of time without deterioration.

Trajectory tables for the FFAR are in OP 1998. Physical characteristics of the rocket are the following:

Length, over-all (fins folded), inches-----	48
Diameter, inches-----	2.75
Approximate weight, pounds:	
Round before firing-----	18.1
Loaded and fuzed head-----	6.5
CG of round (from nose), inches-----	19.4
Service temperature limits, °F-----	* -65 to 150

** Although these limits are standard, they do not necessarily apply to all motors. Observe temperature limits on specific motor tubes.*

Chapter 2

DETAILED DESCRIPTION

Fuze

Fuze Mk 178 (PD) is very similar to Fuze Mk 176. Both fuzes screw into the nose of the high-explosive head, both are hermetically sealed, both arm in the same manner and have nearly identical explosive trains. The main difference between the two fuzes is the absence of a delay element in Fuze Mk 178.

Fuze body. The cone-shaped steel fuze body is $2\frac{3}{4}$ inches long. It encloses the firing mechanism, arming mechanism, primer, delay element, detonator, and booster. It is threaded at the lower end for attachment to the head.

Arming Mechanism. In the unarmed condition, the rotor of the arming mechanism is positioned and locked so that the primer and detonator are out of alignment with the firing pin and booster lead-in, respectively. Thus, the arming mechanism is "detonator safe"; that is, accidental operation of the unarmed firing mechanism will not set off the primer and detonator because the firing pin cannot engage or initiate the primer until the rotor is in its armed position.

No arming wire is required for the fuze, and the arming mechanism is hermetically sealed in the fuze body.

Head

The head, figure 2, is an ogival steel case threaded internally at the forward end for attach-

ment of the fuze and externally at the after end for attachment of the motor. The head is loaded with either a high-explosive charge or an inert load of plaster. A threaded, cup-shaped cavity liner is screwed into the nose end of the loaded head and seats on the forward face of the explosive filler. This liner prevents exposure of the filler when either the shipping plug or the fuze is removed. NEVER remove fuze cavity liner. The explosive loaded heads, as well as the inert-loaded, dummy-fuzed heads, are designated Mk 1 All Mods. The difference between the several mods is only in minor construction details.

Motor Assembly

The motor tube is made of seamless aluminum-alloy tubing 0.072-inch thick. It is 32 inches long and $2\frac{3}{4}$ inches in outside diameter. The forward end of the tube has an internal groove to provide lockwire attachment for the head closure; the after end has a similar groove for lockwire attachment of the nozzle-fin assembly.

Head closure. The cup-shaped steel head closure, figure 2, is about $2\frac{1}{2}$ inches long and $2\frac{1}{2}$ inches in diameter. The closure fits into the motor tube with the open end facing forward. It is attached to the tube by a lockwire fitted through a slot in the tube into mating grooves located on the inside of the motor tube and the outside of the sleeve portion of the closure. The

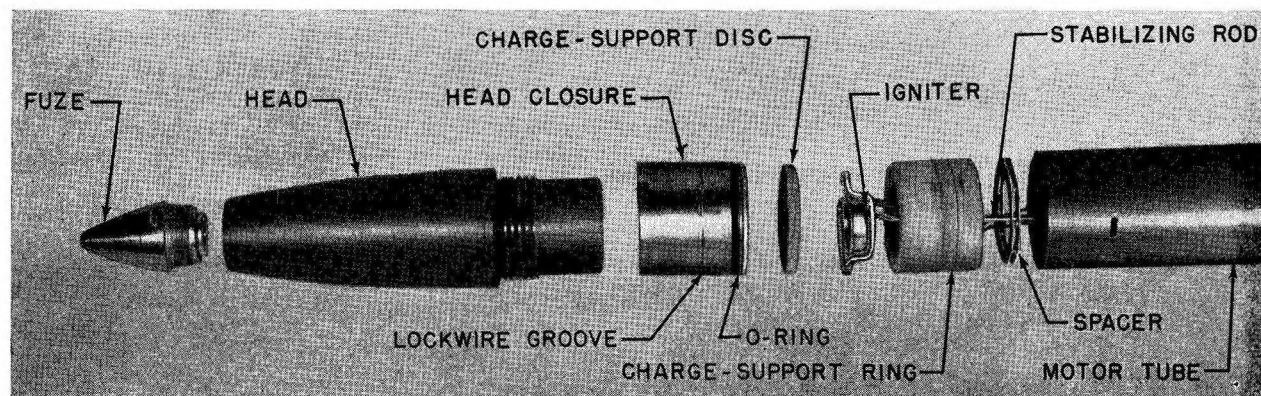

Figure 2—Exploded View of Head and Forward End of Motor.

DETAILED DESCRIPTION

after end of this sleeve has an external groove fitted with a rubber O-ring seal that prevents the escape of gas from the motor tube during burning and serves as an atmospheric seal during storage.

The bottom (after end) of the head closure is a thin disc that functions as a blowout diaphragm to relieve gas pressure in case of accidental ignition of the motor during shipping or storage (prior to assembly of the head with the motor). The interior of the head closure is threaded with stub Acme threads for attachment of the rocket head.

Propellant. The propellant used in the 2.75 Rocket Motor Mk 1, Mk 2, and Mk 3 is an internal-burning grain of ballistite. The external surfaces of the grain are covered with a plastic inhibiting material which prevents the grain from burning on the outside but does not affect its internal burning.

End Sleeve. A cylindrical end sleeve, figure 3, is bonded to the end inhibitor at the after end of the propellant charge. A rubber seal ring fits over the sleeve. The seal ring prevents leakage of gas along the annular space between the exterior surface of the propellant charge and the inner surface of the motor tube, thus preventing

overheating of the aluminum tube. The rubber seal ring also cushions the charge against acceleration forces.

Charge-Support Ring. The charge-support ring, figure 2, is a resilient hollow cylinder of glass fiber located at the forward end of the charge. This ring has a dual function. It provides spring action that keeps the charge firmly supported in the motor tube, and it acts as a shock absorber for the charge if the motor (or round) is dropped.

Charge-Support Disc. The charge-support disc, figure 2, is a cushion of glass fiber between the igniter and the base of the head closure.

Spacer. The spacer, figure 2, is a double steel ring about 2½ inches in diameter, located between the charge-support ring and the forward end of the propellant grain.

Igniter. The igniter, figure 2, is a thin-walled tin can about ½ inch in length and 1½ inches in diameter. It has a blowout plug in its after face and is filled with a mixture of black powder and magnesium powder. An electric squib containing wire bridge imbedded in an ignition compound initiates the igniter. Two lead wires from the igniter pass aft through the perforation of the grain to the nozzle-fin assembly, where one wire

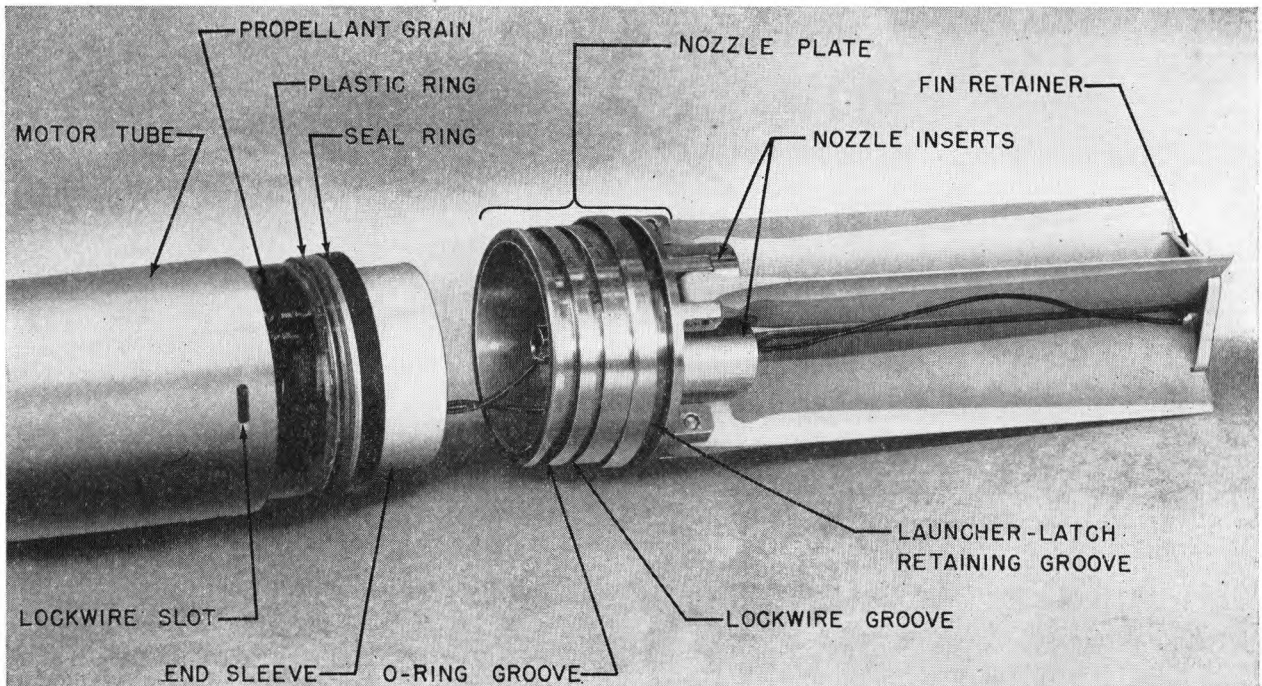

Figure 3—Nozzle-Fin Assembly and After End of Motor. Propellant Grain Partially Pulled Out of Motor Tube.

is grounded to the nozzle plate and the other leads aft through an insulated conductor in one of the sealed nozzles to an insulated firing-contact disc at the after end of the fins. Only the nozzle plate can be relied upon for definite ground circuit contact. Anodizing and painting the rest of the outside of the rocket to prevent corrosion, prohibits the use of these parts as ground circuit contacts.

Nozzle-Fin Assembly. The nozzle-fin assembly, figures 3 and 4, which attaches to the after end of the motor tube, consists basically of a nozzle plate, four nozzle inserts, a fin-actuating mechanism, four fins, and a fin retainer and contact disc.

NOZZLE PLATE. The cup-shaped steel nozzle plate is about $1\frac{1}{2}$ inches long and $2\frac{3}{4}$ inches in diameter. In its base, or after end, are four steel nozzle inserts and a central fin-actuating cylinder. The nozzle inserts are fitted with thin, steel cups which are cemented into the exit cones of the nozzles to act as seals. These nozzle seals contribute to the total sealing of the motor chamber.

Like the head closure, the nozzle plate has a sleeve on which there are two external grooves—

one for an O-ring seal and another, aft of the O-ring groove, for lockwire attachment of the assembly to the motor tube. In addition, this sleeve has a third and larger external groove, the launcher-latch retaining groove, by which a round is held in its proper position after it is loaded into a launcher.

FIN ACTUATING MECHANISM. The fin-actuating mechanism consists of a steel cylinder and a piston with a crosshead attached to its after end, figures 5 and 6. Gas pressure from the motor operates the piston and crosshead, pushing the crosshead against the heels of the fins and thereby causing the fins to open.

FINS. The fins are shaped aluminum-alloy plates $6\frac{1}{2}$ inches long and $1\frac{1}{4}$ inches wide. They taper uniformly in thickness from base to tip, and are bevelled on both edges. The fins are attached by pivot pins to lugs machined on the after part of the nozzle plate. When folded, figure 4, they lie within the 2.75-inch diameter of the round. The fins are notched at the tips to allow attachment of a fin retainer, and are

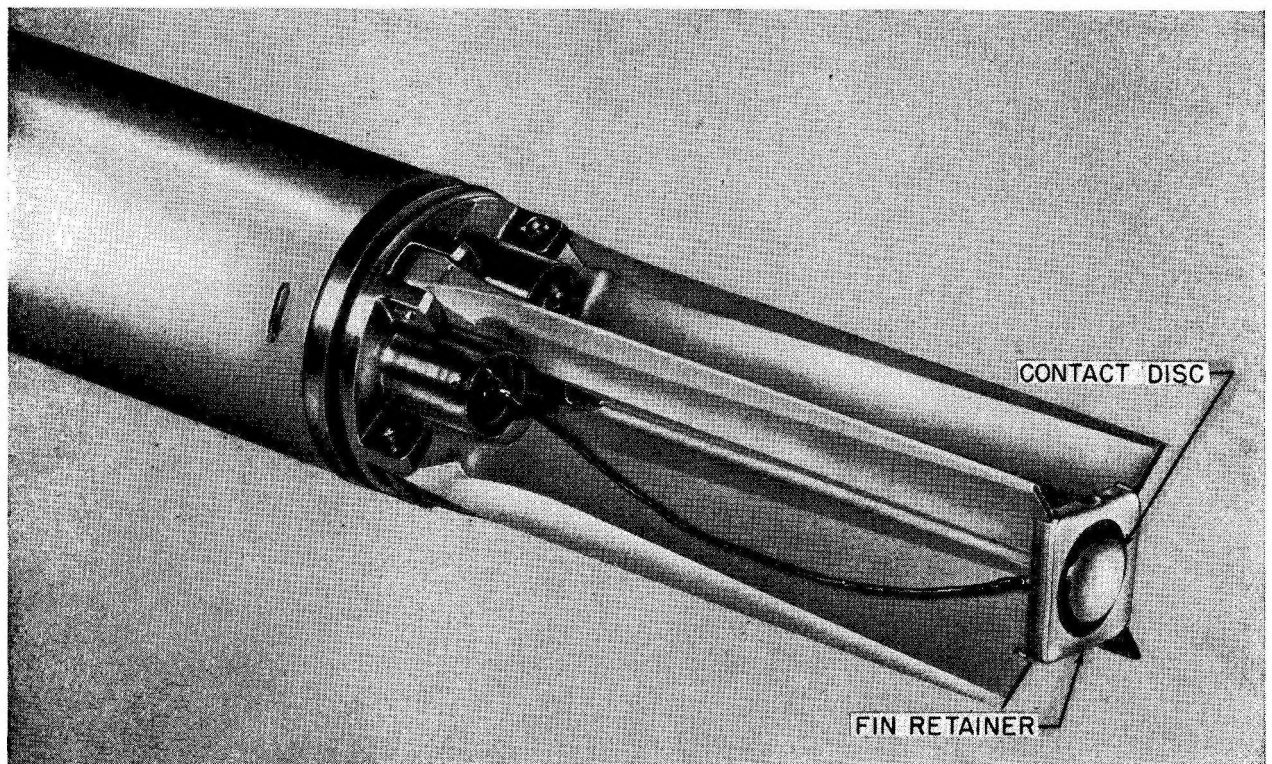

Figure 4—Nozzle-Fin Assembly, Fins Closed.

notched on their inner edges near the tip to allow engagement with a retainer stud of plastic. The inside forward corners of the fins are bevelled so that the fins will clear the nozzle blast when they are open.

FIN RETAINER. The fin retainer, figure 4, is a 1½-inch square aluminum frame which engages

the notches in the tips of the fins and holds the fins in the folded position. The retainer is fitted with an insulated cadmium-plated brass contact disc which connects to the igniter lead wire. Attached to the fin retainer is a stud which engages the notches on the inner edges of the folded fins and holds the retainer in place.

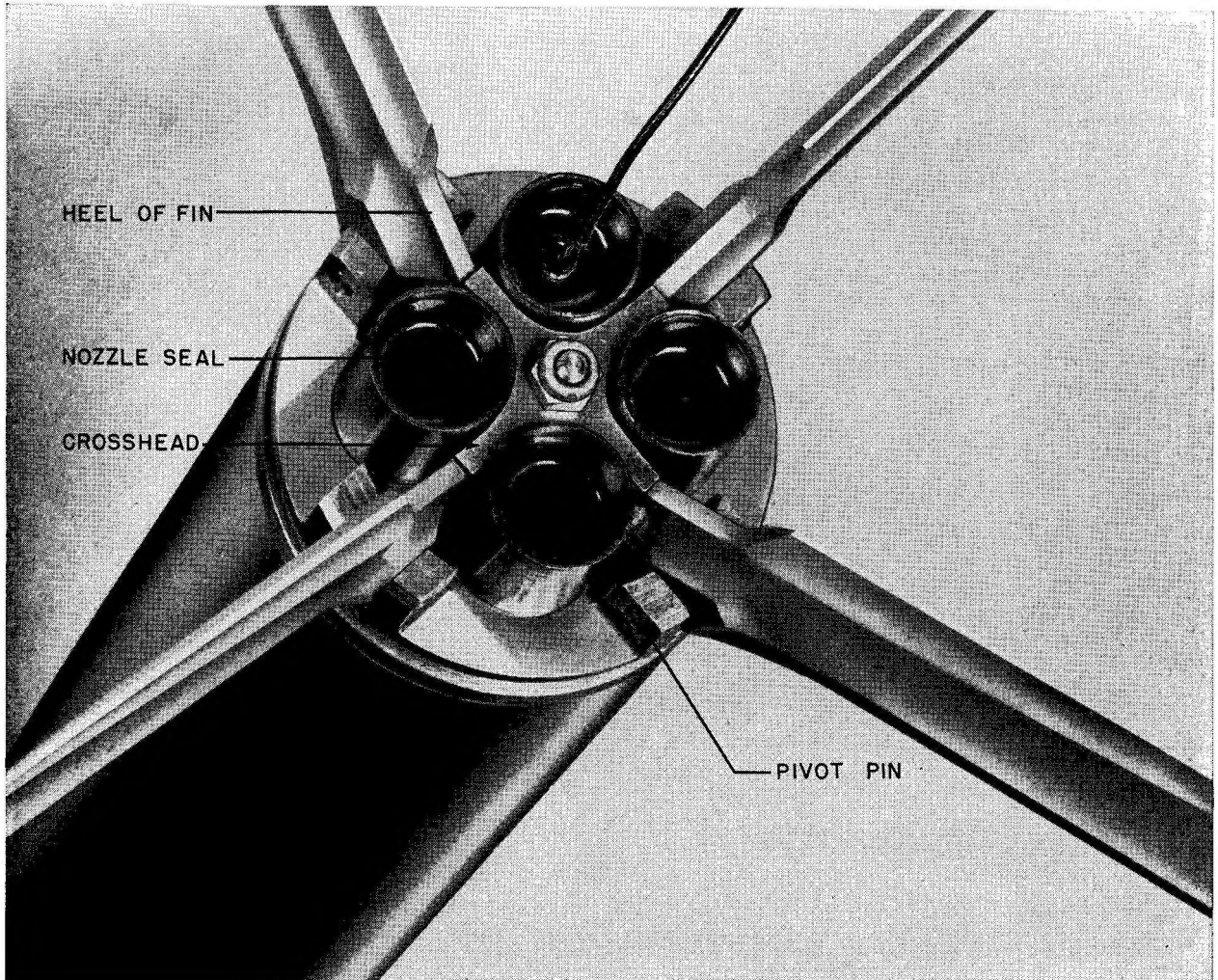
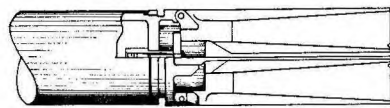
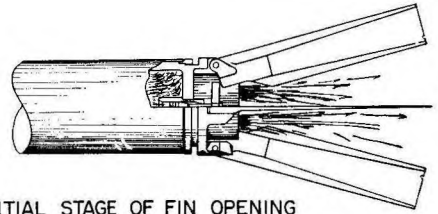

Figure 5—After View of Fins, Showing Crosshead.



POSITION BEFORE FIRING



INITIAL STAGE OF FIN OPENING

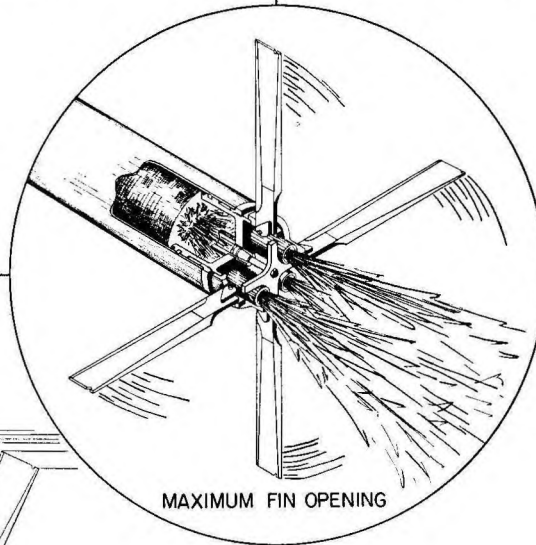

MAXIMUM FIN OPENING

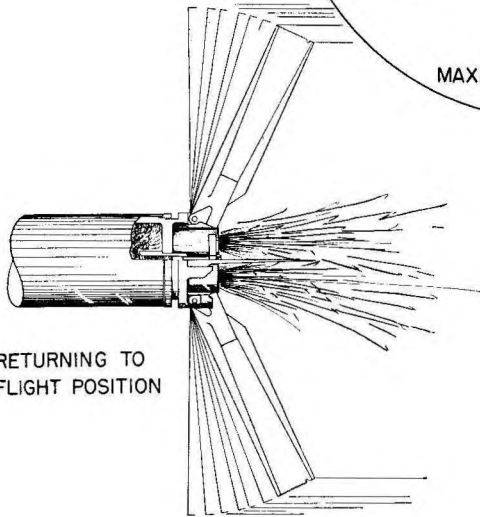

RETURNING TO FLIGHT POSITION

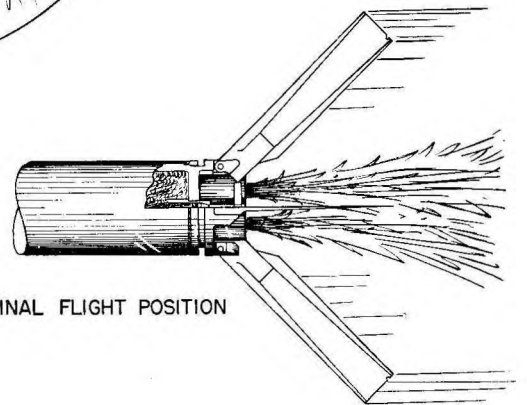

FINAL FLIGHT POSITION

Figure 6—Phases of Fin Operation.

DECLASSIFIED
Authority NND 348629

Chapter 3

OPERATION

Ignition

When the switch in the launcher firing circuit is closed, the current passes from the firing contact in the launcher through the insulated contact disc at the rear of the rocket and along the lead wire to the squib in the igniter. Then it passes back via the ground wire to the nozzle latch, where it is grounded through the launcher latch.

A minimum firing current per round of 1.5 amperes for 10 milliseconds is required; the recommended firing current per round is 3 amperes. If the current drops below 1.5 amperes, increases in the ignition delay may be expected; and if the current drops below one ampere, a very long period of ignition delay may be expected. The loaded igniter has a resistance of 0.5 to 1.3 ohms.

Current entering the squib heats the bridge wire, setting off the squib primer mixture which ignites the igniter charge. Pressure within the igniter unseats a blowout plug, permitting the burning igniter charge to ignite the propellant grain. The whole process of ignition requires about 0.03

second. Pressure of the hot propellant gases from the burning grain bursts the nozzle seals and provides the thrust that propels the rocket.

Fin Operation

When the motor is fired, figures 6 and 7, the fin retainer, together with the contact disc and other associated parts, are blown off by the blast from the nozzles. Gas pressure from the motor forces the fin-actuating piston and crosshead aft, pushing the crosshead against the heels of the fins. While in the launching tube, the fins are constrained and exert a force of approximately 2 pounds per blade against the tube.

As soon as the round clears the launcher, the crosshead forces each fin open to an angle of slightly less than 90 degrees with the axis of the motor tube. Aerodynamic drag and setback forces return the fins to an angle of 45 degrees, figure 7, in which position the heels of the fins rest against the fully extended crosshead. The crosshead locks in this position so that the fins retain their 45 degree angle throughout the flight of the rocket.

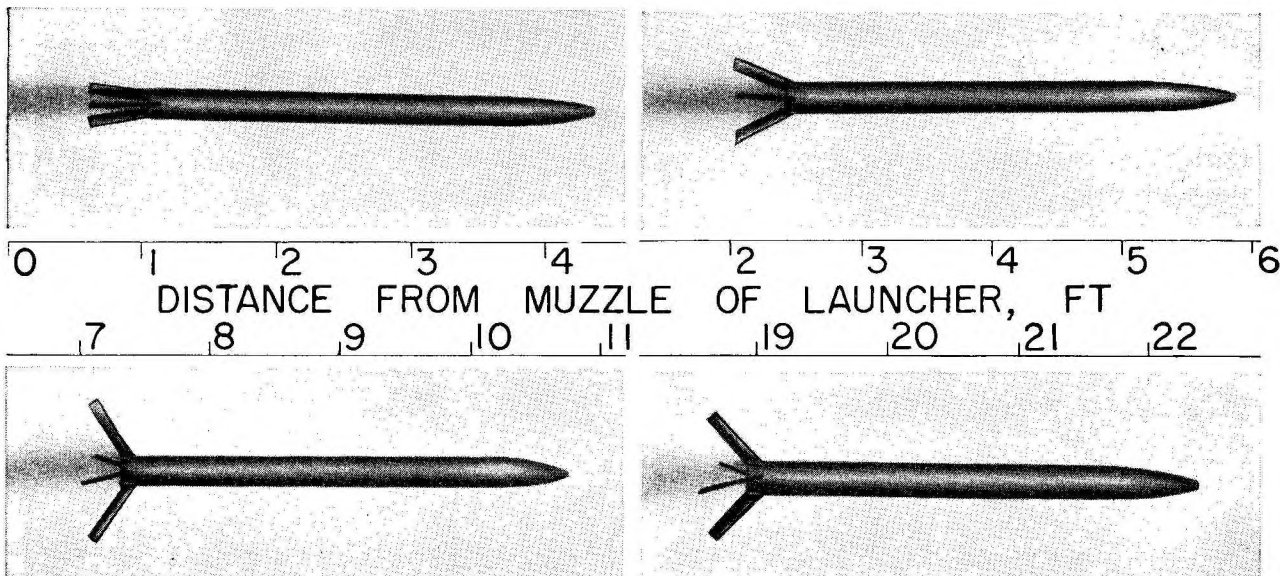

Figure 7—Changes in Position of Fins at Various Distances of Rocket from Launcher. Last Photo Shows Fins in Position.

Arming

Sustained acceleration of the fired rocket overcomes the force of the springs which retain the setback weight of the fuze arming mechanism, thus allowing the weight to travel aft and free the rotor. The acceleration also causes the eccentrically weighted rotor to rotate until the primer and detonator are aligned with the firing pin and booster, respectively. There the rotor is locked in position by a spring-actuated detent.

The rate of rotation of the rotor is governed by the geared escapement, which insures that the rocket will travel at least 400 feet before the fuze will arm. The maximum distance allowed for arming is approximately 1400 feet. These distances are for rockets which are ground launched.

The fuze is detonator-safe; that is, it cannot be detonated until armed by the acceleration of firing.

Because of its construction, the fuze will not arm as a result of transient accelerations caused by rough handling, dropping, or catapult launching.

Detonation

Upon striking a target, the thin nose section of the fuze body directly forward of the rotor housing is pushed inward. This thrusts the hammer and firing pin aft and forces the firing pin through the anti-setback washer and the hole in the closing nut into the primer, which detonates. Detonation of the primer sets off, in turn, the delay element, the detonator, the booster lead-in, the booster, and the explosive charge in the head.

The primary destructive effect of the head results from its blast. Additional damage, however, may result from fragmentation of the steel head and the motor tube.

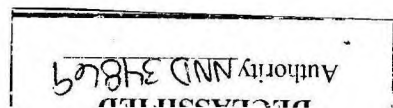

Chapter 4

HANDLING AND STORAGE

Shipping

Complete but not fully assembled rounds are shipped four to a 2"75 Rocket Container Mk 1 Mod 0 for protection during transit and storage. The fuze is attached to the head, but the head is not screwed into the motor. Instead, the head is placed in a reversed position so that the fuze rests slightly within a head shipping support set within the head closure of the motor tube. The threads at the base of the head are covered with light grease for protection against corrosion. Also, motors may be shipped in combination launcher-shipping containers, such as the Aero 6A, with fuzed heads in a separate container.

The fins are covered by a fin protector, figure 8, which is an elongated steel can. A conical-coiled steel spring, riveted to the center of the base inside the fin protector, makes contact with the insulated contact disc at the after end of the fins, shorting out the igniter firing circuit to prevent accidental firing of a motor during transit and storage.

Assembly

Observe standard safety precautions throughout the assembly and loading operation.

WARNING

Only essential personnel may be in the vicinity of assembly and loading operations.

NO SMOKING within 200 feet of rocket ammunition.

Before loading, check the following:

Main Battery Switch—OFF (External power source NOT connected).

Armament Master Switch—OFF.

Individual Armament Switches—OFF.

Check firing circuit instructions for stray voltage.

Safety Plug—OUT (Displayed in plain sight).

Assembly of the 2"75 Rocket in the field requires only the attaching of the fuzed head to the motor.

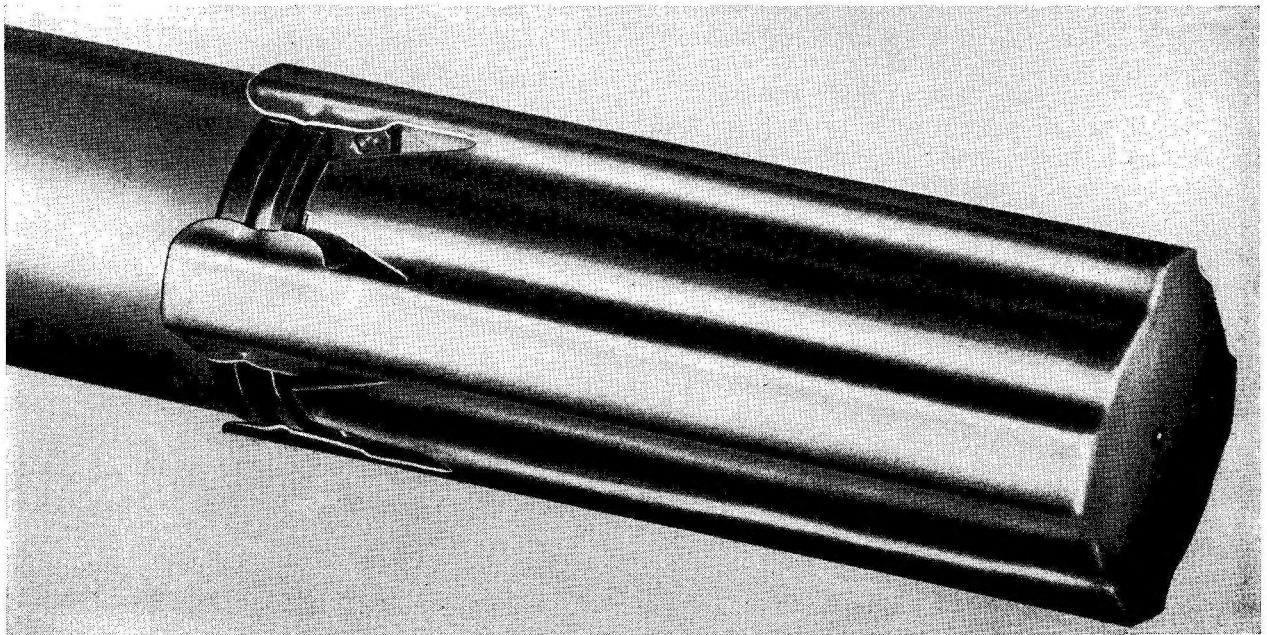

Figure 8—Fin Protector in Place.

When issued in the four-round Mk 1 Container, the nose end of the head is seated in a head shipping support in the forward end of the motor. Remove the head and head shipping support from the motor and screw the head to the motor **HAND TIGHT ONLY**.

IF A GAP EXISTS between the front end of the motor and the head when assembled hand tight, **THE ROCKET SHOULD NOT BE USED**.

By means of an interchange of heads and motors, determine which item is defective and treat as unserviceable, and dispose of as covered in "Handling of Defective Parts."

CAUTION: Excessive force applied when tightening head to motor may cause the lockwire to be pulled out of position. If this occurs, treat the motor as unserviceable and dispose of as in "Handling Defective Parts," page 11.

WARNING

The fin protector is a shorting clip. Let it remain on the rocket until just before loading into the launcher.

When rocket motors are issued in combination launcher-shipment containers, no head shipping support is included because heads are issued in separate containers. Normally heads may be assembled to motors without removing motors from launchers. A quick spin of the head for the last partial turn helps to insure proper seating. If the rocket motor turns in the launcher while screwing on the head, remove the motor sufficiently to obtain a hand hold. **DO NOT** attempt to prevent rocket rotation by holding the fins.

If a launcher containing assembled rounds is not installed immediately on an aircraft, stow it in a suitable temporary facility, muzzle pointing outboard, **REMOTE** from radio and radar apparatus, electric panels, and live wires.

Ready-Service Storage

Tactical situations may make it necessary to store assembled and fuzed rounds in exposed positions above deck or near take-off areas. Such storage should be limited, because prolonged exposure to weather may cause deterioration and/or corrosion to launchers and rockets. Storage of

assembled rockets under these limited conditions in four-round Container Mk 1 Mod 0 is authorized also.

WARNING

Do not fire rocket motors when the propellant temperature is outside safe temperature limits specified on the motor tube.

Firing motors at temperatures outside safe limits may cause erratic performance or motor blowup. If the motor has been exposed to temperatures outside these limits, maintain the motor within safe temperature limits for 6 hours before firing.

Loading the Launcher

In general, launchers for the FFAR consist of multiple nested tubes, arranged in various configurations, which will ripple-fire the rockets.

Detailed descriptive information and instructions for the preparation and loading of launchers is furnished with the launchers. Only general instructions for loading are given here. They must be modified according to construction details of the specific launcher being loaded.

WARNING

Avoid standing directly behind or in front of rounds being loaded into or already in launchers.

Launchers being loaded should be pointed so that personnel and installations are not in the line of possible fire.

Instructions. Examine launcher to insure the absence of all foreign matter. To make good electrical contact, clean launcher contacts of grease and other foreign materials.

Remove fin protector from the assembled round; make sure fin retainer and contact button are in place.

When removing fin protector and handling assembled round, avoid striking the fuzed rocket. Although striking the rocket may not be especially dangerous, it may cause damage that will render the round a dud.

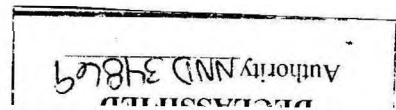

HANDLING AND STORAGE

WARNING

Replace the fuzed head or the round if either have been dropped or struck and damaged. Do NOT remove fuze from damaged or dropped heads. Dispose of damaged heads or rounds as in "Handling Defective Parts," this page.

Carefully insert assembled round into launching tube until the launcher latch seats firmly in the launcher-latch retaining groove.

Take special care when placing rockets in muzzle-loading launchers to assure that round does not fall or slam against the rear of the launcher, because this may damage contact button or launcher contact and prevent the rocket from firing.

Removing Rocket From Launcher

WARNING

Before removing an unfired rocket from a launcher, be sure the safety plug is removed from the firing panel and the remainder of loading check-off list is completed.

Release launcher latch from the retaining groove of the rocket in accordance with instructions accompanying the launcher. Slide rocket from the launcher. As soon as possible after unloading the rocket, CAREFULLY REPLACE FIN PROTECTOR. Place the rocket in ready storage or disassemble and store it.

Disassembly and Storage

Unscrew head from the motor, and replace head shipping support. DO NOT REMOVE FUZE FROM HEAD.

Lightly grease threads of the head to prevent corrosion.

WARNINGS

Store fuzed heads in a high-explosive magazine and handle as high explosives at all times.

Store motors without heads attached, under the same conditions that smokeless powder is stored.

Store motors with heads attached in accordance with regulations governing fixed-case ammunition storage.

DO NOT store motors in the same compartment with or near radio or radar apparatus.

DO NOT store motors adjacent to electric panels or live wires.

Equip all stored motors with fin protectors, except motors stored in combination launcher-shipping containers.

If practicable, maintain below 90° F motor magazine temperature. However, for less than 6 months, storage at temperatures up to 100° F is permissible.

Handling Defective Parts

CAUTION: Do not drop or otherwise rough-handle the rocket motor. Try not to bang the fins, even when they are in a protector. Erratic flights may result from rockets having fins even slightly bent.

Motors dropped less than 2 feet should be examined for external damage. If no damage is evident, they may be considered safe for use.

MOTORS DROPPED MORE THAN 2 FEET SHOULD BE DISPOSED OF, for firing of such motors may cause motor blowup.

DO NOT TAMPER WITH OR ATTEMPT TO REPAIR ANY PARTS OF THE ROCKET. If a motor or fuzed head has been damaged or is defective, remove from service, mark, and return to an ammunition depot.

WARNING

When motors have been exposed to temperatures outside safe temperature limits they must be maintained within safe limits for at least 6 hours before firing.

SAFETY PRECAUTIONS

Assembly

Only personnel essential for the work may be in the vicinity of assembly operations.

NO SMOKING within 200 feet of rocket ammunition.

IF A GAP EXISTS between the front end of the motor and the head when assembled hand tight, THE ROCKET SHOULD NOT BE USED.

Do not remove the fin protector from a round until loading into a launcher, except motors received in combination launcher-shipment containers. The fin protector acts to short the motor.

DO NOT DROP OR OTHERWISE MIS-HANDLE ROUNDS.

Ready-Service Storage

Do not fire rocket motors when the propellant temperature is outside safe temperature limits specified on the motor tube. Firing motors at temperatures outside safe limits may cause erratic performance or motor blowup. If the motor has been exposed to temperatures outside safe limits, maintain the motor within safe temperature limits for 6 hours before firing.

Loading the Launcher

Avoid standing directly behind or in front of rounds being loaded into or already in launchers. Launchers being loaded should be pointed away from personnel and installations.

Be sure the firing circuit is not energized and cannot be energized during the loading process.

Remove fuzes from heads ONLY when it is necessary to change type of fuze.

Removing Rocket From Launcher

Before removing an unfired round from a launcher, be sure the safety plug is removed from

the firing panel and the firing system cannot be energized.

As soon as possible after removing a round from a launcher, carefully replace the fin protector.

Disassembly and Storage

Remove fuzes from heads ONLY when it is necessary to change type of fuze.

Fuzed heads should be stored in a high-explosive magazine and handled as high explosives at all times.

Store motors without heads attached, under the same conditions that smokeless powder is stored.

Store motors with heads attached, in accordance with regulations governing the storage of fixed-case ammunition.

DO NOT store motors in the same compartment with or near radio or radar apparatus.

DO NOT store motors adjacent to electric panels or live wires.

Equip all stored motors with fin protectors, except those in combination launcher-shipment containers.

If practicable, maintain motor magazine temperature below 90° F. However, storage at temperatures up to 100° F for less than 6 months is permissible.

Handling Defective Parts

Dispose of motors dropped more than 2 feet.
Dispose of damaged fuzed heads.

DO NOT TAMPER WITH OR ATTEMPT TO REPAIR ANY PARTS OF A DAMAGED ROUND.

Maintain within safe limits for at least 6 hours before firing, motors which have been exposed to temperatures outside safe temperature limits.

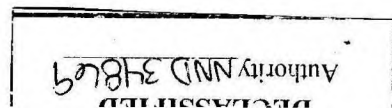

DISTRIBUTION

SNDL Part 1 (No. 66) and Part 2 (No. 24)

Two copies unless otherwise excepted:

21; 22; 23, 23A; 24A, 24B, 24F, 24J; 26F, 26U, 26Z, 26GG; 28A; 29G (5 copies), 29H (5 copies), 29K (5 copies), 29K1 (5 copies), 29L (5 copies); 32C, 32HH, 32JJ; 42A, 42B, 42E, 42I, 42J, 42J1, 42K, 42L, 42M, 42N, 42P, 42S, 42T; 45AA; 46A, 46B, 46C, 46D, 46D1, 46G, 46K, 46R, 46U, 46V, 46Z; F1, F9, F38; G1A (5 copies), G1B, G1D, G1F, G1G, G1H, G2, G3A, G3B, G3C, G3D, G3E, G4A, G5A, G5B, G5C, G5D, G6A, G6B, G7B, G7C, G8G, G8H, G8V, G13, G14, G16, G18, G19, G20; J60, J71; K1, K2A, K2C, K2D, K3, K5D, K5E, K7 (White Oak and Corona only), K8, K10, K12, K20; R20.

Requests for additional copies of OP 1793 should be submitted on NAVEXOS 158, Stock Forms and Publications Requisition, to the District Publications and Printing Office by which addressee is serviced.

11 October 54/3200/1