

RESTRICTED

ORDNANCE PAMPHLET 1187

2"25 SUBCALIBER AIRCRAFT ROCKETS

DESCRIPTION AND INSTRUCTIONS FOR USE



10 FEBRUARY 1945

UNCLASSIFIED

This publication is RESTRICTED and shall be safeguarded in accordance with the security provisions of U.S. Navy Regulations, 1920, Articles 75 $\frac{1}{2}$ and 76.

NAVY DEPARTMENT
BUREAU OF ORDNANCE
WASHINGTON 25, D. C.

10 February 1945

RESTRICTED

ORDNANCE PAMPHLET 1187

2.25-INCH SUBCALIBER AIRCRAFT ROCKETS
DESCRIPTION AND INSTRUCTIONS FOR USE

1. Ordnance Pamphlet 1187 describes, and contains instructions for use of, 2.25-inch subcaliber aircraft rockets.
2. This publication is for reference by all personnel concerned with training and refresher courses employing this ammunition. The tactical use of these rockets is outside the scope of this pamphlet, and may be covered in publications from other sources.
3. This pamphlet does not supersede any existing publication.
4. It is not intended that this pamphlet be carried in aircraft for use therein.
5. This publication is RESTRICTED and shall be safeguarded in accordance with the security provisions of U. S. Navy Regulations, 1920, Articles 75 $\frac{1}{2}$ and 76.



G. F. HUSSEY, JR.
Rear Admiral, U.S. Navy
Chief of the Bureau of Ordnance

CONTENTS

	Page
INTRODUCTION	
What They Are.....	1
Their Purpose	1
Where They Are Used.....	1
Weights and Dimensions.....	1
DESCRIPTION	
General Description	1
The Head	1
The Motor	1
The Firing Indicator.....	2
OPERATION	
How It Works.....	5
Stowage	5
Temporary Stowage	5
Accidental Ignition	5
Assembling the Rockets.....	5
Inspection and Tests.....	6
Personnel of Loading Party.....	6
Testing the Firing Circuit.....	6
Checking the Launchers.....	7
Loading the Launchers.....	8
Aircraft Launchers Mk 4.....	8
Post Launchers	9
Aircraft Launcher Mk 5 Mod 1.....	9
Grumman Launcher	9
Loading the Adapter.....	10
Completing the Electrical Connections.....	10
Preparation for Take-Off.....	10
Pilot's Firing Procedure.....	11
Unfired Rounds	11
Removing Rounds	11
Misfired Rounds	11
SAFETY PRECAUTIONS	12
ILLUSTRATIONS	
Figure 1 2.25-inch Subcaliber Aircraft Rockets.....	iv
Figure 2 Descriptive View of Rocket.....	iv
Figure 3 2.25-inch Rocket Firing Indicator.....	2
Figure 4 Bottom View of Motor with Firing Indicator in Place	2
Figure 5 Method of Packing Rockets in 2.25-inch Rocket Container Mk 1 Mod 0 (Aluminum) and Mk 2 Mod 0 (Steel)	4
Figure 6 Method of Packing Rockets in 2.25-inch Rocket Container Mk 3 Mod 0 (Wood).....	4
Figure 7 Aircraft Launcher Mk 4.....	6
Figure 8 Adapter, Aircraft Launcher Mk 6 Mod 1.....	7
Figure 9 Adapter, Aircraft Launcher Mk 6, Mounted on Aircraft Launcher Mk 5 Mod 1.....	8
Figure 10 Adapter, Aircraft Launcher Mk 6 Mod 1, Mounted on Grumman Aircraft Launcher.....	9

RESTRICTED

iii

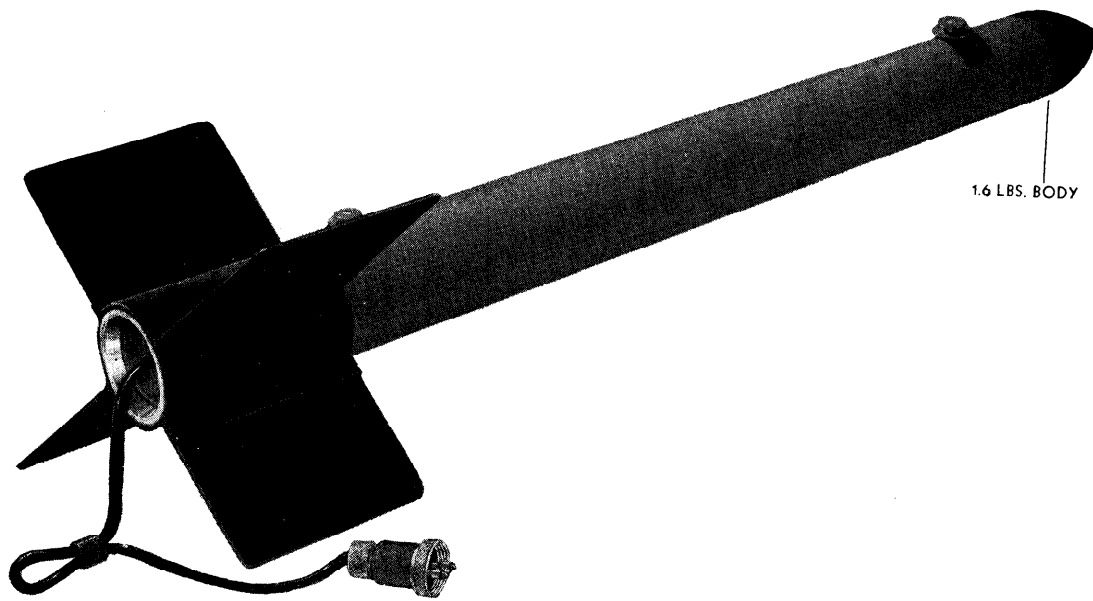

Figure 1.—2.25-inch Subcaliber Aircraft Rockets

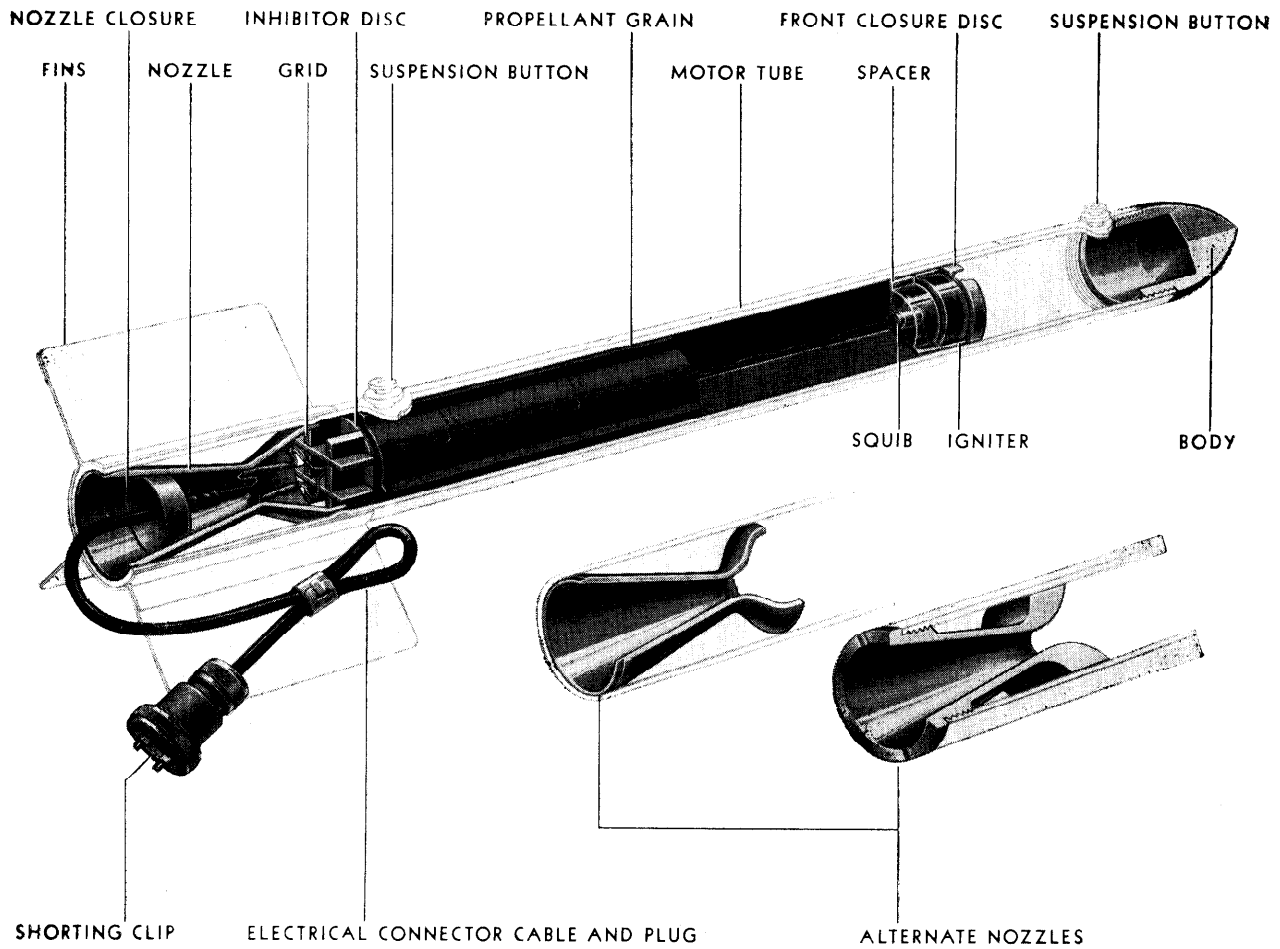

Figure 2—Descriptive View of Rocket

INTRODUCTION

WHAT THEY ARE

The 2.25-inch Subcaliber Aircraft Rockets described in this pamphlet are subcaliber, high velocity, fin stabilized rockets with inert heads.

THEIR PURPOSE

The 2.25-inch Subcaliber Aircraft Rocket is used as a training round in place of the service aircraft rockets.

Only one of the two types of subcaliber rockets is necessary for this purpose since the essential elements in rocket training embody; first, teaching the pilot to put the center of impact of the training round onto the target by adjusting his attack conditions to those originally laid out, and, second, to attempt, by proper fly-

ing, to reduce the overall dispersion to the inherent dispersion of the training round.

The assembly sheet on page 3 lists the various combinations of components now in service.

WHERE THEY ARE USED

These rockets are for use in conducting training and refresher courses in forward firing from aircraft.

WEIGHTS AND DIMENSIONS

The weights and dimensions of the various complete rounds, of their individual components, and of the rounds packed in shipping containers are given in the chart of Physical Characteristics of 2.25-inch Subcaliber Aircraft Rockets on page 3.

DESCRIPTION

GENERAL DESCRIPTION

2.25-inch Aircraft Rockets are composed of two major components, the head and the motor.

The Head is of machined steel, diecast zinc or cast iron. It is threaded at the rear for assembly to the motor and is hollowed out to give the head the correct weight to produce proper ballistic characteristics when the rocket is fired.

The Motor consists of the following parts:

1. **TUBE.** The tube is a seamless, or electrically welded, steel tube which contains the propelling charge and the igniter. It is the combustion chamber for the propellant.

2. **MOTOR SHIPPING CAP.** This cap protects the threads on the front end of the motor and also acts as an additional moisture seal for the front end of the motor. It must be removed before assembly of motor and head.

3. **FRONT CLOSURE DISC.** This disc acts as a seal, keeping out moisture and dirt from the front end of the motor. It also serves to retain the igniter and the grain in place in the motor.

4. **IGNITER.** The igniter is a plastic case con-

taining 14 grams of FFFG black powder and an electric squib. Leads, connected to the squib, pass through the central hole in the propellant grain and extend through the nozzle, where they are connected to the electrical connector cable.

5. **PROPELLANT.** The Propellant is an extruded cylindrical grain of ballistite. Inhibitor discs, cemented to the ends of the grain, control the burning area and, hence, the pressure developed.

6. **GRID.** The grid supports the powder grain. During burning, it prevents the powder grain from sliding rearward and clogging the nozzle opening.

7. **NOZZLE.** The nozzle is a steel venturi through which the gases flow. It directs the gas jet in the desired direction and also provides for the expansion of the gases in the exit cone.

8. **NOZZLE CLOSURE.** The nozzle closure seals the rear end of the motor. It is crimped to the electrical connector cable, providing a moisture proof seal.

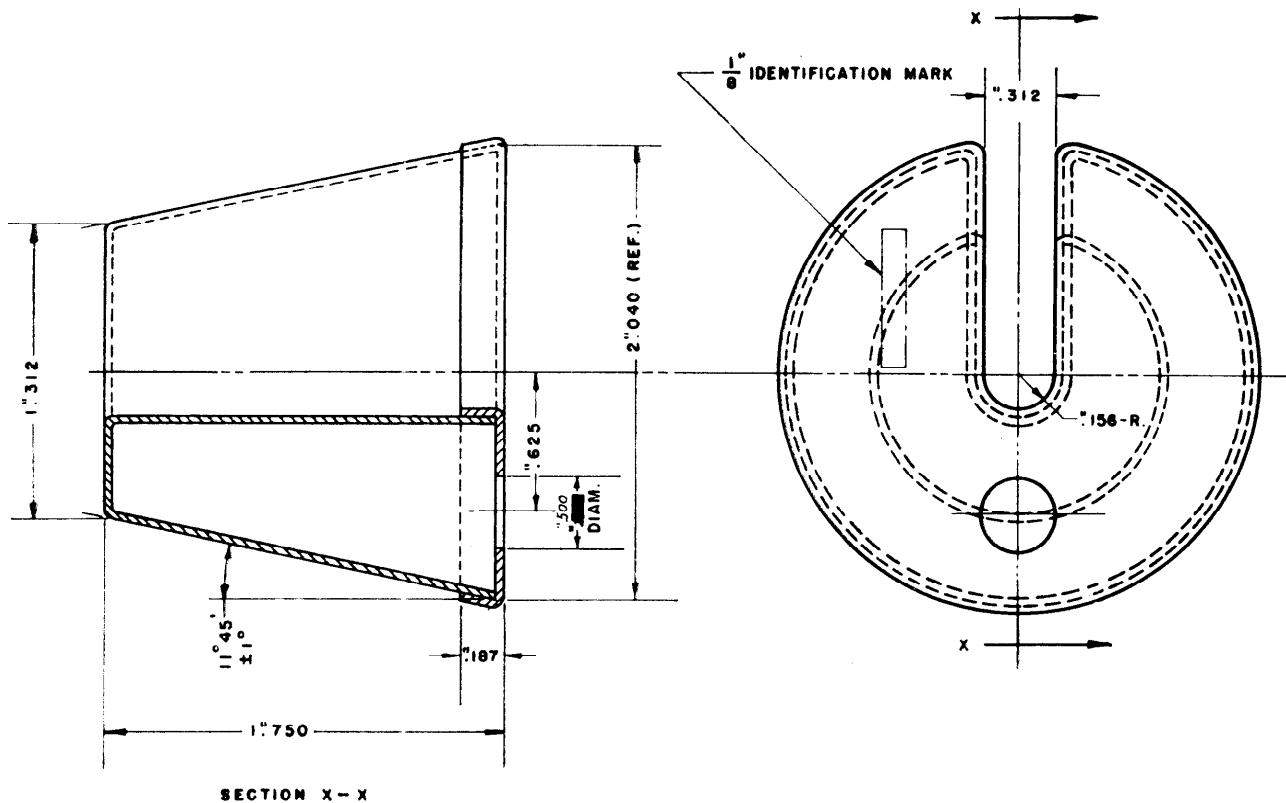

Figure 3—2.25-inch Rocket Firing Indicator

9. ELECTRICAL CABLE AND CONNECTOR PLUG. This component is sometimes referred to as the "pigtail." It terminates in a male plug for insertion into the socket on the launcher or in the plane wing.

10. SUSPENSION BUTTONS. The suspension buttons provide a means for suspending the rocket from the launcher or adapter.

11. FINS. The fin assembly consists of four similar parts welded together to form a metal sleeve, with four rectangular fins projecting radially at equal spacing. The sleeve is welded to the motor.

Firing Indicator. The 2.25-inch Rocket Firing Indicator consists of eight grams of lampblack enclosed in a papier maché container. This indicator is to be attached to the rear of the 2.25-inch Rocket Motor. When the motor is ignited, the blast shatters the papier maché container and disperses the lampblack to form a black puff which serves to indicate the moment of firing of the rocket. The indicator is shown in Figure 3.

To Install: Place the indicator against the nozzle closure with the slot for the electrical connector cable pointing downward. Then place a strip of tape across the rear of the container to further secure it to the motor as in Figure 4.

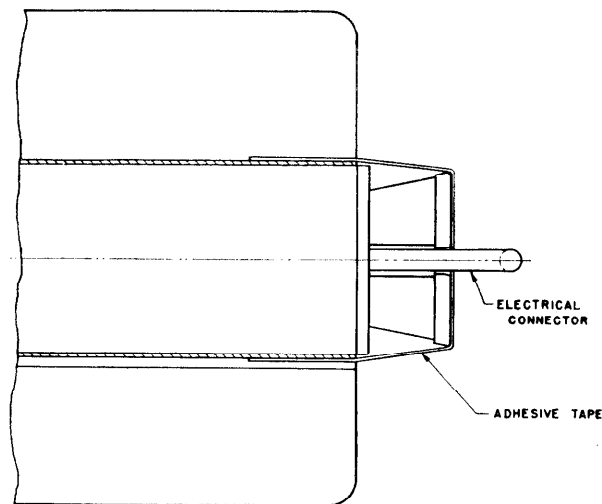

Figure 4—Bottom View of Motor with Firing Indicator in Place

PHYSICAL CHARACTERISTICS OF 2.25 SUBCALIBER AIRCRAFT ROCKETS

MAJOR COMPONENTS OF THE ROCKETS

Motor											
Head				Designation		Propellant		Igniter		Weight Lbs.	
Mark	Mod	Material	Length In.	Weight Lbs.	Mark	Mod	Mark	Mod	Length In.		
1	0	Steel	3.75	1.6	10	0	16	0	12	26.0	10.25
1	1	Zinc	3.75	1.6	10	1	16	1	12	26.0	10.25
2	0	Steel	8.75	8.6	11	all	16	1	12	26.0	10.25
3	0	Steel	3.75	1.6	12	0	17	0	13	26.0	9.6
3	1	Zinc	3.75	1.6	13	all	17	0	13	26.0	9.6
3	2	Zinc	3.75	1.6	11	all	16	1	12	26.0	10.25
3	3	Cast Iron	3.75	1.6	11	all	16	1	12	26.0	10.25

ASSEMBLY SHEET

Complete Round Designation	Weight Lbs.	Length In.	Motor				Head				Subcaliber Designed For:
			Mark		Mod		Mark		Mod		
			Mark	Mod	Mark	Mod	Mark	Mod	Mark	Mod	
2.25 TA001	11.85	29	10	0	1, 3	all	1, 3	all	3.5-inch Aircraft Rocket		
2.25 TA002	11.85	29	10	1	1, 3	all	1, 3	all	3.5-inch Aircraft Rocket		
2.25 TA003	18.85	34	10	0	2	0	2	0	5.0-inch Aircraft Rocket		
2.25 TA004	18.85	34	10	1	2	0	2	0	5.0-inch Aircraft Rocket		
2.25 TA005	11.85	29	11	all	1, 3	all	1, 3	all	3.5-inch Aircraft Rocket		
2.25 TA006	18.85	34	11	all	2	0	2	0	5.0-inch Aircraft Rocket		
2.25 TA007	11.2	29	12	0	1, 3	all	1, 3	all	5.0-inch Aircraft Rocket		
2.25 TA008	11.2	29	13	all	1, 3	all	1, 3	all	5.0-inch Aircraft Rocket		

SHIPPING AND STOWING WEIGHTS AND DIMENSIONS

Designation		No. Rockets Per Box	Box Size				Weight When Packed
			Length (in.)	Width (in.)	Height (in.)	Cu. Feet	
Mark	Mod						
1	0	4	29.03	11.22	11.87	2.24	68
2	0	4	29.03	11.22	11.87	2.24	80
3	0	8	30.1	17	12	3.56	126.8

RESTRICTED

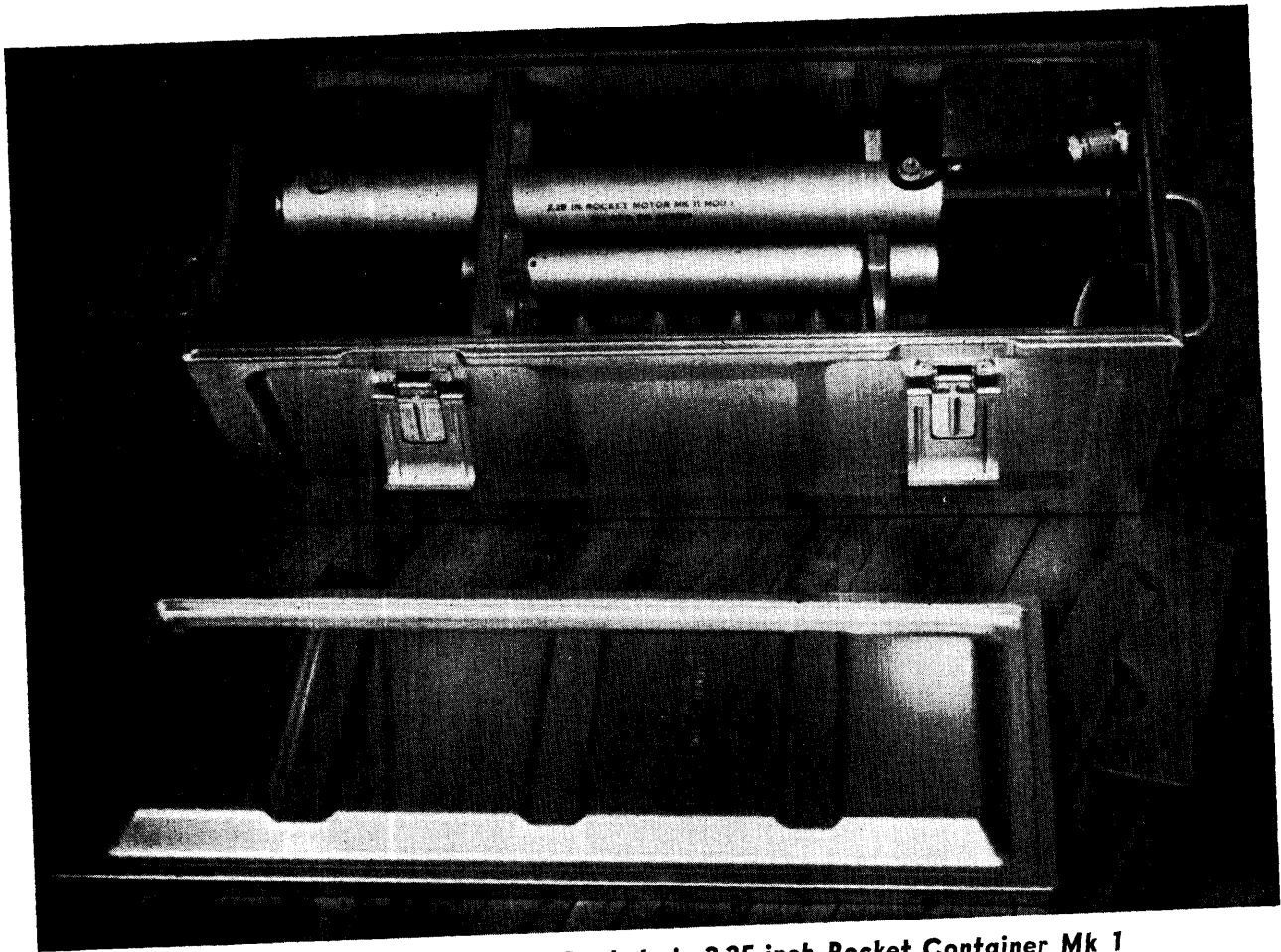

Figure 5—Method of Packing Rockets in 2.25-inch Rocket Container Mk 1 Mod 0 (Aluminum) and Mk 2 Mod 0 (Steel)

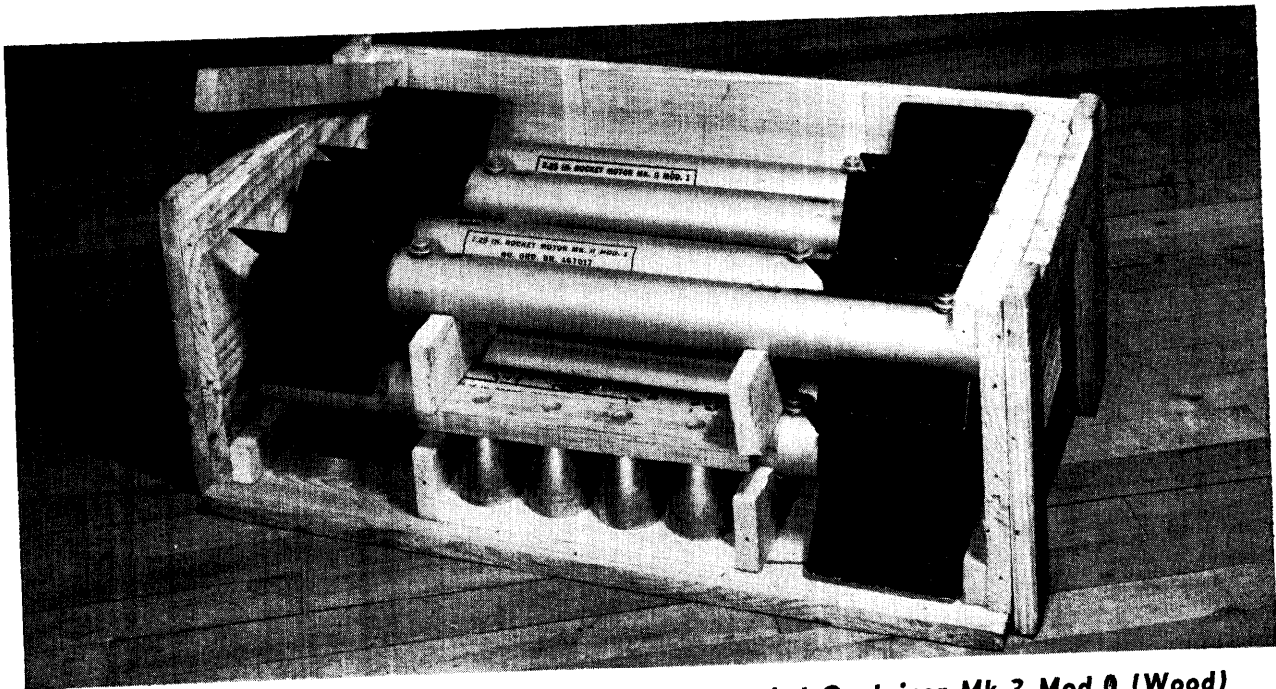

Figure 6—Method of Packing Rockets in 2.25-inch Rocket Container Mk 3 Mod 0 (Wood)

RESTRICTED

OPERATION

HOW IT WORKS

When the firing circuit is closed, an electrical impulse passes through the squib and sets off the black powder in the igniter, filling the interior of the motor tube with hot burning gases under high pressure. These gases from the black powder raise the surface of the propellant to the ignition temperature. As soon as the propellant begins to burn, it generates a large quantity of gas and causes the pressure inside the tube to be maintained. A force is thus exerted in all directions on the interior surface of the tube and, since there is an opening at one end of the tube, the gas rushes out through it without exerting any force on the area of the opening. It does, however, exert its full force on the corresponding area of the closed end forward, and on the exit skirt of the nozzle. Thus, a force or thrust is created, which drives the rocket forward.

STOWAGE

The rockets are to be stowed in smokeless powder magazines in the shipping containers. Unfired rounds removed from the launchers are to be put back in the shipping containers, with motors and bodies unassembled as shipped, and stowed in the magazine.

Although the motor contains both black powder and ballistite, for purposes of stowage the entire motor is classified as "smokeless powder." The plastic igniter case contains about 14 grams of black powder and is of quite durable construction. The igniter is sealed into the motor by the front closure disc and, thus, does not constitute a serious fire hazard.

TEMPORARY STOWAGE

Rockets should be kept in the shade and away from direct sunlight. Rockets should never be fired when the motor has been exposed, for more than one hour, to temperatures outside the safe firing temperature limits specified on the motor tube.

ACCIDENTAL IGNITION

Until the head is secured to it, the motor is non-propulsive. The motor is shipped and stored with the metal shipping cap on the front end. This cap is of light construction and will blow out at relatively low pressures. The hot gas blast will issue from both ends of the motor and, hence, constitute a fire hazard. If the motors are stowed in contact with one another, it is not probable that one motor will ignite those around it.

The ballistite propellant grain can be accidentally ignited as follows:

1. By feeding electric current to the igniter. About one volt at $\frac{1}{2}$ amp is required to set it off.
2. By exposing the motor to fire or temperatures above 350° F.
3. By subjecting the motor tube to small arms fire, or high velocity bomb or shell fragments.

Caution: Every precaution shall be taken to guard against exposing the motor to any of the conditions described above.

ASSEMBLING THE ROCKETS

Prior to assembly, both ends of the motor shall be examined to see that neither the front closure disc nor the nozzle closure has been broken. If one of these seals has been broken, the motor should be tagged to show the nature of the trouble and any other information which may aid in determining the cause of the break. If practicable, the motor should then be turned in to the nearest ammunition depot. If this is not practicable, the motor may be disposed of by lowering it into deep water, or turned over to a bomb disposal officer for disposition.

The mating threads of all 2.25-inch Aircraft Rocket heads and motors are to be carefully luted with any suitable luting compound, such as Crater compound, or red or white lead, of such consistency that it can be applied with a brush.

To assemble the rocket: The head should be seated on the motor tube as tightly as possible

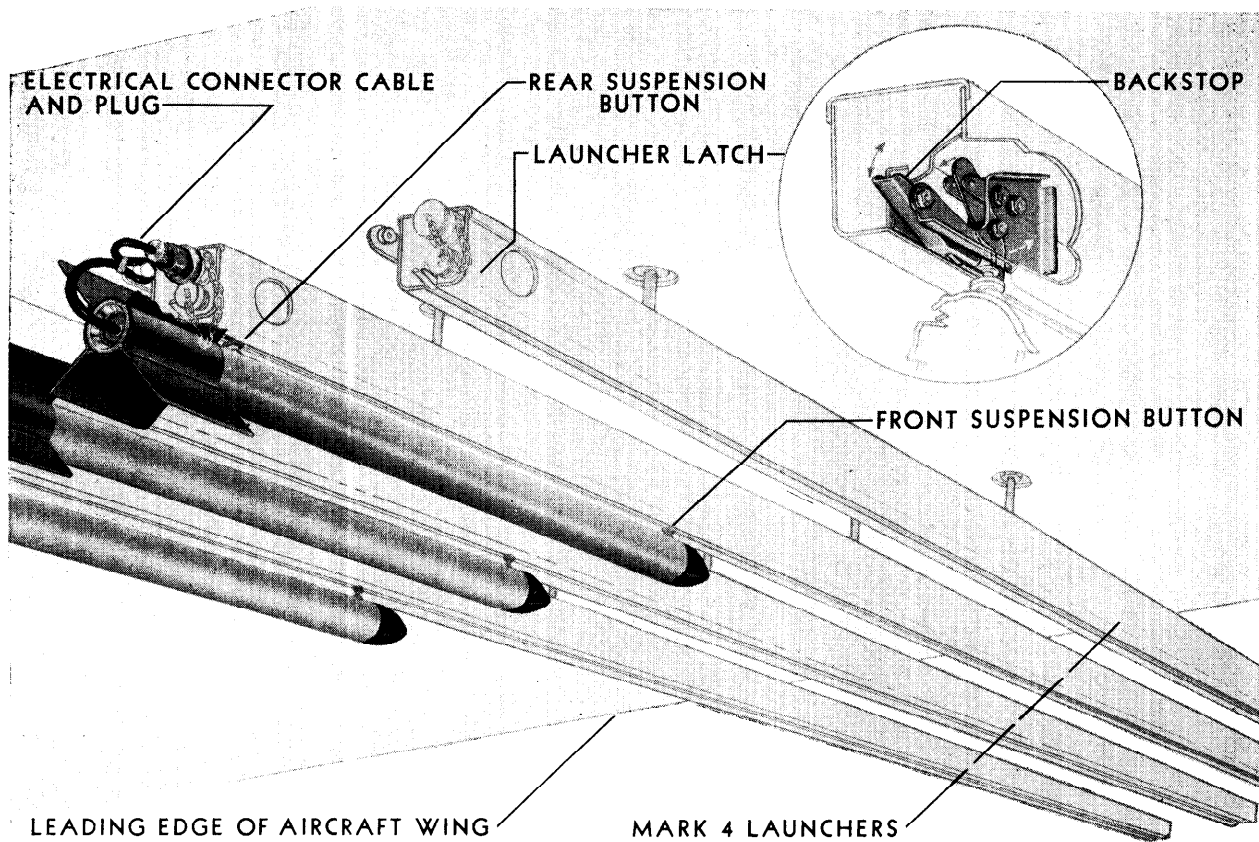

Figure 7—Aircraft Launcher Mk 4

using a Stillson type wrench on the head and a strap wrench **only** on the motor to insure a tight fit.

INSPECTION AND TESTS

Personnel of Loading Party—A “Safety Officer” must be in charge of every loading and unloading operation and will have a loading crew of trained and responsible men under his command. It is his duty to see that all safety rules and precautions pertaining to the loading operation are enforced.

When a number of airplanes are being loaded at the same time the “Safety Officer” may be unable to supervise personally all steps in each loading operation. In this case he will delegate a member of each loading crew to see that all safety rules and precautions are observed by his crew.

Testing the Firing Circuit—

1. Circuit Testing Devices—The circuit test-

ing devices now in service include the Circuit Test Kit Model I, Circuit Test Kit Model II, the Circuit Test Plug Model I and various “home-made” devices.

a. The Test Kit Model I was designed to test the function and continuity of the rocket circuit; a limited quantity was made, and it has been supplanted by the Test Plug Model I. The latter is a compact plastic plug with a 26 volt light bulb and an electrical plug to match the rocket launcher socket.

b. The Test Kit Model II was designed to test for stray, low voltage in the launcher circuit and to provide an auxiliary means for testing the bulbs in the test plugs. It consists of a case containing a low voltage light bulb, 5 pencil type flash light cells, a resistance, a receptacle, a switch, and a short electrical lead with a plug to fit the launcher sockets. As a safety measure, the socket on the case was designed to allow the electrical plug of the test kit to make contact with the battery through the resistance.

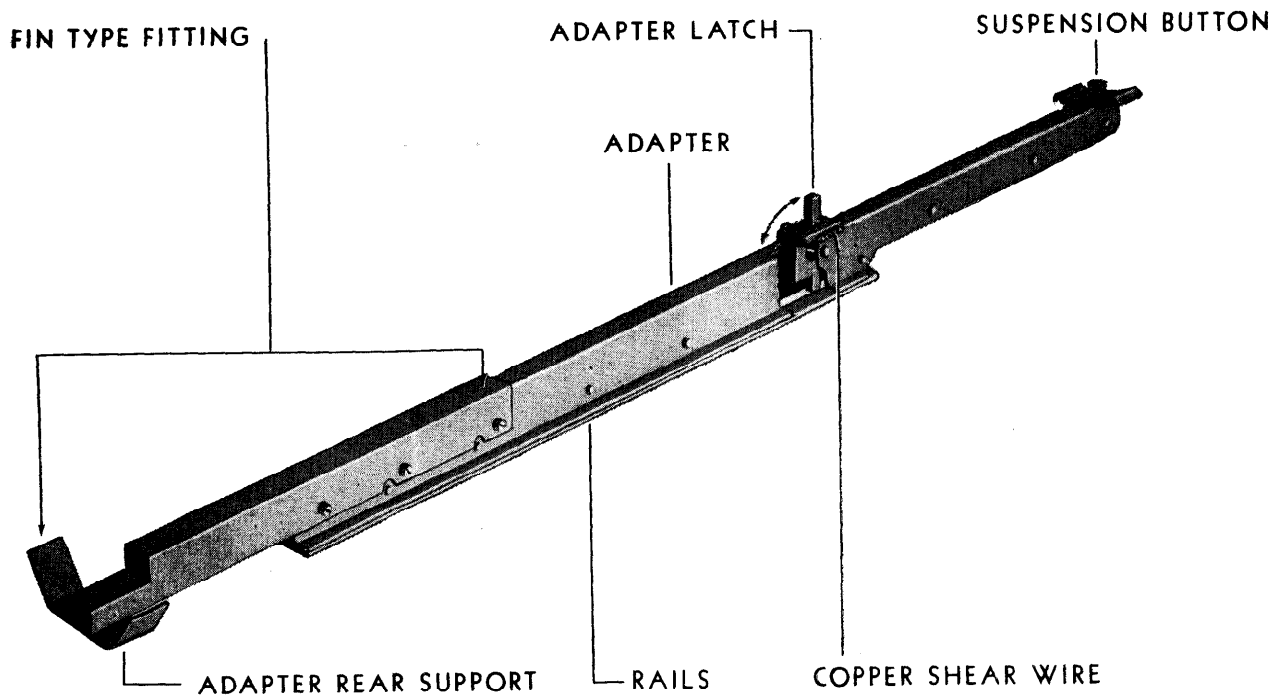

Figure 8—Adapter, Aircraft Launcher Mk 6 Mod 1

but to prevent the shorter pins of a rocket pig-tail plug from reaching the battery circuit, in case a rocket is inadvertently plugged into the test kit. The extra long pins of the test plug will reach a switch within the test kit, thereby shorting out the resistance and allowing the full $71\frac{1}{2}$ volts of the battery to light the test plug.

2. **Circuit Testing Procedure**—The procedure for testing rocket circuits specified in the past can be appreciably simplified, resulting in a saving of time and an increase in safety. The practice of testing circuits for continuity immediately before loading and on the flight line should be discontinued. Continuity tests need be performed on rocket circuits only as often as performed on other armament circuits during normal operation, or after unloading rockets when misfires have occurred. **Continuity tests should never be made with rockets loaded on the launchers.**

To Perform a Continuity Test Proceed as Follows:

1. Inspect and verify that there are no rockets loaded on launchers.
2. Insert one test plug into each rocket launcher socket.

3. Close all necessary switches.

4. Actuate the rocket firing switch.

5. Verify that the test plugs light in the proper sequence by checking the test lights with each setting of the station controller or rocket selector switch.

Checking the Launchers—

1. When cameras are to be used, the cameraman shall load the cameras and wind the films into position for the first picture before ammunition is brought up to the airplane.

2. Before the rockets are loaded, the safety officer shall obtain the safety plug and then inspect the launchers to ensure that:

- a. All fittings are secure.
- b. Launcher and launcher parts are not damaged.
- c. No obstructions foul the launcher slot.
- d. All moving parts are in working order.
- e. In the case of the Aircraft Launcher Mk 4, the trigger arm is open so that it does not foul the forward suspension button.

Note: If the safety officer believes that any of the launchers are unsafe for use, he is authorized and required to stop the use of those launchers.

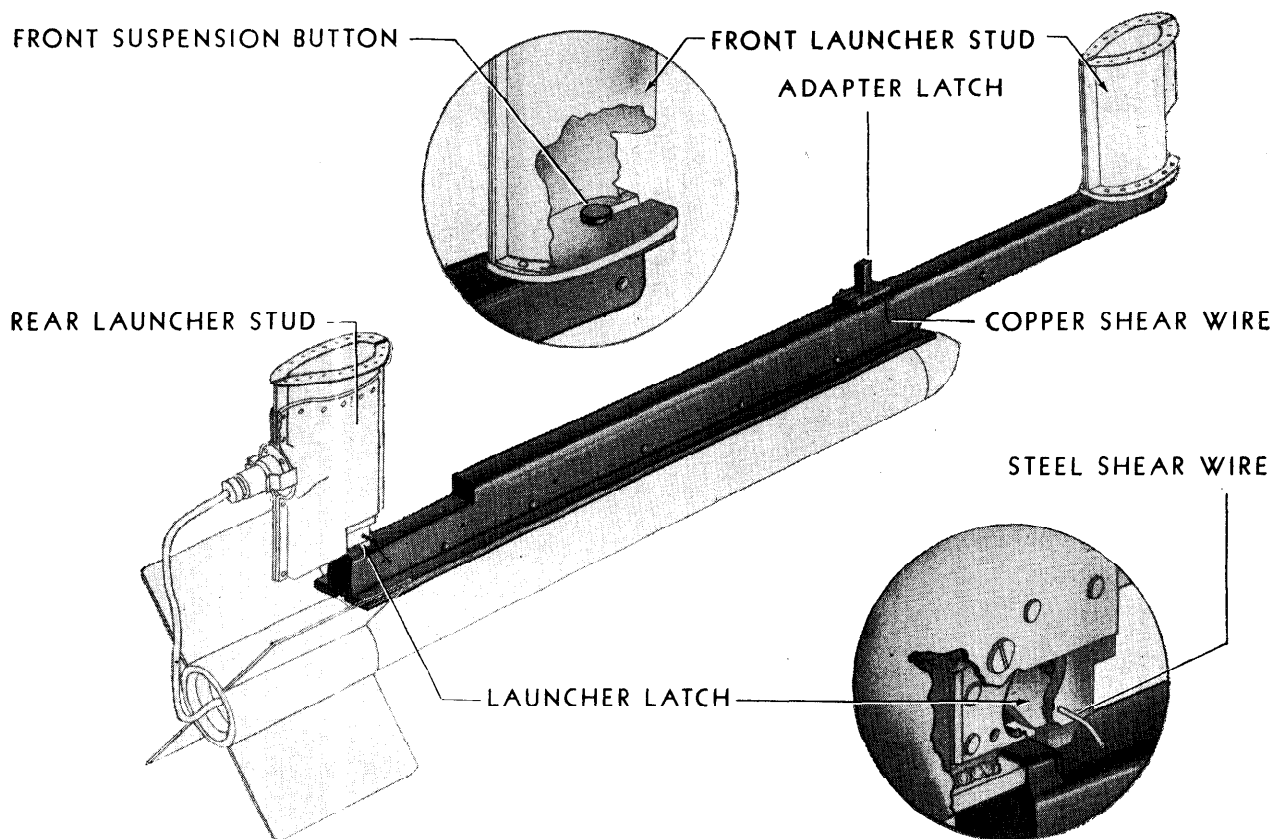

Figure 9—Adapter, Aircraft Launcher Mk 6, Mounted on Aircraft Launcher Mk 5 Mod 1

3. The safety officer shall notify the pilot, if he is in the airplane, that loading operations are to begin.

4. The safety officer shall check the electrical installation as follows:

a. See that the main battery switch, the master armament switch, and the rocket armament power switch are in the OFF position.

b. See that the safety plug is kept in plain sight of the loading crew during the loading operation.

5. After seeing that the aircraft is pointed away from other aircraft, buildings, vehicles, personnel, magazines and other structures, and that unauthorized persons are away from the airplane, the safety officer, with the safety plug in plain sight, shall authorize the loading to begin.

LOADING THE LAUNCHERS

Aircraft Launcher Mk 4—Figure 7. The load-

ing crews shall load the launcher from the rear end as follows:

1. Raise the completely assembled round, holding it parallel to the launcher, and engage the front suspension button in the "T-Slot" in the rear end of the launcher and slide the round forward. The back stop will spring out of the way.

2. Engage the rear suspension button and slide the round forward until the backstop drops into place.

3. Slide the round to the rear until it seats firmly against the backstop.

4. Close the trigger arm and secure in place with a 18 ga. (.040 inch diameter) soft copper shear wire.

5. Ensure that the round is properly held in place by trying to push it forward or rearward.

6. Hook the "pigtail" loop into the catch at the rear of the launcher and secure. **Do not remove the shorting clip, or plug in the electrical connector at this time; let it hang loose.**

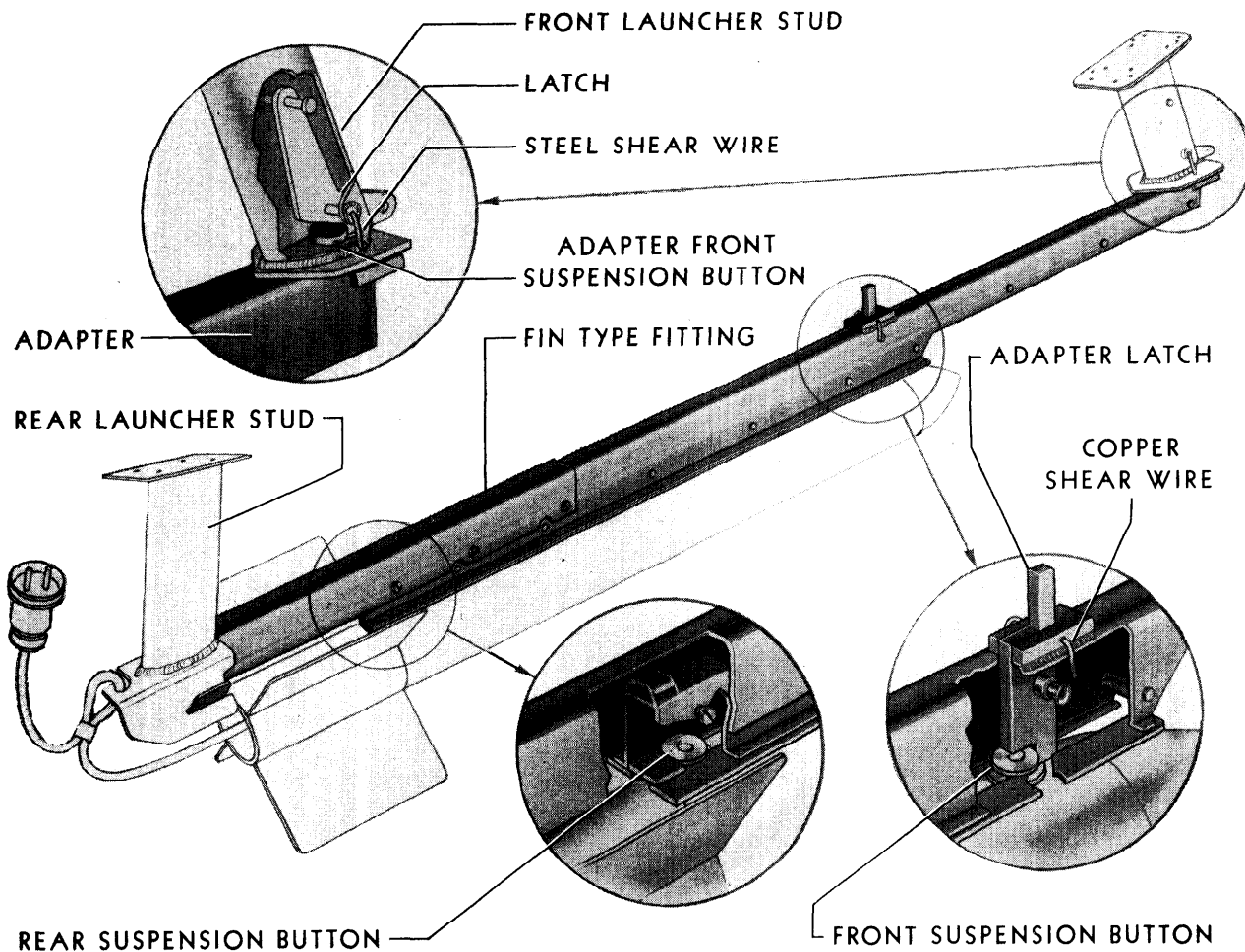

Figure 10—Adapter, Aircraft Launcher Mk 6 Mod 1, Mounted on Grumman Aircraft Launcher

Post Launchers—When it is desired to fire subcaliber ammunition from post type launchers, an adapter, Figure 8, is necessary, because the suspension button spacing on the subcaliber rockets is different from that of the standard Aircraft Rockets. The adapter has rails and a latch, which will accommodate the subcaliber rockets, and has fittings so it can be suspended from different varieties of post launchers.

Aircraft Launcher Mk 5, Mod 1—Figure 9. This launcher supports an adapter, (Aircraft Launcher Mk 6) in the same manner as a rocket and can be handled by one man as follows:

1. Raise the adapter, bringing the fore and aft suspensions in line with, and slightly forward of, the launcher studs.
2. Engage the suspension button in the forward launcher stud.

3. Raise the latch in the rear launcher stud, engage the adapter rear support and then slide the adapter rearward.

4. Close the latch and insert the largest and strongest wire commensurate with the size of the latch opening.

5. Ensure that the adapter is firmly held by trying to push it forward and rearward.

GRUMMAN LAUNCHER—FIGURE 10. This holds the standard round by the front suspension lug and at the rear by the fins. For this launcher, a fin type fitting bolts to the adapter and provides the rear support. The adapter with the fin type fitting bolted to it is the Aircraft Launcher Mk 6 Mod 1. The adapter is mounted to the Grumman launcher using the following steps:

1. Raise the adapter, holding it parallel to

the fore and aft line of the launcher with the fin type fitting to the rear.

2. Engage the rear of the fin type fitting on the adapter in the slots in the rear launcher stud.

3. Raise the latch in the front launcher stud, engage the adapter front suspension button, and then slide the adapter rearward.

4. Close the latch and insert the largest and strongest wire commensurate with the size of the latch opening.

5. Ensure that the adapter is firmly held by trying to push it forward and rearward.

Loading the Adapter—The rockets are loaded in the adapter from the front end as follows:

1. Raise the completely assembled round, holding it parallel to the launcher, and engage the rear suspension button in the T-slot in the front end of the launcher. Push the lever arm of the latch, which protrudes above the top of the launcher, to the rear, thus raising the latch out of the way, and slide the round rearward.

2. Engage the forward suspension button in the T-slot, keeping the latch out of the way in the same manner as above, and slide the round rearward until it is stopped by the backstop.

3. Close the latch and wire in place with an 18 gauge .040 inch soft drawn **copper** shear wire, which will be found in each shipping container. **Caution:** Do not use steel wire in the adapter latch.

4. Insure that the round is in place by trying to push it forward and rearward.

5. Hook the pigtail loop in the catch at the rear of the launcher and secure. **Do not remove the shorting clip, or plug in the electrical connector at this time; let it hang loose.**

Completing the Electrical Connections—Immediately before plugging the electrical connectors into the launcher sockets, and after all unauthorized personnel are clear of the plane, the following safety tests must be conducted on the firing circuits:

1. Verify that the master armament switch is off and that the safety plug is removed; (safety plugs are used with rocket station controllers but not with rocket selector switches).

2. Plug the Launcher Test Kit Model II into each launcher socket in turn and observe that the bulb does not glow.

3. Insert the test kit plug into the test kit

receptacle to check the functioning of the test kit bulb. **If the bulb fails to glow when plugged into the launchers, but lights when plugged into the battery circuit of the test kit, the launchers are free of dangerous stray voltage; the rocket pigtails may then be plugged into the launchers.**

4. If the bulb glows when plugged into launchers or fails to glow when plugged into the battery circuit of the test kit, **do not plug in pigtails.** In the former case, follow procedure (f) below; in the latter case, follow procedures (a) through (f) below:

a. Replace the bulb in the test kit circuit with the spare that is provided with each kit.

b. Test the functioning of the new bulb by inserting the test kit plug into the test kit receptacle.

c. If the bulb fails to glow, the test kit is defective, and the entire safety test should be repeated with a new test kit.

d. If the bulb glows when tested, the entire test procedure should be repeated, carefully watching the bulb.

e. If the bulb is observed to glow or to burn out when plugged into the launchers, or if the bulb again fails to glow when the kit is checked at the end of the test procedure, the plane is unsafe to carry rockets.

f. Unload rockets and restrict the plane from carrying rockets until such time as the launcher circuits can be checked and the stray current eliminated.

NOTE: Any tester employing a light bulb rated at 2 volts or less can be satisfactorily used. The recommended bulb is Mazda 351.

1. After the null voltage tests are complete, the ordnance men, one to each wing, shall plug in the electrical connection plug of each round consecutively, from inboard out. **He must stand to one side of the round** being connected and to one side of rounds already connected. Shorting clips, which are to be removed before plugging in, should be saved for future use in case the round is not fired.

2. When all rounds are plugged in, the ordnance man shall notify the safety officer and then leave the loading area.

PREPARATION FOR THE TAKE-OFF

The safety officer shall now:

1. Notify the pilot that the loading is completed.
 2. Note that the master armament switch and rocket armament switch are still **OFF**.
 3. If a camera is being used, see that the torpedo camera switch is set at the **ON** position.
 4. See that the launcher selector switch is set on "1."
 5. Check to see that the safety plug is in the possession of the pilot.
- The rockets are now properly loaded and the plane is ready to take off.

PILOT'S FIRING PROCEDURE

When the plane is over the target area, the following procedure is used in firing the rockets:

1. See that the launcher selector switch is set to "1."
2. Place the safety plug in its receptacle in the station distributor.
3. Turn on the master armament switch.
4. Turn on the rocket armament power switch. The panel light should now glow.
5. Set the camera switch as desired.
6. Press the firing button on throttle, or on control wheel.

After firing has been concluded, or when preparing to land, all the station distributor power switches are to be turned **OFF**, and the safety plug is to be removed from the circuit.

UNFIRED ROUNDS

When a plane returns with an unfired round on a launcher, observe the safety precautions used in loading the launchers and proceed as follows:

1. See that the safety plug is removed from the circuit and is kept in plain sight.
2. Notify the pilot that rounds are to be removed.
3. See that the airplane is properly oriented with respect to structures, etc.
4. See that the master armament and rocket armament switches are off.
5. See that no one stands in front of, or to the rear of, the launchers.
6. Keep unauthorized personnel away.

Removing Rounds—The safety officer shall have an ordnance man remove the electrical connector plugs from outboard in, and replace

the shorting clips. The loading crew shall then remove the rounds from the launcher as follows:

1. Unhook the connector cable (pigtail) loop.
2. Remove the shear wire.
3. Open the trigger arm.
4. On the Aircraft Launcher Mk 4, lift the backstop and slide the round out to the rear.
5. On the adapter, slide the round out to the front.
6. Remove body from motor, and stow components.

MISFIRED ROUNDS

In case a plane returns with a misfire, the following procedure is to be followed:

1. See that the safety plug is out of the station controller and hanging in plain sight and that the master armament and rocket armament power switches are **OFF**.

Caution: A ten minute interval is to elapse between the last attempt at firing the round and any attempt to remove the round from the launcher.

2. The plane is to be pointed in a safe direction away from groups of personnel and structures.

3. If the nozzle closure is in place, the round may be unloaded in the same manner as an unfired round. The rocket is then labeled as a misfire and, if desirable in the opinion of the safety officer, it may be used again. If the rocket is a misfire for a second time, after removal from the launcher, the head is to be removed and the motor tagged to show the nature of the trouble or any other information which may aid in determining the cause of the misfire.

4. If the nozzle closure has been blown out, a hangfire may exist. If practicable, the head should be removed while the rocket is on the launcher. Extra precautions should be taken in handling these rounds. The motor shall be unloaded from the launcher and tagged to show the nature of the trouble and any other information which may aid in determining the cause of the misfire. The motor should then be delivered to the nearest ammunition depot. If this is not practicable, the motor may be disposed of by lowering into deep water or in a manner designated by the officer in charge.

SAFETY PRECAUTIONS

The dangerous nature of rockets requires the observance by all personnel of certain rules designed to safeguard personnel and property. Strict adherence to these rules may mean the difference between life and death or serious injury to personnel and observers. It is the duty of the safety officer to enforce safety regulations and to prevent unsafe conditions.

1. The safety plug must be removed from the firing circuit and kept in plain sight at all times while loading and unloading rockets.

2. No smoking or fires are to be allowed in the vicinity where this ammunition is being stored or handled.

3. All launchers shall be tested at least once each day of firing, and before any rockets are loaded, to ensure that the electrical system is in good working order.

4. If practicable during loading operations, only the loading crew, the safety officer, and the pilot and plane crew (if they are in the plane) are allowed within 50 feet of the plane; and any observers shall remain out of line, in front and rear of the launcher.

5. When loading operations are to begin, the safety officer shall notify the pilot. At this time, the pilot or the safety officer must see that the following switches are off:

- a. The main battery switch.
- b. The master armament switch.
- c. The rocket power armament switch.

The safety officer shall check personally or with the pilot to see that the safety plug is out and in plain sight during the entire loading operation.

6. Firing circuits are not to be tested under any circumstances while any ammunition is plugged in on the launchers.

7. If practicable, while rounds are being loaded, the aircraft must be pointed away from other aircraft, buildings, vehicles, personnel, magazines, and other structures, and must not be pointed in any direction considered unsafe by the safety officer.

8. After rounds are loaded, and before connector plugs are plugged in, the safety officer

may permit official observers to approach the plane for inspection, but they shall not stand in line with the launchers either at the front or at the rear. During this time, no one shall handle any part of the launchers or the ammunition.

9. Before plugging in the electrical connector, each launcher shall be tested with a null-voltage test light to make sure the circuit is dead. After each test of each launcher the null-voltage test light shall be tested to insure that it is not burned out.

10. The ammunition trailer and the loading crew must not be in the loading area during the time that the rounds are being plugged in.

11. The safety officer shall authorize one man to plug in the connector plugs. While this is being done, this man must stand to one side of the launcher being plugged in, and, in addition, he must keep to one side of all launchers that he has already plugged in. He must plug in the connectors, working consecutively, inboard out, first one wing then the other.

12. When loading is completed, the safety officer shall check to see that the master armament switch and the rocket power switch are left off, and the rocket selector switch is turned to "1." He then turns the safety plug over to the pilot.

13. The master armament switch and the rocket power switch must be left in "Switch-Off" position except when the plane is over the target area.

14. The safety officer must see that the loading area is safe before allowing planes to enter.

15. Rocket motors must be kept in the shade to avoid overheating from direct rays of the sun.

16. Rocket motors must never be fired when propellant temperature is outside of temperature limits indicated on the motor.

17. The shorting clip on the electrical connector shall never be removed until the electrical connector is to be plugged in.

18. The electrical connector shall not be plugged into the socket in the plane wing until so authorized by the safety officer.

[Faint, illegible text block]

Standard Navy Distribution List No. 34
[Faint, illegible text block]

[Faint, illegible text block]