

No. 2017

**SERVICE HANDBOOK**  
**OF THE**  
**155-MM HOWITZER MATÉRIEL**  
**MODEL OF 1918 (Schneider)**  
**MOTORIZED**  
**WITH INSTRUCTIONS FOR ITS CARE**

DECEMBER 14, 1918



WASHINGTON  
GOVERNMENT PRINTING OFFICE  
1920

	Page
Tools and accessories .....	58-61
Air pump.	
Liquid pump.	
Reservoir for compressed gas.	
Pressure-gage adapter.	
The filling pipes.	
Pressure gage.	
Loading barrel.	
Wheel mats.	
Drag rope.	
Funnel measure and funnel pipes.	
Sponge, staff, and slush brush.	
Rammer.	
Sighting staff.	
Retracting rope and tackle block.	
Sights .....	63-77
The quadrant sight, Model 1918 (Schneider).	
Nomenclature of parts.	
Panoramic sight, Model 1917.	
Nomenclature of parts.	
Use of the panoramic sight.	
For direct fire.	
For indirect fire.	
The peep sight.	
Use of the peep sight.	
Sight extension.	
Gunners quadrant, Model 1918.	
Use of the gunners quadrant.	
Night lighting equipment.	
The 155-mm. howitzer carriage limber .....	73-77
Table of weights and principal dimensions.	
Nomenclature of parts.	
Description of the limber.	
The pole socket and pole.	
Wheels.	
The 155-mm. howitzer caisson .....	78-90
Table of weights and principal dimensions.	
Nomenclature of parts.	
Description of the caisson.	
The chest.	
Spring supporting mechanism.	
The road brake.	
The wheels.	
The reel.	
Antiaircraft machine-gun matériel .....	90-93
Table of weights and dimensions.	
General description.	
Antiaircraft machine-gun mount, Cygnet type.	
Antiaircraft machine-gun tripod, Model 1918.	
Browning machine-gun tripod, Model 1917.	
Staff observation car .....	93-96
Table of weights and outline specifications.	
Brief description of body.	
Brief description of the chassis.	

	Page.
Reconnaissance car.....	96-97
Table of weights, principal dimensions, etc.	
Brief description.	
Artillery tractor, 2½-ton.....	97-99
Table of weights and dimensions.	
Brief description.	
Artillery tractor, 5-ton.....	99-101
Table of weights and dimensions.	
Brief description.	
Outline specifications.	
Ammunition truck.....	101-104
Table of weights, dimensions, and outline specifications of body.	
Brief description of ammunition truck body.	
Weights and outline specifications of all 2-ton chassis, Nash models.	
Brief description of chassis.	
Antiaircraft machine-gun trailer.....	104-105
Principal dimensions and outline specifications.	
General description.	
Artillery repair truck.....	105-107
Weights and specifications.	
General description.	
Chassis.	
Body.	
Artillery supply truck.....	107-109
General weights and dimensions.	
Brief description.	
Chassis.	
Body.	
Load.	
Light repair truck, Model 1918.....	109-111
Weights, dimensions, etc.	
Brief description of chassis.	
Brief description of light repair truck.	
The reel, Model 1909 MI.....	111-119
Weights and principal dimensions.	
Nomenclature of parts.	
Description.	
The cart, Model 1918.....	119-125
Weights and principal dimensions.	
Nomenclature of parts.	
Description.	
Oils, lubricants, and cleaning matériel.....	125-128
Engine oil, No. 1.	
No. 4½ lubricant.	
Flake graphite.	
Dixon's carriage grease.	
Clock oil.	
Hydroline.	
Glycerin and water.	
Slushing oils.	
Kerosene.	
Miscellaneous cleaning matériel.	

PART II.—INSTRUCTIONS FOR THE CARE, MAINTENANCE, AND OPERATION OF THE  
MATÉRIEL.

	Page
Maneuvering the carriage.....	12
Howitzer in traveling position.	
Howitzer in battery position.	
Care and maintenance of the matériel.....	129-13
Oils and greases.	
Care of the howitzer.	
Care of the carriage and other vehicles.	
To grease limber and caisson wheels.	
Care of the recoil and counter-recoil mechanism.	
To measure the pressure and liquids in the counter-recoil system.	
To add gas to the counter-recoil mechanism.	
To add liquid to the counter-recoil mechanism.	
To add liquid to the recoil cylinder.	
Daily inspection.	
Instructions for repairs and replacements.....	136-150
Duties of the gun crew.	
To dismantle the firing mechanism.	
To assemble the firing mechanism.	
Dismantling the percussion mechanism.	
Assembling the percussion mechanism.	
Dismounting the cradle traveling locks.	
Assembling the cradle traveling locks.	
Dismounting the sleigh traveling locks.	
Assembling the sleigh traveling locks.	
Removing a carriage wheel.	
Replacing the wheel.	
Removing the caisson connecting pole.	
Replacing the connecting pole.	
Dismounting the pintle.	
Assembling the pintle.	
Removing a caisson wheel.	
Replacing the wheel.	
Removing a limber wheel.	
Replacing the wheel.	
Care of the sights.	
Duties of the battery mechanics.	
The howitzer.	
To dismantle the breech mechanism.	
To assemble the breech mechanism.	
Preparation of the liquid for the recoil and counter-recoil cylinders.	
Repairs and replacements.	
To dismount the firing mechanism.	
To assemble the firing mechanism.	
To dismount the elevating mechanism.	
To assemble the elevating mechanism.	
To dismount the traversing rollers.	
To assemble the traversing rollers.	
To dismount the traversing mechanism and axle.	
To assemble the axle and traversing mechanism.	
To dismount the axle traveling lock.	
To assemble the axle traveling lock.	
To dismount the spade.	

Instructions for repairs and replacements—Continued.	Page.
Duties of the battery mechanics—Continued.	
To assemble the spade.	
To dismantle the brake rigging.	
To assemble the brake rigging.	
To remove the brake band from the caisson.	
To replace the brake band.	
• To remove the supporting springs from the caisson.	
To replace the supporting springs.	
To remove the axle bracket from the caisson.	
To replace the axle bracket.	
Verification and adjustment of the sights.....	151-153
Additional tests.	
Verification and adjustment of the sights in the field.	
Verification and adjustment of the peep sight.	
Inspection by the battery mechanics.....	153-154
General notes on caring for the matériel.....	154-156
General information.....	156-158
Painting artillery matériel.	
Instructions for riveting.	
Cleaning and disinfecting of matériel affected by gas.....	158-160
Protection.	
Cleaning.	
Disinfecting.	
Protection against mustard gas.	
Transportation of artillery matériel affected by mustard gas.	
Repairs for field artillery matériel.....	160
PART III.—EQUIPMENT.	
Table of equipment.....	161-208
Abbreviations for motor vehicles.	
The units composing a regiment of 155-mm. howitzer matériel.	
Equipment.	
Index.....	209-216

## LIST OF PLATES.

Plate No.	Faces pag
1A. Right side view .....	1
1B. Traveling position .....	1
I. Howitzer .....	2
II. Breech mechanism .....	2
III. Breech mechanism .....	2
IV. Firing mechanism .....	2
V. 21-grain percussion primer .....	2
VI. Powder bags .....	2
VII. 155-mm. common steel shell, Mark I .....	2
VIII. 155-mm. common steel shell, Mark IV .....	2
IX. 155-mm. semisteel shell, Mark XVII .....	2
X. 155-mm. shrapnel, Mark I .....	3
XI. 45 second combination fuze, Mark I .....	3
XII. Adapter and booster, Mark IIIA .....	3
XIII. Adapter and booster casing, Mark VB .....	3
XIV. Adapter and booster, Mark VI .....	3
XV. Point detonating fuze, Mark IV .....	3
XVI. Point detonating fuze, Mark III .....	3
XVII. Hand fuze setter .....	3
XVIII. Left side elevation in battery .....	3
XIX. Left side view .....	3
XX. Traveling position .....	5
XXI. Longitudinal section in battery .....	5
XXII. Transverse section .....	5
XXIII. Gage cock with pressure-gage adapter assembled .....	5
XXIV. Recoil and counter-recoil mechanism .....	5
XXV. Piston-rod lock mechanism .....	5
XXVI. Recoil indicator .....	5
XXVII. Traversing rollers .....	5
XXVIII. Traversing mechanism .....	5
XXIX. Elevating mechanism .....	5
XXX. Axle traveling lock .....	5
XXXI. Firing mechanism .....	5
XXXII. Filling valve with air pump assembled .....	6
XXXIII. Air and liquid pumps .....	6
XXXIV. Quadrant sight (Schneider) .....	6
XXXV. Panoramic sight .....	6
XXXVI. 155-mm. howitzer carriage limber .....	7
XXXVII. Pole socket (limber) .....	7
XXXVIII. 155-mm. howitzer caisson, general views .....	8
XXXIX. 155-mm. howitzer caisson, limbered .....	8
XL. 155-mm. howitzer caisson, side elevations .....	9
XLI. Antiaircraft machine-gun trailer .....	9
XLII. Staff observation car .....	9
XLIII. Reconnaissance car .....	9

Plate No.	Faces page.
XXXVIII. Artillery tractor, 2½-ton.....	98
XXXIX. Artillery tractor, 5-ton.....	99
XL. Ammunition truck, 2-ton.....	104
XLI. Artillery repair truck.....	105
XLII. Artillery supply truck, 2-ton.....	108
XLIII. Light repair truck.....	109
XLIV. Reel.....	118
XLV. Cart.....	119
XLVI. Location of oil holes.....	132
XLVII. Target for testing sights.....	133

---

## TABLE OF EQUIVALENTS.

---

1 mil.....	3.37 minutes.
1 meter (m.).....	39.37 inches.
1 centimeter (cm.).....	.3937 inch.
1 millimeter (mm.).....	.03937 inch.
1 kilogram (kg.).....	2.2046 pounds.
1 dekagram (dkg.).....	.3527 ounce.
1 gram.....	15.432 grains.
1 liter.....	1.05671 quarts (U. S.).
1 inch.....	2.54 centimeters.
1 foot.....	.3048 meter.
1 yard.....	.9144 meter.
1 square inch.....	6.452 square centimeters.
1 cubic inch.....	16.39 cubic centimeters.
1 cubic foot.....	.02832 cubic meter.
1 cubic yard.....	.7645 cubic meter.
1 ounce.....	28.35 grams.
1 pound.....	.4536 kilogram.
1 quart (U. S.).....	.9463 liter.
1 degree.....	17.777 mils.
1 kilogram (kg.) per square centimeter.....	14.223 pounds per square inch.

## BRIEF DESCRIPTION OF THE 155-MM. HOWITZER MATÉRIEL MODEL OF 1917.

---

The 155-mm. howitzer carriage as manufactured in France is known as the 155-mm howitzer carriage, model of 1917, and as manufactured in the United States as the 155-mm. howitzer carriage, model of 1918 (Schneider). The American carriage differs from the French in having a straight shield instead of a curved one; rubber instead of steel tires; a slightly different firing mechanism; and several other minor changes. The howitzer is mounted on a carriage having a single trail composed of two pressed-steel flasks. At the front end, these are connected by the axle housing and at the rear by a fixed spade. The carriage embodies many ingenious features designed to reduce the weight and insure stability.

The recuperator is of the hydro-pneumatic type and recoils with the howitzer. In recoiling the liquid is forced from one side of the piston to the other through a variable orifice which gradually closes until the howitzer is brought to a stop. The return of the howitzer into battery is effected by the expansion of the air compressed during recoil. The length of recoil is constant, and in order to allow the howitzer to be fired at high elevations without digging in the trail, which is made U-shape.

By sliding transversely along its axle, the howitzer is capable of traversing through a total angle of 6°. Its maximum elevation is approximately 42°. It fires a 95-pound projectile with a muzzle velocity of about 1,480 feet per second to a maximum range of about 12,300 yards. Separate loading ammunition is employed. By the use of reduced powder charges, shorter ranges are reached with steep angles of fall and with less wear of the gun. Its life, before relining is necessary, is about 7,000 rounds.

The entire equipment is motorized and the equipment for each howitzer includes a carriage limber, used when traveling to support the trail, three caissons or ammunition vehicles, and an equal number of caisson limbers.

There are little differences between the 155-mm. howitzer carriage limber, model of 1917, of French manufacture, and the model of 1918 of United States manufacture. The following are the principal points in which the model of 1918 differs from the model of 1917.

(a) The draft spring along the side rails is omitted and the connecting pole substituted for the horse pole. The seat for the pole is left unchanged so that connecting poles can be substituted for horse poles on the limbers of French manufacture. Doubletree chain eyes are riveted to the side rails so that doubletrees may be attached should it be desired to use these limbers in horse-drawn batteries.

(b) A water bucket holder is added on the right side near the front and the picket rope hooks are shortened so that they do not project in rear of the axle.

(c) Steel-tired wheels are replaced by rubber-tired wheels but the hub boxes and wheel fastenings were not changed. Straps on the front rails were omitted.

(d) The electric lighting equipment was changed to the United States design and an additional bracket was added on the right side of the middle rail in order to carry two sets of this equipment.

The parts of the limbers and carriages are not entirely interchangeable, since for those manufactured in this country no French tolerances nor French gages were available. The nominal dimensions of the parts are, however, identical for the two models and it has been found that parts made in accordance with the United States drawings will interchange on matériel of French manufacture with very little hand fitting. (See tables on pages 21 and 23.)

## PART I.—DESCRIPTION OF THE MATÉRIEL.

### GENERAL DESCRIPTION.<sup>1</sup>

(Plates 1A and 1B.)

The 155-mm. howitzer, model of 1918 (Schneider) is of the hydro-pneumatic long-recoil type, which may be used for direct fire, but was specially designed for siege fire. On account of its high trajectory it is able to direct shells on targets inaccessible to standard 6-inch howitzers of limited elevation.

This howitzer has given satisfactory results in actual service and has proven to be more superior than guns of similar caliber. It has a muzzle velocity of 1,480 foot-seconds and at maximum elevation of fire it attains a maximum range of 12,300 yards, the projectile weighing about 95 pounds.

A maximum rate of fire of four or five rounds per minute may be attained, but heating as well as difficulty of preparing and transporting the ammunition by the gun crew renders such rate impossible for more than a few minutes. However, the normal rate of fire is two per minute and the howitzer may be loaded at any degree of elevation.

The howitzer is mounted on a sleigh and rigidly secured by means of a breech key and the holding-down band. The sleigh contains the recoil and recuperator mechanisms which permit long recoil and insure stability at low elevations. When the gun is fired the sleigh recoils on bronze slides on the cradle, which is a U-shaped steel plate and rests in the trunnion bearings of the trail.

This howitzer may be elevated from zero to 42° by means of the elevating mechanism. The traverse is 52.5 mils right and left, the carriage sliding on the axle and pivoting on the spade, which prevents the carriage recoiling when gun is fired. The customary shield protects the gunners from shrapnel and flying fragments.

In traveling position (Plate 1B) the howitzer is retracted and locked to the cradle, the cradle locked to the trail, the spade revolved and secured to bottom of the trail. The lower end of trail rests on the carriage limber, which is used to carry the proportionate share of the load of the howitzer and carriage in traveling position. The limber is equipped with a connecting pole for motor traction. The carriage and limber wheels are rubber-tired and considered able to negotiate any roads suitable for field artillery.

---

<sup>1</sup> For description of model 1917 matériel see page 12.

**THE HOWITZER.****WEIGHT, PRINCIPAL DIMENSIONS, ETC.**

Material.....	Alloy steel.
Weight (including breech mechanism).....	1,220 kg.=2,690 lbs.
Caliber.....	155 mm.=6.1 in.
Total length.....	2,332 mm.=91.8 in.
Length of bore.....	2,177 mm.=85.7 in.
Length of rifled portion of bore.....	1,737 mm.=68.4 in.
<b>Rifling:</b>	
Number of grooves.....	48.
Width of grooves.....	7.145 mm.=0.2813.
Depth of grooves.....	1 mm.=0.03937 in.
Width of lands.....	3 mm.=0.1181 in.
Twist, right hand, uniform, one turn in 25.586 calibers.	
<b>Powder chamber:</b>	
Diameter.....	158.75 mm.=6.25 in.
Length.....	339.85 mm.=13.38 in.
Volume.....	6,965.75 cu. cm.=425 cu. i
Obturation.....	Pad.
Firing mechanism.....	Percussion.

**NOMENCLATURE OF THE HOWITZER.**

(Property classification, Class IV, division 3.)

The battery personnel is directed to use the following nomenclature, giving piece marks and drawing numbers, when referring to parts of the howitzer in reports, correspondence, etc.

No. per gun.	Name of part.	Piece mark.	Drawing.		
			Class.	Division.	Number
<i>Howitzer.</i>					
1	Tube.....	10A.....	53	18	
1	Jacket.....	10C.....	53	18	
1	Counterweight.....	32B.....	53	18	
6	Counterweight screws.....	32A.....	53	18	
1	Breech key.....	35C.....	53	18	
1	Breech key set screw.....	35F.....	53	18	
1	Holding-down band.....	36A.....	53	18	
1	Howitzer bridle.....	35B.....	53	18	
2	Howitzer bridle fastening screw, long.....	35E.....	53	18	
2	Howitzer bridle fastening screw, short.....	35D.....	53	18	
2	Leveling plate.....	30A.....	53	18	
3	Lifting eye.....	32C.....	53	18	
3	Lifting eye locking screw.....	32D.....	53	18	
1	Regulating plate.....	11B.....	53	18	
3	Screws for holding-down band.....	36B.....	53	18	
1	Nut for regulating plate.....	11A.....	53	18	
<i>Breech mechanism.</i>					
1	Block carrier.....	13C.....	53	18	
1	Block carrier assembling stud.....	14A.....	53	18	
1	Block carrier hinge bearing plate.....	13A.....	53	18	
3	Block carrier hinge bearing plate screw.....	13B.....	53	18	
1	Block carrier lever catch.....	13D.....	53	18	
2	Block carrier lever catch screw.....	13E.....	53	18	
1	Breech block machined.....	28A.....	53	18	
1	Detent.....	16K.....	53	18	
1	Gas check pad.....	20A.....	53	18	
1	Obturator spindle.....	53A.....	53	18	



**155-mm. Howitzer Carriage, Model of 1918 (Schneider). Right Side View.**

PLATE 1

155 MM HOWITZER  
MODEL OF 1916  
(SCHNEIDER)

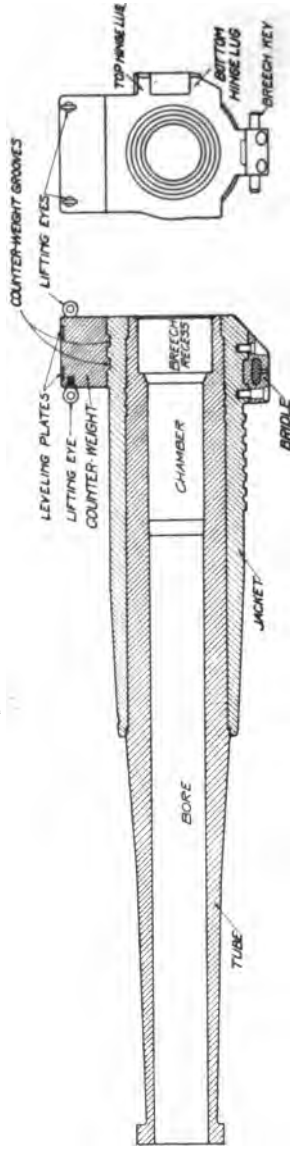
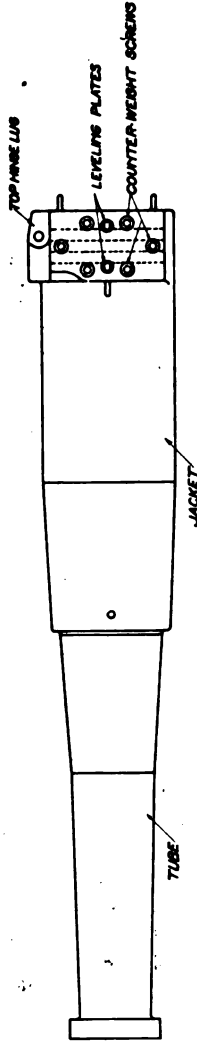

No. per gun.	Name of part.	Piece mark.	Drawing.		
			Class.	Division.	Number.
<i>Breech mechanism—Continued.</i>					
1	Obturator spindle spring .....	50E .....	53	18	50
1	Obturator spindle vent bushing .....	53B .....	53	18	53
1	Operating lever .....	15A .....	53	18	15
1	Operating lever catch .....	16F .....	53	18	16
1	Operating lever catch screw .....	16D .....	53	18	16
1	Operating lever collar .....	16C .....	53	18	16
1	Operating lever handle .....	16A .....	53	18	16
1	Operating lever handle key .....	16M .....	53	18	16
1	Operating lever handle nut .....	16G .....	53	18	16
1	Operating lever handle sleeve .....	16B .....	53	18	16
1	Operating lever handle spring .....	16H .....	53	18	16
1	Operating lever latch .....	16L .....	53	18	16
1	Operating lever latch plug .....	16E .....	53	18	16
1	Operating lever latch slot cover .....	15B .....	53	18	15
1	Operating lever latch slot cover screw .....	15C .....	53	18	15
1	Rack .....	23A .....	53	18	23
1	Rack lock .....	23C .....	53	18	23
1	Rack lock spring .....	23B .....	53	18	23
1	Spindle plug .....	53D .....	53	18	53
1	Spindle plug gasket .....	53C .....	53	18	53
1	Spindle spring front seat .....	50C .....	53	18	50
1	Spindle spring rear seat .....	50D .....	53	18	50
1	Split ring (front) .....	20C .....	53	18	20
1	Split ring (rear) .....	20D .....	53	18	20
1	Split ring (small) .....	20E .....	53	18	20
<i>Firing mechanism.</i>					
1	Firing mechanism block .....	52B .....	53	18	52
1	Firing mechanism block handle .....	52C1 .....	53	18	52
1	Firing mechanism block latch .....	48A1 .....	53	18	48
1	Firing mechanism block latch holder .....	48D1 .....	53	18	48
4	Firing mechanism block latch holder screw .....	48E1 .....	53	18	48
1	Firing mechanism block latch handle .....	48F1 .....	53	18	48
1	Firing mechanism block latch spring .....	48C1 .....	53	18	48
1	Firing mechanism housing .....	50B .....	53	18	50
1	Firing mechanism housing key .....	50F .....	53	18	50
1	Firing mechanism housing key spring .....	50G .....	53	18	50
1	Firing mechanism housing key spring rivet .....	50L .....	53	18	50
1	Firing mechanism housing key spring stud .....	50H .....	53	18	50
1	Firing mechanism housing screw .....	50A .....	53	18	50
1	Firing mechanism safety plunger .....	50K .....	53	18	50
1	Firing mechanism safety plunger spring .....	50M .....	53	18	50
1	Firing pin .....	51C1 .....	53	18	51
1	Firing pin guide .....	51A1 .....	53	18	51
1	Firing pin housing .....	52A1 .....	53	18	52
1	Firing pin housing holding screw .....	52D1 .....	53	18	52
1	Firing pin spring .....	51D1 .....	53	18	51
1	Percussion hammer .....	24A .....	53	18	24
1	Percussion hammer lock bolt .....	22F .....	53	18	22
1	Percussion hammer lock bolt spring .....	22D .....	53	18	22
1	Percussion hammer lock bolt spring set screw .....	22G .....	53	18	22
1	Percussion hammer lock housing .....	22N .....	53	18	22
3	Percussion hammer lock housing screw .....	22C .....	53	18	22
1	Percussion hammer lock housing set screw .....	22P .....	53	18	22
1	Percussion hammer operating shaft .....	22A .....	53	18	22
1	Percussion hammer operating shaft collar .....	22H .....	53	18	22
1	Percussion hammer operating shaft housing .....	22E .....	53	18	22
2	Percussion hammer operating shaft housing control screw .....	22M .....	53	18	22
1	Percussion hammer operating shaft nut .....	22B .....	53	18	22
1	Percussion hammer shaft plunger .....	22L .....	53	18	22
1	Percussion hammer shaft plunger spring .....	22K .....	53	18	22
1	Primer seat plug .....	51B .....	53	18	51

## DESCRIPTION OF THE HOWITZER.

## THE HOWITZER.

The howitzer, Plate I, consists of a tube and jacket. The jacket is shrunk over, approximately, the rear half of the tube and screwed to it by a short thread near the rear end of the tube. The rear

end of the tube is prepared for the reception of the breechblock. On the right of the jacket at its rear end are two lugs which receive the hinge pintle of the operating lever. A flat seat with two transverse slots is machined on top of the jacket at the rear end for receiving the counterweight. The counterweight is securely fastened to the jacket by six screws, and two lugs which engage the slots in the jacket. The bridle is fitted to the under side of the jacket near the rear end and held in place by four screws. The breech key passes through the bridle and holds the howitzer in its seat on the sleigh. On the under side of the jacket just forward of the bridle seat are seven square threads which engage corresponding threads on the sleigh. A holding-down band which encircles the jacket at its forward end also secures the howitzer to the sleigh.

On the top surface of the counterweight are two nickel-silver leveling plates.

Vertical and horizontal axis lines are cut on the breech and muzzle faces. A line showing the actual center of gravity with the breech mechanism in place is cut on the upper side of the jacket marked C. of G. The name and model of the howitzer are stamped on the left side of the jacket just below the counterweight. The name of the manufacturer, year of manufacture, serial number of the howitzer, and the weight of howitzer, including the breech mechanism, are stamped on the muzzle face.

#### THE BREECH MECHANISM.

The breech mechanism, Plates II and III, is of the plastic obturator interrupted screw type, having four plain sectors and four threaded sectors. The block can be locked with one-eighth of a turn. Two of the plain sectors are relieved to permit the breechblock to enter the breech recess. The breechblock is screwed into the block carrier and rides on the hub of the latter.

The block carrier is hinged to the right side of the jacket by means of the pintle hinge of the operating lever.

The pintle hinge is fitted at the lower end with an operating lever collar and detent. The dead weight of the breech is carried by the block carrier hinge plate.

The block is rotated by means of a rack which engages teeth cut in the upper surface of the block at its rear end. The rack is actuated by a lug on the under side of the operating lever which engages a slot in the rack. The rack lock is located in the inside face of the block carrier. When the breech is tightly closed this lock bears against the breech face of the howitzer and is forced back against the rack lock spring, leaving the rack free to move

As the breech starts to open the rack lock is forced up by its spring and locks the rack, preventing further rotary motion of the breechblock.

The operating lever is provided with an operating lever handle which is kept in its raised position by the operating lever handle spring. When the breech is closed and locked the lower portion of the operating lever handle engages the block carrier lever catch. When the breech is fully open the operating lever latch which extends through the operating lever, engages the operating lever catch and holds the breech in that position.

The obturator spindle is of the mushroom head type. It passes through the center of the breechblock and is screwed into the front end of the firing mechanism housing, which fits into the hub of the block carrier. The obturator spindle is prevented from turning by the firing mechanism housing key, which is held in place by the firing mechanism housing key spring. A vent for the passage of the primer flame is drilled through the center of the obturator spindle. The obturator spindle bushing is screwed into the front end of the obturator spindle and the obturator spindle plug into the rear end, the latter forming a chamber for the primer.

The obturator spindle spring bears against the firing mechanism housing and the breechblock, keeping the head of the obturator spindle tightly against the gas check pad. The gas check pad or plastic obturator is composed of a mixture of one part asbestos and three parts nonfluid oil, contained in a canvas covering. The pad is protected by the front, rear and small split rings. A steel filling-in disk is placed between the gas check pad and the breechblock.

#### THE FIRING MECHANISM.

The firing mechanism housing, Plate IV, is provided with a firing mechanism safety plunger which is forced by the firing mechanism safety plunger spring against the inside circumference of a circular boss on the face of the breechblock. When the breechblock is rotated to its locked position, the plunger slips into a notch in the boss and permits the entrance of the firing mechanism block. When the breech is unlocked, the lower end of the firing mechanism safety plunger extends into the firing mechanism housing and obstructs the entrance of the firing mechanism block. This safety device makes it impossible to unlock the breech while the firing mechanism block is in place or to insert the firing mechanism block while the breech is unlocked.

The firing mechanism block is provided with a handle, and screws into the firing mechanism housing. The primer seat plug is screwed into the front end of the firing mechanism block and is provided

with a notch into which the primer is inserted. The firing pin guide is located just back of the primer seat plug and forms a guide for the firing pin as well as a bearing for the firing pin spring. The firing pin housing is screwed into the rear end of the firing mechanism block and held in place by the firing pin housing holding screw. The firing pin passes through the firing pin housing and the firing pin guide and is forced to the rear by the firing pin spring. The firing mechanism block is provided with a flange at its outer edge in which a slot is cut to receive a projection on the front of the percussion hammer. This prevents the hammer from striking the firing pin when the firing mechanism block is not screwed home. The firing mechanism block latch is located on the outer face of the block carrier and prevents the firing mechanism block from being unscrewed accidentally.

The firing mechanism block is interchangeable with the firing mechanism blocks used on the following cannon:

155-mm. gun, model of 1918 MI (Filloux).

8-inch howitzer, model of 1917 (Vickers Mark VI and VIII $\frac{1}{2}$ ).

240-mm. howitzer, model of 1918 and model 1918 MI (Schneider).

#### THE PERCUSSION MECHANISM.

The percussion hammer, Plate II, is carried by the percussion hammer operating shaft which is journaled in the percussion hammer operating shaft housing. This housing is secured to the breech face by means of a dovetail projection which fits into a slot, cut across the entire breech face just below the breech opening. The percussion hammer operating shaft is fitted with a lever at its right end which receives the blow of the firing mechanism striker when the lanyard is pulled. The percussion hammer shaft plunger and spring are located in the percussion hammer operating shaft housing to the left of the hammer. When the breech is open the plunger is forced up by its spring, thereby causing a projection on the plunger to engage in a recess in the operating shaft, locking the shaft so that the hammer can not be operated. When the breech is closed the under side of the block carrier strikes the beveled head of the shaft plunger, forcing it down and thus unlocking the mechanism.

The percussion hammer lock bolt is screwed to the face of the carrier to the left of the percussion hammer. Its function is to lock the hammer in the traveling position when the howitzer is not in use.

#### OPERATION OF THE BREECH MECHANISM.

When the breech is closed and locked, the threaded portions of the breechblock mesh with the threads in the breech recess. The operating lever is held by the lower end of the operating lever han-

dle which engages the block carrier lever catch, thus preventing any rotary motion of the breechblock at the instant of firing. The firing pin receives the blow of the percussion hammer and fires the primer. The flame passes through the vent in the obturator spindle, igniting the propelling charge. The gas pressure in the bore forces the mushroom head of the obturator spindle hard against the gas check pad, causing the latter to expand and press against the walls of the chamber, forming a gas-tight joint. After the explosion the elasticity of the pad causes it to resume its former shape, allowing the obturator to be withdrawn freely from its seat when the breech is unlocked.

#### TO OPEN THE BREECH.

After the piece has been fired, and before unlocking the breech, press back the firing mechanism block safety latch, screw out the firing mechanism block and remove the used primer. The breech can not be unlocked with the firing mechanism block in place. An attempt to do so will result in jamming of the firing mechanism safety plunger. It is therefore important that the firing mechanism block should be removed before attempting to unlock the breech.

Press down on the handle of the operating lever in order to disengage it from the block carrier lever catch. Move the lever toward the rear and then to the right. In the first part of this movement, the operating lever turns freely around the hinge pin and its lug operates the rack which turns the breechblock. The threaded parts of the breechblock are thus disengaged from the threads in the breech recess. As the rack reaches the limit of its travel, the block carrier is swung on its hinge, drawing the breechblock out of the breech recess. As the block carrier leaves the breech face of the howitzer the rack lock is forced by its spring into the recess in the rack, preventing any further rotary motion of the breechblock in either direction. As the breech reaches its full open position, the right end of the operating lever latch engages the operating lever catch, locking the breech in open position.

In loading care should be taken to ram the projectile home and to enter the propelling charge in such a way that the igniter of the base charge, Plate V, will be in contact with the mushroom head of the obturator spindle when the breech is closed.

#### TO CLOSE THE BREECH.

Press down on the operating lever handle to disengage the operating lever latch from the operating lever catch and move the operating lever to the left and forward. As the block carrier comes in contact with the breech face of the howitzer, the rack lock is pushed back into its seat, freeing the rack. Further movement of the operat-

ing lever forces the rack to the left, rotating the breechblock until its threaded portions mesh with the threads in the breech recess. At the end of the movement of the operating lever, the operating lever handle engages the block carrier lever catch and fastens the breech in locked position.

Insert a new primer in the primer seat plug and replace the firing mechanism block. The firing mechanism block can not be entered until the breech is closed and locked. Any attempt to do so may cause damage to the firing mechanism safety plunger or some part of the firing mechanism.

#### • MISFIRES.

Misfires may be caused by either missing of the primer or missing of the charge.

##### MISSING OF THE PRIMER.

Missing of the primer may be attributed to either a defective primer or failure of the firing pin to strike the cap of the primer properly. If the primer fails to act, unscrew the firing mechanism block and examine the primer. If there is evidence that the cap has received the blow of the firing pin, discard the primer and insert a new one.

If the cap has not been properly indented it is probable that the action of the firing pin has been impeded by dirt or powder residue collected inside of the firing mechanism block. In this case it will be necessary to dismantle the firing mechanism block and carefully clean and examine each part. If any parts are worn or damaged, replace them with new parts. Reassemble the mechanism and try the primer again.

##### MISSING OF THE CHARGE.

Should the primer act without affecting the propelling charge, only the report of the primer will be heard. Failure of the propelling charge to ignite may be attributed to one or more of the following causes: Dirt or dampness in the vent, failure of the igniter of the charge to bear against the mushroom head, or dampness in the charge itself.

After a misfire of the charge a period of not less than one minute should elapse before approaching the breech. Remove the firing mechanism block, clean the vent with the tool provided for that purpose and insert a new primer. If the charge does not fire the second time, allow a period of two minutes to elapse and open the breech. If on examination the charge appears to have been properly loaded, it should be discarded.

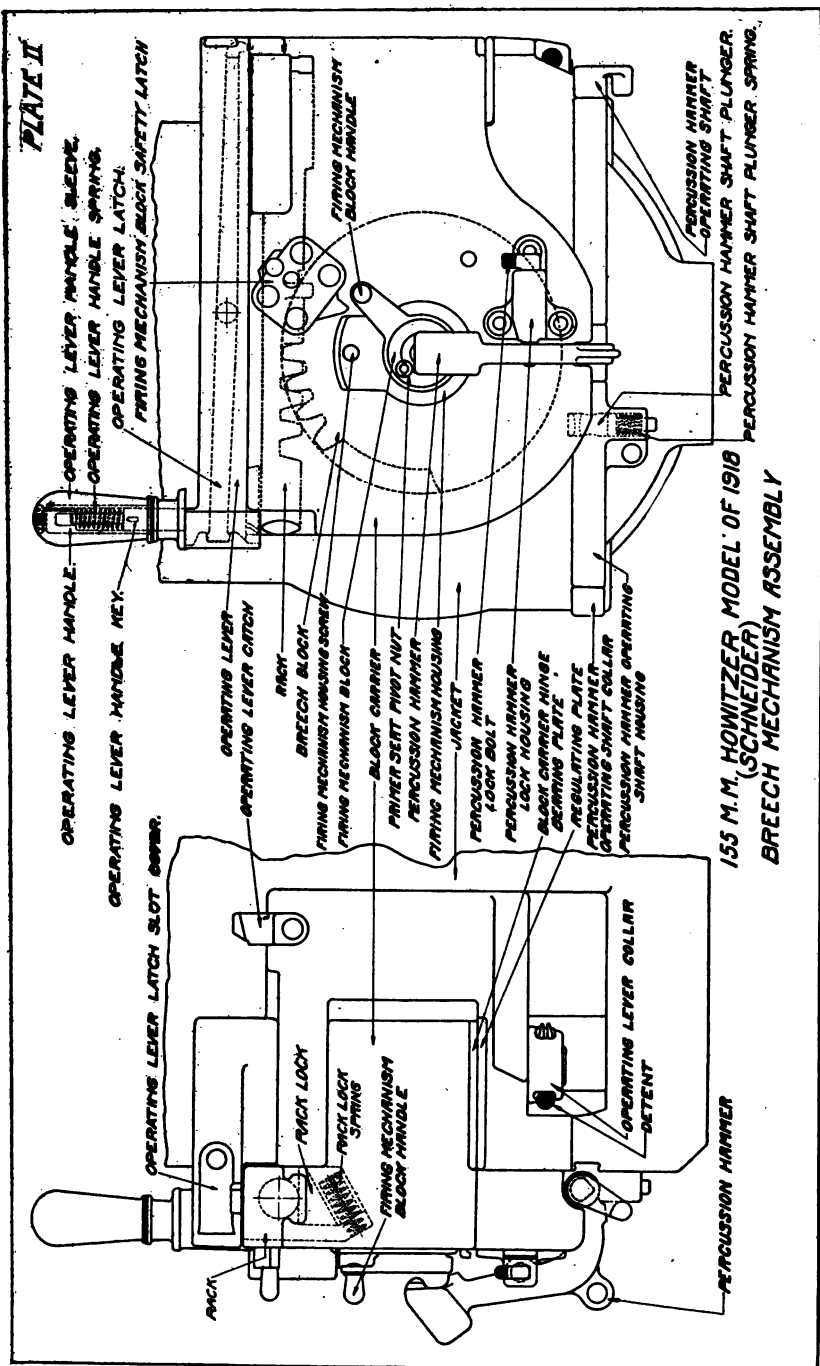

**PLATE III**

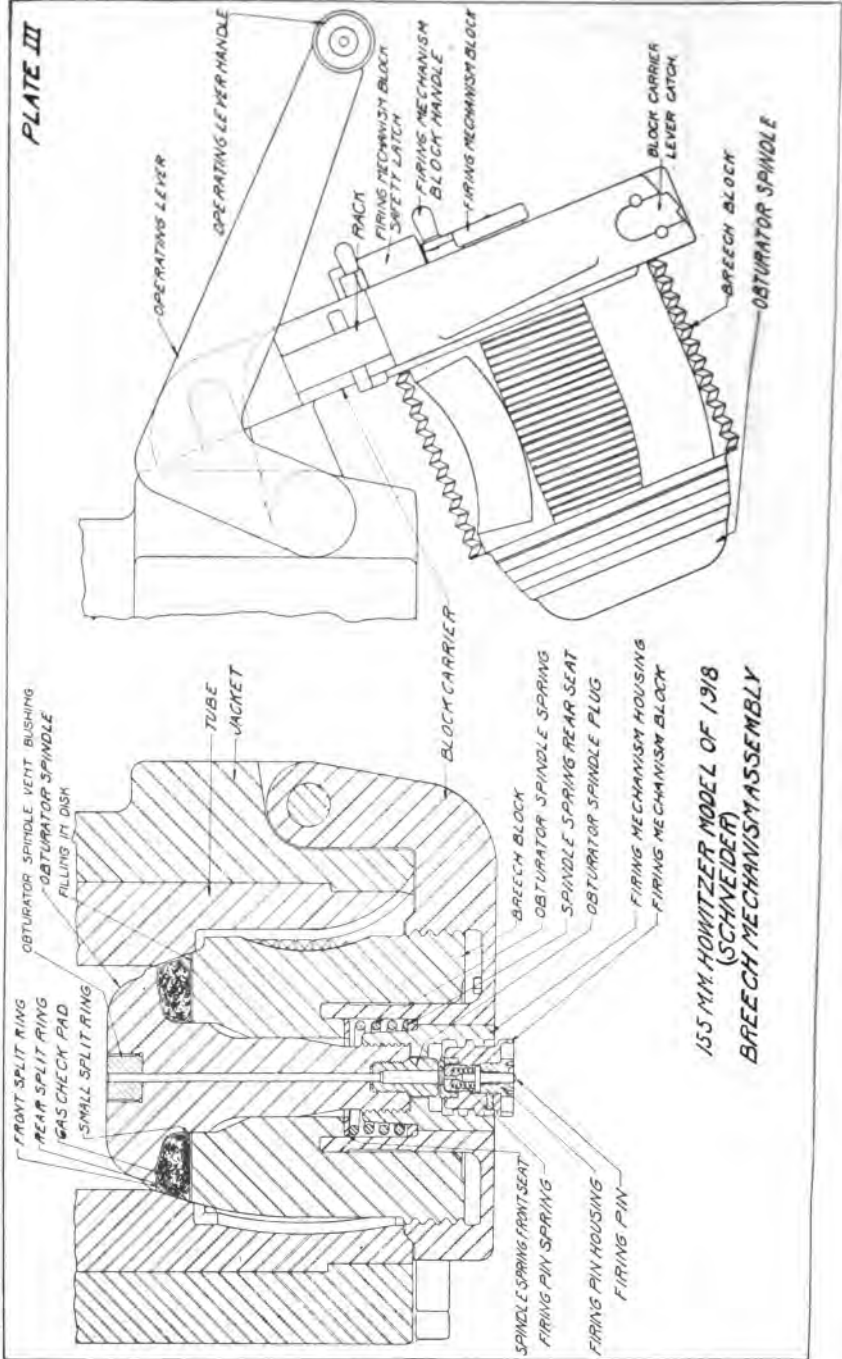

155 MM HOWITZER MODEL OF 1918  
(SCHNEIDER)  
BREECH MECHANISM ASSEMBLY

Table showing spare and replacement parts which are furnished; interchangeable for all 155-mm. howitzers, model of 1918 (Schneider).

Name of part.	Piece mark.	Drawing.		
		Class.	Division.	Number.
Block carrier hinge bearing plate.....	13A.....	53	18	13
Block carrier hinge bearing plate screw.....	13B.....	53	18	13
Block carrier.....	13C.....	53	18	13
Breech key.....	35C.....	53	18	35
Breech key set screw.....	35F.....	53	18	35
Breechblock assembling stud.....	28B.....	53	18	28
Breechblock.....	28A.....	53	18	28
Detent.....	16K.....	53	18	16
Firing mechanism block latch.....	48A1.....	53	18	48
Firing mechanism block latch spring.....	48C1.....	53	18	48
Firing mechanism block latch holder.....	48D1.....	53	18	48
Firing mechanism block latch handle.....	48F1.....	53	18	48
Firing mechanism housing.....	50B.....	53	18	50
Firing mechanism housing key.....	50F.....	53	18	50
Firing mechanism housing key spring.....	50G.....	53	18	50
Firing mechanism housing key spring stud.....	50H.....	53	18	50
Firing mechanism safety plunger.....	50K.....	53	18	50
Firing mechanism housing key spring rivet.....	50L.....	53	18	50
Firing mechanism safety plunger spring.....	50M.....	53	18	50
Firing pin guide.....	51A1.....	53	18	51
Firing pin.....	51C1.....	53	18	51
Firing pin spring.....	51D1.....	53	18	51
Firing pin housing.....	52A1.....	53	18	52
Firing mechanism block.....	52B.....	53	18	52
Firing mechanism block handle.....	52C1.....	53	18	52
Firing pin housing holding screw.....	52D1.....	53	18	52
Filling-in disk.....	20B.....	53	18	20
Front split ring.....	20C.....	53	18	20
Gas check pad.....	20A.....	53	18	20
Holding-down band screw.....	36B.....	53	18	36
Lifting eye lock screw.....	32D.....	53	18	32
Nut for regulating plate.....	11A.....	53	18	11
Operating lever.....	15A.....	53	18	15
Operating lever handle.....	16A.....	53	18	16
Operating lever handle sleeve.....	16B.....	53	18	16
Operating lever collar.....	16C.....	53	18	16
Operating lever handle nut.....	16G.....	53	18	16
Operating lever handle spring.....	16H.....	53	18	16
Operating lever latch.....	16L.....	53	18	16
Operating lever handle key.....	16M.....	53	18	16
Obturator spindle spring.....	50E.....	53	18	50
Obturator spindle.....	53A.....	53	18	53
Percussion hammer operating shaft.....	22A.....	53	18	22
Percussion hammer operating shaft nut.....	22B.....	53	18	22
Percussion hammer lock bolt spring.....	22D.....	53	18	22
Percussion hammer lock bolt.....	22F.....	53	18	22
Percussion hammer lock bolt spring set screw.....	22G.....	53	18	22
Percussion hammer operating shaft collar.....	22H.....	53	18	22
Percussion hammer shaft plunger spring.....	22K.....	53	18	22
Percussion hammer shaft plunger.....	22L.....	53	18	22
Percussion hammer lock housing.....	22N.....	53	18	22
Percussion hammer lock housing set screw.....	22P.....	53	18	22
Percussion hammer.....	24A.....	53	18	24
Primer seat plug.....	51B.....	53	18	51
Rear split ring.....	20D.....	53	18	20
Rack.....	23A.....	53	18	23
Rack lock spring.....	23B.....	53	18	23
Rack lock.....	23C.....	53	18	23
Small split ring.....	20E.....	53	18	20
Spindle spring front seat.....	50C.....	53	18	50
Spindle spring rear seat.....	50D.....	53	18	50
Spindle plug.....	53D.....	53	18	53

Table showing spare and reserve parts for the 155-mm. howitzer, model of 1918 (Schneider) which require fitting at the base depot.

Piece mark.	Drawing.			Name of part.
	Class.	Division.	Number.	
11B.....	53	18	11	Regulating plate. The surface marked on drawing, "allow for fitting," is made slightly oversize, and must be ground to match the seat in the hinge lug. This part is casehardened.
13D.....	53	18	13	Block carrier lever catch. Sides and catch surface must be fitted to the carrier. This part is not casehardened.
15B.....	53	18	15	Operating lever latch slot cover. Sufficient stock is allowed on the sides for fitting. This part is not casehardened.
14A.....	53	18	14	Block carrier assembling stud. Furnished with round head; after riveting onto place it must be flattened on the side to the desired angle.
16F.....	53	18	16	Operating lever catch. Sides and catch surface must be fitted to its seat and latch. Not casehardened.
53B.....	53	18	53	Obturator spindle vent bushing. Furnished with surplus metal on the end for applying a wrench, and the hole is not drilled; it must be finished after inserting in its seat.
53C.....	53	18	53	Spindle plug gasket. Must be drilled after assembling.
22E.....	53	18	22	Percussion hammer operating shaft housing. Dovetailed sides must be fitted to its seat in the howitzer.
30A.....	53	18	30	Leveling plate. Furnished in the form of a disk to be riveted into its seat, after which it must be finished flush with the top surface of the counterweight parallel to the axle of the bore. The lines should be marked as shown on drawing.
32B.....	53	18	32	Counterweight of howitzer. Surface must be fitted tightly to its seat. Lifting eyes and locking screws are assembled with the counterweight. Levelling plates are riveted in place and finished flush with top surface, but not marked.
32C.....	53	18	32	Lifting eye. Must be fitted into the counterweight, facing the shoulder if necessary, and then fitting the securing screw.
35B.....	53	18	35	Howitzer bridle. The bottom of the breech key slot must be filed to permit fitting of the key to the carriage sleigh. The boss on the top of the bridle is turned one sixty-fourth oversize to permit fitting to the counterbore seat.
36A.....	53	18	36	<p>           Holding-down band. The holes for the holding-down band screws and the taper seat for the band clip bolts must be fitted after it is assembled on the gun and sleigh.            The following parts are furnished with surplus stock on the head of the screw, to be cut off and finished flush after assembling:         </p>
13E.....	53	18	13	Block carrier catch screw.
15C.....	53	18	15	Operating lever latch slot cover screw.
16D.....	53	18	16	Operating lever catch screw.
16E.....	53	18	16	Operating lever latch plug.
22C.....	53	18	22	Percussion hammer lock housing screw.
22M.....	53	18	22	Percussion hammer operating shaft housing control screw.
32A.....	53	18	32	Counterweight screw.
35D.....	53	18	35	Howitzer bridle fastening screw (short head).
35E.....	53	18	35	Howitzer bridle fastening screw (long head).
48E.....	53	18	48	Firing mechanism block latch holder screw.
50A.....	53	18	50	Firing mechanism housing screw.

Table showing interchangeability of spare and replacement parts for the 155-mm. howitzer, model of 1918 (Schneider), with 155-mm. howitzer, model of 1917 (Schneider), French.

No.	Drawing.			Name of part.	Interchangeable with French design.	Remarks.
	Class.	Division.	No.			
10B	53	18	10	Breechblock	Yes	
13A	53	18	13	Block carrier hinge bearing plate <sup>1</sup>	No	Different thread.
13B	53	18	13	Block carrier hinge bearing plate screw <sup>1</sup>	No	Do.
13C	53	18	13	Block carrier <sup>1</sup>	No	Do.
13D	53	18	13	Block carrier lever catch <sup>1</sup>	Yes	
13E	53	18	13	Block carrier lever catch screw <sup>1</sup>	No	Do.
14A	53	18	14	Block carrier assembling stud <sup>1</sup>	No	Do.
35C	53	18	35	Breech key	Yes	
35F	53	18	35	Breech key set screw <sup>1</sup>	No	Do.
28B	53	18	28	Breechblock assembling stud <sup>1</sup>	No	Do.
32A	53	18	32	Counterweight screws <sup>1</sup>	No	Do.
32B	53	18	32	Counterweight of howitzer <sup>1</sup>	No	Do.
16K	53	18	16	Detent <sup>1</sup>	Yes	
48A	53	18	48	Firing mechanism block latch	No	Different design.
48C	53	18	48	Firing mechanism block latch spring	No	Do.
48D	53	18	48	Firing mechanism block latch holder	No	Do.
48E	53	18	48	Firing mechanism block latch holder screw	No	Do.
48F	53	18	48	Firing mechanism block latch handle	No	Do.
50A	53	18	50	Firing mechanism housing screw	No	Do.
50B	53	18	50	Firing mechanism housing	No	Do.
50F	53	18	50	Firing mechanism housing key	No	Do.
50G	53	18	50	Firing mechanism housing key spring	No	Do.
50H	53	18	50	Firing mechanism housing key spring stud	No	Do.
50K	53	18	50	Firing mechanism safety plunger	No	Do.
50L	53	18	50	Firing mechanism housing key spring rivet	No	Do.
50M	53	18	50	Firing mechanism safety plunger spring	No	Do.
51A	53	18	51	Firing pin guide <sup>1</sup>	No	Different thread.
51C	53	18	51	Firing pin	No	Different design.
51D	53	18	51	Firing pin spring <sup>1</sup>	No	Different thread.
52A	53	18	52	Firing pin housing	No	Different design.
52B	53	18	52	Firing mechanism block	No	Do.
52C	53	18	52	Firing mechanism block handle	No	Do.
52D	53	18	52	Firing pin housing holding screw	No	Do.
20B	53	18	20	Filling-in disc	Yes	
20C	53	18	20	Front split ring	Yes	
20A	53	18	20	Gas check pad	Yes	
35B	53	18	35	Howitzer bridle <sup>1</sup>	No	Different thread.
35D	53	18	36	Howitzer bridle fastening screw (short head) <sup>1</sup>	No	Do.
35E	53	18	35	Howitzer bridle fastening screw (long head) <sup>1</sup>	No	Do.
36A	53	18	36	Holding-down band <sup>1</sup>	No	Do.
36B	53	18	36	Holding-down band screw	No	Do.
30A	53	18	30	Leveling plate	Yes	
32C	53	18	32	Lifting eye	No	Not used on French design.
32D	53	18	32	Lifting eye lock screw	No	Do.
11A	53	18	11	Nut for regulating plate <sup>1</sup>	No	Different thread.
15A	53	18	15	Operating lever	Yes	
15B	53	18	15	Operating lever latch slot cover <sup>1</sup>	No	Do.
15C	53	18	15	Operating lever latch slot cover screw <sup>1</sup>	No	Do.
16A	53	18	16	Operating lever handle <sup>1</sup>	No	Do.
16B	53	18	16	Operating lever handle sleeve	Yes	
16C	53	18	16	Operating lever collar	Yes	
16D	53	18	16	Operating lever catch screw <sup>1</sup>	No	Do.
16E	53	18	16	Operating lever latch plug <sup>1</sup>	No	Do.
16F	53	18	16	Operating lever catch <sup>1</sup>	No	Do.
16G	53	18	16	Operating lever handle nut <sup>1</sup>	No	Do.
16H	53	18	16	Operating lever handle spring	No	Do.
16L	53	18	16	Operating lever latch	No	Different design.
16M	53	18	16	Operating lever handle key	No	Do.
50E	53	18	50	Obturator spindle spring	No	Do.
53A	53	18	53	Obturator spindle	No	Do.
53B	53	18	53	Obturator spindle vent bushing	Yes	
22A	53	18	22	Percussion hammer operating shaft	Yes	
22B	53	18	22	Percussion hammer operating shaft nut	Yes	
22C	53	18	22	Percussion hammer lock housing screw <sup>1</sup>	No	Different thread.
22D	53	18	22	Percussion hammer lock bolt spring	Yes	

<sup>1</sup> United States standard thread used on parts for 155-mm. howitzer, model of 1918 (Schneider), instead of international standard as used on French design.

Table showing interchangeability of spare and replacement parts for the 155-mm. howitzer, model of 1918 (Schneider), with 155-mm. howitzer, model of 1917 (Schneider), French—Continued.

No.	Drawing.			Name of part.	Interchangeable with French design.	Remarks.
	Class.	Division.	No.			
22E.....	53	18	22	Percussion hammer operating shaft housing.	Yes.....	
22F.....	53	18	22	Percussion hammer lock bolt.....	Yes.....	Different thread.
22G.....	53	18	22	Percussion hammer lock bolt set screw <sup>1</sup>	No.....	
22H.....	53	18	22	Percussion hammer operating shaft collar.	Yes.....	
22K.....	53	18	22	Percussion hammer shaft plunger spring.	Yes.....	
22L.....	53	18	22	Percussion hammer shaft plunger.....	Yes.....	Do.
22M.....	53	18	22	Percussion hammer operating shaft housing control screw. <sup>1</sup>	No.....	
22N.....	53	18	22	Percussion hammer lock housing <sup>1</sup> .....	No.....	Do.
22P.....	53	18	22	Percussion hammer lock housing set screw. <sup>1</sup>	No.....	Do.
24A.....	53	18	24	Percussion hammer.....	Yes.....	Different design.
51B.....	53	18	51	Primer seat plug <sup>1</sup> .....	No.....	
20D.....	53	18	20	Rear split ring.....	Yes.....	
23A.....	53	18	23	Rack.....	Yes.....	
23B.....	53	18	23	Rack locking spring.....	Yes.....	
23C.....	53	18	23	Rack lock.....	Yes.....	
11B.....	53	18	11	Regulating plate.....	Yes.....	
20E.....	53	18	20	Small split ring.....	Yes.....	
50C.....	53	18	50	Spindle spring front seat.....	Yes.....	
50D.....	53	18	50	Spindle spring rear seat.....	Yes.....	
53C.....	53	18	53	Spindle plug gasket.....	Yes.....	
53D.....	53	18	53	Spindle plug.....	No.....	

<sup>1</sup> United States standard thread used on parts for 155-mm. howitzer, model of 1918 (Schneider), instead of international standard as used on French design.

The above list applies only to 155-mm. howitzers, model of 1917 (Schneider), French design, which have been equipped with firing mechanism and safety device shown on French Government drawing No. 7000E.

A complete breech mechanism (including percussion and firing mechanism) for the 155-mm. howitzer, model of 1918 (Schneider), may be assembled on the 155-mm. howitzer, model of 1917 (Schneider), French design, except that the percussion hammer operating shaft housing control screws must be made with metric thread to fit existing holes in the French howitzers.

#### AMMUNITION.

Separate loading ammunition is used in the 155-mm. howitzer, model of 1918 (Schneider). Three types of projectiles are issued by the Ordnance Department—high explosive common steel shell, gas shell, and shrapnel. The howitzer is also designed to fire the French long shell (obus allonge). High explosive and gas shells are issued filled, but unfuzed, the fuze hole closed with a suitable plug. The cavities of all projectiles are lacquered to diminish the danger of premature ignition of the bursting charge from friction and the exteriors are painted with distinctive colors prescribed by the Ordnance Department. The weight of the projectile is 95 pounds. The

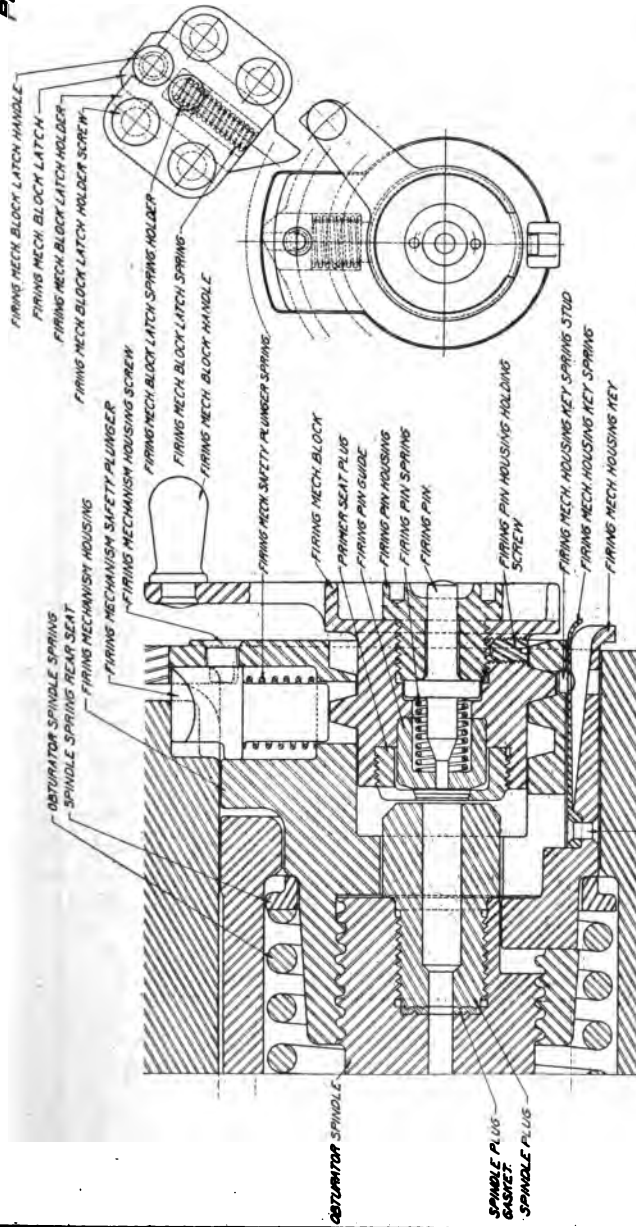

155 MM HOWITZER MODEL OF 1918  
(SCHNEIDER)  
FIRING MECHANISM

PLATE V

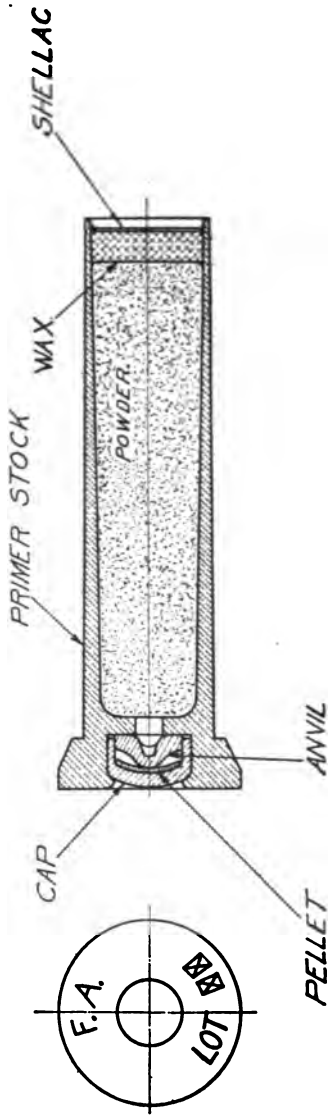

21 GRAIN PERCUSSION PRIMER MARK IIA

total weight of each round is approximately 103 pounds. The components of each round are the primer, the propelling charge, projectile, and fuze.

#### THE PRIMER.

The howitzer is designed to use the 21-grain percussion primer, Mark IIA, Plate V. This primer has no exterior thread and is held in its seat by the firing mechanism. It consists of a brass case resembling in shape a small-arms cartridge case. The head, or rear end, of the primer is countersunk, forming a cup-shaped recess, in which the percussion primer proper is fitted. The latter consists of a cap, percussion composition, and anvil. The percussion composition contains the following ingredients:

	Per cent.
Fulminate of mercury.....	35
Chlorate of potash.....	35
Sulphide of antimony.....	30

The percussion cap recess is connected with the interior of the primer case by a small vent. The body of the case contains 21 grains of black powder, which is inserted under sufficient pressure to retain it in the primer. A layer of composition wax is used to seal the end. The outside surface of the wax is covered with a layer of shellac to insure water-tightness.

In action the blow of the firing pin of the breech mechanism explodes the percussion cap, which ignites the black powder. The flames of the latter shoot out and ignite the auxiliary charge of black powder in the cartridge, which in turn ignites the smokeless powder charge.

#### THE CARTRIDGE.

The propelling charge of smokeless powder, Plate VI, is a sectionized charge consisting of a base charge and six smaller increments corresponding to the seven zones of fire, and marked accordingly.

The bags are made of cartridge cloth, and tied together as shown on Plate VI. The total cartridge of seven bags occupies practically the full length and diameter of the powder chamber and weighs approximately 8 pounds. A small igniting charge of black powder is inserted at both ends and at the center of the base charge and at the center of each of the incremental charges. The total weight of black powder is approximately 3 ounces.

The full charge is used for maximum range firing, and as ranges in inner zones are desired one or more of the sections of the charge are removed.

The powder composing the propelling charge is a nitrocellulose powder consisting of multiperforated cylindrical grains. The weight of the charge varies slightly for different lots of powder, but is approxi-

mately 8 pounds. The weight is determined from the acceptance test of the powder lot, which also gives the standard muzzle velocity of that particular lot of powder.

#### COMMON STEEL SHELL, MARK I.

The common steel shell, Plate VII, has a total length of 22.7 inches unfuzed and 24.58 inches fuzed. It has an ogival head struck with a radius of 65.47 inches, and is fitted with a copper rotating band forced into an undercut seat 3.23 inches from the base of the shell. The bottom of the band seat in the shell is roughened to prevent slipping of the band. The base of the shell is solid and is fitted with a base cover consisting of a lead disk and copper cover, which are calked into a circular undercut groove in the shell base with lead calking wire. This cover is to prevent leakage of flame from the propelling charge through the shell base, which might cause premature explosion of the shell in the bore of the howitzer.

Its capacity unfuzed is 272,307 cubic inches, and fuzed 265,535 cubic inches.

The shell contains a bursting charge of approximately 15.2 pounds of cast trinitrotoluol. An adapter for receiving the fuze, which contains a booster, is screwed into the nose of the shell.

The exterior surfaces of common steel shells are painted yellow.

#### GAS SHELL, MARK II.

The body of the gas shell is identical with the common steel shell Mark I, except that it has no base cover, and the tapped hole to receive the adapter is tapered to make a gas-tight joint. The gas is liquefied by cooling and poured into the shell. A sufficient space is left to allow for expansion when the gas regains atmospheric temperature. The screwing in of the adapter seals the gas hermetically in the shell cavity.

A booster charge similar to the one used to explode the common steel shell is located in the adapter and is sufficient to open the nose of the shell and release the gas. An instantaneous point detonating fuze is used to prevent the shell from being buried in the ground before bursting.

The total length of the gas shell fuzed with the Mark III point detonating fuze is 28.02 inches. The exterior surfaces are painted olive green.

#### COMMON STEEL SHELL, MARK IV.

(Plate VIIB.)

The high-explosive common steel shell, Mark IV, is designed with thin walls and carries a high charge. It has a total length, without adapter or fuze, of 24.29 inches, and an ogival head struck with a radius of 2.5 calibers. It is fitted with a copper rotating band forced into undercut seat 0.67 inch, from the base of the shell. The bottom

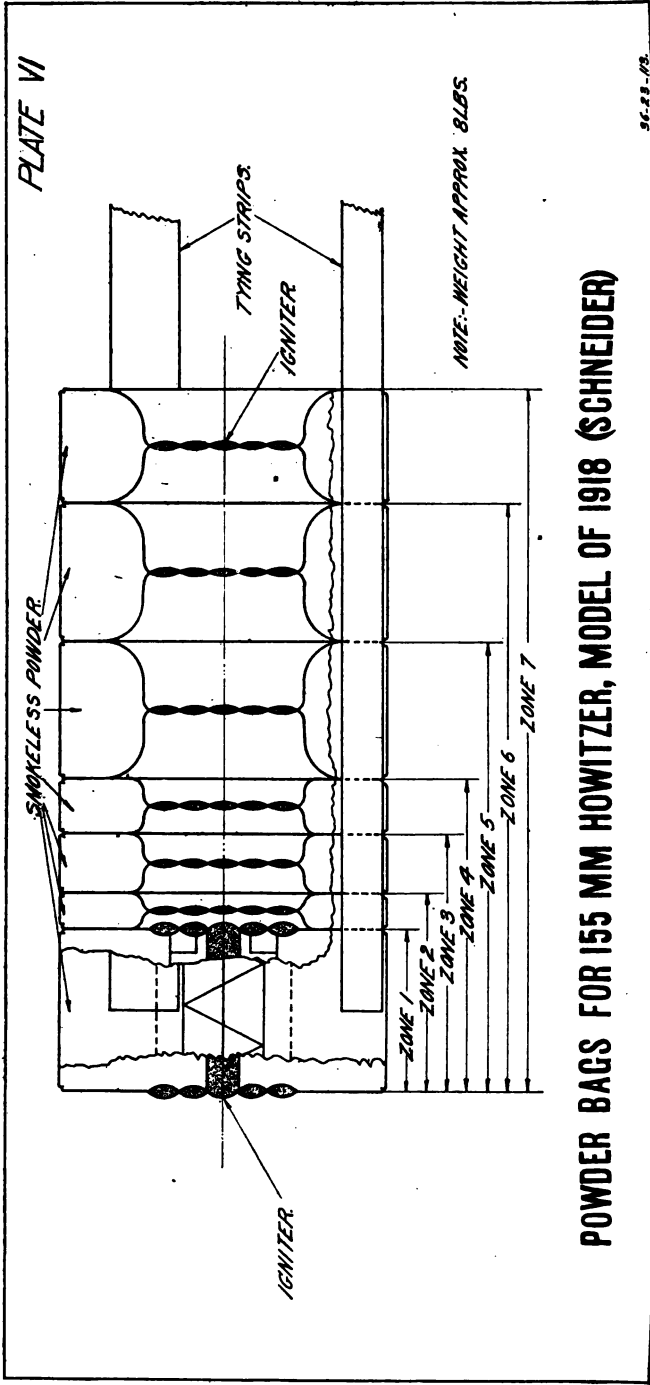

POWDER BAGS FOR 155 MM HOWITZER, MODEL OF 1918 (SCHNEIDER)

26 A

179395-20-3

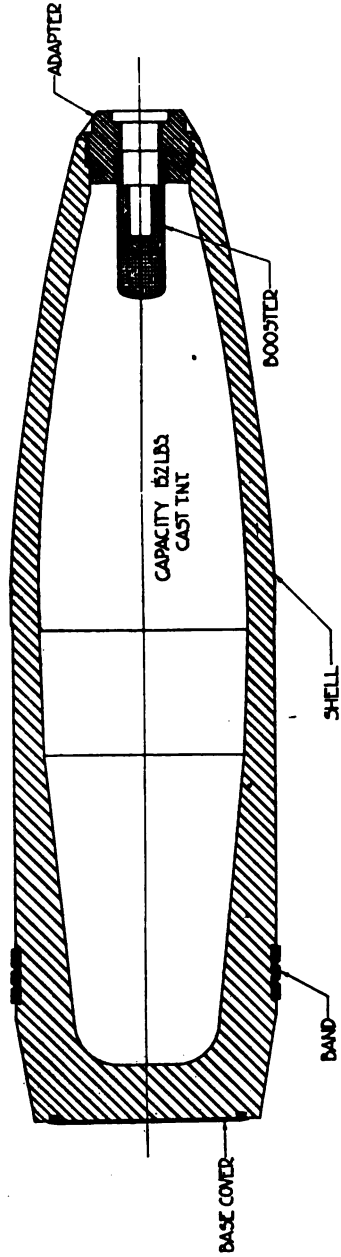

155 % COM. STEEL SHELL MADK-1

of the band seat is knurled, scored, or waved to prevent the band from slipping. The base of the shell is solid and is fitted with a base cover consisting of a lead disk and copper cover, which are calked into a circular undercut groove in the shell base with lead calking wire. The purpose of this cover is to prevent penetration of flame from the propelling charge through the base of the shell, and possibility of a premature burst in the bore.

The capacity of the shell is about 385 cubic inches fuzed, and it contains a bursting charge of about 20 pounds of high explosive when filled. Its weight, filled and fuzed, is approximately 94 (for howitzer) pounds (42.6 kg.).

#### SEMISTEEL SHELL, MARK XVII.

(Plate VIIB.)

The semisteel shell, Mark XVII, is used for smoke and gas, as well as for high explosive. Its length without adapter or fuze is 22.23 inches. It has an ogival head struck with a radius of 10.85 calibers. The nose of the shell is provided with tapered threads to receive the Mark V, V-A, V-B, or V-C adapter and booster. The shell has a taper base. No base cover is used, except when the charge is high explosive. The shell is fitted with a copper rotating band forced into an undercut seat 3.23 inches from the base of the shell. The bottom of the band seat is scored, waved, or knurled to prevent the band from slipping.

The capacity of the shell is about 171 cubic inches with the adapter and booster in place. The weight of the shell, filled and fuzed, is approximately 95 pounds (43 kg.).

#### SHRAPNEL.

The shrapnel, Plate VIII, is a base-charged shrapnel fitted with a combination time and percussion fuze. The case is of forged steel with solid base. The rotating band is forced into an annular groove cut into the case 0.6 inch from the base. The front, or mouth, of the case is closed by a steel head screwed in and tapped to take the service 45-second combination time and percussion fuze, Plate IX.

The bursting charge is composed of 1.35 pounds black shrapnel powder and is covered by a steel diaphragm. The diaphragm supports a central tube which extends forward to the fuze, and thus affords a conduit for the flame from the fuze to the bursting charge. At the rear end of the central tube a lug of dry gun cotton is fitted to assist the ignition of the bursting charge and to prevent the loose powder from getting into the tube. At the rear end of the head is a steel matrix cover with a hole in the center to allow the tube to pass through to the fuze.

The shrapnel filling between the steel diaphragm and the steel matrix cover is composed of approximately 849 lead balls of approximately 304 grains in weight. The interstices contain a smoke-

producing matrix of white naphthaline and melted resin. This matrix, in addition to serving as a smoke producer, prevents deformation of the lead balls. The head in front of the matrix cover is filled with resin up to the base of the fuze.

In action the case is not ruptured upon the explosion of the bursting charge, but the diaphragm, balls, head, and fuze are expelled from the case with increased velocity in much the same way as shot is expelled from a shotgun cartridge. The exterior surfaces are painted red.

#### FUZES.

*The 45-second combination fuze, Mark I (Plate IX).*—This is a point fuze for use with shrapnel. It combines time and percussion elements. It is set by turning a graduated ring carrying part of the time train, and may be reset as often as necessary. The parts are made up for the most part from brass and bronze.

The principal items of the 45-second combination fuze, Mark I, are as follows:

- (a) Fuze body.
- (b) Closing cap.
- (b1) Vents in closing cap.
- (b2) Safety wire.
- (c) Upper time-train ring.
- (c1) Washer for time-train ring, felt cloth.
- (d) Time-train ring, graduated.
- (d1) Washer for body, felt cloth.
- (d2) Rotating pin.
- (e) Concussion plunger.
- (e1) Concussion resistance ring.
- (f) Concussion firing pin.
- (g) Vent leading to upper time train.
- (h) Compressed powder pellet.
- (i) Upper time train, compressed powder.
- (j) Compressed-powder pellet, in vent leading to lower time train.
- (j1) Compressed-powder pellet in lower time-train vent.
- (k) Lower time train, compressed powder.
- (l) Brass disk, locked in place.
- (m) Compressed-powder pellet in vent "o."
- (o) Vent leading to magazine.
- (p) Powder magazine.
- (q) Percussion plunger.
- (r) Percussion primer.
- (s) Vents leading from percussion primer to magazine.
- (u) Bottom-closing screw.
- (v) Washer for closing screw, muslin.
- (w) Washer for closing screw, brass.

In the lower face of each ring a horseshoe-shaped annular groove is milled. Meal powder is compressed into these grooves under a pressure of 60,000 pounds per square inch, forming the time train. The time train in the two grooves totals a little over 12 inches in length.

PLATE VII A

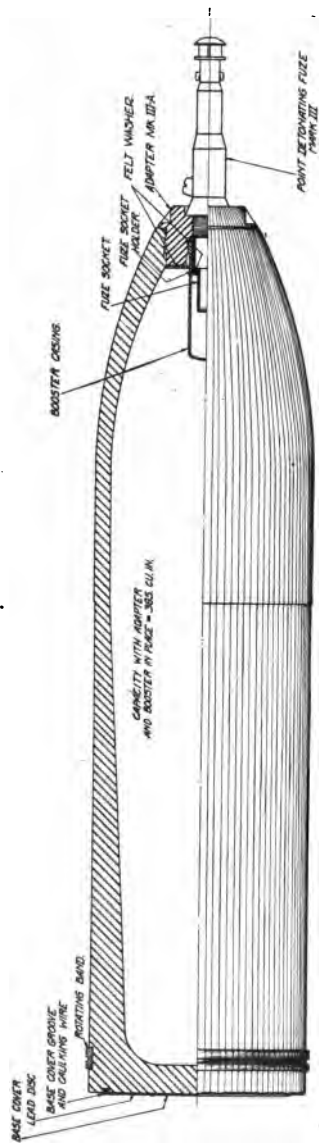

151 MM COMMON STEEL SHELL MK. IV

**PLATE VII B**

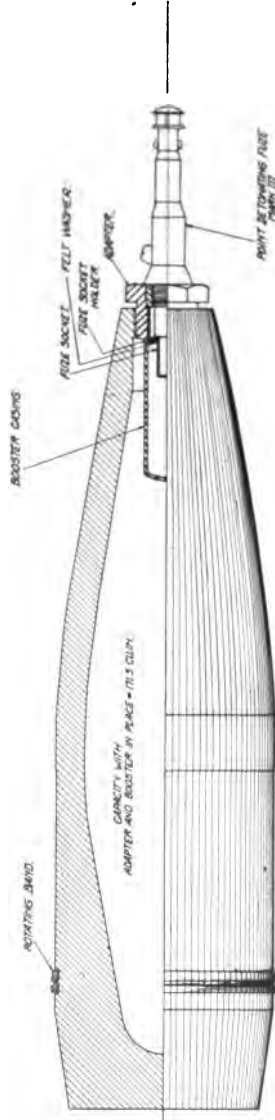

155 MM SEMI-STEEL SHELL MARK XIXII

The principal parts of the time element in this fuze are: The time or concussion plunger (*e*), the concussion resistance ring (*e1*), the firing pin (*f*), the compressed-powder pellet (*h*), the upper time train (*i*), the lower time train (*k*), and the compressed-powder pellet (*m*) in the vent (*o*) leading to the powder magazine (*p*).

The plunger (*e*) is cylindrical and contains the primer composition in a recess in its base. The concussion resistance ring (*e1*) prevents contact of the primer and firing pin until the projectile is fired. The acceleration of the projectile during discharge from the gun causes the plunger, through inertia, to spread the ring and bring the primer into contact with the firing pin. The flame from the primer passes out through the vent (*g*) which is drilled through the walls of the concussion plunger chamber and is exactly opposite a hole at one end of the upper time train. At the zero setting shown in the figure, the vents being all in register, the flame passes directly down vent (*j*), through a hole in the end of the time train (*k*), then through the vent (*o*) to the magazine (*p*), from which the flame is transmitted to the base charge of the shrapnel.

For any other setting (such as 12 seconds) the rotation of the graduated ring has separated the vents (*j*), (*g*), and (*o*), stopping direct access to the train (*k*) and forcing the flame to travel in a clockwise direction along the time train (*i*) until it reaches the new position of vent (*j*), then pass down to train (*k*) and back counterclockwise to vent (*o*), where it ignites the powder pellet (*m*) and explodes the powder magazine (*p*).

The lower time-train ring is graduated in a counterclockwise direction on its outer edge from 0 to 45½ seconds. For the 45½ second setting the vent (*j*) leading to the beginning of the lower time train is opposite the end of the upper time train and the end of the lower time train is opposite the vent (*o*) leading to the powder magazine. Thus the entire length of time train in both rings must be burned before the flame can reach the magazine (*p*).

A safety setting is obtained by utilizing the solid surfaces of the upper and lower time train rings left between the ends of the annular grooves. This position is indicated by a line on the outer edge of the graduated time-train ring, marked "S." When this line is brought opposite the datum line, the vent (*j*) is below the solid metal separating the ends of the upper time train in the upper ring, while the vent leading to the powder magazine (*p*) is covered by the solid metal separating the ends of the lower time train in the lower ring.

With the fuze set at safety the upper time train may burn entirely out, if the time plunger should be fired accidentally without the flame reaching the magazine (*p*). The solid metal of the lower ring, covering vent (*o*), gives additional safety in case of gas or flame leakage. The fuze should always be set at safety for transportation.

Washers (*c'*) and (*d'*) are glued to the upper face of the graduate time-train ring and to the upper face of the flange of the fuze body respectively. Both surfaces are scored as shown to make the washers adhere firmly. The washers act as gas checks and prevent premature action of the fuze.

The compressed pellet (*j'*) in the vent leading from the outside to the beginning of the lower time train is to release the pressure of the gases of the burning train. Escape of the gases from both time trains is through the annular spaces shown in the illustration and out the vents (*b'*) in the closing cap.

The percussion element of the fuze as shown in the plate consists of a centrifugal percussion plunger (*q*) and an ordinary percussion primer (*r*). The centrifugal plunger (*q*) is provided with a slot to receive the firing pin, which is mounted on a fulcrum and locked in the unarmed position by two pins forced against the countersunk hole in the firing pin by springs. These springs are designed to suit the velocity of rotation of the particular projectile in which the fuze is used. Centrifugal force due to the rotation of the projectile forces the pins outward against the pressure of the springs, releasing the firing pin, which is then rotated into its armed position by centrifugal force. Two restraining spring housings hold the entire plunger and its housing away from the primer during handling, transportation and flight. On impact, if the time mechanism has not already completely functioned, inertia carries the percussion plunger forward, firing the percussion primer. The vents (*s*) in the fuze body conduct the flame from the percussion primer to the magazine (*p*).

The bottom closing screw (*u*) closes the percussion plunger recess and keeps the powder in the magazine. The muslin washer (*v*) is shellacked and held by the brass washer (*w*). A projecting lip is crimped over the edge of the washer from the underedge of the bottom closing screw.

A hermetically sealed waterproof cover of sheet brass is provided for this fuze. The hood passes entirely over the fuze and is attached to the shrapnel head. It should be stripped off before attempting to set the fuze. The safety wire should also be removed before setting the fuze and replaced if the round is not fired. If the safety wire can not be replaced, the round should not be carried in ammunition chests or roughly handled and should be fired at the next firing.

*The 45-second combination fuze, model 1907 M.*—This is essentially the same as the Mark I fuze just described.

#### ADAPTERS AND BOOSTERS.

*Adapter and booster, Mark III-A (Plate IXA).*—The high explosive shells Mark I and Mark IV are fitted with the Mark III-A adapter and booster. The function of this booster is to give a suffi-

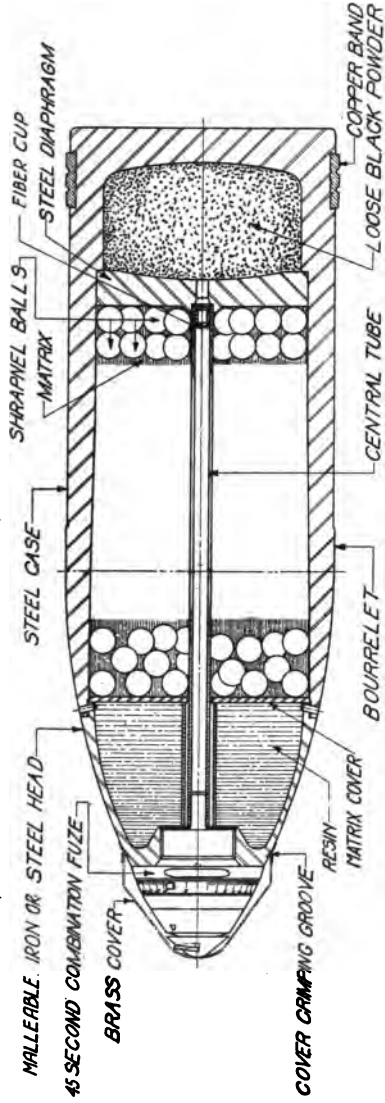

155mm SHRAPNEL - 95 LBS. MARK-I.

PLATE IX

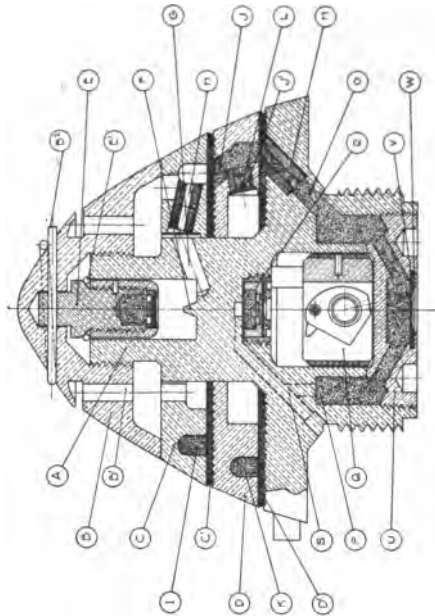
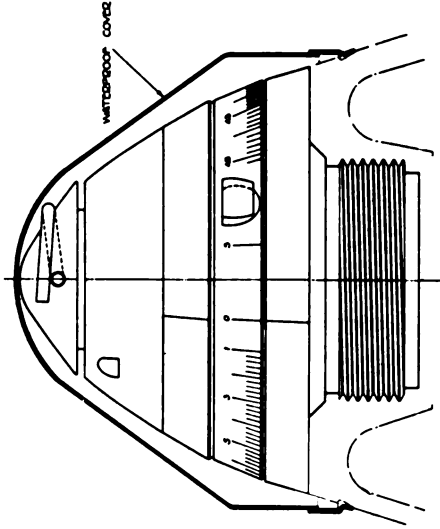

45-SECOND COMBINATION FUZE MARK I.

ciently violent detonation, when set off by the fuze, to completely detonate the bursting charge of the shell.

The adapter consists of a flanged steel collar, threaded on the outside to fit the nose of the shell. The interior of the collar is threaded at the rear to take the steel tube of the booster casing and is threaded at the front to take the threads of the fuze. A fuze socket holder into which is crimped a fuze socket is inserted into the front end of the booster tube. The booster is filled with high explosive loaded under pressure. As the shell are not fuzed until preparatory to firing, the adapter is stopped with an eyebolt lifting plug, which prevents the entrance of dirt or moisture into the fuze socket.

*Adapter and booster, Mark III-C.*—The semisteel shell, Mark XVII when loaded with high explosive, is fitted with the Mark III-C adapter and booster. This differs from the Mark III-A adapter and booster already described chiefly in that the threads on the outside of the adapter are tapered to fit the threads of the Mark XVII shell. No fuze socket holder is used, the fuze socket being set farther forward, with its flange clamped between the booster casing and adapter, thus permitting a somewhat larger charge to be used than in the Mark III-A adapter and booster.

*Adapters and boosters, Mark V, V-B, and V-C.*—The semisteel shell, Mark XVII, when filled with gas or smoke, is fitted with either the Mark V, V-B, or V-C adapter and booster. The function of each of these boosters is to burst the shell and scatter the contents.

The mark V adapter and booster is similar in all respects to the Mark VI adapter and booster, shown in Plate IXC and described in a subsequent paragraph, except that it is smaller.

The Mark V-B adapter and booster, shown in Plate IXC, consists of a drawn tube closed at the lower end with a steel bushing or adapter screwed into the upper end. The exterior of the upper end of the booster tube is provided with taper threads designed to make a gas-tight joint with the shell. A fuze socket and washer close the upper end of the booster casing and are held in place by the adapter. The high capacity of this adapter and booster permits it to be used with gases of low volatility.

The Mark V-C adapter and booster is exactly similar in construction to the Mark V-B, but is shorter and hence has a lower capacity. It is used interchangeably with the Mark V.

The fuze hole of each of these adapters and boosters is closed with a suitable plug, after loading, to prevent the entrance of dirt or moisture into the fuze socket.

*Adapter and boosters, Mark VI, VI-A, VI-B, and VI-C.*—The gas shell Mark II (howitzer) is fitted with the Mark VI, VI-A, VI-B, or VI-C adapter and booster. The function of each of these boosters is to burst the shell and scatter the contents.

In the Mark VI adapter and booster, shown in Plate IXC, the adapter consists of a steel bushing with taper threads on the exterior designed to make a gas-tight joint with the shell. The head is hexagonal and is fitted on the interior with a bushing threaded to receive the fuze. A fuze socket holder and fuze socket close the upper end of the booster and are held in place by the fuze bushing.

The booster casing consists of a drawn-steel tube welded to the lower end of the adapter. It is filled with high explosive loaded under pressure.

The Mark VI-B adapter and booster is similar in all respects to the Mark V-B, shown in Plate IXB and already described, except that it is larger. It has a high capacity and is designed for use with gases of low volatility.

The Mark VI-C adapter and booster is exactly similar to the Mark VI-B, but is shorter and hence has a lower capacity. It is used interchangeably with the Mark VI.

The fuze hole of each of these adapters and boosters is closed with a suitable plug, after loading, to prevent the entrance of dirt or moisture into the fuze socket.

#### POINT DETONATING FUZE, MARK IV.

The principal parts of the Mark IV fuze are shown assembled on Plate X, as follows:

A—Head plug.	J—Percussion plunger.
B—Body.	K—Safety casing.
BB—Detonator.	N—Retard spring.
C—Firing pin.	O—Retard carrier (delay or nondelay).
D—Arming casing.	Q—Detonator retainer.
E—Arming spring.	W—Relay cap.
F—Percussion primer.	X—Detonator casing.

In action the explosion of the propelling charge causes the arming casing to move backward against the arming spring, disengaging the points of the safety casing from the rear shoulders of the percussion plunger. The percussion plunger then moves forward into firing position, its front shoulders becoming engaged with the point of the arming casing, which prevents its return to the unarmed position. The retard spring prevents the plunger from moving too far forward, until on impact the tension of the retard spring is overcome and the firing pin explodes the percussion primer in the head of the plunger. Flame from this explosion is transmitted to the relay cap, the explosion of which explodes the detonator, which in turn detonates the booster charge, which detonates the bursting charge in the shell. This fuze may be fitted for either delay or nondelay action and is used on common steel shells.

PLATE IX A

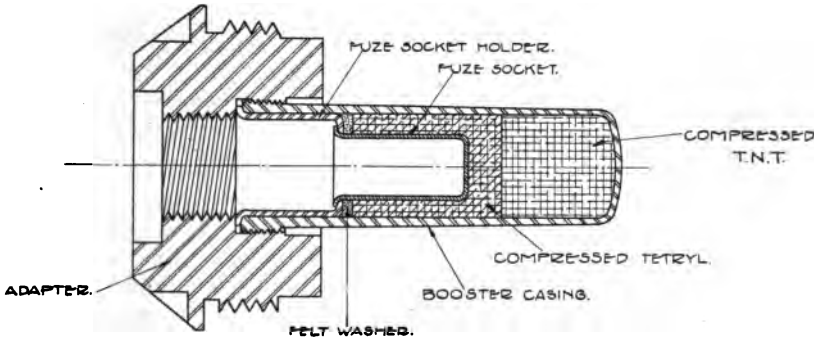

ADAPTER & BOOSTER MARK IIIA.

PLATE IX B



ADAPTER AND BOOSTER CASING MK IV B

PLATE IX C

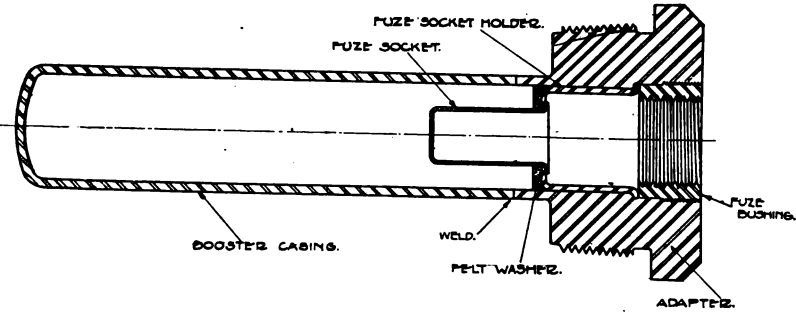

ADAPTER & BOOSTER MARK VI.

**Adapters and Boosters.**

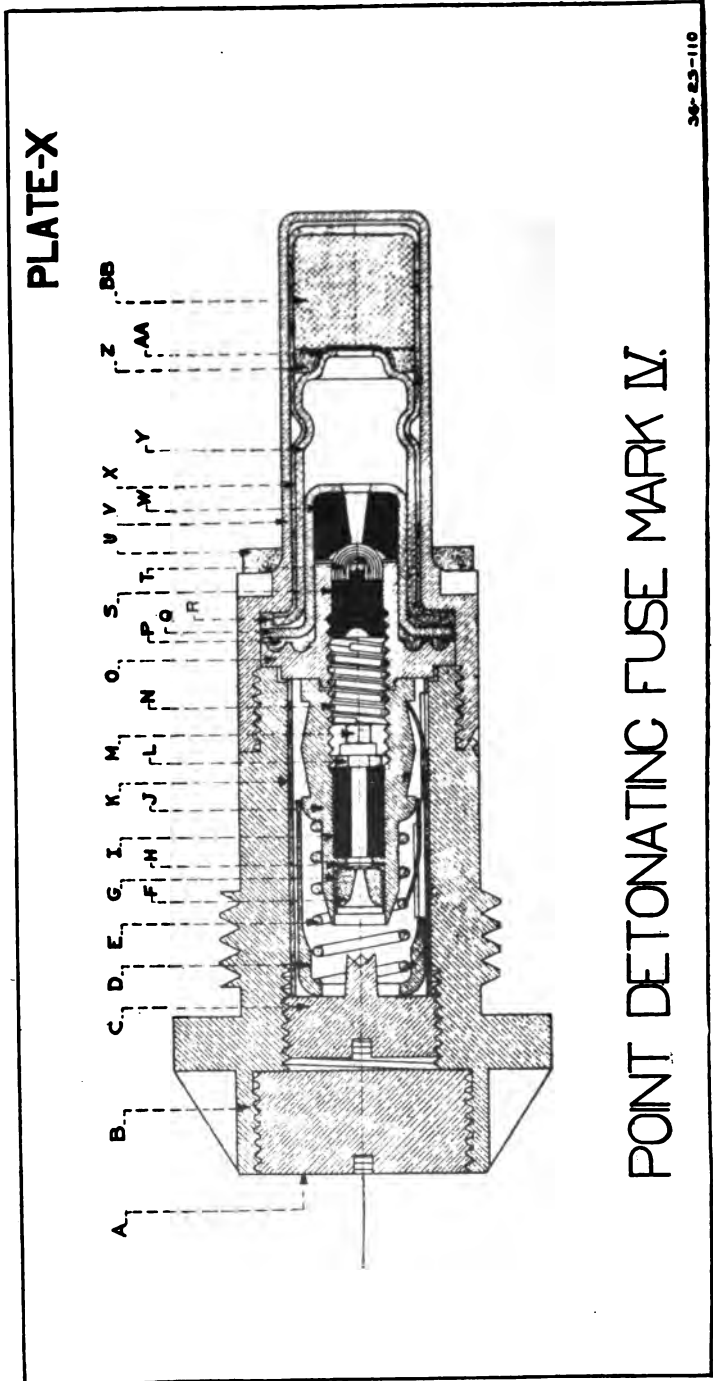

## POINT DETONATING FUZE, MARK III.

(Plate XI.)

The Mark III point detonating fuze is used with any of the high-explosive gas or smoke shells.

This fuze is designed to burst the shell before it can enter the ground. Its principal parts are: The body, cap, firing pin, firing-pin head, supporting washer, half rings, spiral, safety pin, percussion primer, upper detonator, shutter, and lower detonator.

The action of the fuze is as follows: The rotation of the projectile causes the spiral to unwind, due to centrifugal force acting on the weighted end. When the spiral flies off, the half rings accompany it. This arms the fuze by permitting the backward thrust of the firing pin on impact to fall directly on the safety pin. When this pin is bent the firing pin strikes the percussion primer. The explosion of the primer in turn explodes the upper detonator. If the shutter is open, the detonating wave from the upper detonator reaches the lower detonator through the channel, detonating it and the booster charge in the booster casing. These detonations follow in such rapid succession as to make the bursting of the shell practically simultaneous with the first impact of the firing-pin head.

The safety shutter is designed to prevent the communication of the detonating wave to the lower detonator in case of accidental firing of the primer and upper detonator. The spring holds the shutter closed during transportation. When the projectile is fired, inertia holds the shutter closed until the projectile leaves the muzzle and acceleration ceases. Centrifugal force then causes the plunger to fly outward, opening the channel.

## THE HAND FUZE SETTER.

The hand fuze setter, Plate XII, is a device for rapid and accurate setting of the 45-second combination fuze for various ranges and heights of burst. The principal parts of the fuze setter are as follows:

Case.	Corrector scale.
Worm knob.	Corrector scale support.
Worm case.	Guide plate.
Range ring.	Range ring carrier.
Index bar.	Worm adjusting screw.
Worm.	Range index.
Stop pin.	

The aluminum case of the setter has a serrated rim forming a handle for turning. The range ring is mounted on the range ring carrier, which is operated by the knob on the worm. The corrector scale is mounted on the corrector scale support and is operated by

the knob on the worm. The guide plate rests on the projectile. A slot is cut in the range ring carrier, which engages with the pin on the graduated time-train ring of the fuze. A stop pin is attached to the corrector scale support and engages with the stop pin of the fuze to limit the motion of the fuze setter.

In action the range index is set on the index bar to indicate the zone corresponding to the powder charge used. The knob of the range worm is turned until the required range on the range ring registers with the index. The corrector worm knob is then turned until the graduated line on the corrector scale which indicates the desired correction for the height of burst registers with the engraved arrow on the case.

In setting the fuze, the waterproof cap is removed, the safety wire withdrawn, and the hand fuze setter placed over the fuze and turned until the slot in the range ring carrier engages with the pin on the graduated time-train ring of the fuze. The guide plate and the range ring carrier will then bear firmly on the projectile. The fuze setter is then turned clockwise as indicated by the arrow on the top of the case, until the stop pin attached to the corrector scale support engages with the fixed stop pin on the fuze and further motion is prevented.

The pointer which is attached to the top of the corrector scale should register with the graduated line on the closing cap of the fuze to indicate when the stop pin of the fuze setter and the fixed stop pin of the fuze are in contact.

#### PACKING AMMUNITION FOR SHIPMENT.

The components of the rounds for the 155-mm. howitzer are prepared separately for shipment. Each box is stenciled in accordance with directions given in Ordnance Pamphlet 1868A, "Paints and Markings for Field Artillery Ammunition and Ammunition Boxes."

Common steel and gas shells are shipped unfuzed, with suitable plugs screwed into the fuze holes. The plugs are fitted with ring bolts to facilitate handling. A fiber or rope grommet is placed on each projectile to protect the copper rotating band. Punch marks on the outside of the projectile about one-half inch below the bourrelet indicate its weight.

The shrapnel is packed in a wooden box, fuzed with the 45-second combination fuze. The fuze is protected with a waterproof cover. The outside of the box is marked to indicate its contents. The primers are placed in moistureproof tin boxes, 20 to a box, and a number of these tin boxes are packed in a larger wooden box which is so marked on the outside as to indicate its contents and the lot number.

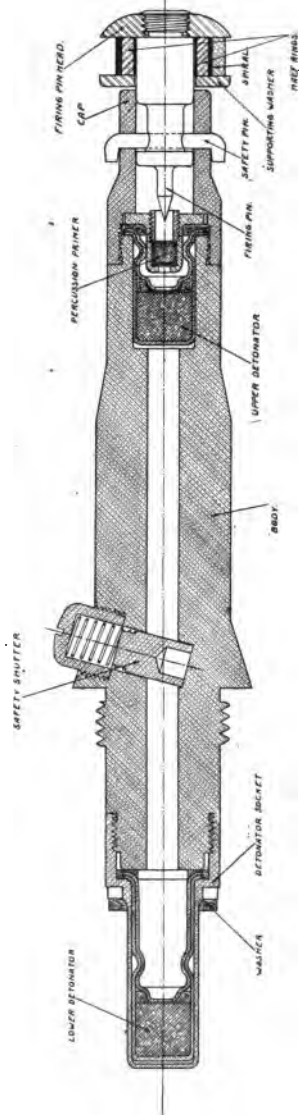

POINT DETONATING FUSE MARK III

PLATE-XII

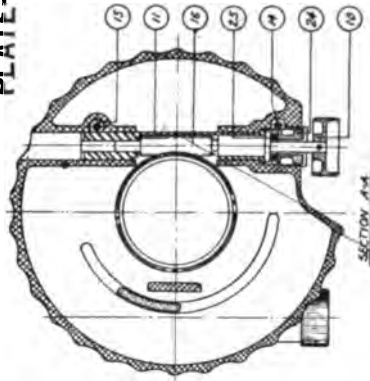
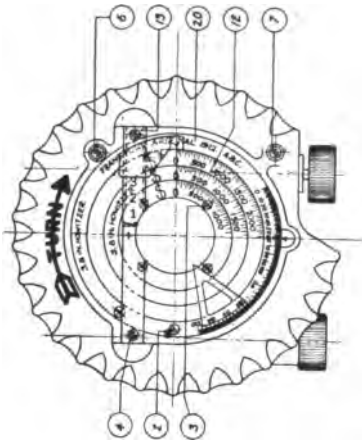

HAND FUZE SETTER  
MODEL OF 1913

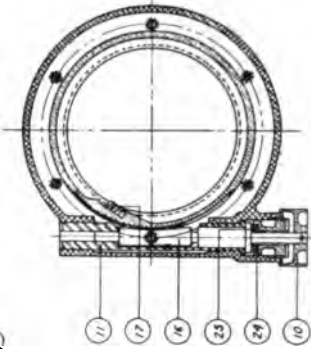
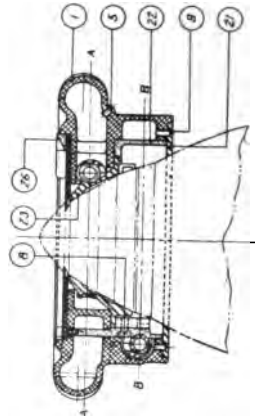

30-20-97

SECTION B-B

Point detonating fuzes, Mark III and IV, are packed in hermetically sealed tin boxes which are inclosed in wooden boxes, 50 Mark III and 100 Mark IV fuzes in a box. The boxes are so marked on the outside as to indicate their contents and the lot numbers of the same.

The combination fuzes are shipped assembled in the shrapnel.

The propelling charges of smokeless powder are packed for shipment in air-tight containers, each containing two charges, suitably marked on the outside to indicate the contents and lot number of the same.

### THE 155-MM. HOWITZER CARRIAGE, MODEL OF 1918 (SCHNEIDER).

#### WEIGHTS AND PRINCIPAL DIMENSIONS.

Weight of howitzer and carriage, completely equipped, in battery.....	3, 453. 6 kd.	=7, 600 lb.
Weight on ground under each wheel completely equipped, limbered.....	1, 363. 8 kg.	=3, 040 lb.
Weight on ground under each wheel, firing position, 0° elevation.....	1, 606. 3 kg.	=3, 534 lb.
Weight on ground under spade, firing position, 0° elevation.....	230. 9 kg.	= 532 lb.
Weight of carriage complete, without equipment.....	2, 145 kg.	=4, 729 lb.
Weight of carriage without sleigh.....	1, 270 kg.	=2, 794 lb.
Weight of recoiling parts.....	1, 590 kg.	=3, 498 lb.
Weight of each wheel.....	251. 6 kg.	= 553 lb.
Diameter of wheels.....	1, 350 mm.	= 53 in.
Width of track.....	1, 520 mm.	= 60 in.
Height of center line of howitzer.....	1, 443 mm.	= 57 in.
Height of center line of trunnions.....	1, 378 mm.	= 54 in.
Height of line of sight.....	1, 490. 5 mm.	= 59 in.
Normal length of recoil.....	1, 305 mm.	=51. 38 in.
Maximum elevation.....		42° .0'
Minimum elevation.....		0°
Maximum traverse (right).....		52. 5 mils.
Maximum traverse (left).....		52. 5 mils.

## NOMENCLATURE OF THE CARRIAGE.

(Property classification, Class IV, Division 3.)

The battery personnel is directed to use the following nomenclature, giving piece marks and drawing numbers, when referring to parts of the carriage in reports, correspondence, etc.

Number.	Name of part.	Piece mark.	Drawing.		
			Class.	Division.	Number.
1	Axle.....	152A	3	41	
	Including.....				
1	Asimuth scale.....	153F	3	41	
2	Asimuth scale screws.....	153E	3	41	
1	Traversing nut support.....	153B	3	41	
	Including.....				
1	Traversing nut collar.....	153A	3	41	
2	Traversing nut support liners.....	153D	3	41	
1	Traversing nut taper pin.....	153C	3	41	
1	Axle traveling lock mechanism, complete, consisting of—				
1	Axle traveling lock.....	99G	3	41	
1	Axle traveling lock bearing, including—				
2	Bolts (12 by 31 mm.).....	100C	3	41	
	Including.....				
2	Nuts, crown (12 mm.).....	100L	3	41	
2	Split pins (0.09 by 1.25 inches).....		30	2	
1	Axle traveling lock box.....	99A	3	41	
	Including.....				
1	Axle traveling lock bushing.....	100D	3	41	
1	Lock box cover.....	99F	3	41	
2	Bolts (14 by 37 mm.).....	100H	3	41	
	Including.....				
2	Nuts, crown (14 mm.).....	100K	3	41	
2	Screw downs.....	100N	3	41	
2	Split pins (0.125 by 1.25 inches).....		30	2	
1	Axle traveling lock lever.....	99K	3	41	
	Including.....				
1	Plunger.....	99L	3	41	
1	Plunger spring.....	100G	3	41	
1	Sleeve.....	99E	3	41	
1	Spindle.....	99H	3	41	
2	Axle traveling lock lever stops.....	100E	3	41	
	Including.....				
2	Nuts, crown (16 mm.).....	100M	3	41	
2	Split pins (0.125 by 1.5 inches).....		30	2	
1	Axle traveling lock shaft.....	100A	3	41	
	Including.....				
1	Lock shaft nut.....	100B	3	41	
1	Split pin (0.09 by 1.25 inches).....		30	2	
1	Axle traveling lock spring.....	100F	3	41	
1	Brake mechanism, complete, consisting of—				
1	Brake head (left).....	162E	3	41	
	Including.....				
1	Brake shoe.....	162C	3	41	
1	Spring cover.....	163H	3	41	
	Including.....				
1	Knob.....	71E	3	41	
1	Spring cover screw.....	102E	3	41	
1	Brake head (right).....	162D	3	41	
	Including.....				
1	Brake shoe.....	162C	3	41	
1	Spring cover.....	163H	3	41	
	Including.....				
1	Knob.....	71E	3	41	
1	Spring cover screw.....	102E	3	41	
1	Brake screw.....	163A	3	41	
	Including.....				
1	Brake handle.....	162A	3	41	
1	Brake screw stop.....	163B	3	41	
1	Brake screw supporting nut.....	163C	3	41	
1	Brake screw washer.....	163D	3	41	
1	Nut (16 mm.).....	163E	3	41	
1	Split pin (0.156 by 1.5 inches).....		30	2	
2	Split pin (0.203 by 2 inches).....		30	2	

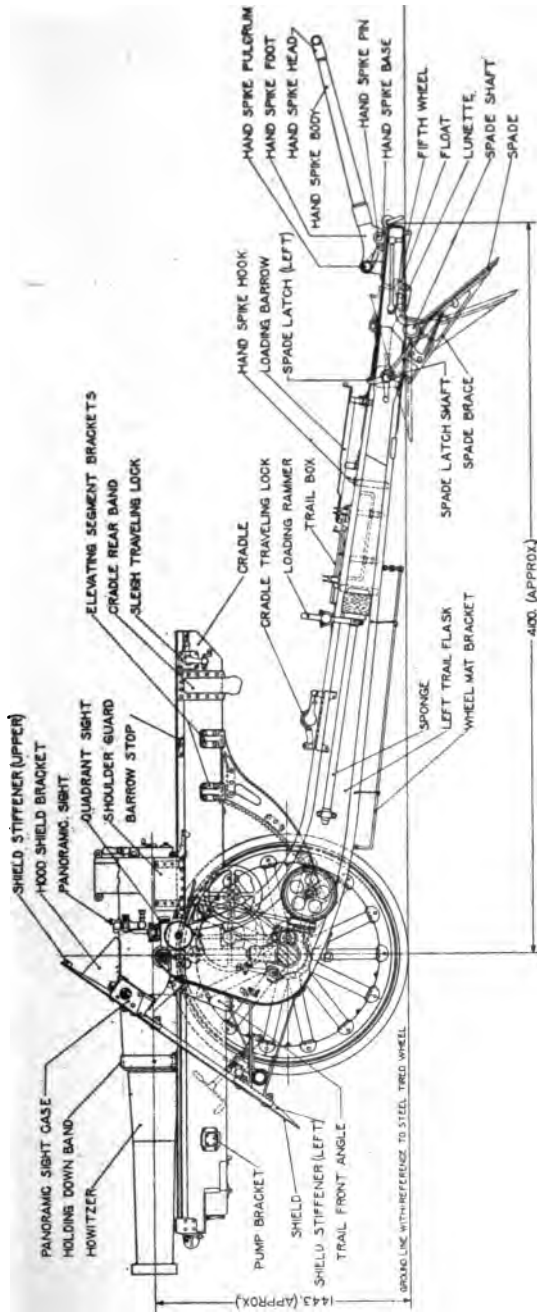

155 MM HOWITZER, MODEL OF 1918 (SCHNEIDER)  
LEFT SIDE ELEVATION, IN BATTERY

PLATE XIII A

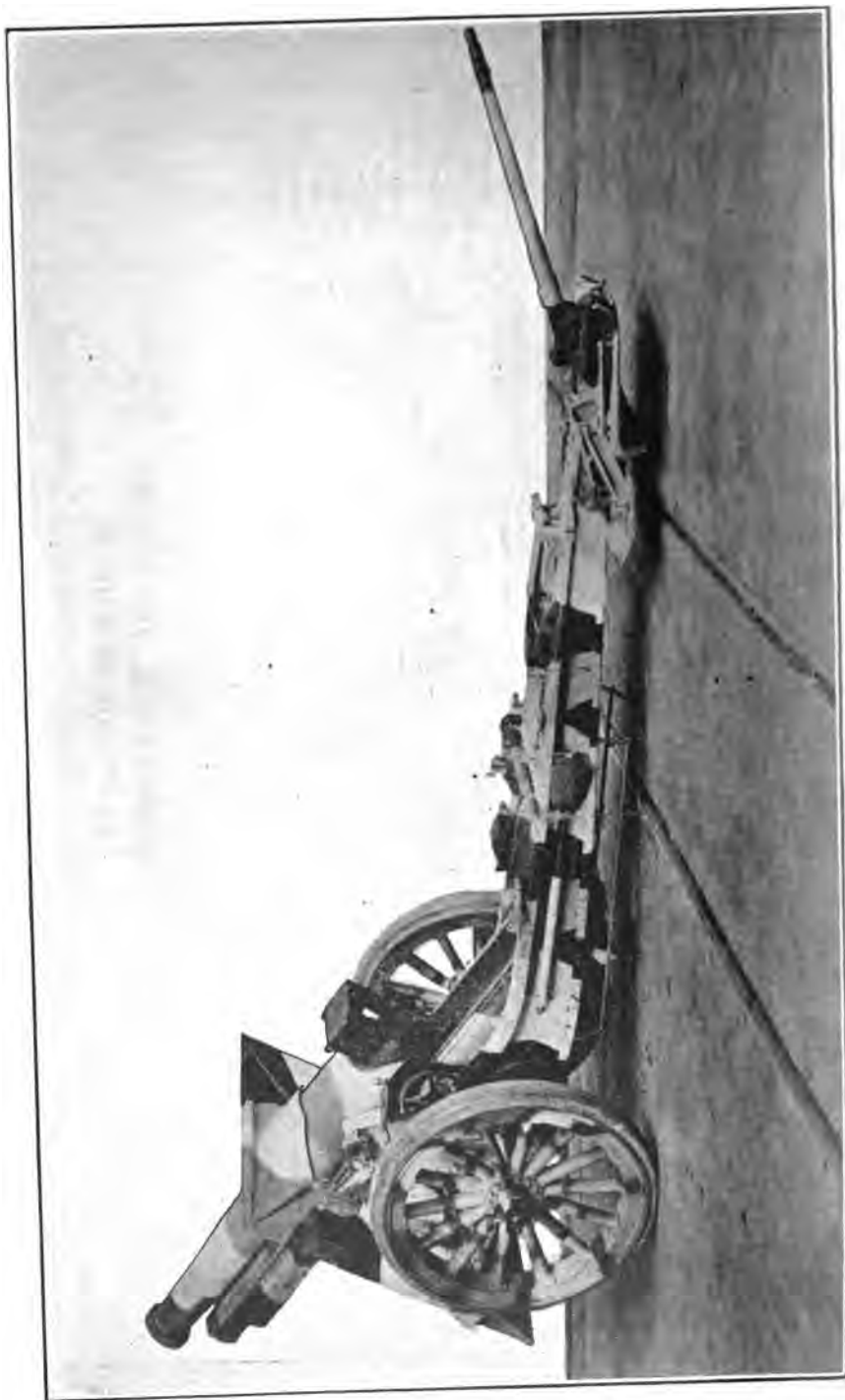

Number.	Name of part.	Piece mark.	Drawing.		
			Class.	Division.	Number.
	<b>Brake mechanism, complete, consisting of—Continued.</b>				
1	Brake screw bracket.....	164F.....	3	41	164
	Including—				
3	Bolts (14 by 35 mm.).....	163G.....	3	41	163
	Including—				
3	Nuts, crown (14 mm.).....	163N.....	3	41	163
3	Split pins (0.156 by 1.25 inches).....	.....	30	2	1
1	Brake screw supporting bushing.....	164E.....	3	41	164
1	Brake shaft.....	161A.....	3	41	161
1	Brake shaft arm (left).....	161C.....	3	41	161
	Including—				
1	Shaft arm nut.....	161E.....	3	41	161
1	Split pin (0.25 by 2.25 inches).....	.....	30	2	1
1	Brake shaft arm (right).....	161B.....	3	41	161
	Including—				
1	Shaft arm nut.....	161E.....	3	41	161
1	Split pin (0.25 by 2.25 inches).....	.....	30	2	1
1	Brake shaft bushing.....	164C.....	3	41	164
2	Brake shaft keys.....	164D.....	3	41	164
	Including—				
2	Split pins (0.203 by 2 inches).....	.....	30	2	1
1	Brake shaft lever.....	162B.....	3	41	162
	Including—				
1	Brake screw nut.....	163F.....	3	41	163
2	Brake shoe stops.....	163M.....	3	41	163
	<b>Cradle, complete, consisting of:</b>				
1	Adjusting stud.....	124E.....	3	41	124
	Including—				
1	Adjusting collar.....	124D.....	3	41	124
1	Adjusting nut.....	124C.....	3	41	124
1	Split pin (0.093 by 0.75 inch).....	.....	30	2	1
1	Barrow stop (left).....	126D.....	3	41	126
1	Barrow stop (right).....	126C.....	3	41	126
6	Brest head screws.....	115A.....	3	41	115
1	Cap hinge pin.....	118A.....	3	41	118
1	Cradle band (rear).....	122A.....	3	41	122
1	Cradle clip (left).....	119B.....	3	41	119
1	Cradle clip (right).....	119A.....	3	41	119
1	Cradle cover (front).....	124G.....	3	41	124
	Including—				
1	Fastening eye.....	125E.....	3	41	125
1	Cradle cover (front) hasp.....	125H.....	3	41	125
1	Hinge (cradle cover front).....	125B.....	3	41	125
1	Locking pin.....	125L.....	3	41	125
	Including—				
1	Nut (13 mm.).....	125F.....	3	41	125
2	Pin (3 by 18 mm., driven).....	.....	3	41	125
1	Locking pin bearings.....	125K.....	3	41	125
1	Locking pin lever.....	125G.....	3	41	125
1	Thong.....	118E.....	3	41	118
1	Cradle cover (bottom).....	124F.....	3	41	124
	Including—				
1	Fastening plate.....	125D.....	3	41	125
	Including—				
1	Fastening screw.....	125N.....	3	41	125
1	Pin (2.5 by 25 mm., riveted).....	.....	30	2	1
1	Split pin (0.09 by 1.5 inches).....	.....	3	41	125
1	Hinge (cradle cover bottom).....	125C.....	3	41	125
1	Cradle head.....	118B.....	3	41	118
1	Cradle head cap.....	118C.....	3	41	118
	Including—				
1	Cap latch pin.....	118D.....	3	41	118
	Including—				
1	Chain.....	JB5R.....	15	2KJ	5
2	Chain rings.....	JB5M.....	15	2KJ	5
1	Chain rivet.....	JB5L.....	15	2KJ	5
1	Thong.....	118E.....	3	41	118
1	Correction pressure plate.....	166D.....	3	41	166
1	Cradle plate.....	115D.....	3	41	115
1	Cradle transom.....	119A.....	3	41	119
1	Elevating segment bracket (front).....	121B.....	3	41	121
1	Elevating segment bracket (rear).....	121C.....	3	41	121
1	Elevating stop.....	107F.....	3	41	107
	Including—				
2	Elevating stop screws.....	107G.....	3	41	107
1	Fastening nut.....	125P.....	3	41	125
1	Firing mechanism bracket.....	128B.....	3	41	128
	Including—				
1	Handle return spring housing.....	129E.....	3	41	129
1	Housing screw.....	130F.....	3	41	130
1	Screw.....	128A.....	3	41	128

Number.	Name of part.	Piece mark.	Drawing.		
			Class.	Division.	Number.
	<b>Cradle, complete, consisting of—Continued.</b>				
1	Firing safety latch guide.....	130B.....	3	41	130
	Including—				
1	Hole cover.....	130A.....	3	41	130
1	Hinge pin.....	125M.....	3	41	125
2	Instruction plates.....	166G.....	3	41	166
2	Instruction plates.....	166K.....	3	41	166
1	Latch cover hinge.....	129C.....	3	41	129
	Including—				
1	Pin (5.9 by 82 mm., riveted).....				
1	Lock lever fulcrum.....	123E.....	3	41	123
1	Pump bracket.....	125A.....	3	41	125
1	Recoil indicator.....	124B.....	3	41	124
	Including—				
1	Pointer.....	124A.....	3	41	124
2	Safety shaft bearings, intermediate.....	130K.....	3	41	130
1	Safety shaft bearing, rear.....	130M.....	3	41	130
1	Shoulder guard.....	126A.....	3	41	126
	Including—				
2	Shoulder guard brackets.....	126B.....	3	41	126
1	Sleigh traveling lock bearing (left).....	127B.....	3	41	127
	Including—				
1	Cam screw.....	127F.....	3	41	127
	Including—				
1	Split pin (0.125 by 2 inches).....		30	2	1
1	Grease cup plug.....	73H.....	3	41	73
1	Grease cup spring.....	73L.....	3	41	73
1	Grease cup valve.....	73K.....	3	41	73
1	Sleigh traveling lock bearing (right).....	127A.....	3	41	127
	Including—				
1	Cam screw.....	127F.....	3	41	127
	Including—				
1	Split pin (0.125 by 2 inches).....		30	2	1
1	Grease cup plug.....	73H.....	3	41	73
1	Grease cup spring.....	73L.....	3	41	73
1	Grease cup valve.....	73K.....	3	41	73
1	Sleigh traveling lock catch (left).....	127C.....	3	41	127
1	Sleigh traveling lock catch (right).....	127D.....	3	41	127
1	Trunnion bracket.....	120A.....	3	41	120
	<b>Elevating mechanism, complete, consisting of:</b>				
1	Ball thrust bearing.....	103F.....	3	41	103
1	Dust cover.....	104K.....	3	41	104
1	Dust cover gasket.....	104L.....	3	41	104
1	Elevating hand wheel.....	104A.....	3	41	104
	Including—				
1	Direction plate.....	166C.....	3	41	166
1	Hand wheel knob.....	104B.....	3	41	104
1	Plunger.....	104G.....	3	41	104
1	Plunger spring.....	104H.....	3	41	104
1	Plunger spring washer.....	104F.....	3	41	104
1	Spindle.....	104C.....	3	41	104
1	Elevating hand wheel latch plate.....	104E.....	3	41	104
	Including—				
2	Set screws.....	104D.....	3	41	104
1	Elevating pinion shaft.....	102B.....	3	41	102
	Including—				
1	Pinion shaft nut.....	102A.....	3	41	102
1	Pinion shaft washer.....	102G.....	3	41	102
1	Split pin (0.25 by 2.5 inches).....		30	2	1
1	Elevating pinion shaft bracket.....	106E.....	3	41	106
	Including—				
1	Pinion shaft bushing.....	102H.....	3	41	102
2	Pinion shaft bracket bolts.....	106D.....	3	41	106
	Including—				
2	Nuts, crown (14 mm.).....	Q17GA.....	30	2	17
2	Split pins (0.125 by 1.25 inches).....		30	2	1
1	Spring cover.....	71F.....	3	41	71
	Including—				
1	Knob.....	71E.....	3	41	71
1	Spring cover screw.....	102E.....	3	41	102
	<b>Elevating segment unit, complete, consisting of—</b>				
1	Elevating segment (left).....	101B.....	3	41	102
1	Elevating segment (right).....	101A.....	3	41	102
1	Elevating segment transom (lower).....	108A.....	3	41	108
1	Elevating segment transom (middle).....	108B.....	3	41	108
1	Elevating segment transom (upper).....	108C.....	3	41	108

Number.	Name of part.	Piece mark.	Drawing.		
			Class.	Division.	Number.
	<b>Elevating mechanism, complete, consisting of—Contd.</b>				
	<b>Elevating segment unit, complete, consisting of—Con.</b>				
2	Transom bolts (14 by 50 mm.).....	108D.....	3	41	108
	Including—				
2	Nuts, crown (14 mm.).....	Q17GA.....	30	2	17
2	Plates.....	108F.....	3	41	108
2	Split pins (0.125 by 1.25 inches).....	.....	30	2	1
2	Washers.....	108E.....	3	41	108
2	Transom bolts (14 by 50 mm.).....	108G.....	3	41	108
	Including—				
2	Nuts, crown (14 mm.).....	Q17GA.....	30	2	17
2	Plates.....	108F.....	3	41	108
2	Split pins.....	.....	30	2	1
2	Washers.....	108E.....	3	41	108
1	Elevating worm.....	103B.....	3	41	103
1	Elevating worm shaft.....	103G.....	3	41	103
	Including—				
1	Handwheel retainer.....	93A.....	3	41	93
	Including—				
1	Split pin (0.125 by 1.25 inches).....	.....	30	2	1
1	Split pin (1.5 by 2 inches).....	.....	30	2	1
1	Split pin (1.5 by 1.5 inches).....	.....	30	2	1
1	Worm shaft nut.....	103E.....	3	41	103
1	Worm shaft washer.....	103D.....	3	41	103
1	Elevating worm shaft bracket.....	107A.....	3	41	107
	Including—				
1	Bushing.....	107E.....	3	41	107
1	Pin (3 by 10 mm., bronze, driven).....	.....	3	41	107
2	Screw dowels.....	107C.....	3	41	107
1	Spring cover.....	102C.....	3	41	102
	Including—				
1	Knob.....	71E.....	3	41	71
1	Spring cover screw.....	102E.....	3	41	102
4	Worm shaft bracket bolts.....	107D.....	3	41	107
	Including—				
4	Nuts, crown (12 mm.).....	Q17FA.....	30	2	17
4	Split pins (0.093 by 1.25 inches).....	.....	30	2	1
1	Elevating worm wheel.....	103A.....	3	41	103
1	Elevating worm wheel case.....	105F.....	3	41	105
	Including—				
1	Bushing (20 by 19.5 mm.).....	110D.....	3	41	110
1	Bushing (25.1 by 26.9 mm.).....	110C.....	3	41	110
1	Bushing (46 by 49 mm.).....	110B.....	3	41	110
1	Bushing (46 by 50 mm.).....	110A.....	3	41	110
6	Cover bolts.....	106B.....	3	41	106
	Including—				
6	Nuts, crown (10 by 8 mm. thick).....	106C.....	3	41	106
6	Split pins (0.093 by 1.25 inches).....	.....	30	2	1
6	Washers.....	106F.....	3	41	106
1	Elevating worm wheel case cover.....	106A.....	3	41	106
1	Spring cover.....	71F.....	3	41	71
	Including—				
1	Knob.....	71E.....	3	41	71
1	Spring cover screw.....	102E.....	3	41	102
6	Worm wheel case bolts.....	105D.....	3	41	105
	Including—				
6	Nuts, crown (14 mm.).....	Q17GA.....	30	2	17
6	Split pins (0.125 by 1.25 inches).....	.....	30	2	1
1	Worm wheel case bolt.....	105G.....	3	41	105
	Including—				
1	Nut, crown (14 mm.).....	Q17GA.....	30	2	17
1	Split pin (0.125 by 1.25 inches).....	.....	30	2	1
	<b>Firing mechanism, complete, consisting of—</b>				
1	Firing mechanism striker.....	130G.....	3	41	130
	Including—				
1	Firing handle.....	129L.....	3	41	129
1	Firing handle shaft.....	130C.....	3	41	130
	Including—				
1	Firing handle shaft nut.....	130D.....	3	41	130
1	Firing handle shaft piston.....	130L.....	3	41	130
1	Lanyard hook.....	130E.....	3	41	130
1	Split pin (0.125 by 1.25 inches).....	.....	30	2	1
1	Pin (4 by 32 mm., riveted).....	.....	3	41	130
1	Pin (3 by 24 mm.).....	.....	3	41	128
1	Washer (leather).....	130H.....	3	41	130
1	Firing safety latch.....	128K.....	3	41	128
1	Firing safety latch cover.....	129A.....	3	41	129
	Including—				
1	Split pin (0.062 by 0.75 inch).....	.....	30	2	1
1	Washer.....	129D.....	3	41	129
1	Firing safety shaft.....	129M.....	3	41	129

Number.	Name of part.	Piece mark.	Drawing.		
			Class.	Division.	Number.
	<b>Firing mechanism, complete, consisting of—Continued.</b>				
1	Firing safety shaft lever	128H	3	41	128
1	Handle return spring	129F	3	41	129
1	Lanyard pulley bracket	128E	3	41	128
	Including—				
1	Bolt (long)	129H	3	41	129
	Including—				
1	Split pin (0.125 by 1 inch)		30	2	1
1	Bolt (short)	129G	3	41	129
	Including—				
1	Split pin (0.125 by 1 inch)		30	2	1
2	Bolt locks	129K	3	41	129
1	Lanyard pulley (large)	128D	3	41	128
1	Lanyard pulley (small)	128C	3	41	128
2	Pegs	128F	3	41	128
3	Screws	128G	3	41	128
	<b>Handspike, complete, consisting of—</b>				
1	Cross bar	83C	3	41	83
2	Cross bar caps	83E	3	41	83
1	Cross bar filler	83D	3	41	83
1	Handspike body	85A	3	41	83
1	Handspike foot	83A	3	41	83
1	Handspike head	83F	3	41	83
1	Handspike fulcrum	84B	3	41	84
	Including—				
1	Fulcrum nut	84A	3	41	84
1	Handle spindle	84F	3	41	84
1	Pin (4 by 40 mm., driven)				
1	Plunger	84D	3	41	84
1	Sleeve	84G	3	41	84
1	Spring	84E	3	41	84
	<b>Locking mechanism, complete, consisting of—</b>				
1	Lock lever	123B	3	41	123
	Including—				
1	Lock lever handle	123G	3	41	123
1	Lock lever pin	123H	3	41	123
1	Split pin (0.125 by 1.5 inches)		30	2	1
1	Piston rod lock	123A	3	41	123
	Including—				
1	Safety catch	123C	3	41	123
1	Screw	123D	3	41	123
	<b>Panoramic sight case, complete, consisting of—</b>				
1	Bracket	CB12A	15	2KC	12
	Including—				
2	Bearing plates (lower)	CB12K	15	2KC	12
2	Bearing plates (upper)	CB12L	15	2KC	12
4	Bolts (0.375 by 5.482 inches)	CB11M	15	2KC	11
	Including—				
4	Nuts, crown (0.375 inch)	Q68A	30	2	6
4	Split pins (0.063 by 1 inch)		30	2	1
1	Chain	JB5C	15	2KJ	5
	Including—				
1	Bolt snap	JB5J	15	2KJ	5
2	Chain rings	JB5M	15	2KJ	5
1	Chain rivet	JB5L	15	2KJ	5
1	Padlock No. 840	JB5F	15	2KJ	5
8	Panoramic sight case springs	CB11D	15	2KC	11
4	Pipes	CB11L	15	2KC	11
4	Screws (0.5 by 0.812 inch, round head)	CB12B	15	2KC	12
	Including—				
4	Nuts, crown (0.5 inch)	Q6UA	30	2	6
4	Split pins (0.125 by 1.25 inches)		30	2	1
2	Spring supports	CB12C	15	2KC	12
1	Case body	CB12F	15	2KC	12
	Including—				
1	Case back	CB12G	15	2KC	12
2	Case hinges (lower half)	CB11F	15	2KC	11
2	Case supports	CB12H	15	2KC	12
2	Hinge pins	CB11K	15	2KC	11
1	Lid stop	CB12D	15	2KC	12
1	Wing nut	JB1Q	15	2KJ	1
1	Wing nut pin	CB11H	15	2KC	11
1	Wing nut reinforce	CB11J	15	2KC	11
1	Lid	CB12E	15	2KC	12
	Including—				
2	Case hinges (upper half)	CB11E	15	2KC	11
1	Hasp	CB11B	15	2KC	11
	Including—				
1	Hasp hinge	CB11A	15	2KC	11
1	Hinge pin	CB11K	15	2KC	11

Number.	Name of part.	Piece mark.	Drawing.		
			Class.	Division.	Number.
	Panoramic sight case, complete, consisting of—Continued.				
	Lid—Continued.				
1	Sight bracket.....	CB15A.....	15	2KC	15
	Including—				
1	Bracket spring, including.....	CB15C.....	15	2KC	15
1	Bracket spring lug.....	CB15D.....	15	2KC	15
1	Split pin (0.156 by 5 inches).....	.....	30	2	1
1	Wrench stud.....	CB15B.....	15	2KC	15
1	Shield, complete, consisting of—				
1	Hinge, outer (lower).....	160D.....	3	41	160
1	Hinge, outer (upper).....	160C.....	3	41	160
1	Hinge pin.....	160A.....	3	41	160
1	Hood.....	157G.....	3	41	157
1	Hood angle.....	157H.....	3	41	157
1	Latch spring.....	160K.....	3	41	160
2	Separators (A=3.96 mm.).....	157B.....	3	41	157
2	Separators (A=5.22 mm.).....	158C.....	3	41	158
2	Separators (B=9.03 mm.).....	158H.....	3	41	158
2	Separators (A=9.77 mm.).....	157C.....	3	41	157
2	Separators (B=14.88 mm.).....	158G.....	3	41	158
2	Separators (A=15.6 mm.).....	157D.....	3	41	157
2	Separators (B=20.72 mm.).....	158F.....	3	41	158
2	Separators (A=21.4 mm.).....	157E.....	3	41	157
2	Separators (A=22.57 mm.).....	158D.....	3	41	158
22	Separators (26 mm., long).....	158E.....	3	41	158
1	Shield (left).....	156B.....	3	41	156
1	Shield (right).....	156A.....	3	41	156
4	Shield bolts (B=33.5 mm.).....	159E.....	3	41	159
	Including—				
4	Nuts, crown (18 mm.).....	Q17KA.....	30	2	17
4	Screw dowels.....	159K.....	3	41	159
4	Split pins (0.156 by 1.5 inches).....	.....	30	2	1
4	Washers.....	159N.....	3	41	159
4	Shield bolts (B=38 mm.).....	159F.....	3	41	159
	Including—				
4	Nuts.....	Q17KA.....	30	2	17
4	Screw dowels.....	159K.....	3	41	159
4	Split pins (0.156 by 1.5 inches).....	.....	30	2	1
4	Washers.....	159N.....	3	41	159
1	Shield butt strap (lower).....	159C.....	3	41	159
1	Shield butt strap (upper).....	159D.....	3	41	159
2	Shield screw eyes.....	159P.....	3	41	159
	Including—				
2	Pins (5 by 8 mm., driven).....	.....			
2	Shield screw eye nuts.....	159Q.....	3	41	159
1	Shield stiffener (left).....	158B.....	3	41	158
1	Shield stiffener (right).....	158A.....	3	41	158
1	Shield stiffener (upper).....	157A.....	3	41	157
1	Sight port shutter.....	160B.....	3	41	160
	Including—				
1	Hinge (inner).....	160E.....	3	41	160
1	Knob.....	160F.....	3	41	160
1	Shutter latch.....	160G.....	3	41	160
1	Wing nut.....	160L.....	3	41	160
	Including—				
1	Round nut.....	160M.....	3	41	160
1	Split pin (0.062 by 0.75 inch).....	.....	3	41	1
1	Wing nut bearing.....	160H.....	30	2	160
1	Stiffener reinforce (lower left).....	159B.....	3	41	159
1	Stiffener reinforce (lower right).....	159A.....	3	41	159
2	Stiffener reinforce (upper).....	159G.....	3	41	159
1	Sleigh, complete, consisting of—				
1	Air tank head (left).....	141C.....	3	41	141
	Including—				
1	Air tank head key (lower).....	141B.....	3	41	141
1	Air tank head key (upper).....	141A.....	3	41	141
1	Gland locking screw.....	146K.....	3	41	146
1	Air tank head (right).....	141E.....	3	41	141
1	Air tank head follower (left).....	140B.....	3	41	140
	Including—				
1	Follower screw.....	140C.....	3	41	140
1	Air tank head follower (right).....	140A.....	3	41	140
	Including—				
1	Follower screw.....	140C.....	3	41	140
2	Air tank head glands.....	140D.....	3	41	140
1	Buffer rod.....	138A.....	3	41	138
	Including—				
1	Buffer guide.....	138C.....	3	41	138
1	Buffer rod nut.....	138D.....	3	41	138
1	Counter-recoil valve.....	138B.....	3	41	138
1	Pin (4 by 24 mm., driven).....	.....			

Number.	Name of part.	Piece mark.
	<b>Sleigh, complete, consisting of—Continued.</b>	
1	Counter-recoil cylinder head .....	134H
1	Counter-recoil rod .....	136G
	Including—	
1	Counter-recoil piston liner .....	137A
	Including—	
1	Screw (3 by 6 mm., headless) .....	137B
1	Counter-recoil piston lubricator .....	144H
1	Counter-recoil piston lubricator gland .....	137E
	Including—	
1	Screw (4 by 5 mm., headless) .....	137F
1	Counter-recoil piston nut .....	137D
	Including—	
1	Split pin (0.125 by 1.5 inches) .....	
1	Counter-recoil piston nut liner .....	137C
1	Counter-recoil piston packing spring .....	137I
1	Counter-recoil piston rubber follower .....	137K
1	Counter-recoil piston rubber pad .....	143I
1	Counter-recoil piston spring case (inner) .....	137J
1	Counter-recoil piston spring case (outer) .....	137G
1	Counter-recoil rod extension .....	136
1	Counter-recoil rod nut .....	136
	Including—	
1	Pin (5 by 50 mm.) .....	136
1	Gasket No. 3 .....	11
1	Gasket No. 4 .....	11
1	Lock washer .....	1
	Including—	
1	Lock washer screw .....	
1	Obturator (inner) .....	
1	Obturator (outer) .....	
1	Counter-recoil stuffing box .....	
	Including—	
1	Counter-recoil rod gasket follower .....	
1	Counter-recoil rod lubricator .....	
1	Counter-recoil rod lubricator gland .....	
1	Counter-recoil rod packing seat .....	
1	Counter-recoil rod packing spring .....	
1	Counter-recoil rod packing spring compressor .....	
1	Counter-recoil rod rubber follower .....	
1	Counter-recoil rod rubber pad .....	
1	Counter-recoil rod spring case (inner) .....	
	Including—	
1	Screw .....	
1	Counter-recoil rod spring case (outer) .....	
1	Gasket No. 1 .....	
1	Gasket No. 2 .....	
1	Obturator (inner) .....	
1	Obturator (outer) .....	
2	Counter-recoil stops .....	
1	Counter-recoil stop plate .....	
1	Cylinder head lock .....	
	Including—	
1	Cylinder head lock screw .....	41
1	Filling valve body .....	41
	Including—	
1	Filling needle valve .....	41
1	Filling needle valve cap .....	41
1	Filling needle valve follower .....	41
1	Filling needle valve gland .....	41
1	Filling valve body extension .....	41
1	Filling valve cap .....	41
1	Filling valve follower .....	41
	Including—	
1	Screw (6 by 15 mm., headless) .....	2KJ
1	Gasket No. 11 .....	41
1	Gasket No. 12 .....	41
1	Screw (6 by 8 mm., countersunk head) .....	2KJ
1	Front band clip (left) .....	41
	Including—	
1	Screw (10 by 17 mm., countersunk head) .....	41
2	Screws (14 by 17 mm., countersunk head) .....	41
3	Screws (14 by 19 mm., countersunk head) .....	41
1	Front band clip (right) .....	41
	Including—	
1	Screw (10 by 17 mm., countersunk head) .....	41
2	Screws (14 by 17 mm., countersunk head) .....	41
3	Screws (14 by 19 mm., countersunk head) .....	41

Number.	Name of part.	Piece mark.	Drawing.		
			Class.	Division.	Number.
	Sleigh, complete, consisting of—Continued				
2	Front band keys.....	149A.....	3	41	149
	Including—				
2	Front band key washers.....	149B.....	3	41	149
2	Nuts, crown (12 mm.).....	149C.....	3	41	149
2	Split pins (0.125 by 1.25 inches).....	.....	30	2	1
1	Gage cock body.....	146A.....	3	41	146
	Including—				
1	Gage cock body diaphragm.....	146C.....	3	41	146
1	Gage cock body head.....	146G.....	3	41	146
1	Gage cock body nut.....	147D.....	3	41	147
	Including—				
1	Screw (5 by 7.5 mm., headless).....	147E.....	3	41	147
1	Gage cock body plug, front.....	146D.....	3	41	146
	Including—				
1	Plug nut.....	146E.....	3	41	146
1	Split pin (0.093 by 1 inch).....	.....	30	2	1
1	Gage cock body plug, rear.....	146H.....	3	41	146
1	Gage cock body plug gland.....	146F.....	3	41	146
1	Gage cock pointer.....	147F.....	3	41	147
	Including—				
2	Screws (5 by 7.5 mm., headless).....	147E.....	3	41	147
1	Gage cock valve.....	147B.....	3	41	147
1	Gage cock valve disk.....	142F.....	3	41	142
	Including—				
1	Screws (4 by 10.5 mm.).....	147H.....	3	41	147
1	Gage cock valve gland.....	147G.....	3	41	147
1	Gage cock valve spring.....	147C.....	3	41	147
1	Gage cock valve stem.....	147A.....	3	41	147
1	Gasket No. 8.....	142C.....	3	41	142
1	Gasket No. 9.....	142D.....	3	41	142
1	Gasket No. 10.....	142E.....	3	41	142
1	Gasket No. 8 gland.....	146B.....	3	41	146
2	Gasket No. 7.....	143L.....	3	41	143
1	Gasket (96 by 100 by 2 mm., copper).....	144L.....	3	41	144
2	Gaskets (114 by 118 by 2 mm., copper).....	144M.....	3	41	144
4	Grease cups.....	145A.....	3	41	145
	Including—				
4	Grease cup plugs.....	73H.....	3	41	73
4	Grease cup springs.....	73L.....	3	41	73
4	Grease cup valves.....	73K.....	3	41	73
4	Screws (4 by 7 mm.).....	145B.....	3	41	145
1	Recoil cylinder head.....	134E.....	3	41	134
	Including—				
1	Filling plug.....	134D.....	3	41	134
1	Filling plug gasket.....	144N.....	3	41	144
1	Pin (6 by 96 mm.).....	134F.....	3	41	134
1	Recoil piston rod.....	135A.....	3	41	135
	Including—				
1	Recoil piston liner.....	135B.....	3	41	135
	Including—				
2	Piston liner screws.....	135F.....	3	41	135
1	Recoil piston rod nut.....	136D.....	3	41	136
	Including—				
1	Pin (6 by 81 mm.).....	136E.....	3	41	136
1	Recoil piston rod plug.....	135C.....	3	41	135
1	Throttling ring.....	135E.....	3	41	135
	Including—				
1	Throttling ring screw.....	135D.....	3	41	135
1	Recoil stuffing box.....	134B.....	3	41	134
	Including—				
1	Gasket No. 5.....	143E.....	3	41	143
1	Gasket No. 6.....	143F.....	3	41	143
1	Obturator (inner).....	144D.....	3	41	144
1	Obturator (outer).....	144C.....	3	41	144
1	Oil hole plug.....	134A.....	3	41	134
1	Piston rod gasket follower.....	139A.....	3	41	139
	Including—				
1	Screw (4 by 6 mm., headless).....	134C.....	3	41	134
1	Piston rod lubricator.....	144G.....	3	41	144
1	Piston rod lubricator gland.....	139H.....	3	41	139
1	Piston rod packing seat.....	139B.....	3	41	139
1	Piston rod packing spring.....	134K.....	3	41	134
1	Piston rod packing spring compressor.....	139G.....	3	41	139
1	Piston rod rubber follower.....	139C.....	3	41	139
1	Piston rod rubber pad.....	143D.....	3	41	143

Number.	Name of part.	Piece mark.	Drawing.		
			Class.	Division.	Number.
	<b>Sleigh, complete, consisting of—Continued.</b>				
	<b>Recoil stuffing box—Continued.</b>				
1	Piston rod spring case (inner).....	139F.....	3	41	139
	Including—				
1	Screw (4 by 3.5 mm.).....	139E.....	3	41	139
1	Piston rod spring case (outer).....	139D.....	3	41	139
1	Screw (4 by 6 mm., headless).....	134C.....	3	41	134
1	Serial number plate.....	166H.....	3	41	166
	Including—				
4	Screws (4 by 6 mm., countersunk head).....	136F.....	3	41	136
1	Sleigh.....	131A.....	3	41	131
	Including—				
4	Front slide screws.....	132A.....	3	41	132
22	Rear slide screws.....	132D.....	3	41	132
1	Sleigh slide (left).....	132C.....	3	41	132
1	Sleigh slide (right).....	132B.....	3	41	132
1	Yoke.....	141D.....	3	41	141
1	Sleigh travelling lock (left).....	127G.....	3	41	127
	Including—				
1	Plunger.....	127L.....	3	41	127
1	Plunger spring.....	127M.....	3	41	127
1	Sleeve.....	127E.....	3	41	127
1	Spindle.....	127K.....	3	41	127
1	Sleigh travelling lock (right).....	127H.....	3	41	127
	Including—				
1	Plunger.....	127L.....	3	41	127
1	Plunger spring.....	127M.....	3	41	127
1	Sleeve.....	127E.....	3	41	127
1	Spindle.....	127K.....	3	41	127
1	Spade, complete, consisting of—				
1	Spade brace (left).....	77B.....	3	41	77
1	Spade brace (right).....	77A.....	3	41	77
1	Spade brace, diagonal (left).....	78B.....	3	41	78
1	Spade brace, diagonal (right).....	78A.....	3	41	78
1	Spade plate.....	76B.....	3	41	76
1	Spade plate reinforce.....	76A.....	3	41	76
2	Spade traveling hooks.....	76C.....	3	41	76
4	Screws (16 by 38 mm.).....	76D.....	3	41	76
1	Spade latch, complete, consisting of—				
1	Spade latch (left).....	80C.....	3	41	80
	Including—				
1	Latch handle.....	80D.....	3	41	80
1	Spade latch (right).....	80E.....	3	41	80
1	Spade latch shaft.....	80B.....	3	41	80
	Including—				
2	Pins (6 by 42 mm., driven).....				
2	Spade latch shaft nuts.....	80A.....	3	41	80
1	Spade shaft.....	79A.....	3	41	79
	Including—				
1	Pin (8 by 70 mm., driven).....				
1	Screw dowel.....	79E.....	3	41	79
1	Spade shaft nut.....	79B.....	3	41	79
1	Trail, complete, consisting of—				
1	Axle housing.....	86A.....	3	41	86
1	Axle housing boss.....	88G.....	3	41	88
1	Axle housing bushing (left).....	97H.....	3	41	97
1	Axle housing bushing (right).....	97G.....	3	41	97
1	Axle housing collar (left).....	88E.....	3	41	88
1	Axle housing collar (right).....	88F.....	3	41	88
1	Axle traveling lock catch (left).....	99C.....	3	41	99
1	Axle traveling lock catch (right).....	99B.....	3	41	99
1	Barrow clip.....	65E.....	3	41	65
2	Barrow fastenings (left).....	66G.....	3	41	66
	Including—				
2	Chains.....	JB5C.....	15	2KJ	5
	Including—				
2	Barrow fastening pins.....	66F.....	3	41	66
4	Chain rings.....	JB5M.....	15	2KJ	5
2	Chain eyes.....	66C.....	3	41	66
1	Barrow fastening (right front).....	66B.....	3	41	66
1	Barrow fastening (right rear).....	66A.....	3	41	66
1	Barrow support (left).....	65C.....	3	41	65
1	Barrow support (right).....	65D.....	3	41	65
1	Bottom plate reinforce.....	58D.....	3	41	58
1	Brake shaft bearing (left).....	164B.....	3	41	164
	Including—				
1	Spring cover.....	163H.....	3	41	163
	Including—				
1	Knob.....	71E.....	3	41	71
1	Spring cover screw.....	102E.....	3	41	102

Number.	Name of part.	Piece mark.	Drawing.		
			Class.	Division.	Number.
	Trail complete, consisting of—Continued.				
1	Brake shaft bearing (right).....	164A.....	3	41	164
	Including—				
1	Spring cover.....	163H.....	3	41	163
	Including—				
1	Knob.....	71E.....	3	41	71
1	Spring cover screw.....	102E.....	3	41	102
1	Brake shaft bearing support (lower left).....	155F.....	3	41	155
1	Brake shaft bearing support (lower right).....	155E.....	3	41	155
1	Brake shaft bearing support (upper left).....	155D.....	3	41	155
1	Brake shaft bearing support (upper right).....	155C.....	3	41	155
1	Chain (trail box).....	JB5C.....	15	2KJ	5
	Including—				
1	Bolt snap.....	JB5J.....	15	2KJ	5
2	Chain rings.....	JB5M.....	15	2KJ	5
1	Chain rivet.....	JB5L.....	15	2KJ	5
1	Padlock No. 840.....	JB5F.....	15	2KJ	5
2	Chains (trunnion caps).....	JB5U.....	15	2KJ	5
	Including—				
2	Chain eyes.....	73C.....	3	41	73
4	Chain rings.....	JB5M.....	15	2KJ	5
2	Spring cotters.....	73D.....	3	41	73
4	Chains (wheel mat bracket).....	JB5D.....	15	2KJ	5
	Including—				
4	Bolt snaps.....	JB5J.....	15	2KJ	5
12	Chain rings.....	JB5M.....	15	2KJ	5
4	Chain rivets.....	JB5L.....	15	2KJ	5
2	Cover hinges (female).....	64D.....	3	41	64
1	Depression stop.....	56B.....	3	41	56
	Including—				
2	Depression stop bolts.....	56C.....	3	41	56
	Including—				
2	Nuts, crown (14 mm.).....	56D.....	3	41	56
2	Split pins (1.5 by 1.25 inches).....		30	2	1
1	Draft hook (left).....	65A.....	3	41	65
1	Draft hook (right).....	65B.....	3	41	65
1	Elevating segment thrust bracket (left), consisting of—				
1	Elevating segment thrust bracket (lower).....	109B.....	3	41	109
1	Elevating segment thrust bracket (upper).....	109A.....	3	41	109
1	Thrust bracket plate (left).....	109F.....	3	41	109
	Including—				
2	Screws (10 by 24 mm., countersunk head).....	109C.....	3	41	109
	Including—				
2	Nuts, crown (10 mm.).....	Q17EA.....	30	2	17
2	Split pins (0.093 by 1 inch).....		30	2	1
1	Screw (10 by 26 mm., countersunk head).....	109D.....	3	41	109
	Including—				
1	Nut, crown (10 mm.).....	Q17EA.....	30	2	17
1	Split pin (0.093 by 1 inch).....		30	2	1
2	Thrust bracket screws.....	109G.....	3	41	109
1	Elevating segment thrust bracket (right), consisting of—				
1	Elevating segment thrust bracket (lower).....	109K.....	3	41	109
1	Elevating segment thrust bracket (upper).....	109H.....	3	41	109
1	Thrust bracket plate (right).....	109E.....	3	41	109
	Including—				
2	Screws (10 by 24 mm., countersunk head).....	109C.....	3	41	109
	Including—				
2	Nuts, crown (10 mm.).....	Q17EA.....	30	2	17
2	Split pins (0.093 by 1 inch).....		30	2	1
1	Screw (10 by 26 mm., countersunk head).....	109D.....	3	41	109
	Including—				
1	Nut, crown (10 mm.).....	Q17EA.....	30	2	17
1	Split pin (0.093 by 1 inch).....		30	2	1
1	Thrust bracket screw.....	109G.....	3	41	109
1	Fifth wheel.....	81A.....	3	41	81
1	Filler plate (elevating worm shaft bracket).....	107B.....	3	41	107
1	Filler plate (hand spike base).....	82A.....	3	41	82
1	Filler plate (left) traversing gear case.....	92D.....	3	41	92
1	Filler plate (right) traversing gear case.....	91D.....	3	41	91
1	Fixed spade.....	74D.....	3	41	74
	Including—				
4	Grease cups.....	74A.....	3	41	74
	Including—				
4	Dowels.....	74B.....	3	41	74
4	Grease cup plugs.....	73H.....	3	41	73
4	Grease cup screws.....	74C.....	3	41	73
4	Grease cup springs.....	73L.....	3	41	73
4	Grease cup valves.....	73K.....	3	41	73
1	Float.....	75A.....	3	41	75
1	Front transom.....	55A.....	3	41	55
2	Gasket rings.....	98B.....	3	41	98
	Including—				
2	Gaskets.....	98D.....	3	41	98

Num-ber.	Name of part.	Piece mark.	Drawing.		
			Class.	Divi-sion.	Num-ber.
	Trail, complete, consisting of—Continued.				
1	Hand spike base.....	83C.....	3	41	82
	Including—				
1	Hand spike pin.....	84C.....	3	41	84
2	Screws (12 by 19 mm.).....	82D.....	3	41	82
2	Split pins (.625 by 3 inches).....		30	2	1
1	Instruction plate.....	166G.....	3	41	166
1	Instruction plate.....	166K.....	3	41	166
1	Latch shaft spring.....	79C.....	3	41	79
	Including—				
1	Dowel (12 mm., riveted).....	79F.....	3	41	79
1	Latch spring bolt.....	79D.....	3	41	79
	Including—				
1	Nut, crown (10 mm.).....	Q17EA.....	30	2	17
1	Split pin (0.093 by 1 inch).....		30	2	1
1	Loading rammer fastening (left).....	67A.....	3	41	67
1	Loading rammer fastening (right).....	67B.....	3	41	67
1	Lock bearing (left).....	71B.....	3	41	71
	Including—				
1	Cam screw.....	71C.....	3	41	71
	Including—				
1	Pin (4 by 28 mm., driven).....				
1	Spring cover.....	71F.....	3	41	71
	Including—				
1	Knob.....	71E.....	3	41	71
1	Spring cover screw.....	102E.....	3	41	102
1	Lock bearing (right).....	71A.....	3	41	71
	Including—				
1	Cam screw.....	71C.....	3	41	71
	Including—				
1	Pin (4 by 28 mm., driven).....				
1	Spring cover.....	71F.....	3	41	71
	Including—				
1	Knob.....	71E.....	3	41	71
1	Spring cover screw.....	102E.....	3	41	102
1	Lock bearing reinforce (left).....	52D.....	3	41	52
1	Lock bearing reinforce (right).....	52C.....	3	41	52
1	Lunette.....	81B.....	3	41	81
1	Lunette chain fastening.....	84H.....	3	41	84
	Including—				
1	Lunette chain.....	84M.....	3	41	84
1	Lunette chain cross bar.....	84N.....	3	41	84
1	Lunette chain ring.....	84L.....	3	41	84
1	Middle transom.....	55B.....	3	41	55
1	Name plate.....	166L.....	3	41	166
1	Name plate.....	166E.....	3	41	166
	Including—				
2	Screws (4 by 6 mm., countersunk head).....	136.....	3	41	136
1	Rammer staff fastening (front).....	68B.....	3	41	68
1	Rammer staff fastening (rear).....	68A.....	3	41	68
1	Safety chain eye.....	63F.....	3	41	63
	Including—				
1	Safety chain ring.....	63G.....	3	41	63
1	Screw (12 by 19.2 mm.).....	63H.....	3	41	63
4	Screws (10 by 14 mm.).....	88C.....	3	41	88
4	Screws (10 by 15.25 mm.).....	88D.....	3	41	88
1	Shield brace diagonal (left).....	155B.....	3	41	155
1	Shield brace diagonal (right).....	155A.....	3	41	155
1	Shield bracket (left).....	154E.....	3	41	154
	Including—				
1	Fastening (left).....	154B.....	3	41	154
	Including—				
2	Screws (8 by 15 mm., round head).....	154C.....	3	41	154
1	Screw (16 by 43 mm.).....	154F.....	3	41	154
1	Shield bracket (right).....	154D.....	3	41	154
	Including—				
1	Fastening (right).....	154A.....	3	41	154
	Including—				
2	Screws (8 by 15 mm.) round head.....	154C.....	3	41	154
1	Screw (16 by 43 mm.).....	154F.....	3	41	154
1	Sponge staff fastening (front).....	69C.....	3	41	69
1	Sponge staff fastening base.....	69A.....	3	41	69
	Including—				
1	Pin (8 by 34 mm., riveted).....				
1	Sponge staff fastening hinge.....	69B.....	3	41	69
1	Staff fastening key.....	69G.....	3	41	69
	Including—				
1	Chain.....	JB5R.....	15	2KJ	5A
1	Chain eye.....	69H.....	3	41	69
2	Chain rings.....	JB5M.....	15	2KJ	5
1	Key spring.....	69E.....	3	41	69
	Including—				
1	Screw (4 by 7 mm., countersunk head).....	69K.....	3	41	69
1	Strap (long).....	70B.....	3	41	70

Number.	Name of part.	Piece mark.	Drawing.		
			Class.	Division.	Number.
	<b>Trail, complete consisting of—Continued.</b>				
1	Strap (short).....	70A.....	3	41	70
	Including—				
1	Buckle (1.5-inch barrel roller).....		20	0	1
1	Keeper.....	70C.....	3	41	70
1	Top plate reinforce.....	58C.....	3	41	58
1	Trail bottom plate.....	50A.....	3	41	50
1	Trail box angle (front).....	61D.....	3	41	61
1	Trail box angle (left).....	63B.....	3	41	63
1	Trail box angle (rear).....	61E.....	3	41	61
1	Trail box angle (right).....	63A.....	3	41	63
1	Trail box body.....	62E.....	3	41	62
1	Trail box cover.....	62D.....	3	41	62
	Including—				
1	Cover hinge (male) (long).....	64A.....	3	41	64
1	Cover hinge (male) (short).....	64C.....	3	41	64
1	Cover stiffener (long).....	62B.....	3	41	62
1	Cover stiffener (medium).....	62A.....	3	41	62
1	Cover stiffener (short).....	62C.....	3	41	62
2	Hinge pins.....	64E.....	3	41	64
	Including—				
2	Hinge pin washers.....	64F.....	3	41	64
1	Lock bar.....	64B.....	3	41	64
1	Trail box cover padding.....	61B.....	3	41	61
1	Trail box gasket.....	61C.....	3	41	61
1	Trail box gasket retainer.....	61A.....	3	41	61
1	Trail flange reinforce (lower left).....	54A.....	3	41	54
1	Trail flange reinforce (lower right).....	54B.....	3	41	54
1	Trail flange reinforce (upper left).....	51A.....	3	41	51
1	Trail flange reinforce (upper right).....	52A.....	3	41	52
1	Trail flask (left).....	45A.....	3	41	45
1	Trail flask (right).....	47A.....	3	41	47
1	Trail flask reinforce (front left).....	53B.....	3	41	53
1	Trail flask reinforce (front right).....	53A.....	3	41	53
1	Trail flask reinforce (rear left).....	54C.....	3	41	54
1	Trail flask reinforce (rear right).....	54D.....	3	41	54
1	Trail front angle.....	56A.....	3	41	56
2	Trail handles.....	74H.....	3	41	74
2	Trail handle fastening (left).....	74F.....	3	41	74
2	Trail handle fastening (right).....	74E.....	3	41	74
2	Trail handle fastening (corner).....	74G.....	3	41	74
1	Trail joint plate (left).....	51B.....	3	41	51
1	Trail joint plate (right).....	52B.....	3	41	52
1	Trail reinforce (inner left).....	57E.....	3	41	57
1	Trail reinforce (inner right).....	57D.....	3	41	57
1	Trail reinforce (outer left).....	58B.....	3	41	58
1	Trail reinforce (outer right).....	58A.....	3	41	58
1	Trail reinforce (left).....	57F.....	3	41	57
1	Trail reinforce (right).....	57C.....	3	41	57
1	Trail top plate.....	49A.....	3	41	49
1	Traversing roller box (left).....	95A.....	3	41	95
	Including—				
1	Grease cup.....	97K.....	3	41	97
	Including—				
1	Grease cup plug.....	73H.....	3	41	73
1	Grease cup spring.....	73L.....	3	41	73
1	Grease cup valve.....	73K.....	3	41	73
1	Traversing roller box (right).....	96A.....	3	41	96
	Including—				
1	Grease cup.....	97K.....	3	41	97
	Including—				
1	Grease cup plug.....	73H.....	3	41	73
1	Grease cup spring.....	73L.....	3	41	73
1	Grease cup valve.....	73K.....	3	41	73
1	Traversing screw housing.....	87A.....	3	41	87
	Including—				
1	Grease cup.....	93H.....	3	41	93
	Including—				
1	Grease cup plug.....	73H.....	3	41	73
1	Grease cup spring.....	73L.....	3	41	73
1	Grease cup valve.....	73K.....	3	41	73
1	Traversing screw housing collar (left).....	88A.....	3	41	88
1	Traversing screw housing collar (right).....	88B.....	3	41	88
1	Trunnion bearing (left).....	72B.....	3	41	72
	Including—				
1	Trunnion cap.....	73F.....	3	41	73
	Including—				
1	Grease cup.....	73E.....	3	41	73
	Including—				
1	Grease cup plug.....	73H.....	3	41	73
1	Grease cup spring.....	73L.....	3	41	73
1	Grease cup valve.....	73K.....	3	41	73

Number.	Name of part.	Piece mark.	Drawing.		
			Class.	Division.	Number.
	Trail, complete, consisting of—Continued.				
	Trunnion bearing—Continued.				
1	Trunnion-cap hinge pin.....	73G.....	3	41	73
1	Trunnion-cap latch pin (left).....	73B.....	3	41	73
	Including—				
1	Screw dowel.....	73T.....	3	41	73
1	Pin (6 by 60 mm. driven).....				
1	Trunnion bearing (right).....	72A.....	3	41	72
	Including—				
1	Trunnion cap.....	73F.....	3	41	73
	Including—				
1	Grease cup.....	73E.....	3	41	73
	Including—				
1	Grease cup plug.....	73H.....	3	41	73
1	Grease cup spring.....	73V.....	3	41	73
1	Grease cup valve.....	73K.....	3	41	73
1	Trunnion-cap hinge pin.....	73J.....	3	41	73
1	Trunnion-cap latch pin (right).....	73A.....	3	41	73
	Including—				
1	Screw dowel.....	73T.....	3	41	73
1	Pin (6 by 60 mm. driven).....				
1	Trunnion-bearing reinforce (left).....	57B.....	3	41	57
1	Trunnion-bearing reinforce (right).....	57A.....	3	41	57
2	Wheel guard.....	84K.....	3	41	84
4	Wheel-mat brackets.....	68C.....	3	41	68
	Including—				
2	Chains No. 18.....	JB5T.....	15	2KJ	5
	Including—				
4	Chain rings.....	JB5M.....	15	2KJ	5
4	Chain links.....	68F.....	3	41	68
4	Chain rings.....	68F.....	3	41	68
4	Do.....	JB5M.....	15	2KJ	5
4	Eyebolts.....	68E.....	3	41	68
	Including—				
4	Nuts, crown (0.625-inch).....	Q6XA.....	30	2	6
4	Split pins (0.14 by 1.56 inches).....		30	2	1
1	Wing nut.....	63C.....	3	41	63
	Including—				
1	Wing-nut pin.....	63E.....	3	41	63
1	Wing-nut pin washer.....	63D.....	3	41	63
	Trail-box bottom partition, complete, consisting of—				
1	Brace No. 7.....	170D.....	3	41	170
1	Filling strip No. 10.....	170L.....	3	41	170
1	Filling strip No. 11.....	170H.....	3	41	170
1	Filling strip No. 12.....	170G.....	3	41	170
1	Partition No. 1.....	169A.....	3	41	169
1	Partition No. 2.....	169B.....	3	41	169
1	Partition No. 3.....	169C.....	3	41	169
1	Partition No. 4.....	169D.....	3	41	169
1	Partition No. 5.....	170B.....	3	41	170
1	Partition No. 6.....	170A.....	3	41	170
1	Partition No. 9.....	170F.....	3	41	170
	Including—				
1	Ledge.....	170E.....	3	41	170
2	Screws, wood (0.125-inch, No. 5).....	170M.....	3	41	170
30	Screws, wood (0.125-inch, No. 5).....	170M.....	3	41	170
1	Shelf No. 8.....	170K.....	3	41	170
1	Shelf No. 13.....	170C.....	3	41	170
1	Trail-box middle tray.....	168A.....	3	41	168
1	Trail-box top tray.....	167A.....	3	41	167
	Including—				
1	Lifting strap.....	167B.....	3	41	167
2	Loops.....	167C.....	3	41	167
	Including—				
4	Screws, wood (0.75-inch, No. 5).....	167D.....	3	41	167
1	Traveling lock (cradle) (left).....	71K.....	3	41	71
	Including—				
1	Plunger.....	71D.....	3	41	71
1	Plunger nut.....	71N.....	3	41	71
1	Plunger spring.....	71G.....	3	41	71
1	Sleeve.....	71M.....	3	41	71
1	Spindle.....	71L.....	3	41	71
1	Traveling lock (cradle) (right).....	71H.....	3	41	71
	Including—				
1	Plunger.....	71D.....	3	41	71
1	Plunger nut.....	71N.....	3	41	71
1	Plunger spring.....	71G.....	3	41	71
1	Sleeve.....	71M.....	3	41	71
1	Spindle.....	71L.....	3	41	71

Number.	Name of part.	Piece mark.	Drawing.		
			Class.	Division.	Number.
1	Traversing mechanism, complete, consisting of—				
2	Belleville spring compressors .....	97 A .....	3	41	97
	Including—				
2	Split pins (0.312 by 3.25 inches) .....		30	2	1
2	Dust covers .....	93S .....	3	41	93
2	Dust-cover gaskets .....	93R .....	3	41	93
2	Handwheel shaft pinions .....	93Q .....	3	41	93
2	Roller-box covers .....	98C .....	3	41	98
2	Shaft-bearing locks .....	93L .....	3	41	93
	Including—				
2	Screws (6 by 7 mm. countersunk head) .....	93M .....	3	41	93
2	Thrust-bearing adjusters .....	90G .....	3	41	90
	Including—				
2	Split pins (0.15 by 1.25 mm.) .....		30	2	1
2	Thrust bearings .....	90F .....	3	41	90
2	Thrust-bearing adjuster locks .....	90E .....	3	41	90
1	Traversing gear case (left) .....	92B .....	3	41	92
	Including—				
2	Gear-case bolts (12 by 40 mm.) .....	92C .....	3	41	92
	Including—				
2	Nuts, crown (12 mm.) .....	Q17FA .....	30	2	17
2	Split pins (0.093 by 1.25 inches) .....		30	2	1
2	Gear-case bolts (12 by 42 mm.) .....	92E .....	3	41	92
	Including—				
2	Nuts, crown (12 mm.) .....	Q17FA .....	30	2	17
2	Split pins (0.093 by 1.25 inches) .....		30	2	1
1	Gear case dowel (20 by 27 mm.) .....	92A .....	3	41	92
1	Traversing gear case bushing (15 by 18.95 mm.) .....	91A .....	3	41	91
1	Traversing gear case bushing (22 by 16 mm.) .....	91P .....	3	41	91
1	Traversing gear case bushing (25 by 34 mm.) .....	91L .....	3	41	91
2	Traversing gear case cover .....	91E .....	3	41	91
	Including—				
2	Chains .....	JB5N .....	15	2KJ	5
	Including—				
4	Chain rings .....	JB5M .....	15	2KJ	5
2	Chain rivets .....	JB5L .....	15	2KJ	5
2	Spring cotters .....	91H .....	3	41	91
2	Cover bolts .....	91K .....	3	41	91
	Including—				
2	Cover-bolt nuts .....	91M .....	3	41	91
2	Split pins (0.093 by 1 inch) .....		30	2	1
2	Cover hasps .....	91G .....	3	41	91
2	Cover hinges .....	91F .....	3	41	91
2	Traversing gears .....	93N .....	3	41	93
1	Traversing handwheel (left) .....	94G .....	3	41	94
	Including—				
1	Direction plate (left) .....	166B .....	3	41	166
1	Handwheel hub (left) .....	94E .....	3	41	94
1	Sleeve .....	94D .....	3	41	94
1	Sleeve spindle .....	94C .....	3	41	94
1	Spindle nut .....	94F .....	3	41	94
1	Traversing handwheel (right) .....	94B .....	3	41	94
	Including—				
1	Direction plate (right) .....	166A .....	3	41	166
1	Handwheel hub (right) .....	94A .....	3	41	94
1	Sleeve .....	94D .....	3	41	94
1	Sleeve spindle .....	94C .....	3	41	94
1	Spindle nut .....	94F .....	3	41	94
1	Traversing handwheel shaft (left) .....	93D .....	3	41	93
	Including—				
1	Handwheel retainer .....	93A .....	3	41	93
1	Handwheel shaft nut .....	111E .....	3	41	111
1	Split pin (0.125 by 1.25 inches) .....		30	2	1
1	Split pin (0.15 by 1.5 inches) .....		30	2	1
1	Traversing handwheel shaft (right) .....	93B .....	3	41	93
	Including—				
1	Handwheel retainer .....	93A .....	3	41	93
1	Handwheel shaft nut .....	111E .....	3	41	111
1	Split pin (0.125 by 1.25 inches) .....		30	2	1
1	Split pin (0.15 by 1.5 inches) .....		30	2	1
2	Traversing intermediate gears .....	93K .....	3	41	93
1	Traversing intermediate shaft (left) .....	93G .....	3	41	93
	Including—				
1	Intermediate shaft nut .....	111F .....	3	41	111
1	Split pin (0.15 by 1.62 inches) .....		30	2	1
1	Traversing intermediate shaft (right) .....	93 F .....	3	41	93
	Including—				
1	Intermediate shaft nut .....	111F .....	3	41	111
1	Split pin (0.15 by 1.62 inches) .....		30	2	1
2	Traversing intermediate shaft bearings .....	93P .....	3	41	93
1	Traversing nut .....	89A .....	3	41	89

Num- ber.	Name of part.	Piece mark.	Drawing.		
			Class.	Divi- sion.	Num- ber.
	<b>Traversing mechanism, complete, consisting of—Contd.</b>				
1	Traversing screw.....	89C.....	3	41	89
	Including—				
2	Thrust bearings.....	90F.....	3	41	90
1	Traversing screw stop collar.....	89B.....	3	41	89
	Including—				
1	Pin (7 by 50 mm., driven).....				
1	Traversing screw bearing (left).....	90A.....	3	41	90
1	Traversing screw bearing (right).....	90B.....	3	41	90
2	Traversing screw housing cover.....	90D.....	3	41	90
	Including—				
2	Housing cover screws.....	90C.....	3	41	90
2	Traversing rollers.....	97F.....	3	41	97
	Including—				
2	Traversing roller bushings.....	97D.....	3	41	97
2	Traversing roller forks.....	98A.....	3	41	98
	Including—				
8	Belleville springs.....	97C.....	3	41	97
2	Fork thrust collars.....	97B.....	3	41	97
2	Nuts, crown (18 mm.).....	98E.....	3	41	98
2	Split pins (0.152 by 1.5 inches).....		30	2	1
2	Traversing roller shafts.....	97E.....	3	41	97
2	<b>Wheels, complete, consisting of—</b>				
2	Axle caps.....	PB37K.....	15	2KP	37
	Including—				
2	Wheel oil valves.....	PB37E.....	15	2KP	37
	Including—				
2	Gaskets (6 by 35.5 by 4 mm., leather).....	PB37G.....	15	2KP	37
2	Screws (6 by 15 mm., round head).....	PB37F.....	15	2KP	37
2	Washers (6 by 14 by 1 mm., brass).....	PB37H.....	15	2KP	37
2	Axle collars.....	PB37A.....	15	2KP	37
2	Base band.....	PB49E.....	15	2KP	49
28	Carriage bolts.....	PB48C.....	15	2KP	48
	Including—				
28	Nuts (0.563 inch).....	PB48G.....	15	2KP	48
4	Felloes (long).....	PB49B.....	15	2KP	49
4	Felloes (short).....	PB49C.....	15	2KP	49
2	Felloe bands.....	PB49D.....	15	2KP	49
2	Hub boxes.....	PB36D.....	15	2KP	36
	Including—				
2	Hub liners (inner).....	PB36B.....	15	2KP	36
2	Hub liners (outer).....	PB36C.....	15	2KP	36
4	Hub liner screws (A=13 mm.).....	PB36E.....	15	2KP	36
4	Hub liner screw (A=14 mm.).....	PB36F.....	15	2KP	36
2	Hub rings.....	PB36A.....	15	2KP	36
2	Linch pins.....	PB37D.....	15	2KP	37
	Including—				
2	Linch pin fids.....	PB37M.....	15	2KP	37
2	Linch pin latches.....	PB37B.....	15	2KP	37
2	Linch pin latch pins.....	PB37C.....	15	2KP	37
28	Spokes.....	PB49A.....	15	2KP	49
8	Spoke shoe (joint).....	PB48B.....	15	2KP	48
20	Spoke shoe (intermediate).....	PB48A.....	15	2KP	48
28	Spoke shoe plates.....	PB48D.....	15	2KP	48
28	Spoke shoe rivets.....	PB48E.....	15	2KP	48
2	Tires.....	PB49F.....	15	2KP	49
16	Tire bolts.....	PB48F.....	15	2KP	48
	Including—				
16	Nuts (0.375 inch).....	PB48H.....	15	2KP	48
16	Washers (0.437 inch).....	PB48K.....	15	2KP	48
2	Washers (inner).....	PB37N.....	15	2KP	37
2	Washers (outer).....	PB37L.....	15	2KP	37

**DESCRIPTION OF THE CARRIAGE.**

The 155-mm. howitzer, model of 1918 (Schneider), Plate XIII, is of the hydropneumatic, long recoil type, in which the howitzer is allowed sufficient length of recoil to insure stability at low elevation. The length of recoil is not shortened for high elevations.

For the purpose of description, the carriage is considered as composed of the following groups: Sleigh (including recoil mechanism), cradle, trail, traveling lock, elevating mechanism, traversing mechanism, wheels, road brake, and shield.

**THE SLEIGH.**

(Plates XV and XIX.)

The sleigh contains the recoil and counter-recoil mechanism and serves as a support for the howitzer, being secured to it by the breech key and the holding-down band. The recoil, counter-recoil cylinders, and two air cylinders are bored in the sleigh and form the recoil mechanism. The ends of the recoil and counter-recoil cylinders are attached to the cradle and when the howitzer is fired the sleigh and howitzer recoil, sliding on the cradle slides.

The holding-down band is anchored on either side to the front band clips, which are secured to the sleigh. Grooves are cut underneath the two top edges of the sleigh, and are lined with bronze liners, Plate XXVI, known as the sleigh slides. These liners slide on the cradle clips and guide the howitzer during recoil. Five longitudinal cylinders are bored in the sleigh, the two upper cylinders running about one-third the length of the sleigh forming air tanks and are closed at the front end by the air tank heads. The left air tank head is provided with an opening in which the gage-cock body is assembled, Plate XVII. A pressure gage may be assembled through an adapter to this gage cock for ascertaining the pressure in the counter-recoil system. The gage cock is also provided with a pointer, which registers the quantity of liquid in the system on a scale provided on the air tank head. The two lower cylinders, Plate XVIII, extending the full length of the sleigh, form a housing for the recoil mechanism, the right cylinder being the counter-recoil cylinder and the left the recoil cylinder. The small equalizing cylinder in the center of the sleigh, extending only a short distance, is closed at the front end with the filling valve, through which air or liquid is introduced into the system.

The counter-recoil cylinder is connected by a passage to the right air tank and also to the small equalizing cylinder, the latter being connected to the left air cylinder, thus maintaining equal pressure in both air cylinders and in the counter-recoil cylinder. The counter-recoil cylinder is closed at the rear end with the counter-recoil

cylinder head and at the front end with the stuffing box, through which the counter-recoil rod and its piston moves. The recoil cylinder is closed at the rear end with the recoil cylinder head and at the front end with the recoil cylinder stuffing box, through which the recoil piston rod operates. This rod is hollow and serves as a buffer chamber for the buffer rod, which is securely screwed to the recoil cylinder head at one end, the other end carrying the counter-recoil valve. The recoil and counter-recoil rods are fitted with the piston rod nuts on the front end which engage the piston rod lock plate, Plate XIX.

#### CRADLE.

(Plates XIII, XVI, XX, XXVI, and XXIX.)

The cradle is a steel U-shaped plate reinforced by several transoms and supported by the trunnion bracket, elevating segment brackets, and in traveling position by the cradle band which engages the cradle locks secured to trail. Along each edge of the cradle is riveted clips on which the howitzer recoils when in action. The sleigh traveling locks are mounted at the extreme ends of the cradle and used to lock the sleigh to cradle when the howitzer is in traveling position.

The cradle is mounted on trunnions on the carriage, and by means of elevating segments geared with the elevating mechanism may be inclined at various firing angles. When carriage is traveling the rear end of the cradle rests on the cradle traveling lock, thereby relieving the elevating mechanism of the weight of the howitzer, sleigh, and cradle.

The left trunnion of the cradle is bored out to receive the sight and bracket. The shoulder guard is located on left side of the cradle just back of the trunnion bracket and protects the gunner from the recoiling parts. The firing mechanism is located on the right side of the cradle and provided with a safety device which prevents the piece from being fired when the piston rod nuts are not engaged by piston lock.

The recoil indicator (Plate XX) is located just back of the trunnion bracket on the right side of the cradle and consists of a steel spring which is adjusted by means of a nut so that the pointer bears against a scale engraved on the edge of the sleigh indicating the length of recoil. The front end of the cradle is covered by the cradle head and provided with an opening through which the pressure-gage adapter may be assembled to the gage-cock body. The lower half of the front end of the cradle is closed by the front transom, forming a guide for the piston-rod lock which is operated by means of a lever. When this lever is lowered the lock plate moves to the right, releasing the piston-rod nuts. When lever is raised the lock moves to the left, locking the nuts in firing position. The locking device is pro-

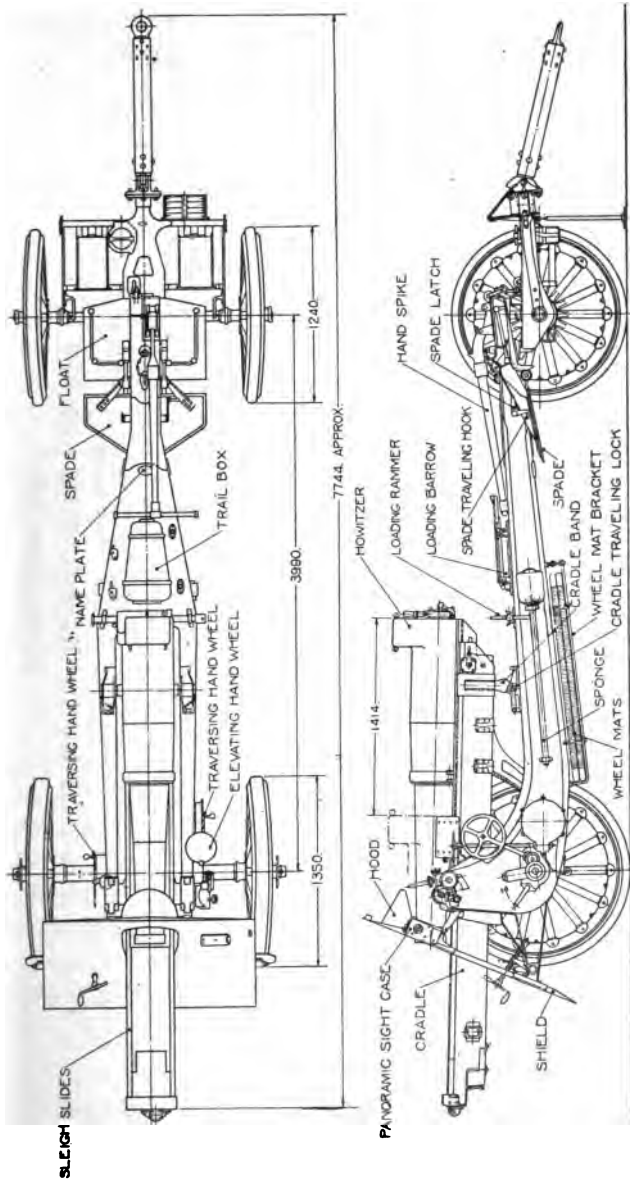

155 MM HOWITZER, MODEL OF 1918 (SCHNEIDER)  
TRAVELING POSITION

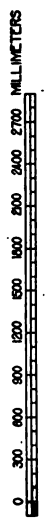

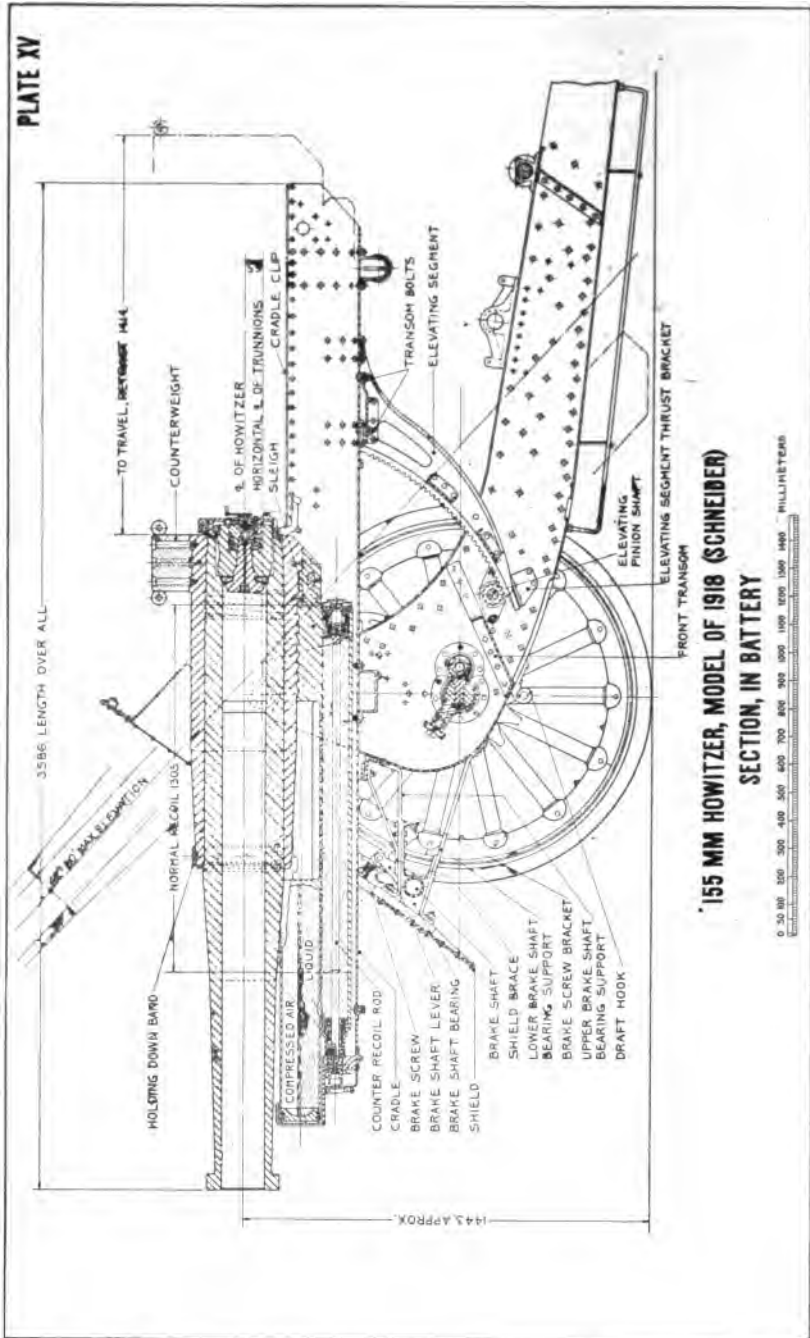

155 MM HOWITZER, MODEL OF 1918 (SCHNEIDER)  
SECTION, IN BATTERY

tected by the cradle front cover which holds the lever in firing position when closed. The filling valve is accessible through the cradle bottom cover located on the bottom of the cradle to the rear of the front transom. The pump bracket is located on the left side of the cradle near the front.

#### RECOIL AND COUNTER-RECOIL MECHANISMS.

(Plate XV and XVIII.)

When the howitzer is fired the recoil mechanism exercises its retarding influence by means of a liquid which is obliged to pass through an orifice whose size diminishes as the movement proceeds, thus checking the recoiling mass. The recoiling movement of the gun actuates at the same time the counter-recoil mechanism, which acts on the counter-recoil liquid and forces it into two reservoirs, thus further compressing a gas therein contained. When the recoil movement is ended the expansion of gas forces the counter-recoil mechanism back "into battery," and the recoil cylinder again exercises its retarding influence to prevent a too rapid return and shock. The normal recoil is 51.375 inches (1.305 meters).

When the piece is fired the howitzer and sleigh move to the rear, the recoil and counter-recoil rods, which are held by the piston-rod lock, remaining stationary. The liquid in the counter-recoil cylinder, approximately 22 liters (23.25 quarts), is thus forced into the air cylinders, building up a pressure sufficient to return the howitzer to battery. The liquid in the recoil cylinder, approximately 11.25 quarts, is forced through the orifices in the recoil piston rod and then through the throttling ring. The tapered buffer rod, which is attached to the recoil cylinder head, moves through the throttling ring, gradually closing the orifice, thus keeping the pressure constant as the velocity of recoil is reduced. As the buffer rod moves to the rear the counter-recoil valve is opened, allowing the liquid to pass freely into the buffer chamber. As the gun returns to battery the buffer valve closes, forcing the liquid to pass through the small clearance around the valve, thus absorbing the energy of counter recoil.

#### TRAIL.

(Plates XIII, XIV, XXIII.)

The trail is built up of steel plates forming the body of the carriage and is composed of two flasks held together by top and bottom trail plates. The front part of the trail is open between the flasks to permit recoiling of the howitzer at high elevations. The trunnion bearings are riveted to the top of the flasks, and the axle and traversing screw housing are located between the flasks toward the front end forming a brace for the trail.

The axle housing is lined with a bronze bushing at each end, through which the axle passes. The traversing roller boxes are located one on each side of the trail just above the axle-forming housings for the traversing rollers. These rollers are straddled by forks which carry the weight of the carriage through a system of Belleville springs. Under the firing load these springs compress, and the weight is transmitted directly to the axle.

The cradle-lock bearings are located one on top of each trail flask and form bearings for the cradle lock which engages the cradle rear band when the gun is in traveling position.

The trail box is built into the trail and forms a convenient place for carrying tools and spare parts. The extreme rear end of the trail is fitted with a float which prevents the end of the trail from sinking into the ground when firing at high elevation. The spade is mounted on the spade shaft which passes through the bearings in the fixed spade. It is held in either of two firing positions by means of the spade-latch shaft, which engages either of the two half bearings on the ends of the spade braces.

The spade-latch shaft is operated by a handle on the left spade latch and can be rigidly held at an angle of  $20^{\circ}$  from the vertical for firing on soft ground or at an angle of  $40^{\circ}$  from the vertical for firing on hard ground. When traveling the spade is turned into a position parallel to the bottom plate of the trail and held by the spade latches which engage the spade traveling hooks. The spade-latch shaft is held either in firing position or traveling position by the latch-shaft spring, which is riveted to the underside of the trail top plate and bears on the flattened surfaces at the center of the shaft.

The handspike is mounted on a base, which is located on top of the extreme rear end of the trail. In firing position the handspike is held rigid by turning the fulcrum, which forces the foot under the handspike pin. In traveling position the handspike is turned back on the trail and held in position by operating the fulcrum, which forces the top end of the handspike under a catch provided for that purpose.

The lunette is riveted to the underside of the float and forms a pintle bearing when the carriage is limbered. The fifth wheel is also riveted to the underside of the float and bears on the trail bearing of the limber. The name plate, giving the number of the carriage, model, name of manufacturer, year of completion, and initials of inspector, is riveted to the top trail plate.

In all reports and correspondence the carriage is to be designated by the number and model given on the name plate.

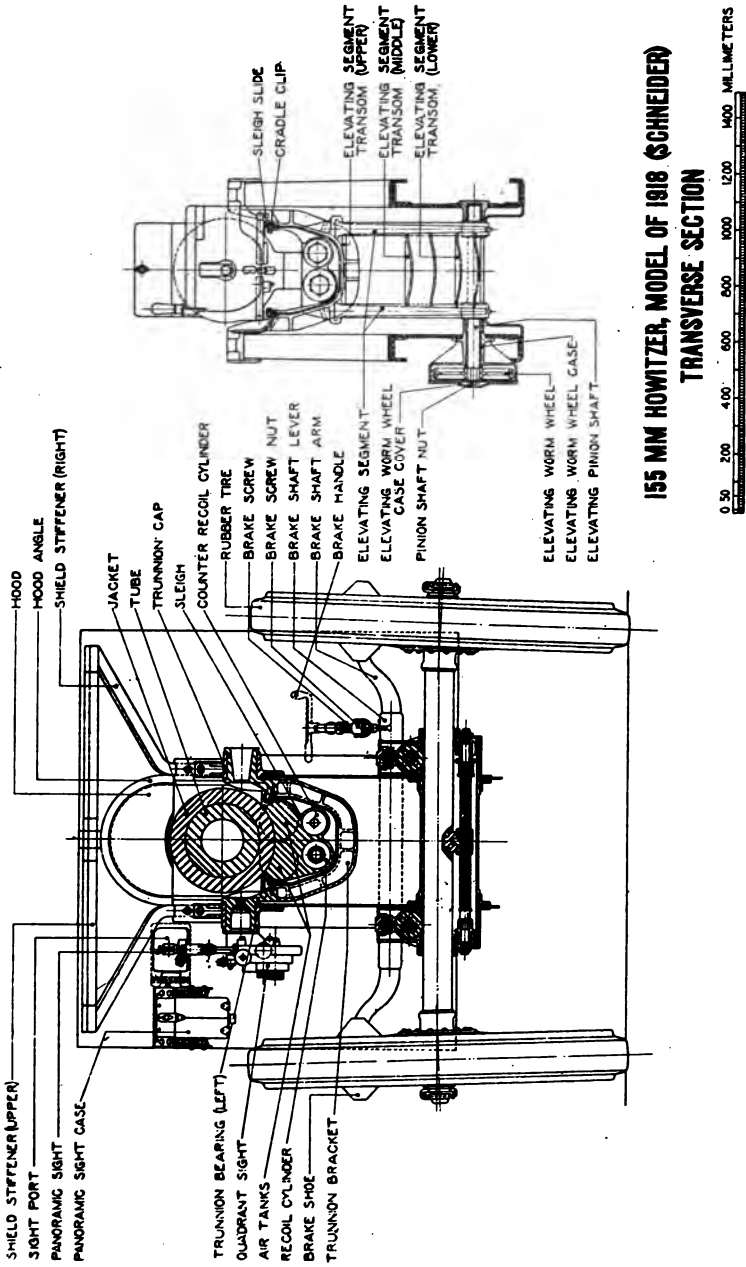

155 MM HOWITZER, MODEL OF 1918 (SCHNEIDER)  
TRANSVERSE SECTION

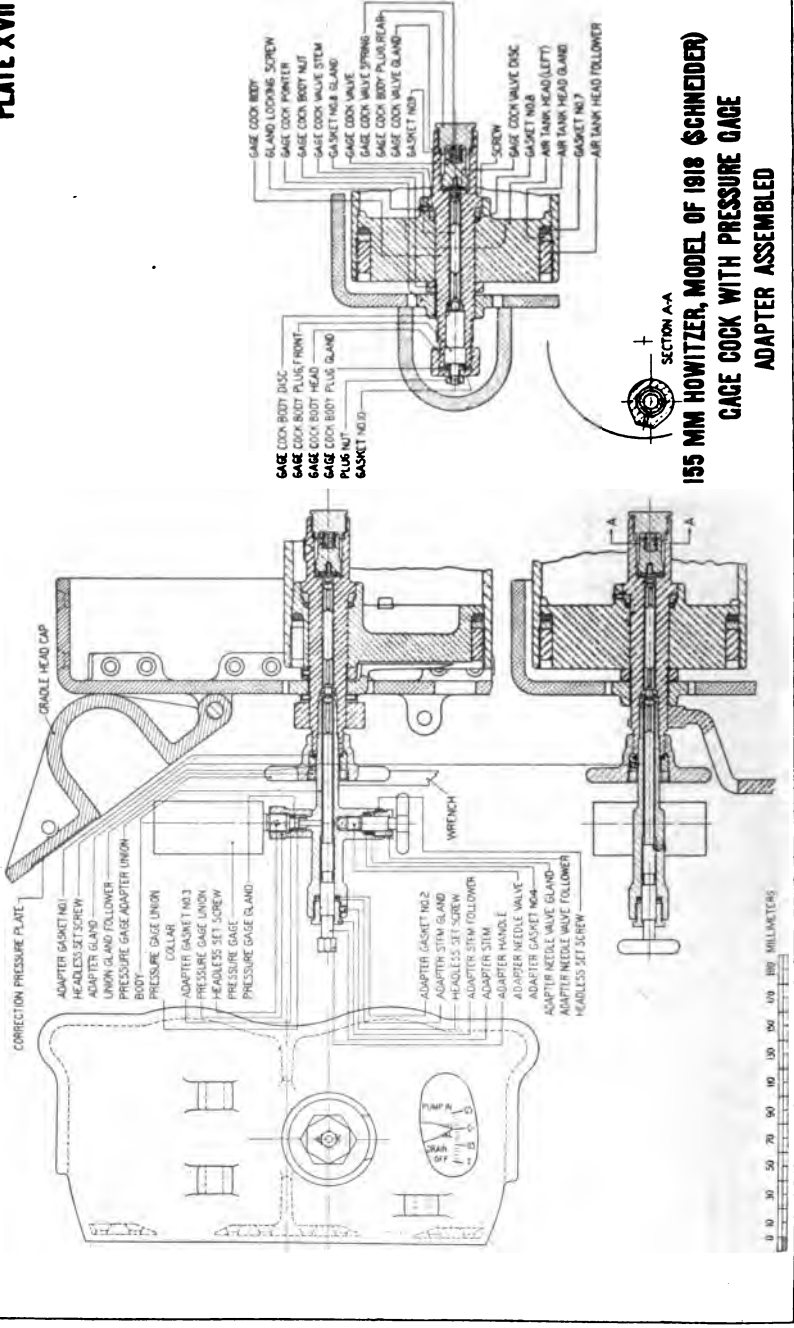

## ELEVATING MECHANISM.

(Plate XXIII.)

By means of the elevating mechanism the howitzer, sleigh, and cradle are inclined at the various firing angles, varying from zero to  $42^{\circ}$ , by rotation in the trunnions of the cradle.

Two elevating segments attached to the cradle are actuated by the elevating pinion shaft operating in bearings integral with the elevating worm wheel case secured to trail. To lower end of worm shaft is fitted a worm which engages a worm wheel and pinion shaft in the gear case. On upper end of worm shaft is attached the elevating handwheel fitted with a handle and plunger enabling the operator to lock the howitzer at any desired elevation. The motion of the handwheel is transmitted through the worm gear to the pinion shaft and thence to the elevating segments.

The handwheel is provided with a handle of a spring locking type, downward pressure on which unlocks it from the handwheel latch plate, permitting the mechanism to be operated.

## TRAVERSING MECHANISM.

(Plates XXI and XXII.)

The traverse of the carriage is obtained by means of the traversing mechanism causing the carriage to slide on the axle, the trail pivoting on the spade. The movement is  $3^{\circ}$  each side of center or a total of 105 mils.

At the center of the axle is rigidly attached a bronze traversing nut through which passes the traversing screw which may be operated from either side of the carriage by means of handwheels connected to the screw through bevel gears and shaft. The traversing screw operates in the traversing housing longitudinally and held in position by thrust bearings and thrust bearing adjusters at both ends of the screw. When either of the handwheels is operated the traversing screw is rotated and moves to the right or left as the case may be, carrying the entire carriage which moves across the axle on the traversing rollers.

In order to reduce friction during the traversing operation the carriage rests on the axle through Belleville springs and two concave faced traversing rollers mounted on roller shafts in the axle housing. When gun is fired the Belleville springs are compressed and the carriage rests on the axle through the bronze traversing roller boxes.

On top of axle projecting to the left of carriage is riveted an azimuth scale graduated in mils so that the position of the carriage on the axle may easily be seen at any time. When in traveling position the carriage should be locked to the axles by the axle traveling lock (Plate XXIV), thus relieving the traversing mechanism from unnecessary stress.

## AXLE TRAVELING LOCK.

(Plate XXIV.)

The axle traveling lock is a device employed to relieve the traversing mechanism from unnecessary stress when the carriage is in traveling position. When the carriage is prepared for traveling the traveling lock engages a series of square grooves cut in the center of the axle. The lock is operated by an eccentric on the end of the traveling lock shaft which is controlled by the lock lever fixed on outer end. The lock lever may be placed in two positions marked "to travel" and "to fire," by means of its handle which is provided with a spring plunger engaging the traveling lock catch. In order to properly lock the carriage in traveling position it is necessary to traverse the carriage to the center position on the axle, thus permitting the locking device to engage the grooves cut in the center of the axle.

The axle lock is bolted on the front of the axle housing and lock is operated by a cam on the end of shaft which extends through a bearing in the left trail plate and is fitted with a handle. The plunger of the handle engages either of two catches, one locking the howitzer in firing position and the other in traveling position. When the carriage is in traveling position the lock is forced down by means of a spring engaging the teeth in the middle of the axle. When the howitzer is in firing position the lock is lifted by means of the cam so that it clears the teeth in the axle, permitting the carriage to be operated at will.

## THE WHEELS.

(Plates I-A, XIII-A, and XV.)

The wheels are built up of wooden spokes mounted between hub boxes and hub rings and bolted in place. The other ends of the spokes are attached to the felloe by means of spokes shoes. The steel felloe band is bolted to the felloe. The base band is shrunk on to the felloe band and rubber tires are mounted on the base band.

The inner and outer hub liners are forced into the hub box and form the bearing surface for the axle. The wheels are held in place by the axle caps, which are put over the end of the axle and held in place by lynch pins. Leather dust guards are placed between the hub boxes and the axle cap and between the hub boxes and the axle collars. The axle caps are provided with ring holes, to which the drag ropes may be attached for towing by man power. The lynch pins are held in place by lynch-pin latches, which are hinged to the lynch pins at one end and tied with lynch-pin fids to the other. For dimensions and weights of wheels see page 35.



FRONT OF CRADLE

SLEIGH NOT SHOWN IN SECTION

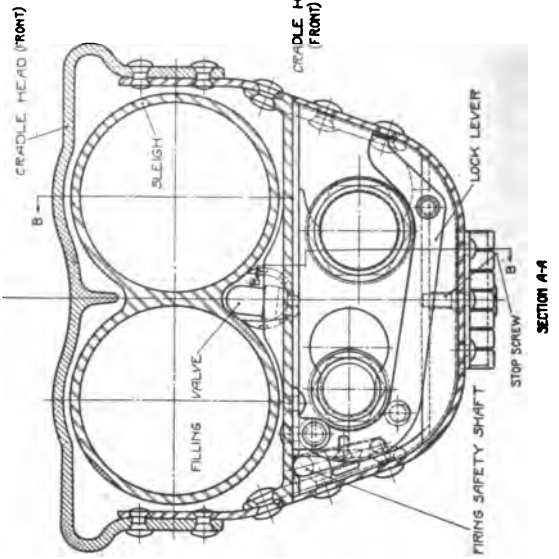
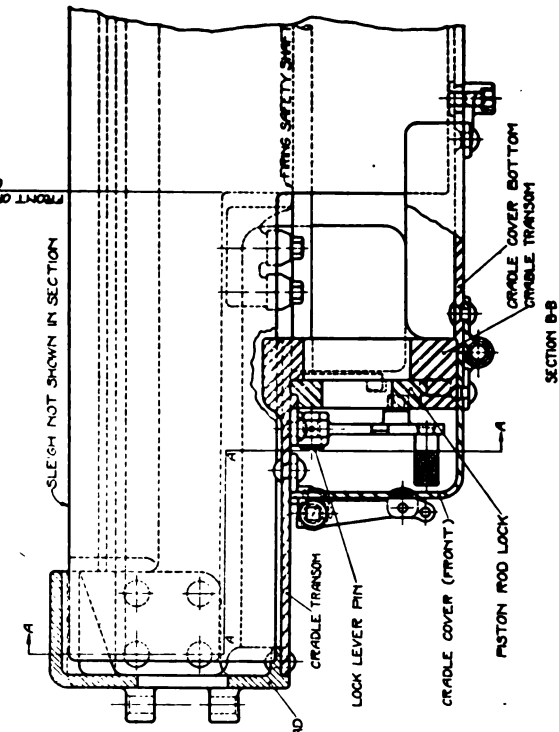

155 MM HOWITZER, MODEL OF 1918 (SCHNEIDER)  
PISTON ROD LOCK MECHANISM



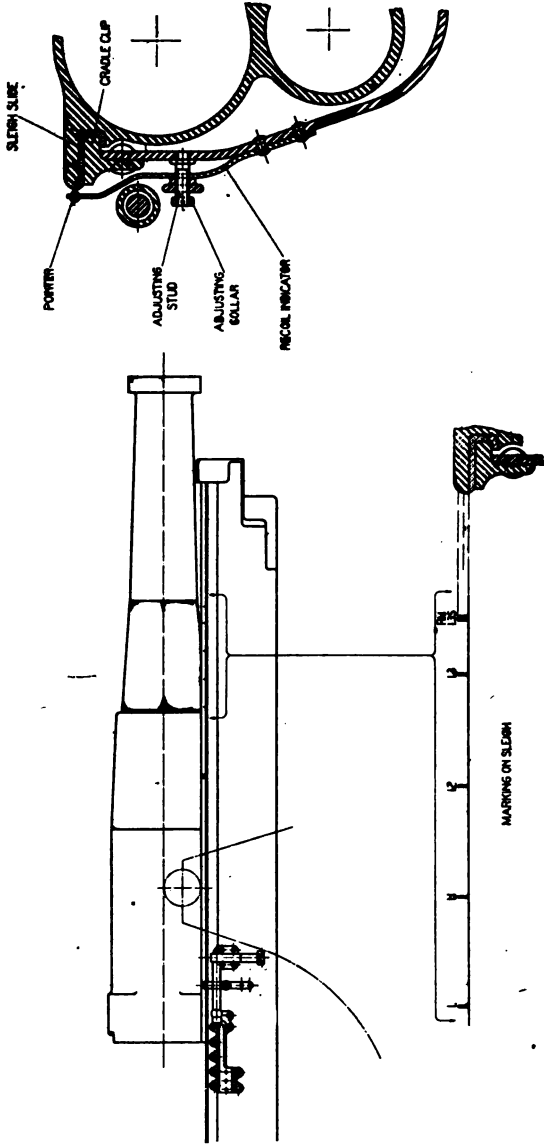

155 MM HOWITZER, MODEL OF 1918 (SCHNEIDER)  
RECOIL INDICATOR



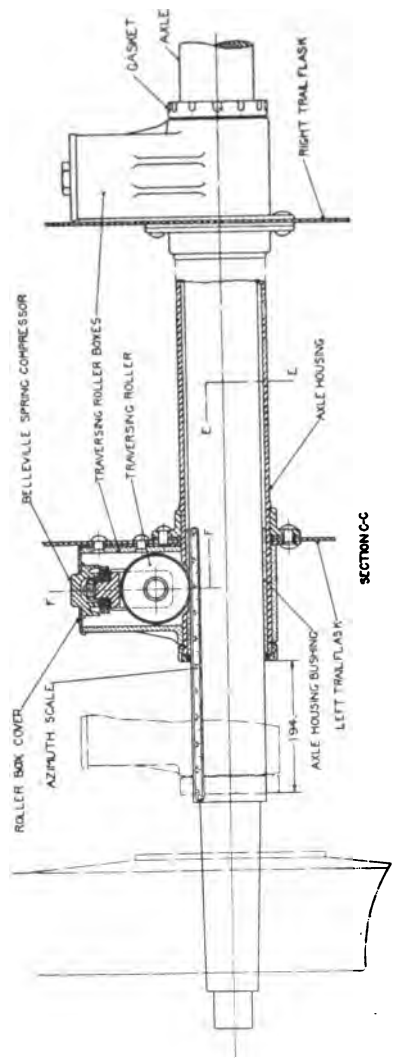

**SECTION C-C**

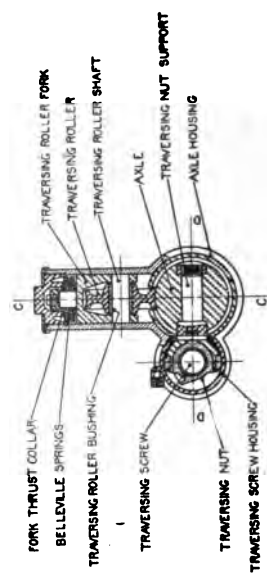

**SECTION F-F**

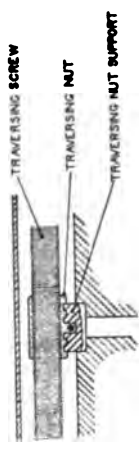

**SECTION D-D**

**155 MM HOWITZER, MODEL OF 1918 SCHNEIDER  
TRAVERSING ROLLERS**

0	20	40	60	80	100	120	140	160	180	200	220	240	260	280	300	320	340	360	380	400	420	440	460	480	500	520	540	560	580	600
---	----	----	----	----	-----	-----	-----	-----	-----	-----	-----	-----	-----	-----	-----	-----	-----	-----	-----	-----	-----	-----	-----	-----	-----	-----	-----	-----	-----	-----

CLASS 358 DIVISION 3 DRAWING 69

**THE SHIELD.**

(Plates XIII, XV, and XVI.)

The carriage is equipped with an armor plate shield, suitably reinforced by horizontal and vertical stiffeners. The shield consists of two plates riveted together on its vertical center line with butt straps. Above the opening for the howitzer, on the inner side, is riveted the shield hood encircling the opening, which protects the gunners from shrapnel and flying fragments when firing at low elevation.

The shield is bolted to brackets secured to the upper part of trail flasks and to lower brake-shaft bearing supports, which are riveted to the front of the trail flasks. The left side of the shield is provided with a sight port fitted with a hinged cover, which is held in closed position by means of a spring catch and open by means of a wing nut operated from behind the shield.

The panoramic sight case is supported through a system of springs by the sight-case bracket and is screwed to the inside of the shield in the upper left-hand corner. The case is a steel box in which the panoramic sight is locked and carried when the carriage is traveling.

**ROAD BRAKE.**

(Plates I-A, I-B, XV, and XVI.)

The carriage is provided with a road brake which is forced to bear against the tires of the wheels by means of a brake handle fitted to the brake screw on the outside of the shield. To ends of the brake shaft located just back of the shield are keyed brake arms fitted with brake heads to which shoes are riveted. When brake is applied these shoes bear directly on the rubber tires of the wheels. When the carriage is in traveling position it is essential for a man to dismount and walk beside the vehicle in order to operate the road brake when necessary.

## TOOLS AND ACCESSORIES.

A complete list of tools and accessories is given under "List of equipment pertaining to 155 mm. howitzer regiment" on page 161 of this book. Battery mechanics are directed to use only the tools provided by the Ordnance Department in making all repairs and necessary adjustments. Mechanics and others are cautioned against using tools or accessories for any purposes other than those for which they are intended. When tools and accessories are not in use they should be stored in their proper place or receptacle provided for same.

### AIR PUMP.

(Plate XXVII.)

The air pump is furnished for the purpose of charging and maintaining the necessary pressure in the counter recoil reservoirs. When in operation it is attached to a bracket on the carriage by means of a screw clamp and connected to the reservoir by the filling pipe. The pump will operate against a pressure of 400 to 600 pounds per square inch.

Power is applied by means of a hand lever connected by parallel links and a cross beam to the upper end of the piston operating through a gland in the top of the cylinder. The piston is fitted with a special packing at its lower end and operates in a cylinder larger in diameter than the body of the piston.

The action of the pump is as follows: As the piston moves up air is drawn through the intake valve filling the space below the piston. As the piston moves down the intake valve closes and the air is forced through the piston valve into the space around the piston and above the shoulder. This constitutes the first stage of compression. On the up stroke of the piston the air is forced out through the check valve into the counter-recoil system, constituting the second stage of the compression. At the same time more air is taken in through the intake valve.

The filling pipe connection should be covered with the provided connection cap when pump is not in use. The pump should be kept free from dust and grit and all parts should be well oiled. Loss of compression may be caused by small particles of dust on the valve seats preventing the valves from closing.

An assembling sleeve is furnished with the air pump which should be slipped into the top of the cylinder before inserting the piston. The piston should never be assembled without this sleeve as the sharp edge of the cylinder counterbore will probably ruin the packing. When operating the air pump for a long period a few drops of oil should be squirted in from time to time through the intake valve by turning the pump upside down. If the pump becomes too hot it will undoubtedly burn the piston packing and score the cylinder.

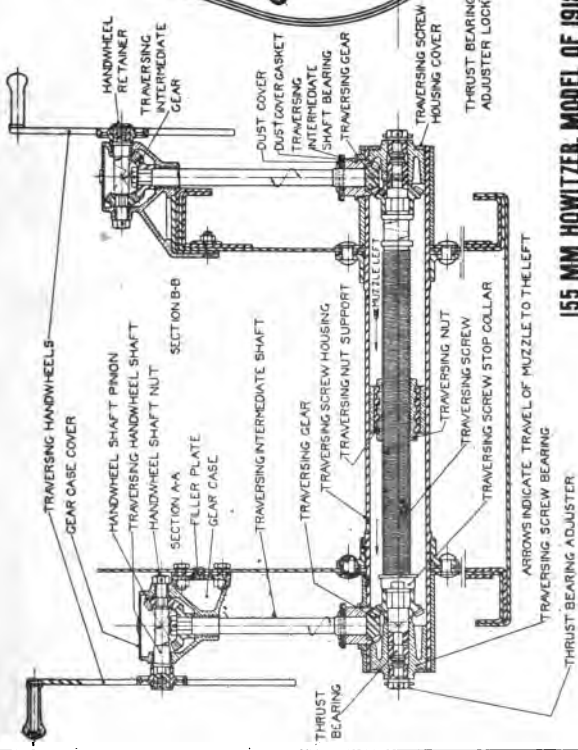
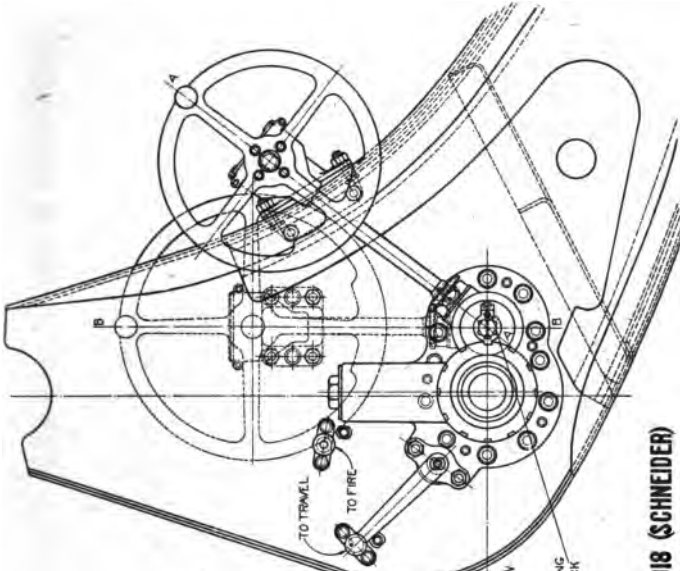

155 MM HOWITZER, MODEL OF 1918 (SCHNEIDER)  
TRAVERSING MECHANISM

0 25 50 100 150 200 250 300 350 400 450 500 549 550 MILLIMETERS

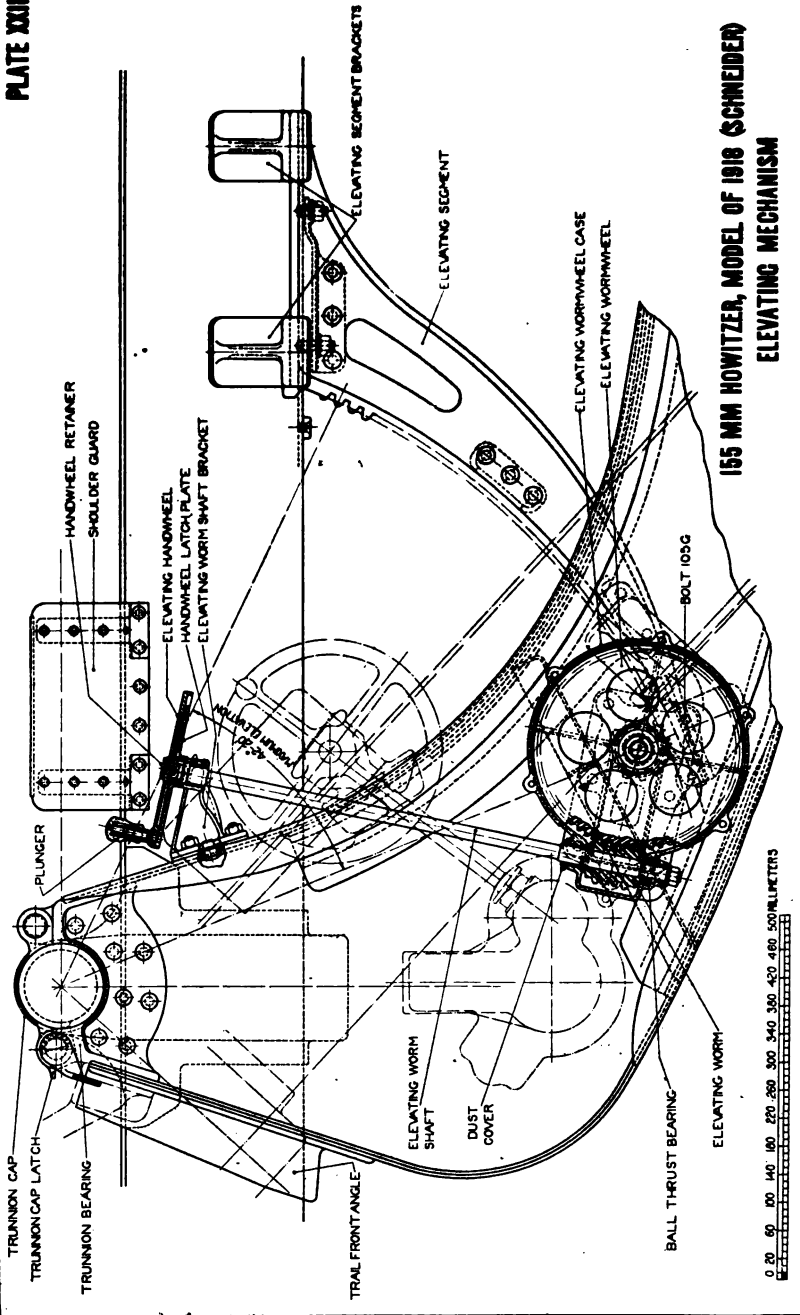

155 MM HOWITZER, MODEL OF 1918 (SCHNEIDER)  
ELEVATING MECHANISM

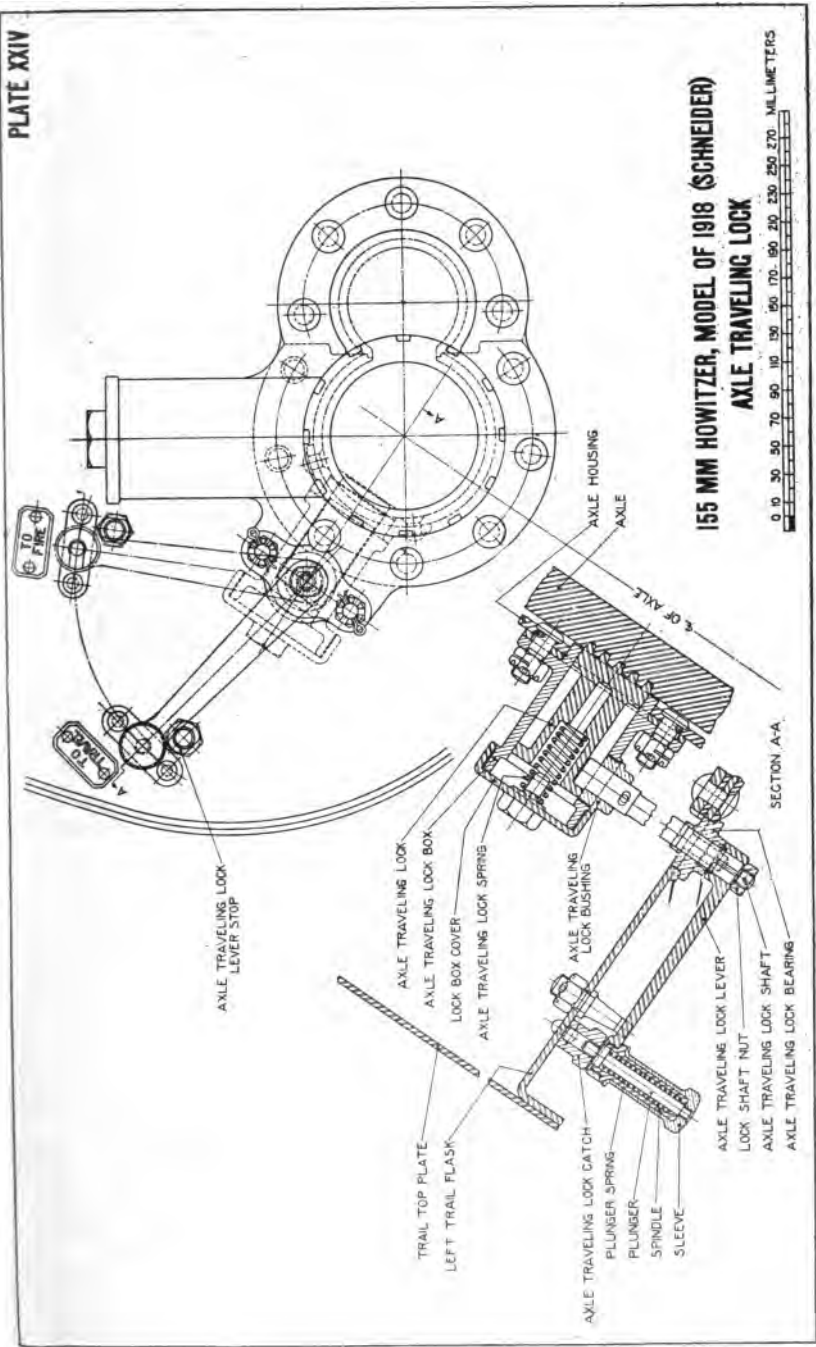

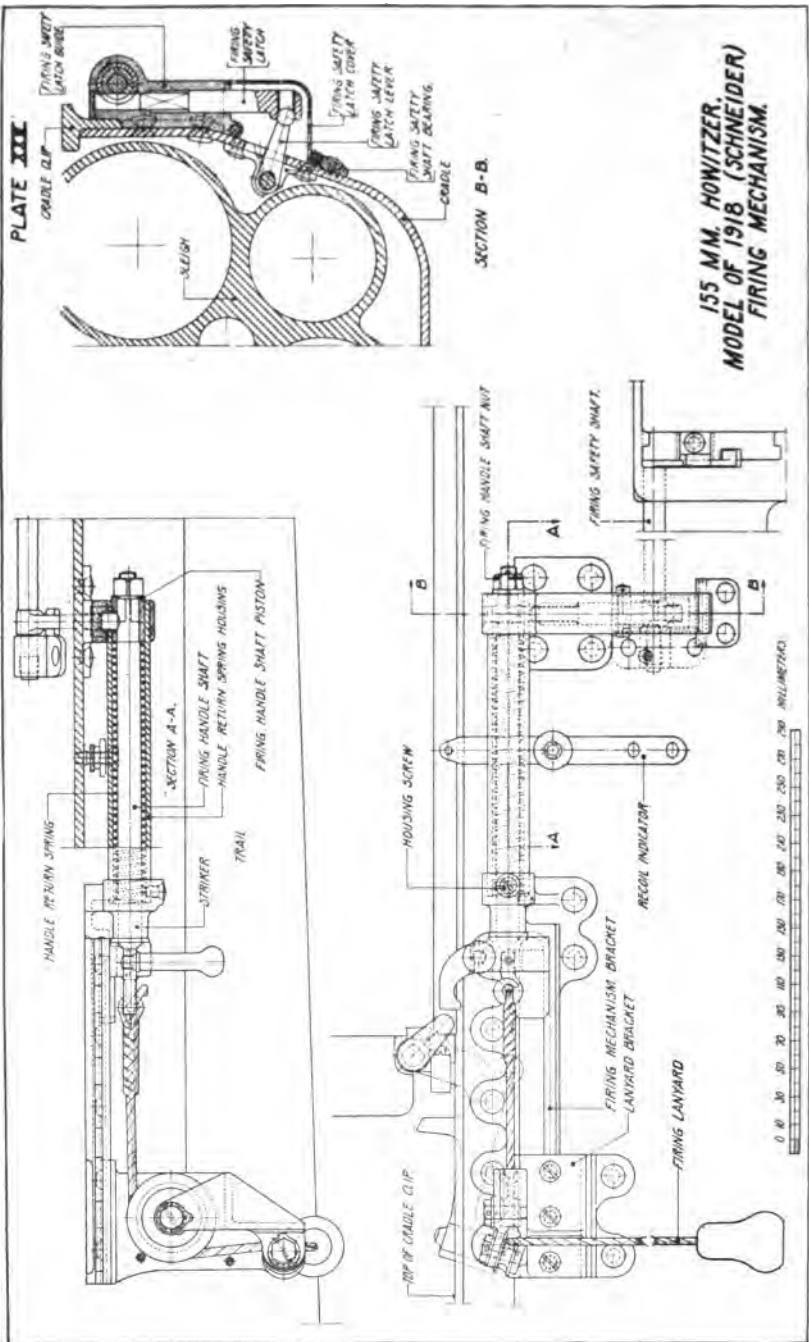

**LIQUID PUMP.**

(Plate XXVII.)

The liquid pump is a single-acting-plunger pump used for charging the counter-recoil system and for the purpose of replenishing losses of liquid from the cylinders. Power is applied through a hand lever connected by parallel links and a crossbeam at the lower end of the piston. The hand lever is detachable and also used in connection with the air pump. When in operation the pump is attached to a bracket on the carriage by means of a screw clamp. The filling pipe is employed to connect the liquid pump with the recuperator cylinder shown on Plate XXIV.

On the downward stroke of the piston liquid is drawn into the cylinder through a check valve from a 5 liters (approximately 5 quarts) reservoir containing a fine mesh strainer and located on top on the pump. On the up stroke it is discharged through a check valve through the filling pipe thence to the recuperator reservoir. On the suction stroke the check valve closes by action of the valve spring and the pressure in the counter-recoil system. Thus it is a single-acting force pump and will operate against a pressure of 600 pounds per square inch. The pumps should at all times be kept free from dust and grit also all parts should be well oiled. Loss of compression may be caused by small particles of dust on the valve seats preventing the valves from closing.

**RESERVOIR FOR COMPRESSED GAS.**

The reservoir for compressed gas is a commercial seamless cylinder with a capacity of 2,842 cubic inches and is charged with nitrogen gas at a working pressure of 2,000 pounds per square inch (140 kilograms per square centimeter). The reservoir is provided with a needle valve and a connection for the pressure gage or filling pipe. This cylinder is used for charging the counter-recoil system and may be carried on the artillery supply truck furnished with 155 mm. organizations. When the counter-recoil system is entirely empty or when a large amount of gas is to be added, nitrogen should be used in preference to air as it contains no oxidizing elements. The cylinders are plainly marked "Charged with nitrogen 2,000 lbs. per sq. in." Battery mechanics are cautioned against using cylinders which are not so marked.

**PRESSURE GAGE ADAPTER.**

The pressure gage adapter is composed of a bronze body with a steel valve stem and when in action is attached by a nut to the valve body in the left-hand reservoir head; has a connection for the gage and also a blow-off valve for adjusting the amount of gas in the reservoir.

## THE FILLING PIPES.

(Plate XXVI.)

The filling pipe is used to connect the counter-recoil reservoirs with the air or liquid pump or with the compressed gas reservoir. It consists of a flexible metallic hose of special construction to each end of which are brazed brass couplings. A check valve is provided in one coupling which is screwed into the valve body on the sleigh by means of an adapter or swivel.

The filling pipe is designed for a working pressure of 2,000 pounds per square inch, but care must be taken not to put sharp bends in it as this may cause it to leak. The connections at each end should never be removed from the pipe; however, the short swivel nut may be unscrewed to permit inspection of the check valve.

The filling pipe consists of a flexible bronze hose 1,800 millimeters in length, lined with two layers of rubber tubing and covered with galvanized steel braiding. The inner hose couplings are brazed to the hose. The pressure passes around the knurled end of the sleeve into the outer hose coupling and acting upon the outer surface of the tubing keeps the joints tight. Each outer hose coupling is provided with a swivel nut held in place by the swivel wire. One hose coupling is marked "reservoir" while the other is stamped "sleigh." The coupling marked "sleigh" is provided with a check valve which is acted upon by a check-valve spring and held in place by a valve follower.

The filling pipe also includes an adapter for connection to the sleigh, consisting of the swivel nut, swivel, gasket, and nipple. It is important that the coupling marked "sleigh" should be attached to the sleigh and the coupling marked "reservoir" to the reservoir or air pump. For convenience a rigid brass filling pipe is provided for use with the liquid pump only. This is so shaped that it fits between the discharge of the liquid pump and the long swivel of the filling pipe adapter without adjustment.

## PRESSURE GAGE.

The gage for the compressed gas reservoir is calibrated from 0 to 150 kilograms per square centimeter. It is used to ascertain the pressure of gas in the reservoir and must be attached before screwing on the filling pipe, Plate XXVI. The gage for the pressure-gage adapter is calibrated from 0 to 60 kilograms per square centimeter is screwed into the side of the adapter and used to test the pressure in the counter-recoil system.

It is essential that these gages be occasionally tested and calibrated. The mobile repair shop unit is provided with a gage-testin instrument for this purpose.

**LOADING BARROW.**

(Plates XIII and XIV.)

The loading barrow consists of a concave sheet-metal tray rounded with the same radius as the shell, so that the latter will be in correct alignment for loading. The tray is provided with two handles on each side, a support at the front end, and a truss at the rear end. When the gun is to be loaded the shell is laid on the tray, the handles then grasped by two men and the nose of the tray introduced into the breech of the howitzer. Here it is held by the lower smooth sectors of the breech threads, the rear end resting on the sleigh and the projectile stops, preventing the shell from sliding back and falling. The loading rammer is then used to ram the shell into the breech. When in traveling position the barrow and rammer are attached to the trail.

**WHEEL MATS.**

The wheel mats attached to the carriage are of woven rattan and wire reinforced with steel end plates and are 750 millimeters wide by 1,500 millimeters long. They are laid on the ground to form a support for the wheels when maneuvering the carriage on soft and swampy soil. When in transport the mats are carried in the wheel mat brackets secured on the underside of the trail.

**DRAG ROPE.**

The drag rope is a three-quarter-inch diameter manila rope approximately 117 inches long, with a hook and thimble spliced at one end. A sliding sleeve is provided to protect the rope from chafing on sharp edges of the wheels or trail. The other end of the rope is securely stitched to webbing belt, enabling man power to be used to move the carriage during emergency. The drag rope should be attached to a draft hook secured on the underside of trail or ring holes on the axle caps provided for general maneuvering purposes, such as pulling carriage out of mud or shell holes and when stuck in soft or swampy ground. By hooking the rope to the bottom spoke of the wheel and passing it around the circumference of the tire in the direction of rotation a wheel purchase is formed. When not in use it should be placed in the drag-rope pouch and secured to side of trail in receptacle provided for same.

**FUNNEL, MEASURE, AND FUNNEL PIPES.**

The funnel is used in connection with the curved funnel pipe for filling the recoil cylinder with the proper solution. It must not be used for any other purpose and should always be cleaned before using. The funnel fits into the upper end of the copper funnel pipe,

the lower end of which is inserted in filling hole of cylinders. The galvanized-iron measure, cylindrical in form, is provided with a handle having a brass strip graduated in half deciliters and used to measure the liquid.

#### SPONGE, STAFF, AND SLUSH BRUSH.

(Plates XIII and XIV.)

The sponge head is a cylindrical, built-up maple block covered with carpet which fits the bore of the howitzer and is secured to end of a metallic staff used for a handle. The staff consists of two iron pipes about 43 inches in length connected by male and female couplings. At each end of staff is attached a male coupling, enabling the sponge head, rammer head, or slush brush to be connected for use. The sponge is used to wash out the bore of the howitzer with the proper soda and water solution, and when covered with burlap it may be used to apply or remove slushing oil. When not in use it should be covered with the sponge cover and secured to left side of trail in receptacle provided for it. The slush brush consists of a carpet sponge of closely woven pile or nap, rigidly fastened to a hickory staff, and is used to coat the rifling grooves of the howitzer with grease during fire; also to apply slushing oil when necessary.

#### RAMMER.

The rammer head is composed of a cylindrical bronze body, which is a loose fit in the bore of the howitzer. It is fastened to the end of a metallic staff the same as used in connection with the sponge and slush brush. A recess is cut in the front end of the rammer head to receive the nose and fuze of the shell. The rammer is used to remove the shell from the bore when for any reason it is desired not to fire it immediately. To do this, insert the rammer in the muzzle end and with a gentle pat loosen the shell, taking care not to harm the fuze.

#### SIGHTING STAFF.

Sighting staff is composed of a wooden rod and telescopes into a piece of tubing, the slide ring clamping the tube to the rod and a steel point on the end of the tube permits the staff to be stuck in the ground. The sighting staff is used as an indirect aiming point for the panoramic sight.

#### RETRACTING ROPE AND TACKLE BLOCK.

The tackle block and retracting rope are used for bringing the howitzer into battery and traveling position. When preparing for action the hook of the rope is hooked to fastening on the trail and swivel hook of tackle secured to the lifting eye on the counterweight. When force is applied the howitzer is drawn into battery position.

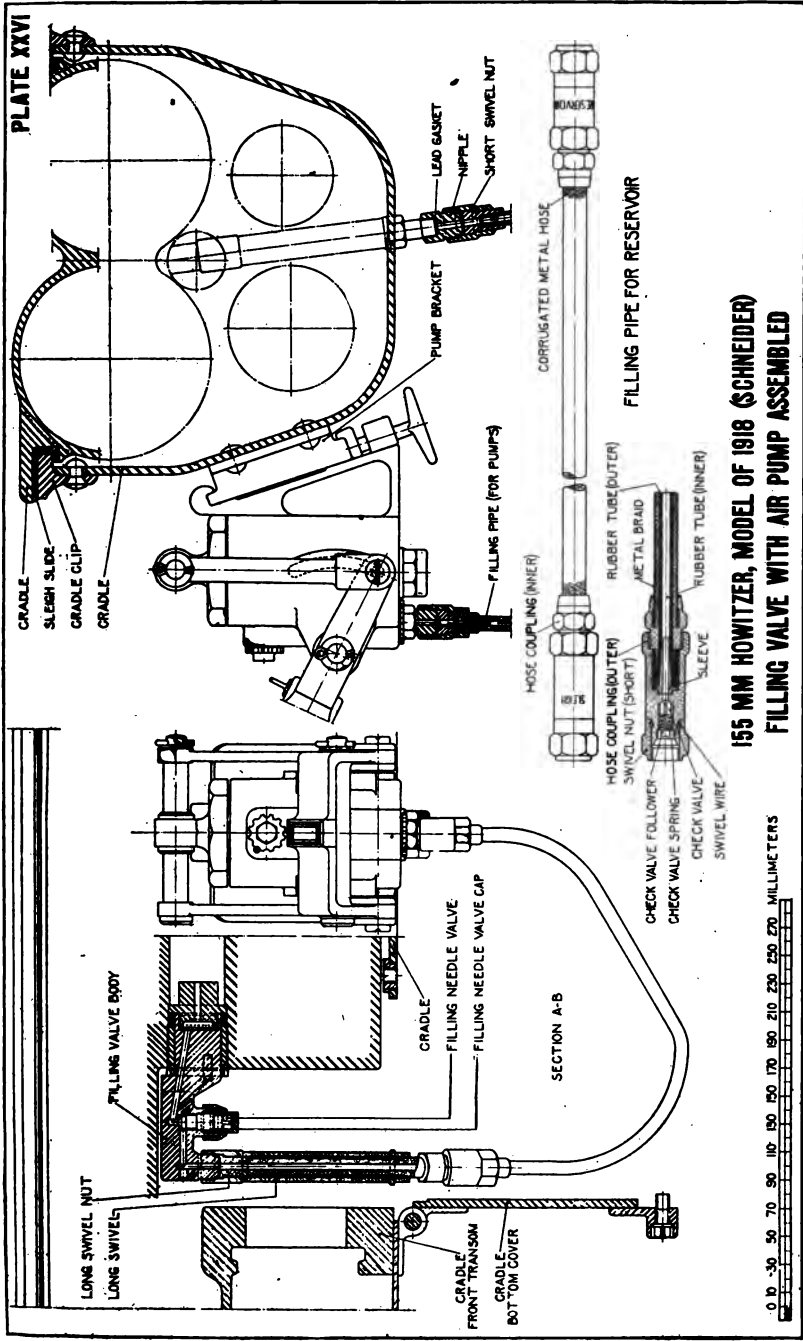

**155 MM HOWITZER, MODEL OF 1918 (SCHNEIDER)  
FILLING VALVE WITH AIR PUMP ASSEMBLED**

0 10 20 30 40 50 60 70 80 90 100 110 120 130 140 150 160 170 180 190 200 210 220 230 240 250 260 270 MILLIMETERS

**PLATE XXVII**

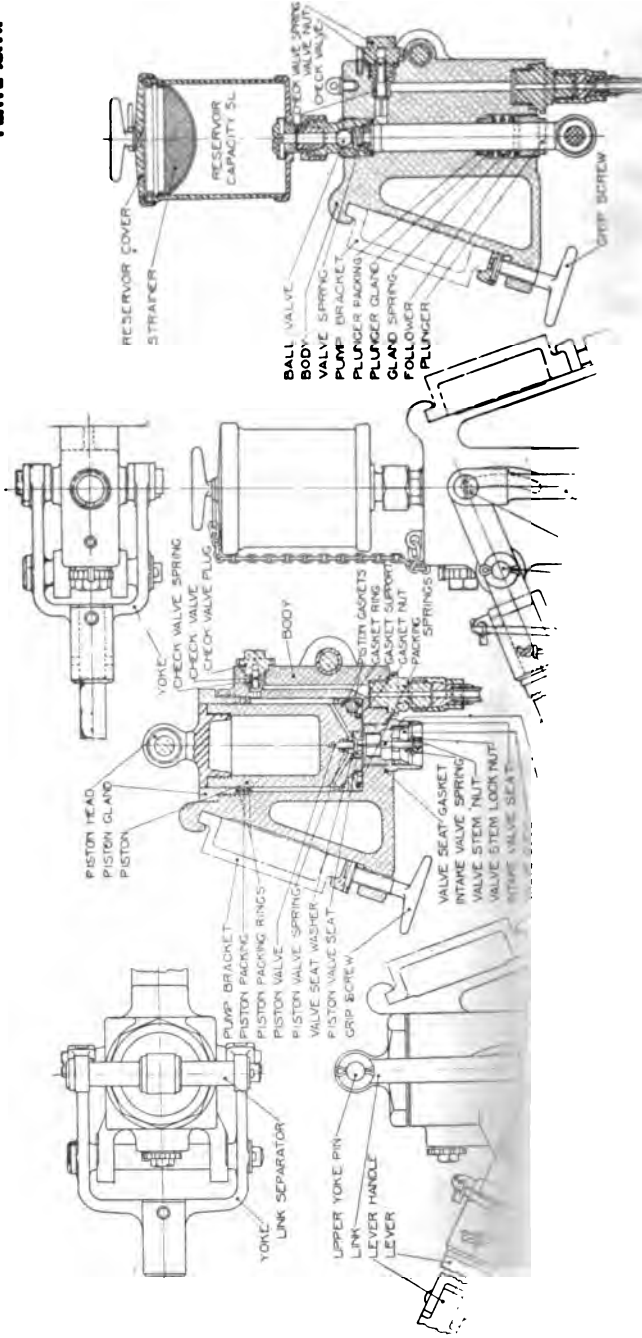

When preparing for travel, the swivel hook of tackle is secured to either lifting eye of counterweight and retracting rope hook fastened to either right or left eyebolt on back of shield, and in like manner the howitzer is brought into traveling position, then held by means of the traveling-lock mechanism.

### SIGHTS.

The following sighting equipment is carried with the 155-mm. howitzer matériel, model of 1918 (Schneider):

Quadrant sight, model of 1918 (Schneider).

Panoramic sight, model of 1917.

Peep sight.

Sight extension.

Gunner's quadrant, model of 1918.

Night lighting equipment.

#### THE QUADRANT SIGHT, MODEL OF 1918 (SCHNEIDER).

(Plate XXVIII.)

The quadrant sight, model of 1918 (Schneider), is mounted on the left trunnion of the carriage, both in traveling and in action, and should not be removed by the battery mechanics. The principal features of the quadrant sight are: The cross-leveling mechanism, the elevating mechanism, and the angle of sight mechanism.

*The cross-leveling mechanism* principally consists of the leveling worm, leveling stop, antibacklash spring, leveling clamp, and cross levels. By means of the cross-leveling mechanism the sight is brought level transversely when the mount proper is out of level. This insures that azimuth readings and settings will be made in the true horizontal plane.

The bracket fits into the trunnion on the left side of the carriage and is provided with four tenons which engage slots in the face of the trunnions keeping the sight in proper alignment with the bore of the howitzer. The bracket is screwed in place by bracket bolt; the front end of the body of the quadrant sight fits into the cylindrical part of the bracket and is held in place longitudinally by four lugs.

The body of the sight is rotated by the leveling worm engaging the worm wheel segment cut on the under side of the body. The outer end of the worm is provided with a knurled handwheel by means of which the leveling mechanism is operated. The leveling stop, secured to bracket, engages slot in the body, thus limiting the angular motion of the body in either direction. The rear end of the cylindrical part of the bracket is split and provided with a leveling clamp by means of which the body may be locked in position after it has been leveled.

The cross level is located on the rear edge of the sight shank and serves the gunner in determining the level position of the instrument. The level vial is a glass tube, closed at both ends, and partially filled with a liquid consisting of 40 per cent alcohol and 60 per cent ether, a small bubble remaining in the tube. Graduations are etched on the circumference of the tube to indicate the central position of the bubble. The vial is held in a level-vial tube, the ends being wrapped in paper and set in plaster of Paris. The knurled cross-level cover fits over the holder and, together with the level-vial tube, are held in place by the cross-level caps, which close the ends of the holder. When closed, the cover serves as a protection for the vial.

*The elevating mechanism* consists principally of a sight shank, elevating worm wheel, antibacklash pinion, elevating worm, elevating-worm eccentric, elevating scale drum, and scale-drum housing.

The sight shank is a curved bar, the upper end of which is provided with a T slot for receiving the shank of the panoramic sight. The lower curved part of the shank is formed into an annular rack, passing through the body, held in place by the body cover. The shank slides in the body of the quadrant sight and is actuated by a pinion cut on the hub of the elevating worm wheel, its motion being limited by a dowel, secured to hub of worm wheel. To the elevating worm wheel is attached the scale drum graduated in mils of elevation, which is read at an index line through a window in the drum housing.

The eccentric stop limits the angular motion of the elevating eccentric. By turning the eccentric spring case in a clockwise direction, as seen from the front end of the sight, the elevating worm eccentric can be rotated approximately  $120^\circ$ , throwing the elevating worm out of mesh with the worm wheel. The sight can then be rapidly adjusted for approximate range setting. When the eccentric spring case is released, the eccentric returns the worm to its former position in mesh with the worm wheel. The exact range setting is obtained by rotating the knurled handwheel secured to worm shaft operating the elevating worm wheel.

*The angle of site mechanism* is attached to sight shank just above the rack, and consists of a worm housing, sight pointer, sight worm, pointer spindle, micrometer drums, and levels.

The angle of site worm housing is riveted to the left side of the sight shank just above the rack and forms a bearing for the sight pointer on back of which a worm wheel is cut. The tension of a helical torsion spring tends to turn the pointer in a clockwise direction and keep the teeth of worm housing against the worm, eliminating backlash. The sight pointer spindle, operating in the spindle bearing, causes the pointer to move along a scale engraved on the top of the housing. This scale is graduated in equal divisions, each repre-

senting 100 mils. The figure 3 (300 mils) is the dead level position. The front micrometer drum slips over the drum bearing grooved in such a manner that when the front drum clamp is screwed into it, the former expands inside of the micrometer drum, thus holding the drum in place. The rear micrometer drum is slipped over the worm, being held in place by friction, and is graduated in mils from zero to 100, every tenth division being numbered.

The elevation level vial and vial tube are similar in all respects to the cross vial and tube. The tube is mounted in the level holder and prevented from turning by the small lug on the rear end of the tube. The level holder rests in bearings on the sight pointer and the ends of holder are closed by caps to prevent entrance of dust.

*Key to Plate XXVIII (quadrant sight).*

Illustration No.	Nomenclature.	Illustration No.	Nomenclature.
1	Bracket for 155 mm. howitzer carriage, model of 1918 (Schneider).	31	Alignment spring compressor.
2	Bracket for 155 mm. gun carriage, model of 1918 (Filloux).	32	Antibacklash pinion shaft.
3	Bracket bolt.	33	Pinion shaft spring.
4	Body.	34	Pinion shaft nut.
5	Leveling worm.	35	Elevating worm bearing.
6	Leveling worm washer.	36	Elevating handwheel.
7	Leveling worm nut.	37	Elevating worm bushing.
8	Leveling stop.	38	Elevating worm plunger.
9	Antibacklash spring.	39	Elevating worm spring.
10	Spring adjuster.	40	Elevating eccentric bearing.
11	Bracket cap.	41	Eccentric stop.
12	Spring adjuster lock screw.	42	Eccentric spring case.
13	Leveling clamp.	43	Eccentric springs.
14	Leveling clamp nut.	44	Eccentric spring guide.
15	Cross level holder.	45	Elevating scale.
16	Cross level holder screw.	46	Angle of site worm housing.
17	Cross level vial.	47	Angle of site pointer.
18	Cross level caps.	48	Outer clearance spring.
19	Sight shank.	49	Angle of site pointer spindle.
20	Antibacklash pinion.	50	Clearance spring guide.
21	Elevating worm wheel.	51	Pointer spindle bearing.
22	Elevating scale drum.	52	Inner clearance spring.
23	Elevating worm.	53	Angle of site worm.
24	Elevating eccentric.	54	Angle of site worm spring.
25	Scale drum housing.	55	Angle of site worm spring washer.
26	Clamp screw.	56	Micrometer drum (front).
27	Ratchet.	57	Micrometer drum bearing.
28	Body cover.	58	Micrometer drum clamp (front).
29	Alignment thimble.	59	Micrometer drum (rear).
30	Alignment spring.	60	Micrometer drum clamp (rear).
		61	Elevation level vial.
		62	Elevation level cap.

**THE PANORAMIC SIGHT, MODEL OF 1917.**

(PLATE XXIX.)

The panoramic sight is a vertical telescope so fitted with an optical system of reflecting prisms and lenses that the gunner can bring into his field any point in a plane perpendicular to the axis of the telescope. The optical characteristics of the instruments are as follows:

Power = 4.

Field of view =  $10^{\circ}$ .

The rotating head prism (61) has a movement of 600 mils in a vertical plane; movement is obtained by turning elevation micrometer (66). The amount and direction of rotation is indicated on a scale (26) in the head (60) by the elevation index (29) and micrometer (66). The scale is graduated in 100-mil intervals, the micrometer in mils. One complete turn of the micrometer is equivalent to one space on the scale (26). The head is level when the index is opposite 3 and micrometer at zero.

Movement in azimuth is obtained by turning azimuth worm (56). The amount of rotation is read from the scale (37) on the azimuth circle (35) and the azimuth micrometer (52). The azimuth micrometer (52) may be turned independently of the azimuth worm (44) to set any desired deflection. Figures in black are for right-hand deflection and in red for left-hand deflection. The scale on the azimuth circle (35) is graduated in 100-mil divisions from 0 to 32 in each half circle. The micrometer is graduated for every mil. For larger angular deflections, by turning the throw-out lever (49) the azimuth worm (44) is disengaged, permitting the head to be turned to any desired position.

The reticule (22) is provided with a horizontal and a vertical crossline. The horizontal line is graduated in mils.

An open sight (48) attached to the side of the rotating head (60) is for approximate setting of the instrument.

A complete detailed description of panoramic sight, model of 1917, is contained in Handbook of Fire Control Equipment for Field Artillery—Pamphlet No. 1796.

Instructions for care and preservation of panoramic sight, model of 1917, are contained in pamphlet No. 1795.

No disassembling or adjustment of the panoramic sight, except as described herein, is to be made, except by ordnance personnel detailed for such work.

The panoramic sight is seated in a T slot in a socket of the quadrant sight, model of 1918 (Schneider), in firing, and is carried in a panoramic sight case on the shield when traveling.



PLATE XXIX.

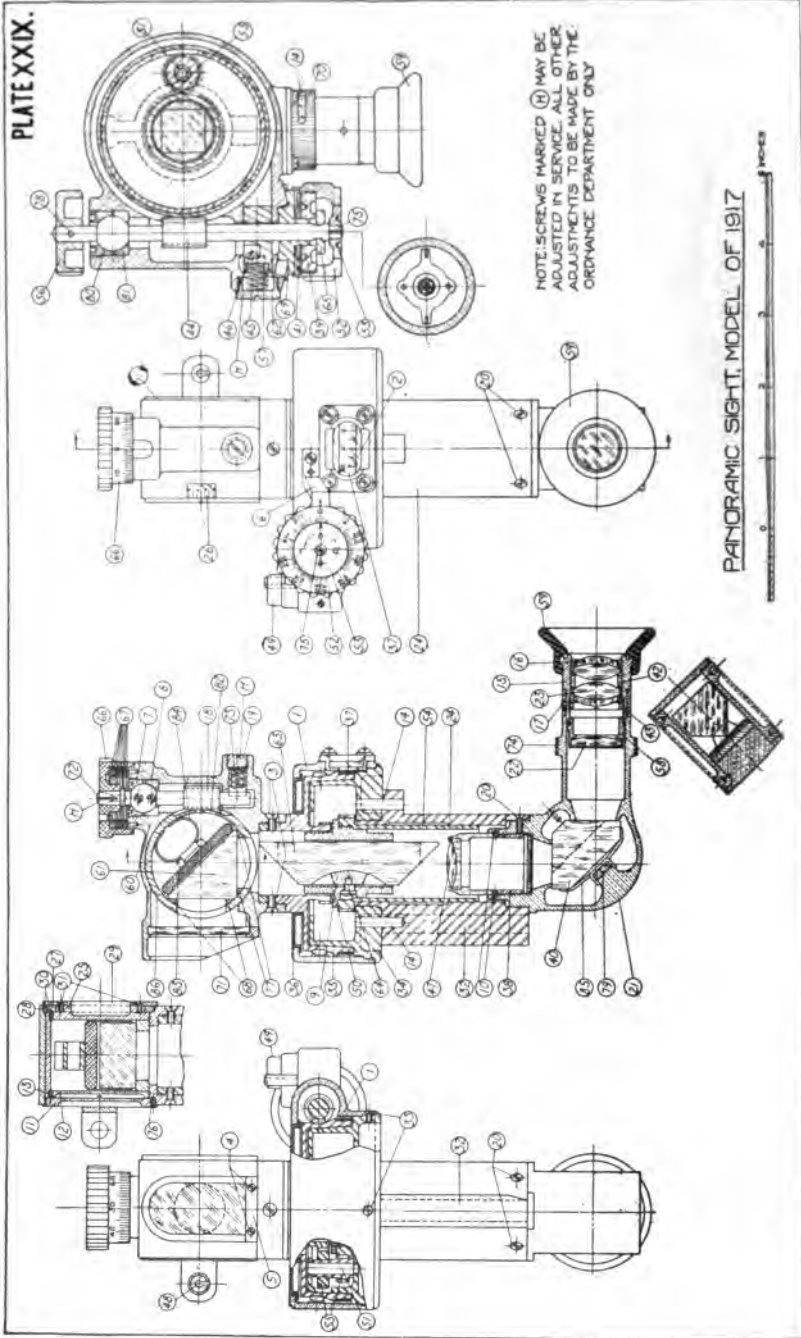

NOTE: SCREWS MARKED (14) MAY BE ADJUSTED IN SERVICE. ALL OTHER ADJUSTMENTS TO BE MADE BY THE ORDNANCE DEPARTMENT ONLY.

PANORAMIC SIGHT, MODEL OF 1917



## Key to Plate XXIX.

Illustration No.	Nomenclature.	Illustration No.	Nomenclature.
1	Azimuth circle hood.	45	Spring.
2	Window.	46	Throw out cam.
3	Rotating head retaining screw.	47	Achromatic objective lens.
4	Prism shield retaining piece screw.	48	Open sight.
5	Prism shield retaining piece.	49	Throw out lever.
6	Azimuth index.	50	Rotating prism holder.
7	Elevation worm-ball cap.	51	Pinion shaft
8	Elevation worm-ball socket.	52	Azimuth micrometer.
9	Block in rotating prism.	53	Micrometer index.
10	Objective lens cell-retaining screw.	54	Supporting sleeve for rotating prism.
11	Rotating head cover.	55	Pinions for rotating prisms and rotating head.
12	Prism holder cover.	56	Azimuth worm knob.
13	Prism holder cover screw.	57	Throw out plunger
14	Dowel pin for sight shank.	58	Reticule cell.
15	Eye lens cell.	59	Rubber eyepiece.
16	Achromatic eye lens.	60	Rotating head.
17	Eye lens cell retaining screw.	61	Rotating head prism.
18	Elevation worm.	62	Spring retaining nut.
19	Worm plunger spring plug.	63	Rotating prism.
20	Elbow retaining screw.	64	Rotating prism holder screw.
21	Elbow.	65	Retaining washer.
22	Reticule.	66	Elevation micrometer.
23	Achromatic field lens.	67	Stop ring.
24	Shank.	68	Prism support, front.
25	Elevation index support.	69	Index knob washer.
26	Nickel silver piece.	70	Window.
27	Support retaining ring.	71	Prism shield.
28	Support retaining ring screw.	72	Micrometer locking screw, short.
29	Elevation index.	73	Worm plunger spring.
30	Elevation index support screw.	74	Shutter.
31	Elevation index retaining screw.	75	Micrometer locking screw, long.
32	T lug.	76	Rotating head cover screw.
33	Azimuth circle hood screw.	77	Prism support, bottom.
34	Azimuth circle support.	78	Taper pin, $0.002(\frac{1}{16}) \times 0.5$ .
35	Azimuth circle.	79	Wedge.
36	Spring plate for azimuth circle.	80	Bearing cap.
37	Nickel silver strip.	81	Bearing socket.
38	Objective lens cell.	82	Rotating head prism holder.
39	Deflection locking plate.	83	Prism support, back.
40	Lower reflecting prism.	84	Rotating head prism spring.
41	Locking spring.	85	Lower reflecting prism holder
42	Field lens cell retaining ring.		
44	Azimuth worm.		

## USE OF PANORAMIC SIGHT.

(Plate XXIX.)

## FOR DIRECT FIRE.

Set index mark on angle of site pointer opposite 3 and micrometer at zero. Release clamp, and by rotating cross leveling worm, bring cross level bubble central, and then reclamp. On the panoramic sight set azimuth scale at zero, azimuth micrometer at zero, micrometer index at zero, elevation scale at 3, and elevation micrometer knob at zero

Correct for deflection in azimuth by first turning azimuth micrometer until required deflection is opposite fixed arrow pointer and then bring arrow on micrometer index to zero on azimuth micrometer by means of azimuth worm knob. Elevate the quadrant sight shank until the required reading is obtained on the elevation scale.

Elevate and traverse gun until cross hairs of panoramic sight are on target.

## FOR INDIRECT FIRE.

Cross level sight and set scales of azimuth micrometer and micrometer index on panoramic sight at zero and correct for deflection in azimuth as explained under "direct fire."

Set the azimuth circle of panoramic sight at the deflection ordered (the amount of this deflection is equal to the angle formed by the lines joining the sight to the target and to the indirect aiming point). Set the elevation scale on the quadrant sight to give the required range.

Set the angle of site pointer as ordered.

Elevate the howitzer until the elevation level bubble is central, and traverse until the vertical cross hair is on the indirect aiming point. The howitzer is now laid on the target.

The deflection angle and the angle of site are ordinarily given to the gunner from the fire-control station.

When the target is visible, these angles can be determined as follows:

*Deflection angle.*—Set azimuth scale at zero, azimuth micrometer zero at fixed arrow, and micrometer index at zero; and traverse gun until vertical cross hair is on the target. Then turn rotating head of panoramic sight until vertical cross hair is on the indirect aiming point. The deflection thus read from the azimuth scale and the azimuth micrometer is the deflection angle in mils.

*The angle of site.*—Set angle of site pointer at 3, and micrometer at zero, and bring elevation level bubble central by turning elevating handwheel. Then elevate or depress the upper prism of the panoramic sight until the horizontal cross hair is on the target. As the point 3 on the scale is zero elevation, all readings must be figured above or below this point. The reading thus figured is the angle of site in mils.

The open sight on side of rotating head is used to obtain preliminary direction of sight.

In turning azimuth angles greater than 100 mils, the throw-out lever may be pressed and rotating head turned to nearest division in even hundreds desired. Each unit on azimuth scale represents 100 mils.

A sighting staff is provided for use as in indirect aiming point in cases where a natural point is not available.

**THE PEEP SIGHT.**

The peep sight is an open sight consisting of a peep-sight support, cross wires, and an eyepiece or peep sight. The lower end of the support is fitted into a shank, which fits into the socket in the top of the quadrant-sight shank. The cross wires are mounted in the

cross-wire ring at 90° to each other and 45° to the horizontal. The cross-wire ring fits into the cross-wire holder and is held in place by the cross-wire retainer. The cross-wire holder is screwed with 32 threads per inch into the holder sleeve, and the latter is screwed with 30 threads per inch into the peep-sight support. These two pieces are prevented from turning by two split pins passing through the support at right angles to each other. The threads allow a vertical adjustment.

The peep-sight guide is riveted in place in the rear end of the support, its edges fitting into the T-slot in the bottom of the peep sight or eyepiece. A German-silver scale, graduated in equal divisions each representing 10 mils, fits into a groove in the rear end of the peep-sight guide. The scale is held in place by two screws, the holes in the scale being elongated to allow for adjustment. An index is marked on the back edge of the peep sight, and the latter may be traversed by means of the peep-sight screw. This screw is mounted in the support and held in place by a nut on the right-hand end and by the peep-sight-screw handle on the other. The handle is held in place by the handle-locking screw. A micrometer scale is engraved on the handle, graduated in half mils.

#### USE OF THE PEEP SIGHT.

The use of the peep sight is limited to direct fire only. The peep sight is mounted on the shank of the quadrant sight and is interchangeable with the panoramic sight.

Set the index mark on angle of site pointer opposite 3 and micrometer at zero. Release clamp and, by rotating leveling worm, bring cross level bubble central and then reclamp. On the peep sight turn the peep-sight screw until the required deflection is read from the deflection scale and from the graduations on the peep-sight screw handle. Elevate the quadrant sight shank until the required reading is obtained on the elevation scale.

Elevate and traverse gun until the crosswires of the peep sight are on the target.

#### THE SIGHT EXTENSION.

The sight extension is a steel bar, one end of which is fitted with a T-slot, clamp screw, ratchet, and detent similar to the upper end of the quadrant-sight shank. The lower end of the extension is shaped to fit into the quadrant-sight shank. The extension is used to raise the panoramic sight to a sufficient height to see over the shield or other part of the piece when necessary in directing aiming. When using the sight extension, the panoramic sight should be removed before firing.

**GUNNER'S QUADRANT, MODEL OF 1918.**

The gunner's quadrant, model of 1918, is a verticle angle-measuring instrument graduated in mils. The principal parts of the quadrant are the frame, index arm, sliding level, and index-arm head. It is used on all kinds of guns and howitzers, either to give the elevation directly or to verify the angles obtained by the sights.

The frame is of bronze, shaped in the form of an arc. The inside edge is furnished with teeth at 10-mil intervals. These teeth are graduated on one side of the frame from 0 to 800 mils, and on the opposite side of the frame from 800 to 1,600 mils.

The index arm is pivoted on the frame and is fitted with a sliding head holding a level vial. The index arm is slightly curved and is graduated in 0.2-mil intervals from 0 to 10 mils. Readings finer than 10 mils are read by means of the sliding head and index arm scale.

The index-arm head is mounted on and slides in the end of the index arm. The teeth on the index arm engage in those of the frame acting as a lock, permitting the adjustment of the index arm to 10-mil intervals. With the index arm and sliding level set at 0, the quadrant will read true horizontal with the bubble midway between the graduations on the vial.

With the index arm elevated, and by use of the sliding level with its scale, readings may be made to an accuracy of about plus or minus 0.2 mil.

Steel shoes are screwed to the frame on two of its sides to serve as bearing plates for the quadrant.

Each instrument is given a dull finish and is furnished with a leather carrying case, and is to be carried in the sight chest when not in use.

**USE OF THE GUNNER'S QUADRANT.**

To give any elevation less than 800 mils, as 761.6 mils: Place the edge of the index-arm head opposite the 760 mark of the graduated arc on the frame and slide the level along until its index is opposite the 1.6 mark of the scale on the index arm. The quadrant is now set to the required reading. Place the quadrant on the leveling plates on the breech end of the howitzer with the words "Line of fire" at the bottom and the arrow pointing to the muzzle. Elevate the howitzer until the level bubble comes to rest at the center. This will be the elevation required.

To give any elevation greater than 800 mils, as 1,483.2, the scales on the reverse side of the quadrant and index arm are used. Place the edge of the index-arm head opposite the 1,480 mark of the graduated arc on the frame and slide the level along until its index is opposite the 3.2 mark of the scale on the index arm. Place the quadrant on the leveling plates with the words "Line of fire" at the bottom and the

arrow pointing to the muzzle and elevate until the level bubble is central. This will be the required elevation.

To give any depression, proceed as before, but turn the quadrant end for end so that the arrow will point toward the breech. See that the frame shoes and leveling plates are free from dirt; otherwise incorrect readings will result. Care must be taken to use the index-arm scale which lies on the same side of the quadrant as the graduated arc to which the index arm is set.

#### **NIGHT LIGHTING EQUIPMENT.**

Two complete sets of lighting equipment are provided for use when firing at night. When not in use these equipments should be packed in cases provided for that purpose and carried on the carriage limber. The night lighting equipment consists principally of a chest, an aiming lamp, an azimuth lamp, a level lamp, a portable lamp, and the necessary cables and fixtures.

The night lighting equipment chest is a metal box lined with wood and is moisture proof, containing four dry cells with necessary connections, cables of various lengths, lamp brackets, socket plug, and cable details. The cells are connected in series parallel to a switch panel located at the side of the chest, giving approximately 3 volts effective at each of the four plug switches in the panel. When the carriage is in action the equipment chest is placed on the ground near the vehicle and the various lights connected by means of cables and connection plugs. When not in use the night lighting devices for sights should be properly packed in the case for lighting equipment.

The aiming lamp is a 6-volt electric lamp mounted in a holder and provided with a bracket which can be attached to an aiming post driven in the ground. Cable 150 feet in length is attached to the aiming lamp, the other end fitted with a plug for connecting the lamp to batteries. The aiming lamp is so shaped that the light is only visible from one direction. When in use the lamp forms an illuminated indirect aiming point and can not be seen by the enemy. When not in use the aiming lamp cable with lamp and plug attached should be wound on the reel provided for that purpose packed in the case for lighting equipment.

The azimuth lamp is a 6-volt electric lamp mounted in the azimuth lamp holder; this holder is attached by means of the azimuth lamp holder bracket to the body of the panoramic sight. The holder is so shaped that the light is deflected through two tubes; one illuminating the azimuth scale azimuth micrometer of the panoramic sight, and the other illuminating the cross hairs in the reticule of the panoramic sight through the window in the eyepiece.

The level lamp is a 6-volt electric lamp mounted in the leveling lamp holder. The holder is held in vertical position by means of the level lamp holder bracket which is attached to the body of the panoramic sight. The light is so shaded that it shines directly on the angle of the site scale, the elevation level, and elevation scale of the quadrant sight.

The portable lamp is a 6-volt electric lamp mounted in the portable lamp holder. This holder is provided with a hook so it may be hung on any convenient part of the sight or carriage. It is used as a hand lamp for illuminating any desired part of the sight or carriage or for illuminating the scales on the hand fuse setter.

The azimuth lamp, level lamp, and portable lamp are each provided with a cable, 3 meters long, and fitted at the other end with a plug for connecting them with the battery box. When not in use these cables with the lamp and plugs attached should be wound on the spools provided for that purpose and properly packed in the case for lighting equipment.

## THE 155 MM. HOWITZER CARRIAGE LIMBER, MODEL OF 1918 (SCHNEIDER).

### WEIGHTS AND PRINCIPAL DIMENSIONS.

Weight of limbers completely equipped.....	662 kg.=1,436.5 lb.
Weight of limber and 155 mm. howitzer, model of 1918 (Schneider), limbered.....	4,015.6 kg.=8,926.5 lb.
Weight on ground under each wheel, with carriage limbered.....	628 kg.=1,378 lb.
Weight of limber empty.....	557.7 kg.=1,227 lb.
Weight of each wheel.....	104.3 kg.= 335 lb.
Diameter of wheels.....	1,240 mm.= 42.82 in.
Width of track.....	1,550 mm.= 61 in.
Turning angle with 155 mm. howitzer, model of 1918 (Schneider), limbered.....	52°.

NOTE.—The weight of this carriage limber equipped with horse pole is practically the same as the caisson equipped with motor pole.

### NOMENCLATURE OF THE LIMBER.

(Property Classification—Class IV, Division 3.)

The battery personnel is directed to use the following nomenclature, giving piece marks and drawing numbers, when referring to parts of the limber in reports, correspondence, etc.:

Number.	Name of part.	Piece mark.	Drawing.		
			Class.	Division.	Number.
1	Axle.....	14A.....	3	44	14
	Including—				
1	Axle nut.....	14B.....	3	44	14
	Including—				
1	Nut lock screw.....	14C.....	3	44	14
2	Pins (8 by 97 mm., riveted).....				
2	Pins (8 by 102 mm., riveted).....				
4	Pins (8 by 116 mm., riveted).....				
1	Connecting pole body.....	LB22A.....	15	2KL	22
	Including—				
1	Connecting pole hinge.....	LB21A.....	15	2KL	21
1	Lunette.....	LB9A.....	15	2KA	9
1	Lunette bearing.....	LB10C.....	15	2KL	10
2	Lunette pins.....	LB10D.....	15	2KL	10
	Including—				
2	Split pins (0.25 by 1.25 inches).....		30	2	1
1	Connecting pole hinge plate.....	LB22B.....	15	2KL	22
	Including—				
1	Hinge pin.....	LB21B.....	15	2KL	21
	Including—				
1	Hinge pin nut.....	LB21C.....	15	2KL	21
1	Split pin (0.203 by 2 inches).....		30	2	1
1	Frame, complete, consisting of—				
2	Axle brackets.....	14D.....	3	44	14
1	Box holder band.....	17B.....	3	44	17
1	Box holder bracket (front).....	17A.....	3	44	17
1	Box holder bracket (rear).....	17E.....	3	44	17
1	Box holder bracket (side).....	17D.....	3	44	17
1	Box holder collar.....	17C.....	3	44	17
1	Box holder yoke (longitudinal).....	18A.....	3	44	18
1	Box holder yoke (transverse).....	18B.....	3	44	18
1	Bucket holder.....	10E.....	3	44	10
	Including—				
1	Bucket holder support.....	10F.....	3	44	10
1	Bucket holder support brace.....	10G.....	3	44	10
1	Strap fastener No. 15.....	NB1R.....	15	2KN	1
1	Case transverse support (left).....	20A.....	3	44	20
1	Case transverse support (right).....	20F.....	3	44	20
2	Doubletree chain eyes.....	10II.....	3	44	10
1	Filler plate.....	17F.....	3	44	17

Num- ber.	Name of part.	Piece mark.	Drawing.		
			Class.	Divi- sion.	Num- ber.
	Frame, complete, consisting of—Continued.				
1	Front rail (left).....	10D.....	3	44	10
1	Front rail (right).....	10C.....	3	44	10
1	Grease box cover.....	19A.....	3	44	19
	Including—				
1	Cover packing.....	19B.....	3	44	19
1	Lock bar.....	19C.....	3	44	19
1	Lock bar eye pin.....	19H.....	3	44	19
	Including—				
1	Lock bar pin handle.....	19K.....	3	44	19
1	Pin (2 by 12 mm., driven).....				
1	Lock bar eye.....	19F.....	3	44	19
1	Lock bar eye bearing.....	19G.....	3	44	19
1	Lock bar hinge.....	19D.....	3	44	19
1	Lock bar hinge pin.....	19E.....	3	44	19
1	Longitudinal support (inner left).....	20E.....	3	44	19
1	Longitudinal support (inner right).....	20G.....	3	44	20
1	Longitudinal support (outer left).....	20B.....	3	44	20
1	Longitudinal support (outer right).....	20H.....	3	44	20
2	Longitudinal support tie bars.....	20D.....	3	44	20
1	Middle rail (left).....	7B.....	3	44	7
1	Middle rail (right).....	7A.....	3	44	7
1	Middle rail bottom plate.....	8B.....	3	44	8
1	Middle rail collar.....	21A.....	3	44	21
1	Middle rail reinforce.....	9A.....	3	44	9
1	Middle rail top plate.....	8A.....	3	44	8
1	Middle rail transom (front).....	10B.....	3	44	10
1	Middle rail transom (rear).....	10A.....	3	44	10
1	Name plate.....	24D.....	3	44	24
1	Picket rope hook (left).....	16C.....	3	44	16
1	Picket rope hook (right).....	16B.....	3	44	16
1	Picket rope support.....	16A.....	3	44	16
1	Pintle.....	12A.....	3	44	12
	Including—				
1	Pintle yoke.....	12B.....	3	44	12
1	Pintle yoke rivet.....	12C.....	3	44	12
1	Pintle filler plate.....	13A.....	3	44	13
1	Prop chain.....	15C.....	3	44	15
	Including—				
1	Prop chain eye.....	15D.....	3	44	15
	Including—				
1	Nut, crown (8 mm.).....	Q17DA.....	30	2	17
1	Split pin (0.093 by 1 inch).....		30	2	1
1	Prop chain handle.....	15B.....	3	44	15
1	Prop carrying ring.....	15E.....	3	44	15
1	Safety chain fastening.....	22F.....	3	44	22
	Including—				
1	Safety chain.....	24B.....	3	44	24
1	Safety chain cross bar.....	24A.....	3	44	24
1	Safety chain fastening filler plate.....	22G.....	3	44	22
1	Side rail (left).....	11B.....	3	44	11
1	Side rail (right).....	11A.....	3	44	11
2	Support auxiliary brackets.....	20C.....	3	44	20
8	Swing bolt hinges.....	KB77H.....	15	2KK	77
	Including—				
8	Hinge rivets (A=0.9 inch).....	KB77L.....	15	2KK	77
8	Swing bolts.....	KB77F.....	15	2KK	77
	Including—				
8	Wing nuts.....	KB77G.....	15	2KK	77
1	Trail rest.....	13B.....	3	44	13
1	Prop tube.....	15A.....	3	44	15
	Including—				
1	Prop eye.....	15G.....	3	44	15
1	Prop foot.....	15F.....	3	44	15
1	Pole supporting mechanism, complete, consisting of—				
1	Collar disc.....	21D.....	3	44	21
4	Collar disc bolts.....	22E.....	3	44	22
	Including—				
4	Nuts, crown (18 mm.).....	Q17KA.....	30	2	17
4	Split pins (0.156 by 1.5 inches).....		30	2	1
1	Pole supporting spring.....	22A.....	3	44	22
1	Pole supporting spring bolt.....	21B.....	3	44	21
	Including—				
1	Split pin (0.25 by 3 inches).....		30	2	1
1	Spring bolt nut.....	21C.....	3	44	21
1	Spring bolt sleeve.....	22B.....	3	44	22
1	Spring plate (front).....	22D.....	3	44	22
1	Spring plate (rear).....	22C.....	3	44	22

Num-ber.	Name of part.	Piece mark.	Drawing.		
			Class.	Divi-sion.	Num-ber.
2	Wheels, complete, consisting of—				
2	Axle caps.....	PB46A.....	15	2KP	46
2	Axle collars.....	PB47G.....	15	2KP	47
2	Base bands.....	PB44F.....	15	2KP	44
2	Dust collars.....	PB46H.....	15	2KP	46
14	Carriage bolts.....	PB47D.....	15	2KP	47
	Including—				
14	Carriage bolt nuts.....	PB47H.....	15	2KP	47
4	Felloes (long).....	PB44C.....	15	2KP	44
4	Felloes (short).....	PB44D.....	15	2KP	44
2	Felloe bands.....	PB44G.....	15	2KP	44
2	Hub boxes.....	PB45D.....	15	2KP	45
	Including—				
2	Grease plugs.....	PB45G.....	15	2KP	45
	Including—				
2	Grease plug thongs.....	PB45K.....	15	2KP	45
2	Thong eye bolts.....	PB45H.....	15	2KP	45
2	Hub liners (inner).....	PB45B.....	15	2KP	45
2	Hub liners (outer).....	PB45C.....	15	2KP	45
2	Hub liners crews (A=8 mm.).....	PB45E.....	15	2KP	45
2	Hub liner screws (A=10 mm.).....	PB45F.....	15	2KP	45
2	Hub rings.....	PB45A.....	15	2KP	45
2	Linch pins.....	PB46D.....	15	2KP	46
	Including—				
2	Linch pin fids.....	PB46F.....	15	2KP	46
2	Linch pin latches.....	PB46G.....	15	2KP	46
2	Linch pin latch rivets.....	PB46E.....	15	2KP	46
14	Spokes (left).....	PB44B.....	15	2KP	44
14	Spokes (right).....	PB44A.....	15	2KP	44
28	Spoke shoes.....	PB47A.....	15	2KP	47
28	Spoke shoe plates.....	PB47C.....	15	2KP	47
28	Spoke shoe rivets.....	PB47E.....	15	2KP	47
2	Tires.....	PB44E.....	15	2KP	44
16	Tire bolts.....	PB47E.....	15	2KP	47
	Including—				
16	Tire bolt nuts.....	PB47L.....	15	2KP	47
16	Tire bolt washers.....	PB47K.....	15	2KP	47
2	Washers (inner).....	PB46B.....	15	2KP	46
2	Washers (outer).....	PB46C.....	15	2KP	46

### DESCRIPTION OF THE LIMBER.

(Plates XIV, XXX, and XXXI.)

The 155 mm. howitzer carriage limber, model 1918 (Schneider), is a two-wheeled vehicle used to support the trail of the carriage when traveling.

### THE FRAME.

The frame is built of two-flanged steel middle rails, and the top and bottom plates, riveted together to form a box section. The axle brackets or collars are riveted to the middle rails on either side of the frame. The axle is held in position laterally by a shoulder on the axle, against which the outer edge of the left axle bracket bears, and by the axle nut which screws on the axle and bears against the outer edge of the right axle bracket. The axle is prevented from turning by rivets which are driven through each axle bracket. The pintle is riveted to the extreme rear end of the frame, and serves as a bearing for the lunette of the carriage when the howitzer is limbered. The trail rest is riveted to the top plate of the frame in front of the pintle and forms a bearing for the fifth

wheel of the carriage when the howitzer is limbered. The two front rails are riveted to the front end of the frame and extend across the front of the limber. The extreme outside ends of the front rails are riveted to the side rails, which extend back and fit over the axle just inside the axle collars. The picket rope hooks are riveted to the inside of the side rails near the axle. The doubletree chain eyes are riveted on the front ends of the side rails. The picket rope support is riveted to the underside of the middle rails near the rear end.

The case transverse supports are riveted in place extending between the side rails and the middle rails. The longitudinal supports are riveted in place extending between the case transverse supports and the front rails. The longitudinal supports are tied together at their front ends by the longitudinal support tie bars which are connected to the front rails by the support auxiliary brackets. These members, when assembled, form two supports for the cases for lighting equipment which are bolted to them.

The grease box holder is located between the frame and right longitudinal case support just back of the front rail. It consists of a transverse and longitudinal box holder yoke, the top ends of which are riveted to the box holder collar. The latter is riveted to the frame and the front rail. The yokes are held rigid by the box holder band which passes around them about halfway down. The grease box holder is fitted with a cover, lock bar, hinge and catch, the cover being lined with wood.

The bucket holder is attached to the bucket holder support which is riveted to the front of the right front rail and stiffened by the bucket support brace. The buckets are held in place by a leather strap secured to top of bucket holder support and top edge of bucket holder.

The limber prop is fitted with a prop eye at its upper end and the lower end with the prop foot. When not in transport the limber prop serves to support the front end of the limber. When traveling the limber prop is turned up under the left front rail and held in place by the prop chain, the eye of which is attached to the underside of the left front rail.

The name plate, giving the number of the limber, model, name of manufacturer and initials of the inspector, is located on the top of the frame near the front end. In all reports and correspondence the limbers should be designated by the number and model given on the name plate.

The safety chain is attached to the safety chain fastening which is riveted to the top plate just in front of the trail rest. The safety chain cross bar should be passed through the safety chain ring on

PLATE XXX

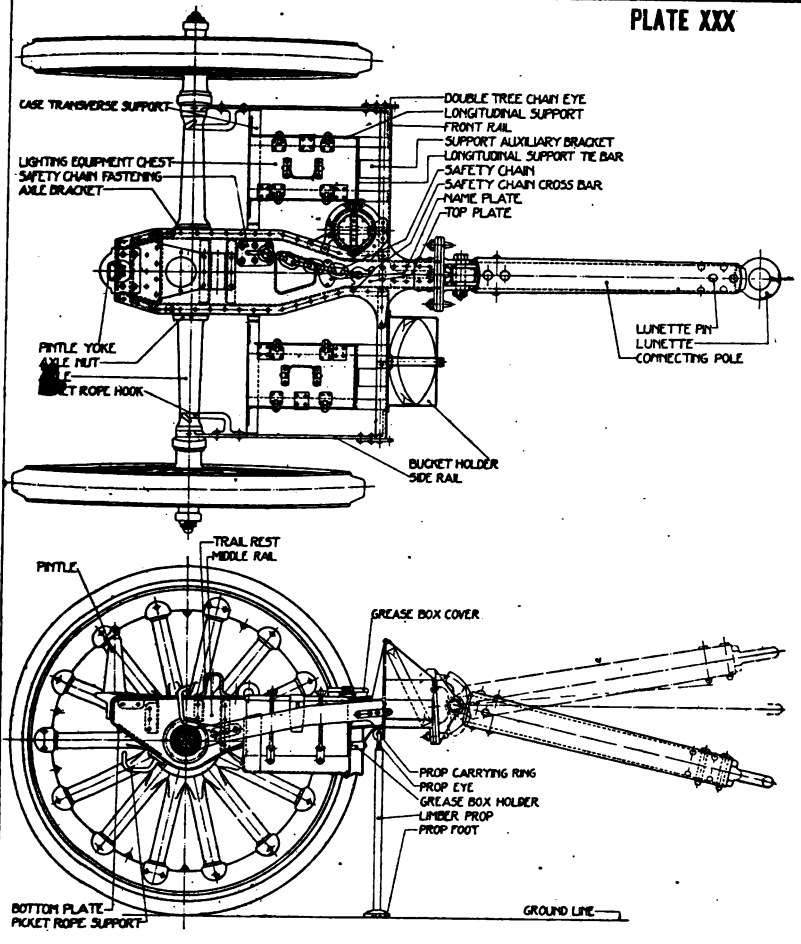

155 MM. HOWITZER CARRIAGE LIMBER.  
 MODEL OF 1918 (SCHNEIDER).  
 PLAN AND RIGHT SIDE VIEWS

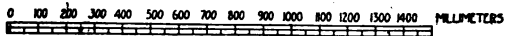
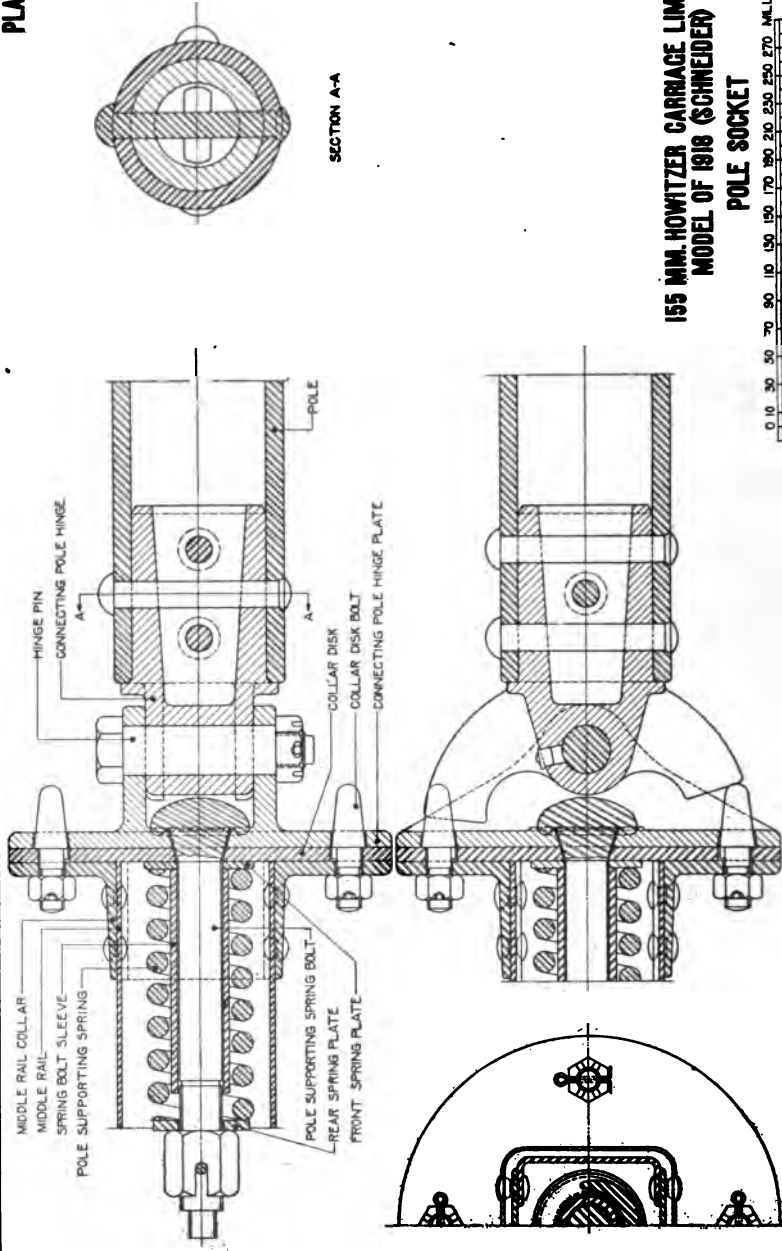

PLATE XXX



155 MM. HOWITZER CARRIAGE LIMBER  
MODEL OF 1918 (SCHNEIDER)  
POLE SOCKET

the trail of the carriage after the howitzer has been limbered. The chain prevents the grinding of the tires against the wheel guards of the carriage.

#### THE POLE SOCKET AND POLE.

(Plate XXXI.)

The middle rail collar is riveted to the extreme front end of the frame. The pole supporting spring bolt passes through the center of the hinge plate, collar disk, and front spring plate and extends through the spring bolt sleeve inside of the pole-supporting spring. The rear end is fitted with a rear spring plate and crown nut which keeps the spring in compression, bearing against the front and rear spring plates.

The hinge pin passes through the eyes of the hinge plate and the connecting pole hinge, which is forced and riveted into the rear end of the connecting pole. The connecting pole hinge is so shaped that the pole is allowed to rock through an angle of 35° in a vertical direction. The lunette bearing is riveted in the front end of the pole. The lunette passes through this bearing and is held in place by the lunette pins.

The limber is so designed that it can be transformed into a horse-drawn vehicle by removing the connecting pole and connecting pole hinge plate and substituting the horse pole, pole socket, double-tree and singletree.

#### WHEELS.

The wheels are of wooden construction, 1,240 mm. in diameter and rubber tired. The spokes are mounted between the hub box and the hub rings and held in place by carriage bolts. The hub box is lined with the outer and inner hub liners which bear on the axle. An oil hole is provided through the hub box and inner hub liner for supplying grease to the bearing surfaces. The inner end of the inner hub liner bears on a leather washer which is placed inside of the dust collar. The dust collar fits over the axle collar and both bear against the side rails of the limber. The hub is held on the axle by the axle cap, a leather washer being placed under the cap to prevent lateral motion of the wheel. The linchpin passes through the axle cap and axle, holding the former in place. The outer ends of the spokes fit into the spoke shoes, which are riveted to the felloe. The felloe band is shrunk around the felloe and held with tire bolts. The base band on which the rubber tire is mounted is shrunk on the felloe band.

**THE 155-MM. HOWITZER CAISSON, MODEL OF 1918  
(SCHNEIDER).**

**WEIGHTS AND PRINCIPAL DIMENSIONS.**

Weight of one caisson without equipment unloaded.....	1,065	kg.	=2,345 lbs.
Weight of tools and accessories.....	46.3	kg.	= 102 lbs.
Weight of caisson completely equipped, unloaded.....	1,102	kg.	=2,447 lbs.
Weight of 8 powder containers.....	20	kg.	= 44 lbs.
Weight of powder carried.....	58.2	kg.	= 128 lbs.
Weight of shells carried.....	605	kg.	=1,330 lbs.
Weight of caisson completely equipped and loaded.....	1,793	kg.	=3,949 lbs.
Weight behind tractor, two caissons completely equipped and loaded.....	3,586	kg.	=7,898 lbs.
Weight on ground under each wheel of rear vehicle, equipped and limbered, unloaded.....	549	kg.	=1,197 lbs.
Weight on ground under each wheel of front vehicle, equipped and limbered, unloaded.....	574	kg.	=1,261 lbs.
Weight on ground under each wheel of rear vehicle, equipped and limbered, loaded.....	8,866	kg.	=1,930 lbs.
Weight on ground under each wheel of front vehicle, equipped and limbered, loaded.....	911	kg.	=2,004 lbs.
Weight of reel caisson completely equipped and unloaded..	1,140	kg.	=2,504 lbs.
Weight of reel caisson completely equipped and loaded....	1,822	kg.	=4,006 lbs.
Over-all length of two caissons.....	4,730	mm.	= 186 in.
Width of track.....	1,530	mm.	= 60 in.
Diameter of wheels.....	1,530	mm.	= 60 in.
Turning diameter of two caissons.....	5.5	m.	= 18 ft.

NOTE.—The weight of the caisson equipped with horse pole is practically the same as the caisson equipped with motor pole.

**NOMENCLATURE OF THE CAISSON.**

Property Classification.—(Class IV, Division 3.)

The battery personnel is directed to use the following nomenclature, giving piece marks and drawing numbers when referring to parts of the caisson in reports, correspondence, etc.:

Num-ber.	Name of part.	Piece mark.	Drawing.		
			Class.	Divi-sion.	Num-ber.
1	Apron, complete, consisting of—				
1	Apron.....	12D.....	13	53	12
4	Apron hinges (male).....	GBIF.....	15	2KG	1
2	Door handle bars.....	MB2Q.....	15	2KM	2
	Including—				
4	Door handle bases.....	MB2F.....	15	2KM	2
2	Wing nuts.....	JB1Q.....	15	2KJ	1
2	Wing nut pins.....	JB1M.....	15	2KJ	1
2	Wing nut pin washers.....	JB1R.....	15	2KJ	1
1	Axle.....	PB2C.....	15	2KP	2
	Axle brackets, complete, consisting of—				
2	Axle brackets.....	16A.....	3	53	16
4	Axle bracket bushings.....	16C.....	3	53	16
	Including—				
8	Pins, bronze (driven).....				
2	Band clips.....	BB28E.....	15	2KB	28

Num-ber.	Name of part.	Piece mark.	Drawing.		
			Class.	Divi-sion.	Num-ber.
	Axle brackets, complete, consisting of—Continued.				
2	Brake hanger brackets.....	BB27A.....	15	2KB	27
	Including—				
2	Lock washers (0.75 inch).....	Q6PC.....	30	2	6
2	Nuts, plain (0.75 by 0.625 inch).....	BB27F.....	15	2KB	27
4	Screws (0.75 by 7.625 inches, flat filister head).....	BB27E.....	15	2KB	27
	Including—				
4	Nuts, crown (0.75-inch).....	Q6ZA.....	30	2	6
4	Split pins (0.156 by 1.5 inches).....		30	2	1
1	Brake mechanism, complete, consisting of—				
2	Brake bands.....	BB28B.....	15	2KB	28
	Including—				
2	Band guides.....	BB28D.....	15	2KB	28
2	Brake band linings.....	BB28C.....	15	2KB	28
2	Brake hangers.....	BB27B.....	15	2KB	27
2	Brake hanger bracket braces.....	BB27G.....	15	2KB	27
1	Brake lever.....	BB29E.....	15	2KB	29
	Including—				
1	Brake lever bearing.....	BB30A.....	15	2KB	30
1	Brake lever catch.....	BB10H.....	15	2KB	10
1	Brake lever hook.....	BB7G.....	15	2KB	7
1	Brake lever bracket.....	BB30B.....	15	2KB	30
	Including—				
1	Brake lever pin.....	BB30D.....	15	2KB	30
	Including—				
1	Brake lever pin washer.....	BB29B.....	15	2KB	29
1	Nuts, crown (0.75 inch).....	Q6ZA.....	30	2	6
1	Pin (0.187 by 1.875 inches).....				
1	Split pin (0.156 by 1.5 inches).....		30	2	1
4	Lock washers (0.375 inch).....	Q6HC.....	30	2	6
4	Nuts (0.375 inch).....	Q6SA.....	30	2	6
4	Screws (0.375 by 1.25 inches, countersunk head).....	BB30C.....	15	2KB	30
1	Brake lever rod.....	BB31E.....	15	2KB	31
	Including—				
1	Brake rod end.....	BB31G.....	15	2KB	31
2	Brake rods.....	BB31C.....	15	2KB	31
	Including—				
2	Brake rod ends.....	BB31G.....	15	2KB	31
2	Brake rod levers.....	BB25D.....	15	2KB	25
1	Brake shaft.....	BB30F.....	15	2KB	30
	Including—				
1	Split pin (0.25 by 1 inch).....		30	2	1
1	Brake shaft crank.....	BB30H.....	15	2KB	30
2	Nuts, crown (0.75 by 0.625 inch thick).....	BB27F.....	15	2KB	27
6	Pins, type A (0.610 by 1.875 inches, A—1.281 inches).....	BB31D.....	15	2KB	31
	Including—				
12	Split pins (0.156 by 1 inch).....		30	2	1
4	Pins, type A (0.734 by 2.5 inches, A—1.656 inches).....	BB27D.....	15	2KB	27
	Including—				
8	Split pins (0.203 by 1.25 inches).....		30	2	1
2	Pins, type U (0.866 by 3.125 inches, A—1.562 inches).....	BB27C.....	15	2KB	27
	Including—				
4	Split pins (0.203 by 1 inch).....		30	2	1
2	Pins, type D (0.610 by 3.125 inches, A—1.875 inches, B—0.625 inch).....	BB25E.....	15	2KB	25
	Including—				
4	Split pins (0.156 by 1 inch).....		30	2	1
1	Caisson prop, complete, consisting of—				
2	Prop eyes.....	LB15A.....	15	2KL	15
1	Prop foot.....	LB15D.....	15	2KL	15
2	Prop tubes.....	LB15C.....	15	2KL	15
1	Chest, complete, consisting of—				
2	Apron hinges (female).....	GB1E.....	15	2KB	1
2	Apron latches (female).....	14L.....	3	53	14
2	Apron latches (male).....	14M.....	3	53	14
1	*Ax pocket.....	HB16E.....	15	2KH	16
1	*Ax stop.....	HB52D.....	15	2KH	52
	Including—				
1	*Leather pad for ax stop.....	HB52E.....	15	2KH	52
7	Bolts (0.625 by 12.812 inches).....	9H.....	3	53	9
	Including—				
7	Nuts, crown (0.625 inch).....	Q6XA.....	30	2	6
7	Split pins (0.156 by 1.5 inches).....		30	2	1
7	Washers (0.625 inch).....	Q6DE.....	30	2	6
1	Brake lever bracket reinforce.....	B32H.....	15	2KB	32
1	Brake shaft bracket (left).....	24B.....	3	53	24
	Including—				
1	Handy oiler (0.5 inch).....	Q2K.....	30	2	2

\* Not required for caisson equipped with reel, model of 1917.

Num-ber.	Name of part.	Piece mark.	Drawing.		
			Class.	Divi-sion.	Num-ber.
	Chest, complete, consisting of—Continued.				
1	Brake shaft bracket (right).....	24A.....	3	53	24
	Including—				
1	Handy oiler (0.5 inch).....	Q2K.....	30	2	2
1	Brake shaft bracket reinforce (left).....	BB32G.....	15	2KB	32
1	Brake shaft bracket reinforce (right).....	BB32F.....	15	2KB	32
1	Brace support (left).....	24D.....	3	53	24
1	Brace support (right).....	24C.....	3	53	24
1	Bucket holder body.....	HB9K.....	15	2KH	9
	Including—				
1	Strap fastener, style No. 10.....	NB1L.....	15	2KN	1
8	Carrier tubes.....	11A.....	3	53	11
1	Chest angle (front).....	22A.....	3	53	22
1	Chest angle (rear).....	22E.....	3	53	22
1	Chest body (lower).....	19A.....	3	53	19
1	*Chest body (upper).....	21A.....	3	53	21
1	†Chest body (upper).....	27A.....	3	53	27
1	Chest stiffener angle.....	22B.....	3	53	22
1	Chest stop (left).....	17F.....	3	52	17
1	Chest stop (right).....	17E.....	3	53	17
2	Diaphragm separators (A=11.625 inches).....	9E.....	3	53	9
6	Diaphragm separators (A=6.625 inches).....	9F.....	3	53	9
5	Diaphragm separators (A=4.812 inches).....	9G.....	3	53	9
1	Diaphragm stop (upper).....	10N.....	3	53	10
4	Door hinges (female) (lower door).....	GB5B.....	15	2KG	5
4	Door hinges (female) (upper door).....	GB5A.....	15	2KG	5
8	Door hinge rivets.....	GBIX.....	15	2KG	1
1	Door prop guide (left).....	MB9B.....	15	2KM	9
1	Door prop guide (right).....	MB9A.....	15	2KM	9
1	Filler plate (left).....	24F.....	3	53	24
1	Filler plate (right).....	24E.....	3	53	24
1	Front diaphragm (lower).....	9B.....	3	53	9
1	Front diaphragm (upper).....	9A.....	3	53	9
1	Fuze box stop.....	18L.....	3	53	18
1	Fuze box support (left).....	18F.....	3	53	18
1	Fuze box support (right).....	18E.....	3	53	18
1	Guide bracket (front) (left).....	17B.....	3	53	17
1	Guide bracket (front) (right).....	17A.....	3	53	17
1	Guide bracket (rear) (left).....	17D.....	3	53	17
1	Guide bracket (rear) (right).....	17C.....	3	53	17
2	Handrails.....	MB2G.....	15	2KM	2
	Including—				
4	Handrail shanks.....	MB2B.....	15	2KM	2
4	Handrail shank fillers.....	MB2T.....	15	2KM	2
2	‡Implement fastenings, complete, consisting of (1 for ax, 1 for hatchet)—				
2	†Fastening bases.....	HB44A.....	15	2KH	44
2	†Fastening levers.....	HB17D.....	15	2KH	17
2	†Fastening lever pins.....	HB17M.....	15	2KH	17
2	†Fastening lever pins.....	HB17P.....	15	2KH	17
2	†Fastening springs.....	HB44C.....	15	2KH	44
2	†Spring fillers (hatchet) (left).....	HB44K.....	15	2KH	44
1	Implement fastening, complete, consisting of (for wrench)—				
1	Fastening base.....	HB44A.....	15	2KH	44
1	Fastening lever.....	HB17D.....	15	2KH	17
1	Fastening lever pin.....	HB17M.....	15	2KH	17
1	Fastening lever pin.....	HB17P.....	15	2KH	17
1	Fastening spring.....	HB44C.....	15	2KH	44
1	Spring filler (wrench).....	HB44E.....	15	2KH	44
1	Intermediate plate (lower).....	20B.....	3	53	20
1	Intermediate plate (upper).....	20A.....	3	53	20
1	Lantern bracket complete, consisting of—				
1	Lantern bracket body.....	HBIB.....	15	2KH	1
1	Lantern bracket bottom.....	HBIA.....	15	2KH	1
2	Lantern strap fasteners.....	HBIC.....	15	2KH	1
1	Lantern strap fastener.....	HBIC.....	15	2KH	1
1	Lock bar bearing (left).....	14B.....	3	53	14
1	Lock bar bearing (right).....	14A.....	3	53	14
1	Locking lever bearing (left).....	14D.....	3	53	14
1	Locking lever bearing (right).....	14C.....	3	53	14
1	Loose diaphragm counter stop.....	20C.....	3	53	20
	Including—				
1	Chain.....	JB5A.....	15	2KJ	5
2	Chain rings.....	JB5M.....	15	2KJ	5
2	Chain rivets.....	JB5L.....	15	2KJ	5
1	Lunette bracket.....	HB52F.....	15	2KH	52
1	Middle diaphragm (lower).....	9C.....	3	53	9

\* Not required for caisson equipped with reel, model of 1917.

† Required for caisson equipped with reel, model of 1917 only.

‡ One only required for caisson equipped with reel, model of 1917.

Num-ber.	Name of part .	Piece mark.	Drawing.		
			Class.	Divi-sion.	Num-ber.
	Chest, complete, consisting of—Continued.				
1	Middle diaphragm (upper).....	8B.....	3	53	8
1	Name plate.....	13C.....	3	53	13
1	Oil can guide (left).....	18D.....	3	53	18
1	Oil can guide (right).....	18C.....	3	53	18
1	Oil can stop.....	18M.....	3	53	18
1	Oil can support (left).....	18B.....	3	53	18
1	Oil can support (right).....	18A.....	3	53	18
1	Pick handle rest.....	HB12D.....	15	2KH	12
1	Pick pocket.....	HB2H.....	15	2KH	2
1	Pick rest.....	HB12N.....	15	2KH	12
2	Pins, type A (0.368 by 1.76 inches).....	14Q.....	3	53	14
	Including—				
4	Split pins (1.25 by 0.75 inch).....		30	2	1
1	Pintle bearing support (lower).....	AB52C.....	15	2KA	52
1	Pintle bearing support (upper).....	AB52A.....	15	2KA	52
	Including—				
1	Pintle spring.....	AB3D.....	15	2KA	3
1	Pintle spring guide.....	AB3A.....	15	2KA	3
2	Tap bolts (0.375 by 1 inch).....	AB52D.....	15	2KA	52
1	Tap bolt (0.375 by 0.08 inch).....	AB52E.....	15	2KA	52
1	*Pole bracket (left).....	HB 52B.....	15	2KH	52
	Including—				
1	*Pin, type A (0.61 by 3.812 inches, A=3.187 inches).....	HB52C.....	15	2KH	52
	Including—				
2	*Split pins (0.156 by 1 inch).....		30	2	1
1	*Pole bracket (right).....	HB52A.....	15	2KH	52
14	Projectile tubes.....	13A.....	3	53	13
1	Rear diaphragm (lower).....	9D.....	3	53	9
1	Rear diaphragm (upper).....	8A.....	3	53	8
4	Rear plate.....	12C.....	3	53	12
1	Seat supports.....	13B.....	3	53	13
1	Segment rack.....	BB26F.....	15	2KB	26
	Including—				
1	Brake lever stop rivet.....	BB29C.....	15	2KB	29
1	Segment rack bracket.....	BB32E.....	15	2KB	32
1	Shovel handle rest.....	HB12E.....	15	2KH	12
1	Shovel support.....	HB12A.....	15	2KH	12
1	Spanner bracket (rear).....	HB15C.....	15	2KH	15
1	Spanner bracket.....	HB15H.....	15	2KH	15
	Including—				
1	Strap fastener, style No. 1.....	NBIA.....	15	2KN	1
1	Strap loop, style No. 1.....	NBIT.....	15	2KN	1
1	Spanner bracket plate.....	HB15E.....	15	2KH	15
	Including—				
1	Strap fastener, style No. 1.....	NBIA.....	15	2KN	1
1	Strap loop, style No. 1.....	NBIT.....	15	2KN	1
3	*Spring catches.....	HB43A.....	15	2KH	43
4	Strap fasteners, style No. 2.....	NBIB.....	15	2KN	15
	Including—				
4	Strap loops, style No. 1.....	NBIT.....	15	2KN	1
8	*Strap fasteners, style No. 5.....	NBIE.....	15	2KN	1
	Including—				
8	*Strap loops, style No. 1.....	NBIT.....	15	2KN	1
10	Strap fasteners, style No. 10.....	NBIL.....	15	2LN	1
2	Upper loose diaphragm brackets.....	10P.....	3	53	10
	Including—				
2	Upper loose diaphragm pins.....	10Q.....	3	53	10
2	Split pins (0.125 by 0.5 inch).....		30	2	1
1	Wrench holder.....	HB15B.....	15	2KH	15
	Chest door (lower), complete, consisting of—				
2	Apron hinges (female) (inner).....	GB5C.....	15	2KG	5
1	Apron hinge (female) (outer left).....	GB5M.....	15	2KG	5
1	Apron hinge (female) (outer right).....	GB5L.....	15	2KG	5
1	Chest door (lower).....	12B.....	3	53	12
1	Door angle (lower).....	22C.....	3	53	22
4	Door hinges (male).....	GBIS.....	15	2KG	1
1	Door stiffener (inner left).....	18H.....	3	53	18
1	Door stiffener (inner right).....	18G.....	3	53	18
2	Door stiffener (outer).....	18K.....	3	53	18
2	Pins, type A (0.368 by 1.26 inches).....	GB5D.....	15	2KG	5
	Including—				
4	Split pins (0.125 by 0.75 inch).....		30	2	1
2	Pins, type A (0.368 by 1.76 inches, A=1.26).....	GBIH.....	15	2KG	1
	Including—				
4	Split pins (0.125 by 0.75 inch).....		30	2	1

\* Not required for caisson equipped with reel, model of 1917.

Num- ber.	Name of part.	Piece mark.	Drawing.		
			Class.	Divi- sion.	Num- ber.
1	Chest door (upper), complete, consisting of—				
1	Chain No. 16.....	JB5D.....	15	2KJ	5
	Including—				
1	Bolt snap.....	JB5J.....	15	2KJ	5
2	Chain rings.....	JB5M.....	15	2KJ	5
1	Chain rivet.....	JB5L.....	15	2KJ	5
1	Padlock No. 850, "Ammunition".....	JB5K.....	15	2KJ	5
1	Chest door (upper).....	12A.....	3	53	12
1	Door angle (upper).....	22D.....	3	53	22
4	Door hinges (male).....	GBIC.....	15	2KG	1
1	Door prop stud (left).....	MB3E.....	15	2KM	3
	Including—				
1	Nut, crown (0.5 inch).....	Q6UA.....	30	2	6
1	Split pin (0.125 by 1.25 inches).....		30	2	1
1	Door prop stud (right).....	MB3D.....	15	2KM	3
	Including—				
1	Nut, crown (0.5 inch).....	Q6UA.....	30	2	6
1	Split pin (0.125 by 1.25 inches).....		30	2	1
1	Door stiffener (left).....	22G.....	3	53	22
1	Door stiffener (right).....	22F.....	3	53	22
1	Door stiffener (lower left).....	22L.....	3	53	22
1	Door stiffener (lower right).....	22K.....	3	53	22
1	Door stiffener (middle).....	22H.....	3	53	22
1	Foot rest.....	EB69F.....	15	2KE	69
	Including—				
1	Foot rest support (left).....	EB69C.....	15	2KE	69
4	Strap fasteners, style No. 5.....	NB1E.....	15	2KN	1
	Including—				
4	Strap loops, style No. 1.....	NBIT.....	15	2KN	1
1	Foot rest.....	EB69G.....	15	2KE	69
	Including—				
1	Foot rest support (right).....	EB69B.....	15	2KE	69
1	Wing nut.....	JB1Q.....	15	2KJ	1
	Including—				
1	Wing nut pin.....	JB1U.....	15	2KJ	1
1	Wing nut-pin washer.....	JB1R.....	15	2KJ	1
1	Connecting pole, complete, including—				
1	Body.....	LB13A.....	15	2KL	13
1	Bolt (0.625 by 4.437 inches).....	LB15B.....	15	2KL	13
1	Caisson prop connection.....	LB13G.....	15	2KL	13
1	Key bearing.....	LB13B.....	15	2KL	13
1	Lunette.....	AB9A.....	15	2KA	9
1	Lunette bearing.....	LB13D.....	15	2KL	13
2	Lunette pins.....	LB13N.....	15	2KL	13
1	Wheel guard.....	LB13C.....	15	2KL	13
	Including—				
1	Prop chain.....	LB13J.....	15	2KL	13
	Including—				
1	Prop eye.....	LB13K.....	15	2KL	13
1	Prop hook.....	LB13H.....	15	2KL	13
1	Prop eye bolt.....	LB13L.....	15	2KL	13
	Including—				
1	Split pin (0.125 by 0.75 inch).....		30	2	1
1	Prop hook bolt.....	LB13M.....	15	2KL	13
	Including—				
1	Split pin (0.125 by 0.75 inch).....		30	2	1
2	Door props, complete, including—				
2	Door proops.....	MB1P.....	15	2KM	1
2	Door prop sliding rivets.....	MB1C.....	15	2KM	1
1	Locking mechanism, complete, consisting of—				
1	Lock bar (left).....	14E.....	3	53	14
1	Lock bar (right).....	14F.....	3	53	14
1	Lock bar handle.....	JB19A.....	15	2KJ	19
4	Lock levers.....	JB19F.....	15	2KJ	19
1	Locking hinge pin.....	14P.....	3	53	14
3	Lock lever pins.....	JB19G.....	15	2KJ	19
8	Lock links.....	JB19H.....	15	2KJ	19
8	Lock link bushings.....	JB19K.....	15	2KJ	19
16	Washers, 0.25 inch.....	Q6WD.....	30	2	6
1	Loose diaphragm (lower), complete, consisting of—				
2	Diaphragm spacers (lower).....	10M.....	3	53	10
2	Loose diaphragm halves (lower).....	10B.....	3	53	10
1	Loose diaphragm (upper), complete, consisting of—				
1	Diaphragm spacer (upper bottom) (left).....	10K.....	3	53	10
1	Diaphragm spacer (upper bottom) (right).....	10H.....	3	53	10
2	Diaphragm spacers (upper top).....	10L.....	3	53	10
2	Loose diaphragm halves (upper).....	10A.....	3	53	10

Number.	Name of part.	Place m ark.	Drawing.		
			Class.	Division.	Number.
1	Pintle, complete, consisting of—				
2	Pintle bearing halves.....	AB3B.....	15	2KA	3
	Including—				
4	Bolts (0.825 by 2.5 inches).....	AB52B.....	15	2KA	52
4	Lock washers (0.625 inch).....		30	2	6
4	Nuts, crown (0.625-inch).....	Q6XA.....	30	2	6
4	Split pins (0.156 by 1.5 inches).....		30	2	1
1	Pintle.....	AB19A.....	15	2KA	19
	Including—				
1	Pintle latch.....	AB19B.....	15	2KA	19
1	Pintle latch pin.....	AB19D.....	15	2KA	19
1	Pintle latch spring.....	AB19C.....	15	2KA	19
1	Pole socket, complete consisting of—				
1	Bolt (0.75 by 2.812 inches).....	15B.....	3	53	15
	Including—				
1	Nut, crown (0.75-inch).....	Q6ZA.....	30	2	6
1	Split pin (0.156 by 1.5 inches).....		30	2	1
1	Connecting pole key.....	LB11D.....	15	2KL	11
1	Pole pin.....	LB11B.....	15	2KL	11
1	Pole socket.....	15A.....	3	53	15
2	Spring supporting mechanisms, complete, consisting of—				
32	Bellefonte springs.....	AB21B.....	15	2KA	21
8	Carrying springs.....	AB21C.....	15	2KA	21
4	Guide bolts.....	17H.....	3	53	17
	Including—				
4	Handy oilers (0.375-inch).....	Q2H.....	30	2	2
4	Nuts, crown (0.75-inch).....	17K.....	3	53	17
4	Split pins (0.156 by 1.5 inches).....		30	2	1
4	Washers (0.75-inch).....		30	2	6
8	Spring bolts.....	17G.....	3	53	17
	Including—				
8	Nuts, crown (0.75-inch).....	17L.....	3	53	17
8	Split pins (0.156 by 1.5 inches).....		30	2	1
8	Spring bolt heads.....	AB50C.....	15	2KA	50
	Including—				
8	Split pins (0.156 by 1.5 inches).....		30	2	1
4	Spring bolt washers.....	AB50B.....	15	2KA	50
4	Spring bolt head lock.....	AB50A.....	15	2KA	50
2	Wheels, complete, consisting of—				
2	Hub caps.....	PB6K.....	15	2KP	6
	Including—				
2	Hub latches.....	PB16A.....	15	2KP	16
	Including—				
2	Hub latch plungers.....	PB16C.....	15	2KP	16
2	Hub latch springs.....	PB16B.....	15	2KP	16
2	Rivets (0.125 by 0.562 inch).....				
2	Oil valves.....	PB5F.....	15	2KP	5
	Including—				
2	Oil valve rivets.....	PB5E.....	15	2KP	5
2	Split pins (0.093 by 0.875 inch).....		30	2	1
2	Springs.....	PB5D.....	15	2KP	5
2	Washers.....	PB5G.....	15	2KP	5
2	Wheels, including—				
2	Brake drums.....	BB28A.....	15	2KB	28
16	Carriage bolts (0.75 by 5.125 inches).....	PB7C.....	15	2KP	7
	Including—				
16	Nuts (0.75-inch).....	Q6H.....	30	2	6
8	Felloe segments.....	PB55C.....	15	2KP	55
2	Hub bands.....	PB6J.....	15	2KP	6
2	Hub boxes.....	PB7A.....	15	2KP	7
2	Hub liners.....	PB7B.....	15	2KP	7
2	Hub rings.....	PB7F.....	15	2KP	7
2	Lock washers.....	PB6R.....	15	2KP	6
16	Spokes (left).....	PB55B.....	15	2KP	55
16	Spokes (right).....	PB55A.....	15	2KP	55
32	Spoke shoes.....	PB21F.....	15	2KP	21
32	Spoke shoe plates.....	PB21D.....	15	2KP	21
32	Spoke shoe rivets.....	PB21G.....	15	2KP	21
2	Tires.....	PN21H.....	15	2KP	21
16	Tire bolts.....	PB6A.....	15	2KP	6
	Including—				
16	Nuts, square.....				
16	Washers (0.43 by 1 inch).....				
2	Wheel hooks.....	PB6Q.....	15	2KP	6
2	Wheel hook bushings.....	PB7E.....	15	2KP	7
2	Wheel fastenings.....	PB6P.....	15	2KP	6
	Including—				
2	Plugs.....	PB16F.....	15	2KP	16
2	Rivets (0.093 by 1 inch sunk head bronze).....				
2	Wheel fastening plungers.....	PB16D.....	15	2KP	16

Num- ber.	Name of part.	Piece mark.	Drawing.		
			Class.	Divi- sion.	Num- ber.
	ADDITIONAL PARTS REQUIRED FOR THE CAISSON EQUIPPED WITH REEL, MODEL OF 1917.				
1	Crank (right), complete, consisting of—				
1	Crank (right).....	4A.....	22	43	4
1	Handle.....	4E.....	22	43	4
1	Handle washer.....	4D.....	22	43	4
1	Key.....	4C.....	22	43	4
1	Spindle.....	4B.....	22	43	4
1	Spindle washer.....	4F.....	22	43	4
1	Crank shaft, complete, consisting of—				
1	Crank (left).....	3D.....	22	43	3
	Including—				
1	Handle.....	4E.....	22	43	4
1	Handle washer.....	4D.....	22	43	4
1	Safety chain.....	3G.....	22	43	3
	Including—				
1	Chain ring.....	JB5M.....	15	2KJ	5
1	Safety chain ring.....	3E.....	22	43	3
1	Safety chain double ring.....	3F.....	22	43	3
1	Split pin (0.156 by 1.5 inches).....		30	2	1
1	Spindle.....	4B.....	22	43	4
1	Spindle washer.....	4F.....	22	43	4
1	Crank bearing.....	3Q.....	22	43	3
	Including—				
1	Hinge pin.....	3R.....	22	43	3
1	Crank shaft.....	5F.....	22	43	5
	Including—				
1	Crank shaft collar.....	3N.....	22	43	3
1	Driving gear.....	5E.....	22	43	5
1	Frame, complete, consisting of—				
1	Bearing cap.....	5C.....	22	43	5
2	Bearing cap pins.....	4N.....	22	43	4
	Including—				
2	Wing nuts.....	JB8D.....	15	2KJ	8
1	Brake lever.....	3M.....	22	43	3
	Including—				
1	Thong.....	4P.....	22	43	4
1	Brake lever pin.....	3L.....	22	43	3
1	Brake release spring.....	4Q.....	22	43	4
1	Cap hinge pins.....	5D.....	22	43	5
2	Chains (4.41 inches long).....	JB5C.....	15	2KJ	5
	Including—				
2	Bolt snaps (0.625-inch).....	JB5J.....	15	2KJ	5
4	Chain rings.....	JB5M.....	15	2KJ	5
2	Chain rivets.....	JB5L.....	15	2KJ	5
1	Chain.....	JB5C.....	15	2KJ	5
	Including—				
1	Chain ring.....	JB5M.....	15	2KJ	5
1	Chain rivet.....	JB5L.....	15	2KJ	5
1	Crank ring.....	4G.....	22	43	4
4	Corner reinforces.....	2E.....	22	43	2
3	Crank fastenings.....	4M.....	22	43	4
1	Crank rest.....	3H.....	22	43	3
1	End (left).....	2D.....	22	43	2
1	End (right).....	2A.....	22	43	2
1	Name plate.....	4R.....	22	43	4
1	Shaft bearing (left).....	5A.....	22	43	5
1	Shaft bearing (right).....	5B.....	22	43	5
2	Sides.....	2F.....	22	43	2
1	Washer.....	3K.....	22	43	3
1	Spool, complete, consisting of—				
1	Pinion.....	5H.....	22	43	5
1	Shaft.....	5G.....	22	43	5
1	Spool flange hub.....	3P.....	22	43	3
1	Spool flange (left).....	2C.....	22	43	2
1	Spool flange (right).....	2B.....	22	43	2
2	Spool hub halves.....	3A.....	22	43	3
	Including—				
6	Wood screws.....	3C.....	22	43	3
4	Tie-rods.....	3B.....	22	43	3

**DESCRIPTION OF THE CAISSON.**

(Plates XXXII, XXXIII, and XXXIV.)

The 155 mm. howitzer caisson, model of 1918, is a two-wheel spring supported vehicle for the transportation of ammunition. It is normally a motorized vehicle, two caissons forming a train drawn by one 5-ton tractor. However, by removing the connecting pole and substituting the standard pole, the front vehicle of the train can be converted into a horse-drawn caisson limber. Any caisson in the battery except the caisson equipped with the reel can be so converted into a caisson limber.

**THE CHEST.**

The chest is made up of the lower chest body, upper chest body, and rear plate, the latter being made of armor plate. The plates are held together and stiffened by angles which are riveted to them. The chest is divided into an upper and lower compartment by the upper and lower intermediate plates, which are riveted to the sides and rear of the chest, the opening between them forming a space for the axle, pole socket, pintle bracket, fuze box, and oil can.

The upper compartment is arranged for the transportation of 8 projectiles and 16 powder charges. The front and rear diaphragms are riveted to the chest body and perforated with 16 holes arranged in three horizontal rows. The top row and three center holes of the middle row of each diaphragm are connected by carrier tubes which are rolled in place, each providing space for one powder container. Powder is served to the caissons in fiber containers, each containing two powder charges. The container is fitted with a metal cover and base, the cover being pressed in, thereby procuring an air-tight joint. The middle diaphragm of the upper compartment is riveted in place between the front and rear diaphragms and perforated with eight holes. These holes are connected with the lower row and the two end holes of the middle row of the front diaphragm by projectile tubes which are rolled in place, each providing space for one projectile. The diaphragms are stiffened and kept in proper alignment by seven bolts, which pass through gas pipe diaphragm stiffeners.

The lower compartment is arranged for the transportation of 6 projectiles. The front, middle and rear diaphragms are riveted to the body and each perforated with six holes. The holes in the middle and front diaphragms are connected by projectile tubes which are rolled in place, each providing space for one projectile.

The upper chest door, made of armor plate, is hinged to the upper chest body and when closed forms a cover for the chest. The door is held open by the door props, the ends of which are attached to

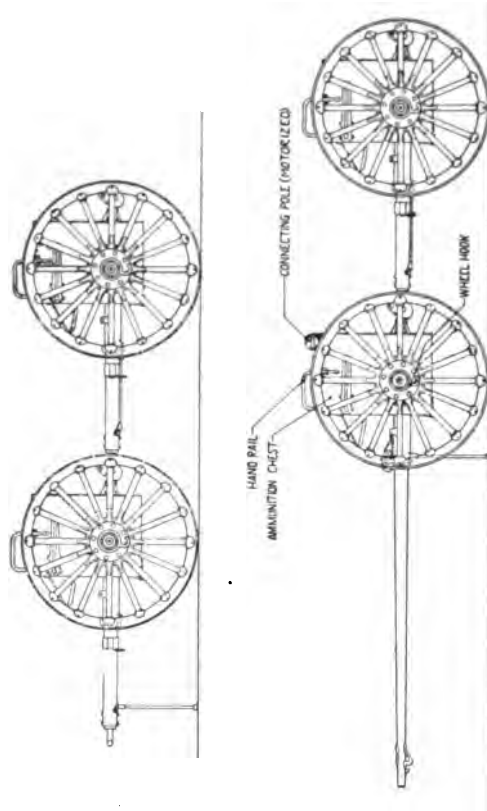

155 MM. HOWITZER CAISSON  
MODEL OF 1918  
LIMBERED



the rear plate for carrying the lunette and caisson prop when the caisson is used as a horse-drawn vehicle.

A name plate, giving the name of the vehicle, date of completion, initials of the inspector and serial number, is riveted to the rear plate. In reports, correspondence, etc., the battery personnel is directed to give the name of the vehicle and serial number.

The pole socket is riveted into the front of the chest between the upper and lower intermediate plates. The pole fits into the pole socket and is held in place by the connecting pole key. The lunette bearing is riveted into the front end of the pole. A wheel guard is riveted to the pole near the rear end. The caisson prop is pinned to the caisson prop connection and consists of two prop tubes, into the upper end of which prop eyes are riveted, the lower ends being fitted with a prop foot. When down the prop serves to support the front end of the caisson. In traveling it is swung up and held by the prop chain.

A T slot is provided in the top surface of the pole socket for receiving the doubletree adapter. The latter is held in place by a key passing through two square lugs on top of the pole socket. Four horse poles, doubletrees, and doubletree adapters are issued to motorized batteries for use in emergencies. The poles are also made available for use on the carriage limbers by means of a special pole socket, four of which are issued to motorized batteries.

#### SPRING SUPPORT MECHANISM.

The axle passes through the caisson between the upper and lower intermediate plates. The axle brackets, Plate XXXIV, are clamped on either end of the axle just outside of the chest, and rotation or lateral motion of the axle is prevented by the axle-bracket clamp screws. The axle brackets fit into the front and rear guide brackets, which are riveted to the sides of the chest. Belleville springs are placed between the guide brackets and the lower sides of the axle brackets. The carrying springs are placed on top of the axle brackets. Spring bolts are mounted in the lower flange of the guide brackets and pass through the Belleville springs, axle brackets, and carrying springs. Spring-bolt washers are placed over the springs and spring-bolt heads are screwed into the upper ends of the spring bolts, locked in place by the spring-bolt head locks, the latter also serving to hold each pair of spring bolts in proper alignment. Lateral motion of the chest is prevented by guide bolts which pass through either end of the axle brackets and guide brackets. The downward motion of the chest is limited by chest stops which are riveted to the chest just above the axle brackets.

#### THE ROAD BRAKE.

The caisson is provided with a brake mechanism of the drum type, Plate XXXIV. The brake drums are mounted on the hub boxes of the wheels and held in place by carriage bolts. The brake-hanger brackets are mounted on the under side of the axle brackets and held in place by the axle bracket clamp screws, forming supports for the brake hangers. The brake bands are lined with Raybestos liners and are pinned at one end to the brake hangers. The free ends of the brake bands are pinned to the brake-rod levers which are pivoted to the brake hangers. The brake bands are prevented from dragging on the drums by band guides riveted to the upper sides of the bands and anchored in the band clips which are pinned into the axle brackets.

The lower ends of the brake-rod levers are attached through the brake rods to the brake-shaft levers, adjustment being provided for by means of brake-rod ends which are screwed to the brake rods. One brake-shaft lever is made integral with the brake shaft, the other is mounted on the square cut on the left end of the brake shaft and is held in place with a split pin. The brake-hanger brackets are stiffened and braced by brake-hanger bracket braces, the front ends of which are pinned between the sides of the chest and the brace supports.

The brake lever is riveted into the brake-lever bearing and the latter is mounted on the brake-lever pin. The pin is forced and pinned in the brake-lever bracket which is riveted to the caisson body. The brake-lever rod is pinned at the lower end to the crank on the brake shaft and, at the upper end, to the brake-lever bearing. The upper end of the brake-lever rod is screwed into a brake-rod end, allowing for adjustment in the length of the rod.

A segment rack is mounted on the segment-rack bracket which is riveted to the caisson body just above the brake-lever bracket. A brake-lever catch mounted on the lever engages this rack and holds the lever in any desired position.

#### THE WHEELS.

The caisson wheels are of wooden construction, steel tired, and 60 inches diameter. The spokes are mounted between the hub box and hub ring and held in place by carriage bolts, which also hold the brake drums in place. The outer ends of the spokes fit into spoke shoes which are riveted to a felloe made up of four sections. The tire is shrunk around the felloe and held with tire bolts passing through the felloe.

The hub liners are forced into the hub boxes and the wheels are held on the axle by wheel fastenings. The wheel hook bushings

are mounted on the hub boxes and keyed to the hub rings. The wheel hooks fit over and revolve on these bushings. The hub bands are screwed to the hub boxes, lock washers being placed between the wheel-hook bushings and the hub bands. The hub caps are screwed to the axle and locked to the hub bands by the hub latches. Wheel oil valves are mounted in the hub caps, and held closed by springs. Small rivets in the sides of the valves enable them to be locked in open position.

#### THE REEL.

One caisson in each battery is equipped with the Reel for Caisson, model of 1917. This is a hand operated reel for the transportation and handling of telephone wires.

The frame is built up of two flanged steel ends and two sides, riveted together with four angle-iron corner reinforces and riveted to the top of the chest. The reel is built up of two flanged steel spool flanges mounted on a shaft. The spool flange hub is riveted to the right spool flange and a basswood spool hub, made in two pieces, is mounted between the spool flanges, the latter being held together by four tie-rods.

The spool may be operated from either side. The crank on the right side is mounted on the shaft and is attached to the right end of the frame by a chain. When not in use the crank can be removed and placed in the crank fastenings. The crank on the left side is connected with the spool through an 18 to 40 gear reduction. The crank is attached by a hinge pin to the crank-shaft collar, which is mounted on the outer end of the crank shaft. The latter passes through a bearing in the left shaft bearing and is fitted with a driving gear on the opposite end. The driving gear meshes with a pinion on the shaft of the spool. By removing the safety-chain split pin the left crank can be turned back and placed in the crank rest when not in use. Chains are provided on either end of the frame for locking the cranks when not in use.

The reel is also fitted with a brake for controlling the speed of rotation when allowing wire to run out. The brake lever is pivoted on the brake-lever pin, which is riveted into the left shaft bearing and operated by a thong attached to the lower end of the lever. By pulling the thong the upper end of the lever is made to drag on the inside of the rim of the left spool flange. A brake-release spring, attached to the upper end of the lever, and a lug on the left shaft bearing, keeps the brake open when not in use.

A name plate riveted on the rear side of the frame gives the name of the reel, the serial number, the year in which it was completed, and the initials of the inspector.

The caisson equipped with the reel can not be converted into a horse-drawn caisson limber, no provision having been made for carrying the connecting pole. The ax fastenings and limber blanket straps are also omitted from this caisson.

### ANTIAIRCRAFT MACHINE GUN.

(Plate XXXV.)

The antiaircraft machine guns as issued to a battery of 155-mm. howitzers, motorized, consists of three units: Browning machine gun, model of 1917; Browning machine gun tripod, model of 1917; anti-aircraft machine gun trailer, model of 1918.

Further information concerning these units will be found in Ordnance Handbooks:

“Browning Machine Gun, Model of 1917, Caliber .30—Water-cooled.”

“Antiaircraft Machine Gun Trailer, Model 1918.” (No. 1980.)

#### WEIGHTS AND DIMENSIONS.

Weight of gun, no water.....	30 lbs.=13.6 kg.
Weight of gun, filled.....	36.75 lbs.=16.7 kg.
Weight of belt, 250 rounds.....	15.25 lbs.=6.9 kg.
Weight of belt, empty.....	7.5 oz.=213 grams.
Length of the barrel.....	24 in.=610 mm.
Sight graduated to.....	2,800 meters.
Caliber of bore.....	0.30 in.=7.62 mm.
Rate of fire (shots per min.).....	400-525.
Aimed shots per minute.....	120.
Weight of bullet (Cupro-nickel).....	150 grains=9.72 grams.
Weight of powder.....	47.50 grains=3.05-3.24 grams.
Weight of cartridge.....	394 grains=25.5 grams.
Chamber pressure.....	47,000 to 50,000 lbs./sq. in.=3,304 to 3,515 kg./sq. cm.
Muzzle velocity (theoretical).....	2,700 ft. per sec.=823 meters per sec.

#### GENERAL DESCRIPTION.

The Browning machine gun, model of 1917, is chambered for the United States caliber .30, model of 1906, ammunition. The gun is classified as heavy, water-cooled, recoil-operated, and belt-fed.

On account of its weight, the Browning machine gun is usually fired from a tripod or other suitable fixed mount. The gun is well adapted to both direct and indirect fire, and is capable of maintaining continuous fire almost indefinitely, if the water jacket is periodically refilled. A flash hider is furnished and is used for night firing. The gun is of very simple construction, and replacements are easily and quickly made. In the design of the gun special care was taken to reduce to a minimum the various sudden shocks which are imposed upon the moving parts.

PLATE XXXIV

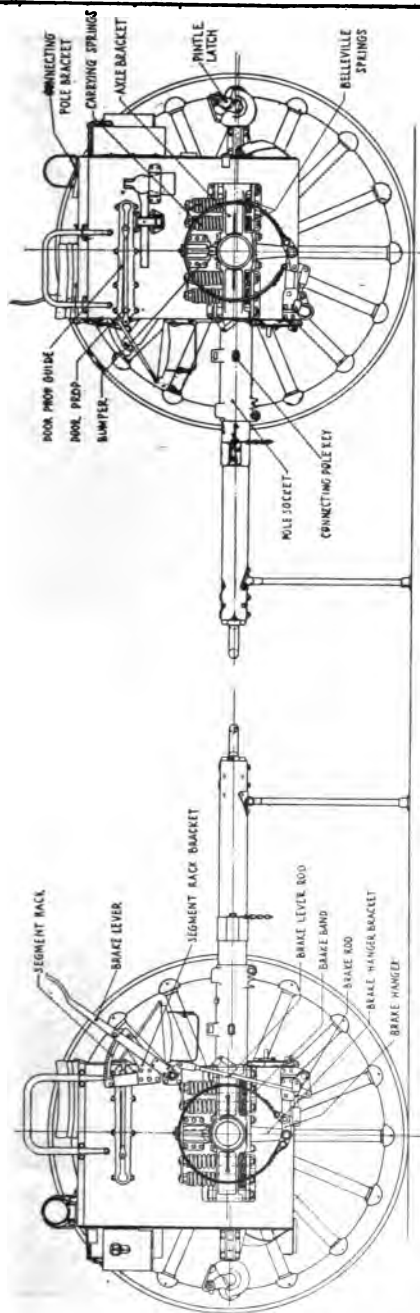

155 MM. HOWITZER CAISSON  
MODEL OF 1918  
SIDE ELEVATIONS (NEAR WHEEL REMOVED).

0 1 2 3 4 5 6 7 8 9 10 11 12 13 14 15 16 17 18 19 20 21 22 23 24 25 26 27 28 29 30 31 32 33 34 35 36 37 38 39 40 41 42 43 44 45 46 47 48 49 50 51 52 53 54 55 56 57 58 59 60 61 62 63 64 65 66 67 68 69 70 71 72 73 74 75 76 77 78 79 80 81 82 83 84 85 86 87 88 89 90 91 92 93 94 95 96 97 98 99 100

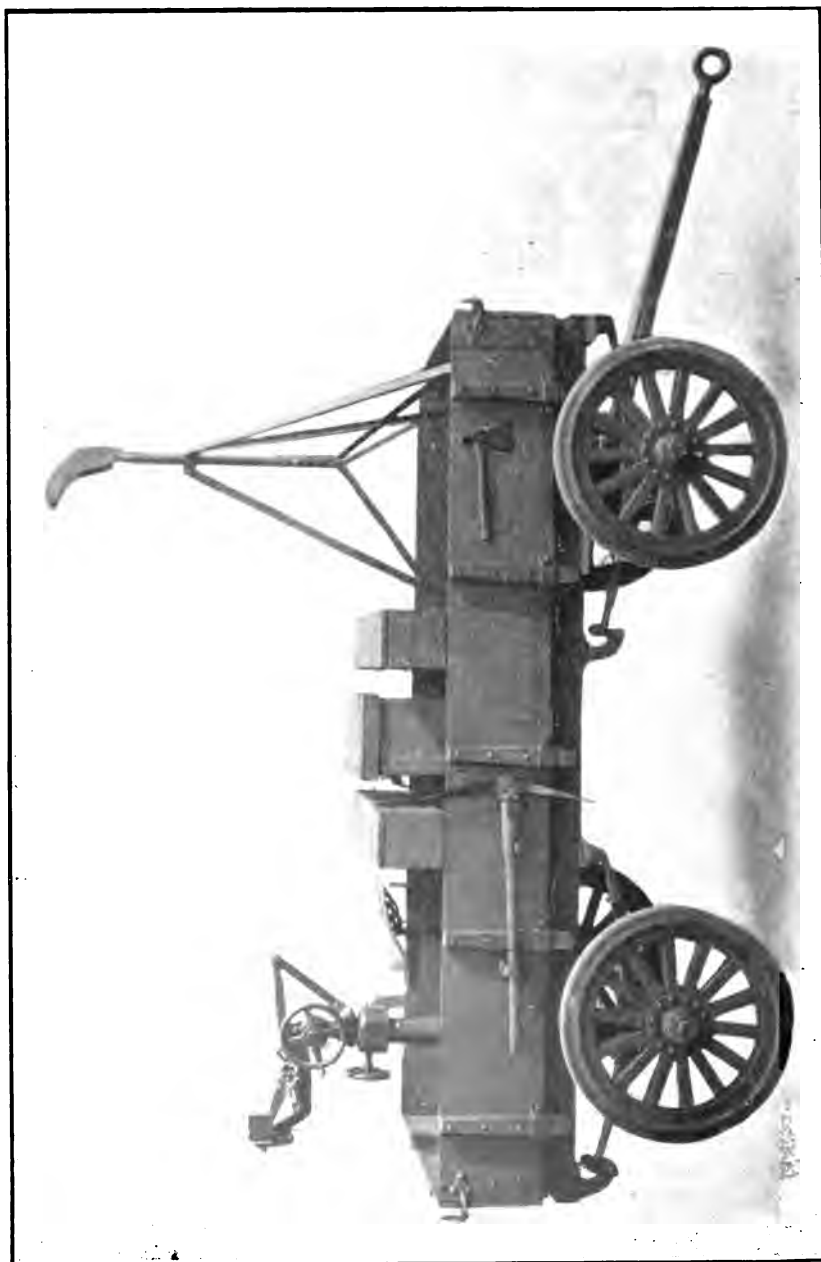

Antique Mechanical Traction Engine, Model of 1918.

Cooling is effected by a water jacket surrounding the barrel, the barrel being located near the lower surface of the jacket. This jacket is provided with inlet and outlet water plugs, as well as a steam outlet near the front end. Steam tubes are located in the upper part of the jacket and operate in such a way as to draw the steam from the highest level of the jacket. One end of the steam-condensing device can be clamped to the stem and the opposite end placed in a water box, thus condensing the greater portion of the steam formed by continuous firing.

The Browning gun is operated by the recoil force of the cartridge explosion. This force drives the barrel to the rear for a short distance, unlocking the bolt. During this rearward movement of the barrel the action of the accelerator separates the bolt from the barrel extension and throws the bolt completely to the rear. As the bolt leaves the barrel, it extracts the empty shell from the chamber and a live cartridge from the belt, drawing them both to the rear and ejecting the empty case. As soon as the bolt strikes the buffer, it starts on its forward movement, which places the live cartridge in the chamber of the barrel which has been held in its rearmost position. As soon as the bolt reaches it the barrel is released. The bolt and barrel then move forward together and the bolt is locked to the barrel extension. If the trigger has been held back, the next shot is fired as soon as the mechanism has reached its forward position.

The Browning water-cooled gun is fed from a fabric belt containing 250 rounds. Expendable fabric and paper belts are also used considerably in connection with this gun, some of which have a capacity of 300 rounds.

#### ANTI-AIRCRAFT MACHINE-GUN MOUNT, CYGNET TYPE.

This mount as used on the Sechler trailer consists of a high type steel pedestal carrying a revolving hub, mounted on ball bearings, which supports a horizontally traversible seat for the machine gunner and a vertically and horizontally traversible gun head which permits the gun to be traversed through 360° in azimuth and from 15° depression to 90° elevation. The hub is provided with handle-operated means for clamping it against the pedestal and preventing the horizontal rotation of the mount.

The elevating mechanism is made up of three tubes, the outer tube being fastened rigidly to the hub and having an adjusting nut which is located at the bottom of the pedestal. The elevating tube is provided with a bushing at the lower end which slides in the outer tube and is fastened rigidly at the top to a gear case and to the elevating tube bushing. The inner or elevating screw tube is fastened at the bottom of the mount to the adjusting screw nut and is provided at the top with a threaded bushing which takes the elevating screw.

The elevating screw is operated by a handwheel, horizontal shafts, and bevel gears; the handwheel being located at the left side of the gunner when seated. The gear-case cap serves as a bearing for the gun arm as well as a covering for the gears.

Means for obtaining accurate elevation of the gun is provided by an elevating screw and nut which connects to the rear of the gun adapter and the worm-wheel arm.

The following machine guns are applicable to this mount when the adapter peculiar to each gun is used:

Browning machine gun, model of 1917.

Vickers machine gun, model of 1915.

Marlin tank machine gun, model of 1918.

Marlin aircraft machine gun, model of 1917.

Hotchkiss machine gun, model of 1914.

Colt machine gun, model of 1917.

Browning automatic rifle, model of 1918.

Lewis machine gun, model of 1917.

The following adapters are interchangeable with those used on the antiaircraft machine-gun tripod, model of 1918, which has been mounted on the Sechler trailer together with the Cygnet mount; they are also interchangeable with the adapters used on the improvised post mount:

Browning and Vickers adapter, used for either the Browning or Vickers machine guns.

Colt, Marlin aircraft, and Marlin tank adapter, used for either Colt, Marlin aircraft, or Marlin tank machine guns.

Hotchkiss adapter, used for Hotchkiss machine gun.

Lewis adapter, used for Lewis machine gun.

Browning automatic rifle adapter, used for this rifle.

#### ANTIAIRCRAFT MACHINE-GUN TRIPOD, MODEL 1918.

The antiaircraft machine-gun tripod, model of 1918, was designed and developed to provide a convenient and suitable method of supporting a machine gun at a convenient height, approximately 5 feet above the ground, and at the same time allowing the gun to be freely turned by hand through 360° in a horizontal plane and elevated freely by hand from approximately 15° depression to 90° elevation.

The tripod consists of three legs of T-section steel supporting a central adjustable staff by means of a clamping bearing attached to the upper end of the three legs. The bottoms of the legs are provided with cast feet similar to those used on the Browning machine-gun tripod, model of 1917.

The bracket swings freely about the upper part of the staff in a similar way to the action of the bracket on the pin of the improvised post mount. The bracket will receive the adapters as designed for

the improvised post mount and the antiaircraft machine-gun mount (Cygnet type). On the lower end of the central staff a ring is provided to engage means of clamping the tripod to the floor of a trailer if desired. The bracket can be removed and the legs and braces folded up for transportation, the tripod weighing approximately 60 pounds.

#### BROWNING MACHINE-GUN TRIPOD, MODEL OF 1917.

The Browning machine-gun tripod, model of 1917, consists of four major parts: The legs, the socket, the pintle, and the cradle. The legs are steel tubing, having the feet attached to one end and the serrated connections to the other. The socket is of manganese bronze and is the part to which the legs are assembled, in which the pintle revolves and in which the slow-motion mechanism and stops are attached. The traversing clamp is also attached to the socket. The pintle is the center member of the tripod and carries the cradle clamp and traversing stop pin. The cradle is attached to the top of the pintle and is used to allow a quick elevation or depression of the gun. It carries at its rear end the elevating mechanism, which allows a micrometer adjustment to the gun in elevation.

The mount has a 360° free traverse, graduated on an adjustable dial at 20-mil intervals for 6,400 mils; a traversing clamp; a slow-traversing worm mechanism, graduated in 2-mil intervals, and traversing stops adjustable to a single mil, both having a quick throw-off to allow for free traverse; an elevating mechanism of 125 mils capacity and graduated to 1 mil on an adjustable dial; and a cradle construction on the pintle which allows a quick elevation or depression of 30° each way, with graduation marks at 12½-mil intervals. The weight is approximately 50 pounds.

#### STAFF OBSERVATION CAR.

(Plate XXXVI.)

The staff observation car as issued to regiments of 155 mm. howitzers, model of 1918, motorized, consists of two units: Staff observation car body, model 1918; one-ton truck chassis, White, model TEB-O.

Further information concerning these two units will be found in ordnance handbook (1964) "Staff observation car, model of 1918."

TABLE OF WEIGHTS AND OUTLINE SPECIFICATIONS.

Rated load capacity (body allowance plus normal load)....	1 ton=910 kg.
Body weight allowance.....	1,500 lb.=682 kg.
Chassis only.....	3,850 lb.=1,750 kg.
Oil, water, and gasoline.....	190 lb.=86.4 kg.
Chains.....	69 lb.=31.4 kg.
Tool kit.....	37 lb.=16.8 kg.



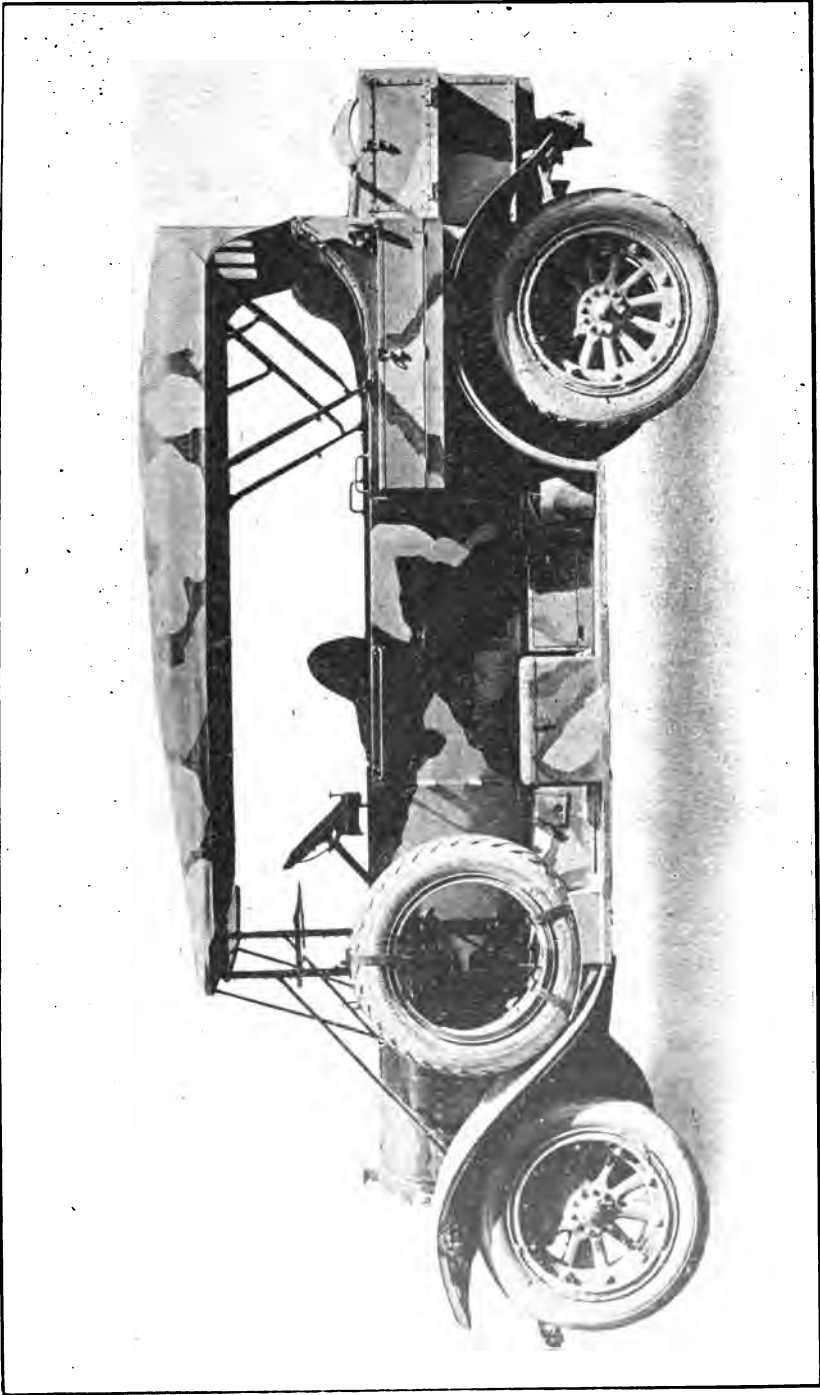

Staff Observation Car.

PLATE XXXVII

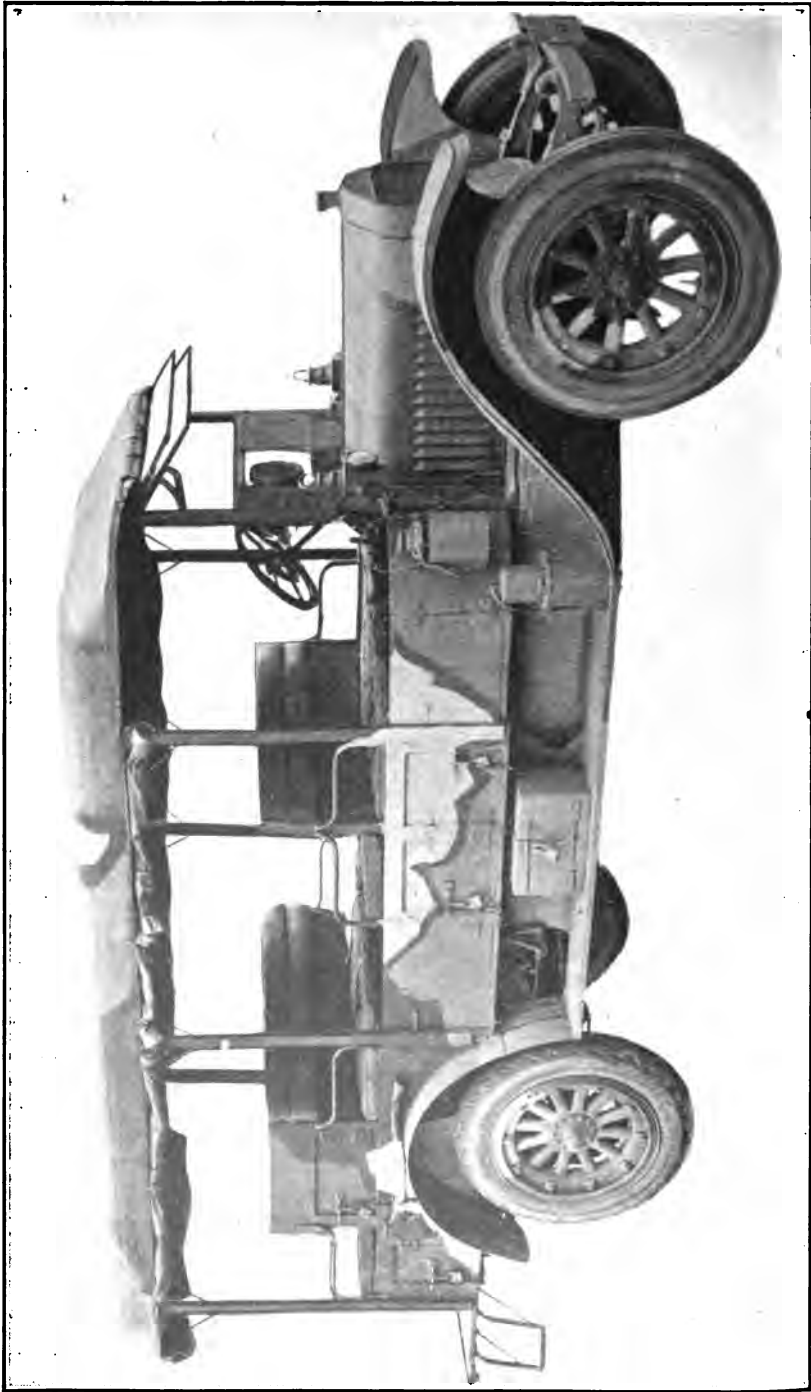

Reconnaissance Car.

are used as suitable receptacles for the shovels, axes, etc., which are standard equipment. Body tool boxes are carried on each side of the tonneau behind the rear mud guards. A long tool box is supported on the right running board and a small one on the left to the rear of the battery box. A storage compartment is provided under the rear seat and two in the floor of the tonneau. On the back of the front seat, on each of the rear doors and on each side of the tonneau back of the doors, there are large bellows type pockets in which maps, papers, etc., may be conveniently carried. The rear compartment in the floor of the tonneau is used as a receptacle for the storage of a small table.

#### BRIEF DESCRIPTION OF WHITE CHASSIS, MODEL TEB-O.

**ENGINE.**—Four-cylinder, four-cycle, L-head cylinders cast in block. Bore, 4.25 ( $4\frac{1}{4}$ ) inches; stroke, 6.375 ( $6\frac{3}{8}$ ) inches; 28.9 horsepower, N. A. C. C. formula.

**COOLING.**—Centrifugal pump water circulation.

**RADIATOR.**—Cellular type, unit shell and core. Spring mounted.

**OILING.**—Special White system.

**IGNITION.**—Eisemann high-tension magneto, type G-4.

**CARBURETER.**—Double jet White special, with hot-air stove.

**FUEL FEED.**—Gravity, from tank under front seat.

**CLUTCH.**—Single plate, running in oil.

**TRANSMISSION.**—Selective sliding gear, four speeds forward and one reverse.

**DRIVE.**—Shaft drive, through two universals to plain bevel pinion and gear.

**PROPULSION.**—Through two radius rods.

**TORQUE.**—Through rear springs.

**FRAME.**—Channel section, pressed steel. Four cross members.

**SPRINGS.**—Front—semielliptical 40.625 ( $40\frac{5}{8}$ ) inches long, 2 inches wide, 10 leaves. Rear—semielliptical, 50.375 ( $50\frac{3}{8}$ ) inches long, 2.25 ( $2\frac{1}{4}$ ) inches wide, 11 leaves.

**AXLES.**—Rear—built-up housing, semifloating type, wheels running on ball bearings. Incorporating bevel pinion and ring gear and bevel pinion type differential, mounted on ball bearings. Front—drop forging, I-beam section carbon steel, heat treated. Adjustable tie rod. Ball pedestal bearing on spindle body. Wheels mounted on ball bearings.

**BRAKES.**—Two sets: Pedal-operated service brake, external contracting. Hand-operated emergency brake, internal expanding. Both brakes engage with brake drums on rear wheels.

**TIRES.**—36 inches by 6 inches, pneumatic.

**STEERING.**—Front wheels only used for steering. Steering gear of worm and sector type. Eighteen-inch wood steering wheel.

**CONTROLS.**—Left-hand steering gear, with gear shift lever at right of driver. Emergency brake at driver's left. Spark and throttle levers mounted on sector in steering wheel. Ignition ground switch located on side of control box on dash. Carbureter choke on left side of dash. Lighting switches, speedometer, and ammeter in control box on dash. Accelerator pedal located on base of steering-gear column. Clutch and brake pedals located from left to right, respectively.

**LIGHTING.**—Two electric headlights, two oil-electric side lamps, oil-electric tail lamp, electric dash light.

**STARTING.**—Two-unit, Leece-Neville 6-volt system. Generator has ground return. Motor is double wired, and equipped with a Bendix drive, engaging with the flywheel. Switch is under driver's heel.

**BATTERY.**—The starting and lighting battery is a Willard type STR4, 6-volt, and of 128 ampere-hour capacity.

A complete description with instructions for care, maintenance, and operation is contained in the "Handbook of the Staff Observation Car, Model of 1918," Ordnance Pamphlet No. 1964.

## RECONNAISSANCE CAR.

(Plate XXXVII.)

The reconnaissance car as supplied to regiments of 155 mm. howitzers, motorized, consists of two units: Reconnaissance body, model 1918; 1-ton truck chassis, White, TEB-O.

Further information concerning these units will be found in Ordnance handbooks "Reconnaissance Body, Model 1918;" "1-Ton Truck Chassis, White, TEB-O." (No. 1972.)

### WEIGHTS, PRINCIPAL DIMENSIONS, ETC.

Rated load capacity (body allowance plus normal load)....	1 ton=1,040 kg.
Body weight allowance.....	1,500 lb.=862 kg.
Chassis only.....	3,850 lb.=1,750 kg.
Oil, water, and gasoline.....	190 lb.=86.5 kg.
Chains.....	69 lb.=31.5 kg.
Tool kit.....	37 lb.=16.8 kg.
Chassis weight on front tires (without load).....	54 per cent.
Chassis weight on rear tires (without load).....	46 per cent.
Gross weight (capacity load).....	7,150 lb.=3,250 kg.
Load weight on front tires.....	0.78 per cent.
Load weight on rear tires.....	99.22 per cent.
Gross weight on front tires.....	27 per cent.
Gross weight on rear tires.....	73 per cent.
Overall length of chassis (without body).....	205 in.=5,220 mm.
Overall width of chassis (at widest part).....	61 in.=1,550 mm.
Chassis wheel base.....	140 in.=3,560 mm.
Permissible loading space back of driver's seat.....	97 in.=2,470 mm.
Width of frame (outside dimension, widest part).....	34 in.=865 mm.
Height of rear end of frame from ground (empty).....	33.75 in.=856 mm.
Diameter of turning circle	
right.....	60 ft.=18.3 meters.
left.....	45 ft.=13.7 meters.

Tread of wheels.....	56 in.=1,422 mm.
Road clearance under front axel (lowest point).....	10.75 in.=273 mm.
Road clearance under rear axel (lowest point).....	10 in.=254 mm.
Length of reconnaissance body over all.....	160 in.=4,072 mm.
Width of body.....	59.875 in.=1,522 mm.
Height of body over all (including top).....	62.125 in.=1,580 mm.
Weight of body (without equipment).....	1,180 lb.=536 kg.

#### BRIEF DESCRIPTION.

The reconnaissance car is provided with a special steel body mounted on a 1-ton truck chassis, White, Model TEB-O. Four seats are built into the body. The two front seats are placed back to back. The two rear seats have a space of about 2 feet between them, and are also placed back to back. There is a compartment between the two pairs of seats. The floor boards at the back end are extended to form a foot rest for the rear seat. The car is protected by a canopy top and roll curtains. A full set of tools is carried on the car. Also five chests are provided in which are carried all the special equipment assigned to the car. One chest slides into the body compartment under the rear front seat, one into the compartment between the two rear seats, and the other three under the rear rear seat.

The chassis used is similar to that used with the Staff Observation car on page 95. A complete description and directions for care, operation, and maintenance are contained in "Handbook of the Reconnaissance Car, Model of 1918." Ordnance pamphlet No. 1972.

### ARTILLERY TRACTOR, 2½-TON.

(Plate XXXVIII.)

The Artillery tractor, 2½-ton, as supplied to regiments of 155-mm. howitzers, model of 1918, motorized, consists of one unit: Artillery tractor, 2½-ton, model of 1918.

Further information concerning this unit will be found in Ordnance handbook, "Artillery Tractor, 2½-ton, Model of 1918" (No. 2009).

#### WEIGHTS AND DIMENSIONS.

Over-all length, armored.....	113.5 in.=2,883 mm.
Over-all width.....	57.75 in.=1,467 mm.
Width of armor.....	33 in.=838 mm.
Maximum height.....	75 in.=1,905 mm.
Height to top of armor.....	60.5 in.=1,537 mm.
Length of ground contact (track 3 inches in ground).....	71 in.=1,803 mm.
Ground clearance without grousers.....	13.5 in.=343 mm.
Ground clearance with grousers.....	15.25 in.=387 mm.
Weight complete, with full equipment.....	5,810 lbs.=2,635 kg.

Ground pressure.....	5.1 lbs. per sq. in.=0.359 kg. per sq. cm.
Weight of each track.....	530.5 lbs.=240.6 kg.
Weight of each track shoe.....	10.25 lbs.=4.65 kg.
Width of track shoes.....	8 in.=203 mm.
Tread of tracks (center to center).....	45 in.=1,143 mm.
Diameter of turning circle.....	9 ft.=2.74 meters.
Road speed (per hour):	
Low speed at 2,500 engine revolutions per minute...	5 miles=8.05 km.
Intermediate speed at 2,500 revolutions per minute..	11 miles=17.7 km.
High speed (direct) at 2,500 revolutions per minute..	15 miles=24.15 km.
Reverse speed at 2,500 revolutions per minute.....	4 miles=6.44 km.
Capacity of main gasoline tank.....	20 U. S. gal.=75.7 liters.
Capacity of auxiliary tank, under armor.....	5.75 U. S. gal.=21.8 liters.
Capacity of oil reservoir, engine.....	1.5 U. S. gal.=5.7 liters.
Capacity of speed change transmission gear box.....	3 U. S. gal.=11.4 liters.
Capacity of reduction gear box.....	2.75 U. S. gal.=10.4 liters.
Capacity of two-track oiler tanks, each.....	1 U. S. gal.=3.8 liters.
Brake horsepower of engine at 2,600 revolutions per minute.....	70 H. P.
S. A. E. rating of engine.....	31 H. P.
Drawbar pull (maximum at 2 miles per hour).....	5,000 lbs.=2,268 kg.

#### BRIEF DESCRIPTION.

The 2½-ton Artillery tractor, model of 1917, is a self-propelled road vehicle of the "track-laying" type; that is, the power is transmitted to the ground through a flexible, endless chain or track composed of steel shoelinked together and connected by hardened steel pins instead of through the rear wheels as in the usual type of tuck or tractor construction. The advantage of this type of tractor for military purposes lies in its ability, due to very low unit ground pressure, to negotiate very soft or uneven surfaces, impassable to the usual type of power vehicle except under the most extreme difficulties.

The general design and construction of the 2½-ton Artillery tractor does not differ materially from that of the modern motor truck except for the above-mentioned method of power transmission to the ground, the method of steering, and particularly because it is not designed to carry a load, but only to be employed in the transportation and motorization of Ordnance equipment.

The various units or groups composing the 2½-ton Artillery tractor are assembled on the main frame, which is built up of rolled steel shapes rigidly connected and braced to withstand all stresses. This frame not only supports the units or groups but it holds them in their proper relationship to one another. The main frame, with its assembled units, is supported on the track by means of a roller-frame

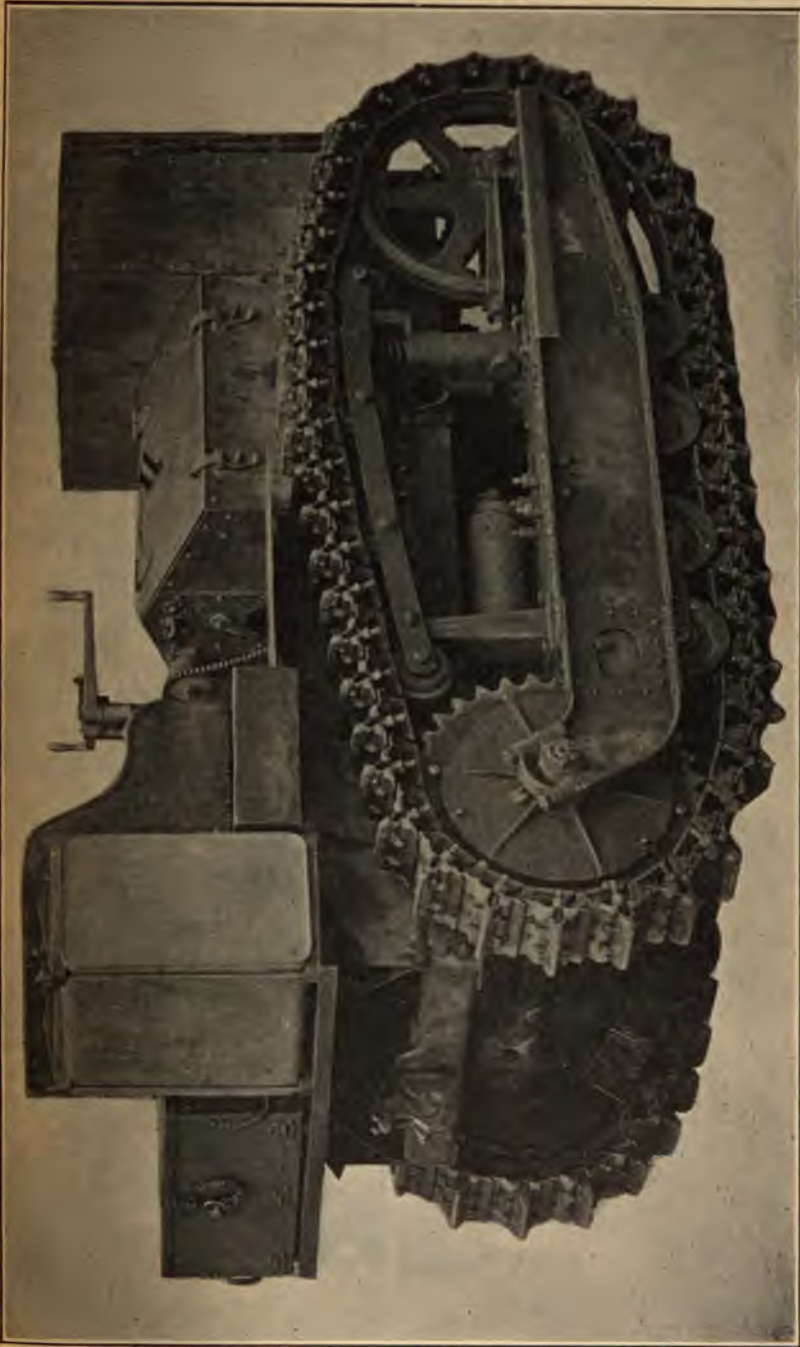

Artillery Tractor, 2½-Ton, Model 1918.

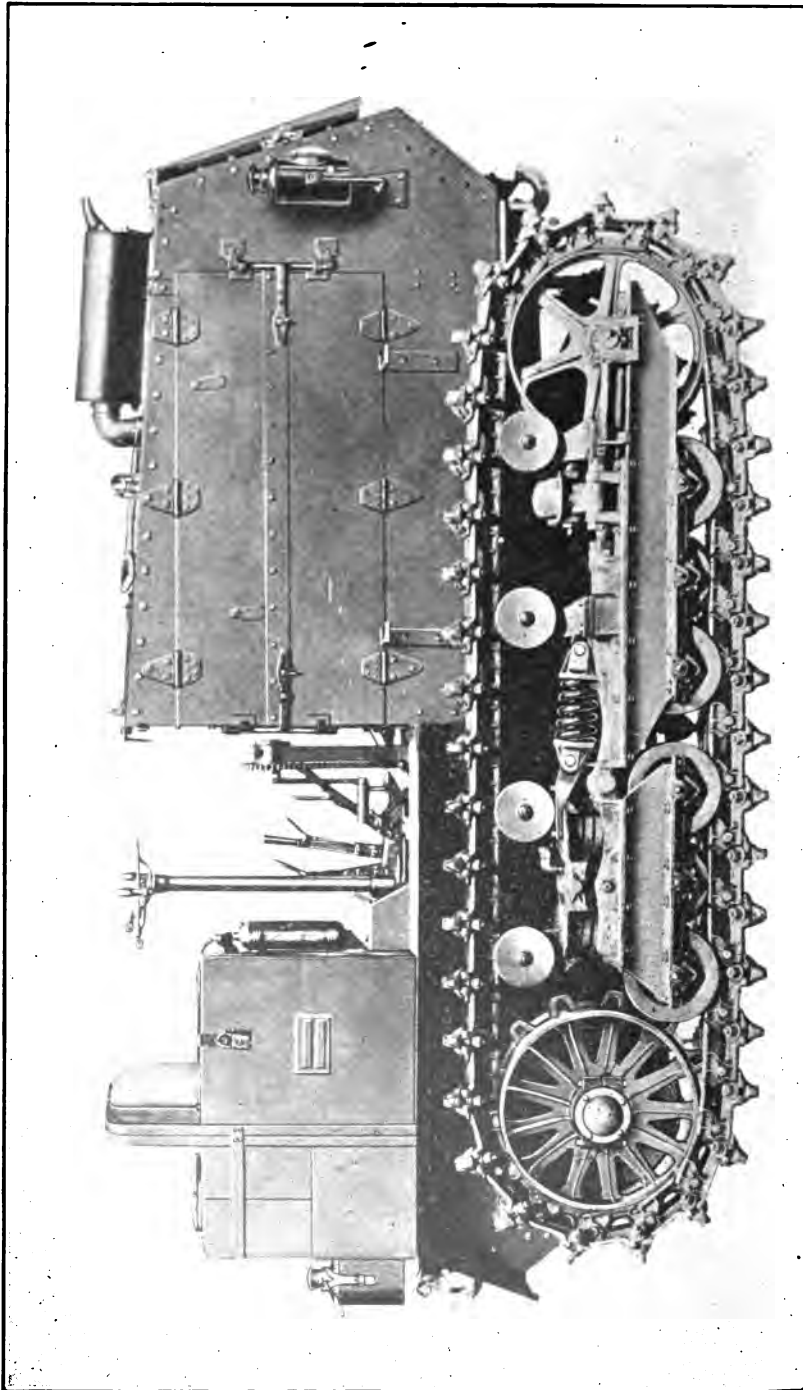

Artillery Tractor, 5-Ton, Model 1917.

assembly on which it rests through the medium of a transversely mounted platform spring in front, and coil springs in the rear.

The power is developed by means of an engine group which consists of an internal combustion engine, using gasoline for fuel, suspended in the forward end of the main frame, a fuel-supply system, an ignition system, lubricating system, and a cooling system.

The power developed in the engine is transmitted to the ground through the medium of a power system, comprising in the following order, a master clutch, controlling the application of power between the engine and the transmission units; a transmission gear box unit, containing the gears by which the speed of the tractor is varied; and a transmission rear drive unit containing the steering clutches, controlling the application of power to either track concurrently or individually; and the track drive sprocket and train of gears, which transmit the power from the steering clutches to the track.

The track is an endless chain consisting of steel links and shoes cast integral and connected by hardened steel track pins. The track shoes are so designed that when assembled the links form a continuous double steel rail on which the track wheels ride; the shoes offering a wide bearing surface to the ground which supports the tractor.

An ordnance pintle, mounted in a special housing attached to the main frame, is supplied at the rear end of the 2½-ton Artillery tractor, and two towing links are fastened to the rear of the rear drive transmission gear housing. Two towing hooks are supplied forward, attached to the main frame.

## ARTILLERY TRACTOR, 5 TON, MODEL OF 1917.

Plate XXXIX.

### WEIGHTS AND DIMENSIONS.

Overall length (armored).....	133.5 in.=3,400 mm.
Overall width.....	63 in.=1,605 mm.
Height (armored, to top of muffler).....	72.5 in.=1,845 mm.
Length of ground contact.....	91 in.=2,315 mm.
Ground clearance.....	11 in.=280 mm.
Weight (complete with full equipment).....	9,200 lb.=4,180 kg.
Ground pressure (9 and 11 inch treads).....	5.6—4.5 lb. per sq. in.= 0.394—0.316 kg. per sq. cm.
Weight of each track.....	545 lb.=548 kg.
Weight of each track shoe (9-inch).....	12 lb.=5.45 kg.
Width of track shoes.....	9—11 in.=299—280 mm.
Tread of tracks (center to center of tracks).....	48.875 in.=1,243 mm.
Diameter of turning circle (overall clearance).....	176 in.=4,425 mm.
Engine, number of cylinders.....	4.
Bore.....	4.75 in.=220.8 mm.
Stroke.....	6 in.=152.5 mm.
Horsepower at 1,200 revolutions per minute.....	56.
Oil reservoir capacity.....	3.25 U. S. gal.=12.22 liters.

**Road speed—gear used (per hour):**

Low speed at 1,200 revolutions per minute of engine..	1.94 miles=3.12 kilos.
Direct speed at 1,200 revolutions per minute of engine.	3.92 miles=6.31 kilos.
High speed at 1,200 revolutions per minute of engine..	7.37 miles=11.85 kilos.
Rev. speed at 1,200 revolutions per minute of engine..	1.41 miles=2.27 kilos.
Capacity of main gasoline tanks (two) combined.....	24 U. S. gal.=90.5 liters.
Capacity of auxiliary tank under armor.....	10 U. S. gal.=37.85 liters.
Capacity of transmission case.....	3 U. S. gal.=11.3 liters.
Capacity of track oiler tank.....	2.5 U. S. gal.=9.43 liters.

**BRIEF DESCRIPTION.**

The 5-ton Artillery tractor, Model 1917, is a self-propelled road vehicle of the "track laying" type; that is, the power is transmitted to the ground through a flexible endless chain which acts as a track and is composed of steel links and shoes cast integral and connected by hardened steel pins. The advantage of this type of tractor as compared with the usual type of wheel tractor or truck is its ability, due to very low unit ground pressure, to negotiate very soft and uneven surfaces, impassable to the usual type of self-propelled vehicle except under the most extreme difficulties.

The general design and construction of the 5-ton tractor does not differ materially from that of the modern truck except in the method of transmitting the power from the transmission unit to the ground. It is used solely as a power vehicle for hauling howitzer carriages and caissons. Each carriage and carriage limber are drawn by one tractor and each pair of caissons are drawn by one tractor.

A complete description and instructions for care, maintenance, and operation are contained in the "Handbook of the 5-Ton Artillery Tractor, Model of 1917." (No. 1996.)

**OUTLINE SPECIFICATIONS.**

**ENGINE.**—Four cylinder, four cycle, valve-in-the-head type. Bore, 4.75 (4 $\frac{1}{4}$ ) inches. Stroke, 6 inches. Cylinders cast in pairs. Horsepower 56 at 1,200 revolutions per minute.

**RADIATOR.**—Honeycomb-tubular type. Eight separate headers.

**IGNITION.**—Eisemann, Model G-4, high tension magneto with automatic impulse starter.

**CARBURETER.**—Model A Schebler carbureter with Stewart vacuum feed system; 1.5 (1 $\frac{1}{2}$ ) inch.

**GOVERNOR.**—Centrifugal flyball type mounted on special shaft and driven off cam-shaft gear.

**MASTER CLUTCH.**—Dry plate multiple disk type.

**TRANSMISSION.**—Selective sliding gear type. Three speeds forward, one reverse. Direct drive on second. Stepped up on high.

**DRIVE.**—From transmission through bevel gears to steering clutch shaft through steering clutches to spur pinions, which mesh with

intermediate spur gears, thence through outside gears, incased, to sprocket drive sleeve and drive sprockets.

**STEERING CLUTCHES.**—Two used of dry plate multiple disk type.

**STEERING.**—By means of steering clutches operated from hand steering device and brake bands operated by foot pedals, which act on outside of steering clutch drums.

**CONTROL.**—Steering gear located on right hand side. Change gear, master clutch operating lever, and brake lever, left of steering gear, left to right, respectively. Spark and throttle levers operate on sector clamped to steering column. Steering clutch pedals right and left at bottom of and in front of steering column.

**BRAKES.**—One set. External contracting type. Raybestos, or equal, lined. Operate on steering clutch housings.

**GASOLINE TANK.**—Terneplate tanks. Two independent duplicate tanks each of 12-gallon capacity. Auxiliary terneplate tank under armor, 10-gallon capacity.

**MAIN FRAME**—Cast in one piece—open hearth steel.

**ROLLER FRAMES.**—Four frames steel channel, joined by oscillating shaft. Two frames right and left front. Two frames right and left rear.

**TRUCK ROLLERS.**—Six on each side tractor, fitted with roller bearings, turning on steel gudgeons, flanged to follow track rail.

**TRACK.**—Made up of malleable iron track shoes with track links integral, fitted with space blocks, and 1.25 (1¼) inch pins.

**TRACK DRIVE SPROCKETS.**—Two. Teeth mesh with opening in tracks.

**BLANK SPROCKETS.**—Two. Fitted with roller bearings which turn on steel gudgeons. Used to adjust track tension.

**TRACK SUPPORTING ROLLERS.**—Four on each side of tractor, two mounted on brackets attached to front roller frame channel, and two in the rear mounted on spring bracket which is bolted to main frame.

**SPRINGS.**—Four double coil springs at rear, two on each side between rear roller frame and bracket on main frame and four—two on each side of equalizing bar—at front.

**EQUALIZING BAR.**—Spring supported on front roller frame sections.

## **AMMUNITION TRUCK.**

(Plate XL.)

The ammunition truck, as supplied to regiments of 155-mm. howitzers, model of 1918, motorized, consists of two units: Ammunition truck body, model of 1918; 2-ton truck chassis, Nash model 4017-A and 4017-L.

Further information concerning those units will be found in the Ordnance Handbooks. "Ammunition truck body, model of 1918" (No. 2002); "2-ton truck chassis, Nash model 4017-A and 4017-L."

## GENERAL WEIGHTS, DIMENSIONS, AND OUTLINE SPECIFICATIONS OF BODY.

Weight of body.....	pounds..	1, 200
Over-all length of body.....	inches..	120
Over-all width of body.....	do.....	56
Over-all height of body.....	do.....	54
Width of floor (inside).....	do.....	43
Length of floor (inside).....	do.....	114
Height of sides (inside).....	do.....	36

## BRIEF DESCRIPTION OF AMMUNITION TRUCK BODY.

The ammunition truck body, model of 1918, consists of a box-type steel body opening only at its rear end. The body is designed to accommodate original packing cases of any type of ammunition. When this vehicle is used near the front lines all four sides and its floor are lined with detachable heavy cocoa matting to prevent undue noise. A tarpaulin cover attaches to the body, and so protects its contents.

In addition to the designation of "ammunition truck," as explained, the ammunition body with various loads is designated when mounted on chassis models as follows: "Wireless," "telephone," "tank," "personnel," "baggage," and "ration."

The chassis and bodies for the above are identical for all purposes. The differences in chassis and body equipment and the load carried when the truck is used for different purposes are noted under tables of equipment on page 162. All of the above bodies are mounted on a 2-ton Nash truck chassis.

## WEIGHTS AND OUTLINE SPECIFICATIONS OF ALL 2-TON CHASSIS, NASH MODELS.

Rated load capacity.....	4, 000.00 lb.=1, 820 kg.
Body weight allowance.....	1, 200.00 lb.=546 kg.
Weight of chassis only.....	6, 700.00 lb.=3, 030 kg.
Maximum gross weight (including chassis, body and pay load).....	11, 900.00 lb.=5, 420 kg.
Percentage of chassis weight on front tires (without load).	66.66 per cent.
Percentage of chassis weight on rear tires (without load).	33.33 per cent.
Percentage of load weight on front tires.....	30.00 per cent.
Percentage of load weight on rear tires.....	70.00 per cent.
Percentage of gross weight on front tires.....	45.00 per cent.
Percentage of gross weight on rear tires.....	55.00 per cent.
Over-all length of chassis (without body).....	202.50 in.=5, 100 mm.
Over-all width of chassis (at widest part).....	78.50 in.=1, 950 mm.
Chassis wheelbase.....	124.00 in.=3, 155 mm.
Length of frame back of driver's seat.....	117.13 in.=2, 980 mm.
Width of frame (outside dimensions).....	38.13 in.=968 mm.
Height of rear end of frame from ground (loaded).....	35.50 in.=890 mm.
Height of rear end of frame from ground (unloaded)....	38.50 in.=980 mm.

Diameter of turning circle.....	50.00 ft.=15.25 meters.
Tread of front wheels.....	60.50 in.=1,540 mm.
Tread of rear wheels.....	60.50 in.=1,540 mm.
Road clearance under front axle (lowest point).....	14.75 in.=374 mm.
Road clearance under rear axle (lowest point).....	14.75 in.=374 mm.

**BRIEF DESCRIPTION, MODELS 4017-A, 4017-L, AND 4017-F.**

The chassis of all of these models is of 124 inches wheel base and is fitted with a Buda model H-U four-cylinder engine, dry disk clutch, four-speed transmission, and a drive to all four wheels through shafts and internal gearing. Although the greater number of units in all three chassis are alike, there are certain structural differences which exist, mainly in the model 4017-F chassis as against the other two. The 4017-F is a two-wheel steer chassis, while the others have four-wheel steering. All of them use four-wheel drive and braking. The models 4017-A and 4017-L are fundamentally the same, differing only in certain details of equipment. Model 4017-L has an acetylene generator and searchlight, and oil side and tail lamps, both speedometer and odometer and an impulse starter on the magneto shaft, while the 4017-A has no impulse starter, uses a Bijur electric generator, storage battery and electric lamps, and is fitted with an odometer only. Aside from the two-wheel steering and the necessary changes brought about by it, models 4017-F and 4017-L are practically the same, though a few slight differences exist in the dash, the brake cross shaft and rods, and the wheel universals as described in detail in Ordnance Handbook No. 1999.

The engine is a standard design L-head, Buda model H-U, using force-feed lubrication, pump cooling, and fitted with a Stromberg carburetor feeding through cored passages in the cylinder block, an Eisemann magneto, and on the model 4017-A only, with a Bijur generator.

The clutch is of the dry-plate type and the drive from it is through an open two-joint propeller shaft to a four-speed, sliding jaw-clutch type transmission. From the latter extend two two-joint propeller shafts, one forward and one rearward, to internal gear-drive axles. The live member has exposed axle shafts extending from it, and the ends of these shafts are each fitted with a universal joint and a spur pinion, the latter meshing with an internal gear bolted to a disk steel wheel. All the wheels are interchangeable and are all driving and steering wheels in models 4017-A and 4017-L, while in the model 4017-F only the front wheels steer.

A complete description of the 2-ton truck chassis, models 4017-A, 4017-L, and 4017-F, with instructions for care, maintenance, and operation, is given in the "Handbook of the 2-ton Chassis Nash Models 4017-A, 4017-L, and 4017-F," Ordnance Pamphlet No. 1999.

**ANTI-AIRCRAFT MACHINE-GUN TRAILER.**

(Plate XXXV.)

**PRINCIPAL DIMENSIONS AND OUTLINE SPECIFICATIONS.**

Capacity.....	1½ ton=1,530 kg.
Wheel base.....	74.625 in.=1,900 mm.
Width of track.....	56 in.=1,428 mm.
Width of frame.....	37 in.=943 mm.
Length of frame.....	120 in.=3,055 mm.
Diameter of wheels.....	32 in.=816 mm.
Tire size.....	32 x 3 in.=816 x 76.5 mm.
Front springs.....	42 x 2½ in.=7 leaves semielliptic.
Rear springs.....	42 x 2½ in.=8 leaves semielliptic.
Axle bearings.....	Bock No. 307 and No. 308 taper roller bearings.
Drawbar length.....	45.5 in.=1,160 mm.
Width of body over all.....	47.5 in.=1,210 mm.
Length of body over all.....	123.5 in.=3,130 mm.
Depth of body.....	12 in.=306 mm.
Floor.....	Oak.

**GENERAL DESCRIPTION.**

The antiaircraft machine-gun trailer body, mounted on the 1½-ton trailer chassis, is used to carry two machine guns, with two mounts, and the necessary spare parts and ammunition for these guns. In addition, various tools, namely, pick, shovel, ax, hatchet, etc., are carried on the outside of the body.

The cygnet type of gun mount is located in the rear end of the body, while the tripod mount is at the front end, these mounts being interchangeable.

Each mount will be equipped with four adapters, affording means for mounting either the Browning and Vickers machine gun, the Marlin tank and Marlin aircraft machine gun, the Hotchkiss machine gun, or the Browning automatic rifle.

The spare-parts chest, located in the center of the body, contains spare parts for the two Browning machine guns. On each side of the spare-parts chest and running crosswise of the body are the two gun chests, which contain the guns when they are not mounted on the mounts. The ammunition boxes are placed under the spare-parts and gun chests.

The trailer body is made of oak, and is substantially braced by corner angles and side braces. The floor of the body is made of oak and bolts to a heavy longitudinal oak sill which rests on the channel frame of the trailer chassis.

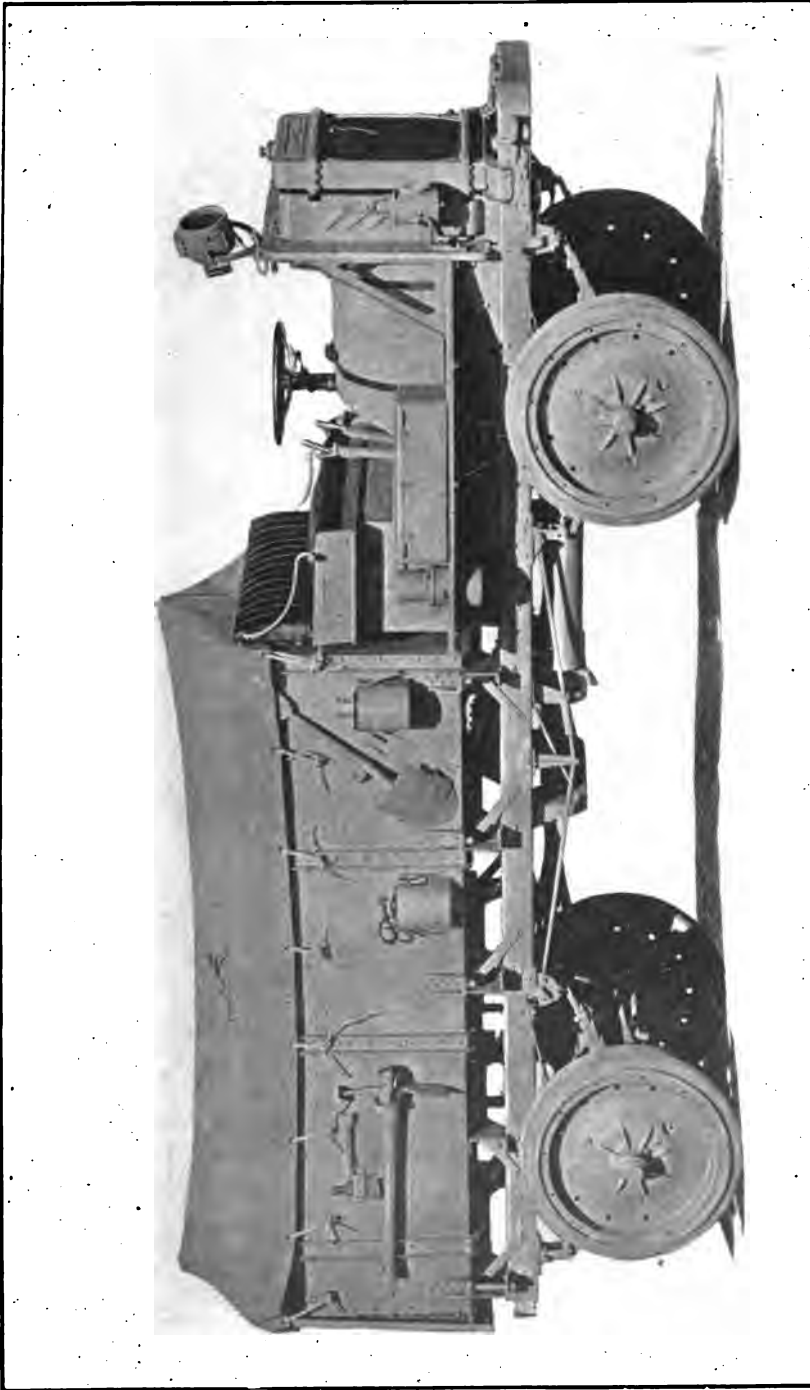

**Ammunition Truck, 2-Ton.**

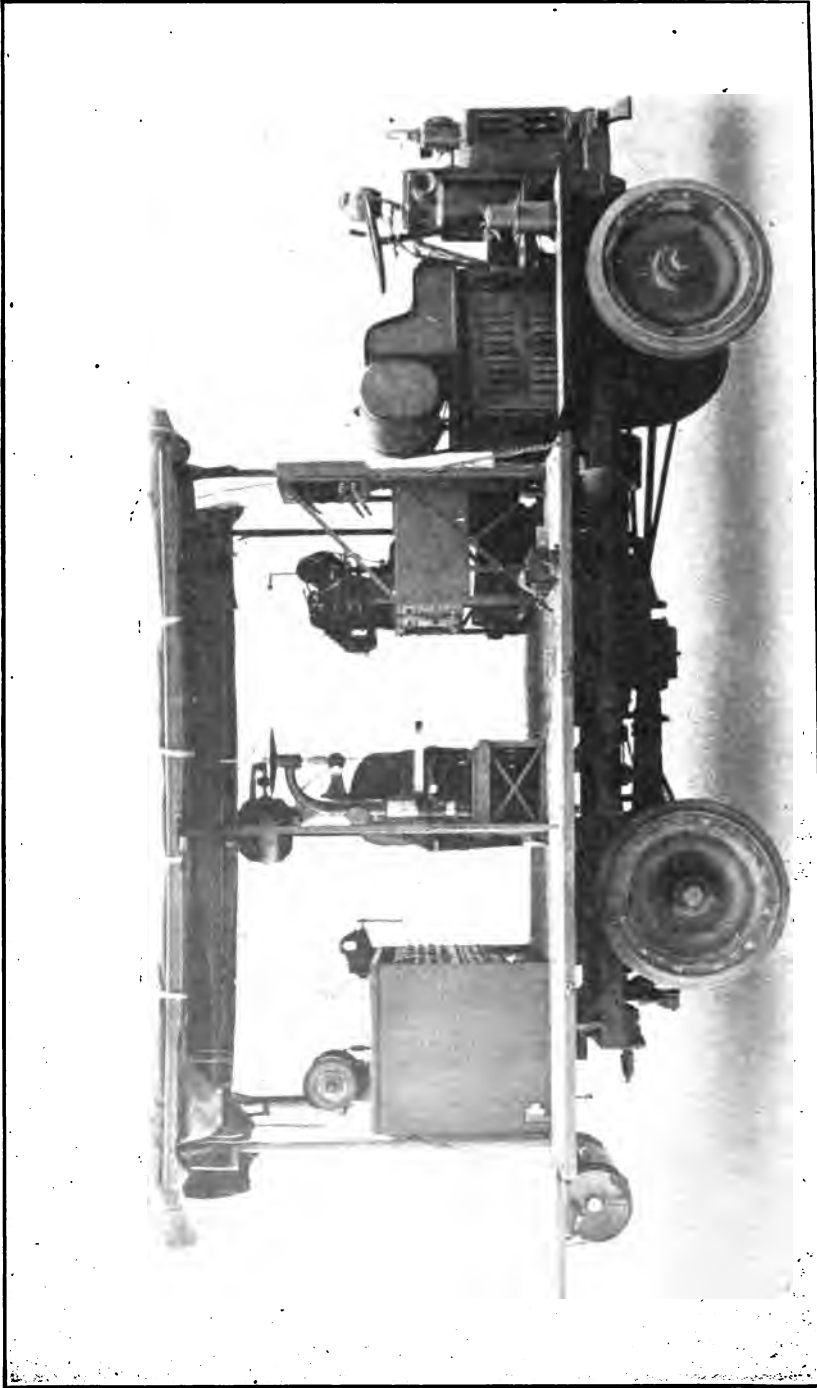

Artillery Repair Truck.

The trailer chassis is of standard design, with the conventional side channel frame, angular cross members, semielliptic springs, and standard draw bar.

Steering is accomplished in the usual manner, the drawbar transmitting the motion through a drag link to the tie-rod and then to the wheel spindles.

Both front and rear springs are fixed at their front ends, being free to move at the other end.

A standard coupling is fastened to the end of the chassis frame and is used for attaching other trailers or vehicles.

Lubrication of the trailer parts is furnished by grease cups placed at the different wearing surfaces.

Grease cups are placed at the ends of each spring bolt, at each of the front-wheel spindles, and at the two ends of the drag link.

A complete description of the antiaircraft machine-gun trailer, with directions for care and maintenance, is contained in "The Handbook of the Antiaircraft Machine Gun Trailer," Ordnance Pamphlet No. 1980.

## ARTILLERY REPAIR TRUCK.

(Plate XLI.)

The artillery repair truck, as issued to sectors of 3-inch antiaircraft guns, model of 1918, motorized, consists of two units:

Artillery repair truck, model of 1918.

Two-ton truck chassis, Nash model.

Further information concerning these units will be found in Ordnance handbooks: "Artillery Repair Truck Body, Model of 1918" (No. 1962). "Two-ton Truck Chassis, Nash Model" (No. 1999).

### WEIGHTS AND SPECIFICATIONS.

Weight of body empty.....	3,060 lb.=1,393 kg.
Weight of body with full load.....	7,040 lb.=3,200 kg.
Length of platform.....	132 $\frac{3}{4}$ in.=3,380 mm.
Length with drop end down.....	156 $\frac{3}{4}$ in.=3,990 mm.
Width of body platform.....	71 $\frac{1}{4}$ in.=1,825 mm.
Width with drop sides down.....	119 $\frac{1}{4}$ in.=3,040 mm.
Height of drop sides.....	24 in.=610 mm.
Height of drop end.....	24 in.=610 mm.
Chassis used.....	Nash 2-tons or F. W. D. 3-ton.
Floor material.....	Poplar, 1 $\frac{1}{4}$ in. thick =38.5 mm.

### GENERAL DESCRIPTION.

#### CHASSIS.

The chassis unit of the artillery repair truck is identical in all respects, including equipment, with the chassis unit of the ammunition truck. (See under heading "Ammunition truck.")

## BODY.

The body of the artillery repair truck, model of 1918, is of the drop-side, drop-gate type. Both the sides and the gate when dropped are held level with the floor of the truck by chains. Hence they can be readily used as workbenches when the body is put in working position. Provision is made for the attachment of body equipment tools to the outside of the drop sides. A vise is bolted to the rear end of the right drop side. A compressed-air tank, 14 inches in diameter by 48 inches long, is affixed to the drop gate, being supported by cradles and metal straps.

The body is completely roofed, but the entire roof can be raised or lowered at will. Both ends of the truck are inclosed by drop curtains, which, as well as the tarpaulin, can be rolled up when not in use.

Slung under the floor near the front of the body, on both sides, but clear of the chassis frame, are an oxygen tank (right side, 9 by 33 inches) and an acetylene tank (left side, 12 by 33 inches). The steel floor box which extends below the floor of the body is used to carry various small tools and accessories.

Since the truck carries electrically operated machinery and is electric lighted, a system of conduits for the protection of the necessary wiring is incorporated on the floor of the truck, so that the power generated by the machinery provided for the purpose can be conveyed to units not on the truck; the body is equipped with an adequate number of outlet sockets.

**BENCH CABINET.**—This cabinet is made in two sections. In the front section there are 15 drawers in which are carried an assortment of hand and precision tools. The rear half of the cabinet is divided horizontally into two storage compartments of equal size. The top of this cabinet is used as a workbench and has bolted to it a large bench vise and an electrical motor-driven bench grinder.

**GENERATOR.**—The electric power necessary to light the truck and operate the machinery with which it is equipped is generated by a 4-kilowatt engine generator unit centrally located on the body.

**LATHE.**—At the front of the body there is placed a No. 9 star screw-cutting engine lathe. This lathe is provided with a milling attachment and is belt driven from an electric motor.

**RIVETING HAMMER.**—An air-riveting hammer is furnished. This hammer has a piston diameter of 1.125 inches and a stroke of 3 inches. The hammer delivers about 2,400 blows per minute and utilizes 13 cubic feet of free air per minute. It requires one-fourth-inch hose connection. The total weight of outfit is about 14.5 pounds, while its over-all length is 15.5 inches.

**AIR COMPRESSOR.**—To supply the compressed air for the hammer just mentioned the truck is provided with a portable air-compressor

unit mounted on skids. The compressor is belt driven from 1½-horsepower compound wound motor, the belt of which is kept tight by means of a spring idler.

**DRILL PRESS.**—A sensitive drill press bench type outfit is placed on the left of the body, adjacent to the engine generator unit. This press will drill holes up to five-eighths inch in diameter.

**POST TOOL GRINDER.**—The truck is equipped with a portable post tool grinder and is especially adapted for grinding lathe centers, cutters, reamers, rolls, etc., and for surface parallel and internal grinding jobs of all kinds. The machine can be clamped in a vise for bench work.

**WELDING OUTFIT.**—An oxyacetylene welding and cutting outfit is also furnished. This outfit is packed and carried in two steel carrying cases; both the welding and cutting torches are constructed so as to permit the mixing of both oxygen and acetylene in an interchangeable tip. The cutting torch is of the two-hose type. Both oxygen and acetylene are carried in tanks located one on either side of the truck.

**BENCH GRINDER.**—Bolted to the rear of the bench cabinet there is a bench grinder, 110-volt direct current one-half horsepower. It carries two 10 by 1 inch alundum wheels. Its weight approximates 100 pounds, while it runs at from 2,100 to 3,000 revolutions per minute.

## **ARTILLERY SUPPLY TRUCK.**

(Plate XLII.)

The artillery supply truck with loads A, as issued to regiments of 155-mm. howitzer, model of 1918, motorized, consists of two units: Artillery supply truck body, model of 1918.

Two-ton truck chassis, Nash model.

Further information concerning these units will be found in Ordnance handbooks: "Artillery Supply Body, Model of 1918" (No. 2004), "Two-ton Truck Chassis, Nash Model" (No. 1999).

### GENERAL WEIGHTS AND DIMENSIONS.

Weight of body.....	1, 200 pounds.
Over-all length of body.....	122 inches.
Over-all width of body.....	55. 5 inches.
Height of body.....	51 inches.

### BRIEF DESCRIPTION.

#### CHASSIS.

The 2-ton truck chassis, Nash model, used as one of the units of the artillery supply truck, is identical in all respects, including equipment, with the chassis of the ammunition truck. (See description, etc., of chassis under heading "Ammunition truck.")

## BODY.

The artillery supply body is made of steel and has drop sides. These when lowered are kept level with the floor of the truck by chains, and can be used as work benches.

A large bench chest (an integral part of the body) is provided at the rear of the truck. It is used for the storage and carriage of small chests, such as the grindstone, carpenter's chest, etc.

Entrance to the bench chest is secured by means of a door at its rear. A floor locker for the carriage of sundry small supplies is provided. Means for the convenient carriage of three spare artillery wheels is also furnished; two fasten to the sides of the truck and one lies on the floor. Over this last-mentioned wheel there is placed a supporting frame for supply chests.

## LOADS.

The artillery supply body consists of a floor incorporating two steel boxes, a rigid front plate, two hinged sides, and a bench chest, the latter being mounted permanently at the rear of the floor and extending higher than the body sides. The space between the bench chest and the front of the truck body is used to carry removable steel chests, the number and contents depending on the service for which the truck is intended. Thus, the body incorporates three chests (bench chest and two floor boxes), and also carries removable chests. The latter are called by the following names:

Forge chest.  
Supply chest.

Spring chest.  
Fluid chest.

Thus, the complete load a truck will bear will consist of any or all of the four chests named above, or any combination of them, in addition to the bench chest and floor boxes with which every truck is fitted. The bench chest itself carries certain wooden chests, the number depending on the load of the truck.

In addition to the standard body equipment fastened to the outside of the body with which each artillery supply body is equipped, one of the following loads is carried by each. Each load consists of a number of steel chests and the various equipment and parts carried in them.

Load A: Cleaning and preserving materials, and spare parts for artillery material. Assigned to motorized batteries.

Load B: Spare parts for F. W. D. 3-ton trucks. Assigned to supply company of motorized regiments.

Load C: Spare parts for optical instruments, telephones, fire-control instruments, etc. Assigned to headquarters company of motorized regiments.



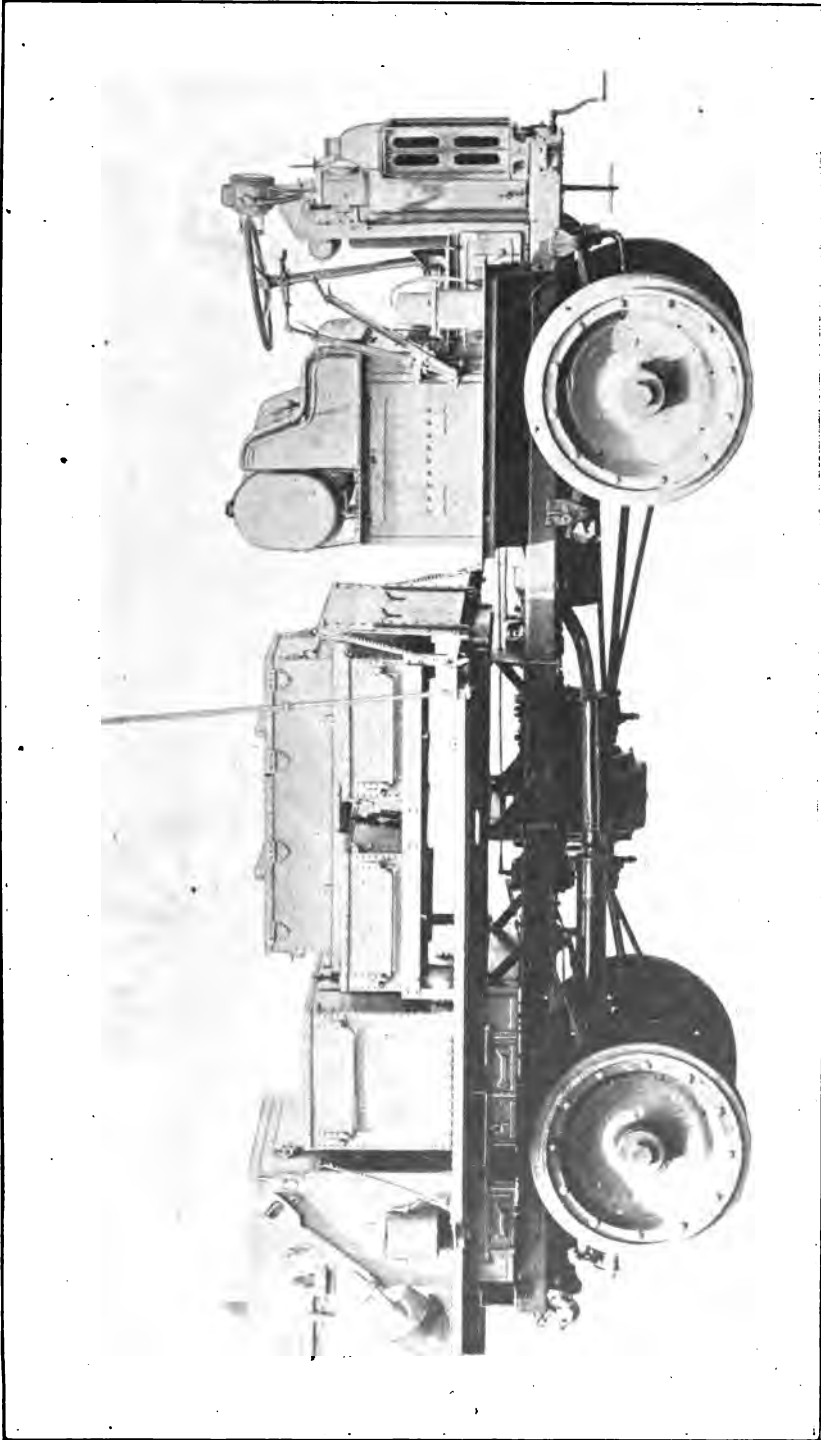

Artillery Supply Truck, 2-Ton.

PLATE XLIII

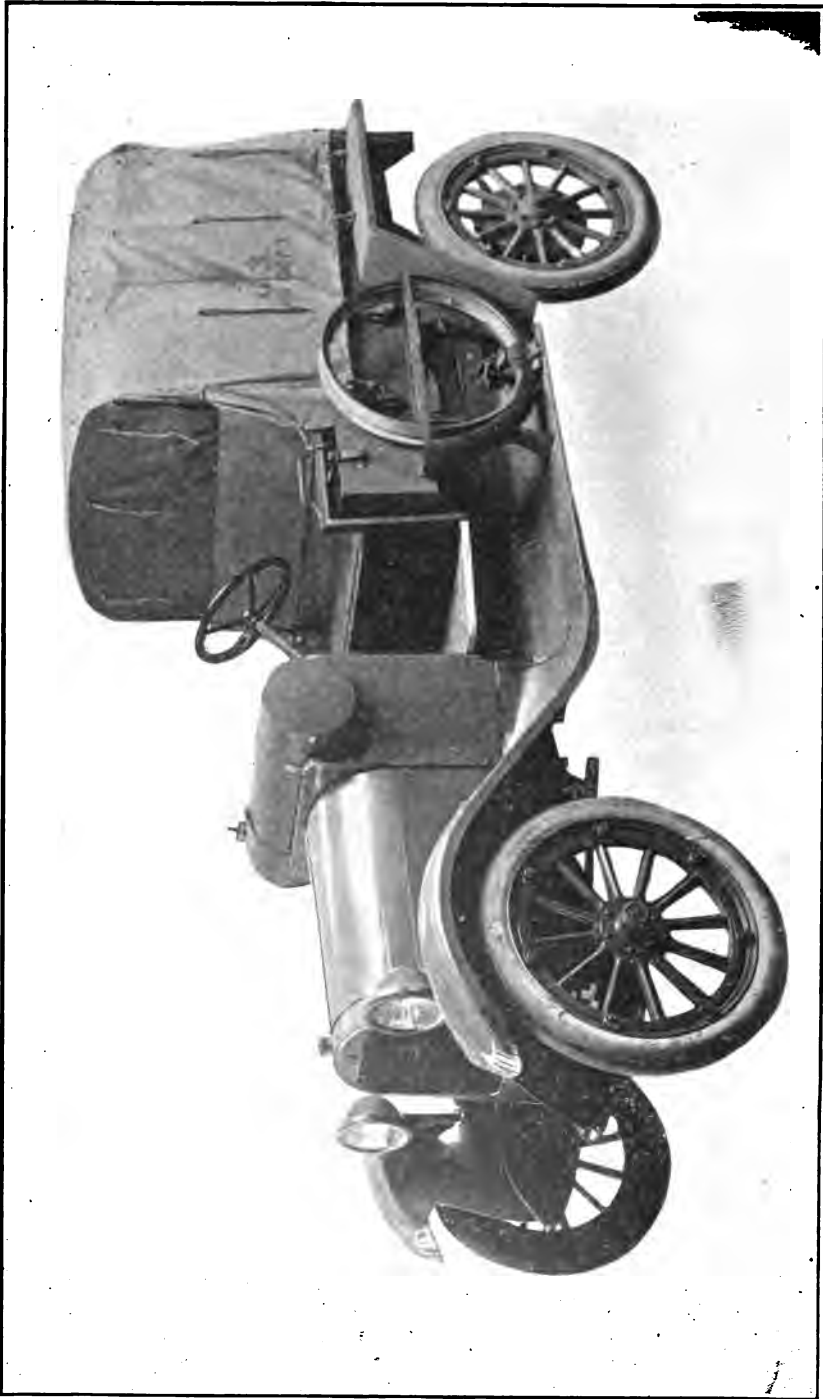

Light Repair Truck.

Load D: Raw material, bar stock, etc. Assigned to and accompanying artillery repair trucks. When operating in a divisional mobile repair shop a special equipment will be carried in addition to regular load D.

### LIGHT REPAIR TRUCK, MODEL OF 1918.

(Plate XLIII.)

#### WEIGHTS, DIMENSIONS, ETC.

Rated load capacity.....	1,000 lb.=455 kg.
Body weight (complete).....	613 lb.=289 kg.
Weight of chassis.....	1,725 lb.=455 kg.
Maximum gross weight loaded.....	3,610 lb.=1,640 kg.
Chassis weight on front tires (without load).....	59 per cent.
Chassis weight on rear tires (without load).....	41 per cent.
Load weight on front tires.....	29.7 per cent.
Load weight on rear tires.....	70.3 per cent.
Load gross weight on front tires.....	31.1 per cent.
Load gross weight on rear tires.....	68.9 per cent.
Overall length of chassis (without body) inches.....	153.06 in.=3,890 mm.
Overall width of chassis at widest part.....	65 in.=1,650 mm.
Chassis wheel base.....	113.18 in.=2,870 mm.
Length of frame back of driver's seat.....	47.37 in.=1,205 mm.
Width of frame (outside dimensions).....	38 in.=965 mm.
Height of rear end of frame from ground (empty).....	31.75 in.=805 mm.
Diameter of turning circle.....	40 ft.=12.2 meters.
Tread of rear wheels.....	56 in.=1,425 mm.
Road clearance under front axle (lowest part).....	11 in.=280 mm.
Road clearance under rear axle (lowest part).....	10.68 in.=272 mm.
Engine, number of cylinders.....	4
Bore.....	3.875 in.=98.5 mm.
Stroke.....	4.5 in.=114.5 mm.
Piston displacement.....	212.5 cu. in.=1,370 cu. cm.
Horse power, rated.....	24.03

#### BRIEF DESCRIPTION OF CHASSIS, DODGE LAYOUT NO. 9017.

**ENGINE.**—Four-cylinder, four-cycle type, L-head cylinders cast in block. Bore 3.875 ( $3\frac{7}{8}$ ) inches, stroke 4.50 ( $4\frac{1}{2}$ ) inches, displacement 212.5 ( $212\frac{1}{2}$ ) cubic inches, 24.03 horsepower, N. A. C. C. formula.

**COOLING.**—Centrifugal pump water circulation.

**RADIATOR.**—Tubular type, with cooling fins, separate shell and core.

**OILING.**—Constant level circulating splash system.

**IGNITION.**—Eisemann high tension, type G-4, second edition magneto.

**CARBURETER.**—Model 25, 1-inch Stewart with hot-air connection.

**FUEL FEED.**—Gravity. From tank located back of driver's seat.

**CLUTCH.**—Multiple disk dry plate.

**TRANSMISSION.**—Selective sliding gear type, three speeds forward and one reverse.

**DRIVE.**—Shaft drive from transmission through one universal joint to bevel gears in the rear axle.

**PROPULSION.**—Through rear springs, Hotchkiss drive.

**FRAME.**—Channel section pressed steel. Three cross members.

**SPRINGS.**—Front—Semielliptical 35.812 ( $35\frac{1}{4}$ ) inches long, 1.75 ( $1\frac{3}{4}$ ) inches wide. Rear—three-quarter elliptical. Lower 43 inches long, 2 inches wide, eight leaves. Upper, 17.25 ( $17\frac{1}{4}$ ) inches long, 2 inches wide, seven leaves.

**AXLES.**—Rear—Internal shaft, full floating type. Incorporating bevel pinion and ring gear and bevel pinion type differential. Front—I-beam section drop forging, heat treated chrome vanadium steel, adjustable tie-rod, steering knuckles and arms bushed, lubricated by grease and oil cups. Wheel hubs fitted with roller bearings.

**BRAKES.**—Two sets: Pedal-operated service brake, external contracting on brake drum; hand lever operated emergency brake, internal expansion on rear wheel brake drums.

**TIRES.**—33 by 4 inches, pneumatic.

**STEERING.**—Front wheels only used for steering. Steering gear of the worm and wheel type; 17-inch diameter hardwood steering wheel.

**CONTROLS.**—Left hand steering gear, with shift and emergency brake levers at right of driver's seat. Spark and throttle control levers mounted on sector located on right side of steering column beneath the steering wheel. Ignition ground wire switch located on instrument board. Accelerator pedal located on upper toe board. Clutch and brake pedals are located left to right respectively.

#### BRIEF DESCRIPTION OF LIGHT REPAIR TRUCK BODY.

The light repair truck is provided with a light repair truck body, model 1918, mounted upon a commercial car chassis, Dodge layout No. 9017. The body is divided into a front compartment, which has a single seat, and a rear compartment, which is used for trucking purposes, closed by a tail gate or door. The front seat is wide enough to comfortably seat three passengers, including the driver. This is protected by a folding top and side curtains, while the truck portion is covered by the paulin provided. The rear part of the body has the following inside measurements: Length, from back of the seat to the tail gate or door, 62.5 ( $62\frac{1}{2}$ ) inches; width, inside of side plates, 46 inches; maximum height, between body floor and underside of paulin supporting bows, 48 inches.

The light repair truck body, model 1918, is made entirely of steel and mounted upon the frame by means of five transverse channel steel transoms and two longitudinal channels which level up the framework upon which the body rests. This is made necessary by the kick-up, which is standard construction in the chassis frame.

The body is without doors or seat cushion, the paulin, when not in use, being employed for the latter. On each side of the dash or cowl there is placed an oil lamp and upon a bracket fastened to the instrument board, also on the cowl, is mounted a standard acetylene searchlight.

The body carries a complete repair equipment of machine and carpenter tools, a mechanic's vise which can be attached to the tail gate and a 2-ton block and tackle. In addition there are chests in which repair parts and emergency lubricants are carried.

The chassis is very little different from the passenger car chassis made by Dodge Bros. It carries a four-cylinder block cast motor, to which is attached a three-speed selective transmission, thus forming a unit power plant. A multiple disk clutch transmits the power from the engine to the transmission. An I-beam front axle and a full floating rear are standard construction. The springs are semi-elliptical in front and three-quarter in the rear. A single universal joint and a propeller shaft inclosed by a tubular torque tube are used. Cooling is obtained with a tubular radiator assisted by a centrifugal water pump and a six-bladed pressed steel fan. Both brakes are operated on drums attached to the rear wheels, the foot brake acting on the outside and the hand on the inside of the drums. Further information concerning this unit will be found in Ordnance Handbook No. 2007.

### THE REEL, MODEL OF 1909 M1.

(Plate XLIV.)

#### WEIGHTS AND PRINCIPAL DIMENSIONS.

Weight without equipment, unloaded.....	636 kg.=1,402 lb.
Weight completely equipped and loaded.....	842 kg.=1,855 lb.
Weight of reel and cart both equipped and loaded.....	1,757 kg.=3,873 lb.
Diameter of wheels.....	1,422 mm.=56 in.
Width of track.....	1,524 mm.=60 in.
Free height under vehicle.....	483 mm.=19 in.
Length of wire carried.....	12,875 meters=14,080 yd.
Turning angle with cart limbered.....	75°.

#### NOMENCLATURE OF THE REEL.

(Property classification, Class IV, Division 3.)

The battery personnel is directed to use the following nomenclature, giving piece marks and drawing numbers, when referring to parts of the reel in reports, correspondence, etc.

Number.	Name of part.	Drawing.	Piece mark.
1	Automatic pole support, pintle, complete, consisting of—		
1	Headless screw.....	13-27-10	10B.
1	Spring cap.....	13-27-10	10A.
1	Spring cap holder.....	13-27-10	10D.
2	Trunnion bolts.....	13-27-10	10C.
2	Steel pins.....	13-27-11	
1	Pintle bearing bracket.....	13-27-11	11D.
1	Pintle bearing.....	13-27-11	11B.
1	Spring yoke.....	13-27-11	11A.
1	Pintle bearing spring.....	15-2KA-13	AB13B.
1	Pintle latch.....	15-2KA-53	AB53A.
1	Pintle latch pin.....	15-2KA-53	AB53B.
1	Pintle nut.....	15-2KA-13	AB13D.
1	Pintle latch spring.....	15-2KA-19	AB19C.
1	Pintle.....	15-2KA-10	AB10A.
1	Sleeve.....	15-2KA-12	AB12G.
1	Split pin.....	15-2KA-13	
1	Axle, complete, consisting of—		
1	Bracket (right).....	13-27-4	4A.
1	Bracket (left).....	13-27-4	4B.
1	Bracket cap (right).....	15-2KA-34	AB34F.
1	Bracket cap (left).....	15-2KA-34	AB34A.
4	Bracket cap bolt.....	15-2KA-34	AB34B.
2	Do.....	15-2KA-34	AB34D.
2	Do.....	15-2KA-34	AB34C.
1	Bracket hub.....	15-2KA-42	AB42A.
1	Bracket hub bushing.....	15-2KA-42	AB42B.
1	Bracket retainer.....	15-2KA-38	AB38A.
4	Bracket retainer bolt.....	15-2KA-38	AB38B.
2	Do.....	15-2KA-38	AB38C.
2	Arm.....	15-2KP-20	PB20A.
2	Arm plug.....	15-2KP-20	PB20B.
4	Cover plate.....	15-2KA-42	AB42C.
2	Dowels, steel.....	13-27-4	
1	Drum axle.....	13-27-3	3C.
2	Pins, 0.375 by 3.5 in.....	13-27-4	
3	Screw steel.....	13-27-3	3G.
1	Stopper (for drum shaft).....	13-27-3	3D.
1	Stopper.....	15-2KA-34	AB34K.
1	Washer.....	13-27-3	3E.
1	Clutch complete (left drum), consisting of—		
1	Clutch rod.....	13-27-18	18C.
1	Clutch rod washer.....	13-27-20	20A.
1	Intermediate washer.....	13-27-20	20B.
1	Clutch rod guide.....	13-27-20	20C.
1	Clutch rod spring.....	13-27-20	20D.
1	Clutch rod handle.....	15-2KM-10	M10B.
1	Clutch, complete (right drum), consisting of—		
1	Sprocket ring.....	15-2KA-36	AB36A.
1	Sprocket ring bushing.....	15-2KA-36	AB36B.
1	Drum sprocket.....	15-2KA-36	AB36C.
4	Drum sprocket screws.....	15-2KA-36	AB36D.
1	Friction disk bushing.....	15-2KA-36	AB36E.
1	Friction disk.....	15-2KA-36	AB36F.
2	Sliding keys.....	15-2KA-36	AB36G.
1	Screw.....	15-2KA-36	AB36H.
1	Relief spring.....	15-2KA-36	AB36K.
1	Adjusting ring.....	15-2KA-36	AB36L.
1	Filler ring.....	15-2KA-36	AB36M.
1	Clutch spider.....	15-2KA-36	AB36N.
12	Toggle links.....	15-2KA-36	AB36P.
3	Link pins (for clutch spider).....	15-2KA-36	AB36Q.
3	Link pins (for toggle links).....	15-2KA-36	AB36R.
6	Do.....	15-2KA-36	AB36S.
3	Adjusting ring locks.....	15-2KA-36	AB36T.
3	Adjusting ring lock screw.....	15-2KA-36	AB36V.
3	Radial links.....	15-2KA-36	AB36W.
1	Oiler clip.....	15-2KA-37	AB37A.
2	Machine screws.....	15-2KA-37	AB37B.
1	Handwheel spindle.....	15-2KA-37	AB37C.
1	Hub bearing.....	15-2KA-37	AB37D.
1	Standard tube.....	15-2KA-37	AB37E.
1	Standard support.....	15-2KA-37	AB37F.
1	Support bushing.....	15-2KA-37	AB37G.
1	Handwheel shaft.....	15-2KA-37	AB37H.
1	Shaft bevel pinion.....	15-2KA-37	AB37K.
1	Sleeve bevel gear.....	15-2KA-37	AB37L.
1	Felt washer.....	15-2KA-37	AB37M.
1	Tube brass.....	15-2KA-37	AB37N.
1	Screw.....	15-2KA-37	AB37P.
1	Bronze body.....	15-2KA-37	AB37Q.
1	Handwheel hub.....	15-2KF-4	F. B4C.
1	Handwheel plate.....	15-2KF-4	FB4A.
1	Handwheel rim.....	15-2KF-4	FB4B.
2	Dowels.....	15-2KA-36	
1	Oil hole cover.....	15-2KA-37	

Number.	Name of part.	Drawing.	Piece mark
	Clutch, complete (right drum), consisting of—Continued.		
1	Pin, 0.375 by 3.5 inches	15-2KA-36	
4	Split pins, 0.25 by 1.25 inches	15-2KA-40	
3	Toggle brackets	13-27-18	18D.
1	Connecting pole, complete, consisting of—		
1	Butt reinforce	15-2KL-3	LB3F.
1	Pin, 0.25 by 0.5 inch	13-27-15	
1	Lunette	15-2KA-9	AB9A.
1	Lunette bearing	15-2KL-18	LB18B.
2	Lunette pin	15-2KL-18	LB18C.
1	Neck yoke chafing plate	15-2KL-3	LB3A.
1	Neck yoke counter stop	15-2KL-12	LB12B.
1	Neck yoke counter stop pin	15-2KL-12	LB12D.
1	Neck yoke counter stop spring	15-2KL-12	LB12C.
1	Neck yoke stop	15-2KL-12	LB12A.
1	Pole body	15-2KL-3	LB3F.
1	Pole socket	13-27-15	15A.
1	Pole bracket strap	13-27-17	17C.
1	Pole clamp bolt	13-27-15	15B.
1	Pole pin	15-2KL-11	LB11C.
1	Pole pin bushing	15-2KL-3	LB3D.
1	Pole plug	15-2KL-12	LB12E.
1	Connecting pole brackets, complete, consisting of—		
1	Connecting pole bracket (front)	13-27-17	17A.
1	Connecting pole bracket (rear)	13-27-17	17D.
1	Connecting pole retainer	13-27-17	17B.
1	Connecting pole body	15-2KL-17	LB17A.
1	Connecting pole key	15-2KL-11	LB11D.
1	Crown nut, 0.75 inch		
1	Crown nut, 0.5 inch		
1	Dowel, 0.25 by 1.375 inches		
1	Pole bracket strap	13-27-17	17C.
1	Pin, type A	13-27-17	17G.
1	Do	13-27-17	17F.
1	Swing bolt	13-27-17	17E.
1	Washer	13-27-17	
1	Split pin, $\frac{1}{8}$ by 1	13-27-17	
1	Doubletree, complete, consisting of—		
2	Chain	15-2KL-9	LB9X.
1	Doubletree bolt	15-2KL-11	LB11K.
1	Doubletree body	15-2KL-11	LB5D.
1	Doubletree strap	13-27-16	16C.
2	Filler pieces	13-27-24	24C.
1	Staple (doubletree)	13-27-24	24E.
1	Separator (doubletree)	15-2KA-38	AB38F.
1	Separator (doubletree strap)	13-27-16	16D.
1	Drum (right), complete, consisting of—		
1	Drum body	13-27-19	19B.
1	Drum head	13-27-3	3A.
1	Intermediate drum head	13-27-18	18A.
1	Drum end plate	15-2KE-62	E B62A.
1	Drum (left), complete, consisting of—		
1	Drum body	13-27-19	19A.
1	Drum head	13-27-3	3B.
1	Intermediate drum head	13-27-18	18B.
3	Drum end plate	15-2KE-62	E B62B.
1	Wire clamp (female half)	15-2KA-35	A B35A.
1	Wire clamp (male half)	15-2KA-35	A B35B.
2	Block bolts	15-2KA-35	A B35C.
1	Binding post block	15-2KA-35	A B35D.
2	Telephone connections	15-2KA-35	A B35E.
2	Binding posts	15-2KA-35	A B35F.
1	Wire clamp bolt	15-2KA-35	A B35G.
4	Washers	15-2KA-35	A B35H.
4	Crown nuts, 0.25 inch	15-2KA-35	
1	Crown nuts, 0.375 inch	15-2KA-35	
4	Split pins	15-2KA-35	
1	Drum brake, consisting of—		
1	Brake rod end	13-27-21	21D.
1	Brake rod	13-27-21	21A.
1	Brake rod spring	13-27-21	21H.
1	Foot lever	13-27-21	21B.
1	Spring stop	13-27-21	21F.
1	Pin	13-27-21	21G.
1	Do	13-27-21	21K.
1	Brake lever	13-27-22	22A.
1	Brake lever bracket	13-27-22	22D.
1	Brake lever pin	13-27-22	22G.
1	Brake shoe	13-27-22	22F.
1	Foot lever bracket	13-27-22	22B.
2	Bolts, 0.375 by 0.963 inch	13-27-22	22C.
1	Leather, hard sole	13-27-22	22E.
1	Pin, type A	13-27-21	21E.
1	Do	13-27-21	21C.

Number.	Name of part.	Drawing.	Piece mark.
	<b>Drum brake, consisting of—Continued.</b>		
2	Nuts, 0.375 inch.....	13-27-22	
1	Pin.....	13-27-21	21G.
1	Do.....	13-27-21	21K.
2	Washers, 0.375 inch.....	13-27-22	
1	<b>Drum driving gear, consisting of—</b>		
1	Chain, 67.5 inches long.....	15-2KA-40	AB40D.
1	Chain, 69.75 inches long.....	15-2KA-40	AB40E.
1	Chain tightener.....	15-2KA-40	AB40L.
2	Bolts, 0.5 by 2.812 inches.....	15-2KA-40	AB40H.
2	Bolts, 0.5 by 3.781 inches.....	15-2KA-40	AB40K.
1	Jack shaft sprocket (outer).....	15-2KA-40	AB40A.
1	Jack shaft nut.....	15-2KA-40	AB40C.
1	Jack shaft.....	15-2KA-40	AB40E.
1	Jack shaft frame.....	15-2KA-40	AB40G.
4	Crown nuts, 0.5 inch.....	15-2KA-40	
1	Handy roller, 0.375 inch.....	15-2KA-40	
8	Axle sprocket bolts.....	15-2KA-40	AB40M.
1	Axle sprocket.....	15-2KA-40	AB40N.
1	Axlesprocket retainer.....	15-2KA-38	AB38A.
4	Axlesprocket retainer bolt.....	15-2KA-38	AB38B.
2	Do.....	15-2KA-38	AB38C.
6	Crown nuts.....	15-2KA-38	
12	Separator steel.....	15-2KA-38	AB38E.
1	Do.....	15-2KA-38	AB38F.
2	Do.....	15-2KA-38	AB38G.
1	Lock pin.....	15-2KA-38	AB38D.
1	Sleeve.....	15-2KA-39	AB39A.
1	Driving ring.....	15-2KA-39	AB39B.
4	Driving pins.....	15-2KA-39	AB39C.
1	Frame brace (right).....	15-2KA-39	AB39D.
1	Frame brace (left).....	15-2KA-39	AB39E.
4	Crown nuts, 0.5 inch.....	15-2KA-39	
8	Carriage bolts.....	15-2KA-39	AB39F.
8	Nuts.....	15-2KA-39	A39G.
2	Steel dowel pins.....	15-2KA-39	
1	Gear case, inner.....	15-2KE-64	EB64F.
1	Gear case, outer.....	15-2KE-64	EB64B.
1	Gear case separator.....	15-2KE-64	EB64A.
1	Gear case strap (front).....	15-2KE-64	EB64K.
1	Gear case strap (rear).....	15-2KE-64	EB64P.
1	Gear case support (front).....	15-2KE-64	EB64N.
1	Key.....	15-2KA-40	AB40P.
1	Nut, 0.5 inch.....	15-2KA-40	
1	<b>Drum latch, complete, consisting of—</b>		
1	Drum latch bearing.....	15-2KJ-16	JB16R.
1	Drum latch bearing bolt.....	15-2KJ-16	JB16M.
1	Do.....	15-2KJ-16	JB16U.
1	Drum latch bearing bolt washer.....	15-2KJ-16	JB16Q.
1	Drum latch bearing cap.....	15-2KJ-16	JB16P.
1	Drum latch block.....	15-2KJ-16	JB16G.
1	Drum latch bracket.....	15-2KJ-16	JB16N.
1	Drum latch brake shoe.....	15-2KJ-16	JB16L.
1	Drum latch brake shoe pin.....	15-2KJ-16	JB16D.
1	Drum latch handle.....	15-2KJ-16	JB16W.
2	Drum latch handle pins.....	15-2KJ-16	JB16E.
1	Drum latch lever.....	15-2KJ-16	JB16C.
1	Drum latch pawl.....	16-2KJ-16	JB16T.
1	Drum latch pawl rod.....	15-2KJ-16	JB16S.
1	Drum latch pawl spring.....	15-2KJ-16	JB16B.
1	Drum latch plunger.....	15-2KJ-16	JB16F.
1	Drum latch plunger spring.....	15-2KJ-16	JB16A.
1	Drum latch segment.....	15-2KJ-16	JB16H.
1	<b>Frame, complete, consisting of—</b>		
1	Rear cross rail (outer).....	13-27-6	6A.
1	Rear cross rail (inner).....	13-27-7	7A.
1	Cross rail gusset (left).....	13-27-8	8A.
1	Foot rest.....	13-27-8	8B.
18	Separator (for 0.5 rivet) 1.967 (1 $\frac{1}{4}$ ) inches long.....	13-27-8	8C.
2	Rear cross rail covers.....	13-27-8	8D.
1	Cross brace, front.....	15-2KA-34	AB34G.
1	Cross brace, rear.....	15-2KA-34	AB34H.
1	Cross brace nut.....	15-2KA-34	AB34E.
1	Name plate.....	13-27-16	16A.
1	Rail reinforce (right).....	13-27-24	24F.
1	Rail reinforce (left).....	15-2KE-68	EB63C.
8	Steelscrews.....	13-27-8	8E.
1	Side rail front (right).....	15-2KE-67	EB68C.
1	Side rail front (left).....	15-2KE-67	EB67A.
1	<b>Lantern bracket, complete, consisting of—</b>		
2	Lantern bracket bottom.....	15-2KH-47	HB47B.
1	Lantern bracket front.....	15-2KH-47	HB47C.
2	Lantern strap fastener.....	15-2KH-1	HB1C.
1	Lantern bracket back.....	15-2KH-47	HB47A.

Number.	Name of part.	Drawing.	Piece mark.
1	Leg guard, complete, consisting of—		
1	Bottom piece.....	13-27-14.....	14C.
1	Gusset.....	13-27-14.....	14B.
1	Side piece.....	13-27-14.....	14A.
1	Pole prop, complete, consisting of—		
1	Pole prop bracket No. 1.....	15-2KE-62.....	EB62F.
1	Pole support spring.....	15-2KA-13.....	AB13C.
1	Pole prop bracket No. 2.....	15-2KE-62.....	EB62G.
2	Prop bracket half.....	15-2KL-2.....	LB2C.
1	Prop chain.....	15-2KL-1.....	LB1R.
1	Prop chain button.....	15-2KL-1.....	LB1BA.
1	Prop chain eye.....	15-2KL-2.....	LB2F.
1	Prop chain fastening.....	15-2KL-1.....	LB1N.
1	Prop chain handle.....	15-2KL-1.....	LB1P.
1	Prop eye.....	15-2KL-1.....	LB1B.
1	Prop foot.....	15-2KL-1.....	LB1A.
1	Prop tube.....	15-2KL-1.....	LB1E.
1	Roller, front, consisting of—		
1	Roller.....	13-27-13.....	13B.
2	Roller bearings.....	13-27-16.....	16B.
1	Roller bracket (right).....	13-27-12.....	12B.
1	Roller bracket (left).....	13-27-12.....	12C.
2	Split pins.....	13-27-12.....	
2	Handy oilers.....	13-27-12.....	
6	Rivets, 0.25 inch.....	13-27-12.....	
2	Roller studs.....	13-27-12.....	12E.
2	Front roller end plates.....	15-2KA-41.....	AB41A.
4	Wood screws.....		
1	Collar.....	15-2KA-41.....	AB41C.
1	Roller, rear, consisting of—		
1	Rear roller.....	13-27-13.....	13E.
1	Rear roller bracket (right).....	13-27-13.....	13C.
1	Rear roller bracket (left).....	13-27-13.....	13A.
2	Split pins, 0.125 by 1.25 inches.....	13-27-13.....	
1	Bolt, bracket (right).....	13-27-13.....	13D.
1	Nut, bracket (right).....	13-27-13.....	
1	Washer, bracket (right).....	13-27-13.....	
10	Rivets, 0.375 inch.....	13-27-13.....	
2	Roller bearings.....	13-27-16.....	16B.
2	Roller studs.....	15-2KA-41.....	AB41D.
2	Handy oilers.....	15-2KA-41.....	
2	Rear roller end plate.....	15-2KA-41.....	AB41E.
4	Wood screws.....		
1	Seat, complete, consisting of—		
1	Seat.....	15-2KF-65.....	EB65A.
1	Seat brace.....	15-2KE-65.....	EB65C.
1	Seat rail.....	15-2KM-8.....	MB8A.
1	Seat rail foot (right).....	15-2KM-8.....	MB8C.
1	Seat rail foot (left).....	15-2KM-8.....	MB8B.
3	Seat rail supports.....	15-2KM-8.....	MB8B.
1	Seat reinforce.....	15-2KE-65.....	EB65D.
1	Seat spring.....	13-27-12.....	12A.
1	Tool box, complete, consisting of—		
1	Bottom board.....	13-27-23.....	23A.
1	Tray block No. 1.....	13-27-23.....	23B.
1	Tray block No. 2.....	13-27-23.....	23C.
3	Steel wood screws, 10 by 1.25 inches.....	13-27-23.....	23D.
1	Tray body.....	13-27-23.....	23F.
2	Steel wood screws, 10 by 0.875 inch.....	13-27-23.....	23F.
1	Oil retainer.....	13-27-23.....	23G.
1	Oil retainer spring.....	13-27-23.....	23H.
1	Tool box support.....	13-27-23.....	23K.
4	Brass belt rivets, No. 8.....	13-27-23.....	
1	Tool box.....	13-27-24.....	24A.
2	Tool box hinges.....	15-2KG-1.....	GB1Z.
1	Tool box partition.....	13-27-24.....	24G.
1	Tool box lid.....	13-27-24.....	24B.
1	Padlock, clevis, and clevis rivet.....	15-2KJ-5.....	JB5F.
2	Chain rings.....	15-2KJ-5.....	JB5M.
1	Chain rivet.....	15-2KJ-5.....	JB5L.
1	Chain for padlock.....	15-2KJ-5.....	JB5N.
1	Staple (tool box).....	15-2KG-5.....	GB5K.
1	Wheels, 56-inch, complete, consisting of—		
16	Tire bolts with nuts.....	15-2KP-9.....	PB9B.
8	Felloe segments.....	15-2KP-52.....	PB52C.
8	Dowels.....	15-2KP-16.....	PB16G.
16	Spokes (right).....	15-2KP-52.....	PB52A.
16	Spokes (left).....	15-2KP-52.....	PB52B.
22	Spoke shoes.....	15-2KP-9.....	PB9Q.
22	Spoke shoe plates.....	15-2KP-9.....	PB9S.
22	Spoke shoe rivets.....	15-2KP-9.....	PB9L.
2	Tires.....	15-2KP-9.....	PB9A.
2	Hub boxes.....	15-2KP-10.....	PB10A.
2	Hub liners.....	15-2KP-10.....	PB10B.
2	Hub rings.....	15-2KP-10.....	PB10D.

Number.	Name of part.	Drawing.	Piece mark.
Wheels, 50-inch complete, consisting of—Continued.			
16	Carrage bolts with nuts.....	15-2KP-9	PB9K.
2	Hub bands.....	15-2KP-10	PB10G.
2	Hub washers (lock).....	15-2KP-10	PB10F.
2	Hub caps.....	15-2KP-10	PB10L.
2	Hub latches with rivets.....	15-2KP-16	PB16A.
2	Hub latch springs.....	15-2KP-16	PB16B.
2	Hub latch plungers.....	15-2KP-16	PB16C.
2	Oil valves.....	15-2KP-5	PB5B.
2	Washers (oil valve).....	15-2KP-5	PB5C.
2	Springs (oil valve).....	15-2KP-5	PB5A.
2	Oil valve rivets (bronze).....	15-2KP-5	PB5E.
16	Washers (tire bolt).....	15-2KP-9	PB9C.
Wheel fastenings, complete, consisting of—			
2	Wheel fastenings.....	15-2KP-10	PB10K.
2	Wheel fastening plungers.....	15-2KP-16	PB16D.
2	Wheel fastening springs.....	15-2KP-16	PB16E.
2	Wheel fastening plugs.....	15-2KP-16	PB16F.
2	Rivets.....	15-2KP-16	
Set rivets, complete—			
1	Rivet, brass, belt, 0.125-inch diameter.....	15-2KJ-16	
2	Rivet, brass, belt, No. 8.....	13-27-23	
4	Rivets, bronze, countersunk, 0.125 by $\frac{1}{2}$ inch.....	15-2KA-42	
39	Rivets, steel, button head, $\frac{1}{4}$ by $\frac{1}{2}$ inch.....		
6	Rivets, steel, button head, $\frac{1}{4}$ by $\frac{1}{2}$ inch.....		
4	Rivets, steel, button head, $\frac{1}{4}$ by $\frac{1}{2}$ inch.....		
5	Rivets, steel, button head, $\frac{1}{4}$ by $\frac{1}{2}$ inch.....		
4	Rivets, steel, button head, $\frac{1}{4}$ by $\frac{1}{2}$ inches.....		
9	Rivets, steel, button head, $\frac{1}{4}$ by $\frac{1}{2}$ inches.....		
3	Rivets, steel, button head, $\frac{1}{4}$ by 2 inches.....		
1	Rivets, steel, button head, $\frac{1}{4}$ by 2 inches.....	15-2KL-3	
22	Rivets, steel, button head, $\frac{1}{4}$ by $\frac{1}{2}$ inch.....		
41	Rivets, steel, button head, $\frac{1}{4}$ by $\frac{1}{2}$ inch.....		
23	Rivets, steel, button head, $\frac{1}{4}$ by $\frac{1}{2}$ inch.....		
1	Rivets, steel, button head, $\frac{1}{4}$ by $\frac{1}{2}$ inch.....		
8	Rivets, steel, button head, $\frac{1}{4}$ by $\frac{1}{2}$ inch.....		
2	Rivets, steel, button head, $\frac{1}{4}$ by $\frac{1}{2}$ inches.....		
42	Rivets, steel, button head, $\frac{1}{4}$ by $\frac{1}{2}$ inch.....		
24	Rivets, steel, button head, $\frac{1}{4}$ by $\frac{1}{2}$ inch.....		
9	Rivets, steel, button head, $\frac{1}{4}$ by $\frac{1}{2}$ inch.....		
6	Rivets, steel, button head, $\frac{1}{4}$ by $\frac{1}{2}$ inch.....		
1	Rivets, steel, button head, $\frac{1}{4}$ by $\frac{1}{2}$ inches.....		
3	Rivets, steel, button head, $\frac{1}{4}$ by $\frac{1}{2}$ inches.....		
6	Rivets, steel, button head, $\frac{1}{4}$ by $\frac{1}{2}$ inches.....		
1	Rivets, steel, button head, $\frac{1}{4}$ by $\frac{1}{2}$ inches.....		
3	Rivets, steel, button head, $\frac{1}{4}$ by $\frac{1}{2}$ inch.....	15-2KL-3	
1	Rivets, steel, button head, $\frac{1}{4}$ by $\frac{1}{2}$ inch.....		
26	Rivets, steel, button head, $\frac{1}{4}$ by $\frac{1}{2}$ inch.....		
62	Rivets, steel, button head, $\frac{1}{4}$ by $\frac{1}{2}$ inches.....		
26	Rivets, steel, button head, $\frac{1}{4}$ by $\frac{1}{2}$ inches.....		
24	Rivets, steel, button head, $\frac{1}{4}$ by $\frac{1}{2}$ inches.....		
28	Rivets, steel, button head, $\frac{1}{4}$ by $\frac{1}{2}$ inches.....		
31	Rivets, steel, button head, $\frac{1}{4}$ by $\frac{1}{2}$ inches.....		
6	Rivets, steel, button head, $\frac{1}{4}$ by $\frac{1}{2}$ inch.....		
10	Rivets, steel, button head, $\frac{1}{4}$ by $\frac{1}{2}$ inches.....		
3	Rivets, steel, button head, $\frac{1}{4}$ by $\frac{1}{2}$ inches.....		
1	Rivets, steel, button head, $\frac{1}{4}$ by $\frac{1}{2}$ inches.....		
1	Rivets, steel, button head, $\frac{1}{4}$ by $\frac{1}{2}$ inches.....		
1	Rivets, steel, button head, $\frac{1}{4}$ by $\frac{1}{2}$ inches.....		
1	Rivets, steel, button head, $\frac{1}{4}$ by $\frac{1}{2}$ inches.....		
2	Rivets, steel, button head, $\frac{1}{4}$ by $\frac{1}{2}$ inches.....		
2	Rivets, steel, button head, $\frac{1}{4}$ by 2 inches.....		
2	Rivets, steel, button head, $\frac{1}{4}$ by 2 inches.....		
2	Rivets, steel, button head, $\frac{1}{4}$ by 2 inches.....		
12	Rivets, steel, button head, $\frac{1}{4}$ by 3 inches.....		
2	Rivets, steel, button head, $\frac{1}{4}$ by 3 inches.....		
2	Rivets, steel, button head, $\frac{1}{4}$ by 3 inches.....		
10	Rivets, steel, countersunk, $\frac{1}{4}$ by $\frac{1}{2}$ inches.....		
8	Rivets, steel, countersunk, $\frac{1}{4}$ by $\frac{1}{2}$ inch.....		
2	Rivets, steel, countersunk, $\frac{1}{4}$ by $\frac{1}{2}$ inch.....		
4	Rivets, steel, countersunk, $\frac{1}{4}$ by $\frac{1}{2}$ inches.....		
4	Rivets, steel, countersunk, $\frac{1}{4}$ by $\frac{1}{2}$ inches.....		
8	Rivets, steel, countersunk, $\frac{1}{4}$ by $\frac{1}{2}$ inches.....		
6	Rivets, steel, countersunk, $\frac{1}{4}$ by $\frac{1}{2}$ inches.....		
2	Rivets, steel, countersunk, $\frac{1}{4}$ by $\frac{1}{2}$ inch.....		
6	Rivets, steel, countersunk, $\frac{1}{4}$ by $\frac{1}{2}$ inches.....		
8	Rivets, steel, countersunk, $\frac{1}{4}$ by $\frac{1}{2}$ inches.....		
2	Rivets, steel, countersunk, $\frac{1}{4}$ by $\frac{1}{2}$ inches.....		
3	Rivets, steel, countersunk, $\frac{1}{4}$ by $\frac{1}{2}$ inches.....		
10	Rivets, steel, countersunk, $\frac{1}{4}$ by $\frac{1}{2}$ inches.....		
2	Rivets, steel, countersunk, $\frac{1}{4}$ by $\frac{1}{2}$ inches.....		
1	Rivets, steel, countersunk, $\frac{1}{4}$ by 3 inches.....	15-2KL-3	
.....	Rivets, wrought iron, A-2.44.....	15-2KL-5	LB5A.
.....	Rivets, wrought iron, A-2.19.....	15-2KL-5	LB5B.

## DESCRIPTION OF THE REEL.

The Reel, model of 1909 MI, Plate XXXV, is a two-wheeled vehicle designed to carry, lay, and recover 8 miles of insulated cable. It has interchangeable pole connections which enables it to be adapted to either horse or motor traction.

The principal units are the wheel, axis, frame, drums, drum-driving gear, clutches, drum brakes, connecting pole, operator's seat pintle and automatic pole support. In order to lay the wire, which is carried on the two drums, the latter are disengaged from the clutch and are permitted to revolve free upon their axis, subject to control by the braking action of the drum latch and drum brake, or the friction clutch when applied for that purpose. To recover the wire or wind it upon the drums, the clutch in the right drum is applied and the drum made to revolve through the chain driving gear connected to the right wheel. The left drum is driven by the right drum through a pin clutch, which is operated by a handle in the left outer end of the left drum.

The frame, complete, is an assemblage of special shaped pressed steel members together with gusset plates, reinforce pieces, the pole socket at the front, automatic pole support, and pintle at the rear and the assembled axle. The latter includes three parallel tubes horizontally fixed between two axle brackets, from the outer faces of which project the axle arms. The side rails, riveted to seats on the inner side of the axle brackets, extend to the front and converge to the pole socket, to which they are secured. The front cross rail extends laterally between the side rails, and at its mid-point is attached the rear end of the pole socket. A tool box with a lid opening on the top is assembled in the space on the right side of the pole socket between the side rail and the front cross rail. The inside bore of the pole socket conforms to the taper on both the connecting pole and the (horse) pole. Holes are provided in the socket for assembling the rectangular key and the pole pine which are used to secure in place the connecting pole and (horse) pole, respectively. The rear portion of the frame consists of two U-shaped members riveted together to form a hollow flask of square section. This assembled piece is rigidly secured to the axle brackets; it is reinforced by gusset plates on the corners, and at its rear mid-point is located the automatic pole support and pintle. An operator's seat and a leg guard are mounted on the right corner of the rear cross rail.

A wooden roller to protect the wire when it is being laid or recovered is suspended from brackets beneath the rear cross rail, and a similar but smaller roller is supported in brackets (attached to the rear cross rail) immediately in front and above the rear roller. Two connecting pole brackets for carrying the connecting pole when

not in use are riveted to the frame, one at the front and one at the rear, on the left side.

The top member of the three parallel tubes connecting the axle brackets serves also as an axle for the drums. The left end is closed with a stopper; the right is finished to receive within it parts of the clutch. Four paths for roller bearings, which fit in the drumheads and upon which the drums rotate, are finished upon the drum axle. The two drums each consist of a cylindrical body of perforated flange steel in the ends of which are riveted drumheads. To each of the latter is riveted a circular corrugated end plate which extends perpendicularly from the axis of the axle and the body of the drum. On the right end of the drum axle between the right axle bracket and the right end of the right drum is assembled an annular disk, the sprocket ring, which rotates upon the drum axle. A sprocket secured to this ring is driven by a roller chain from a sprocket on a jack shaft which in turn is driven by a second roller chain carried on sprockets on the jack shaft and a hub on the right axle arm. This hub and the axle sprocket are driven by a bronze driving ring bolted to the hub box of the right wheel. Four steel pins fitted in the driving ring assemble in corresponding holes in the axle sprocket and thus drive it. Owing to the angularity of axes of wheel and axle sprocket, the driving pins work in and out of the sprocket holes as the wheel revolves.

The clutch connecting the drum driving gear and the right drum is located in a recess in the right drumhead behind the revolving annular disk—the sprocket ring. This disk is assembled between an adjusting ring, threaded into the end of the recessed drumhead and a second friction disk arranged with a slight axial movement along the drum axle. Movement of the friction disk against the sprocket ring clamps the sprocket ring between the friction disk and the adjusting ring and thus connects the driving mechanism to the drum. Three toggle links pivoted to the friction disk, the right drumhead and a sliding collar or clutch spider applies or releases the clutch according to the action of the spider. The latter is moved along the drum axle by a sleeve sliding in the interior of the drum axle and connected to the clutch spider by two keys working through slots in the axle wall. The sleeve is threaded on its outer end and is actuated by a nut formed in the hub of a bevel gear meshing with a pinion on the lower end of a handwheel shaft mounted on the right axle bracket.

The pin clutch that connects the left drum is operated by a handle in the left drumhead of the left drum. The handle is secured to a rod which passes through the interior of the drum and through a hole in the right drumhead of the left drum. A socket in the

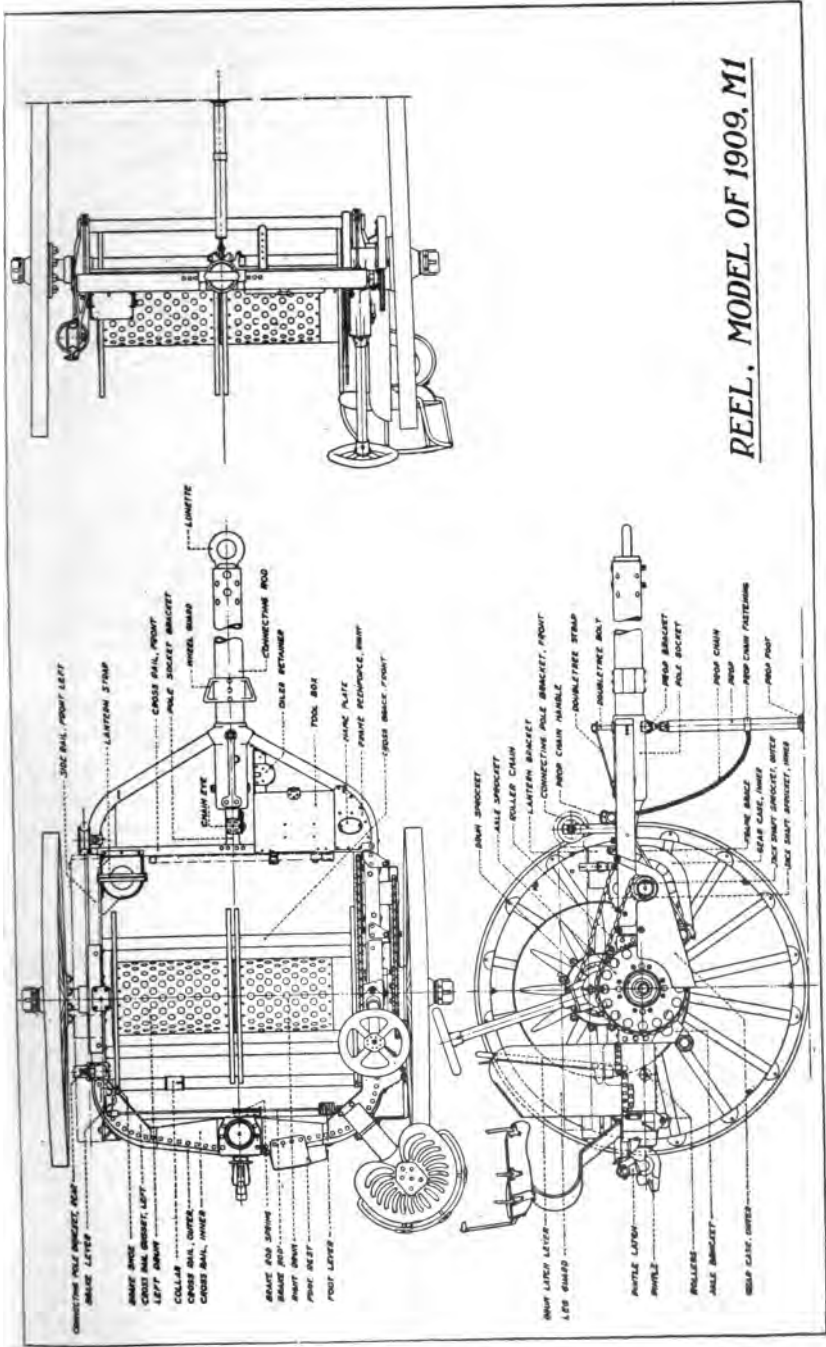

REEL, MODEL OF 1909, M1

PLATE XLV

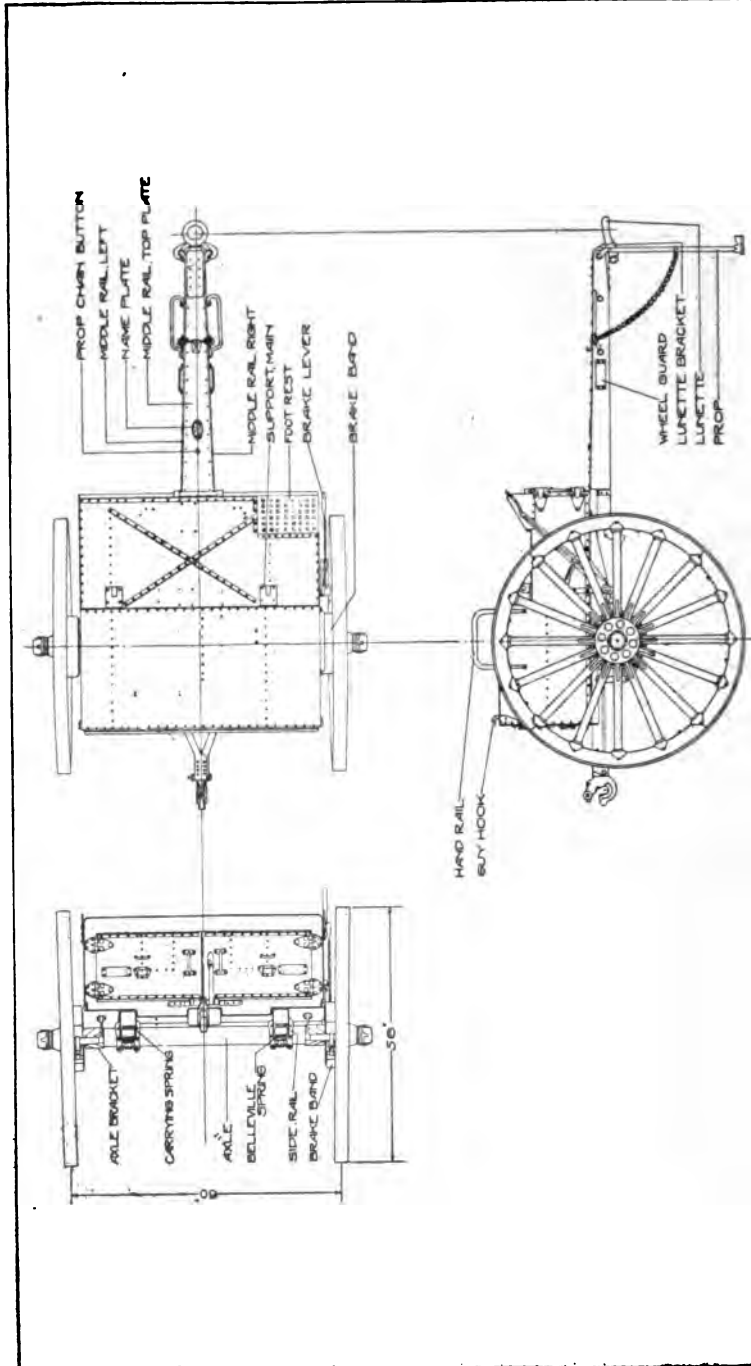

CART-MODEL OF 1918

Number.	Name of part.	Drawing.	Piece mark.
	Chest, complete, consisting of—Continued.		
4	Shield hinge, male (rear door).....	15-2KG-2	GB2A.
4	Shield hinge, female (rear door).....	15-2KG-2	GB2B.
4	Hinge pin (rear door).....	15-2KG-2	GB2R.
6	Carriage bolts, 3/16 by 8 inches.....	13-28-35	35B.
6	Shelf.....	13-28-35	35C.
1	Nuts, square, 3/16 inch.....	13-28-12	26C.
2	Lid hinge, male.....	13-28-12	12H.
2	Lid hinge, female.....	13-28-12	12G.
1	Pick handle bracket, head end.....	13-28-25	25D.
1	Pick handle bracket, handle end.....	13-28-25	25E.
1	Pick head bracket, right.....	13-28-25	25B.
1	Pick head bracket, left.....	13-28-25	25C.
1	Sledge head bracket.....	13-28-25	25A.
2	Spring.....	13-24-14	14E.
3	Split pins, 5/32 by 1½ inches.....		
1	Chest cover plate.....	13-28-11	11F.
4	Cover, plate angle.....	13-28-11	
	1-1 by 1 by 0.125 by 17.125 inches long.....	13-28-11	11L.
	1-1 by 1 by 0.125 by 20.75 inches long.....	13-28-11	11K.
	1-1 by 1 by 0.125 by 38.75 inches long.....	13-28-11	11H.
	1-1 by 1.5 by 0.125 by 52.875 inches long.....	13-28-11	11G.
1	Partition.....	13-28-8	8B.
1	Do.....	13-28-35	35A.
1	Do.....	13-28-35	35D.
1	Lock bar A (front door).....	13-28-16	16C.
1	Lock bar B (rear door).....	13-28-16	16D.
2	Lock bar bearing (front).....	13-28-16	16B.
2	Lock bar bearing (rear).....	13-28-16	16A.
1	Barrel bolt (commercial)—		
	1 bolt.....	13-38-14	14G.
	1 bolt case.....	13-28-14	14F.
	1 knob.....	13-28-14	14H.
	Bucket holder.....	15-2KH-46	HB46C.
1	Buckle, roller, 1.25.....	20-0-1	
2	Corner angle.....	13-28-36	36B.
4	Do.....	13-28-36	36C.
4	Do.....	13-28-36	36D.
2	Do.....	13-28-36	36E.
2	Do.....	13-28-14	14K.
1	Filler.....	15-2KH-44	HB44A.
2	Fastening base.....	15-2KH-17	HB17D.
2	Fastening lever.....	15-2KL-16	LB16B.
1	Fastening pin.....	15-2KH-44	HB44C.
2	Fastening spring.....	13-28-15	15A.
2	Guy hook.....	13-28-36	36L.
4	Wood screws, 1.75-inch, flat head.....	13-28-36	36M.
18	Wood screws, 0.75-inch, round head.....	15-2KH-17	HB17M.
2	Fastening lever pins, 0.201 by 2 inches.....	15-2KH-17	HB17P.
2	Pins, 0.201 by 2.625 inches.....	15-2KH-17	HB17H.
1	Sledge handle fastening.....	15-2KH-43	HB43A.
2	Spring catch.....	15-5-219	
1	Ax strap, 17.5 inches.....	15-5-219	
1	Bucket strap, 24 inches.....	15-5-219	
1	Megaphone strap, 24 inches.....	15-5-219	
2	Paulin straps, 42 inches.....	15-5-219	
1	Pick handle strap, 11.5 inches.....	15-5-219	
1	Pick head strap, 18 inches.....	15-5-219	
3	Picket rope straps, 20 inches.....	15-5-219	
3	Picket rope straps, 8 inches.....	15-5-219	
1	Shovel blade strap, 24 inches.....	15-5-219	
2	Loose keepers.....	15-5-219	
1	Strap shoe.....	15-5-219	
1	Hatchet blade bracket (left).....	15-2KH-2	HB2Q.
1	Hatchet blade bracket (right).....	15-2KH-2	HB2F.
1	Hatchet handle rest (right).....	15-2KH-2	HB2L.
1	Hatchet handle rest (left).....	15-2KH-2	HB2R.
1	Hinge (male).....	13-28-14	14A.
1	Hinge (female).....	13-28-14	14C.
1	Hinge pin.....	13-28-14	14B.
2	Do.....	13-28-12	12K.
1	Spring filler (hatchet), right.....	15-2KH-44	HB44H.
1	Spring filler (hatchet), left.....	15-2KH-44	HB44K.
2	Support, main.....	13-28-15	15C.
	Road brake, complete, consisting of—		
2	Split pins, ¼ by 1½ inches.....	15-2KB-8	
8	Lock washers, carriage bolts.....	30-2-6	Q6PC.
6	Crown nuts, 0.375-inch.....	30-2-6	Q6SA.
1	Split pin, ¼ by 1½ inches.....		
2	Brake band body.....	15-2KB-8	BB8M.
2	Brake shaft.....	15-2KB-16	BB16H.
4	Brake band end.....	15-2KB-8	BB8L.
2	Brake band lining.....	15-2KB-8	BB8C.
4	Band clip.....	15-2KB-9	BB9N.
4	Band guide.....	15-2KB-9	BB9F.
2	Brake drum.....	15-2KB-8	BB8A.
1	Brake hanger (right).....	15-2KB-16	BB16K.

## NOMENCLATURE OF THE CART.

(Property Classification, Class IV, Division 3.)

The battery personnel is directed to use the following nomenclature giving piece marks and drawing numbers, when referring to parts of the carts in reports, correspondence, etc.

Number.	Name of part.	Drawing.	Piece mark.
	Chest, complete, consisting of—		
1	Chest body.....	13-28-4.....	4B.
1	Chest front.....	13-28-4.....	4A.
1	Bottom plate, right.....	13-28-5.....	5F.
1	Bottom plate, left.....	13-28-5.....	5A.
1	Bottom plate, center.....	13-28-5.....	5B.
1	Chest rear frame.....	13-28-6.....	6A.
1	Rear frame stiffener.....	13-28-6.....	6B.
1	Rear frame angle.....	13-28-6.....	6C.
1	Rear door, right.....	13-28-12.....	12D.
1	Rear door, left.....	13-28-12.....	12A.
1	Door stiffener, lower, right.....	13-28-12.....	12F.
1	Door stiffener, lower, left.....	13-28-12.....	12C.
1	Door stiffener, upper, right.....	13-28-12.....	12E.
1	Door stiffener, upper, left.....	13-28-12.....	12B.
4	Door handle bar.....	15-2KM-2.....	MB2Q.
8	Door handle base.....	15-2KM-2.....	MB2P.
1	Front door, right.....	13-28-11.....	11A.
1	Front door, left.....	13-28-11.....	11B.
1	Door stiffener, 19 inches long.....	13-28-11.....	11E.
1	Door stiffener, 21 inches long.....	13-28-11.....	11D.
2	Door stiffener, 25 inches long.....	13-28-11.....	11C.
2	End reinforce.....	15-2KA-18.....	A B18F.
4	Door hinge, female (front door).....	15-2K-45.....	C45C.
4	Door hinge, male (front door).....	15-2K-45.....	C45D.
4	Hinge pin (front door).....	15-2KG-2.....	GB2Q.
1	Transom, right.....	13-28-7.....	7A.
1	Transom, left.....	13-28-7.....	7B.
1	Center transom, right.....	13-28-7.....	7D.
1	Center transom, left.....	13-28-7.....	7C.
1	Transom, reinforce, right.....	13-28-8.....	8D.
1	Transom, reinforce, left.....	13-28-8.....	8C.
1	Upper transom.....	13-28-8.....	8A.
2	Wing nuts.....	15-2KJ-1.....	1B1Q.
1	Intermediate plate, right.....	13-28-9.....	9A.
1	Intermediate plate, left.....	13-28-9.....	9B.
1	Intermediate plate, front.....	13-28-10.....	10A.
1	Intermediate plate, center.....	13-28-9.....	9C.
1	Intermediate plate, stiffener.....	13-28-14.....	14D.
4	Filler plate.....	13-28-16.....	16E.
1	Strap fastener.....	13-28-11.....	11M.
5	Loops, No. 1.....	15-2KN-1.....	NB1T.
3	Strap fasteners, No. 1.....	15-2KN-1.....	NB1A.
2	Strap fasteners, No. 2.....	15-2KN-1.....	NB1B.
17	Strap fasteners, No. 15.....	15-2KN-1.....	NB1R.
1	Ax handle support.....	15-2K-47.....	C47F.
1	Ax head bracket.....	15-2K-47.....	C47K.
2	Wing nut pins.....	15-2K-93.....	C93G.
3	Wing nut pin washers.....	15-2KJ-1.....	JB1R.
2	Crown nuts, 0.75 inch.....	30-2-6.....	Q6GA.
2	Bolt snap.....	15-2KJ-5.....	JB5J.
2	Padlock.....	15-2KJ-5.....	JB5F.
2	Padlock chain.....	15-2KJ-5.....	JB5C.
2	Chain rivet.....	15-2KJ-5.....	JB5L.
4	Chain ring.....	15-2KJ-5.....	JB5M.
1	Chest bracket, right.....	13-28-5.....	5D.
1	Chest bracket, left.....	13-28-5.....	5E.
1	Chest brace, "A" right.....	13-28-10.....	10B.
1	Chest brace, "A" left.....	13-28-10.....	10C.
1	Chest brace, "B" right.....	13-28-10.....	10D.
1	Chest brace, "B" left.....	13-28-10.....	10E.
2	Chest stiffener.....	13-28-4.....	4C.
2	Plotting board slide support.....	13-28-36.....	36F.
2	Plotting board slide (wood).....	13-28-36.....	36G.
1	Door box lid, right.....	13-28-12.....	12L.
1	Door box lid, left.....	13-28-12.....	12M.
1	Door box body, right.....	13-28-13.....	13D.
1	Door box body, left.....	13-28-13.....	13E.
2	Door box end, left.....	13-28-13.....	13A.
1	Megaphone rubbing piece.....	13-28-16.....	16F.
2	Handrail shank.....	15-2KM-2.....	MB2B.
1	Handrail.....	15-2KM-2.....	MB2G.
1	Foot rest.....	13-28-10.....	10F.
1	Door box end, right (right door).....	13-28-13.....	13B.
1	Door box end, right (left door).....	13-28-13.....	13C.

Number.	Name of part.	Drawing.	Piece mark.
	Chest, complete, consisting of—Continued.		
4	Shield hinge, male (rear door).....	15-2KG-2	GB2A.
4	Shield hinge, female (rear door).....	15-2KG-2	GB2B.
4	Hinge pin (rear door).....	15-2KG-2	GB2R.
6	Carriage bolts, 3/16 by 8 inches.....	13-28-35	35B.
1	Shelf.....	13-28-35	35C.
6	Nuts, square, 3/16 inch.....	13-28-26	26G.
2	Lid hinge, male.....	13-28-12	12H.
2	Lid hinge, female.....	13-28-12	12G.
1	Pick handle bracket, head end.....	13-28-25	25D.
1	Pick handle bracket, handle end.....	13-28-25	25E.
1	Pick head bracket, right.....	13-28-25	25B.
1	Pick head bracket, left.....	13-28-25	25C.
1	Sledge head bracket.....	13-28-25	25A.
2	Spring.....	13-24-14	14E.
3	Split pins, 5/32 by 1 1/4 inches.....		
1	Chest cover plate.....	13-28-11	11F.
4	Cover, plate angle.....	13-28-11	
	1-1 by 1 by 0.125 by 17.125 inches long.....	13-28-11	11L.
	1-1 by 1 by 0.125 by 20.75 inches long.....	13-28-11	11K.
	1-1 by 1 by 0.125 by 38.75 inches long.....	13-28-11	11H.
	1-1 by 1.5 by 0.125 by 52.875 inches long.....	13-28-11	11G.
1	Partition.....	13-28-8	8B.
1	Do.....	13-28-35	35A.
1	Do.....	13-28-35	35D.
1	Lock bar A (front door).....	13-28-16	16C.
1	Lock bar B (rear door).....	13-28-16	16D.
2	Lock bar bearing (front).....	13-28-16	16B.
2	Lock bar bearing (rear).....	13-28-16	16A.
1	Barrel bolt (commercial)—		
	1 bolt.....	13-38-14	14G.
	1 bolt case.....	13-28-14	14F.
	1 knob.....	13-28-14	14H.
1	Bucket holder.....	15-2KH-46	HB46C.
2	Buckle, roller, 1.25.....	20-0-1	
4	Corner angle.....	13-28-36	36B.
2	Do.....	13-28-36	36C.
2	Do.....	13-28-36	36D.
1	Do.....	13-28-36	36E.
2	Filler.....	13-28-14	14K.
2	Fastening base.....	15-2KH-44	HB44A.
1	Fastening lever.....	15-2KH-17	HB17D.
1	Fastening pin.....	15-2KL-16	LB16B.
2	Fastening spring.....	15-2KH-44	HB44C.
4	Guy hook.....	13-28-15	15A.
18	Wood screws, 1.75-inch, flat head.....	13-28-36	36L.
2	Wood screws, 0.75-inch, round head.....	13-28-36	36M.
2	Fastening lever pins, 0.201 by 2 inches.....	15-2KH-17	HB17M.
2	Pins, 0.201 by 2.625 inches.....	15-2KH-17	HB17P.
1	Sledge handle fastening.....	15-2KH-17	HB17H.
2	Spring catch.....	15-2KH-43	HB43A.
1	Ax strap, 17.5 inches.....	15-5-219	
1	Bucket strap, 24 inches.....	15-5-219	
1	Megaphone strap, 24 inches.....	15-5-219	
2	Paulin straps, 42 inches.....	15-5-219	
1	Pick handle strap, 11.5 inches.....	15-5-219	
1	Pick head strap, 18 inches.....	15-5-219	
3	Picket rope straps, 20 inches.....	15-5-219	
3	Picket rope straps, 8 inches.....	15-5-219	
1	Shovel blade strap, 24 inches.....	15-5-219	
2	Loose keepers.....	15-5-219	
1	Strap shoe.....	15-5-219	
1	Hatchet blade bracket (left).....	15-2KH-2	HB2Q.
1	Hatchet blade bracket (right).....	15-2KH-2	HB2F.
1	Hatchet handle rest (right).....	15-2KH-2	HB2L.
1	Hatchet handle rest (left).....	15-2KH-2	HB2R.
1	Hinge (male).....	13-28-14	14A.
1	Hinge (female).....	13-28-14	14C.
1	Hinge pin.....	13-28-14	14B.
2	Do.....	13-28-12	12K.
1	Spring filler (hatchet), right.....	15-2KH-44	HB44H.
1	Spring filler (hatchet), left.....	15-2KH-44	HB44K.
2	Support, main.....	13-28-15	15C.
1	Road brake, complete, consisting of—		
2	Split pins, 1/4 by 1 1/4 inches.....	15-2KB-8	
8	Lock washers, carriage bolts.....	30-2-6	Q6PC.
6	Crown nuts, 0.375-inch.....	30-2-6	Q6SA.
1	Split pin, 1/4 by 1 1/4 inches.....		
2	Brake band body.....	15-2KB-8	BB8M.
2	Brake shaft.....	15-2KB-16	BB16H.
4	Brake band end.....	15-2KB-8	BB8L.
2	Brake band lining.....	15-2KB-8	BB8C.
4	Band clip.....	15-2KB-9	BB9N.
4	Band guide.....	15-2KB-9	BB9F.
2	Brake drum.....	15-2KB-8	BB8A.
1	Brake hanger (right).....	15-2KB-16	BB16K.

Number.	Name of part.	Drawing.	Piece mark.
	<b>Road brake, complete, consisting of—Continued.</b>		
1	Brake hanger (left).....	15-2KB-16.	BR16L.
1	Brake lever hook.....	15-2B-23.	21P.
1	Brake crank.....	15-2KB-24.	BB24B.
2	Brake crank shaft bearing.....	13-27-23.	23F.
1	Brake crank shaft.....	15-2KB-24.	BB24A.
1	Brake lever shaft.....	15-2KB-24.	BB24G.
1	Brake lever.....	13-28-23.	23G.
1	Brake lever catch.....	15-2KB-10.	BB10E.
1	Brake lever shaft bearing.....	13-28-23.	23A.
2	Brake band pin.....	15-2KB-8.	BB8AA.
1	Brake rod (right).....	13-28-23.	23M.
1	Brake rod (left).....	13-28-23.	23N.
2	Separator.....	13-28-23.	23R.
8	Bolts, $\frac{3}{8}$ by $4\frac{1}{2}$ inches.....	15-2KB-8.	BB8J.
2	Bolts, $\frac{3}{8}$ by 4.54 inches.....	15-2KB-16.	BB16M.
1	Pin, $\frac{3}{8}$ by $1\frac{1}{2}$ inches.....	15-2KB-24.	
36	Rivets, $\frac{3}{8}$ by $1\frac{1}{2}$ inches, copper.....	15-2KB-8.	
16	Rivets, $\frac{3}{8}$ by $\frac{1}{2}$ inch, copper.....	15-2KB-8.	
2	Split pins, $\frac{1}{4}$ by 2 inches.....	15-2KB-8.	
2	Handy oilers, 0.375 inch.....	15-2KB-16.	
2	Crown nuts, 0.875 inch.....	30-2-2.	Q2H.
2	Split pins, $\frac{3}{8}$ by 1.75 inches.....	30-2-6.	Q6A.B.
4	Brake rod end.....	13-28-23.	23Q.
1	Segment rack.....	13-28-23.	23K.
4	Brake band pin.....	15-2KB-8.	BB8AB.
1	Bushing.....	13-28-23.	23B.
2	Adjusting link.....	15-2KB-8.	BB8B.
2	Adjusting nut.....	15-2KB-8.	BB8F.
2	Crank, outer.....	15-2KB-16.	BB16N.
6	Lock washer (brake bolts).....	30-2-6.	Q6HC.
1	Bolt, 0.375 by 1.25 inches.....	13-28-23.	23D.
3	Bolts, $\frac{3}{8}$ by 1 inch.....	13-28-23.	23E.
2	Bolts, $\frac{3}{8}$ by $1\frac{1}{2}$ inches.....	13-28-23.	23L.
1	Bronze pin, $\frac{3}{8}$ by $\frac{1}{2}$ inch.....	13-28-23.	
1	Split pin, $\frac{1}{4}$ by $2\frac{1}{2}$ inches.....	13-28-23.	
1	<b>Pintle, complete, consisting of—</b>		
1	Pintle.....	15-2KA-26.	AB26A.
1	Pintle latch.....	15-2KA-10.	AB10B.
1	Pintle latch spring.....	15-2KA-19.	AB19C.
1	Pintle bearing.....	15-2KA-26.	AB26F.
1	Pintle spring.....	15-2KA-26.	AB26D.
1	Pintle spring seat.....	15-2KA-26.	AB26C.
1	Pintle nut.....	15-2KA-26.	AB26B.
2	Lock washer (pintle bearing bolt).....	30-2-6.	Q6FC.
1	Split pin, $\frac{1}{4}$ by $1\frac{1}{2}$ inches.....	15-2KL-16.	
1	Split pin, $\frac{1}{4}$ by $2\frac{1}{2}$ inches.....		
1	Nuts, 0.75 inch.....	30-2-6.	Q6H.
1	Bolt, $\frac{1}{2}$ by $3\frac{1}{2}$ inches.....	15-2KA-26.	AB26G.
1	Bolt, $\frac{1}{2}$ by $4\frac{1}{2}$ inches.....	15-2KA-26.	AB26H.
1	Pin, 0.984 by 2.875 inches.....	15-2KA-10.	AB10C.
1	<b>Lunette, complete, consisting of—</b>		
1	Lunette.....	15-2KA-9.	AB9B.
1	Lunette nut.....	15-2KA-9.	AB9C.
1	Lock washer.....	15-2KA-9.	AB9D.
1	<b>Prop, complete, consisting of—</b>		
1	Prop foot.....	15-2KL-16.	LB16D.
2	Prop tube.....	15-2KL-16.	LB16N.
1	Prop hook.....	15-2K-171.	C171A.
1	Prop eye (right).....	15-2KL-16.	LB16K.
1	Prop eye (left).....	15-2KL-16.	LB16L.
1	Prop chain.....	15-2K-171.	C171P.
2	Prop chain guide.....	15-2KL-16.	LB16H.
2	Prop chain clamp.....	15-2KL-16.	LB16O.
1	Prop chain button.....	15-2KL-16.	LB16E.
1	<b>Frame, complete, consisting of—</b>		
1	Side rail, right.....	13-28-21.	21A.
1	Side rail, left.....	13-28-21.	21B.
1	Middle rail, right.....	13-28-18.	18A.
1	Middle rail, left.....	13-28-18.	18B.
1	Middle rail, top plate.....	13-28-18.	18E.
1	Middle rail pocket.....	13-28-18.	18C.
1	Middle rail transom.....	13-28-18.	18D.
2	Tie rods.....	13-28-20.	20A.
1	Tie rod sleeve.....	13-28-20.	20D.
4	Side rail liners, right.....	15-2KA-23.	AB23E.
4	Side rail liners, left.....	15-2KA-23.	AB23F.
4	Carrying spring.....	15-2KA-21.	AB21C.
4	Spring bolt.....	15-2KA-31.	AB31F.
16	Belleville spring.....	15-2KA-21.	AB21B.
1	Lunette bracket.....	13-28-19.	19B.
2	Wheel guard.....	13-28-19.	19A.
1	Frame handle, right.....	15-2KM-6.	MB6F.
1	Frame handle left.....	15-2KM-6.	MB6G.
1	Shovel blade bracket.....	13-2B-20.	20G.

Num- ber.	Name of part.	Drawing.	Piece mark.
	Frame, complete, consisting of—Continued.		
1	Name plate.....	13-28-20.....	20E.
1	Axle.....	15-2KP-19.....	PB19A.
2	Axle bracket.....	15-2KA-23.....	AB23C.
4	Axle bracket bolts.....	30-2-6.....	Q6XA.
8	Nuts, 0.75 inch.....	30-2-6.....	Q6H.
6	Nuts, 0.375 inch.....	30-2-6.....	Q6C.
4	Crown nuts, $\frac{1}{2}$ by $\frac{1}{4}$ inches.....	15-2KA-31.....	AB31G.
4	Split pins, 0.25 by 2.75 inches.....		
4	Split pins, $\frac{1}{4}$ by 1.5 inches.....		
1	Bolt, $\frac{1}{2}$ by $9\frac{1}{4}$ inches.....	13-28-20.....	20C.
2	Screws, $\frac{1}{4}$ by $5\frac{1}{4}$ inches, flister head.....	13-28-20.....	20B.
4	Screws, $\frac{1}{4}$ by $3\frac{1}{2}$ inches, flister head.....	15-2KA-23.....	AB23D.
2	Wheel, 56-inch, complete, consisting of—		
16	Tire bolts, with nuts.....	15-2KP-9.....	PB9B.
8	Dowels.....	15-2KP-16.....	PB16G.
64	Felloe rivets and washers.....		
8	Felloe segment.....	15-2KP-52.....	PB52C.
16	Spokes, right.....	15-2KP-52.....	PB52A.
16	Spokes, left.....	15-2KP-52.....	PB52B.
32	Spoke shoes.....	15-2KP-9.....	PB9Q.
32	Spoke-shoe plates.....	15-2KP-9.....	PB9S.
40	Spoke-shoe rivets.....	15-2KP-9.....	PB9L.
2	Tires.....	15-2KP-9.....	PB9A.
2	Hub boxes.....	15-2KP-10.....	PB10A.
2	Hub liners.....	15-2KP-10.....	PB10B.
2	Hub rings.....	15-2KP-10.....	PB10D.
16	Carriage bolts (with nuts).....	15-2KP-9.....	PB9K.
2	Hub bands.....	15-2KP-10.....	PB10G.
2	Hub washers (lock).....	15-2KP-10.....	PB10E.
2	Hub caps.....	15-2KP-10.....	PB10L.
2	Hub latches with rivets.....	15-2KP-16.....	PB16A.
2	Hub latch springs.....	15-2KP-16.....	PB16B.
2	Hub latch plungers.....	15-2KP-16.....	PB16C.
2	Oil valves.....	15-2KP-5.....	PB5B.
2	Washers (oil valve).....	15-2KP-5.....	PB5C.
2	Oil valve rivet (bronze).....	15-2KP-5.....	PB5E.
2	Springs (oil valve).....	15-2KP-5.....	PB5A.
16	Washers (tire bolts).....	15-2KB-9.....	PB9C.
2	Wheel fastenings, complete, consisting of—		
2	Wheel fastening.....	16-2KP-10.....	PB10K.
2	Wheel fastening spring.....	15-2KP-16.....	PB16E.
2	Plugs.....	15-2KP-16.....	PB16F.
2	Wheel fastening plunger.....	15-2KP-16.....	PB16D.
2	Rivets.....	15-2KP-16.....	
1	Set steel rivets, complete, consisting of—		
4	0.125 by 1 inch, button head.....		
20	$\frac{1}{4}$ by $\frac{1}{4}$ inch, button head.....		
158	$\frac{1}{4}$ by $\frac{1}{4}$ inch, button head.....		
4	$\frac{1}{4}$ by $\frac{1}{4}$ inch, countersunk.....		
10	$\frac{1}{4}$ by $\frac{1}{4}$ inch, button head.....		
6	$\frac{1}{4}$ by $\frac{1}{4}$ inch, button head.....		
2	$\frac{1}{4}$ by $\frac{1}{4}$ inches, countersunk.....		
4	$\frac{1}{4}$ by $\frac{1}{4}$ inches, countersunk.....		
2	$\frac{1}{4}$ by $\frac{1}{4}$ inches, countersunk.....		
50	$\frac{1}{4}$ by $\frac{1}{4}$ inch, button head.....		
25	$\frac{1}{4}$ by $\frac{1}{4}$ inch, countersunk.....		
87	$\frac{1}{4}$ by $\frac{1}{4}$ inch, button head.....		
52	$\frac{1}{4}$ by $\frac{1}{4}$ inch, countersunk.....		
235	$\frac{1}{4}$ by $\frac{1}{4}$ inch, button head.....		
14	$\frac{1}{4}$ by $\frac{1}{4}$ inch, countersunk.....		
205	$\frac{1}{4}$ by $\frac{1}{4}$ inch, button head.....		
4	$\frac{1}{4}$ by $\frac{1}{4}$ inch, button head.....		
18	$\frac{1}{4}$ by $\frac{1}{4}$ inch, countersunk.....		
42	$\frac{1}{4}$ by $\frac{1}{4}$ inch, button head.....		
24	$\frac{1}{4}$ by $\frac{1}{4}$ inch, countersunk.....		
50	$\frac{1}{4}$ by $\frac{1}{4}$ inch, button head.....		
20	$\frac{1}{4}$ by $\frac{1}{4}$ inches, button head.....		
4	$\frac{1}{4}$ by $\frac{1}{4}$ inches, button head.....		
8	$\frac{1}{4}$ by $\frac{1}{4}$ inches, countersunk.....		
4	$\frac{1}{4}$ by $\frac{1}{4}$ inches, button head.....		
50	$\frac{1}{4}$ by $\frac{1}{4}$ inches, button head.....		
12	$\frac{1}{4}$ by $\frac{1}{4}$ inches, countersunk.....		
8	$\frac{1}{4}$ by $\frac{1}{4}$ inch, button head.....		
4	$\frac{1}{4}$ by $\frac{1}{4}$ inches, button head.....		
12	$\frac{1}{4}$ by $\frac{1}{4}$ inches, button head.....		
53	$\frac{1}{4}$ by $\frac{1}{4}$ inches, button head.....		
56	$\frac{1}{4}$ by $\frac{1}{4}$ inches, button head.....		
10	$\frac{1}{4}$ by $\frac{1}{4}$ inches, button head.....		
4	$\frac{1}{4}$ by $\frac{1}{4}$ inches, button head.....		
12	$\frac{1}{4}$ by $\frac{1}{4}$ inches, button head.....		
4	$\frac{1}{4}$ by $\frac{1}{4}$ inches, button head.....		

## DESCRIPTION.

The headquarters instrument cart, Plate XXXVI, is a two-wheeled vehicle made of metal throughout with the exception of the wheels and the packing within the chest. It is designed to carry part of the fire-control equipment for the organization to which it is attached.

The principal parts are the wheels, axles, frame, road brake, chest and chest-supporting device.

The wheels are of the standard 56-inch ordnance pattern and are the same as and interchangeable with those upon the reel.

The frame consists of a middle rail, side rails, and axle brackets. The middle rail is formed from two flange steel channel sections, riveted together and strengthened by a top plate and transoms; it is fitted in the rear with a pintle and pintle bearing and in the front with a lunette bracket. The two side rails are riveted one on each side beneath the chest. Their function is to support the chest and convey the weight of the load through the chest-supporting device to the axle.

The chest-supporting device consists of two spiral carrying springs beneath each side rail and interposed between the side rails and axle brackets clamped to the axle. The springs are mounted on bolts which are fastened in the side rails and which pass through holes in the axle brackets. Between nuts on the lower ends of the bolts and the axle brackets are assembled Belleville springs. The carrying springs absorb the excess vertical loads when traveling over rough ground and the Belleville springs absorb the load due to the rebound.

The road brakes are of the contracting band type and may be operated from the front of the cart or from the operator's seat on top of the chest by means of a brake lever on the right side. The brake bands are held in position by clips, which in turn are fastened to brake hangers on the axle arms. Contraction of the bands upon drums bolted to the wheels is accomplished from the lever through a linkage and a brake shaft.

The instrument chest is made of flange steel plates shaped and riveted together and fitted with doors, lock bars, and packing devices. The principal components are: A chest body, a chest frame, transoms, bottom plates, chest cover plate, intermediate plates, chest front, front door, rear door, door boxes, and lock bars. The interior is made up into 17 compartments of different sizes. Several of the compartments are designed to receive wooden chests or packing boxes, which are fitted with felt pads and spiral springs to support and retain in place certain of the fire-control instruments. A list of the compartments glued on one of the rear door compartments indicates the contents of each compartment, but the arrangement of the boxes in the compartments and of the equipment in the boxes as listed is

not obligatory and may be altered as the requirements of the service necessitate.

The chest is finished with fixtures for attaching an observation tower and for maneuvering it for transport and use.

A steel instrument chest to carry additional fire-control equipment for which there is no space provided in the chest on the cart is furnished and may be stowed upon an artillery supply truck or staff observation car for transport.

## **OILS, LUBRICANTS, AND CLEANING MATERIALS.**

### **ENGINE OIL NO. 1.**

Engine oil No. 1 is issued for general lubricating purposes, for bearings, sliding surfaces, breechblocks, breech boxes, and in general, for all bearings not provided with compression grease cups.

### **NO. 4½ LUBRICANT.**

No. 4½ lubricant is a heavy mineral oil issued for use on the heavy bearings of carriages, such as the gun trunnions, etc., and is to be used in connection with the compression grease cups provided.

### **FLAKE GRAPHITE, DIXON'S STANDARD NO. 1.**

Flake graphite, Dixon's Standard No. 1 or equal, is issued for use with the No. 4½ lubricant. The purpose of this admixture is to form a more durable lubricant for very heavy bearings, and one which will not permit so much friction and consequent cutting of the bearings in cases where the compression grease cups have inadvertently been allowed to become empty, as would the No. 4½ lubricant if used alone. The graphite should be mixed with the No. 4½ lubricant by kneading and without heating the latter, as heating destroys its viscosity. The proportions to be used are 95 per cent of No. 4½ lubricant to 5 per cent of graphite by volume.

### **DIXON'S SPECIAL CARRIAGE GRAPHITE GREASE.**

This is a special prepared mixture of flake graphite and grease. It is used for the lubrication of recoil guides when guides are not provided with oil grooves or grease cups. It is used also for the lubrication of counterrecoil spring systems. For this latter purpose experience has shown it to be the best lubricant yet devised.

### **CLOCK OIL.**

Clock oil is issued, in bottles containing 1 fluid ounce, for lubricating the delicate bearings of the telescopic sights, position finders, panoramic sight, and elevation quadrant. This oil should be applied by dropping from the end of the dropper attached to the cork.

## HYDROLINE.

Hydrolin is a chemically neutral mineral oil issued for use in the recoil cylinders of the carriages. It is required to be entirely free from signs of acid and alkali at all ordinary temperatures, to show a specific gravity of between 0.835 and 0.87 at 60° F., to be free from ash, saponifiable oil, and to show no signs of decomposition up to 200° F. It is also required to pass a specific viscosity test and a cold test of 0° F. This oil is issued for use in the recoil cylinder and should be used for no other purpose.

Great care is taken to obtain a superior and uniform grade of this oil in order to insure uniform recoil action. It is evident that similar care should be exercised by the service to keep this oil separate from all other oils and to see that storage conditions are such as to prevent any adulteration from old Hydrolin, moisture, sediment or other oils.

Hydrolin is issued in 5-gallon tin cans provided with screw caps.

When Hydrolin is drawn off from recoil cylinders it should be strained through a piece of fine cloth in order to remove the coarser sediment and should then be allowed to stand in a covered can for not less than 24 hours before used. In drawing off old Hydrolin the supply should always be removed from the top of the storage receptacle to avoid including any sediment which may have settled. Mere discoloration of old Hydrolin is not an indication of unserviceability.

Recoil cylinders should never be left empty, as, when in that condition, they will dry and rust. Any leakage from the cylinder should be promptly replaced.

## GLYCERINE AND WATER.

A mixture of glycerine and water (50 per cent each) is used in the recoil brake mechanisms of matériel of Schneider design; viz., 155-mm. howitzer, model of 1918. This mixture is prepared as follows: Neutral glycerin (25° Baumé), 50 per cent; pure water, 50 per cent. The specific gravity of the mixture should be 21° Baumé at 59° F. (15° C.). The mixture should be boiled for 15 minutes.

For use in the recuperators of the above matériel, a mixture, similar to that for the recoil brake, but with the addition of 4 per cent of chemically pure commercial caustic soda is used. This mixture should not be boiled.

The glycerine used in these two mixtures must be neutral. Test it with litmus paper, which should not turn red on being immersed in the mixture. If it shows red, titrate with chemically pure commercial caustic soda (NaOH) and stir until the acid is neutralized.

## SLUSHING OILS.

Light slushing oils are issued for the preservation of bright metallic surfaces when the carriage and gun are out of service. This oil is essentially a mineral oil but may contain resin. It is required to be free from animal and vegetable oils, from mineral acid, and from all substances which would corrode metal. It is also required that the consistency be such as to allow the application of the oil by means of a brush at all ordinary temperatures.

A thin coat of this oil applied to the bright surfaces will give good protection. In very cold weather, when the oil is somewhat stiff, it should be applied by holding the brush perpendicular to the surface to be coated and tapping the same with the point of the brush. Before application of the oil is made, care should be taken to see that the surface to be coated is free from rust, water, kerosene, and lubricating oil.

Before applying slushing oil to the bore of the guns, after firing, the bores should first be washed out with clean water, drained, and made perfectly dry.

Light slushing oil may be used on all bright surfaces of guns except the breechblock and breech box, which should be oiled with Engine oil No. 1. When a gun is out of service, however, light slushing oil may be applied to the breechblock and breech box, provided this coating is removed before the gun is fired.

If slushing oil is applied less than 30 hours before subjected to a heavy rain, the surfaces so coated should be examined to make sure that the moisture has not penetrated the coating.

To remove this oil, the greater part of the coating should be taken off by means of a scraper and the balance removed by using a rag or cotton waste moistened with kerosene. A hot solution of water and lye will also loosen the oil and render it easy to remove.

As a rule, light slushing oil may be sufficiently removed from the bore to permit of firing by means of scraper alone, but when the bore is to be thoroughly cleaned preparatory to star-gauging or other critical examination use must be made of the bore sponge covered with burlap moistened with kerosene or a solution of lye and water. After nearly all the oil has been removed in this manner a clean covering of burlap should be put on the head of the bore sponge and this covering moistened with kerosene and sprinkled with Lavaline for use in the final cleaning.

## KEROSENE (COAL OIL).

Kerosene is issued in 5-gallon tin cans, for cleaning purposes only. It should be used in connection with the plumber's force pump supplied to each post for flushing out and cleaning the interior of recoil

cylinders. It should also be used on the burlap covering of the special bore sponge when removing light slushing oil from the bores of the guns. Kerosene will also be found useful in cutting and loosening any oil which has become dry and gummy. In order to make the allowance of kerosene go as far as possible, use should be first made of a scraper in removing light slushing oil, the remainder may be removed with a rag or wad of cotton waste and moistened with kerosene.

#### MISCELLANEOUS CLEANING MATERIALS.

Emery cloth No. 00 is issued for use in cleaning bright metallic parts of guns and their carriages. No coarser abrasive than this should be used on breechblocks or breech boxes. In removing rust it will be found that if the rusted part be first moistened with kerosene for an hour or so that the subsequent cleaning of the part with emery cloth will be facilitated.

Emery cloth No. 1 is for use in cleaning bright metallic surfaces. No coarser abrasive than this should be used on the piston rods of any carriage.

Lavaline is an abrasive scouring material in powdered form. It is provided for general scouring purposes on bright surfaces of guns and carriages where a coarser material is not needed. It will be found especially useful in cleaning the bores of guns preparatory to star-gauging or other critical examination. In using this substance it should be applied on a rag, burlap, or cotton waste, moistened with kerosene and rubbed vigorously.

Putz pomade is the mildest of the abrasives issued and is intended for use in polishing brasses and other polished surfaces. It should be applied with a soft rag or old chamois skin, rubbing vigorously.

The sash tool No. 6 is used in applying light slushing oil.

A plumber's force pump is issued for the spraying of kerosene oil into the recoil cylinders when they are being cleaned.

A painter's duster No. 2 is for use in dusting surfaces which are about to be painted.

## **PART II.—INSTRUCTIONS FOR THE CARE, MAINTENANCE, AND OPERATION OF THE MATÉRIEL.**

### **MANEUVERING THE CARRIAGE.**

In traveling, the rear end of the trail is carried on the 155-mm. howitzer carriage limber, model of 1918 (Schneider). In order to properly distribute the weight the howitzer is retracted and locked in traveling position. The carriage is locked in the center of its traverse to relieve the traversing screw of excessive strains.

#### **HOWITZER IN TRAVELING POSITION.**

Place the carriage in the center of its traverse. Turn the axle traveling lock to traveling position. Place the cradle traveling locks at traveling position and elevate the howitzer until the rear cradle band engages the cradle locks. Place the sleigh locks in traveling position. Open the cradle front cover and push down the lock lever until the piston rod nuts are disengaged. Attach the retracting tackle to the retracting eye of the howitzer and the lunette fastening, and retract the howitzer until the sleigh locks have entered the grooves on the sleigh. (This eliminates the possibility of pulling the sleigh off the cradle.) Then turn the sleigh locks out a sufficient distance to clear the obstruction and move the howitzer back into traveling position. Turn the traveling locks back into traveling position. Lift up the lock lever, close the front cradle cover, and remove retracting tackle.

#### **HOWITZER IN BATTERY.**

Open the front cradle cover and push the lock lever down. Attach the retracting tackle to the eyebolt provided for that purpose on the shield and the front eyebolt on the breech counterweight. Turn sleigh lock to firing position and pull the howitzer into battery. Lift up the lock lever until the piston rod lock engages the piston rod nuts. Close and lock the cradle front cover. Turn the cradle lock to firing position. Turn the axle traveling lock to firing position.

### **CARE AND MAINTENANCE OF THE MATÉRIEL.**

#### **OILS AND GREASES.**

The battery equipment includes lubricating oil, clock oil, coal oil, light slushing oil, soft grease, and glycerin. Each of these oils is issued for a particular purpose, as heretofore stated, and should not

be used for any other purpose. The use of any oil other than those prescribed is prohibited. The use of pumice, emery powder, or any other abrasive is prohibited. The polishing of any part of the carriage is also prohibited.

Lubricating oil will be used exclusively in all oil holes (Plate XLVI) and in lubricating such parts as wheels and axles, cradle and sleigh slides, elevating and traversing mechanism, exterior of cylinders, brake bearings and hinges.

Clock oil should be used on the spindles and bearings of the fuze setter, quadrant sight, and all optical instruments. The oil should be applied only when the instruments are dismantled for cleaning and should be applied from the end of a dropper. Care should be taken to remove all oil from the lenses of optical instruments with a chamois cloth.

Coal oil (kerosene) is issued by the Ordnance Department for cleaning purposes only. In the field it may be used for lanterns. (Coal oil for general illuminating purposes is issued by the Quartermaster Corps.)

Light slushing oil is prescribed for use in the protection and preservation of all bright or unpainted surfaces of steel or iron when the material is to remain unused for an appreciable time. Its use as a lubricant for mobile artillery is forbidden. Before applying the slushing oil to any surface the part should be thoroughly cleaned so as to be free from rust, water, coal oil, lubricating oil, etc., as their presence will cause rusting under the slushing oil. The slushing oil should be applied in a thin, uniform coat. Except in very cold weather, it can be applied with a paintbrush. In cold weather it should be applied by stippling, that is, lightly tapping the surface with the end of the brush held with the bristles perpendicular to the surface to be covered. In cold weather it should be warmed before use. It may be readily removed by the use of burlap or waste dipped in coal oil.

Soft grease is used in the elevating and traversing gear box and in the gear cases of the sight.

A mixture of glycerin and water is issued for use in the recoil and counterrecoil mechanism and for no other purpose. It should be stored in air-tight cans provided for that purpose and carefully protected from dirt or dust.

#### CARE OF THE HOWITZER.

When not in use the muzzle and breech should be protected by canvas covers provided for that purpose.

The breech mechanism and all working parts should be kept clean and well lubricated at all times. The breech, firing, and percussion mechanisms should be dismantled periodically for cleaning and oiling

Kerosene is issued for cleaning purposes only and should be applied with a soft rag or cotton waste. Care should be taken to thoroughly remove kerosene before lubricating, as the presence of kerosene under lubricating oil will cause rusting. Engine oil No. 1 is provided for lubricating purposes and in general for oiling all bearings and moving surfaces not provided with compression grease cups.

After firing periods, the bore of the howitzer should be cleaned to remove the residue of smokeless powder, and thoroughly oiled. In cleaning, wash the bore with a solution made by dissolving one-half pound of sal soda in 1 gallon of boiling water. After washing with the soda solution, wipe perfectly dry, and oil the bore with a thin coating of light slushing oil furnished for this purpose. The vent and primer seat should also be thoroughly cleaned with the tools provided for that purpose.

Should difficulty be encountered in opening or closing the breech the matter should be reported to the chief mechanic or commissioned officer who will give the necessary directions for removing the trouble. The breechblock should never be forced shut.

#### CARE OF THE CARRIAGE AND OTHER VEHICLES.

The matériel should be thoroughly cleaned and oiled at intervals not exceeding two weeks and as soon as possible after each firing period. This should be done in accordance with the following directions, and using only the oils prescribed. Oil holes which may have become clogged with congealed oil should be cleaned with a piece of wire. Wood should never be used for this purpose, as splinters are likely to break off and clog the oil holes. Oil should be applied by means of the grease gun to all the oil holes shown on Plate XLVII. Thoroughly clean and oil the elevating segments and pinions. Operate the elevating and traversing mechanisms through the full extent of their travel. If either gear operates harder than usual they should be overhauled and the cause removed.

The exposed part of the sleigh slides when the howitzer is in battery should be thoroughly cleaned with coal oil and oiled, the howitzer pulled out of battery, and the front end of the slides cleaned with coal oil and oiled. See that all oil holes on the sleigh are filled with oil.

To clean the axle, place the howitzer in battery, if it is not already in that position, and clean the visible parts of the axle by successively traversing the carriage to the full extent of its travel to the right and left. Oil the rollers in the roller boxes and see that the oil holes are clean and filled.

Grease the lunette with heavy grease provided for that purpose.

To grease the carriage wheels, remove the linch pin and axle cap, to which the wheel oil valve is attached, and see that the oil passages are clean. With the aid of the grease gun fill the oil cavity in the axle with grease and replace the wheel oil valve, axle cap, and linch pin.

**TO GREASE LIMBER AND CAISSON WHEELS.**

To grease the caisson wheels, pull out the wheel oil valve and turn it so that it stays in open position. With the grease gun fill the oil cavity in the hub cap with grease.

To grease the limber wheel, remove the grease plug and with the grease gun fill the cavity in the hub with grease.

**CARE OF THE RECOIL AND COUNTERRECOIL MECHANISM.**

The recoil cylinder should be kept full of liquid and the proper quantity of liquid and pressure maintained in the counterrecoil system at all times. An insufficient quantity of liquid in the recoil cylinder has the effect of increasing the pressure at the beginning of recoil, causing excessive stress in the cylinder walls. A large void in the recoil cylinder may result in the breaking of the piston rods and the howitzer being put out of action. An insufficient pressure or quantity of liquid in the counterrecoil system has the effect of not completely returning the howitzer to battery.

When the howitzer is in action the length of recoil, Plate XX, should be constantly checked by means of the recoil indicator. This may be done by placing chalk, grease, or white lead on the edge of the sleigh and screwing up the adjusting nut of the indicator until the index touches the sleigh and measuring the length of the trace when the howitzer has returned to battery. The following table gives the proper length of recoil at various elevations:

Angle of elevation.	Powder charge.													
	7		6		5		4		3		2		1	
	Meters.	Inches.	Meters.	Inches.	Meters.	Inches.	Meters.	Inches.	Meters.	Inches.	Meters.	Inches.	Meters.	Inches.
10...	1.26	49.6	1.22	48.0	1.00	43.3	1.01	39.8	0.94	37.0	0.85	33.5	0.77	30.3
20...	1.28	50.4	1.24	48.8	1.14	44.9	1.05	41.3	.97	38.2	.89	35.0	.81	31.9
40...	1.30	51.2	1.25	49.2	1.17	46.1	1.10	43.3	1.02	40.1	.95	37.4	.87	34.2

If the howitzer over recoils or does not return to battery, after making sure that the recoil cylinder contains the proper volume of liquid, the pressure in the counterrecoil system should be verified. If the pressure is less than the normal value; as shown on the pressure correction plate which is located on the underside of the cradle front cap, Plates XVII and XXXVIII, reestablish it by the addition of more gas and measure the recoil again. In general, after this is done the recoil will be within the allowances fixed by the table. If the length of recoil is still too great, measure the amount of liquid in the counterrecoil system. If this test shows the amount of liquid to be



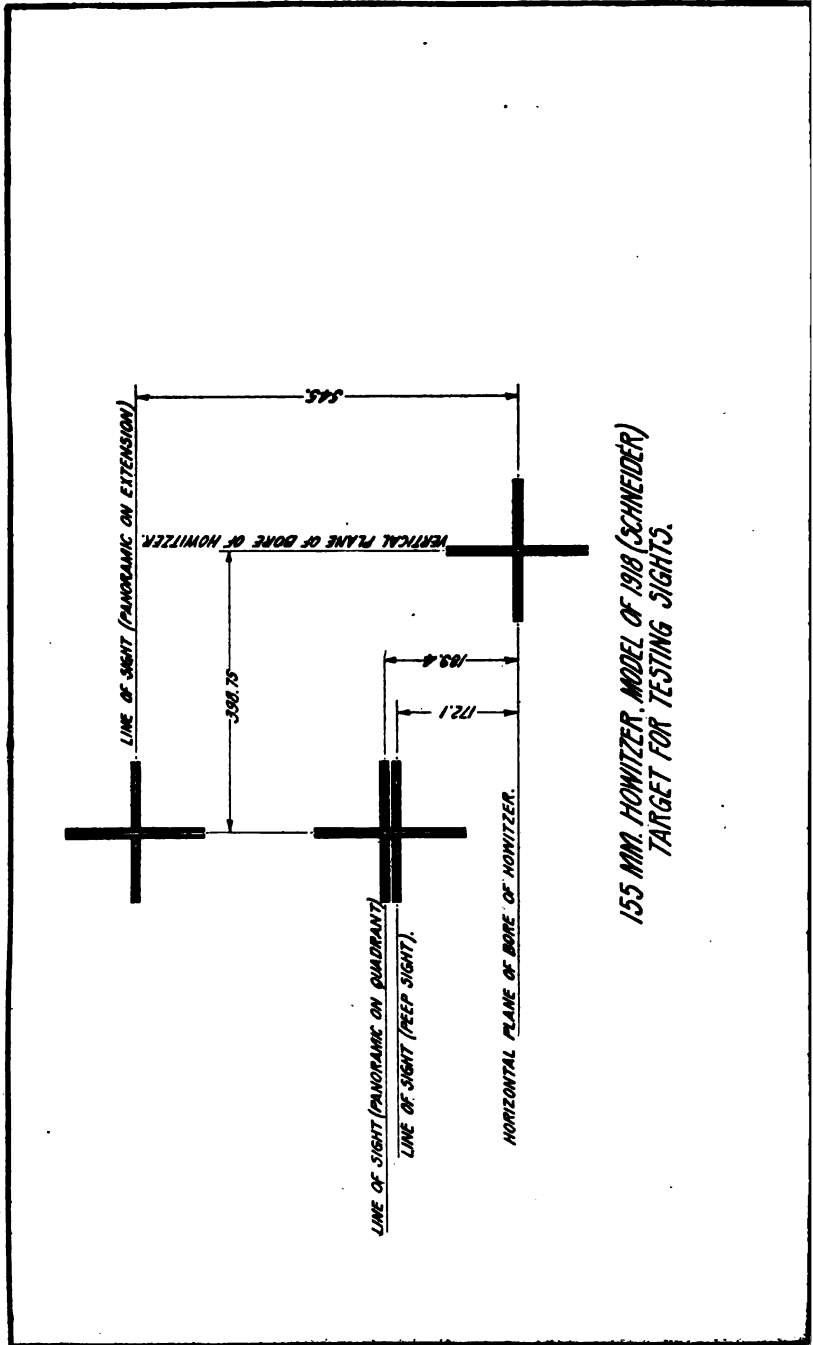

155 MM. HOWITZER, MODEL OF 1918 (SCHNEIDER)  
TARGET FOR TESTING SIGHTS.

insufficient, reestablish the normal level. If the recoil is still too long, call it to the attention of the mobile repair unit. At the same time, examine the measuring instruments and have them tested.

When the howitzer is not in action the volume of liquid in the two cylinders and the pressure in the counterrecoil cylinder should be periodically checked, and when possible, before each firing period.

The recoil and counterrecoil cylinders should be emptied and refilled at periods not exceeding three months. They should be thoroughly cleaned and refilled once in six months or oftener if occasion demands. This operation is to be done by the mobile repair unit. Battery mechanics are not allowed to open the recoil mechanism under any conditions, or do any work on the recoil mechanism other than that specifically detailed to them.

#### CORRECTION PRESSURE PLATE.

Temperature.		Maximum pressure.		Minimum pressure.	
		Kg per sq.cm.	Lb per sq.in.	Kg per sq.cm.	Lb per sq.in.
°C.	°F.				
50	122	37.0	526.3	35.8	509.2
45	113	36.4	517.7	35.3	502.1
40	104	35.8	509.2	34.7	493.5
35	95	35.3	502.1	34.2	486.4
30	86	34.7	493.5	33.6	477.9
25	77	34.1	485.0	33.1	470.8
20	68	33.6	477.9	32.6	463.7
15	59	33.0	469.4	32.0	455.1
10	50	32.4	460.8	31.4	446.6
5	41	31.9	453.7	30.9	439.5
0	32	31.3	445.2	30.3	431.0
- 5	23	30.7	436.7	29.8	423.9
-10	14	30.1	428.1	29.2	415.3
-15	5	29.5	419.6	28.7	408.2

The outside of the recoil cylinders should be kept thoroughly oiled to prevent rusting. They should be inspected periodically and any signs of rusting immediately removed.

#### TO MEASURE THE PRESSURE AND LIQUID IN THE COUNTER-RECOIL SYSTEM.

Elevate or depress until the howitzer is dead level. If the wheels are not on level ground, jack up one wheel until the axle is dead level. It is important that the howitzer should be level in both directions. Otherwise erroneous readings will be obtained. Open the cradle head cap, Plate XIX. Remove the plug nut, gage cock body head, and front gage cock body plug. Assemble the pressure gage adapter and tighten up on the pressure gage adapter union. By means of the gage cock wrench turn the gage cock body until the pointer points below the normal level. Screw in the adapter handle, opening the valve, and read the pressure directly from the gage. If this pressure is below normal, reestablish it by introducing

gas into the system. If it is above normal, open the adapter needle valve, allowing the gas to escape until the desired pressure is reached. To test the level of the liquid, screw in the adapter handle, opening the valve, and tap the adapter needle valve. By means of the gage cock wrench turn the gage cock body in a counter-clockwise direction until the liquid begins to flow from the port in the bottom of the pressure gage adapter, then close both valves. If the indicator now points between 0.5 above and 0.5 below the zero line on the scale, the liquid may be considered at the proper level. If the indicator points outside of these limits, pump in or drain off as directed on the scale. Remove the pressure gage adapter and close the cradle front cap.

#### **TO ADD GAS TO THE COUNTERRECOIL MECHANISM.**

Open the cradle bottom cover, Plate XIX. Remove the filling valve cap and the filling needle valve cap. Assemble the long swivel and swivel nut on the filling valve and screw the nipple on the swivel. Mount the air pump on the pump bracket and attach the short swivel nut of the filling pipe marked "Reservoir" to the pump and that marked "Sleigh" to the nipple. Open the filling needle valve by means of the filling needle valve wrench and pump in air until the desired pressure is indicated on the gage. See that the needle valve is tightly closed, remove pump and filling pipe, replace filling valve and filling needle valve caps, and close cradle bottom cover.

When it is necessary to entirely empty the counterrecoil cylinder, it should be recharged with nitrogen from the nitrogen cylinder carried in the artillery supply truck. (*Nitrogen is preferable to air because it contains no corrosive elements.*) When nitrogen is not available air may be pumped in as directed above.

To charge from the nitrogen retainers, proceed as follows: Remove caps and assemble swivels and nipple as above. Attach flexible filling pipe to the nipple and nitrogen retainer outlet by means of the two short swivels. Gradually open nitrogen retainer needle valve until desired pressure is indicated on the gage. Disassemble the equipment as above and close cradle bottom cover.

Gas should never be added to the system without first assembling the pressure gage and opening the pressure valve.

#### **TO ADD LIQUID TO THE COUNTERRECOIL MECHANISM.**

Mount the liquid pump on the pump bracket and assemble in the same manner as the air pump, Plate XXVI. Pump in the counter-recoil liquid until the proper level is reached. When the pumps and measuring instruments are not in use they should be packed in their proper place and the cradle covers closed and locked.

**TO ADD LIQUID TO THE RECOIL CYLINDER.**

Depress the howitzer as far as possible. By means of the filling plug wrench, remove the filling plug, Plate XVIII, from the recoil cylinder head, attach the funnel pipe and funnel, and pour in liquid until it commences to overflow. Return the howitzer to horizontal position, allow about 100 cubic centimeters (6.1 cubic inches) to flow out. See that the gasket is in good condition and replace the plug.

**DAILY INSPECTION.**

The howitzer and carriage should be inspected daily by the gun crew to discover any points which need attention or adjustment.

Open and close the breech to see that it operates freely. See that the obturator is in good condition and that the threads are not scored.

Examine the bore to see that it is free from rust or foreign matter and well slushed.

See that the holding-down band keys are in place and that the nuts are tight with split pins in place.

See that the percussion hammer operates freely and strikes the firing pin properly.

See that the firing mechanism housing can be freely removed and inserted and that the vent and primer seat are free from foreign matter.

See that all working parts of the breech are well lubricated and that all metal surfaces are well slushed.

Elevate and depress the howitzer through the full extent of its travel to see that the mechanism operates without binding or undue backlash.

Traverse the howitzer to right and left through the full extent of its travel to see that the mechanism operates without binding or undue backlash.

See that all traveling locks operate freely.

See that the road brake operates freely and that the brake shoes bear on the tires when the brake is set.

See that the cradle clips are free from foreign matter and well greased.

See that the panoramic sight is in its case if not in use and that the lenses are clean and free from moisture or oil.

See that the tools and accessories are in their proper places.

Open the cradle head cap and see that the gage cock pointer points between +5 and -5.

See that the cradle cover bottom is closed and latched.

See that all working parts are well lubricated and that all metal surfaces are well slushed.

Examine the limbers and caissons to see that brake bands are in good condition, that all nuts are tight with split pins in place, that all working parts are well lubricated, and that all metal surfaces are well slushed.

Directions for maintenance and inspection of other battery and regimental vehicles are given in their respective handbooks.

## **INSTRUCTIONS FOR REPAIRS AND REPLACEMENTS.**

### **DUTIES OF THE GUN CREW.**

The gun crew is authorized to make only minor repairs and such replacements as are herein designated. The work should be done in accordance with the following directions, and any difficulties which can not be remedied should be referred to the battery mechanics of mobile repair shop.

The gun crew is strictly forbidden to dismantle any part of the recoil or counter-recoil mechanism.

#### **TO DISMANTLE THE FIRING MECHANISM.**

Remove the firing mechanism block, and take out the firing pin housing holding screw. Take out the firing pin housing with a teat wrench and slip out the firing pin and spring. Remove the primer seat plug with a teat wrench and slip out the firing pin guide.

#### **TO ASSEMBLE THE FIRING MECHANISM.**

Place the firing pin guide in the front end of the firing mechanism block and replace the primer seat plug with the aid of a teat wrench. Place the firing pin spring and firing pin in position, replace the firing pin housing, using a teat wrench to screw it home, and replace the firing pin housing holding screw.

With the breech closed and locked, replace the firing mechanism block.

#### **DISMANTLING THE PERCUSSION MECHANISM.**

With the breech closed, remove the percussion hammer operating shaft nut and percussion hammer operating shaft collar. Pull the percussion hammer operating shaft out of its bearing to the right, allowing the percussion hammer to drop out. Open the breech and remove the percussion hammer shaft plunger and spring.

#### **ASSEMBLING THE PERCUSSION MECHANISM.**

With the breech open replace the percussion hammer shaft plunger spring and plunger. Close the breech and slide the percussion hammer operating shaft into its bearings from the right, passing it through the percussion hammer. Replace the percussion hammer operating shaft collar and nut.

**DISMOUNTING THE CRADLE TRAVELING LOCKS.**

With the howitzer in firing position, drive out the pins which hold the cam screws in place, remove the cam screws and slip out the cradle traveling locks.

**ASSEMBLING THE CRADLE TRAVELING LOCKS.**

With the howitzer in firing position put the cradle traveling locks in place, being sure that the flat surface of the cylinders are up when the handles are in traveling position. Replace the cam screws and pins and rivet the ends of the pins cold.

**DISMOUNTING THE SLEIGH TRAVELING LOCKS.**

Put the howitzer in battery if not already in that position. Remove the split pins, which hold the cam screws in place. Take out the cam screws and slip the traveling locks out of their bearings.

**ASSEMBLING THE SLEIGH TRAVELING LOCKS.**

With the howitzer in battery, place the proper traveling locks (left and right) in their bearings, with the handles pointing between direction plates and cam screw slots toward the front of the carriage. Put the cam screws in place, being sure that they engage in the slots, and replace split pins.

**REMOVING THE CARRIAGE WHEEL.**

Traverse the howitzer to the full extent of its traverse to the side opposite the wheel to be removed. Place the jack under the axle as near as possible to the wheel. It is important that a block of wood be placed between the axle and the head of the jack to prevent scoring the axle.

Remove the linch-pin fid, pull the free end of the linch-pin latch away from the wheel and pull out the linch pin. Remove the axle cap with wheel oil valve attached to it; remove the outer leather washer and pull off the wheel. Remove the inner leather washer and axle collar.

**REPLACING THE CARRIAGE WHEEL.**

Replace the axle collar and inner leather washer and slip the wheel in place. Replace the outer leather washer and axle cap with the wheel oil valve attached. Replace the linch pin, push the linch-pin latch back into position and replace the linch-pin fid.

**REMOVING THE CAISSON CONNECTING POLE.**

Place a jack under the front end of the pole socket, loosen the pole-socket bolt, remove the split pin from the connecting pole key and remove the connecting pole key, driving it out if necessary. Remove the split pin from the pole pin, remove the pin and pull the pole out of its socket.

**REPLACING THE CONNECTING POLE.**

Place the connecting pole in the pole socket with the pole prop down, and replace the connecting pole key and pole pin. Replace the split pin and tighten up the pole-socket bolt.

The horse pole is applied to the caisson as directed above except that the doubletree adapter is placed in the groove on top of the pole socket and the connecting pole key is passed through the square lugs on top of the pole socket, holding the doubletree adapter in place.

**DISMOUNTING THE PINTLE.**

Remove the split pins, nuts, and bolts which hold the pintle bearings in place. Pull the pintle and bearing out of the pintle-bearing supports and remove the two halves of the bearing.

The pintles of all battery and regimental vehicles except the carriage limbers are identical.

**ASSEMBLING THE PINTLE.**

Place the two halves of the pintle bearing around the pintle and slide the unit between the pintle bearing supports. Replace the bolts, nuts, and split pins.

**REMOVING A CAISSON WHEEL.**

With the caisson prop down and the brake released, place a jack under the chest on the side near the wheel to be removed. If possible, it is advisable to place a timber between the bottom of the chest and the head of the jack. It is important that the center of the jack should be slightly to the rear of the centerline of the axle, otherwise the caisson may tip over backward. Pull out the hub latch and with the spanner wrench remove the hub cap. Lift the wheel fastening from its seat on the end of the axle and pull off the wheel. Care should be taken not to damage the brake band in removing the wheel.

**REPLACING THE WHEEL.**

With the chest jacked up as above, place the wheel on the axle, being careful to slip the brake drums into the band without damaging the latter. Replace the wheel fastening and, holding the hub latch out, screw on the hub cap with a spanner wrench until it is made up tight. Then back off the hub cap until the hub latch seats in the hole in the hub band.

**REMOVING A LIMBER WHEEL.**

Jack up one side of the limber, placing the jack under the outer end of the axle, just inside of the wheel which is to be removed. The connecting pole should be allowed to rest on the ground. Do not

attempt to jack up one side with the front end supported on the pole prop unless the vehicle is equipped with horse pole. Remove the linch pin and axle cap and pull the wheel off.

#### REPLACING THE WHEEL.

With the axle collar, dust collar, and inner washer in place, slip the wheel in place. Replace the outer washer, axle cap, and linch pin, and tie the linch-pin fid.

#### CARE OF THE SIGHTS.

The quadrant sight should be carried mounted in the left trunnion of the carriage at all times, and when not in use should be covered by the sight cover to protect it from the weather. When not in action the panoramic sight should be packed in the panoramic sight case, which is mounted on the upper left-hand corner of the rear side of the shield.

The sights are delicate instruments and must not be subjected to any rough usage, jars, or strains. To obtain satisfactory vision the lenses must be perfectly clean and dry. The T lug on the panoramic sight and its slot in the shank of the quadrant sight and sight extension should be kept lightly oiled to prevent rusting. In the panoramic sight the exposed optical elements and all nonmovable joints are sealed and no attempt should be made to remove them.

#### DUTIES OF THE BATTERY MECHANICS.

##### THE HOWITZER.

Should difficulties be encountered in closing the breech the cause should be found and removed. The breech must never be forced shut. Difficulties of the above nature will generally be caused by expanding of the obturator or fouling or burring of the threads at the time of loading. Should the obturator become expanded it should be replaced with a new one. If the threads are found to be burred, the burr should be smoothed down with a file, great care being taken not to remove any part of the threads.

Should difficulties be encountered in opening the breech place a piece of wood or bar of soft copper against the left end of the rack and tap lightly with a hammer, at the same time pulling back on the operating lever. Care should be taken not to use sufficient force to damage the teeth on the breechblock or rack. When the breech has been opened examine the threads carefully and remove the cause of the difficulty.

In dismantling and repairing the breech mechanism, battery mechanics are cautioned against using tools other than those provided by the Ordnance Department for that purpose. Extreme care should

be taken to see that all parts are thoroughly cleaned and free from grit or other foreign matter before reassembling.

**TO DISMANTLE THE BREECH MECHANISM.**

Place the howitzer at approximately zero elevation, remove the firing-mechanism block, and open the breech. Press down on the firing-mechanism housing key spring and pull the firing-mechanism housing key as far back as it will go. Unscrew the obturator spindle with the wrench provided for that purpose and pull the spindle out of breechblock. Remove the gas check pad split rings and filling-in disk. Pull the firing-mechanism housing and firing-mechanism housing key out of the hub of the block carrier. The firing-mechanism housing key will then drop out of the firing-mechanism housing. Remove the firing-mechanism housing screw, firing-mechanism safety plunger, and firing-mechanism safety plunger spring. Unscrew the obturator spindle plug with the obturator spindle plug wrench and remove the spindle plug gasket. The obturator spindle vent bushing can not be removed in the field.

Remove the detent and operating lever collar from the lower end of the pintle of the operating lever. Raise the operating lever a sufficient distance to disengage the lug which operates the rack, at the same time lifting up on the breechblock to take the weight off the pintle, and block the operating lever up with a piece of wood. Press the rack lock into the block carrier as far as it will go and pull the rack out of the block carrier. Remove the rack lock and rack lock spring. Screw the breechblock out of the block carrier and remove the obturator spindle spring and spindle spring front and rear seats.

Lift the operating lever up, pulling the pintle out of the hinges, and remove the block carrier. Take out the block carrier hinge bearing plates, regulating plate, and nut for regulating plate.

To dismantle the operating lever latch remove the operating lever handle nut with a teat wrench and lift off the operating lever handle sleeve. Take out the operating lever handle key and remove the operating lever handle and spring. Pull the operating lever latch out through the handle end of the lever.

If desired the breech mechanism can be removed from the howitzer as a unit.

**TO ASSEMBLE THE BREECH MECHANISM.**

Assemble the operating lever as follows: Insert the operating lever latch in the operating lever, long end first, replace the operating lever handle spring, operating lever handle, and operating lever handle key. Replace the operating lever handle sleeve and screw the operating lever handle nut in place with a teat wrench.

With the howitzer at approximately zero elevation, replace the nut for regulating plate and block carrier hinge bearing plate. Put the block carrier in place, pass the hinge pintle of the operating lever down through the hinges until the lug which engages the rack is a sufficient distance above its normal position to clear the rack, and block the operating lever in this position. Replace the spindle spring rear seat, obturator spindle spring, and spindle spring front seat. Screw the breechblock into the block carrier in a counterclockwise direction as far as it will go. Replace the rack lock and spring, and holding the lock as far in as it will go, insert the rack in the block carrier until the reference mark on the rack is in line with the edge of the block carrier. Still holding the rack lock back in its seat, rotate the breechblock in a clockwise direction, at the same time pushing the rack into position. Lower the operating lever into position, being sure that the lug properly engages the corresponding slot in the rack. Replace the operating lever collar and detent.

Replace the firing mechanism safety plunger spring, firing mechanism safety plunger, and firing mechanism housing screw. Replace the firing mechanism housing key in the firing mechanism housing and slip the unit into the rear end of the block carrier hub. Reassemble the gas check pad, the split rings, and slip the unit on the obturator spindle. Slip the filling-in disk on the obturator spindle and place the obturator spindle in the breechblock. With the firing mechanism housing key pulled back, screw the obturator spindle into the firing mechanism housing as far as it will go, using the wrench provided for that purpose, and push the firing mechanism housing key forward into place.

Close and lock the breech carefully, being sure that everything functions properly, and replace the firing mechanism block.

#### PREPARATION OF THE LIQUID FOR THE RECOIL AND COUNTERRECOIL CYLINDERS.

The liquid for the recoil mechanism should be of the following composition:

Neutral glycerin.....	50 parts by volume.
Pure water.....	50 parts by volume.

The mixture should be boiled for 15 minutes to test 21° B. (density=1.15) at 15° C. (59° F.).

The liquid used in the counterrecoil cylinder shall be of the following composition:

Neutral glycerin.....	50 parts by volume.
Pure water.....	50 parts by volume.

Add to the mixture 4 per cent pure caustic soda (NaOH) by weight. The mixture need not be boiled.

NOTE.—The glycerin used in the two mixtures must be neutral. This may be verified by means of blue litmus paper which should not turn red. Should the

litmus paper turn red, add caustic soda (NaOH) chemically pure, and stir until the acids are neutralized, and the litmus paper no longer reddens.

The pure glycerin to be used in equal parts in the composition of the mixture is glycerin testing 25° B.

When commercial glycerin, which may test to 28° or 30° B., must be used, the amount of water to be added must be increased so that the mixture will test 21° B. (density=1.16 to 1.17).

Liquid withdrawn from the cylinders may be reused after the sediment has been allowed to settle for 24 hours. When the sediment has settled great care must be used not to disturb it when removing the liquid. The glycerin should always be strained through a clean piece of linen or muslin before using.

#### REPAIRS AND REPLACEMENTS.

The battery mechanics are authorized to replace only such parts as do not involve hot riveting, forcing, or machine work, and are forbidden to dismount any part of the recoil mechanism. The dismounting or assembling of any parts of the carriage should be done in accordance with the following instructions. Any difficulty which can not be remedied by the prescribed method should be referred to the mobile repair unit. The spare parts should be well coated with vaseline or heavy oil and each piece then wrapped in paper to prevent the oil from being rubbed off.

#### TO DISMOUNT THE FIRING MECHANISM.

With the howitzer in traveling position and the piston rod lock, Plate XIX, in firing position, remove the firing lanyard, take out the three screws which hold the lanyard bracket in place, and slip the lanyard bracket out of the firing mechanism bracket. Take out the split pin and remove the firing handle shaft nut. Pull the striker and firing handle shaft to the rear until the striker comes out of its guide. Remove the firing handle shaft piston and the handle return spring from the front end of the handle return spring housing.

Open the front cradle cover, Plate XXV, remove the stop screw from the bottom of the cradle front transom, remove the split pin which holds the lock lever pin in the lock lever, remove the lock lever pin, and slip the piston rod lock toward the left side of the carriage until the firing safety shaft is uncovered, and pull the firing safety shaft forward until it comes out of the carriage. Open the firing safety latch cover, Plate XXV, and drop the firing safety latch and firing safety latch lever out of the bottom of the firing safety latch guide.

#### TO ASSEMBLE THE FIRING MECHANISM.

With the howitzer in traveling position, move the piston rod lock to the left side of the carriage and push the firing safety shaft into its bearings until the rear end projects through the rear intermediate

bearing. Open the safety latch cover, insert the firing safety latch and the firing safety shaft lever, push the shaft through the lever, turning the shaft until the key on the shaft engages the keyway in the lever, and push the shaft home. Move the lock plate back into firing position and replace the stop screw, lock lever, lock lever pin and split pin. Insert the handle return spring inside the housing and place the firing handle safety piston in position. Slip the guide lug of the firing mechanism striker in the T slot of the bracket and move it forward until the firing handle shaft projects through the firing handle shaft piston. Replace the firing handle shaft nut and split pin, and replace the lanyard pulley bracket and lanyard. See that the firing mechanism operates properly when the howitzer is in battery and be sure that the safety latch functions properly when the piston rod lock is open before firing the howitzer.

TO DISMOUNT THE ELEVATING MECHANISM.

It is important that the howitzer should be either in traveling position with the cradle rear band bearing firmly on the cradle traveling locks, or in firing position, depressed until the cradle bears firmly on the depression stop, with the rear end of the cradle blocked up to prevent it from tipping, before dismounting any part of the elevating mechanism. If the elevating segments are to be removed, the howitzer must be in the latter position.

Remove the split pin and handwheel retainer and lift off the handwheel. Remove the two set screws which hold the handwheel latch plate and unscrew the latter. Remove the split pin, worm shaft nut and washer from the lower end of the elevating worm shaft; remove the split pin which holds the dust collar in place and lift the shaft up through the bracket. Remove the split pins and nuts from the cover bolts and remove the worm wheel case cover, Plate XXIII; lift out the elevating worm and ball thrust bearing. Remove the split pin and pinion shaft nut. Pull the elevating worm wheel from its seat on the pinion shaft. Remove the split pins and nuts from the pinion shaft bracket bolts and pull out the bracket. The pinion shaft can be then pulled out, passing it between the spokes of the right wheel.

To remove the elevating segments, remove the split pins, nuts and washers from the four transom bolts which hold the upper elevating segment transom in place and take out the transom bolts. Move the segments and transoms as a unit forward, driving them with a block of wood if necessary, until the segments drop out of the elevating segment brackets.

## TO ASSEMBLE THE ELEVATING MECHANISM.

With the howitzer in position as described above, pass the lower end of the elevating segments between the elevating segment thrust brackets, and the front transom, Plate XXIII; raise the segment unit up until the lugs on the top edge of the segments are in line with the T slots in the elevating segment brackets, the front and rear lugs straddling the front segment bracket. Pull the segment unit back into the segment bracket as far as it will go and replace the transom bolts, washers, nuts and split pins.

Pass the pinion shaft between the spokes of the right wheel and through the opening in the right trail flask, pushing the shaft home. Insert the pinion shaft bracket, pinion shaft bracket bolts, nuts and split pins. Replace the elevating worm wheel, pinion shaft nut and split pin. Place the ball thrust bearing in its seat in the elevating worm wheel case, and place the elevating worm in position, being sure that the square section of the bore is down.

Pass the elevating worm shaft down through the elevating worm shaft bracket, slip the dust collar and dust collar gasket on the shaft and lower the shaft through the worm wheel case and worm until the lower end projects below the case. Replace the split pin which holds the dust collar in place. Replace the worm shaft washer, nut and split pin. Replace the worm wheel case cover cover bolts, washers, nuts and split pins.

Replace the elevating handwheel latch plate and lock it in position with the two set screws; replace the handwheel, handwheel retainer and split pin. After the matériel is assembled, elevate and depress the howitzer through the full extent of its travel and see that the mechanism functions easily and properly.

## TO DISMOUNT THE TRAVERSING ROLLERS.

With the axle traveling lock in traveling position, remove the split pins from the Belleville spring compressors and lift off the roller box covers. Unscrew and remove the spring compressors. Remove the split pins and nuts from the traversing roller forks; lift out the fork thrust collars and Belleville springs. Lift out the forks with the traversing rollers mounted in them. Slip the traversing roller shafts out and drop the rollers out of the forks.

## TO ASSEMBLE THE TRAVERSING ROLLERS.

With the axle traveling lock in traveling position, place the traversing rollers and traversing roller shafts in the traversing roller forks and slip the assembled units in place in the traversing roller boxes. Replace the Belleville springs, four springs to each roller, arranged as follows: Bottom spring, convex side down, second spring, convex side up, third spring, convex side down, top spring,

convex side up. Replace the fork thrust collars, fork nuts and split pins. Screw in Belleville spring compressors until they seat in the traversing roller boxes. Replace the roller box covers and split pins which hold them in place.

TO DISMOUNT THE TRAVERSING MECHANISM AND AXLE.

Place the howitzer in the center of its traverse, and put the axle traveling lock in traveling position. Place a timber, chipped to fit the profilé of the trail flasks, across the underside of the trail just back of the draft hooks, Plate XXII. With a jack bearing against the timber, lift the carriage until both wheels clear the ground. Block up under the timber, remove the jack, and remove both wheels.

Remove the split pins and handwheel retainers and lift off the handwheels. Remove the split pins and handwheel shaft nuts, and pull the shafts out. Open the gear case cover and remove the handwheel shaft pinions. Remove the split pins and intermediate shaft nuts and lift out the traversing intermediate gears. Take out the gear case dowels and remove the split pins and nuts from the gear case bolts. Remove bolts and take off gear cases. Remove the split pins which hold the dust covers in place; unscrew the traversing intermediate shaft bearings and lift out the shafts. Remove the split pin from the thrust bearing adjusters, and remove the thrust bearing adjuster locks. Remove the gasket rings and leather gaskets from the ends of the axle housing. Plate XXI; remove the housing cover screws and lift off the traversing screw housing covers. Unscrew the traversing screw bearings. Pull off the traversing gears. If it is desired to remove the axle, place the axle traveling lock in firing position and pull the axle, traversing nut support, traversing nut, and traversing screw as a unit, out of either side of the carriage. It is preferable to remove this unit from the left side of the carriage to prevent damage to the azimuth scale. Drive out the traversing nut taper pin and remove the traversing nut and screw from the traversing nut support. Drive out the rivet which holds the traversing screw stop collar in place and remove the stop collar. Screw the traversing nut off the traversing screw. The traversing nut support can not be removed from the axle in the field.

The traversing screw can be removed with the axle in place in the following manner: With the axle traveling lock in traveling position, after the traversing screw bearings and traversing gears have been removed, turn the screw until its right end projects beyond the end of the traversing screw housing. Drive out the rivet which holds the traversing screw stop collar in place and remove the stop collar. Then turn the screw in the opposite direction until it comes out of the traversing nut, and remove the screw from the left side of the housing.

## TO ASSEMBLE THE AXLE AND TRAVERSING MECHANISM.

The carriage should be blocked up as described above.

If the axle has been removed, screw the traversing nut on the traversing screw, screw on the traversing screw stop collar\* and pin it in place, riveting the ends of the pin cold. Center the traversing nut between the shoulder on the left-end of the screw and the stop collar. Place the traversing nut in the traversing nut support. Replace the traversing nut taper pin and drive it home. When the above parts are thus assembled, be sure that the traversing screw stop collar is on the opposite end from the azimuth scale on the axle and that the portion of the traversing nut which is cut away to form a grease cup and the azimuth scale on the axle are both on the upper side of the assembled unit. Slide the unit into the axle and traversing screw housings from the left side of the carriage, that end entering first which carries the traversing screw stop collar. Center the axle longitudinally in the axle housing and put the axle traveling lock in traveling position and reassemble the traversing rollers.

If the axle has not previously been removed, with the axle traveling lock in traveling position, enter the screw into the left side of the housing and start the thread in the traversing nut. Turn in a clockwise direction until the right end of the screw projects beyond the housing. Replace the traversing screw stop collar and pin, riveting the ends of the latter cold. Turn the screw in a counterclockwise direction until the nut is centered between the shoulder on the left end of the screw and the stop collar.

Replace the two traversing gears. Pass the intermediate shafts through the dust covers, dust cover gaskets, intermediate shaft bearings, and into the traversing gear boxes. Replace the filler plates and gear boxes on the trail, allowing the lower ends of the shafts to drop through the holes in the traversing screw housing, the pinions meshing with the traversing gears. Replace the gear case dowels and all gear case bolts, pulling the nuts up tight and replacing the split pins. See that the pinions on the lower ends of the intermediate shafts mesh properly and uniformly with both of the traversing gears. Screw the intermediate shaft bearings in place and replace the split pins over the dust collars. Back out the thrust bearing adjusters slightly and screw the traversing screw bearings into position. Replace the traversing screw housing covers and housing cover screws. Replace the leather gaskets and gasket rings on the ends of the axle housing. Tighten up the thrust bearing adjusters until they just bear on the ends of the traversing screw and replace the thrust bearing adjuster locks and split pins. Replace the traversing intermediate gears; after placing the handwheel shaft pinions in position, pass the handwheel shafts through the gear boxes and pinions, and replace

the shaft nuts and split pins. Replace the handwheels, handwheel retainers, and split pins. Close the gear case covers and place the axle traveling lock at firing position. Traverse the gun to the full extent of the traverse in both directions, and see that the lost motion is reduced to the minimum. If the lost motion is excessive, remove the adjuster locks, tighten up the adjusters, and replace the adjuster locks and split pins. The thrust bearing adjusters should be so adjusted that any motion of the handwheels will, without binding, cause a corresponding movement of the carriage across the axle.

**TO DISMOUNT THE AXLE TRAVELING LOCK.**

Remove the split pin which bears against the axle traveling lock bushing and unscrew the bushing. Remove the split pins and nuts from the bolts which hold the axle traveling lock bearing in place. Remove the lever shaft bushing and bearing as a unit. To disassemble the shaft remove the split pin and lock shaft nut, and slip the axle traveling lock lever bearing and bushing off the small end of the shaft. Unscrew the lock box cover and remove the spring and axle traveling lock. To remove the axle traveling lock box take out the split pins and remove the nuts from the two bolts which hold the latter in place and lift off the box.

**TO ASSEMBLE THE AXLE TRAVELING LOCK.**

Place the axle traveling lock box in position with the side opening toward the left trail flask and replace the nuts and split pins to the bolts which hold it in place. Place the axle traveling lock, Plate XXIV, in the box with the edge, which is cut away, on the underside. Traverse the carriage, if necessary, until the teeth on the axle traveling lock mesh with the grooves cut in the axle. Slip the small end of the shaft through the axle traveling lock bushing and bearing, and pass the cam end of the shaft through the opening in the trail and the lock box, being sure that the point of the cam is toward the front of the carriage. Replace the bolts, nuts, and split pin which hold the bearing in position and replace the axle traveling lock lever in such a manner that the outer end will lie between the two axle traveling lock lever stops when the point of the cam is toward the front of the carriage. Replace the axle traveling lock spring and screw the lock box cover on tight. Back off the lock box cover until the notch on the under edge of the rim is in line with the bushing opening in the side of the lock box. Screw in the axle traveling lock bushing and replace the split pin.

Operate the axle traveling lock to see that it locks the carriage in the center of its traverse when the handle is in traveling position and does not engage when the handle is in firing position.

**TO DISMOUNT THE SPADE.**

With the spade in traveling position and the trail blocked up so that the spade clears the ground in all positions, drive out the pin which holds the spade shaft nut in place and unscrew the nut. Pull the spade shaft out to the left side of the carriage driving it, if necessary, with a copper hammer or sledge, using a block of wood to receive the blows.

To remove the spade latch shaft drive the pin out of the right spade latch shaft nut, unscrew the nut, and remove the right spade latch. Drive the pin which holds the shaft in place out of the right bearing of the fixed spade. Turn the spade latch handle to vertical position and pull the shaft out to the left, driving it as above if necessary. Drive the pin out of the left spade latch shaft nut, unscrew the nut, and remove the left spade latch.

**TO ASSEMBLE THE SPADE.**

With the trail blocked up as described above put the left spade latch on the left end of the spade latch shaft, the handle pointing in a direction almost perpendicular to the flat surfaces on the ends of the shaft. Replace the left spade latch shaft nut and drive the pin in place. Reaching through the opening in the under side of the fixed spade, press the spade latch spring up and slip the spade latch shaft into its bearings, entering it from the left side and keeping the latch handle vertical. Release the spring and turn the handle forward and down until the spring engages the flattened spaces in the center of the shaft. Replace the right spade latch and nut and drive the pin in place. Drive the pin which holds the spade latch shaft in place into the right bearing of the fixed spade.

Put the spade in place and slip the spade shaft into position from the left side, turning it until the dowel engages the notch in the left spade brace. Replace the spade shaft nut and drive the pin into place.

**TO DISMANTLE THE BRAKE RIGGING.**

Remove the split pins, shaft arm nuts, and brake shoe stops. Slip the brake heads with the brake shoes riveted to them off the ends of the brake shaft arms. Remove the split pins and drive the brake shaft keys out through the holes in the shield provided for that purpose. Pull out the brake shaft arms, using a bar as a pry through brake shaft keyholes if necessary.

Remove the split pin, nut, and washer from the lower end of the brake screw. Pull the screw out of the brake screw supporting bushing and take the bushing out of the brake screw bracket. Take out the split pin and screw off the brake screw supporting nut. Turn the brake screw in a clockwise direction until it comes completely

out of the brake screw nut, pulling the screw through the hole in the shield. Remove the split pins and nuts from the bolts which hold the brake screw bracket in place and remove the bracket.

Remove the brake shaft lever and brake shaft bushing and pull the brake shaft out of its bearings. It may be necessary to traverse the howitzer to the end of its travel in order to clear the wheel. The brake screw nut can not be removed from the lever in the field.

To disassemble the brake screw, remove the split pin and take off the brake handle. Remove the split pin and screw the brake screw stop off the brake screw.

#### TO ASSEMBLE THE BRAKE RIGGING.

With the howitzer traversed to the end of its travel if necessary to clear the wheel, place the brake shaft in its bearings, large end of the keyholes toward the shield. Replace the brake shaft lever and bushing. Place the brake arms in the ends of the shaft, curved portion up, replace the brake shaft keys, passing them through the holes in the shield, and replace the split pins.

Replace the brake screw bracket, bolts, nuts, and split pins. Put the brake handle on the screw and replace split pin. Replace the brake screw stop and split pin. Pass the screw through the hole in the shield and screw it into the brake screw nut until it projects several inches beyond the nut. Replace the brake screw supporting nut and split pin. Slip the brake screw bushing into the bracket and pass the end of the screw through it. Replace the brake screw washer, nut, and split pin.

Replace the brake heads with shoes riveted to them and replace the brake shoe stops, nuts, and split pins.

#### TO REMOVE THE BRAKE BAND FROM THE CAISSON.

With the brake released, remove the split pin and pin which anchors the brake band to the brake hanger and remove the split pin and pin which fasten the band to the brake rod lever. Remove the split pin which holds the band clip in place and remove the clip. Lift the band up, springing the ends over the drum. Plate XXXIV.

#### TO REPLACE THE BRAKE BAND.

Spread the ends of the brake band and pass them down over the drum. Replace the pins which anchor the ends of the band to the brake hanger and brake rod lever and replace the split pins. Replace the band clip, being sure that the lug of the band guide enters the slot in the clip, and replace the split pin which holds the clip in place.

After replacing the brake bands the tension in the brakes should be tested before using the vehicle. To adjust the tension in the brakes, remove the split pin and pin which attaches the upper end of the

brake lever rod to the brake lever bearing. Adjust the length of the brake lever rod by screwing the brake rod end on or off the rod as desired and replace the pin and split pin. Should the tension on the brake bands be unequal, remove the pin which connects one of the brake rods to the brake rod lever and adjust the brake rod end as above. Replace the pin and split pin.

**TO REMOVE THE SUPPORTING SPRINGS FROM THE CAISSON.**

Remove the wheel as directed above on the side from which the springs are to be removed. Remove the split pins, spring bolt head locks, spring bolt heads and washers, and lift off the carrying spring. Remove the split pins and nuts from the lower ends of the spring bolts and lift out the spring bolts. Raise up the end of the axle and slip out the Belleville spring, as shown on Plate XXXIV.

**TO REPLACE THE SUPPORTING SPRING.**

With the caisson jacked up as above, lift up the end of the axle and place the Belleville springs under the axle bracket arranged in four sets of four each, the bottom spring of each set concave side up; second spring, concave side down; third spring, concave side up; top spring, concave side down. Replace the spring bolts, passing them through the axle bracket, Belleville spring, and the lower flange of the guide brackets. Replace the nuts and split pins to the lower ends of the spring bolts. Replace the carrying springs, washers, spring bolt heads, spring bolt head locks, and split pins. Replace the wheel as above.

**TO REMOVE AXLE BRACKET FROM THE CAISSON.**

Remove the carrying springs and spring bolts as directed above, remove the split pins and nuts from the guide bolts, and lift out the guide bolts. Remove the brake band and take out the pin which connects the brake rod lever to the brake hanger. Remove the split pins and nuts from the axle bracket screws, allowing the brake hanger bracket to drop off. Remove the axle bracket screws and slide the axle bracket off the end of the axle.

**TO REPLACE THE AXLE BRACKET.**

With the caisson jacked up as above, slide the axle bracket over the end of the axle into position, being sure that the hole to receive the band clip is on top. Replace the brake hanger bracket, axle bracket screws, and nuts. Tighten the nuts until the bracket clamps the axle and replace the split pins. Replace the guide bolts, nuts, and split pins. Reassemble the supporting springs and brake band and replace the wheel as directed above.

**VERIFICATION AND ADJUSTMENT OF THE SIGHTS.**

Battery mechanics are forbidden to disassemble any parts of the quadrant or panoramic sights and are allowed to make only such adjustments as are hereinafter prescribed. Adjustments are only to be made with tools provided by the Ordnance Department for that purpose and in the presence of a commissioned officer. Any difficulties which can not be corrected by the methods herein prescribed should be referred to the mobile repair unit.

When out of adjustment the sights will cause inaccurate firing and they should therefore be frequently verified and adjusted when necessary. The sight-adjusting target, Plate XLVII, is provided for verifying the sights in arsenals, ordnance depots, or when a suitable foundation for the carriage is available. Verification of the sights is of such importance that battery commanders may find it advantageous to make permanent arrangements for such verification when occupying a position for an extended period.

The procedure under the above conditions is as follows: Place the carriage on a level concrete or wooden platform and with the aid of the testing level see that the center line of the trunnions parallel to the axle of the carriage is horizontal. Level the sight transversely, set the angle of site pointer at 300 mils, set the elevating scale at 0° elevation, and with the aid of the testing level elevate or depress the howitzer until the center line of bore is horizontal. The bubble in the elevation level should be centered between the reference marks on the level vial. If the bubble is not centered, operate the angle of site worm until the vial is level. Loosen the set screw which holds the rear micrometer clamp in place and unscrew the clamp. Turn the rear micrometer drum without turning the worm until the index on the angle of site housing points to zero. Tighten the rear micrometer clamp and set screw. (See Pl. XXVIII.)

Suspend the target (Pl. XLVII) in a plane perpendicular to, the bore of the howitzer and at a distance of about 100 meters. Place the front and rear bore sights in the howitzer and move the target until the center line of the bore as determined by the bore sights pierces the target at the point marked "Bore." The verticality of the target should be then verified by a plumb line attached at the point A, which should coincide with the line A-B. With the panoramic sight mounted in the shank of the quadrant sight set the azimuth scale and elevation micrometer of the panoramic sight at zero. With the sights thus arranged, the line of sight should pass through the point on the target marked "Panoramic sight."

If the line of sight pierces the target above or below the point marked "Panoramic sight," it indicates that the elevation micrometer (66) of the panoramic sight is out of adjustment. Operate

the elevation micrometer (66) until the line of sight pierces the target on the horizontal center line of the point marked "Panoramic sight." Loosen the micrometer locking screw (72) and turn the elevation micrometer (66) without turning the elevation worm (18), until the index on the rotating head (60) points to zero. Tighten the micrometer locking screw (72). (See Pl. XXIX.)

If the line of sight pierces the target to either right or left of the point marked "Panoramic sight," it indicates that either the cross level of the quadrant or the azimuth micrometer index of the panoramic sight or both are out of adjustment. Traverse the panoramic sight until the line of sight pierces the target at the proper point and elevate the howitzer to maximum elevation, at the same time elevating the quadrant sight. If the point where the line of sight pierces the target appears to move either to right or left, it indicates that the cross level of the quadrant sight is out of adjustment. Cross level the quadrant sight by turning the leveling-worm handwheel (Pl. XXVIII) until the howitzer can be elevated and depressed to the full extent of its travel without moving the point where the line of sight pierces the target to either right or left. With the wrench provided for that purpose, loosen the cross level set screw and carefully move the cross level holder until the bubble in the level vial is centered between the reference marks, and tighten the set screw.

If the azimuth micrometer index (53) (Pl. XXIX) does not read zero with the howitzer returned to 0 elevation it indicates that the azimuth micrometer index (53) is also out of adjustment. Loosen the micrometer locking screw (75) and with the test wrench provided for that purpose, turn to micrometer index (53) until the arrow points to 0 on the azimuth micrometer scale (52), at the same time holding the latter to prevent it from turning. Tighten the micrometer locking screw (75).

#### ADDITIONAL TESTS.

After the sights are adjusted they should be submitted to the following tests to assure their accuracy at extremes of elevation and azimuth:

(a) With the carriage level and howitzer and sights at zero elevation and deflection, see that the line of sight and axis of bore prolonged the target (Pl. XXXIX) at the proper points.

(b) Elevate the howitzer to its maximum elevation without altering the elevation of the sight. As the elevation of the howitzer is altered, the line of sight should follow the vertical line through the point marked "Panoramic sight" on the target, Plate XLVII.

(c) With conditions as in (a) traverse the howitzer to its extreme positions in azimuth; as the deflection is altered the line of sight should follow the horizontal line through the point marked "Panoramic sight."

By construction and assemblage the sights, if properly adjusted, should fill the above conditions with substantial accuracy. If error be noted, a report of the facts of the case with the cause, if known, should be made to the Ordnance officer charged with the repair of the matériel for his information and action.

#### VERIFICATION AND ADJUSTMENT OF THE SIGHTS IN THE FIELD.

In the field or when a suitable foundation for the carriage is not available, the sights may be verified and adjusted in the following manner, neglecting the angle of parallax. Jack up one wheel of the carriage until the center line of the trunnions parallel to the axle of the carriage is horizontal, as determined with the aid of the testing level. Elevate or depress the howitzer until the center line of the bore is horizontal as determined with the aid of the testing level, and set the elevation scale of the quadrant sight at zero. Cross level the quadrant sight, verify and adjust the elevation level, Plate XXVIII, as directed above. With the aid of bore sights train the howitzer on some distant aiming point (2,000 or 3,000 meter range). Proceed as above to adjust the panoramic and quadrant sight so that the line of sight and the center line of the bore will intersect at the aiming point.

#### VERIFICATION AND ADJUSTMENT OF THE PEEP SIGHT.

The procedure for verifying the peep sight is similar to that of the panoramic sight.

To adjust the peep sight in a vertical direction, remove the split pins which hold the cross wire holder and holder sleeve in place. Screw the holder sleeve up or down until the line of sight pierces the target at the proper point, at the same time holding the cross wire stationary and replace the split pins.

To adjust the peep sight in a horizontal direction, turn the peep sight screw until the line of sight pierces the target at the proper point. Loosen the screws which hold the deflection scale in place and shift the scale until the index on the peep sight points to zero, and tighten the screws. Loosen the handle-locking screw and turn the peep-sight screw handle without turning the peep-sight screw until the micrometer scale on the handle reads zero, and tighten the locking screw.

#### INSPECTION BY THE BATTERY MECHANICS.

At intervals of from two weeks to one month, and oftener if the amount of firing warrants, the matériel should be thoroughly inspected by the battery mechanics under the direction of the chief mechanic. The inspection should consist of a thorough examination

of the howitzer and carriage and all vehicles in the battery equipment. The instructions given for daily inspection by the gun crew should be carried out and in addition thereto the following directions should be followed.

Examine the bore with extreme care to see that serious erosion has not set in. If there are any signs of erosion the fact should be reported to a commissioned officer.

Operate all moving parts and see that they work freely and properly.

Examine the piston-rod locking mechanism carefully to see that the parts are well greased and not rusted. See that the pins which hold the piston-rod nuts in place are in place and tight.

Examine the cylinder heads and stuffing boxes to discover evidence of leakage. If the cylinder heads or stuffing boxes are found to be in a leaky condition the mobile repair unit should be called upon to examine and replace the gaskets if necessary.

Drain a small quantity of liquid from the recoil cylinder and refill it to the proper level.

Open the gage-cock valve and allow a small quantity of gas to escape, replacing it with the air pump. See that the air pump is in good condition and operates without difficulty against the service pressure.

Allow a small quantity of liquid to escape from the counterrecoil cylinder and replace it with the liquid pump. See that the liquid pump operates satisfactorily against service pressure.

Examine the sights to see that the moving parts operate freely and without excessive backlash.

Examine all crown nuts to see that they are tight and that split pins are in place.

Examine the trail and cradle to locate loose rivets.

Examine the painted portions of all vehicles to see that the paint has not been removed in any way.

Direction for inspection and care of motor vehicles and the reel and cart are given in the handbooks of the respective vehicles.

A report of the inspection covering all irregularities or evidence of neglect on the part of the gun crew should be made to the battery commander.

#### **GENERAL NOTES ON CARING FOR THE MATÉRIEL.**

The more time artillery matériel spends in the repair shop the less time it is available for firing at the enemy. The battery personnel should keep their matériel out of the shops by giving it the daily care prescribed in the regulations. This is the minimum.

Don't neglect limbers and caissons. Bearing surfaces and the sleigh slides must be maintained clean and free from burrs, scratches,

etc. Elevating and traversing gears must be operated to the extent of their runs and oiled daily. See that screws and nuts are tight.

Rust is the starting point of serious injury. All bearings, and other surfaces in contact, elevating racks, screws, etc., must be kept clean and oiled. In case mud or other dirt gets on them, do not wait, but clean them at once. Wheel axles should be periodically examined. Always before and during a journey they should be greased.

Cleaning and lubricating matériel furnished by the Ordnance Department only will be used. Don't let water get into the oil and grease. Not only all the numbered oil holes must be oiled, but all other bearings as well. Care should be taken to remove kerosene before lubricating, as the presence of kerosene under lubricating oil will cause rusting.

As soon as wear becomes apparent on any part, see that a spare is available. Replace it in due time, and return the worn parts to the mobile ordnance repair shop.

**RECOIL MECHANISM.**—The normal quantity of liquid, and gas pressure, must always be maintained. Inspection of the alignment of the sight should be made daily, or oftener, in case of suspicion.

Replacement of such parts as are supplied to the batteries may be made by the battery personnel. However, if filing, forging, riveting, etc., are necessary, send the gun to the mobile ordnance repair shop.

**CARE OF GUN BORES.**—The wear of gun tubes does not depend entirely upon the number of rounds fired, but very much upon the way in which the tubes are cleaned, cooled, and cared for, and upon the greasing of the rotating bands.

Copper fouling is a continual source of trouble, and constant effort will be necessary to prevent its accumulation. The ideal manner of using a gun is to wash and grease the bore before each shot, and to clean each shell before firing, and to grease its rotating band, leaving a little on the forward edge. This will not always be possible, but the ideal should be always kept in sight. Howitzers never become copper-fouled if properly cared for. A pail of water must be kept at each gun and at each interval in firing wash and grease lightly the bore. Too much grease will cause smoke. Once a day the breechblock should be dismounted and cleaned and oiled. It is also of great importance, whenever the rate of fire permits, that the cannoneer looks through the breech before each loading to be sure that no bits of cartridge case or wadding or unburned powder remain in the bore. The presence of such foreign matters causes imprints in the walls of the gun, and sometimes prematures. During night firing, use the sponge.

To examine the bore, hold a sheet of white paper at opposite end, so as to reflect light into it. Inspect it from both ends. To examine a particular spot, introduce a short candle at the end of a flat stick.

The life of a gun usually depends upon the erosions and wear at the forcing cone, or beginning of the rifling.

Erosions are slits made by the hot gases. They appear as wide streaks with smooth edges, and are usually near the forcing cone. They are more likely to be produced by the heavier charges and a fast rate of fire, therefore use as far as possible the lower charges, and let the howitzer cool off between rounds.

The breech should not be opened for at least one minute after a misfire. All work on recoil mechanisms, sights, and other optical equipment should be done in presence of a commissioned officer.

Brake handwheels must not be struck or kicked. Do not strike any metal part directly with a hammer; interpose a piece of wood, copper, etc.

Do not unnecessarily expose ammunition to the sun or heat, nor load into a warm gun before time for firing. If this is done, erratic shooting may result. When not firing, see that the firing hammer is locked. When traveling, lock the carriage to axle and the sleigh to the cradle.

The decomposition of powder may be detected by the warping of the sides of metal powder boxes, and by the odor when the box is opened. Ammunition is also very sensitive to dampness. Remnants of powder composed of fractions of charges, which have been removed to make lower charges, must never be used in the battery, but must be sent back to the rear.

Never load guns in advance. Slight bulges do not put a gun out of service, but when pronounced, the ordnance inspector of artillery must be advised. When shells, etc., burst near the gun, make sure that the tube has not been struck before firing.

If serious erosions occur in the vent, change the mushroom head. Don't try to turn the cross leveling screw without having loosened the sight-support locking handle. This remark applies to all similar devices with locking screws, etc.

When not in use keep the muzzle and breech covers on the howitzer. Keep the spare parts coated with heavy grease and wrapped in paper. Don't attempt to ram a shell out of the bore, unless it comes out easily by gentle raps; send it to the mobile repair shop.

## GENERAL INFORMATION.

### PAINTING ARTILLERY MATÉRIEL.

Ready-mixed paint for this purpose is issued in 2½-gallon cans, and is applied to both wood and metal parts. The paint of the following colors is for camouflage: Black, cream, green, and yellow. The olive-

drab is for the nonvisible surfaces. Special quick-drying olive-drab paint is also used for surfaces where time does not permit of drying the ordinary paint. If the paint is too thick, turpentine should be used as a thinner, but not to greater extent than 2 per cent by volume.

All steel and iron nonbearing surfaces will be painted. Wearing and bearing surfaces, such as teeth of gear wheels, slides, and piston rods, will not be painted. In general, repainting should only be on surfaces previously painted at place of manufacture.

All parts to be painted should be free from dirt or grease. They may be washed in a liquid made by dissolving one-half pound sal soda in 8 quarts of warm water, then rinsed in clean water and wiped thoroughly dry.

Where the matériel is in fair condition and only marred in spots, the marred places should be primed with olive-drab paint and permitted to dry. Then the whole surface should be sandpapered with No. 1½ sandpaper and a coat of paint of original color applied and allowed to dry thoroughly before use.

In general, two coats of paint per year will be sufficient to keep the matériel in good condition. After repeated painting the paint may become so thick as to scale off in places or give an unsightly appearance. It may then be removed for repainting, as follows:

Dissolve 1 pound of concentrated lye, powdered form, in 6 pints of hot water, and slake in enough lime to give the solution the consistency of paint. Use the solution freshly mixed and apply to the parts where paint is to be removed with a brush or with waste tied to the end of a stick. When the solution begins to dry on the surface use a scraper to remove the old paint, and complete the cleaning of the surface with cloth and water. If one application is not sufficient to loosen the paint, apply a second coat. Before painting, wash the surface with sal soda water, rinse with clean water, and then wipe thoroughly, as described above.

#### INSTRUCTIONS FOR RIVETING.

Whenever a rivet is broken, loose, or needs replacing for any reason, the rivets should be heated to a light yellow (just below white), color. They may be heated in the forges furnished with the battery equipment or in a permanent blacksmith's forge. While heating, keep the rivets covered with coals in order to prevent scaling. Rivets one-fourth inch and less in diameter may be driven cold when it is impracticable to heat them. Drive them hot, however, when practicable. Drive all rivets greater than one-fourth inch in diameter hot in all cases. Do not overheat or burn the rivets. Remove all scale from rivets after heating and before driving. Drive the rivets home with a hammer before attempting to form the head.

Hold rivets solidly in place with a sledge, crowbar, and fulcrum, railroad iron, or similar heavy piece of steel. Partially form the head with the face and peen end of a hammer. When the head is practically formed by this operation use a rivet set for final forming of the head. The rivet set is only for this final operation. Loose rivets will result if they are not peened down with a hammer before the rivet set is used. The rivets must be held solidly in place while the riveting is being done, otherwise loose rivets result.

The pneumatic hammer on the artillery repair truck may be used for driving the smaller rivets.

Before starting to heat the rivets the pieces to be riveted should be carefully fitted and bolted together. If the holes in the two pieces are not in perfect alignment the cause should be determined and rectified instead of attempting to drift the pieces into alignment. If necessary for perfect alignment, a slight amount of reaming or filing will be permitted. In no case should a rivet hole be reamed larger than about one thirty-second inch in excess of the diameter of the rivet. On account of inaccessibility it is sometimes difficult to insert a rivet. In such cases it may be inserted with a twisted stiff wire or with a small wooden stick split at the end to hold the rivet. Arrangements must be made beforehand to back up or hold the rivet in place the instant it is located in order that it may not have cooled too much for proper riveting. Hot riveting is preferable to cold riveting, as the head is more easily formed when hot and the contraction of the rivet in cooling gives a tighter fit.

#### CLEANING AND DISINFECTING OF MATÉRIEL AFFECTED BY GAS.

##### PHOSGENE, CHLORINE, ETC.—PROTECTION.

Matériel which are in constant danger of gas attacks, whether from gas clouds or gas shells, care should be taken to keep all bright parts of their guns or howitzers, carriages, mountings, and accessories well coated with oil.

Sights and all instruments should also be smeared with oil and protected with covers when not in actual use, care being taken that the oil does not come in contact with any glass or find its way into the interior of the instrument.

Cartridge cases of ammunition stored with the battery and all uncapped fuzes, or fuzes which have been removed from their cylinders, should be wiped over with oil as soon as possible and protected with a cover.

##### CLEANING.

All bright parts of guns and trench mortars, together with all accessories and spare parts exposed to the gas, must be cleaned and wiped dry as soon as possible after the attack, and in any case within 24 hours, after which they should be thoroughly coated afresh with oil.

The same applies to the whole of the ammunition still in the battery position. Ammunition which for any reason had not been oiled must be cleaned and oiled. It is desirable to expend it as soon as possible.

DISINFECTION OF MATÉRIEL OF ALL KINDS AFFECTED BY MUSTARD GAS.

The following measures should be used for the removal of mustard gas from various materials and equipment (guns, projectiles, cases, wood, metals, rope, etc.) which have come in contact with mustard gas. For all of the operations indicated below the respirator and special gloves must be worn.

(1) Commence by freeing the objects from dirt, lumps of earth, and liquid with wooden spatulas, rags, etc., which will be buried immediately after this operation; they must never be burned.

(2) Sprinkle a continuous layer of dry chloride of lime over the parts of the equipment that lend themselves to this treatment. After two hours wash off the layer of chloride of lime and rinse thoroughly. It is imperative that all the chloride of lime be removed in order to prevent the deterioration resulting from the prolonged action of the chloride of lime. In the case of ammunition it is imperative to prevent particles of chloride of lime from being introduced into the bore of the piece.

(3) Whitewash soiled parts, which do not lend themselves to sprinkling with dry powder, with a thick paste of chloride of lime made from 3 volumes of chloride of lime and 1 volume of water. After two hours wash off the chloride of lime.

(4) The delicate parts of apparatus, such as breech mechanism, sighting apparatus, glasses, etc., which would be injured by chloride of lime, should be cleaned by dry polishing with rags. After this operation the rags should be buried.

(5) If one has large quantities of water at his disposal, he may, in the place of chloride of lime, use water. The water should be warm, but never boiling, and large quantities should be used. This can not be done in the case of greasy articles, where only chloride of lime can be used.

(6) When it is not necessary to immediately use contaminated matériel, or when one has not the above means at his disposal, it may be considered that the handling of the matériel and apparatus is not dangerous after six or eight days.

PROTECTION AGAINST MUSTARD GAS.

It must not be forgotten that practically all fabrics and materials, such as wool and cotton, rubber, and oilcloth, can be penetrated by mustard gas if sufficient time be given. The mustard gas actually dissolves in these materials and penetrates them by a slow process of diffusion. In general, it may be said that the greater the length of

time required for penetration the greater the danger in wearing these articles after they have been exposed for some time to mustard gas. Attention is called to the fact that rubber boots which have been worn in an area shelled heavily with mustard gas may be a grave danger to the men who wear them several days after the bombardment. Fabrics thoroughly impregnated with boiled linseed oil will resist penetration by mustard gas for over an hour, but it must not be forgotten that after this time these articles are dangerous because of the mustard gas that they contain dissolved in the linseed oil and that they must be destroyed or the oil renewed.

**TRANSPORTATION OF ARTILLERY MATÉRIEL AFFECTED BY MUSTARD GAS.**

(a) The removal will be effected by automobile units whenever possible; if horse transport must be used, the route will be carefully reconnoitered in order to avoid infected ground.

(b) The matériel will be disinfected as thoroughly as possible before its removal.

**REPAIRS FOR FIELD ARTILLERY MATÉRIEL.**

Instructions relative to making repairs to field batteries and furnishing ordnance stores and supplies for them will be found in the general orders issued by the War Department from time to time.

Instructions in reference to the care, use, and repair of delicate instruments, such as sights, telescopes, and range finders, will be found in General Orders, No. 47, War Department, Washington, March 24, 1905, and in O. O. Pamphlet No. 1795.

## PART III—EQUIPMENT.

### LIST OF EQUIPMENT PERTAINING TO REGIMENTS OF 155-MM. HOWITZER MATÉRIEL MODEL OF 1918 (SCHNEIDER) MOTORIZED, ON WAR FOOTING.

The following table sets forth the total equipment of one motorized regiment of 155-mm. howitzers, model of 1918 (Schneider), on war footing. Under heading "Where carried" shows, in general, where each article is intended to be carried, but the commanding officer or battery commander may use his discretion as to the disposition of any articles for which no particular fitting or receptacle is provided.

The following abbreviations are used to indicate the vehicle or chest in which items are carried:

A. T.	On ammunition truck.
A. R. T.	On artillery repair truck.
A. S. T.	On artillery supply truck.
B. & R. C.	In bolt and rivet chest.
B. C.	In bench chest.
B. S. B.	In bar stock box.
C.	On caisson.
Cart.	On cart.
C. C.	In carpenter's chest.
Chassis.	On 2-ton Nash truck chassis.
C. L.	On carriage limber.
C. M. C.	In cleaning materials and small stores chest.
C. W.	On caisson wheels.
F. C.	In fluid chest.
Fg. C.	In forge chest.
G. C.	In grindstone chest.
H.	On howitzer.
H. C.	On howitzer carriage.
L. R. T.	On light repair truck.
M. T. B.	In motor vehicle tool box.
O. B.	In oil box.
O. R. C.	In optical repair chest.
P. C.	In pump chest.
R. C.	In reconnaissance car.
Reel.	On reel.
S. O. C.	In staff observation car.
S. T. K.	In saddler's tool kit.
T. B.	In trail box.
Tel. T.	On telephone truck.
T. K.	In tool kit.
T. T.	On tank truck.
2½-T. T.	On 2½-ton artillery tractor.
5-T. T.	On 5-ton tractor.
W. S. C.	In welding supply case.
W. T.	On wireless truck.
W. T. C.	In welding tool case.

**UNITS COMPOSING A REGIMENT OF 155-MM. HOWITZER MATÉRIEL, MODEL OF 1918  
(SCHNEIDER) MOTORIZED, ON WAR FOOTING.**

Unit.	Bat-tery.	Head-quarters com-pany.	Sup-ply com-pany.	Regi-ment.	Property classi-fication.	
					Class.	Divi-sion.
155-mm. howitzer.....	4			24	IV	3
155-mm. howitzer carriage.....	4			24		
155-mm. howitzer carriage limber.....	4			24		
155-mm. howitzer caisson.....	12			72	IV	9
Car, staff observation.....	1	4		10		
Car, reconnaissance.....	1			6		
Car, headquarters instrument.....		4		4	IV	10
6-horse reel and cart.....	1			6		
Tractor, artillery, 2½-ton <sup>1</sup> .....	1	4		10		
Tractor, artillery, 5-ton <sup>2</sup> .....	10			60	IV	1
Trailer, machine gun, antiaircraft <sup>3</sup> .....	1			6		
Truck, ammunition <sup>4</sup> .....	14	9		95	IV	9
Truck, artillery repair.....			3	3		
Truck, artillery supply.....	1	1	6	13		
Truck, light repair.....			1	1	IV	9
Truck, tank.....			3	3		
Truck, telephone.....		1		1		
Truck, wireless.....		1		1	IV	9
Ambulance (Medical Department).....				3		
Car, 5-passenger (Q. M. C.).....	1	5	1	13		
Kitchen, rolling (Q. M. C.).....				8	IV	9
Truck, cargo (Q. M. C.).....				16		
Motorcycle, with side car (Q. M. C.).....	12	24	10	110		

<sup>1</sup> Used to haul 6-horse reel and cart.

<sup>2</sup> Used to haul carriage limbered and caissons.

<sup>3</sup> Used to carry antiaircraft machine guns.

<sup>4</sup> Used for transportation of passengers, fuel, oil, water, ammunition, baggage, and ration.

**EQUIPMENT FOR UNITS COMPOSING A REGIMENT OF 155-MM. HOWITZER MATÉRIEL,  
MODEL OF 1918 (SCHNEIDER) MOTORIZED, ON WAR FOOTING.**

Number per organiza-tion.				Article.	Where carried.	Property classi-fication.	
B.	H. C.	S. C.	R.			Class.	Divi-sion.
				<b>Tools and accessories for howitzer and howitzer carriage.</b>		IV	3
6			36	Adjustable "S" wrenches.....	4-T. B. 2-P. 6		
1			6	Air pump.....	P. C.		
1			6	Assembling sleeve for air pump.....	P. C.		
4			24	Cleaning brushes.....	T. B.		
4			24	Cleaning tools.....	T. B.		
4			24	Copper hammers.....	T. B.		
4			24	Covers (breach).....	H.		
4			24	Covers (cradle).....	H. C.		
4			24	Covers (muzzle).....	H.		
4			24	Covers (sight).....	H. C.		
4			24	Covers (sponge).....	H. C.		
8			48	Drag ropes.....	H. C.		
4			24	Drag rope pouches.....	H. C.		
4			24	Drills for primer seat.....	T. B.		
4			24	Extractors for firing mechanism housing key.....	T. B.		
4			24	Files, curved smooth (for breach threads).....	T. B.		
2			12	Filling pipes for pumps.....	P. C.		
2			12	Filling pipes for reservoir.....	P. C.		
4			24	Funnels.....	T. B.		
4			24	Funnel pipes.....	T. B.		
4			24	Grease brushes.....	T. B.		
4			24	Grease guns.....	T. B.		
4			24	Gunners quadrant cases.....	T. B.		
8			48	Hand fuze setters, U. S. model 1913.....	T. B.		
8			48	Hand fuze setters (French).....	T. B.		
4			24	Horizontal oilers.....	T. B.		
4			24	Knives.....	T. B.		
4			24	Lanyards.....	H. C.		
4			24	Lanyard handles.....	H. C.		
1			6	Liquid pump.....	P. C.		
4			24	Loading barrows.....	H. C.		
4			24	Loading rammers.....	H. C.		

Equipment for units composing a regiment of 155-mm. howitzer matériel, model of 1918  
(Schneider) motorized, on war footing—Continued.

Number per organization.				Article.	Where carried.	Property classification.	
B.	H. C.	S. C.	R.			Class.	Division.
				<b>Tools and accessories for howitzer and howitzer carriage—Continued.</b>			
8			48	Loading rammer straps.....	H. C.		
1			6	Measure (1 liter cap).....	P. C.		
4			24	Pin drifts.....	T. B.		
2			12	Pressure gages.....	P. C.		
1			6	Pressure gage for reservoir.....	P. C.		
2			12	Pressure gage adapters.....	P. C.		
4			24	Rammers.....	H. C.		
4			24	Rammer straps.....	H. C.		
1			6	Reservoir for compressed gas with adapter.....	A. S. T.		
4			24	Retracting ropes with blocks.....	H. C.		
5			30	Screw drivers (5-inch blade).....	4-T. B. 1-P. C.		
1			6	Screw driver (3-inch blade).....	P. C.		
1			6	Slush brush.....	A. S. T.		
1			6	Spanner for gasket ring (axle housing).....	A. S. T.		
2			12	Spanners for pumps.....	P. C.		
4			24	Sponges.....	H. C.		
4			24	Tool kits each containing.....	T. B.		
				1 cross peen hammer.....	T. K.		
				1 drift (large bronze).....	T. K.		
				1 drift (small bronze).....	T. K.		
				1 file (6 inches, 3 square, dead smooth).....	T. K.		
				1 file (8 inches, hand) smooth.....	T. K.		
				1 file handle.....	T. K.		
				1 punch (small).....	T. K.		
				1 pliers, wire cutting (8 inches).....	T. K.		
				1 screw driver (3-inch blade).....	T. K.		
				1 screw slot wrench with blade.....	T. K.		
				1 screw wrench (8 inches).....	T. K.		
4			24	Vent cleaning drifts.....	T. B.		
4			24	Vent cleaning wires.....	T. B.		
8			48	Wheel mats.....	H. C.		
4			24	Wire, 20 gage copper (1-pound coil).....	T. B.		
2			12	Wrenches for filling pipe union.....	P. C.		
1			6	Wrench for piston rod nuts.....	P. C.		
4			24	Wrenches for filling plug.....	T. B.		
1			6	Wrench for air pump piston nut.....	P. C.		
2			12	Wrenches for filling needle valve.....	P. C.		
2			12	Wrenches for filling valve cap.....	P. C.		
2			12	Wrenches for gage cock.....	P. C.		
4			24	Wrenches for percussion hammer operating shaft nut.....	T. B.		
4			24	Wrenches for obturator spindle.....	T. B.		
4			24	Wrenches for obturator spindle plug.....	T. B.		
4			24	Wrenches, teat, for breech mechanism.....	T. B.		
				<b>Spare parts.</b>			
				<i>For the howitzer.</i>			
1			6	Breech mechanism (complete), including firing mechanism.....	A. S. T.		
4			24	Detents.....	T. B.		
2			12	Firing mechanism block latches.....	A. S. T.		
6			36	Firing mechanism block latch spring holders.....	A. S. T.		
2			12	Firing mechanism block latch springs.....	A. S. T.		
8			48	Firing mechanism block latch holders.....	A. S. T.		
2			12	Firing mechanism block latch holder screws.....	A. S. T.		
6			36	Firing mechanism block latch handles.....	A. S. T.		
6			36	Firing mechanism housings.....	A. S. T.		
6			36	Firing mechanism housing screws.....	A. S. T.		
6			36	Firing mechanism housing keys.....	A. S. T.		
6			36	Firing mechanism housing key springs.....	A. S. T.		
6			36	Firing mechanism housing key studs.....	A. S. T.		
6			36	Firing mechanism housing key spring rivets.....	A. S. T.		
6			36	Firing mechanism safety plungers.....	A. S. T.		
4			24	Firing mechanism safety plunger springs.....	T. B.		
8			48	Firing pin guides.....	A. S. T.		
12			72	Firing pins.....	8-T. B. 4-A. S. T.		
12			72	Firing pin springs.....	8-T. B. 4-A. S. T.		

IV

3

*Equipment for units composing a regiment of 155-mm. howitzer matériel, model of 1918 (Schneider) motorized, on war footing—Continued.*

Number per organization.				Article.	Where carried.	Property classification.	
B.	H. C.	S. C.	R.			Class.	Division.
				<b>Spare parts—Continued.</b>			
				<i>For the howitzer—Continued.</i>			
8			48	Firing pin housings.....	A. S. T.		
8			48	Firing mechanism blocks (complete).....	{A. T. B. {A. S. T.		
				Each consisting of—			
				1 firing mechanism block.....			
				1 firing mechanism block handle.....			
				1 firing pin.....			
				1 firing pin housing.....			
				1 firing pin housing safety screw.....			
				1 firing pin guide.....			
				1 firing pin spring.....			
				1 primer seat plug.....			
8			48	Firing mechanism block handles.....	A. S. T.		
8			48	Firing pin housing holding screws.....	A. S. T.		
4			24	Filling-in disks.....	A. S. T.		
8			48	Gas check pads.....	A. S. T.		
4			24	Obturator spindles.....	A. S. T.		
4			24	Obturator spindle plugs.....	A. S. T.		
6			36	Obturator spindle springs.....	A. S. T.		
6			36	Obturator spindle vent bushings.....	A. S. T.		
4			24	Percussion hammers.....	A. S. T.		
6			36	Percussion hammer lock bolts.....	A. S. T.		
6			36	Percussion hammer lock bolt springs.....	A. S. T.		
6			36	Percussion hammer lock bolt spring set screws.....	A. S. T.		
2			12	Percussion hammer lock housings.....	A. S. T.		
2			12	Percussion hammer lock housing screws.....	A. S. T.		
2			12	Percussion hammer lock housing set screws.....	A. S. T.		
2			12	Percussion hammer operating shafts.....	A. S. T.		
2			12	Percussion hammer operating shaft housings.....	A. S. T.		
2			12	Percussion hammer operating shaft housing control screws.....	A. S. T.		
4			24	Percussion hammer operating shaft collars.....	A. S. T.		
2			12	Percussion hammer operating shaft nuts.....	A. S. T.		
4			24	Percussion hammer shaft plungers.....	A. S. T.		
4			24	Percussion hammer shaft plunger springs.....	A. S. T.		
8			48	Primer seat plugs.....	{A. T. B. {A. S. T.		
2			12	Racks.....	A. S. T.		
2			12	Rack locks.....	A. S. T.		
4			24	Rack lock springs.....	T. B.		
4			24	Spindle plug gaskets.....	A. S. T.		
4			24	Spindle spring seats (front).....	A. S. T.		
4			24	Spindle spring seats (rear).....	A. S. T.		
4			24	Split rings (front).....	A. S. T.		
4			24	Split rings (rear).....	A. S. T.		
4			24	Split rings (small).....	A. S. T.		
				<i>(For the carriage.)</i>			
2			12	Axle cans, complete.....	A. S. T.		
2			12	Axle collars.....	A. S. T.		
2			12	Air tank head glands.....	A. S. T.		
1			6	Axle traveling lock.....	A. S. T.		
1			6	Axle traveling lock spring.....	A. S. T.		
8			48	Belleville springs.....	A. S. T.		
2			12	Bolt locks.....	A. S. T.		
1			6	Bolt, 12.25 by 42 mm., countersunk head, with nut and split pins.....	A. S. T.		
4			24	Bolts, 12 by 31 mm., with crown nuts and split pins.....	A. S. T.		
1			6	Bolts, 14 by 37 mm.....	A. S. T.		
2			12	Bolts, 18.5 by 73.5 mm., with crown nut, dowels and split pins.....	A. S. T.		
2			12	Bolts, 18.5 by 78 mm., with crown nut, dowels and split pins.....	A. S. T.		
2			12	Bolts, 12.25 by 40 mm., with crown nuts and split pins.....	A. S. T.		
2			12	Bolts, 6 by 36 mm., with nuts and split pins.....	A. S. T.		
4			24	Bolts, 10 by 28 mm., with crown nuts, washer, and split pins.....	A. S. T.		
1			6	Bolt, 10 by 25 mm., with crown nuts and split pins.....	A. S. T.		

IV 3

Equipment for units composing a regiment of 155-mm. howitzer matériel, model of 1918  
(Schneider) motorized, on war footing—Continued.

Number per organization.				Article.	Where carried.	Property classification.	
B.	H. C.	S. C.	R.			Class.	Division.
				<b>Spare parts—Continued.</b>			
				<i>(For the carriage)—Continued.</i>			
2				12 Bolts, 14.25 by 40 mm., with crown nuts and split pins.	A. S. T.		
4				24 Bolts, 14.25 by 42 mm., with crown nuts and split pins.	A. S. T.		
2				12 Bolts, 12.25 by 38 mm., with crown nuts and split pins.	A. S. T.		
2				12 Brake shaft keys.	A. S. T.		
2				12 Brake shoes.	A. S. T.		
1				6 Bushing, brake screw supporting.	A. S. T.		
1				6 Bushing, elevating worm wheel case (20 mm. diameter).	A. S. T.		
1				6 Bushing, elevating worm wheel case (25.1 mm. diameter).	A. S. T.		
1				6 Bushing, elevating worm wheel case (46 by 49 mm.).	A. S. T.		
1				6 Bushing, elevating worm wheel case (46 by 50 mm.).	A. S. T.		
1				6 Bushing, pinion shaft bracket.	A. S. T.		
1				6 Bushing, traversing gear case (15 mm. diameter).	A. S. T.		
2				12 Bushings, traversing gear cases (22 by 16 mm.).	A. S. T.		
1				6 Bushing, traversing gear cases (25 mm. diameter).	A. S. T.		
2				12 Cam screw, cradle traveling locks.	A. S. T.		
2				12 Cam screw, sleigh traveling locks.	A. S. T.		
1				6 Cap latch pin, cradle head.	A. S. T.		
2				12 Counter-recoil piston liners.	A. S. T.		
2				12 Counter-recoil piston lubricators.	A. S. T.		
1				6 Counter-recoil piston nut.	A. S. T.		
2				12 Counter-recoil piston nut liners.	A. S. T.		
2				12 Counter-recoil piston packing springs.	A. S. T.		
1				6 Counter-recoil piston rubber follower.	A. S. T.		
2				12 Counter-recoil piston rubber pads.	A. S. T.		
2				12 Counter-recoil rod lubricators.	A. S. T.		
1				6 Counter-recoil rod nut.	A. S. T.		
2				12 Counter-recoil rod packing springs.	A. S. T.		
1				6 Counter-recoil rod rubber follower.	A. S. T.		
2				12 Counter-recoil rod rubber pads.	A. S. T.		
8				48 Counter-recoil stops.	A. S. T.		
4				24 Counter-recoil valves.	T. B.		
1				6 Filling needle valve.	P. C.		
2				12 Filling plugs.	A. S. T.		
1				6 Firing mechanism striker.	A. S. T.		
2				12 Firing safety latches.	A. S. T.		
2				12 Gage cocks, complete.	A. S. T.		
2				12 Gaskets, 96 by 100 by 2 mm. (copper).	A. S. T.		
4				24 Gaskets, No. 1.	A. S. T.		
4				24 Gaskets, No. 2.	A. S. T.		
4				24 Gaskets, No. 3.	A. S. T.		
4				24 Gaskets, No. 4.	A. S. T.		
4				24 Gaskets, No. 5.	A. S. T.		
4				24 Gaskets, No. 6.	A. S. T.		
4				24 Gaskets, No. 7.	A. S. T.		
4				24 Gaskets, No. 8.	A. S. T.		
4				24 Gaskets, No. 9.	A. S. T.		
4				24 Gaskets, No. 10.	A. S. T.		
4				24 Gaskets, No. 12.	P. C.		
2				12 Gage cock valve disks.	A. S. T.		
4				24 Gaskets, 144 by 118 by 2 mm. (copper).	A. S. T.		
1				6 Gasket, dust cover.	A. S. T.		
6				36 Gaskets, filling plugs.	A. S. T.		
2				12 Hub liners (inner).	A. S. T.		
8				48 Hub liners (outer).	A. S. T.		
8				48 Hub liner screws (A = 13 mm.).	A. S. T.		
4				48 Hub liner screws (A = 14 mm.).	A. S. T.		
1				24 Handle return springs.	A. S. T.		
1				6 Latch shaft spring.	A. S. T.		
2				12 Latch spring (sight port shutter).	A. S. T.		
1				6 Linch pins, complete.	A. S. T.		
2				12 Lunette chain, complete.	A. S. T.		
1				12 Nuts, 6 mm.	A. S. T.		
1				6 Nut, 16 mm. (buffer rod).	A. S. T.		
2				12 Nut, 16 mm. (special).	A. S. T.		
4				24 Nuts, 16 mm. (brake details).	A. S. T.		
4				24 Nuts, 12 mm.	A. S. T.		

IV

3

Equipment for units composing a regiment of 155-mm. howitzer matériel, model of 1918  
(Schneider) motorized, on war footing—Continued.

Number per organization.				Article.	Where carried.	Property classification.	
B.	H. C.	S. C.	R.			Class.	Division.
				<b>Spare parts—Continued.</b>			
				(For the carriage)—Continued.			
2			12	Nuts, 12 mm.	A. S. T.		
32			192	Nuts, 14 mm.	A. S. T.		
6			36	Nuts, 18 mm.	A. S. T.		
2			12	Nuts, 0.375-inch.	A. S. T.		
2			12	Nuts, 0.5-inch.	A. S. T.		
2			12	Obturators, outer (counter-recoil rod).	A. S. T.		
2			12	Obturators, inner (counter-recoil rod).	A. S. T.		
2			12	Obturators, outer (recoil piston rod).	A. S. T.		
2			12	Obturators, inner (recoil piston rod).	A. S. T.		
2			12	Obturators, outer (counter-recoil piston).	A. S. T.		
2			12	Obturators, inner (counter-recoil piston).	A. S. T.		
2			12	Oil hole plugs.	A. S. T.		
10			60	Pins, split, 2 by 30 mm.	A. S. T.		
25			150	Pins, split, 3 by 45 mm.	A. S. T.		
25			150	Pins, split, 4 by 40 mm.	A. S. T.		
10			60	Pins, split, 5 by 24 mm.	A. S. T.		
5			30	Pins, split, 5 by 48 mm.	A. S. T.		
25			150	Pins, split, 6 by 60 mm.	A. S. T.		
5			30	Pins, split, 0.156 by 0.5 inch.	A. S. T.		
1			6	Pin, taper, 6 by 45 mm.	A. S. T.		
1			6	Piston rod lock.	A. S. T.		
2			12	Piston rod lubricators.	A. S. T.		
1			6	Piston rod packing seat.	A. S. T.		
2			12	Piston rod packing springs.	A. S. T.		
1			6	Piston rod rubber follower.	A. S. T.		
2			12	Piston rod rubber pad.	A. S. T.		
1			6	Plunger spring (axle traveling lock).	A. S. T.		
2			12	Plunger springs (cradle traveling lock).	A. S. T.		
1			6	Plunger spring (elevating handwheel).	A. S. T.		
2			12	Plunger springs (sleigh traveling lock).	A. S. T.		
1			6	Recoil indicator, complete.	A. S. T.		
1			6	Recoil piston rod nut.	A. S. T.		
2			12	Recoil piston liners.	A. S. T.		
1			6	Recoil piston rod plug.	A. S. T.		
2			12	Spade latch shaft nuts.	A. S. T.		
1			6	Spade traveling hook.	A. S. T.		
2			12	Spring cotters, with chains complete.	A. S. T.		
1			6	Spring cover, complete, 25 mm. long.	A. S. T.		
4			24	Spring covers, complete, 36 mm. long.	A. S. T.		
4			24	Spring covers, complete, 40 mm. long.	A. S. T.		
2			12	Screws, 4 by 6 mm., countersunk head.	A. S. T.		
8			48	Screws, 8 by 16.5 mm., countersunk head.	A. S. T.		
2			12	Screws, 4 by 7 mm., countersunk head.	A. S. T.		
4			24	Screws, 5 by 15 mm., countersunk head.	A. S. T.		
2			12	Screws, 6 by 13 mm., countersunk head.	A. S. T.		
2			12	Screws, 10 by 17 mm., countersunk head.	A. S. T.		
6			36	Screws, 14 by 19 mm., countersunk head.	A. S. T.		
4			24	Screws, 14 by 17 mm., countersunk head.	A. S. T.		
3			18	Screws, 6 by 15 mm., countersunk head.	A. S. T.		
2			12	Screws, 3 by 6 mm., headless.	A. S. T.		
2			12	Screws, 4 by 5 mm., headless.	A. S. T.		
9			12	Screws, 6 by 14 mm., headless.	A. S. T.		
12			54	Screws, 5 by 8 mm., special.	A. S. T.		
4			24	Screws, 6 by 13 mm., special.	A. S. T.		
1			6	Thrust bearings.	A. S. T.		
1			6	Thrust bearing adjuster.	A. S. T.		
1			6	Thrust bearing adjuster lock.	A. S. T.		
1			6	Trail box gasket with brass band.	A. S. T.		
2			12	Washers, 5 by 10 by 5 mm.	A. S. T.		
2			12	Washers, 6 by 12 by 4 mm.	A. S. T.		
12			72	Washers, 9.1 by 17 by 5.5 mm.	A. S. T.		
4			24	Washers, 10.75 by 20 by 2 mm.	A. S. T.		
2			12	Washers, 13 by 36 by 7 mm.	A. S. T.		
8			48	Washers, 14.05 by 32 by 3 mm.	A. S. T.		
2			12	Washers, 15 by 34 by 3 mm.	A. S. T.		
2			12	Washers, 17 by 28 by 6 mm.	A. S. T.		
2			12	Washers, 18 by 40 by 5 mm.	A. S. T.		
16			96	Washers, 19 by 38 by 4 mm.	A. S. T.		
2			12	Washers, 29.2 by 40.9 by 2 mm.	A. S. T.		
2			12	Washers, 26 by 58 by 5 mm.	A. S. T.		
4			24	Washers, round.	A. S. T.		
1			6	Wheel, complete (1,350 mm. dia.).	A. S. T.		

IV

3

Equipment for units composing a regiment of 155-mm. howitzer matériel, model of 1918 (Schneider) motorized, on war footing—Continued.

Number per organization.				Article.	Where carried.	Property classification.	
B.	H. C.	S. C.	R.			Class.	Division.
				<b>Spare parts—Continued.</b>			
				(For the accessories.)			
3			18	Adapter gaskets, No. 1.....	P. C.....		
3			18	Adapter gaskets, No. 2.....	P. C.....		
3			18	Adapter gaskets, No. 3.....	P. C.....		
3			18	Adapter gaskets, No. 4.....	P. C.....		
1			6	Connecting gasket (for air pump).....	A. S. T.....		
4			24	Corrector scale screws (for hand fuze setter).....	A. S. T.....		
12			72	Guide plate screws (for hand fuze setter).....	A. S. T.....		
8			48	Index bar screws (for hand fuze setter).....	A. S. T.....		
4			24	Index plungers (for hand fuze setter).....	A. S. T.....		
4			24	Index springs (for hand fuze setter).....	A. S. T.....		
8			48	Lenyards.....	T. B.....		
4			24	Lenyard handles.....	T. B.....		
4			24	Piston packings (for air pump).....	P. C.....		
4			24	Range index (for hand fuze setter).....	A. S. T.....		
16			96	Range ring screws (for hand fuze setter).....	A. S. T.....		
4			24	Stop in screws (for hand fuze setter).....	A. S. T.....		
1			6	Valve seat gasket (for air pump).....	P. C.....		
				<b>Tools and accessories for carriage limber.</b>			
8			48	Cases for lightening equipment.....	C. L.....		
4			24	Grease boxes.....	C. L.....		
8			48	Watering buckets (canvas).....	C. L.....		
				<b>Spare parts for carriage limber.</b>			
1			6	Axle cap, complete.....	A. S. T.....	IV	3
4			24	Collar disk bolts, with nuts.....	A. S. T.....		
1			6	Connecting pole hinge.....	A. S. T.....		
1			6	Connecting pole hinge plate.....	A. S. T.....		
1			6	Handy oiler (0.5 inch).....	A. S. T.....		
1			6	Hinge pin.....	A. S. T.....		
1			6	Hinge pin nut.....	A. S. T.....		
1			6	Hub liner (inner).....	A. S. T.....		
1			6	Hub liner (outer).....	A. S. T.....		
4			24	Hub liner screws (A=8 mm.).....	A. S. T.....		
4			24	Hub liner screws (A=10 mm.).....	A. S. T.....		
2			12	Linch pins.....	A. S. T.....		
2			12	Lunette pins.....	A. S. T.....		
1			6	Pintle yoke.....	A. S. T.....		
1			6	Pintle yoke rivet.....	A. S. T.....		
1			6	Pole supporting spring.....	A. S. T.....		
1			6	Prop chain (complete).....	A. S. T.....		
4			24	Pins, split (0.208 (4) by 2 inches).....	A. S. T.....		
4			24	Pins, split (7 by 70 mm.).....	A. S. T.....		
1			6	Safety chain, complete.....	A. S. T.....		
2			12	Screws, nut lock.....	A. S. T.....		
1			6	Spring bolt nut.....	A. S. T.....		
1			6	Wheel, complete (1,240 mm. diameter).....	A. S. T.....		
				<b>Tools and accessories for howitzer caisson.</b>			
11			66	Axes.....	C.....	IV	9
12			72	Bucket straps.....	C.....		
12			72	Caisson prop straps.....	C.....	IV	3
24			144	Dust guards for 60-inch wheel.....	C. W.....		
12			72	Fuze boxes (complete) for Mark III and IV fuzes.....	C.....	IV	9
36			216	Grip straps.....	C.....		
12			72	Hatchets.....	C.....	IV	9
12			72	Lanterns.....	C.....		
12			72	Lantern bracket pads.....	C.....	IV	3
12			72	Lantern straps.....	C.....		
44			264	Limber blanket straps (long).....	C.....	IV	3
44			264	Limber blanket straps (short).....	C.....		
12			72	Lunette straps.....	C.....	IV	9
12			72	Oil cans (2-gallon).....	C.....		
12			72	Paulins (12 by 12 feet).....	C.....	IV	9
36			216	Paulin straps.....	C.....		
12			72	Pickaxes.....	C.....	IV	9
12			72	Pick handle straps.....	C.....		
12			72	Picket ropes.....	C.....	IV	9
24			144	Picket rope straps.....	C.....		

Equipment for units composing a regiment of 155-mm. howitzer matériel, model of 1918 (Schneider) motorized, on war footing—Continued.

Number per organization.				Article.	Where carried.	Property classification.	
B.	H. C.	S. C.	R.			Class.	Division.
				<b>Tools and accessories for howitzer caisson—Continued.</b>			
6			36	Shovels (long handles).....	C.....	IV	9
6			36	Shovels (short handles).....	C.....		
12			72	Shovel handle straps.....	C.....		
12			72	Spanners (for 60-inch wheel).....	C.....	IV	3
12			72	Spanner straps.....	C.....		
12			72	Watering buckets (canvas).....	C.....	IV	9
12			72	Wrenches (0.625 inch and 0.75 inch).....	C.....		
				<b>Spare parts for howitzer caisson.</b>			
1			6	Apron hinges (female).....	A. S. T.....	IV	3
1			6	Apron hinges (female) (inner).....	A. S. T.....		
1			6	Apron hinges (female) (outer) (left).....	A. S. T.....		
1			6	Apron hinges (female) (outer) (right).....	A. S. T.....		
3			18	Apron hinges (male).....	A. S. T.....		
1			6	Apron latches (female).....	A. S. T.....		
1			6	Apron latches (male).....	A. S. T.....		
1			6	Axle bracket.....	A. S. T.....		
8			48	Axle bracket bushings.....	A. S. T.....		
2			12	Band guides.....	A. S. T.....		
32			192	Bellevillesprings.....	A. S. T.....		
4			24	Bolts (0.625 by 2.5 inches) (for pintle bearing).....	A. S. T.....		
2			12	Bolts (0.625 by 4.437 inches) (for prop).....	A. S. T.....		
2			12	Bolts (0.75 by 2.812 inches) (for pole socket).....	A. S. T.....		
2			12	Brake bands with linings.....	A. S. T.....		
6			36	Brake band linings.....	A. S. T.....		
2			12	Brake drums.....	A. S. T.....		
2			12	Brake levers.....	A. S. T.....		
2			12	Brake lever catches.....	A. S. T.....		
2			12	Brake lever hooks.....	A. S. T.....		
2			12	Brake lever pin washers.....	A. S. T.....		
2			12	Brake lever rods.....	A. S. T.....		
2			12	Brake lever stop rivets.....	A. S. T.....		
2			12	Brake rod ends.....	A. S. T.....		
2			12	Brake rods.....	A. S. T.....		
2			12	Brake rod levers.....	A. S. T.....		
2			12	Brake shaft levers.....	A. S. T.....		
12			72	Carrying springs.....	A. S. T.....		
2			12	Chain No. 16 (complete).....	A. S. T.....		
4			24	Connecting pole keys.....	A. S. T.....		
6			36	Door prosliding rivets.....	A. S. T.....		
3			18	Fastening levers.....	A. S. T.....		
3			18	Fastening lever pins (long).....	A. S. T.....		
3			18	Fastening lever pins (short).....	A. S. T.....		
3			18	Fastening springs.....	A. S. T.....		
6			36	Guide bolts and nuts.....	A. S. T.....		
3			18	Hub liners.....	A. S. T.....		
3			18	Lock washers (for wheels).....	A. S. T.....		
2			12	Locking hinge pins.....	A. S. T.....		
3			18	Locking lever pins.....	A. S. T.....		
2			12	Loose diaphragms (lower).....	A. S. T.....		
2			12	Loose diaphragms (upper).....	A. S. T.....		
2			12	Lunette pins.....	A. S. T.....		
6			36	Nuts, crown (forged steel No. 3) (0.75 inch).....	A. S. T.....		
6			36	Nuts, crown (0.75 by 0.625 inch thick).....	A. S. T.....		
8			48	Nuts, crown (0.625 inch).....	A. S. T.....		
6			36	Nuts, crown (0.75 inch).....	A. S. T.....		
6			36	Nuts, crown (0.5 inch).....	A. S. T.....		
6			36	Nuts, plain (0.375 inch).....	A. S. T.....		
6			36	Nuts, plain (0.625 inch).....	A. S. T.....		
6			36	Nuts, plain (0.75 inch).....	A. S. T.....		
12			72	Pins, bronze (0.187 by 0.562 inch).....	A. S. T.....		
25			150	Pins, split (0.125 by 0.5 inch).....	A. S. T.....		
20			120	Pins, split (0.125 by 1 inch).....	A. S. T.....		
12			72	Pins, split (0.125 by 1.5 inches).....	A. S. T.....		
20			120	Pins, split (0.156 by 1 inch).....	A. S. T.....		
50			300	Pins, split (0.156 by 1.75 inches).....	A. S. T.....		
25			150	Pins, split (0.203 by 1.25 inches).....	A. S. T.....		
12			72	Pins, split (0.25 by 1 inch).....	A. S. T.....		
12			72	Pins, split (0.25 by 2 inches).....	A. S. T.....		
4			24	Pins, steel (0.187 by 1.875 inches).....	A. S. T.....		
6			36	Pins, type A (0.368 by 1.76 inches).....	A. S. T.....		
3			18	Pins, type A (0.61 by 3.812 inches).....	A. S. T.....		
6			36	Pins, type A (0.61 by 1.875 inches).....	A. S. T.....		

Equipment for units composing a regiment of 155-mm. howitzer matériel, model of 1918 (Schneider), motorized, on war footing—Continued.

Number per organization.				Article.	Where carried.	Property classification.	
B.	H. C.	S. C.	R.			Class.	Division.
				<b>Spare parts for howitzer caisson—Contd.</b>			
6			36	Pins, type A (0.734 by 2.5 inches).....	A. S. T.	IV	3
4			24	Pins, type C (0.866 by 3.125 inches).....	A. S. T.		
4			24	Pins, type D (0.61 by 3.125 inches).....	A. S. T.		
2			12	Padlocks No. 850, with clevis.....	A. S. T.		
1			6	Pintle with bearing (complete).....	A. S. T.		
1			6	Pintle latches.....	A. S. T.		
4			24	Pintle latch pins.....	A. S. T.		
2			12	Pintle latch springs.....	A. S. T.		
2			12	Pintle springs.....	A. S. T.		
1			6	Pole, connecting (complete).....	A. S. T.		
1			6	Props (complete).....	A. S. T.		
200			1,200	Rivets (copper, flat head) (0.25 by 0.875 inch).....	A. S. T.		
8			48	Screws (0.375 by 1.25 inches, countersunk head).....	A. S. T.		
8			48	Screws (0.75 by 7.625 inches, flat flister).....	A. S. T.		
1			6	Segment racks.....	A. S. T.		
4			24	Spring bolts.....	A. S. T.		
4			24	Spring bolt heads.....	A. S. T.		
4			24	Spring bolt head locks.....	A. S. T.		
4			24	Spring bolt washers.....	A. S. T.		
3			18	Spring catches (implement fastening).....	A. S. T.		
3			18	Tap bolts (0.375 by 0.8 inch).....	A. S. T.		
6			36	Tap bolts (0.375 by 1 inch).....	A. S. T.		
24			144	Washers (0.25 inch).....	A. S. T.		
24			144	Washers (0.675 inch).....	A. S. T.		
12			72	Washers (0.75 inch).....	A. S. T.		
24			144	Washers, lock (0.375 inch).....	A. S. T.		
12			72	Washers, lock (0.625 inch).....	A. S. T.		
12			72	Washers, lock (0.75 inch).....	A. S. T.		
2			12	Wheels (complete).....	A. S. T.		
3			18	Wheel fastenings (complete).....	A. S. T.		
4			24	Wing nuts.....	A. S. T.		
3			18	Wing nut pins (for apron).....	A. S. T.		
2			12	Wing nut pins (for doors).....	A. S. T.		
4			24	Wing nut pin washers.....	A. S. T.		
				<b>Sighting equipment.</b>			
1			6	Bore sights (breach).....	A. S. T.		
1			6	Bore sights (muzzle).....	A. S. T.		
4			24	Gunner's quadrant.....	T. B.		
8			48	Lighting equipments (complete).....	C. L.		
				Each including—			
				1 aiming lamp with bracket cord and plug.....	C. L.		
				1 azimuth lamp with bracket cord and plug.....	C. L.		
				1 battery box with 4 dry cells.....	C. L.		
				1 lamp container.....	C. L.		
				1 level lamp with bracket cord and plug.....	C. L.		
				1 reel spindle for aiming lamp.....	C. L.		
				3 spools for lamp cords.....	C. L.		
4			24	Panoramic sights.....	H. C.		
4			24	Panoramic sight extensions.....	T. B.		
4			24	Peep sights.....	T. B.		
4			24	Quadrant sights, model of 1918 (Schneider).....	H. C.		
1			6	Wrench for quadrant sight bracket bolt.....	A. S. T.		
				<b>Spare parts for sighting equipment.</b>			
16			96	Dry cells (for lighting equipment).....	Cart.		
80			480	Lamps (for lighting equipment).....	C. L.		
1			6	Panoramic sight.....	A. S. T.		
1			6	Quadrant sight, model of 1918 (Schneider).....	A. S. T.		
				<b>Chassis equipment for 2-ton Nash truck chassis.</b>			
				NOTE.—Ammunition trucks, ammunition trucks equipped for passengers, tank trucks, telephone trucks, wireless trucks, artillery supply trucks, and artillery repair trucks are all equipped with 2-ton Nash truck chassis.			
15	12	12	114	Belt, fan <sup>1</sup> .....	Chassis.....	IV	9
15	12	12	114	Block, wheel assembled.....	do.....		
480	384	384	3,648	Bolt, nonskid chain eye (used only on trucks equipped with disk wheels).....	do.....		

<sup>1</sup> Carried in motor vehicle tool box.

Equipment for units composing a regiment of 155-mm. howitzer matériel, model of 1918 (Schneider), motorized, on war footing—Continued.

Number per organization.				Article.	Where carried.	Property classification.	
B.	H. C.	S. C.	R.			Class.	Division.
				<b>Chassis equipment for 2-ton Nash truck chassis—Continued.</b>			
15	12	12	114	Box, nonskid chain.....	Chassis		
45	36	36	342	Calcium carbide, pounds.....	do.		
490	384	384	3,648	Chains, nonskid (complete).....	do.		
15	12	12	114	Cover, radiator (furnished when required by special service).....	do.		
15	12	12	114	Cover, searchlight.....	do.		
15	12	12	114	Extinguisher, fire, Pyrene, quart size, filled, complete.....	do.		
				Including—			
				1 bracket.....	do.		
				6 bolts ( $\frac{3}{4}$ by $1\frac{1}{2}$ inch).....	do.		
				6 nuts, $\frac{3}{4}$ inch.....	do.		
				6 washers.....	do.		
960	768	768	7,206	Eyes (for nonskid chains, furnished only when truck is equipped with Clark disk wheels).....	do.		
15	12	12	114	Generator, acetylene, Solar No. 1012B (complete, including bracket and bolts).....	do.		
15	12	12	114	Handbook of the 2-ton truck chassis, Nash, model 4017A and 4017L, No. 1999. <sup>1</sup>	do.		
30	24	24	228	Key, switch <sup>1</sup> .....	do.		
30	24	24	228	Lamps, side, oil, Adelake type, No. 4481.....	do.		
15	12	12	114	Lamp, tail, oil, Adelake type, No. 4482.....	do.		
15	12	12	114	Lifter, valve <sup>1</sup> .....	do.		
15	12	12	114	Motor vehicle tool box, model of 1918, with contents hereinafter listed.....	do.		
480	384	384	3,648	Nut, $\frac{3}{4}$ -inch S. A. E. castle (used only on trucks equipped with disk wheels).....	do.		
240	192	192	1,824	Packing, water pump <sup>1</sup> .....	do.		
15	12	12	114	Paulins (12 by 12 feet).....	do.		
45	36	36	342	Rivets, transmission silent chain, complete <sup>1</sup> .....	do.		
15	12	12	114	Searchlights, acetylene, Solar No. 167, W. T. S., complete.....	do.		
				Including—			
				3 bolts ( $\frac{3}{4}$ by $1\frac{1}{2}$ inches).....	do.		
				1 bracket.....	do.		
				3 nuts ( $\frac{3}{4}$ -inch).....	do.		
				3 washers, lock ( $\frac{3}{4}$ -inch).....	do.		
				1 yoke, swivel.....	do.		
15	12	12	114	Signal, hand warning, Klaxon, No. K3.....	do.		
15	12	12	114	Speedometer, Stewart-Warner, No. 131M.....	do.		
15	12	12	114	Top for driver's seat, with storm apron and side curtains.....	do.		
15	12	12	114	Wrench, hub cap, No. 32773 <sup>1</sup> .....	do.		
15	12	12	114	Wrench, magneto <sup>1</sup> .....	do.		
15	12	12	114	Wrench, has, transmission spanner, No. 33166 <sup>1</sup> .....	do.		
15	12	12	114	Wrench, valve cap, No. 33166 <sup>1</sup> .....	do.		
15	12	12	114	Wrench, valve tappet <sup>1</sup> .....	do.		
				<b>Body equipment for ammunition trucks, ammunition trucks equipped for passengers, tank trucks, telephone trucks, and wireless trucks.</b>			
14	11	3	98	Axes.....	A. T.		
28	22	6	196	Buckets, canvas, water.....	A. T.		
28	22	6	196	Cans, 1-gallon, safety.....	A. T.		
14	11	3	98	Covers, canvas.....	A. T.		
28	22	6	196	Hatchets (for ammunition truck body).....	A. T.		
14	11	3	98	Kerosene, gallons.....	A. T.		
14	11	3	98	Lanterns, complete with globe and wick.....	A. T.		
14	11	3	98	Mats, coons, for floor and sides, sets.....	A. T.		
14	11	3	98	Mattocks, pick.....	A. T.		
14	11	3	98	Oil (medium gasoline engine), gallons.....	A. T.		
42	33	9	294	Pads, lantern bracket.....	A. T.		
14	11	3	98	Shovels, long handle.....	A. T.		
14	11	3	98	Shovels, short handle.....	A. T.		
56	44	12	392	Straps, 12 inches long, style AV, 7 holes.....	A. T.		
28	22	6	196	Straps, 15 inches long, style AV, 7 holes.....	A. T.		
14	11	3	98	Straps, 22.75 inches long, style AV, 7 holes.....	A. T.		
14	11	3	98	Straps, 15 inches long, style AVS, 7 holes.....	A. T.		
42	33	9	294	Straps, lantern.....	A. T.		

<sup>1</sup> Carried in motor vehicle tool box.

Equipment for units composing a regiment of 155-mm. howitzer matériel, model of 1918 (Schneider) motorized, on war footing—Continued.

Number per organization.				Article.	Where carried.	Property classification.	
B.	H. C.	S. C.	R.			Class.	Division.
				<b>Additional body equipment, ammunition trucks used as passenger cars.</b>			
8	9	.....	57	Seats, detachable, sets of 5.....	A. T.....		
				<b>Additional body equipment, tank trucks only.</b>			
		3	3	Carrier, barrel, complete.....	T. T.....		
		15	15	Drums, for gasoline, 55 gallons.....	T. T.....		
		6	6	Pumps, gasoline, rotary hand, with 15 feet of rubber hose.....	T. T.....		
				<b>Body equipment for artillery supply trucks.</b>			
1	1	6	13	Ax.....	A. S. T.....		
2	2	12	26	Buckets, water, canvas.....	A. S. T.....		
1	1	6	13	Can, safety, 1-gallon (for engine oil).....	A. S. T.....		
1	1	6	13	Cover, canvas, for body.....	A. S. T.....		
2	2	12	26	Hatchets.....	A. S. T.....		
1	1	6	13	Lantern.....	A. S. T.....		
2	2	12	26	Lantern bracket pads.....	A. S. T.....		
1	1	6	13	Oil, machine, gasoline engine, gallons.....	A. S. T.....		
1	1	6	13	Pick ax.....	A. A. T.....		
1	1	6	13	Pole ridge, wood.....	A. S. T.....		
2	2	12	26	Separators, transom ( $\frac{1}{2}$ by $5\frac{1}{2}$ inches), full weight from pipe.....	A. S. T.....	IV	9
2	2	12	26	Shovels, short handle.....	A. S. T.....		
1	1	6	13	Strap for ax handle.....	A. S. T.....		
2	2	12	26	Straps for hatchet handles.....	A. S. T.....		
2	2	12	26	Strap, lantern brackets.....	A. S. T.....		
1	1	6	13	Straps for pick ax handle.....	A. S. T.....		
2	2	12	26	Straps for short handle shovels.....	A. S. T.....		
1	1	6	13	Straps for water bucket.....	A. S. T.....		
1	1	6	13	Vice, Prentiss swivel jaw, complete.....	A. S. T.....		
				Including—			
				3 bolts ( $\frac{1}{2}$ by 2 inch, U. S. S.).....	A. S. T.....		
				3 nuts ( $\frac{1}{2}$ -inch, U. S. S.).....	A. S. T.....		
				3 washers ( $\frac{1}{2}$ -inch).....	A. S. T.....		
				3 washers, lock ( $\frac{1}{2}$ -inch).....	A. S. T.....		
				<b>Loads carried by artillery supply trucks.</b>			
				LOAD "A."			
				(Carried by artillery supply trucks assigned to batteries.)			
20	.....		120	Bolos, model 1917.....	A. S. T.....		
6	.....		36	Blades, awl, harness, assorted, Nos. 43-48, inclusive.....	A. S. T.....	X	9
10	.....		60	Buckles, bar, tongueless, $\frac{1}{2}$ -inch, brass.....	A. S. T.....		
15	.....		90	Buckles, bar, tongueless, 1-inch brass.....	A. S. T.....		
10	.....		60	Buckles, roller bar, $\frac{1}{2}$ -inch, bronze.....	A. S. T.....	X	10
50	.....		300	Buckles, roller, 1-inch, bronze.....	A. S. T.....		
20	.....		120	Buckles, satchel, $\frac{1}{2}$ -inch, bronze.....	A. S. T.....		
25	.....		150	Buckles, wire, $\frac{1}{2}$ -inch, brass.....	A. S. T.....		
1	.....		6	Brush, varnish, No. 4-O.....	A. S. T.....		
2	.....		12	Brushes, varnish, No. 5-O.....	A. S. T.....	X	10
10	.....		60	Buttons, style No. 1, with washers.....	A. S. T.....		
1	.....		6	Block, snatch, for 1.25-inch rope.....	A. S. T.....		
1	.....		6	Block, tackle, double, 8-inch.....	A. S. T.....		
2	.....		12	Buckets, water, galvanized steel.....	A. S. T.....	IV	9
1	.....		6	Box, oil.....	A. S. T.....		
				Each containing—			
				5 cans, 1 gallon capacity (to contain light slushing oil).....	O. B.....		
				5 oil, light slushing, gals.....	O. B.....		
				6 cans, $\frac{1}{2}$ gallon capacity; 1 will contain cosmic No. 80, soft; 1 will contain japan drier; 1 will contain neat's-foot oil; 1 will contain standard O. D. paint; 1 will contain special quick drying O. D. paint; 1 will contain sperm oil.....		X	10
				$\frac{1}{2}$ cosmic, No. 80 soft, gallon.....	O. B.....		
				$\frac{1}{2}$ drier, japan, gallon.....	O. B.....		
				$\frac{1}{2}$ oil, neat's-foot, gallon.....	O. B.....		
				$\frac{1}{2}$ oil, sperm, gallon.....	O. B.....		
				$\frac{1}{2}$ paint, standard O. D., gallon.....	O. B.....		
				$\frac{1}{2}$ paint, special quick drying, O. D., gallon.....	O. B.....		

Equipment for units composing a regiment of 155-mm. howitzer matériel, model of 1918 (Schneider) motorized, on war footing—Continued.

Number per organization.				Article.	Where carried.	Property classification.	
B.	H. C.	S. C.	R.			Class.	Division.
				<b>Loads carried by artillery supply trucks—Continued.</b>			
				<b>LOAD "A"—continued.</b>			
			150	Cable, high-tension, Packard, S. A. E., ingition, feet.....	A. S. T.	IV	9
25			12	Crowbar, 60-inch.....	A. S. T.		
2			150	Clips, end, 1-inch, brass.....	A. S. T.	X	10
25			30	Clips, end, 1-inch, brass.....	A. S. T.		
5			150	Clips, end, 1 1/4-inch, brass.....	A. S. T.	IV	9
25			6	Chest, spring.....	A. S. T.		
1			6	Chest, supply.....	A. S. T.		
2			12	Chest, grindstone.....	B. C.		
1			6	Chest, miscellaneous.....	B. C.		
1			6	Chest, carpenter's.....	B. C.		
1			6	Each containing—	B. C.		
				1 ax, bench, 7-inch blade.....	C. C.	X	9
				2 bags, canvas, for small stores.....	C. C.		
				1 bevel, 8-inch, rosewood handle, flush lever.....	C. C.		
				6 bits, auger, sizes, 0.25, 0.5, 0.75, 1, 1.25, 1.5 inches.....	C. C.		
				1 bit expansion, two cutters, 3/4 inch to 3 inches.....	C. C.		
				3 bits, screw driver, sizes, 0.375, 0.625, and 0.75 inch.....	C. C.		
				1 bit, wood, contersink, 0.625-inch.....	C. C.		
				1 brace, ratchet, 10-inch sweep.....	C. C.		
				3 chisels, socket, framing sizes, 0.75, 1, and 1.5 inches.....	C. C.		
				1 divider, wing, 10-inch.....	C. C.		
				4 drills, twist, sizes, 0.187-inch (3/16-inch) 0.218-inch (7/32-inch), 0.25-inch, and 0.281-inch (9/32-inch).....	C. C.		
				1 file, flat bastard, double cut, 10-inch.....	C. C.		
				6 files, saw, sizes, 4 and 6 inch.....	C. C.		
				1 gage, marking.....	C. C.		
				2 gages, socket, firmer, sizes 0.5 and 1 inch.....	C. C.		
				1 hammer, claw, adze eye, bell face, 1 pound 4 ounces.....	C. C.		
				2 handles, file, aluminum.....	C. C.		
				1 handle, tool, containing 10 tools.....	C. C.		
				1 knife, drawing, 9-inch blade.....	C. C.		
				1 mallet.....	C. C.		
				1 nail set.....	C. C.		
				1 oiler.....	C. C.		
				1 pincers, small, 8-inch.....	C. C.		
				1 plane, jack, wood, 16-inch, 2 1/4-inch double bit.....	C. C.		
				1 plane, smoothing, wood, 8-inch, 2-inch double bit.....	C. C.		
				1 plate, auger handle.....	C. C.		
				1 rasp, wood, 10-inch—half round.....	C. C.		
				1 reamer, half round.....	C. C.		
				1 rule, boxwood, 2 feet, 4 fold.....	C. C.		
				1 stone, oil, unmounted.....	C. C.		
				1 saw, crosscut, 24-inch, 7 point.....	C. C.		
				1 saw, rip, 24-inch, 5 point.....	C. C.		
				1 set, saw.....	C. C.		
				1 screw driver, 5-inch blade.....	C. C.		
				1 spoke shave, adjustable.....	C. C.		
				1 square, steel, 12-inch body and 8-inch tongue.....	C. C.		
				1 tape, linen, 100-foot.....	C. C.		
				1 vise, table, 2-inch jaw.....	C. C.		
				1 wrench, screw, 12-inch.....	C. C.		
1			6	Chest, fluid "A".....	A. S. T.	IV	9
				Each containing—		X	10
				2 boxes for stencil paste.....	F. C.		
				2 brushes, varnish No. 6-0.....	F. C.		
				4 brushes, paint, 4-inch flat (commercial).....	F. C.		

Equipment for units composing a regiment of 155-mm. howitzer matériel, model of 1918  
(Schneider) motorized, on war footing—Continued.

Number per organization.				Article.	Where carried.	Property classification.	
B.	H. C.	S. C.	R.			Class.	Division.
				<b>Loads carried by artillery supply trucks—Continued.</b>			
				LOAD "A"—continued.			
				Chest, fluid "A"—Continued.			
				Each containing—Continued.			
				20 cans, 2½ gallons capacity; 1 will contain kerosene; 6 will contain lubricating oil; 6 will contain recoil cylinder oil; 1 will contain camouflage paint, black; 2 will contain camouflage paint, cream; 2 will contain camouflage paint, green; 2 will contain camouflage paint, yellow.	F. C.		
				2½ kerosene, gallons.....	F. C.	X	10
				15 oil, lubricating, gallons.....	F. C.		
				15 oil, recoil cylinder, gallons.....	F. C.		
				2½ paint, camouflage, black, gallons.....	F. C.		
				5 paint, camouflage, cream, gallons.....	F. C.		
				5 paint, camouflage, green, gallons.....	F. C.		
				5 paint, camouflage, yellow, gallons.....	F. C.		
				5 paste, stencil, black, ounces.....	F. C.		
				5 paste, stencil, white, ounces.....	F. C.		
1			6	Chest, cleaning material and small stores.....	A. S. T.	IV	9
				Each containing—			
				3 brushes, sash No. 3.....	C. M. C.		
				3 brushes, sash No. 5.....	C. M. C.		
				1 brush, camel's-hair.....	C. M. C.		
				2 burners, lantern.....	C. M. C.		
				3 cans, 1-gallon capacity, for sal soda.....	C. M. C.		
				2 chamois skins.....	C. M. C.	X	10
				1 cloth, crocus, quire.....	C. M. C.		
				1 cloth, emery, No. 0, quire.....	C. M. C.		
				1 cloth, emery, No. 00, quire.....	C. M. C.		
				1 cloth, emery, No. ½, quire.....	C. M. C.		
				3 dressing, leather, russet, box.....	C. M. C.		
				2 globes, lantern.....	C. M. C.	IV	9
				1 outfit, marking, leather.....	C. M. C.		
				1 outfit, marking, metal.....	C. M. C.	X	9
				1 outfit, stencil.....	C. M. C.		
				1 oil, clock, 1-ounce bottle.....	C. M. C.		
				1 oil, raw linseed, 1-pint can.....	C. M. C.	X	10
				5½ petrolatum (in tin box), ounce.....	C. M. C.		
				1 stencil, Ordnance Department insignia.....	C. M. C.	X	9
				20 sal soda, pounds.....	C. M. C.		
				1 sandpaper, No. 00, quire.....	C. M. C.	X	10
				1 sandpaper, No. 2½, quire.....	C. M. C.		
				1 seal stamps (in stencil box).....	C. M. C.		
				5 wicks, lantern.....	C. M. C.	IV	9
23			138	Duck, cotton, olive drab, 22 inches, No. 1, yards.....	A. S. T.		
10			60	Fastener, Carr durable, complete.....	A. S. T.	X	10
10			60	Fastener, military.....	A. S. T.		
1			6	Grindstone, with frame, complete.....	G. C.	X	9
4			24	Handles, ax.....	A. S. T.		
4			24	Handles, hatchet.....	A. S. T.		
4			24	Handles, pickax.....	A. S. T.	IV	9
3			18	Handles, shovel, short.....	A. S. T.		
2			12	Handles, sledge, model 1907.....	A. S. T.		
2			12	Handles, shovel, long.....	A. S. T.		
1			6	Hafts, patent awl, with wrench.....	A. S. T.	X	9
2			12	Hook, side strap, wheel.....	A. S. T.		
1			6	Leather, bridle, back.....	A. S. T.		
1			6	Leather, collar, back.....	A. S. T.	X	10
1			6	Leather, latigo, side.....	A. S. T.		
1			6	Leather, harness, back.....	A. S. T.		
1			6	Magneto, Eisemann G-4, second edition, complete with impulse starter clockwise (for Nash truck).....	A. S. T.	IV	9
1			6	Needles, gloves', No. 3, papers.....	A. S. T.		
1			6	Needles, harness, No. 4, papers.....	A. S. T.		
1			6	Needles, harness, No. 5, papers.....	A. S. T.	X	9
1			6	Needles, harness, No. 6, papers.....	A. S. T.		
6			36	Pliers, wire cutting, 8 inches.....	A. S. T.		
24			144	Plugs, sparks, ¼ inch, S. A. E. standard "Titan".....	A. S. T.	IV	9

Equipment for units composing a regiment of 155-mm. howitzer matériel, model of 1918 (Schneider) motorized, on war footing—Continued.

Number per organization.				Article.	Where carried.	Property classification.	
B.	H. C.	S. C.	R.			Class.	Division.
				<b>Loads carried by artillery supply trucks—Continued.</b>			
				LOAD "A"—continued.			
1			6	Rope, manila, 1 inch diameter, 150 feet long.....	A. S. T.	X	10
100			600	Rope, manila, 3/4 inch diameter hemp, feet.....	A. S. T.		
1			6	Rivets and burrs, brass, 0.5 inch, No. 10, pounds.....	A. S. T.		
1			6	Rivets and burrs, brass, 0.625 inch, No. 10, pounds.....	A. S. T.	IV	9
20			120	Scabbards, bolo, model 1917.....	A. S. T.		
20			120	Sponges, 4 inches.....	A. S. T.		
2			12	Screws, wood, flat head, 1 inch brass, No. 6, 1 gross package.....	A. S. T.	X	10
2			12	Sheepskin, with wool on.....	A. S. T.		
1			6	Sledge, model 1907.....	A. S. T.		
12			72	Soap, castile, cakes.....	A. S. T.	X	10
4			24	Straps, 34 inches long, style DV, 8 holes.....	A. S. T.		
8			48	Straps, 52 inches long, style DV, 10 holes (the above straps are for use on the spring chest, fluid chest, and supply chests). Support, chest.....	A. S. T.		
1			6	Tape, friction, 1/2-inch, 1/2-pound rolls.....	A. S. T.	IV	9
4			24	Tape, rubber, 1/2-inch, 1/2-pound rolls.....	A. S. T.		
4			24	Tape, rubber, 1/2-inch, 1/2-pound rolls.....	A. S. T.		
1			6	Tacks, copper, No. 12, 1/2-pound paper.....	A. S. T.	X	10
1			6	Tacks, copper, No. 20, 1/2-pound paper.....	A. S. T.		
1			6	Thimble, aluminum-lined steel, size 1/2-inch.....	A. S. T.		
1			6	Thread, carpet No. 18, olive drab, pound.....	A. S. T.	X	10
1			6	Thread, shoe, No. 3, brown, pound.....	A. S. T.		
1			6	Thread, shoe, No. 10, brown, pound.....	A. S. T.		
1			6	Tool kit, saddler's sheepskin.....	A. S. T.	IV	9
				Each containing—			
				1 awl, pegging.....	S. T. K.		
				1 awl, seat, handled.....	S. T. K.		
				12 blades, awl, harness, assorted No. 43-48, inclusive.....	S. T. K.		
				2 blades, draw gage, with followers.....	S. T. K.		
				1 carriage, pricking, 3 wheels.....	S. T. K.		
				1 compass, 6-inch.....	S. T. K.		
				1 creaser, double, lignum-vitæ.....	S. T. K.		
				1 clamp, stitching.....	S. T. K.		
				1 gage, draw, brass without guard.....	S. T. K.		
				1 handle, peg awl, with wrench.....	S. T. K.		
				1 hammer, No. 3, riveting.....	S. T. K.		
				2 hfts, patent awl, with wrench.....	S. T. K.		
				1 knife, round.....	S. T. K.		
				1 knife, splitting, 6-inch.....	S. T. K.		
				1 knife, shoe, broad point.....	S. T. K.		
				1 knife, shoe, square point.....	S. T. K.		
				1 needlecase, leather.....	S. T. K.		
				1 needles, gloves', No. 3, paper.....	S. T. K.		
				2 needles, harness, No. 4, paper.....	S. T. K.		
				2 needles, harness, No. 5, paper.....	S. T. K.		
				2 needles, harness, No. 6, paper.....	S. T. K.		
				12 needles, sacking, assorted.....	S. T. K.		
				1 nippers, cutting, 10-inch.....	S. T. K.		
				1 distone, unmounted.....	S. T. K.		
				1 pliers, 6-inch.....	S. T. K.		
				4 punches, hand, round, Nos. 5, 7, 8, and 10.....	S. T. K.		
				1 punch, revolving, 4 tubes, Nos. 4, 5, 6, and 7.....	S. T. K.		
				1 palm, sewing, leather.....	S. T. K.		
				1 rule, boxwood, 2-foot, 4-fold.....	S. T. K.		
				1 set, rivet.....	S. T. K.		
				1 shearer, steel.....	S. T. K.		
				1 shears, 10-inch bent trimmers.....	S. T. K.		
				1 screw driver, 3-inch blade.....	S. T. K.		
				1 tool, edge, No. 1.....	S. T. K.		
				1 tool, edge, No. 2.....	S. T. K.		
				1 tool, claw.....	S. T. K.		
				2 thimbles, best aluminum lined, 2 sizes.....	S. T. K.		

Equipment for units composing a regiment of 155-mm. howitzer matériel, model of 1918 (Schneider) motorized, on war footing—Continued.

Number per organization.				Article.	Where carried.	Property classification.	
B.	H. C.	S. C.	R.			Class.	Division.
				<b>Loads carried by artillery supply trucks—Continued.</b>			
				LOAD "B-1."			
				(Carried by artillery supply trucks assigned to supply company.)			
		3	3	Chest, for duplex chain block (2-ton).....	B. C.....	IV	9
		3	3	Block, duplex chain, Y. & T., 2-ton.....	B. C.....		
		3	3	Chest, fluid, "B".....	A. S. T.....		
				Containing—			
				20 cans, 2½ gallons capacity (3 will contain cup grease, 7 will contain transmission oil, 10 will contain gasoline engine oil).	F. C.....		
				7½ grease, cup, gallons.....	F. C.....	X	10
				17½ oil, transmission, gallons.....	F. C.....		
				25 oil, medium, gasoline engine, gallons.....	F. C.....		
		6	6	Chests, supply.....	A. S. T.....	IV	9
		3	3	Chest, spring.....	A. S. T.....		
		24	24	Straps, 52-inch, style DV, 10 holes.....	A. S. T.....		
		12	12	Straps, 34-inch, style DV, 8 holes.....	A. S. T.....	X	10
		3	3	Support, chest.....	A. S. T.....		
		150	150	Waste, white cotton, pounds.....	A. S. T.....		
		12	12	Connecting rod, complete.....	A. S. T.....	IV	9
		48	48	Connecting rod piston pin bushing.....	A. S. T.....		
		144	144	Connecting rod bearing (upper half).....	A. S. T.....		
		144	144	Connecting rod bearing (lower half).....	A. S. T.....	X	10
		288	288	Connecting rod bearing shim (plain).....	A. S. T.....		
		288	288	Connecting rod bearing shim (laminated).....	A. S. T.....		
		192	192	Connecting rod bolt.....	A. S. T.....	IV	9
		36	36	Oil pan gasket (right).....	A. S. T.....		
		36	36	Oil pan gasket (left).....	A. S. T.....		
		24	24	Crank shaft shim.....	A. S. T.....	IV	9
		30	30	Crank shaft starting crank jaw.....	A. S. T.....		
		12	12	Crank shaft center bearing (upper).....	A. S. T.....		
		12	12	Crank shaft center bearing (lower).....	A. S. T.....	X	10
		12	12	Crank shaft front bearing (upper).....	A. S. T.....		
		12	12	Crank shaft front bearing (lower).....	A. S. T.....		
		24	24	Crank shaft front bearing shim (laminated).....	A. S. T.....	IV	9
		12	12	Crank shaft rear bearing (upper).....	A. S. T.....		
		12	12	Crank shaft rear bearing (lower).....	A. S. T.....		
		24	24	Crank shaft rear bearing shim (laminated).....	A. S. T.....	X	10
		18	18	Valve chamber plug (intake).....	A. S. T.....		
		96	96	Valve chamber plug gasket.....	A. S. T.....		
		144	144	Exhaust manifold gasket.....	A. S. T.....	IV	9
		144	144	Intake pipe gasket.....	A. S. T.....		
		12	12	Oil pump, complete.....	A. S. T.....		
		12	12	Oil pump screen.....	A. S. T.....	IV	9
		12	12	Oil pump screen cover gasket.....	A. S. T.....		
		24	24	Piston (standard).....	A. S. T.....		
		144	144	Piston ring (standard).....	A. S. T.....	X	10
		48	48	Piston pin.....	A. S. T.....		
		48	48	Piston pin set screw.....	A. S. T.....		
		30	30	Starting crank clutch.....	A. S. T.....	IV	9
		24	24	Starting crank shaft spring.....	A. S. T.....		
		72	72	Valve (exhaust and intake).....	A. S. T.....		
		96	96	Valve spring.....	A. S. T.....	X	10
		96	96	Valve spring retainer.....	A. S. T.....		
		96	96	Valve spring retainer lock.....	A. S. T.....		
		18	18	Valve tappet.....	A. S. T.....	IV	9
		96	96	Valve tappet adjusting screw.....	A. S. T.....		
		96	96	Valve tappet adjusting screw nut.....	A. S. T.....		
		6	6	Water pump, complete.....	A. S. T.....	X	10
		192	192	Water pump packing.....	A. S. T.....		
		6	6	Water pump packing nut, rear (left-hand thread).....	A. S. T.....		
		6	6	Water pump packing nut, front (right-hand thread).....	A. S. T.....	IV	9
		12	12	Water pump connection to cylinder gasket.....	A. S. T.....		
		24	24	Starting crank assembly.....	A. S. T.....		
		12	12	Starting crank swivel.....	A. S. T.....	X	10
		18	18	Breaker, complete (clockwise).....	A. S. T.....		
		72	72	Breaker, spring (long flat).....	A. S. T.....		
		48	48	Breaker contact screw (platinum contact).....	A. S. T.....		

Equipment for units composing a regiment of 155-mm. howitzer materiel, model of 1918  
(Schneider) motorized, on war footing—Continued.

Number per organization.				Article.	Where carried.	Property classification.	
B.	H.C.	S.C.	R.			Class.	Division.
<b>Loads carried by artillery supply trucks—</b>							
<b>Continued.</b>							
<b>LOAD "B-1"—continued.</b>							
		48	48	Breaker rocker arm (platinum contact).....	A. S. T.		
		6	6	Breaker timing lever complete with cams.....	A. S. T.		
		24	24	Breaker end cap with short circuit brush.....	A. S. T.		
		3	3	Distributor plate, complete.....	A. S. T.		
		48	48	Distributor plate collector carbon brush.....	A. S. T.		
		120	120	Distributor carbon brush with spring.....	A. S. T.		
		96	96	Spark plug (Titan, 1/4-inch).....	A. S. T.		
		96	96	Spark plug gasket.....	A. S. T.		
		12	12	Carburetor, complete (Stromberg M-2).....	A. S. T.		
		12	12	Floot.....	A. S. T.		
		12	12	High-speed needle valve.....	A. S. T.		
		12	12	Needle valve.....	A. S. T.		
		24	24	Strainer.....	A. S. T.		
		12	12	Strainer body.....	A. S. T.		
		24	24	Strainer body drain plug.....	A. S. T.		
		12	12	Strainer body stud.....	A. S. T.		
		12	12	Throttle stop set screw.....	A. S. T.		
		12	12	Throttle valve screw.....	A. S. T.		
		48	48	Carburetor gasket.....	A. S. T.		
		12	12	Fan blade and hub.....	A. S. T.		
		24	24	Fan shaft ball bearing.....	A. S. T.		
		72	72	Fan belt.....	A. S. T.		
		12	12	Governor flange gasket (upper).....	A. S. T.		
		12	12	Governor flange gasket (lower).....	A. S. T.		
		36	36	Radiator tank gasket.....	A. S. T.		
		3	3	Radiator core, complete.....	A. S. T.		
		24	24	Radiator inlet hose.....	A. S. T.		
		36	36	Radiator outlet hose.....	A. S. T.		
		12	12	Radiator brace rod (forked).....	A. S. T.		
		12	12	Radiator brace rod end (front).....	A. S. T.		
		30	30	Auxiliary tank to gasoline tank tube.....	A. S. T.		
		24	24	Gasoline tank cock.....	A. S. T.		
		12	12	Gasoline tank filler cap.....	A. S. T.		
		12	12	Gasoline strainer, complete.....	A. S. T.		
		12	12	Clutch drive plate (4-spline).....	A. S. T.		
		72	72	Clutch facing.....	A. S. T.		
		12	12	Clutch lever operating collar bearing.....	A. S. T.		
		6	6	Clutch spring.....	A. S. T.		
		12	12	Clutch throwout sleeve thrust bearing.....	A. S. T.		
		48	48	Clutch brake lining.....	A. S. T.		
		3	3	Chain (62 links).....	A. S. T.		
		12	12	Layshaft drive gear.....	A. S. T.		
		3	3	Layshaft third-speed drive gear.....	A. S. T.		
		3	3	Layshaft first-speed slide gear.....	A. S. T.		
		3	3	Layshaft second-speed slide gear.....	A. S. T.		
		3	3	Reverse gear.....	A. S. T.		
		3	3	Reverse rocker tube, complete.....	A. S. T.		
		6	6	Spline shaft drive sprocket, type II with gear 3015511 and screws.....	A. S. T.		
		12	12	Drive sprocket gear type II, used with sprocket 35419, type II.....	A. S. T.		
		36	36	Drive sprocket screw gear, used with type II sprocket and gear only.....	A. S. T.		
		12	12	Differential case bearing cone and rollers.....	A. S. T.		
		6	6	Differential bear assembly, with housing, com- plete, front and rear.....	A. S. T.		
		6	6	Pinion interbearing cone and rollers.....	A. S. T.		
		6	6	Pinion shaft sleeve and bearing cup.....	A. S. T.		
		6	6	Pinion shaft outer bearing cone and rollers.....	A. S. T.		
		6	6	Steering knuckle arm, complete (front left).....	A. S. T.		
		6	6	Steering knuckle arm, complete (front right).....	A. S. T.		
		72	72	Spring rebound clip (fifth leaf, rear).....	A. S. T.		
		12	12	Spring shackle.....	A. S. T.		
		12	12	Spring plate (upper).....	A. S. T.		
		72	72	Spring shackle bolt.....	A. S. T.		
		192	192	Spring clip bolt.....	A. S. T.		
		48	48	Front and rear spring rear hanger bushing.....	A. S. T.		
		96	96	Steering knuckle felt.....	A. S. T.		
		24	24	Steering knuckle pin bearing cone.....	A. S. T.		
		24	24	Steering knuckle pin bearing and retainer.....	A. S. T.		

IV

9

Equipment for units composing a regiment of 155-mm. howitzer matériel, model of 1918  
(Schneider) motorized, on war footing—Continued.

Number per organization.				Article.	Where carried.	Property classification.	
B.	H. C.	S. C.	R.			Class.	Division.
<b>Loads carried by artillery supply trucks—</b>							
<b>Continued.</b>							
LOAD "B-1"—continued.							
		24	24	Steering knuckle pin bearing cup	A. S. T.		
		6	6	Steering tie-rod, complete	A. S. T.		
		12	12	Steering tube and steering arm ball	A. S. T.		
		12	12	Steering drag link, complete	A. S. T.		
		36	36	Transmission brake band lining	A. S. T.		
		72	72	Wheel brake band lining	A. S. T.		
		6	6	Wheel drive pinion	A. S. T.		
		12	12	Wheel drive pinion bearing assembly, large (Bock 357)	A. S. T.		
		12	12	Wheel drive pinion bearing assembly, small (Bock 315)	A. S. T.		
		24	24	Wheel hub cap	A. S. T.		
		24	24	Wheel hub cap lock wire	A. S. T.		
		48	48	Wheel brake anchor spring	A. S. T.		
		48	48	Wheel brake release spring	A. S. T.		
		6	6	Axle propeller shaft with universal joints	A. S. T.		
		144	144	Universal joint casing oil plug	A. S. T.		
		18	18	Universal joint spider	A. S. T.		
		192	192	Universal joint spider bushing	A. S. T.		
		6	6	Spring, complete, front (9 leaves)	A. S. T.		
		6	6	Spring, complete, rear (8 leaves) (can be used front or rear)	A. S. T.		
		24	24	Spring, main leaf (rear) (can be used front or rear)	A. S. T.		
		72	72	Spring center bolt	A. S. T.		
		72	72	Spring rebound clip (fifth leaf, front)	A. S. T.		
		12	12	Wheel bearing, Timken, outer	A. S. T.		
				Felt washers:			
		300	300	Differential housing cap felt washer	A. S. T.		
		120	120	Bearing cage felt washer	A. S. T.		
		240	240	Countershaft bearing cap felt washer	A. S. T.		
		120	120	Spline shaft bearing cap felt washer	A. S. T.		
				Steel balls:			
		60	60	1/2 inch diameter	A. S. T.		
		30	30	3/4 inch diameter	A. S. T.		
		150	150	1 inch diameter	A. S. T.		
				Ball joints:			
		60	60	10-32	A. S. T.		
		60	60	1-20	A. S. T.		
				Bolts:			
		240	240	1-24 by 1 1/4 inches, hexagon head	A. S. T.		
		30	30	1-16 by 2 1/4 inches, hexagon head	A. S. T.		
		60	60	1-16 by 1 1/2 inches, hexagon head	A. S. T.		
		30	30	1-24 by 4 1/4 inches, hexagon head	A. S. T.		
		300	300	1-16 by 3 1/2 inches, hexagon head machine	A. S. T.		
		60	60	1-20 by 2 1/2 inches, hexagon head	A. S. T.		
		60	60	1-18 by 2 1/2 inches, hexagon head	A. S. T.		
		60	60	1-18 by 5 1/4 inches, square head machine	A. S. T.		
		150	150	1-16 by 2 1/2 inches, square head machine	A. S. T.		
		60	60	1-16 by 1 1/2 inches, square head machine	A. S. T.		
		60	60	1-16 by 1 1/4 inches, carriage	A. S. T.		
				Pipe connections:			
		60	60	1-18 by 1 1/2 inches, connection	A. S. T.		
		60	60	1-18 by 1 1/4 inches, connection	A. S. T.		
				Cap screws, hexagon head:			
		120	120	1-20 by 1 1/4 inches	A. S. T.		
		180	180	1-28 by 1 inch	A. S. T.		
		300	300	1-18 by 1 1/2 inches	A. S. T.		
		60	60	1-24 by 1 1/4 inches	A. S. T.		
		120	120	1-16 by 3/4 inch	A. S. T.		
		240	240	1-16 by 2 1/4 inches	A. S. T.		
		120	120	1-14 by 1 1/4 inches	A. S. T.		
		120	120	1-20 by 3/4 inch	A. S. T.		
		240	240	1-13 by 2 1/4 inches	A. S. T.		
		60	60	1-20 by 1 1/4 inches	A. S. T.		
				Cap screws, standard:			
		120	120	1-18 by 1 inch	A. S. T.		
		240	240	1-18 by 1 1/4 inches	A. S. T.		
		120	120	1-24 by 1 1/4 inches	A. S. T.		

IV

9

Equipment for units composing a regiment of 155-mm. howitzer matériel, model of 1918 (Schneider) motorized, on war footing—Continued.

Number per organization.				Article.	Where carried.	Property classification.	
B.	H. C.	S. C.	R.			Class.	Division.
				<b>Loads carried by artillery supply trucks—Continued.</b>			
				LOAD "B-1"—continued.			
				Cap screws, standard—Continued.			
		240	240	1/4-24 by 1 1/2 inches.....	A. S. T.		
		300	300	1/4-16 by 1 inch.....	A. S. T.		
		300	300	1/4-16 by 1 1/2 inches.....	A. S. T.		
		120	120	1/4-24 by 1 inch.....	A. S. T.		
		300	300	1/4-24 by 1 1/2 inches.....	A. S. T.		
		120	120	1/4-24 by 1 1/4 inches.....	A. S. T.		
		240	240	1/4-24 by 2 1/2 inches.....	A. S. T.		
		120	120	1/4-14 by 1 inch.....	A. S. T.		
		120	120	1/4-20 by 2 inches.....	A. S. T.		
		120	120	1/4-13 by 1 1/4 inches.....	A. S. T.		
		240	240	1/4-20 by 2 1/2 inches.....	A. S. T.		
		150	150	1/4-20 by 3 inches.....	A. S. T.		
				Cap screws, fillister head:			
		120	120	No. 14, 20 by 1/2 inch.....	A. S. T.		
		150	150	1/4-20 by 1/2 inch.....	A. S. T.		
		150	150	1/4-28 by 1/2 inch.....	A. S. T.		
		120	120	1/4-20 by 1/2 inch.....	A. S. T.		
		120	120	1/4-18 by 1 1/2 inches.....	A. S. T.		
				Machine screws:			
		240	240	No. 8, 32 by 1/2 inch, round head.....	A. S. T.		
		180	180	No. 10, 32 by 1/2 inch, round head.....	A. S. T.		
		240	240	No. 14, 20 by 1/2 inch, round head.....	A. S. T.		
		120	120	No. 10, 32 by 1/2 inch, flat head.....	A. S. T.		
		150	150	No. 10, 32 by 1/2 inch, flat head.....	A. S. T.		
		150	150	No. 10, 24 by 1/2 inch, flat head.....	A. S. T.		
				Wood screws:			
		240	240	No. 10 by 1 inch, flat head.....	A. S. T.		
		240	240	No. 12 by 1 1/2 inches, flat head.....	A. S. T.		
				Set screws:			
		120	120	1/4-18 by 1/2 inch.....	A. S. T.		
		120	120	1/4-20 by 1/2 inch, headless.....	A. S. T.		
		120	120	1/4-18 by 1/2 inch, drill head screw.....	A. S. T.		
		120	120	1/4-20 by 1 1/2 inches, drill head screw.....	A. S. T.		
				Studs:			
		60	60	1/4-14 by 5/8 inches.....	A. S. T.		
		120	120	1/4-13 by 2 1/4 inches.....	A. S. T.		
		60	60	1/4-13 by 3 1/2 inches.....	A. S. T.		
		60	60	1/4-16 by 1 1/2 inches.....	A. S. T.		
				Hexagon nuts:			
		240	240	1/4-20 by 1/2 inch.....	A. S. T.		
		240	240	1/4-28 by 1/2 inch.....	A. S. T.		
		240	240	1/4-18 by 1/2 inch.....	A. S. T.		
		240	240	1/4-18 by 1/2 inch.....	A. S. T.		
		240	240	1/4-24 by 1/2 inch.....	A. S. T.		
		240	240	1/4-16 by 1/2 inch.....	A. S. T.		
		240	240	1/4-24 by 1/2 inch.....	A. S. T.		
		120	120	1/4-16 by 1/2 inch.....	A. S. T.		
		120	120	1/4-22 by 1/2 inch.....	A. S. T.		
		120	120	1/4-22 by 1/2 inch (left hand thread).....	A. S. T.		
		60	60	1/4-14 by 1/2 inch.....	A. S. T.		
		60	60	1/4-20 by 1/2 inch.....	A. S. T.		
		240	240	1/4-13 by 1/2 inch.....	A. S. T.		
		240	240	1/4-20 by 1/2 inch.....	A. S. T.		
		240	240	1/4-16 by 1 1/2 inches.....	A. S. T.		
		30	30	1/4-14 by 1/2 inch (left hand thread).....	A. S. T.		
		60	60	1/4-14 by 1/2 inch.....	A. S. T.		
		60	60	1/4-20 by 1 1/2 inches.....	A. S. T.		
		30	30	1/4-20 by 1 1/2 inches.....	A. S. T.		
				Slotted nuts:			
		60	60	1/4-16 by 1/2 inch.....	A. S. T.		
		60	60	1/4-24 by 1/2 inch.....	A. S. T.		
		60	60	1/4-14 by 1/2 inch.....	A. S. T.		
		300	300	1/4-20 by 1/2 inch.....	A. S. T.		
		60	60	1/4-13 by 1/2 inch.....	A. S. T.		
		60	60	1/4-20 by 1/2 inch.....	A. S. T.		
		150	150	1/4-20 by 1/2 inch.....	A. S. T.		
		60	60	1/4-13 by 1/2 inch.....	A. S. T.		
		90	90	1/4-18 by 1 1/2 inches.....	A. S. T.		
		60	60	1/4-18 by 1/2 inch.....	A. S. T.		
		60	60	1/4-14 by 1 1/2 inches.....	A. S. T.		
		60	60	1/4-16 by 1 1/2 inches.....	A. S. T.		
		60	60	1/4-16 by 2 1/2 inches.....	A. S. T.		

IV 9

Equipment for units composing a regiment of 155-mm. howitzer matériel, model of 1918 (Schneider) motorized, on war footing—Continued.

Number per organization.				Article.	Where carried.	Property classification.		
B.	H. C.	S. C.	R.			Class.	Division.	
<b>Loads carried by artillery supply trucks—Continued.</b>								
LOAD "B-1"—continued.								
Crown nuts:								
		60	60	1-28 by 1/2 inch	A. S. T.			
		120	120	1-24 by 1/2 inch	A. S. T.			
		60	60	1-24 by 1/4 inch	A. S. T.			
		300	300	1-20 by 1/2 inch	A. S. T.			
		120	120	1-16 by 1 1/4 inches	A. S. T.			
		150	150	1-20 by 1 1/2 inches	A. S. T.			
		150	150	1-20 by 1 1/4 inches	A. S. T.			
		150	150	1-18 by 1 1/2 inch	A. S. T.			
		300	300	1-8 by 1 1/4 inches	A. S. T.			
Machine screw nuts:								
		150	150	No. 10, 32 by 1/2 inch hexagon	A. S. T.			
		150	150	No. 12, 24 by 1/2 inch, hexagon	A. S. T.			
		150	150	No. 14, 20 by 1/2 inch, hexagon	A. S. T.			
		150	150	No. 10, 32 by 3/4 inch, hexagon	A. S. T.			
		150	150	No. 14, 20 by 1/2 inch, hexagon	A. S. T.			
		150	150	1-24 by 1/2 inch, square	A. S. T.			
		150	150	No. 8, 32 by 1 1/4 inch, square	A. S. T.			
		150	150	No. 10, 32 by 1 1/2 inch, square	A. S. T.			
		150	150	No. 14, 20 by 1 1/2 inch, square	A. S. T.			
		150	150	1-20 by 1/2 inch, winged nut	A. S. T.			
		120	120	1-32 by 1/2 inch, union nut	A. S. T.			
		240	240	1-18 by 1/2 inch, union nut	A. S. T.			
Cotter pins:								
		4,500	4,500	1/4 by 1/2 inch	A. S. T.			
		7,500	7,500	1/4 by 1 1/4 inches	A. S. T.			
		6,000	6,000	1/4 by 1 1/2 inches	A. S. T.			
		3,000	3,000	1/4 by 2 1/4 inches	A. S. T.			
		6,000	6,000	1/4 by 1 1/2 inches	A. S. T.			
Clevis pins:								
		120	120	1/2 by 1 inch	A. S. T.			
		120	120	1/2 by 1 inch	A. S. T.			
		120	120	1/2 by 1 inch	A. S. T.			
		600	600	1/2 by 1 1/4 inches	A. S. T.			
		120	120	1/2 by 1 1/4 inches	A. S. T.			
		60	60	1/2 by 1 1/2 inches	A. S. T.			
		150	150	1/2 by 1 1/2 inches	A. S. T.			
		60	60	1/2 by 1 1/2 inches	A. S. T.			
Pins:								
		60	60	1/4 by 1 inch	A. S. T.			
		60	60	1/4 by 1 1/4 inch	A. S. T.			
		120	120	1/4 by 1 inch	A. S. T.			
		60	60	1/4 by 1 inch	A. S. T.			
		120	120	1/4 by 1 inch	A. S. T.			
		120	120	1/4 by 1 1/4 inches	A. S. T.			
		60	60	1/4 by 1 inch	A. S. T.			
		60	60	1/4 by 1 1/4 inches	A. S. T.			
		120	120	1/4 by 2 1/4 inches	A. S. T.			
		60	60	1/4 by 1 1/2 inches	A. S. T.			
		60	60	1/4 by 1 1/2 inches	A. S. T.			
Taper pins:								
		150	150	1/4 by 1 inch	A. S. T.			
		150	150	1/4 by 1 1/4 inches	A. S. T.			
		150	150	1/4 by 1 inch	A. S. T.			
		150	150	1/4 by 1 1/4 inches	A. S. T.			
		150	150	1/4 by 1 1/4 inches	A. S. T.			
		150	150	1/4 by 1 1/4 inches	A. S. T.			
Keys:								
		150	150	1/4 by 1 1/4 by 1/4 inch, Woodruff	A. S. T.			
		240	240	1/4 by 1/2 by 1/4 inch, Woodruff	A. S. T.			
		150	150	1/4 by 1/2 by 1/4 inch, Woodruff	A. S. T.			
		150	150	1/4 by 1/2 by 1/4 inch, Woodruff	A. S. T.			
		240	240	1/4 by 1/2 by 1/4 inch, Woodruff	A. S. T.			
		150	150	1/4 by 1/2 by 1/4 inch, Woodruff	A. S. T.			
		150	150	1/4 by 1/2 by 1/4 inch, Woodruff	A. S. T.			
		150	150	1/4 by 1/2 by 1/4 inch, Woodruff	A. S. T.			
		150	150	1/4 by 1/2 by 1/4 inch, Woodruff	A. S. T.			
		150	150	1/4 by 1/2 by 1/4 inch, Woodruff	A. S. T.			
		150	150	1/4 by 1/2 by 1/4 inch, Woodruff	A. S. T.			
		150	150	1/4 by 1/2 by 1/4 inch, Woodruff	A. S. T.			
		150	150	1/4 by 1/2 by 1/4 inch, Woodruff	A. S. T.			
		180	180	1/4 by 1/2 by 2 1/4 inches, straight key	A. S. T.			

IV 9

Equipment for units composing a regiment of 155-mm. howitzer matériel, model of 1918 (Schneider) motorized, on war footing—Continued.

Number per organization.				Article.	Where carried.	Property classification.	
B.	H. C.	S. C.	R.			Class.	Division.
<b>Loads carried by artillery supply trucks—Continued.</b>							
LOAD "B-1"—continued.							
Keys—Continued.							
		180	180	by 1/2 by 1 1/2 inches, straight key.....	A. S. T.	IV	9
		180	180	by 1/2 by 1 1/2 inches, straight key.....	A. S. T.		
		240	240	by 1/2 by 1 1/2 inches, round nose key.....	A. S. T.		
		150	150	by 1/2 by 3 inches, special.....	A. S. T.		
		900	900	by 1/2 inch, button head.....	A. S. T.		
		300	300	by 1/2 inch, button head.....	A. S. T.		
		900	900	by 1 1/2 inches, button head.....	A. S. T.		
		900	900	by 1 inch, button head.....	A. S. T.		
		900	900	by 1 1/2 inches, button head.....	A. S. T.		
		300	300	by 2 inches, button head.....	A. S. T.		
		300	300	by 1 1/2 inches, button head.....	A. S. T.		
		150	150	by 2 inches, button head.....	A. S. T.		
		900	900	by 1 1/2 inches, button head.....	A. S. T.		
		750	750	by 2 1/2 inches, button head.....	A. S. T.		
		150	150	by 1 inch, button head.....	A. S. T.		
		240	240	by 1/2 inch, flat head rivet.....	A. S. T.		
		15,000	15,000	by 1/2 inch, tubular.....	A. S. T.		
		2,400	2,400	by 1/2 inch, split rivet.....	A. S. T.		
		150	150	by 1 1/2 inches, wagon box.....	A. S. T.		
Drain cocks:							
		30	30	1-inch.....	A. S. T.		
		30	30	1-inch.....	A. S. T.		
		30	30	1-inch.....	A. S. T.		
Grease cups and oilers:							
		60	60	Bowen grease cup No. .000.....	A. S. T.		
		30	30	Winkley grease cup No. .000.....	A. S. T.		
		150	150	Winkley grease cup No. .00.....	A. S. T.		
Lock washers:							
		1,500	1,500	1/2-inch, S. A. E., light.....	A. S. T.		
		1,500	1,500	1/2-inch, S. A. E., light.....	A. S. T.		
		1,500	1,500	1/2-inch, S. A. E., heavy.....	A. S. T.		
		6,000	6,000	1/2-inch, S. A. E., heavy.....	A. S. T.		
		7,500	7,500	1/2-inch, S. A. E.....	A. S. T.		
		7,500	7,500	1/2-inch, S. A. E.....	A. S. T.		
		6,000	6,000	1/2-inch, S. A. E.....	A. S. T.		
		3,000	3,000	1/2-inch, S. A. E.....	A. S. T.		
		1,500	1,500	1/2-inch, S. A. E.....	A. S. T.		
		1,500	1,500	1/2-inch, S. A. E.....	A. S. T.		
		150	150	1/2 by 1 1/2 by 1/2 inch lock washer.....	A. S. T.		
		150	150	1/2 by 2 1/2 by 1/2 inch lock washer.....	A. S. T.		
Washers:							
		120	120	1/2 by 1/2 inch, No. 18.....	A. S. T.		
		120	120	1/2 by 1 1/2 by 1/2 inch.....	A. S. T.		
		120	120	1/2 by 1 1/2 by 1/2 inch.....	A. S. T.		
		120	120	1/2 by 1 1/2 inch, No. 13.....	A. S. T.		
		240	240	1/2 by 1 1/2 by 1/2 inch.....	A. S. T.		
		60	60	1 1/2 by 2 1/2 inch, No. 28.....	A. S. T.		
		120	120	1/2 by 1/2 inch, No. 16-18.....	A. S. T.		
		120	120	1/2 by 1 inch, No. 16-18.....	A. S. T.		
		60	60	1/2 by 1 1/2 inch, No. 16-18.....	A. S. T.		
		120	120	1/2 by 1 1/2 inch, No. 16-18.....	A. S. T.		
		120	120	1/2 by 1 inch, No. 14-16.....	A. S. T.		
		120	120	1/2 by 1 1/2 inch, No. 14-16.....	A. S. T.		
Felt washers:							
		240	240	2 1/2 by 2 1/2 by 1/2 inch, felt.....	A. S. T.		
		120	120	1/2 by 1 1/2 by 1/2 inch, felt.....	A. S. T.		
Pipe plugs:							
		120	120	1/2-inch.....	A. S. T.		
		60	60	1/2-inch.....	A. S. T.		
		60	60	1/2-inch.....	A. S. T.		
		120	120	1/2-inch.....	A. S. T.		
		30	30	1/2-inch.....	A. S. T.		
		30	30	1/2-inch.....	A. S. T.		
Pintle parts:							
		6	6	Pintle towing hook.....	A. S. T.		
		36	36	Pintle hook latch.....	A. S. T.		
		36	36	Pintle hook latch spring.....	A. S. T.		

Equipment for units composing a regiment of 155-mm. howitzer matériel, model of 1918  
(Schneider) motorized, on war footing—Continued.

Number per organization.				Article.	Where carried.	Property classification.			
B.	H. C.	S. C.	R.			Class.	Division.		
				<b>Loads carried by artillery supply trucks—</b>					
				<b>Continued.</b>					
				LOAD "B-1"—continued.					
				Pintle parts—Continued.					
		6	6	Pintle hook nut.....	A. S. T.	}			
		12	12	Pintle spring guide.....	A. S. T.				
		6	6	Pintle spring.....	A. S. T.				
		36	36	Pintle split pin.....	A. S. T.				
		36	36	Pintle latch pin.....	A. S. T.				
				Spare parts for lighting equipment:					
		18	18	Glass for side light.....	A. S. T.				
		36	36	Oil side light wick.....	A. S. T.				
		12	12	Red glass for tail lamp.....	A. S. T.				
				Spare tools and accessories:					
		6	6	Extinguisher, fire, complete, with bracket, "Fyr-Fyter," "Pyrene," or equal.....	A. S. T.				
		9	9	Liquid, Pyrene, in quart cans.....	A. S. T.				
		12	12	Straps, 12 inches long, style AV, 7 holes.....	A. S. T.				
		12	12	Straps, 15 inches long, style AV, 7 holes.....	A. S. T.				
		6	6	Straps, 22.75 inches long, style AV, 7 holes.....	A. S. T.				
		6	6	Straps, 15 inches long, style AVS, 7 holes.....	A. S. T.				
		12	12	Straps, lantern.....	A. S. T.				
		6	6	Straps, 34 inches long, style DV, 8 holes.....	A. S. T.				
		12	12	Straps, 52 inches long, style DV, 10 holes.....	A. S. T.				
				<b>Additional load carried when the regiment</b>					
				<b>is equipped with trucks having 2-ton</b>					
				<b>Nash chassis, model 4017-A only.</b>					
		12	12	Magneto, Eisemann, type 44, second edition, clockwise.....	A. S. T.	}	9		
		12	12	Ignition wire (cylinder No. 1).....	A. S. T.				
		24	24	Ignition wire (cylinders No. 2 and No. 4).....	A. S. T.				
		12	12	Ignition wire (cylinder No. 3).....	A. S. T.				
		12	12	Radiator brace rod, end (rear).....	A. S. T.				
		9	9	Spline shaft third speed drive gear.....	A. S. T.				
		6	6	Spline shaft sliding gear.....	A. S. T.				
		24	24	Spline shaft third speed gear washer (front).....	A. S. T.				
		6	6	Drive sprocket gear, type I, with sprocket 35419, type II.....	A. S. T.				
		18	18	Drive sprocket gear dowel bushings used with type I sprocket and gear only.....	A. S. T.				
		72	72	Drive sprocket gear screw, used with type I sprocket and gear only.....	A. S. T.				
		24	24	Spline shaft third speed gear washer (rear).....	A. S. T.				
		12	12	Spline shaft ball bearing (front and rear).....	A. S. T.				
		12	12	Shifter lock ball spring.....	A. S. T.				
		48	48	Shifter lock ball spring follower.....	A. S. T.				
		6	6	Shifter rod (first and second speed).....	A. S. T.				
		6	6	Shifter rod (third and fourth speed).....	A. S. T.				
		12	12	Shifter rod (reverse).....	A. S. T.				
		6	6	Axle drive shaft (right front).....	A. S. T.				
		6	6	Axle drive shaft (left front).....	A. S. T.				
		6	6	Axle drive shaft (right rear).....	A. S. T.				
		6	6	Axle drive shaft (left rear).....	A. S. T.				
		24	24	Differential gear (center).....	A. S. T.				
		36	36	Differential equalizing gear.....	A. S. T.				
		12	12	Differential spider.....	A. S. T.				
		6	6	Pinion sleeve nut.....	A. S. T.				
		6	6	Steering knuckle arm (rear left).....	A. S. T.				
		6	6	Steering knuckle arm (rear right).....	A. S. T.				
		12	12	Knuckle universal joint.....	A. S. T.				
		36	36	Searchlight door glass.....	A. S. T.				
		12	12	Universal joint cover (inner).....	A. S. T.				
		12	12	Universal joint cover (outer).....	A. S. T.				
		6	6	Wheel odometer and hub cap.....	A. S. T.				
		12	12	Wheel bearing, Timken, inner.....	A. S. T.				
		12	12	Tail lamp.....	A. S. T.				

Equipment for units composing a regiment of 155-mm. howitzer matériel, model of 1918 (Schneider) motorized, on war footing—Continued.

Number per organization.				Article.	Where carried.	Property classification.	
B.	H. C.	S. C.	R.			Class.	Division.
				<b>Additional load carried when the regiment is equipped with trucks having 2-ton Nash chassis, model 4017-L only.</b>			
		12	12	Magneto, Eisemann, type G4, second edition, clockwise, with impulse starter.	A. S. T.		
		12	12	Ignition wire with terminal (cylinder No. 1)	A. S. T.		
		24	24	Ignition wire with terminal (cylinders No. 2 and No. 4).	A. S. T.		
		12	12	Ignition wire with terminal (cylinder No. 3)	A. S. T.		
		3	3	Radiator rod end (rear)	A. S. T.		
		3	3	Spline shaft third speed drive gear	A. S. T.		
		3	3	Spline shaft sliding gear	A. S. T.		
		6	6	Axle drive shaft (right front)	A. S. T.		
		6	6	Axle drive shaft (right rear)	A. S. T.		
		6	6	Axle drive shaft (left front)	A. S. T.		
		6	6	Axle drive shaft (left rear)	A. S. T.		
		24	24	Differential gear (center)	A. S. T.		
		36	36	Differential equalizing gear	A. S. T.		
		12	12	Differential spider	A. S. T.		
		3	3	Pinion sleeve nut	A. S. T.		
		6	6	Pinion sleeve nut, Dune assembly	A. S. T.		
		6	6	Steering knuckle arm (rear left)	A. S. T.		
		6	6	Steering knuckle arm (rear right)	A. S. T.		
		12	12	Knuckle universal joint	A. S. T.		
		12	12	Universal joint cover (inner)	A. S. T.		
		12	12	Universal joint cover (outer)	A. S. T.		
		6	6	Wheel odometer and hub cap	A. S. T.		
		12	12	Wheel bearing, Timken, inner	A. S. T.		
		36	36	Gas searchlight door glass	A. S. T.		
		18	18	Oil tail light wick	A. S. T.		
		72	72	Gas tube, rubber	A. S. T.		
		72	72	Gas generator, terminal tube, rubber	A. S. T.		
				<b>Additional load carried when the regiment is equipped with trucks having 2-ton Nash chassis, model 4017-F only.</b>			
		12	12	Magneto, Eisemann, type G4, second edition, clockwise, with impulse starter.	A. S. T.		
		12	12	Ignition wire with terminal (cylinder No. 1)	A. S. T.		
		24	24	Ignition wire with terminal (cylinders Nos. 2 and 4).	A. S. T.		
		12	12	Ignition wire with terminal (cylinder No. 3)	A. S. T.		
		3	3	Spline shaft third speed drive gear	A. S. T.		
		3	3	Spline shaft sliding gear	A. S. T.		
		3	3	Spline shaft third speed gear washer (front)	A. S. T.		
		24	24	Spline shaft third speed gear washer (rear)	A. S. T.		
		12	12	Spline shaft ball bearing (front and rear)	A. S. T.		
		12	12	Shifter lock ball spring	A. S. T.		
		48	48	Shifter lock ball spring follower	A. S. T.		
		6	6	Shifter rod (first and second speed)	A. S. T.		
		6	6	Shifter rod (third and fourth speed)	A. S. T.		
		12	12	Shifter rod reverse	A. S. T.		
		3	3	Radiator brace rod end (rear)	A. S. T.		
		6	6	Axle drive shaft (right front)	A. S. T.		
		6	6	Axle drive shaft (left front)	A. S. T.		
		6	6	Axle drive shaft (right rear)	A. S. T.		
		6	6	Axle drive shaft (left rear)	A. S. T.		
		6	6	Steering knuckle arm, complete, right front	A. S. T.		
		6	6	Steering knuckle arm, complete, left	A. S. T.		
		6	6	Pinion sleeve nut, Dune assembly	A. S. T.		
		3	3	Pinion sleeve nut	A. S. T.		
		12	12	Wheel universal joint	A. S. T.		
		12	12	Universal joint cover (inner)	A. S. T.		
		12	12	Universal joint cover (outer)	A. S. T.		
		6	6	Wheel bearing, Timken, inner	A. S. T.		
		36	36	Gas searchlight door glass	A. S. T.		
		18	18	Oil tail light wick	A. S. T.		
		72	72	Gas tube, rubber	A. S. T.		
		72	72	Gas generator, terminal tube, rubber	A. S. T.		

IV

9

Equipment for units composing a regiment of 155-mm. howitzer matériel, model of 1918  
(Schneider) motorized, on war footing—Continued.

Number per organization.				Article.	Where carried.	Property classification.	
B.	H. C.	S. C.	R.			Class.	Division.
				<b>Additional load carried when the regiment is equipped with trucks having 2-ton Nash chassis, model 4017-F only—Con.</b>			
				<b>LOAD "C."</b>			
				(Carried by artillery supply trucks assigned to headquarters company.)			
.....	1	.....	1	Chest, "Spring".....	A. S. T.....	} IV	9
.....	2	.....	2	Chest, supply.....	A. S. T.....		
.....	1	.....	1	Chest, optical repair equipment.....	B. G.....		
.....	1	.....	1	Chest, optical instruments spare parts.....	B. G.....		
.....	1	.....	1	Chest, carpenter's, with contents as listed under load "A.".....	B. G.....		
				<b>LOAD "D."</b>			
				(Carried by artillery supply trucks assigned to and accompanying artillery repair trucks.)			
.....		3	3	Acid, muriatic (18° to 20° acidity), pounds.....	A. S. T.....	} X	10
.....		6	6	Bucket, water, galvanized steel.....	A. S. T.....		
.....		3	3	Bag for forge coal.....	A. S. T.....	} IV	9
.....		6	6	Bolts, model 1917.....	A. S. T.....		
.....		3	3	Bottle for acid, 16-ounce.....	A. S. T.....		
.....	90	90	90	Buckles, roller, 1.25-inch, bronze.....	A. S. T.....		
.....	3	3	3	Box, wooden, labeled "Acid".....	A. S. T.....		
.....		3	3	Bar, bronze, for bushings, "Nongran," assortment No. 8-54.....	A. S. T.....	} X	10
.....		6	6	Burner, lantern.....	A. S. T.....		
.....		3	3	Crowbar, 60-inch.....	A. S. T.....	} IV	9
.....	150	150	150	Coal, blacksmith's, pounds.....	A. S. T.....		
.....	45	45	45	Calcium carbide, 2-pound cans.....	A. S. T.....	} X	10
.....	75	75	75	Cable, high-tension, Packard S. A. E., ignition, feet.....	A. S. T.....		
.....		3	3	Cloth, crocus, quire.....	A. S. T.....	} X	10
.....		6	6	Cloth, emery, No. 1, quires.....	A. S. T.....		
.....		6	6	Cloth, emery, No. 00, quires.....	A. S. T.....		
.....	36	36	36	Clamps, cooper, adjustable.....	A. S. T.....		
.....		3	3	Carburetor, complete, Stromberg model M-2, 1½-inch, for Nash.....	A. S. T.....		
.....		3	3	Chest, grindstone.....	B. C.....	} IV	9
.....		6	6	Chest, miscellaneous.....	B. C.....		
.....		3	3	Chest, spring.....	A. S. T.....		
.....		3	3	Chest, supply.....	A. S. T.....		
.....		3	3	Chest for bolts and rivets.....	A. S. T.....		
				Each containing—			
				Bolts, machine, square head with square nuts:			
				50, ½ by 1½ inches.....	B. & R. C.....		
				50, ½ by 2 inches.....	B. & R. C.....		
				25, ½ by 1½ inches.....	B. & R. C.....		
				25, ½ by 2 inches.....	B. & R. C.....		
				25, ½ by 3 inches.....	B. & R. C.....		
				25, ½ by 3 inches.....	B. & R. C.....		
				25, ½ by 2 inches.....	B. & R. C.....		
				25, ½ by 4 inches.....	B. & R. C.....		
				Bolts, stove, with nuts (round head):			
				100, ¼ by 1 inch.....	B. & R. C.....	} X	10
				100, ¼ by 1½ inches.....	B. & R. C.....		
				100, ¼ by 1 inch.....	B. & R. C.....		
				100, ¼ by 1½ inches.....	B. & R. C.....		
				Rivets, brass, button head:			
				2, ½ by 1 inch, pounds.....	B. & R. C.....		
				Rivets, countersunk, 60° head:			
				5, ½ by 1 inch, pounds.....	B. & R. C.....		
				5, ½ by 2½ inches, pounds.....	B. & R. C.....		
				5, ½ by 3 inches, pounds.....	B. & R. C.....		
				5, ½ by 2½ inches, pounds.....	B. & R. C.....		

Equipment for units composing a regiment of 155-mm. howitzer matériel, model of 1918  
(Schneider) motorized, on war footing—Continued.

Number per organization.				Article.	Where carried.	Property classification.	
B.	H. C.	S. C.	R.			Class.	Division.
				<b>Loads carried by artillery supply trucks—</b>			
				<b>Continued.</b>			
				<b>LOAD "B-1"—continued.</b>			
		48	48	Breaker rocker arm (platinum contact)	A. S. T.		
		6	6	Breaker timing lever complete with cams	A. S. T.		
		24	24	Breaker end cap with short circuit brush	A. S. T.		
		3	3	Distributor plate, complete	A. S. T.		
		48	48	Distributor plate collector carbon brush	A. S. T.		
		120	120	Distributor carbon brush with spring	A. S. T.		
		96	96	Spark plug (Titan, $\frac{1}{4}$ -inch)	A. S. T.		
		96	96	Spark plug gasket	A. S. T.		
		12	12	Carburetor, complete (Stromberg M-2)	A. S. T.		
		12	12	Float	A. S. T.		
		12	12	High-speed needle valve	A. S. T.		
		12	12	Needle valve	A. S. T.		
		24	24	Strainer	A. S. T.		
		12	12	Strainer body	A. S. T.		
		24	24	Strainer body drain plug	A. S. T.		
		12	12	Strainer body stud	A. S. T.		
		12	12	Throttle stop set screw	A. S. T.		
		12	12	Throttle valve screw	A. S. T.		
		48	48	Carburetor gasket	A. S. T.		
		12	12	Fan blade and hub	A. S. T.		
		24	24	Fan shaft ball bearing	A. S. T.		
		72	72	Fan belt	A. S. T.		
		12	12	Governor flange gasket (upper)	A. S. T.		
		12	12	Governor flange gasket (lower)	A. S. T.		
		36	36	Radiator tank gasket	A. S. T.		
		3	3	Radiator core, complete	A. S. T.		
		24	24	Radiator inlet hose	A. S. T.		
		36	36	Radiator outlet hose	A. S. T.		
		12	12	Radiator brace rod (forked)	A. S. T.		
		12	12	Radiator brace rod end (front)	A. S. T.		
		30	30	Auxiliary tank to gasoline tank tube	A. S. T.		
		24	24	Gasoline tank cock	A. S. T.		
		12	12	Gasoline tank filler cap	A. S. T.		
		12	12	Gasoline strainer, complete	A. S. T.		
		12	12	Clutch drive plate (4-spline)	A. S. T.		
		72	72	Clutch facing	A. S. T.		
		12	12	Clutch lever operating collar bearing	A. S. T.		
		6	6	Clutch spring	A. S. T.		
		12	12	Clutch throwout sleeve thrust bearing	A. S. T.		
		48	48	Clutch brake lining	A. S. T.		
		3	3	Chain (62 links)	A. S. T.		
		12	12	Layshaft drive gear	A. S. T.		
		3	3	Layshaft third-speed drive gear	A. S. T.		
		3	3	Layshaft first-speed slide gear	A. S. T.		
		3	3	Layshaft second-speed slide gear	A. S. T.		
		3	3	Reverse gear	A. S. T.		
		3	3	Reverse rocker tube, complete	A. S. T.		
		6	6	Spline shaft drive sprocket, type II with gear 3015511 and screws	A. S. T.		
		12	12	Drive sprocket gear type II, used with sprocket 35419, type II	A. S. T.		
		36	36	Drive sprocket screw gear, used with type II sprocket and gear only	A. S. T.		
		12	12	Differential case bearing cone and rollers	A. S. T.		
		6	6	Differential bear assembly, with housing, complete, front and rear	A. S. T.		
		6	6	Pinion interbearing cone and rollers	A. S. T.		
		6	6	Pinion shaft sleeve and bearing cup	A. S. T.		
		6	6	Pinion shaft outer bearing cone and rollers	A. S. T.		
		6	6	Steering knuckle arm, complete (front left)	A. S. T.		
		6	6	Steering knuckle arm, complete (front right)	A. S. T.		
		72	72	Spring rebound clip (fifth leaf, rear)	A. S. T.		
		12	12	Spring shackle	A. S. T.		
		12	12	Spring plate (upper)	A. S. T.		
		72	72	Spring shackle bolt	A. S. T.		
		192	192	Spring clip bolt	A. S. T.		
		48	48	Front and rear spring rear hanger bushing	A. S. T.		
		96	96	Steering knuckle felt	A. S. T.		
		24	24	Steering knuckle pin bearing cone	A. S. T.		
		24	24	Steering knuckle pin bearing and retainer	A. S. T.		

IV

9

Equipment for units composing a regiment of 155-mm. howitzer matériel, model of 1918 (Schneider) motorized, on war footing—Continued.

Number per organization.				Article.	Where carried.	Property classification.	
B.	H. C.	S. C.	R.			Class.	Division.
				<b>Additional load carried when the regiment is equipped with trucks having 2-ton Nash chassis, model 4017-F only—Con.</b>			
				<b>LOAD "D"—continued.</b>			
				<b>Chest, fluid "D"—Continued.</b>			
				1/2 pint, standard, O. D., gallons	F. C.	X	10
				1/2 pint, special quick drying, O. D., gallons	F. C.		
				1 sal-ammoniac, lump, pounds	F. C.		
				5 sal soda, pounds	F. C.		
				1 stamp, seal (in stencil box)	F. C.		
				1 stencil, Ordnance Department insignia	F. C.		
				24 turpentine, gallons	F. C.		
				5 tape, friction, 3/4-inch, 1/2-pound, rolls	F. C.		
				5 tape, rubber, 1/2-inch, 1/2-pound rolls	F. C.		
				3 Chest, forge	A. S. T.		
				Each containing—			
				1 anvil, 100 pounds	A. S. T.	X	9
				2 aprons, blacksmiths	A. S. T.		
				2 bags, canvas for nails	A. S. T.		
				1 chisel, hot iron	A. S. T.		
				1 chisel, cold 8-inch	F. G. C.		
				1 chisel, handled, for cold iron, 2-pound	F. G. C.		
				1 drill, ratchet, for square shank drills	F. G. C.		
				6 drills, flat, 0.25-inch, 0.375-inch, 0.5-inch (2 each)	F. G. C.		
				1 file, flat bastard, double cut, 12-inch	F. G. C.		
				1 flatter, 1.5-inch square face, 14-inch handle	F. G. C.		
				1 forge, portable, "Empire," complete, modified for Army use, with wrench	F. G. C.		
				1 hammer, riveting, 1 pound 2 ounces	F. G. C.		
				1 hammer, hand, 2-pound	F. G. C.		
				1 handle, file, aluminum	G. G. C.		
				1 hardie, 0.75 square shank, 1.25-inch bit	F. G. C.		
				1 oiler	F. G. C.		
				1 punch, fore and creaser, double headed	F. G. C.		
				1 punch, nail	F. G. C.		
				1 pritchel, 9-inch	F. G. C.		
				1 punch, round, 0.312-inch	F. G. C.		
				1 punch, round, 0.375-inch	F. G. C.		
				1 punch, square, 0.312-inch	F. G. C.		
				1 rake, fire	F. G. C.		
				1 rule, boxwood, 2-foot, 4-fold	F. G. C.		
				1 shovel, fire	F. G. C.		
				1 square	F. G. C.		
				1 screw plate, taps and dies (U. S. S.), with tap wrench, including chest (drawing 76-7-77)	F. G. C.		
				1 set, rivet, 0.625 inch	F. G. C.		
				1 set, rivet, 0.5 inch	F. G. C.		
				1 set, rivet, 0.375 inch	F. G. C.		
				1 set, rivet, 0.25 inch	F. G. C.		
				1 set, rivet, 0.187 inch (3/16-inch)	F. G. C.		
				1 tongs, horseshoer's, 12-inch	F. G. C.		
				1 tongs, 1/2-inch iron	F. G. C.		
				1 tongs, 3/4-inch iron	F. G. C.		
				1 wrench, screw, 12-inch	F. G. C.		
				3 Extractor, screw, "Ezy Cut," set	A. S. T.	IV	9
				6 Globes, lantern	A. S. T.		
				3 Grindstone with frame complete	A. S. T.		
				6 Handles, pickax	A. S. T.		
				6 Handles, ax	A. S. T.		
				6 Handles, long handle shovel	A. S. T.		
				9 Handles, short handle shovel	A. S. T.		
				12 Handles, hatchet	A. S. T.		
				6 Handles, pick mattock	A. S. T.		
				36 Metal, ball-bitt, pounds (for medium pressure and high speed, tin, 30 per cent; antimony, 20 per cent; lead, 50 per cent.)	A. S. T.		
				3 Magneto, Eisemann, G 4 (second edition, complete with impulse starter, clockwise)	A. S. T.	IV	9
				3 Measure, copper, 1 quart capacity, graduated in pints and liters	A. S. T.		
				72 Plug, spark, 1/2-inch, S. A. E., "Titan"	A. S. T.		
				3 Rope, manila, 1 inch diameter by 150 feet long	A. S. T.		

Equipment for units composing a regiment of 155-mm. howitzer matériel, model of 1918  
(Schneider) motorized, on war footing—Continued.

Number per organization.				Article.	Where carried.	Property classification.	
B.	H. C.	S. C.	R.			Class.	Division.
				<b>Additional load carried when the regiment is equipped with trucks having 2-ton Nash chassis, model 4017-F only—Con.</b>			
				LOAD "D"—continued.			
		3	3	Sledge, model 1907.....	A. S. T.	IV	9
		6	6	Scabbards, holo, model 1917.....	A. S. T.		
		3	3	Sandpaper, No. 23, quire.....	A. S. T.		
		3	3	Shellac, orange, 1 pint can.....	A. S. T.	X	10
		12	12	Strap, 34 inches long, style DV, 8 holes.....	A. S. T.		
		24	24	Strap, 52 inches long, style DV, 10 holes (these straps for holding the spring chest, forge chest and fluid chest in place).	A. S. T.	IV	9
		3	3	Box, bar stock, each containing: Elbows, malleable iron: 3, 1/2-inch standard I. P..... 3, 1/2-inch standard I. P..... 3, 1/2-inch standard I. P..... 3, 1/2-inch standard I. P..... Pipe, wrought iron: 1, 1/2-inch I. P. by 4 feet..... 1, 1/2-inch I. P. by 4 feet..... 1, 1/2-inch I. P. by 4 feet..... 1, 1/2-inch I. P. by 4 feet..... Rod, brass, round (half hard): 1, 1/2-inch by 4 feet..... 1, 1/2-inch by 4 feet..... 1, 1/2-inch by 4 feet..... 1, 1/2-inch by 4 feet..... Steel, cold rolled, hexagon: 1, 1/2-inch by 4 feet..... 1, 1/2-inch by 4 feet..... 1, 1 1/4 inches by 4 feet..... Steel, cold rolled, round: 2, 1/2-inch by 4 feet..... 2, 1/2-inch by 4 feet..... 2, 1/2-inch by 4 feet..... 1, 1/2-inch by 4 feet..... 1, 1/2-inch by 4 feet..... 1, 1/2-inch by 4 feet..... 1, 1/2-inch by 4 feet..... 1, 1 1/4 inches by 4 feet..... Steel, cold rolled, square: 1, 1/2-inch by 4 feet..... 1, 1/2-inch by 4 feet..... 1, 1/2-inch by 4 feet..... Steel, flange (sheared plates): 1, 1/2-inch by 2 by 4 feet..... 1, 1/2-inch by 2 by 4 feet..... 1, 1/2-inch by 2 by 4 feet..... 1, 1/2-inch by 2 by 4 feet..... 1, 1/2-inch by 2 by 4 feet..... Steel, forged, flat: 1, 1/2 by 1 inch by 4 feet..... 1, 1/2 by 1 1/4 inches by 4 feet..... 1, 1/2 by 1 1/4 inches by 4 feet..... 1, 1/2 by 2 inches by 4 feet..... 1, 1/2 by 2 1/4 inches by 4 feet..... 1, 1/2 by 1 1/4 inches by 4 feet..... 1, 1/2 by 2 1/4 inches by 4 feet..... 1, 1/2 by 2 inches by 4 feet..... 1, 1/2 by 3 inches by 4 feet..... Steel, forged, round: 1, 1/2-inch by 4 feet..... 1, 1/2-inch by 4 feet..... 1, 1/2-inch by 4 feet..... 1, 1/2-inch by 4 feet..... Steel, tool, flat, Armstrong special or equal: 1, 1/2 by 1/2 inch by 3 feet..... Steel, tool, round, Armstrong special or equal: 1, 1/2-inch by 3 feet..... 1, 1/2-inch by 3 feet.....			

Equipment for units composing a regiment of 155-mm. howitzer matériel, model of 1918 (Schneider) motorized, on war footing—Continued.

Number per organization.				Article	Where carried.	Property classification.	
B.	H. C.	S. C.	R.			Class.	Division.
				<b>Additional load carried when the regiment is equipped with trucks having 2-ton Nash chassis, model 4017-F only—Con.</b>			
				LOAD "D"—continued.			
				Steel, tool, square, Arm-trong special or equal:			
				1, 1/4 inch by 3 feet.....	B. S. B.....	X	10
				1, 1/2 inch by 3 feet.....	B. S. B.....		
				1, 3/4 inch by 3 feet.....	B. S. B.....		
				1, 1 inch by 3 feet.....	B. S. B.....		
				1, 1 1/4 inch by 3 feet.....	B. S. B.....		
		3	3	Wire, copper, No. 16, B. & S. gage, spool.....	A. S. T.....	IV	9
		3	3	Wire, soft steel, No. 16, B. & S. gage, spool.....	A. S. T.....		
		18	18	Wicks, lantern.....	A. S. T.....	X	10
		3	3	Wrench, adjustable spanner, 3 by 4 1/2 inches.....	A. S. T.....		
		78	75	Waste, white, cotton, pounds.....	A. S. T.....		
				<b>Body equipment for the artillery repair truck.</b>			
		3	3	Ax.....	A. R. T.....	X	10
		6	6	Buckets, canvas, water, complete.....	A. R. T.....		
		3	3	Cover, canvas, for body.....	A. R. T.....		
		3	3	Can, safety, 1-gallon.....	A. R. T.....		
		6	6	Hatchets.....	A. R. T.....		
		3	3	Lantern, complete.....	A. R. T.....		
		3	3	Oil, medium, gasoline engine, gallon.....	A. R. T.....		
		6	6	Pads, lantern bracket.....	A. R. T.....		
		3	3	Pickax.....	A. R. T.....		
		6	6	Shovel, short handle.....	A. R. T.....		
		6	6	Straps, lantern bracket.....	A. R. T.....		
		12	12	Strap, 12 inches long, style AV, 7 holes (2 for hatchet, 1 for pickax, 1 for ax).....	A. R. T.....	IV	9
		6	6	Straps, 15 inches long, style AV, 7 holes (2 for short handle shovels).....	A. R. T.....		
		3	3	Strap, 22.75 inches long, style AV, 7 holes (1 for water bucket).....	A. R. T.....		
		3	3	Stove, Sibley, complete.....	A. R. T.....		
				<b>Body attachments for the artillery repair truck.</b>			
		3	3	Cover, canvas, for drill press.....	A. R. T.....	IV	9
		3	3	Cover, canvas, for generator.....	A. R. T.....		
		3	3	Cover, grinder and emery wheel.....	A. R. T.....		
		3	3	Cover, lathe.....	A. R. T.....		
		3	3	Cylinder, oxygen, 200 cubic feet capacity (filled).....	A. R. T.....		
		3	3	Cylinder, acetylene, 200 cubic feet capacity (filled).....	A. R. T.....		
		3	3	Drill press, with 1/2-horsepower, 110-volt, direct-current motor, complete, sensitive, bench type, friction drive:			
		3	3	Block, V.....	A. R. T.....		
		3	3	Center, cup.....	A. R. T.....		
		3	3	Center, point.....	A. R. T.....		
		3	3	Grinder, bench, with 1/2-horsepower, 110-volt, direct-current motor, complete:			
		6	6	Guard, adjustable steel.....	A. R. T.....		
		3	3	Pot, water, detachable.....	A. R. T.....		
		3	3	Switch, electric operating.....	A. R. T.....		
		6	6	Wheels, Norton alundum, 10 by 1 inch, grain 46, grade 0.....	A. R. T.....		
		3	3	Generating unit, complete, 4-kilowatt, 110-volt, direct-current:			
				Spare parts—			
		12	12	Bearings, connecting rods, pairs.....	A. R. T.....		
		24	24	Brushes, armature.....	A. R. T.....		
		6	6	Gaskets, cylinder head.....	A. R. T.....		
		12	12	Rings, piston, 1/2-inch.....	A. R. T.....		
		6	6	Rings, piston, 1/4-inch.....	A. R. T.....		
		3	3	Tappet, valve.....	A. R. T.....		
		6	6	Valves.....	A. R. T.....		



Equipment for units composing a regiment of 155-mm. howitzer matériel, model of 1918  
(Schneider) motorized, on war footing—Continued.

Number per organization.				Article.	Where carried.	Property classification.	
B.	H. C.	S. C.	R.			Class.	Division.
				<b>Body attachments for the artillery repair truck—Continued.</b>			
		57	57	Washers, lock, $\frac{1}{4}$ -inch, 8 for oxyacetylene welding outfit, 3 for vise to drop side, 4 for pipe vise to bench top, 4 for drill press support.	A. R. T.....	IV	9
		21	21	Washers, lock, $\frac{1}{4}$ -inch, 4 for drill press to frame, 3 for vise to bench cabinet.	A. R. T.....		
				<b>Load carried by the artillery repair truck.</b>			
		3	3	Ammeter, No. 1002 Eveready, 0-35 ampere range.	A. R. T.....	X	9
		3	3	Attachment, milling and gear cutting, each, including—			
				1 bar, overhanging, with tall center.....	A. R. T.....		
				1 block, cutter, with shaft and cutter.....	A. R. T.....		
				1 column, vertical side.....	A. R. T.....		
				1 clamp, vertical side column.....	A. R. T.....		
				1 clamp, bar support.....	A. R. T.....		
				1 crank, vertical column.....	A. R. T.....		
				1 crank, dividing head.....	A. R. T.....		
				1 head, dividing.....	A. R. T.....		
				1 support, overhanging bar.....	A. R. T.....		
				1 vise, milling.....	A. R. T.....		
		3	3	Apparatus, oxyacetylene welding and cutting complete.	A. R. T.....		
				Each consisting of—		IV	9
				1 case, welding tool, each containing.....	A. R. T.....		
				1 book, instruction.....	W. T. C.....		
				11 brochures, special.....	W. T. C.....		
				1 burner, Bunson, acetylene.....	W. T. C.....		
				1 gloves, canvas, pair.....	W. T. C.....		
				3 goggles, pair.....	W. T. C.....		
				1 hose, standard, black, 25 feet.....	W. T. C.....		
				1 hose, standard, red, 25 feet.....	W. T. C.....		
				1 lighter, spark.....	W. T. C.....		
				6 lighters, renewal spark.....	W. T. C.....		
				1 regulator, acetylene, No. 3 gages, 30 to 400 pounds.....	W. T. C.....		
				1 regulator, oxygen, No. 3 gages, 400 to 3,000 pounds.....	W. T. C.....		
				10 tips, cutting, Nos. 1, 2, 3, 4, 5 (2 each).....	W. T. C.....		
				10 tips, welding, Nos. 6, 7, 8, 9, 10 (2 each).....	W. T. C.....		
				5 tips, welding, special, Nos. 0, 1, 2, 3, 4 (for light gage metal).	W. T. C.....		
				1 torch, cutting, No. 3000, 2-hose.....	W. T. C.....		
				1 torch, welding, No. 146, standard.....	W. T. C.....		
				1 torch, decarbonizing.....	W. T. C.....		
				1 wrench, regulator.....	W. T. C.....		
				2 wrenches, torch.....	W. T. C.....		
				1 wheel, torch guide.....	W. T. C.....		
		3	3	Case, welding supply.....	A. R. T.....		
				Each containing—		X	10
				1 flux, "Marvel," in can, pound.....	W. S. C.....		
				1 flux, "Peerless Aluminum," in can, pound.....	W. S. C.....		
				2 gloves, canvas, pair.....	W. S. C.....		
				1 powder, cast-iron sealing, in can, pound.....	W. S. C.....		
				9 rods, "Atlas," cast-iron welding, $\frac{1}{4}$ -inch, pounds.....	W. S. C.....		
				4 $\frac{1}{2}$ rods, "Atlas," cast-iron welding, $\frac{1}{4}$ -inch, pounds.....	W. S. C.....		
				2 $\frac{1}{2}$ rods, aluminum, welding, $\frac{1}{4}$ -inch, pounds.....	W. S. C.....		
				4 rods, "Gem," welding, malleable iron, $\frac{1}{4}$ -inch, pounds.....	W. S. C.....		
				5 $\frac{1}{2}$ rods, "Marvel," welding, bronze and brass, $\frac{1}{4}$ -inch, pounds.....	W. S. C.....		
				11 $\frac{1}{2}$ rods, nickel steel, $\frac{1}{4}$ -inch, pounds.....	W. S. C.....		
				1 rod, vanadium steel, $\frac{1}{4}$ inch, pound.....	W. S. C.....		
				6 $\frac{1}{2}$ rods, wrought iron and steel, $\frac{1}{4}$ -inch, pounds.....	W. S. C.....		
				6 $\frac{1}{2}$ rods, wrought iron and steel, $\frac{1}{4}$ -inch, pounds.....	W. S. C.....		
				5 $\frac{1}{2}$ rods, wrought iron and steel, $\frac{1}{4}$ -inch, pounds.....	W. S. C.....		
		6	6	Batteries, tungsten, Eveready, No. 793.....	A. R. T.....	IV	9

Equipment for units composing a regiment of 155-mm. howitzer matériel, model of 1918 (Schneider) motorized, on war footing—Continued.

Number per organization.				Article.	Where carried.	Property classification.	
B.	H. C.	S. C.	R.			Class.	Division.
				<b>Load carried by the artillery repair truck—Continued.</b>			
		36	36	Blades, hacksaw, 10-inch, 24 teeth, Atkins Saw Co., No. 310.	A. R. T.		
		36	36	Blades, hacksaw, 10-inch, 14 teeth, Atkins Saw Co., No. 320.	A. R. T.	X	9
		3	3	Block, drill, with clamps, set.	A. R. T.		
		3	3	Book, "American Machinists' Hand"	A. R. T.		
		3	3	Book, "Audel's Automobile Questions and Answers for Operators and Repairmen."	A. R. T.	X	11
		3	3	Book, "Automobile Repairing Made Easy."	A. R. T.		
		3	3	Box for funnel.	A. R. T.		
		3	3	Funnel, small special.	A. R. T.		
		3	3	Funnel, filtering, No. 2, Schyler.	A. R. T.		
		9	9	Rings, for No. 2 filtering funnel.	A. R. T.	IV	9
		3	3	Bulb, flashlight, mazda, 2.7 volt.	A. R. T.		
		60	60	Bulbs, carbon, 16 candlepower, 50 watt, 110 volts.	A. R. T.		
		3	3	Bushings, expansion, for taper mandrels, 1/4-inch to 1/2-inch, advancing by sixteenths, in wooden box, 23 in set.	A. R. T.		
		3	3	Calipers, lock-joint transfer, outside, 10-inch.	A. R. T.		
		3	3	Calipers, lock-joint transfer, inside, 10-inch.	A. R. T.		
		3	3	Calipers, hermaphrodite, 6-inch, firm joint with adjustable point.	A. R. T.		
		3	3	Calipers, spring, 6-inch outside.	A. R. T.		
		3	3	Calipers, spring, 6-inch inside.	A. R. T.		
		3	3	Calipers, spring, 3-inch outside.	A. R. T.		
		3	3	Calipers, spring, 3-inch inside.	A. R. T.		
		3	3	Calipers, 3-inch, pocket slide rule, English.	A. R. T.		
		3	3	Calipers, micrometer, inside, set (containing 10 rods and one 1/4-inch gage in leather case).	A. R. T.		
		3	3	Calipers, micrometer, outside, set (graduated 1/1000 of an inch, including one 1-inch, one 2-inch and one 3-inch micrometer with ratchet stop, one 1-inch, one 2-inch test gage and two adjustable wrenches, in leather case).	A. R. T.	X	9
		3	3	Calipers, micrometer, metric, 0 to 75 mm., set.	A. R. T.		
		6	6	Chisel, cold, 6-inch, 1/2-inch octagon steel.	A. R. T.		
		6	6	Chisel, cold, 6-inch, 1/2-inch octagon steel.	A. R. T.		
		6	6	Chisel, cold, 5-inch, 1/2-inch octagon steel.	A. R. T.		
		6	6	Chisel, cold, 8-inch, 1/2-inch octagon steel.	A. R. T.		
		3	3	Chuck, combination, screw geared, 3-jaw, rated size 6.	A. R. T.		
		6	6	Chuck, drill, No. 9, capacity 0 to 1/2-inch with No. 2 Morse taper shank.	A. R. T.		
		6	6	Clamps, "C" (Vulcan) 2 1/2 inch.	A. R. T.		
		6	6	Clamps, "C" (Vulcan) 4 1/2 inch.	A. R. T.		
		6	6	Clamps, "C" (Vulcan) 6 1/2 inch.	A. R. T.		
		6	6	Clamps, tool makers, 1 1/2 inch.	A. R. T.		
		6	6	Clamps, tool makers, 3 1/2 inch.	A. R. T.		
		3	3	Clippers, bolt, 18 inches long, 1/4-inch capacity.	A. R. T.		
		6	6	Compound, valve grinding "Duplex" in 7-ounce box.	A. R. T.		
		3	3	Copper, soldering, 1/2 pound, pointed pattern with handle.	A. R. T.	X	10
		3	3	Copper, soldering, 1 1/2 pounds, pointed pattern with handle.	A. R. T.		
		3	3	Compressor, air, with 1 1/2 horse power motor, complete.	A. R. T.		
		3	3	Cord, extension, complete.	A. R. T.		
		3	3	Countersink, 82°, round shank, 1/4-inch diameter.	A. R. T.	X	9
		3	3	Countersink, 82°, square shank, 1/4-inch diameter, No. 5 "Little Giant."	A. R. T.		
		3	3	Countersink, 90° angle, shank 1/4-inch diameter, body 1-inch diameter, 2 1/2 inches long.	A. R. T.		
		3	3	Cover, canvas, for "American Machinist's Handbook."	A. R. T.		
		3	3	Cover, canvas, for "Audel's Automobile Guide."	A. R. T.	IV	9
		3	3	Cover, canvas, for "Automobile Repairing Made Easy."	A. R. T.		
		3	3	Cutter, side milling 1-inch.	A. R. T.		
		3	3	Cutter, side milling 1/2-inch.	A. R. T.	X	9
		3	3	Cutter, side milling 1/4-inch.	A. R. T.		

Equipment for units composing a regiment of 155-mm. howitzer matériel, model of 1918 (Schneider) motorized, on war footing—Continued.

Number per organization.				Article.	Where carried.	Property classification.	
B.	H. C.	S. C.	R.			Class.	Division.
				<b>Load carried by the artillery repair truck—Continued.</b>			
		3	3	Cutter, side milling $\frac{1}{4}$ -inch.....	A. R. T.....		
		3	3	Cutter, side milling $\frac{1}{4}$ -inch.....	A. R. T.....		
		3	3	Cutter, milling, 45° angle $\frac{1}{2}$ by $2\frac{1}{2}$ by $\frac{1}{4}$ by 8 inches, right hand.....	A. R. T.....		
		3	3	Cutter, milling, 45° angle $\frac{1}{2}$ by $2\frac{1}{2}$ by $\frac{1}{4}$ inches, left hand.....	A. R. T.....		
		3	3	Cutter, milling, convex, carbon steel $\frac{1}{4}$ -inch.....	A. R. T.....		
		3	3	Cutter, milling, convex, carbon steel $\frac{1}{4}$ -inch.....	A. R. T.....		
		3	3	Cutter, milling, convex, carbon steel $\frac{1}{4}$ -inch.....	A. R. T.....		
		3	3	Cutter, milling, convex, carbon steel $\frac{1}{4}$ -inch.....	A. R. T.....		
		3	3	Cutter, milling, double angle 60°, $\frac{1}{2}$ by $2\frac{1}{2}$ inches by $\frac{1}{4}$ inch.....	A. R. T.....		
		3	3	Cutter, metallsplitting, $\frac{1}{4}$ by $2\frac{1}{2}$ by $\frac{1}{4}$ inches.....	A. R. T.....		
		3	3	Cutter, metallsplitting, $\frac{1}{4}$ by $2\frac{1}{2}$ by $\frac{1}{4}$ inches.....	A. R. T.....		
		3	3	Cutter, metallsplitting, $\frac{1}{4}$ by $2\frac{1}{2}$ by $\frac{1}{4}$ inches.....	A. R. T.....		
		3	3	Cutter, metallsplitting, $\frac{1}{4}$ by $2\frac{1}{2}$ by $\frac{1}{4}$ inches.....	A. R. T.....		
		3	3	Cutter, metallsplitting, $\frac{1}{4}$ by $2\frac{1}{2}$ by $\frac{1}{4}$ inches.....	A. R. T.....		
		39	39	Cutters, threading tool, single point (to cut U. S. standard thread, Nos. 6, 7, 8, 9, 10, 11, 12, 13, 14, 15, 16, 18, 20, and fit Armstrong tool holder No. 50).....	A. R. T.....		
		3	3	Cutter, circular glass, 3 to 32 inches, with graduated bar and locking device.....	A. R. T.....		
		3	3	Dividers, spring, 6-inch.....	A. R. T.....		
		3	3	Dividers, spring, 3-inch.....	A. R. T.....		
	111	111	111	Drills, taper shank, $\frac{1}{2}$ by 14 inches (sizes advancing by sixty-fourths, $\frac{1}{4}$ to 1 inch, advancing by sixteenths from $1\frac{1}{8}$ inches to $1\frac{1}{2}$ inches, inclusive, standard Morse taper).....	A. R. T.....		
		3	3	Cutter, metallsplitting, $\frac{1}{4}$ by $2\frac{1}{2}$ by $\frac{1}{4}$ inches.....	A. R. T.....		
		3	3	Drift, drill, No. 2 Morse taper.....	A. R. T.....		
	252	252	252	Drills, straight shank, carbon steel 14 sizes, 6 of each, $\frac{1}{16}$ to $\frac{1}{4}$ inch, advancing by sixty-fourths.....	A. R. T.....		
		63	63	7 sizes, $\frac{1}{16}$ of each, $\frac{1}{16}$ to $\frac{1}{8}$ inch, advancing by sixty-fourths.....	A. R. T.....		
		48	48	8 sizes, 2 of each, $\frac{1}{16}$ to $\frac{1}{2}$ inch, advancing by sixty-fourths.....	A. R. T.....		
		3	3	Drills and countersinks, $\frac{1}{4}$ -inch diameter drill, $\frac{1}{4}$ inch diameter of body, size No. 22.....	A. R. T.....	X	9
		6	6	Drill and countersink, $\frac{1}{4}$ and $\frac{1}{8}$ inch diameter drill, 0.302 diameter of body, size No. 23.....	A. R. T.....		
		3	3	Drill, portable, electric, type EE with 110-volt, direct current, motor complete.....	A. R. T.....		
		3	3	Die stock, A. S. M. E. standard, set. (this to include 13 sizes of taps, dies, and collets. Each set of taps to include taper, plug and bottom, all in hardwood case, sizes: No. 0-80, No. 1-72, No. 2-64, No. 3-56, No. 4-48, No. 5-44, No. 6-40, No. 7-36, No. 8-36, No. 9-32, No. 10-30, No. 12-28, No. 14-24).....	A. R. T.....		
		3	3	Drills, hand and breast, No. 5 $\frac{1}{2}$ B, with chuck capacity 0 to $\frac{1}{4}$ inch.....	A. R. T.....		
		3	3	Dressers, emery wheel, $\frac{1}{2}$ by 10 inches, "Diamond-Desmond Carbo.".....	A. R. T.....		
		3	3	Dogs, lathe clamp, 1 $\frac{1}{2}$ -inch capacity.....	A. R. T.....		
		3	3	Dogs, lathe clamp, 2 $\frac{1}{2}$ -inch capacity.....	A. R. T.....		
		6	6	Files, flat, bastard, double cut, 10-inch, "Nicholson.".....	A. R. T.....		
		9	9	Files, flat, bastard, double cut, 12-inch, "Nicholson.".....	A. R. T.....		
		3	3	Files, flat, bastard, double cut, 14-inch "Nicholson.".....	A. R. T.....		
		6	6	Files, flat, double cut, second cut, 10-inch, "Nicholson.".....	A. R. T.....		
		9	9	Files, flat, double cut, second cut, 12-inch, "Nicholson.".....	A. R. T.....		
		3	3	Files, half round, double cut, bastard, 10-inch, "Nicholson.".....	A. R. T.....		
		3	3	Files, half round, double cut, bastard, 12-inch, "Nicholson.".....	A. R. T.....		
		3	3	Files, half round, double cut, second cut, 6-inch, "Nicholson.".....	A. R. T.....		

*Equipment for units composing a regiment of 155-mm. howitzer matériel, model of 1918 (Schneider) motorized, on war footing—Continued.*

Number per organization.				Article.	Where carried.	Property classification.			
B.	H. C.	S. C.	R.			Class.	Division.		
				<b>Load carried by the artillery repair truck—Continued.</b>					
.....		3	3	Files, half round, double cut, second cut, 8-inch, "Nicholson."	A. R. T.....	}			
.....		3	3	Files, half round, double cut, second cut, 10-inch, "Nicholson."	A. R. T.....				
.....		3	3	Files, half round, double cut, second cut, 12-inch, "Nicholson."	A. R. T.....				
.....		3	3	Files, round, double cut, second cut, 6-inch, "Nicholson."	A. R. T.....				
.....		3	3	Files, round, double cut, second cut, 8-inch, "Nicholson."	A. R. T.....				
.....		3	3	Files, round, double cut, second cut, 10-inch, "Nicholson."	A. R. T.....				
.....		3	3	Files, round, double cut, second cut, 12-inch, "Nicholson."	A. R. T.....				
.....		6	6	Files, round, bastard, double cut, 12-inch, "Nicholson."	A. R. T.....				
.....		12	12	Files, mill, single cut, smooth, 6-inch, "Nicholson."	A. R. T.....				
.....		3	3	Files, mill, single cut, smooth, 8-inch, "Nicholson."	A. R. T.....				
.....		6	6	Files, mill, single cut, smooth, 10-inch, "Nicholson."	A. R. T.....				
.....		3	3	Files, mill, single cut, smooth, 12-inch, "Nicholson."	A. R. T.....				
.....		6	6	Files, mill, bastard, single cut, 8-inch, "Nicholson."	A. R. T.....			X	9
.....		6	6	Files, mill, bastard, single cut, 10-inch, "Nicholson."	A. R. T.....				
.....		6	6	Files, mill, bastard, single cut, 12-inch, "Nicholson."	A. R. T.....				
.....		3	3	Files, square, double cut, second cut, 6-inch, "Nicholson."	A. R. T.....				
.....		3	3	Files, square, double cut, second cut, 8-inch, "Nicholson."	A. R. T.....				
.....		3	3	Files, square, double cut, second cut, 10-inch, "Nicholson."	A. R. T.....				
.....		3	3	Files, square, double cut, second cut, 12-inch, "Nicholson."	A. R. T.....				
.....		6	6	Files, square, bastard, double cut, 12-inch, "Nicholson."	A. R. T.....				
.....		3	3	Files, square, bastard, double cut, 14-inch, "Nicholson."	A. R. T.....				
.....		12	12	Files, taper saw, single cut, 4-inch.....	A. R. T.....				
.....		6	6	Files, taper saw, single cut, 6-inch.....	A. R. T.....				
.....		6	6	Files, taper handsaw, single cut, second cut, 8-inch, $\frac{1}{4}$ -inch taper.	A. R. T.....				
.....		6	6	Files, 3-square, slim, double cut, second cut, 6-inch.	A. R. T.....				
.....		3	3	Flashlights, American Eveready, No. 1991, without rubber hood.	A. R. T.....				
.....		60	60	Fuzes, 5-ampere, union, 250-volt, No. 6171.....	A. R. T.....				
.....		60	60	Fuzes, 10-ampere, N. E. C. union, 250-volt, No. 1010.	A. R. T.....				
.....		120	120	Fuzes, 20-ampere, N. E. C. union, 250-volt, No. 1015.	A. R. T.....	X	10		
.....		60	60	Fuzes, 50-ampere, N. E. C. union, 250-volt, No. 1019.	A. R. T.....				
.....		3	3	Frames, hacksaw, adjustable.....	A. R. T.....				
.....		3	3	Gages, center.....	A. R. T.....				
.....		3	3	Gages, micrometer, depth, with 2 extra rods.....	A. R. T.....				
.....		3	3	Gages, screw-threading tool, 29".....	A. R. T.....				
.....		3	3	Gages, worm-thread.....	A. R. T.....				
.....		3	3	Gages, screw-pitch, V-thread.....	A. R. T.....				
.....		3	3	Gages, jobber's drill, $\frac{1}{4}$ to $\frac{1}{2}$ inch.....	A. R. T.....				
.....		3	3	Gages, thickness, 9 blades.....	A. R. T.....				
.....		3	3	Gages, universal surface, with 9-inch spindle, base not hardened.	A. R. T.....				
.....		3	3	Grinders, automobile valve.....	A. R. T.....	X		9	

Equipment for units composing a regiment of 155-mm. howitzer matériel, model of 1918 (Schneider) motorized, on war footing—Continued.

Number per organization.				Article.	Where carried.	Property classification.	
B.	H. C.	S. C.	R.			Class.	Division.
				<b>Load carried by the artillery repair truck—Continued.</b>			
		3	3	Grinders, tool post, type "P," with 1-horse-power, 110-volt, direct current-motor, complete, each including:	A. R. T.....	X	9
				1 cord, extension, 7 feet, with fuze plugs....	A. R. T.....		
				1 mandrel, extension, 4½ by ½ inches.....	A. R. T.....	X	10
				2 plugs, fuze (extra).....	A. R. T.....		
				1 rest, tooth.....	A. R. T.....		
				1 shank, ¾ by 1 by 4½ inches.....	A. R. T.....		
				1 wheel, Norton alundum, 1½ by ¾ inches, grain 3,860, grade N.	A. R. T.....		
				1 wheel, Norton alundum, 4½ by ¾ inches, grain 3,860, grade N.	A. R. T.....		
		3	3	Hammer, claw, bell face, size No. 11, 1 pound 3 ounces.	A. R. T.....		
		3	3	Hammer, machinist's, ball peen, No. 00, 17 ounces.	A. R. T.....		
		3	3	Hammer, machinist's, ball peen, octagon, No. 0, 1 pound.	A. R. T.....		
		3	3	Hammer, rounding, 2 pounds.....	A. R. T.....		
		3	3	Hammer, pneumatic, ¾ BK "Boyer".....	A. R. T.....		
		36	36	Chisels, chipping, sizes ¼, ½, ¾, 1 inch.....	A. R. T.....		
		3	3	Nipple, ¾ inch for 1-inch hose.....	A. R. T.....		
		18	18	Sets, rivet, buttonhead, sizes ¼, ½, ¾, 1, 1½, 2 inch.	A. R. T.....		
		3	3	Wrench, spanner.....	A. R. T.....		
		3	3	Holder, bar boring tool, "Agrippa," No. 80.....	A. R. T.....		
		3	3	Holder, cutting-off tool, No. 20R "Agrippa," ¾ by ½ inch.	A. R. T.....		
		3	3	Holder, cutting-off tool, No. 30R "Agrippa," ¾ by ½ inch.	A. R. T.....		
		3	3	Holder, cutting-off tool, No. 30L "Agrippa," ¾ by ½ inch.	A. R. T.....		
		3	3	Holder, side tool, No. 30R, "Agrippa," ¾ by ½ inch.	A. R. T.....		
		3	3	Holder, side tool, No. 30L, "Agrippa," ¾ by ½ inch.	A. R. T.....		
		3	3	Holder, threading tool, ¾ by ½ inch.....	A. R. T.....	X	9
		3	3	Holder, turning tool, "Agrippa" O-S, ¾ by ½ by 5 inches, straight shank, with 2 high-speed ¼-inch cutters.	A. R. T.....		
		3	3	Holder, turning tool, "Agrippa" O-R, ¾ by ½ by 5½ inches, right-hand, offset shank, with 2 high-speed ¼-inch cutters.	A. R. T.....		
		3	3	Holder, turning tool, "Agrippa" O-L, ¾ by ½ by 5½ inches, left-hand, offset shank, with 2 high-speed ¼-inch cutters.	A. R. T.....		
		3	3	Holder, drill, No. 2 Morse taper.....	A. R. T.....		
		3	3	Indicator, test.....	A. R. T.....		
		3	3	Ladle, melting, 1½-pint capacity.....	A. R. T.....		
		3	3	Lamp, floor, adjustable, with portable stand, complete.	A. R. T.....		
		21	21	Mandrels, taper, Nos. 3 to 9, inclusive (in wooden box).	A. R. T.....		
		24	24	Mills, end spiral, No. 1 Morse taper, right hand, 1, 1½, 2 inch; left hand, 1, 1½, 2 inch.	A. R. T.....		
		24	24	Mills, end spiral, No. 2 Morse taper, right-hand, 1, 1½, 2 inch; left-hand, 1, 1½, 2 inch.	A. R. T.....		
		6	6	Parallels, ¾ by 1 by 6 inches.....	A. R. T.....		
		6	6	Parallels, ¾ by 1 by 6 inches.....	A. R. T.....		
		3	3	Plate, automobile screw No. 1463, S. A. E. standard, set (each set to include hardwood case, stock 22 inches long, plug taps, dies, and guides, from ¼ to 1 inch, advancing by sixteenths).	A. R. T.....		
		3	3	Pliers, long round nose, 5½ inches.....	A. R. T.....		
		3	3	Pliers, curve nose, 5½ inches.....	A. R. T.....		
		9	9	Punches, machine center.....	A. R. T.....		
		3	3	Reamer, hand, "Alvord," set of 25, advancing by 32nds, ¼ by 1 inch.	A. R. T.....		

*Equipment for units composing a regiment of 155-mm. howitzer matériel, model of 1918 (Schneider) motorized, on war footing—Continued.*

Number per organization.				Article.	Where carried.	Property classification.	
B.	H. C.	S. C.	R.			Class.	Division.
				<b>Load carried by the artillery repair truck—Continued.</b>			
.....			3	Reamer, taper pin, "Alvord," 0 to 5, set.....	A. R. T.....		
.....			3	Rule, 3-inch, graduation No. 7.....	A. R. T.....		
.....			3	Rule, 6-inch, graduation No. 7.....	A. R. T.....		
.....			3	Rule, 6-inch, flexible, graduation No. 10.....	A. R. T.....		
.....			3	Rule, metric, folding, No. 1173M.....	A. R. T.....		
.....			3	Rule, 36-inch, English, graduation.....	A. R. T.....		
.....			3	Screw driver, 4-inch, Smith's Perfect Handle, No. 609.....	A. R. T.....		
.....		6	6	Screw driver, 6-inch, Smith's Perfect Handle, No. 609.....	A. R. T.....		
.....			3	Screw driver, 8-inch, Smith's Perfect Handle, No. 609.....	A. R. T.....		
.....		12	12	Scale, flexible, 300 mm. No. 2100M.....	A. R. T.....		
.....		12	12	Scale, semiflexible, 150 mm. No. 2600M.....	A. R. T.....		
.....			3	Scribers, improved, adjustable sleeve.....	A. R. T.....		
.....		6	6	Sleeves, collet, No. 1 Morse taper, inside, No. 2 Morse taper, outside.....	A. R. T.....		
.....			3	Snips, tinner, 10-inch, forged steel.....	A. R. T.....		
.....			3	Square, 3-inch try, solid steel.....	A. R. T.....		
.....			3	Square, 6-inch try, solid steel.....	A. R. T.....		
.....			3	Square, 4-inch, patent double (2 blades and stock).....	A. R. T.....		
.....			3	Square, 12-inch combination, set.....	A. R. T.....		
.....			3	Tank, compressed air, complete: 1 clamp, hose, adjustable.....	A. R. T.....		
.....				1 cock, drain, 1/4-inch brass.....	A. R. T.....		
.....				1 coupling, "Bowes," 1/4-inch hose, male half.....	A. R. T.....		
.....				1 coupling, "Bowes," 1/4-inch hose, female half.....	A. R. T.....		
.....				2 coupling, "Bowes," 1/4-inch hose, female end, outside 1/4-inch thread.....	A. R. T.....		
.....				1 gage, pressure, brass cast, with screwed-on ring dial, 200-pound capacity.....	A. R. T.....		
.....				2 hose, pneumatic, 1/2-inch, 5-ply, 25 feet long, armored, "Quarry," "Bowes," coupling each end.....	A. R. T.....		
.....				1 hose, pneumatic, 1/2-inch, 6 feet long, Goodrich 3 braid "Mainstay," "Bowes," 1/2-inch coupling on one end.....	A. R. T.....		
.....				1 hose, pneumatic, 1/2-inch, "Penflex" bronze, No. 2 metal, 10 feet long, with 1/2-inch union pipe coupling at each end.....	A. R. T.....		
.....				4 nipples, 1/4-inch I. P. by 2 inches.....	A. R. T.....		
.....				2 nipples, 1/4-inch I. P. by 4 inches.....	A. R. T.....		
.....				1 tee, 1/4-inch I. P. malleable iron.....	A. R. T.....		
.....				2 valves, 1/4-inch globe, brass body with soft disk for 150-pound pressure.....	A. R. T.....		
.....				1 valve, 1/4-inch consolidated, safety pop with soft disk to blow off at 150-pound pressure.....	A. R. T.....		
.....				1 valve, 1/4-inch, check, horizontal brass body, soft disk, 150-pound pressure.....	A. R. T.....		
.....		3	3	Tap and die, metric, set (stock sizes No. 6, No. 7, No. 10; tap wrenches No. 1, No. 2, No. 3; dies adjustable round split, sizes 2, 3, 4, 5, 6, 7, 8, 10, 12, 14, 16, 18, 20, 22, 24, and 26 mm., taper, plug and bottom taps).....	A. R. T.....		
.....			3	Taps, hand, U. S. taper, plug and bottom set (sizes 1/4, 1/2, 3/4, 1, 1 1/4, 1 1/2, 1 3/4, 2, 2 1/4, 2 3/4, 3, 3 1/4, 3 3/4, 4, 4 1/4, 4 3/4, 5, 5 1/4, 5 3/4, 6, 6 1/4, 6 3/4, 7, 7 1/4, 7 3/4, 8, 8 1/4, 8 3/4, 9, 9 1/4, 9 3/4, 10, 10 1/4, 10 3/4, 11, 11 1/4, 11 3/4, 12, 12 1/4, 12 3/4, 13, 13 1/4, 13 3/4, 14, 14 1/4, 14 3/4, 15, 15 1/4, 15 3/4, 16, 16 1/4, 16 3/4, 17, 17 1/4, 17 3/4, 18, 18 1/4, 18 3/4, 19, 19 1/4, 19 3/4, 20, 20 1/4, 20 3/4, 21, 21 1/4, 21 3/4, 22, 22 1/4, 22 3/4, 23, 23 1/4, 23 3/4, 24, 24 1/4, 24 3/4, 25, 25 1/4, 25 3/4, 26, 26 1/4, 26 3/4, 27, 27 1/4, 27 3/4, 28, 28 1/4, 28 3/4, 29, 29 1/4, 29 3/4, 30, 30 1/4, 30 3/4, 31, 31 1/4, 31 3/4, 32, 32 1/4, 32 3/4, 33, 33 1/4, 33 3/4, 34, 34 1/4, 34 3/4, 35, 35 1/4, 35 3/4, 36, 36 1/4, 36 3/4, 37, 37 1/4, 37 3/4, 38, 38 1/4, 38 3/4, 39, 39 1/4, 39 3/4, 40, 40 1/4, 40 3/4, 41, 41 1/4, 41 3/4, 42, 42 1/4, 42 3/4, 43, 43 1/4, 43 3/4, 44, 44 1/4, 44 3/4, 45, 45 1/4, 45 3/4, 46, 46 1/4, 46 3/4, 47, 47 1/4, 47 3/4, 48, 48 1/4, 48 3/4, 49, 49 1/4, 49 3/4, 50, 50 1/4, 50 3/4, 51, 51 1/4, 51 3/4, 52, 52 1/4, 52 3/4, 53, 53 1/4, 53 3/4, 54, 54 1/4, 54 3/4, 55, 55 1/4, 55 3/4, 56, 56 1/4, 56 3/4, 57, 57 1/4, 57 3/4, 58, 58 1/4, 58 3/4, 59, 59 1/4, 59 3/4, 60, 60 1/4, 60 3/4, 61, 61 1/4, 61 3/4, 62, 62 1/4, 62 3/4, 63, 63 1/4, 63 3/4, 64, 64 1/4, 64 3/4, 65, 65 1/4, 65 3/4, 66, 66 1/4, 66 3/4, 67, 67 1/4, 67 3/4, 68, 68 1/4, 68 3/4, 69, 69 1/4, 69 3/4, 70, 70 1/4, 70 3/4, 71, 71 1/4, 71 3/4, 72, 72 1/4, 72 3/4, 73, 73 1/4, 73 3/4, 74, 74 1/4, 74 3/4, 75, 75 1/4, 75 3/4, 76, 76 1/4, 76 3/4, 77, 77 1/4, 77 3/4, 78, 78 1/4, 78 3/4, 79, 79 1/4, 79 3/4, 80, 80 1/4, 80 3/4, 81, 81 1/4, 81 3/4, 82, 82 1/4, 82 3/4, 83, 83 1/4, 83 3/4, 84, 84 1/4, 84 3/4, 85, 85 1/4, 85 3/4, 86, 86 1/4, 86 3/4, 87, 87 1/4, 87 3/4, 88, 88 1/4, 88 3/4, 89, 89 1/4, 89 3/4, 90, 90 1/4, 90 3/4, 91, 91 1/4, 91 3/4, 92, 92 1/4, 92 3/4, 93, 93 1/4, 93 3/4, 94, 94 1/4, 94 3/4, 95, 95 1/4, 95 3/4, 96, 96 1/4, 96 3/4, 97, 97 1/4, 97 3/4, 98, 98 1/4, 98 3/4, 99, 99 1/4, 99 3/4, 100, 100 1/4, 100 3/4, 101, 101 1/4, 101 3/4, 102, 102 1/4, 102 3/4, 103, 103 1/4, 103 3/4, 104, 104 1/4, 104 3/4, 105, 105 1/4, 105 3/4, 106, 106 1/4, 106 3/4, 107, 107 1/4, 107 3/4, 108, 108 1/4, 108 3/4, 109, 109 1/4, 109 3/4, 110, 110 1/4, 110 3/4, 111, 111 1/4, 111 3/4, 112, 112 1/4, 112 3/4, 113, 113 1/4, 113 3/4, 114, 114 1/4, 114 3/4, 115, 115 1/4, 115 3/4, 116, 116 1/4, 116 3/4, 117, 117 1/4, 117 3/4, 118, 118 1/4, 118 3/4, 119, 119 1/4, 119 3/4, 120, 120 1/4, 120 3/4, 121, 121 1/4, 121 3/4, 122, 122 1/4, 122 3/4, 123, 123 1/4, 123 3/4, 124, 124 1/4, 124 3/4, 125, 125 1/4, 125 3/4, 126, 126 1/4, 126 3/4, 127, 127 1/4, 127 3/4, 128, 128 1/4, 128 3/4, 129, 129 1/4, 129 3/4, 130, 130 1/4, 130 3/4, 131, 131 1/4, 131 3/4, 132, 132 1/4, 132 3/4, 133, 133 1/4, 133 3/4, 134, 134 1/4, 134 3/4, 135, 135 1/4, 135 3/4, 136, 136 1/4, 136 3/4, 137, 137 1/4, 137 3/4, 138, 138 1/4, 138 3/4, 139, 139 1/4, 139 3/4, 140, 140 1/4, 140 3/4, 141, 141 1/4, 141 3/4, 142, 142 1/4, 142 3/4, 143, 143 1/4, 143 3/4, 144, 144 1/4, 144 3/4, 145, 145 1/4, 145 3/4, 146, 146 1/4, 146 3/4, 147, 147 1/4, 147 3/4, 148, 148 1/4, 148 3/4, 149, 149 1/4, 149 3/4, 150, 150 1/4, 150 3/4, 151, 151 1/4, 151 3/4, 152, 152 1/4, 152 3/4, 153, 153 1/4, 153 3/4, 154, 154 1/4, 154 3/4, 155, 155 1/4, 155 3/4, 156, 156 1/4, 156 3/4, 157, 157 1/4, 157 3/4, 158, 158 1/4, 158 3/4, 159, 159 1/4, 159 3/4, 160, 160 1/4, 160 3/4, 161, 161 1/4, 161 3/4, 162, 162 1/4, 162 3/4, 163, 163 1/4, 163 3/4, 164, 164 1/4, 164 3/4, 165, 165 1/4, 165 3/4, 166, 166 1/4, 166 3/4, 167, 167 1/4, 167 3/4, 168, 168 1/4, 168 3/4, 169, 169 1/4, 169 3/4, 170, 170 1/4, 170 3/4, 171, 171 1/4, 171 3/4, 172, 172 1/4, 172 3/4, 173, 173 1/4, 173 3/4, 174, 174 1/4, 174 3/4, 175, 175 1/4, 175 3/4, 176, 176 1/4, 176 3/4, 177, 177 1/4, 177 3/4, 178, 178 1/4, 178 3/4, 179, 179 1/4, 179 3/4, 180, 180 1/4, 180 3/4, 181, 181 1/4, 181 3/4, 182, 182 1/4, 182 3/4, 183, 183 1/4, 183 3/4, 184, 184 1/4, 184 3/4, 185, 185 1/4, 185 3/4, 186, 186 1/4, 186 3/4, 187, 187 1/4, 187 3/4, 188, 188 1/4, 188 3/4, 189, 189 1/4, 189 3/4, 190, 190 1/4, 190 3/4, 191, 191 1/4, 191 3/4, 192, 192 1/4, 192 3/4, 193, 193 1/4, 193 3/4, 194, 194 1/4, 194 3/4, 195, 195 1/4, 195 3/4, 196, 196 1/4, 196 3/4, 197, 197 1/4, 197 3/4, 198, 198 1/4, 198 3/4, 199, 199 1/4, 199 3/4, 200, 200 1/4, 200 3/4, 201, 201 1/4, 201 3/4, 202, 202 1/4, 202 3/4, 203, 203 1/4, 203 3/4, 204, 204 1/4, 204 3/4, 205, 205 1/4, 205 3/4, 206, 206 1/4, 206 3/4, 207, 207 1/4, 207 3/4, 208, 208 1/4, 208 3/4, 209, 209 1/4, 209 3/4, 210, 210 1/4, 210 3/4, 211, 211 1/4, 211 3/4, 212, 212 1/4, 212 3/4, 213, 213 1/4, 213 3/4, 214, 214 1/4, 214 3/4, 215, 215 1/4, 215 3/4, 216, 216 1/4, 216 3/4, 217, 217 1/4, 217 3/4, 218, 218 1/4, 218 3/4, 219, 219 1/4, 219 3/4, 220, 220 1/4, 220 3/4, 221, 221 1/4, 221 3/4, 222, 222 1/4, 222 3/4, 223, 223 1/4, 223 3/4, 224, 224 1/4, 224 3/4, 225, 225 1/4, 225 3/4, 226, 226 1/4, 226 3/4, 227, 227 1/4, 227 3/4, 228, 228 1/4, 228 3/4, 229, 229 1/4, 229 3/4, 230, 230 1/4, 230 3/4, 231, 231 1/4, 231 3/4, 232, 232 1/4, 232 3/4, 233, 233 1/4, 233 3/4, 234, 234 1/4, 234 3/4, 235, 235 1/4, 235 3/4, 236, 236 1/4, 236 3/4, 237, 237 1/4, 237 3/4, 238, 238 1/4, 238 3/4, 239, 239 1/4, 239 3/4, 240, 240 1/4, 240 3/4, 241, 241 1/4, 241 3/4, 242, 242 1/4, 242 3/4, 243, 243 1/4, 243 3/4, 244, 244 1/4, 244 3/4, 245, 245 1/4, 245 3/4, 246, 246 1/4, 246 3/4, 247, 247 1/4, 247 3/4, 248, 248 1/4, 248 3/4, 249, 249 1/4, 249 3/4, 250, 250 1/4, 250 3/4, 251, 251 1/4, 251 3/4, 252, 252 1/4, 252 3/4, 253, 253 1/4, 253 3/4, 254, 254 1/4, 254 3/4, 255, 255 1/4, 255 3/4, 256, 256 1/4, 256 3/4, 257, 257 1/4, 257 3/4, 258, 258 1/4, 258 3/4, 259, 259 1/4, 259 3/4, 260, 260 1/4, 260 3/4, 261, 261 1/4, 261 3/4, 262, 262 1/4, 262 3/4, 263, 263 1/4, 263 3/4, 264, 264 1/4, 264 3/4, 265, 265 1/4, 265 3/4, 266, 266 1/4, 266 3/4, 267, 267 1/4, 267 3/4, 268, 268 1/4, 268 3/4, 269, 269 1/4, 269 3/4, 270, 270 1/4, 270 3/4, 271, 271 1/4, 271 3/4, 272, 272 1/4, 272 3/4, 273, 273 1/4, 273 3/4, 274, 274 1/4, 274 3/4, 275, 275 1/4, 275 3/4, 276, 276 1/4, 276 3/4, 277, 277 1/4, 277 3/4, 278, 278 1/4, 278 3/4, 279, 279 1/4, 279 3/4, 280, 280 1/4, 280 3/4, 281, 281 1/4, 281 3/4, 282, 282 1/4, 282 3/4, 283, 283 1/4, 283 3/4, 284, 284 1/4, 284 3/4, 285, 285 1/4, 285 3/4, 286, 286 1/4, 286 3/4, 287, 287 1/4, 287 3/4, 288, 288 1/4, 288 3/4, 289, 289 1/4, 289 3/4, 290, 290 1/4, 290 3/4, 291, 291 1/4, 291 3/4, 292, 292 1/4, 292 3/4, 293, 293 1/4, 293 3/4, 294, 294 1/4, 294 3/4, 295, 295 1/4, 295 3/4, 296, 296 1/4, 296 3/4, 297, 297 1/4, 297 3/4, 298, 298 1/4, 298 3/4, 299, 299 1/4, 299 3/4, 300, 300 1/4, 300 3/4, 301, 301 1/4, 301 3/4, 302, 302 1/4, 302 3/4, 303, 303 1/4, 303 3/4, 304, 304 1/4, 304 3/4, 305, 305 1/4, 305 3/4, 306, 306 1/4, 306 3/4, 307, 307 1/4, 307 3/4, 308, 308 1/4, 308 3/4, 309, 309 1/4, 309 3/4, 310, 310 1/4, 310 3/4, 311, 311 1/4, 311 3/4, 312, 312 1/4, 312 3/4, 313, 313 1/4, 313 3/4, 314, 314 1/4, 314 3/4, 315, 315 1/4, 315 3/4, 316, 316 1/4, 316 3/4, 317, 317 1/4, 317 3/4, 318, 318 1/4, 318 3/4, 319, 319 1/4, 319 3/4, 320, 320 1/4, 320 3/4, 321, 321 1/4, 321 3/4, 322, 322 1/4, 322 3/4, 323, 323 1/4, 323 3/4, 324, 324 1/4, 324 3/4, 325, 325 1/4, 325 3/4, 326, 326 1/4, 326 3/4, 327, 327 1/4, 327 3/4, 328, 328 1/4, 328 3/4, 329, 329 1/4, 329 3/4, 330, 330 1/4, 330 3/4, 331, 331 1/4, 331 3/4, 332, 332 1/4, 332 3/4, 333, 333 1/4, 333 3/4, 334, 334 1/4, 334 3/4, 335, 335 1/4, 335 3/4, 336, 336 1/4, 336 3/4, 337, 337 1/4, 337 3/4, 338, 338 1/4, 338 3/4, 339, 339 1/4, 339 3/4, 340, 340 1/4, 340 3/4, 341, 341 1/4, 341 3/4, 342, 342 1/4, 342 3/4, 343, 343 1/4, 343 3/4, 344, 344 1/4, 344 3/4, 345, 345 1/4, 345 3/4, 346, 346 1/4, 346 3/4, 347, 347 1/4, 347 3/4, 348, 348 1/4, 348 3/4, 349, 349 1/4, 349 3/4, 350, 350 1/4, 350 3/4, 351, 351 1/4, 351 3/4, 352, 352 1/4, 352 3/4, 353, 353 1/4, 353 3/4, 354, 354 1/4, 354 3/4, 355, 355 1/4, 355 3/4, 356, 356 1/4, 356 3/4, 357, 357 1/4, 357 3/4, 358, 358 1/4, 358 3/4, 359, 359 1/4, 359 3/4, 360, 360 1/4, 360 3/4, 361, 361 1/4, 361 3/4, 362, 362 1/4, 362 3/4, 363, 363 1/4, 363 3/4, 364, 364 1/4, 364 3/4, 365, 365 1/4, 365 3/4, 366, 366 1/4, 366 3/4, 367, 367 1/4, 367 3/4, 368, 368 1/4, 368 3/4, 369, 369 1/4, 369 3/4, 370, 370 1/4, 370 3/4, 371, 371 1/4, 371 3/4, 372, 372 1/4, 372 3/4, 373, 373 1/4, 373 3/4, 374, 374 1/4, 374 3/4, 375, 375 1/4, 375 3/4, 376, 376 1/4, 376 3/4, 377, 377 1/4, 377 3/4, 378, 378 1/4, 378 3/4, 379, 379 1/4, 379 3/4, 380, 380 1/4, 380 3/4, 381, 381 1/4, 381 3/4, 382, 382 1/4, 382 3/4, 383, 383 1/4, 383 3/4, 384, 384 1/4, 384 3/4, 385, 385 1/4, 385 3/4, 386, 386 1/4, 386 3/4, 387, 387 1/4, 387 3/4, 388, 388 1/4, 388 3/4, 389, 389 1/4, 389 3/4, 390, 390 1/4, 390 3/4, 391, 391 1/4, 391 3/4, 392, 392 1/4, 392 3/4, 393, 393 1/4, 393 3/4, 394, 394 1/4, 394 3/4, 395, 395 1/4, 395 3/4, 396, 396 1/4, 396 3/4, 397, 397 1/4, 397 3/4, 398, 398 1/4, 398 3/4, 399, 399 1/4, 399 3/4, 400, 400 1/4, 400 3/4, 401, 401 1/4, 401 3/4, 402, 402 1/4, 402 3/4, 403, 403 1/4, 403 3/4, 404, 404 1/4, 404 3/4, 405, 405 1/4, 405 3/4, 406, 406 1/4, 406 3/4, 407, 407 1/4, 407 3/4, 408, 408 1/4, 408 3/4, 409, 409 1/4, 409 3/4, 410, 410 1/4, 410 3/4, 411, 411 1/4, 411 3/4, 412, 412 1/4, 412 3/4, 413, 413 1/4, 413 3/4, 414, 414 1/4, 414 3/4, 415, 415 1/4, 415 3/4, 416, 416 1/4, 416 3/4, 417, 417 1/4, 417 3/4, 418, 418 1/4, 418 3/4, 419, 419 1/4, 419 3/4, 420, 420 1/4, 420 3/4, 421, 421 1/4, 421 3/4, 422, 422 1/4, 422 3/4, 423, 423 1/4, 423 3/4, 424, 424 1/4, 424 3/4, 425, 425 1/4, 425 3/4, 426, 426 1/4, 426 3/4, 427, 427 1/4, 427 3/4, 428, 428 1/4, 428 3/4, 429, 429 1/4, 429 3/4, 430, 430 1/4, 430 3/4, 431, 431 1/4, 431 3/4, 432, 432 1/4, 432 3/4, 433, 433			

Equipment for units composing a regiment of 155-mm. howitzer matériel, model of 1918 (Schneider) motorized, on war footing—Continued.

Number per organization.				Article.	Where carried.	Property classification.	
B.	H. C.	S. C.	R.			Class.	Division.
				<b>Load carried by the artillery repair truck—Continued.</b>			
.....		3	3	Wrench, pipe, 14-inch, "Trimo," metal handle, capacity $\frac{1}{2}$ to 1 $\frac{1}{2}$ inches.	A. R. T.....	} IV	9
.....		3	3	Wrench, 6-inch, "Crescent," adjustable, 22 $\frac{1}{2}$ ° angle, No. CA6.	A. R. T.....		
.....		3	3	Wrench, 8-inch, "Crescent," adjustable, 22 $\frac{1}{2}$ ° angle, No. CA8.	A. R. T.....		
.....		3	3	Wrench, 6-inch, adjustable.	A. R. T.....		
.....		3	3	Wrench, double end auto set 5A, semifinished for S. A. E. cap screws ( $\frac{1}{4}$ and $\frac{1}{2}$ inch, $\frac{3}{8}$ and $\frac{1}{2}$ inch, $\frac{5}{8}$ and $\frac{3}{4}$ inch, $\frac{7}{8}$ and $1\frac{1}{4}$ inch, $\frac{1}{2}$ and $\frac{3}{4}$ inch.)	A. R. T.....		
.....		3	3	Wrench, socket, set (hexagon steel sockets advancing 32nds from $\frac{1}{4}$ to 1 inch, also 1 $\frac{1}{4}$ , 1 $\frac{1}{2}$ , 1 $\frac{3}{4}$ , 1 $\frac{1}{2}$ inches; square steel sockets $\frac{1}{4}$ inch and $\frac{3}{8}$ inch; ratchet wrench with reversible pawl, spark plug wrench, universal joint and screw-driver bits).	A. R. T.....		
.....		3	3	Wrench, adjustable tap, length 7 inches for $\frac{1}{4}$ to $\frac{1}{2}$ inch.	A. R. T.....		
.....		3	3	Wrench, adjustable tap, length 11 inches for $\frac{1}{4}$ to $\frac{1}{2}$ inch.	A. R. T.....		
.....		3	3	Wrench, adjustable tap, length 15 inches for $\frac{1}{4}$ to $\frac{3}{4}$ inch.	A. R. T.....		
.....		3	3	Wrench, adjustable tap, length 20 inches for $\frac{1}{4}$ to 1 inch.	A. R. T.....		
.....		3	3	Wheel, Norton alundum, 1 $\frac{1}{2}$ by $\frac{3}{8}$ inches, grain 3860, grade N.	A. R. T.....	} X	10
.....		3	3	Wheel, Norton alundum, 4 $\frac{1}{2}$ by $\frac{3}{8}$ inches, grain 3860, grade N.	A. R. T.....		
.....		6	6	Wheels, Norton alundum, 10 by 1 inch, grain 48, grade O.	A. R. T.....		
				<b>Chassis equipment for the light repair truck.</b>			
.....		2	2	Batteries; extra for flashlight tungsten, American Eveready No. 793.	L. R. T.....	} IV	
.....		1	1	Bulbs, spare, for flashlight, mazda, No. 1197.	L. R. T.....		
.....		1	1	Can, oil.	L. R. T.....		
.....		1	1	Chisel, cold.	L. R. T.....		
.....		1	1	Cover, searchlight.	L. R. T.....		
.....		1	1	Carrier, tire, 34 by 4 inches, W. W. Sly No. 13.	L. R. T.....		
.....		2	2	Chains, antiskid, set, 33 by 4 inches, Weed.	L. R. T.....		
.....		12	12	Chains, cross, weed, 4 inches.	L. R. T.....		
.....		1	1	Cover, for radiator (furnished when required by special service).	L. R. T.....		
.....		5	5	Cores, valve plunger, complete for Schrader valve, in tin box.	L. R. T.....		
.....		3	3	Calcium carbide (carried in generator), pounds.	L. R. T.....		
.....		1	1	Calcium carbide, 2-pound cans.	L. R. T.....		
.....		1	1	Extinguisher, fire, complete with bracket, "Fyr-Fyter," "Pyrene," or equal.	L. R. T.....		
.....		1	1	Flashlight, American Eveready No. 1991, without rubber hood.	L. R. T.....		
.....		1	1	File, magento, "Disston's"	L. R. T.....		
.....		1	1	Gun, grease.	L. R. T.....		
.....		1	1	Gage, tire pressure, "Schrader"	L. R. T.....		
.....		1	1	Generator, acetylene, complete with bracket, Solar No. 1012B.	L. R. T.....		
.....		1	1	Hammer.	L. R. T.....		
.....		1	1	Handle, socket wrench.	L. R. T.....		
.....		2	2	Irons, tire, Canton No. 13, W. Bingham Co., Cleveland.	L. R. T.....		
.....		1	1	Jack and handle.	L. R. T.....		
.....		2	2	Lamps, side, oil, Adlake type No. 4481.	L. R. T.....		
.....		1	1	Lamp, tail, oil, Adlake type No. 4482.	L. R. T.....		
.....		1	1	Panoh.	L. R. T.....		
.....		1	1	Pump, tire.	L. R. T.....		
.....		1	1	Pliers.	L. R. T.....		
.....		1	1	Paulin, 12 by 12 feet.	L. R. T.....		
.....		4	4	Plugs, spark, $\frac{3}{8}$ -inch S. A. E. "Titan"	L. R. T.....		
.....		1	1	Pliers, chain repair, Weed.	L. R. T.....		

*Equipment for units composing a regiment of 155-mm. howitzer matériel, model of 1918  
(Schneider) motorized, on war footing—Continued.*

Number per organization.				Article.	Where carried.	Property classification.	
B.	H. C.	S. C.	R.			Class.	Division.
				<b>Chassis equipment for the light repair truck—Continued.</b>			
		2	2	Patches, blowout, for 34 by 4 inch tires, Goodyear Rubber Co., or equal.	L. R. T.	IV	9
		1	1	Rim, extra, for 33 by 4 inch tire (Dodge).	L. R. T.		
		1	1	Speedometer, Johns-Manville, complete with shaft and driving gears.	L. R. T.		
		1	1	Screw driver.	L. R. T.		
		1	1	Searchlight, acetylene, complete with yoke and bracket, Solar, No. 167.	L. R. T.		
		1	1	Signal, hand, warning, "Klaxon," K-3, "Stewart," No. 114, "Long Horn," Model J, or equal.	L. R. T.		
		1	1	Tool kit.	L. R. T.		
		2	2	Tips, lava, $\frac{1}{2}$ cubic foot per hour, for searchlight.	L. R. T.		
		1	1	Tire, spare, 33 by 4 inches, Goodyear, or equal.	L. R. T.		
		2	2	Tubes, inner, 33 by 4 inches (1 on spare wheel; 1 in bag).	L. R. T.		
		1	1	Tool, valve repair, Schrader Universal.	L. R. T.		
		1	1	Wrench, rim.	L. R. T.		
		1	1	Wrench, spark plug.	L. R. T.		
		1	1	Wrench, main-bearing-socket.	L. R. T.		
		1	1	Wrench, gear-case-cover.	L. R. T.		
		2	2	Wrenches, valve-lifter-adjusting.	L. R. T.		
		1	1	Wrench, spanner, starter-adjusting-nut.	L. R. T.		
		1	1	Wrench, spanner, starter-adjusting-ring.	L. R. T.		
		1	1	Wrench, open-end.	L. R. T.		
		1	1	Wrench, hub-cap.	L. R. T.		
		1	1	Wrench, monkey.	L. R. T.		
		1	1	Wrench, magneto, "Eisemann".	L. R. T.		
				<b>Body equipment for the light repair truck.</b>			
		1	1	Ax.	L. R. T.	X	10
		2	2	Buckets, canvas, water.	L. R. T.		
		1	1	Can, safety, 1-gallon.	L. R. T.		
		1	1	Cover, canvas, for body.	L. R. T.		
		1	1	Crowbar, 60-inch.	L. R. T.		
		1	1	Hatchet.	L. R. T.		
		1	1	Lantern, complete.	L. R. T.		
		1	1	Oil, medium, gasoline engine, gallons.	L. R. T.		
		2	2	Pads, lantern-bracket, complete.	L. R. T.		
		1	1	Shovel, short handle.	L. R. T.		
		2	2	Straps, lantern.	L. R. T.		
		2	2	Straps, 12 inches long, style AV, 7 holes, 1 for ax handle, 1 for hatchet handle.	L. R. T.		
		3	3	Strap, 15 inches long, style AV, 7 holes, 1 for shovel handle, 2 for crowbar.	L. R. T.		
		1	1	Strap, 22.75 inches long, style AV, 7 holes, 1 for water bucket.	L. R. T.		
		2	2	Strap, 42 inches long, style ATK, 6 holes, 2 for paulin.	L. R. T.		
		1	1	Strap, 54 inches long, style AV, 10 holes, 1 for tire.	L. R. T.		
		1	1	Top over driver's seat, with storm curtains.	L. R. T.		
				<b>Load carried by the light repair truck.</b>			
		1	1	Bolts, stove, with nuts, round-head, $\frac{1}{2}$ by 1 inch, pound.	L. R. T.	IV	9
		1	1	Bolts, stove, with nuts, round-head, $\frac{1}{2}$ by $1\frac{1}{2}$ inches, pound.	L. R. T.		
		1	1	Bolts, stove, with nuts, round-head, $\frac{3}{4}$ by 1 inch, pound.	L. R. T.		
		1	1	Bolts, stove, with nuts, round-head, $\frac{3}{4}$ by $1\frac{1}{2}$ inches, pound.	L. R. T.		
		6	6	Blades, hacksaw, assorted pitch, dozen.	L. R. T.		
		1	1	Brace, valve-grinding.	L. R. T.		
		1	1	Chest, carpenter's, with contents listed under load "A" of the artillery supply truck.	L. R. T.		
		1	1	Chest, light machine tool.	L. R. T.		
		1	1	Chest, light auto supply.	L. R. T.		
		1	1	Chest, duplex chain block.	L. R. T.		
		1	1	Block, duplex chain Y. & T., 2-ton.	L. R. T.		
		1	1	Chest, light auto lubricant.	L. R. T.		

Equipment for units composing a regiment of 155-mm. howitzer matériel, model of 1918 (Schneider) motorized, on war footing—Continued.

Number per organization.				Article.	Where carried.	Property classification.	
B.	H. C.	S. C.	R.			Class.	Division.
				<b>Load carried by the light repair truck—Continued.</b>			
		1	1	Calipers, inside, spring, 6-inch	L. R. T.	X	9
		1	1	Calipers, outside, spring, 6-inch	L. R. T.		
		1	1	Clippers, bolt, 18 inches long, $\frac{1}{8}$ -inch capacity	L. R. T.		
		1	1	Copper, soldering, 1½ pounds, pointed pattern with handle	L. R. T.	X	10
		1	1	Copper, soldering, jeweler's size, pointed pattern with handle	L. R. T.		
		1	1	Chisel, cold, $\frac{3}{8}$ by 6 inches	L. R. T.	X	9
		1	1	Chisel, cold, $\frac{1}{2}$ by 6 inches	L. R. T.		
		1	1	Chisel, cold, $\frac{3}{4}$ by 8 inches	L. R. T.		
		25	25	Cable, high tension, No. 18, rubber covered, feet	L. R. T.	X	10
		1	1	Cement, radiator, 2-pound package	L. R. T.		
		2	2	Clamps, "C," malleable iron, 7 inches, adjustable	L. R. T.	X	9
		1	1	Chalk, carpenter's, white, box	L. R. T.		
		12	12	Clamp, hose, Cooper adjustable	L. R. T.	X	9
		6	6	Cement, tire, tube	L. R. T.		
		1	1	Cloth, emery, No. 00, quire	L. R. T.	X	10
		1	1	Cloth, emery, No. 0, quire	L. R. T.		
		1	1	Cloth, emery, No. $\frac{1}{2}$ , quire	L. R. T.		
		2	2	Compound, "Duplex," valve grinding, in 7-ounce can	L. R. T.	X	10
		1	1	Corks, small, $\frac{3}{8}$ to 1 inch diameter, gross	L. R. T.		
		4	4	Couplings, complete, copper, to fit $\frac{1}{2}$ -inch O. D. copper tubing	L. R. T.	X	9
		1	1	Crowbar, 36 inches	L. R. T.		
		1	1	Cutter, pipe, 1 wheel and 2 rollers, "Trimo" No. 1	L. R. T.	X	9
		1	1	Drift, copper, 4 by $\frac{3}{8}$ inch	L. R. T.		
		1	1	Drift, copper, 6 by $\frac{3}{8}$ inch	L. R. T.	X	9
		1	1	Drift, steel, $\frac{1}{8}$ -inch point, 5.6 inches long	L. R. T.		
		1	1	Drill, press	L. R. T.		
		1	1	Drill, hand	L. R. T.	X	9
		29	29	Drills, twist, carbon steel, straight shank, backed off, standard length as follows:	L. R. T.		
				4 each size, Nos. 48 and 36	L. R. T.	X	9
				4 each size, $\frac{1}{8}$ , $\frac{1}{4}$ , and $\frac{3}{8}$ inch	L. R. T.		
				2 each size, $\frac{1}{2}$ , $\frac{3}{4}$ , and $\frac{1}{2}$ inch	L. R. T.		
				1 each size, $\frac{1}{2}$ , $\frac{3}{4}$ , and $\frac{1}{2}$ inch	L. R. T.		
				1 each size, $\frac{1}{2}$ , $\frac{3}{4}$ , and $\frac{1}{2}$ inch	L. R. T.		
		1	1	Extractor, screw, "Ezy Out," set No. 15	L. R. T.	X	9
		2	2	Files, triangular, 6 inches	L. R. T.		
		2	2	Files, triangular, 8 inches	L. R. T.	X	9
		6	6	Files, flat, magneto, "Disston's"	L. R. T.		
		1	1	File, round bastard, 4 by $\frac{1}{8}$ inch	L. R. T.	X	9
		1	1	File, round bastard, 6 by $\frac{1}{8}$ inch	L. R. T.		
		1	1	File, round bastard, 8 by $\frac{1}{8}$ inch	L. R. T.		
		1	1	File, round bastard, 10 by $\frac{1}{8}$ inch	L. R. T.		
		1	1	File, round bastard, 12 by $\frac{1}{8}$ inch	L. R. T.		
		5	5	Files, flat bastard, double cut, 10 inches long	L. R. T.		
		1	1	Frame hacksaw, adjustable	L. R. T.		
		1	1	Felt, washer, medium hard, 12 by 12 by $\frac{3}{8}$ inch piece	L. R. T.		
		1	1	Gage, screw pitch, U. S. standard	L. R. T.		
		1	1	Gage, drill	L. R. T.		
		1	1	Gage, thickness	L. R. T.		
		2	2	Gause, brass wire 40-mesh, pounds	L. R. T.	X	10
		10	10	Grease, graphite, Dixon's or equal, pounds	L. R. T.		
		1	1	Grease, for compression cups, "Keystone," gallon	L. R. T.	X	9
		1	1	Grinder, wheel, hand	L. R. T.		
		2	2	Graphite, flake, medium	L. R. T.	X	10
		1	1	Gun, grease and oil, with 2 nozzles	L. R. T.		
		1	1	Hammer, riveting, plain eye, size 18-ounce	L. R. T.	X	9
		1	1	Hammer, machinist's ball pein, No. 00, 17-ounce	L. R. T.		
		2	2	Handles, file, aluminum	L. R. T.		
		1	1	Jack, "Barth," 2-ton	L. R. T.	X	10
		1	1	Lacing, belt, steel wire, pound	L. R. T.		
		2	2	Lead, white, ground in oil, pounds	L. R. T.	X	10
		1	1	Nails, 20 dwt., pounds	L. R. T.		
		5	5	Nails, 10 dwt., pounds	L. R. T.	X	10
		5	5	Nails, finishing, 10 dwt., pounds	L. R. T.		

Equipment for units composing a regiment of 155-mm. howitzer matériel, model of 1918 (Schneider) motorized, on war footing—Continued.

Number per organization.				Article.	Where carried.	Property classification.	
B.	H. C.	S. C.	R.			Class.	Division.
				<b>Load carried by the light repair truck—Continued.</b>			
		50	50	Nuts, steel, U. S. standard, $\frac{1}{2}$ , $\frac{3}{8}$ , $\frac{1}{2}$ , $\frac{3}{4}$ inch (10 each).	L. R. T.	X	10
		1	1	Oiler, dome type.	L. R. T.	X	9
		1	1	Outfit, vulcanizing, "Vul-kit," gasoline, type G, No. 32.	L. R. T.		
		2	2	Packing, sheet, "semibronze," for gaskets, pounds.	L. R. T.	X	10
		6	6	Patches, blow-out, for 36 by 6 inch cord.	L. R. T.		
		2	2	Patches, for inner tubes, assorted sizes, dozen.	L. R. T.	X	10
		1	1	Paste, soldering, pound.	L. R. T.		
		1	1	Pins, drive, Starrett Co., No. 565, set.	L. R. T.	X	10
		5	5	Pins, cotter, assorted sizes, ranging from $\frac{1}{8}$ to $\frac{1}{2}$ inch, pounds.	L. R. T.		
		1	1	Plate, screw, taps and dies, U. S. standard, with tap wrench, including chest (drawing 76-7-77).	L. R. T.	X	10
		1	1	Pliers, chain nose, file jaw.	L. R. T.		
		1	1	Pliers, wire cutting, 8 inches.	L. R. T.	X	9
		1	1	Puller, nail, Simmons's.	L. R. T.		
		1	1	Puller, cotter pin, $\frac{3}{8}$ by $6\frac{1}{2}$ inches.	L. R. T.	X	9
		1	1	Punch, revolving, for leather.	L. R. T.		
		1	1	Punch, center, $4\frac{1}{2}$ inches long.	L. R. T.	X	10
		1	1	Reamer, burring, $1\frac{1}{2}$ inches.	L. R. T.		
		1	1	Reamers, taper pin, set ( $\frac{1}{4}$ -inch taper in 12 inches)	L. R. T.	X	10
		2	2	Rivets and burrs, assorted sizes, copper, pounds.	L. R. T.		
		75	75	Rope, wire, hemp core, $\frac{1}{2}$ -inch, feet.	L. R. T.	X	10
		1	1	Sandpaper, No. 60, quire.	L. R. T.		
		1	1	Sandpaper, No. 24, quire.	L. R. T.	X	10
		1	1	Salt, soldering, pound.	L. R. T.		
		1	1	Scale, steel, 12-inch, graduated to 64ths inch.	L. R. T.	X	9
		1	1	Screw driver, 3-inch blade.	L. R. T.		
		1	1	Screw driver, 5-inch blade.	L. R. T.	X	9
		1	1	Set, rivet, No. 3.	L. R. T.		
		1	1	Set, rivet, No. 5.	L. R. T.	X	10
		1	1	Scraper, bearing, $3\frac{1}{2}$ by $\frac{1}{2}$ inch blade.	L. R. T.		
		1	1	Shears, 8-inch heavy.	L. R. T.	X	9
		1	1	Shellac, orange, quart.	L. R. T.		
		1	1	Sledge, model 1907.	L. R. T.	X	10
		1	1	Snips, tinner's, 10-inch, straight pattern.	L. R. T.		
		5	5	Solder, half and half, pounds.	L. R. T.	X	9
		5	5	Solder, wire, in 1-pound lot, pounds.	L. R. T.		
		10	10	Spikes, 40 dwt., pounds.	L. R. T.	X	10
		5	5	Staples, 1-inch galvanized iron, pounds.	L. R. T.		
		1	1	Stone, carborundum, coarse and fine combined, 6 by 2 by 1 inch.	L. R. T.	X	10
		4	4	Tape, friction, $\frac{1}{2}$ -inch, $\frac{1}{2}$ -pound roll.	L. R. T.		
		4	4	Tape, rubber, $\frac{1}{2}$ -inch, $\frac{1}{2}$ -pound roll.	L. R. T.	X	9
		1	1	Tape, steel, 50 feet.	L. R. T.		
		1	1	Taps and dies, S. A. E. standard, $\frac{1}{2}$ to 1 inch, with stock and tap wrench, set.	L. R. T.	X	10
		1	1	Tools, pipe threading, set.	L. R. T.		
		4	4	Tools, tire valve.	L. R. T.	X	9
		1	1	Torch, gasoline, Turner No. 92, double jet, 1 quart.	L. R. T.		
		25	25	Tubing, copper, $\frac{1}{2}$ -inch O. D., feet.	L. R. T.	X	10
		2	2	Twine, hemp, pounds.	L. R. T.		
		1	1	Tool, valve lifting.	L. R. T.	X	9
		1	1	Vise, hand.	L. R. T.		
		1	1	Vise, machinist's, swivel jaw and swivel base, $3\frac{1}{2}$ -inch, Prentiss No. 19.	L. R. T.	X	10
		30	30	Washers, lock, S. A. E., heavy, $\frac{1}{2}$ -inch.	L. R. T.		
		30	30	Washers, lock, S. A. E., heavy, $\frac{3}{8}$ -inch.	L. R. T.	X	9
		30	30	Washers, lock, S. A. E., heavy, $\frac{1}{2}$ -inch.	L. R. T.		
		30	30	Washers, lock, S. A. E., heavy, $\frac{3}{8}$ -inch.	L. R. T.	X	10
		30	30	Washers, lock, S. A. E., heavy, $\frac{1}{2}$ -inch.	L. R. T.		
		30	30	Washers, lock, S. A. E., heavy, $\frac{3}{8}$ -inch.	L. R. T.	X	9
		30	30	Washers, lock, S. A. E., heavy, $\frac{1}{2}$ -inch.	L. R. T.		
		2	2	Wire, copper, No. 20 B. & S., spools.	L. R. T.	X	10
		4	4	Wire, copper, No. 14 B. & S., spools.	L. R. T.		
		24	24	Wire, soft steel, No. 20 B. & S., spools.	L. R. T.	X	9
		1	1	Wrench, "S," adjustable, Wescott pattern.	L. R. T.		
		1	1	Wrench, pipe, 6-inch, "Trimo"	L. R. T.	IV	9

Equipment for units composing a regiment of 155-mm. howitzer matériel, model of 1918  
(Schneider) motorized, on war footing—Continued.

Number per organization.				Article.	Where carried.	Property classification.	
B.	H. C.	S. C.	R.			Class.	Division.
				<b>Load carried by the light repair truck—</b>			
				Continued.			
		1	1	Wrench, pipe, 10-inch, "Trimo".....	L. R. T.	IV	9
		1	1	Wrench, pipe, 14-inch, "Trimo".....	L. R. T.		
		1	1	Wrench, monkey, 15-inch, "Trimo".....	L. R. T.		
		1	1	Wrench, screw, 12-inch, auto monkey.....	L. R. T.		
		1	1	Wrench, patent ratchet, with socket.....	L. R. T.		
		1	1	Wrench, "S," adjustable, Wescott's No. 78.....	L. R. T.		
		1	1	Wrench, "S," adjustable, Wescott's No. 80.....	L. R. T.		
		1	1	Wrench, "S," adjustable, Wescott's No. 82.....	L. R. T.		
		10	10	Waste, white cotton, pounds.....	L. R. T.		
		1	1	Wrench, "Rostand," adjustable No. 1, Rostand Manufacturing Co., Milford, Conn.....	L. R. T.		
		2	2	Wicking, cotton, candle, $\frac{1}{8}$ -inch, balls.....	L. R. T.	X	10
				<b>Chassis equipment for the staff observation car.</b>			
1	4		10	Battery, Williard, *Str. 4, Government, No. 4701-YS or equal, formed and ready for service.....	S. O. C.	IV	9
2	8		20	Batteries, extra for flashlight, tungsten, American Eveready, No. 793.....	S. O. C.		
1	4		10	Belt, fan.....	S. O. C.		
1	4		10	Book, instruction.....	S. O. C.		
1	4		10	Book, magneto.....	S. O. C.		
1	4		10	Boot, crank.....	S. O. C.		
1	4		10	Box, tool, with 3 trays.....	S. O. C.		
1	4		10	Bulb, extra for flashlight, Mazda, American Eveready or equal, No. 1197.....	S. O. C.		
1	4		10	Bumper, front, with towing hooks.....	S. O. C.		
1	4		10	Case, lamp bulb.....	S. O. C.		
2	8		20	Bulbs, 6V, 24 candlepower, G 16 $\frac{1}{2}$ or equal.....	S. O. C.	IV	9
2	8		20	Bulbs, 6V, 8 candlepower, G 10 or equal.....	S. O. C.		
1	4		10	Bulbs, 6V, 4 candlepower, G 8 or equal.....	S. O. C.		
2	8		20	Bulbs, 6V, 2 candlepower, G 6 or equal.....	S. O. C.		
2	8		20	Chains, tire, 3 $\frac{1}{2}$ by 6 inches, Weed or equal, sets.....	S. O. C.		
1	4		10	Chain, towing, "American," American Chain Co., No. 2800.....	S. O. C.		
2	8		20	Cover, for Hall No. 479 headlight.....	S. O. C.	IV	3
1	4		10	Cover, for radiator (furnished when required by special service).....	S. O. C.		
1	4		10	Drift, copper, $\frac{1}{2}$ by 4 inches.....	S. O. C.	X	9
1	4		10	Drift, copper, $\frac{1}{2}$ by 6 inches.....	S. O. C.		
1	4		10	Extinguisher, fire, complete with bracket, "Fyrfyter," "Pyrene," or equal.....	S. O. C.	IV	9
1	4		10	File and handle.....	S. O. C.	X	9
1	4		10	Flashlight, American Eveready, No. 1991, without rubber hood.....	S. O. C.		
1	4		10	Gasket, carburetor nozzle plug.....	S. O. C.	X	10
1	4		10	Gasket, carburetor intake pipe, upper.....	S. O. C.		
1	4		10	Gasket, carburetor intake pipe, lower.....	S. O. C.		
6	24		60	Gaskets, engine cylinder and valve plug.....	S. O. C.		
4	16		40	Glands, oil line compression union.....	S. O. C.		
1	4		10	Gun, grease.....	S. O. C.		
1	4		10	Gun, oil.....	S. O. C.		
1	4		10	Hammer.....	S. O. C.		
1	4		10	Handle, wrench, carburetor socket.....	S. O. C.		
1	4		10	Handle, valve plug socket wrench.....	S. O. C.		
1	4		10	Jack and handle.....	S. O. C.		
2	8		20	Keys, engine valve spring.....	S. O. C.	IV	9
2	8		20	Lamps, head, Hall No. 479 or equal.....	S. O. C.		
2	8		20	Lamps, side, Adlake No. 4496.....	S. O. C.		
1	4		10	Lamp, tail, Adlake No. 4497.....	S. O. C.		
1	4		10	Lamp, dash, Vesta No. 70 or equal.....	S. O. C.		
1	4		10	Lamp, extension, with cord.....	S. O. C.		
1	4		10	Nozzle, carburetor, low speed.....	S. O. C.		
1	4		10	Nozzle, carburetor, high speed.....	S. O. C.		
1	4		10	Nozzle, carburetor, starting.....	S. O. C.		
4	24		40	Nuts, oil line compression, union gland.....	S. O. C.		
1	4		10	Outfit, tire repair.....	S. O. C.	X	9
1	4		10	Paulin, 12 by 12 feet.....	S. O. C.		
30	120		300	Pins, cotter, extra.....	S. O. C.	X	10
3	12		30	Pins, fan belt connector.....	S. O. C.		

Equipment for units composing a regiment of 155-mm. howitzer matériel, model of 1918 (Schneider) motorized, on war footing—Continued.

Number per organization.				Article.	Where carried.	Property classification.	
B.	H. C.	S. C.	R.			Class.	Division.
				<b>Chassis equipment for the staff observation car—Continued.</b>			
1	4		10	Pliers.....	S. O. C.....	X	9
2	8		20	Plug, spark.....	S. O. C.....	IV	9
1	4		10	Fuller, cotter pin.....	S. O. C.....	X	9
1	4		10	Pump, tire, hand.....	S. O. C.....	IV	9
1	4		10	Rim, demountable, Firestone-Kesley, 36 by 6 inches.....	S. O. C.....		
1	4		10	Screw driver, 3 inches.....	S. O. C.....	IV	9
1	4		10	Screw driver, 6 inches.....	S. O. C.....		
1	4		10	Signal, hand, warning, "Klaxon" No. K-3, "Stewart" No. 114, "Long Horn," model J, or equal.....	S. O. C.....		
1	4		10	Speedometer, Stewart Warner 67A or equal.....	S. O. C.....		
2	8		20	Springs, engine valve.....	S. O. C.....	X	10
2	8		20	Straps, kick.....	S. O. C.....		
1	4		10	Syringe, battery hydrometer.....	S. O. C.....		
1	4		10	Tape, friction, 1/4-inch, roll.....	S. O. C.....		
1	4		10	Tire, 36 by 6 inches, pneumatic, Goodyear or equal.....	S. O. C.....		
2	8		20	Tubes, inner, 36 by 6 inches.....	S. O. C.....		
2	8		20	Valves, engine.....	S. O. C.....		
2	8		20	Valves, oil pump, check, complete.....	S. O. C.....		
1	4		10	Wire, copper, No. 18, 25-foot spool.....	S. O. C.....		
1	4		10	Wrench, auto, 9-inch.....	S. O. C.....		
1	4		10	Wrench, bicycle.....	S. O. C.....	IV	9
1	4		10	Wrench, magneto.....	S. O. C.....		
1	4		10	Wrench, M. hub.....	S. O. C.....		
1	4		10	Wrench, open end, No. 25.....	S. O. C.....		
1	4		10	Wrench, open end, No. 31.....	S. O. C.....		
1	4		10	Wrench, open end, No. 27.....	S. O. C.....		
1	4		10	Wrench, open end, No. 29.....	S. O. C.....		
2	8		20	Wrenches, valve adjusting.....	S. O. C.....		
1	4		10	Wrench, carburetor socket.....	S. O. C.....		
1	4		10	Wrench, demountable rim.....	S. O. C.....		
1	4		10	Wrench, valve plug socket.....	S. O. C.....		
				<b>Body equipment for the staff observation car.</b>			
1	4		10	Ax.....	S. O. C.....	IV	9
1	4		10	Board, wood table for map and plotting work.....	S. O. C.....		
2	8		20	Buckets, canvas, water, complete.....	S. O. C.....		
1	4		10	Can, safety, 1 gallon.....	S. O. C.....		
1	4		10	Hatchet.....	S. O. C.....		
1	4		10	Lantern, complete.....	S. O. C.....		
1	4		10	Mat, cocoa fiber.....	S. O. C.....		
1	4		10	Oil, medium, gasoline engine, gallon.....	S. O. C.....		
2	8		20	Pads, lantern bracket, complete.....	S. O. C.....		
1	4		10	Shovel, long handle.....	S. O. C.....		
1	4		10	Shovel, short handle.....	S. O. C.....		
1	4		20	Shovels, lantern.....	S. O. C.....		
3	12		30	Straps, 12 inches long, style AV, 7 holes, 1 for ax, 1 for long-handle shovel, 1 for hatchet.....	S. O. C.....		
2	8		20	Straps, 15 inches long, style AV, 7 holes, 1 for long-handle shovel, 1 for short-handle shovel.....	O. O. C.....		
				<b>Chassis equipment for the reconnaissance car.</b>			
2			12	Batteries, extra, for flash light, tungsten.....	R. C.....	IV	9
1			6	Belt, fan.....	R. C.....		
1			6	Book, instruction, No. 1972.....	R. C.....		
1			6	Book, magneto.....	R. C.....		
1			6	Boot, crank.....	R. C.....		
1			6	Box, tool, with 3 trays.....	R. C.....		
1			6	Bulb, extra, for flash lights, Mazda.....	R. C.....		
1			6	Bumper, front, with towing hooks.....	R. C.....		
3			18	Calcium carbide, carried in generator..... pounds.....	R. C.....		
1			6	Calcium carbide, 2-pound can.....	R. C.....		
2			12	Chains, tire, 36 by 6 inches.....	R. C.....		
1			6	Chain, towing.....	R. C.....		
1			6	Cover, for radiator (furnished when required for special service).....	R. C.....		

Equipment for units composing a regiment of 155-mm. howitzer matériel, model of 1918  
(Schneider) motorized, on war footing—Continued.

Number per organization.				Article.	Where carried.	Property classification.			
B.	H. C.	S. C.	R.			Class.	Division.		
				<b>Chassis equipment for the reconnaissance car—Continued.</b>					
1			6	Cover, searchlight, canvas.....	R. C.	IV	9		
1			6	Drift, copper, 1 by 4 inches.....	R. C.				
1			6	Drift, copper, 1 by 6 inches.....	R. C.				
1			6	Extinguisher, fire, complete with bracket.....	R. C.				
1			6	File and handle.....	R. C.				
1			6	Flash light without rubber hood.....	R. C.				
1			6	Gasket, carburetor nozzle plug.....	R. C.				
1			6	Gasket, carburetor intake pipe, upper.....	R. C.				
1			6	Gasket, carburetor intake pipe, lower.....	R. C.				
6			36	Gasket, engine cylinder and valve plug.....	R. C.				
1			6	Generator, acetylene.....	R. C.				
4			24	Gland, oil line compression union.....	R. C.				
1			6	Gun, grease.....	R. C.				
1			6	Gun, oil.....	R. C.				
1			6	Hammer.....	R. C.				
1			6	Handle, wrench, carburetor, socket.....	R. C.				
1			6	Handle, valve plug socket wrench.....	R. C.				
1			6	Jack and handle.....	R. C.				
2			12	Keys, engine valve spring.....	R. C.				
2			12	Lamp, side.....	R. C.				
1			6	Lamp, tail.....	R. C.				
1			6	Nozzle, carburetor, low speed.....	R. C.				
1			6	Nozzle, carburetor, high speed.....	R. C.				
1			6	Nozzle, carburetor, starting.....	R. C.				
4			24	Nuts, oil line compression union gland.....	R. C.				
1			6	Outfit, tire repair.....	R. C.				
1			6	Paulin, 12 by 12 feet.....	R. C.				
30			180	Pins, cotter, extra.....	R. C.				
3			18	Pins, fan belt connector.....	R. C.				
1			6	Pliers.....	R. C.				
2			12	Plugs, spark.....	R. C.				
1			6	Puller, cotter pin.....	R. C.				
1			6	Pump, tire, hand.....	R. C.				
1			6	Rim, demountable, Firestone.....	R. C.				
1			6	Screw driver, 3-inch.....	R. C.				
1			6	Screw driver, 6-inch.....	R. C.				
1			6	Signal, hand, warning.....	R. C.				
1			6	Searchlight, acetylene, complete with yoke and bracket.....	R. C.				
1			6	Speedometer, Stewart Warner 67A, or equal.....	R. C.				
2			12	Springs, engine valve.....	R. C.				
2			12	Straps, kick.....	R. C.				
1			6	Tape, friction, 2-inch, roll.....	R. C.				
1			6	Tire, 36 by 6 inches, pneumatic, Goodyear or equal.....	X	10			
2			12	Tubes, inner, 36 by 6 inches.....	R. C.	IV	9		
2			12	Valves, engine.....	R. C.				
2			12	Valves, oil pump, check, complete.....	R. C.				
1			6	Wire, copper, No. 18, 25-foot spool.....	R. C.			X	10
1			6	Wrench, auto, 9-inch.....	R. C.				
1			6	Wrench, bicycle.....	R. C.				
1			6	Wrench, magneto.....	R. C.				
1			6	Wrench, M. hub.....	R. C.				
1			6	Wrench, open-end No. 25.....	R. C.				
1			6	Wrench, open-end No. 31.....	R. C.				
1			6	Wrench, open-end No. 27.....	R. C.				
1			6	Wrench, open-end No. 29.....	R. C.				
2			12	Wrenches, valve-adjusting.....	R. C.				
1			6	Wrench, carburetor socket.....	R. C.	IV	9		
1			6	Wrench, demountable rim.....	R. C.				
1			6	Wrench, valve plug socket.....	R. C.				
				<b>Body equipment for the reconnaissance car.</b>					
1			6	Ax.....	R. C.				
2			12	Bucket, water, canvas, complete.....	R. C.				
1			6	Can, safety, 1-gallon.....	R. C.				
1			6	Hatchet.....	R. C.				
1			6	Lantern, complete.....	R. C.				
1			6	Mat, cocoa fiber.....	R. C.				

Equipment for units composing a regiment of 155-mm. howitzer matériel, model of 1918 (Schneider) motorized, on war footing—Continued.

Number per organization.				Article.	Where carried.	Property classification.	
B.	H. C.	S. C.	R.			Class.	Division.
				<b>Body equipment for the reconnaissance car—Continued.</b>			
1			6	Oil, medium, gasoline engine, gallon.	R. C.	X	10
2			12	Pads, lantern bracket, complete.	R. C.		
1			6	Shovel, long-handle.	R. C.	IV	9
1			6	Shovel, short-handle.	R. C.		
2			12	Straps, lantern.	R. C.		
3			18	Straps, 12 inches long, style AV, 7 holes (1 for ax, 1 for long-handle shovel, 1 for hatchet).	R. C.		
1			6	Straps, 15 inches long, style AV, 7 holes (1 for long-handle shovel).	R. C.		
				<b>Equipment for the 2½-ton artillery tractor.</b>			
1	4		10	Armor, inclosing engine, radiator, and fuel tank, complete, set.	2½ T. T.	IV	10
1	4		10	Ax.	2½ T. T.		
2	8		20	Belt, fan.	2½ T. T.	IV	9
1	4		10	Box, motor vehicle tool, model 1918, containing tools and accessories as hereinafter listed.	2½ T. T.		
1	4		10	Buckets, canvas, water.	2½ T. T.		
2	8		20	Can, safety, 1-gallon.	2½ T. T.		
1	4		10	Cover, for radiator (furnished when required by special service).	2½ T. T.	IV	9
1	4		10	Drift steel, 8 inches long, tapering from ¼ to 1 inch.	2½ T. T.		
1	4		10	Extinguisher, fire, complete with bracket, "Fyr-Fyter," "Pyrene," or equal.	2½ T. T.	IV	9
2	8		20	Hatchets.	2½ T. T.		
1	4		10	Lamp, side, right.	2½ T. T.	IV	9
1	4		10	Lamp, side, left.	2½ T. T.		
1	4		10	Lamp, tail.	2½ T. T.		
1	4		10	Lantern, complete.	2½ T. T.		
1	4		10	Mattock, pick.	2½ T. T.	X	10
1	4		10	Oil, medium, gasoline engine, gallon.	2½ T. T.		
2	8		20	Pads, lantern bracket, complete.	2½ T. T.	IV	9
1	4		10	Paulin, 12 by 12 inches.	2½ T. T.		
1	4		10	Shovel, short-handle.	2½ T. T.		
3	12		30	Straps, 12 inches long, style AV, 7 holes (1 for ax handle, 2 for hatchet handle).	2½ T. T.		
2	4		20	Straps, lantern.	2½ T. T.	IV	9
1	4		10	Strap, 22.75 inches long, style AV, 7 holes, 1 for water buckets.	2½ T. T.		
1	4		10	Strap, 15 inches long, style AV, 7 holes, 1 for short-handle shovel.	2½ T. T.	IV	9
1	4		10	Strap, 15 inches long, style AVS, 7 holes, 1 for pick mattock.	2½ T. T.		
2	8		20	Wrenches, magneto.	2½ T. T.	IV	9
1	4		10	Wrench, water pump.	2½ T. T.		
1	4		10	Wrench, special set-screw.	2½ T. T.		
1	4		10	Wrench, socket, special for gear and axle shaft nut.	2½ T. T.		
1	4		10	Wrench, brace, for assembling grousers, and armor-front plate.	2½ T. T.	IV	10
				<b>Equipment for the 5-ton artillery tractor.</b>			
10			60	Armor, inclosing engine, radiator and fuel tank, fuel tank, complete set.	5 T. T.	IV	10
10			60	Ax.	5 T. T.		
20			120	Belt, fan.	5 T. T.	IV	9
20			120	Bucket, canvas, water.	5 T. T.		
1			6	Bracket for steering clutch spring tool.	5 T. T.	IV	10
10			60	Box, motor vehicle tool, model 1918 containing tools and accessories hereinafter listed.	5 T. T.		
10			60	Can, safety, 1 gallon.	5 T. T.	IV	9
10			60	Cover for radiator (furnished when required for special service).	5 T. T.		
10			60	Extinguisher, fire, Pyrene, quart size, filled, complete, including bracket.	5 T. T.	X	11
10			60	"Handbook of the 5-ton Artillery Tractor, Model 1917, No. 1996."	5 T. T.		
20			120	Hatchets.	5 T. T.	IV	9
10			60	Handle, ratchet socket wrench, "Mossberg."	5 T. T.		
10			60	Handle, offset socket wrench, "Mossberg."	5 T. T.		

Equipment for units composing a regiment of 155-mm. howitzer matériel, model of 1918  
(Schneider) motorized, on war footing—Continued.

Number per organization.				Article.	Where carried.	Property classification.	
B.	H. C.	S. C.	R.			Class.	Division.
				<b>Equipment for the 5-ton artillery tractor—Continued.</b>			
10			60	Joint, universal, "Mossberg".....	5 T. T.	IV	10
60			360	Lacing, fan belt, rawhide, 1 $\frac{1}{4}$ by 42 inches.....	5 T. T.		
10			60	Lantern, complete.....	5 T. T.	IV	9
10			60	Lamp, side, right.....	5 T. T.		
10			60	Lamp, side, left.....	5 T. T.		
10			60	Lamp, tail.....	5 T. T.		
10			60	Mattock, pick.....	5 T. T.	X	10
10			60	Oil, medium, gasoline engine, gallon.....	5 T. T.		
1			6	Pin for socket wrench.....	5 T. T.	IV	9
20			120	Pads, lantern bracket, complete.....	5 T. T.		
10			60	Paulin, 12 by 12 feet.....	5 T. T.		
30			180	Straps, 12 inches long, style AV, 7 holes, 1 for ax handle, 2 for hatchet handles.....	5 T. T.		
20			120	Straps, lantern.....	5 T. T.	IV	9
10			60	Strap, 15 inches long, style AV, 7 holes, short handled shovel.....	5 T. T.		
10			60	Strap, 15 inches long, style AVS, 7 holes, for pick mattock.....	5 T. T.	IV	9
30			180	Straps, cushion, 52 inches long, style DV, 10 holes.....	5 T. T.		
10			60	Shovel, short handled.....	5 T. T.	IV	10
1			6	Screw for steering clutch spring tool.....	5 T. T.		
1			6	Socket for steering clutch spring tool.....	5 T. T.		
10			60	Socket, square, "Mossberg".....	5 T. T.		
10			60	Socket, hexagonal, "Mossberg".....	5 T. T.		
10			60	do.....	5 T. T.		
10			60	do.....	5 T. T.		
10			60	do.....	5 T. T.		
10			60	do.....	5 T. T.		
10			60	do.....	5 T. T.		
10			60	Tube, long extension, "Mossberg".....	5 T. T.		
1			6	Wrench, spanner.....	5 T. T.		
1			6	do.....	5 T. T.		
1			6	Wrench, socket.....	5 T. T.		
10			60	Wrench for cylinder head stud nut.....	5 T. T.		
10			60	Wrench, spanner.....	5 T. T.		
10			60	Wrench for cylinder base stud nut.....	5 T. T.		
1			6	Wrench, socket.....	5 T. T.		
10			60	Wrench for thrust rod nut.....	5 T. T.		
10			60	Wrench, magneto.....	5 T. T.		
				<b>Tools and accessories for reel, model of 1909 ML.</b>			
1	4		10	Adjusting wrench.....	Reel.....	IV	9
1	4		10	Chain repair block.....	Reel.....		
1	4		10	Lock washer holder.....	Reel.....		
1	4		10	Tool wrapper, containing 1 screw driver, 1 socket wrench, 1 wrench, 0.5 and 0.375, 1 wrench, 0.75 and 0.625.....	Reel.....		
1	4		10	Lantern.....	Reel.....		
1	4		10	Lantern bracket pad.....	Reel.....		
1	4		10	Screw driver, 3-inch blade.....	Reel.....		
1	4		10	Screw driver, 10-inch blade.....	Reel.....		
1	4		10	Spanner for 56-inch wheel.....	Reel.....		
1	4		10	Lock washer, 14.5 inches long, 7 holes.....	Reel.....		
1	4		10	Lantern.....	Reel.....		
1	4		10	Spanner, 14.5 inches long, 7 holes.....	Reel.....		
1	4		10	Wrench, 12.5 inches long, 5 holes.....	Reel.....		
1	4		10	Oiler.....	Reel.....		
1	4		10	Seat cushion.....	Reel.....		
1	4		10	Wire guide.....	Reel.....		
				<b>Spare parts for reel.</b>			
1	4		10	Adjusting-ring lock.....	Reel.....	IV	3
2	8		20	Adjusting-ring lock screw.....	Reel.....		
2	8		20	Crown nut, 0.375-inch.....	Reel.....		
3	12		30	Crown nut, 0.5-inch.....	Reel.....		
2	8		20	Crown nut, 0.625-inch.....	Reel.....		
1	4		10	Drum latch brake shoe.....	Reel.....		
1	4		10	Drum latch pawl spring.....	Reel.....		
1	4		10	Drum latch plunger spring.....	Reel.....		

*Equipment for units composing a regiment of 155-mm. howitzer matériel, model of 1918  
(Schneider) motorized, on war footing—Continued.*

Number per organization.				Article.	Where carried.	Property classification.	
B.	H. C.	S. C.	R.			Class.	Division.
				<b>Spare parts for reel—Continued.</b>			
3	12		30	Handy oiler, 0.375-inch.....	Reel.....	IV	3
1	4		10	Oiler spring.....	Reel.....		
1	4		10	Pintle latch spring.....	Reel.....		
1	4		10	Roller chain 67.5 long, with cotter-pin connection link.....	Reel.....		
1	4		10	Roller chain 69.75 long with offset connecting link.....	Reel.....		
				Roller chain parts:			
1	4		10	Connecting link.....	Reel.....		
3	12		30	Cotter-pin connecting link.....	Reel.....		
3	12		30	Roller link, complete, common.....	Reel.....		
3	12		30	Offset connecting link.....	Reel.....		
6	24		60	Outside link, common.....	Reel.....		
				Split pins:			
6	24		60	0.093 ( $\frac{3}{32}$ ) by 1 inch.....	Reel.....		
10	40		100	0.125 by 1.25 inches.....	Reel.....		
3	12		30	0.156 ( $\frac{5}{32}$ ) by 1.5 inches.....	Reel.....		
1	4		10	0.25 by 1.25 inches.....	Reel.....		
2	8		20	Wheel, 56-inch, complete.....	A. S. T.....		
2	8		20	Wheel fastening.....	A. S. T.....		
1	4		10	Driving ring with pins.....	Cart.....		
8	32		80	Carriage bolt with nut.....	Cart.....		
1	4		10	Pintle with bearing complete, consisting of—			
				1 pintle.....	Cart.....		
				1 pintle latch.....	Cart.....		
				1 pintle latch pin with split pin.....	Cart.....		
				1 pintle latch spring.....	Cart.....		
				1 pintle bearing.....	Cart.....		
				1 pintle spring.....	Cart.....		
				1 pintle nut and split pin.....	Cart.....		
				2 trunnion bolts for pintle bearing.....	Cart.....		
				<b>Tools and accessories for cart, model of 1918.</b>			
1	4		10	Ax.....	Cart.....	IV	9
1	4		10	Hatchet, with handle.....	Cart.....		
1	4		10	Paulin, 12 by 12 feet.....	Cart.....		
1	4		10	Pickax with handle.....	Cart.....		
1	4		10	Picket rope.....	Cart.....		
1	4		10	Shovel, with long handle.....	Cart.....		
3	12		30	Watering buckets, canvas.....	Cart.....		
1	4		10	Dust guard (56-inch wheel).....	Cart.....		
1	4		10	Wireman's staff.....	Cart.....		
				Straps:			
1	4		10	Ax strap.....	Cart.....		
1	4		10	Bucket strap.....	Cart.....		
2	8		20	Paulin strap.....	Cart.....		
1	4		10	Pick handle strap.....	Cart.....		
1	4		10	Pick head strap.....	Cart.....		
3	12		30	Picket rope strap (upper).....	Cart.....		
3	12		30	Picket rope strap (lower).....	Cart.....		
1	4		10	Shovel handle strap.....	Cart.....		
2	8		20	Megaphone strap.....	Cart.....		
				<b>Spare parts for cart.</b>			
1	4		10	Adjusting link.....	Cart.....	IV	3
1	4		10	Adjusting nut.....	Cart.....		
2	8		20	Belleville springs.....	Cart.....		
1	4		10	Brake band body.....	A. S. T.....		
1	4		10	Brake pin (L=1.375).....	A. S. T.....		
1	4		10	Brake pin (L=2.25).....	A. S. T.....		
1	4		10	Bolt, 0.375 by 1.25 (brake lever shaft).....	Cart.....		
1	4		10	Bolt 0.375 by 1.406 ( $1\frac{1}{4}$ ) (brake segment rack).....	Cart.....		
1	4		10	Bolt 0.75 by 4.812 ( $4\frac{1}{4}$ ) (pintle).....	Cart.....		
2	8		20	Carrying spring.....	Cart.....		
2	8		20	Crown nuts 0.625.....	Cart.....		
2	8		20	Crown nuts 0.75.....	Cart.....		
2	8		20	Crown nuts 1.5.....	Cart.....		
1	4		10	Fastening lever.....	Cart.....		
1	4		10	Fastening spring.....	Cart.....		
1	4		10	Handy oiler, 0.375.....	Cart.....		
1	4		10	Lunette.....	A. S. T.....		
1	4		10	Lunette nut.....	A. S. T.....		

Equipment for units composing a regiment of 155-mm. howitzer matériel, model of 1918 (Schneider) motorized, on war footing—Continued.

Number per organization.				Article.	Where carried.	Property classification.	
B.	H. C.	S. C.	R.			Class.	Division.
				<b>Spare parts for cart—Continued.</b>			
1	4		10	Lunette lock washer.....	A. S. T.....	IV	3
				Split pins:			
1	4		10	0.125 by 1.25.....	Cart.....		
2	8		20	0.156 by 1.5.....	Cart.....		
1	4		10	0.203 by 1.25.....	Reel.....		
1	4		10	0.203 by 1.5.....	Reel.....		
1	4		10	0.203 by 2.25.....	Cart.....		
1	4		10	0.203 by 2.5.....	Reel.....		
1	4		10	0.25 by 2.75.....	Cart.....		
1	4		10	Washer.....	Cart.....		
1	4		10	Wing nut.....	Cart.....		
1	4		10	Wing nut pin.....	Cart.....		
				<b>Fire-control equipment.</b>			
				(Ordnance matériel.)			
2	4		16	B. C. telescope, model 1915, tripod, cases, and accessories.....	Cart.....	V	1
1	4		10	Aiming circle, tripod, and cases (model 1916).....	Cart.....		
1	4		10	Observation telescope monocular, tripod, and cases.....	Cart.....		
1	8		14	B. C. periscope, model 1918, tripod, and cases.....	Cart.....		
1	4		10	Range finder, 1-meter base, tripod, and cases.....	Cart.....		
2	4		16	Sitogoniometer and case.....	Cart.....		
2	4		16	Observation circle, with field glass support, tripod, and cases.....	Cart.....		
2	8		20	Prismatic compass, tripod, and cases, model of 1918.....	Cart.....		
2	4		16	Firing board, 50 by 76 cm., zinc covered, with waterproof cover.....	Cart.....		
2	4		16	Ruler, xylonite or zinc, 60 cm., graduated.....	Cart.....		
2	4		16	Protractor, zinc, semicircular, in mills.....	Cart.....		
2	8		20	Squares, zinc.....	Cart.....		
10	40		100	B. C. ruler, wooden, with string.....	Cart.....		
8	32		80	Strings, extra, for B. C. rulers.....	Cart.....		
1	8		14	Steel tape, 30 m.....	Cart.....		
1	4		10	Slide rule, model 1917, for solution of triangles, and case.....	Cart.....		
3	12		30	Time interval recorders, chains, and shock absorber.....	Cart.....		
5	20		50	Flash lights, with hoods.....	Cart.....	IV	9
16	64		160	Flash lights, without hoods.....	Cart.....		
12			72	Aiming posts.....	Cart.....		
2	4		16	Rocket board.....	Cart.....		
3	4		22	Jacob's staff and field-glass support.....	Cart.....		
4	8		32	Zinc sheets, 50 by 75 cm., for maps.....	Cart.....		
3	12		30	Protractor, celluloid, semicircular (model 1917).....	Cart.....		
16			96	Dry cells, No. 6, extra, for lighting device, and case.....	Cart.....		
2	8		20	Pick mattock and carrier (infantry).....	Cart.....		
30	120		300	Dry cells, batteries, for flash lights, and case.....	Cart.....		
				(Signal Corps matériel.)			
	2		2	Accumulators, 4-volt, 100 ampere hours.....	Tel. T. and W. T.....		
	2		2	Accumulators, 40-volt, 3 ampere hours.....	Tel. T. and W. T.....		
	1		1	Amplifiers, 3-terminal, French.....	Tel. T. and W. T.....		
	12		12	Batteries, dry, No. 6.....	Tel. T. and W. T.....		
6	16		52	Batteries, Eveready, No. 703, extra.....	Cart.....		
	8		8	Bells, vibrating, 50-ohm, or equivalent.....	Cart.....		
1	4		10	Carts, wire, hand (Brouette-Doroulense).....	Cart.....		
	25		25	Books, field message.....	Tel. T. and W. T.....		
1	3		9	Cases, battery.....	Tel. T. and W. T.....		
1	4		10	Climbers, with straps (pairs).....	Tel. T. and W. T.....		
8	24		72	Clips, testing, Muller Universal or Frankel.....	Tel. T. and W. T.....		
24	36		180	Fuzes, 1-ampere, for 4 and 12 line switchboards.....	Tel. T. and W. T.....		

*Equipment for units composing a regiment of 155-mm. howitzer matériel, model of 1918 (Schneider) motorized, on war footing—Continued.*

Number per organization.				Article.	Where carried.	Property classification.	
B.	H. C.	S. C.	R.			Class.	Division.
				<b>Fire-control equipment—Continued.</b>			
				(Signal Corps matériel)—Continued.			
8	26		74	Field glasses, Huet, 8-power (pairs).....	Tel. T. and W. T.		
4	10		34	Head sets, telephone.....	Tel. T. and W. T.		
100	100		700	Insulators, wooden knobs.....	Cart.		
12	65		137	Flag kits, combination, standard.....	Cart.		
3	8		26	Inspectors, pocket kit.....	Cart.		
4	12		36	Electricians' knives.....	Cart.		
2	4		16	Megaphones.....	Cart.		
100	100		700	Nails for insulators.....	Cart.		
	4		4	Panels, artillery type, white.....	Tel. T. and W. T.		
	4		4	Panels, artillery type, black.....	Tel. T. and W. T.		
2	8		20	Pliers, side cutting, 8-inch.....	Cart.		
	8		8	Poles, sectional bamboo (2 section, 2 M each).....	Tel. T. and W. T.		
	13		13	Projectors, 24 cm., with batteries.....	Tel. T. and W. T.		
1			6	Projectors, 14 cm., 3 in case, complete with batteries and cases.....	Cart.		
	5		5	Receiving set, artillery type, "A-1," complete (French).....	Tel. T. and W. T.		
	4		4	Switchboards, telephone, 12-line monotype.....	Tel. T. and W. T.		
2	8		20	Switchboards, telephone, 4-line monotype.....	Cart.		
3	8		26	Tape, friction, pounds.....	Cart.		
6	16		52	Telephone, Western Electric No. 1375-B.....	Cart.		
	25		25	Watches, wrist, luminous dial.....	Tel. T. and W. T.		
8	32		80	Wire, outpost, twisted pairs K/m.....	Reel		
3			18	Thermometer, Centigrade and Fahrenheit.....	Cart.		
				(Engineer Corps matériel.)			
1	4		10	Alidade, brass, open sight, leveling.....	R. C. and reel.		
	1		1	Alidade, miniature, telescopic, with declinator.....	Reel		
	3		3	Alidade, periscope.....	Reel		
1	4		10	Abney clinometer.....	Reel		
1	4		10	Clinometer, telescopic, with slide rule.....	Reel		
1	4		10	Plane table, 18 by 24 inches, tripod attachment, fiber case, waterproof cover.....	Reel and cart.		
2	8		20	Tripod, extension leg, Johnson movement, with case.....	Reel and cart.		
2	8		20	Declinator, with two clamp screws.....	Reel and cart.		
1	4		10	Drawing instruments (1 pair compasses, extra leg, drawing pen and proportional dividers).....	Reel and cart.		
1	4		10	Stadia rod, 10-foot, folding.....	Reel and cart.		
2	8		20	Plumb line.....	Reel and cart.		
3	12		30	Scales, plotting, 1/20,000 and millimeters.....	Reel and cart.		
1	4		10	Steel, arrow (tally pins, 10 in set).....	Reel and cart.		
1	4		10	Glass, magnifying, pocket.....	Reel and cart.		
1	4		10	Chests for topographic equipment.....	Reel and cart.		
1	4		10	Protractor, xylonite, rectangular.....	Reel and cart.		
20	80		200	Compass, watch.....	Reel and cart.		
10	40		100	Compass, marching.....	Reel and cart.		
1	8		14	Boards, sketching, with extension tripod.....	Reel and cart.		
1	8		14	Ruler, boxwood, triangular, 8-inch.....	Reel and cart.		
1	8		14	Tally machine.....	Reel and cart.		
1	8		14	Clinometer, reconnaissance.....	Reel and cart.		
12	96		168	Celluloid sheets.....	Reel and cart.		
1	8		14	Eraser, pencil, art gum.....	Reel and cart.		
2	16		28	Eraser, drawing, rubber.....	Reel and cart.		
1	8		14	Holders for timing pads.....	Reel and cart.		
1	8		14	Thumb tacks, box.....	Reel and cart.		
12	96		168	Pencils, drawing.....	Reel and cart.		
2	16		28	Pads, sketching.....	Reel and cart.		
4	32		56	Pads, timing.....	Reel and cart.		
12	96		168	Pencils, colored, assorted.....	Reel and cart.		
4	34		58	Protractors, pencil point.....	Reel and cart.		
2	16		28	Knife, steel eraser.....	Reel and cart.		
1	8		14	Pocket for pencils.....	Reel and cart.		
2	16		28	Tape, adhesive, rolls.....	Reel and cart.		
2	16		28	Sandpaper, pads.....	Reel and cart.		

Equipment for units composing a regiment of 155-mm. howitzer matériel, model of 1918  
(Schneider) motorized, on war footing—Continued.

Number per organization.				Article.	Where carried.	Property classification.	
B.	H. C.	S. C.	R.			Class.	Division.
				<b>Fire-control equipment—Continued.</b>			
				(Engineer Corps material)—Continued.			
1	4		10	Paper, drawing, single, 24 inches by 5 yards, roll, in japanned tube.	Reel and cart.		
1	8		14	Chest for sketching equipment.	Reel and cart.		
1	4		10	Alidade, boxwood, open sight.	Reel and cart.		
1	4		10	Plane table, 24 by 31 inches, tripod attachment, fiber case, waterproof cover.	Reel and cart.		
				<b>Miscellaneous equipment to be used in emergencies for converting caissons and carriage limbers into horse-drawn vehicles.</b>			
4			24	Bolts with crown nuts and split pins (carriage limber).	A. S. T.	IV	3
8			48	Chains, doubletree with open links (carriage limber).	A. S. T.		
4			24	Doubletrees (caisson).	A. S. T.		
4			24	Doubletrees (carriage limbers).	A. S. T.		
4			24	Doubletree adapters (caisson).	A. S. T.		
4			24	Keys (carriage limbers).	A. S. T.		
8			48	Pin, doubletree with crown nuts and split pins (carriage limber).	A. S. T.		
4			24	Pins, doubletree with crown nuts and split pins (caisson).	A. S. T.		
4			24	Pins, pole with split pins (caisson or carriage limber).	A. S. T.		
4			24	Poles, horse (caisson or carriage limber).	A. S. T.		
4			24	Pole sockets (caisson).	A. S. T.		
8			48	Straps, doubletree (carriage limber).	A. S. T.		
4			24	Neck yokes (caisson or carriage limber).	A. S. T.		
				<b>Contents of motor vehicle tool box carried on 2-ton Nash truck chassis, 2½-ton artillery tractors, and 5-ton artillery tractors.</b>			
26	16	12	184	Assembly, breaker, magneto (furnished by vehicle maker, to suit magneto used thereon).	M. B. T.	IV	9
26	16	12	184	Book, "Audel's Automobile Guide"	M. B. T.		
52	32	24	368	Batteries, extra, for flashlight, tungsten, American Eveready Co., No. 793.	M. B. T.		
26	16	12	184	Bulb, extra for flashlight, mazda, American Eveready Co., No. 1197.	M. B. T.		
26	16	12	184	Chain, towing, 15 feet long.	M. B. T.		
26	16	12	184	Chisel, cold, ½ by 6 inches.	M. B. T.		
26	16	12	184	Chisel, cold, ½ by 8 inches.	M. B. T.		
26	16	12	184	Chisel, cold, ½ by 6 inches.	M. B. T.		
26	16	12	184	Chisel, cold, ½ by 6 inches, diamond point.	M. B. T.		
26	16	12	184	Cover, canvas, for Ordnance handbooks.	M. T. B.		
26	16	12	184	Cover, canvas for "Audel's Automobile Guide"	M. T. B.		
26	16	12	184	Calcium carbide, 2-lb. can.	M. T. B.		
26	16	12	184	Drill, copper, ½ by 4 inches.	M. T. B.		
26	16	12	184	Drift, copper, ½ by 6 inches.	M. T. B.		
26	16	12	184	Drift, solid, ¼-inch point, 5.6 inches.	M. T. B.		
26	16	12	184	File, flat bastard, double cut, 10-inch.	M. T. B.		
26	16	12	184	File, half-round bastard, 10-inch.	M. T. B.		
26	16	12	184	File, square bastard, ¼-inch double cut, 10-inch.	M. T. B.		
26	16	12	184	File, ¼-inch, round bastard, 10-inch.	M. T. B.		
26	16	12	184	File, three cornered, ¼-inch, taper, single cut, second cut.	M. T. B.		
52	32	24	368	Files, magneto, "Disston's"	M. T. B.		
26	16	12	184	Flashlight, American Eveready, No. 1991, without rubber hood.	M. T. B.		
26	16	12	184	Gage, thickness, Starrett No. 72.	M. T. B.		
26	16	12	184	Gun, grease and oil, with two nozzles.	M. T. B.		
312	192	144	2,208	Gaskets, spark plug (furnished by vehicle maker, to fit spark plugs used thereon).	M. T. B.		
26	16	12	184	Hammer, ball pein, 12-ounce, standard handle, "Maydole" or equal.	M. T. B.		
26	16	12	184	Hammer, ball pein, 24-ounce, standard handle, "Maydole" or equal.	M. T. B.		
26	16	12	184	Hammer, soft babbitt.	M. T. B.		
26	16	12	184	Jack-screw, "Vulcan," size 1½ by 10-inch, 10-ton capacity, with bar.	M. T. B.		

Equipment for units composing a regiment of 155-mm. howitzer materiel, model of 1918 (Schneider) motorized, on war footing—Continued.

Number per organization.				Article.	Where carried.	Property classification.	
B.	H. C.	S. C.	R.			Class.	Division.
				<b>Contents of motor vehicle tool box carried on 2-ton Nash truck chassis, 2-ton artillery tractors, and 5-ton artillery tractors—Continued.</b>			
52	32	24	368	Oilers, dome type.....	M. T. B.	X	10
26	16	12	184	Fuller and spreader, cotter pin, $\frac{1}{2}$ by $6\frac{1}{2}$ inches, "Bay State".....	M. T. B.		
26	16	12	184	Pins, cotter, box assorted.....	M. T. B.	X	9
26	16	12	184	Pliers, pair of 8-inch combination gas.....	M. T. B.		
26	16	12	184	Pliers, pair of 6-inch round nose.....	M. T. B.	X	10
26	16	12	184	Pliers, pair of 8-inch wire cutting.....	M. T. B.		
26	16	12	184	Pinchbar, 27-inch.....	M. T. B.	X	10
26	16	12	184	Punch center, $4\frac{1}{2}$ inches long, "Bay State".....	M. T. B.		
104	64	48	736	Plugs, spark (furnished by vehicle maker; same kind as used on engine).....	M. T. B.	X	10
26	16	12	184	Rule, folding, steel, 12 inches long, "Starrett" No. 450, M. & E.....	M. T. B.		
52	32	24	368	Shackles, standard, round pin, drop-forged steel, Anchor Style, size $\frac{1}{2}$ -inch, H. Channon Co., No. 213.....	M. T. B.	X	9
26	16	12	184	Scrapers, carbon, set of three.....	M. T. B.		
26	16	12	184	Screw driver, 3-inch blade.....	M. T. B.	X	10
26	16	12	184	Screw driver, all-steel, 9-inch, "Channon".....	M. T. B.		
26	16	12	184	Screw driver, offset, 6 inches, straight handle, "Channon".....	M. T. B.	IV	9
26	16	12	184	Sledge, model 1907.....	M. T. B.		
52	32	24	368	Tape, friction, $\frac{1}{2}$ inch, $\frac{1}{2}$ pound rolls.....	M. T. B.	X	10
52	32	24	368	Tips, lava, $\frac{1}{2}$ cubic foot per hour, for gas search-light burner.....	M. T. B.		
26	16	12	184	Wrenches, monkey, 6 inches long, steel handle, "Trimo".....	M. T. B.	X	10
26	16	12	184	Wrenches, monkey, 15-inch, steel handle, "Trimo".....	M. T. B.		
26	16	12	184	Wrenches, pipe, 6-inch, steel handle, "Trimo".....	M. T. B.	X	10
26	16	12	184	Wrenches, pipe, 10-inch, steel handle, "Trimo".....	M. T. B.		
26	16	12	184	Wrenches, adjustable, "S," 6-inch, Wescott pattern.....	M. T. B.	X	10
26	16	12	184	Wrenches, adjustable "S," 10-inch, Wescott pattern.....	M. T. B.		
26	16	12	184	Wrenches, spark plug (furnished by vehicle maker to suit type of plugs with which vehicle is equipped).....	M. T. B.	IV	9
26	16	12	184	Wrenches, double-end $\frac{1}{2}$ and $\frac{3}{4}$ inch milled openings. William's No. 721, semifinished.....	M. T. B.		
52	32	24	368	Wrenches, double-end $\frac{1}{2}$ and $\frac{3}{4}$ inch milled openings. William's No. 23, semifinished.....	M. T. B.	IV	9
52	32	24	368	Wrenches, double-end $\frac{1}{2}$ and $\frac{3}{4}$ inch milled openings. William's No. 725-A, semifinished.....	M. T. B.		
52	32	24	368	Wrenches, double-end $\frac{1}{2}$ and $\frac{3}{4}$ inch milled openings. William's No. 27, semifinished.....	M. T. B.	IV	9
26	16	12	184	Wrenches, double-end $\frac{1}{2}$ and $\frac{3}{4}$ inch milled openings. William's No. 729, semifinished.....	M. T. B.		
26	16	12	184	Wrenches, double-end, $\frac{1}{2}$ and $\frac{3}{4}$ inch milled openings. William's No. 731-B, semifinished.....	M. T. B.	IV	9
26	16	12	184	Wrenches, double-end $\frac{1}{2}$ and $\frac{3}{4}$ inch milled openings. William's No. 32, semifinished.....	M. T. B.		
26	16	12	184	Wrenches, double-end $\frac{1}{2}$ and $\frac{3}{4}$ inch milled openings. William's No. 33-C, semifinished.....	M. T. B.	IV	9
26	16	12	184	Wrenches, double-end, $1\frac{1}{2}$ and $1\frac{3}{4}$ inch milled openings. William's No. 737, semifinished.....	M. T. B.		
26	16	12	184	Wrenches, double-end $1\frac{1}{2}$ and $1\frac{3}{4}$ inch milled openings. William's No. 38, semifinished.....	M. T. B.	IV	9
26	16	12	184	Waste, white cotton, pound.....	M. T. B.		
26	16	12	184	Wire, copper, No. 16 B. & S., spool.....	M. T. B.	X	10
26	16	12	184	Wire, soft steel, No. 16 B. & S., spool.....	M. T. B.		
260	160	120	1,840	Washers, lock, S. A. E., heavy, $\frac{1}{2}$ -inch.....	M. T. B.	X	10
260	160	120	1,840	Washers, lock, S. A. E., heavy, $\frac{3}{4}$ -inch.....	M. T. B.		
260	160	120	1,840	Washers, lock, S. A. E., heavy, $\frac{1}{2}$ -inch.....	M. T. B.	X	10
260	160	120	1,840	Washers, lock, S. A. E., heavy, $\frac{3}{4}$ -inch.....	M. T. B.		
260	160	120	1,840	Washers, lock, S. A. E., heavy, $\frac{1}{2}$ -inch.....	M. T. B.	X	10
260	160	120	1,840	Washers, lock, S. A. E., heavy, $\frac{3}{4}$ -inch.....	M. T. B.		
260	160	120	1,840	Washers, lock, S. A. E., heavy, $\frac{1}{2}$ -inch.....	M. T. B.	X	10
260	160	120	1,840	Washers, lock, S. A. E., heavy, $\frac{3}{4}$ -inch.....	M. T. B.		

<sup>1</sup> Carried on tractors only.

<sup>2</sup> Not carried on tractors.

## INDEX.

A.	Page.
Accessories and tools.....	58
Adapters and boosters.....	30
Axle traveling lock.....	56
Adjustment of sights.....	151
Additional tests.....	152
Verification and adjustment of sights in the field.....	153
Verification and adjustment of the peep sight.....	153
Air pump.....	58
Ammunition:	
The primer.....	25
The cartridge.....	25
Common steel shell, Mark I.....	26
Gas shell, Mark II.....	26
Common steel shell, Mark IV.....	26
Semisteel shell, Mark XVII.....	27
Shrapnel.....	27
Fuzes.....	28
Adapters and boosters.....	30
Packing ammunition for shipment.....	34
Ammunition truck:	
General weights, dimensions and outline specifications of body.....	102
Brief description of ammunition truck body.....	102
Weights and outline specifications of all 2-ton chassis, Nash models.....	102
Brief description of chassis.....	103
Chassis equipment.....	169
Body equipment.....	170
Contents of motor vehicle tool box.....	207
Anti-aircraft machine-gun:	
Weights and dimensions.....	90
General description.....	90
Anti-aircraft machine-gun mount, cygnet type.....	91
Anti-aircraft machine-gun tripod, model of 1918.....	92
Browning machine-gun tripod, model of 1917.....	93
Anti-aircraft machine-gun mount, signet type.....	91
Anti-aircraft machine-gun tripod.....	92
Anti-aircraft machine-gun trailer:	
Principal dimensions and outline specifications.....	104
General description.....	104
Artillery repair truck:	
Weights and specifications.....	105
General description.....	105
Body equipment.....	187
Body attachments.....	187
Load.....	189

Artillery supply truck:	Page.
General weights and dimensions.....	107
Brief description.....	107
Body equipment.....	171
Load A.....	171
Load B-I.....	175
Load C.....	183
Load D.....	184
Artillery tractor, 2½-ton:	
Weights and dimensions.....	97
Brief description.....	98
Equipment.....	202
Contents of motor vehicle tool box.....	207
Artillery tractor, 5-ton:	
Weights and dimensions.....	99
Brief description.....	100
Outline specifications.....	100
Equipment.....	202
Contents of motor vehicle tool box.....	207
B.	
Breech mechanism.....	16
Browning machine gun.....	90
Browning machine gun tripod.....	93
C.	
Caisson:	
Weights and principal dimensions.....	78
Nomenclature of parts.....	78
Description of the caisson.....	85
Spare parts.....	168
Tools and accessories.....	167
Care, maintenance, and operation of matériel.....	129
Care and maintenance of the matériel:	
Oils and greases.....	129
Care of the howitzer.....	130
Care of the carriage and other vehicles.....	131
Care of the sights.....	139
Carriage:	
Weights and principal dimensions.....	35
Nomenclature of parts.....	36
Description of the carriage.....	51
The sleigh.....	51
The cradle.....	52
Recoil and counter-recoil mechanisms.....	53
Trail.....	53
Elevating mechanism.....	55
Traversing mechanism.....	55
Axle traveling lock.....	56
The wheels.....	56
The shield.....	57
Road brake.....	57
Tools and accessories.....	162
Spare parts.....	165

	Page.
Carriage limber.....	73
Carriage and other vehicles, the care of:	
To grease limber and caisson wheels.....	132
Daily inspection.....	135
Cartridge, the.....	25
Cart:	
Weights and principal dimensions.....	119
Nomenclature of parts.....	120
Description.....	124
Tools and accessories.....	204
Spare parts.....	204
Cleaning materials.....	125
Clock oil.....	125
Counter-recoil and recoil mechanisms.....	53
Counter-recoil and recoil mechanisms, care of the:	
To measure the pressure and liquid.....	133
To add gas.....	134
To add liquid.....	134
Cradle.....	52
D.	
Daily inspection.....	135
Description of the caisson:	
The chest.....	85
Spring supporting mechanism.....	87
The road brake.....	88
The wheels.....	88
The reel.....	89
Description of the carriage.....	51
Description of the howitzer.....	15
Description of the limber:	
The frame.....	75
The pole socket and pole.....	77
Wheels.....	77
Drag rope.....	61
Duties of the battery mechanics:	
The howitzer.....	139
To dismantle the breech mechanism.....	140
To assemble the breech mechanism.....	140
Preparation of the liquid for the recoil and counter-recoil cylinders.....	141
Repairs and replacements.....	142
To dismount the firing mechanism.....	142
To assemble the firing mechanism.....	142
To dismount the elevating mechanism.....	143
To assemble the elevating mechanism.....	144
To dismount the traversing rollers.....	144
To assemble the traversing rollers.....	144
To dismount the traversing mechanism and axle.....	145
To assemble the traversing mechanism and axle.....	146
To dismount the axle traveling lock.....	147
To assemble the axle traveling lock.....	147
To dismount the spade.....	148

Duties of the battery mechanics—Continued.	Page.
To assemble the spade.....	148
To dismantle the brake rigging.....	148
To assemble the brake rigging.....	149
To remove the brake band from the caisson.....	149
To replace the brake band.....	149
To remove supporting springs from the caisson.....	150
To replace the supporting springs.....	150
To remove the axle bracket.....	150
To replace the axle bracket.....	150
<b>Duties of the gun crew:</b>	
To dismantle the firing mechanism.....	136
To assemble the firing mechanism.....	136
Dismantling the percussion mechanism.....	136
Assembling the percussion mechanism.....	136
Dismounting the cradle traveling lock.....	137
Assembling the cradle traveling lock.....	137
Dismounting the sleigh traveling lock.....	137
Assembling the sleigh traveling lock.....	137
Removing a carriage wheel.....	137
Replacing the wheel.....	137
Removing the caisson connecting pole.....	137
Replacing the caisson connecting pole.....	138
Dismounting the pintle.....	138
Assembling the pintle.....	138
Removing a caisson wheel.....	138
Replacing the wheel.....	138
Removing a limber wheel.....	138
Replacing the wheel.....	139
<b>E.</b>	
Equivalents, table of.....	11
Elevating mechanism.....	55
Engine oil No. 1.....	125
<b>Equipment:</b>	
List of equipment.....	161
Table of units composing a regiment.....	162
<b>F.</b>	
Filling pipes.....	60
<b>Fire-control equipment:</b>	
Ordnance matériel.....	205
Signal corps matériel.....	205
Engineer Corps matériel.....	206
Firing mechanism.....	17
Funnel.....	61
Funnel pipes.....	61
<b>Fuzes:</b>	
45-second combination fuze.....	28
Point detonating fuze, Mark IV.....	32
Point detonating fuze, Mark III.....	33
Hand fuze setter.....	33

## G.

	Page.
General description of the 155-mm. howitzer matériel.....	12
General information:	
Painting artillery matériel.....	156
Instructions for riveting.....	157
Cleaning and disinfecting matériel affected by gas.....	158
Repairs for field artillery matériel.....	160
General notes on caring for the matériel.....	154
Glycerin and water.....	126
Grease.....	125
Graphite.....	125
Gunner's quadrant.....	70

## H.

Hand fuze setter.....	33
Howitzer:	
Weights, principal dimensions, etc.....	14
Nomenclature of parts.....	14
Description of the howitzer.....	15
The breech mechanism.....	16
The firing mechanism.....	17
Percussion mechanism.....	18
Operation of the breech mechanism.....	19
Misfires.....	20
Table showing spare and replacement parts.....	21
Table showing spare and reserve parts.....	22
Table showing interchangeability of spare and replacement parts.....	23
Tools and accessories.....	162
Spare parts.....	163
Howitzer caisson.....	78
Howitzer in battery.....	129
Howitzer, care of the.....	130
Howitzer carriage limber.....	73
Howitzer in traveling position.....	129
Hydroline.....	126

## I.

Inspection by battery mechanics.....	153
Instructions for the care, maintenance, and operation of the matériel:	
Maneuvering the carriage.....	129
Care and maintenance of the matériel.....	129
Care of the howitzer.....	130
Care of the carriage and other vehicles.....	131
Instructions for repairs and replacements:	
Duties of the gun crew.....	136
Duties of the battery mechanics.....	139

## K.

Kerosene (coal oil).....	127
--------------------------	-----

## L.

Light repair truck:	
Weights, dimensions, etc.....	109
Brief description of chassis.....	109
Brief description of truck body.....	110

Light repair truck—Continued.	Page.
Chassis equipment.....	195
Body equipment.....	196
Load.....	196
Limber:	
Weights and principal dimensions.....	73
Nomenclature of parts.....	73
Description of the limber.....	75
Spare parts.....	167
Tools and accessories.....	167
List of plates.....	10
Liquid pump.....	59
Loading barrow.....	61
Lubricants.....	125
M.	
Maneuvering the carriage:	
Howitzer in traveling position.....	129
Howitzer in battery.....	129
Measure.....	61
Misfires:	
Missing of the primer.....	20
Missing of the charge.....	20
N.	
Night lighting equipment.....	71
O.	
Operation of the breech mechanism:	
To open the breech.....	19
To close the breech.....	19
Oils, lubricants, and cleaning materials.....	125
Operation of the matériel.....	129
P.	
Packing ammunition for shipment.....	34
Panoramic sight.....	66
Nomenclature of parts.....	67
Use of the panoramic sight.....	67
Peep sight.....	68
Percussion mechanism.....	18
Plates, list of.....	10
Pressure-gage adapter.....	59
Pressure gage.....	60
Primer, the.....	25
Q.	
Quadrant sight.....	63
Nomenclature of parts.....	65
R.	
Rammer.....	62
Recoil and counterrecoil mechanisms.....	53
Recoil and counterrecoil mechanisms, care of the.....	132

	Page.
<b>Reconnaissance car:</b>	
Weights, principal dimensions, etc.....	96
Brief description.....	97
Chassis equipment.....	200
Body equipment.....	201
<b>Reel:</b>	
Weights and principal dimensions.....	111
Nomenclature of parts.....	111
Description of the reel.....	117
Tools and accessories.....	203
Spare parts.....	203
<b>Repairs and replacements:</b>	
Duties of the gun crew.....	136
Duties of the battery mechanics.....	139
Reservoir for compressed gas.....	59
Retracting rope and tackle block.....	62
Road brake.....	57
<b>S.</b>	
<b>Shells:</b>	
Common steel shell, Mark I.....	26
Gas shell, Mark II.....	26
Common steel shell, Mark IV.....	26
Semisteel shell, Mark XVII.....	27
Shrapnel.....	27
Shield, the.....	57
<b>Sights:</b>	
The quadrant sight.....	63
The panoramic sight.....	66
The peep sight.....	68
The sight extension.....	69
Gunner's quadrant.....	70
Night lighting equipment.....	71
Care of the sights.....	139
Verification and adjustment.....	151
Sight equipment.....	169
Spare parts.....	169
Sight extension.....	69
Sighting staff.....	62
Sleigh, the.....	51
Slush brush.....	62
Slushing oils.....	127
Sponge.....	62
Staff.....	62
<b>Staff observation car:</b>	
Table of weights and outline specifications.....	93
Brief description of the body.....	94
Brief description of the chassis.....	95
Chassis equipment.....	199
Body equipment.....	200

## T.

	Page.
Table of equivalents.....	11
Table showing spare and replacement parts for 155-mm. howitzer.....	21
Table showing spare and reserve parts for 155-mm. howitzer.....	22
Table showing interchangeability of spare and replacement parts for 155-mm. howitzer.....	23
Tools and accessories:	
Air pump.....	58
Liquid pump.....	59
Reservoir for compressed gas.....	59
Pressure gage adapter.....	59
The filling pipes.....	60
Pressure gage.....	60
Loading barrow.....	61
Wheel mats.....	61
Drag rope.....	61
Funnel measure and funnel pipe.....	61
Sponge, staff, and slush brush.....	62
Rammer.....	62
Sighting staff.....	62
Retracting rope and tackle block.....	62
Trail.....	53
Traversing mechanism.....	55

## U.

Use of the gunner's quadrant.....	70
Use of the panoramic sight:	
For direct fire.....	67
For indirect fire.....	68
Use of the peep sight.....	69

## V.

Verification and adjustment of the sights:	
Additional tests.....	152
Verification and adjustment of the sights in the field.....	153
Verification and adjustment of the peep sight.....	153

## W.

Wheels, the.....	56
Wheel mats.....	61

WAR DEPARTMENT,

OFFICE OF THE CHIEF OF ORDNANCE,

Washington, December 14, 1918.

Form No. 2017.

[The page contains extremely faint and illegible text, likely bleed-through from the reverse side of the document. The text is scattered across the page and cannot be transcribed accurately.]



[The page contains extremely faint and illegible text, likely bleed-through from the reverse side of the document. The text is scattered across the page and cannot be transcribed accurately.]



Vertical line on the left side of the page.





3 2044 010 168 508

**THE BORROWER WILL BE CHARGED  
AN OVERDUE FEE IF THIS BOOK IS  
NOT RETURNED TO THE LIBRARY ON  
OR BEFORE THE LAST DATE STAMPED  
BELOW. NON-RECEIPT OF OVERDUE  
NOTICES DOES NOT EXEMPT THE  
BORROWER FROM OVERDUE FEES.**

**Harvard College Widener Library  
Cambridge, MA 02138 (617) 495-2413**

