

11. Advances (ex)

No. 1798

**HANDBOOK OF THE
8-INCH HOWITZER MATÉRIEL**

MODEL OF 1917 (VICKERS MARK VI)

WITH INSTRUCTIONS FOR ITS CARE

TWENTY-THREE PLATES

JANUARY 15, 1918



WASHINGTON
GOVERNMENT PRINTING OFFICE
1918

(Form No. 1798.)

The Commanding Officer or the Post or Coast Defense Ordnance Officer to whom this copy is issued will be held personally responsible for its safe-keeping. When another officer relieves him a receipt for it will be taken, which should be mailed to the CHIEF OF ORDNANCE, U. S. Army, Washington, D. C.

NOTE.—This pamphlet may be destroyed when superseded by one of later date.

(2)

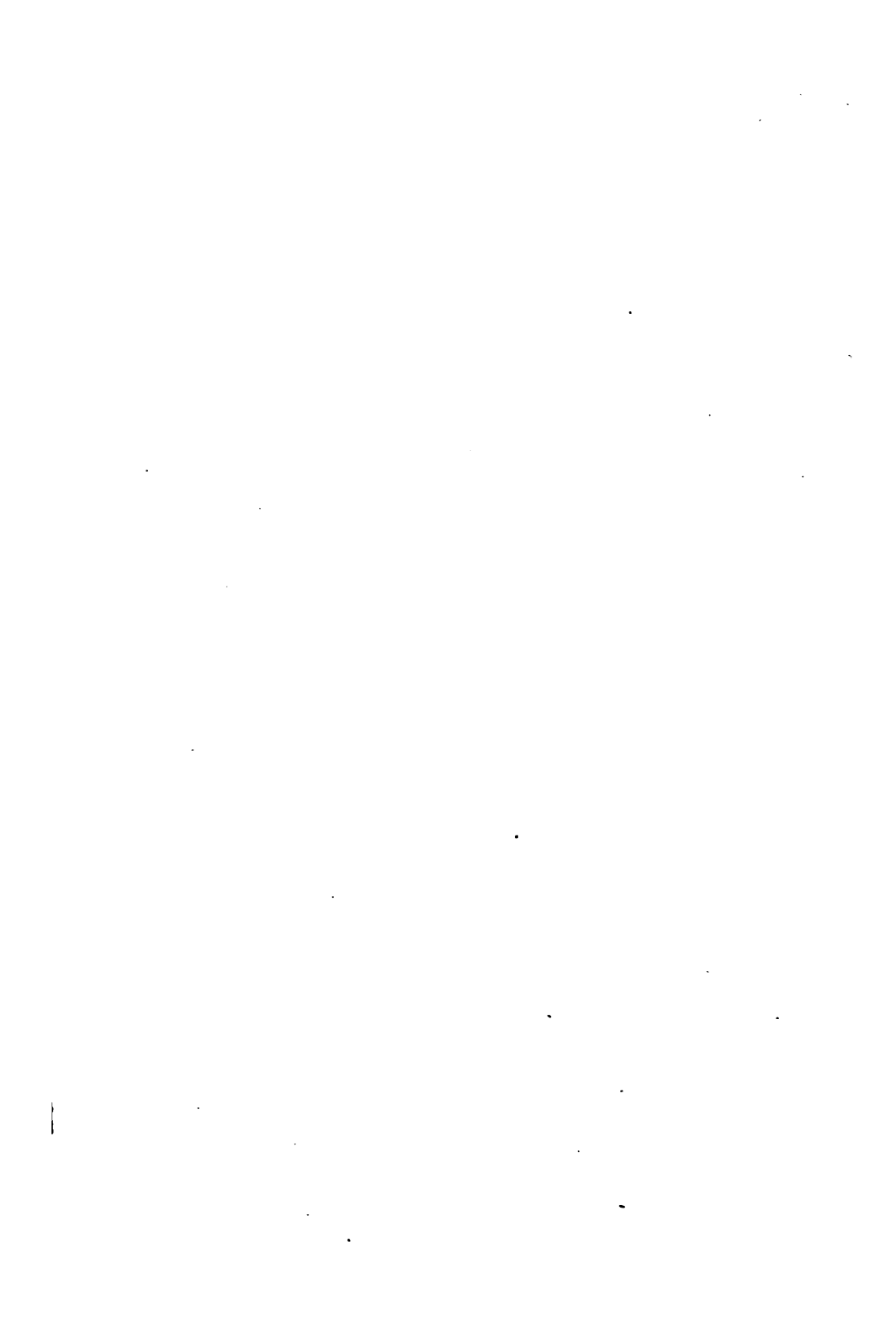

LIST OF CONTENTS.

	Page.
List of plates.....	6
List of equipment pertaining to one 8-inch howitzer battery on war footing.....	7
8-inch howitzer, model of 1917 (Vickers Mark VI).....	7-14
Table of weights, dimensions, etc.....	7
Description of the howitzer.....	8
Breech mechanism.....	9
Obturation.....	10
Firing mechanism.....	11
To remove breech mechanism.....	12
Care and preservation of howitzer and breech mechanism..	14
Ammunition.....	15
General remarks.....	15
Primer.....	15
The cartridge.....	16
Additional powder increments.....	16
The common steel shell.....	17
The fuze.....	17
Packing for shipment.....	18
Misfires and hangfires.....	19
8-inch howitzer carriage, model of 1917 (Vickers Mark VI).....	19
Weights, dimensions, etc.....	19
Description.....	19
Care and preservation of the carriage.....	26
Sighting gear.....	37
Sight-operating gear.....	38
Sight, rocking bar.....	38
Clinometer sight.....	39
Dial sight.....	40
Panoramic sight, model of 1917.....	40
Description.....	40-46
Nomenclature of parts.....	46
Testing and adjusting sights.....	47
8-inch howitzer firing platform, model of 1917 (Vickers).....	50
Description.....	50-53
8-inch howitzer carriage limber, model of 1917 (Vickers).....	57
Description.....	57
Miscellaneous tools and accessories.....	58
Fire-control instruments, table of.....	60
Table of equipment.....	60-68

LIST OF PLATES.

	Page.
I. 8-inch howitzer, model of 1917 (Vickers Mark VI).....	8
II. 8-inch howitzer, model of 1917 (Vickers Mark VI), breech mechanism, sections.....	10
IIA. 8-inch howitzer, model of 1917 (Vickers Mark VI), breech mechanism.....	11
III. 8-inch howitzer, model of 1917 (Vickers Mark VI), firing mechanism.....	12
IV. 21-grain percussion primer, Mark II.....	15
V. Powder charge, 8-inch howitzer, model of 1917 (Vickers Mark VI).....	16
VI. 8-inch common steel shell, Mark I.....	17
VII. Point detonating fuze, Mark II.....	18
VIII. 8-inch howitzer carriage, model of 1917 (Vickers Mark VI), assembly.....	19
IX. 8-inch howitzer carriage, model of 1917 (Vickers Mark VI), plan.....	20
X. Brake.....	21
XI. Elevating, traversing, and sight-operating gear.....	22
XII. Quick-loading gear.....	23
XIII. Recoil cylinder and recuperator, section.....	25
XIV. Variable recoil gear.....	26
XV. Sight, assembly.....	38
XVI. Sighting arrangement, section.....	39
XVII. Panoramic sight, model of 1917.....	42
XVIII. Target for testing sights.....	48
XIX. Air compressor, sections.....	50
XX. Howitzer and carriage on firing platform.....	51
XXI. Traveling arrangement.....	52
XXII. Firing platform.....	53
XXIII. Platform wagon.....	56

LIST OF EQUIPMENT PERTAINING TO ONE 8-INCH HOWITZER BATTERY ON WAR FOOTING.

Number.	Equipment.
4 ¹	8-inch howitzer, model of 1917 (Vickers Mark VI).
4 ¹	8-inch howitzer carriage, model of 1917 (Vickers Mark VI), complete with sight gear, panoramic sight, dial sight, and range quadrant.
4 ¹	8-inch howitzer carriage limber, model of 1917.
4 ¹	8-inch howitzer firing platform, model of 1917.
4 ²	120-horsepower tractor (20-ton).
12 ²	Ammunition-carrying truck.
8 ²	3-ton truck (personnel).
2 ²	Supply truck.
2 ²	Tool truck (ammunition type).
1 ²	Artillery supply truck.
1 ²	Artillery repair truck.
1 ²	Tank truck (gasoline).
3	5-passenger automobile.
12	Motorcycle, with side car.
1	Kitchen, rolling trail.
1	Reconnaissance car.
1 ³	Reel truck, model of 1918.
1	Telephone truck.

¹ Information regarding this matériel only is contained in this handbook.

² Description, etc., regarding these vehicles is given in special handbooks of motor equipment.

³ Description, etc., regarding the truck is given in the Handbook of Fire-Control Equipment.

8-INCH HOWITZER, MODEL OF 1917 (VICKERS MARK VI).

Table of weights, dimensions, etc.

Weight (including breech mechanism).....	pounds.	6,552
Caliber.....	inches..	8
Total length.....	do.,...	127.6
Length of bore.....	do.....	117.7
Length of rifle portion of bore.....	do.....	102.11
Number of grooves.....		48
Width of grooves.....	inch..	.349
Depth of groove.....	do.....	.06
Width of lands.....	do.....	.1745
Twist, in calibers, uniform 1 in 15, right-hand.		

Powder chamber:

Diameter.....	inches..	8.5
Length.....	do....	12.74
Capacity.....	cubic inches..	750
Total capacity of bore.....	do....	6,130
Weight of projectile.....	pounds..	200
Obturation.....		Pad.
Firing mechanism.....		Percussion.

The principal difference between the Mark VI howitzer and the Mark VII howitzer is that the Mark VII howitzer is longer and heavier than the Mark VI howitzer. The Mark VII howitzer is wire wrapped, while the Mark VI howitzer is of built-up construction. The chamber capacity of the Mark VII howitzer is greater, thus giving a longer range. The principal ballistic differences are given in the following comparative table.

	Mark VI.	Mark VII.
Weight of powder charge.....	10 pounds 12 ounces (approximately).	16 pounds (approx).
Powder charge, number of increments.....	4	6
Maximum muzzle velocity, feet per second..	1,300	1,525
Maximum range.....yards..	10,500	12,100

DESCRIPTION OF THE HOWITZER.

(Plate I.)

The howitzer is of steel and consists of a tube, jacket, breech bushing, rear guide ring, breech ring, and front guide ring with stop plate. The tube extends from the seat of the obturator to the muzzle. The jacket is shrunk over the tube and is secured longitudinally by means of corresponding shoulders on the tube and jacket, also by the breech bushing which is screwed into the rear end; the breech bushing is also prepared for the reception of the breechblock. Over a portion of the jacket toward the rear and extending over the chamber and a portion of the bore, is shrunk the rear guide ring, which is furnished on the underside with two projections with bronze liners, which serve as guides for the howitzer when in the cradle. The breech ring is shrunk over the rear end of the jacket and rear guide ring and screwed to the former. The front guide ring, which is furnished with guides with bronze liners fitting the guideways on top of the cradle of the carriage, is shrunk over the jacket along the chase; it carries a spring

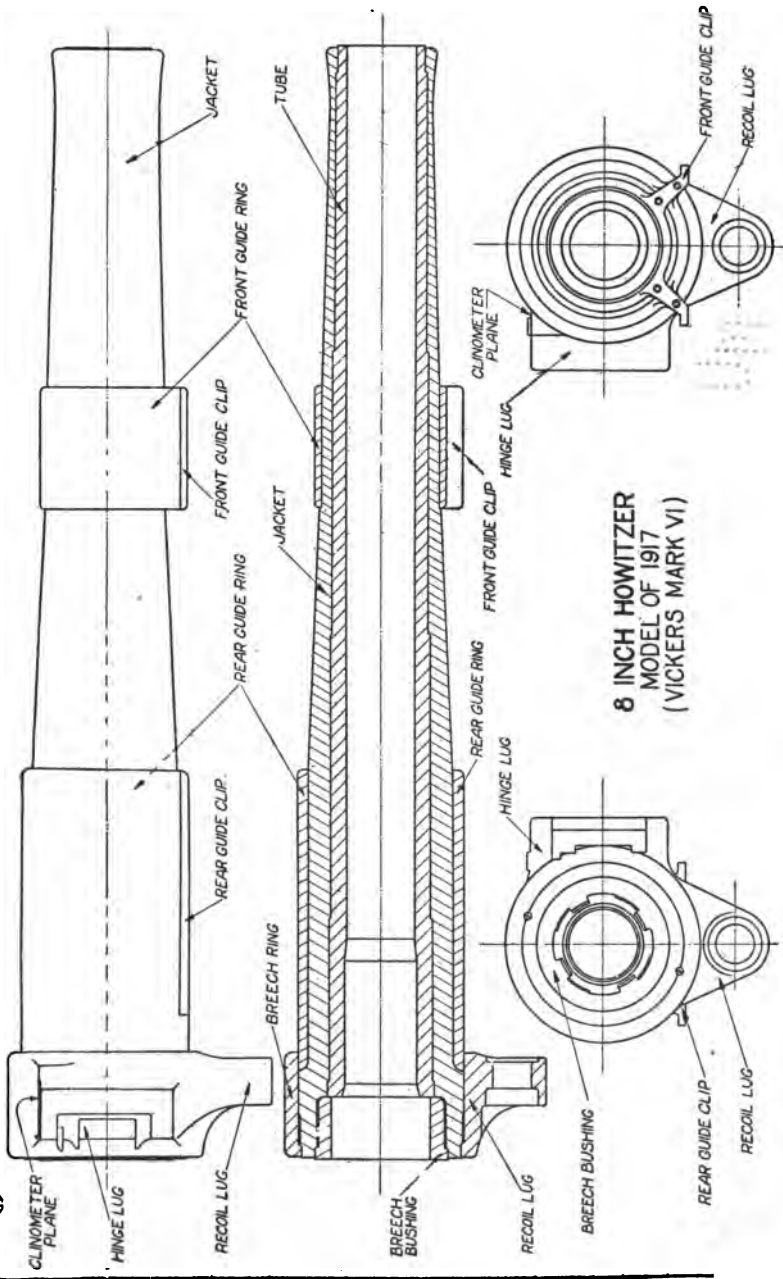

1111
1112
1113
1114
1115
1116
1117
1118
1119
1120



plunger on the left side, which serves as a reader for the recoil scale on the cradle. A steel stop plate is attached to the front face of the guides by four screwed rivets.

The breech ring is prepared for the reception of the breech mechanism and provided on the underside with a lug for the attachment of the body of the hydraulic buffer and recuperator of the carriage. Securing screws are provided in the breech face to prevent the breech ring from turning when in position.

Right and left gun-metal dust covers with securing screws connect the front and rear guides.

The chamber is cylindrical, coned at the entrance and reduced in diameter at the front end.

A plane for a clinometer is prepared on the right upper side of the breech ring.

Axis lines are cut on the upper side and on the horizontal axis at the breech and muzzle ends. Fine horizontal and vertical axis lines are also cut on the breech and muzzle faces.

The actual weight of the howitzer (without breech mechanism) is engraved on top of the breech ring, and a line, denoting center of gravity (without mechanism), is cut transversely on the upper side of the jacket immediately in front of the rear guide ring.

The type, mark, register number, manufacturer's initials, and year of manufacture are engraved on the upper portion of the breech face.

BREECH MECHANISM.

(Plate II and IIA.)

The breechblock is worked by means of an operating lever on the right side of the breech. On pulling the lever to the rear the breechblock is automatically unlocked and swung into the loading position. After loading, one thrust on the same lever inserts the breechblock and turns it into the locked position.

The breechblock is of the interrupted screw type. It is divided circumferentially into 12 equal parts, 4 of which are plain and the remaining 8 screw-threaded, thus giving a two-thirds bearing surface to the breechblock in the locked position. The threaded sectors are of different diameters, the breech recess of the howitzer having complementary threaded sectors to receive them. The interruptions in the howitzer are arranged to accommodate the sectors of the block of largest diameter; thus, when the block is unlocked, these sectors pass into the interruptions and the sectors smaller in diameter unlock into the spaces left vacant by those of the larger diameter.

The interior of the block is recessed to fit over a pintle on the front of the carrier, and is bored through its center for the reception of the obturation spindle.

The breechblock is supported when withdrawn by a bronze carrier hinged to the right side of the breech ring, the dead weight of the mechanism being taken on a bronze washer between the carrier and the bottom lug on the breech ring. Upon the front of the carrier is a pintle forming a pivot for the breechblock which is secured thereon by means of a retaining plate and an eccentric actuating pin in the rear end of the breechblock, so arranged as to admit of the breechblock being revolved through one-twelfth of a circle on the pintle in locking and unlocking.

By depressing the eccentric pin against a spring, it can be rotated through 180°, the plate being thus drawn back flush with the hole in the breechblock, for assembling or dismantling.

This arrangement also permits of the carrier being withdrawn independently of the breechblock, should the latter become fast in the breech.

A recess for a crosshead is provided in the right side of the breechblock. The crosshead is actuated by means of a crank and breech-operating lever in the carrier so as to revolve the block in locking and unlocking. A roller with axis pin on the rear face of the breechblock, and a cam on the breech end, are also provided, to give a turning movement to the breechblock in closing.

Secured to the hinge side of the breech face is a control arc over which one sector of the breechblock rides as the mechanism is swung into loading position, and prevents the breechblock rotating. The arc may also be used as a friction brake by pressing upward on the lever, to control the swing out of the breech mechanism when opening the breech at different angles of elevation. The weight of the breech mechanism holds it in the open position.

The breech-operating lever is retained in the closed position by means of a catch in the lever, which engages a steel catch plate in the carrier. The catch is disengaged by a downward pressure on lug on side of hand lever before same can be pulled to the rear.

OBTURATION.

(Plate II.)

The obturator pad is supported on the obturator spindle, and is held tightly between the mushroom head of the latter and the front end of the breechblock by a spring and nut. It consists of asbestos wool up in mutton suet to a proper consistency, inclosed in a strong canvas cover and pressed into shape in a hydraulic machine.

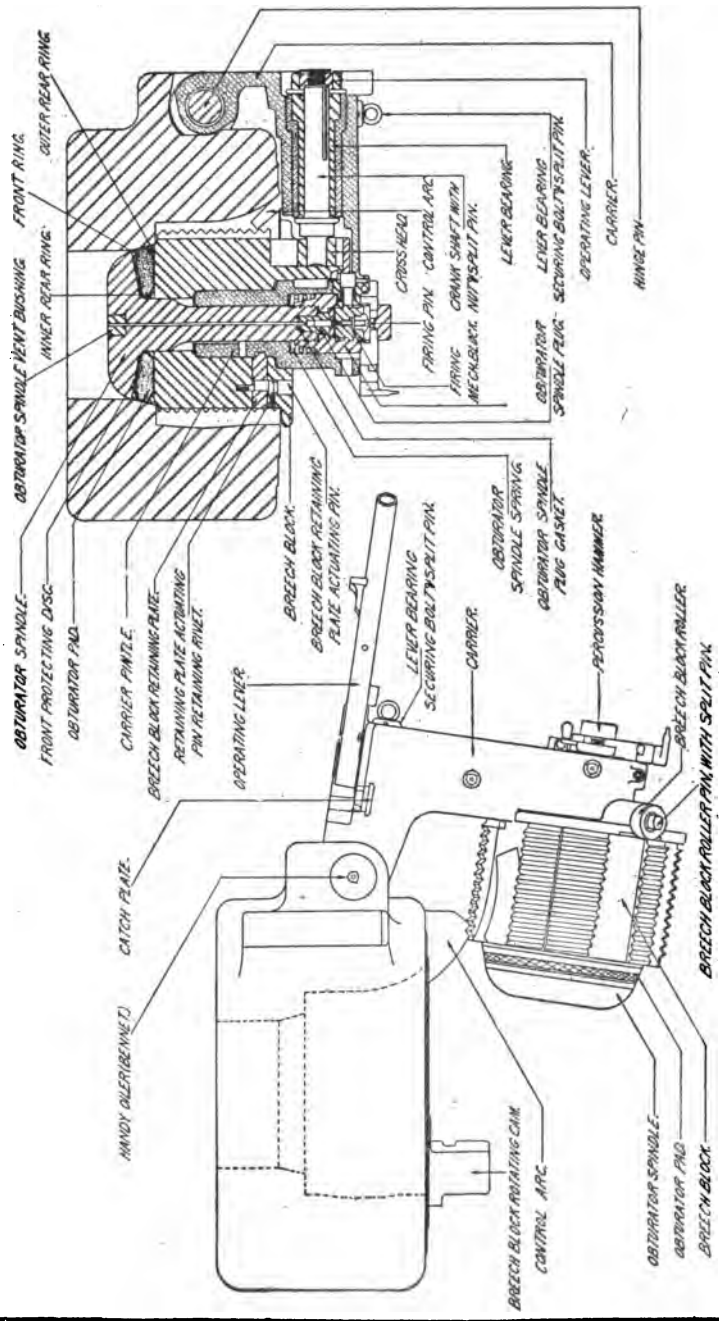

8 IN HOWITZER, MODEL OF 1917 (VICKERS MARK III)

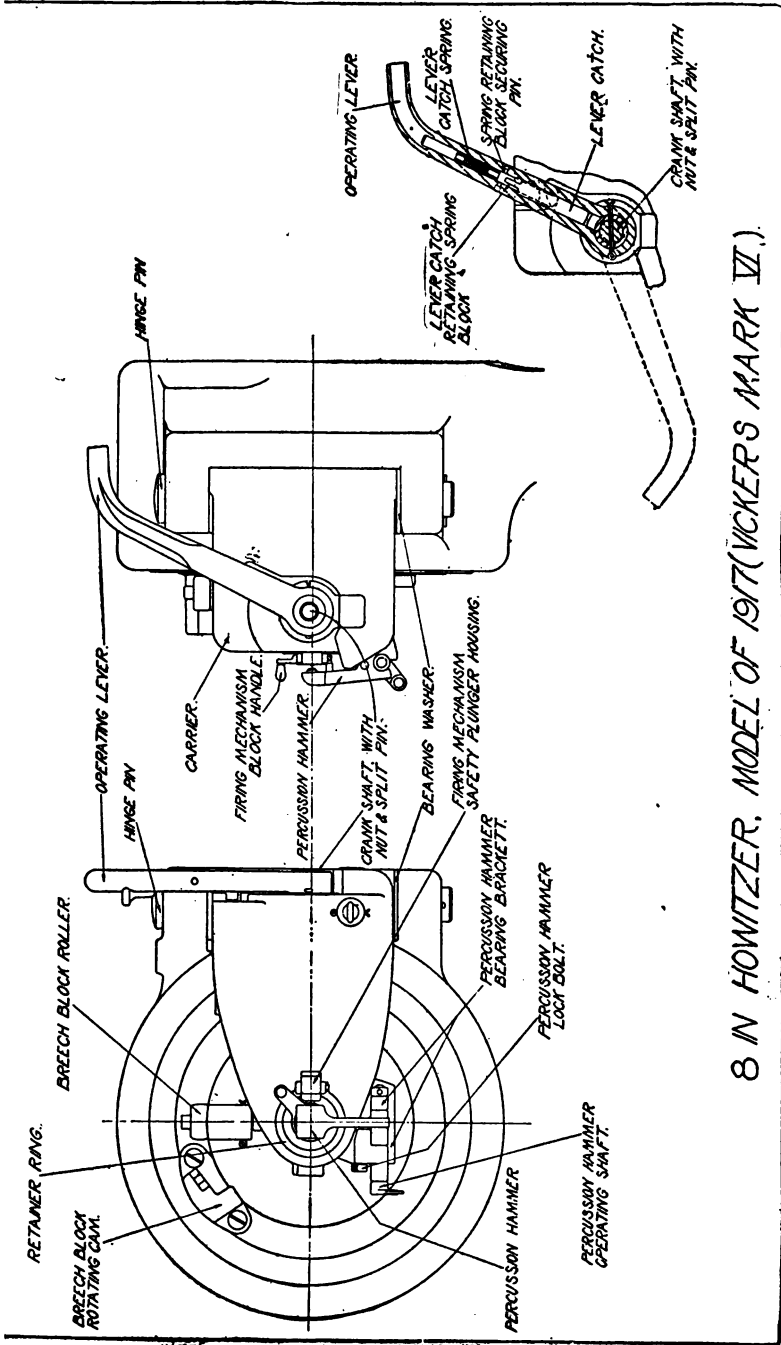

8 IN HOWITZER, MODEL OF 1917 (VICKERS MARK VI.)

The pad is inclosed between a front copper protecting disk, around the outer edge of which is a split steel ring, and a rear inner and outer steel ring, the outer one being split. The disk is stamped with the word "front" and the pad has the word "front" stenciled on the side which corresponds with the front disk, and "rear" on that which corresponds with the inner and outer rear rings, in order that they may be correctly assembled on the spindle.

If correctly assembled, the whole should fit together compactly.

Thin steel adjusting disks are provided for insertion behind the rear steel rings and pad when found necessary.

ACTION.

When the breechblock is swung into the breech recess, the obturator enters the chamber with ease; on turning the breechblock the pad is pressed home into the coned seat of the chamber by the travel of the block. The bore is thus closed by the pad which is in contact with the bore all around its circumference, while the mushroom head of the obturator receives the force of the gas on discharge. On firing the howitzer, the pressure acts on the mushroom head and compresses the pad against the breechblock, thus causing it to expand. This expansion is radial to the axis and equal in every direction, and is sufficient to prevent the escape of gas. On the pressure being removed elasticity comes into play and the obturator can be withdrawn from the coned seat as soon as the block is unlocked.

FIRING MECHANISM.

(Plate III.)

(a) ENGLISH "T" TUBE TYPE (FRICTION PRIMER).

A few howitzers have been designed for firing with "T" tube friction primers.

The obturator spindle on howitzers of this type extends through the outer face of the carrier. The spindle is secured by the obturator spindle nut. A spring which bears against the nut and a shoulder inside the pintle of the carrier keeps the gas check pad tightly pressed between the mushroom head and the breechblock.

The outer end of the vent in the obturator spindle receives the "T" tube primer and is prepared with a bayonet joint for the reception of the head of the same. A spring is provided round the outer end of the obturator spindle for retaining the primer in position. A safety shutter in the rear face of the breechblock prevents the insertion of a

primer in the vent until the breechblock is securely locked and the operating lever entirely home.

The "T" tube primer is turned into the firing position and withdrawn by hand.

The firing lanyard is pulled from the right side.

(b) FRENCH TYPE (PERCUSSION PRIMER).

The firing-mechanism housing is screwed onto the end of the obturator spindle and bears against the obturator spring. The firing-mechanism block is screwed into the housing. The firing-mechanism block is bored out to receive the firing-pin guide and the primer seat plug; the latter is screwed into the block and encircles the firing-pin guide. The primer seat plug has a slot cut in its forward end which receives the head of the primer. The firing pin is fitted in the firing-mechanism block and held in place by means of a housing screwed into the block. The firing-pin housing is held in place by the firing-pin housing holding screw. The firing-pin spring causes the firing pin to project sufficiently to be struck by the percussion hammer.

The firing-mechanism block is provided with a handle by means of which the block may be screwed into and out of the housing to renew the primer each time the gun is fired. The block is further provided with a flange in which is cut a recess to receive a lug on the front of the percussion hammer, and thus prevent the hammer from striking the firing pin except when the firing-mechanism block is screwed fully home.

Screwed to the face of the carrier to the right and above the firing-mechanism housing is the firing-mechanism block safety latch. This latch prevents the unscrewing of the block when the piece is fired.

The percussion-mechanism hammer is carried by an operating shaft which is journaled in a bearing bracket on the outer face of the carrier and offset at the end for attachment of the lanyard.

The firing-mechanism block is prevented from being inserted before the breechblock is fully closed by means of a spring-pressed safety plunger carried in the safety-plunger housing on the retaining ring. The plunger has a cam surface which, when the breechblock is not rotated to its fully closed position, bears against an arc cam surface on the breechblock and forces the pin out against the tension of its spring to project across the opening in the firing-mechanism housing and obstruct entrance of the firing-mechanism block.

Operation.—After the gun is fired and before opening the breech press back the firing-mechanism block safety latch, in order to free the han-

8-INCH HOWITZER
MODEL OF 1917—VICKERS, MARK VI
FIRING MECHANISM

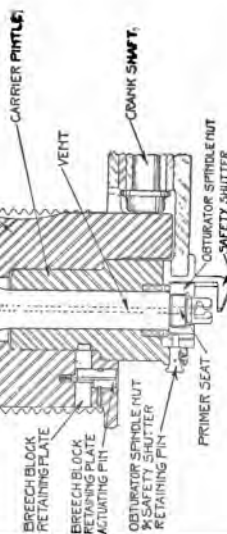
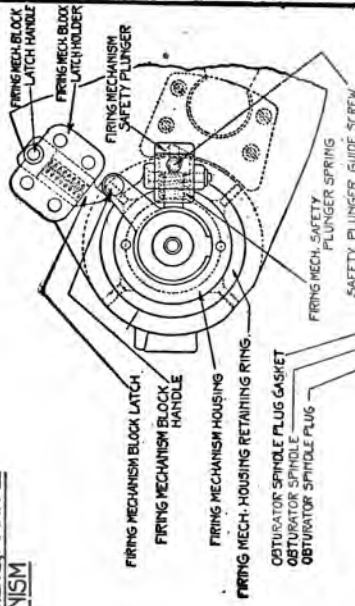
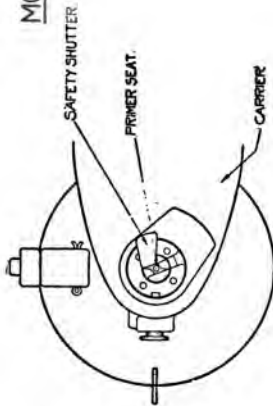

ENGLISH "T" TUBE TYPE

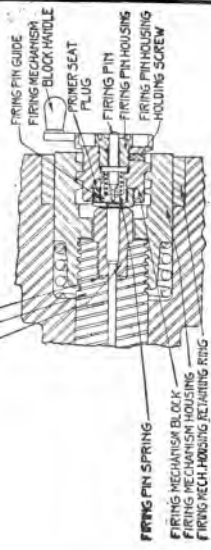

FRENCH TYPE



dle of the firing block. Unscrew the firing-mechanism block, slide the used primer out of the slot in the primer seat plug, insert a new primer, and after the breech is closed screw the block into the firing-mechanism housing. The firing-mechanism handle is automatically locked by the safety latch when the handle is rotated to its home position.

The firing-mechanism block is interchangeable with the firing-mechanism block used on the following guns:

- 155 mm. howitzer, model of 1918 (Schneider).
- 155 mm. howitzer, model of 1917 (Bethlehem).
- 155 mm. gun, model of 1918 (Filloux).
- 240 mm. howitzer, model of 1918 (Schneider).

TO REMOVE BREECH MECHANISM.

Before removing the mechanism, the breechblock must be opened and swung into the loading position.

OBTURATOR.

Unscrew firing mechanism block from the firing mechanism housing. Remove securing pin from the retaining ring and withdraw the safety plunger housing. Unscrew the firing mechanism housing and remove obturator spring. Withdraw obturator spindle, pad, and rings as a unit from the front end of the breechblock.

BREECHBLOCK.

Insert a screw driver in slot of securing pin of the retaining plate, press in the pin and partially revolve it by means of the screw driver until the indicating arrow on the pin corresponds with the middle of the word "dismantle" on the breechblock, then withdraw the breechblock from the front of the carrier.

ROLLER.

Remove the securing pin and roller axis pin, and withdraw the roller.

BREECH MECHANISM LEVER.

Remove the securing pin and nut from the crank shaft, and withdraw the breech mechanism lever.

BREECH OPERATING LEVER BEARING, CRANK SHAFT, AND CROSSHEAD.

Remove the securing pin and nut of the lever bearing securing screw, and withdraw the securing screw. Withdraw the bearing and crank shaft from the carrier; at the same time, from inside the carrier, remove the crosshead from the inner end of the crank shaft.

CATCH, BREECH-OPERATING LEVER.

Drive out the securing pin of the spring retaining block, slide the catch downward in the breech operating lever and withdraw the catch, then remove the spring and retaining block.

CARRIER.

Remove the securing pin from the carrier hinge pin, and withdraw the latter, then remove the carrier and bearing washer.

The undermentioned parts are not intended to be removed except on account of repair, as securing screws or stop rivets would have to be drilled or cut to effect their removal:

- Control arc.
- Breechblock rotating cam.
- Breech-operating lever catch plate.
- Breechblock retaining plate.
- Safety plunger housing retainer ring.

TO ASSEMBLE THE BREECH MECHANISM.

The converse of the above takes place in reassembling the breech mechanism.

CARE AND PRESERVATION OF HOWITZER AND BREECH MECHANISM.

The breech mechanism and also the projections on the exterior of the howitzer, which form guides for the latter when sliding in the cradle, should be kept clean, oiled or greased, and maintained in good working order; all working surfaces must be well lubricated, and the mechanism should be taken off frequently for this purpose.

The threads of the breechblock should be free from burrs; should the block not work easily when the obturator has been detached, the defect may often be remedied by careful filing, but no portion of the thread should be cut away to remove a crack.

The breech should be kept covered up when possible, to prevent dust and grit getting into the interstices of the breech mechanism and impeding their easy working. A cover is provided for this purpose.

List of lubricators in breech mechanism.

Parts to be lubricated.	Lubri- cator.	Position of lubricator.
Bearing of operating lever.....	1	On top side of carrier.
Carrier hinge joint.....	1	On top side of hinge pin.
Breechblock and pintle of carrier.	1	On top side of breechblock.

PLATE IV

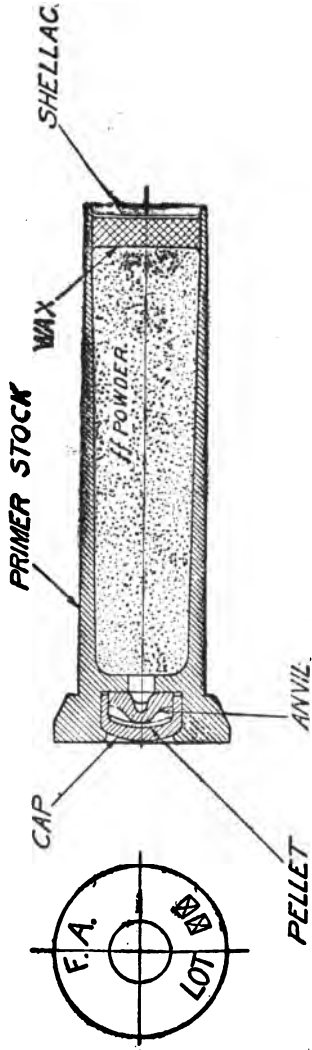

21 GRAIN PERCUSSION PRIMER MARK II

5633-207

CARE OF THE HOWITZER.

After firing, the bore of the howitzer should be cleaned to remove the residue of smokeless powder and then oiled. In cleaning, wash the bore with a solution made by dissolving $\frac{1}{2}$ pound of sal soda in 1 gallon of boiling water. After washing with the soda solution, wipe perfectly dry, and then oil the bore with a thin coating of light slushing oil furnished for this purpose. A brush is used to apply the oil.

The breech mechanism, firing and percussion mechanisms should be dismounted from time to time and cleaned and oiled. Kerosene is issued for cleaning purposes only and may be applied with a rag or wad of cotton waste. Engine oil No. 1 is provided for oiling, and in general for lubricating all bearings not provided with compression grease cups.

The spare parts should be well coated with vaseline or heavy oil and each piece then wrapped in paper to prevent the oil from being rubbed off.

In the event of the obturator channel becoming choked with residue, the tapered portion should be cleaned with the cleaning reamer provided for this purpose, sufficiently to allow the insertion of a primer, which, when fired, will remove the rest of the obstruction.

**AMMUNITION FOR 8-INCH HOWITZER, MODEL OF 1917
(VICKERS, MARK VI).**

Separate loading ammunition is used in the 8-inch howitzer, consisting of high explosive common steel shell only. Each round is issued with the projectile filled, but unfuzed, with the fuze hole closed with a suitable plug. The weight of the projectile complete is 200 pounds, and the total weight of a complete round, including propelling charge, is approximately 211 pounds. The components of each round are the cartridge, primer, projectile, bursting charge, and fuze.

PRIMER.

(Plate IV.)

The 8-inch howitzer is made to take a percussion primer known as the 21-grain percussion primer, Mark II. This primer has no exterior thread, and is held in its seat by the firing mechanism.

To insure the ignition of the propelling charge of smokeless powder in the cartridge, it is necessary that either the primers contain in themselves, in addition to the percussion composition, an auxiliary charge of black powder, or that an auxiliary charge of such powder be placed in the rear and core of the cartridge to communicate the flame from the percussion primer and thoroughly ignite the smokeless powder, or both.

The percussion primer known as the 21-grain percussion primer contains an igniting charge of 21 grains of black powder in addition to the essential elements of a percussion primer. The 21-grain percussion primer, Mark II, is shown assembled in Plate IV, and consists of a brass case resembling in shape a small-arms cartridge case. The head, or rear end, of the primer is countersunk, forming a cup-shaped recess, in which the percussion primer proper is fitted. The latter consists of a cap, anvil, and percussion composition, assembled as shown in Plate IV. The percussion composition contains the following ingredients:

	Per cent.
Fulminate of mercury.....	35
Chlorate of potash.....	35
Sulphide of antimony.....	30

The percussion cap recess is connected with the interior of the primer case by a small vent. The body of the case contains 21 grains of black powder, constituting the rear igniting charge for the igniting charge in the cartridge. This black powder is inserted under sufficient pressure to retain it in the primer, and a layer of composition wax is used to close the end. The outside surface of the wax is covered with a layer of shellac to insure water-tightness.

In action the blow of the firing pin of the breech mechanism explodes the percussion cap, which ignites the black powder. The flames of the latter shoot out and ignite the auxiliary charge of black powder in the cartridge, which in turn ignites the smokeless-powder charge.

THE CARTRIDGE.

(Plate V.)

The propelling charge of smokeless powder for the 8-inch howitzer, Mark VI, is a sectionalized charge consisting of four sections or bags of powder comprising a base charge and three small increments corresponding to firing zones and marked accordingly. The bags are made of raw silk and tied together as shown on Plate V. The total cartridge of four bags covers practically the full length and diameter of the powder chamber, and weighs about 10 pounds 12 ounces. A small igniting charge of about 3 ounces of black powder is inserted by increments at both ends and at the center of the base charge and at the center of the incremental charges to receive the flame from the primer.

The full charge is used for maximum range firing, and as firings in inner zones are desired, one or more of the sections of the charge are removed. In addition to the increments shown above the 8-inch howitzer, Mark VII, takes two additional increments giving two more zones of fire.

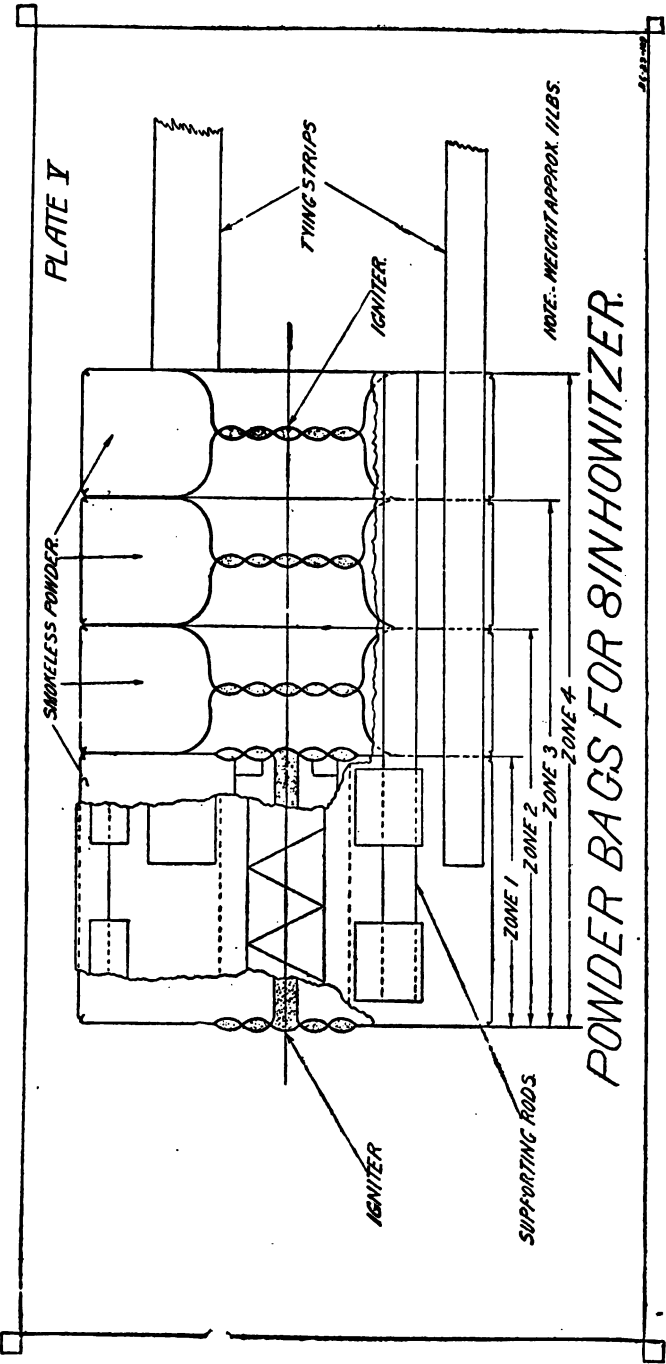

PLATE V

SMOKELESS POWDER.

TYING STRIPS

IGNITER

NOTE: WEIGHT APPROX. 11 LBS.

ZONE 1

ZONE 2

ZONE 3

ZONE 4

IGNITER

SUPPORTING RODS.

POWDER BAGS FOR 8 IN HOWITZER.

25-92-100

PLATE VI.

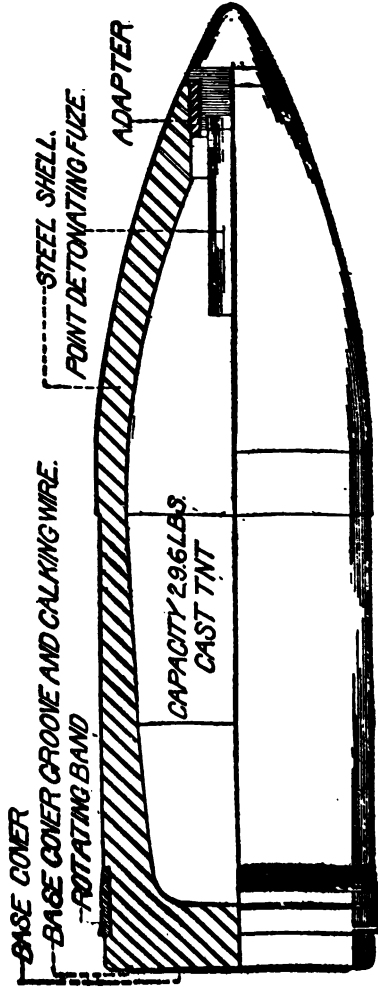

8 IN COMMON STEEL SHELL MARK-I.

THE PROPELLING CHARGE OF SMOKELESS POWDER.

The powder composing the propelling charge is a nitrocellulose powder consisting of multiperforated cylindrical grains. The weight of the charge varies slightly for different lots of powder, but is approximately 10 pounds 12 ounces. The weight is determined from the acceptance test of the lot, which also gives the standard muzzle velocity for that particular lot.

ADDITIONAL POWER INCREMENTS.

(Used in 8-inch howitzer, Vickers Mark VII.)

To obtain the two additional zones of fire made possible by the greater chamber capacity of the 8-inch howitzer, Vickers Mark VII, six separate charges of smokeless powder are provided as against four for the 8-inch howitzer, model of 1917, Vickers Mark VI. The base charge alone gives a muzzle velocity of 1,300 feet per second, reaching the inner zone. The maximum charge gives a muzzle velocity of 1,521 feet per second, giving the extreme range of the howitzer.

THE COMMON STEEL SHELL.

(Plate VI.)

The common steel shell for use with the 8-inch howitzer has a total length of 28.51 inches fuze, and an ogival head struck with a radius of four calibers and is fitted with a copper rotating band forced into an undercut seat 1 inch from the base of the shell. The bottom of the band seat in the shell is roughened to prevent slipping of the band. The base of the shell is solid and is fitted with a base cover consisting of a lead disk and copper cover, which are calked into a circular undercut groove in the shell base, with lead calking wire. This cover is to prevent leakage of flame from the propelling charge through the shell base, which might cause a premature explosion of the shell in the bore of the howitzer. An assembled view of the shell is shown on Plate VI.

The cavity of the shell is 24.26 inches long, 4.85 inches in diameter at its base, and 6.4 inches in diameter at about midway of the shell, and decreases in diameter toward the front in accordance with an arc radius of 3.2 calibers. Its capacity unfuzed is approximately 530 cubic inches, and fuze, approximately 519.82 cubic inches.

When finished, the cavity is lacquered to diminish the danger of premature ignition of the bursting charge from friction, and the exterior is painted the distinctive colors prescribed by the Ordnance Department. The loaded shell contains a bursting charge of about 29.6 pounds trinitrotoluol. The weight of the shell with bursting charge, fuze, and base cover is 200 pounds.

THE FUZE.

(Plate VII.)

The 8-inch howitzer common steel shell is fitted at its front by means of a suitable adapter with a fuze known as the point detonating fuze, Mark II. The head of the fuze is shaped so as to continue the ogival shape of the shell head to a point, as shown in Plate VI.

This fuze is of the centrifugal arming type and may be fitted for either delay or nondelay action. The principal parts are as follows:

Body.	Safety plunger spring.
Head.	Firing pin.
Plunger.	Firing-pin bushing.
Booster tube.	Firing-pin spring.
Booster charge container.	Detonator cap ring.
Base plug.	Primer (delay or nondelay).
Detonator plug.	Relay detonator.
Safety plunger (centrifugal).	Detonator spring.
Safety plunger bushing.	

The primer, relay detonator, and detonator proper are mounted on the plunger.

This fuze is also of the type which has what is known as the detonator safety feature. Before arming, the detonator is separated from the booster charge and is surrounded by an air chamber in such a manner that if the detonator should become ignited prematurely, either in storage or in the bore of the gun, the gases can expand into the safety chamber and not cause the booster charge to explode and ignite the bursting charge of the shell.

In action the detonator charge proper is located in the safety chamber, until on firing the propelling charge the centrifugal force due to the rotation of the projectile causes the safety plunger to move outward against its spring, releasing the plunger; the plunger then moves forward into the armed position and is locked there by the opening of the ring, which abuts against the shoulder on the interior of the fuze head. On impact, the firing pin is driven into the percussion primer, which ignites the relay detonating charge; the resulting flame ignites the detonator proper, exploding the booster charge, which ignites the bursting charge in the shell.

The centrifugal arming of this fuze is an added safety feature, it being relatively impossible to arm the fuze by ordinary handling. However, extreme care should be taken in disassembling this fuze when recovered in unexploded shell.

PLATE III

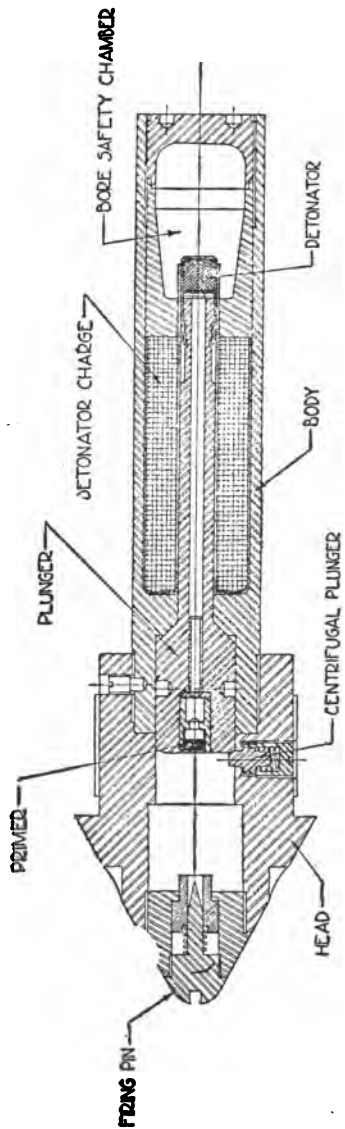

POINT DETONATING FUZE MARK II

91-22-27



1. The first part of the document discusses the importance of maintaining accurate records of all transactions and activities. It emphasizes the need for transparency and accountability in financial reporting.

2. The second part of the document outlines the various methods and techniques used to collect and analyze data. It covers both qualitative and quantitative research approaches, highlighting their strengths and limitations.

3. The third part of the document focuses on the interpretation and analysis of the collected data. It discusses how to identify trends, patterns, and correlations, and how to draw meaningful conclusions from the results.

4. The fourth part of the document addresses the challenges and limitations of data collection and analysis. It discusses issues such as data quality, bias, and the potential for misinterpretation, and offers strategies to mitigate these risks.

5. The fifth part of the document provides a summary of the key findings and conclusions. It highlights the main insights gained from the research and discusses their implications for practice and policy.

6. The final part of the document includes a list of references and a list of figures and tables. The references provide a comprehensive overview of the literature related to the research, while the figures and tables provide a visual representation of the data and results.



PLATE VIII

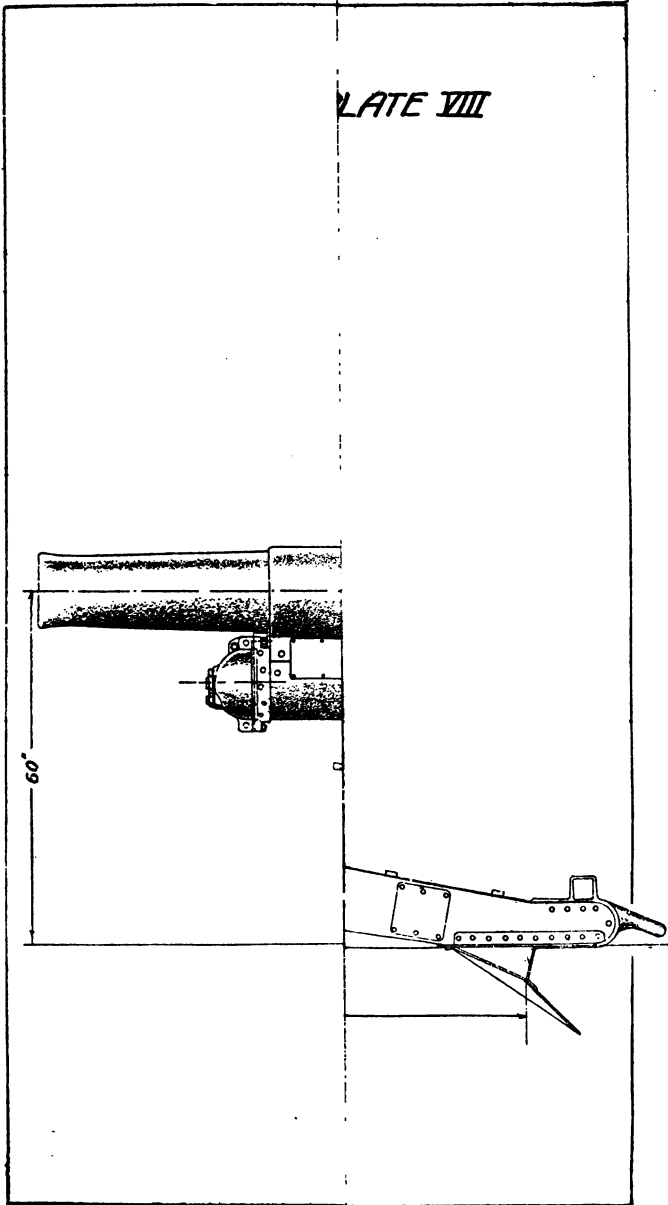

PACKING FOR SHIPMENT.

The components of the rounds for the 8-inch howitzer are prepared separately for shipment. The common steel shell is shipped unfuzed, with the fuze hole stopped with a suitable plug. A ring bolt is fitted to the plug to facilitate handling, and a fiber or rope ring is placed around the base of the shell to protect the copper rotating band. Punch marks on the outside of the shell indicate its size, weight, and loading.

The primers are placed in hermetically sealed tin boxes, 20 to a box, and 25 of these tin boxes are placed in a moisture-proof wooden box, which is so marked on the outside as to indicate its contents and the lot number of the same.

The point detonating fuzes are packed for shipment in a suitable wooden box, 50 in a box, which is so marked as to indicate its contents and the lot number of the same.

The charges of smokeless powder will be shipped in metal-lined air-tight containers, suitably marked on the outside to indicate the contents and lot number of the same. The number of charges for shipment will be determined by the proper authorities.

MISFIRES AND HANGFIRES.

Misfires and hangfires are of rare occurrence. In case of the failure of the gun to fire when the percussion hammer is pulled, the pull should be repeated without opening the breech. The breechblock should not be opened until after the expiration of at least one minute from the time that the percussion hammer is last pulled.

8-INCH HOWITZER CARRIAGE, MODEL OF 1917 (VICKERS MARK VI).**WEIGHTS, DIMENSIONS, ETC.**

Weight of carriage, with howitzer.....	pounds..	19, 100
Weight at end of trail.....	do....	588
Weight of limber complete, with tools, approximately..	do....	2, 600
Height of axis of howitzer.....	inches..	60
Height of sight line, panoramic sight.....	do....	69
Height of eyepiece, panoramic sight.....	do....	60.5
Width of carriage over axle.....	do....	95.8
Track, carriage, and limber wheels.....	do....	88
Turning angle.....	degrees..	40

PLATE IX

DE
ARK(VI)

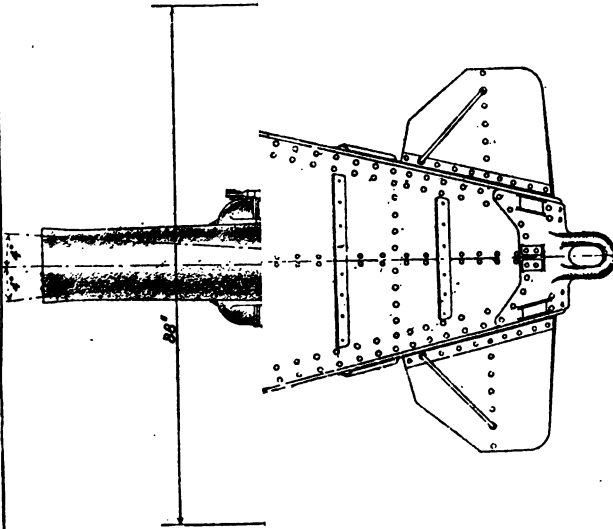

The rear end of the trail is fitted with the ordinary type of spade for firing on firm ground. This spade is bolted to the trail and may be removed and replaced by a float plate to which is attached a thrust bracket for use with the firing platform to be described later. For firing on stony ground or with scotches, this thrust bracket is covered by a recoil shoe which is bolted to the float plate.

The sighting gear is pivoted on a bracket attached to the cradle on the left side at the rear. The sight is kept in a vertical position by a parallel motion.

A traveling lock is provided to lock the cradle to the trail while traveling.

The principal parts of the carriage are:

Trail with spade.	Traveling lock.
Axle and wheel.	Hydraulic recoil cylinder with variable recoil gear.
Brake gear.	Hydropneumatic recuperator.
Top carriage.	Elevating gear.
Traversing gear and traversing indicator.	Sighting gear.
Cradle with quick-loading gear.	

TRAIL.

The trail consists of two steel flasks joined at their front ends by a transom and at the rear by a top and bottom plate. The top plate has three oak slats fixed across it to facilitate loading. The transom is pierced vertically to receive the pivot pin of the top carriage. Each flask carries a clip in which a lug on the rear end of the top carriage slides. The top front end of each flask is fitted with a facing strip on which the saddle rests and clips are also attached at this point to engage with lugs on the top carriage to prevent the latter lifting on firing. A bracket is riveted to either flask, underneath, in which bearings are formed for the axle. Each flask also carries brackets for the attachment of the traveling lock. Near the lower end of the top plate, clips are riveted for attaching the portable air compressor while charging the recuperator. The lower end of the trail is fitted with locking plates, spade, trail eye, lifting handle, and sockets for the hand spike. There are fittings on the trail for housing a combined rammer and sponge, hand spikes and loading tray, and leather cases to carry the sight clinometer and two reamers, also a block housing the oil can.

A draft link is riveted to the center of the front transom; the front end of the link is forked and is provided with a pin and key for connecting to the firing platform.

TRAIL AND WHEELS.

TRAIL—The trail of the sled is a cylinder of wood and fits in bearings on the supports of the trail. At each end of the cylinder a washer through which is a bolt in the trail. The washers have tapered extensions which fit the axle nuts. The trail and the axle nut is prepared to take a nut and pin to hold the wheel in position.

WHEELS—Trailing wheels are supplied with this equipment. They are of steel, 16 inches in diameter with a tread 12 inches in width. Diagonal ribs are turned across the tread to give a better grip on soft ground. A steel brake ring is secured to the inner circumference of each wheel.

The wheels are held in the axle nuts by a nut washer, nut, and a pin which passes through the nut and axle nut, is held underneath by a spring pin.

The wheels are not interchangeable from one sled to the other.

BRAKE BEAR.

TYPE II.

Screw brakes for use in firing and traveling are fitted, one to each side of the carriage, each acting independently.

Bolled to the axle bracket is a supporting bracket, the upper end of which carries a rotating pin, while its lower end has pivoted to it a steel arm forming a brake hanger. The upper end of the hanger carries a steel nut through which works a screw which also passes through the center of the rotating pin, in which it is held by a shoulder in front and disk springs with nut and pin in rear. A hand wheel is attached to the front end of the screw. The lower end of the hanger has attached to it a brake shoe, in which is secured a wood block to act against the brake ring on the wheel. Consequently when the screw is turned, the nut with the upper end of the hanger, travels along the screw, revolving the lower end of the hanger in an opposite direction and thus brings the block to bear against the wheel or revives it clear as the case may be, the rotating pin, revolving in its bearing, allows the screw and nut the necessary movement to conform to the arc of a circle described by the hanger.

TOP CARRIAGE.

The top carriage consists of two steel side pieces joined at their front ends by a transverse bar.

The transverse bar has a hexagonal opening in its center, formed to receive a nut and pin which also passes through the opening in the trail and is held underneath by a nut and pin.



At
on the
which
which
take
W
are o
Ding
grou
oach
T
pin.
by:
T

S
sic

w
st
a
c
r
f
t



the hydraulic recoil cylinder and recuperator. The front end is closed by a cap to which are attached the piston rods of the recoil cylinder and of the recuperator. The cap is fitted with a shutter which enables the pressure to be tested without disconnecting gears or removing the cap. Brackets are fitted to the cradle in which are formed bearings for the quick loading and the variable recoil gears. Leather pads inclosed by a brass casing are fitted to the front of the cradle to act as a stop to the howitzer in returning to battery. The cradle projects some distance beyond the breech of the howitzer to form a support for the latter in the recoil position. This projection is prepared on the underside to receive the traveling lock and on top to receive the loading tray.

A spring pointer attached to the front guide ring of the howitzer on the left side indicates the correct amount of recoil according to the elevation at which the howitzer is fired.

QUICK-LOADING GEAR.

(Plate XII.)

This gear is provided to unlock the cradle from the elevating arc, and thus allow the howitzer to be brought rapidly to the loading angle ($7^{\circ} 30'$ elevation) after firing, and vice versa.

The gear consists of a cross spindle supported in bearings of the underside of the cradle, to the right end of which is pinned the front end of the actuating lever, which is supported in a bracket on the right side of the cradle. The actuating lever has a cranked extension at its front end, to which is pinned the rear end of a connecting rod. The latter has pinned to it at its front end a spring plunger, which, when the howitzer is in loading position, engages in a recess in a bracket on the top carriage and so holds the cradle and howitzer ready for loading. A spring buffer is fitted above this plunger to cushion the shock on the gear when coming into loading position. To the left end of the cross spindle is attached a short lever, to the upper end of which is pinned a spring plunger, which, when the howitzer is in firing position, engages in a recess in the elevating arc and so locks the cradle to the arc. There is also attached to the elevating arc an emergency clamp and stop, which, when in place, will not permit the use of quick-loading gear.

Action.—The howitzer, having been fired, the actuating lever is raised. This revolves the cross spindle and lever, withdrawing the plunger from the elevating arc, compressing the spring, and unlocking the cradle. The actuating lever then comes to the end of its slot, and continuing to lift on it depresses the howitzer to the loading position, at which point the forward plunger is forced into its recess in the bracket on the top carriage of the action of its spring.

11
12
13
14
15
16
17
18
19
20
21
22
23
24
25
26
27
28
29
30
31
32
33
34
35
36
37
38
39
40
41
42
43
44
45
46
47
48
49
50
51
52
53
54
55
56
57
58
59
60
61
62
63
64
65
66
67
68
69
70
71
72
73
74
75
76
77
78
79
80
81
82
83
84
85
86
87
88
89
90
91
92
93
94
95
96
97
98
99
100

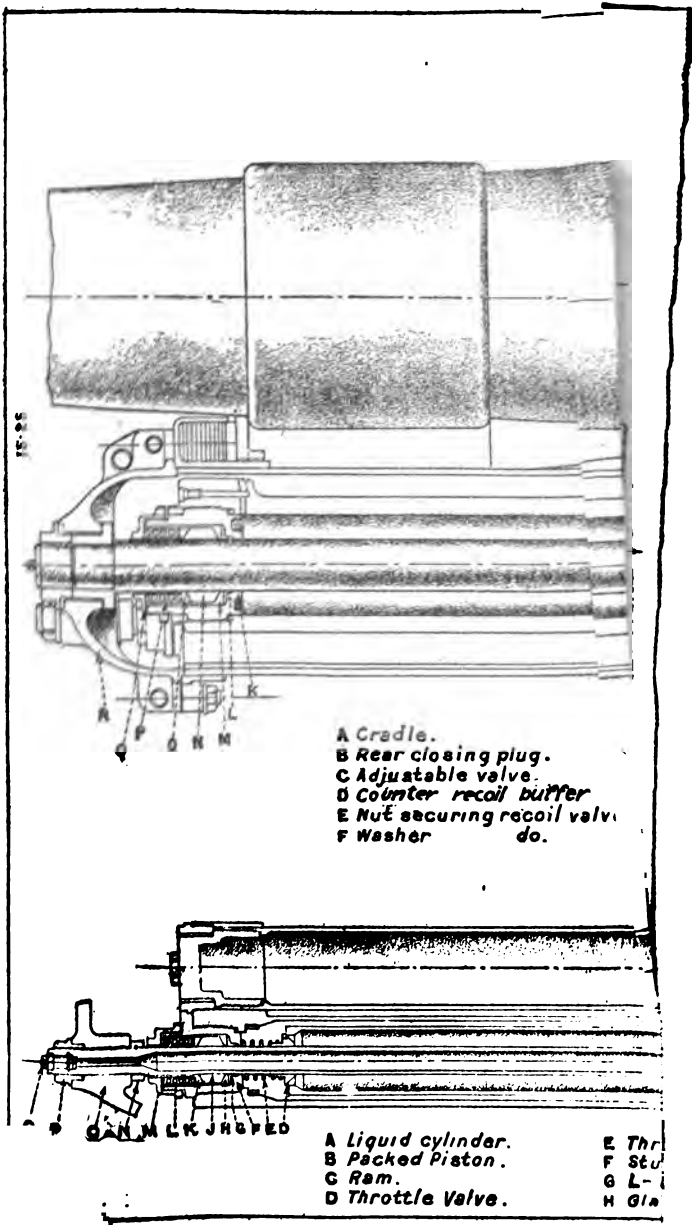

15205

- A Cradle.
- B Rear closing plug.
- C Adjustable valve.
- D Counter recoil buffer
- E Nut securing recoil valve.
- F Washer do.

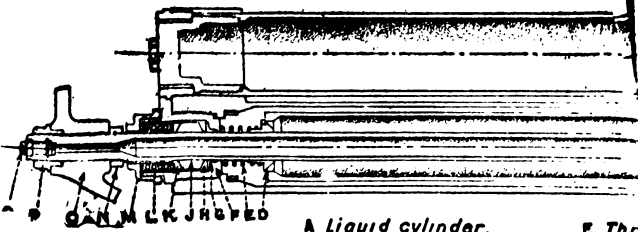

- A Liquid cylinder.
- B Packed Piston.
- C Ram.
- D Throttle Valve.
- E Thr
- F Stu
- G L-
- H Gl

After loading, the actuating lever is pressed downward, which withdraws the forward plunger, elevates the cradle and howitzer until the rear plunger, which slides along the elevating arc, comes opposite its recess in the latter into which it engages under the action of its spring, thereby locking the arc and cradle together.

TRAVELING LOCK.

(Plate VIII.)

A steel channel-shaped bar has one end pivoted to the top of the right clamp of the trail. On top of the bar are two double lugs, through which it is pinned to the cradle for traveling purposes. The other end of the bar is shaped to fit into a bracket on the left flask, to which it is secured by a pin, which, when not in use, is suspended on the right side of the bar by a socket and hook.

The traversing gear must be placed at zero before connecting the bar to the cradle. When not in use the bar is housed in a bracket on the top of the right flask of the trail.

The bar is made removable in order to give clearance to the handle of the loading tray when loading.

HYDRAULIC RECOIL CYLINDER.

(Plate XIII.)

The recoil cylinder and the recuperator cylinders are contained in a steel block forming a recuperator body which fits inside the cradle and is provided with a guide on each side to fit in the guideways on the cradle. The body is connected at its rear end to the lug of the howitzer, and thus recoils with it while the piston rod of the recoil cylinder and the rods of the recuperator are attached to the cradle cap. Five parallel openings are bored through the body, a center one to receive the recoil cylinder, two outside lower ones for the recuperator liquid cylinders, and two upper ones for the air cylinders.

The recoil cylinder has cut in its interior surface two spiral grooves to rotate the recoil valve during recoil. The front end is closed by a steel stuffing box, which is screwed into it against steel and leather washers to make a tight joint. The stuffing box contains an L leather, which is held in position by a hollow gland in which is placed the hemp packing ring. In front of this is placed a sleeve, against the flange of which bears a helical spring, the whole being kept in position by a cap which screws onto the stuffing box and bears against the spring. The stuffing box and cap are kept from unscrewing by locking plates.

The rear end is closed by a steel plug forming a counter-recoil buffer which is screwed in against a leather washer to make a tight joint and

is locked. The plug is threaded externally to receive a nut, by means of which the recoil system is connected to the lug of the howitzer and is bored out internally to form a counter-recoil buffer. A small passage is bored through it, which places the buffer chamber into communication with the recoil cylinder. This passage is closed by the stem of an adjustable valve on which is formed flats, by means of which the velocity of counter-recoil is regulated. The piston rod and piston are of steel in one forging with the counter-recoil buffer. The rod passes out through the packing at the front end and is fastened with a nut to the front cap of the trail. Behind the securing nut inside the cap the rod has keyed to it a steel collar, on which is formed a bevel gear, which forms a part of the variable recoil mechanism. The piston has two plain ports for the passage of liquid from one side to the other on recoil and counter-recoil, and a manganese-bronze ring around it to prevent scoring of the cylinder. The rod is hollow and front end is threaded to take an adapter, to which the pipe from the charging pump is connected when filling. A small hole at the rear connects the interior of the rod with the recoil cylinder. When the adapter is not in use the opening at the front is closed by a plug. The counter-recoil buffer projects from the rear of the piston and has a flat cut on it for the greater part of its length. The remaining portion is cylindrical and is a close fit inside the buffer chamber. The base of the buffer is prepared for the reception of the recoil valve and its fittings.

The recoil valve is of metal and fits loosely over the base of the counter-recoil buffer, around which it is free to revolve. It has two ports for the passage of liquid and has two studs or keys to work in the spiral grooves of the recoil cylinder. The valve is held up against the rear face of the piston by a steel washer. The washer is keyed to the counter-recoil buffer, and in turn is held by a threaded collar and pin.

The front end of the recoil cylinder is provided with filling holes, which are closed by plugs and leather washers.

VARIABLE RECOIL MECHANISM.

(Plate XIV.)

This mechanism consists of a steel actuating rod, held in bearings on the right side of the cradle; its rear end is forked and pinned to a block which fits around the right trunnion and is supported at its rear end on the trunnion cap pin, while its front end is attached to a short spindle which is formed on the outer end of a short spindle. The spindle is keyed to the cradle cap and carries on its inner end a bevel gear which meshes with a bevel gear keyed to the piston rod. Thus,

1911
1912
1913
1914
1915
1916
1917
1918
1919
1920
1921
1922
1923
1924
1925
1926
1927
1928
1929
1930
1931
1932
1933
1934
1935
1936
1937
1938
1939
1940
1941
1942
1943
1944
1945
1946
1947
1948
1949
1950
1951
1952
1953
1954
1955
1956
1957
1958
1959
1960
1961
1962
1963
1964
1965
1966
1967
1968
1969
1970
1971
1972
1973
1974
1975
1976
1977
1978
1979
1980
1981
1982
1983
1984
1985
1986
1987
1988
1989
1990
1991
1992
1993
1994
1995
1996
1997
1998
1999
2000
2001
2002
2003
2004
2005
2006
2007
2008
2009
2010
2011
2012
2013
2014
2015
2016
2017
2018
2019
2020
2021
2022
2023
2024
2025



when elevating the howitzer, the actuating rod pulls upon the short lever, rotating the cross spindle, bevel segments, piston rod, and piston, thereby decreasing the orifice between the ports in the piston and the recoil valve, which is held fast by its keys and grooves in the cylinder. This increases the resistance set up in the recoil cylinder during recoil, thereby shortening the recoil of the howitzer. The recoil varies from 60 inches, howitzer horizontal, to 24 inches at 50° elevation, or 0.72 inch per degree of elevation.

RECUPERATOR.

(Plate XIII.)

The recuperator is of the hydropneumatic principle and consists of two liquid cylinders in which work rams, and two air cylinders which contain both liquid and compressed air. The air cylinders are connected at their rear ends by an equalizing passage, and are also connected to the front end of the liquid cylinders by an annular recess around the latter, along which the liquid passes on recoil and counter-recoil.

The liquid cylinders are closed at the rear end by perforated caps which are held by pins. The perforations allow any liquid which may get by the piston to get clear, otherwise the howitzer would not return fully to firing position after recoil. They also prevent a vacuum forming in the rear of the recuperator ram.

The front ends are closed by stuffing boxes, packing and caps in much the same manner as the recoil cylinder. Internally near its front end, each cylinder is reduced in diameter to form a seat for a throttle valve, which fits loosely around the piston rod and is kept to its seat by a helical spring, one end of which bears against the valve and the other end against the inner face of the stuffing box.

The valves are provided with a coned head to fit tightly on their seat. Holes are bored through the head to allow liquid to pass back into the cylinders after recoil.

The recuperator piston rods are of steel; their front ends are secured by a screwed sleeve inside and a nut outside to the cradle cap, while their inner ends are provided with a packed piston. The packing consists of two U-shaped leathers properly held by supporting rings and secured by a nut, also a ring of hemp packing, which is kept tightly against the piston proper by a helical spring held by a nut.

The piston rods are hollow; and the front end of each is prepared to take an adapter to which the pipe from the charging cup is connected when filling. A small side hole at the rear connects the interior of the rod with the liquid cylinders. When the adapter is not in use, the opening at the front is closed by a plug.

The air cylinders are plain tubes, having their ends closed by steel plugs. At their rear end they are connected by a passage bored through the body of the recuperator, and they are also connected to the front of the liquid cylinders from a point in front of the throttle valves, by the annular passage which surrounds the liquid cylinders.

The front closing plugs are fitted with air holes at such a level as to insure the correct charging of the recuperator with liquid; the front plug of the left cylinder is fitted with a cut-off valve and is also prepared to take an adapter, to which the copper pipe leading from the portable air compressor is connected when charging, or to which the pressure gauge is connected for testing the air pressure in the system. When the adapter is not in use the opening is closed by a plug.

Action of recoil cylinder and recuperator.—For use the recoil cylinder is filled with oil. After filling, about one-tenth of a pint (English measure) is drawn off. Quantity required about 45 English pints (54 U. S. pints). The recuperator is filled with a mixture composed of 50 parts of glycerin, 50 parts of water, and 4 ounces of caustic soda per U. S. gallon (5 ounces per English gallon), up to the level of the air hole in left air cylinder (quantity required, 58.5 English pints, 70 U. S. pints), with howitzer laid horizontal and wheels level, and then charged with air to a pressure of 685 pounds per square inch.

Before firing, the operation of elevating prepares the buffer for the correct length of recoil.

On firing, the howitzer recoils along the cradle, taking with it the recoil and recuperator cylinder, the piston rod of the former and the latter remaining stationary. As the recoil cylinder is drawn back, the liquid passes through the ports in the recoil valve and piston from front to rear. At the commencement of recoil, the ports in the piston are uncovered by the recoil valve, but as recoil proceeds the recoil valve is caused to revolve on the piston rod by the grooves in the cylinder, thus causing the ports to be gradually closed, which increases the pressure and absorbs the energy of recoil of the howitzer.

The pistons of the recuperator force the liquid from the liquid cylinders into the air cylinders, the throttle valves being forced off their seats for this purpose, and the liquid entering into the air cylinders raises the air pressure in the system. Recoil having ceased, the valves close, the air expands and forces the liquid back through the holes in the valves into the liquid cylinders, thus returning the howitzer into firing position. The howitzer is prevented from returning into battery by the slowness with which the liquid is forced through the holes in the valves, and also by the counter-recoil buffer,

which, as the howitzer nears firing position, enters its chamber and displaces the liquid therein, first over the tapering flat of the plunger, and past the adjustable valve through the side channel and finally through the latter only.

ELEVATING GEAR.

(Plate XI.)

The elevating gear is supported in a bracket attached to the top carriage on the left side. Supported in bearings in this bracket is a longitudinal spindle which has at its rear end a handwheel and at its front end a bevel pinion. The pinion gears into a bevel gear on the lower end of an oblique shaft, on the upper end of which is a worm which gears into a worm wheel formed on the outer end of a short cross spindle, on the inner end of which is a spur pinion which engages with the elevating arc. The latter fits loosely around the cradle trunnion on the left side and has a recess to take the firing plunger of the quick-loading gear. When this plunger is engaged in its recess, the cradle and the arc are locked together and elevation or depression can be given only by working the elevating gear. The elevating arc carries on its upper side a link for attachment of one end of the connecting rod of the sight-operating gear.

The worm shaft is fitted with friction washers at either end of the worm and an adjusting brush with a locking plate at its lower end. The wheels and pinions are inclosed by a metal cover secured to the bracket with screws. A scale plate graduated up to 50° is attached to the bracket supporting the sight, the graduations being indicated by a pointer attached to a bracket on the top carriage. One revolution of the handwheel equals 45-foot elevation or depression, as the case may be.

CARE AND PRESERVATION OF THE CARRIAGE.

RECOIL CYLINDER.

Before firing, it should be ascertained that the recoil cylinder is full, that there is no leakage at the stuffing box, that the recoil cylinder is firmly attached to the lug on the howitzer, and the piston rod to the cradle cap.

To fill the recoil cylinder.—Elevate the howitzer to 5° (having first lashed it to the cradle to prevent it slipping back), remove the nuts of the piston rods of the recoil cylinder and the recuperator, disconnect the variable recoil gear, and remove the cradle cap.

Remove the filling plugs of the recoil cylinder and the plug at the front end of the piston rod. Screw the adapter into the piston rod,

When the ... windows at the filling ... position and ... about ...

Disconnect ... screw ...

Disconnect ... packing ... connect ...

Disconnect piston ... stuffing ... insert new ...

... fitted to ... result as much ... the piston rods ... the packing ... together with ... may run ... in the stuffing ... Retill ... cap, and ...

... the nuts ... remove the ...

Warning.—The greatest care must be taken to see that the recuperator is correctly filled, as too much liquid may cause serious damage and put the howitzer out of action. When properly filled, the recuperator should contain about 58.5 English pints (70 U. S. pints).

On no account must liquid be added to the recuperator after filling; should sufficient liquid have been lost to reduce the pressure below 550 pounds per square inch, the recuperator must be emptied and refilled.

The cradle must be set absolutely horizontal, both lengthwise and crosswise, to a clinometer, to insure correct filling. (See figs. 1 and 2.) This is very important, for if the cradle is elevated only $\frac{1}{2}^{\circ}$, 6 pints too much liquid can be put in before it will overflow at holes D and E, and 1° elevation will allow $12\frac{1}{2}$ pints too much liquid to be put into the recuperator before overflowing at the above holes; therefore, too much care can not be taken to keep the recuperator perfectly level while filling. (See figs. 1 and 2.)

Take care to see that plugs are removed from both holes D and E. (See fig. 5.)

If either plug is left in when filling and the cradle is not level crosswise, too much liquid may be put in and cause serious damage to recuperator.

If it should be necessary at any time to remove from left reservoir the front end plug which contains the hole and plug E, care must be taken to see that when the plug is replaced and the joint made tight both holes are practically on the vertical center line in the bottom position as shown in figure 5.

The plug in hole D in the right-hand air cylinder is of larger diameter than plug in hole E in the left-hand air cylinder. However, the bottom of the hole D is level with the bottom of the hole E.

Lash the howitzer to the cradle before removing the front cradle cap, so as to prevent the howitzer from slipping back, or put a bar through the holes in the rear of the cradle and hold the howitzer in position by a wooden block placed between the howitzer and the bar.

If the cradle cap is to be left off for a long time, the elevating hand-wheel should be taken off.

In charging the recuperator with compressed air, it is important to see that the collars are screwed onto both recuperator piston rods before any pressure is put in the recuperator. The collars bear against the piston rod glands and prevent the rods from being forced out to the rear of the cylinders when under pressure and disconnected from the cradle cap. The recuperator should be filled under the instruction of a commissioned officer only.

Liquid for recuperator.—The liquid for the recuperator is a mixture composed of 50 parts of glycerin, 50 parts of pure water, and 4 ounces of caustic soda (NaOH) per United States gallon (5 ounces per English gallon). The glycerin used in this mixture must be neutral. Blue litmus paper should not turn red on being immersed in the mixture. If it shows red, titrate with caustic soda and stir until the acid is neutralized, which will be when blue litmus paper shows no red on being immersed. The glycerin provided should test 25° Baumé. If it is necessary to use a heavier glycerin, the amount of pure water should be increased.

It is essential to keep the liquid clean and free from grit when filling. Sand or grit in the liquid will cause damage to recuperator.

Figure 1 is a cross section of the recuperator, showing the correct level of the liquid, and figure 2 is a longitudinal section, also showing

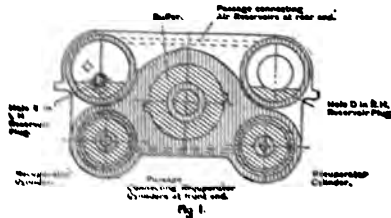

the correct level of the liquid, if filled while the recuperator is perfectly level and both plugs D and E removed.

Figures 3 and 4 show how the recuperator can be overfilled and the air space consequently reduced if the recuperator is not level in either direction while it is being filled, and if plugs are not removed from both holes D and E.

Figure 5 is an end view showing the lettering of the holes and plugs for reference to these instructions, and it will be noted that on the actual recuperator all the plugs are stamped with the same letter as the hole to which they belong and are in accordance with this drawing.

Operation.—First let pressure out of the recuperator as follows: Elevate horn to about 3°. Remove plug F and open valve G until there is no pressure in the recuperator. Close valve G and replace plug F.

Attach oil pump connection and adapter at H. Set the cradle level both longitudinally and vertically to a clinometer. It is very important that this leveling be done very carefully. The wheels of the carriage

should be blocked up if necessary.

Remove plugs D and E and pump in liquid until it overflows at D and E. Replace plugs D and E, elevate the howitzer about 5°, and remove adapter and replace plug H. Bring howitzer level.

Remove plugs D and E and add liquid until it overflows at D and E. The liquid should overflow at D and E simultaneously since the bottom of the hole for each plug is on the same level. Replace plugs D and E.

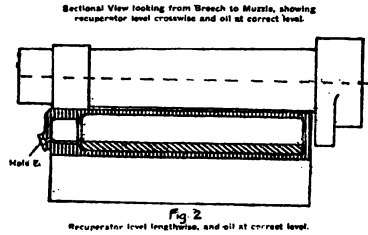

The quantity of liquid required is about 58.5 English pints (70 U. S. pints). The composition of the liquid is equal parts of glycerin and pure water with 5 ounces of caustic soda per English gallon (4 ounces per U. S. gallon).

NOTE.—If the liquid is pumped into the recuperator very rapidly, it may begin to overflow at D before it has had time to fill up in the other air cylinder to the level of hole E, owing to the viscosity of the liquid. Stop pumping for a few moments to allow the liquid to settle to its proper level in both cylinders, then resume pumping.

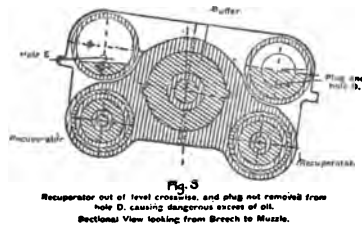

To charge recuperator with compressed air.—See that the threaded collars are in position on recuperator piston rods. Care should be taken during pumping that these collars bear only on the gland nuts and not on gland sleeves of rods.

Attach the air compressor to the clips on the trail, and connect the copper piping to the delivery of the compressor.

Remove plug F and attach the adapter with the pressure gauge.

Remove the cap from the adapter and connect the compressor pipe to the adapter and see that all joints in the pipe are properly tightened.

Open valve G and pump until pressure gauge registers 185 pounds per square inch.

Close valve G and disconnect compressor pipe from adapter and replace cap in adapter.

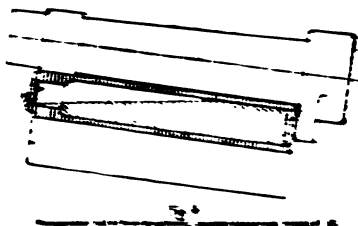

Reduce the pressure slowly to 180 pounds per square inch by slacking back the cap on the adapter a little and opening valve C slightly.

To make up the pressure after leakage. — Proceed exactly as for charging the recuperator with air, but, before opening valve G to admit air into the recuperator, pump the pressure in the pipe up to 185 pounds per square inch.

If on examination it is found that the pressure is between 550 and 685 pounds per square inch, it is not considered necessary that the liquid

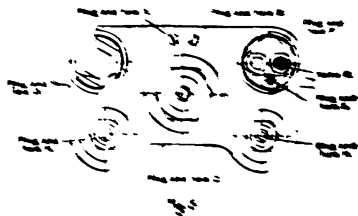

should be interfered with, but simply pump in additional air to make the pressure up to 685 pounds per square inch, and only when the pressure is below 500 pounds per square inch should the recuperator be purged of both air and liquid and recharged.

To empty recuperator. Set cradle about horizontal.

Remove plug B and open valve G to blow off air pressure.

Remove both recuperator stuffing boxes and run oil off.

Remove plug H to insure draining recuperator piston rod

Rock the cradle up and down on the trunnions from a few degrees elevation to a few degrees depression, to insure draining the air cylinders.

When sure there is no more oil left in the air cylinder, depress the front end of the cradle as much as possible to run all the oil out of the recuperator passages. To do this, lift the trail eye as much as necessary.

GENERAL INSTRUCTIONS FOR CARE OF RECUPERATOR.

When putting the L leathers in the stuffing boxes of the recoil cylinder and recuperator, see that the flat surface is well-bedded down to the metal. If this is not done the joint may leak and cause damage to the stuffing box.

See that all leathers and all working parts and parts of the stuffing boxes are clean and free from grit before replacing them in the cylinder. The leathers should be well steeped in oil if possible before putting in, or well oiled by hand.

Replacement of piston-rod packing.—If, during the return to battery of the howitzer, it is noticed that liquid is forced out through the holes in the closing cap at the rear end of the recuperator cylinders, it denotes faulty packing on the pistons of the recuperator and it should be remedied as follows:

The air must be exhausted, the recuperator emptied of its liquid as previously described, and the securing nut of the recoil cylinders and recuperator body unscrewed and removed. The operation of replacing the old packing is as below:

Assembling the leather U rings, recuperator piston.—When it is desired to replace the packing or the leather rings of the recuperator piston, the piston and piston rod should be removed from the cylinder, having first removed the stuffing box at the front end of the cylinder.

(a) *To replace leather U rings.*—Unscrew securing nut and remove supporting rings and leathers. Replace with new leathers, which have previously been soaked in the recuperator liquid. Replace securing nut and pin.

(b) *To replace packing.*—Remove nut on the rear end of piston rod, take out spring and packing supporting ring. Put in new packing and replace the supporting ring, spring, and nut. Replace pin.

Care should be taken when entering the piston into the cylinder that the edges of the leather U ring are not injured. No great force should be required to replace the piston in the cylinder. It should be just tight enough to require its being tapped lightly with a mallet.

Assembling the packings for recuperator and recoil cylinder stuffing boxes.—The L packing hydraulic leather rings for the stuffing boxes

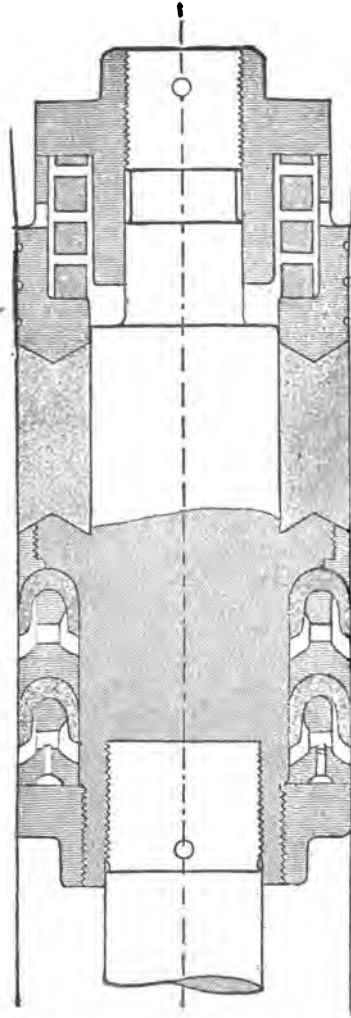

Figure 6.

— ASSEMBLY OF PISTON —
RECIPERATOR

should be oiled all over immediately before assembling. The leather rings should pass over their respective piston rods with a moderate push. They should not be so loose that they will slip easily, nor should they be so tight as to require driving along the rod.

To tighten the packing caps or to replace the recuperator packing.—When it is desired to replace the recuperator packing, the air must first be allowed to escape before removing the threaded collar from the piston rod.

PLUGS, ETC., OF RECOIL CYLINDER AND RECUPERATOR.

The plugs are all provided with locking plates, and care should always be taken after any of them have been removed for any purpose to replace the locking plates.

CRADLE.

The guideways on the cradle, in which the howitzer and recoil mechanism slide, should be kept clean, free from burrs, and well lubricated.

ELEVATING GEAR.

The elevating gear should be kept clean, well lubricated, and the teeth of the pinion and wheels greased. If there is any lost motion in the gear it should be taken up by changing the adjusting bush at the lower end of the worm shaft, having first removed the cover.

TRAVERSING GEAR.

To be kept clean and well lubricated.

BRAKE GEAR.

Must be kept clean and well lubricated. Worn blocks must be replaced by new ones which are carried in the spare parts.

TRAVELING LOCK.

The traveling lock must always be used when traveling to prevent any strains coming upon the elevating and traversing gears. Before connecting it to the cradle, it should be seen that the traversing indicator is at zero, and that the plungers of the quick-loading gear are withdrawn from their recesses in the elevating arc and top carriage.

List of lubricating holes on carriage.

Fittings which are provided with oil holes for lubricating purposes.	Number of holes.	Position of holes.
Cradle.....	10	3 on each side for howitzer slide, 1 in each side at front end for lubricating recuperator slide, and 2 in cradle cap for lubricating variable recoil gear.
Gear, brake.....	2	1 in each crosshead.
Gear, elevating: Arc.....	1	Over trunnion.
Gear, operating sight: Bracket supporting sight.	1	In top of bearing.
Gear, quick-loading.....	5	1 on right plunger socket, 2 on left plunger socket, and 1 in each side of bracket cross shaft.
Gear, traversing: Case, spur wheel and pinion.	3	1 for spur wheel, 1 for pinion, and 1 for bearing handwheel spindle.
Cover, traversing screw...	2	
Link nut.....	1	
Top carriage: Trunnion caps.....	2	1 in each cap.
Case, elevating and traversing gears.	7	1 for worm, 1 for worm spindle, 1 for handwheel bearing, 1 for spindle arc pinion, 1 for bearing of sight bracket, and 2 in clip portion of case.
Clip, rear right.....	2	1 at each end.

SIGHTING GEAR.

The carriage is provided with the following sighting arrangements. On the left side: Sight, rocking bar; panoramic sight, model 1917. On the right side: Dial sight.

SIGHT-OPERATING GEAR.

(Plate XI.)

The sights on the left side are moved through the same angle as the howitzer by means of a parallel motion operated from the elevating arc. For convenience in laying the sights are placed as far back as possible, and, as they can not be attached to the cradle, the parallel motion is necessary to transmit the motion from the elevating gear to the sights. When the quick-loading gear is worked, no movement of the sights takes place, as the cradle is then unlocked from the elevating arc, but on working the elevating gear the arc is moved, which, transmitting its movements to the link and rod, causes the sight to be rotated on its pivot. The upper end of the link on the elevating arc is formed into a crosshead, which is slotted to take a sliding bush held in position by two adjusting screws. The screws pass through the front and rear of the crosshead, and their points bear against the bush. By

PLATE XV

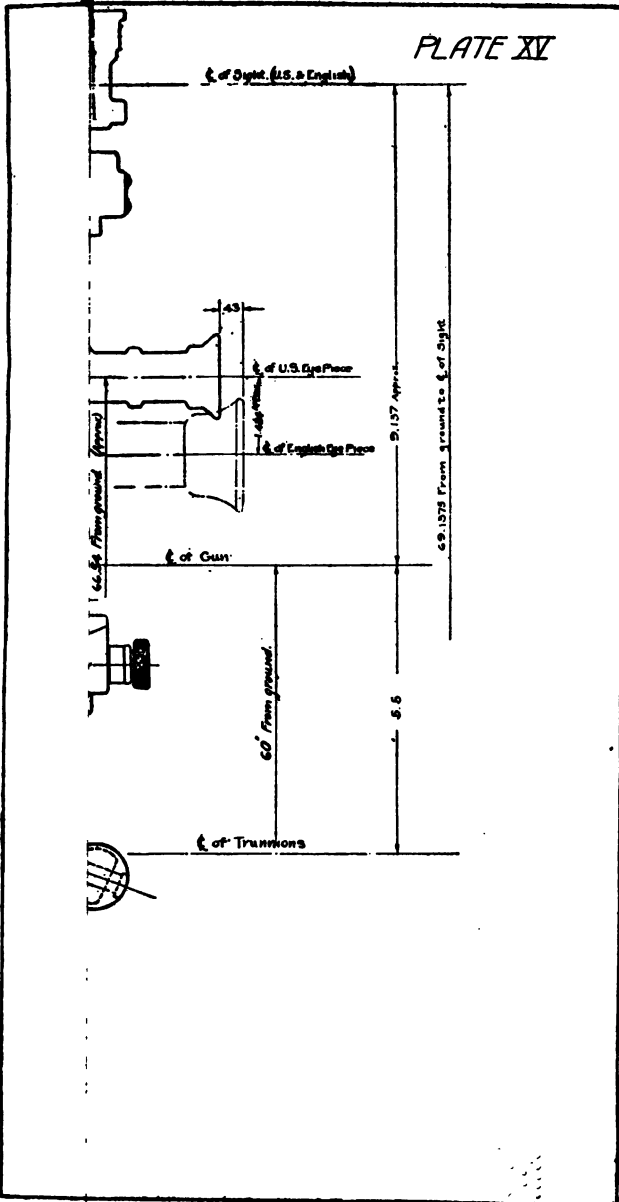
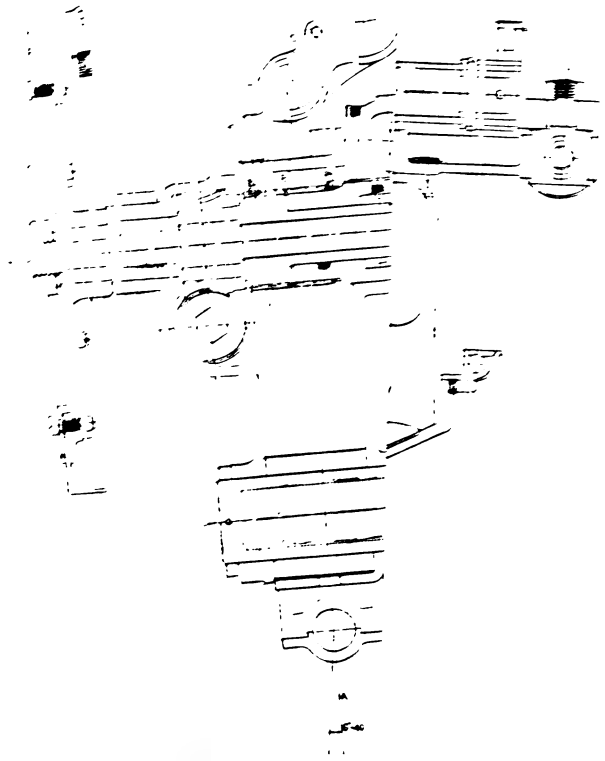

PLATE 2



C
C

I
8
I
t
t
8
I
I

FIGURE 26. (To face page 39)

means of the bush and screws, the sight is adjusted for elevation. To the sliding lock is attached the end of the connecting rod, the rear end of which is attached to the top of the sight bracket by a front and rear securing nut. By adjusting these nuts, the correct length of the rod for the proper movement of the sight is obtained, when the sight is first set up, or on repair.

SIGHT, ROCKING BAR.

(Plates XV and XVI.)

The site bracket is pivoted at its lower end to a bracket on the top carriage and is fitted with bearings to which is pivoted an oscillating bracket, which can be rocked in a plane at right angles to the axis of the piece by the cross-leveling gear. The latter consists of two nuts and a screw with a milled head, and is interposed between the oscillating and sight bracket, a cross level carried on the rear of the sight bracket indicates when the sight is level transversely. The difference in the elevation of the wheels is taken care of by this level. The oscillating bracket is in the form of a casing, and carries the sight gear, which is protected by a cover secured to the casing by screws.

The sight gear consists of a quadrant or range bracket pivoted at its lower end inside the oscillating bracket; the quadrant is provided with an internal toothed rack. Gearing into the rack is a pinion carried on a cross spindle on the outer end of which is secured the range drum. Between the drum and pinion, a spindle carries a worm wheel, into which gears a worm on the upper end of an oblique spindle, at the lower end of which is the handwheel for actuating the gear. To allow for any lost motion between the rack and pinion being taken up, the pinion is made in two parts. These are so arranged that one may be slightly rotated in relation to the other and locked.

Ball bearings are interposed between the worm and its bearings to reduce the friction caused by end thrust.

The range drum is fitted with a degree scale plate graduated to 50°, the graduations being indicated by a pointer on the oscillating bracket. The scale plate is held in position by a clamping ring with screws.

Brackets on the quadrant support the sight clinometer, sight bar, and carrier for panoramic sight.

The sight bar is a tubular steel bar pivoted horizontally near its front end through an eccentric bush in the bracket on the quadrant, in which it is secured by a washer, nut, and pin. The front end of the bar carries an adjustable acorn foresight, protected when not in use by a cap with chain, while its rear end is slotted to fit over a projection on the deflection nut.

In a bracket on the right side is cut a V notch for use in conjunction with the acorn foresight. The deflection gear is carried in a crosshead formed at the rear of the quadrant, and consists of a screw with a milled head, nut in two parts of the spring, scale plate, and graduated drum. The scale plate is attached by screws to the back of the crosshead, the graduations having a value of 10 mils, being indicated by an arrow on the nut. The drums fit over the end of the screw, and are also graduated in tenths of a mil, with indicating arrows on the crosshead.

CLINOMETER SIGHT.

(Plate XV.)

The sight clinometer is used to give the "angle of site," and admits of 300 mils elevation or 300 mils depression. It is constructed so that it may be readily attached to the rocking-bar sight. It consists principally of a cradle with a worm spindle, and a toothed arc with a spirit level. The cradle is fitted on the underside with spring clips for fixing it to a bracket on the quadrant, and with radial grooves on top, in which the arc slides; the worm spindle passes through the center of the cradle, and is supported at each end by movable bearings, one of which is pivoted to the cradle, and the other free to slide in grooves for a limited distance, so that the worm on the spindle may be readily disengaged from the teeth in the arc when necessary for quick adjustment. The worm is kept up to its work by a flat spring with a bearing surface on its underside, and each end of the spindle is fitted with an adjustable micrometer collar marked to read in mils. The arc consists of a toothed segment with a spirit level above; it slides in the grooves on the cradle and the teeth engage in a worm on the spindle; an adjustable pointer is fitted below the level for reading the degrees of elevation and depression engraved on the cradle.

DIAL SIGHT.

The dial sight consists of a circular carrying plate with a scale ring graduated in mils, a crosshead and pin, and a sight plate with pointer. The carrying plate is hinged at the center to the crosshead, and the crosshead is hinged transversally to the crosshead pin. This arrangement permits an adjustment right and left to compensate for any difference that may occur in the level of the wheels and for elevation or depression being given to the plate and sight. The scale ring is fixed to the periphery of the carrying plate by screws; and is graduated in mils. Should it be found, by examination, that when the sight line and the axis of the gun are parallel, zero is not indicated, the pointer is so adjusted as to admit of the required adjustment being made. The sight

plate is pivoted to the center of the carrying plate and joined near its center, the joint pin is provided with a thumb nut for clamping the plate in the extended or folded position; the plate is fitted with an acorn—pointed foresight at the front end, and notched to form a hind sight at the rear end. A clamping screw is provided to fix the sight plate at the required angle. The sight is fixed to the bracket by a crosshead pin, which fits into a corresponding socket on a pillar and is secured by a keep pin.

PANORAMIC SIGHT, MODEL OF 1917.

(Plate XVII.)

The panoramic sight is a vertical telescope so fitted with an optical system of reflecting prisms and lenses that the gunner with his eye at the fixed rubber eyepiece (RE) can bring into the field of view an object situated at any point in a plane perpendicular to the axis of the telescope.

OPTICAL SYSTEM.

The rays coming from the object are reflected downward from the rotating head prism (RHP) into the rotating prism (RP). The rotating prism (RP) rectifies the rays; after their passage through the achromatic objective lens (OL), the lower reflecting prism (LRP) reflects them in such a way that there is presented to the eye lens (EL) a reflecting image, which the eyepiece magnifies. A characteristic of the rotating prism is that upon rotation about its longitudinal axis the image of the object seen through it turns with twice the angular velocity of the rotating prism. The rotating head prism and rotating prism are so mounted as to rotate about this axis, the rotating prism following the rotating head prism with one-half of the angular velocity of the latter, the image always remains as it would appear to one observing it directly with an ordinary telescope. The image formed by the achromatic objective lens (OL) would then be reversed and inverted. The rays are cross reflected to the opposite sides of the axis by the inclined faces of the lower reflecting prism, thus correcting the reversal.

The combined action of the rotating head prism (RHP), the rotating prism (RP) and lower reflecting prism (LRP) and the nature of action varying with different positions of the prisms provide for the correction of the inversion of the image. The rotating head prism (RHP) and lower reflecting prism (LRP) as shown in position on Plate XVII act as parallel reflectors and they without the lens system would present an erect image. The rotating prism (RP), however, inverts the rays and corrects the inversion produced by the achromatic objective lens (OL). It will be noted that the effect would be the same whether the

rotating prism (RP) occupies the same position shown on the plate or be revolved 180° from that position.

The rotating head prism (RHP) must be turned through 360° to get a position of 180° for the rotating prism (RP). If the rotating head prism (RHP) is rotated through 180° , the rotating prism (RP) and lower reflecting prism (LRP) would form reflectors set at right angles, and would give, without the lens system, an inverted image, and in conjunction with the lens system an erect image. The rotating prism (RP) in this case will occupy a position of 90° from that shown on the plate, in which position it causes no inversion but counteracts the inversion produced by the lower reflecting prism (LRP).

The instrument has a magnifying power of 4 and a field view of 10° .

THE PRINCIPAL PARTS.

The principal parts of the panoramic sight are the rotating head mechanism, the elevating device, the azimuth mechanism, the rotating prism mechanism, the counting device, the shank, and the elbow.

ROTATING HEAD MECHANISM.

The rotating head mechanism consists principally of the rotating head (RH), rotating head prism (RHP), rotating head prism holder (Y), prism holder cover (C2), elevation index support (G2), prism shield (S1), and rotating head cover (C1).

The rotating head (RH) forms a housing for its movable parts, and provides seats for the elevation-worm ball socket and cap (2B and 1B), and rotating head prism holder (Y). The front opening of the rotating head is closed by the prism shield (S1), which forms a dust guard. The bottom threaded seat of the rotating head screws upon the upper end of the azimuth circle (J), and is locked in place by four rotating head retaining screws (1A). Upon the rear face of the rotating head (RH) is engraved a scale (G3), which is used for measuring the elevation of the rotating head prism holder (Y), which retains the rotating head prism (RHP), and has an index mark upon the projection coinciding with the graduations of the elevation micrometer (R1), thus measuring the angle of site.

The rotating head prism (RHP) is mounted within the rotating head prism holder (Y) between the prism support front (S), prism support bottom (T), and prism support back (X), and is secured in position by the rotating head prism spring (X1), which bears upon the prism support back (X). The rotating head prism (RHP) is protected on the right side by the prism holder cover (C2) and on the left side by the elevation index support (G2). The movement of the rotating

PLATE XVII

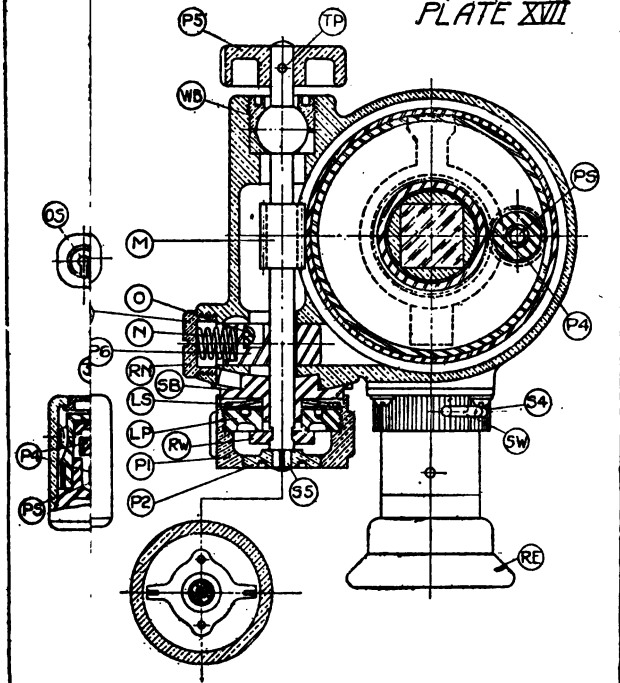

(RE)

NOTE: SCREWS MARKED (AS) MAY BE ADJUSTED IN SERVICE. ALL OTHER ADJUSTMENTS TO BE MADE BY THE ORDNANCE DEPARTMENT ONLY

MODEL OF 1917

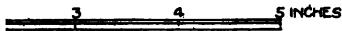

CLASS 36 DIVISION 15, DRAWING 23

head prism holder (Y), upon which the elevation segment (WS) is cut, is accomplished by the elevation worm (E1), and the length of travel is controlled by seven brass stop rings (R2). Each ring has a small tongue, the edge of which engages at each revolution of the elevation worm (E1) with the tongue on the adjacent ring. Each ring is thus engaged in its turn until six revolutions have been made, when the tongues are all in contact, and no further movement can be made in that direction.

The prism shield (S1) is held within the rotating head (RH) by the prism shield retaining piece (3A), which is in turn secured by two prism shield retaining piece screws (2A).

The prism holder cover (C2) screws into its threaded seat located in the right side of the rotating head prism holder (Y) and is locked in position by the prism holder cover screw (C3).

The rotating head cover (C1) screws into its threaded seat located in the right side of the rotating head (RH) and is held in place by the rotating head cover screw (S7). The exterior of the rotating head cover (C1) has two small holes for teat wrench, and engravings "Field 10°" and "Power 4" are located on the exterior surface.

The elevation index support (G2) screws into its threaded seat located in the left side of the rotating head prism holder (Y), and is secured in place by the elevation index support screw (G7). The small holes in the exterior surface allow the use of a teat wrench, to enable the elevation index support (G2) to be screwed in place. The support retaining ring (G4) retains the elevation index support with rotating head prism holder within the rotating head and is locked in position by the supporting ring screw (G5).

The elevation index (G6) is held upon the elevation index support (G2) by the two elevation index retaining screws (G8). The arrow engraved upon the German-silver piece which is dovetailed in the elevation index (G6) coincides with the graduations of the scale (G3) engraved upon the rear face of the rotating head (RH).

ELEVATION DEVICE.

The elevation device consists principally of the elevation segment (WS), elevation worm (E1), elevation worm ball cap and socket (1B and 2B), elevation worm plunger spring and plug (S3 and B2), elevation micrometer (R1), seven stop rings (R2), and elevation index (G6).

The elevation segment (WS) is hobbled into the rotating head prism holder (Y) and meshes with the elevation worm (E1).

The elevation worm (E1) is mounted in the back of the rotating head (RH) in a ball and socket bearing (2B), which in conjunction with

the elevation worm plunger spring (S3) and plunger (E2) prevents back lash between the elevation worm (E1) and the elevation segment (WS).

The elevation micrometer (R1) is held upon the upper slotted end of the elevation worm (E1) by the micrometer locking screw short (S2). The scale engraved upon the periphery is graduated into 100 equal divisions, numbered every 10 divisions. The upper exterior diameter of the elevation worm micrometer head is straight knurled to facilitate turning. One complete revolution of the elevation micrometer (R1) is equal to the distance between each graduation upon the scale (G3) on the rear face of the rotating head. Each graduation represents 100 mils, and the scale (G3) is so planned that the line of sight is horizontal when it reads 3.

OPEN SIGHT.

The open sight (OS) is constructed of bronze plate bent to shape, having an arm projecting out at each end, each arm containing a hole. A bronze knee is soldered to the interior of the front projecting arm over the center of the hole in such a manner as to form a sight which is used for quick sighting. The open sight (OS) is secured to the rotating head cover by two open-sight retaining screws.

AZIMUTH MECHANISM.

The principal parts of the azimuth mechanism are the azimuth circle support (I), azimuth circle (J), azimuth worm (M), bearing socket (WB1), and bearing cap (WB), throw-out plunger (P6), and spring (N), spring plate for azimuth circle (K), azimuth circle hood (AH), azimuth micrometer (P1), azimuth index (A4), and micrometer index (P2).

The azimuth circle support (I) screws on the shank (G), to which it is pinned by two dowels (D). The rotating prism held by a screw in its holder is screwed into the supporting sleeve (P3) and then placed in the shank (G). The azimuth circle (J) rests on the tapering wall of the azimuth circle support (I) being held in place by the spring plate for azimuth circle (K) which along with the azimuth circle hood (AH) forms the rotating parts of the azimuth mechanism. The spring (K) furnishes the necessary friction between the azimuth circle and the azimuth circle hood (AK). In the left side of the azimuth circle hood (AH) the azimuth worm (M) is held in a ball and socket joint (WB) so that by means of a throw-out cam (O) the worm (M) is thrown out of mesh with the azimuth circle (J) for quick adjustment in sighting, but is normally held in mesh with the throw-out plunger (P6) and spring (N).

The German-silver strip on the bottom of the azimuth circle is divided into 64 equal divisions and each even number is numbered. As each complete turn of the azimuth worm (M) rotates the azimuth circle (J) one division, and the azimuth micrometer is graduated in 100 divisions, each division on the azimuth micrometer (P1) represents $1/6400$ of the circumference or 1 mil. Therefore an angular movement of one division on the azimuth micrometer causes a lateral displacement of so near $1/1000$ of the range that the difference is disregarded. Thus the numbers read through the azimuth circle window (AW) represent hundreds of mils, and the reading on the azimuth micrometer (P1) represent mils. On the azimuth micrometer starting from 0 in each direction, every tenth division is numbered in red or black, those in red giving left deflection and those in black right deflection. The micrometer index (P2) has two arrows, one marked "L" and the other "R," engraved on it; the "R" filled in in black and the "L" in red. The azimuth index arrow is filled in with black. As the micrometer index (P2) is fastened tightly to the azimuth worm (M) it must turn with it, but the azimuth micrometer (P1) does not as the locking spring (LS) and deflection locking plate (LP) prevent it from turning when the azimuth worm (M) is turned. As the azimuth micrometer (P1) may be turned independently of the worm (M) it can be so set as to be used for a counting device.

The shank (G) forms a body for the instrument and provides a seat for the azimuth circle support (I) to be doweled to and a thread at the lower end for the elbow (E5) to screw into. On the front of the shank (G) is a T lug (H) that fits into a T slot at the top of the rear sight in which it is held by a screw with knurled head.

ROTATING PRISM MECHANISM.

The rotating prism mechanism consists principally of the rotating prism (RP), rotating prism holder (PC), supporting sleeve for rotating prism (P3), and the pinions for rotating prism and rotating head (P4). The azimuth circle (J) is geared by means of two pinions (P4) turning on the pinion shaft (P5) set in the azimuth circle support (I), to the rotating prism holder (PC) so that the angular movement of the rotating head (RH) is twice that of the rotating prism holder (PC). The rotating prism (RP) is retained in the rotating prism holder (PC) by a set screw (RS) and a block (B3) cemented to the rotating prism (RP) after the prism is ground out to fit it.

ELBOW.

The principal parts mounted in the lower end of the elbow are the reticule (R), reticule cell (RC), achromatic field lens (FL), achromatic eye lens (EL), eye lens cell (EC), and rubber eyepiece (RE).

The achromatic objective lens (OL) is mounted in the upper end of the objective lens cell (LC). This cell is secured in its threaded seat in the upper end of the elbow (E) by two objective lens-cell retaining screws (CS).

The elbow is screwed in the lower end of the shank (G) and secured by the four elbow retaining screws (4ES) in such a manner that its projecting arm is perpendicular to the axis of the instrument.

The lower reflecting prism (LRP) remains stationary as it is firmly pressed against seats machined in the elbow (E) by a holder (X) fitted to a seat at the bottom of the elbow. The tension of this holder is regulated by a wedge (W) to the required amount. Upon the right side of the elbow (E) is an opening through which the light is thrown upon the reticule (R). This opening is covered by the window (SW) to protect the interior of the eyepiece from dust and dirt. The shutter (S) is so designed to slide over the opening in the elbow (SW), being guided by the shutter stop screw and movement limited by the elongated dot.

The reticule (R) has two cross lines etched on its surface and is mounted in the forward end of the reticule cell (RC), which is secured in the eye lens cell (EC) by the reticule cell retaining screw. The horizontal cross line of the reticule is graduated in mils.

The achromatic eye lens (EL) is mounted in the eye lens cell (EC) and is separated from the achromatic field lens (FL) by the lens separator (LS). The achromatic field lens (FL) is held within the eye lens cell (EC) by the field lens retaining ring (LSR), which in turn is held by the field lens cell retaining ring screw. The eye lens cell is secured to the elbow by the eye lens-cell retaining screw (ES).

All interior metallic surfaces exposed to the refracted light are finished with dull black baking enamel. All exposed optical elements, covers, and nonrotating joints are sealed with the litharge cement in equal. All German silver graduated surfaces are sandblasted and blued.

Zero screw marked (A) may be adjusted in service. All other adjustments to be made by the Ordnance Department only.

Nomenclature of parts of panoramic sight, model of 1917.

	Symbol.	Name of part.
1	AH.....	Azimuth circle hood.
2	AW.....	Azimuth circle window.
3	1A.....	Rotating head retaining screw.
4	2A.....	Prism shield retaining piece screw.
5	3A.....	Prism shield retaining piece.
6	A4.....	Azimuth index.
7	1B.....	Elevation worm ball cap.
8	2B.....	Elevation worm ball socket.
9	B3.....	Block in rotating prism.
10	CS.....	Objective lens cell retaining screw.
11	C1.....	Rotating head cover.
12	C2.....	Prism holder cover.
13	C3.....	Prism holder cover screw.
14	D.....	Dowel pin.
15	EC.....	Eye lens cell.
16	EL.....	Achromatic eye lens.
17	ES1.....	Eye lens cell retaining screw.
18	E1.....	Elevation worm.
19	E2.....	Worm plunger spring plug.
20	4ES.....	Elbow retaining screw.
21	E5.....	Elbow.
22	F.....	Reticule.
23	FL.....	Achromatic field lens.
24	G.....	Shank.
25	G2.....	Elevation index support.
26	G3.....	Scale.
27	G4.....	Support retaining ring.
28	G5.....	Support retaining ring screw.
29	G6.....	Elevation index.
30	G7.....	Elevation index support screw.
31	G8.....	Elevation index retaining screws.
32	H.....	"T" lug.
33	5HS.....	Azimuth circle hood screw.
34	I.....	Azimuth circle support.
35	J.....	Azimuth circle.
36	K.....	Spring plate for azimuth circle.
37	L.....	German silver strip.
38	LC.....	Object lens cell.
39	LRP.....	Deflection locking plate.
40	LRP.....	Lower reflecting prism.
41	LS.....	Locking spring.
42	LC3.....	Lens separator.
43	LR3.....	Field lens cell retaining ring.
44	M.....	Azimuth worm.
45	N.....	Spring.
46	O.....	Throw out cam.
47	OL.....	Achromatic objective lens.
48	OS.....	Open sight.
49	P.....	Throw out lever.
50	PC.....	Rotating prism holder.
51	PS.....	Pinion shaft.
52	P1.....	Azimuth micrometer.
53	P2.....	Micrometer index.
54	P3.....	Supporting sleeve for rotating prism.
55	P4.....	Pinions for rotating prism and rotating head.
56	P5.....	Azimuth worm knob.
57	P6.....	Throw out plunger.
58	RC2.....	Reticule cell.
59	RE.....	Rubber eyepiece.
60	RH.....	Rotating head.
61	RHP.....	Rotating head prism.
62	RN.....	Spring retaining nut.

TESTING AND ADJUSTING SIGHTS.

The adjustment of optical instruments must be made by mechanics assigned to the job. A warning label that will be attached to the work.

To set the range drum - Lay the leveling instrument by means of a level across the sight adjustment. Set the sight gear in slope. Range drum should have a reading zero if set, which is as follows:

Adjustment - Slacken the screws securing the remaining plate, revolve drum to zero and tighten screws.

2. The bubble of the cross level should be in the center of its run when the top of the sight is level transversely.

To - Place spirit level across the top of the panoramic sight socket having first removed the panoramic sight and bring the bubble of the level to the center of its run by working the cross leveling gear. The bubble of the cross level should now be in the center of its run. If it is not so, it must be adjusted by a mechanic from the Mobile Ordnance Repair Shop.

3. The bubble of the site clinometer should be in the center of its run and set at zero, with the bowtie laid horizontal and the range drum also set at zero.

-Place a spirit level on the top of the clinometer plane of and bring the bubble to the center of its run by working the

PLATE XVIII

TARGET F017 (VICKERS MARK VI)

NOTE: ated by

lights is parallel

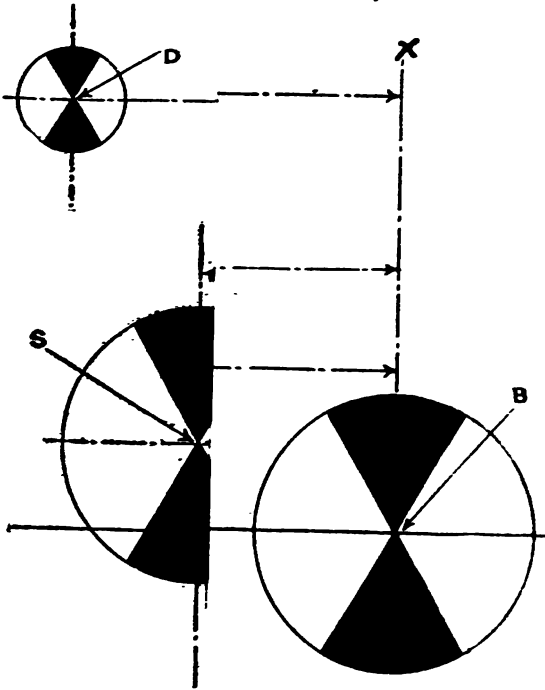

elevating gear of the carriage. Set site clinometer and range drum at zero. The bubble of the site clinometer should now be in the center of its run; if it is not, adjust as follows:

Adjustment.—Bring the bubble of the site clinometer to the center of its run by working the milled head. Slacken the screw securing the indicator of the mil scale and the nut securing the micrometer scales shift indicator and micrometer scales to zero and reclamp.

4. TO VERIFY PARALLELISM OF LINES OF SIGHT AND AXIS OF BORE.

The sights are correctly adjusted when, at zero elevation and deflection, the lines of sight are parallel to the axis of the bore.

When the carriage is placed with wheels on a level platform, the howitzer with axis of bore horizontal, and the sights at zero elevation and deflection, the points in which the lines of sight and the axis of the bore prolonged pierce a distant plane perpendicular to the latter should be located with reference to each other as indicated on Plate XVIII.

A target made according to the dimensions on Plate XVIII should be placed in a vertical position perpendicular to the line of sight at a distance of not less than 100 yards from the howitzer, and at such a height that the point B is at the same height as the axis of the bore of the howitzer. The verticality of the target should be assured by a plumb line attached at X and coinciding with the vertical line through B.

The carriage should be rested on carefully leveled solid supports; the howitzer should then be directed so that the axis of the bore, prolonged, pierces the target at the proper point. The lines of sight of the open and panoramic sights, if adjustment is true, should pierce the target in the points marked S and D, respectively.

In order to train the bore of the howitzer accurately on B, secure two threads or hairs at the muzzle, fastening them perpendicular to each other with the point of intersection coincident with the axis of the bore and sight through the axial vent of the breech mechanism.

In the field, where from lack of time or proper facilities the method just given can not be followed, the adjustment of the sights may be verified by bringing the lines of sight at zero elevation and deflection to bear upon some sharply defined point of a distant object. At such a range (for instance, 2,000 yards or more) the parallax may be neglected, and if the sights are correctly adjusted the lines of sight and the prolongation of the axis of the bore will sensibly pass through the selected aiming point.

The adjustment of the sights is of such importance and should be verified so frequently that battery commanders will find it advantageous to make permanent arrangements for such verification. The leveled supports constituting the carriage emplacement should preferably be of stone. The site of the target (Plate XVIII) should be prepared, and the exact locations of the target and horizontal reference points permanently marked. If these arrangements are properly made, subsequent verifications of sights will become a simple matter.

ADDITIONAL TESTS.

After the sights are adjusted they should be subjected to the following tests to insure their accuracy at extremes of elevation and azimuth:

(a) With carriage level and howitzer and sights at zero elevation and deflection the lines of sight and axis of bore prolonged pierce the target in the proper points.

(b) The howitzer is then moved to its maximum elevation; as the sight elevation is altered the lines of sight should follow the vertical lines through the same points of the target.

(c) With conditions as in (a) the howitzer is moved upon the carriage to its extreme positions in azimuth; as the sight deflections are now altered the lines of sight should follow the horizontal lines through the same points on the target.

By construction and assemblage the sights, if correctly adjusted, should fulfill the above conditions with substantial accuracy. If error be noted, a report of the facts of the case with the cause, if known, should be made to the ordnance officer charged with the repair of the matériel for his information and action.

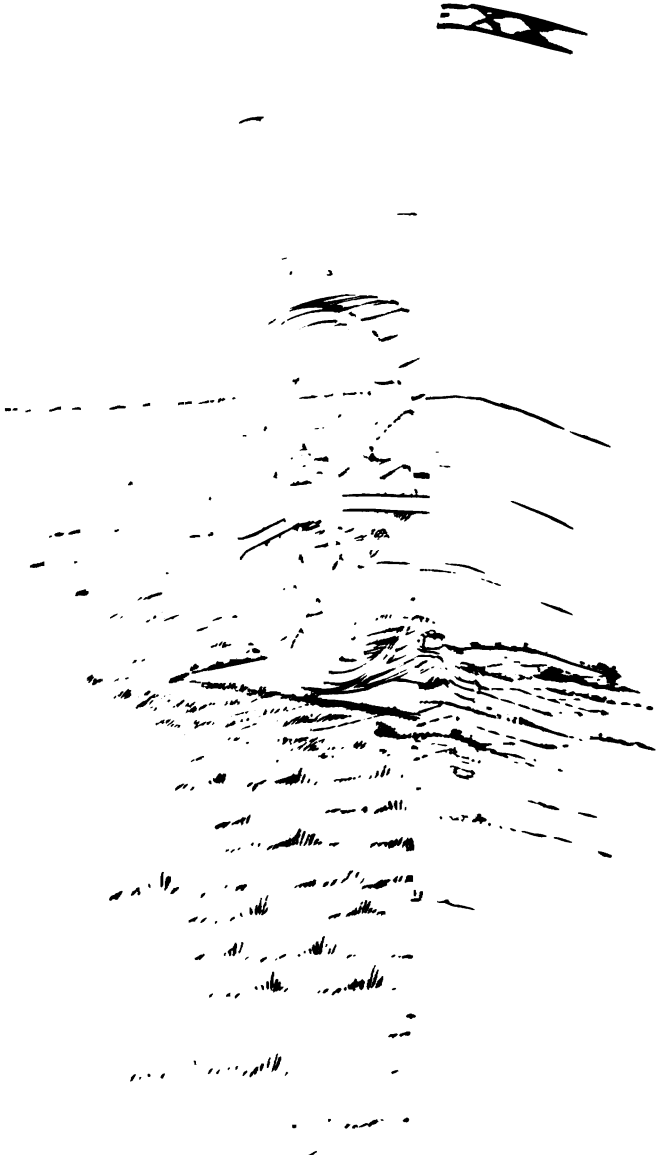

8-INCI

7100 19. (From page 51)



7100

FIRING PLATFORM FOR 8-INCH HOWITZER, MODEL OF 1917 (VICKERS).

DESCRIPTION.

The firing platform consists of a triangular frame of wood and steel, which is buried in the ground and is used for the following purposes:

1. To provide a reliable support for the wheels and the rear end of trail so as to prevent sinking or movement when firing on soft ground.
2. To insure the gun remaining on the target when firing.

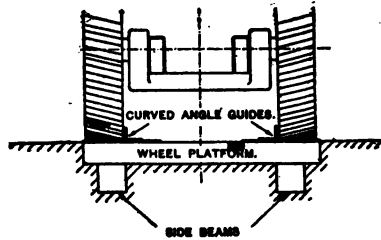

FIG. 7.

3. To provide a ready means of switching over through a total angle of 52° .

The principal parts are as follows:

- (a) Platform for wheels.
- (b) Side beams hinged together at front end and opened out in the form of a V.
- (c) Rear beam, made in two portions, top and bottom.

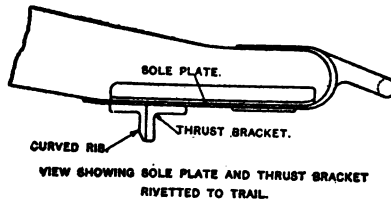
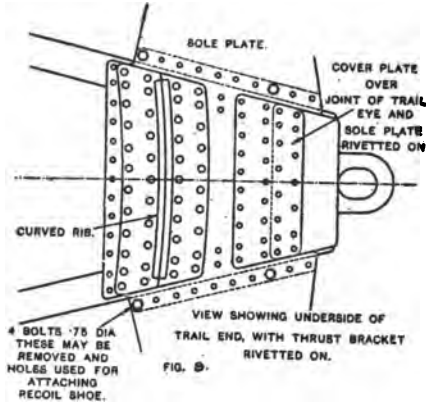

FIG. 8.

The platform for the wheels is placed near the apex of the triangle formed by the hinged and rear beams. The rear beams form the base, the upper one being curved at its front edge to form a guide when switching over the carriage.

The carriage wheels rest on steel plates on the wheel platform, and are guided by curved steel angles which prevent lateral movement of the gun off the target.



The wheel platform and rear beams are registered in position on the side beams by means of angle brackets. The rear beams are secured together by clamps at the ends and middle, and in addition a screw secures the upper rear beam to each side beam.

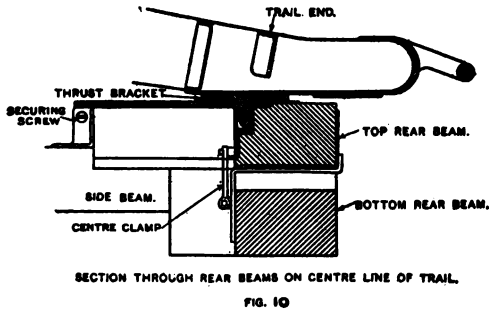

The trail is fitted with a sole plate and a thrust bracket bolted to the underside of the trail, instead of a spade. (See figs. 8 and 9.)

The thrust bracket is provided with a curved rib projecting down into a slot in the rear beam, which takes the thrust of the recoil and guides the trail end when switching from one position to another. (See fig. 10.)

PLATE XXI

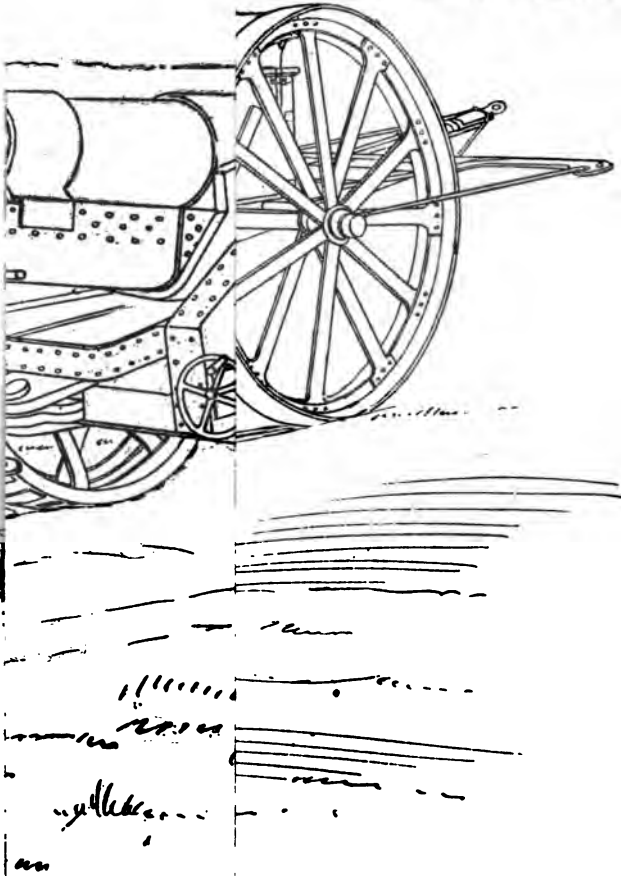

GE, MODEL OF
ING ARRANGEMENT.

PLATE XXII

og Beans.

***in the Rear Plate
og Pin, to enable
tined if desired.***



rs Mark VI).

The rear end of the trail is held in position laterally by a pin passing through the sole plate into holes in the rear beam. (See fig. 11.)

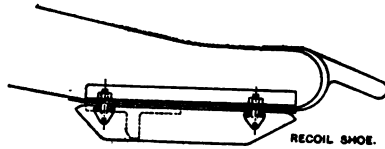
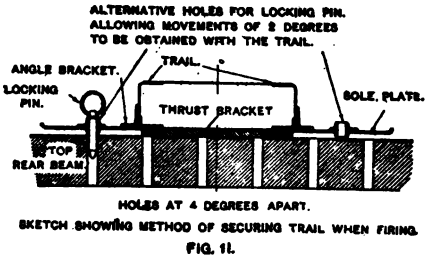

FIG. 12

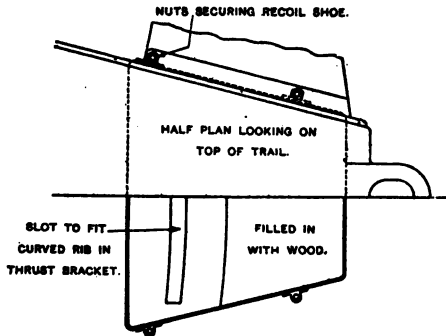

FIG. 13

The holes are provided at intervals of 4 degrees, and by using the alternative holes, one on each side of the sole plate, adjustments of 2 degrees may be obtained in the "switch over."

The limits of movement of the trail are 26° to right and left, and by using the traversing gear on the carriage a total traverse is obtainable of 30° breech right and breech left.

SECTION 1. HOW TO SET THE BEAMS OF SCORERS

The beams are set in position over the ground across a channel or a shallow trench in the ends of means of cables and pulleys.

.....	1.00
.....	1.10
.....	1.20
.....	1.30

The beams are placed in position on the ground across a channel or a shallow trench in the ends of means of cables and pulleys.

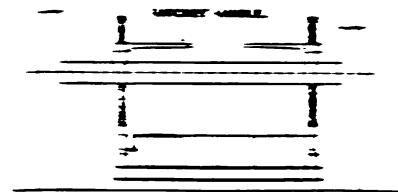

FIG. 4

The beams are placed in position on the end with corresponding supports to insure that they are laid together correctly.

The beams are then arranged into position over the beams, and secured in position in the channel bar by means of screws and nuts.

The beams are then secured in position by means of rope fasteners.

The beams are then secured in position behind the gun carriage.

The beams are then secured in position using small stakes, pegs, or other suitable means to the amount of excavating to that which is only indicated by the beams is shown.

The beams are then secured in position to the outlines and depths indicated.

EXCAVATING FOR FIRING BEAMS.

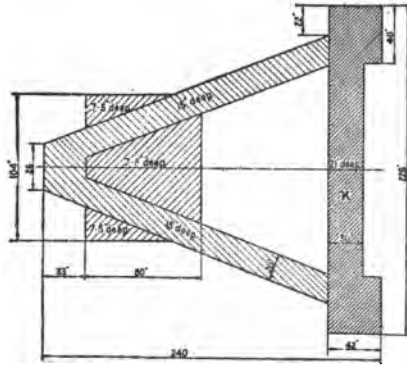

PLAN OF EXCAVATION.

FIG. 15

DISMANTLING TRAVELING LOAD.

(Plate XXIII.)

1. Remove the front platform A and place in readiness for putting in position on the beams later.

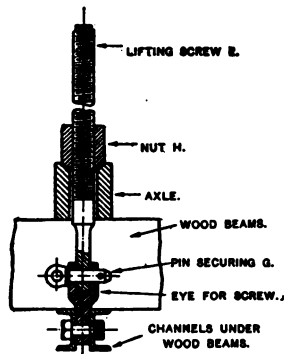

FIG. 16

2. Lower the remaining beams together to the ground by means of the two lifting screws E (Fig. 16), nuts H, and ratchet levers.

3. Remove the chain fastenings F at each end, disconnect the lifting screws E by taking out pins G, take away the wheels, axle and lifting screws, until required again for transporting.

ASSEMBLING BEAMS.

(Plate XXII.)

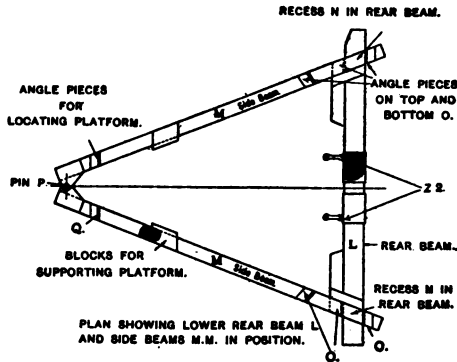

FIG. 17.

1. Place the lower rear beam L into the trench at K (fig. 15) by means of the handspikes and rope grummets provided. The clamp bolts Z1 (Plate XXII) should also be placed into position.

2. Lower the two side beams M into position with the rear ends resting on the rear beam, the exact position being located by the recesses N, in the rear beam, and the steel angles O on the side beams.

3. Secure the front ends of the side beams together by means of the pin P.

4. Remove the screwed pins Z3 and place into position the upper rear beam S, which is registered by the recesses cut into it for the side beams, and the steel angles O, which are secured to the side beams.

5. Clamp the upper and lower rear beams together, at the junction of the side beams, by means of the steel clamps Z and bolts Z1 at each end, and near the center, by means of the two links Z2.

6. Secure the upper rear beam to the side beams by means of the screwed pins Z3.

PLATE XXIII

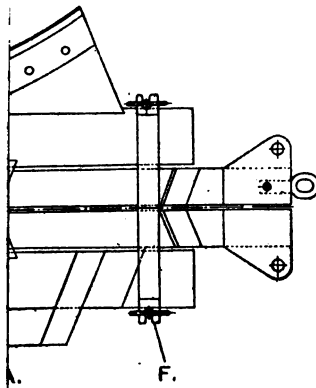
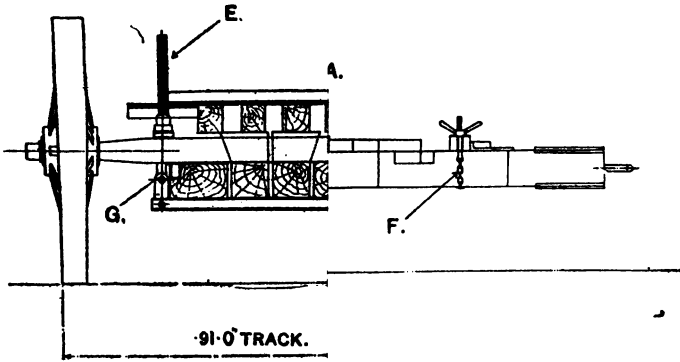

8-INark VI).



ASSEMBLING PLATFORM.

(Plate XXII.)

The front platform A may now be placed into position on the side beams with its forward end against the steel angles Q (fig. 17), the angles R on the platform registering it laterally.

FILLING IN AND LEVELLING THE GROUND.

Ram in the earth where required to make flush with the ground level, taking care to leave the ground cut away to clear breech end of gun at full recoil.

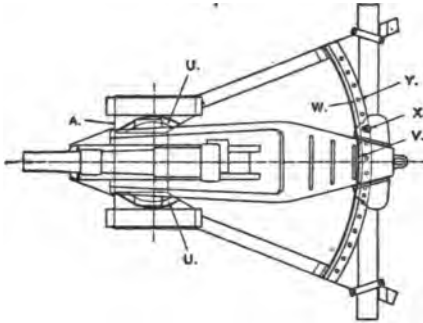

PLAN SHOWING CARRIAGE IN CENTRAL POSITION ON FIRING PLATFORM.

FIG. 18.

ASSEMBLING CARRIAGE ON BEAMS.

Wheel the carriage into position on the beams with the carriage wheels outside the angle guides U on the front platform A. Lower the rear end so that the curved rib V on the thrust bracket fits into the channel recess W in the top rear beam, then place the pin X in the trail into one of the holes Y in the rear beam to suit required position of traverse.

8-INCH HOWITZER CARRIAGE LIMBER, MODEL OF 1917 (VICKERS).

FRAME.

The limber consists of a framework which comprises four futchels of flanged steel connected by a trough-shaped splinter bar at the front and by a plate in the center and rear. To the back of the center futchels is riveted a steel limber hook with a key. Each center futchel is connected to the splinter bar by a diagonal stay.

AXLE AND WHEELS.

The axle is of steel, circular in section, with special wheel arms. It passes through bearings formed in the futchels and is held in position by brackets, which are keyed to the axle shoulders and bolted to the outside futchels. The outer end of each arm is prepared to take a cap with securing pin.

The wheels are of steel, 66 inches in diameter, having a tread of 6 inches. A grease cup is attached to each wheel.

The wheels are held on the axle arms by a drag washer, cap, and a pin which passes through the cap and axle arm and is held underneath by a split pin.

LIMBER CHEST.

The limber chest is of steel and is bolted to the top of the futchels. The lid is hinged at the front and secured in the rear by a hasp and padlock.

The top of the chest is fitted with handholds. There are also fittings on the side to take an ax, shovels, wrenches, etc. The chest is fitted internally to carry tools, spare packings for recoil cylinder and recuperator, obturator, etc.

DRAFT POLE.

The limber is equipped with a special cast-steel draft pole for motor traction.

MISCELLANEOUS TOOLS AND ACCESSORIES.

PROJECTILE BEARER.

The projectile bearer consists of a steel porter bar with handles and a pair of tongs of the toggle joint type. It is used to carry the projectiles from the supply to the loading tray.

PORTABLE AIR COMPRESSOR.

The air compressor is bolted to clips on the lower end of the trail when required for use, and is connected to the left air cylinder of the recuperator by means of a pipe. The piston is actuated by a crank shaft with winch handles transmitting motion to spur gearing.

The compressor is of the vertical two-staged type with high and low pressure cylinders. The low-pressure cylinder is provided with a suction valve fitted with an oil drip lubricator and is connected to the high-pressure cylinder by a short pipe fitted with an intermediate valve at either end. A delivery valve connects the high-pressure cylinder to the delivery pipe.

The cylinders are inclosed in a manganese bronze tank, which forms a water jacket for cooling purposes. The tank is provided with filling and drain plugs, and must be filled only when the compressor is in use.

A dust cover and two lifting bars are provided with the compressor. Two compressors are furnished with each battery of four guns.

OBTURATOR PRESS.

The press and gauge are for use in re-forming obturators which have become distorted. The press consists of a steel body, shaped internally to suit the contour of the obturator and fitted with a steel cover. The cover is secured by means of a steel bolt with disk spring washer and cross handle. The bolt is provided with a square head, by means of which the press can be held in a vise while the cross handle is revolved when compressing or releasing the obturator. A steel Tommy bar is provided for use with the cross handle in compressing the obturator. Recesses are formed around the periphery of the press so as to admit the application of the gauge for testing the thickness of the obturator while under compression.

The gauge is a flat steel plate and is used for testing the thickness of the obturator.

PORTABLE LIQUID PUMP.

This pump is used to fill the recoil cylinder and to charge the recuperator with liquid. It consists of a cylindrical galvanized iron tank provided with a lid. There are brackets inside the tank, in which the pump is secured by a bayonet joint. The pump proper consists of a vertical cylinder divided into two chambers, in one of which works a packed plunger actuated by handle at the top. The lower end of the pump is perforated for the entrance of liquid, which enters into the plunger chamber through an inlet valve. The bottom of the second chamber is fitted with a delivery valve and its top end has a threaded delivery nozzle, to which is attached a length of flexible hose, which connects the pump to the recuperator piston rod.

LOADING TRAY.

The tray is of steel semicircular in shape, fitted at the front end on the underside with a gun metal frame for engaging the lower interruptions in the breech opening. The rear end of the tray is turned up so as to form a stop against which the base of the projectile rests when being carried in the tray. It is provided on the underside with two brackets for the bearers. The bearers are tubular in section and are riveted to the brackets at the inner end; the outer ends are furnished with supporting brackets to facilitate handling. The outer ends of the bearers are provided with leather handgrips and wood plugs. The bearers are connected and the right and left sides by gun metal guide bar, which are shaped to rest on the side plates of the cradle to support the tray in the correct alignment for loading.

SYRINGE FOR EXTRACTING LIQUID.

The syringe consists of a body and spout of tin. In the body works a packed plunger. Its capacity is one-tenth pint of liquid. It is used to extract a small quantity of liquid from the recoil cylinder after the latter has been filled.

RAMMER AND SPONGE.

This combined tool performs the duty of a cleaner for the chamber in addition to that of rammer. The sponge portion consists of a bronze sleeve around which is fastened the sponge head, which is of maple. This head is covered with a closely woven covering of carpet. The rammer is made of manganese bronze and when used is screwed onto the end staff. The sponge is fitted to the staff in the same manner. The staff is in three pieces, which may be screwed into each other.

MEASURE FOR FILLING RECOIL CYLINDER.

This measure is of tin and holds 1 gallon. There are ribs around the inside surface by which 1 quart, 1 pint, one-half pint, and one-quarter pint may be measured. The lower end is provided with a spout and cock. It is fitted inside with a wire gauze strainer.

FIRE-CONTROL EQUIPMENT.

ARMY ARTILLERY.

Material.	Number per battery.
ORDNANCE PROPERTY.	
Prismatic compass.....	4
Hand clinometer.....	1
Stop watches.....	6
Periscope azimuth instrument.....	2
Azimuth instrument, ordinary drawing material.....	2
Set drawing instruments.....	1
Scale, equal parts, metric.....	1
Semicircular protractor (6-inch), graduated in mills.....	1
Metral arms, 1 meter long, graduated 1 to 20,000.....	3
Range and deflection board.....	1
Range tables.....	12
Battery commanders' telescopes, model 1915.....	1
ENGINEER PROPERTY.	
30-meter steel tapes.....	2
Stadia rod.....	1
Ranging rods.....	4
Plane table, 0.24 by 31, with declinator, open sight, and telescope alidade.....	1
Logarithmic tables, angular function mills.....	6
Transit.....	1
SIGNAL CORPS PROPERTY.	
Amplifiers, type 3, terret complete with $\frac{1}{2}$ volt and $\frac{1}{4}$ volt storage battery...	1
Axes, hand.....	8
Bags, tool, service.....	1
Bars, digging, standard.....	2
Batteries, extra tungsten, type A.....	9
Batteries, extra Eveready, No. 703.....	24
Batteries, extra Fda., T. M. signal lamps.....	5
Bells, vibrating, 110 chm. 15 volt.....	2
Belts, lineman's, with safety strap.....	1
Binding posts.....	15
Books, field message.....	10
Bulbs, extra, for flash lights.....	4
Cable 1 pair lead, kilometer.....	1
Carts, reel, hand.....	2
Climbers, pairs, with straps.....	1
Barometer graduated, millimeters and inches.....	1
Cross arms, 1 meter by 10 centimeters by 5 centimeters.....	140
Flash lights, electric, complete.....	9
Fuses, extra, 1-ampere, for 4 and 12 line boards.....	40
Glasses, field, Huet, 8-power.....	4
Grips, Buffalo, No. 2.....	1
Hammers, sledge.....	2

FIRE-CONTROL EQUIPMENT—Continued.

ARMY ARTILLERY—continued.

Material.	Number per bat- tery.
SIGNAL CORPS PROPERTY—continued.	
Hydrometer, Baumé.....	1
Insulators, clamp.....	16
Insulators, pigtail.....	100
Insulators, pony.....	23
Insulators, wooden knob, French type, 2.5 cm. high, with nails.....	220
Insulators, wooden knob, French type, 4.5 cm. high, with nails.....	640
Knives, electrician's.....	8
Lamps, signalling, type T. M. French.....	5
Marlin (pounds).....	5
Pliers, wire cutting, 8-inch.....	8
Megaphones.....	1
Nails, 10 cm. long, KG.....	2
Panels for heavy artillery, diamond shaped, adjacent angles 135° and 45°, each side 9 meters long, white.....	1
Panels, for heavy artillery, diamond shaped, adjacent angles 135° and 45°, each side 9 meters long, black.....	1
Panels, for heavy artillery, diamond shaped, adjacent angles 135° and 45°, each side 3 meters long, white.....	3
Panels, for heavy artillery, diamond shaped, adjacent angles 135° and 45°, each side 3 meters long, black.....	3
Panels, heavy artillery, rectangular, 9 m. by 3 m., 10 cm. diameter (sapinottes), white.....	3
Panels, heavy artillery, rectangular, 9 m. by 3 m., 10 cm. diameter (sapinottes), black.....	3
Poles, lance.....	100
Projectors, 14 cm. (packed 3 in cases with batteries), case.....	1
Pulley blocks, double W E. No. 760,330.....	2
Receiving sets, type "A," complete.....	1
Reels, breast, French type.....	1
Rope, 15 mm. diameter, meters.....	35
Screw drivers, 6-inch.....	4
Screws, lag, 10 mm. by 10 cm. (for cross arms).....	300
Screws, wood, 5 mm. by 50 mm., gross.....	2
Spoons, digging.....	1
Staples, insulated, Blake.....	400
Switchboard telephone, 4-line monotype.....	2
Switchboard telephone, 12-line monotype.....	1
Tape friction (pounds).....	3
Tape, rubber (pounds).....	2
Telephones, Model 1375-B.....	12
Watches, wrist, luminous, with wristlet.....	5
Wire, G. I., for guys, No. 12 KM.....	1
Wire, twisted, pair, outpost KM.....	8
Thermometers, Grad. Centigrade, Fahrenheit.....	2
Poles, 2.3 to 2.5 m. long, 10 cm. diameter (sapinotte).....	250

The fire-control equipment (as listed) is carried in compartments provided for the purpose on the telephone truck and reel truck, model of 1918. The trucks form part of the equipment and, together with the fire-control instruments for battery and headquarters company, are described and illustrated in Ordnance Office Pamphlet, Form No. 1796,

“Handbook of Fire-Control Equipment for Field Artillery.” The equipment issued to the headquarters company of a regiment of field artillery is listed in Form No. 1796.

A complete detailed description of the method of disassembling and adjusting the different instruments is given in Ordnance Office Pamphlet No. 1795, “Instructions for the Care, Preservation, Repair, and Adjustment of Instruments for the Fire-Control Systems for Coast and Field Artillery.”

No disassembling of instruments except as prescribed will be permitted. The disassembling of instruments allowed herein must be done only in the presence of a commissioned officer. Disassembling as permitted in Pamphlet 1795 must be done only by officers and employees of the Ordnance Department.

Statement of spare parts, tools, and accessories of one 8-inch howitzer battery, model of 1917 (Vickers, Mk. VI).

Article.	Number per battery.	Where carried.
TOOLS AND ACCESSORIES FOR HOWITZER.		
Gunner's quadrant.....	4	In limber box.
Wrench No. 137.....	4	Do.
Wrench No. 138.....	4	Do.
Thickness gauge, obturator.....	2	In supply truck.
Bronze reamer primer seat.....	8	In limber box.
Cold chisel.....	4	Do.
Screw driver, 10-inch.....	4	Do.
Copper hammer.....	2	In supply truck.
Gunner's punch.....	4	In limber box.
Gunner's drill.....	4	Do.
Large drift.....	4	Do.
Small punch.....	4	Do.
Cleaning reamer.....	4	Do.
Small drift.....	4	Do.
Wire-cutting pliers, 8-inch.....	4	Do.
Hand mallet.....	2	In supply truck
Lanyard.....	8	In limber box.
Ball peen hammer.....	4	Do.
File, three-cornered, 8 inches long, with handle.....	4	Do.
File, flat, 8 inches long, dead smooth, with handle.....	4	Do.
File, round, second cut, 8 inches long.....	4	Do.
File, round, smooth, 8-inch.....	4	Do.
File handles.....	28	Do.
File, half-round, smooth, 8 inches long.....	4	Do.
File, pillar No. 6, 6 inches long.....	4	Do.
File, three-cornered, No. 4.....	4	Do.
8-inch screw wrench.....	4	Do.
Obturator press, complete.....	4	Do.
Muzzle cover.....	4	On muzzle.
Breech cover.....	4	On breech.
Tool kit, No. 1.....	4	In limber box.
File kit.....	4	Do.
Bronze reamer case.....	4	Do.
Cover for gun.....	4	On gun.
Spare parts, pouch and rolls.....	4	In limber box.
SPARE PARTS FOR HOWITZER.		
Breech block rotating cam.....	1	In supply truck.
Rotating cam and control arc screw.....	6	Do.
Control arc.....	1	Do.
Rotating cam screw.....	1	Do.
Lever bearing.....	1	Do.
Crank shaft with nut and split pin.....	2	Do.
Bearing washer.....	4	Do.
Crosshead.....	2	Do.
Lever bearing securing bolt and split pin.....	2	Do.
Hinge pin and split pin.....	1	Do.
Lever catch plate screw.....	2	Do.
Spring retaining block securing pin.....	2	Do.
Lever catch.....	2	Do.
Catch plate.....	2	Do.
Lever catch retaining spring block.....	1	Do.
Lever catch spring.....	4	Do.
Lever arm.....	1	Do.
Obturator pad.....	8	Do.

Statement of spare parts, tools, and accessories of one 8-inch howitzer battery, model of 1917 (Vickers, Mk. VI)—Continued.

Article.	Number per battery.	Where carried.
TOOLS AND ACCESSORIES FOR CARRIAGE.		
Spanner No. 17.....	2	In supply truck.
Spanner No. 7.....	2	Do.
Spanner No. 2.....	2	Do.
Spanner No. 1.....	2	Do.
Spanner No. 3.....	4	In limber box.
Spanner No. 6.....	4	Do.
Spanner No. 4.....	4	Do.
Spanner No. 5.....	4	Do.
Tool for withdrawing split pins.....	4	Do.
Spanner No. 11.....	4	Do.
Spanner No. 9.....	4	Do.
Handspike.....	16	On trail.
Spanner No. 15.....	4	In limber box.
Spanner No. 10.....	4	Do.
Spanner No. 8.....	2	In supply truck.
Tommy bar, 8-inch.....	2	Do.
Spanner No. 12.....	2	Do.
Spanner No. 13.....	2	Do.
Spanner No. 16.....	2	Do.
Spanner No. 18.....	4	In limber box.
Spanner No. 19.....	4	Do.
Spanner No. 20.....	4	Do.
Screw driver sight gear.....	4	Do.
Spanner No. 23.....	4	Do.
Spanner No. 24.....	4	Do.
Tubular spanner.....	4	Do.
Spanner No. 21.....	2	In supply truck.
Tommy bar, large.....	4	In limber box.
Pressure gauge.....	2	In supply truck.
Adaptor washer.....	4	Do.
Adaptor.....	2	Do.
Cap adaptor.....	2	Do.
Adaptor pressure gauge.....	2	Do.
Washer, cap adaptor.....	2	Do.
Washer, adaptor.....	2	Do.
Lock, point adaptor.....	2	Do.
Oil strainer.....	2	Do.
Washer, plug adaptor.....	2	Do.
Plug adaptor.....	2	Do.
Filling measure.....	2	Do.
Do.....	2	Do.
Sight covers.....	4	On sights.
Horizontal oiler.....	4	On trail.
Oil cans, 6-quart.....	8	Do.
Tool kit No. 2.....	4	In limber box.
Tool kit No. 3.....	4	Do.
Carriage spare-part pouch.....	4	Do.
Trunnion roller-bearing pouch.....	4	Do.
Tin box for packing.....	4	Do.
Lubricating can No. 3.....	4	On limber box.
Case for lubricating can.....	4	Do.
Grease box, 3-pound.....	4	Do.
Clinometer, in case, assembled.....	4	On trail.
Air compressor, portable.....	2	In supply truck.
Air compressor connections.....	2	Do.
Bucket, water.....	4	Do.
Cleaning brush.....	8	Do.

Statement of spare parts, tools, and accessories of one 8-inch howitzer battery, model of 1917 (Vickers, Mk. VI)—Continued.

Article.	Number per battery.	Where carried.
TOOLS AND ACCESSORIES FOR CARRIAGE—contd.		
Cover for air compressor	2	On air compressor.
Lifting bar for air compressor	4	In supply truck.
Projectile bearer	8	On trail.
Air reservoir, filling recuperator	4	In supply truck.
Air reservoir adapter	2	Do.
Canvas roll for trunnion rollers	1	Do.
Pump, portable, liquid	2	Do.
Syringe, extracting, liquid	2	Do.
Stave, end, No. 15	4	On trail.
Staff, intermediate	4	Do.
Sponge and brush	4	Do.
Cose, steel, for panoramic sight	4	On carriage.
Rammer	4	On trail.
Straps	4	In limber box.
Loading barrow	4	On carriage.
Gunner's quadrant, model of 1897, with cose ¹	(1) 12	On vehicles.
Oil can	8	On carriage.
Outrigger stay	8	Do.
Outrigger	4	On trail.
Shovel, long	4	In supply truck.
Carriage spare parts roll	1	
TOOLS AND ACCESSORIES FOR LIMBER.		
Obturator box, complete	4	In limber.
Oil can, 8-quart	4	In limber box.
Paulin, 12 by 12 feet	4	On limber.
Lantern, complete	4	Do.
Lantern pads	4	Do.
Lantern straps	4	Do.
Limber spare part pouch	4	In limber box.
Pole prop	4	On limber.
Limber spare parts roll	1	In supply truck.
Straps:		
Blanket (paulin)	12	On limber.
Ax	4	Do.
Grease box	4	Do.
Pickax	4	Do.
Shovel, short	4	Do.
Pick mattock	4	Do.
Obturator box (this box is a spare accessory)	1	In supply truck.
Picket rope	4	Limber.
TOOLS AND ACCESSORIES FOR FIRING PLATFORM.		
Spanner No. 22	4	In limber box.
Spanner No. 25	4	Do.
Pickax	4	On limber box.
Short-handled shovel	4	Do.
Hatchet	4	Outside of limber box.
Ax	4	
Long-handled shovel	4	On trail.
Pick mattock	4	On limber.
Spanner, 26-inch	4	In limber box.
Tommy bar (spanner No. 26), 13-inch	4	Do.

¹ Two per battery.

Statement of spare parts, tools, and accessories of one 8-inch howitzer battery, model of 1917 (Vickers, Mk. VI)—Continued.

Article.	Number per battery.	Where carried.
TOOLS AND ACCESSORIES FOR SUPPLY TRUCK.		
Oil can, 7½-gallon (recoil cylinder).....	1	In supply truck.
Oil can, 7½-gallon (glycerin).....	1	Do.
Obturator box, complete.....	1	Do.
SPARE ACCESSORIES FOR CARRIAGES AND SPARE PARTS OF ACCESSORIES.		
Climometer assembled, in case.....	1	In supply truck.
Chest for spare sight.....	1	Do.
Air compressor connections.....	1	Do.
Chain, cap square, pin key.....	2	Do.
Chain, locking plate, left-hand recuperator.....	1	Do.
Chain, locking plate, right-hand recuperator.....	1	Do.
Chain, pin, air-compressor trail.....	1	Do.
Chain, lock bolt traveling lock.....	1	Do.
SPARE PARTS FOR CARRIAGES.		
<i>Recuperator.</i>		
Locking plate, air plug, right hand.....	4	In supply truck.
Washer air plug, air reservoir, right-hand side.....	13	Do.
Locking plate, front nut air reservoir.....	4	Do.
Locking plate, rear extension plug.....	2	Do.
Packing gland, front plug recuperator.....	16	Do.
Packing gland buffer plug.....	8	Do.
Locking plate front plug recoil cylinder.....	4	Do.
Locking plate front plug.....	4	Do.
Locking plate recuperator liners, rear end.....	4	Do.
Studs for locking plates.....	2	Do.
Neck ring air valves.....	4	Do.
Nut spindle air valves.....	4	Do.
Filling plug.....	4	Do.
Adapter front plug.....	2	Do.
Stud locking plate, rear.....	2	Do.
Leather ring, front plug recuperator.....	24	Do.
Breech nut.....	2	Do.
Recuperator rod nut front.....	8	Do.
Collar recuperator rod front.....	4	Do.
Rear nut, recoil cylinder piston rod.....	4	Do.
Front nut, recoil cylinder piston rod.....	4	Do.
Bearing strip for piston.....	4	Do.
Air and filling plugs for recoil cylinder.....	8	Do.
Screw securing pin bearing strip.....	12	Do.
Spring.....	8	Do.
Packing, garlock, rings.....	16	Do.
Recuperator rod leather, 0.187 ₁₆ " by 3.....	8	Do.
Collar recuperator rod, 0.187 ₁₆ " by 2.5.....	4	Do.
Rear nut recoil cylinder piston rod, 0.212 ₁₆ " by 3.5.....	4	Do.
Front nut recoil cylinder piston.....	4	Do.
Ring, packing for air valve (in tin box).....	4	Do.
<i>Cradle.</i>		
Nuts, hinge bolt cradle.....	2	Do.
Screw, for securing leather pad.....	1	Do.
Trunnion roller bearing, complete.....	4	Do.
Roller path trunnion roller bearing, outer.....	2	Do.
Roller path trunnion roller bearing, inner.....	2	Do.
Roller, trunnion bearing.....	64	Do.

Statement of spare parts, tools, and accessories of one 8-inch howitzer battery, model of 1917 (Vickers, Mk. VI)—Continued.

Article	Number per battery.	Where carried.
SPARE PARTS FOR CARRIAGES—continued.		
<i>Variable recoil gear.</i>		
Pin axes, rear connecting rod and split pin.....	4	In supply truck.
Pin spindle cut-off and split pin.....	4	Do.
<i>Elevating and traversing gear.</i>		
Pivot nut gear box.....	4	Do.
Ball thrust washer.....	1	Do.
Nut spindle-worm elevating and split pin.....	2	Do.
Nut pinion elevating and split pin.....	4	Do.
Locking-plate bushing.....	2	Do.
Screw pointer, traversing.....	4	Do.
Collar securing sight-operating bracket.....	4	Do.
Traversing pointer screws.....	4	Do.
Traversing pivot nut top carrier.....	4	Do.
<i>Quick-loading gear.</i>		
Bushing bracket plunger.....	1	Do.
Pin rod fork end front and split pin.....	4	Do.
Fork end front rod.....	4	Do.
Fork end rear rod.....	4	Do.
Pin rod fork end rear and split pin.....	4	Do.
Nut for plunger bracket.....	4	Do.
Spring for quick-loading gear.....	12	Do.
<i>Top carriage.</i>		
Locking screw key pin.....	2	Do.
<i>Travelling lock.</i>		
Locking pin, trail travelling lock.....	4	Do.
<i>Brake.</i>		
Brake blocks.....	12	Do.
Nut, spindle and brake gear.....	2	Do.
Washer, spindle brake gear.....	6	Do.
Coach screw, brake block.....	12	Do.
Nut, pin brake gear and split pin.....	4	Do.
Nut, pin hanger and split pin.....	4	Do.
Nut, spindle brake gear.....	2	Do.
Bolt brake bracket.....	4	Do.
Collar rocking pin.....	6	Do.
<i>Trail.</i>		
Pin, T draft.....	4	Do.
Nuts, axle bolt (sets).....	1	Do.
Nuts, bolt axle (set).....	1	Do.
Washer, bolt axle.....	18	Do.
Wheels, carriage, complete.....	2	Do.
Do. securing air compressor, with chain.....	4	Do.
Do. securing angle stiffener to spade.....	8	Do.
Do. for bolts.....	8	Do.
Do. nuts.....	2	Do.
Do. firing pin, trail, firing platform.....	2	Do.
Do. transom bolts.....	2	Do.
Do. locking pin, trail.....	4	Do.

Statement of spare parts, tools, and accessories of one 8-inch howitzer battery, model of 1917 (Vickers, Mk. VI)—Continued.

Articles.	Number per battery.	Where carried.
SPARE PARTS FOR CARRIAGES—continued.		
<i>Loading barrow.</i>		
Loading barrow, complete.....	1	In supply truck.
<i>Sight.</i>		
Sight, complete.....	1	Do.
Nut, securing cotter.....	2	Do.
Eye fore-sight cap.....	2	Do.
Nut, clamping screw.....	2	Do.
Bolt for gear case 6.2 long.....	2	Do.
Nuts for gear-casing bolts.....	3	Do.
Bolts for gear casing.....	4	Do.
<i>Split pins.</i>		
0.062 $\frac{1}{4}$ by 1.25.....	10	Do.
0.093 $\frac{1}{4}$ by 1.5.....	10	Do.
0.125 by 1.75.....	25	Do.
0.187 $\frac{1}{4}$ by 1.5.....	15	Do.
0.187 $\frac{1}{4}$ by 2.5.....	15	Do.
0.187 $\frac{1}{4}$ by 3.25.....	10	Do.
<i>Rivets.</i>		
Button head:		
0.25 by 2, pound.....	1	Do.
0.375 by 1.75, pound.....	3	Do.
0.437 $\frac{1}{4}$ by 2.25, pound.....	4	Do.
0.5 by 2, pound.....	5	Do.
Countersunk head:		
0.187 $\frac{1}{4}$ by 1.75, pound.....	1	Do.
0.75 by 2.5, pound.....	1	Do.
0.375 by 2, pound.....	2	Do.
0.5 by 1.5, pound.....	3	Do.
0.5 by 4, pound.....	5	Do.
0.625 by 2, pound.....	3	Do.
0.75 by 3.5, pound.....	5	Do.
CARRIAGE SPARE PARTS CARRIED IN LEATHER POUCH.		
Fiber washer, air and filling plug.....	16	In limber box.
Leather washer plug adapter front plug.....	8	Do.
Spring recuperator gland.....	8	Do.
Spring throttle valve.....	8	Do.
Adjusting plug retarding.....	4	Do.
Washer plug recuperator.....	16	Do.
Washer plug retarding.....	8	Do.
Packing, front plug recuperator cylinder.....	2	Do.
Packing, front plug recoil cylinder.....	2	Do.
Spring, recoil cylinder.....	4	Do.
Joint ring, steel.....	2	Do.
Joint ring, leather.....	8	Do.
U ring, leather.....	16	Do.
Screw securing bracket, connecting rod.....	4	Do.
Screw cover, gear box traversing.....	4	Do.
Screw securing locking plate bush.....	4	Do.
Screw scale, elevating.....	4	Do.
Screw pointer, elevating.....	4	Do.
Screw scale, traversing.....	4	Do.
Spring plunger, left hand.....	4	Do.
Spring plunger, right hand.....	4	Do.
Screw securing bracket, quick loading gear.....	4	Do.
Guide pin for bracket.....	4	Do.
Screws for lever bracket cover.....	4	Do.
Screw securing cover, elevating and traversing gear.....	8	Do.

Statement of spare parts, tools, and accessories of one 8-inch howitzer battery, model of 1917 (Vickers, Mk. VI)—Continued.

Article.	Number per battery.	Where carried.
CARRIAGE SPARE PARTS CARRIED IN LEATHER POUCH—continued.		
Screw securing guide gun carriage bracket.....	4	In limber box.
Locking bolt.....	4	Do.
Locking pin, traveling.....	6	Do.
Belleville spring washer.....	6	Do.
Screw, clamping.....	4	Do.
Handle, clamping screw.....	1	Do.
SPARE PARTS FOR CARRIAGE LIMBERS.		
Bolts, axle flange outer with nuts.....	16	In supply truck.
Pins, axle cap with split pins.....	8	Do.
Pin, coupling engine draft.....	4	Do.
Wheels, limber complete.....	2	Do.
Pin, draft pole.....	4	Do.
Key, split flat.....	4	Do.
Chain, key split flat.....	4	Do.
Outrigger, part 1 (1 off, 1 near).....	4	Do.
Eye, chain.....	4	Do.
Stay, outrigger.....	1	Do.
Key, outrigger, complete.....	4	Do.
Pin, joint outrigger.....	8	Do.
Burr, joint pin, outrigger.....	12	Do.
Key, limber hook.....	4	Do.
Loop, singletree, middle.....	4	Do.
Loop, singletree, end.....	8	Do.
Pin, connecting pole and split pin.....	4	Do.
Lunette pin 3.8 long.....	4	Do.
Lunette pin 3.9 long.....	4	Do.
Draft link pin.....	2	Do.
Connecting pole.....	2	Do.
Tie, outrigger stay.....	1	Do.
Bolt, axle tree band with nuts.....	4	Do.
Bolt, stay with nuts.....	4	Do.
<i>Split pins.</i>		
0.125 by 2.....	20	Do.
0.187 $\frac{1}{4}$ by 3.25.....	20	Do.
<i>Rivets.</i>		
Button head:		
0.25 by 1.75 (pound).....	1	Do.
0.375 by 1.5 (pound).....	3	Do.
0.5 by 1.5 (pound).....	3	Do.
Countersunk head:		
0.25 by 1.5 (pound).....	1	Do.
0.375 by 2 (pound).....	2	Do.
Tube rivets.....	8	Do.
SPARE PARTS FOR FIRING PLATFORM.		
Axle.....	1	Do.
Eyes for lifting screw.....	4	Do.
Bolt, lifting screw eye.....	2	Do.
Pin, lifting eye.....	2	Do.
Nut, lifting screw eye.....	6	Do.
Firing platform lifting screw eye.....	2	Do.
Washer seat.....	2	Do.
Seat, lifting screw.....	6	Do.
Sleeve, lifting screw.....	6	Do.
Traveling instruction plate.....	1	Do.
Chaws, securing instruction plate.....	2	Do.

INDEX.

	Page.
Additional powder increments.....	16
Air cylinders.....	26
Air pressure, to test.....	28
Ammunition.....	15
Components.....	15
Description.....	15
Packing for shipment.....	18
Weight of complete round.....	15
Axle.....	21
Axle bracket.....	21
Brake gear.....	21
Breech mechanism.....	9
Care and preservation of.....	14
To remove.....	12
Breech ring.....	8
Carriage.....	19
Care and preservation.....	29
Description.....	19
Principal parts.....	20
Weight, dimensions, etc.....	19
Cartridge.....	16
Contents, list of.....	5
Cradle.....	36
Draft link.....	21
Elevating gear.....	36
Care of.....	36
Elevating scale.....	29
Equipment, list of.....	61
Equipment pertaining to one 8-inch howitzer battery on war footing.....	7
Fire-control instruments.....	60
Firing mechanism.....	11
Firing platform.....	50
Fuze.....	17
Description.....	17
Parts, list of.....	17
Howitzer.....	7
Breech mechanism.....	9
Care of the.....	14
Description.....	8
Weights, dimensions, ballistics, etc.....	7
Hydraulic recoil cylinder.....	25
L leather packing.....	25
Assembling.....	29
To replace.....	30

	Page.
Limber.....	57
Liquid.....	31
Recoil cylinder.....	29
Recuperator.....	30
Loading tray.....	59
Lubricating holes on carriage, list of.....	37
Lubricators in breech mechanism, list of.....	14
Measure for filling recoil cylinder.....	60
Miscellaneous tools and accessories.....	58
Misfires and hangfires.....	19
Obturation.....	10
Obturator pad.....	10
Obturator press.....	58
Obturator channel, to clean.....	14
Packing, to replace.....	29
Packing cap, to tighten.....	29
Panoramic sight.....	40
Description.....	40-45
Nomenclature of parts.....	46
Percussion and firing mechanism.....	11
Piston rods.....	34
Piston-rod packing, replacement of.....	34
Pivot pin.....	21
Plates, list of.....	6
Portable air compressor.....	58
Portable liquid pump.....	59
Powder.....	16
Powder chamber.....	9
Precautions.....	30
Primer.....	15
Projectile.....	17
Common steel shell.....	17
Projectile bearer.....	58
Quick-loading gear.....	23
Description.....	23
Action of.....	24
Rammer and sponge.....	59
Recoil cylinder.....	29
Care of.....	29
To empty.....	29
To fill.....	29
Recoil cylinder and recuperator, action of.....	27
Recoil indicator.....	23
Recoil valve.....	26
Recuperator.....	30
Care of.....	30
General instructions for care of.....	34
To charge with compressed air.....	33
To empty.....	34
To fill.....	32
To make up the pressure after leakage.....	34

	Page.
Recuperator piston.....	35
Assembling leather "U" rings.....	36
To replace leather "U" rings.....	36
To replace packing.....	36
Sighting gear.....	37
Additional tests.....	49
Clinometer sight.....	39
Dial sight.....	40
Sight-operating gear.....	38
Sight, rocking bar.....	38
Testing and adjusting.....	47
Spade.....	21
Syringe for extracting liquid.....	59
Trail.....	21
Top carriage.....	22
Traveling lock.....	24
Traversing gear.....	22
Traversing scale.....	23
Variable recoil mechanism.....	26
Wheels.....	21

WAR DEPARTMENT,
 OFFICE OF THE CHIEF OF ORDNANCE,
 Washington, January 15, 1918.

Form No. 1798.
 Ed. Jan. 15, 1918—2,000.

○

NOT 1 1918



