

UNCLASSIFIED

AD NUMBER
AD909917
NEW LIMITATION CHANGE
TO Approved for public release, distribution unlimited
FROM Distribution authorized to U.S. Gov't. agencies only; Test and Evaluation; JAN 1973. Other requests shall be referred to Commander, Naval Weapons Laboratory, Dahlgren, VA 22448.
AUTHORITY
NWL ltr dtd 29 Aug 1973

THIS PAGE IS UNCLASSIFIED

AD909917

DOCUMENT TRANSMITTAL
NDW-NWL-5605/1 (6-71)

CLASSIFICATION	AD NUMBER (To be inserted by DDC)	REPORT SERIES AND NO.
UNCLASS. WHEN ENCL. IS REMOVED	ORIGINATING AGENCY Naval Weapons Laboratory	TR-2242
SERIAL NO. (When required)/DATE	ENCLOSURE (Report title) SURVIVABILITY OF AIR LAUNCHED GUIDED WEAPONS IN A WIDE ENVIRONMENT	REPORT DATE January 1973 COG. NAVAIR CODE

TO [Administrator
Defense Documentation Center for Scientific and Technical Information (DDC)
Bldg # 5, Cameron Station
Alexandria, Virginia 22314]

CONTRACT/PROJECT/AIRTASK NUMBER				
SECURITY CLASS.	UNCL	CON	SECRET	RD
REPORT	y			
TITLE OR SUBJECT	y			
ABSTRACT OR SUM.	y			

Enclosure is forwarded for distribution subject to limitations checked below. Request AD number be inserted in space above; two copies of this letter be returned to originating activity if shown below; two copies be sent to Commander, Naval Air Systems Command; and one copy be retained by DDC.

- A. Approved for public release; distribution unlimited.
- B. Distribution limited to U. S. Govern. agencies only:
Test and Evaluation: January 1973.
Other requests for this document must be referred to Commander,
Naval Weapons Laboratory, Dahlgren, Virginia 22448.

[Publications Branch
Naval Weapons Laboratory
Dahlgren, Virginia 22448]

SIGNATURE *R. W. Franklin* TITLE Head, Publications Branch
R. W. FRANKLIN

[Commander
Naval Weapons Laboratory
Dahlgren, Virginia 22448]

CODE	DATE
CLASSIFICATION	
UNCLASSIFIED	
UNCLASSIFIED WHEN ENCLOSURE IS REMOVED	

NWL TECHNICAL REPORT TR-2943
January 1973

SURVIVABILITY OF AIR LAUNCHED GUIDED WEAPONS IN A FIRE ENVIRONMENT

by

J. A. Robinson

Test and Evaluation Department



Distribution limited to U. S. Government agencies only; Test and Evaluation; January 1973. Other requests for this document must be referred to the Commander, Naval Weapons Laboratory, Dahlgren, Virginia 22448.

FOREWORD

This work was accomplished under AIRTASK No. A532-532D/291-2/1501-0000-02 by the Naval Weapons Laboratory, Dahlgren, Virginia.

The report has been reviewed by the following personnel of the Test and Evaluation Department:

H. P. Caster, Head, Weapons Evaluation Division

F. W. Kasdorf, Assistant Head, Test and Evaluation Department

Released by:

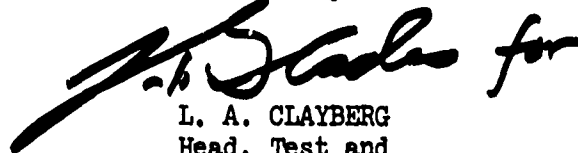
A handwritten signature in black ink, appearing to read "L. A. Clayberg for". The signature is written in a cursive style and is positioned above the printed name and title.

L. A. CLAYBERG
Head, Test and
Evaluation Department

ABSTRACT

Tests were conducted to establish fast cook-off characteristics of the following guided weapons: (a) SIDEWINDER (AIM-9), (b) WALL-EYE (MARK 1 MOD 0), (c) SPARROW III (AIM-7), and (d) SHRIKE (AGM-45A). The type of reaction that occurred, the time to reaction and time-temperature data were obtained for each guided weapon when engulfed in fire from burning JP-5 fuel. These data are applicable to the design of thermal protection systems and the development of safer fire fighting procedures.

CONTENTS

	<u>Page</u>
Foreword	i
Abstract	ii
Introduction	1
Purpose	1
Fast Cook-Off Test Facilities	1
Test Configuration and Procedures	5
Instrumentation	5
Results	5
SIDEWINDER (AIM-9)	6
WALLEYE (MARK 1 MOD 0)	6
SPARROW III (AIM-7)	6
SHRIKE (AGM-45A)	7
Conclusions	7
SIDEWINDER (AIM-9)	7
WALLEYE (MARK 1 MOD 0)	7
SPARROW III (AIM-7)	8
SHRIKE (AGM-45A)	8
Recommendations	8
References	9
Apendices:	
A. Definitions of Reactions (for Guided Weapons) ..	A-1
B. Fast Cook-Off Data Summary	B-1

CONTENTS (CONTINUED)

	<u>Page</u>
C. Fast Cook-Off Test Data Sheets, Photographs and Time-Temperature Data	
SIDEWINDER (AIM-9)	C-1
WALLEYE (MARK 1 MOD 0)	C-8
SPARROW III (AIM-7)	C-12
SHRIKE (AGM-45A)	C-20
D. Distribution	D-1

INTRODUCTION

The major aircraft carrier fires that occurred in recent years aboard the USS FORRESTAL and the USS ENTERPRISE exposed a deficiency in the knowledge of hazards associated with flame envelopment of navy air launched weapons. Reference (a) tasked the Naval Weapons Laboratory to investigate these hazards by subjecting fleet used weapons to simulated carrier flight deck fires (fast cook-off tests). Under this task, two tests were conducted on each of the following:

- a. SIDEWINDER (AIM-9)
- b. WALLEYE (MARK 1 MOD 0)
- c. SPARROW III (AIR-7)
- d. SHRIKE (AGM-45A)

PURPOSE

Fast cook-off tests were conducted to obtain the time to reaction, the type of reaction and time-temperature data for selected air launched weapons. The data were required for the design of thermal protection systems and the development of safer fire fighting procedures.

FAST COOK-OFF TEST FACILITIES

The tests were conducted in the following facilities:

- a. Fast cook-off test retainer cage:

Figure 1 is an overall view of the retainer cage. It was used to prevent missile fly-away in the event of a design mode reaction. The cage had a 30-foot square base and encaged a 20-foot square test pit. Figure 2 shows the stand used to restrain the missiles during tests.

- b. Fast cook-off test open pit:

Figure 3 is a view of the open pit. It was used to test the WALLEYE guided weapons which are not designed to react propulsively. The walls of the pit were banked to a height of approximately eight feet, and the pit contained a 30-foot square burning surface.



PHD-0801-4-73

Figure 1

27 October 1972

Fast cook-off test retainer cage used to test the guided missiles.

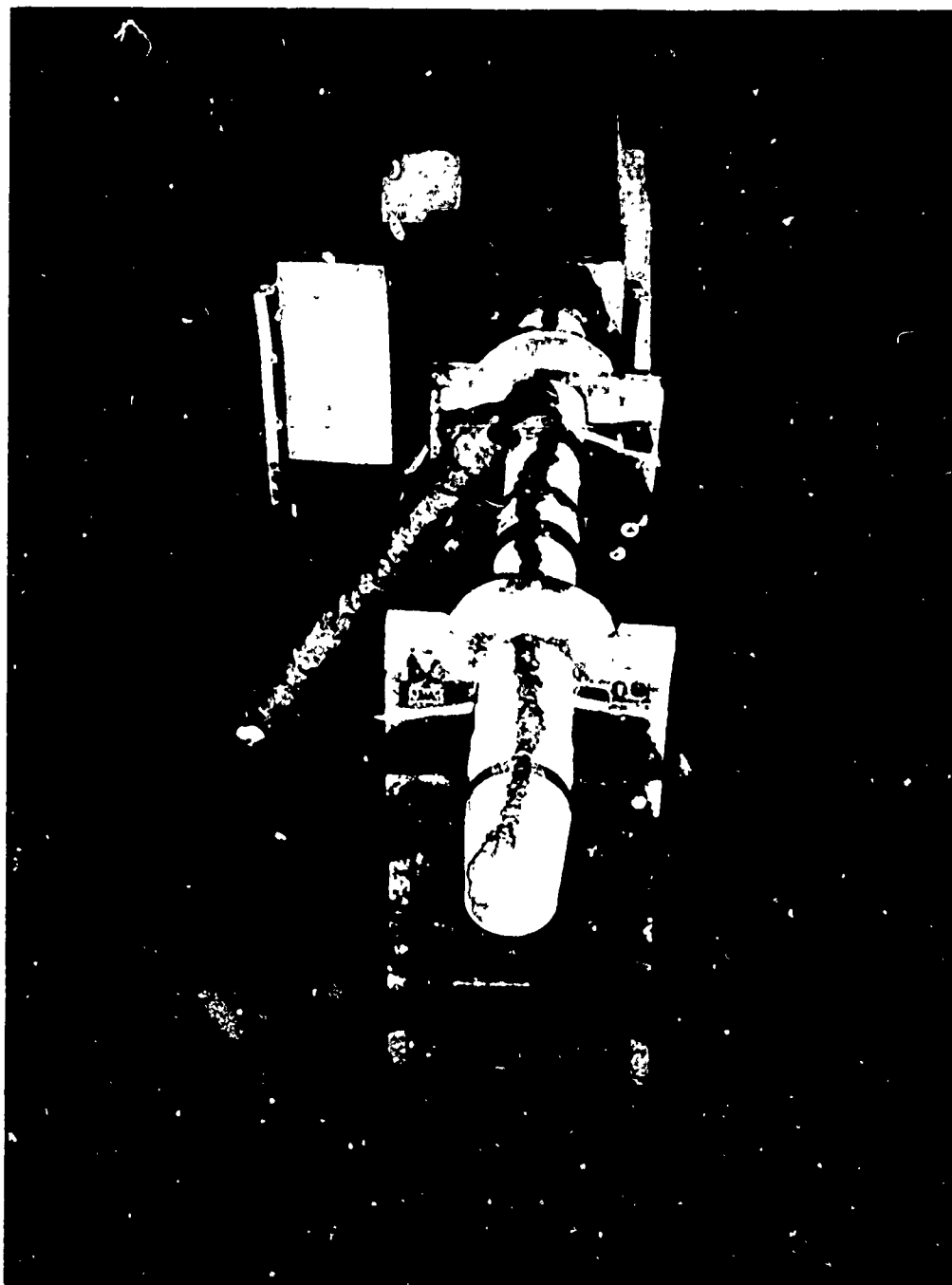

PHD-0802-4-73

Figure 2

14 December 1972

Stand used to restrain the missiles within the retainer cage.



PHD-0803-4-73

Figure 3

27 October 1972

Open pit used for fast cook-off tests of the WALLEYE guided weapons.

TEST CONFIGURATION AND PROCEDURES

Previous tests on air launched weapons, reported by reference (b) and (c), were conducted with active rocket motors and igniters and simulated warheads, boosters and safe and arm devices; or with active warheads, boosters, and safe and arm devices, and simulated rocket motors and igniters. For these tests, all propulsive and explosive components of the weapons were active. The weapons were not equipped with wing and fin assemblies due to difficulty in obtaining these components. Guidance and control units were simulated when not available.

The fuel pits were filled with approximately two inches of water to provide a level surface on which to float the jet aircraft fuel. The weapons were placed in a horizontal attitude, 36 inches (at the weapon centerline) above the water surface.

The necessary amount of jet aircraft fuel (JP-5) to ensure an explosive reaction was supplied to the fuel pit. To facilitate rapid fuel ignition, gasoline was poured over the fuel surface and thermite grenades (one placed in each corner of the fuel pit) were electrically initiated to ignite the fuel.

The tests were designed to provide: (a) Flame engulfment within 30 seconds (time to 1000°F average flame temperature), and (b) an average flame temperature of at least 1650°F.

INSTRUMENTATION

The data acquisition system consisted of iron-constantan thermocouples, an electronic temperature reference junction and an oscillograph. The system was used to measure the temperature of the flame environment about the missiles and the temperature of internal missile components (when possible).

Documentary high speed movie cameras, a video recorder and a black and white still camera were used on all tests.

RESULTS

Definitions of reactions used in this report are presented in Appendix A. A listing of the weapons tested and corresponding reaction times are provided in Appendix B. The detailed data, including time-temperature histories and pre-test and post-test photographs are

presented in Appendix C. Test results for each weapon tested were:

SIDEWINDER (AIM-9)

The shortest time to reaction for the SIDEWINDER missiles was 59 seconds. The most severe reaction was a motor explosion.

a. Test No. GM-1: The motor exploded in the vicinity of the aft hanger, separating the motor at approximately 18 inches from the aft end. This initial reaction occurred at one minute seven seconds and was immediately followed by propulsive burning which would have allowed the missile to thrash about if it had not been restrained. At two minutes 58 seconds into the test, the warhead deflagrated through the forward closure. There was no other explosive reaction.

b. Test No. GM-2: The rocket motor deflagrated at 59 seconds of flame exposure. This initial reaction was immediately followed by a chuffing action. The warhead and the safe and arm device were thrown off the test stand into the fuel pit. These items did not react.

WALLEYE (MARK 1 MOD 0)

The most severe reaction observed during the WALLEYE tests was a partial detonation. The shortest reaction time was two minutes 57 seconds.

a. Test No. GM-3: The warhead deflagrated at three minutes 30 seconds. The warhead ruptured at the rear end and burned for two minutes 49 seconds before partially detonating. The blast from the detonation caused considerable damage to the test stand. Burning pieces of explosive were thrown about the test site to a radius of 1200 feet. A number of grass fires were started by the burning explosive.

b. Test No. GM-4: The warhead deflagrated at two minutes 57 seconds. The booster deflagrated at five minutes 30 seconds.

SPARROW III (AIM-7)

The shortest reaction time of the SPARROW III missiles was one minute 31 seconds. The most severe reaction was a warhead detonation.

a. Test No. GM-5: The motor deflagrated at two minutes three seconds and burned violently. The warhead, the safe and arm device

and the booster all deflagrated separately and very mildly at 16 minutes three seconds, 20 minutes 54 seconds and 22 minutes seven seconds, respectively.

b. Test No. GM-6: The motor deflagrated at one minute 31 seconds after the start of the test. The warhead detonated at 15 minutes 41 seconds.

SHRIKE (AGM-45A)

Both SHRIKE warheads tested exploded. The shortest time to reaction was one minute 17 seconds.

a. Test No. GM-7: The motor deflagrated at one minute 44 seconds and the warhead exploded at one minute 57 seconds.

b. Test No. GM-8: The warhead exploded at one minute 17 seconds. The motor deflagrated at one minute 29 seconds.

CONCLUSIONS

SIDEWINDER (AIM-9)

a. The missile will deflagrate or explode in a flight deck fire.

b. If unrestrained, the missile will thrash about as a result of the MARK 36 MOD 0 motor reaction.

c. The motor and warhead will react in less time than the five minute minimum time requirement of reference (d).

WALLEYE (MARK 1 MOD 0)

When exposed in a flight deck fire, the MARK 1 MOD 0 WALLEYE guided weapon can be expected to react:

a. In less time than the five minute minimum time requirement of reference (d).

b. So as to create a major hazard to items in the immediate area.

c. So as to kindle new fires with burning explosive that is thrown about.

SPARROW III (AIM-7)

When the SPARROW III missile system is subjected to a fast cook-off environment, it can be expected to:

- a. React in less time than the five minute minimum time requirement of reference (d).
- b. Cause extensive blast and fragment damage.
- c. Enhance existing fires.

SHRIKE (AGM-45A)

It is concluded that when the SHRIKE AGM-45A missile system is exposed in a flight deck fire environment:

- a. Reaction will occur in less time than the five minute minimum time requirement of reference (d).
- b. The MARK 68 MOD 0 warhead will explode.
- c. Additional fires will be started by scattered fragments and burning explosive.

RECOMMENDATIONS

It is recommended that a retro-fix program be initiated for all fleet used air-to-air or air-to-ground guided weapons. The objective of the program would be to extend the minimum time to reaction to five minutes without increasing the severity of the reaction. It is recommended that the application of an insulating liner between the explosive and the weapon's case and the application of an intumescent heat retardant paint on the external surface of each weapon be investigated as possible fixes. The external thermal protection system would have to be extremely smooth, thin and tough to avoid adverse effects on handling and aerodynamic performance.

It is further recommended that two of each type of these air launched guided weapons be thermally protected using the techniques described above and subjected to fast cook-off tests. The weapons should be instrumented prior to being loaded. The data obtained would be used to verify the adequacy of the thermal protection system.

REFERENCE

- a. AIRTASK 430-303/291-1/W46430-00, work request No. WR-1-8093.
- b. Rocket Motor Survivability in Fire, C. P. Hontgas, NWL Technical Report TR-2508, November 1970.
- c. Rocket and Missile Warhead Survivability in Fire, W. D. Smith, NWL Technical Report TR-2848, October 1972.
- d. Naval Weapons Cook-Off Program Plan, First Revision, September 1969.

APPENDIX A

DEFINITIONS OF REACTIONS (FOR GUIDED WEAPONS)*

Detonation (cook-off) - Munition performs in design mode. Maximum possible air shock formed. Essentially all of case broken into small fragments. Blast and fragment damage is at maximum. Severity of blast causes maximum ground crater or flight-deck hole capable by the munition involved.

Partial Detonation (cook-off) - Only part of total explosive load in munition detonates. Strong air shock and small as well as large case fragments produced. Small fragments are similar to those in normal munition detonation. Extensive blast and fragmentation damage to environment. Amount of damage and extent of breakup of case into small fragments increases with increasing amount of explosive detonated. Severity of blast could cause large ground crater, or large flight-deck hole on carrier if munition is large bomb; hole size depends on amount of explosive that detonates.

Explosion (cook-off) - Violent pressure rupture and fragmentation of munition case with resulting air shock. Most of metal case breaks into large pieces which are thrown about with unreacted or burning explosive. Some blast and fragmentation damage to environment. Fire and smoke damage as in deflagration. Severity of blast could cause minor ground crater, or small depression on flight-deck of carrier if munition is large bomb.

Deflagration (cook-off) - Explosive in munition burns. Case may rupture or end-plates blow out; however, no fragmentation of the case. No fragments are thrown about. Damage to environment due only to heat and smoke of fire. No discernible damage due to blast or fragmentation.

*Definitions from NAVORD OP.5, VOLUME 1 THIRD REVISION

APPENDIX B

TABLE 1

AIR LAUNCHED GUIDED WEAPONS FAST COOK-OFF DATA SUMMARY

Test Number	Missile System	Missile Warhead	Rocket Motor	Fuze and/or Booster	Warhead Explosive Load	Motor Propellant	Time to Reaction Explosive (min:sec)	Time to Reaction Motor (min:sec)	Type of Reactions * (Explosive)	Type of Reactions & (propellant)
GM-1	SIDEMINDER (ADM-9)	MARK 48 MOD 4	MARK 36 MOD 0	MARK 13 MOD 0	PBXN-3(6 lbs)	RDS-500	2:58	1:07	Deflagration (WHD)	Explosion
GM-2	SIDEMINDER (ADM-9)	MARK 48 MOD 4	MARK 36 MOD 0	MARK 13 MOD 0	PBXN-3(6 lbs)	RDS-500	No Reaction	0:59	No Reaction	Deflagration
GM-3	WALLEYE (MK 1 MOD 0)	MARK 58 MOD 0	N.A.**	MARK 328 MOD 0 MARK 44 MOD 0	Comp-B(416 lbs)	N.A.	3:30 6:19	N.A.	Deflagration (WHD) Partial Detonation (WHD)	N.A.
GM-4	WALLEYE (MK 1 MOD 0)	MARK 58 MOD 0	N.A.	MARK 328 MOD 0 MARK 44 MOD 0	Comp-B(416 lbs)	N.A.	2:57 5:30	N.A.	Deflagration (WHD) Deflagration (Booster)	N.A.
GM-5	SPARROW III (ADM-7)	MARK 38 MOD 0	MARK 38 MOD 0	MARK 35 MOD 0 MARK 38 MOD 0	PBXN-101 (20 lbs)	MARK 75 MOD 0	16:03 20:54 22:07	2:03	Deflagration (WHD) Deflagration (SEA Device) Deflagration (Booster)	Deflagration
GM-6	SPARROW III (ADM-7)	MARK 38 MOD 0	MARK 38 MOD 0	MARK 35 MOD 0 MARK 38 MOD 0	PBXN-101 (20 lbs)	MARK 75 MOD 0	15:41	1:31	Detonation (WHD)	Deflagration
GM-7	SHRIKE (ACM-15A)	MARK 68 MOD 0	MARK 39 MOD 3	MARK 330 MOD 0 MARK 44 MOD 0	PBXN-101 (50 lbs)	MARK 76 MOD 2	1:57	1:44	Explosion (WHD)	Deflagration
GM-8	SHRIKE (ACM-15A)	MARK 68 MOD 0	MARK 39 MOD 3	MARK 330 MOD 0 MARK 44 MOD 0	PBXN-101 (50 lbs)	MARK 76 MOD 2	1:17	1:29	Explosion (WHD)	Deflagration

* Definitions from NAVORD OP5, Vol 1, Third Revision

** Not Applicable

APPENDIX C

SIDEWINDER MISSILE FAST COOK-OFF

Test No. GM-1

Data Sheet

Item Tested: SIDEWINDER AIM-9 Missile

Components: MARK 48 MOD 4 warhead containing 6 pounds of
PBXN-3 explosive
MARK 13 MOD 0 - Safe and Arm Device
MARK 36 MOD 0 - Rocket Motor
MARK 264 MOD 0 - Motor Igniter
Simulated - Guidance and Control Sections

Date of Test: 28 August 1972

Weather Conditions: Cloudy, 2-4 knots wind, temperature 75°F

Facility: 30' x 30' retainer cage with encaged fuel pit
and test stand, Figure 4

Fuel: 200 gallons of JP-5

Test Fire: Flame temperature exceeded 1000°F at 30 seconds
after fire ignition and averaged 1810°F during
the test.

Flame Duration: Six minutes

Results: A visual and audible reaction of the motor was
observed at one minute seven seconds into the
test. This was followed by a propulsive burning
of the motor. At two minutes 58 seconds into
the test, the warhead deflagrated and burned.

Inspection of the missile, after the test, showed
that the missile had exploded near the aft hanger.
Approximately 18 inches of the motor was missing
as shown in Figure 5. The motor reaction forced
the missile forward into the retainer stand.
Figure 6 shows an indentation on the retainer stand
that was caused by this reaction. The center of
the warhead section was bulged as shown in Figure 7.
The safe and arm device burned.



28 August 1972

Figure 4

SIDEWINDER AIM-9 Missile pre-test configuration.

C-2

PHD-0804-4-73

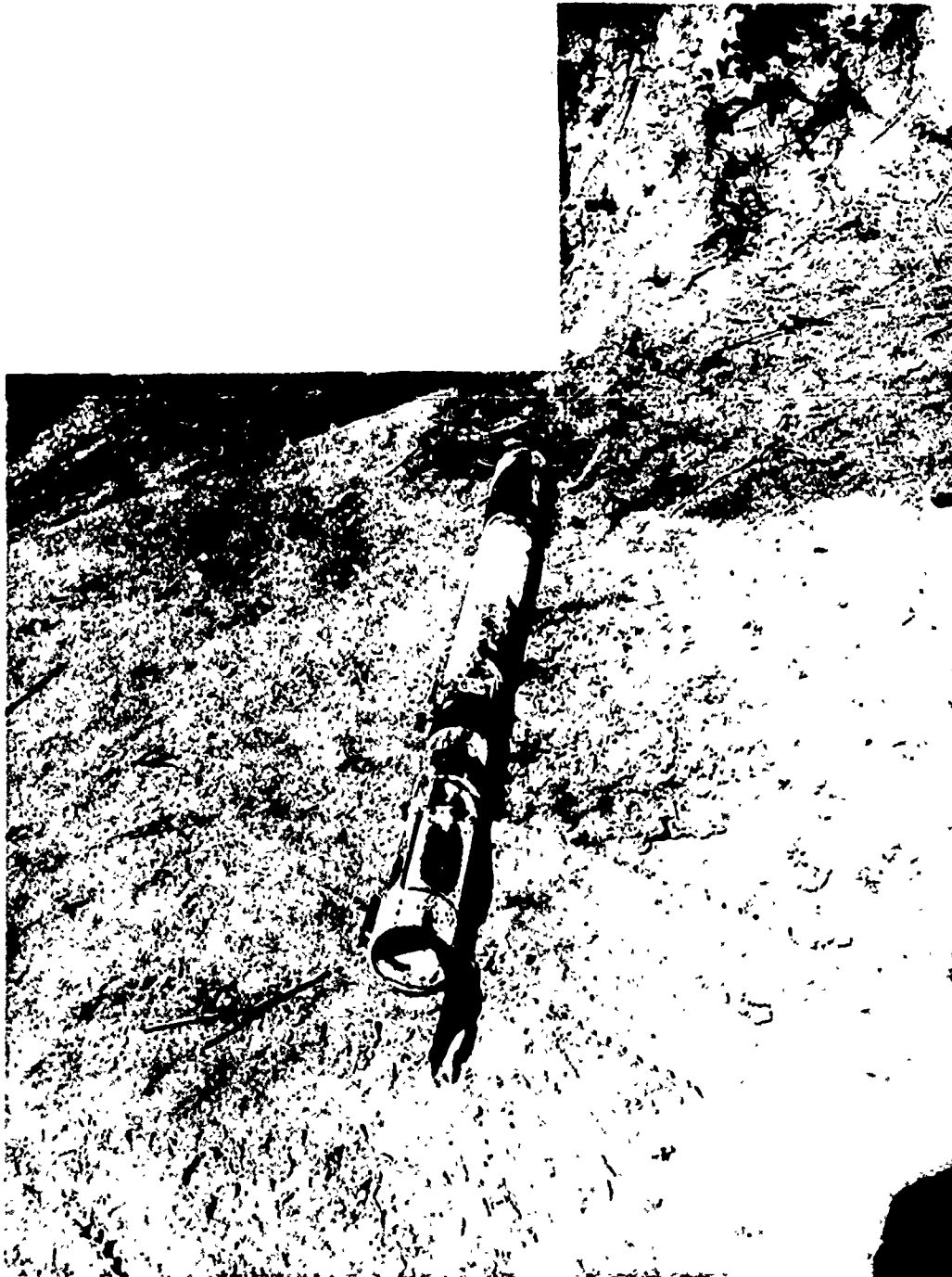

PHD-0805-4-73

Figure 5

31 August 1972

SIDEWINDER AIM-9 Missile after exposure to fast cook-off test No. GM-1.

View: Part of the missile from which the aft section of the motor was separated by an explosive reaction.

C-3



PHD-0806-4-73

28 August 1972

Figure 6

SIDEWINDER AIM-9 Missile after fast cook-off test No. GM-1.

View: Indentation on the retainer stand caused by the missile being forced forward by motor re-
action.

C-4



PHD-0807-4-73

Figure 7

31 August 1972

MARK 48 MOD 4 SIDEWINDER warhead after deflagration in fast cook-off test No. GM-1.

View: Bulge in warhead case.

SIDEWINDER MISSILE FAST COOK-OFF

Test No. GM-2

Data Sheet

Item Tested: SIDEWINDER AIM-9 Missile

Components: MARK 48 MOD 4 - Warhead containing 6 pounds of PBXN-3 explosive
MARK 13 MOD 0 - Safe and Arm Device
MARK 36 MOD 0 - Rocket Motor
MARK 264 MOD 0 - Motor Igniter
Simulated - Guidance and Control Sections

Date of Test: 8 September 1972

Weather Conditions: Cloudy, 6 knot wind, temperature 78°F

Facility: 30' x 30' retainer cage with encaged fuel pit and test stand

Fuel: 200 gallons of JP-5

Test Fire: Flame temperature exceeded 1000°F at 19 seconds after start of fire and averaged 1720°F during the test.

Flame Duration: Seven minutes

Results: The rocket motor deflagrated at 59 seconds into the test. The force of the reaction threw the warhead and the safe and arm device into the fuel pit. These items did not react. Figure 8 shows the forward section of the motor that remained in the test stand.

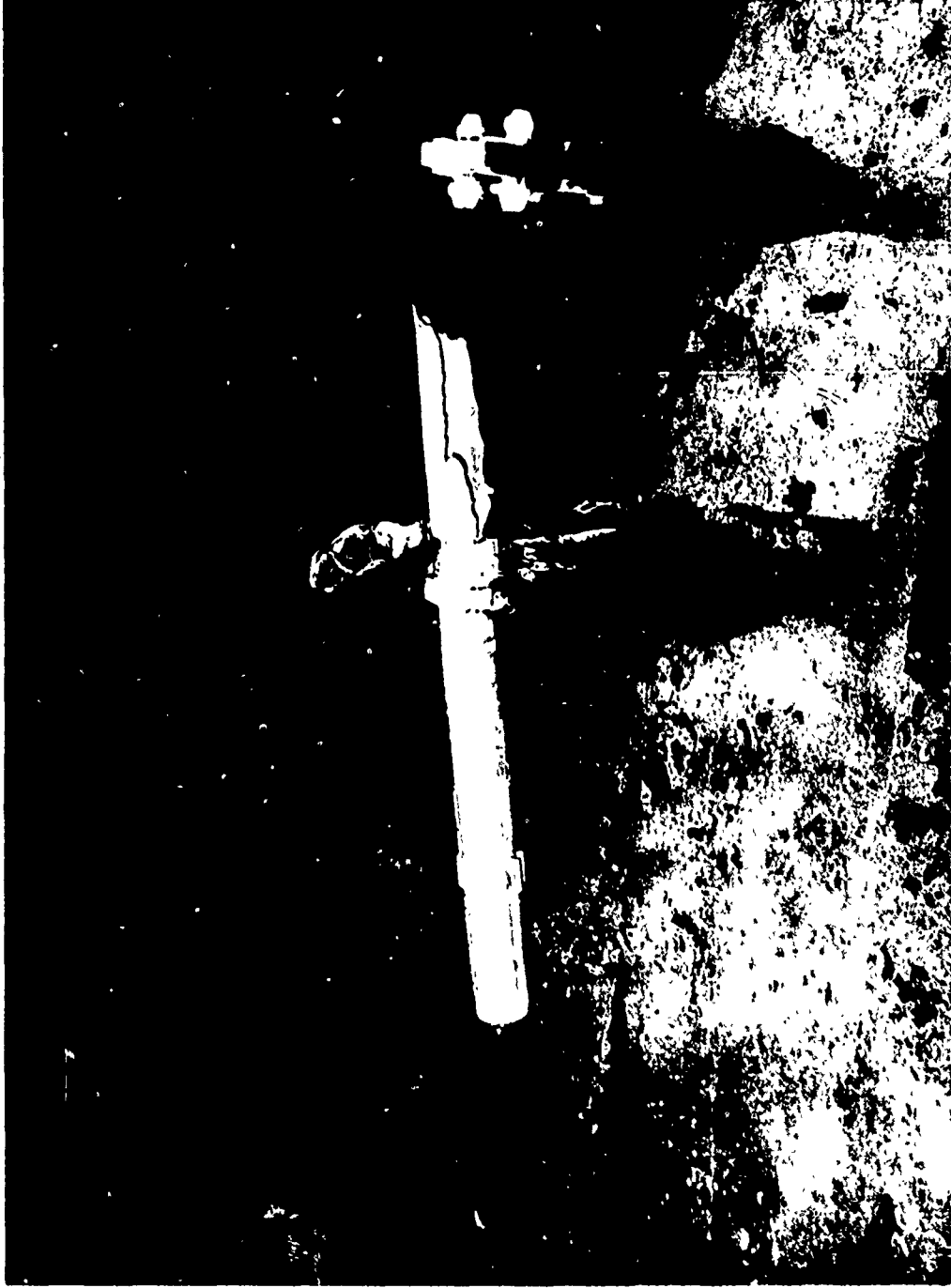

PHD-0808-4-73

Figure 8

12 September 1972

Section of SIDEWINDER AIM-9 Missile after fast cook-off test No. GM-2.

C-7

WALLEYE GUIDED WEAPON FAST COOK-OFF

Test No. GM-3

Data Sheet

Item Tested: WALLEYE Guided Weapon MARK 1 MOD 0

Components: MARK 58 MOD 0 - Warhead containing 416 pounds of Comp-B explosive
MARK 44 MOD 0 - Booster
MARK 328 MOD 0 - Fuze
EX 5 MOD 0 - Control Unit
MARK 27 MOD 0 - Guidance Unit with Nose Cover

Date of Test: 27 October 1972

Weather Conditions: Clear, 6-8 knots wind, temperature 55°F

Facility: 30' x 30' open pit with test stand, Figure 9

Fuel: 1000 gallons of JP-5

Test Fire: Flame temperature exceeded 1000°F at 47 seconds after start of fire and averaged 1720°F for the duration of the test.

Flame Duration: 11 minutes

Results: The warhead reacted by deflagrating at three minutes 30 seconds into the test. The reaction ruptured the rear of the warhead. A partial detonation occurred at two minutes 49 seconds after the initial reaction. The secondary reaction was of such severity that burning explosive was thrown about the test site to a radius of 1200 feet. A number of grass fires were started by the burning explosive. Neither the booster, fuze nor any fragment samples were recovered.



PHD-0809-4-73

Figure 9

3 November 1972

WALLEYE Guided Weapon MARK 1 MOD 0 pre-test configuration.

WALLEYE GUIDED WEAPON FAST COOK-OFF

Test No. GM-4

Data Sheet

Item Tested: WALLEYE Guided Weapon MARK 1 MOD 0

Components: MARK 58 MOD 0 - Warhead containing 416 pounds
of Comp-B explosive
MARK 44 MOD 0 - Booster
MARK 328 MOD 0 - Fuze
EX 5 MOD 0 - Control Unit
MARK 27 MOD 0 - Guidance Unit without nose cover

Date of Test: 3 November 1972

Weather Conditions: Clear, 8-10 knots, temperature 80°F

Facility: 30' x 30' open pit with test stand

Fuel: 1000 gallons of JP-5

Test Fire: Flame temperature at the weapon exceeded 1000°F
at 36 seconds after start of test and averaged
1700°F during the test.

Flame Duration: 10 minutes

Results: At two minutes 57 seconds after the fire was
ignited, the warhead deflagrated. Burning
occurred for three minutes 33 seconds, causing
the booster to deflagrate mildly. Figure 10
shows some unburned Comp-B explosive and the
rupture in the warhead case caused by the initial
reaction.



PHD-0810-4-73

Figure 10

9 November 1972

Rupture in the MARK 58 MOD 0 WALLEYE case caused by a deflagration in fast cook-off test No. GM-4.

C-11

SPARROW III MISSILE FAST COOK-OFF

Test No. GM-5

Data Sheet

Item Tested: SPARROW III AIM-7 Missile

Components: MARK 38 MOD 0 - Warhead containing 20 pounds of PBXN-101 explosive
MARK 35 MOD 0 - Safe and Arm Device
MARK 38 MOD 0 - Booster
MARK 38 MOD 0 - Rocket Motor containing MARK 95 MOD-0 propellant
MARK 265 MOD 0 - Motor Igniter
Ballast loaded Guidance and Control Sections

Date of Test: 11 December 1972

Weather Conditions: Partly cloudy, 2 knot wind, temperature 55°F

Facility: 30' x 30' retainer cage with encaged fuel pit and test stand, Figure 11

Fuel: 200 gallons of JP-5

Test Fire: Flame temperature at the missile exceeded 1000°F at 29 seconds after the start of the test and averaged 1800°F during the test.

Flame Duration: Nine minutes 30 seconds

Results: At two minutes 3 seconds after fire ignition, the motor started to burn violently. The warhead reacted by burning at 16 minutes three seconds into the test. At four minutes 51 seconds after the warhead began burning, the safe and arm device deflagrated mildly. At one minute 13 seconds after the safe and arm device reacted, the booster deflagrated. Figures 11-13 show the pre-test configuration and post-test views of the weapon remains.

Thermocouple locations are shown in Figure 14 and the time-temperature data are presented in Figure 15.

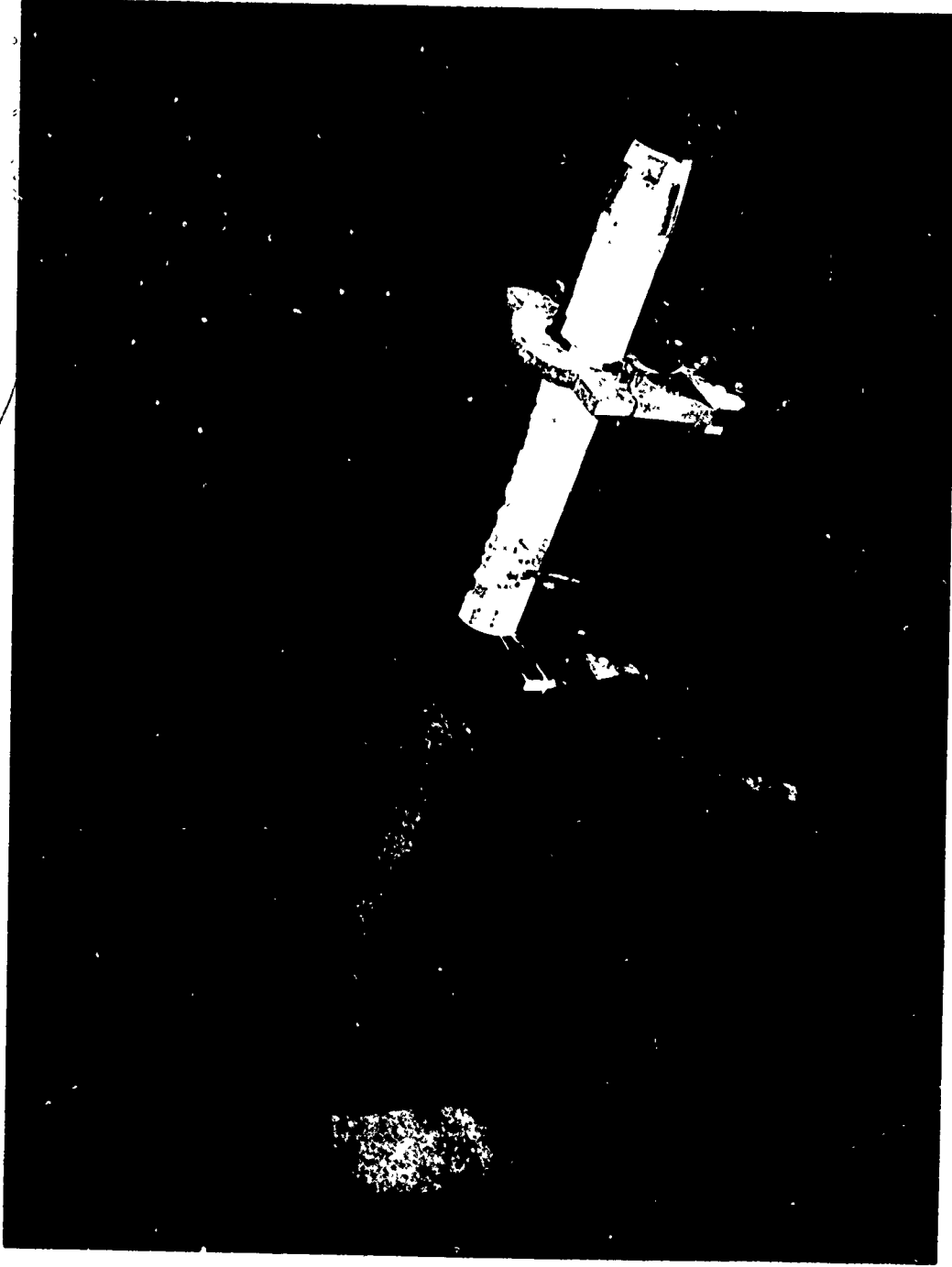

PHD-0811-4-73

Figure 11

12 December 1972

SPARROW III AIM-7 Missile pre-test configuration.

C-13



PHD-0812-4-73

Figure 12

12 December 1972

Remains of the SPARROW III AIM-7 Missile after reacting in fast cook-off test. No. GM-5.

C-14

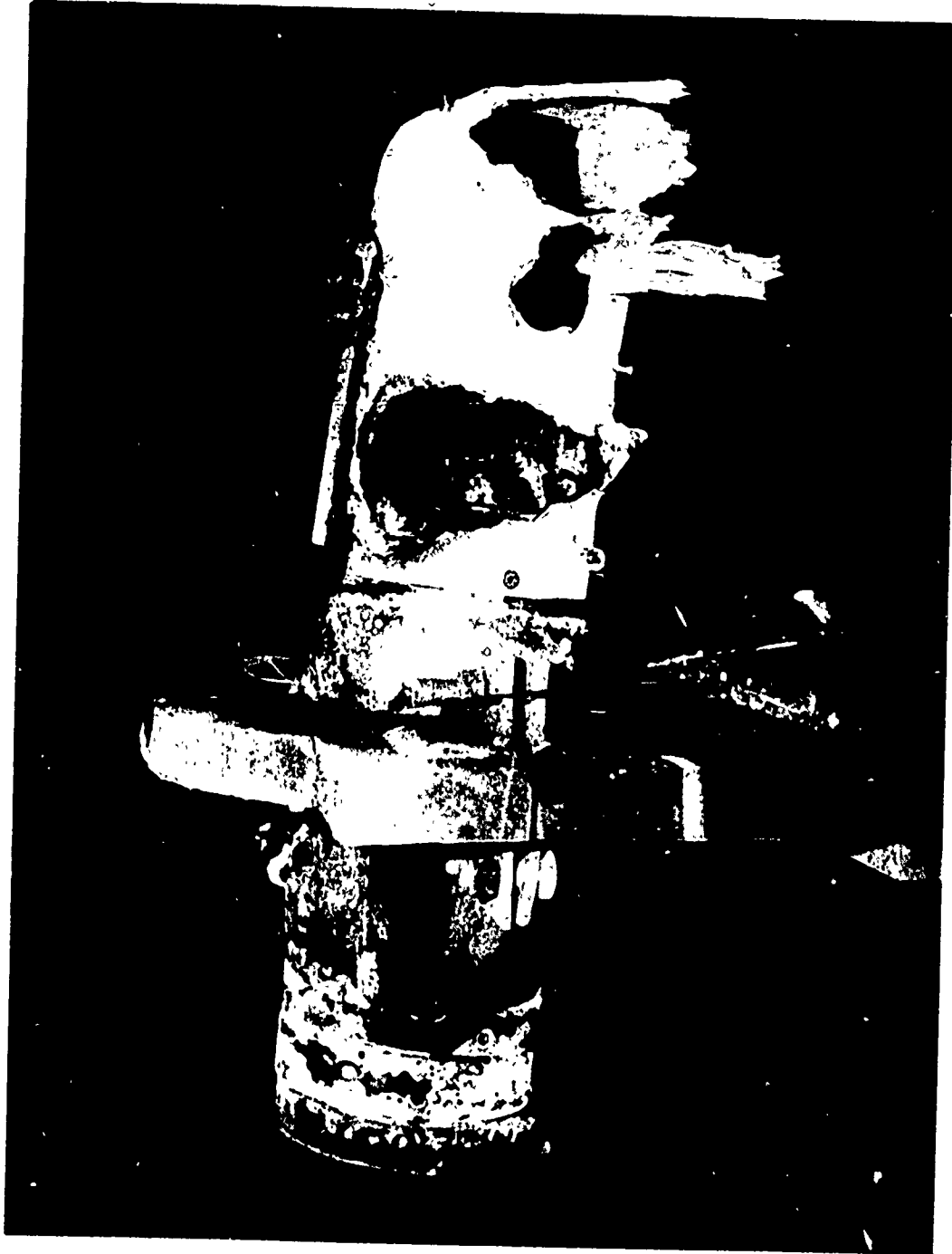

PHD-0813-4-73

Remains of SPARROW III AIM-7 warhead and motor after both deflagrated in fast cook-off test
No. GM-5.

Figure 13

12 December 1972

C-15

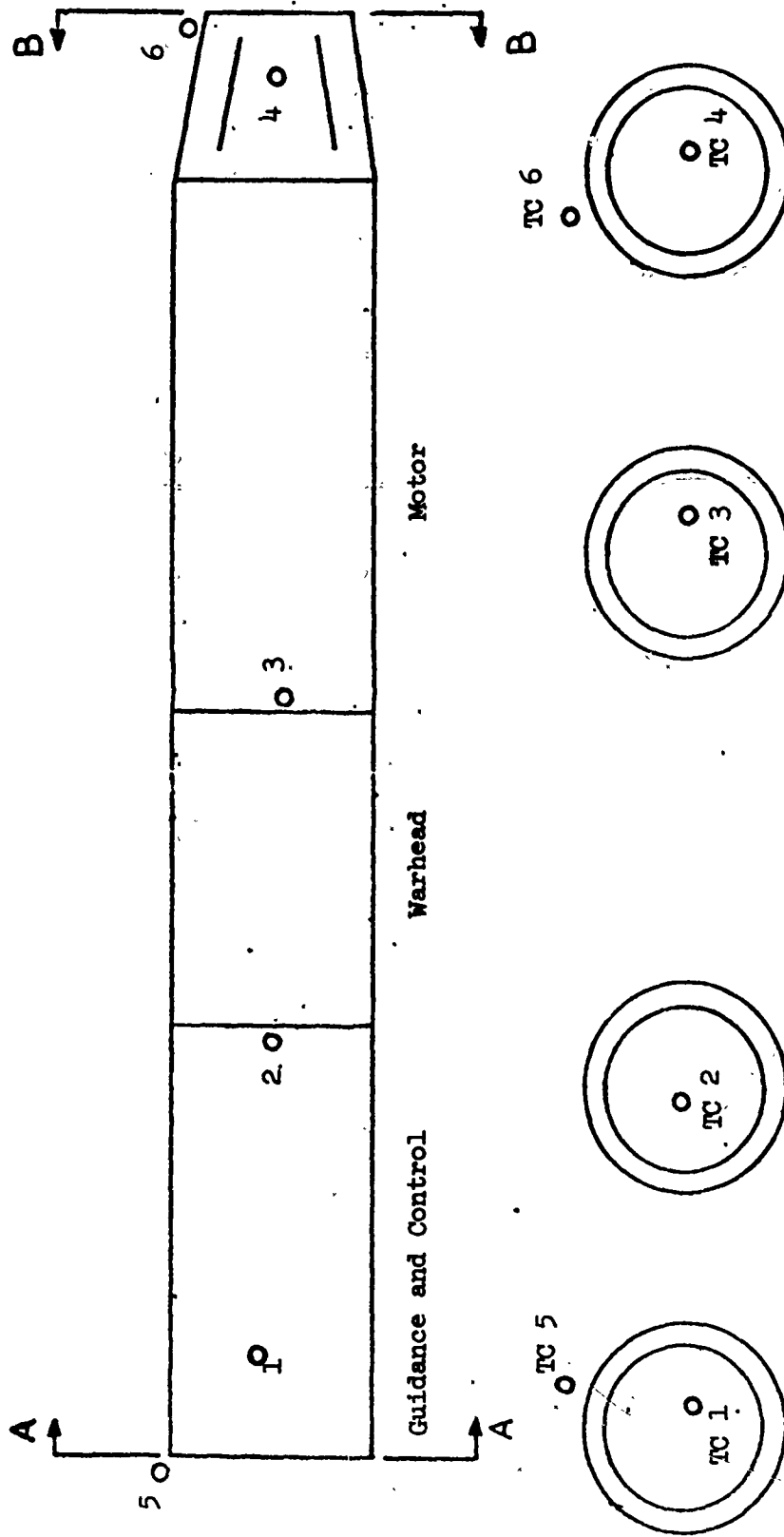

Section AA

Section BB

Figure 14

Location of thermocouples in the SPARROW III AIM-7 Missile for fast cook-off test

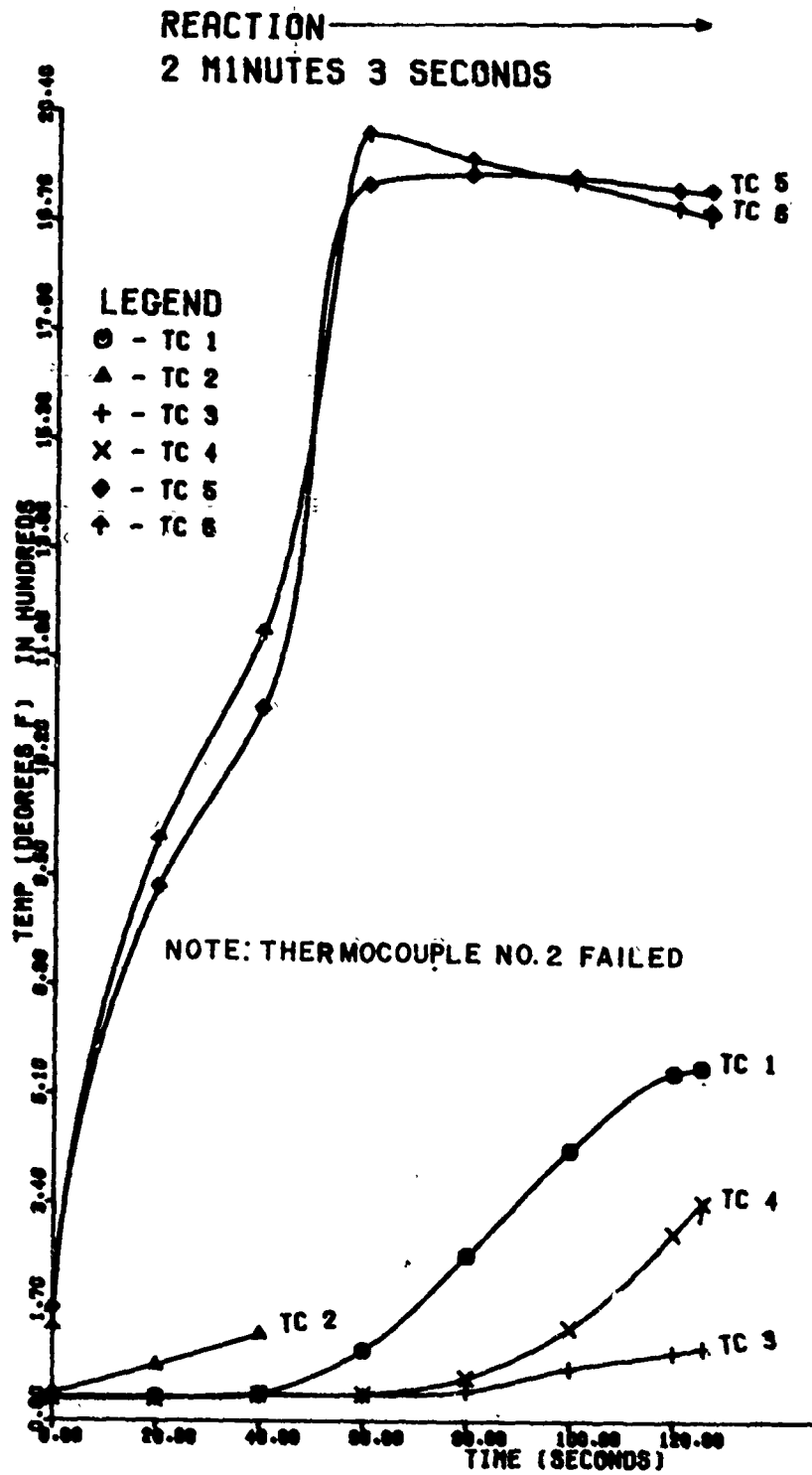

FIGURE 15
TIME-TEMPERATURE DATA FOR FAST COOK-OFF TEST NO. GM-5 OF
THE SPARROW III AIM-7 MISSILE SYSTEM

SPARROW III MISSILE FAST COOK-OFF

Test No. GM-6

Date Sheet

Item Tested: SPARROW AIM-7 Missile

Components: MARK 38 MOD 0 - Warhead containing 20 pounds
of PBXN-101 explosive
MARK 35 MOD 0 - Safe and Arm Device
MARK 38 MOD 0 - Booster
MARK 28 MOD 0 - Rocket Motor containing MARK 75
MOD 0 - Propellant
MARK 265 MOD 0 - Motor Igniter
Ballast loaded Guidance and Control Sections

Date of Test: 12 December 1972

Weather Conditions: Cloudy, 6-9 knots wind, temperature 58°F

Facility: 30' x 30' retainer cage with encaged test pit
and test stand

Fuel: 200 gallons of JP-5

Test Fire: Flame buildup was rapid, engulfing the missile
at 17 second after start of fire

Flame Duration: 10 minutes

Results: The rocket motor deflagrated at one minute 31
seconds after start of fire. At fourteen minutes
10 seconds after the initial reaction, the war-
head detonated. Figure 16 shows a sample of
the fragments and pieces of the motor recovered
after the test.



PHD-0814-4-73

Figure 16

14 December 1972

Sample of the motor and warhead fragments of the SPARROW III AIM-7 Missile after the warhead detonated in fast cook-off test No. CM-6.

SHRIKE MISSILE FAST COOK-OFF

Test No. GM-7

Data Sheet

Item Tested: SHRIKE AGM-45A Missile

Components: MARK 68 MOD 0 - Warhead Containing 50 pounds of
PBXN-101 explosive
MARK 330 MOD 0 - Fuze
MARK 44 MOD 0 - Booster
MARK 39 MOD 3 - Rocket Motor containing MARK 76
MOD 2 propellant
MARK 265 MOD 0 - Motor Igniter
Simulated - Guidance Unit

Date of Test: 13 December 1972

Weather Conditions: Cloudy, 10 knot wind, temperature 52°F

Facility: 30' x 30' retainer cage with encaged fuel pit
and test stand

Fuel: 200 gallons of JP-5

Test Fire: Flame temperature at the missile exceeded 1000°F
at 23 seconds after start of the fire and averaged
1755°F during the test.

Flame Duration: Seven minutes 40 seconds

Results: At one minute 44 seconds after fire ignition,
the rocket motor deflagrated. The warhead
exploded at 13 seconds after the motor reacted,
throwing fragments and burning explosive
about the cage. Figure 17 shows the pre-test
configuration. Figures 18 and 19 show the
motor and warhead remains. Thermocouple
locations are shown in Figure 20 and the time-
temperature data are provided in Figure 21.

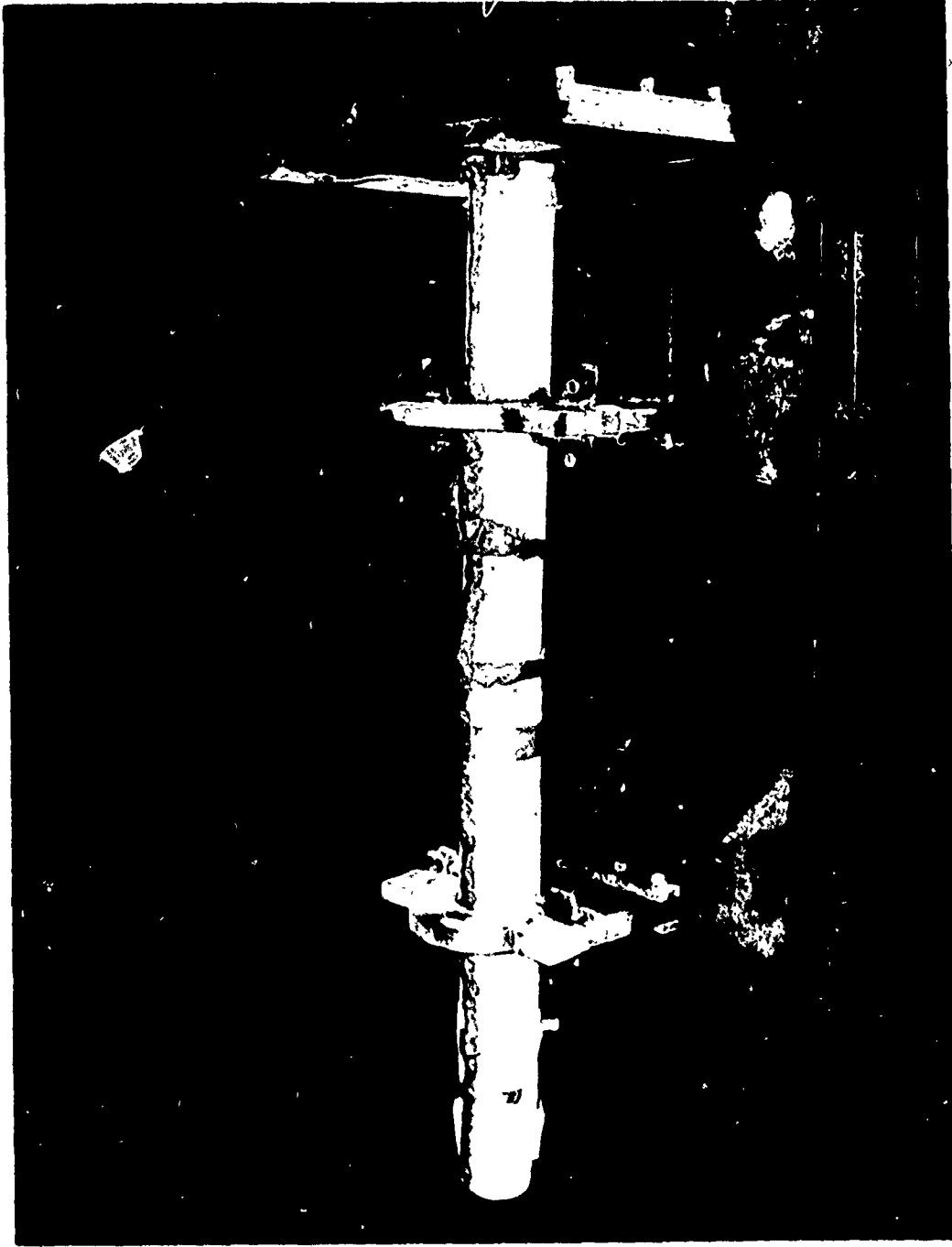

PHD-0814-4-73

Figure 17

SHRIKE AGM-45A Missile pre-test configuration.

14 December 1972

C-21



PHD-0816-4-73

Figure 18

14 December 1972

Pieces of the SHRIKE AGM-45A Missile motor after deflagrating in fast cook-off test No. GM-7.

C-22



PHD-0817-4-73

Figure 19

14 December 1972

Fragments from SHRIKE AGM-45A Missile warhead and simulated guidance unit after exploding in fast cook-off test No. GM-7.

C-23

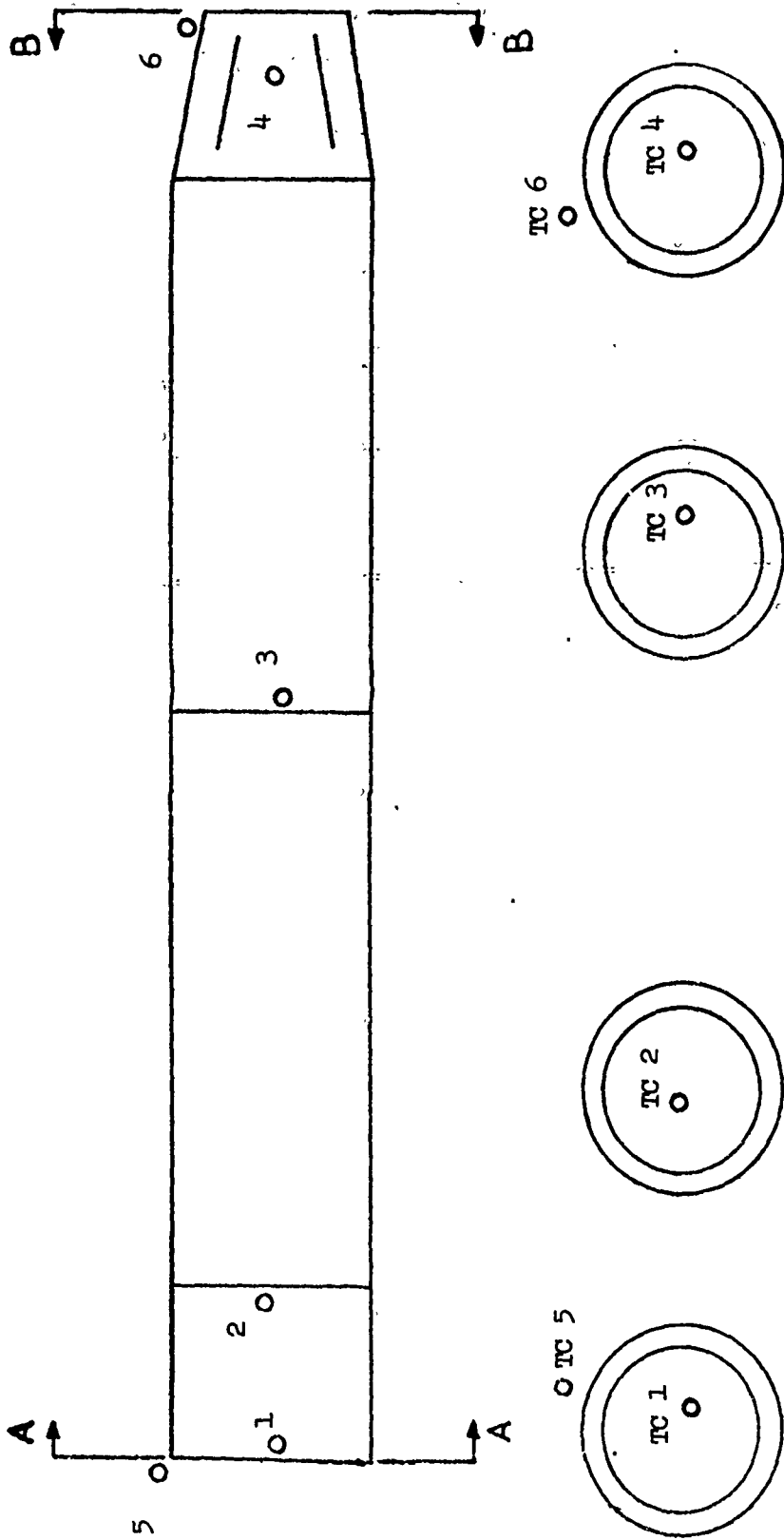

Section BB

Figure 20

Section AA

Thermocouple location in the SHRIKE ACM-45A Missile for fast cook-off test. No. GM-7

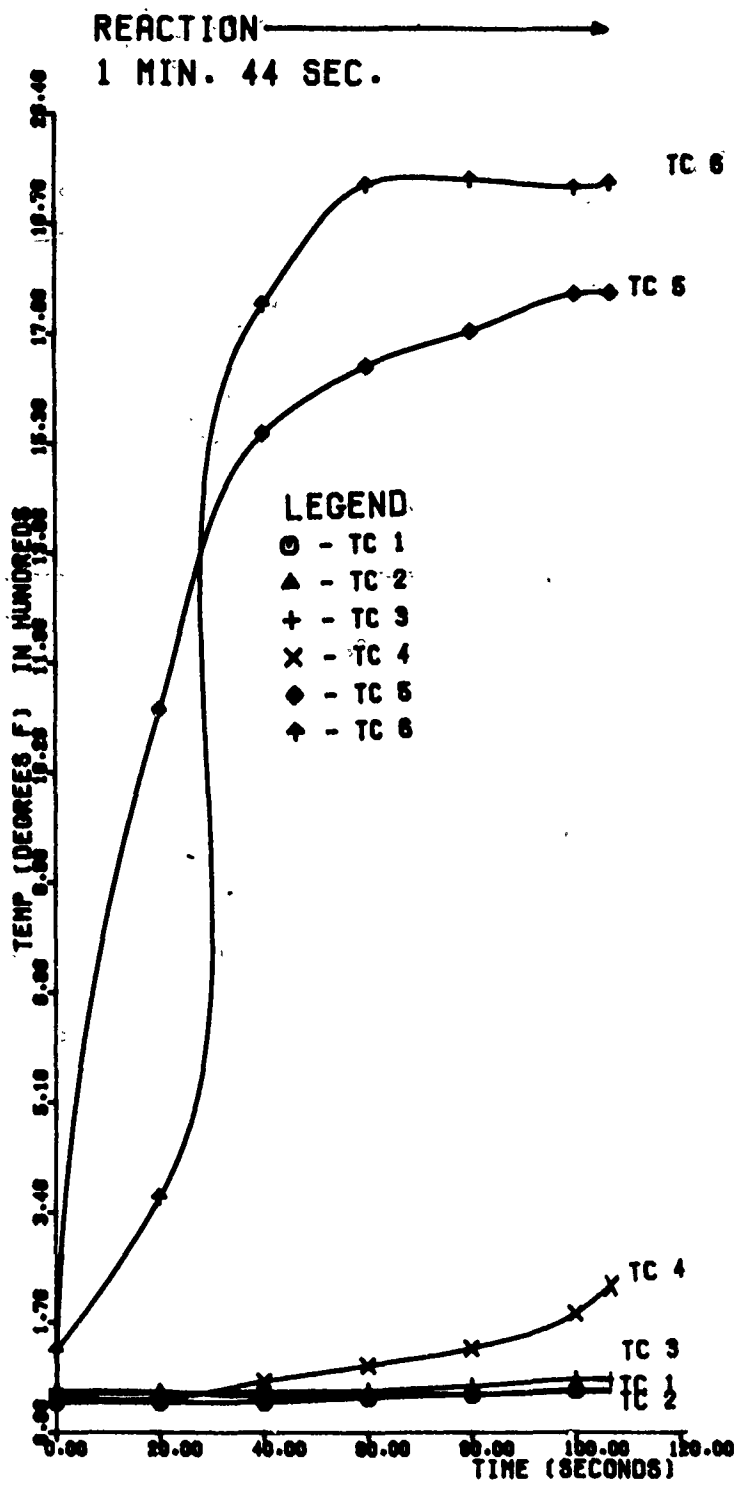

FIGURE 21
 TIME-TEMPERATURE DATA FOR FAST COOK-OFF TEST NO. GM-7 OF
 THE SHRIKE AGM-45A MISSILE SYSTEM

SHRIKE MISSILE FAST COOK-OFF

Test No. GM-8

Data Sheet

Item Tested: SHRIKE AGM-45A Missile

Components: MARK 68 MOD 0 - Warhead containing 50 pounds of PBXN-101 explosive
MARK 330 MOD 0 - Fuze
MARK 44 MOD 0 - Booster
MARK 39 MOD 3 Rocket Motor containing MARK 76 MOD 2 - Propellant
MARK 265 MOD 0 - Motor Igniter
Simulated - Guidance Unit

Date of Test: 14 December 1972

Weather Conditions: Cloudy, 3 knot wind, temperature 53°F

Facility: 30' x 30' retainer cage with encaged fuel pit and test stand

Fuel: 150 gallons of JP-5

Test Fire: Flame temperature exceeded 1000°F at 16 seconds after start of fire and averaged 1860°F during the test.

Flame Duration: Five minutes

Results: The warhead exploded at one minute 17 seconds after the fire was started. The motor deflagrated at one minute 29 seconds. Fragments from the warhead were thrown about the test site. Figure 22 shows the warhead fragments that were recovered from the test. The remains from the motor are shown in Figure 23. Thermocouple locations and the time-temperature data are provided in Figures 24 and 25.



PHD-0818-4-73

Figure 22

16 January 1973

Fragments of the SHRIKE AGM-45A Missile warhead after it exploded during fast cook-off test No. GM-8.

C-27



PHD-0819-4-73

Figure 23

16 January 1973

Remains of the SHRIKE AGM-45A Missile motor after fast cook-off test No. GM-8.

C-28

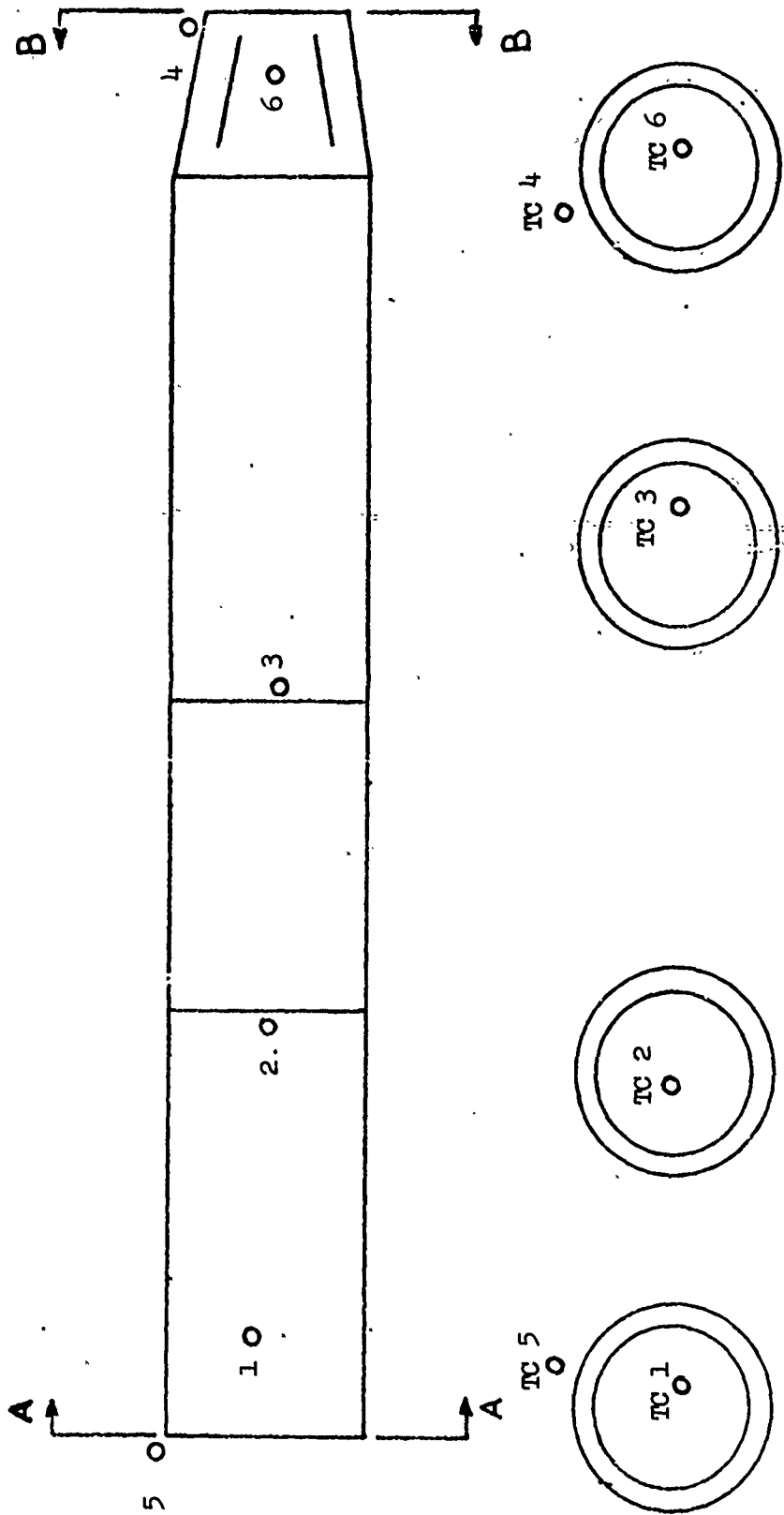

Figure 24

Location of thermocouples in the SHRIKE AGM-45 Missile for fast cook-off test No. GM-8

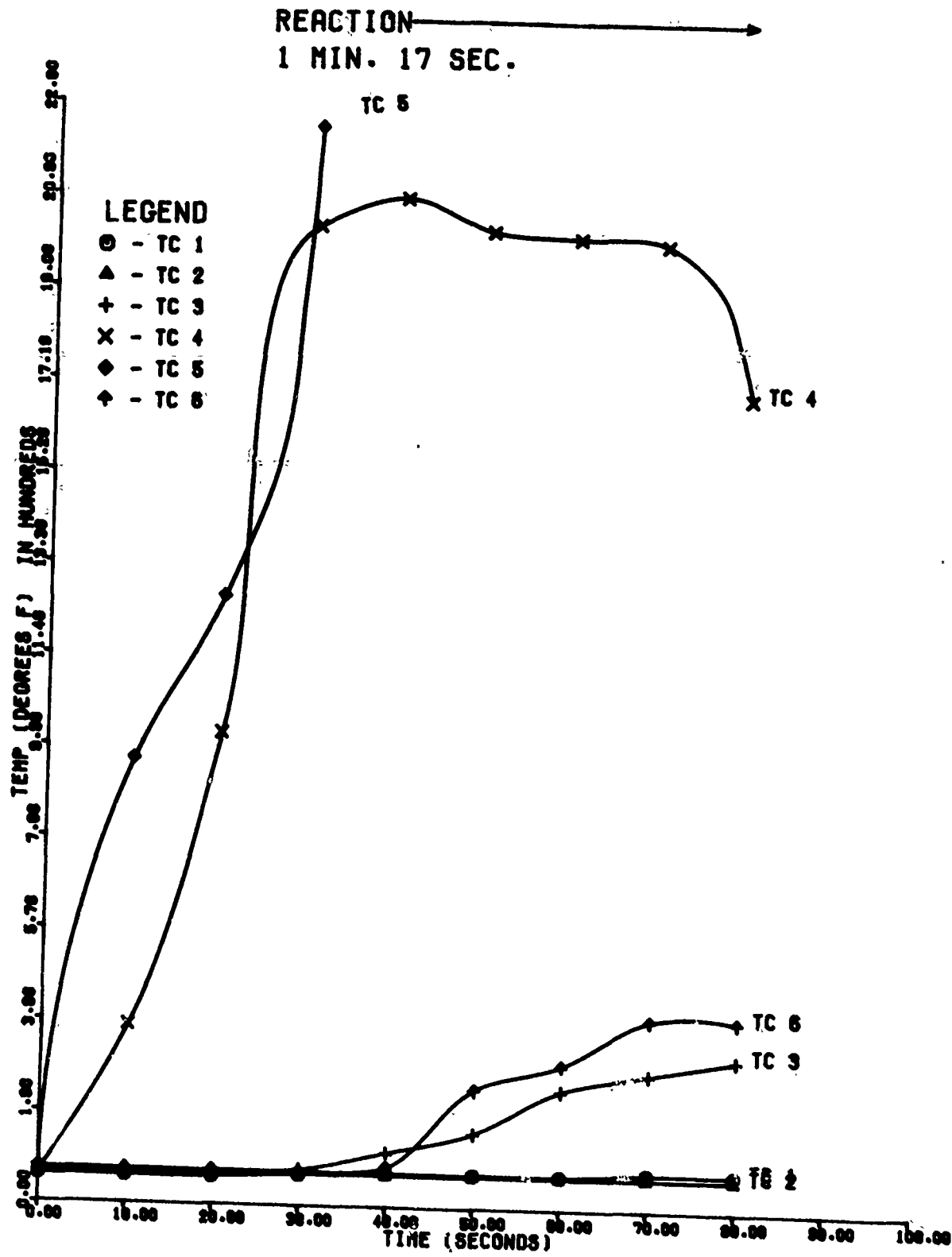

FIGURE 25
TIME-TEMPERATURE DATA FOR FAST COOK-OFF TEST NO. GM-8 OF
THE SHRIKE AGM-45A MISSILE SYSTEM

APPENDIX D

DISTRIBUTION

Commander
Naval Ordnance System Command
Washington, D. C. 20361
Attn: ORD-00
ORD-048
ORD-9132
ORD-5535

Commander
Naval Ship Systems Command
Washington, D. C. 20361
Attn: NAVSHIPS-01G
NAVSHIPS-2052
NAVSEC -2052X

Commander
Naval Ship Engineering Center
Prince George's Center Building
Hyattsville, Maryland 20782
Attn: 6105
6110

Chief of Naval Operations
Washington, D. C. 20350
Attn: NOP-00
NOP-07
NOP-07T
NOP-01C
NOP-09B93
NOP-098
NOP-0982
NOP-56
NOP-82J
NOP-722D2

Commander
Naval Air Force
U. S. Pacific Fleet
Box 1210, Naval Air Station
San Diego, California 92135

Commander
Naval Air Force
U. S. Atlantic Fleet
Naval Air Station
Norfolk, Virginia 23511

DISTRIBUTION (CONTINUED)

Director
Naval Weapons Engineering Support Activity
Washington Navy Yard
Washington, D. C. 20390

Chief of Naval Material
Washington, D. C. 20360
Attn: NMAT-00
 NMAT-09
 NMAT-016
 NMAT-03
 NMAT-046

Commander
Naval Air Systems Command
Washington, D. C. 20361
Attn: AIR-03
 AIR-04
 AIR-4104
 AIR-534
 AIR-05
 AIR-510
 AIR-537
 AIR-52043A
 AIR-632
 AIR-532D
 AIR-5323
 AIR-532
 AIR-5324
 AIR-5366

Director
Naval Research Laboratory
Washington, D. C. 20390
Attn: Technical Library

Commander
Naval Ordnance Laboratory
Silver Spring, Maryland 20910
Attn: Technical Library

DISTRIBUTION (CONTINUED)

Commander
Naval Weapon Center
China Lake, California 93555
Attn: 453
3022
8514
4532
4561
Technical Library

Commanding Officer
Naval Ordnance Station
Indian Head, Maryland 20640
Attn: Technical Library

Commander
Naval Safety Center
Naval Air Station
Norfolk, Virginia 23511

(2)

Commanding Officer
Naval Weapons Station
Yorktown, Virginia 23491

Commanding Officer
Naval Weapons Stations
Charleston, South Carolina 29408

Commanding Officer
Naval Weapons Station
Concord, California 94520

Commanding Officer
U. S. Naval Ammunition Depot
Crane, Indiana 47522
Attn: WPEC

Commander
Naval Missile Center
Point Mugu, California 93041
Attn: 5713
4718
593-22
5710.10
Technical Library

(2)

(2)

DISTRIBUTION (CONTINUED)

Commanding Officer
Naval Weapons Evaluation Facility
Kirtland Air Force Base
Albuquerque, New Mexico 87117

Administrator
Defense Documentation Center for
Scientific and Technical Information (DDC)
Building No. 5, Cameron Station
Alexandria, Virginia 22314 (2)

Commanding Officer
Robbins Air Force Base, Georgia 31093
Attn: MMNTBA

Commanding Officer
Hill Air Force Base, Utah 84401
Attn: MMNTA (2)

Air Proving Ground Center
Eglin Air Force Base
Eglin, Florida 32542

Commanding Officer
Aberdeen Proving Ground
Aberdeen, Maryland 21005 (2)

Local:

T
TP
TPE
TPB/JAR (2)
ESE
MIP-2
MIP-3 (5)
MIM
MIL (2)

DISTRIBUTION (CONTINUED)

Commanding Officer
Naval Weapons Evaluation Facility
Kirtland Air Force Base
Albuquerque, New Mexico 87117

Administrator
Defense Documentation Center for
Scientific and Technical Information (DDC)
Building No. 5, Cameron Station
Alexandria, Virginia 22314 (2)

Commanding Officer
Robbins Air Force Base, Georgia 31093
Attn: MMNTBA

Commanding Officer
Hill Air Force Base, Utah 84401
Attn: MMNTA (2)

Air Proving Ground Center
Eglin Air Force Base
Eglin, Florida 32542

Commanding Officer
Aberdeen Proving Ground
Aberdeen, Maryland 21005 (2)

Local:

T
TP
TPE
TPB/JAR (2)
ESE
MIP-2
MIP-3 (5)
MIM
MIL (2)

UNCLASSIFIED

Security Classification

DOCUMENT CONTROL DATA - R & D

(Security classification of title, body of abstract and indexing annotation must be entered when the overall report is classified)

1. ORIGINATING ACTIVITY (Corporate author)

Naval Weapons Laboratory
Dahlgren, Virginia 22448

2a. REPORT SECURITY CLASSIFICATION

UNCLASSIFIED

2b. GROUP

3. REPORT TITLE

SURVIVABILITY OF AIR LAUNCHED GUIDED WEAPONS IN A FIRE ENVIRONMENT

4. DESCRIPTIVE NOTES (Type of report and inclusive dates)

5. AUTHOR(S) (First name, middle initial, last name)

J. A. Robinson

6. REPORT DATE

January 1973

7a. TOTAL NO. OF PAGES

7b. NO. OF REFS

8a. CONTRACT OR GRANT NO.

8b. ORIGINATOR'S REPORT NUMBER(S)

b. PROJECT NO.

NWL TR-2943

c.

9b. OTHER REPORT NO(S) (Any other numbers that may be assigned this report)

d.

10. DISTRIBUTION STATEMENT

Distribution limited to U.S. Gov't. agencies only; Test and Evaluation; January 1973. Other requests for this document must be referred to the Commander, Naval Weapons Laboratory, Dahlgren, Virginia 22448.

11. SUPPLEMENTARY NOTES

12. SPONSORING MILITARY ACTIVITY

13. ABSTRACT

Tests were conducted to establish fast cook-off characteristics of the following guided weapons: (a) SIDEWINDER (AIM-9), (b) WALLEYE (MARK 1 MOD 0), (c) SPARROW III (AIM-7), and (d) SHRIKE (AGM-45A). The type of reaction that occurred, the time to reaction and time-temperature data were obtained for each guided weapon when engulfed in fire from burning JP-5 fuel. These data are applicable to the design of thermal protection systems and the development of safer fire fighting procedures.