

UNCLASSIFIED

AD NUMBER	
AD025029	
CLASSIFICATION CHANGES	
TO:	unclassified
FROM:	confidential
LIMITATION CHANGES	
TO:	Approved for public release, distribution unlimited
FROM:	Distribution authorized to U.S. Gov't. agencies and their contractors; Administrative/Operational Use; NOV 1953. Other requests shall be referred to Naval Ordnance Weapons Laboratory, Naval Proving Ground, Dahlgren, VA.
AUTHORITY	
USNSWC notice, 7 Feb 1978; USNSWC notice, 7 Feb 1978	

THIS PAGE IS UNCLASSIFIED

Armed Services Technical Information Agency

AD

PLEASE RETURN THIS COPY TO:

ARMED SERVICES TECHNICAL INFORMATION AGENCY
DOCUMENT SERVICE CENTER
Knott Building, Dayton 2, Ohio

Because of our limited supply you are requested to return this copy as soon as it has served your purposes so that it may be made available to others for reference use. Your cooperation will be appreciated.

25029

NOTICE: WHEN GOVERNMENT OR OTHER DRAWINGS, SPECIFICATIONS OR OTHER DATA ARE USED FOR ANY PURPOSE OTHER THAN IN CONNECTION WITH A DEFINITELY RELATED GOVERNMENT PROCUREMENT OPERATION, THE U. S. GOVERNMENT THEREBY INCURS NO RESPONSIBILITY, NOR ANY OBLIGATION WHATSOEVER; AND THE FACT THAT THE GOVERNMENT MAY HAVE FORMULATED, FURNISHED, OR IN ANY WAY SUPPLIED THE SAID DRAWINGS, SPECIFICATIONS, OR OTHER DATA IS NOT TO BE REGARDED BY IMPLICATION OR OTHERWISE AS IN ANY MANNER LICENSING THE HOLDER OR ANY OTHER PERSON OR CORPORATION, OR CONVEYING ANY RIGHTS OR PERMISSION TO MANUFACTURE, USE OR SELL ANY PATENTED INVENTION THAT MAY IN ANY WAY BE RELATED THERETO.

Reproduced by
DOCUMENT SERVICE CENTER
KNOTT BUILDING, DAYTON, 2, OHIO

CONFIDENTIAL

**NOTICE: THIS DOCUMENT CONTAINS INFORMATION AFFECTING THE
NATIONAL DEFENSE OF THE UNITED STATES WITHIN THE MEANING
OF THE ESPIONAGE LAWS, TITLE 18, U.S.C., SECTIONS 793 and 794.
THE TRANSMISSION OR THE REVELATION OF ITS CONTENTS IN
ANY MANNER TO AN UNAUTHORIZED PERSON IS PROHIBITED BY LAW.**

AD NO. 85429
ASTIA FILE COPY

U. S. NAVAL PROVING GROUND
DAHLGREN, VIRGINIA

REPORT NO. 1205

SURFACE TARGET PROJECTILE FUZES;
RESEARCH, DEVELOPMENT AND TESTS OF

24th Partial Report

MARK 48 AND MARK 28 PROJECTILE FUZES;
BALLISTIC TEST OF

FINAL Report

Task

Assignment NPG-Re2b-3-1-53

Copy No. 10

Classification CONFIDENTIAL
SECURITY INFORMATION

DISCLAIMER NOTICE

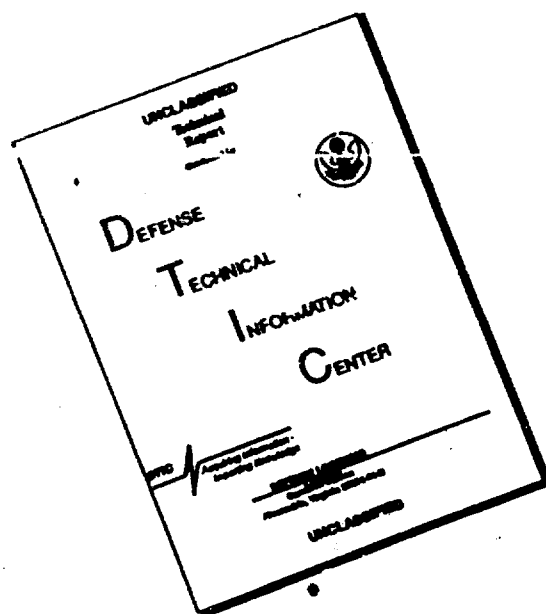

THIS DOCUMENT IS BEST QUALITY AVAILABLE. THE COPY FURNISHED TO DTIC CONTAINED A SIGNIFICANT NUMBER OF PAGES WHICH DO NOT REPRODUCE LEGIBLY.

Mark 48 and Mark 28 Projectile Fuzes; Ballistic Tests of

PART A

SYNOPSIS

1. This test was conducted in an attempt to demonstrate that:
(1) premature fuze action could be induced in Mark 28 and Mark 48 fuzes modified to permit gas flow, (2) premature fuze action could not be induced in similarly modified fuzes with "O" ring seals and (3) Mark 28 and Mark 48 fuzes with solid base plugs and "O" rings would not function prematurely.
2. It is concluded that the Mark 28 and Mark 48 fuzes can be induced to fire prematurely by permitting gas to leak through the tracer cavity and enter the auxiliary plunger chamber. None of the fuzes containing "O" ring seals, including those fuzes modified to permit gas flow, detonated prematurely.
3. None of the limited number (50 rds.) of Mark 28 and Mark 48 fuzes with cut-off flanges, solid base plugs and "O" rings prematured in flight, and, from the general engineering aspect, this design appears to be less likely to premature than standard Mark 28 and Mark 48 base detonating fuzes.

Mark 48 and Mark 28 Projectile Fuzes; Ballistic Tests of

TABLE OF CONTENTS

	<u>Page</u>
SYNOPSIS	1
TABLE OF CONTENTS.	2
AUTHORITY.	3
REFERENCES	3
BACKGROUND	3
OBJECT OF TEST	4
PERIOD OF TEST	4
REPRESENTATIVES PRESENT.	4
DESCRIPTION OF ITEM UNDER TEST	4
DESCRIPTION OF TEST EQUIPMENT.	5
PROCEDURE.	5
RESULTS AND DISCUSSIONS.	6
CONCLUSIONS.	8
APPENDIX A - NPG PHOTOGRAPHS	FIGURES 1-9 (Incl)
APPENDIX B - FUZE MODIFICATION CHART	TABLE I 1-4 (Incl)
APPENDIX C - FIRING RECORD	TABLE II 1-7 (Incl)
APPENDIX D - DISTRIBUTION.	1-2 (Incl)

Mark 48 and Mark 28 Projectile Fuzes; Ballistic Tests of

PART B

INTRODUCTION

1. AUTHORITY:

This test was authorized by reference (a) under Task Assignment NPG-Re2b-3-1-53 and conducted in general accordance with references (b) through (k).

2. REFERENCES:

- a. BUORD Conf ltr NP9 Re2b-DBLaP:bjn Ser 41887 of 10 July 1952
- b. NOL Conf ltr NP/NOL/X1-1(2885) Ser 01592 of 22 July 1952
- c. NOL Conf ltr NP/NOL/X1-1(3678) Ser 02480 FA:JSB:br of 13 November 1952
- d. NOL Conf ltr NP/NOL/X1-1(3911) Ser 02728 FA:JSB:br of 12 December 1952
- e. NOL Conf Work Request FA-37 of 21 August 1952
- f. NOL Conf Work Request FA-56 of 6 January 1953
- g. NOL Conf Work Request FA-57 of 14 January 1953
- h. NOL Conf Work Request FA-58 of 3 February 1953
- i. NOL Conf Work Request FA-68 of 18 February 1953
- j. NOL Conf Work Request FA-71 of 4 March 1953
- k. NOL Conf Work Request FA-79 of 24 April 1953

3. BACKGROUND:

a. Premature detonations have occurred in the fleet with 5", 8", and 16" projectiles, fuzed with Mark 48 and Mark 28 base detonating fuzes. Naval Ordnance Laboratory tests indicated that the prematures may have been caused by the passage of chamber gases past the fuze tracer cavity plug and retainer into the auxiliary plunger chamber of the fuze. The pressure of these trapped gases, upon fuze arming, would force the detonator plunger onto the firing pin and thus produce premature fuze action.

b. A method of sealing the fuze against gas entry, shown in Figure 1, has been devised by the Naval Ordnance Laboratory. This method utilizes an "O" ring placed around the modified tracer cavity plug at the bottom of the tracer cavity. All laboratory tests indicated that this "O" ring provided a satisfactory seal against chamber gases.

Mark 48 and Mark 28 Projectile Fuzes; Ballistic Tests of

4. OBJECT OF TEST:

This test was conducted in an attempt to demonstrate that:
 (1) premature fuze action could be induced in Mark 28 and Mark 48 fuzes modified to permit gas flow, (2) premature fuze action could not be induced to similarly modified fuzes with "O" ring seals and (3) Mark 28 and Mark 48 fuzes with solid base plugs and "O" rings would not function prematurely.

5. PERIOD OF TEST:

a. Date Project Letter	22 July 1952
b. Date Commenced Test	17 September 1952
c. Date Completed Test	14 May 1953

6. REPRESENTATIVES PRESENT:

The following representatives witnessed various phases of this test:

Mr. J. S. Bartos	Naval Ordnance Laboratory
Mr. S. Globe	Naval Ordnance Laboratory
Mr. A. A. Burgess	Naval Ordnance Laboratory
Mr. A. P. Johnson	Naval Ordnance Laboratory
Mr. J. A. Templeton	Naval Ordnance Laboratory
Mr. H. E. Evans	Naval Ordnance Laboratory

PART CDETAILS OF TEST

7. DESCRIPTION OF ITEM UNDER TEST:

a. Mark 28 and Mark 48 Base Detonating Fuzes - The fuzes of Phases I through IV were modified as indicated in Table I, Appendix (B), and in Figure 2. Table I also lists the modifications of the Phase V fuzes as shown in Figure 3. The fuzes tested in Phases VI and VII were modified as shown in Figure 4. The Phase VI and VII modifications consisted of removing the flange from the body and screwing a solid base plug into the tracer cavity. In addition an "O" ring was placed around the tracer cavity plug at the bottom of the tracer cavity to insure a gas seal if leakage occurred around the base plug.

b. The fuzes of Phases II through V contained a 33 millisecond delay placed in the explosive train to insure bore safety.

Mark 48 and Mark 28 Projectile Fuzes; Ballistic Tests of

8. DESCRIPTION OF TEST EQUIPMENT:

- a. Guns:
- (1) 8"/35 Mark A Mod 1 No. 560L ESR 223-224
 - (2) 8"/55 Mark 15 Mod 2 No. 737 ESR 48-50
 - (3) 8"/55 Mark 15 Mod 0 No. 838 ESR 245-
 - (4) 5"/38 Mark 12 Mod 1 No. 5015 ESR 1102-
 - (5) 5"/38 Mark 12 Mod 1 No. 11249 ESR 1013-1014
- b. Projectiles:
- (1) 8" HC Mark 25 Mod 2 modified for Smoke Puff Test as shown in Figure 5.
 - (2) 8" HC Mark 25 Mod 2 token loaded with 1.32±.07 lbs of explosive "D" and epsom salts as shown in Figure 6.
 - (3) 5"/38 Common Mark 46 Mod 1 explosive "D" loaded to service weight by NAD McAlester in 1945.
- c. Wads:
- In lieu of the standard cork and paper wads, pyrolin wads were used to retain the propellant charge in the cartridge case. Pyrolin burns readily and was therefore considered less likely to block the flow of gas into the fuze.
- d. Targets:
- 1" STS, 3/4" STS, 1/2" STS and sand at 0° obliquity and approximately 500 ft. range.

9. PROCEDURE:

The modified fuzes were assembled to the test projectiles and fired at proof, service, and reduced pressures against targets or down river. Cameras and observers were stationed at advantageous positions in order to observe and designate the point of premature fuze action as well as the point of normal fuze functioning, whichever occurred.

Mark 48 and Mark 28 Projectile Fuzes; Ballistic Tests of

10. RESULTS AND DISCUSSIONS:

a. The detailed results are shown in Appendix (C).

b. In Phase I, modified fuzes assembled to 8" Mk 25 Mod 2 projectiles modified for smoke puff were fired vs armor from 8"/35 and 8"/55 guns at 1830 f/s and 2775 f/s respectively. No fuze action was noted prior to or after target impact. It was believed that the smoke puff type test was not conclusive as fuze action (denoted by smoke puff action) may have occurred near the muzzle and have been obscured by the muzzle flash. Therefore, succeeding tests were conducted with token loaded 8" Mk 25 Mod 2 projectiles and fully loaded 5"/38 Mk 46 Mod 1 Common projectiles.

c. Phase II was conducted with modified Mk 28 BD fuzes assembled to 5"/38 Mk 46 Mod 1 projectiles. Rounds 1 through 12 were fired down river at reduced and service velocities and no premature fuze action was observed. In order to make certain that the fuze action had not been impaired by the modifications, round 13 was fired vs a 1/2" STS target and functioned satisfactorily approximately 30 feet behind the target. Rounds 14, 15 and 16 (fuze Nos. 16, 17 and 18) were then fired at service velocity down river and premature fuze action occurred approximately 100 feet from the muzzle. The modifications to fuze Nos. 16, 17 and 18 consisted of: (1) a 0.040 hole in the retainer, (2) a doubled over lead washer, (3) tracer plug threads combed to the minimum tolerance, (4) tracer plug seating pressure of five ft. lbs. and (5) no luting on the plug or retainer threads. These modifications differed from those of the previous fuzes tested in that the tracer plug seating torque was decreased and the plug threads were combed to minimum tolerances. Rounds 17 through 20 were then fired down river and no fuze action was observed. These fuzes contained the same modifications as fuze Nos. 16 through 18 except the hole through the retainer was 0.098 and 0.125 in diameter and an "O" ring was inserted around the bottom of the tracer plug.

d. Prior to conducting the tests of Phases III and V with token loaded 8" Mk 25 Mod 2 projectiles, static tests were conducted to determine the fragmentation characteristics of these projectiles. The beam spray (60°-120°), nose (0°) and base (180°) fragments are shown in Figures 7 and 8. From the results of these tests no exceptional personnel hazard or material damage was anticipated.

Mark 48 and Mark 28 Projectile Fuzes; Ballistic Tests of

e. The Mk 48 fuzes of Phase III were modified in a manner similar to the Mk 28 fuzes of Phase II. These fuzes were assembled to 8" Mk 25 token loaded projectiles and fired at reduced and service velocities versus 3/4" STS armor at 0° obliquity. Rounds 1 through 6 functioned high order in a conventional manner behind the target. Round 7 (fuze No. 128) prematured approximately 215 feet in front of the muzzle as shown in Figure 9. Fuze No. 128 contained modifications identical to those of Mk 28 fuze Nos. 16, 17 and 18 which prematured during the 5" tests of Phase II. Additional fuzes with identical modifications (Nos. 130 and 132) as well as other modified fuzes did not exhibit premature fuze action however. Fuze No. 136 which was modified in an identical manner to Nos. 128, 130, and 132, except for the addition of an "O" ring, did not premature and functioned in a conventional manner behind the target.

f. The Mk 28 fuzes of Phase IV were modified with more indirect routes for the gas flow. The holes through the retainers were off-center and the retainer threads were slotted through the threads parallel to the vertical axis. The fuzes were assembled to 5"/38 Mk 46 projectiles. Rounds 1 through 10 were fired down river at service velocity and no fuze action was observed. This firing indicated the possibility of detent damage during setback, by excessive gas pressure on the detonator plunger. Therefore rounds 11 and 12 were fired at service velocity versus 1/2" STS at 0° obliquity; they functioned high order approximately 45 ft. and 90 ft., respectively, behind the targets. In addition, rounds 13 and 14 were rendered inert and fired at service velocity into sand, recovered and returned to Naval Ordnance Laboratory for analysis.

g. In Phase V, modified Mk 48 fuzes were assembled to 8" Mk 25 token loaded projectiles and fired down river at service and reduced velocities. Rounds 1 through 5 were modified so that the time of gas flow past the retainer was the variable rather than the quantity of gas flow, which had been the previous variable. The ball check valve in the tracer plug was intended to open to permit gas flow into the fuze during setback and close after setback. The ball check valve in the retainer was fabricated to close during setback and open to permit gas flow past the retainer into the auxiliary plunger chamber after setback. Rounds 6 through 9 were fabricated in a manner similar to those tested prior to this phase except an effort was made to afford a less direct line of gas flow into the plunger chamber. None of the nine rounds tested exhibited premature fuze action.

Mark 48 and Mark 28 Projectile Fuzes; Ballistic Tests of

h. The Mk 28 and 48 fuzes tested during Phases VI and VII were modified as shown in Figure 4. The fuzes were assembled to 5"/38 Mk 46 and 8" HC projectiles "D" loaded to service weight and fired at proof and reduced pressures down river for water impact. None of the fifty rounds fired prematurely in flight. One 5" round and one 8" round fired at reduced velocities were duds on water impact.

PART D

CONCLUSIONS

11. a. It is concluded that the Mark 28 and Mark 48 fuzes can be induced to fire prematurely by permitting chamber gas to leak through the tracer cavity and enter the auxiliary plunger chamber. None of the fuzes containing the "O" ring seals, including those fuzes modified to permit gas flow, detonated prematurely.

b. None of the limited number (50 rds.) of Mk 28 and Mk 48 fuzes with cut-off flanges, solid base plugs and "O" rings prematurely in flight, and, from the general engineering aspect, this design appears to be less likely to premature than standard Mk 28 and 48 base detonating fuzes.

CONFIDENTIAL

NPG REPORT NO. 1205

Mark 48 and Mark 28 Projectile Fuzes; Ballistic Tests of

The tests upon which this report is based were conducted by:

R. D. CROMWELL, Plate Fuze Battery Officer
Terminal Ballistics Department

This report was prepared by:

R. D. CROMWELL, Plate Fuze Battery Officer
Terminal Ballistics Department

This report was reviewed by:

R. H. LYDDANE, Director of Research
Terminal Ballistics Department

W. B. ROBERTSON, Lieutenant Commander, USN
Terminal Ballistics Officer
Terminal Ballistics Department

C. C. BRAMBLE, Director of Research, Ordnance Group

APPROVED: J. F. BYRNE
Captain, USN
Commander, Naval Proving Ground



E. A. RUCKNER
Captain, USN
Ordnance Officer
By direction

CONFIDENTIAL
SECURITY INFORMATION

CONFIDENTIAL

NPG REPORT NO. 1205

U. S. NAVAL PROVING GROUND
DAHLGREN, VIRGINIA

Twenty-Fourth Partial Report
on
Surface Target Projectile Fuzes;
Research, Development and Tests of

Final Report
on
Mark 48 and Mark 28 Projectile Fuzes;
Ballistic Tests of

Project No.: NPG-Re2b-3-1-53
Copy No.: 10
No. of Pages: 9

Date: NOV 17 1953

CONFIDENTIAL
SECURITY INFORMATION

REVISIONS			
PN	DESCRIPTION	DATE	APPROVAL

NOTES:

1. PROCEDURE TO BE FOLLOWED IN ASSEMBLY:

- A. COAT O-RING WITH A LIGHT COATING OF SILICONE GREASE, DOW CORNING DC-3 OR DC-4 OR EQUIVALENT, AND INSERT INTO BOTTOM OF TRACER CAVITY.
- B. PLACE LEAD GASKET, DR. 453171 UNDER LIP OF PLUG, SK. 354679.
- C. COAT ALL THREADS OF PLUG WITH FUZE THREAD LUTING (UNDILUTED) MADE IN ACCORDANCE WITH NAVY DEPT. SPEC. 52 L 25 (ORD)
- D. SCREW PLUG INTO TRACER CAVITY UNTIL IT SEATS AGAINST PLUNGER RETAINER PLUG, DR 330168-3, USING A TORQUE OF 40 FT. LBS. ± 9 FT. LBS.

2. THIS ASSEMBLY DETAIL IS APPLICABLE TO PROJECTILE BASE DETONATING FUZES WHOSE DIMENSIONS ACCEPT THE TRACER MK 5 OR MK 9.

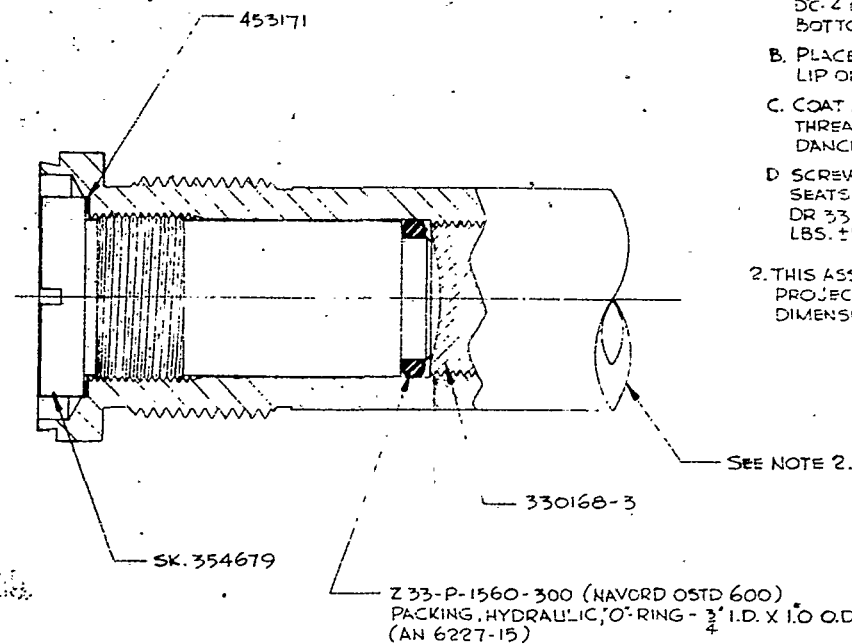

Z 33-P-1560-300 (NAVORD OSTD 600)
PACKING, HYDRAULIC, O-RING - $\frac{3}{4}$ " I.D. X 1.0 O.D.
(AN 6227-15)

SK. 354678

THIS DRAWING IS THE PROPERTY OF THE BUREAU OF ORDNANCE, DEPARTMENT OF THE NAVY. IT IS LOANED TO YOUR OFFICE AND IS NOT TO BE REPRODUCED OR TRANSMITTED IN ANY FORM OR BY ANY MEANS, ELECTRONIC OR MECHANICAL, INCLUDING PHOTOCOPYING, RECORDING, OR BY ANY INFORMATION STORAGE AND RETRIEVAL SYSTEM.

UNLESS OTHERWISE SPECIFIED DIMENSIONS ARE IN INCHES. TOLERANCES ON FRACTIONS: DECIMALS 2 ANGLES 2		APPROVED 31 JULY 1952 <i>[Signature]</i> BY DIRECTOR OF THE BUREAU OF ORDNANCE	TRACER CAVITY & PLUG ASSEMBLY DETAIL		BUREAU OF ORDNANCE DEPARTMENT OF THE NAVY U. S. NAVAL ORDNANCE LABORATORY WRITE ONE SLIP PER DRAWING 10, 14, 15, 16, 17, 18, 19, 20, 21, 22, 23, 24, 25, 26, 27, 28, 29, 30, 31, 32, 33, 34, 35, 36, 37, 38, 39, 40, 41, 42, 43, 44, 45, 46, 47, 48, 49, 50, 51, 52, 53, 54, 55, 56, 57, 58, 59, 60, 61, 62, 63, 64, 65, 66, 67, 68, 69, 70, 71, 72, 73, 74, 75, 76, 77, 78, 79, 80, 81, 82, 83, 84, 85, 86, 87, 88, 89, 90, 91, 92, 93, 94, 95, 96, 97, 98, 99, 100
DO NOT SCALE THIS DRAWING		FA <i>[Signature]</i> 7-31-52	SCALE	UNIT WT	JOB ORDER
MATERIAL		FA <i>[Signature]</i> 7-31-52	2		
NEXT ASSY		HD <i>[Signature]</i> 7-31-52	7		
USED ON		CHECKED <i>[Signature]</i> 7-31-52			
APPLICATION		DRAWN <i>[Signature]</i> 7-31-52			
SPECIFICATIONS OF LATEST ISSUE APPLY					

SK. 354673

Figure 1

Figure 2

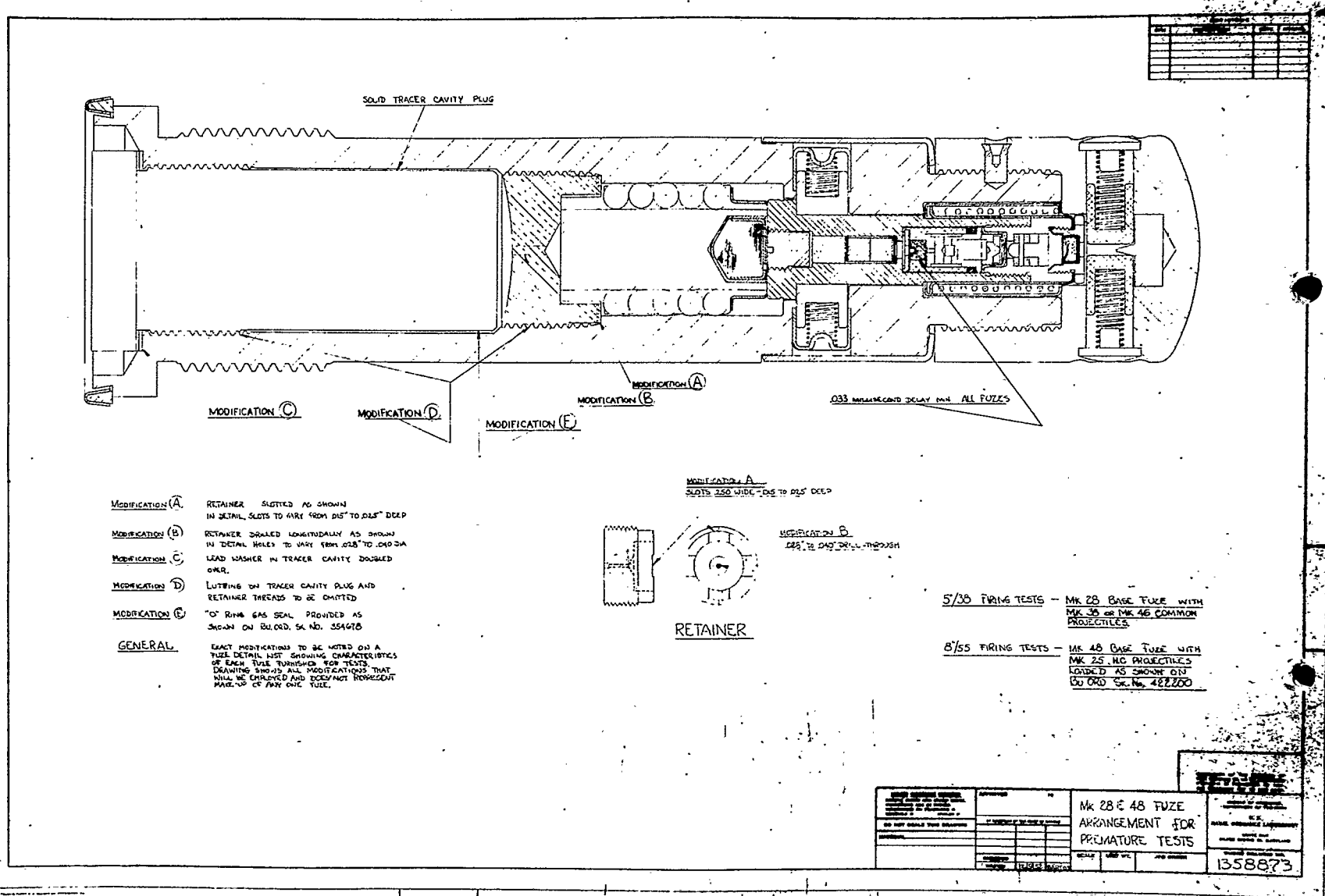

- MODIFICATION (A) RETAINER SLOTTED AS SHOWN IN DETAIL, SLOTS TO VARY FROM .015" TO .015" DEEP
- MODIFICATION (B) RETAINER DRILLED LONGITUDINALLY AS SHOWN IN DETAIL, HOLES TO VARY FROM .028" TO .040" DIA. LEAD WASHER IN TRACER CAVITY DOUBLED OVER.
- MODIFICATION (C) LUTING ON TRACER CAVITY PLUG AND RETAINER THREADS TO BE OMITTED
- MODIFICATION (E) "O" RING GAS SEAL PROVIDED AS SHOWN ON BU ORD. SK NO. 354978

GENERAL
 EXACT MODIFICATIONS TO BE NOTED ON A FUZE DETAIL LIST SHOWING CHARACTERISTICS OF EACH FUZE TURNISHED FOR TESTS. DRAWING SHOWS ALL MODIFICATIONS THAT WILL BE EMPLOYED AND DOES NOT REPRESENT MAKE-UP OF ANY ONE FUZE.

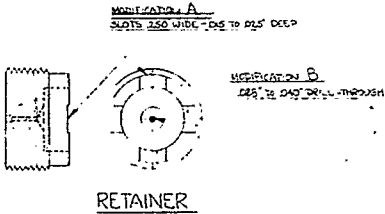

5/30 FIRING TESTS - MK 28 BASE FUZE WITH MK 36 OR MK 46 COMMON PROJECTILES

8/55 FIRING TESTS - MK 48 BASE FUZE WITH MK 25 H.C. PROJECTILES LOADED AS SHOWN ON BU ORD SK. No. 422200

MK 28 & 48 FUZE ARRANGEMENT FOR PREMATURE TESTS		1358873
DRAWN BY:	CHECKED BY:	
DESIGNED BY:	APPROVED BY:	DATE:
MATERIAL:	QUANTITY:	SCALE:

Figure 4

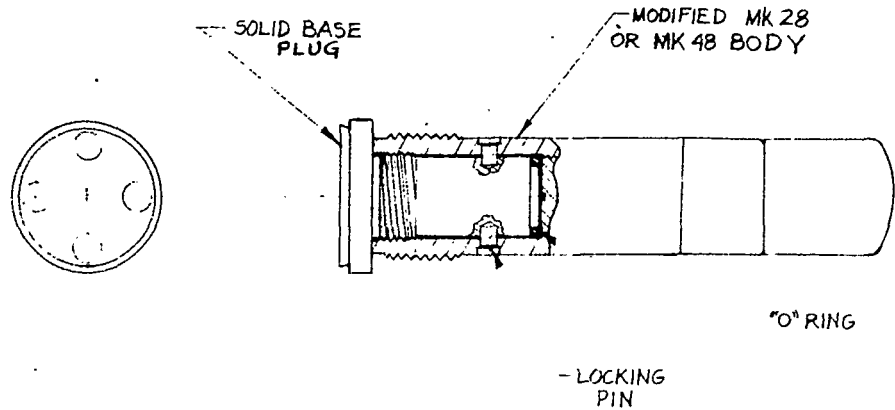

REVISIONS			
SYM	DESCRIPTION	DATE	APPROVAL

THIS DOCUMENT CONTAINS INFORMATION AFFECTING THE NATIONAL DEFENSE OF THE UNITED STATES WITHIN THE MEANING OF THE ESPIONAGE LAWS, TITLE 18, U.S.C., SECTIONS 793 AND 794, THE TRANSMISSION OR THE REVELATION OF ITS CONTENTS IN ANY MANNER TO AN UNAUTHORIZED PERSON IS PROHIBITED BY LAW.

UNLESS OTHERWISE SPECIFIED REMOVE BURRS AND SHARP EDGES DIMENSIONS ARE IN INCHES TOLERANCES ON FRACTIONS - DECIMALS - ANGLES		APPROVED	1059	MODIFIED MK 28 & 48 B.D.F.			BUREAU OF ORDNANCE DEPARTMENT OF THE NAVY
DO NOT SCALE THIS DRAWING		BY DIRECTION OF THE CHIEF OF BUREAU					U 5 NAVAL ORDNANCE LABORATORY
MATERIAL		CHECKED		SCALE	UNIT WT	JOB ORDER	WHITE OAK SILVER SPRING 12, MARYLAND
NEXT ASSY	USED ON	DRAWN		HEE	9/5/53		BUORD DRAWING NO E-12
APPLICATION		SPECIFICATIONS OF LATEST ISSUE APPL.					

REVISIONS			
QTY	DESCRIPTION	DATE	APPROVAL

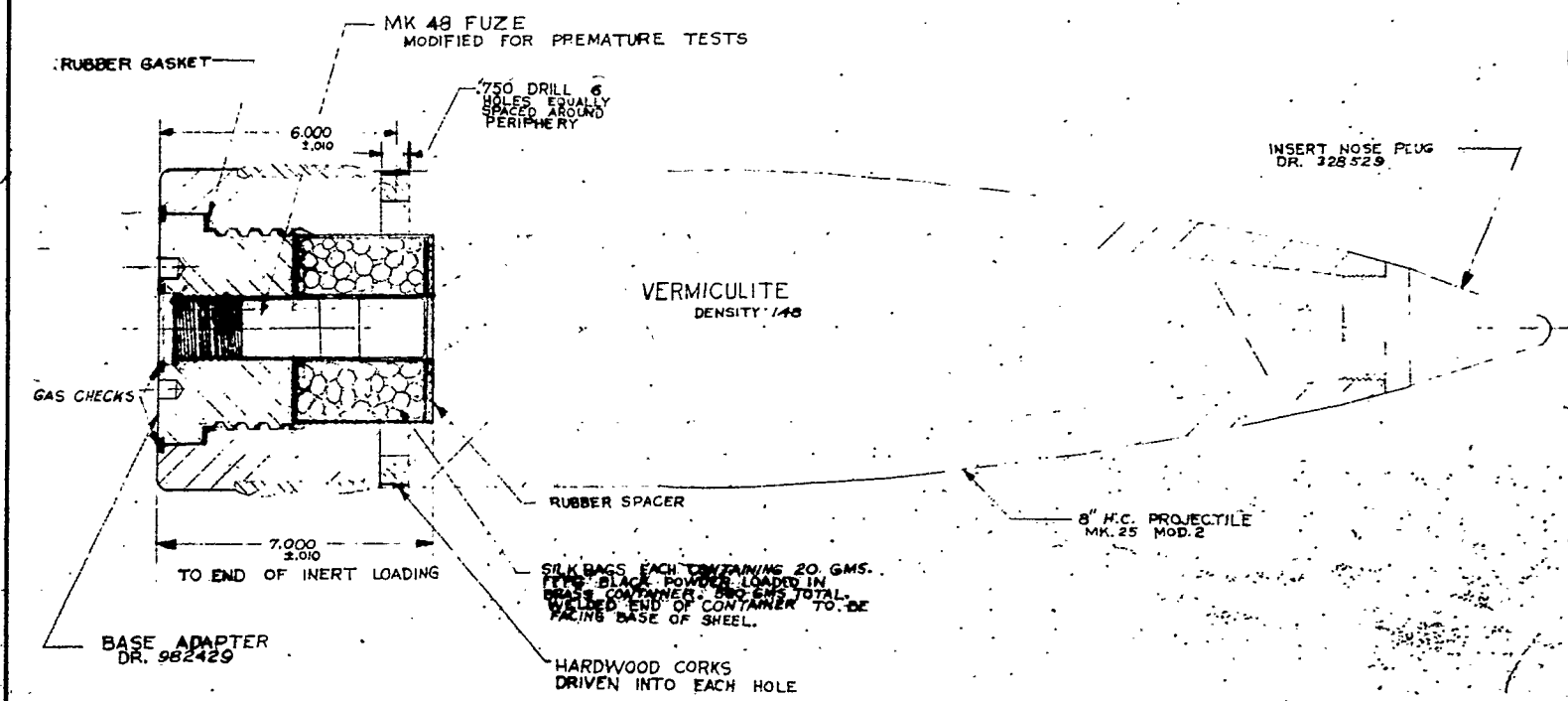
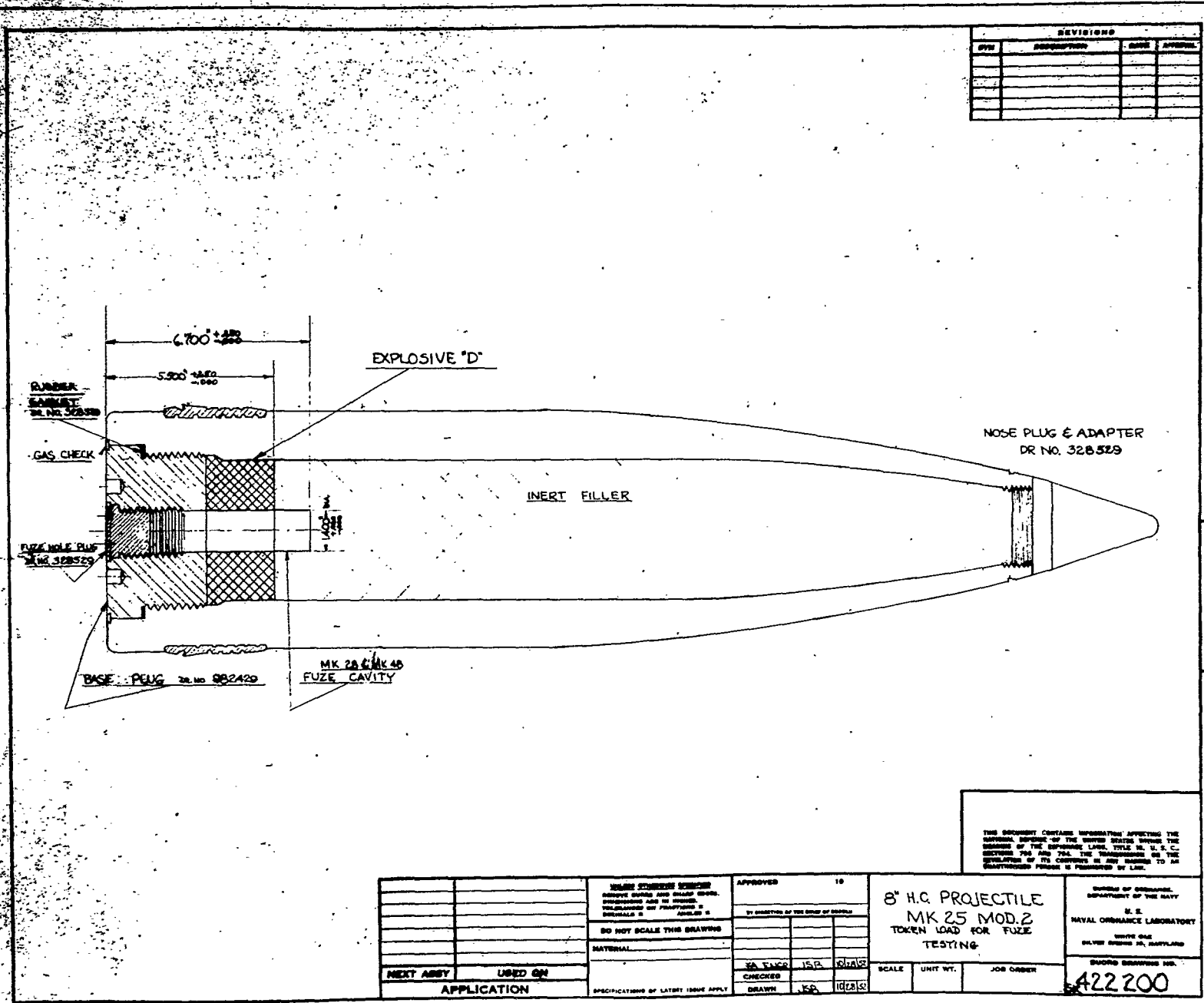

Figure 5

Approval of the contents of this drawing is an acknowledgment of the person or persons by whom the drawing was prepared.

DRAWING CHECKED BY: DATE: _____ CHECKED BY: _____ DATE: _____		APPROVED BY: _____ DATE: _____ BY: _____		SMOKE PUFF TEST FOR MK. 48 FUZE		U.S. NAVAL ORDNANCE LABORATORY 4700 RIFLE PLAZA WASHINGTON, D.C. 20375	
MATERIAL: _____		CHECKED: _____ DRAWN: N.J.S.				SCALE: _____	UNIT WT.: _____
NEXT ASSY: _____ USED ON: _____		APPLICATION: _____		SK 354596		30-1101	

Figures to



REVISIONS			
REV.	DESCRIPTION	DATE	APPROVAL

THIS DOCUMENT CONTAINS INFORMATION AFFECTING THE NATIONAL DEFENSE OF THE UNITED STATES WITHIN THE MEANING OF THE ESPIONAGE LAWS, TITLE 18, U. S. C., SECTIONS 793 AND 794, THE TRANSMISSION OR THE REVELATION OF ITS CONTENTS IN ANY MANNER TO AN UNAUTHORIZED PERSON IS PROHIBITED BY LAW.

MAKE SURE YOU HAVE APPROVED THIS DRAWING BEFORE YOU BEGIN WORK. PROVISIONS ARE IN EFFECT GOVERNMENT OF PROPERTY IS RETAINED BY THE U. S. GOVERNMENT.		APPROVED 10 BY SIGNATURE OF THE HEAD OF OFFICE		8" H.C. PROJECTILE MK 25 MOD. 2 TOKEN LOAD FOR FUZE TESTING		BUREAU OF ORDNANCE, DEPARTMENT OF THE NAVY U. S. NAVAL ORDNANCE LABORATORY WHITE OAK SILVER SPRING MD, MARYLAND	
DO NOT SCALE THIS DRAWING		MATERIAL		SCALE UNIT WT. JOB ORDER		BUREAU DRAWING NO. A22200	
NEXT ASBY USED ON APPLICATION		CHECKER DRAWN		DATE 10/28/53		15P 10/28/53	
SPECIFICATIONS OF LATEST ISSUE APPLY		15P 10/28/53		15P 10/28/53		15P 10/28/53	

FRAG NO. 1697

8" HC. TOKEN LOADED WITH EXPLOSIVE "D" DETONATED IN SAWDUST.

N P 9 NO. 51896

0 - 1/2 Gms.
43 PCS.
Gms.

1/2 - 1 Gms.
33 PCS.
28 Gms.

1 - 2 Gms.
3 PCS.
6 Gms.

2 - 5 Gms.
8 PCS.
29 Gms.

5 - 10 Gms.
10 PCS.
77 Gms.

10 - 20 Gms.
13 PCS.
88 Gms.

20 - 40 Gms.
6 PCS.
71 Gms.

40 - 80 Gms.
15 PCS.
881 Gms.

80 - 160 Gms.
11 PCS.
1241 Gms.

160 - 320 Gms.
17 PCS.
4050 Gms.

FUZE-FRAGS.
10 PCS.
279 Gms.

333 Gms.

336 Gms.

351 Gms.

383 Gms.

387 Gms.

449 Gms.

508 Gms.

679 Gms.

735 Gms.

749 Gms.

756 Gms.

943 Gms.

1055 Gms.

1104 Gms.

1126 Gms.

1165 Gms.

1217 Gms.

1270 Gms.

1376 Gms.

1388 Gms.

1451 Gms.

1515 Gms.

1533 Gms.

1839 Gms.

1876 Gms.

1972 Gms.

2247 Gms.

2387 Gms.

2401 Gms.

2701 Gms.

2846 Gms.

2987 Gms.



108 1/2 LBS.

19.05 LBS.



NP9-64187

24 January 1953

CONFIDENTIAL
SECURITY INFORMATION

Mark 48 BD Fuse No. 128 assembled to 8" Mark 25 token loaded projectile fired at service velocity. Note premature fuze action approximately 215 feet from the muzzle. Round 7.

Figure 9

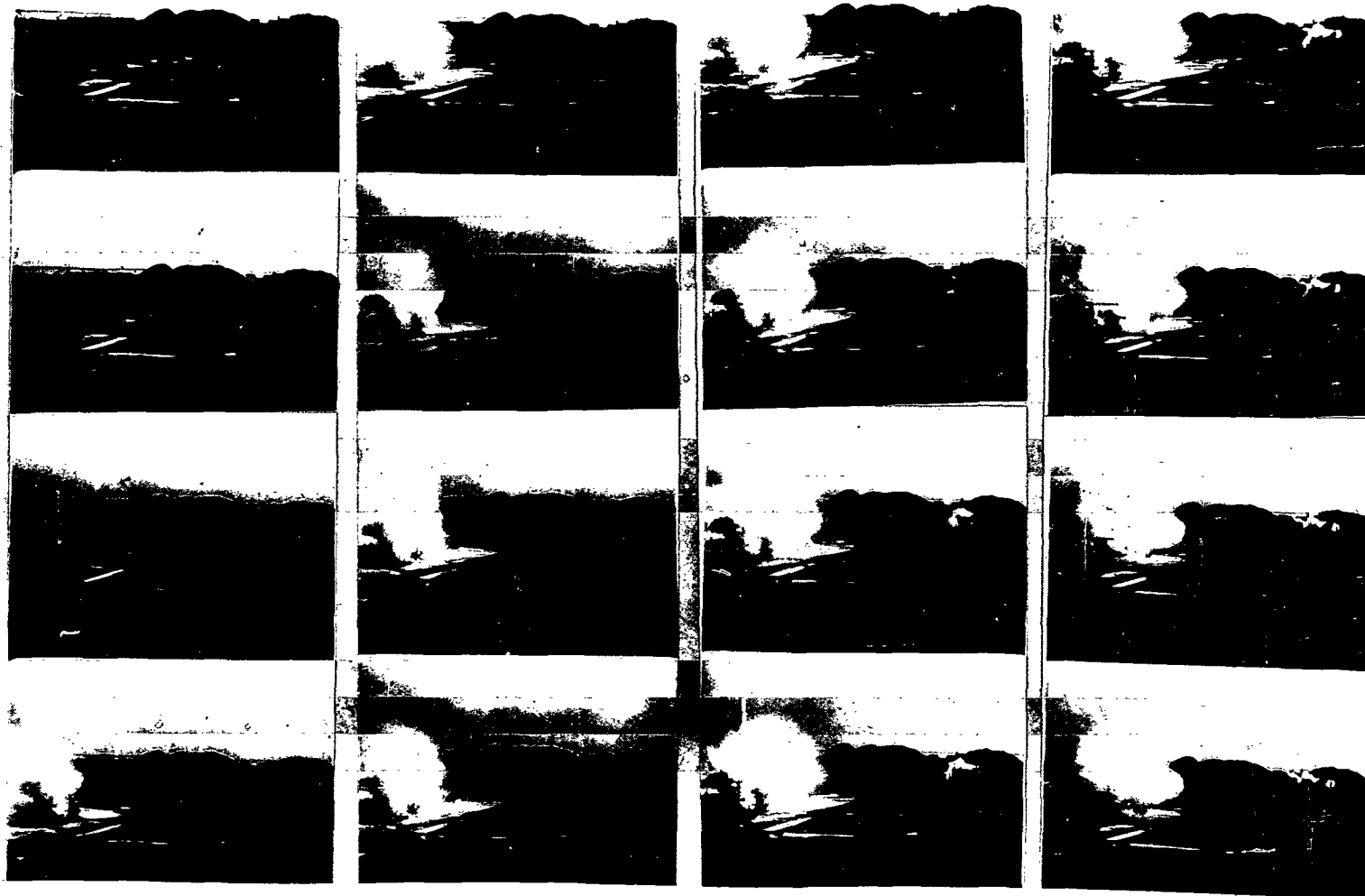

TABLE I
FUZE MODIFICATION CHART

Phase No.	Fuze No.	Cal.	MOD A	MOD B	MOD C	Retainer		Tracer Cav. Plug		MOD D	MOD E
			Depth of 0"250 Wide Slots of Ret.	Size Hole in Ret.	0"025 Lead Washer	Thr.	Torque Ft. Lbs.	Thr.	Torque Ft. Lbs.	Luting	"O" Ring
I	1	8"	None	0"040	D.O.	w/t	30	w/t	30	Yes	None
"	2	"	"	"	"	"	"	"	"	"	"
"	3	"	"	"	"	"	"	"	"	"	"
"	8	"	"	0"125	"	"	"	"	"	"	"
"	9	"	"	"	"	"	"	"	"	"	"
"	10	"	"	"	"	"	"	"	"	"	"
II	1	5"	"	None	"	"	25	"	"	On Ret. Only.	"
"	2	"	"	"	"	"	"	"	"	None	"
"	3	"	"	"	"	"	"	"	"	"	"
"	4	"	"	"	"	"	"	"	"	"	"
"	5	"	0"015	"	"	"	"	"	"	On Ret. Only.	"
"	6	"	"	"	"	"	"	"	"	None	"
"	7	"	0"018	"	"	"	"	"	"	"	"
"	8	"	"	"	"	"	"	"	"	"	"
"	9	"	0"025	"	"	"	"	"	"	"	"
"	10	"	"	"	"	"	"	"	"	"	"
"	11	"	None	0"028	"	"	"	"	"	"	"
"	12	"	"	0"040	"	"	"	"	"	"	"
"	13	"	0"025	None	"	"	"	"	"	"	Yes
"	16	"	None	0"040	"	"	"	Comb.	5	None	None
"	17	"	"	"	"	"	"	"	"	"	"
"	18	"	"	"	"	"	"	"	"	"	"
"	22	"	"	0"098	"	"	"	"	"	"	Yes
"	23	"	"	"	"	"	"	"	"	"	"
"	24	"	"	0"125	"	"	"	"	"	"	"
"	25	"	"	"	"	"	"	"	"	"	"

TABLE I (Continued)

Phase No.	Fuze No.	Cal.	MOD A	MOD B	MOD C	Retainer		Tracer Cav. Plug		MOD D	MOD E
			Depth of 0".250 Wide Slots of Ret.	Size Hole in Ret.	0".025 Lead Washer	Thr.	Torque Ft. Lbs.	Thr.	Torque Ft. Lbs.	Luting	"O" Ring
III	116	8"	None	None	D.O.	w/t	25	w/t	30	On Ret. Only	None
"	117	"	"	"	"	"	"	"	"	None	"
"	118	"	"	"	"	"	"	Comb.	5	"	"
"	123	"	0".018	"	"	"	"	"	"	"	"
"	124	"	0".025	"	"	"	"	"	"	"	"
"	125**	"	"	"	"	"	"	"	2	"	"
"	126	"	None	0".028	"	"	"	"	5	"	"
"	127	"	"	"	"	"	"	"	"	"	"
"	128	"	"	0".040	"	"	"	"	"	"	"
"	130	"	"	"	"	"	"	Comb.	"	"	"
"	131	"	"	"	"	"	"	"	30	"	"
"	132	"	"	"	"	"	"	w/t	5	"	"
"	133	"	"	"	"	"	"	"	30	"	"
"	136	"	"	"	"	"	"	"	5	"	Yes
"	137	"	"	"	"	--	--	"	"	"	"
"	139	"	"	0".125	"	--	--	"	"	"	"
"	140	"	"	"	"	--	--	"	"	"	"
IV	26	5"	"	0".0400.C.	"	w/t	10	Comb.	"	"	"
"	27	"	"	"	"	Comb.	5	"	"	"	"
"	28	"	0".020	"	"	w/t	10	"	20	"	"
"	29	"	0".035x030S.S.	None	"	"	"	"	5	"	"
"	30	"	0".020	"	"	"	"	"	5	"	"
"	31	"	0".035x030S.S.	"	"	"	"	"	"	"	"
"	32	"	0".025	"	"	Comb.	"	"	"	"	"
"	33	"	0".020	"	"	"	"	"	2	"	"
"	33	"	0".025	"	"	Comb.***	"	"	"	"	"
"	34	"	"	"	"	(-".005)	"	"	"	"	"
						(-".010)					

TABLE I (Continued)

Phase No.	Fuze No.	Cal.	MOD A	MOD B	MOD C	Retainer		Tracer Cav. Plug		MOD D	MOD E
			Depth of 0 ⁰ .250 Wide Slots of Ret.	Size Hole in Ret.	0 ⁰ .025 Lead Washer	Thr.	Torque Ft. Lbs.	Thr.	Torque Ft. Lbs.	Luting	"O" Ring
IV	35	5"	0 ⁰ .020	None	D.O.	Comb. (- ⁰ .015)	2	Comb.	5	None	Yes
"	36	"	"	"	"	Comb. (- ⁰ .020)	"	"	2	"	"
"	37	"	None	"	"	Comb. (- ⁰ .010)	-1/4T	"	"	"	"
"	38	"									
"	39	"									

** 125 - Tracer plug was hand seated, it protruded from base 0⁰.040 - 0⁰.050.

*** Comb.(-⁰.005) = combed 0⁰.005 under minimum Tolerances.

TABLE I (Continued)

Phase No.	Fuze No.	Retainer				Tracer Cavity Plug			Luting	"O" Ring	0.025 Lead Washer	
		Thr.	Torque Ft. Lbs.	B.C.V.	MOD B	MOD A	Threads	Torque Ft. Lbs.				B.C.V.
V	141	w/t	40	Yes	0.040 O.C.	---	Comb.	5	Yes	Ret. Only	None	D.O.
"	143	"	"	"	0.055 O.C.	---	"	"	"	"	"	"
"	145	"	"	"	0.075 O.C.	---	"	"	"	"	"	"
"	146	"	"	"	0.040 O.C.	---	"	"	No	"	"	"
"	147	"	"	"	0.055 O.C.	---	"	"	"	"	"	"
"	149	"	"	No	0.040 O.C.	---	"	"	"	None	"	"
"	150	"	"	"	---	0.020	"	10	"	"	"	"
						0.035x0.030 S.S.						
"	152	Comb.	"	"	---	0.020	Comb.	5	"	"	"	"
"	153	Comb. (-0.020)	"	"	---	0.020	"	"	"	"	"	"

Thr. = threads

D.O. = doubled over

w/t = with tolerances

ss = side slots passing through threads parallel to longitudinal axis

O.C. = off center

-1/4T = hand seated and backed off 1/4 turn

Comb. = threads combed to minimum tolerances

Ret. = retainer

B.C.V. = Ball check value

Mark 48 and Mark 28 Projectile Fuzes; Ballistic Tests of

TABLE II
DETAILED FIRING RECORD

PHASE I

<u>Date</u>	<u>Gun No.</u>	<u>Rd. No.</u>	<u>Fuze No.</u>	<u>Muzzle Velocity (f/s)</u>	<u>Target</u>			<u>Fuze* Action</u>
					<u>Mat.</u>	<u>Obl.</u>	<u>Range</u>	
9-17-52	560L	1	1	1836	3/4" STS	0°	500 ft.	NFA
"	"	2	2	1827	" "	"	"	"
"	"	3	3	1830	" "	"	"	"
10-1-52	737	4	8	2808	1" STS	"	"	"
"	"	5	9	--	" "	"	"	"
"	"	6	10	2767	" "	"	"	"

*Fuze Action: NFA = no fuze action (smoke puff) observed.

Guns: 8"/35 Mark A Mod 1 Gun No. 560L
8"/55 Mark 15 Mod 2 Gun No. 737

Fuze: Mark 48

Mark 48 and Mark 28 Projectile Fuzes; Ballistic Tests of

TABLE II (Continued)

PHASE II

Date	Rd. No.	Fuze No.	Chamber Pressure T/in ²	Approx. Muzzle Velocity (f/s)	Target		Approx. Range	Fuze* Action
					Mat.	Obl.		
12-24-52	1	1	13.4	2600	Down River		11,000 yds.	NFA
"	2	2	16.2	2600	" "		11,000 yds.	"
"	3	3	5.9	1200	" "		6,000 yds.	"
"	4	4	15.0	2600	" "		11,000 yds.	"
"	5	5	5.9	1200	" "		6,000 yds.	"
12-29-52	6	6	5.8	1200	" "		6,000 yds.	"
"	7	7	14.9	2600	" "		12,000 yds.	"
"	8	8	5.8	1200	" "		6,000 yds.	"
"	9	9	15.0	2600	" "		12,000 yds.	"
"	10	10	5.9	1200	" "		6,000 yds.	"
"	11	11	15.1	2600	" "		12,000 yds.	"
"	12	12	5.9	1200	" "		6,000 yds.	"
1-2-53	13	13	16.0	2600	1/2" STS	0°	500 ft.	HO-30 ft. behind target
1-12-53	14	16	15.3	2600	Down River		12,000 yds.	Prem. - 100 ft.
"	15	17	15.7	2600	" "		12,000 yds.	Prem. - 100 ft.
"	16	18	15.4	2600	" "		12,000 yds.	Prem. - 100 ft.
"	17	22	15.6	2600	" "		12,000 yds.	NFA
"	18	23	15.4	2600	" "		12,000 yds.	"
"	19	24	16.1	2600	" "		12,000 yds.	"
"	20	25	15.3	2600	" "		12,000 yds.	"

*Fuze Action: NFA = no fuze action observed on water impact.
 HO = high order detonation.
 Prem. - 100 = premature fuze action 100 ft. from gun muzzle.

Gun: 5"/38 Mark 12 Mod 1 Gun No. 5015

Fuze: Mark 28

Mark 48 and Mark 28 Projectile Fuzes; Ballistic Tests of

TABLE II (Continued)

PHASE III

Date	Rd. No.	Fuze No.	Chamber Pressure T/in ²	Approx. Muzzle Velocity (f/s)	Target			Fuze* Action
					Mat.	Obl.	Range	
1-22-53	1	116	10.8	2200	3/4" STS	0°	450 ft.	HO behind target.
"	2	117	11.4	"	" "	"	"	" " "
"	3	118	11.5	"	" "	"	"	" " "
"	4	123	11.7	"	" "	"	"	" " "
"	5	126	11.8	"	" "	"	"	" " "
1-24-53	6	127	12.0	"	" "	"	"	" " "
"	7	128	14.4	Service	" "	"	"	Premature - 215 ft.
"	8	124	14.6	"	" "	"	"	HO behind target.
"	9	136	14.9	"	" "	"	"	" " "
"	10	137	14.7	"	" "	"	"	LO behind target.
"	11	139	14.6	"	" "	"	"	HO behind target.
"	12	140	14.0	"	" "	"	"	Dud
"	13	133	14.7	"	" "	"	"	HO behind target.
"	14	132	14.7	"	" "	"	"	Dud
"	15	131	14.2	"	" "	"	"	LO on water impact, dud on target
"	16	125	14.5	"	" "	"	"	HO behind target
"	17	130	14.5	"	" "	"	"	" " "

*Fuze Action: HO = high order detonation.

LO = low order detonation.

Dud = no fuze action.

Premature - 215 ft. = premature fuze action 215 ft. from the muzzle.

Gun: 8"/55 Mark 15 Mod 0 No. 838.

Fuze: Mark 48

CONFIDENTIAL

NPG REPORT NO. 1205

Mark 48 and Mark 28 Projectile Fuzes; Ballistic Tests of

TABLE II (Continued)

PHASE IV

Date	Rd. No.	Fuze No.	Chamber Pressure T/in ²	Approx. Muzzle Velocity (f/s)	Target			Fuze Action
					Mat.	Obl.	Range	
2-17-53	1	26	14.4	2600	Down River		12,000 yds.	NFA
"	2	27	15.4	"	"	"	"	"
"	3	28	15.0	"	"	"	"	"
"	4	29	--	"	"	"	"	"
"	5	30	15.2	"	"	"	"	"
"	6	33	15.1	"	"	"	"	"
"	7	34	14.4	"	"	"	"	"
"	8	35	--	"	"	"	"	"
"	9	36	15.0	"	"	"	"	"
"	10	37	15.0	"	"	"	"	"
2-20-53	11	31	15.0	"	1/2" STS	0°	450 ft.	HO-45 ft. behind target.
"	12	32	15.0	"	"	"	"	HO-90 ft. behind target.
2-24-53	13	39	14.4	"	Sand	"	"	For recovery.
"	14	38	--	"	1" STS	"	"	" "

Gun: 5"/38 Mark 12 Mod 1 Gun No. 5015

Fuze: Mark 28

CONFIDENTIAL
SECURITY INFORMATION

Mark 48 and Mark 28 Projectile Fuzes; Ballistic Tests of

TABLE II (Continued)PHASE V

<u>Date</u>	<u>Rd. No.</u>	<u>Fuze No.</u>	<u>Chamber Pressure T/in²</u>	<u>Approx. Muzzle Velocity (f/s)</u>	<u>Target</u>		<u>Approx. Range</u>	<u>Fuze* Action</u>
					<u>Mat.</u>	<u>Obl.</u>		
3-17-53	1	141	14.1	2800	Down	River	12,000 yds.	NFA
"	2	143	14.4	2800	"	"	"	"
"	3	145	11.8	2200	"	"	"	"
"	4	146	13.2	2200	"	"	"	"
"	5	147	14.4	2800	"	"	16,000 yds.	"
"	6	149	14.6	2800	"	"	"	"
"	7	152	14.8	2800	"	"	"	"
"	8	153	13.4	2200	"	"	12,000 yds.	"
"	9	150	14.3	2800	"	"	16,000 yds.	"

*Fuze Action: NFA = no fuze action observed.

Gun: 8"/55 Mark 15 Mod O Gun No. 838

Fuze: Mark 48

Mark 48 and Mark 28 Projectile Fuzes; Ballistic Tests of

TABLE II (Continued)

PHASE VI

Date	Rd. No.	Chamber Pressure T/in ²	Approx. Muzzle Velocity (f/s)	Target			Fuze * Action
				Mat.	Obl.	Range	
5-5-53	1	--	1200	Down	River	5,000 yds.	HOWI
"	2	19.8	Proof	"	"	12,000 yds.	"
"	3	20.1	"	"	"	"	"
"	4	19.9	"	"	"	"	"
"	5	20.2	"	"	"	"	"
"	6	--	1200	"	"	5,000 yds.	HOWI
"	7	--	"	"	"	"	"
"	8	--	"	"	"	"	"
"	9	--	"	"	"	"	"
5-6-53	10	--	"	"	"	"	Not observed
"	11	19.8	Proof	"	"	12,000 yds.	"
"	12	20.9	"	"	"	"	HOWI
"	13	--	1200	"	"	5,000 yds.	"
"	14	--	"	"	"	"	"
"	15	--	"	"	"	"	Dud
"	16	20.8	Proof	"	"	12,000 yds.	HOWI
"	17	20.5	"	"	"	"	"
"	18	21.2	"	"	"	"	"
5-11-53	19	--	1200	"	"	5,000 yds.	HOWI
5-14-53	20	19.2	Proof	"	"	12,000 yds.	"
"	21	20.5	"	"	"	"	"
"	22	20.6	"	"	"	"	"
"	23	20.8	"	"	"	"	"
"	24	20.8	"	"	"	"	Not observed
"	25	20.7	"	"	"	"	HOWI

*Fuze Action: HOWI = high order detonation on water impact

Dud = no fuze action

Not observed = fuze functioning or projectile impact was not observed by look-out personnel owing to poor range - visibility.

Gun: 5"/38 Mark 12 Mod 0 Gun No. 5015

Fuze: Mark 28

Mark 48 and Mark 28 Projectile Fuzes; Ballistic Tests of

TABLE II (Continued)

PHASE VII

Date	Rd. No.	Chamber Pressure T(in ²)	Approx. Muzzle Velocity (f/s)	Target		Approx. Range	Fuze* Action
				Mat.	Obl.		
7-1-53	1	11.5	2200	Down	River	10,000 yds.	HOWI
"	2	17.8	Proof	"	"	15,500 yds.	"
"	3	12.3	2200	"	"	10,000 yds.	"
7-2-53	4	11.7	2200	"	"	"	"
"	5	18.3	Proof	"	"	16,200 yds.	"
"	6	21.6	Proof	"	"	"	"
"	7	12.1	2200	"	"	10,000 yds.	"
7-8-53	8	11.5	2200	"	"	"	"
"	9	22.0	Proof	"	"	16,500 yds.	"
"	10	22.4	Proof	"	"	"	"
"	11	22.0	Proof	"	"	"	"
"	12	11.1	2200	"	"	10,000 yds.	Dud
"	13	22.0	Proof	"	"	16,500 yds.	HOWI
"	14	21.7	Proof	"	"	"	"
"	15	22.7	Proof	"	"	"	"
"	16	11.2	2200	"	"	10,000 yds.	"
"	17	21.8	Proof	"	"	16,500 yds.	"
7-9-53	18	11.5	2200	"	"	10,000 yds.	"
"	19	20.6	Proof	"	"	16,000 yds.	"
"	20	21.1	Proof	"	"	"	"
"	21	21.7	Proof	"	"	"	"
"	22	11.6	2200	"	"	10,000 yds.	"
"	23	20.6	Proof	"	"	16,000 yds.	"
"	24	21.3	Proof	"	"	"	"
"	25	11.8	2200	"	"	10,000 yds.	"

*Fuze Action: HOWI = high order detonation on water impact
Dud = no fuze action.

Gun: 8"/55 Mark 15 Mod 0 Gun No. 838

Fuze: Mark 48