

UNCLASSIFIED

AD NUMBER
AD361203
CLASSIFICATION CHANGES
TO
unclassified
FROM
confidential
AUTHORITY
31 Oct 1976, DoDD 5200.10

THIS PAGE IS UNCLASSIFIED

**CONFIDENTIAL**

**AD**

**3 6 1 2 0 3L**

**DEFENSE DOCUMENTATION CENTER**

**FOR**

**SCIENTIFIC AND TECHNICAL INFORMATION**

**CAMERON STATION, ALEXANDRIA, VIRGINIA**



**CONFIDENTIAL**

**NOTICE:** When government or other drawings, specifications or other data are used for any purpose other than in connection with a definitely related government procurement operation, the U. S. Government thereby incurs no responsibility, nor any obligation whatsoever; and the fact that the Government may have formulated, furnished, or in any way supplied the said drawings, specifications, or other data is not to be regarded by implication or otherwise as in any manner licensing the holder or any other person or corporation, or conveying any rights or permission to manufacture, use or sell any patented invention that may in any way be related thereto.

NOTICE:

THIS DOCUMENT CONTAINS INFORMATION  
AFFECTING THE NATIONAL DEFENSE OF  
THE UNITED STATES WITHIN THE MEAN-  
ING OF THE ESPIONAGE LAWS, TITLE 18,  
U.S.C., SECTIONS 793 and 794. THE  
TRANSMISSION OR THE REVELATION OF  
ITS CONTENTS IN ANY MANNER TO AN  
UNAUTHORIZED PERSON IS PROHIBITED  
BY LAW.

**CONFIDENTIAL**

GROUP 4  
Downgraded at 3-year intervals;  
declassified after 12 years.

17 Rept. no.  
NOTS-TP-3431-Rev. 1

REVISION 1  
COPY ~~24~~

AD No. 361203

DDC FILE COPY

361203L

6 CLUSTER BOMB MARK 15 MOD 0

(SADEYE WEAPON SYSTEM),

Description and Operation.

(A PRELIMINARY MANUAL) (5)

U. S. Government Agencies may obtain copies of this report direct from DDC. Other qualified DDC users should request through the Chief, Bureau of Naval Weapons, Washington, D.C. 20360 or U.S. Naval Ordnance Test Station, China Lake, Calif. 93557.



5 NAVAL ORDNANCE TEST STATION  
China Lake, California

11 October 1964

12 127p.

**CONFIDENTIAL**



DOCUMENT RELEASE STATUS  
NAVWEPS FORM 3900/3 (REV. 2-64)

THIS PAPER IS CHEMICALLY TREATED. NO CARBON PAPER IS REQUIRED

AD NUMBER  
(To be  
inserted  
by DDC)

CLASSIFICATION

ORIGINATING AGENCY

REPORT SERIES AND NUMBER

**CONFIDENTIAL**

UNCLASSIFIED WHEN ENCLOSURE IS REMOVED

U. S. Naval Ordnance Test  
Station, China Lake, Calif. 93557  
ENCLOSURE (REPORT TITLE)  
CLASSIFIED BOMB MARK 1, M10 G (SAFETY  
WEAPON SYSTEM) Description and Operation

REPORT DATE  
October 1964  
COG. BUWEPS CODE (For  
use in BUWEPS only)

TO Administrator  
Defense Documentation Center for Scientific  
and Technical Information (DDC)  
Bldg. #5, Cameron Station  
Alexandria, Virginia 22314

CONTRACT/PROJECT/WEPTASK NUMBER

3113-011/216-1/1003-2-003

SECURITY CLASSIFICATION

UNCLAS. CONF. SECRET

REPORT

TITLE OR SUBJECT

ABSTRACT OR SUMMARY

Enclosure is forwarded for distribution subject to limitations checked below. Request AD number be inserted in space above; one copy of this letter be returned to originating activity if shown below; and two copies be sent to Chief, Bureau of Naval Weapons.

Qualified requesters may obtain copies of this report direct from DDC.	U.S. Government Agencies may obtain copies of this report direct from DDC. Other qualified DDC users should request through no source. (Not available to non-Government DDC users.)
Qualified requesters may obtain copies of this report direct from DDC. Foreign announcement and dissemination of this report by DDC is not authorized.	
U.S. Government Agencies may obtain copies of this report direct from DDC. Other qualified DDC users should request through the Chief, Bureau of Naval Weapons, Washington, D.C. 20360.	U.S. Military Agencies may obtain copies of this report direct from DDC. Other qualified DDC users should request through no source. (Not available to non-military DDC users.)
U.S. Military Agencies may obtain copies of this report direct from DDC. Other qualified DDC users should request through the Chief, Bureau of Naval Weapons, Washington, D.C. 20360.	
All distribution of this report is controlled. Qualified DDC users should request through the Chief, Bureau of Naval Weapons, Washington, D.C. 20360.	

SIGNATURE

TITLE

HEAD, DESIGNATION OFFICE

Chief, Bureau of Naval Weapons (DLI-302)  
Navy Department  
Washington, D.C. 20360

CODE

DATE

CLASSIFICATION

**CONFIDENTIAL**

UNCLASSIFIED WHEN ENCLOSURE IS REMOVED

0140-390-0032

CONTENTS

Chapter	Page
1 INTRODUCTION . . . . .	1-1
1-1 General Characteristics . . . . .	1-1
1-2 Operating Characteristics . . . . .	1-1
1-3 Major Components and Containers . . . . .	1-1
1-4 Handling Equipment . . . . .	1-1
2 PHYSICAL DESCRIPTION . . . . .	2-1
2-1 Universal Weapon Dispenser, Mk 5 Mod 0 . . . . .	2-1
2-2 Fins . . . . .	2-1
2-3 M907 Mechanical Time Fuze . . . . .	2-1
2-4 Arming Wire . . . . .	2-3
2-5 Containers . . . . .	2-3
2-6 Handling Equipment . . . . .	2-4
3 FUNCTIONAL DESCRIPTION . . . . .	3-1
4 OPERATION . . . . .	4-1
4-1 Decanning . . . . .	4-1
4-2 Assembly . . . . .	4-2
4-3 Aircraft Loading . . . . .	4-4
4-4 Unloading Cluster Bomb Mk 15 Mod 0 From Aircraft . . . . .	4-5
4-5 Disassembly . . . . .	4-6

ILLUSTRATIONS

Figure	Page
Frontispiece . . . . .	vi
2-1. Sectioned View of Dispenser . . . . .	2-2
2-2. Fins . . . . .	2-2
2-3. Arming Wire, Fahnestock Clips, M907 Mechanical Time Fuze, and Arming Vane . .	2-3
2-4. Container for Dispenser . . . . .	2-4
3-1. Case Separation Action . . . . .	3-1

Figure	Page
4-1. Lid Lifted from Container . . . . .	4-1
4-2. Chain Hoist Attached to Dispenser . . . . .	4-1
4-3. Dispenser on Aero 12B Bomb Skid With Soft-Shell Adapter Slings . . . . .	4-2
4-4. Fins Attached to Dispenser . . . . .	4-2
4-5. Arming Wire Inserted Through Dispenser . . . . .	4-3
4-6. Fuze Screwed Into Fuze Well of Dispenser . . . . .	4-3
4-7. Arming Wire Aligned . . . . .	4-3
4-8. Fahnestock Clips Attached to Arming Wire . . . . .	4-4
4-9. Sway Braces Tightened on Bomb . . . . .	4-5
4-10. Lever Locking Pin Assembly Removed . . .	4-5
4-11. Safety Wire Removed . . . . .	4-5

**CONFIDENTIAL**

**SAFETY SUMMARY**

The following **WARNING** is repeated from the text for the protection of personnel.

**WARNING**

**DO NOT** remove the fuze safety wire until the weapon is on the aircraft and the aircraft is ready for takeoff. (Page 4-4)

The following **CAUTION** is repeated from the text because if not strictly observed the effectiveness of the weapon may be destroyed.

**CAUTION**

**DO NOT** use suspension lugs for handling the weapon. The suspension bands are accurately positioned to assure proper alignment when installed on the bomb rack. (Page 4-1)

**CONFIDENTIAL**

CONFIDENTIAL

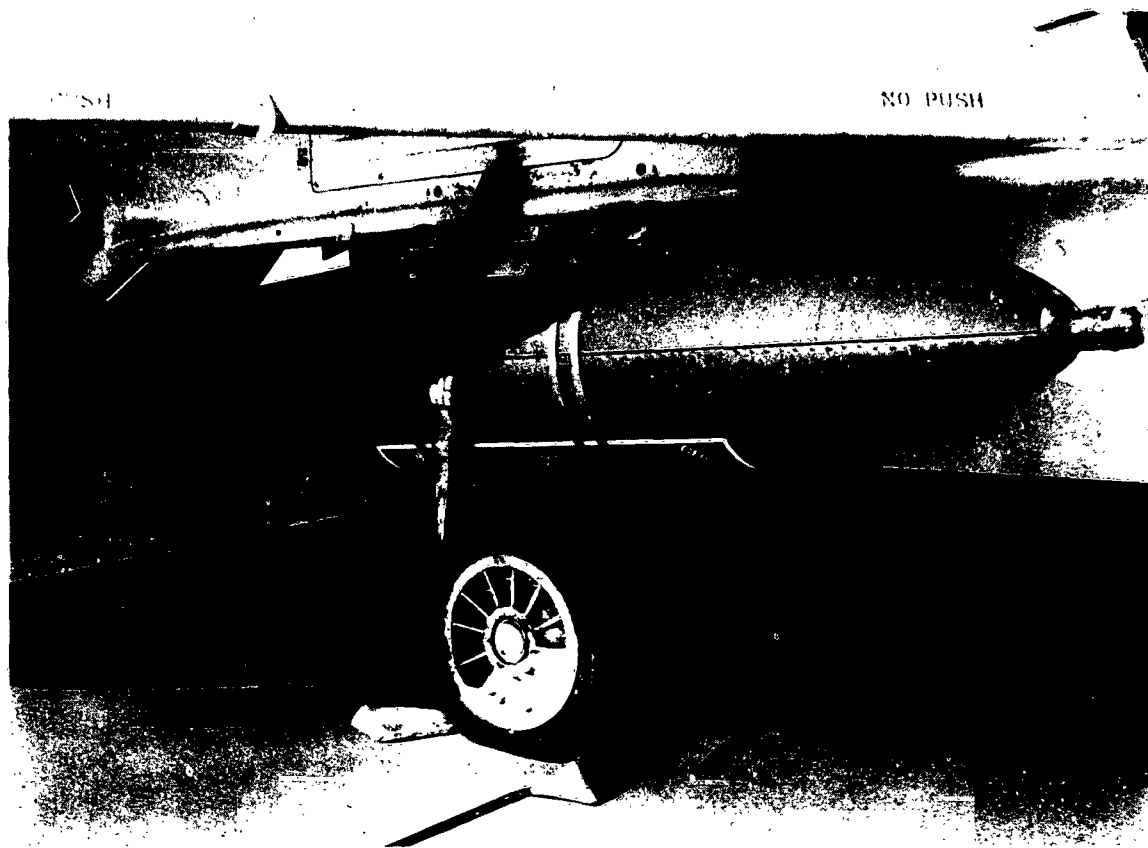

Cluster Bomb Mk 15 Mod 0 (Sadeye) Mounted on Aircraft.

Chapter 1

INTRODUCTION

The Universal Weapon Dispenser Mk 5 Mod 0 (Sadeye) is a low-drag dispenser used to saturate large elliptical areas with in-stock bomblets and submissiles as payloads, (frontis-piece). For this publication, the Army developed M40 bomblet is described as the payload. The weapon dispenser, when loaded with M40 bomblets, is designated the Cluster Bomb Mk 15 Mod 0.

Sadeye can be carried by all modern high-performance aircraft equipped with standard 14-inch suspension bomb racks, can be delivered in all modes (level, glide, dive, toss, and loft), and has a highly predictable ballistic trajectory. As an antipersonnel weapon, it is effective in close support against mortar, gun emplacements, and exposed troops.

Release altitude, ft. . . . . 2000 to 10,000  
 Release speed (max.), knots . . . . . 550  
 Saturation pattern . . . . . Elliptical, several hundred feet in diameter  
 Operating temperature, °F . . . . . -65 to +160  
 Storage temperature limits, °F . . . . . -65 to +160

1-3 MAJOR COMPONENTS AND CONTAINERS

The major components of the Cluster Bomb Mk 15 Mod 0 and their containers are listed in the following paragraphs.

1-3.1 COMPONENTS

- Mk 5 Mod 0 universal weapon dispenser body
- Four fins (packaged separately)
- AN-M6A2 arming wire with Fahnestock clips
- M907 mechanical time fuze with Arming Vane T5E2
- 2100 M40 bomblets

1-3.2 CONTAINERS

- Shipping and Storage Container Mk 320 Mod 0 for dispenser and fins
- Container for fuzes and arming vanes (no mark or mod assigned as yet)

1-4 HANDLING EQUIPMENT

The following types of equipment are required for handling and transporting the Cluster Bomb Mk 15 Mod 0:

- Hoist Mk 8 Mod 0 or Mk 14 Mod 0
- Aero 12B or 12C Bomb Skid (with soft-shell adapter slings)
- Forklift truck
- Mk 7 Bomb Trailer

1-1 GENERAL CHARACTERISTICS

The general characteristics of the Cluster Bomb Mk 15 Mod 0 are as follows:

Length, in. . . . .	88
Diameter, in. . . . .	16
Weight, empty, lb . . . . .	150
Weight, loaded, lb . . . . .	750
Fin span, in. . . . .	30
CG, in. from nose end . . . . .	40

1-2 OPERATING CHARACTERISTICS

The operating characteristics of the Cluster Bomb Mk 15 Mod 0 are as follows:

Chapter 2

PHYSICAL DESCRIPTION

The Cluster Bomb Mk 15 Mod 0 is a semimonocoque (skin-stressed) structure with a low-drag aerodynamic profile, loaded with M40 bomblets. The fins and fuze, as well as the arming vane and arming wire, are attached by the using activity.

The major components of the Cluster Bomb Mk 15 Mod 0 are discussed in the following paragraphs.

2-1 UNIVERSAL WEAPON DISPENSER MK 5 MOD 0

The dispenser is divided in half longitudinally. The upper half contains the strongback section; the lower half contains a hardshell doubler for chocking purposes. The skin of the dispenser is of low carbon steel (1008 to 1020). The two halves are locked together by a nose locking ring at the forward end and by an end plate screwed to the after end. Two suspension bands, approximately 32 1/2 and 45 inches from the forward end, encircle the two halves. The bands are held by levers with locking pins. Midway between the two suspension bands is the hoisting lug receptacle. Openings for the arming wire are covered with appropriate decals.

The dispenser is shipped from the manufacturer as an integral unit. The empty dispenser weighs approximately 150 pounds. Figure 2-1 shows a sectioned view of the dispenser.

At the loading activity, the end plate and loading port plug are removed, and the bomblets are loaded into the dispenser, using special remotely operated machinery. The loading port plug and end plate are then reassembled on the dispenser and the loaded unit is ready for issue to the Fleet. The dispenser, when loaded with approximately 2100 M40 bomblets, weighs about 750 pounds.

2-2 FINS

Four fins, figure 2-2, are attached to the after end of the dispenser body. They are canted 1 1/4 degrees to impart spin to the dispenser when released from the aircraft.

The fins are of cast aluminum alloy with one coat of olive drab enamel over two primer coats. The fins are shipped in a cardboard carton inside the container for the dispenser. Capscrews and washers are also shipped in the carton and are used to attach the fins to the body of the dispenser.

2-3 M907 MECHANICAL TIME FUZE

The M907 fuze, figure 2-3, is an air-armed, air-burst mechanical time fuze with a black-powder booster. It is an in-stock item developed by the U. S. Army.

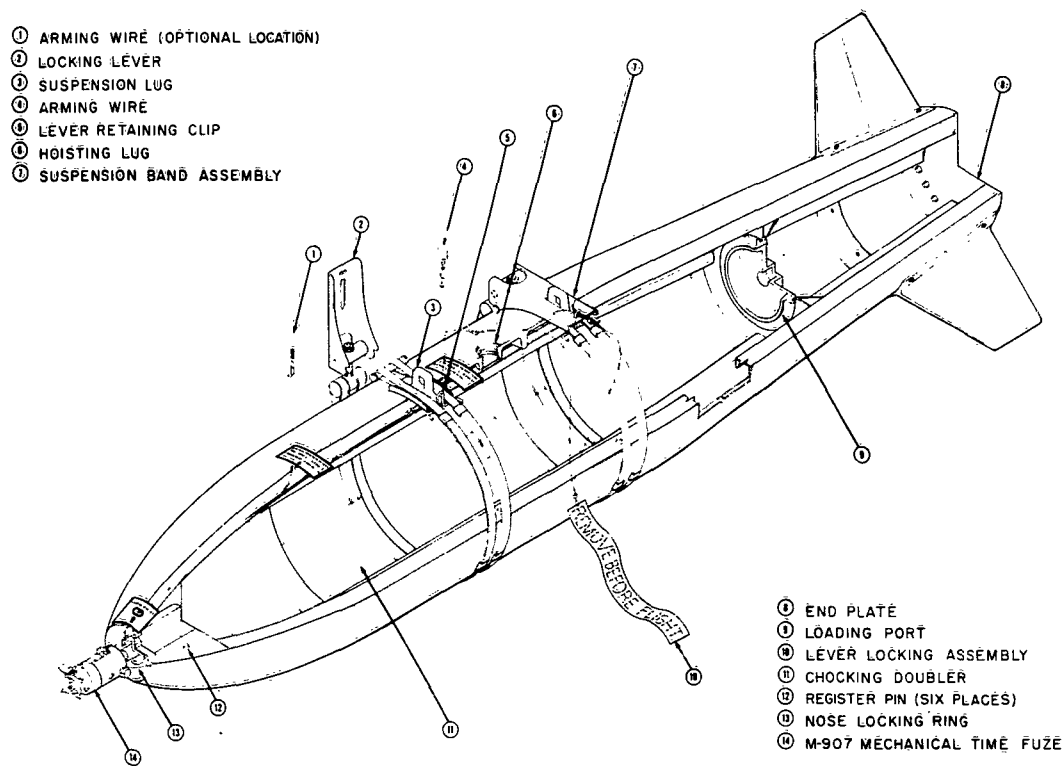

Figure 2-1. Sectioned View of Dispenser.

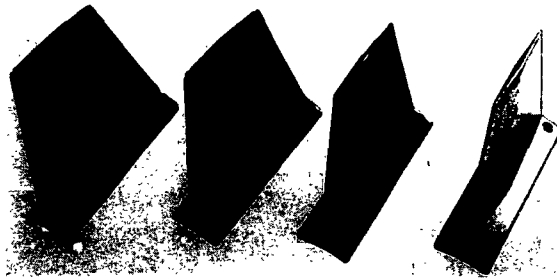

Figure 2-2. Fins.

The M907 fuze is attached to the nose of the weapon dispenser and uses a T5E2 arming vane, figure 2-3. The fuze has a governor mechanism that provides a constant rate of arming independent of vane input speed and function times (set by weapons

assembly personnel on the ground) from 4 to 92 seconds in 0.5-second increments (4 seconds is the functioning time generally used for the weapon dispenser). The arming time of the fuze is built in and is approximately 60 percent of the set functioning time ( $\pm 20$  percent).

The M907 fuze has an interrupted firing train until arming is completed. Visual means of making sure the fuze is unarmed are provided by two viewing ports and the seal over the slider cavity.

Twelve fuzes, individually wrapped in styrofoam and pressure-sealed in a barrier bag, are shipped in a wooden crate. Arming vanes (T5E2) are shipped with the fuzes.

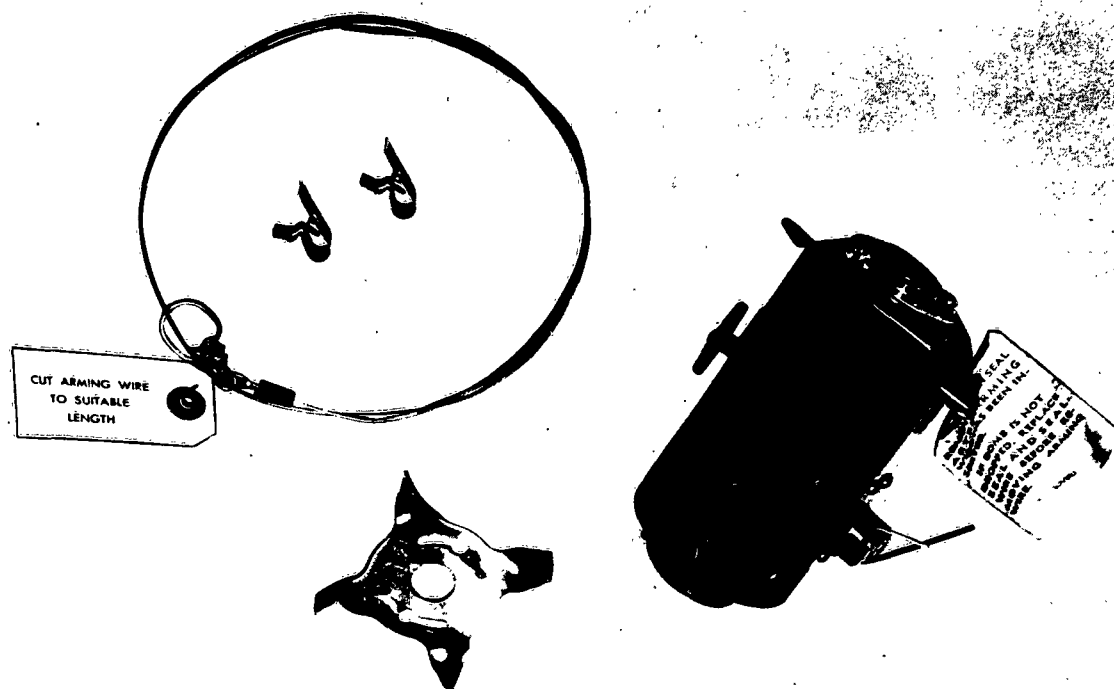

Figure 2-3. Arming Wire, Fahnestock Clips, M907 Mechanical Time Fuze, and Arming Vane.

#### 2-4 ARMING WIRE

The arming wire to be used is a standard hard brass Arming Wire AN-M6A2, figure 2-3. The looped end of the arming wire is attached to the appropriate bomb rack arming wire solenoid; the other end is threaded through the dispenser body, then through openings in the fuze and arming vane plate, and secured with two Fahnestock clips as is normal for aircraft ordnance fuzing. The entrance points for the arming wire are indicated on decals on the dispenser body. For those bomb racks equipped with arming wire attach solenoids between the suspension lugs, the arming wire is inserted through the aft entrance hole; for bomb racks with solenoids forward of the lugs, the arming wire is inserted through the forward entrance hole.

#### 2-5 CONTAINERS

2-5.1 UNIVERSAL WEAPON DISPENSER. The metal, reusable Shipping and Storage Container Mk 320 Mod 0, used to ship the weapon dispenser, is of clamshell construction, held together by 10 clamps, figure 2-4. Two handles, one at each end, are used to lift the top half of the container but are not used for lifting the container with a loaded dispenser.

Two lift pockets on the bottom of the container are used for forklift handling of the loaded dispenser in its container.

A cardboard carton in the container is used to store fins, socket-head capscrews, and washers.



Figure 2-4. Container for Dispenser.

The container is 95 1/2 inches long, 23 1/8 inches wide, and 24 15/16 inches high. The stacking height is 24 7/8 inches. The empty container weighs about 350 pounds; with a Mk 15 Mod 0 cluster bomb, the total weight is approximately 1100 pounds.

2-5.2 FUZE AND ARMING VANE.  
The outer container for the M907 fuze and arming vane (T5E2) is a disposable wooden crate. Each fuze is

individually packed in styrofoam and pressure-sealed in a barrier bag. Twelve fuzes and arming vanes are then packed and shipped in the wooden crate.

## 2-6 HANDLING EQUIPMENT

No special handling equipment is required for the Cluster Bomb Mk 15 Mod 0. A hoisting lug is furnished with the dispenser so that standard hoists can be used. When transported in the container, two pockets on the bottom of the container can be used in handling by forklift. When the cluster bomb is moved from one area to another, Aero 12B or Aero 12C bomb skids with soft-shell adapter slings can be used. The Mk 7 bomb trailer can be used also to move the weapon to land-based aircraft.

Chapter 3

FUNCTIONAL DESCRIPTION

The Mk 15 Mod 0 cluster bomb is released from the aircraft in the same manner as any standard general-purpose bomb. Upon release, the suspension bands open automatically and drop free of the dispenser body. Simultaneously, the arming wire is withdrawn, initiating the fuze time delay cycle.

When the fuze functions, the fuze booster is ignited and the fuze and

nose locking ring are blown forward unlocking the forward end of the dispenser. Ram air forces, acting on the dispenser, force the two halves apart, hinging them about the end plate. The payload is instantaneously dispensed to disperse and saturate an elliptical area several hundred feet in diameter.

Figure 3-1 shows a sequence of case separation action.

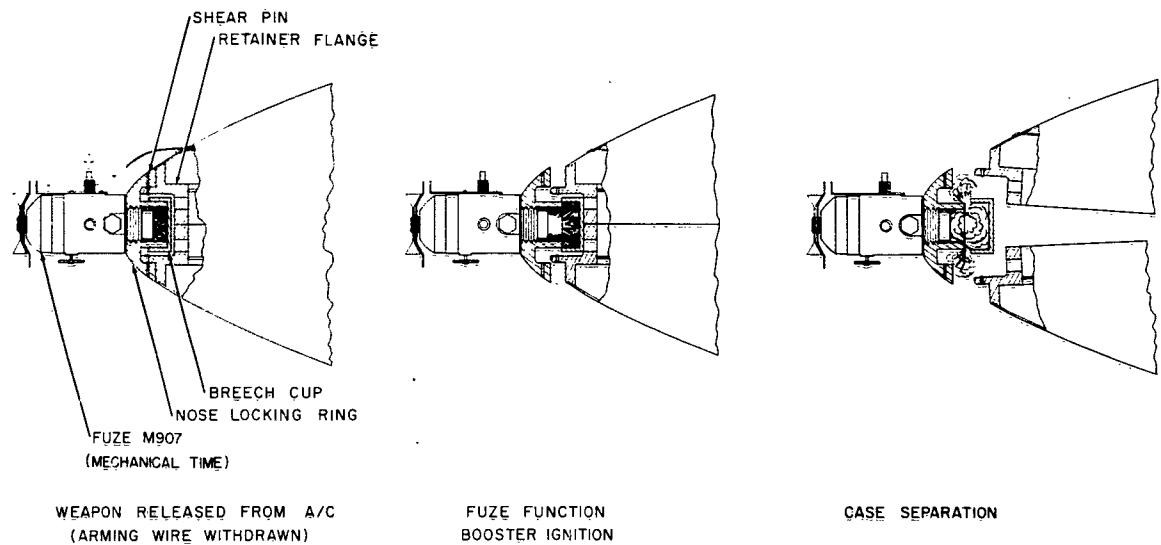

Figure 3-1. Case Separation Action.

Chapter 4

OPERATION

The Cluster Bomb Mk 15 Mod 0 is received in the Mk 320 Mod 0 Container. The fuzes and arming vanes are received in disposable wooden crates and are palletized. For decanning, a team of two men is required; for assembly, a team of two or three is required. Procedures for decanning, assembly, loading and unloading the aircraft, and disassembly are given in the following paragraphs.

4-1 DECANNING

When the container is received by the using activity the decanning is as follows:

1. Remove clamps that secure lid on metal shipping container.
2. Lift upper half (lid) of container off, figure 4-1.

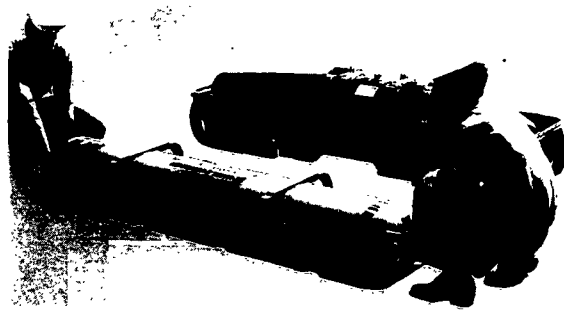

Figure 4-1. Lid Lifted From Container.

3. Release two retaining bands that hold weapon dispenser in container.

4. Place chain hoist directly over weapon dispenser and connect hoisting hook, with safety device, to hoisting lug, figure 4-2.

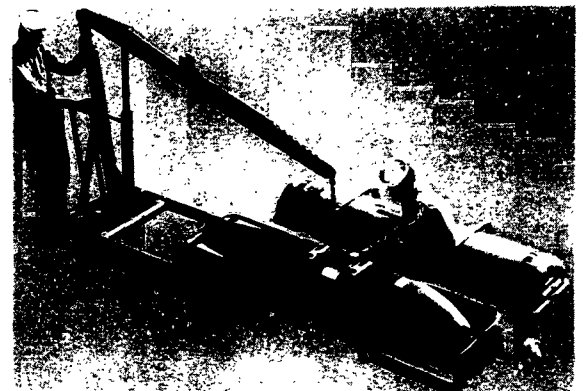

Figure 4-2. Chain Hoist Attached to Dispenser.

**CAUTION: DO NOT** use suspension lugs for handling. The suspension bands are accurately positioned to assure proper alignment when installed on the bomb rack.

5. Lift cluster bomb clear of container and place on Aero 12B or 12C bomb skid with soft-shell adapter slings, figure 4-3.

6. Remove cardboard carton from metal shipping container and unpack four fins, capscrews, and washers.

7. Remove plastic thread protectors (16) from fin attachment holes.

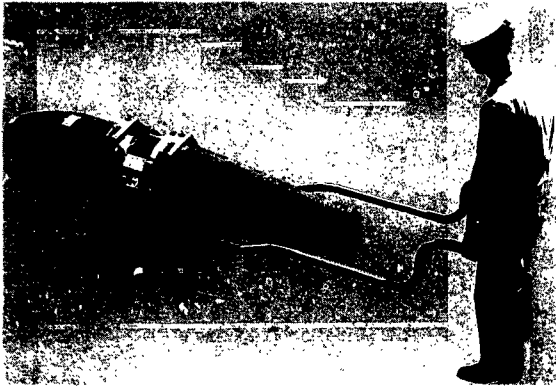

Figure 4-3. Dispenser on Aero 12B Bomb Skid  
With Soft-Shell Adapter Slings.

8. Secure fins to after end of bomb, using 1/4-inch socket-head capscrews and washers from the fin carton, figure 4-4.



Figure 4-4. Fins Attached to Dispenser.

NOTE: The perpendicular portion of the fin is toward the after end of the weapon.

9. Tighten socket-head capscrews, using hexagonal wrench.

10. Move cluster bomb to appropriate magazine for stowage.

NOTE: The payload determines the type of magazine stowage required.

11. Remove fuzes and arming vanes from wooden crate and stow in HE magazines.

12. Return metal shipping container to appropriate ammunition stocking point. Dispose of wooden crate.

#### 4-2 ASSEMBLY

When decanned components have been transported from stowage to the assembly area, proceed as follows:

1. Remove hoisting lug from dispenser.

2. Determine the arming wire attach point for the particular bomb rack on which cluster bomb is to be placed (see decals on dispenser body).

a. The small opening between the forward suspension band and the hoisting lug receptacle is used when the weapon is to be placed on bomb racks where the arming wire solenoid is located between the lug hooks.

b. The small opening between the nose and the forward suspension band is used when the weapon is to be placed on bomb racks where the arming wire solenoid is forward of the forward lug hook.

3. Remove the plastic plug from appropriate opening to be used for arming wire.

4. Punch an exit hole for arming wire, using a pencil or similar object.

5. Thread arming wire through designated opening until at least 1 foot of wire extends through the arming wire exit hole, figure 4-5.

6. Remove plastic thread protector from fuze well of bomb.



Figure 4-5. Arming Wire Inserted Through Dispenser.

7. Remove M907 fuze from fuze container.
8. Place a star washer on threaded portion of fuze.

NOTE: Do not install the fuze without at least one star washer on the threaded portion of the fuze. Additional washers may be required, as indicated in the following steps.

9. Place fuze in fuze well of nose of dispenser and screw fuze clockwise until handtight, figure 4-6.



Figure 4-6. Fuze Screwed Into Fuze Well of Dispenser.

10. Align arming wire bracket on side of fuze with arming wire exit hole within 45 degrees on either side, figure 4-7.



Figure 4-7. Arming Wire Aligned.

NOTE: This measurement can be made by sighting the arming wire bracket to determine if the bracket is between the fins on the upper half of the bomb. If the bracket extends beyond a line of the fins, remove the fuze and add an additional star washer to the threaded portion of the fuze. Continue to add star washers until the bracket lines up within 45 degrees on either side of the arming wire exit.

11. Place Arming Vane T5E2 on forward end of fuze.

NOTE: Name and part number of arming vane faces away from the weapon.

12. Turn arming vane clockwise until it is locked securely to fuze.

13. Thread arming wire through openings in fuze not used for safety wire and then through opening in arming vane plate.

14. Attach two Fahnestock clips to end of arming wire to secure it, figure 4-8.

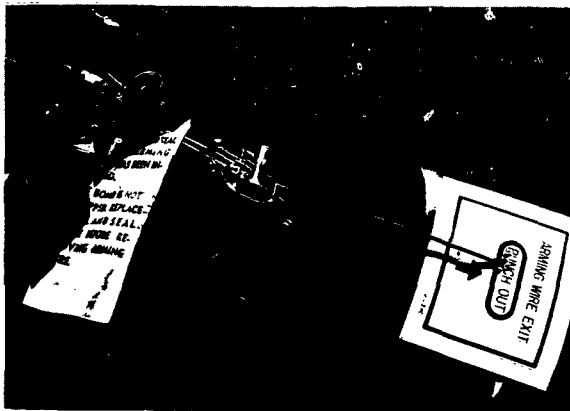

Figure 4-8. Fahnestock Clips Attached to Arming Wire.

#### WARNING

DO NOT remove the fuze safety wire at this time.

15. Set delay time of fuze as follows:

a. Unlock graduated ring dial by loosening the locking wing screw located on the fuze, opposite the safety wire.

b. Turn graduated ring dial to maximum time stop (92 seconds).

c. Turn graduated ring dial until correct time is aligned with white mark on body of fuze.

NOTE: When turning ring dial to desired time setting, DO NOT pass white mark or reverse motion of ring dial as this will cause errors in fuze functioning time. Repeat step b if necessary.

d. Relock graduated ring dial by tightening locking wing screw clockwise until handtight.

16. Move cluster bomb to aircraft.

#### 4-3 AIRCRAFT LOADING

To attach the weapon to the bomb rack of the aircraft, proceed as follows:

1. Wheel bomb skid with bomb directly under aircraft bomb rack with fuze toward nose of aircraft.

2. Lift weapon to bomb rack.

NOTE: For land-based aircraft, Mk 7 Mod 1 bomb trailer may be used; for others, Mk 8 Mod 0 or Mk 14 Mod 0 hoist with appropriate slings may be used.

3. Raise weapon to bomb rack until suspension lugs are secure to bomb rack.

4. Tighten sway braces, figure 4-9.

5. Attach arming wire in arming wire solenoid of bomb rack. Take up slack in wire. Slip clips snugly against vane. Cut off excess arming wire, allowing the end to extend 2 to 3 inches past the vane and clips. The end of the wire must be free of kinks and burrs.



Figure 4-9. Sway Braces Tightened on Bomb.

6. Remove lever locking pin assembly, figure 4-10, from each suspension band by depressing levers, using 15-inch pinch bar or large screwdriver.

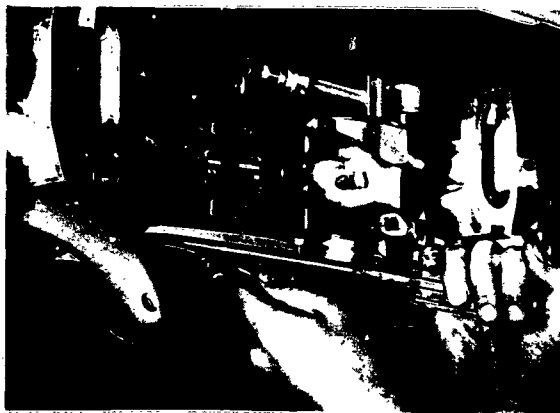

Figure 4-10. Lever Locking Pin Assembly Removed.

7. Store lever locking pin assembly, in the event of return of the bomb.

8. Pull safety wire from fuze, figure 4-11.

9. Make the following checks of assembly before takeoff of aircraft.

a. Arming wire properly installed in fuze.

b. Arming vane securely attached to fuze.

c. Recheck time delay setting.

d. Delay timing graduated ring dial securely locked in CORRECT position.

NOTE: DO NOT move ring dial. If moved comply with paragraph 4-2 assembly procedures (step 15).

e. Arming wire properly connected to arming wire solenoid.

f. Levers on suspension bands bearing on bomb rack hooks.

g. Lever locking pin assembly removed.

h. Safety wire removed from fuze.



Figure 4-11. Safety Wire Removed.

#### 4-4 UNLOADING CLUSTER BOMB MK 15 MOD 0 FROM AIRCRAFT

If the aircraft returns with the bomb attached, proceed as follows:

1. Insert safety wire in fuze.

2. Insert lever locking pin assembly in each suspension band.

Revision 1

3. Disconnect arming wire from bomb rack arming wire solenoid.

4. Using Mk 8 or Mk 14 bomb hoist with appropriate slings, lower cluster bomb to Aero 12B or 12C bomb skid that has soft-shell adapter slings.

5. Transport unit to assembly area for disassembly or to ready-service stowage.

#### 4-5 DISASSEMBLY

If a returned cluster bomb is to be stowed unassembled, proceed as follows:

1. Remove Fahnstock clips from arming wire.

2. Remove arming wire from fuze.

3. Replace the plastic plug in arming wire opening.

4. Remove arming vane from fuze by quarter turn counterclockwise.

5. Unscrew fuze from bomb and return to fuze container.

6. Place plastic thread protector in fuze well.

7. Place hoisting lug in opening between the two suspension bands.

8. Move weapon, fuze, and arming vane to designated magazine stowage.

#### NEGATIVE NUMBERS OF ILLUSTRATIONS

Frontispiece. L090168	Figure 4-4. L089813
Figure 2-1. L084475	Figure 4-5. L089812
Figure 2-2. L089809	Figure 4-6. L089808
Figure 2-3. L089801	Figure 4-7. L089804
Figure 2-4. L089811	Figure 4-8. L089815
Figure 3-1. L084681	Figure 4-9. L089802
Figure 4-1. L089805	Figure 4-10. L089806
Figure 4-2. L089814	Figure 4-11. L089803
Figure 4-3. L089810	

## INITIAL DISTRIBUTION

### 22 Chief, Bureau of Naval Weapons

CS-3 (1)	RM-377 (2)
DLI-31 (2)	RM-379 (1)
PID-24 (1)	RMMO (1)
PWS-424 (1)	RMMO-2 (1)
RAAD-13 (1)	RMMO-4 (2)
RAAV-5 (1)	RMMO-43 (2)
RM-12 (1)	RSWI-2 (1)
RM-3 (1)	RSWI-5 (1)
RM-33 (1)	RSWI-6 (1)

### 2 Chief of Naval Operations

OP-55 (1)  
OP-72 (1)

### 1 Air Development Squadron 5 (Conventional Weapons Project Officer)

### 1 Marine Air Weapons Training Unit, Marine Corps Air Station, Cherry Point (Maj. Gerlock)

### 2 Marine Corps Air Station, El Toro

Marine Air Weapons Training Unit (1)  
3d Marine Aircraft Wing (1)

### 2 Marine Corps Schools, Quantico (Marine Corps Landing Force Development Center)

### 2 Naval Air Development Center, Johnsville

Code SI (1)  
Code WR-2 (1)

### 1 Naval Air Engineering Facility (SI), Naval Air Engineering Center, Philadelphia

### 1 Naval Air Test Center, Patuxent River

### 2 Naval Ordnance Laboratory, White Oak

Code DM (1)  
Code XWF (1)

### 1 Naval Training Device Center, Port Washington (Librarian)

### 4 Naval Weapons Laboratory, Dahlgren

Code KBB (1)  
Code KE (1)  
Code T (1)  
Code WX (1)

### 1 Operational Test and Evaluation Force (Air Warfare Division, Light Attack Assistant)

### 1 Tactical Air Control Squadron 11 (Operations Officer, Maj. E. E. Smith)

### 2 Air Proving Ground Center, Eglin Air Force Base

CAG-DR (1)  
PGBAP-1 (1)

### 1 Air University Library, Maxwell Air Force Base

### 1 1st Combat Applications Group, Eglin Air Force Base

### 1 Detachment 4, Weapons Division, Eglin Air Force Base