

NOTS TP 2244

ZUNI

**5.0-inch high-performance
folding-fin aircraft rocket**

NOTS TP 2244

first revision

A HANDBOOK FOR THE ORDNANCE MAN

NOTS Technical Publication 2244
First Revision

Published by Technical Information Department
Collation Cover, 18 leaves
First printing 500 copies
Security classification UNCLASSIFIED

U N C L A S S I F I E D

U. S. NAVAL ORDNANCE TEST STATION

W. W. HOLLISTER, CAPT., USN
Commander

WM. B. MCLEAN, PH.D.
Technical Director

ZUNI

5.0-INCH HIGH-PERFORMANCE FOLDING-FIN AIRCRAFT ROCKET

FIRST REVISION

A Handbook for the Ordnanceman

NOTS TP 2244

First Revision

China Lake, California

29 September 1959

U N C L A S S I F I E D

CONTENTS

Foreword	iii
Introduction	1
Major Components of the ZUNI Weapon System	1
5.0-Inch Rocket Motor Mk 16 Mod 1	3
Heads	4
Fuzes	6
LAU-10/A Launcher	7
Frangible Fairings	7
Ignition Principles	8
Description and Operation of Launcher	9
Preparing Aircraft for Launcher Installation	13
Checking Bomb Rack	14
Preparing Launcher for Bomb-Rack Attachment	14
Attaching Launcher to the Bomb Rack	16
Attaching Heads, Fuzes, and Fairings	17
Arming Check	19
Removing Launcher from Aircraft	19
Loading Rocket Motor Into Launcher	20
Unloading Rocket Motor From Launcher	22
Maintenance and Storage	23
Motor	23
Heads	25
Fuzes	26
LAU-10/A Launcher	26
Frangible Fairings	27
Maintenance Test of Launcher	27
Detent Re-Cocking Procedure	29
Safety Precautions	30
General Safety Precautions	30
Launcher Loading and Unloading Precautions	31
Special Safety Precautions for Mk 26 Mod 0 Head (Illuminating)	32

FOREWORD

As the 5.0-inch folding-fin aircraft rocket (ZUNI) is being readied for the fleet, a matter-of-fact guide is needed for the men who will prepare the system for use, who will teach and supervise the handling of the weapon, and who will maintain the system in fleet readiness.

This publication, NOTS TP 2244 (Rev. 1), supersedes NOTS TP 2244, dated 26 May 1959, and is issued in this form for distribution to activities having immediate need for the information it contains. Users should remember that components and procedures described in this revised publication are subject to further changes. A Confidential Bureau of Ordnance Pamphlet on ZUNI will be issued in the near future.

K. H. BOOTY
Head, Engineering Department

Released under
the authority of:
WM. B. MCLEAN
Technical Director

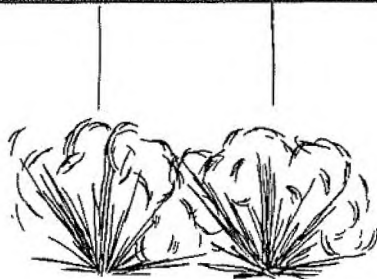
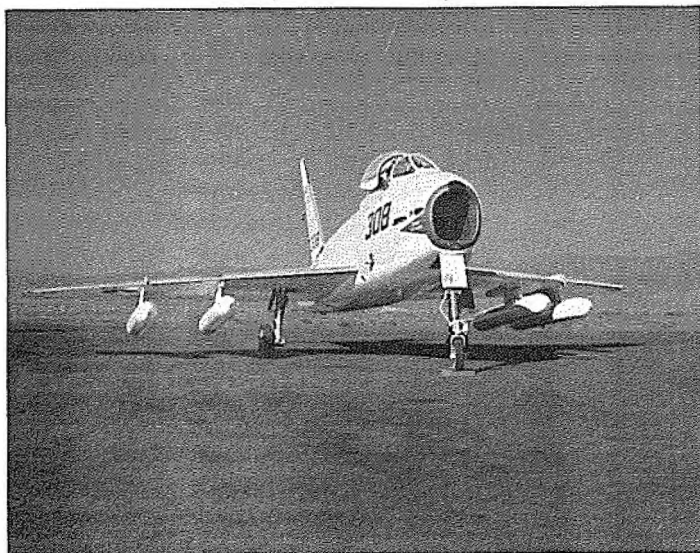
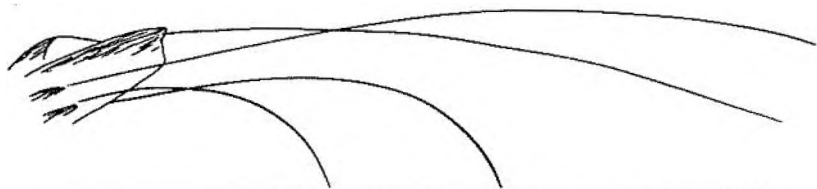

INTRODUCTION

The ZUNI weapon system, which consists of supersonic unguided 5.0-inch rockets in four-round package launchers, is designed for use on jet fighter aircraft and replaces the old work horse, the 5.0-inch HVAR.

The ZUNI rocket is designed for both air-to-ground and air-to-air attack. A reliable high-performance motor with an internal-burning solid-propellant grain gives ZUNI high velocity and short time to target. Blast-operated radially folding fins stabilize the rocket's flight for minimum dispersion. An array of interchangeable warheads provides effectiveness in a wide variety of tactical situations. An inert-loaded head is also available for practice exercises. Matching the versatility in payload, the ZUNI fuze gives an option of proximity, contact, or time-delay detonation.

The ZUNI was developed for the Bureau of Ordnance at the U. S. Naval Ordnance Test Station, China Lake, California.

MAJOR COMPONENTS OF THE ZUNI WEAPON SYSTEM

The ZUNI rocket (Figure 1) is launched from the LAU-10/A launcher. The launcher is a reusable package unit for shipping (without heads), stow-

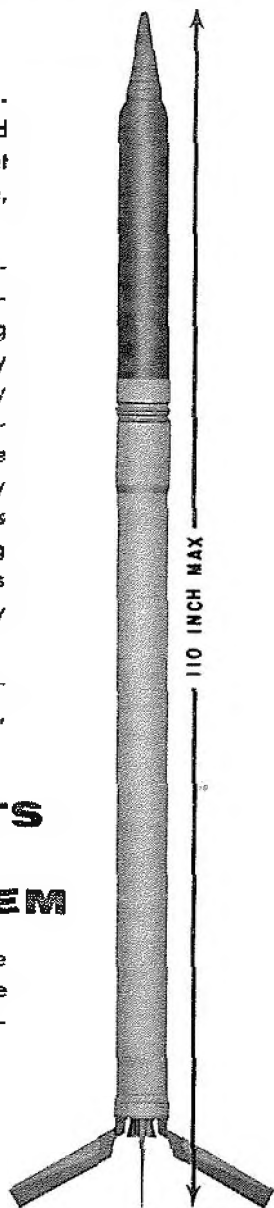

FIG. 1. Over-all View of the ZUNI Rocket (Mk 32 Head and M 414 Proximity Fuze).

ing, and firing four 5.0-inch ZUNI rockets (Figure 2). When the LAU-10/A is used as a launcher, frangible fairings are secured over the ends of the launcher. These fairings are made of a material that shatters readily from rocket impact and rocket blast without damage to the aircraft. Six frangible fairings in their container are shown in Figure 3. Launcher tools for assembly of the ZUNI weapon are attached to the pallet load at the Naval Ammunition Depot.

The major components of the ZUNI weapon system are as follows:

- 5.0-Inch Rocket Motor Mk 16 Mod 1
- 5.0-Inch Rocket Head Mk 32 Mod 0 (ATAP)
- 5.0-Inch Rocket Head Mk 24 Mod 0 (GP)
- 5.0-Inch Rocket Head Mk 26 Mod 0 (Illuminating)
- Fuze Mk 188 Mod 0 (PD)
- Fuze M 414 (Proximity)
- Fuze Mk 191 Mod 0 (BD)
- LAU-10/A Launcher
- Frangible Fairings

FIG. 2. LAU- 10/A Launcher Used as Shipping Container.

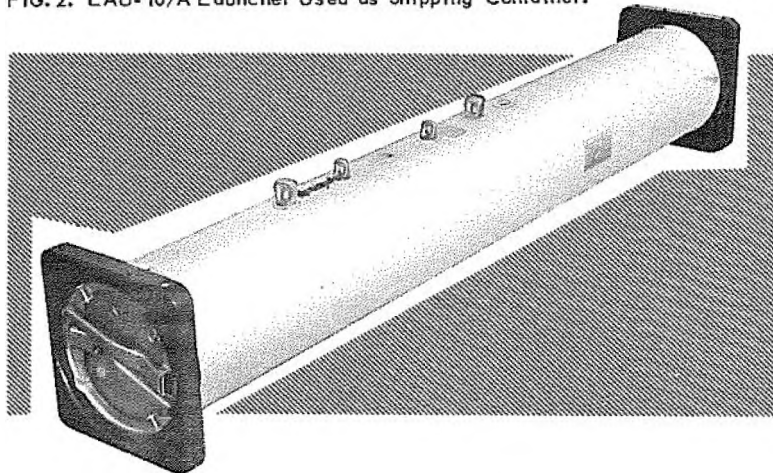

5.0-inch rocket motor mk 16 mod 1

The motors are shipped completely assembled in the LAU-10/A rocket launcher or in individual shipping containers. A thread protector is screwed into the head end of the motor when it is shipped individually. This thread protector should not be removed until just before the rocket head is attached. The contact band at the forward end of the motor is covered by a shielding band that must be left in place until just before the contact band on the motor enters the launcher during loading. The shielding band seats in the motor-defent groove and covers the ignition contact band, thereby shorting out the ignition circuit and providing protection against radio-frequency energy.

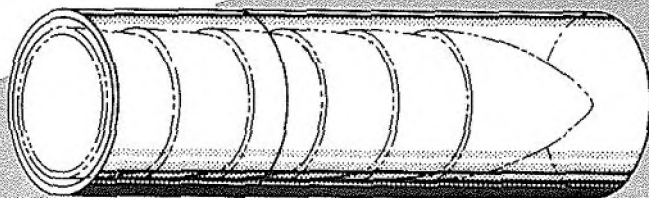

FIG. 3. Frangible Fairings in Container.

Nozzle Assembly

The nozzle assembly consists of a steel nozzle, four aluminum-alloy fins, and steel fin-locking pawls. The fins are uniformly tapered in thickness from the pivot to the tip and are folded within the diameter of the round. They open to flight position after emerging from the launcher.

Grain

The ZUNI has an internal-burning, double-base, solid-propellant grain.

Ballistic Rod

A ballistic rod installed through the center of the star-shaped grain perforation in the forward section smoothes the burning, prevents flameout, and suppresses flash.

Igniter

The igniter, located at the head end of the motor, is charged with FFFG black powder and coated magnesium powder. Two Mk 1 squibs connected in parallel initiate the igniter.

heads

5.0-Inch Rocket Head Mk 32 Mod 0 (ATAP)

The Mk 32 Mod 0 rocket head, antitank, antipersonnel (ATAP) is shown in Figure 4. Used in ZUNI, this head with a point-detonating (PD) fuze (Mk 188 Mod 0) effects shaped-charge action. *Thus, it is highly effective against heavy targets such as tanks or bunkers.* The Mk 32 head has a cavity liner to prevent exposing the explosive when fuzes are changed. For fragmentation action against aircraft or personnel, a proximity fuze (M 414) may be attached to the head.

5.0-Inch Rocket Head Mk 24 Mod 0 (GP)

The Mk 24 general-purpose (GP) head is shown in Figure 5. This head may be fuzed for contact, proximity, or delayed detonation. The Mk 191 Mod 0 (BD) fuze is permanently assembled in the base of the Mk 24 Head. When used with a steel nose plug, the Mk 24 is a delayed-action warhead. The steel nose plug enables it to penetrate heavy targets, such as concrete bunkers and ships, and to detonate inside the target. The M 414 proximity fuze or the Mk 188 point-detonating fuze also may be used in this head with effectiveness. (See WARNING on page 32.)

A metal fuze-cavity liner is used at the nose end. It is screwed and cemented into the head so that it is permanently in place. This liner prevents exposure of the high explosive when a nose fuze is being attached or detached.

5.0-Inch Rocket Head Mk 26 Mod 0 (Illuminating)

The Mk 26 Mod 0 head (Figure 6) contains a fuze, flare candle, main suspension parachute and its pilot chute, a delay-action mechanism, and a drag parachute. This head enables a pilot to illuminate his target and destroy it with an explosive-loaded ZUNI rocket in a single pass, thus preserving an element of surprise.

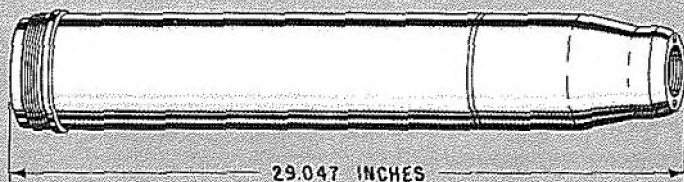

FIG. 4. 5.0-Inch Rocket Head Mk 32 Mod 0 (ATAP).



FIG. 5. 5.0-Inch Rocket Head Mk 24 Mod 0 (GP).

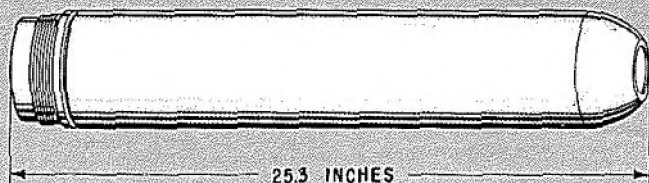

FIG. 6. 5.0-Inch Rocket Head Mk 26 Mod 0 (Illuminating).

fuzes

Three fuzes are available for use with ZUNI. A fuze may be selected for point detonating (PD), base detonating (BD), or proximity detonating.

Fuze Mk 188 Mod 0 (PD)

The Mk 188 Mod 0 (PD) fuze (Figure 7) may be attached to the nose of the 5.0-Inch Rocket Heads Mk 32 Mod 0 and Mk 24 Mod 0. If a rocket is accidentally fired on a carrier, the fuze will not arm within the length of the carrier; therefore, a ZUNI with this fuze is carrier-safe.

Fuze M 414 (Proximity)

The M 414 fuze (Figure 8) may be used in the 5.0-Inch Rocket Heads Mk 32 Mod 0, Mk 24 Mod 0, and Mk 41 Mod 0. This fuze will detonate the warhead in air-to-air application upon proximity approach to target aircraft. In air-to-ground application the warhead is detonated above ordinary terrain at appropriate approach angles, thus achieving maximum effectiveness.

When the rocket is fired as one of a salvo, the fuze will not function on another rocket in flight. This fuze is also carrier-safe.

Fuze Mk 191 Mod 0 (BD)

The Mk 191 Mod 0 base-detonating fuze (Figure 9) is an electro-mechanical, acceleration-arming, impact fuze installed in the base

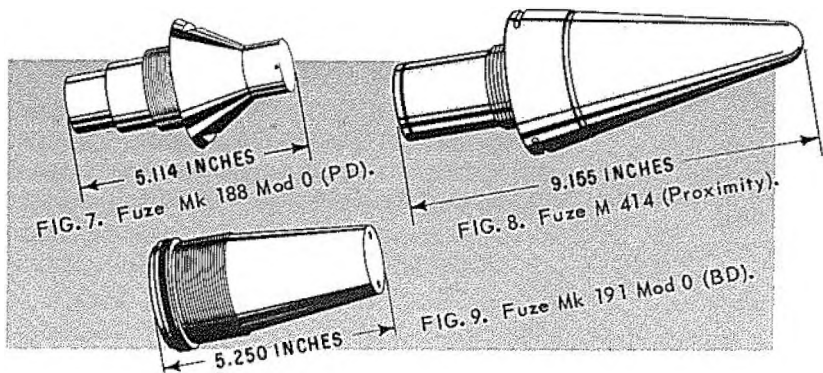

of the 5.0-Inch Rocket Head Mk 24 Mod 0 at the time the head is loaded with high explosive and requires no attention by fleet personnel. It, too, is carrier-safe.

lau-10/a launcher

The LAU-10/A launcher is a dual-purpose unit for shipping the rocket motors and for launching the ZUNI rockets. When attached to the aircraft ready for flight, it weighs approximately 105 pounds empty and 533 pounds loaded, ready to fire four ZUNI rockets.

FIG. 10. Launcher Completely Assembled With Fairings in Place.

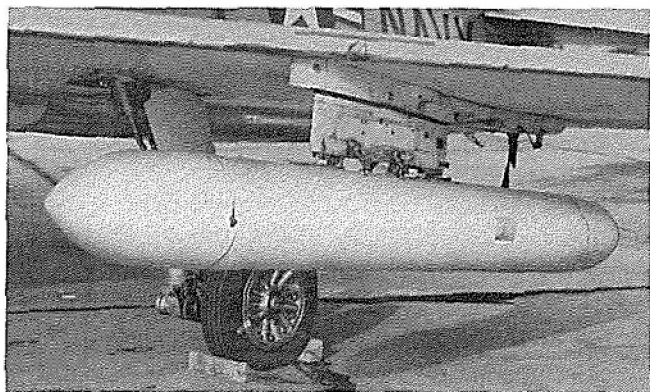

frangible fairings

The frangible fairings are made of treated paper and will shatter readily from rocket impact or rocket blast. The fairing has a metal band at the base equipped with lugs and a leaf-spring for attaching it to the launcher center section. The lugs engage grooves in the center-section retainer rings and, as the fairing is rotated clockwise, the spring clip drops into position to lock the fairing securely in place. The fairing fits flush with the outside surface of the center section of the launcher to form an aerodynamically smooth joint. The launcher with completely assembled rockets and frangible fairings in place is shown mounted on the aircraft in Figure 10.

IGNITION PRINCIPLES

When the switch in the aircraft firing circuit is closed, the electrical current passes from the aircraft firing circuitry through the firing contact, the intervalometer in the launcher, the contact band at the forward end of the motor, and from there through the lead wire to the squib in the igniter. The electrical current then passes back via the squib ground wire to the igniter and rocket body (which is grounded through the launcher detent to the launcher body and suspension lugs) and back to the airframe ground. The firing circuit diagram is shown in Figure 11.

A minimum firing current per round of 1.5 amperes for 10 milliseconds is required; the recommended firing current per round is 3.0 amperes. If the current drops below 1.5 amperes, increases in the delay of ignition may be expected. The loaded igniter has a resistance of 0.5 to 1.5 ohms.

Current entering the squib heats the bridge wire, setting off the squib primer mixture that, in turn, ignites the igniter charge. Pressure within the igniter unseats a blowout plug, permitting the burning charge to ignite the propellant grain. The whole process of ignition requires about 0.05 second. Pressure of the hot propellant gases from the burning grain bursts the nozzle seal and provides the thrust to propel the rocket.

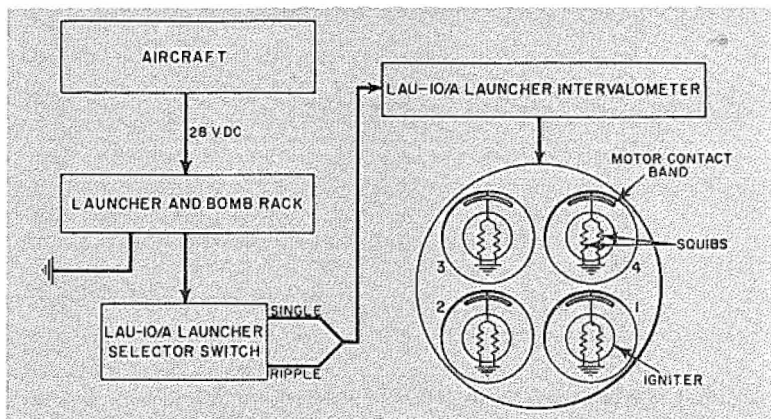

FIG. 11. Firing Circuit Diagram.

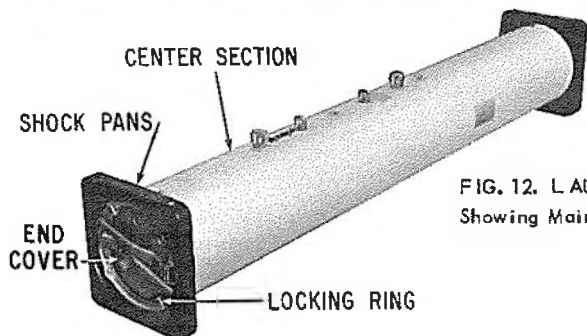

FIG. 12. LAU-10/A Launcher
Showing Main Parts.

DESCRIPTION AND OPERATION OF LAUNCHER

When used as a shipping package, the LAU-10/A launcher (Figure 12) consists of the launcher center section (with four 5.0-inch ZUNI rocket motors), the shock pans, end covers, and lock rings.

In shipping configuration, the launcher is 98 inches long, has a 16- by 16.5-inch cross section, and weighs 140 pounds empty and 380 pounds when loaded with motors only. A second package, the fairing container (Figure 3), has six streamlined frangible fairings, enough to equip three launchers. A third package contains the detent-lift tool (Figure 13) and the ignition post (Figure 14). This equipment (one set for each launcher) is attached to the pallet load (in a separate container) at the Naval Ammunition Depot.

FIG. 13. Detent-Lift Tool.

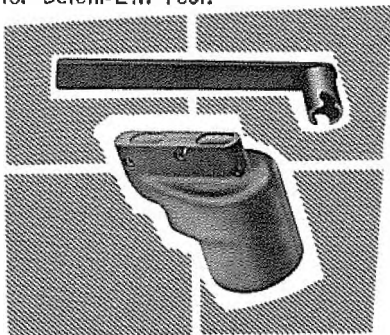

FIG. 14. Ignition Post.

The LAU-10/A launcher is a white-painted container with multiple-suspension lugs (Figure 15) compatible with most Navy and Air Force tandem-suspension 14- and 30-inch bomb racks, and the British single-suspension bomb racks.

Operating principles used in the LAU-10/A launcher have been proved in other armament. The rockets may be single- or ripple-fired. The firing pulse is distributed to the individual rockets by an intervalometer that is mounted in the launcher's forward retainer ring. The ignited rockets override the sear detent latches and are released. The frangible fairings shatter readily upon rocket impact or rocket blast.

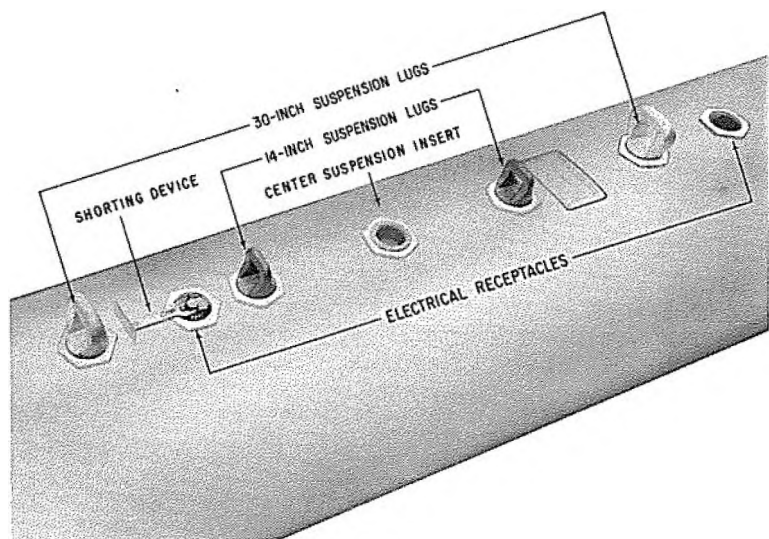

FIG. 15. Section of Launcher Showing Suspension Lugs.

Electrical

Electrical power for the rocket ignition system is supplied to the launcher by the 28-volt-DC armament circuit of the aircraft. Electrical connection between the aircraft and the launcher is made through either of two parallel five-pin receptacles located in the vicinity of the lugs in the center section of the launcher (Figure 12). As a safety requirement, each receptacle is fitted with a shorting device (Figure 16) that shorts the aircraft armament circuit, preventing inadvertent operation of the intervalometer. Pins A and B of the receptacles are positive connections to the aircraft. Pin E is the negative connection and is grounded to the launcher-hanger beam that, in turn, is grounded to the aircraft through the suspension lugs. (Refer to Figure 11 for a schematic of the firing circuit.)

A selector switch is located in the after retainer ring of the launcher for preflight selection of either ripple or single firing of the rockets

FIG. 16. Shorting Device.

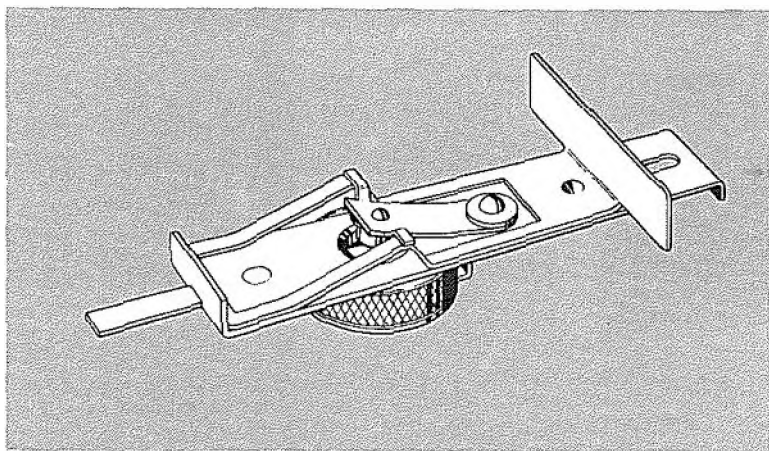

through the intervalometer (Figure 17). The intervalometer, located in the center-section forward retainer ring, is so designed that when single-fire is employed, the intervalometer fires one rocket on each ignition pulse from the aircraft. When ripple-fire is employed, the intervalometer converts the ignition pulse into a ripple pulse and fires all rockets at approximately 100-millisecond intervals. It is necessary to keep the firing circuit energized continuously for 0.5 second to ensure a complete fire-out on ripple firing. When the intervalometer has made a complete four-round firing cycle, it automatically homes on the original starting point (ZERO) and will not recycle without first de-energizing the circuit, then re-energizing it. The intervalometer contacts are so arranged that when the intervalometer is at rest or stopped, the rocket squib leads are shorted.

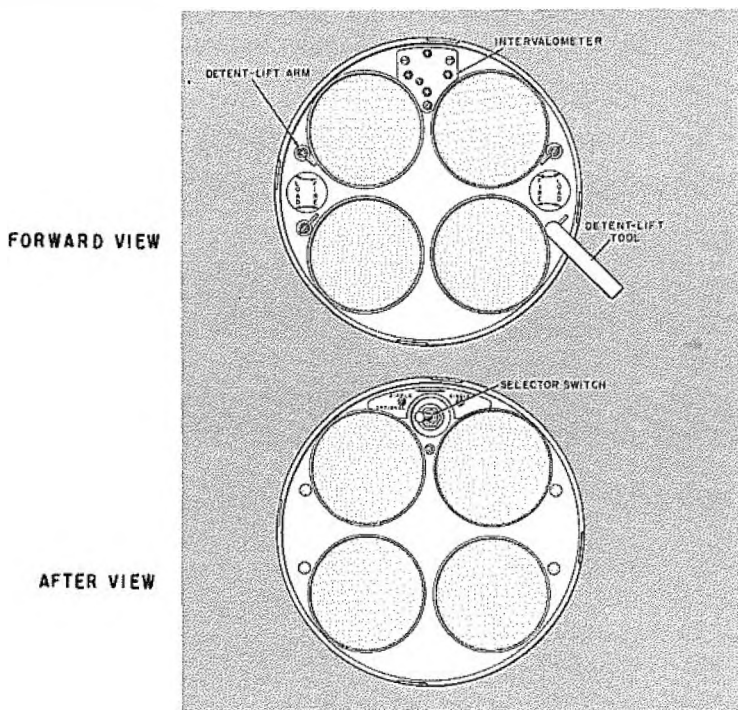

FIG. 17. Forward and After View of the Launcher.

In addition to the selector switch located in the after retainer ring of the launcher, some aircraft have a selector switch in the cockpit. In aircraft so equipped, the pilot has an in-flight option of either ripple or single firing, provided the selector switch in the launcher is in the RIPPLE-OPTIONAL position before takeoff. In aircraft equipped with the selector switch, there are two positive leads to the electrical receptacles of the launcher, one to Pin A and the other to Pin B. In aircraft not so equipped, the method of firing is restricted to the preflight setting of the launcher-selector switch. In this case, there is only one positive lead, which is connected to Pin A.

Electrical connection to the rocket motor is completed through a contact post mounted on a bracket attached to the detent sub-assembly and then to a contact band on the rocket motor. The contact post and band form the positive connection, and the negative connection is through the rocket-motor tube and detent.

Center Section

The launcher center section contains the four launcher tubes (each equipped with a sear detent latch), the electrical ignition system, using a selector switch and an intervalometer, and the suspension lugs.

preparing aircraft for launcher installation

Testing Aircraft Armament Circuit

1. Proceed in accordance with current instructions to check firing circuit for voltage.
2. Increase engine speed until cockpit voltmeter indicates full system voltage—28 volts.
3. Connect an ammeter (0 to 10-ampere range) directly to the HYAR wing electrical receptacle.

NOTE: The greatest single cause of firing failure is the lack of electrical continuity between the aircraft and the rocket.

4. Energize the station where the ammeter is connected and note the reading. The ammeter should register a minimum of 3.0 amperes. A pulse less than 3.0 amperes may not fire all four rockets.
5. Place armament switches in OFF position.

checking bomb rack

WARNING



The LAU-10/A launcher shall not be suspended from a bomb rack that does not have separate ignition and jettisoning circuits.

1. Prepare the rack on the aircraft for accepting the suspension lugs in accordance with instructions contained in the aircraft operating instructions.
2. For racks without a striker arm, remove the ignition cable from the rack and connect it to the nearest receptacle on the launcher. For Aero 20A racks and all other heavy-duty bomb racks, disconnect the receptacle inside the access panel before attaching the cable to the launcher.

preparing launcher for bomb-rack attachment

1. When on Aero 15B combination rack or any other rack with a forward rocket-firing position is used, remove the shorting device from the forward receptacle. Save this shorting device for reinstallation when the launcher is taken from the aircraft.

2. Make sure the shorting device in the after receptacle is in the SAFE position until the aircraft is ready for takeoff, at which time move the shorting device to the ARM position.
3. Install the ignition post in the forward receptacle.
4. For racks using the rear contact receptacle, such as the Aero 20A, remove and save shorting device from the after receptacle, and use the forward shorting device as outlined in Steps 1 and 2.

WARNING

Make sure the shorting device being used is in SAFE position until aircraft is ready for takeoff.

5. For racks with only 14-inch suspension (Aero 15 series), remove the 30-inch suspension lugs (BuAer Dwg. 54A46C358) from the LAU-10/A launcher (refer to Figure 15).
6. For all other racks, remove the 14-inch suspension lugs (BuOrd Dwg. 1252628) (refer to Figure 15).
7. For single-lug suspension, remove both the 14- and 30-inch suspension lugs, and install the British suspension lugs (not provided) in the center position.

NOTE: When the launcher is to be used on a bomb rack with both 14-inch and 30-inch suspension hooks, the 30-inch suspension shall be used.

8. Adjust suspension lugs to the vertical dimension shown on the decal opposite the lugs. Dimension is to be from the inside top of the lug to the face of the threaded insert. If lugs are not 90 degrees to the horizontal centerline of the launcher, back off enough to align.

FIG. 18. Forward End of Launcher With Handles Extended for Manual Handling.

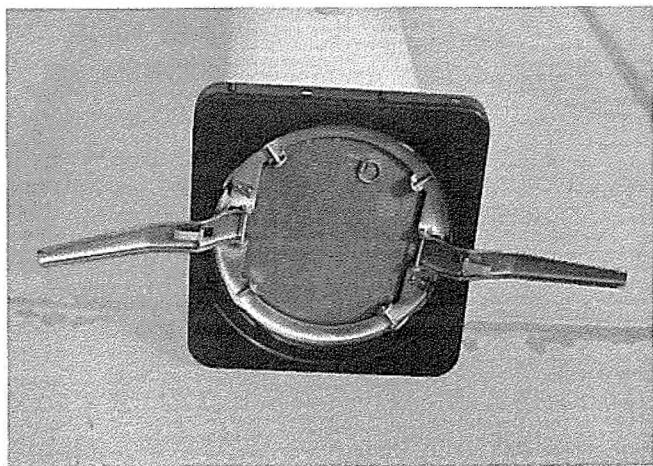

attaching launcher to the bomb rack

1. Swing locking-ring handles outward until the latches engage the shock pans (Figure 18). This step provides a means for lifting the launcher to the bomb rack.
2. Using the four handles, lift the launcher assembly and place it in the bomb rack and lock the suspension-lug hooks.
3. Position the bomb-rack sway braces to support the launcher rigidly in accordance with aircraft operating instructions.

attaching heads, fuzes, and fairings

1. Disengage the locking-ring handles from the shock pan.
2. Break or cut the lockwires holding the locking rings to the shock pans.
3. Rotate the locking rings, with handles, in a counterclockwise direction until the pins are disengaged from slots in the shock pans and remove the locking rings.
4. Remove the front and rear covers.
5. Lift the spring latch on the shock pans, rotate the shock pans counterclockwise as far as possible, and pull them away from the center section of the launcher. Shock pans, covers, and locking rings should be stowed in a suitable, convenient place for reuse.

NOTE: Refer to the Notes in MAINTENANCE AND STORAGE section and to SPECIAL PRECAUTIONS on handling of the Mk 26 Mod 0 (illuminating) head.

6. Screw the rocket heads into the rocket motor and tighten securely with a chain or spanner wrench to a torque of approximately 100 foot-pounds. The rocket stop in the after end of the launcher prevents the motor from turning while the heads are being screwed into place.
7. Attach the fuze to the head, using a spanner wrench and applying 30-40 foot-pound torque. (Figure 19 shows rockets in the LAU-10/A launcher.)

8. Set the selector switch on the launcher to *RIPPLE-OPTIONAL* or *SINGLE* position (Figure 17) as indicated by the type of aircraft or mission.
9. Remove the frangible fairings from the container.
10. To attach the fairing to each end of the launcher, align the arrow on the fairing with the arrow on the launcher marked *UN-LOCK*.
11. Push the fairing onto the center section of the launcher until it is seated against the retainer ring.
12. Rotate the fairing clockwise until the spring latch "clicks" into the locked position. The red arrow on the fairing should align with the red arrow on the launcher marked *LOCK*.

FIG. 19. Rockets Shown in LAU-10/A Launcher.

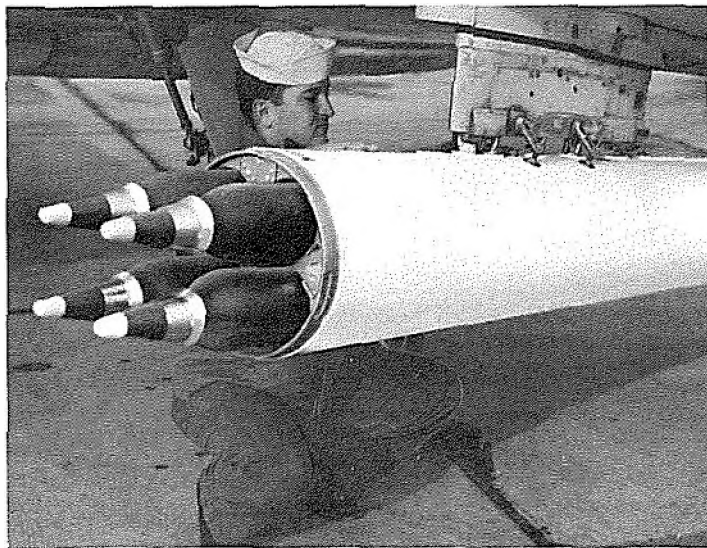

arming check

WARNING



Check bomb-rack current at regular and frequent intervals.

1. Perform standard arming stray-voltage check in accordance with existing instructions.
2. Complete the electrical connection to the launcher rack by dropping the striker arm or attaching the HVAR cable inside the bomb rack, depending on the type of rack being used.
3. Just before takeoff, place the shorting device in the ARM position.

removing launcher from aircraft

1. Place the shorting device on the launcher in the SAFE position immediately after returning from the flight.
2. Remove fairings.
3. Remove the rocket heads and fuzes and return them to the appropriate magazine storage.
4. Replace the shock pans, covers, and locking rings.
5. Disconnect the launcher from the aircraft and return the launcher to the magazine storage.

loading rocket motor into launcher

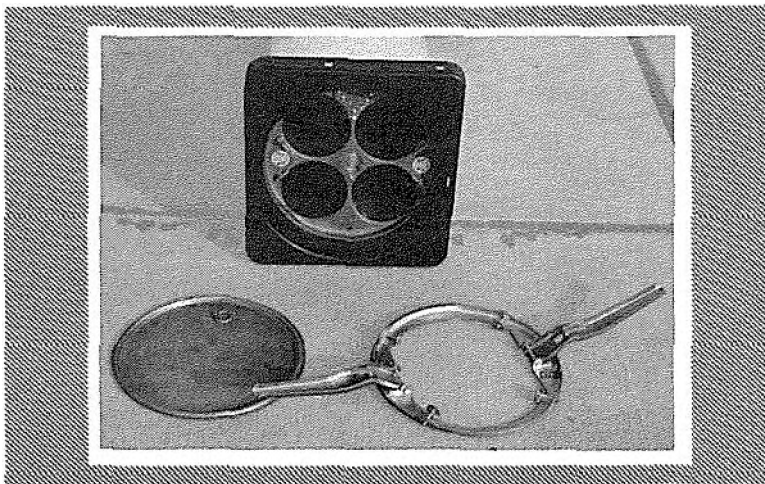

FIG. 20. Forward End of Launcher With Locking Ring and Cover Removed.

To prepare the launcher for loading with four ZUNI motors, it is necessary to remove only the forward locking ring and cover (Figure 20). With the launcher in the horizontal position, proceed as follows:

1. Check the shorting devices for SAFE positions.
2. Swing the handles out, but do not engage the handle latches with the shock pan.
3. Use the handles to turn the locking ring in a counterclockwise direction to disengage and remove the locking ring from the shock pan.
4. Using the detent-lift tool, rotate all detent-lift arms to the LOAD position (Figure 21).

WARNING

To prevent accidental ignition by electromagnetic or electrostatic energy, the shielding band must be left in place until just before the contact band enters the launcher.

5. Insert the after end of the rocket motor into the forward end of the launcher and push slowly. Remove the shielding band from the motor contact band. Continue to push slowly until the nozzle plate of the rocket motor comes into contact with the after stop in the launcher tube.
6. Using the detent-lift tool, rotate the detent-lift arm to the FIRE position (Figure 21).

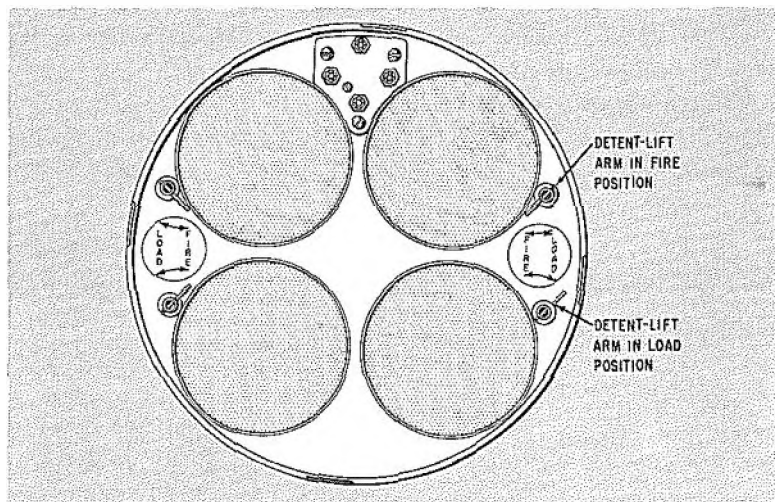

FIG. 21. Detent-Lift Arm Showing LOAD and FIRE Positions.

7. Pull or push the motor forward until the detent drops into the detent groove. An audible "click" indicates positive engagement of the detent with the detent groove.
8. Repeat the above procedure until all four motors are loaded into the launcher.

WARNING

Firing circuit continuity checks with rocket motors installed in the launcher should be made only by a Naval Ammunition Depot and should be made in strict conformance with the specified procedure using equipment designed specifically for that purpose.

9. Install the cover.
10. Install the locking ring by engaging the locking pins in the slots in the shock pan, and by the use of the handles, rotate clockwise until the pins bottom at the end of the slots.
11. Fold the handles in and lock them in place with the spring clips provided for that purpose.

unloading rocket motor from launcher

WARNING

Comply with safety precautions pertaining to launcher loading and unloading.

In the event it is necessary or desirable to remove the rocket motors from the launcher, proceed as follows:

1. Rotate the detent-lift arm to the LOAD position.
2. Pull or push the motor forward until the contact band is clear of the forward end of the launcher.
3. Install the shielding band over the contact band.
4. Remove all motors from the launcher and immediately place them in magazine storage.
5. On the launcher, rotate the detent-lift arm to the FIRE position and leave it in that position until ready to load the launcher again.

MAINTENANCE AND STORAGE

NOTE: These instructions should be studied carefully before the weapon components are stored, assembled, or loaded in launchers. The instructions should be referred to as necessary during these operations.

motor

General instructions for handling rocket motors apply to the ZUNI motor; however, because the length, weight, and thin web of the propellant grain make it susceptible to damage, extra precautions must be taken against dropping, jarring, or bumping the motor. A sudden jolt occurring as the result of a drop may crack the propellant grain. This could result in a motor blowup when the rocket is fired. Cracking of the propellant grain occurs more readily at low temperatures. Drops when carrying the motor in the horizontal attitude cause more severe damage than when dropped vertically.

WARNING

If the motor has been dropped so that any portion impacts after falling 18 inches or more, do not use. If convenient, return the motor to the issuing agency with a tag showing pertinent information.

WARNING

The shielding band must be left in place until just before the contact band enters the launcher during loading.

Standard magazine-storage regulations must be observed. The motor should be stored in a magazine with the temperature maintained below 90°F; however, storage at temperatures up to 100°F for less than 6 months is permissible. Prolonged storage above 100°F is dangerous.

WARNING

The temperatures stated on the motor tube apply. Do not store in or allow motors to be exposed to temperatures below the low-temperature limit for more than 1 hour before firing. If the motor has been so exposed, maintain it within the safe-firing temperature limits for at least 6 hours before firing.

CAUTION ! ! ! ! !

The motor must not be severely clamped because the thin-walled aluminum tube will deform easily, damaging the grain.

heads

The 5.0-Inch Rocket Heads Mk 32 Mod 0 (ATAP) and Mk 24 Mod 0 (GP) are usually shipped one or two to a container. A shipping plug with a gasket is screwed into the nose end and a shipping cap is screwed on the base end. These shipping plugs and caps should be left in place until the heads are to be assembled to motors and fuzes. This precaution will prevent damaged or dirty threads, which could make assembly of the rocket difficult or even impossible.

The 5.0-Inch Rocket Head Mk 26 Mod 0 (Illuminating) is delivered complete in a metal container (5.0-Inch Rocket Container Mk 24 Mod 0, BuOrd Dwg. 657764), which can be stacked horizontally for storage. Illuminating heads are subject to the same storage regulations as other pyrotechnic devices, such as illuminating projectiles, and are not authorized for ready-service stowage.

NOTE: The hygroscopicity (tendency to absorb moisture) of the pyrotechnic candle and the black-powder ejection charges makes cool, dry stowage of this head essential. Hence, it must be stowed in its moisture-proof metal container in a cool place. All unused heads should be returned to their containers.

Because the life of the explosive components of the head is not yet fully known, it is suggested that the oldest lots, as determined by the loading-station identification stamps, be used first.

Containers should be inspected periodically for external evidence of deterioration. If there are signs of deterioration, the container should be opened and the head should be examined for corrosion and the presence of fumes or chemical odors. If corrosion or fumes are evident, the head should be considered unsatisfactory and turned in or disposed of by dumping, in accordance with safety regulations in effect.

NOTE: Shipboard disassembly or repair of this illuminating head is **not** authorized.

fuzes

The fuzes are shipped in separate containers. All general handling, storing, and maintenance procedures and safety precautions for components containing high explosives apply.

lau-10/a launcher

Loaded launchers must be stowed in approved rocket magazines. The LAU-10/A launcher is both a combat launcher and a reusable training device. Therefore, reasonable care and maintenance should be exercised in its use. Continued satisfactory operation can be assured by cleaning the firing-contact points after every firing and before loading after extended non-use. Fine emery cloth should be brushed over the firing-contact points to ensure good contact. Care should be taken not to mark, scar, or burr the retainer rings, thus enabling repeated attachment of fairings. A fine file should be used to remove any scars or marks that do occur.

The launcher should have a minimum useful life permitting the firing of approximately 100 rockets, or 25 salvos. During wartime conditions or aircraft emergencies, the launcher may be jettisoned at the option of the pilot.

Launchers that incur tube damage serious enough to impair loading or firing of rockets shall be discarded without further use. Also launchers that develop operational difficulties that cannot be corrected by simple repair or parts replacement shall be discarded.

frangible fairings

The fairings in their container may be placed in any convenient inert storage place.

maintenance test of launcher

WARNING



Tests outlined in Steps 1 and 2 below shall never be conducted except on an empty or unloaded launcher.

1. To check the intervalometer, the following procedures should be employed, using a 24-40-volt-DC power source:
 - a. Remove the shorting device from one receptacle and place the other shorting device in the ARM position.
 - b. Attach positive lead to Pin A (electrical receptacle, Figure 15, page 10).
 - c. Attach negative lead to Pin E (ground).
 - d. Set selector switch on SINGLE position; apply voltage across Pins A and E; intervalometer should step once and stop, delivering a firing pulse to the No. 1 contact post. Repeat this operation for four pulses, at which time the intervalometer will stop on the original ZERO position.
 - e. Repeat Step 1d with selector switch on RIPPLE-OPTIONAL position; the intervalometer should run continuously, delivering a firing pulse successively to all contact points, then stop and "home" on the original ZERO position.

WARNING

Before reloading a used launcher, the intervalometer shall always be operated in accordance with Step 1e above and left in the home or ZERO position.

2. To check the intervalometer-to-rocket firing pulse, proceed in the following manner:
 - a. Arrange the shorting devices as specified in Step 1a.
 - b. Attach the positive lead of the voltmeter to the contact post located aft of the detent pawl (Figure 22).
 - c. Attach the ground lead of the voltmeter to any convenient portion of the launcher, such as the retainer ring or suspension lug.
 - d. Set the voltmeter on the lowest scale reading (0 to 2.5 VDC scale). (The voltmeter will not indicate current passage if a higher voltage scale is used, since the ignition pulse lasts for only 20 milliseconds.)
 - e. Set the selector switch on SINGLE.
 - f. Apply voltage across Pins A and E.
 - g. The voltmeter indicator arm will move quickly to indicate passage of current and return to ZERO position immediately. Repeat for each contact post.
 - h. Set the selector switch on RIPPLE-OPTIONAL.
 - i. Repeat Step 2f.
 - j. The voltmeter will pulse as in Step 2g and return to ZERO. With a single-channel voltmeter it will be necessary to repeat for each contact post.

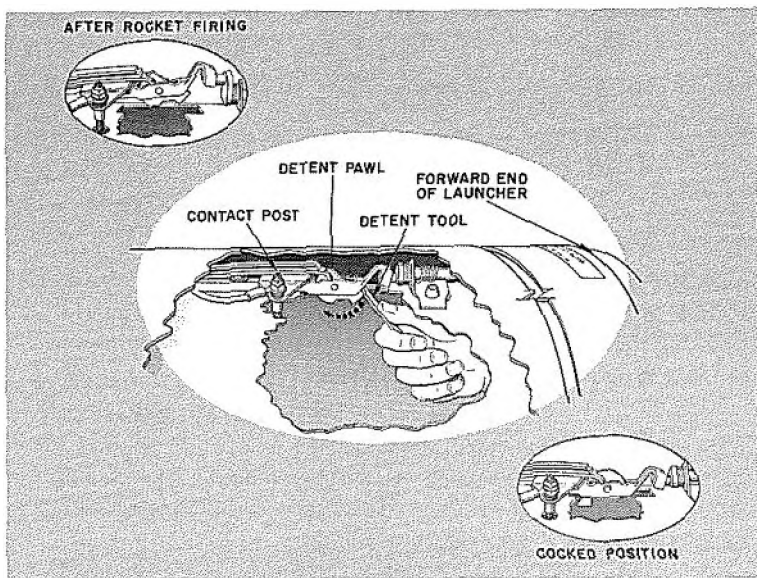

FIG. 22. Cutaway of Launcher Tube Showing Method of Detent Re-Cocking After Rocket Firing.

detent re-cocking procedure

To re-cock the detent after a rocket has been fired, proceed in the following manner:

1. Rotate the detent-lift arm to the FIRE position.
2. Insert the handle portion of the detent-lift tool into the launcher tube and engage the forward edge of the detent pawl within the detent-clearance hole in the launcher tube (Figure 22).
3. Push the detent pawl down and aft. The detent pawl will rotate about its axial pin and snap back into a cocked position.
4. Rotate the detent-lift arm to the LOAD position. The launcher is now ready to be reloaded.
5. If the launcher is not to be reloaded for some time, the detent-lift arm should be left in the FIRE position.

SAFETY PRECAUTIONS

general safety precautions

All safety precautions normally followed in handling rockets shall be observed. The precautions include the following:

1. Adhere to all storage conditions specified for smokeless powder and high explosives.
2. Store motors only in approved rocket-motor magazines. Do not store adjacent to electrical panels or live wires. Comply with existing restrictions for the handling and loading of ordnance while in electromagnetic fields.
3. Do not fire rocket motors when the propellant temperature is outside the safe-firing temperature limits specified on the motor tube. If the motor has been exposed for more than 1 hour to temperatures outside these limits, maintain it within the safe-temperature limits for 6 hours before firing.
4. Handle motors carefully at all times. Avoid jarring or dropping the motor, as a cracked propellant grain may be the cause of a motor blowup on firing. Motors dropped more than 18 inches should be returned to the issuing agency. Motors dropped less than 18 inches should be examined for external damage; if no damage is evident, they may be considered safe for use.
5. Do not tamper with or attempt to repair any parts of the round. If the round is damaged or defective, remove the head from the motor and mark the defective part for return to the issuing agency.
6. Do not remove the shielding band from the contact band until just before loading the round into the launcher. Always immediately place the shielding band on rockets removed from the launcher.
7. **MAKE SURE THE FIRING SYSTEM CANNOT BE ENERGIZED DURING LAUNCHER LOADING AND UNLOADING OPERATIONS.**
8. Keep well away from the front and rear of rockets loaded or unloaded.

launcher loading and unloading precautions

Before performing any operation of loading rockets or rocket motors into the launcher or removing rockets or rocket motors from the launcher, make sure that all applicable conditions of safety have been complied with as follows:

1. Do not attempt to load or unload either completely assembled rockets or rocket motors in the vicinity of radio-transmitting antennas. Refer and conform to current restrictions on handling and loading ordnance in electromagnetic fields.
2. Make sure that the launcher firing circuit is not, nor can be, energized, and at least one shorting device is in place in the SAFE position.
3. Under certain conditions at shore stations, it may be desirable to load or unload launchers while suspended on the aircraft. Before doing so, refer to safety conditions 1 and 2 above.
4. For shipboard operations, the rocket motors shall be installed in the launcher in the safe area, preferably below deck. The launcher shall be properly suspended from the aircraft, then the rocket heads with fuzes shall be screwed into the motors, and frangible fairings placed on the launcher. Unloading operations shall be accomplished in the reverse of the above procedure.
5. Partially fired launchers shall be unloaded in accordance with the above procedure. Continuity checks, intervalometer checks, and positioning shall be accomplished in accordance with the instructions in the section on MAINTENANCE AND STORAGE.
6. The rocket shielding band shall be in place on the rocket motor at all times when it is not in the launcher.
7. For shore-station ground-firing operations, in the event of a misfire or hang-fire, no attempt shall be made to remove the rocket from the launcher until the prescribed waiting period of 10 minutes has been observed and the ignition circuit has been made completely safe.
8. Before installing a rocket motor or complete rocket in the launcher, make a careful inspection to ensure that the round is

properly assembled. Do not load the round into the launcher if the fins are bent appreciably or if parts show visible damage.

WARNING



Mk 24 Mod 0 Head ONLY

1. No attempt should be made to remove the base fuze except by qualified bomb-disposal personnel.
2. Leave heads in shipping container as long as possible when loading aboard or striking down.
3. When off-loading provide shipping container Mk 34 box or Mk 11 pallet adapter. Secure to pallet to prevent rolling off.
4. When handling individual heads use extra caution. **DO NOT DROP.** Treat any head dropped more than 10 FEET AS ARMED.

**special safety precautions
for mk 26 mod 0 head
(illuminating)**

The handling and use of the 5.0-Inch Rocket Head Mk 26 Mod 0 will not involve unusual hazards if the following safety precautions are observed:

1. Avoid exposing the head to temperatures above 100°F and store in a place protected from moisture.
2. Ground heads and isolate them from electrostatic charges.
3. Heavy parts are ejected when the illuminating head functions. Hence, pilots should use discretion in firing the flare rockets to avoid endangering friendly ground forces.
4. As the flare burns, its weight decreases. The rate of descent of the expended flare is, therefore, about 10 feet per second—substantially slower than during the burning period. Pilots are, therefore, advised to avoid the region below the point of flare burnout long enough to eliminate the possibility of colliding with expended flares.

INITIAL DISTRIBUTION

23 Chief, Bureau of Ordnance

Ad3 (1)

Ad4-2 (1)

Ad4-c (1)

Ad5-2 (1)

Ma (2)

E. M. Moes (1)

Ma3 (1)

Ma9 (1)

PLc (1)

PLd (1)

PL5 (1)

Red1 (1)

Red4 (1)

Rep-3 (1)

Req (1)

ReO (1)

ReO6 (1)

ReS (1)

ReS6 (1)

ReU3 (Dr. Land) (1)

ReW (1)

ReW3 (1)

ReW4 (1)

10 Armed Services Technical Information Agency (TIPCR)

ZUNI