

UNCLASSIFIED

NAVORD REPORT 1248

ATI 84949

AD B954297

MANUAL FOR SHAPED-CHARGE DESIGN

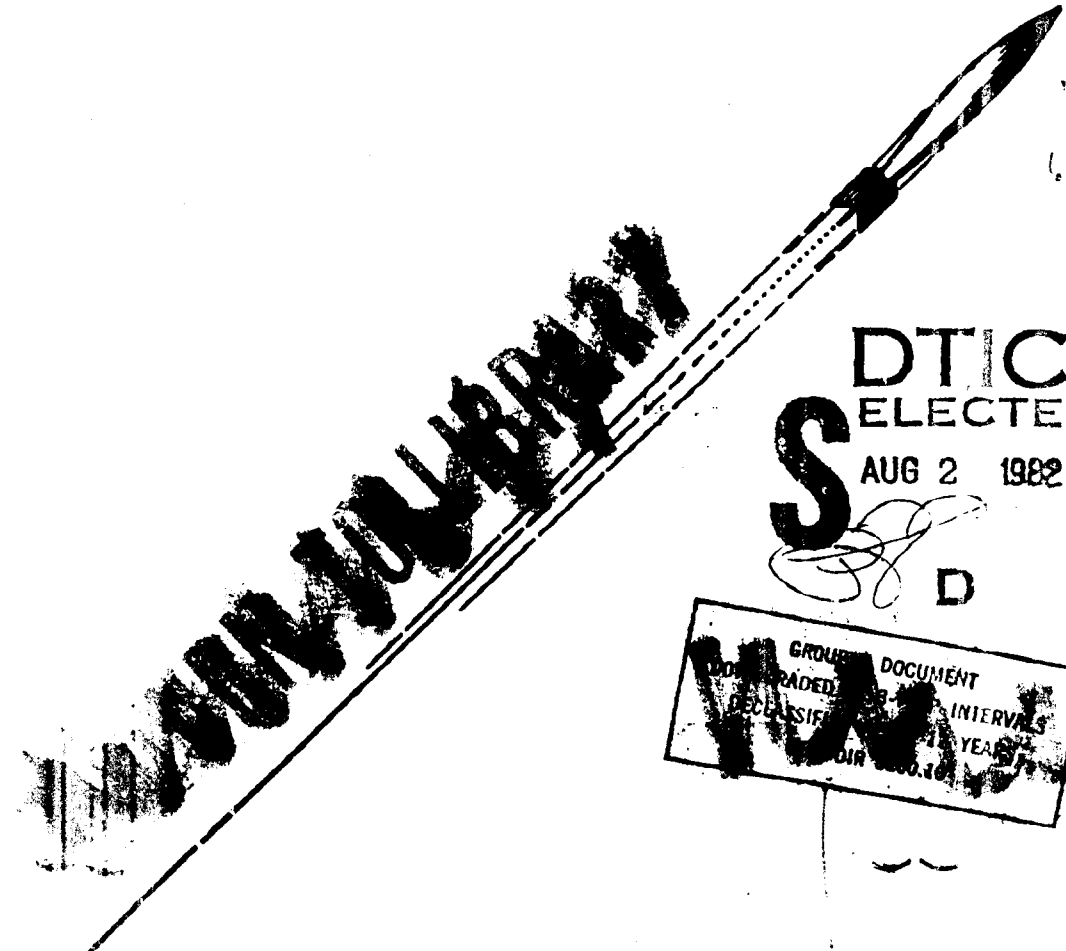

DTIC
ELECTE
AUG 2 1982
S D

GROUP DOCUMENT
DO NOT GRADE
DECLASSIFY
INTERVALS
YEAR

DTIC FILE COPY

UNCLASSIFIED

NOTS 311

8.2 07 30 135 17 AUGUST 1950



U.S. NAVAL ORDINANCE TEST STATION

NAVORD Report 1248 (NOTS 311) is the approved version of MS/1742-1 published by the Technical Information Division. It consists of cover and 21 leaves. From the original printing of 200 copies this document is

COPY N^o 117

ERRATA

Page iii. *Add as third paragraph:* This report was reviewed for technical accuracy by John S. Rinehart and Milton Blatt.

Page 30, item 13: *for* California Institute of Technology *read* Carnegie Institute of Technology; *for* Pasadena, Calif. *read* Pittsburgh, Pa.; *for* (CIT/ORD 20) *read* (CIT-ORD-20).

Page 30, item 14: *for* Pasadena, Calif. *read* Pittsburgh, Pa.; *for* (CIT/ORD 19) *read* (CIT-ORD-19).

Page 30, item 15: *for* Pasadena, Calif. *read* Pittsburgh, Pa.; *for* (CIT/ORD 23) *read* (CIT-ORD-23).

(NAVORD Report 1248)

UNANNOUNCED

UNCLASSIFIED



U. S. NAVAL ORDNANCE TEST STATION, INYOKERN
CAPT. W. V. R. VIEWEG, USN
Commander

MANUAL FOR SHAPED-CHARGE DESIGN

By

Robert A. Brimmer

Commander's Staff

| | |
|---------------------|-------------------------------------|
| Accession For | |
| NTIS GRA&I | <input type="checkbox"/> |
| DTIC TAB | <input type="checkbox"/> |
| Unannounced | <input checked="" type="checkbox"/> |
| Justification | |
| By _____ | |
| Distribution/ _____ | |
| Availability Codes | |
| Dist | Avail and/or Special |
| 2 | |

NAVORD REPORT 1248

NOTS 311

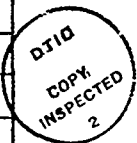

China Lake, California
17 August 1950



UNCLASSIFIED

UNCLASSIFIED

~~CONFIDENTIAL~~

ACKNOWLEDGMENT

The author wishes to acknowledge the help of Brian B. Dunne who prepared the work on theory and explosives. He also contributed other helpful information used throughout the report. The excellent and varied help given by Peter B. Weiser during the writing of this report is also acknowledged.

UNCLASSIFIED

~~CONFIDENTIAL~~

UNCLASSIFIED

NAVORD REPORT 1248

FOREWORD

This report is a design manual compiled from the best available information and should be a guide for the practical designer. The assembling of the information in this report was done under the guidance of the Shaped Charge Working Panel, Naval Ordnance Test Station, at the request of the Technical Director.

The need for such a report became quite evident when this Station was designing the RAM Warhead, under Local Project 617. There was a great quantity of information available, but much time was required to go through it and pick out the information needed. It is hoped that this report will provide the necessary siting and classification of the pertinent information.

JOHN H. SHENK

Head, Research Department

UNCLASSIFIED

UNCLASSIFIED
~~CONFIDENTIAL~~

ABSTRACT

This manual is intended for the practical designer of shaped charges. It contains little theory, but is a compilation of the best available information on the penetration of various charges and the explosives used. Examples of present designs and proposals for further designs of shaped charges are listed.

UNCLASSIFIED
CONFIDENTIAL

CONTENTS

| | Page |
|--|------|
| Foreword | iii |
| Abstract | iv |
| Introduction | 1 |
| Theory | 1 |
| Definitions | 1 |
| Factors Affecting Penetration | 1 |
| Charge | 1 |
| Defects in Shaped Charge Manufacture | 7 |
| Confinement | 8 |
| Fuzing | 10 |
| Stand-off and Air Space | 11 |
| Liner | 14 |
| Targets | 17 |
| Terminal Velocity | 18 |
| Truncation | 18 |
| Rotation | 19 |
| Penetration Data | 19 |
| Shaped Charge Design | 19 |
| Further Proposals | 19 |
| Fluted Liners | 19 |
| Hemispherical Liners | 28 |
| Target Design | 28 |
| Paper Flash-Back Tubes | 28 |
| References | 29 |

ILLUSTRATIONS

| Figure | | Page |
|--------|--|------|
| 1 | Schematic Drawing of a Shaped Charge and Target . . . | 2 |
| 2 | Depth of Penetration vs. Charge Length | 2 |
| 3 | Triangular Deformation | 7 |
| 4 | Steel Target Penetration by 4 3/8-in. Diameter Steel Cones Having Tapered Walls | 9 |
| 5 | Depth of Penetration vs. Wall Thickness | 10 |
| 6 | Stand-off vs. Penetration in Cone Angle | 11 |
| 7 | Cone Angle vs. Penetration by Stand-off | 12 |
| 8 | Stand-off vs. Penetration by Material | 13 |
| 9 | Air Space vs. Range | 13 |
| 10 | Cone Angle vs. Maximum Range | 14 |
| 11 | Penetration of Protective Material vs. Penetration of Mild Steel | 15 |
| 12 | Jet Penetration Against Spaced Armor | 17 |
| 13 | Jet Penetration vs. Rotation | 18 |
| 14 | Penetration of Concrete by Detonation of Cone-End Charges | 20 |
| 15 | Perforation of Homogeneous Armor by Weapons With Cone-End Charges | 21 |
| 16 | 105-mm Howitzer Fin-Stabilized H.E.A.T. Round . . . | 22 |
| 17 | Anti-Submarine Follow-through Bomb, Modified | 23 |

ILLUSTRATIONS (Continued)

| Figure | | Page |
|---------------|--|-------------|
| 18 | 3.62" Head for F59 Rocket | 23 |
| 19 | 3.62" H.E.A.T. Rocket Head Bearing M67 Copper Cone With 2.36" T59 Motor | 24 |
| 20 | Fastax Record of 3.62" H.E.A.T. Round Striking Target at Normal Incidence | 24 |
| 21 | The German 88-mm A. T. Rocket | 25 |
| 22 | Diagram and Sectional Head of U.S. Army Rocket H.E.A.T. T69 | 26 |

INTRODUCTION**THEORY**

Theoretical treatment of the collapse process, jet flight, and penetration can be found in detail elsewhere. The theory proposed by Taylor (Ref. 10) and Birkhoff (Ref. 11, 12), modified by Pugh (Ref. 13, 14), presents the most widely accepted picture of the collapse process. Jet flight and penetration theories have been advanced by a number of investigations (Ref. 12, 14, 15). Flash radiographs taken by Clark and Seely (Ref. 16, 13) aid in understanding these treatments. Another good treatment of this subject may be found in Ref. 1.

DEFINITIONS

The following are definitions commonly used in connection with shaped-charge design.

Air Space. The water-free space in front of the cone of a shaped charge used in underwater weapons which allows time for jet formation.

Confined. A shaped charge contained in some type of rigid container.

Effective Penetration Depth. The depth of the resulting hole measured normal to the target surface.

Penetration Depth. The depth of the resulting hole measured along the charge axis.

Unconfined. A cavity liner and bare charge.

There is good agreement on shaped-charge terminology. The terms commonly used are shown in Fig. 1 which is a diagrammatic sketch of a shaped charge and target. These terms will be used throughout this report.

FACTORS AFFECTING PENETRATION**CHARGE****CHARGE LENGTH**

The effect of charge length on the depth of penetration into steel when fired in air is shown in Fig. 2. When used in tactical weapons, the charge length is usually taken between 2.5 and 3.0 charge diameters even though a length of 5.0 charge diameters gives somewhat greater penetration (Ref. 1).

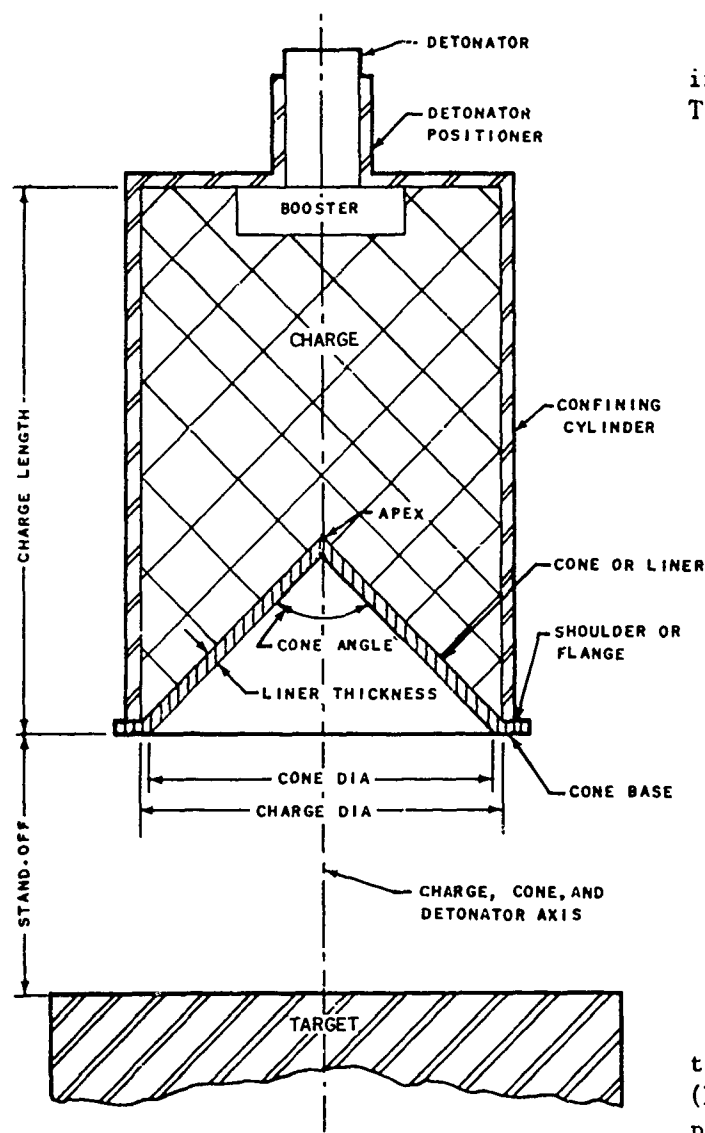
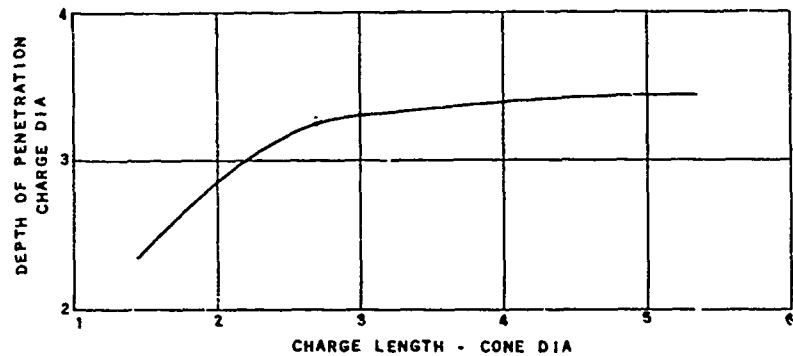

Fig. 1. Schematic Drawing of a Shaped Charge and Target.

Fig. 2. Depth of Penetration vs. Charge Length (Reproduced From Fig. 1, p. 68 of Ref. 1).



The curve in Fig. 2 is for 50/50 Pentolite. Curves for other explosives may fall above or below the one given, changing the depth of penetration, but the general shape of the curve will remain the same.

The effect of charge length when fired under water is quite similar to that shown in Fig. 2. Maximum range is obtained with a 3.0 caliber length. A decrease to 2.4 calibers lowers the range only 10 percent below the maximum (Ref. 1).

EXPLOSIVES

Table 1 lists the characteristics of explosives commonly used in shaped charges. In general, the explosive characteristic most desirable is high detonation pressure, combined with high detonation velocity. Aluminum and other constituents which do not react rapidly enough to contribute to the detonation pressure during the passage of the detonation wave over the cavity liner are ineffective in small charges. Aluminized explosives can be used effectively for large charges.

CORED CHARGES

It has been suggested (Ref. 3) that an improvement in shaped-charge performance might be gained by shaping the detonation wave so that its incidence on the liner would be closer to the normal than in the conventional shaped charge. The British performed experiments using a cylindrical core of TNT inside the main charge. This gave an improvement in penetration into concrete of 25 percent higher than the standard shaped charge.

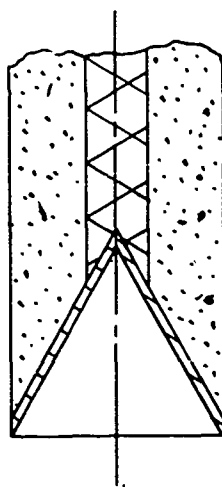

Similar tests were tried in this country, giving an average of 15-20 percent increase in penetration over regular charges. Similar improvement has been obtained with inert cores such as wood, but in this case the core had to end short of the cone apex so that all of the cone surface could be covered by explosive.

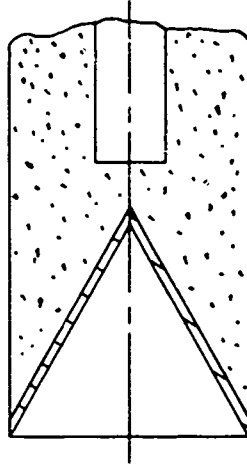

Since the above tests were all performed with unconfined charges, the same thing was tried with different degrees of confinement. It was found that by using cores and partial confinement (leaving approximately 1/2 inch of bare charge above the cone base) the penetration could be increased by almost 40 percent.

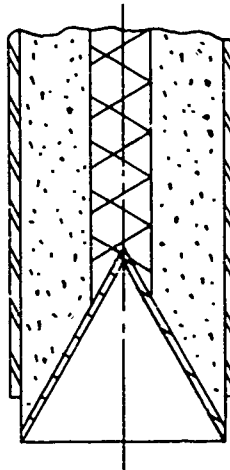

The same thing has been tried with cones containing flash-back tubes (Ref. 4). The diameter of the core seems to be more critical in this case, with the inert core giving no increase in performance although it had no bad effect.

TABLE 1
Shaped-Charge Explosives

| Designation | Loading Density g/cc 25°C | Physical Form (Loaded) | Detonation Velocity meters per sec | Relative Power ^a | Sensitivity ^b | Stability ^c | Remarks |
|------------------------|---|---|---|--------------------------------|--------------------------|------------------------|---|
| Pentolite 50/50 | 1.65 | cast | 7,500 | 110 | 5 | moderately stable | Used chiefly in shaped charges; penetration is 90-95% that of 65/35 Cyclotol. More sensitive than 65/35 Cyclotol. |
| Cyclotol 65/35 | 1.71 | cast | 7,790 | 114 | -- | -- | Better for filling small shaped charges. |
| Cyclotol 70/30 | 1.725 | cast | 7,790 | 114 | -- | -- | One of most effective shaped charge explosives; too viscous to load small shaped charges. |
| RDX | 1.60 | cast | 8,110 | -- | -- | fairly stable | Samples stored 2.5 yr. at ordi- nary temp. found to be perfect. Germans used pressed pre-formed pellets in shaped charges (Comp. A: RDX 90%, wax 10%); not used alone in shaped charges. |
| Comp. B | 1.60 | cast | 7,500 | 117 | 7 | very stable | About 20% more effective than cast TNT; high shaped charge efficiency; good loading char- acteristics; sensitive to shock. |
| Comp. C-2 (Du Pont) | 1.57 | plastic | 7,800 | -- | -- | -- | Hardens when stored at elevated temperature. |
| Comp. C-3 | 1.58 (1.47) | plastic | 7,800 | -- | 9 | moderately stable | Comp. C modified to provide a good explosive for molded and shaped charges; tends to harden in storage; special packaging needed to prevent exudation even at 55°F. |
| PTX-2 | 1.712 | castable, similar to Comp. B | -- | 118 | -- | stable | Developed by Picatinny Arsenal as castable filling for shaped charges. |
| TNT | 1.57-1.59 cast 1.55-1.61 pressed | small charges, pressed; medium & large charges, cast | 6,800 | 100 | 9 | very stable | Used for blasting, demolition. |
| HBX | 1.65 | cast | 7,100 | 113 | 8 | stable | Intended as replacement for Torpex in depth bombs; genera- tion of hydrogen may deform cavity. |
| Torpex 2 | 1.71 | cast | 7,200 | 116 | 6 | very stable | Mainly used in underwater ord- nance; generation of hydrogen may deform cavity. |

^aPower of an equal volume of explosive relative to TNT (= 100), based on the fragmentation velocity of TNT.

^bOn a scale of 10, class 1 is most sensitive, class 10 is least sensitive.

^cThose classified as moderately stable will survive all but drastic tropical storage, stable and very stable will survive this.

Fig. 3. Triangular Deformation.

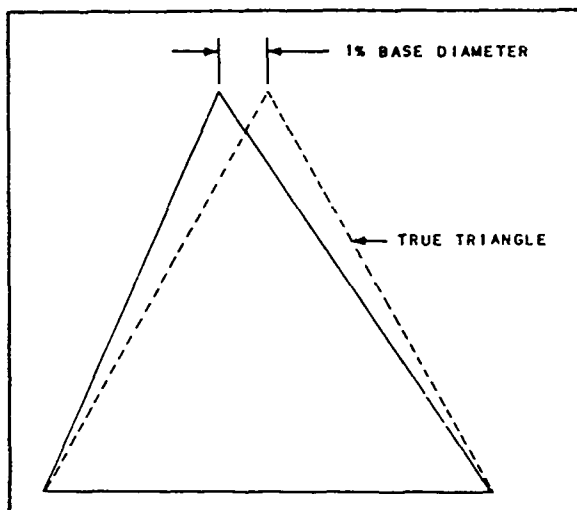

DEFECTS IN SHAPED CHARGE MANUFACTURE

CHARGE IMPERFECTIONS

Care should be taken, when casting an explosive into a shaped charge, that bubbles are not formed at the base of the liner. If they occur close to or at the apex, little harm is done to the penetration of the resulting jet (Ref. 5).

There is some feeling that a non-uniform crystalline structure in the explosive might decrease the depth of penetration.

CONE INCLINATION

It has been shown in Ref. 7 that the cone and charge axis may be inclined only 0.5 degrees with respect to each other without causing serious impairment of the jet formation and subsequent penetration.

CONE ELLIPTICITY

A cone may show an ellipticity of 1 percent of the cone diameter without significant effect on the performance. A difference of 1.7 percent results in a decrease of more than 10 percent in penetration (Ref. 6).

TRIANGULAR DEFORMATION

A triangularly deformed cone showing a difference of as much as 1 percent of the base diameter (Fig. 3) gives a penetration 10 percent

below the normal (Ref. 6). A difference of 0.5 percent could probably be tolerated without significant harmful effect.

DETONATOR MALALIGNMENT

The off-center placement of the detonator caused by manufacturing tolerances will have little if any effect on the jet penetration. A large displacement (10 percent of the charge diameter) will cause scattering of the jet and a decrease in the depth of penetration unless the charge is very long (Ref. 5).

OBJECTS IN CAVITY

Wires, rods, and other solid inert materials in the cavity of the cone adversely affect penetration by interfering with the jet formation (Ref. 5). Where wires must pass through the cavity they should be placed as close to the circumference of the base as possible. When materials are self destructing and are cleared from the cone cavity before the jet forms, penetration will not be affected.

HOLES IN CONE

If holes through the cone wall are necessary for any reason, it is preferable to place them at the apex in a symmetrical pattern.

TAPERED WALLS

Penetration will not be affected if the walls of the cone are tapered so that the thick part is at the base (Ref. 5). Penetration is decreased if the walls are thicker at the apex than at the base (Fig. 4).

WELDED CONES

When welded steel cones are used, the bead weld next to the explosive should be ground down so that a smooth surface is maintained on this face of the cone. It is not necessary to remove the bead on the inside (Ref. 8). *CONFIDENTIAL*

CONFINEMENT

Confinement of a charge does not seem to affect the penetration appreciably if the cone is designed for the degree of confinement. The

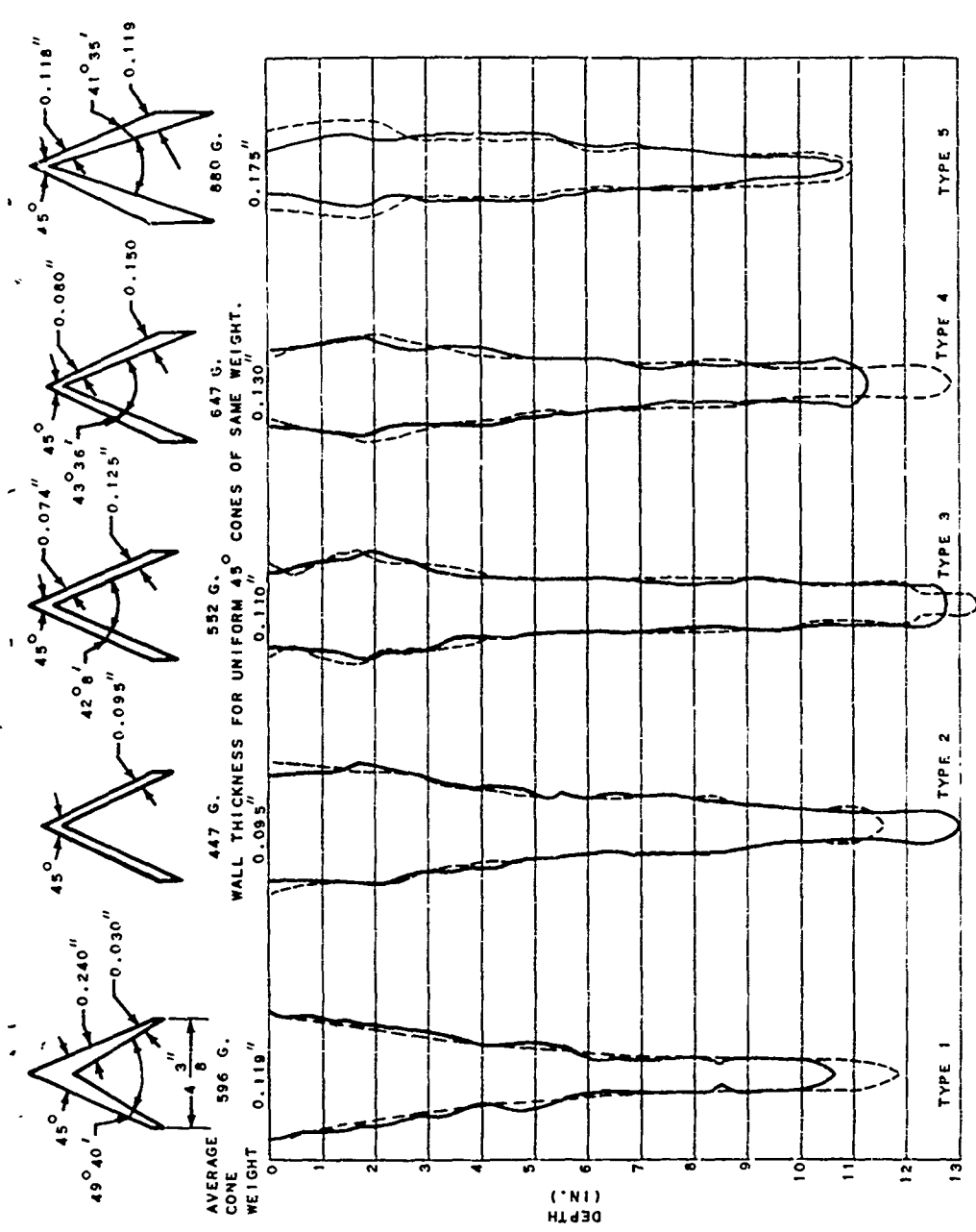

Fig. 4. Steel Target Penetration by 4 3/8" Diameter Steel Cones Having Tapered Walls. Confinement, 1/16" steel; stand-off, 6". (Reproduced from Fig. 1 of Ref. 5.)

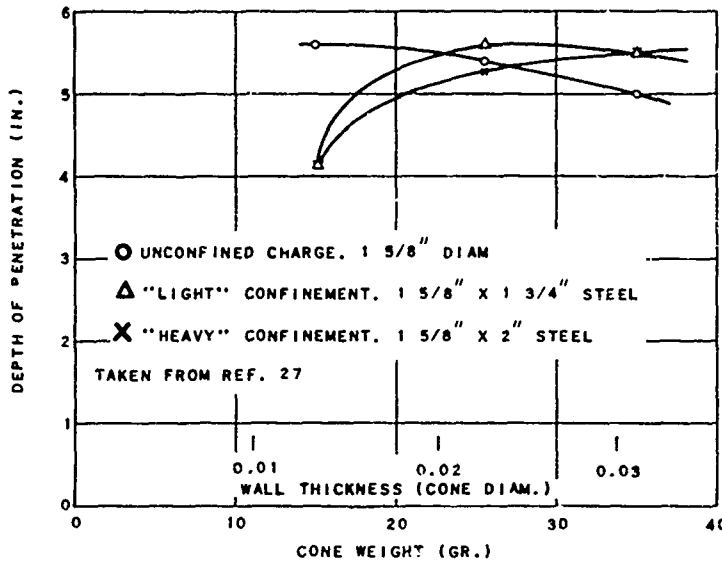

Fig. 5. Depth of Penetration vs. Wall Thickness (Reproduced From Fig. 5 of Ref. 27).

optimum liner weight and thickness are greater for confined than for unconfined charges. The optimum wall thicknesses for 45 degree steel cones with three degrees of confinement are summarized below and in Fig. 5.

| <u>Confinement</u> | <u>Approx. Optimum Wall Thickness for 45° Steel Cones (% of base diameter)</u> |
|--|--|
| None or very light | 1.5 |
| Light (cross-sectional charge wt/ casing wt. = 1.3) | 2.5 |
| Heavy (cross-sectional charge wt/ casing wt. = 0.4) | 3.5 |

The optimum wall thicknesses given are approximately correct for 45 degree copper cones (Ref. 1).

FUZING

The actual design of fuzing is beyond the scope of this report, although a few precautions should be mentioned. If a nose fuze is used, it must not interfere with the jet formation. This may be accomplished by placing it far enough ahead of the charge that it acts only as an additional

Fig. 6. Stand-off vs. Penetration in Cone Angle (Reproduced From Fig. 2, p. 69 of Ref. 1).

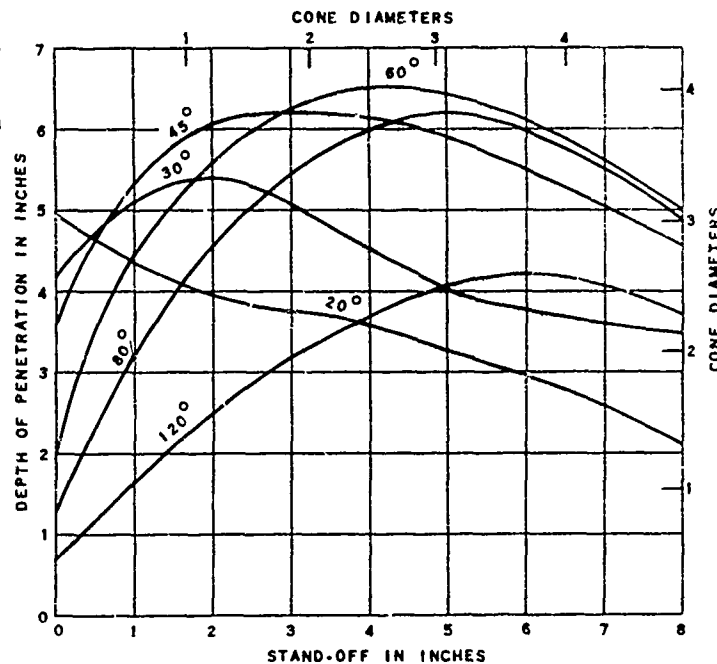

target, or by making it in an annular shape with a sufficiently large diameter hole that the jet may pass through it. Great care must be taken not to allow metal parts, such as wires, rods, or striking pins, to hamper the jet formation.

A good discussion of specific fuzes may be found in Ref. 1.

STAND-OFF AND AIR SPACE

STAND-OFF

Most cavity charges show an increase in depth of penetration when the stand-off is increased from zero to some optimum distance. Exceptions are unlined charges and charges having 20 degree steel cones; these perform best at zero stand-off (Ref. 1). Typical depth-of-penetration versus stand-off curves for steel conical liners of 1 5/8-inch diameter and various cone angles in unconfined charges are shown in Fig. 6.

It will be noticed in Fig. 6 that the curves are plotted for a 1 5/8-inch cone, but that at the top and right of the graph cone diameters are given. These values may be scaled for a cone of any diameter (Ref. 1). The fact that the data used for plotting these curves were for unconfined charges would probably indicate a larger value of stand-off than the optimum for a confined charge. This difference is not large enough to affect the penetration a significant amount.

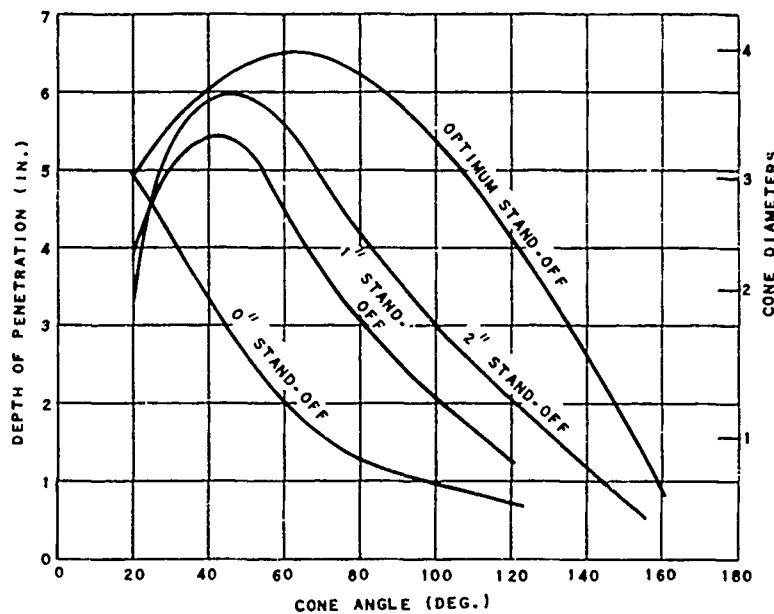

Fig. 7. Cone Angle vs. Penetration by Stand-off
(Reproduced From Fig. 3, p. 70 of Ref. 1).

Figure 7 is a plot of cone angle versus depth of penetration at different stand-off values.

Figure 8 is a plot of stand-off versus penetration for different cone materials. All of the cones were steel-confined. The curves for zinc and lead were taken from material prepared at the Naval Powder Factory.¹

AIR SPACE

Corresponding to stand-off in air, underwater shaped charges require some air space (Ref. 1) beyond the charge to allow for complete liner collapse. In general, the optimum air space for maximum range varies with liner shape and material much as does stand-off. The optimum air space is shorter than the optimum stand-off. The optimum air space is in effect the shortest air space at which the maximum range of the jet is obtained consistently.

Typical results are shown in Fig. 9 for unconfined 1 5/8-inch cast Pentolite charges. Additional data for 20- and 30-degree cones, not included in Fig. 9, indicate that for these liners the optimum air space is zero.

¹Ditto material from the Ordnance Investigation Laboratory, Naval Powder Factory, on "The Cavity Charge, Its Theory and Applications to the Opening of Explosive Filled Ordnance and Other Special Cutting and Drilling Operations," by H. W. Kline, Lt., USNR, with the assistance of J. F. Nachman, Lt. (jg), USNR, dated 15 August 1945, CONFIDENTIAL.

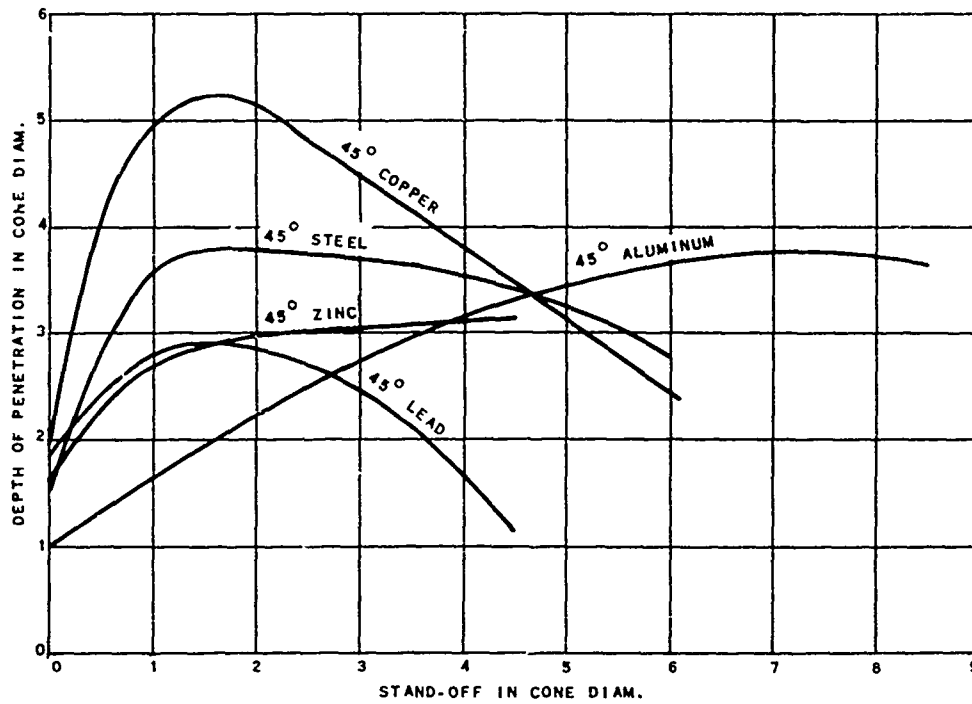

Fig. 8. Stand-off vs. Penetration by Material (Reproduced From Fig. 4, p. 71, of Ref. 1).

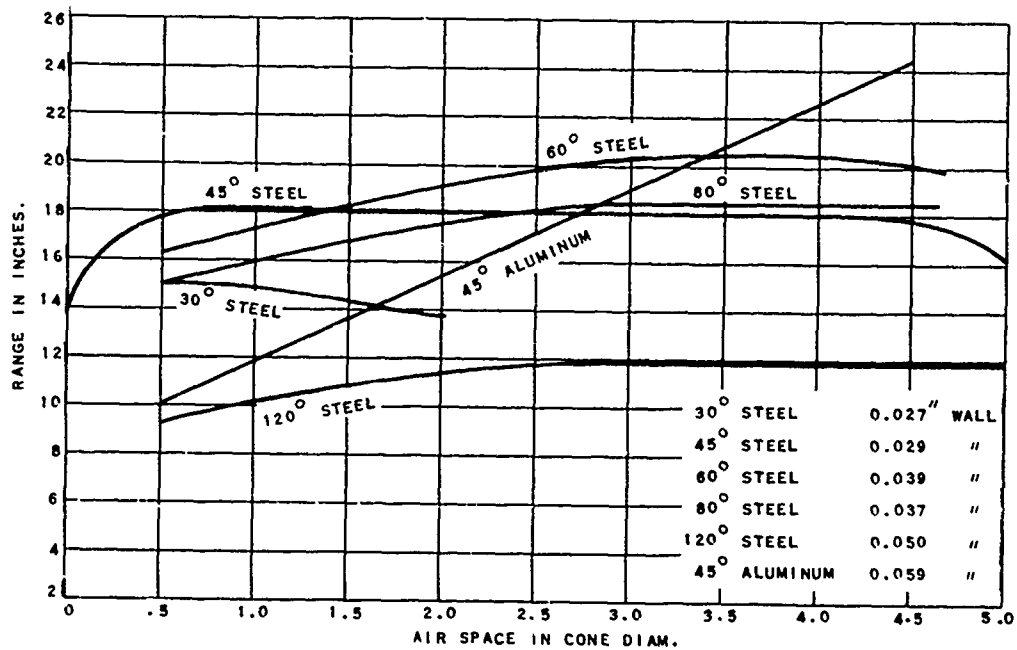

Fig. 9. Air Space vs. Range (Reproduced From Fig. 5, p. 75 of Ref. 1).

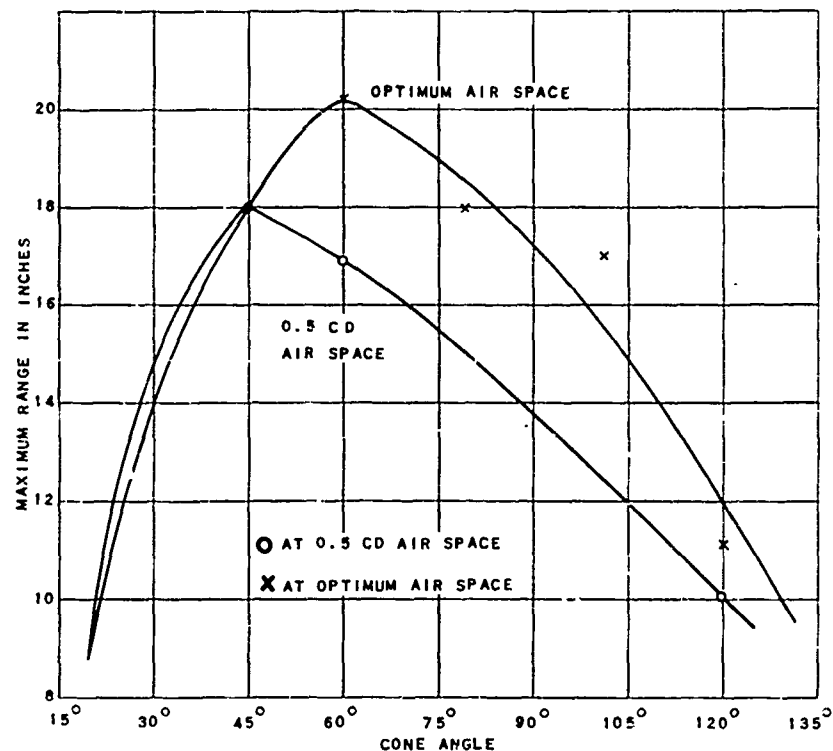

Fig. 10. Cone Angle vs. Maximum Range (Reproduced From Fig. 6, p. 75, of Ref. 1).

Figure 10 shows the range for various cone angles at 0.5 charge diameters and at optimum air space, using steel cones. The charges were unconfined Pentolite. The range could be improved about 10 percent by using Composition B.

Figure 11 shows the actual penetration into mild steel after the jet has passed through a given thickness of protective material. The protective material is that material through which the jet must pass before entering the armor. It may be noted that as the density of the protecting material increases the actual penetration into mild steel decreases.

LINER

CONE ANGLE

Cone angle affects the depth of penetration as may be seen in Fig. 6 and 7 when the charge is fired in the air. For underwater penetration, one may refer to Fig. 10.

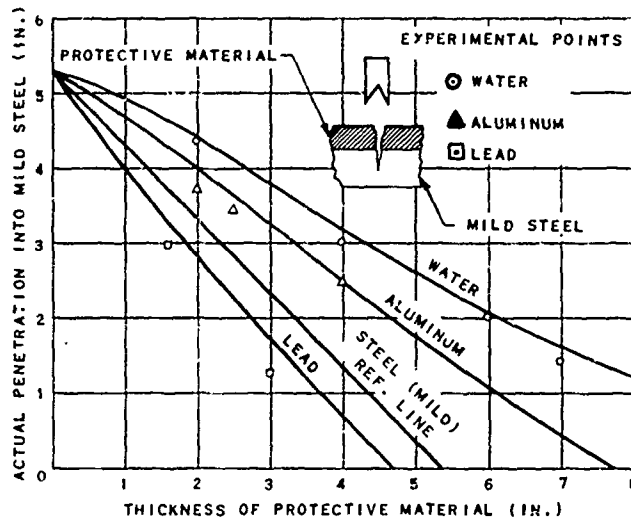

Fig. 11. Penetration of Protective Material vs. Penetration of Mild Steel (Reproduced From Fig. 2, p. 106, of Ref. 28).

CONE DIAMETER

The penetration increases approximately linearly with cone diameter.

LINER MATERIAL

The material out of which the liner is fabricated has a very marked effect on the penetration. The penetration using five cone materials is plotted in Fig. 8. Other materials used are listed below.

Brass. This metal gives results quite similar to steel (Ref. 17, 18). It has the advantage of being somewhat easier to work in large-size cones but has not been used in actual weapons.

Glass. Glass is used in demolition charges for the penetration of concrete even though it is inferior to steel. It produces a larger hole diameter and volume, and does not leave as much debris as does a steel cone (Ref. 1).

Phosphor Bronze. This is a very poor material for a cone.

Red Brass. This is a very good material which falls between copper and steel in penetrating power. This metal contains 80 percent copper (Ref. 18).

Steel. Although steel is used in many cones, it is necessary to note the type of steel which gives the best results, since the word "steel" covers a great variety of compositions. Steel must be almost "dead" soft (Rockwell hardness 65-72B, Ref. 19). When the cone becomes so large that it has to be rolled and welded from sheet steel, the weld should be a double V-bead, smoothed off on the outside (Ref. 8). The entire cone should be heat-treated by normalizing for 15-30 minutes at 1600°-1625°F followed by furnace cooling. It is also believed best to normalize drawn cones at 1150°-1250°F for 1 hour and then air cool to be sure of uniform structure (Ref. 20).

Zinc. Zinc was tried by the Germans even though the material produces very poor penetration. The reason for its use was the increased incendiary effect.

SHOULDER

The configuration of the liner base where it joins the casing is important. If the true cone base diameter is smaller than that of the charge and if the cone is supported by a flat base flange covered by explosive, the performance is seriously impaired under certain conditions. In general, for a confined charge, the true cone diameter should be the full diameter of the charge at the place where the cone is secured to the casing (Ref. 1).

The explosive shoulder around the cone does not seem to be as detrimental when the charge is unconfined.

LINER TAPERING

The effects of tapering the liner are covered in the section on Tapered Walls and in Fig. 4.

LINER THICKNESS AND WEIGHT

The optimum liner weight varies but slightly with the apex angle for conical liners of a given base diameter (Ref. 1). The optimum liner thickness for a given metal is thus proportional to the sine of half the apex angle, though it may be somewhat greater for cones more acute than 45 degrees. While exhaustive tests have not been carried out on metals other than steel, the available evidence indicates that the optimum weight is not very different for other metals, including copper and aluminum. At any rate, the performance is not affected critically by the precise liner weight (Ref. 9).

TARGETS

HOMOGENEOUS ARMOR AND REINFORCED CONCRETE

For experimental purposes, mild steel is used as the target for many shaped charges, but homogeneous armor and reinforced concrete are the principal combat targets. For a wide range of steel cones, the depth of penetration into homogeneous armor is 84 percent of that in mild steel. For a copper cone the penetration is 74 percent. Although this seems to contradict the previous illustration that copper is a better material for cones (Fig. 8), it actually does not since a copper cone of the same diameter as a steel cone will give a penetration of one charge diameter greater than the steel cone in a mild steel target. For example: if we have a 6-inch steel cone and a 6-inch copper cone, the approximate penetration into mild steel for the two cones will be 18 and 24 inches respectively. When these penetrations are multiplied by the correction factor for homogeneous armor, we find that the steel cone gives a penetration of 18 inches \times 0.84 = 15.2 inches; while for copper we have 24 inches \times 0.74 = 17.8 inches. The hole diameters in armor are 80 percent of the diameters in mild steel. The depth of penetration into reinforced concrete is roughly 3.2 times the depth of penetration into homogeneous armor.

SPACED ARMOR

Much thought has been given to using spaced armor as a defense against shaped charges. Figure 12 shows some expected performances.

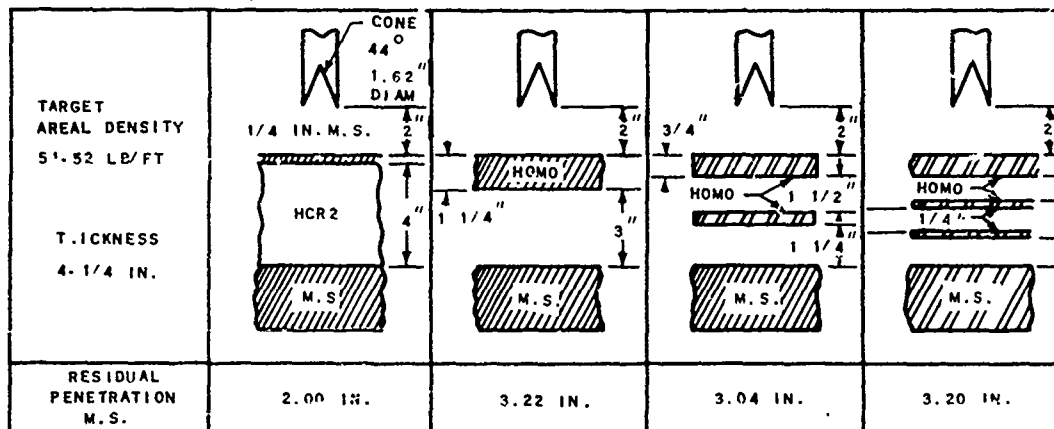

Fig. 12. Jet Penetration Against Spaced Armor (Reproduced From Fig. 9, p. 114, of Ref. 28).

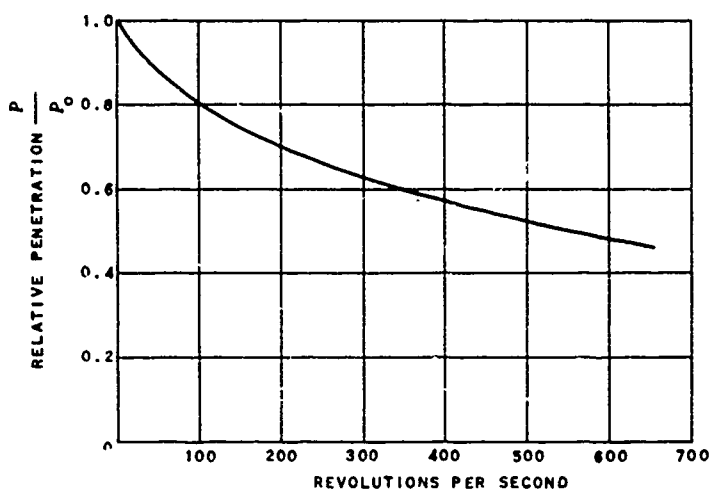

Fig. 13. Jet Penetration vs. Rotation. Estimated accuracy is ± 25 percent. (Plotted from data given on p. 417 of Ref. 25.)

STRIKING ANGLE

The angle of obliquity at which the projectile strikes the target has little effect upon the depth of penetration measured along the charge axis up to 84 degrees. The effective penetration D may be found by

$$D = L \sin \theta$$

where

D = effective penetration

L = depth of penetration

θ = angle between the target and projectile plane

TERMINAL VELOCITY

The terminal velocity of the shaped-charge projectile has little if any effect on the penetration.

TRUNCATION

Truncation of conical liners was first considered when it was desired to use a nose fuze with a small shaped charge and a spit-back tube down the center of the charge. It was found that no adverse effect was produced, and in some cases an improvement was noticed (Ref. 21). In tests performed at the Explosives Research Laboratory, the apexes of cones were filled to varying depths with solder. A 1 5/8-inch cone was filled to 0.4 inch above the apex and perfectly normal penetration still existed. When filled to 0.9 inch, the penetration was decreased by 20 percent (Ref. 19).

ROTATION

Rotating the charge about its axis reduces the depth of penetration (Ref. 12). The tangential velocity component of the cone elements during collapse causes the jet to disperse. This is shown in Fig. 13 for a 1.375-inch, 45-degree, mild-steel cone. This effect increases with increasing apex angle. Hemispherical liners are not affected as much as conical liners (Ref. 26).

PENETRATION DATA

Figures 14 and 15 (reproduced from Ref. 25) give penetration data for concrete and homogeneous armor.

SHAPED-CHARGE DESIGNS

Different weapons that have been designed to use the shaped charge are illustrated in this section. These illustrations are intended to show what has been tried, but should not be assumed to be the best designs possible.

The 105-mm H.E.A.T. round fired statically could defeat 13 inches of mild steel. Rotation reduced this so much that a fin-stabilized round was desired. This round, with a muzzle velocity of 1,538 fps, could penetrate a 7-inch mild-steel plate at an angle of 48 degrees leaving an ample 1/2-inch by 3/4-inch hole, 10.5 inches in total length. There was some indication that the round was unstable in flight at transonic velocities. The 105-mm fin-stabilized H.E.A.T. round is illustrated in Fig. 16.

Figures 17, 18, 19, 20, 21, and 22 illustrate other designs using the shaped charge. Table 2 summarizes information on service round designs.

FURTHER PROPOSALS

FLUTED LINERS

Fluted liners have been used in an attempt to correct the bad effects of rotation. No firm design or design information is yet available on this liner, as it is still in the experimental stage. The work is being done by the Carnegie Institute of Technology.

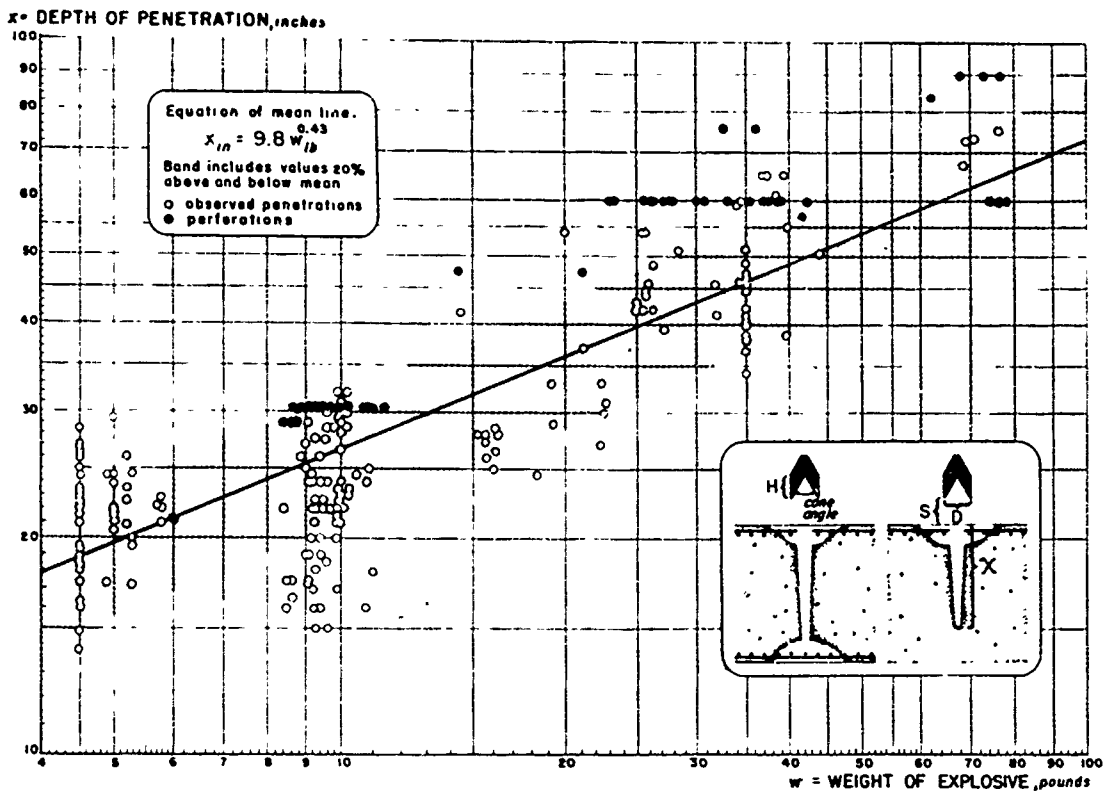

The graph shows depth of penetration produced in concrete by a cone-end charge placed with axis perpendicular to the slab face. The mean line was determined by a least squares reduction; shaded band includes values 20% above and below mean.

Because of scabbing on rear face (see inset sketches) perforation often results even when slab thickness is greater than the penetration depth that would result in massive concrete.

TYPE OF EXPLOSIVE: Effects are not greatly dependent on explosive type provided charge is thoroughly compact and adequately primed.

- | | | | | |
|----------------|--------------|------------------|-------------|---------------------|
| BEST - TNT/RDX | Plastic H.E. | GOOD - Pentolite | Nobel 808 | POOR - 60/40 Amatol |
| TNT/PETN | Cyclotol | TNT | Picric Acid | P. A. G. |
| TNT/CE | F.E. | Lyddite | Tetrytol | |

CONE LINING: Dependence on material and thickness is not great.

Materials: BEST - Presse; steel. Forms large slug which may stick in hole, especially if cone angle is less than about 70°; may thus impair insertion of demolition charge.
 GOOD - Glass. Hole somewhat shallower but of larger volume than with steel. Less debris is left in hole. Cast brass and cast manganese bronze also good.

Thickness: Various thicknesses used. Experiments indicate optimum value of about 0.1 inch (steel) for a charge of 6-inch diameter, and weighing approximately 10 lbs.

CONE ANGLE: Not extremely critical, but 60° to 80° usually adopted.

LENGTH-DIAMETER RATIO: Values of H/D (see sketches) between 1/2 and 1 are recommended.

STAND-OFF DISTANCE: The optimum stand-off, S, appears to be between about 1/2 and 1 1/2 diameters.

CONCRETE STRENGTH: In general, slightly larger but not deeper holes result in softer concrete.

PILLBOX TESTS: Trials indicate that a 75-lb. charge will defeat a 5-ft. thick pillbox wall and throw scab capable of lethal or incapacitating effects on any occupants.

DATA FROM EXPERIMENTS BY U.S. ENGINEER BOARD AND BY BRITISH MINISTRY OF SUPPLY

May 1944

Fig. 14. Penetration of Concrete by Detonation of Cone-End Charges (Reproduced From p. 416 of Ref. 25).

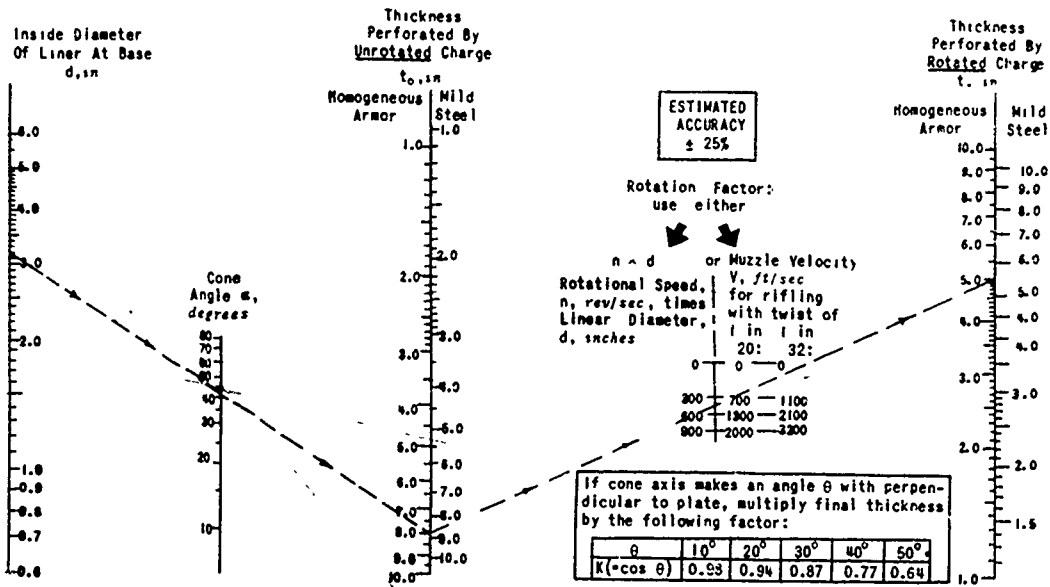

EXAMPLE: At normal incidence, an HEAT 105mm M67 having a muzzle velocity of 950 ft/sec and a twist of 1 in 20 will perforate about 5 in of armor, as shown by the index lines. At 30°, the performance will be about $5 \times 0.87 = 4.3$ in

The nomogram gives thickness of homogeneous armor perforated by Munroe jets from cone-end hollow charge projected weapons. The underlying empirical equation, deduced from performance records on actual weapons is

$$t = \frac{0.89 d \cos \theta}{\sin(a/2)} f(nd)$$

where $f(nd) = 1.0, 0.69, 0.57, 0.48$, for $nd = 0, 300, 600, 900$ r.e.s. in respectively. (see notation on nomogram.)

Factors such as thickness and material of liner, type and density of explosive, confinement of charge, stand-off distance, etc. are not included in the relation, although changes in these quantities are responsible for some variation in observed results. With the empirical relation used, scatter in the data precludes making a distinction between depth of penetration in massive plate and thickness of plate perforated. Thus the present relation will be useful in estimating performance of any weapon designed according to reasonable practice, but should be considered a rough guide to be used only in the absence of experimental data.

Basic data are mainly for projectiles having steel liners and filled Cyclotol or Pentolite. Explosives combining high power with high rate of detonation give greatest target damage. As the equation above shows, rotated projectiles generally form shallower craters; however, these are likely to be wider than the craters due to static detonation.

PERFORMANCE OF PARTICULAR WEAPONS:

| Weapon | Thickness of Armor Perforated, in (normal incidence) |
|----------------------------------|--|
| US - HEAT M6A3 (Bazooka) | 5.3 |
| Grenade M9A1 | 4.0 |
| HEAT 57mm T-20 E-2 | 3 |
| HEAT 75mm M66 | 3.5 |
| HEAT 105mm M67 | 4.8 |
| Br - PIAT | 3.8 |
| HEAT 3.7-in & 96mm | 5.0 |
| Ger - Panzerfaust (30, 60 & 100) | 8.0 |
| Panzerschreck (Ger. Bazooka) | 6.5 |
| Jap - A.T. Conical Hand Grenade | 2.8 |
| A.P. Rifle Grenade | 2 |

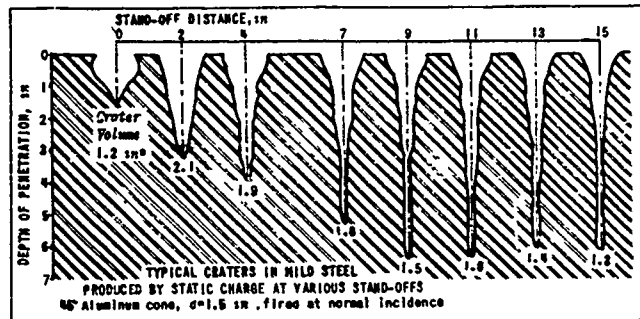
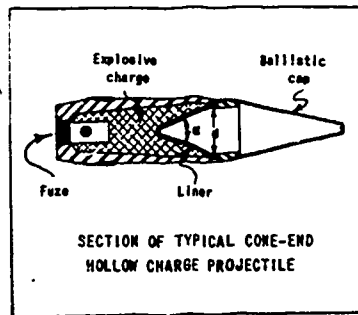

Ref: OTB-12f (OSRD-535of)
August 1945

Fig. 15. Perforation of Homogeneous Armor by Weapons With Cone-End Charges (Reproduced From p. 417 of Ref. 25).

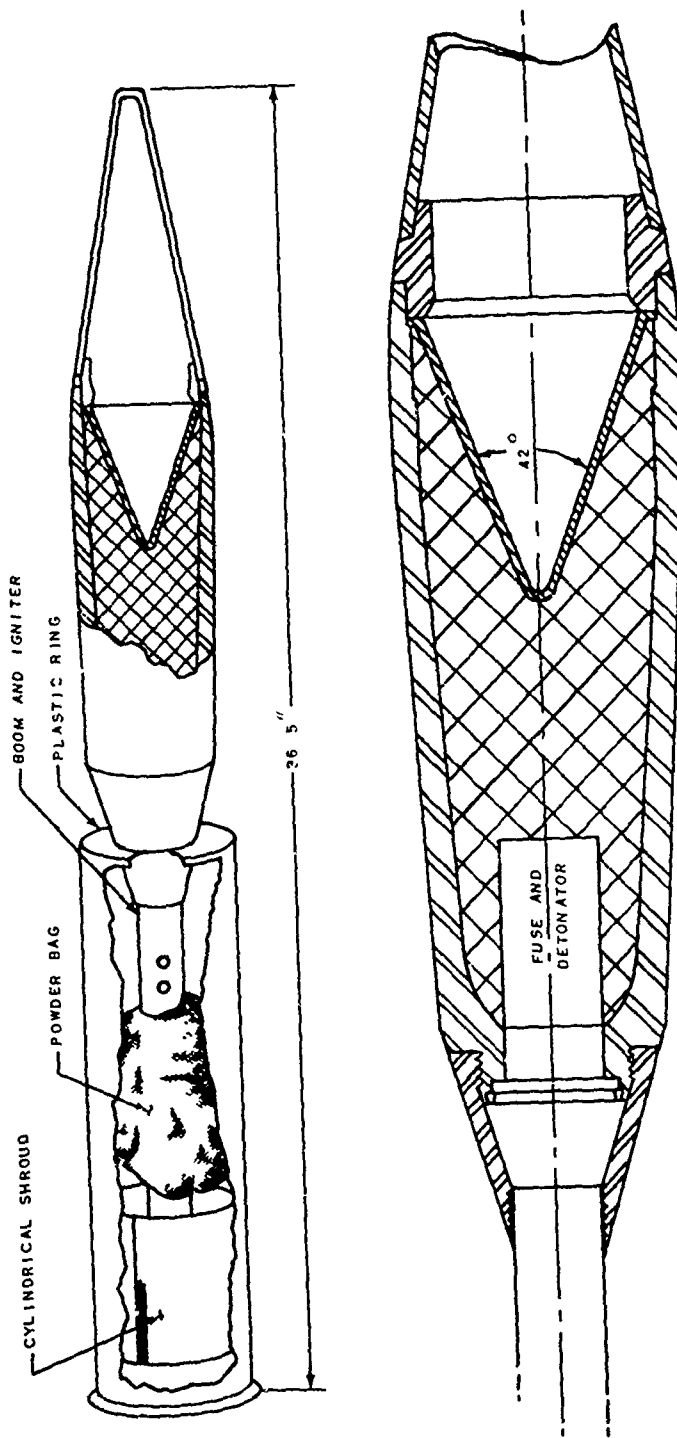

Fig. 16. 105-mm Howitzer Fin-Stabilized H.E.A.T. Round (Reproduced From Unnumbered Sketch Following p. 13 of Ref. 31).

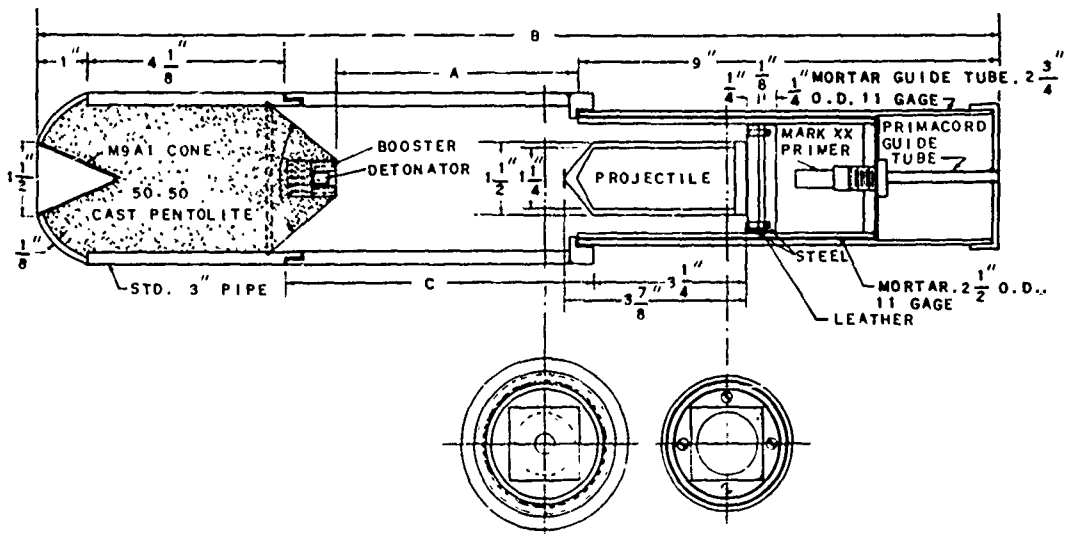

Fig. 17. Anti-Submarine Follow-through Bomb, Modified (Reproduced From Fig. III-5 of Ref. 29).

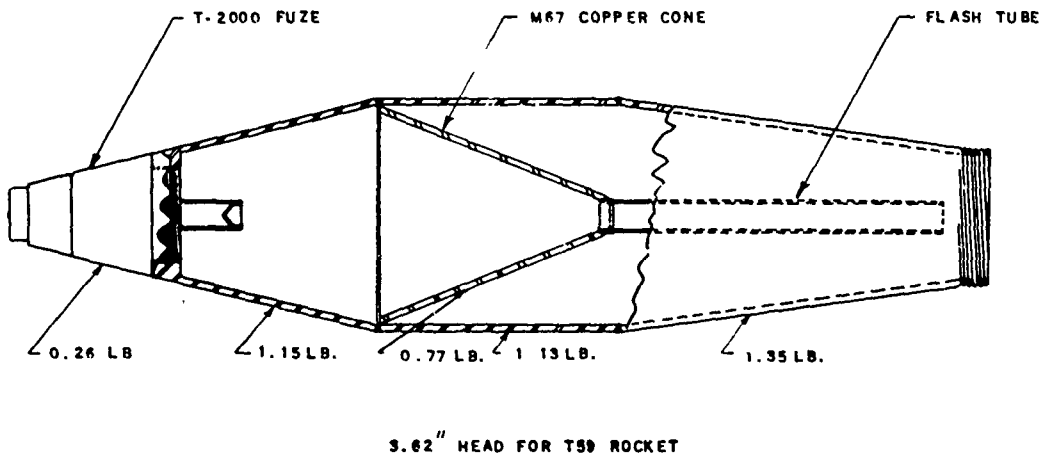

Fig. 18. 3.62" Head for T59 Rocket (Reproduced From Fig. 2 of Ref. 6).

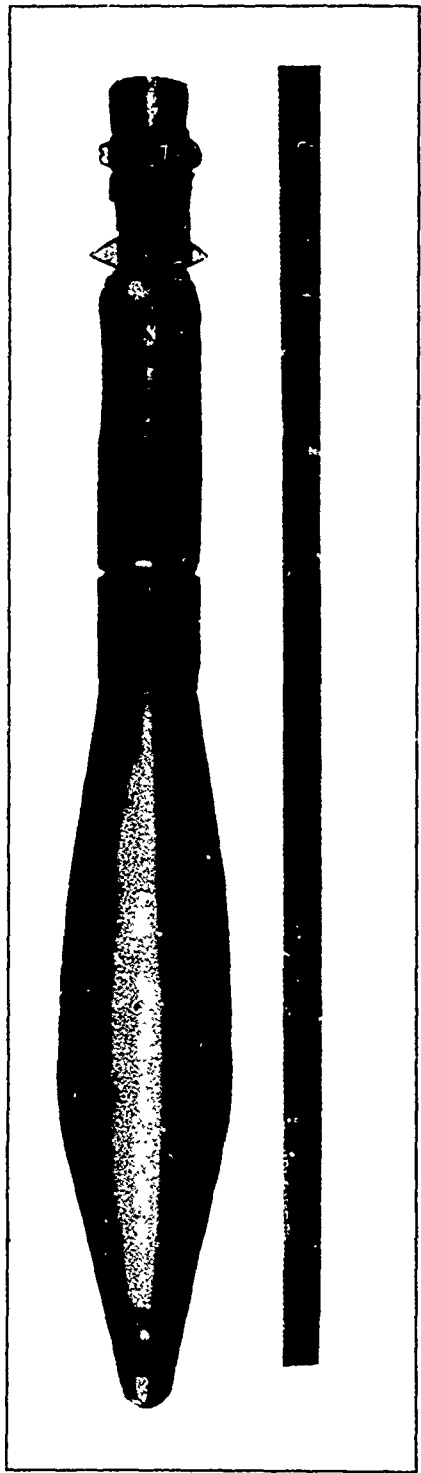

Fig. 19. 3.62" H.E.A.T. Rocket Head Bearing M67 Copper Cone With 2.36" T59 Motor
(Reproduced From Plate 1 of Ref. 6).



Fig. 20. Fastax Record of 3.62" H.E.A.T. Hound Striking Target at Normal Incidence.
Film speed, 6,500 frames per sec; projectile velocity, 250 fps; distance between inner
edges of tapes, 6 in.; depth of penetration, 16.4-in. mild steel. (Reproduced from
Plate 2 of Ref. 6.)

The German 88-MM. A. T. Rocket

DATA:

| | |
|-------------------------------|-----------------------------------|
| Total length | 25 9/16 in |
| Total weight | 7.3 lbs. |
| Propellant weight | 0.38 lbs. |
| Standoff distance | 6 in. |
| Maximum O D | 3 7/16 in |
| Cone angle (approx) | 48°. |
| Flash tube (approx) | 1/2 in diameter by 11/16 in. long |
| Explosive charge (cast) | 1.45 lb. Cyclotol (50/41). |

The German 88-mm. A. T. rocket, shown in figure 34 is believed to have been patterned after the American bazooka. This weapon is substantially larger than its American prototype and has a slightly greater range.

The cavity liner used in this weapon is of the combination type referred to earlier. It is believed that the Germans used a shallow apex angle for large slug formation and to reduce the standoff distance. The wider form near the base of the liner is most likely used to widen the hole produced in the target and thus provide for free passage of the slug formed by the apex of the liner.

The fuzing arrangement is characteristic of German cavity charge weapons. The base initiation of the charge is obtained by a flash tube which runs from the apex of the cavity lining to the base of the charge. Test firing of these rounds by the United States Army showed that the rocket motor throws a flame approximately 1 foot in diameter that envelops the forward portion of the launcher, thus compelling the operator to use gloves and mask or other shields.

This weapon has been modified to increase its range by altering its method of firing and mounting it on a light wheel carriage identified as the R. W. 43. It carries a rangefinder calibrated to 700 yards. The range is increased by closing the breech which introduces a certain amount of recoil, and substituting percussion for electric firing. The weapon forms a part of German paratroop equipment.

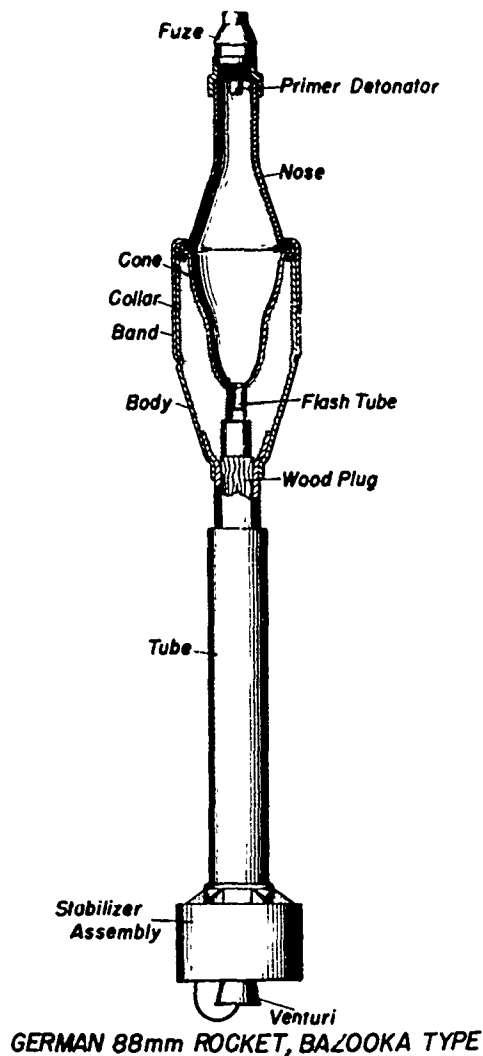

GERMAN 88mm ROCKET, BAZOOKA TYPE

Fig. 21. The German 88-mm A. T. Rocket (Reproduced From Fig. 34 and p. 24 of Ref. 20).

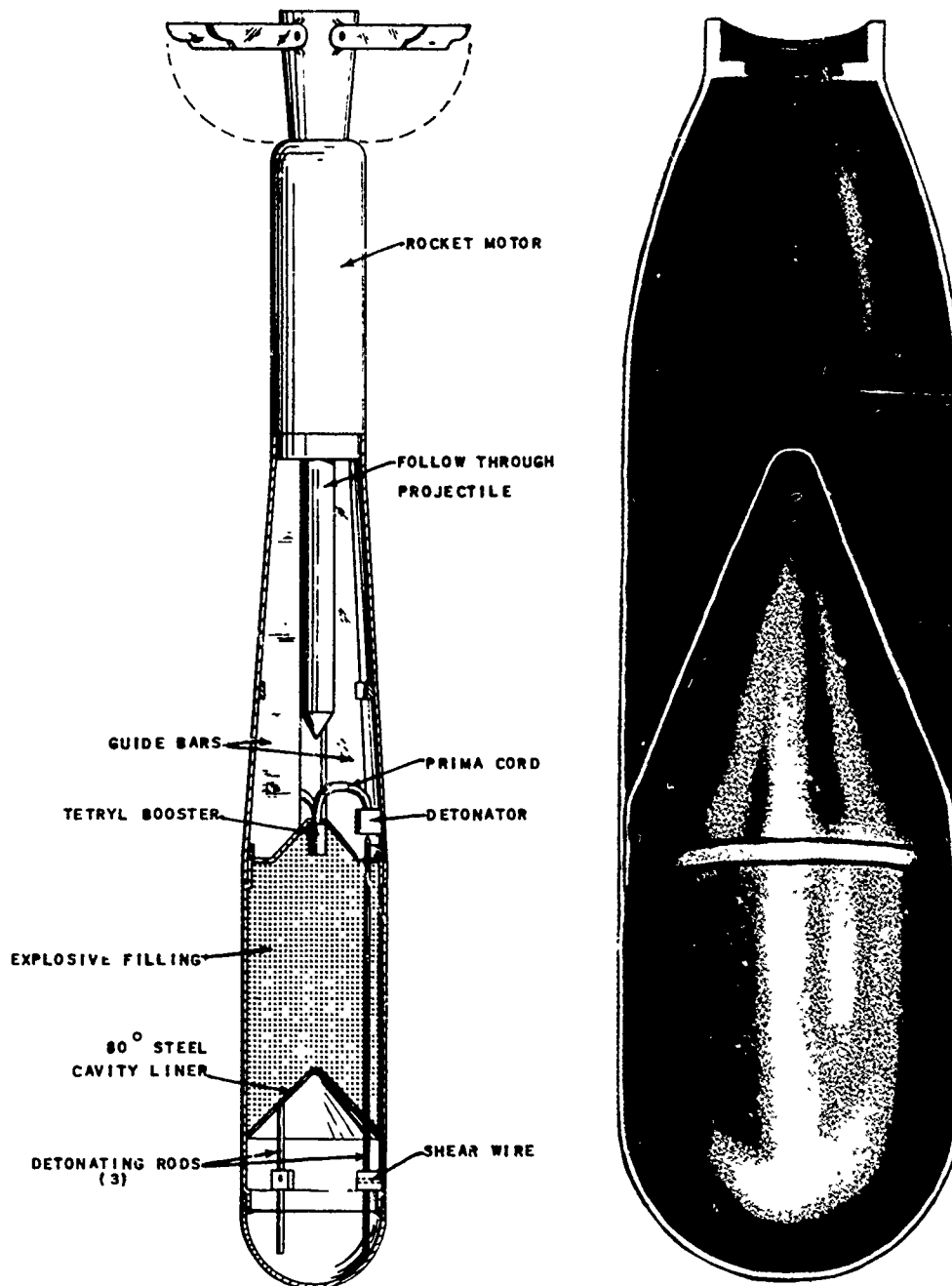

Fig. 22. Diagram and Sectional Head of U.S. Army Rocket H.E.A.T. T69 (7.2-in.). (Reproduced from Fig. 32 and 33, p. 23 of Ref. 30.)

TABLE 2
Service Round Designs

| ROUND | Cone Angle (deg) | Cone Thickness (in.) | Cone Diam. (D) (in.) | Cone Material | Explosive | Explosive Weight | Stand-off (Optimum) (in.) | Penetration Into Mild Steel (P) (in.) | K (P/D) | Remarks |
|--------------------------------------|------------------|----------------------|----------------------|---------------|-----------------|------------------|---------------------------|---------------------------------------|---------|--|
| Navy Cavity Chg. Mk 1 | 42½ | 0.06 | 2.25 | steel | plastic | 2/3 lb | 3 | 3.7 | 1.7 | Demolition Round |
| Navy Cavity Chg. Mk 2 | 80 | 0.030 | 1 | steel | plastic | 18 g | 2 | 1.4 | 1.4 | ditto |
| Navy Cavity Chg. Mk 3 | 80 | 0.090 | 3 | steel | plastic | 1.3 lb | 6 | 6.7 | 2.2 | ditto |
| Amy Rocket 7.2" H.E.A.T. T-69 | 48 | 0.15 | 7 | steel | PTX-2 | 25 lb | 7 | 26.2 | 3.7 | -- |
| Navy ASCB Antiaub. Bomb | 45 | 0.185 | 5.85 | steel | 60/40 Cycl. | 12.5 lb | -- | -- | -- | -- |
| German 88 MM AT Rocket | 48 | -- | 3 | -- | 59/41 Cycl. | 1.45 lb | 5.5 | (7.7) | 2.2 | -- |
| Navy Shaped Chg. Torpedo | 60 | 1/2 | 18 | steel | Torpex II | 520 lb | -- | -- | -- | -- |
| M9A1 Rifle Grenade | 42 | -- | 1 5/8 | -- | 50/50 Pentolite | -- | -- | 4.8 | 3 | -- |
| H.E.A.T. M6A3 2.6" (Bazooka) | -- | 0.062 | -- | -- | 50/50 Pentolite | -- | -- | 6.3 | -- | -- |
| H.E.A.T. 3.62" (Bazooka) | -- | -- | -- | -- | -- | -- | -- | 14.0 (approx.) | -- | -- |
| 105 MM Howitzer H.E.A.T. (Fin Stab.) | 42 | -- | -- | steel | -- | -- | -- | 10.5 | -- | -- |
| ASCFT Bomb | 45 | 0.037 | 1 1/2 | steel | Torpex II | 3 lb | -- | -- | -- | Opens large hole in ½-in. plate (penetration & blast effect) |

HEMISPHERICAL LINERS

V Hemispherical liners have been investigated for their adaptability to spinning projectiles and for use at long stand-off (3.5 to 4.5 charge diameters). The initial velocity of the particles is lower, axial tubes improve their performance, and they are not as sensitive to alignment as are cones. These charges produce larger hole volumes with an accompanying decrease in penetration.

TARGET DESIGN

Many different materials and geometries have been tried as defenses against shaped charges (Ref. 24). These include various chemicals, spaced armor (Ref. 9), plastic armor (Ref. 25), spikes (Ref. 25), and explosive-steel, explosive-glass laminated targets (Ref. 14).

PAPER FLASH-BACK TUBES

Recently, considerable work has been done on special shaped-charge designs at the Naval Ordnance Test Station. In this work, paper or bakelite tubes have been used in place of the metal flash-back tubes mentioned previously. Very promising results have been obtained.

REFERENCES

1. National Defense Research Committee. Summary Technical Report of Division 8, NDRC. Vol. 1. "The Preparation and Testing of Explosives." Washington, NDRC, 1946. (Summary Tech. Rept. Div. 8, Vol. 1) CONFIDENTIAL.
2. E. I. du Pont de Nemours and Co. Investigation of Cavity Effect, Sect. II. Gibbstown, N. J., Du Pont, 9 November 1942. (Report No. 5723-2) CONFIDENTIAL.
3. National Defense Research Committee. Progress Report on Improvements in the Performances of Cavity Charges, by M. A. Paul and J. F. Lemons. Bruceton, Pa., Explosives Research Laboratory, April 3, 1944. (OSRD No. 3443) CONFIDENTIAL.
4. _____. Division 8 Interim Report on Shaped Charges, June 15, 1944 to July 15, 1944, comp. by H. J. Fisher. Washington, NDRC, July 1944. (NDRC Report SC-11) CONFIDENTIAL.
5. _____. The Effects of Various Aberrations on the Performances of Cavity Charges. Washington, NDRC, 3 December 1945. (OSRD No. 5599) CONFIDENTIAL.
6. _____. Division 8 Interim Report on Shaped Charges, May 15, 1945 to June 15, 1945, comp. by H. J. Fisher. Washington, NDRC, May 1945. (NDRC Report SC-22) CONFIDENTIAL.
7. _____. Progress Report on the Effect of Unsymmetrical Cone Alignment on the Jet From a Cavity Charge, by M. A. Paul. Bruceton, Pa., Explosives Research Laboratory, August 5, 1943. (OSRD No. 1681) CONFIDENTIAL.
8. _____. Development of Anti-Sub Scatter Bomb. Washington, NDRC, November 1942. (NDRC Report CF-3) CONFIDENTIAL.
9. _____. Progress Report on Penetration of Steel Targets in Air by Small-Scale Cavity Charges, by M. A. Paul. Bruceton, Pa., Explosives Research Laboratory, September 29, 1943. (OSRD No. 1861) CONFIDENTIAL.
10. Ministry of Supply. Advisory Council on Scientific Research and Development, Shaped Charges Sub-Committee. A Formulation of Mr. Tuck's Conception of Munroe Jets, by G. I. Taylor. London, HMSO, March 1943. (Report No. A. C. 3734-SC 15) CONFIDENTIAL.
11. Ballistics Research Laboratory. Mathematical Jet Theory of Lined Hollow Charges, by G. Berkhoff. Aberdeen, Md., APG, June 1943. (Report 370) CONFIDENTIAL.
12. _____. Hollow Charge Anti Tank Projectiles, by G. Berkhoff. Aberdeen, Md., APG, February 1947. (Report 623) CONFIDENTIAL.

13. California Institute of Technology. Fundamentals of Shaped Charges, 17th Bimonthly Report. Pasadena, Calif., CIT, 30 April 1949. (CIT/ORD 20) CONFIDENTIAL.
14. _____. Fundamentals of Shaped Charges, 16th Bimonthly Report. Pasadena, Calif., CIT, 28 February 1949. (CIT/ORD 19) CONFIDENTIAL.
15. _____. Fundamentals of Shaped Charges, 20th Bimonthly Report. Pasadena, Calif., CIT, 31 October 1949. (CIT/ORD 23) CONFIDENTIAL.
16. Ballistics Research Laboratory. High Speed Radiographic Studies of Controlled Fragmentation. by L. B. Seely and J. C. Clark. Aberdeen, Md., APG, 25 September 1944. (APG/BRL 489) CONFIDENTIAL.
17. National Defense Research Committee. Division 8, Interim Report, August 15, 1943 to September 15, 1943, Shaped Charges. Washington, NDRC, September 1943. (NDRC Report SC-1) CONFIDENTIAL.
18. _____. Division 8 Interim Report on Shaped Charges, July 15, 1944 to August 15, 1944, comp. by H. J. Fisher. Washington, NDRC, August 1944. (NDRC Report SC 12) CONFIDENTIAL.
19. _____. Division 8 Interim Report, July 15, 1943 to August 15, 1943, on Controlled Fragmentation and Shaped Charges. Washington, NDRC, August 1943. (NDRC Report CF-12) CONFIDENTIAL.
20. E. I. du Pont de Nemours and Co. Investigation of Cavity Effect, Sect. IV. Wilmington, Del., January 1943. (Report No. 5723-4) CONFIDENTIAL.
21. National Defense Research Committee. Division 8 Interim Report on Shaped Charges, October 15, 1943 to November 15, 1943. Washington, NDRC, November 1943. (NDRC Report SC-3) CONFIDENTIAL.
22. Ballistics Research Laboratory. High Speed Radiographic Studies of Controlled Fragmentation Collapse of Hemispherical and Segmental Cavity Charge Liners, by R. O. Fleming, Jr., Aberdeen, Md., APG, March 1948. (Report 667) CONFIDENTIAL.
23. British Intelligence Objectives Subcommittee. Development of Hollow-Charge Work by Reinmetall, Borsig, Berlin, by H.L. Porter. London, B10S, 16 November 1948. (B10S Final Report No. 570) CONFIDENTIAL.
24. Ministry of Supply. Permanent Records of Research and Development. Defense of AFV's Against Attack by Hollow-Charge Weapons, by Major A. R. F. Martin, Royal Artillery. London, HMSO, December 1948. (MOS MONOGR 5.035) CONFIDENTIAL.

UNCLASSIFIED

CONFIDENTIAL

NAVORD REPORT 1248

25. National Defense Research Committee. Summary Technical Report of Division 2 NDRC, Vol. 1. Effects of Impact and Explosion. Washington, NDRC, 1946. (Summary Tech.Rept. Div. 2, Vol. 1) CONFIDENTIAL.
26. Ballistics Research Laboratory. The Effect of Rotation Upon the Explosive Collapse of Thin Metal Surfaces of Revolution, by J. S. Clark, and R. O. Fleming, Jr. Aberdeen, Md., APG, July 1948. (Report 671) CONFIDENTIAL.
27. National Defense Research Committee. Steel Target Penetration in Air by Small-Scale Cavity Charges. Washington, NDRC, 15 January 1946. (OSRD No. 5604) CONFIDENTIAL.
28. Office of Scientific Research and Development. A Compilation of Papers Presented at the Shaped Charge Symposium Sponsored Jointly by the Joint Army-Navy-NDRC Committee on Shaped Charges. Washington, OSRD, May 1945. (OSRD No. 5754) CONFIDENTIAL.
29. National Defense Research Committee. Division 8 Interim Report on Shaped Charges, April 15, 1944 to May 15, 1944, comp. by H. J. Fisher. Washington, NDRC, May 1944. (NDRC Report SC-9) CONFIDENTIAL.
30. Navy Department, Bureau of Ordnance. Applications of Lined Cavity Charges. Washington, BuOrd, 1 June 1946. (OP 1647) CONFIDENTIAL.
31. Ballistics Research Laboratory. Experiments With the 105-mm (Howitzer) Fin-Stabilized Hollow Charge Shell, by F. J. Zaroodny. Aberdeen, Md., APG, 15 September 1947. (APG/BRL Memo Rept. No. 457) CONFIDENTIAL.

UNCLASSIFIED

CONFIDENTIAL

UNCLASSIFIED

NAVORD REPORT 1248

CONFIDENTIAL

INITIAL DISTRIBUTION

- 15 Bureau of Ordnance
 - Ad6 (3)
- 2 Bureau of Aeronautics, Attn: AER-TD-4
- 5 Chief of Naval Operations
 - Deputy Chief (Air) (1)
 - Operations Evaluation Group (1)
- 2 Office of Naval Research
 - Code 463 (1)
 - Code 466 (1)
- 1 Commander Air Force, U. S. Pacific Fleet
- 1 Commander Air Force, U. S. Atlantic Fleet
- 1 Operational Development Force
- 1 Naval Proving Ground
- 1 Naval Ordnance Laboratory, Attn: Library
- 1 Naval Gun Factory, Attn: De790
- 2 Naval Torpedo Station, Newport, Attn: Design Officer
- 2 Naval Powder Factory
- 1 Naval Ordnance Plant, Indianapolis, Attn: Library
- 3 Naval Aviation Ordnance Test Station, Attn: Technical Development Department
- 1 Naval Research Laboratory, Attn: Code 2021
- 1 Naval Air Test Center, Attn: Aeronautical Publications Library
- 1 Naval Air Material Center
- 1 Bureau of Aeronautics General Representative, Western District
- 1 Bureau of Aeronautics Representative, Pasadena
- 1 Naval Liaison Officer, Air Proving Ground, Eglin AF Base
- 5 Office of the Chief of Ordnance
 - ORDTX-AR (1)
 - ORDTB (1)
 - ORDTS (1)
 - ORDTU (1)
 - CHORE (1)
- 4 Aberdeen Proving Ground, Attn: Ballistic Research Laboratories
- 1 Frankford Arsenal, Attn: Pitman-Dunn Laboratory
- 2 Picatinny Arsenal
- 1 Redstone Arsenal
- 5 U.S. Air Force, Directorate of Research & Development,
DCS/M, Attn: AFMPP

UNCLASSIFIED

CONFIDENTIAL

UNCLASSIFIED

~~CONFIDENTIAL~~

NAVORD REPORT 1248

- 7 Air Materiel Command, Wright-Patterson AF Base,
Attn: MCREAX6
 - 1 Holloman AF Base
 - 1 Air Materiel Armament Test Center, Air Proving Ground, Eglin
AF Base
 - 1 Los Angeles Air Materiel Command Engineering Field Office,
Attn: Officer-in-Charge
 - 1 National Bureau of Standards, Attn: Ordnance Development
Laboratory
 - 2 Applied Physics Laboratory, Johns Hopkins University
- 30 Shaped Charge Working Panel

UNCLASSIFIED

~~CONFIDENTIAL~~