

Part V  
Italian  
Underwater  
Ordnance

# MINE DISPOSAL HANDBOOK

## PART V

### ITALIAN UNDERWATER ORDNANCE

. . . . .

TABLE OF CONTENTS

PART V - ITALIAN UNDERWATER ORDNANCE

CHAPTER 1

Page

ITALIAN CONTACT MINES

Mine Chart (Table 1) .....	2
Introduction .....	3
Mine Type II .....	5
Mine Type IJ .....	7
Mine Type IK (IK Coloniale) .....	11
Mine Type IL .....	15
Mine Type IM .....	17
Mine Type IN .....	19
Mine Type IO .....	21
Mine Type IP .....	25

CHAPTER 2

ITALIAN TORPEDOES

Introduction .....	3
Warheads Types A, B and C .....	3
SIC Warhead .....	3
Standard Exploder .....	7
SIC Activator .....	11
SIC Circuit - Operation .....	15
Circling Torpedo .....	17
Circling Torpedo Exploders	
Impact-Direct Action Type .....	21
Impact-Inertia Type .....	21
Self-Destroying Type .....	23

CHAPTER 3

ITALIAN DEPTH CHARGES

Introduction .....	3
1927 Model Depth Charge .....	3
1936 Model Depth Charge .....	5
Pistols Type A and B .....	7
Boosters Type A and B .....	9
Booster Extender and Booster Release Mechanisms .....	9
Flooder Device .....	9
Tactical Depth Charge .....	11

CHAPTER 4

ITALIAN MISCELLANEOUS

Controlled Mine Type O .....	3
160/C. S. Depth Bomb .....	5
Fuzes for 160/C. S. Depth Bomb .....	5
Explosive Paravane .....	11
Explosive Motorboat .....	13

Contact  
Mines

# MINE DISPOSAL HANDBOOK

## PART V

### ITALIAN UNDERWATER ORDNANCE

#### CHAPTER I

#### ITALIAN CONTACT MINES

JUNE 1, 1945

CONFIDENTIAL

Mine Type	Italian Designation	Laid By	Charge Wt. (lb.)	Firing Methods	Dimensions		Depth Taking	Maximum Depth (ft.)	Total Weight in Air (lb.)	Remarks
					Dia. (in.)	Length (in.)				
II	Torpedine aep 125/1933	S/C	275	Six chemical horns	33	40	Plummet	990	488	
IJ	Torpedine aep 145/1935	S/C	320	Seven chemical horns	38	38	Plummet	191	685	
IK	Torpedine aep 200/1936	S/C	440	Nine chemical horns	40 1/2	40 1/2	Plummet	330 case	851	Known to have been fitted with acoustic unit.
IL	Torpedine aep 150/1935	Sub	260	Seven chemical horns	36	54	Explosive pawl	1650 anchor 330 case	Unknown	
IM	Torpedine A.M. 70/1916 Harle	S/C	170	Hydrostat valve	30	30	Plummet	330	Unknown	
IN	Aircraft Mine 70/1918	A/C	154	Mechanical	Unknown		Suspended from buoy	5	Unknown	Drifter
IO	Torpedine Beta	S/C or A/C	425	Inertia-impact	18	104	Drifter		780	Fitted with PSE and scuttling clock.
IP	Torpedine Tipo V	A/C	739	Antenna (Galvanic action)	18	98	Ground		1101	Fitted with PSE.

Introduction

1. Although more than sixty models and modifications of Italian mines are believed to exist, this chapter discusses only those which have been recovered or concerning which reasonably complete intelligence information is available. It is believed that the other types either are obsolete or never progressed beyond the design stage. It is not considered likely that types other than those treated herein will be encountered by field personnel.
2. Almost no generalizations can be drawn with respect to Italian mine design. Although some of the mine firing devices and accessories incorporate unique features in the field of mine design, it will be noted that the various mine types described herein (i.e., those believed to be in service) reflect British, French and German design techniques for the most part and present but few original features. The mines vary considerably both in appearance and in the depth-taking and firing methods employed.
3. Particular care should be exercised when dealing with the moored contact type of mine which carries horns on its lower hemisphere, provided that the horns are not fitted on brackets. The position of the horn relative to the vertical is such that gravity prevents the electrolyte from running down into a horn battery when the vial is crushed. For this reason, each such horn contains a gas-charged vial in addition to the electrolyte ampoule, the purpose of the vial being to force the electrolyte up into the horn battery. Should one of these horns be broken, danger to personnel exists in that acid may be sprayed in the surrounding area, even though the mine firing mechanism has been rendered safe.
4. P.S.E.'s will be found fitted to the tail cover plates of both the Mines Type IO and IP. These devices, however, provide little difficulty in RMS because, in each case, access to the mine case is readily obtained elsewhere.
5. The following precautions should generally be observed when dealing with Italian contact mines:
  - (a) Be particularly careful not to bend or damage the horns in any way. This is of particular importance since some Italian mines contain mechanical horn firing systems which operate on horn movement.
  - (b) Do not move or jar the mine except from a safe distance.
  - (c) Do not allow metallic objects to contact antennae or electrodes.
  - (d) Note that boosters and detonators are permanently married upon completion of arming.
  - (e) Note that the self-disarming devices depend upon spring tension and cannot be relied upon to operate as designed.

ITALIAN CONTACT MINES

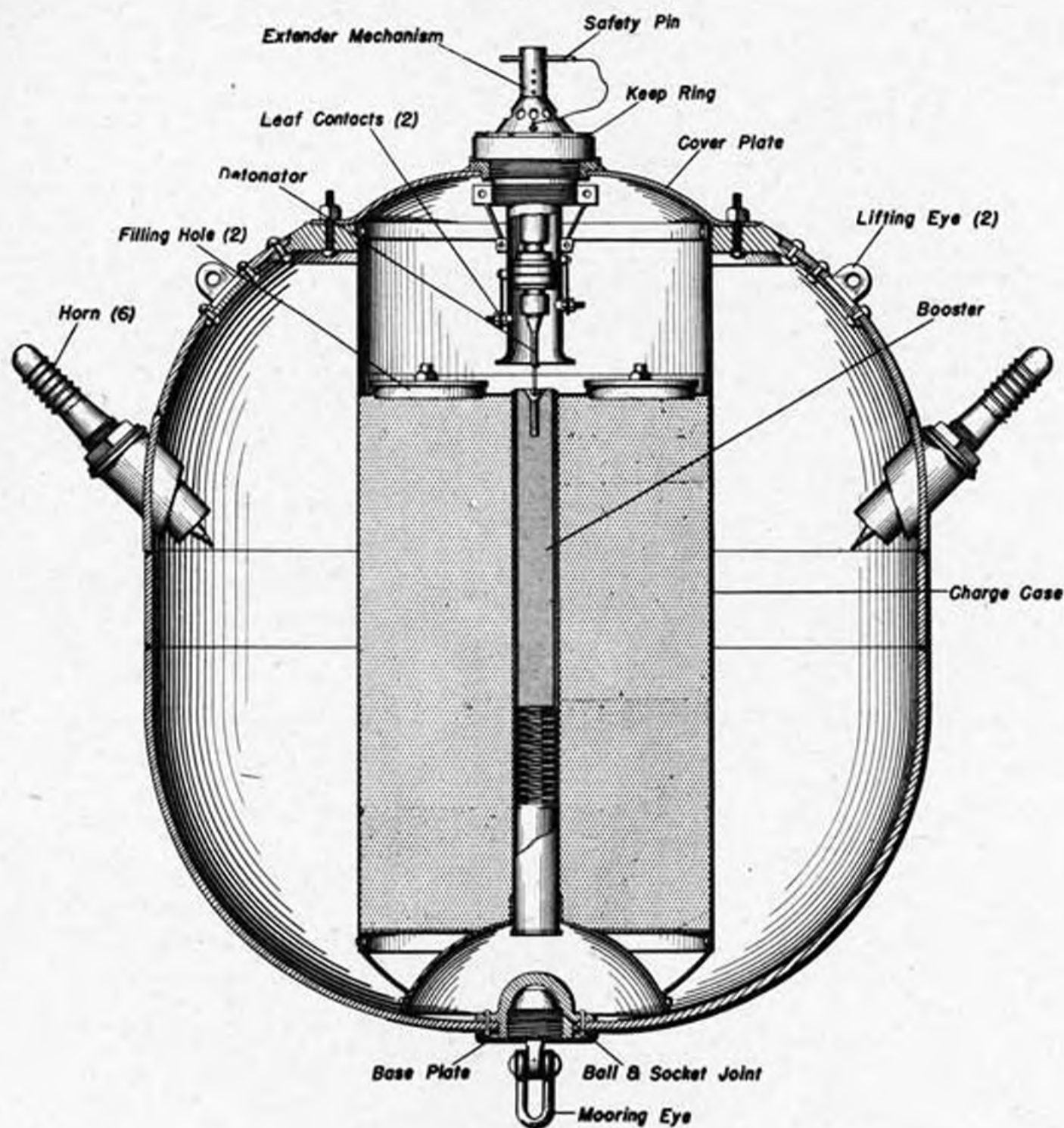

Fig. 1 - Mine Type II, Sectional View



Fig. 1a - Mine Type II, Extender Mechanism

Mine Type IIGeneral

1. Moored, contact, chemical horn mine, laid by surface craft.
2. Italian designation, "Torpedine aep 125/1933 Bollo".
3. Defensive mine, for use in maximum depth of water of 990 ft. against surface craft.

Description

## 1. Case

Shape	Two hemispheres, joined by a 5" cylindrical mid-section.
Color	Black
Material	Steel
Diameter	33"
Length	40"
Charge	275 lb. cast TNT
Total weight in air	487 lb.

## 2. External fittings

Horns	Six, equally spaced around upper hemisphere, 24" from center.
Cover plate	19" diam., in center of upper hemisphere, lap-fitted, secured by 18 bolts.
Extender mechanism	5" diam., in center of cover plate, secured by keep ring.
Base plate	5" diam., welded to center of lower hemisphere, fitted with ball and socket joint for securing mooring eye.
Name plate	16" from center of upper hemisphere.

Operation

1. Mine takes depth by plummet. Dissolution of a soluble plug allows the extender to operate upon application of the proper degree of hydrostatic pressure. When the extender operates, it moves the detonator carrier downward within its housing, performing the following arming functions:
  - (a) It bridges two leaf contacts in the housing, thereby arming the firing circuit.
  - (b) It separates two scissors arms, thereby freeing the spring-loaded booster to house over the detonator.
2. Standard chemical horn firing.
3. The only self-disarming device is the extender mechanism which is designed to disarm the mine by opening the firing circuit and separating the detonator and booster upon release of hydrostatic pressure.

Precautions

1. Check the extender spindle. Except in extreme emergency, do not attempt RMS if a safety pin cannot be inserted through the top of the spindle and spindle housing in the hole provided.

RMS

1. Remove the keep ring and extender mechanism.
2. Reach in the case, press back the spring clips and remove the booster.
3. Dispose of detonator, booster and charge.

ITALIAN CONTACT MINES

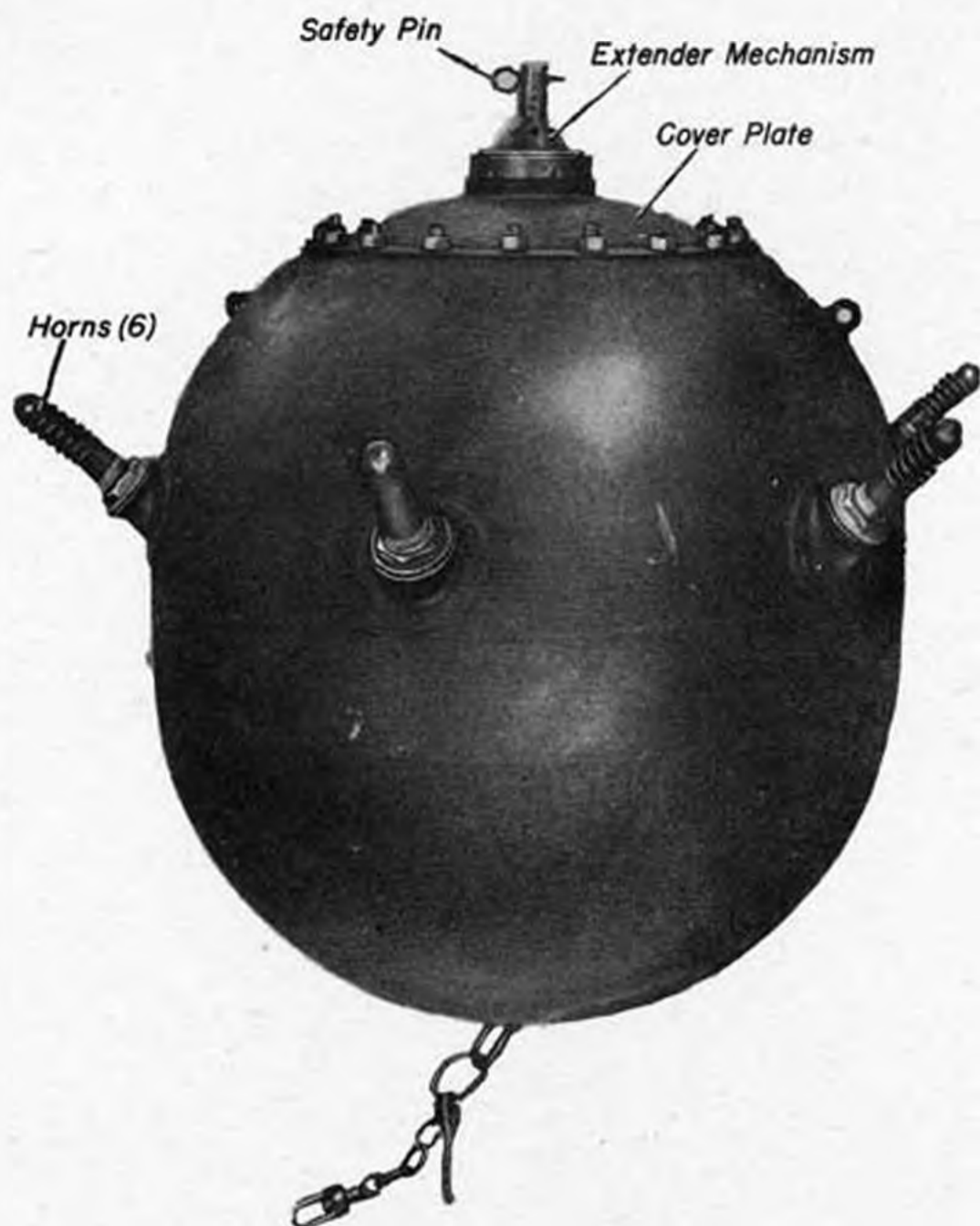

Fig. 2 - Mine Type II



Fig. 3 - Mine Type II, Floating

# ITALIAN CONTACT MINES

## Mine Type IJ

### General

1. Moored, contact, chemical horn mine, laid by surface craft.
2. Italian designation, "Torpedine aep 145/1935."
3. Defensive mine, for use in maximum depth of water of 191 ft. against surface craft or submarines.

### Description

#### 1. Case

Shape	Spherical
Color	Black
Material	Steel
Diameter	38"
Charge	320 lb. cast TNT with TNT booster.
Total weight in air	685 lb.

#### 2. External fittings

Horns	Seven; four equally spaced around upper hemisphere, 19" from center; one in center of upper hemisphere; two, 90° apart on lower hemisphere, 15" from center.
Base plate	16" diam., in center of lower hemisphere, lap-fitted, secured by 18 bolts. Fitted with straight shank mooring spindle, soluble plug fitting and detonator strongback and set screw.
Lifting eyes	Two, 90° apart on upper hemisphere, 8" and 26" respectively from center.
Anchor securing lugs	Three; two on lower hemisphere, 13" from center; one on upper hemisphere, 24" from center.
Name plate	On lower hemisphere, between horns, 23" from center.

### Operation

1. Mine takes depth by plummet. Dissolution of a soluble plug permits mooring tension to pull out the mooring spindle, closing the mooring safety switch, tripping the booster release lever and the mine is armed.
2. Standard chemical horn firing.
3. The only self-disarming device is the mooring safety switch which is designed to disarm the mine by opening the firing circuit upon release of mooring tension.

### Precautions

1. Check the mooring spindle. Except in extreme emergency, do not attempt RMS if a safety pin cannot be inserted in the hole provided.

### RMS

1. Unscrew the set screw in the center of the detonator strongback until the seal is broken and the detonator carrier starts to withdraw.
2. Remove the set screw and swing the strongback clear.
3. Remove the detonator carrier.
4. Remove the base plate; the booster will follow the base plate.
5. Dispose of detonator, booster and charge.

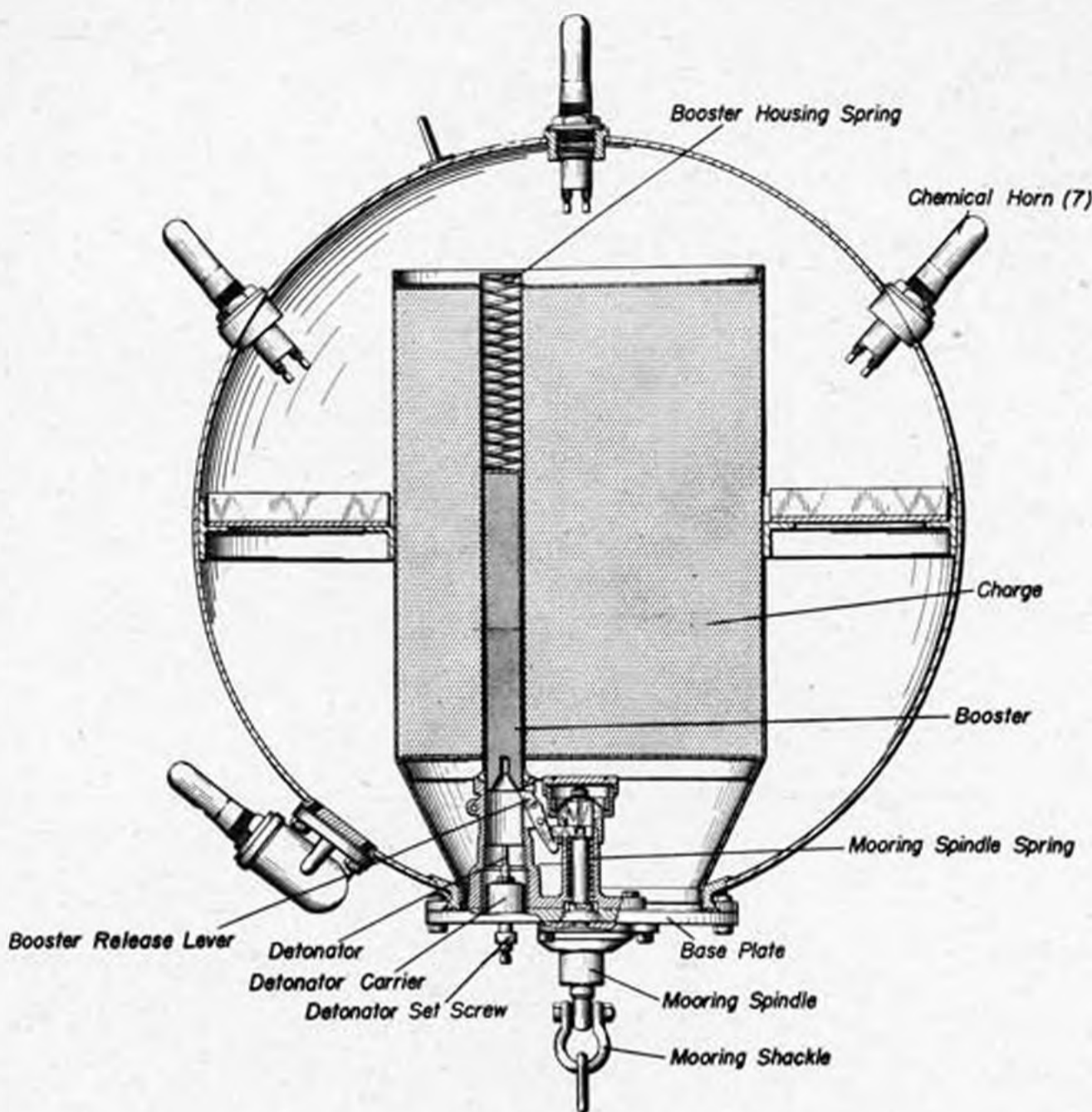

Fig. 4- Mine Type IJ, Sectional View

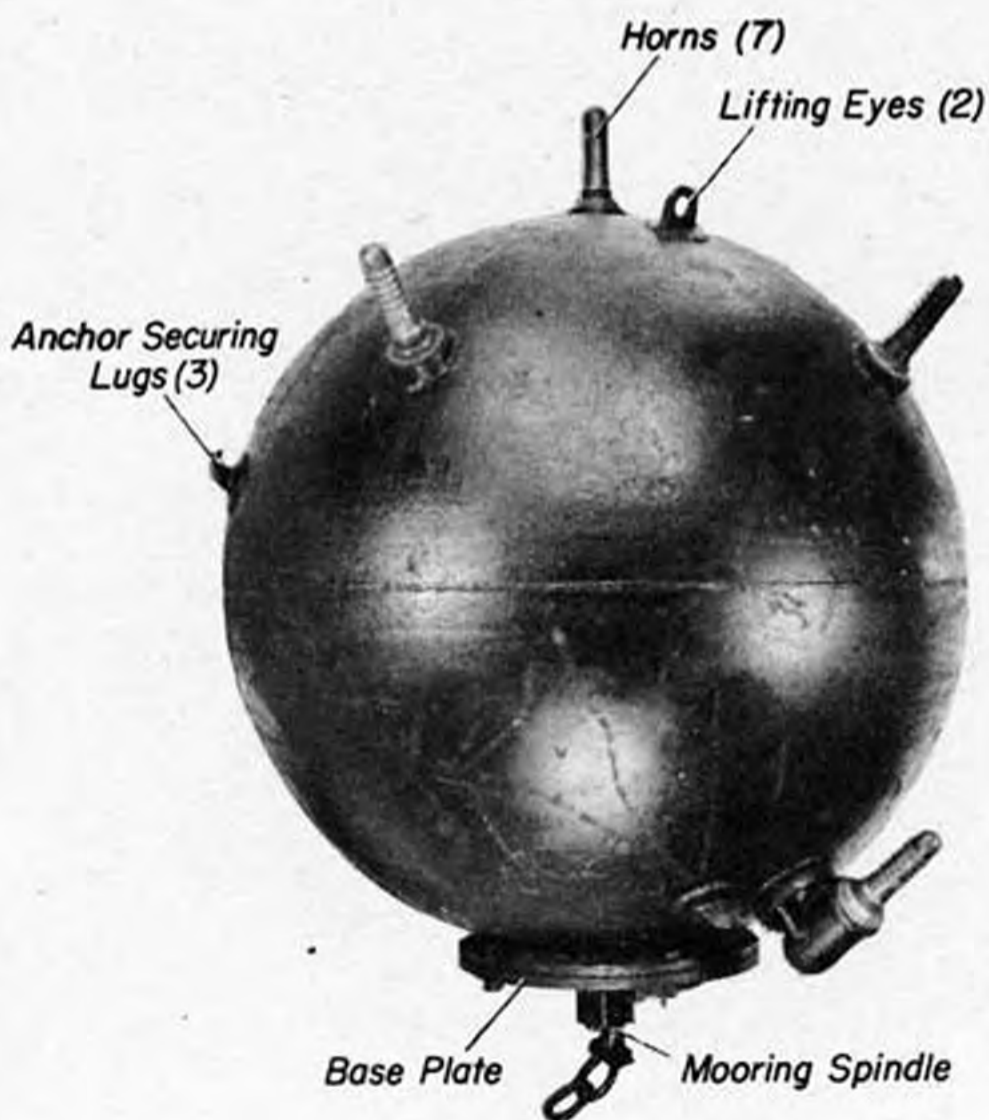

Fig. 5- Mine Type IJ

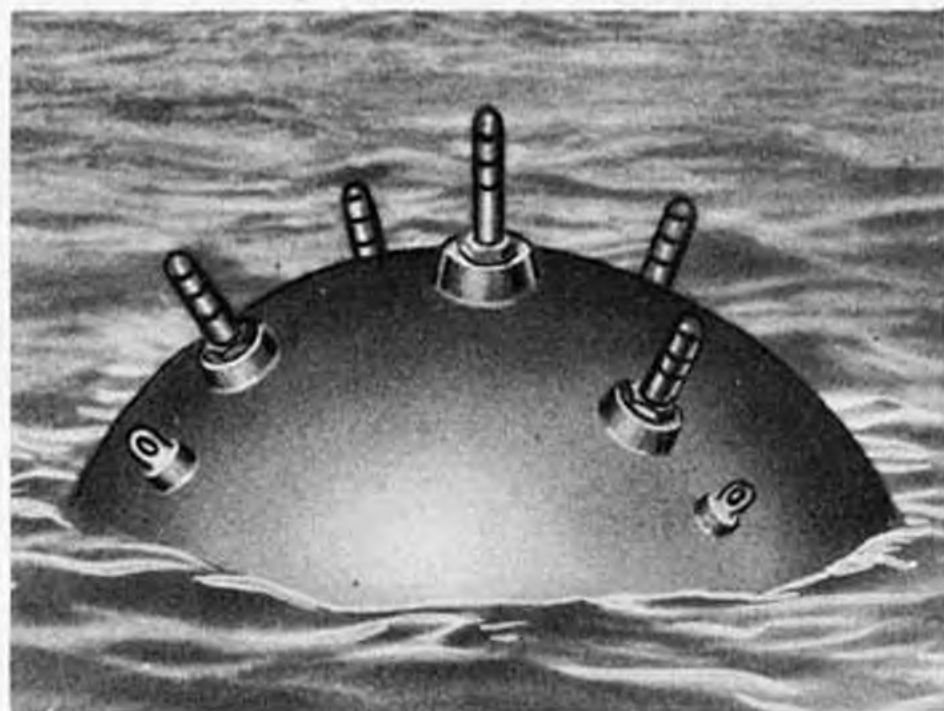

Fig. 6 - Mine Type IJ, Floating

Fig. 7 - Mine Type IJ, Base Plate, External View

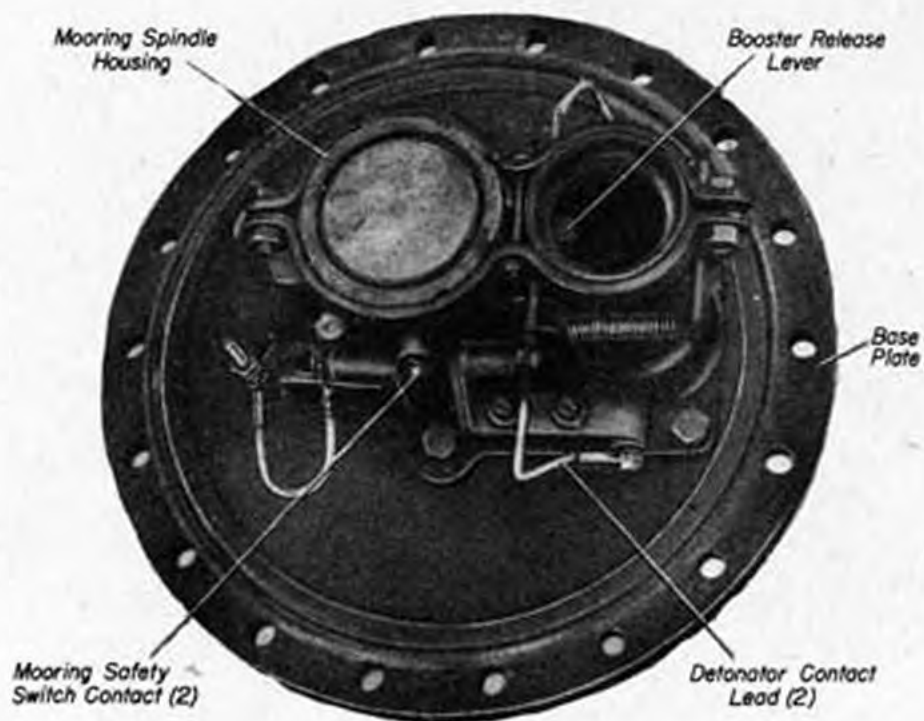
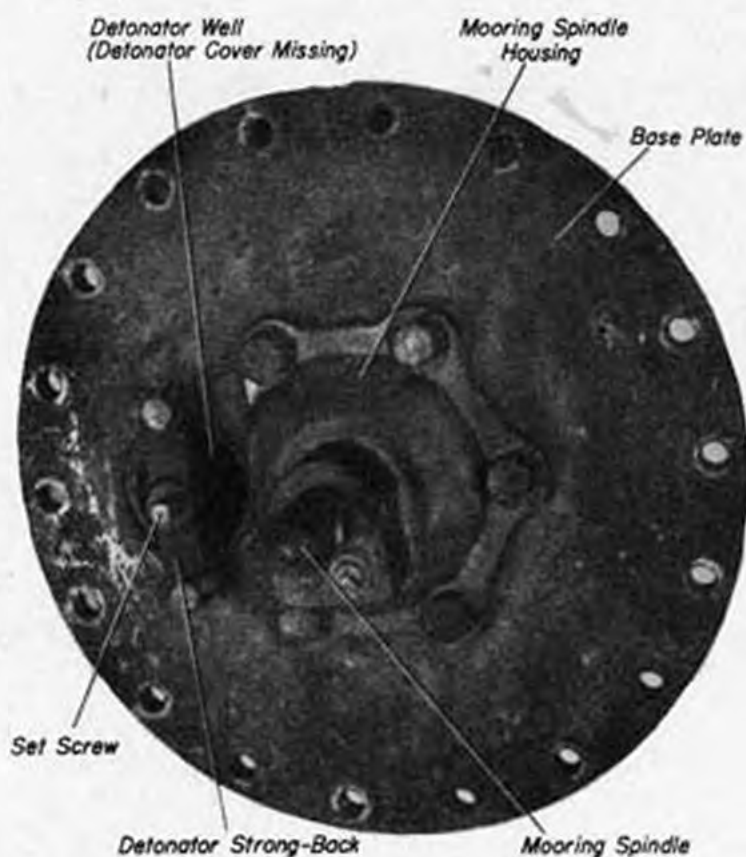

Fig. 8 - Mine Type IJ, Base Plate, Internal View

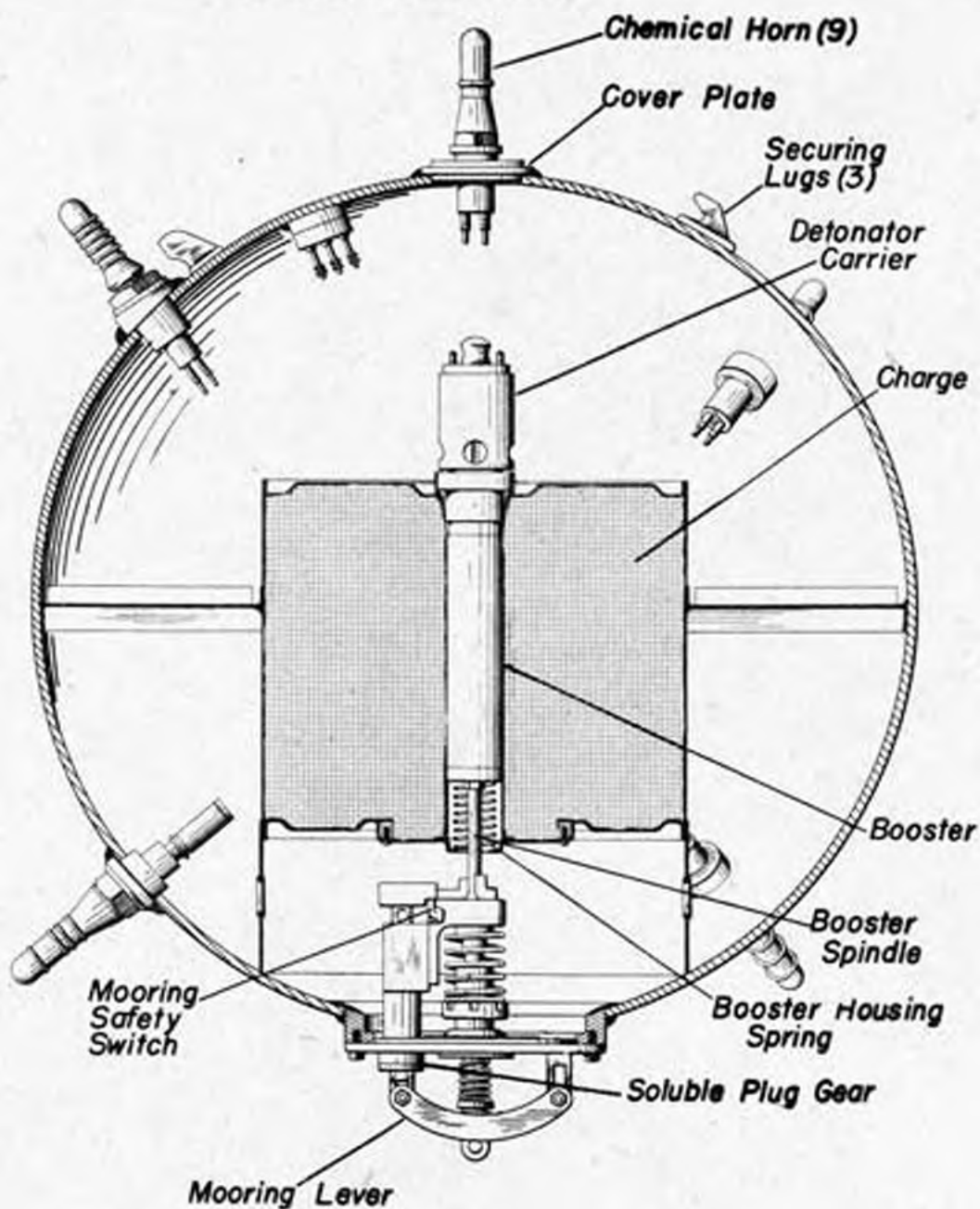

Fig. 9 - Mine Type IK, Sectional View

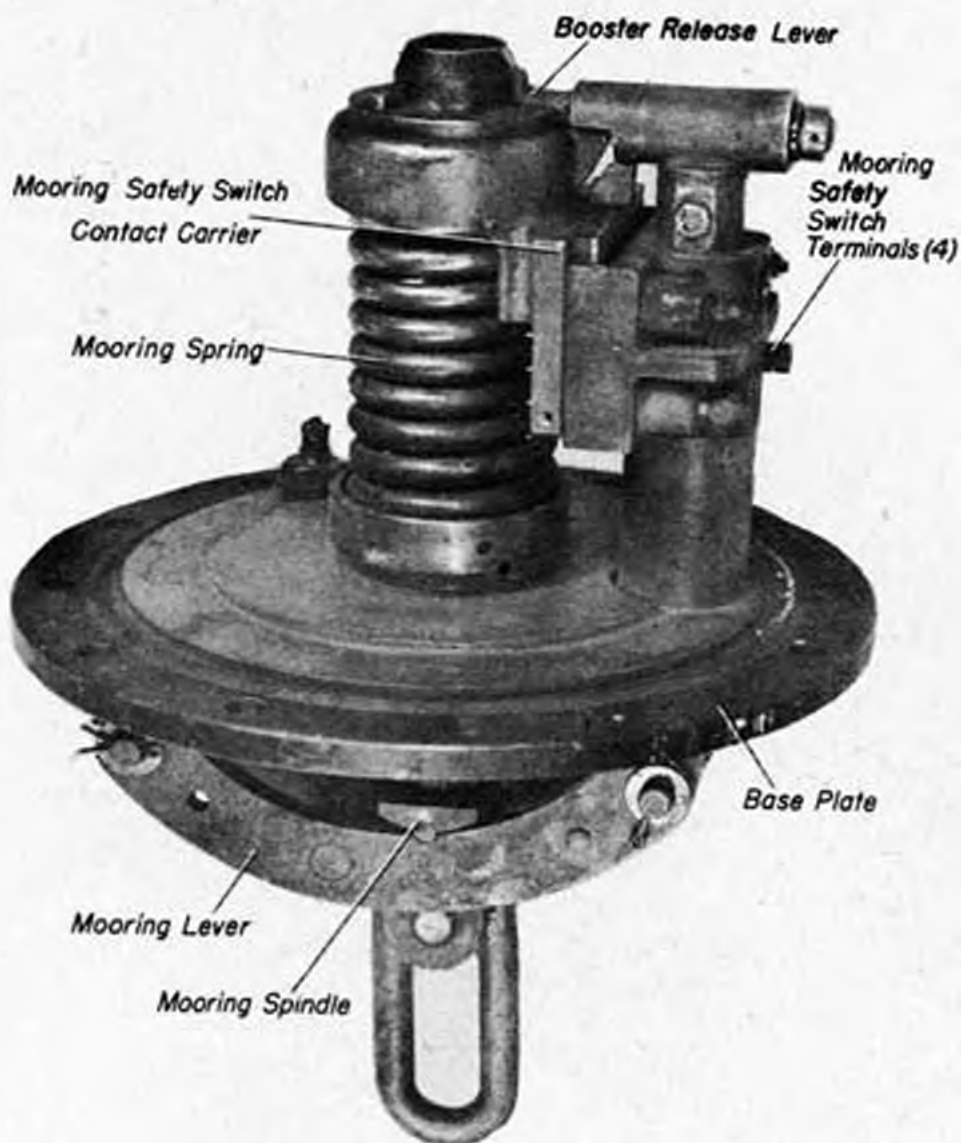

Fig. 10 - Mine Type IK, Base Plate

Mine Type IK (IK Colonial)General

1. Moored, contact, chemical horn mine, laid by surface craft. May be fitted with upper antenna.
2. Italian designation, "Torpedine sep 200/1936."
3. Defensive mine, for use in maximum depth of water of 330 ft. against surface craft.
4. This mine has been recovered with an acoustic unit fitted in place of the horn on the top cover plate. However, no details of acoustic operation are known.

Description

## 1. Case

Shape	Spherical
Color	Black
Material	Steel
Diameter	40 1/2"
Charge	440 lb. cast TNT with pressed TNT booster.
Total weight in air	851 lb.

## 2. External fittings

Horns	Nine; four, equally spaced around upper hemisphere, 21" from center, bosses painted red; one in center of upper hemisphere, boss painted blue; four equally spaced around lower hemisphere, 19" from center, bosses painted green.
Cover plate	10" diam., in center of upper hemisphere, lap-fitted, secured by eight bolts. Fitted with horn in center.
Base plate	12" diam., in center of lower hemisphere, lap-fitted, secured by 12 bolts. Fitted with mooring lever, soluble plug gear and antenna stuffing box.
Lifting eyes	Four; two, 180° apart on upper hemisphere, 19" from center; two, 180° apart on lower hemisphere, 19" from center.
Securing lugs	Three; two on upper hemisphere, 120° apart, 19" and 38" respectively from center; one on lower hemisphere, 11" from center.
Support legs	Three, forming a triangle whose base is 15" and whose center is 35" from center of lower hemisphere.
Name plate	12" from center of lower hemisphere.

## 3. The Mine Type IK Colonial differs from Mine Type IK as follows:

- (a) Its Italian designation is "Torpedine Coloniale sep 125/1938."
- (b) Its charge is 275 lb.

Operation

1. Mine takes depth by plummet. Dissolution of a soluble plug allows mooring tension to pull out the mooring lever, closing the mooring safety switch, tripping the booster release lever and the mine is armed.
2. Standard chemical horn firing.

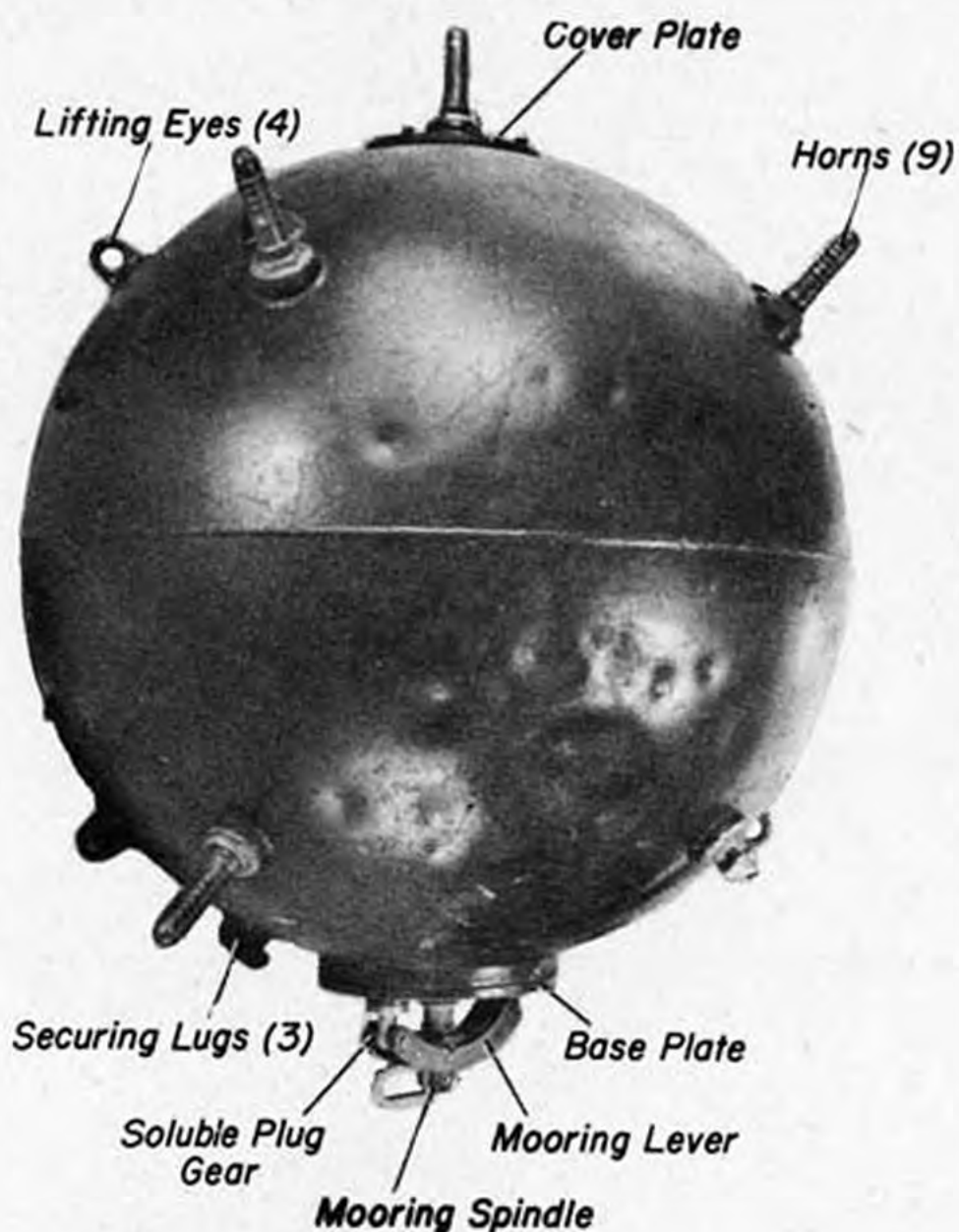

Fig. 11 - Mine Type IK

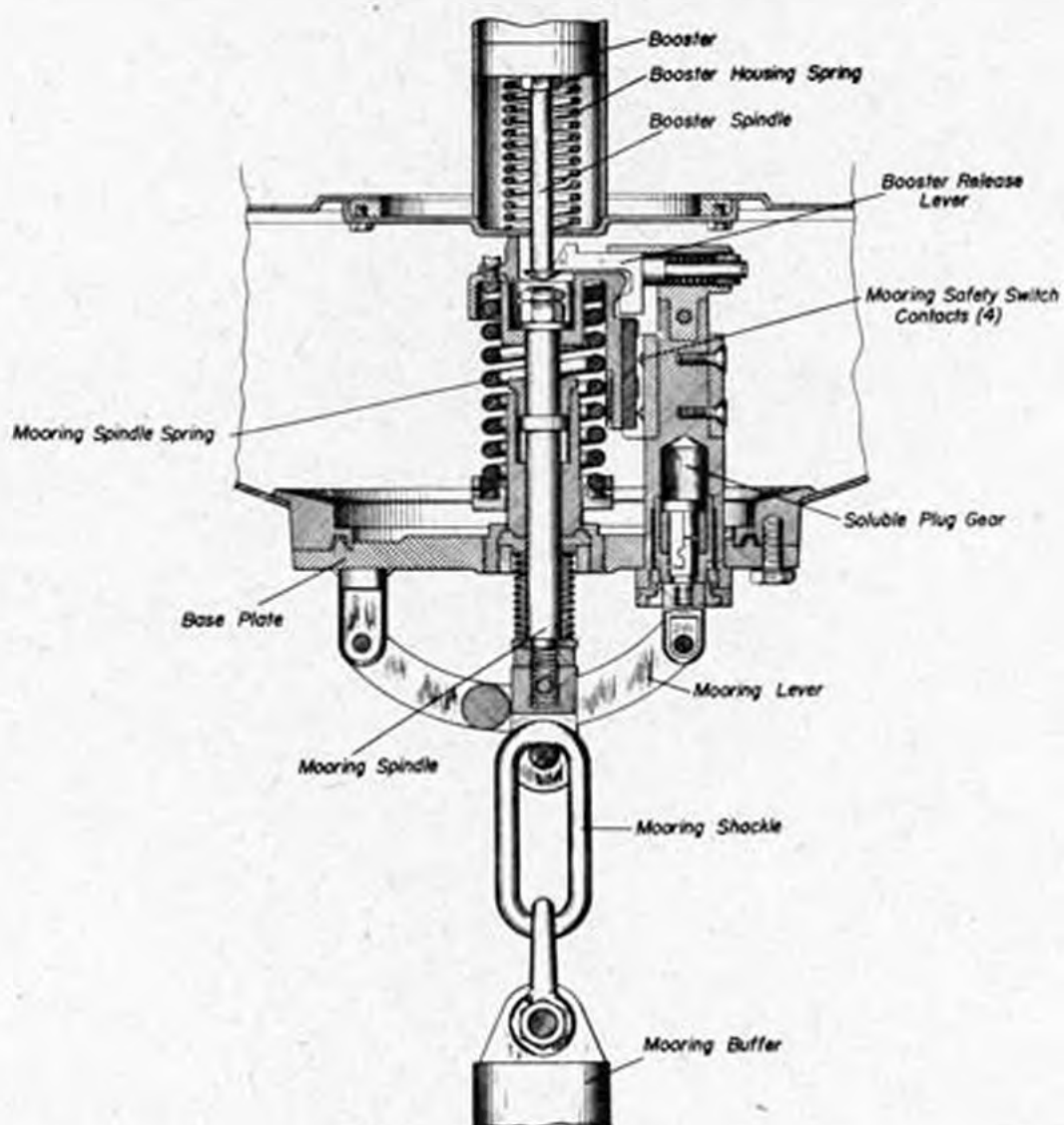

Fig. 12 - Mine Type IK, Base Plate,  
Showing Booster Release Mechanism, Sectional View

(Mine Type IK (IK Colonial), (Cont'd.))

3. The only self-disarming device is the mooring safety switch which is designed to disarm the mine by opening the firing circuit upon release of mooring tension.

Precautions

1. Keep all necessary noise to a minimum. The mine is known to have been fitted with an acoustic unit.
2. Check the mooring spindle. Except in extreme emergency, do not attempt RMS unless the bellows around the lower portion of the mooring spindle has retracted completely. The condition of the bellows may be ascertained by cutting its rubber diaphragm housing.

RMS

1. Remove the cover plate.
2. Compress the spring clips and remove the detonator lead plug.
3. Break the bayonet joint and remove the detonator carrier. The spring-loaded booster will follow it out.
4. Dispose of detonator, booster and charge.

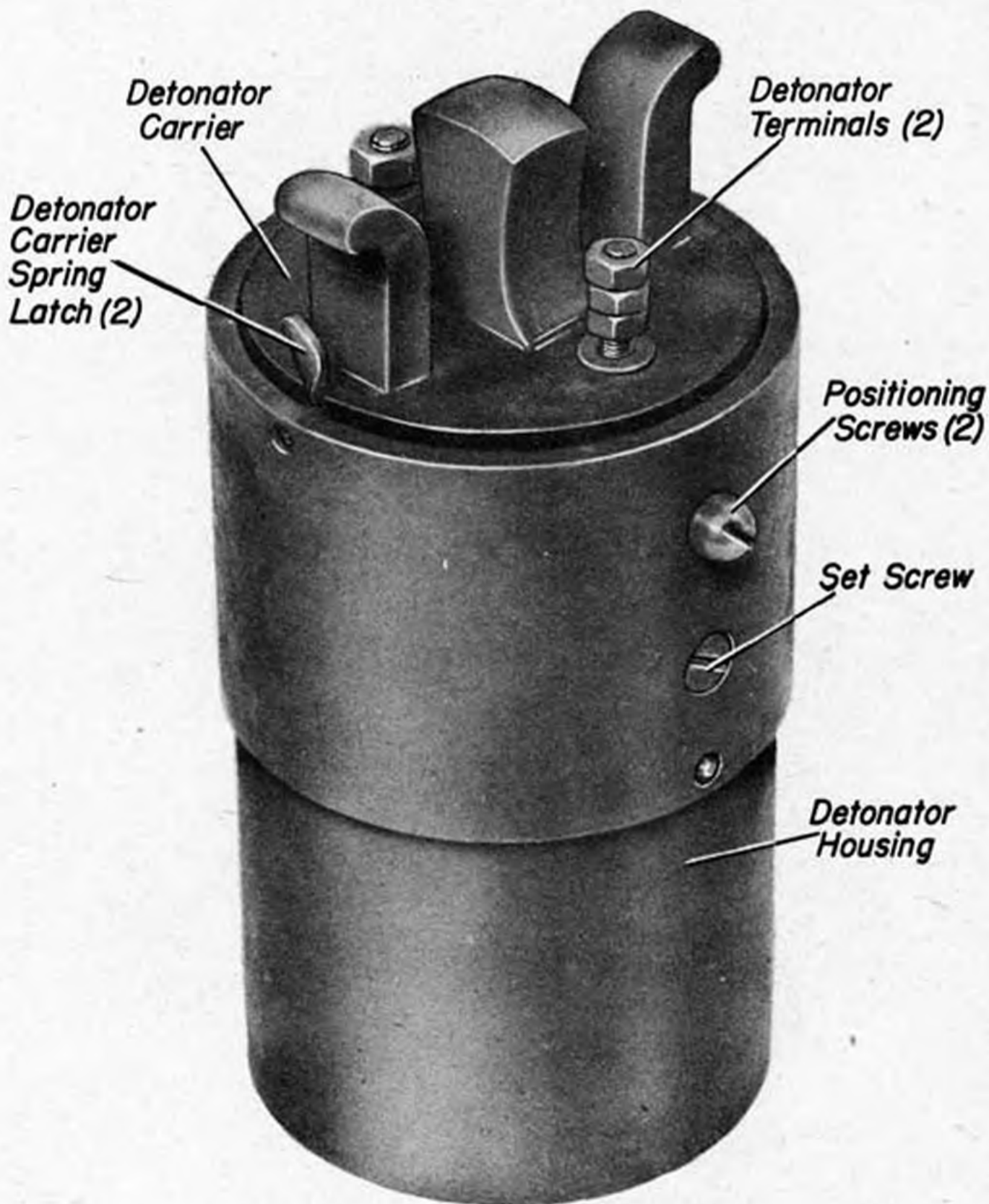

Fig. 13 - Mine Type IK, Detonator Carrier and Housing

ITALIAN CONTACT MINES

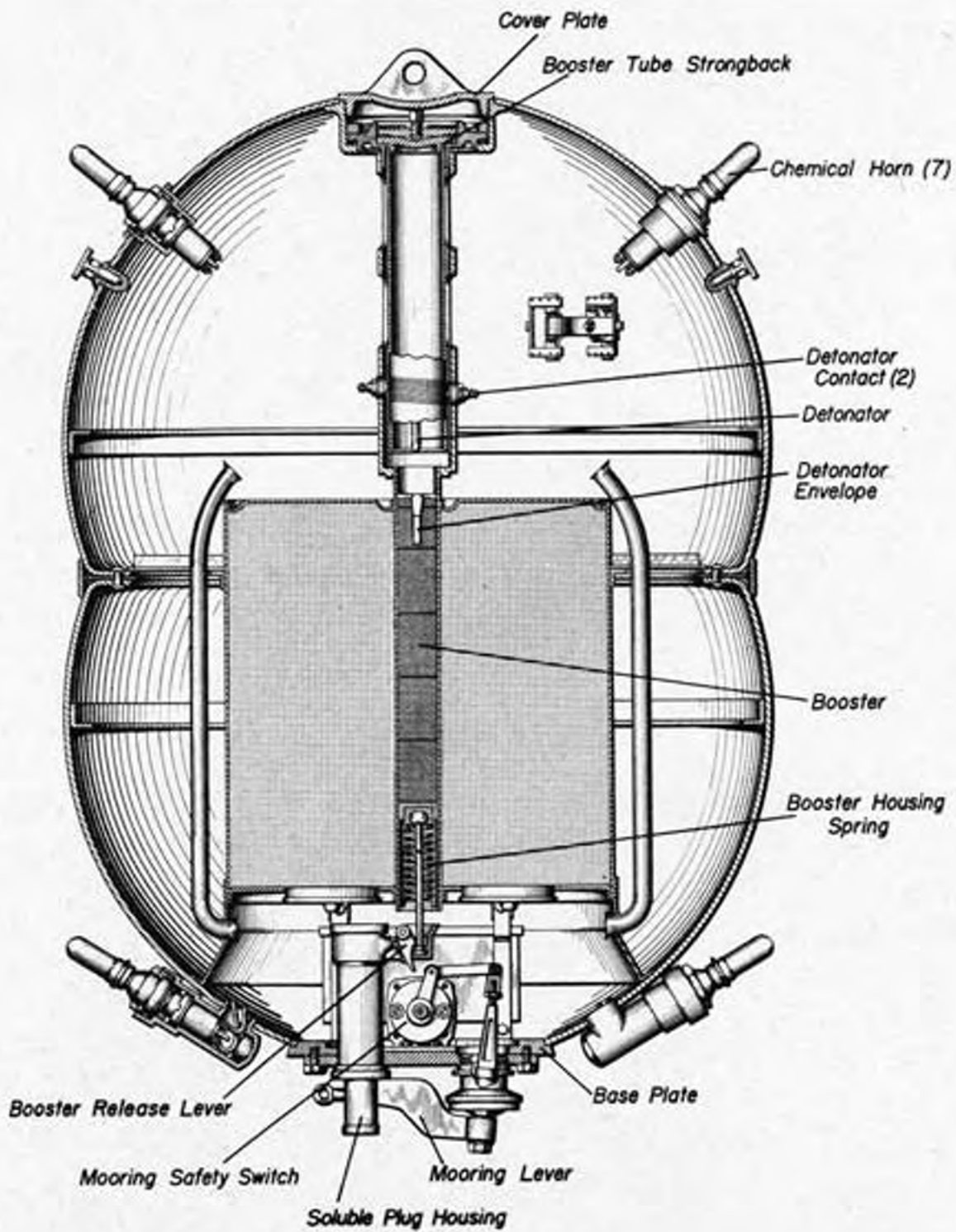

Fig. 14 - Mine Type IL, Sectional View

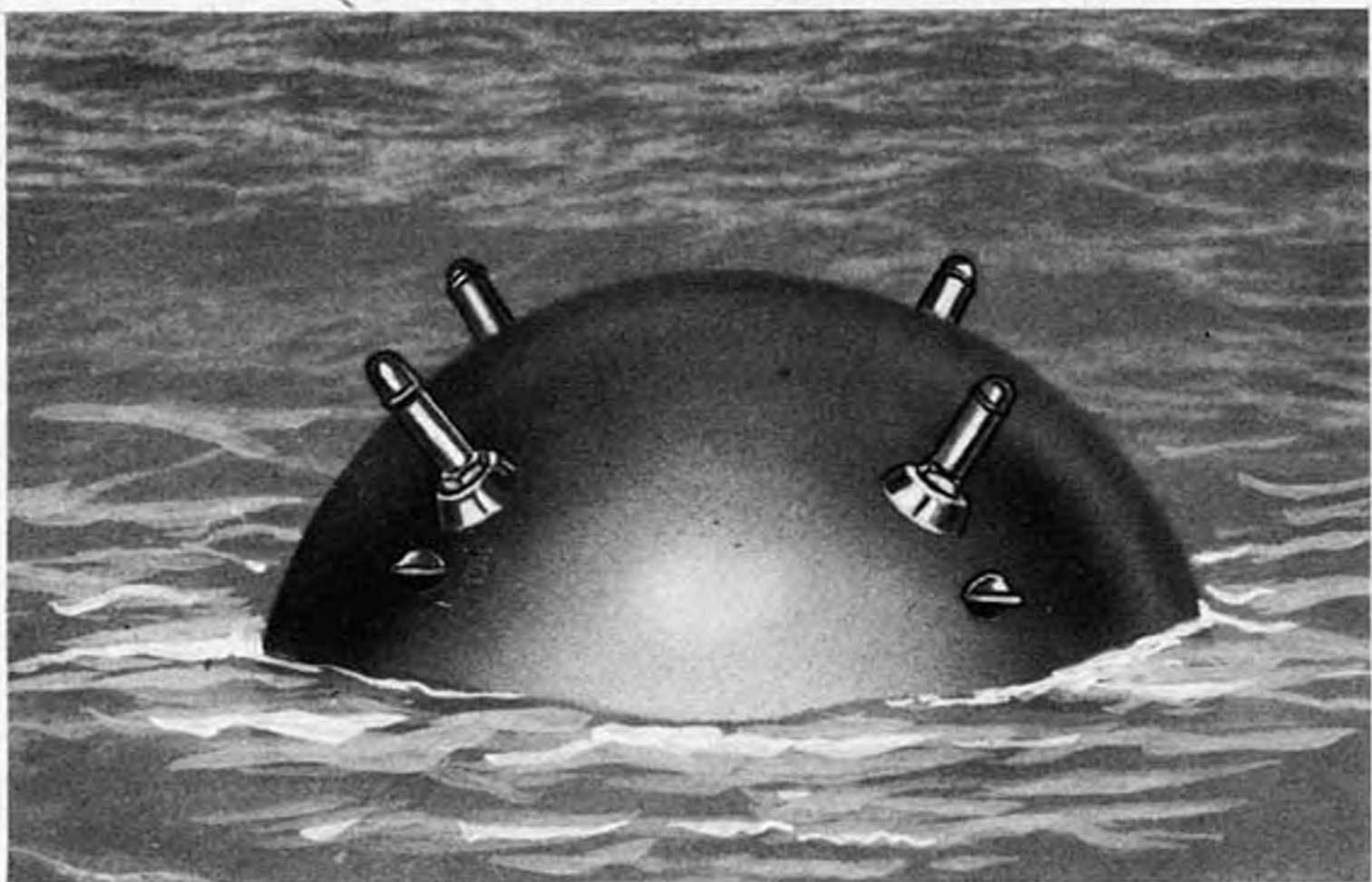

Fig. 15 - Mine Type IL, Floating

Mine Type ILGeneral

1. Moored, contact, chemical horn mine, laid by submarine.
2. Italian designation, "Torpedine aep 150/1935."
3. Defensive mine, for use in maximum depth of water of 1650 ft. against submarines or surface craft. Maximum depth of case when moored is 330 ft.

Description

## 1. Case

Shape	Two truncated spheres, joined by a cylindrical band.
Color	Black
Material	Steel
Diameter	36"
Length	54"
Charge	260 lb. cast TNT.
Total weight in air	Unknown

## 2. External fittings

Horns	Seven; four equally spaced around upper hemisphere; three equally spaced around lower hemisphere.
Cover plate	In center of upper hemisphere, secured by keep ring.
Base plate	In center of lower hemisphere, fitted with mooring lever and soluble plug gear.
Mooring hydrostat	On lower hemisphere, adjacent to base plate.
Positioning lugs	Twelve; three sets of four each, two sets on upper sphere, one set on lower sphere.

Operation

1. Mine takes depth by a variation of the loose bight hydrostat system whereby a small charge detonates when the mine rises to its pre-set depth, permitting a pawl to engage the mooring cable drum. Dissolution of a soluble plug allows mooring tension to pull out the mooring lever, closing the mooring safety switch, tripping the booster release lever and the mine is armed.
2. Standard chemical horn firing.
3. The only self-disarming device is the mooring safety switch which is designed to disarm the mine by opening the firing circuit upon release of mooring tension.

Precautions

1. Except in extreme emergency, do not attempt RMS unless the mooring lever has retracted fully.

RMS

1. Remove the keep ring and cover plate.
2. Reach in the case and remove the strongback from over the booster tube. The detonator and booster assembly is spring-loaded and should come out upon release of the strongback.
3. Dispose of detonator, booster and charge.

ITALIAN CONTACT MINES

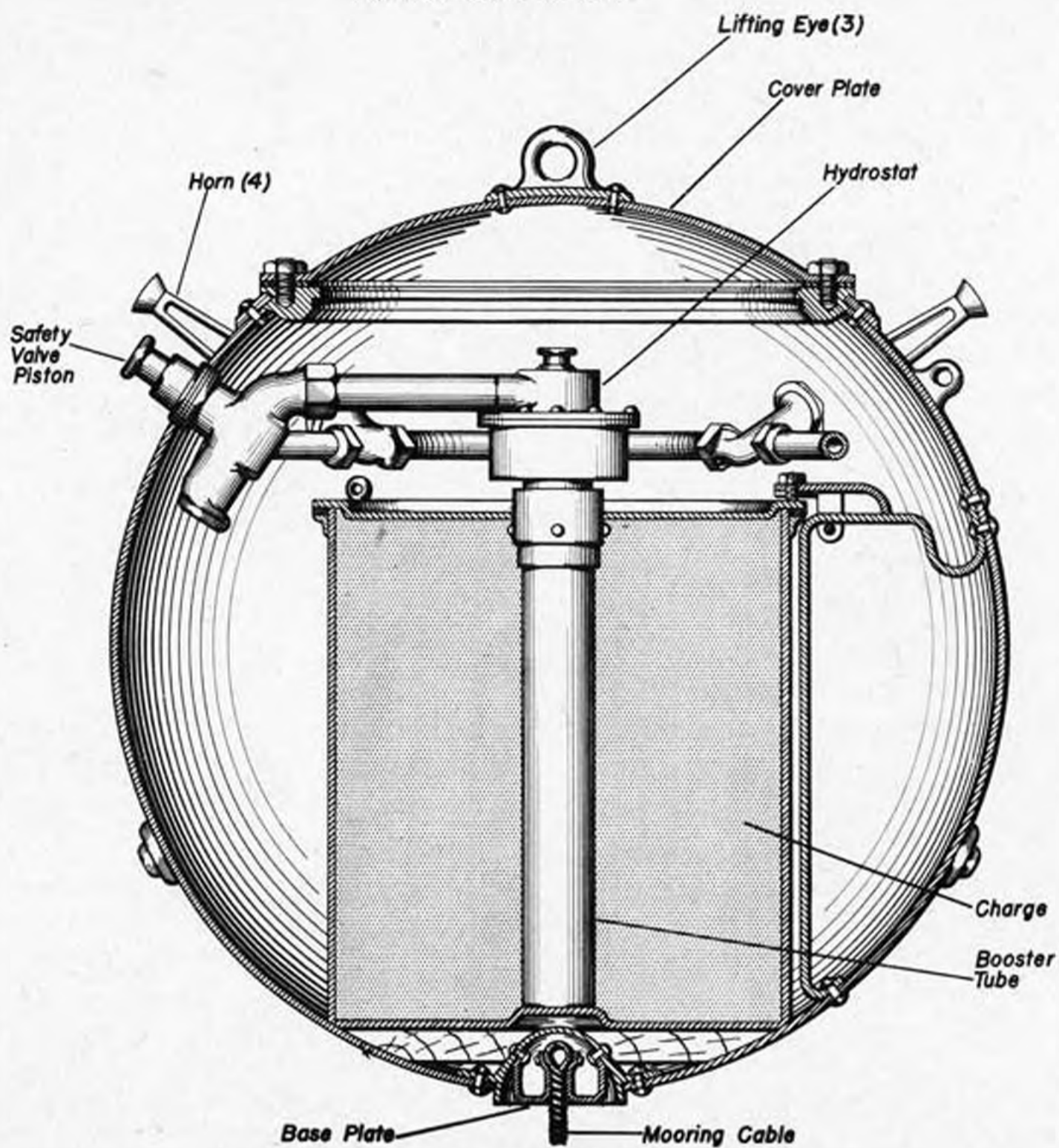

Fig. 16 - Mine Type IM, Sectional View

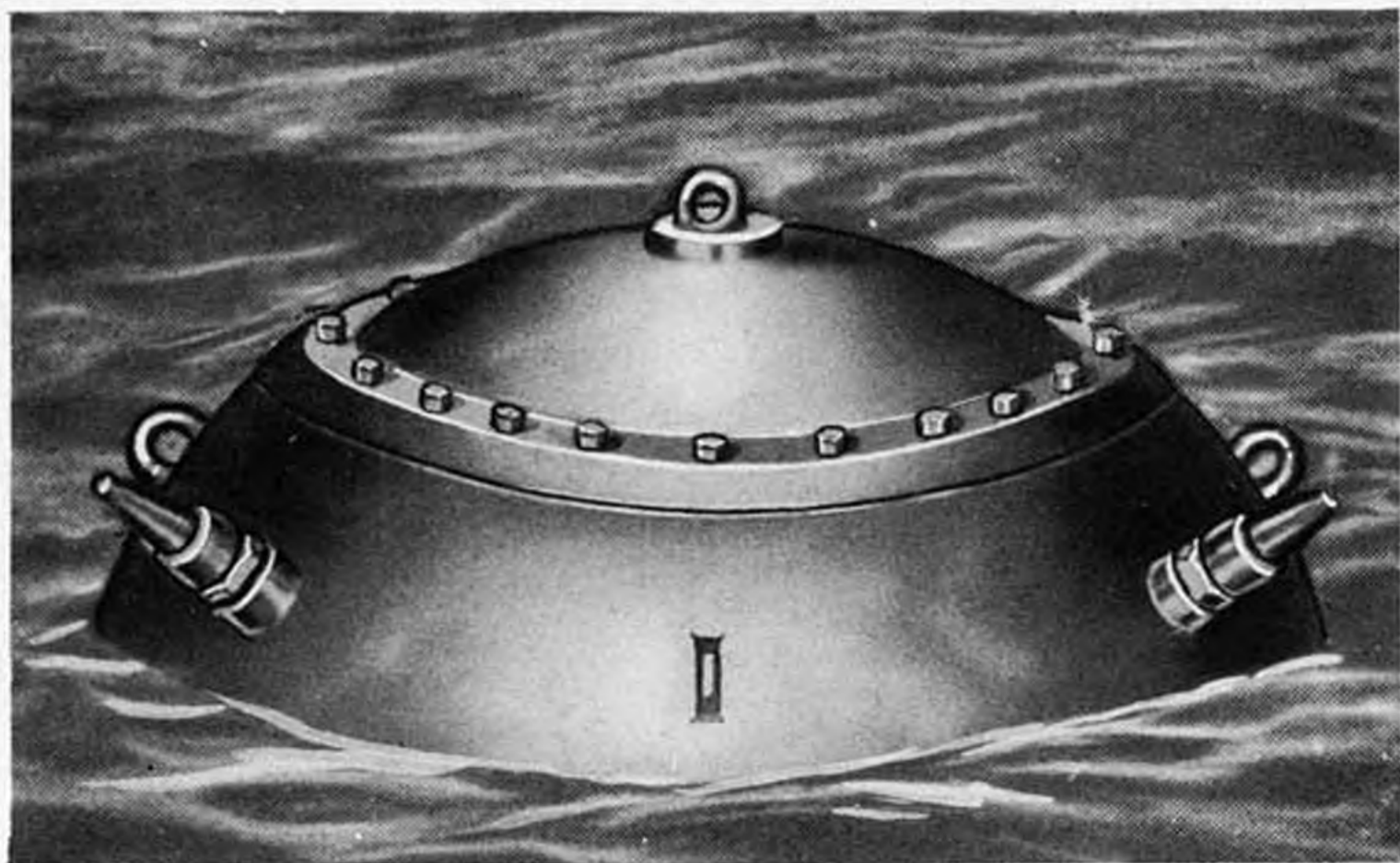

Fig. 17 - Mine Type IM, Floating

# ITALIAN CONTACT MINES

## Mine Type IX

### General

1. Moored, contact, hydrostatic horn mine, laid by surface craft.
2. Italian designation, "Torpedine am 70/1916 Harle."
3. Defensive mine, for use in maximum depth of water of 330 ft.

### Description

#### 1. Case

Shape	Spherical
Color	Black
Material	Steel
Diameter	30"
Charge	170 lb.
Total weight in air	Unknown

#### 2. External fittings

Horns	Four, equally spaced around upper hemisphere.
Cover plate	16" diam., in center of upper hemisphere.
Safety valve piston	On upper hemisphere, between two horns.
Lifting eyes	Three; one in center of upper hemisphere; two, 180° apart on upper hemisphere.
Base plate	In center of lower hemisphere, fitted with ball and socket joint for mooring eye.

### Operation

1. Mine takes depth by plummet. Dissolution of a soluble plug permits the safety valve piston to arm the hydrostatic firing device.
2. Mine fires when one of the horns is broken. This admits water to a hydrostat in the top center of the charge container. When the hydrostat is depressed, it frees a spring-loaded firing pin to impinge on the detonator.

### Precautions

1. See Introduction.

### R&S

1. Remove the cover plate.
2. Cut the hose leading to the hydrostat.
3. Unscrew and remove the hydrostat. The detonator and booster are attached thereto.
4. Dispose of detonator, booster and charge.

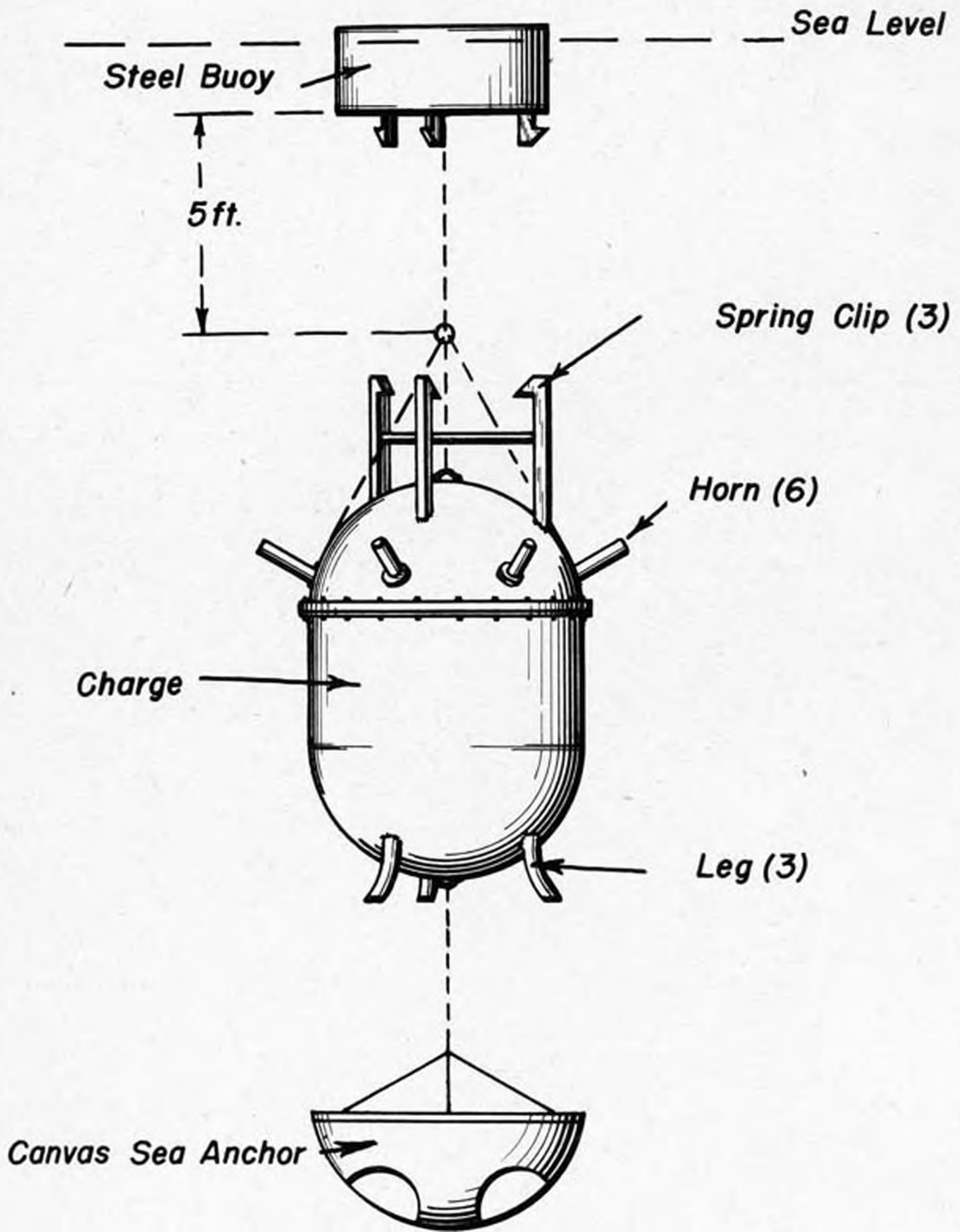

Fig. 18 - Mine Type IN, Armed Position

Mine Type INGeneral

1. Drifting, contact, mechanical horn mine, laid by aircraft.
2. Italian designation, "Aircraft Mine 70/1918."
3. Offensive mine, for use against surface craft. Depth of case when drifting is approximately five feet.

Description

1. The mine is reported as being cylindrical with hemispherical ends and carrying a charge of 154 lb. TNT.
2. External fittings
 

Horns	Six, equally spaced around upper end.
Hydrostat	In center of upper end.
Float	Secured to upper end by five ft. pendant.
Spring clips	Three, equally spaced around upper end.
Legs	Three, equally spaced around lower end.
3. A bucket-shaped sea anchor of unusual design is used with the mine.

Operation

1. When the mine is launched, the float separates from the case and the sea anchor fills with water and descends to the end of a suspension pendant. The mine then floats beneath the surface at a depth regulated by the length of the float pendant and the negative buoyancy of the sea anchor. Dissolution of a soluble plug allows the hydrostat to depress and arm the firing mechanism.
2. The mine fires when one of the horns is bent. The horn acts as a lever and, upon being bent, transfers the motion through a lever system to a wheel which rotates and releases a spring-loaded firing pin to impinge on the detonator.
3. The only self-disarming device is a galvanic cell which is designed to corrode a hole in the case and sink the mine after a period of nine hours.

Precautions

1. See Introduction.

RMS

1. None known.

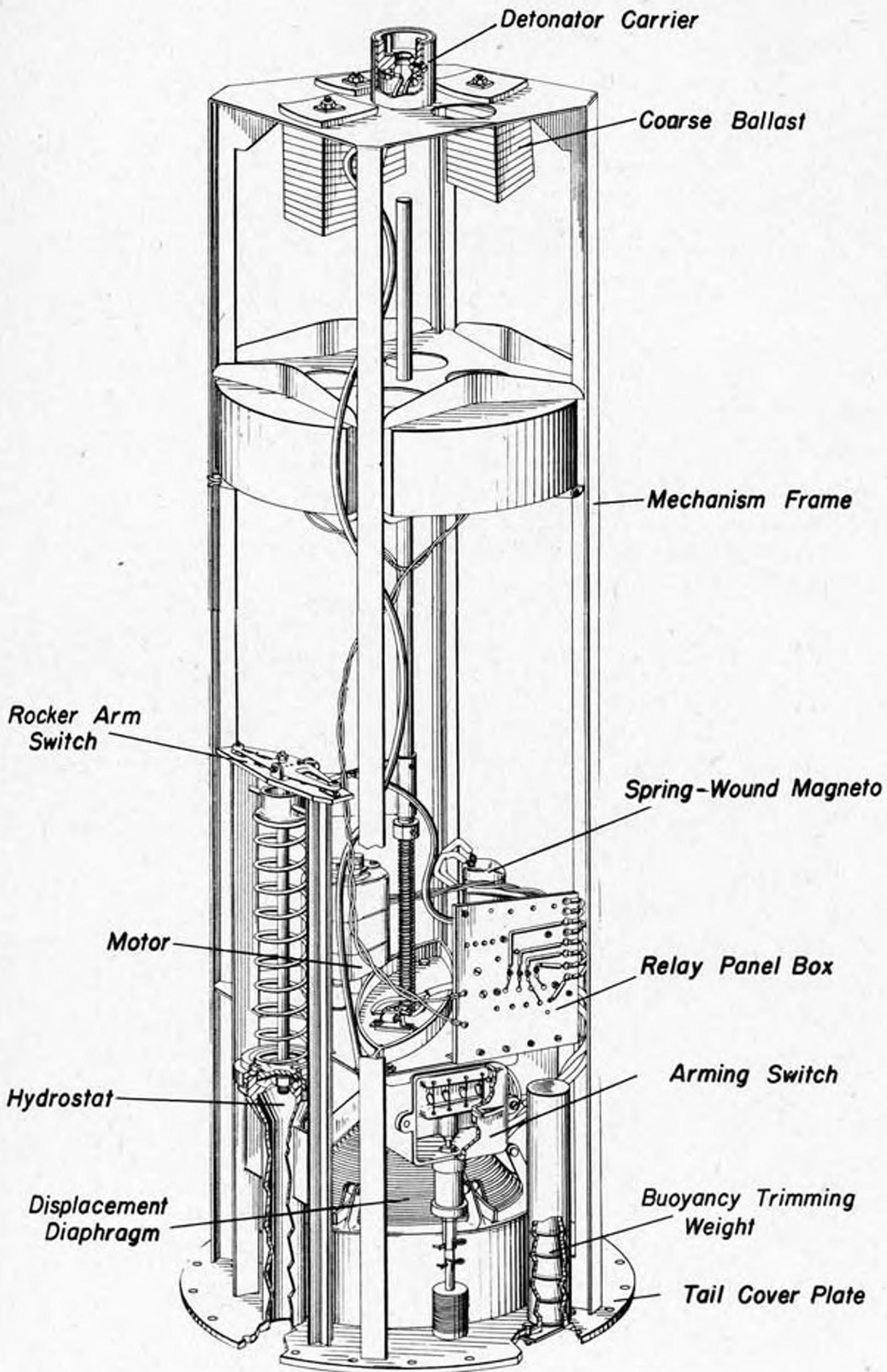

Fig.19 - Mine Type 10, Depth Control and Firing Mechanism, Perspective View

ITALIAN CONTACT MINES

Mine Type IO

General

1. Oscillating, percussion-fired mine, laid by surface craft or by aircraft with parachute.
2. Italian designation, "Torpedine Beta."
3. Offensive mine, for use in rivers, harbors and anchorages against shipping, docks, dams, bridges, etc.

Description

1. Case

Shape	Cylindrical, with truncated conical nose. Fitted with 5" cylindrical skirt on after end.
Color	Gray
Material	Steel
Diameter	18"
Length	8' 1 1/2"
Charge	425 lb. Torpex.
Total weight in air	780 lb.

2. External fittings

Tail cover plate	17 1/2" diam., on after end of case, secured by 29 bolts.
Hydrostat tube	1 1/2" diam., on tail cover plate, 12" from center.
Clock cover plate	2 3/4" diam., on tail cover plate, 2" from center, secured by four screws.
Arming switch knob	1/2" diam., on tail cover plate, 1 1/2" from center.
Buoyancy tube	1" diam., on tail cover plate, 2" from center.
Booster release mechanism	4" diam., screwed into center of nose.
Suspension lug	On top center line, 37" abaft the nose.
Filling hole cover	4" diam., 180° from top center line, secured by six screws.
Parachute release mechanism	On top center line at after end of case.

3. The depth control mechanism consists essentially of a 9" conical displacement diaphragm, a small motor and a hydrostatic motor control. The hydrostatic motor control may cause the motor to operate in either of two directions, direct control being accomplished by a rocker arm switch and associated relays. The motor in turn expands or contracts the diaphragm, depending on motor direction. Since one surface of the diaphragm is presented to the water on the tail cover plate, expansion or contraction of the diaphragm increases or decreases the displacement of the mine case, and thus, by definition, controls the buoyancy of the case.

Operation

1. When the mine is launched, a safety sleeve is removed from a boss on the tail cover plate. This permits the arming switch to close and battery current then energizes the relays of the hydrostatic motor control. Upon impact with the water, the mine sinks to a considerable depth due both to momentum and to the fact that the displacement diaphragm is fully retracted, thus giving the mine its greatest possible negative buoyancy. The hydrostatic motor control starts the motor which expands the diaphragm. As the diaphragm expands for the first time, it starts the scuttling clock and withdraws a safety fork from the inertia firing mechanism. The mine then rises rapidly to its pre-set depth, at which point the hydrostatic motor control reverses the motor direction and

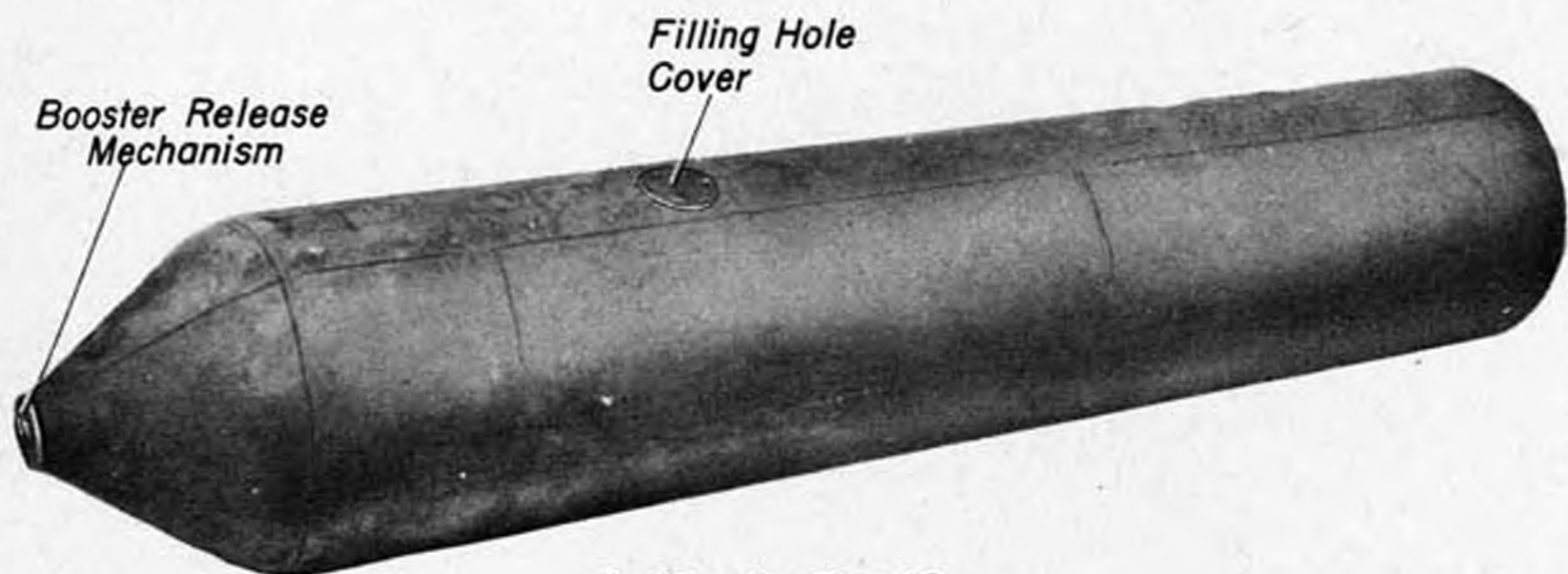

Fig. 20 - Mine Type 10

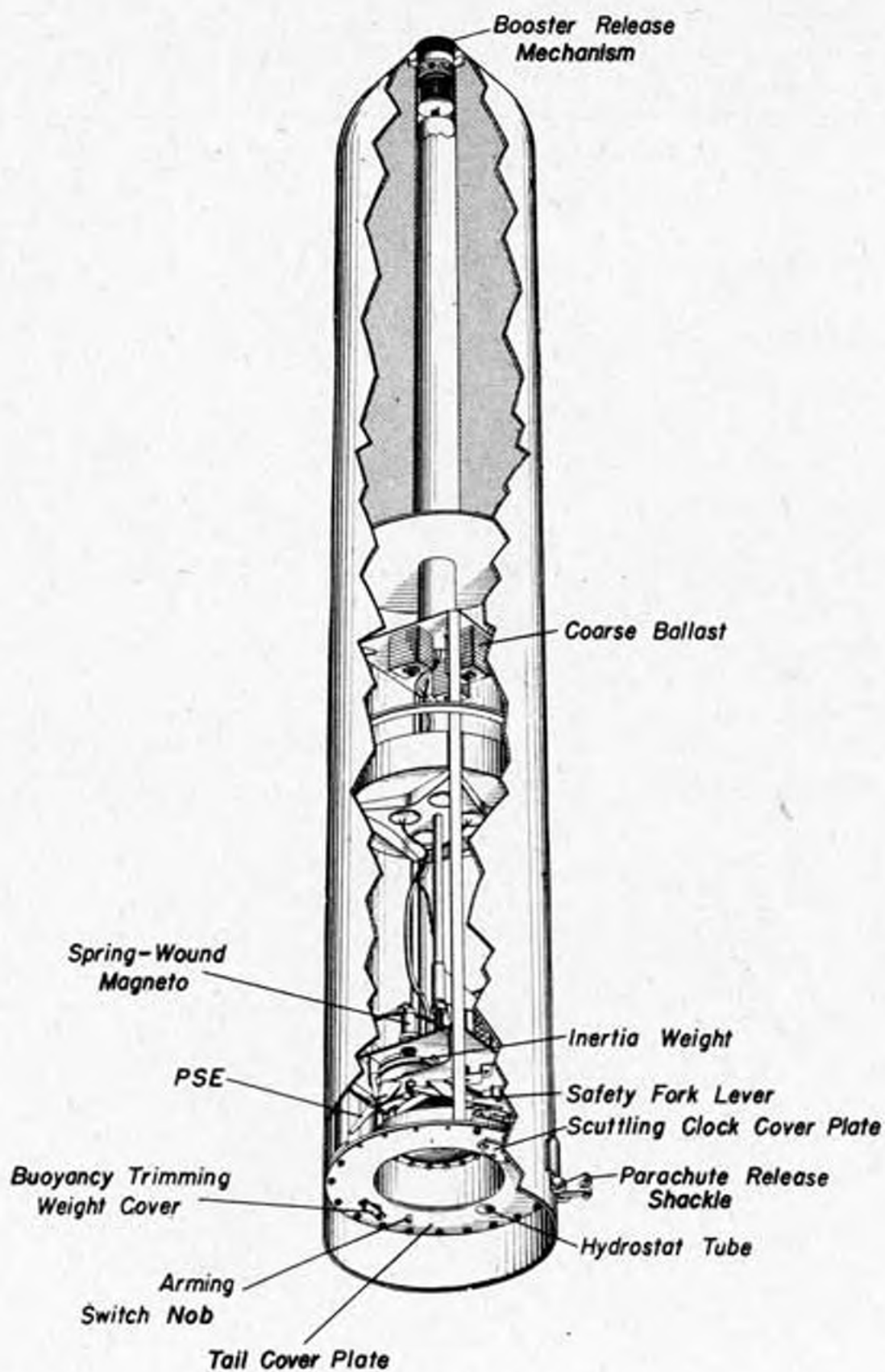

Fig. 21 - Mine Type 10, Perspective View

## ITALIAN CONTACT MINES

(Mine Type IO, Cont'd.)

the mine starts to sink. The mine then oscillates near its set depth. Dissolution of a soluble plug permits the booster release mechanism to house and lock the booster over the detonator and the mine is armed.

2. The mine fires upon receipt of a lateral blow sufficient to displace an inertia weight from its seat within the firing mechanism. Lateral displacement of the weight removes a stop from a small, spring-wound magneto which then turns, producing sufficient current to fire the detonator.
3. The only self-disarming device is the scuttling clock which, upon completion of its pre-set period (1-48 hours), is designed to retract the diaphragm permanently and thus sink the mine.

### Precautions

1. Do not remove the tail cover plate of the mine until after the booster has been removed. A P.S.E., consisting of a lever system attached to both the inertia weight and the tail cover plate, is designed to trip the firing magneto if an attempt is made to remove the tail cover plate.

### RMS

1. Remove the booster release mechanism and booster.
2. From a safe distance, remove the tail cover plate and attached fittings. Considerable force may be necessary to accomplish this and the detonator will probably fire during the process.
3. Dispose of booster and charge.

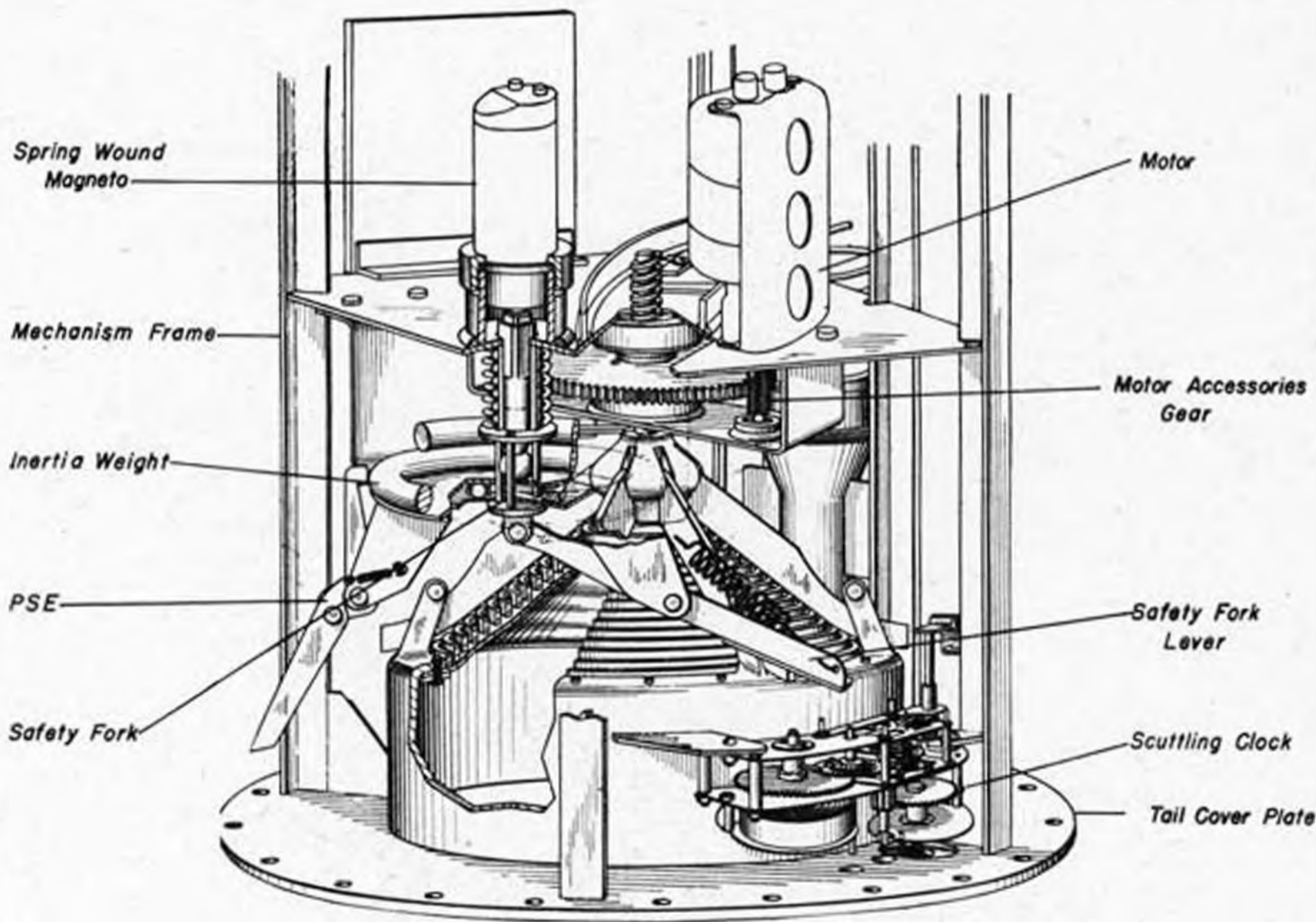

Fig. 22- Mine Type IO, Depth Control and Firing Mechanism, Perspective View

ITALIAN CONTACT MINES

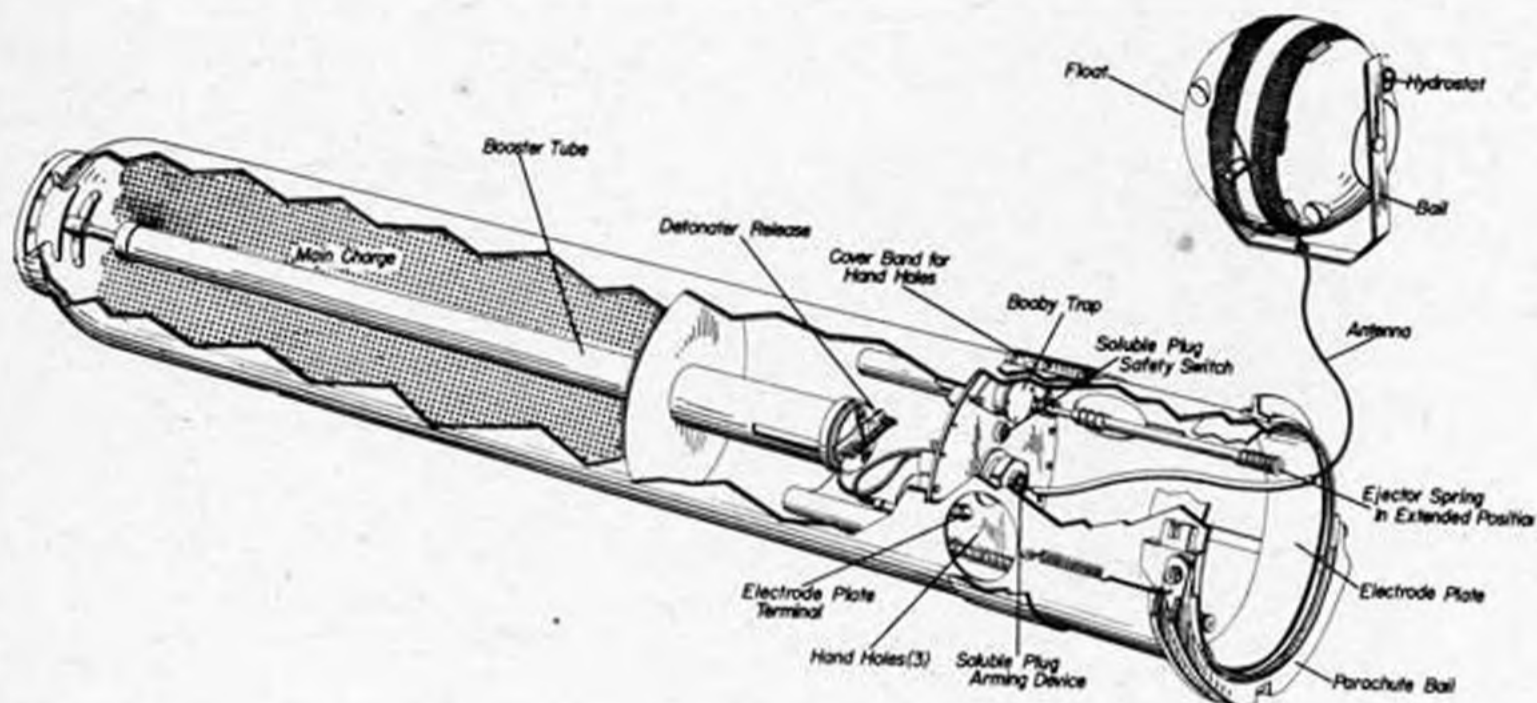

Fig. 23 - Mine Type IP, Perspective View

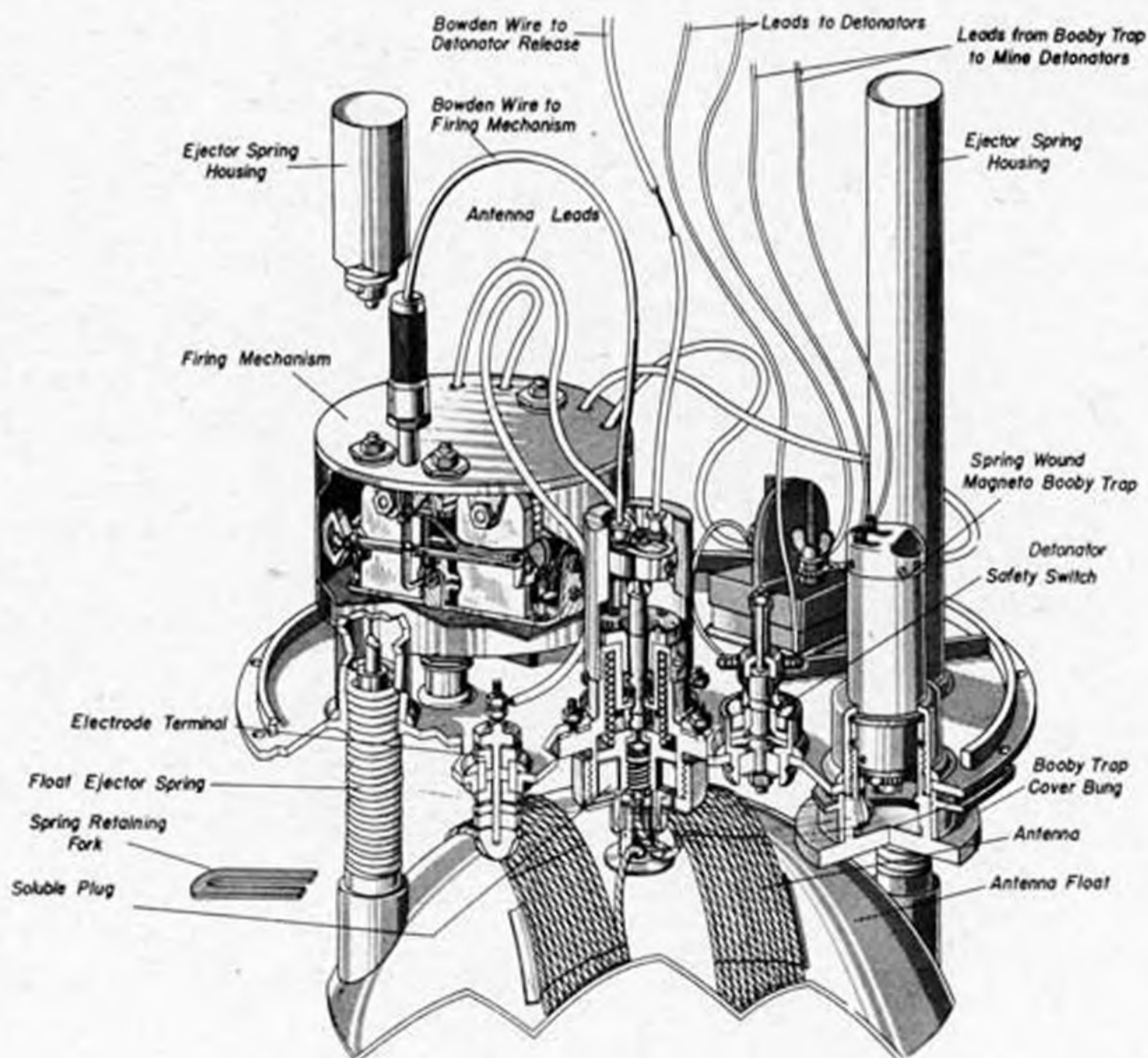

Fig. 24 - Mine Type IP, Base Plate, Perspective View

Mine Type IPGeneral

1. Ground, contact, antenna mine, laid by aircraft with parachute.
2. Italian designation, "Torpedine Tipo V."
3. Offensive mine, for use in maximum depth of water of 110 ft. against surface craft.

Description

## 1. Case

Shape	Cylindrical, with rounded nose. Fitted with 19" cylindrical skirt on after end.
Color	Brown or gray-green.
Material	Steel
Diameter	18"
Length	8'2"
Charge	739 lb. (type of explosive unknown; believed similar to Minol)
Total weight in air	1101 lb.

## 2. External fittings

Nose cover plate	13" diam., in center of nose, lap-fitted, secured by eight bolts. Fitted with lifting eye in center.
Tail cover plate	17 1/2" diam., fitted to flange inside skirt 19" forward of after end, secured by 18 bolts.
P.S.E. cover bung	4" diam., on tail cover plate, 6 7/8" from center, screwed on to boss.
Soluble plug housing	In center of tail cover plate.
Detonator safety switch	1 1/4" diam., on tail cover plate, 4" from center, secured by keep ring from inside.
Antenna connector	On tail cover plate, 6" from center.
Float ejector springs	Two, 180° apart on tail cover plate, 6" from center.
Float release bail	Spring-loaded, swivelled on two lugs, 180° apart on after end of case, fitted with parachute release mechanism.
Steel band	6 1/4" wide, fitted around case 10 1/2" forward of after end; covers three equally spaced 5 1/2" diam. access holes.
Antenna float	Copper sphere, 17 1/2" diam., fitted with hydrostatic switch and mooring bail and forms drum for 80 ft. copper antenna. Fitted inside case between tail cover plate and float release bail prior to release.
Antenna electrode	Copper band, 16 1/2" diam., 4" wide, secured to and insulated from inside of skirt at after end.

Operation

1. When the mine is launched, release of parachute tension upon impact with water operates the parachute release mechanism. Dissolution of a solu-

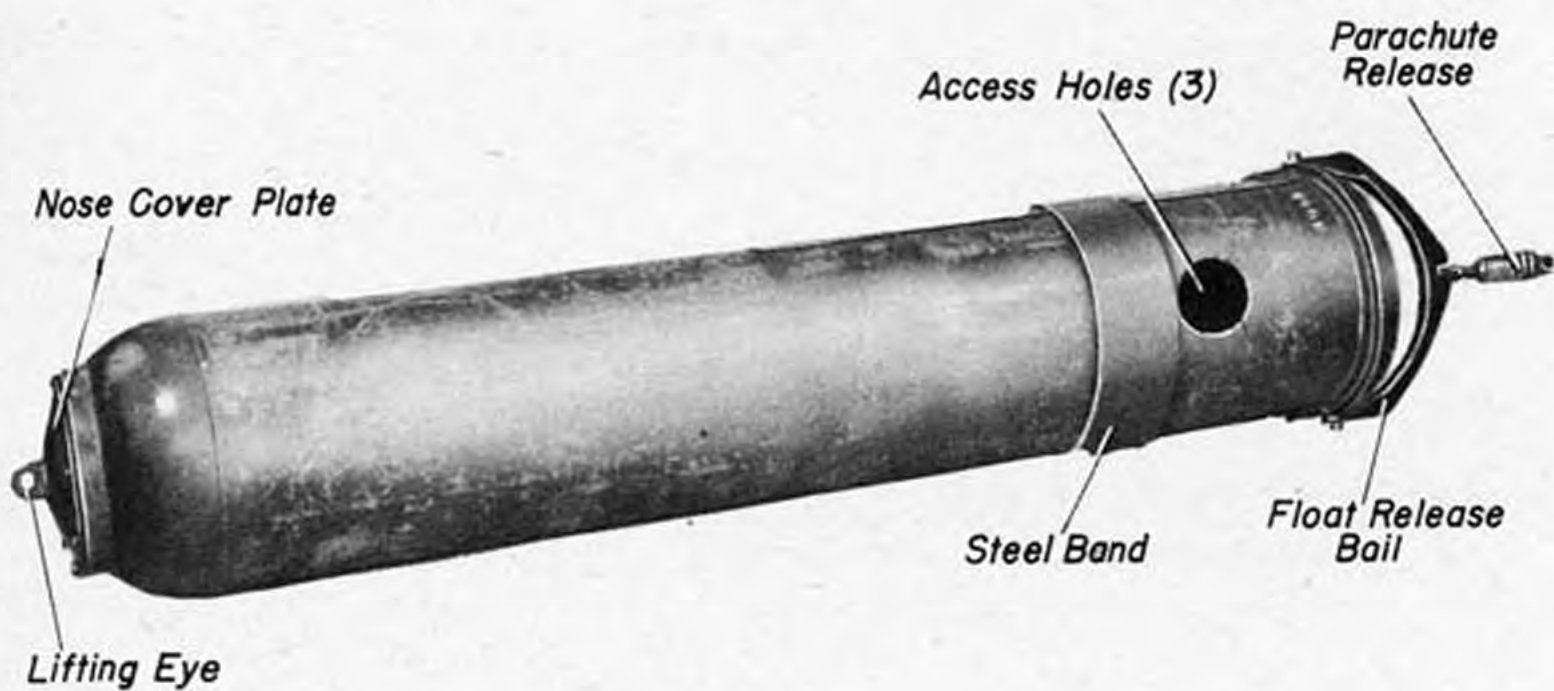

Fig. 25 - Mine Type IP

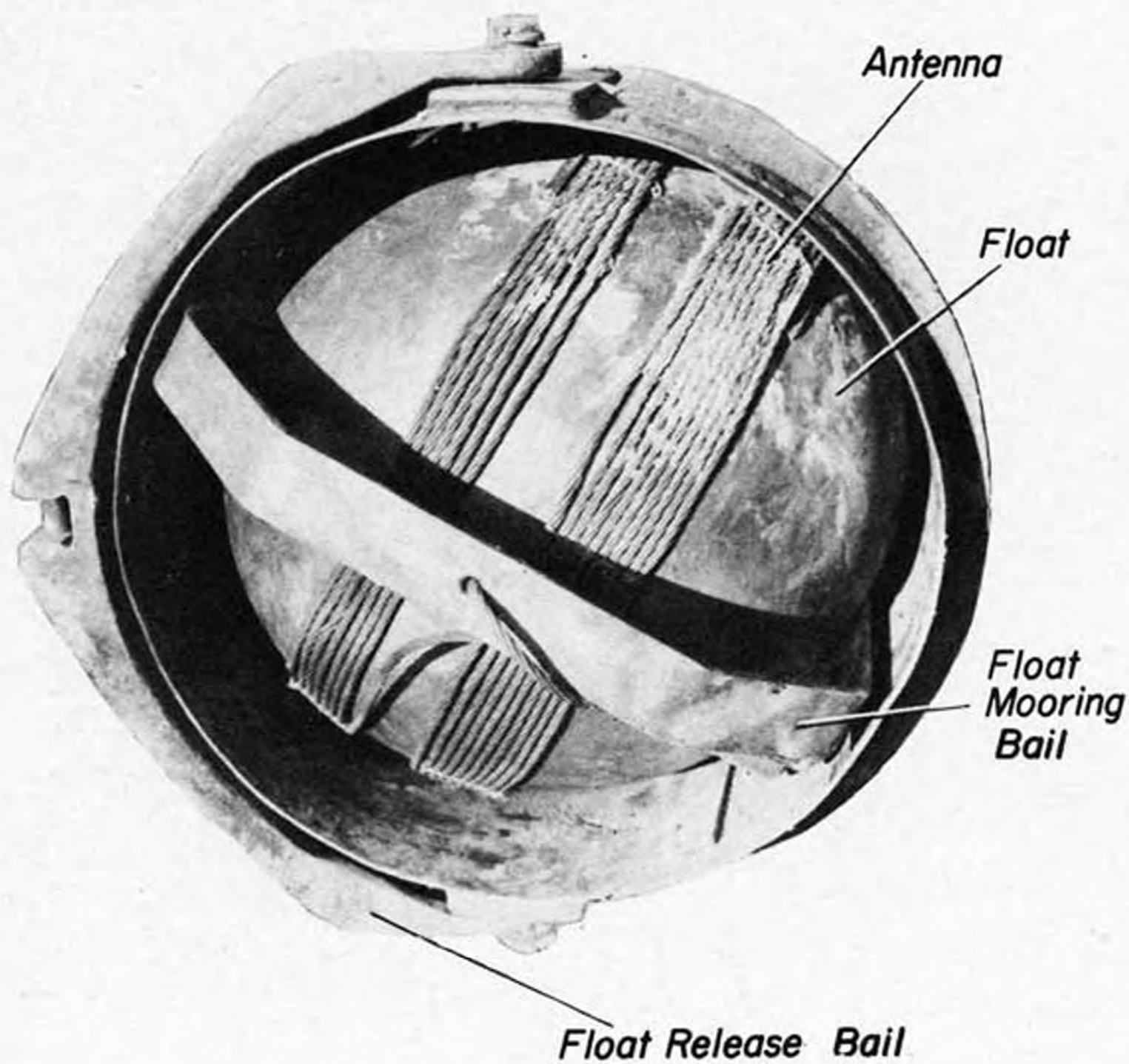

Fig. 26 - Mine Type IP, After End

## ITALIAN CONTACT MINES

(Mine Type IP, Cont'd.)

ble plug releases a spring-loaded spindle inside the tail cover plate. Release of the spindle performs the following arming functions:

- (a) It frees the float release bail which swings clear, allowing the float ejector springs to force the float out of the case. The float then rises, unreeling the antenna. At the pre-set depth, its hydrostat allows a locking stud to engage the mooring bail, preventing further rotation of the float and mooring it in place.
- (b) It operates a bowden wire which releases the detonator carrier and allows a coil spring to house the detonator in the booster.
- (c) It operates a bowden wire which frees a small relay, thereby arming the spring-wound firing magneto.
- (d) It completes a safety switch fitted in the circuit between the antenna and the magneto relay.

Dissolution of another soluble plug allows another spring-loaded switch to make, thereby completing the firing circuit and arming the mine.

2. The mine fires when the antenna or float contacts a metal of a type sufficiently dissimilar to set up a 10-15 milliampere current in the antenna circuit. This current operates a sensitive relay which in turn operates a lever system, releasing the magneto which fires the detonator.
3. No self-disarming devices are fitted.

### Precautions

1. Never remove the P.S.E. cover plate until after the antenna has been disconnected and the detonator leads cut. Removal of this cover plate is designed to release the magneto and fire the mine as noted above.
2. Never attempt RMS underwater. If the mine is found on the bottom or in the surf, haul it ashore from a safe distance before beginning operations.

### RMS

1. Slide back the steel band which covers the access holes and disconnect the antenna from its connector on the tail cover plate.
2. Retract the detonator safety switch and wedge it out.
3. Remove the tail cover plate.
4. Cut and tape each lead separately; disconnect bowden wires as necessary.
5. Remove the detonator and booster.
6. Dispose of detonator, booster and charge.

# MINE DISPOSAL HANDBOOK

## PART V

### ITALIAN UNDERWATER ORDNANCE

. . . . .

#### CHAPTER 2

#### ITALIAN TORPEDOES

Torpedoes

ITALIAN TORPEDOES

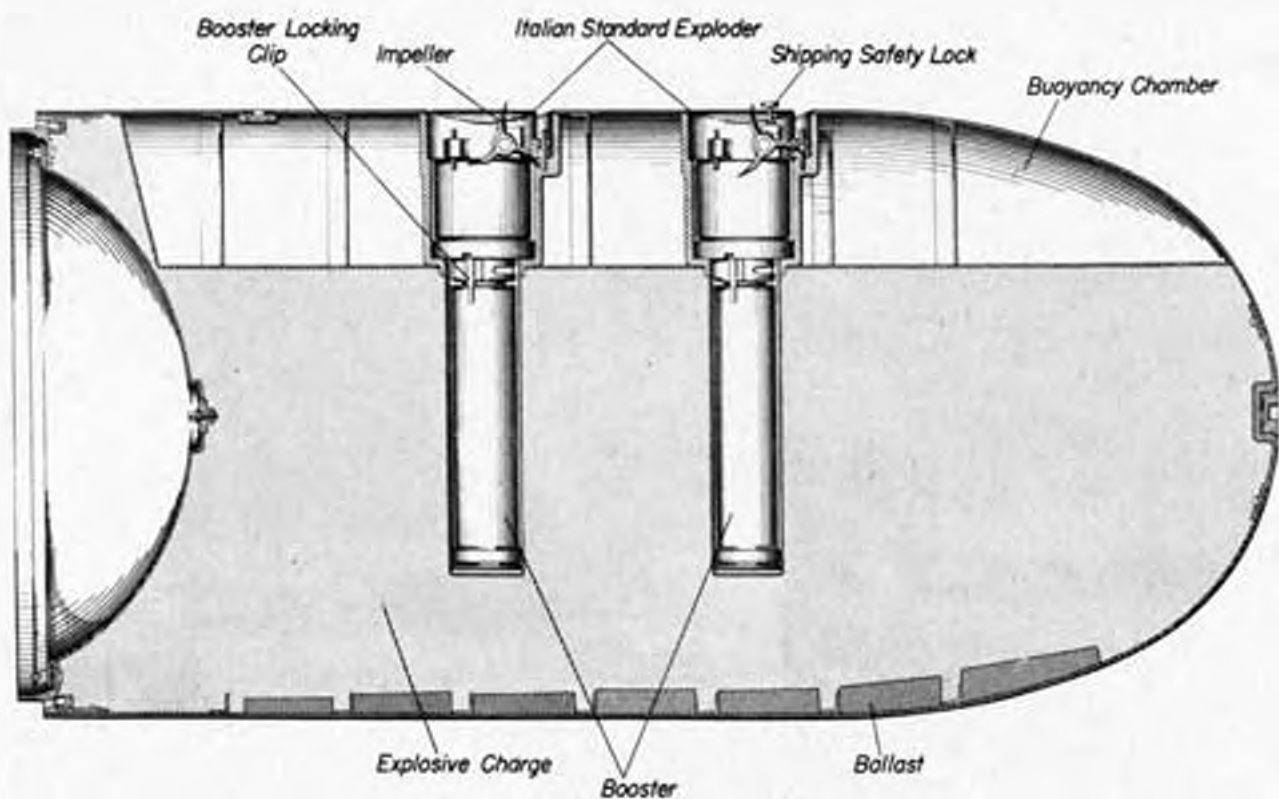

Fig. 1 - Warhead Type A, Sectional View

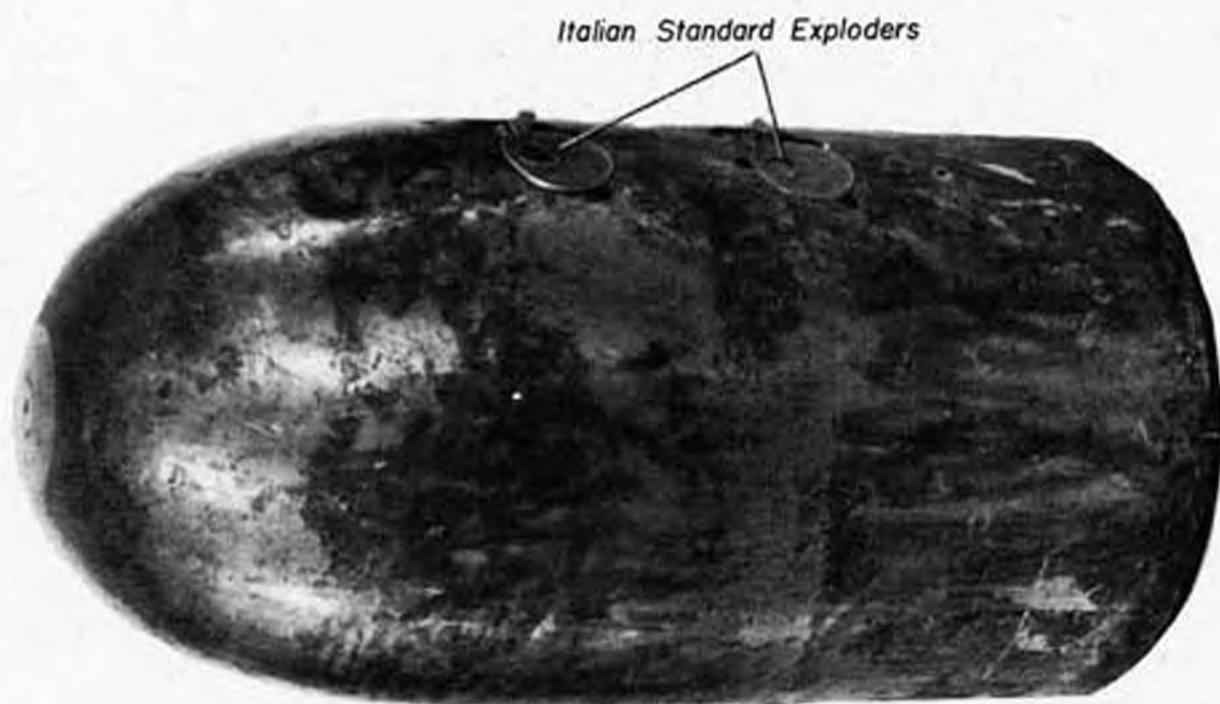

Fig. 2 - Warhead Type A

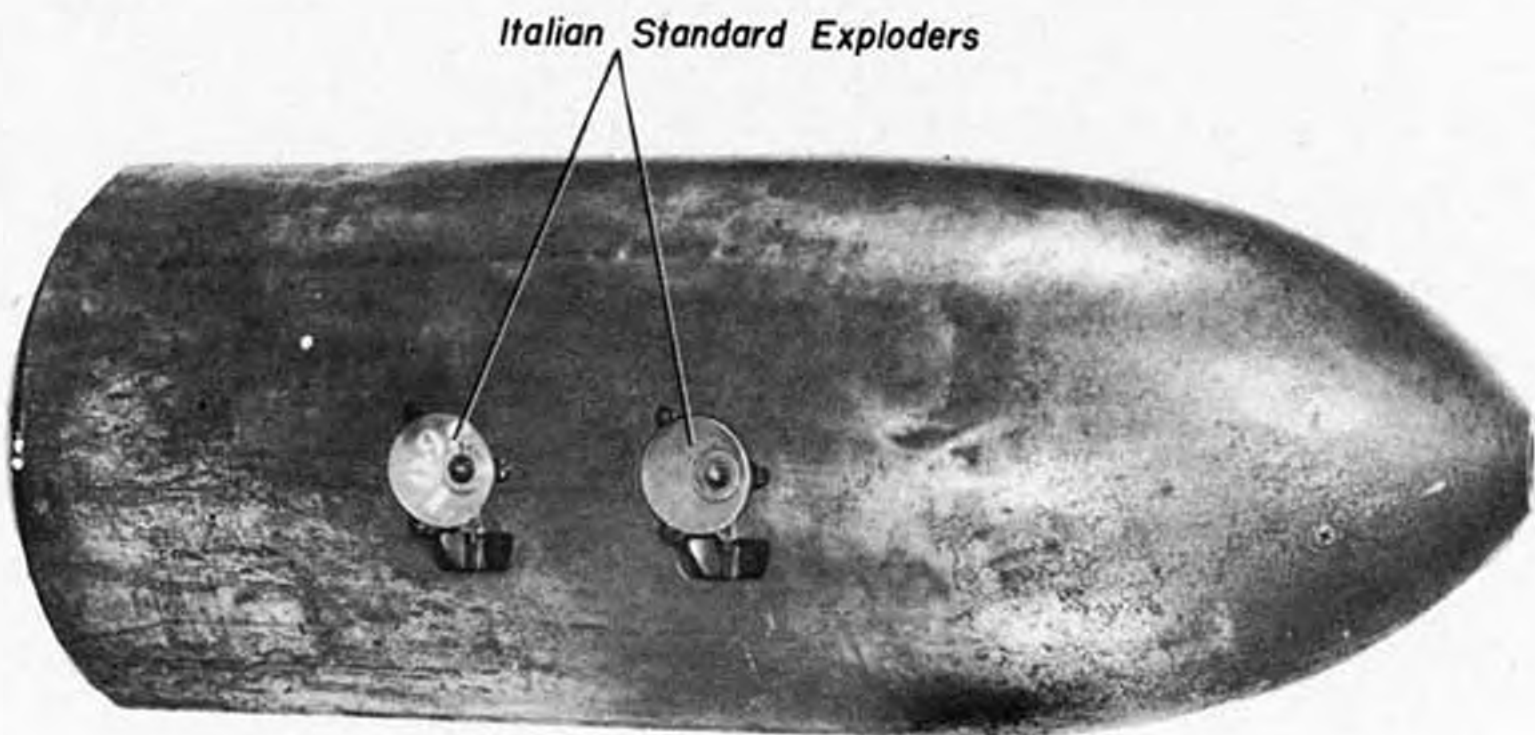

Fig. 3 - Warhead Type B

Introduction

1. The torpedoes of the Italian Navy are 21" and 18" in diameter and are all air-driven with the single exception of the 19 1/2", electrically-driven, aircraft-launched, circling torpedo. The Italians are known to have used some submarine-launched electric torpedoes also, but it is believed that these were obtained from the Germans. This chapter does not contain detailed information with respect to the entire torpedo assemblies, the single exception being the circling torpedo which is sufficiently unique to warrant full treatment. Data are included on representative examples of recovered warheads and the known types of exploders are covered in detail.

Italian WarheadsGeneral

1. Although many types of Italian warheads have been examined, all types, excepting the SIC and circling torpedo warheads, are simply constructed and are quite similar in design. The warheads are either 18" or 21" in diameter, are constructed of steel, and contain no special features or fittings except the transverse exploder pocket on the top center line. Later models may contain two exploder pockets on the top center line, about 10" apart, either of which will receive the Standard Italian Exploder.

Description

1. Data on three standard 21" warhead types follow below:

## (a) Type A (Round Nose)

Length	40"
Distances from centers of exploder pockets to after flange.	14" and 23"
Diameter of nose plug	1 3/4"
Marking on nose	GSE MARISUB LA SPEZIA

## (b) Type B (Pointed Nose)

Length	52"
Distances from centers of exploder pockets to after flange	16" and 25"
Diameter of nose plug	3"
Marking on nose	GSE MARISUB TARANTO

## (c) Type C (Round Nose)

Length	45"
Distances from centers of exploder pockets to after flange	16" and 26"
Diameter of nose plug	1 1/2"
Marking on nose	S.I. 270/553.4 x 7.2 C.P. GSE TARANTO

2. SIC Warhead

- (a) This warhead is very similar externally to the standard types treated above. It is 46" long, 21" in diameter, and contains the two pockets on its top center line, the respective centers of which are 17" and 27" from the after warhead flange. The most obvious difference apparent to a casual inspection is the fact that the after pocket is fitted to receive the five securing screws for the SIC activator rather than the three screws which secure the Standard Exploder.
- (b) The internal arrangement of the components of the magnetic firing device is as follows (all parts fitted just forward of the after bulkhead):

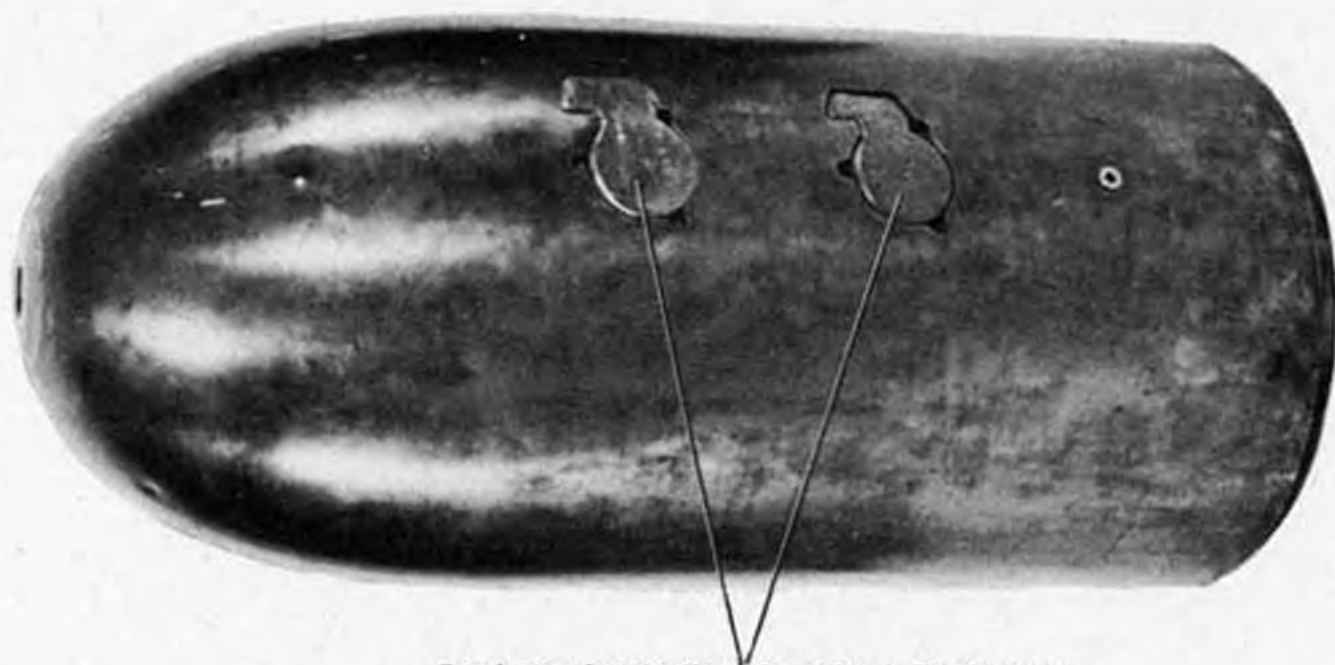

*Pockets for Italian Standard Exploders*

Fig. 4 - Warhead Type C

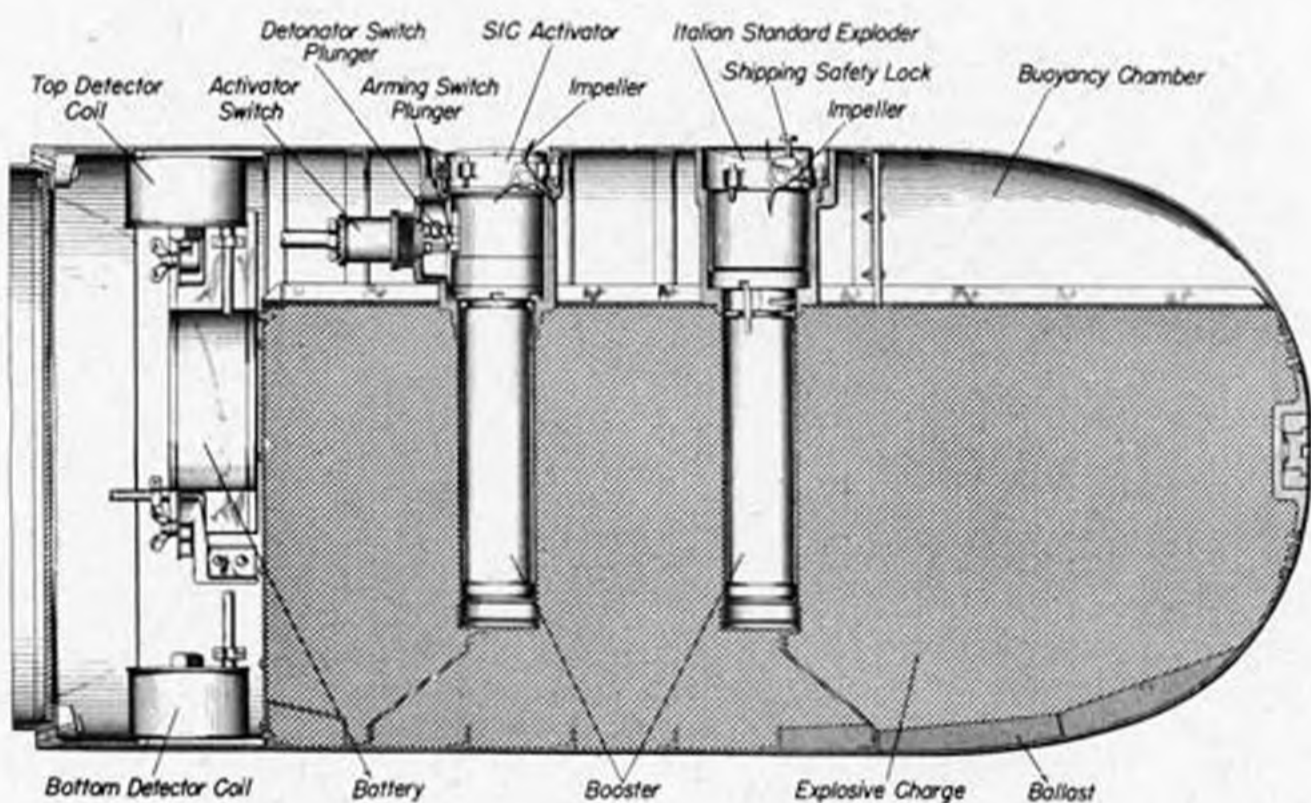

Fig. 5 - SIC Warhead, Sectional View

(Italian Warheads, Cont'd.)

- (1) Two detector coils, one on the top center line and one on the bottom center line.
  - (2) An amplifier unit on the starboard side.
  - (3) A battery on the port side.
  - (4) A magnetic test switch on the lower starboard side.
- (c) Light-colored, rubberized cables extend within the warhead as follows:
- (1) From the battery to the amplifier.
  - (2) From the amplifier to the magnetic test switch.
  - (3) From the upper detector coil to the magnetic test switch.
  - (4) From the lower detector coil to the magnetic test switch.
  - (5) From the amplifier to a switch on the after edge of the activator pocket.

3. The circling torpedo warhead is treated elsewhere in this chapter.

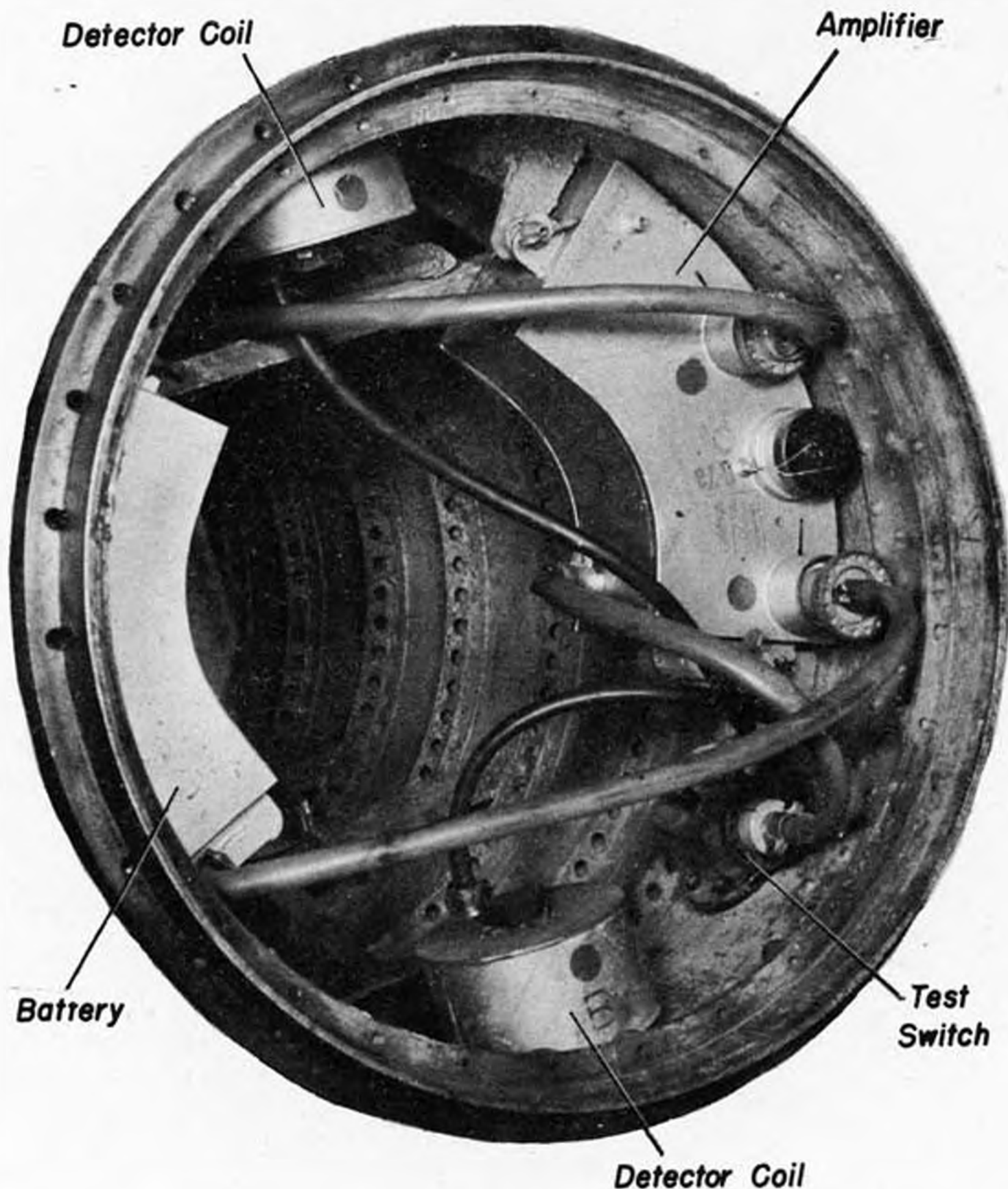

Fig 6- SIC Warhead

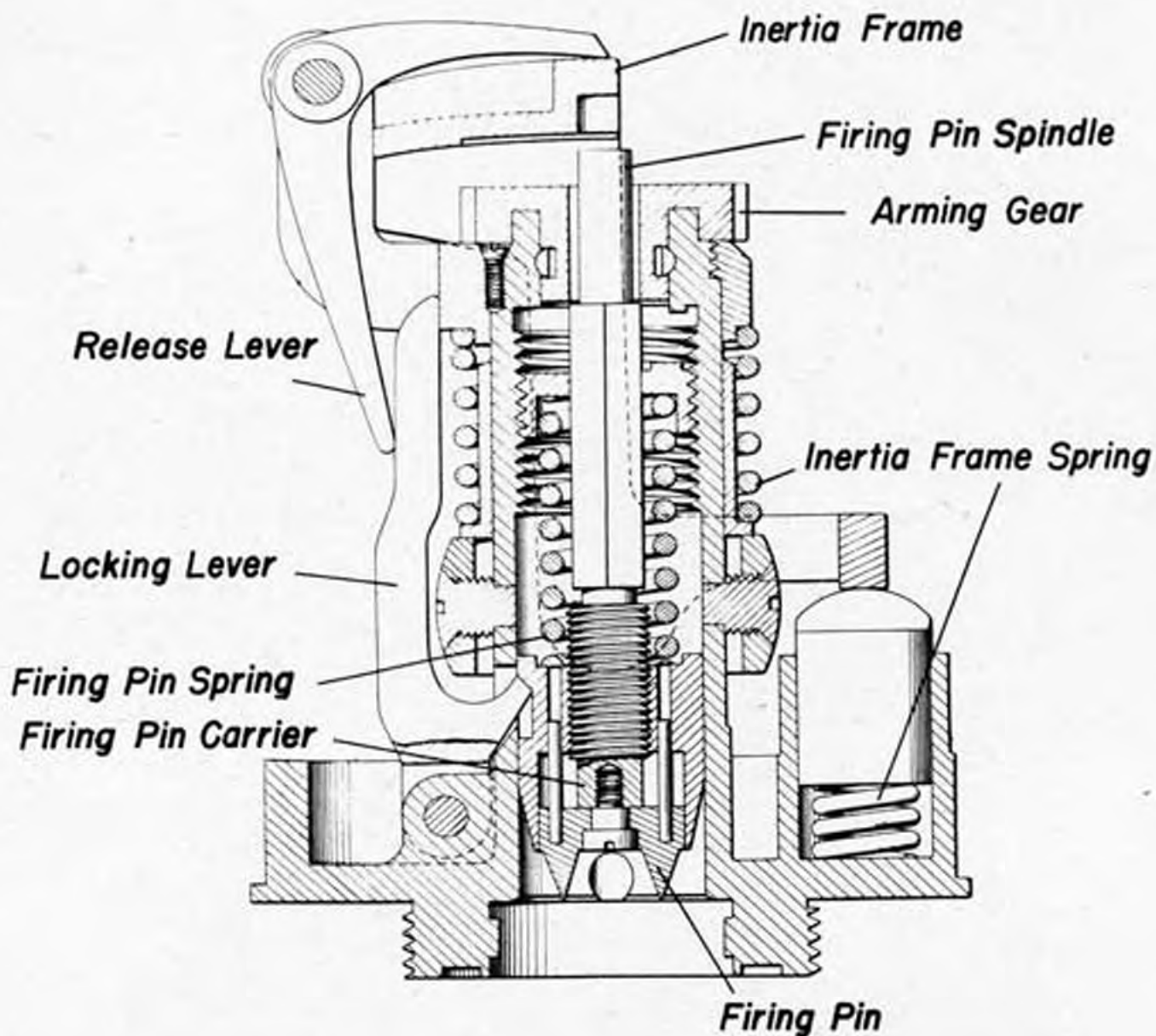

Fig. 7 - Italian Standard Exploder, Armed Position, Sectional View

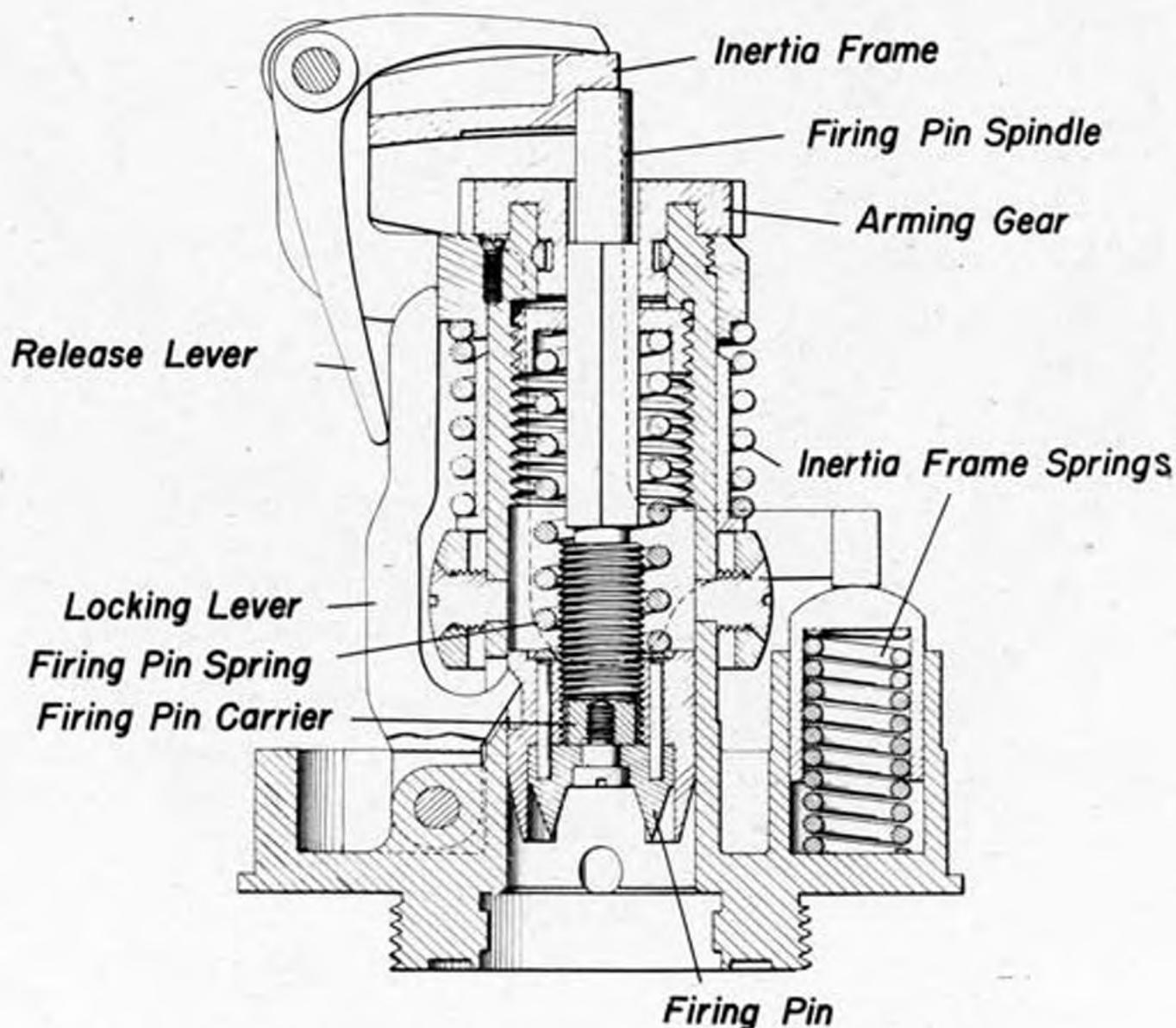

Fig. 8 - Italian Standard Exploder, Unarmed Position, Sectional View

Italian Standard ExploderGeneral

1. Impact-inertia type, fitted in transverse pocket on top center line of warhead. Used in surface craft, aircraft and submarine-launched torpedoes; two exploders usually fitted to each warhead.

Description1. External

- (a) The exploder is 15 3/4" long, 3 3/4" in maximum diameter, and is composed of the following main parts:

- (1) An upper section, consisting of a cylindrical brass housing, 5" long, which encloses the main working parts of the exploder. A three-bladed impeller, mounted on the end of an impeller shaft which protrudes from the side of the housing, rotates in an impeller trough adjacent to the exploder pocket. An inspection port covered by a transparent plastic window is fitted in the top cover.
- (2) A lower section, consisting of a cylindrical brass housing, 10 3/4" long and 2 1/4" in diameter, which encloses the booster and detonators. The detonator carrier is secured to the base of the upper section by a keep ring (left hand threads). The booster screws to the lower end of the detonator carrier and is locked by an L-shaped clip.

- (b) Markings on the exploder body are as follows:

- (1) The words Graduazion Immobilizzazione in Geridi Elichetta stamped around the inspection port.
- (2) The exploder serial number stamped on the top face.

2. Internal

- (a) The primary working parts of the exploder are as follows:

- (1) A worm gear, driven by the impeller, which drives:
  - (i) The arming indicator assembly, consisting of a gear train, a calibrated wheel, an indicator flap and a spring-loaded shaft. The shaft is fitted at its upper end with a small arm which is painted red and on which the word Smobilizz is stamped.
  - (ii) The arming gear which is mounted on the vertical axis and which contains a square hole in its center.
- (2) A square-shafted, spring-loaded firing pin spindle. The spindle is rounded at the top and screws into a firing pin head containing two firing pins. The spindle and head are contained in a cylindrical housing which is threaded at the top. The square shaft of the spindle engages the square hole in the arming gear prior to arming.
- (3) An inertia frame, pivoted to the firing pin housing, and two springs which tend to hold the frame in the unfired position. The underside of the top of the frame contains a small recess into which the rounded top end of the firing pin spindle fits, thereby locking the frame prior to arming.
- (4) A firing spring compressing disc, threaded externally and fitted with a square hole in its center, screws into the top of the firing pin housing and fits over the firing pin spindle.
- (5) The firing pin release lever and the firing pin locking lever. The upper end of the firing pin release lever bears down upon the projection on top of the inertia frame and its lower end restrains the upper end of the firing pin locking lever. The lower end of the firing pin locking lever protrudes through the side of the firing pin housing and restrains the firing pin head.

3. Method of Mounting

- (a) The exploder is slipped into the warhead and secured by three square-headed bolts.



Fig. 9 - Italian Standard Exploder

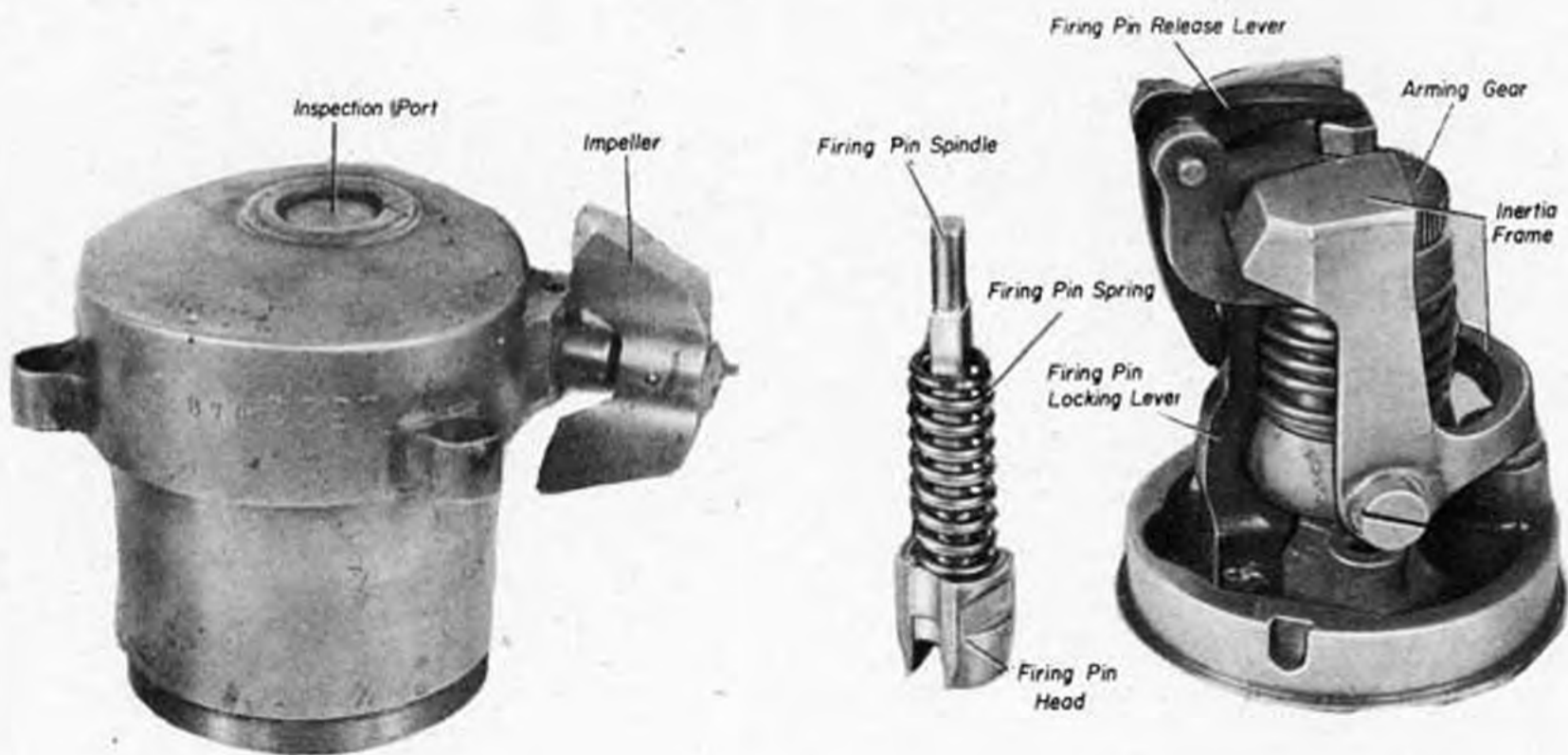

Fig. 10 - Italian Standard Exploder, Booster Removed

Fig. 11 - Italian Standard Exploder, Housing Removed

## ITALIAN TORPEDOES

(Italian Standard Exploder, Cont'd.)

### Operation

1. The arming range is set manually prior to launching by running off the desired number of turns on the impeller. The maximum arming range is represented by 500 impeller turns. When the torpedo is launched, impeller rotation drives the worm gear, thereby performing the following arming functions:
  - (a) The calibrated wheel of the arming indicator assembly rotates and, when the required number of impeller turns has been run off, the spring-loaded shaft is released and the red-painted arm is interposed between the calibrated wheel and the window. This ordinarily occurs when the exploder lacks 65 impeller turns of being fully armed and indicates that the exploder is in a dangerous condition, but not necessarily fully armed.
  - (b) The arming gear rotates, thereby rotating the firing pin spindle and the firing spring compressing disc. As the firing pin spindle rotates, it moves downward causing the firing pins to emerge from the housing. As the firing spring compressing disc rotates, it also moves downward, compressing the firing spring. When the complete arming distance is run off, the firing pin spindle moves downward sufficiently to permit its rounded top to disengage and unlock the inertia frame and its square shaft moves out of the hole in the center of the arming gear which idles for the remainder of the run.
2. The exploder fires upon receipt of a blow sufficient to displace the inertia frame. Displacement frees the firing pin release lever from the projection on the inertia frame, thereby releasing the firing pin locking lever. The tension of the firing spring then forces the locking lever outward and carries the firing pins downward to impinge on the detonators.

### Precautions

1. Note that the exploder when armed is extremely sensitive to shock or motion.
2. Inspect the interior of the exploder by peering at a sharp angle through the port on the top cover. Except in extreme emergency, do not attempt rendering safe unless the rounded top of the firing pin spindle may be seen to be engaged in the recess atop the inertia frame.

### Rendering Safe Procedure

1. Remove the exploder securing bolts.
2. From a safe distance, remove the exploder, making provisions for cushioning its fall. If the exploder is armed, destroy it in situ. If unarmed, proceed as directed below.
3. Remove the L-shaped clip.
4. Unscrew the booster can.
5. Unscrew the detonator carrier keep ring (left hand threads).
6. Dispose of all explosive elements.

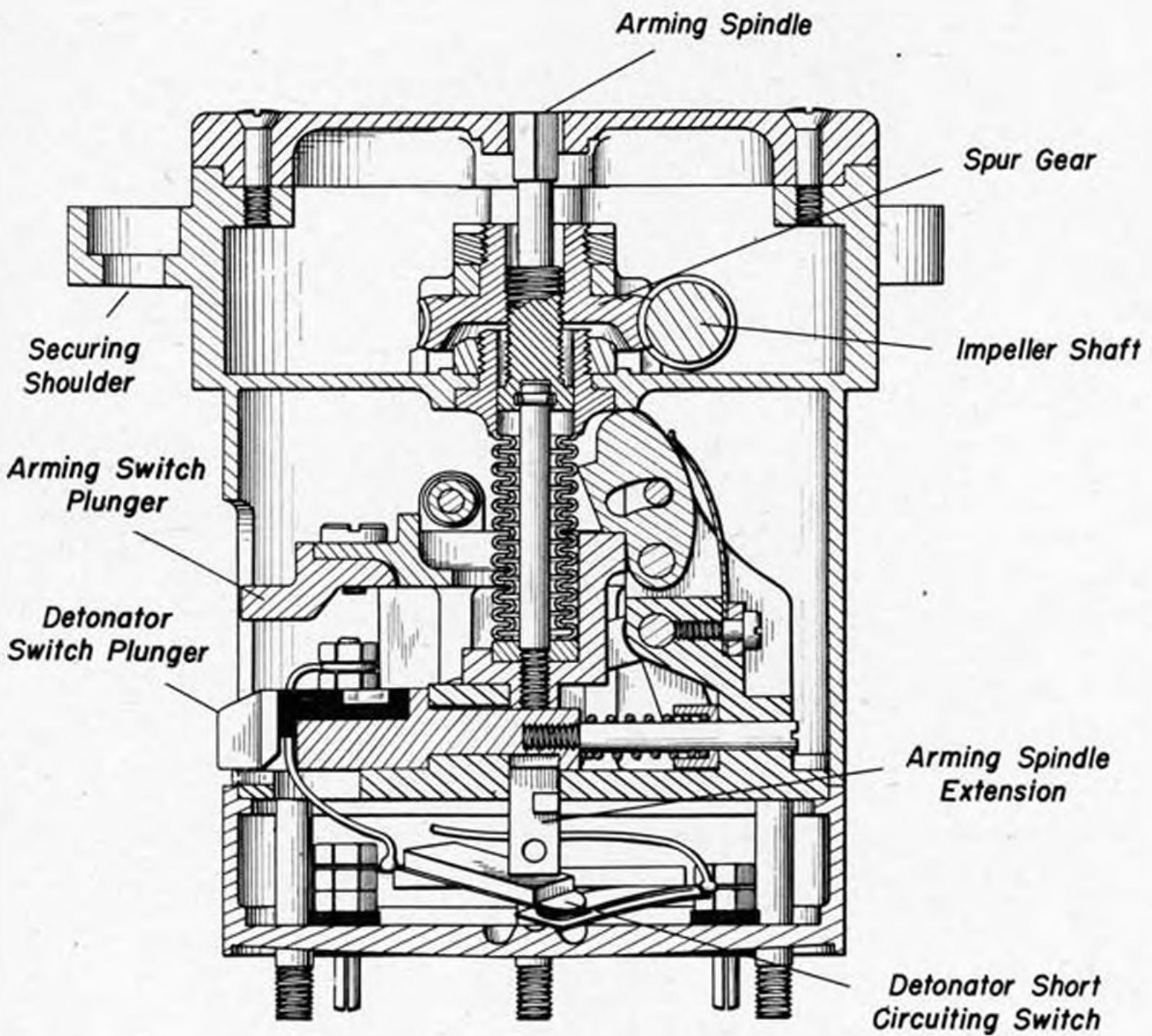

Fig. 12 - SIC Activator, Sectional View

SIC ActivatorGeneral

1. Impeller-driven arming device, fitted in transverse pocket on top center line of SIC warhead in SIC torpedoes. This device is very similar in design and operation to the German SIC activator, (Part IV, Chapter 3).

Description1. External

- (a) The activator is 16" long, 3 7/8" in maximum diameter, and is composed of the following main parts:
  - (1) An upper section, consisting of a cylindrical brass housing, 5" long, which encloses the main working parts of the device. A three-bladed impeller mounted on the end of an impeller shaft protrudes from the side of the housing and rotates in an impeller trough adjacent to the activator pocket. The top cover is made of steel, contains a square hole in its center (may be covered by a rubber diaphragm) and is secured to the housing by four screws.
  - (2) A lower section, contained in a cylindrical brass housing, 11" long and 2 1/4" in diameter, which encloses the booster and detonators.
- (b) The upper and lower sections are joined by six bolts.

2. External

- (a) The main working parts of the activator are as follows:
  - (1) The impeller and impeller shaft, the latter being fitted with a worm on its inner end which engages a spur gear.
  - (2) A threaded arming spindle which engages internal threads of the spur gear. The top of the spindle is square and fits into the hole on the top cover. The lower end of the spindle is secured to a spindle extension. A bellows is fitted around the arming spindle to keep the interior of the device water-tight.
  - (3) Two lever systems, one of which controls an arming switch plunger while the other compresses the spring of the detonator switch plunger. The arming switch plunger, consisting of a brass pin mounted on a sliding frame, is held in the unarmed position by a spring clip which bears against the arming switch plunger lever system. The detonator switch plunger, consists of two insulated, wedge-shaped contacts, each of which is fitted with an electrical lead on its upper edge. The leads go to a pair of contacts directly below the arming spindle extension and thence to the detonators. The lower end of the arming spindle extension consists of two brass prongs which, when made to the contacts mentioned above, short-circuit the detonators.

3. Method of Mounting

- (a) The activator is slipped into the warhead and secured by five lugs.

Operation

1. (a) When the torpedo is launched, impeller rotation then turns the worm and spur gears. The arming spindle, which is not free to rotate, rises up on the threads of the spur gear, carrying the spindle extension with it. As the spindle extension rises, it pivots a lever system against the tension of the spring clip, gradually forcing the arming switch plunger aft and closing the arming switch which energizes the magnetic firing device located elsewhere in the warhead.
- (b) Upward motion of the spindle extension also compresses the detonator switch plunger spring. After the arming switch plunger operates, further upward motion of the spindle extension aligns a slot in the spindle extension with detents on the detonator switch plunger, allowing the plunger to snap aft by spring pressure and make its double contact. Upward movement of the spindle extension causes the two prongs on its lower extremity to break their contacts, arming the detonator circuit.
- (c) Continued impeller rotation moves the square top of the arming spindle upward out of the square hole in the top cover, at which point upward motion of the spindle ceases since it may now rotate freely.

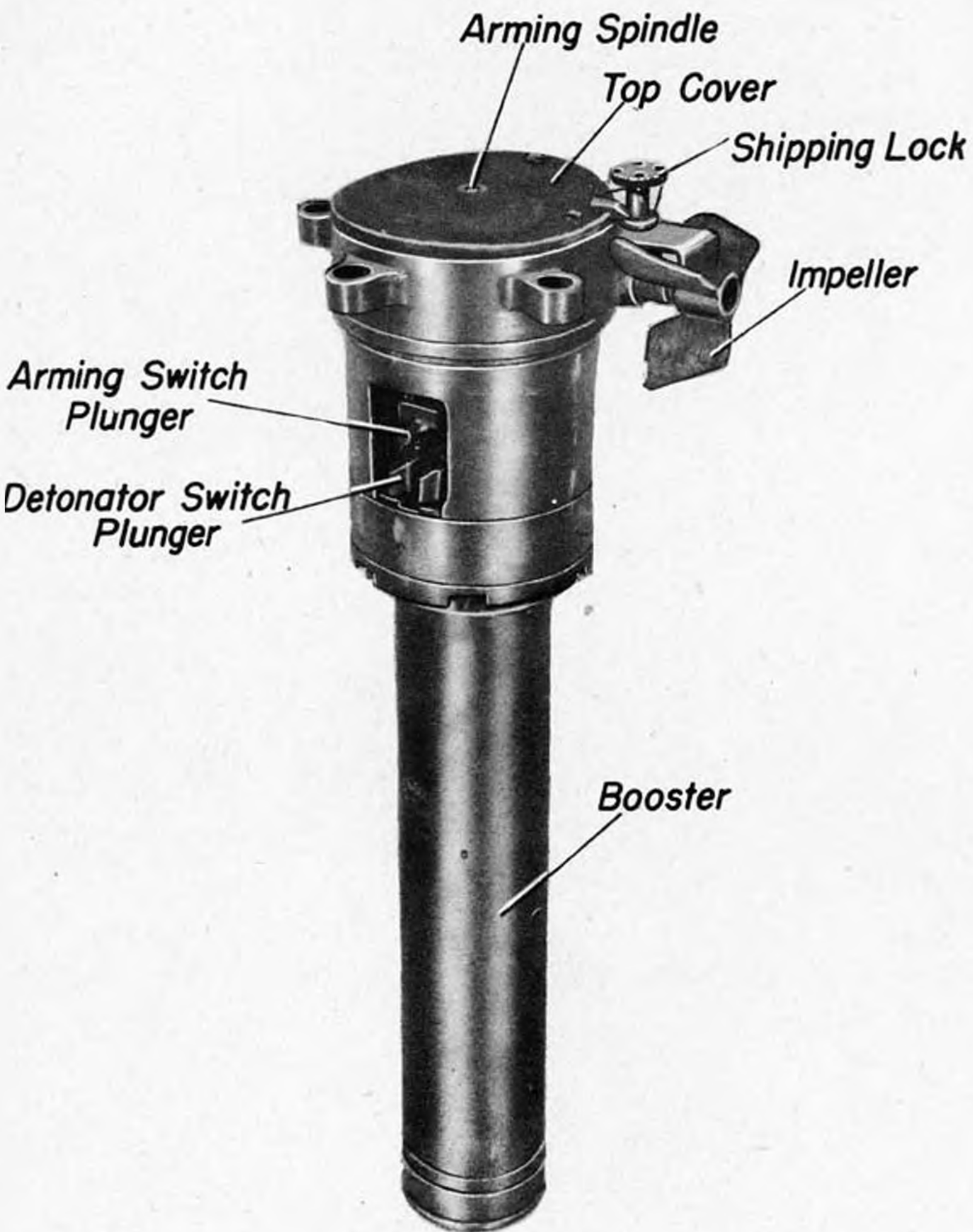

Fig.13 - SIC Activator

(SIC Activator, Cont'd.)

2. The detonators fire when the detector coils in the magnetic firing device receive the proper signal and the amplifier completes the detonator circuit from the battery.

Precautions

1. Note that this activator is used in a warhead which also contains the standard inertia type exploder in the foremost of the two pockets on the top center line. Should it be necessary to render safe a torpedo fitted with both these devices, deal with the activator first if feasible.
2. Note that the activator cannot be withdrawn from the pocket when in an armed condition.
3. The magnetic firing device may incorporate a self-destroying feature. Except in extreme emergency, wait at least 24 hours before attempting to render safe.
4. Check the condition of the activator as follows:
  - (a) If rubber diaphragm is present on top cover cut it away. Inspect the square hole in the center of the top cover. If the arming spindle projects 1/8" or more above the surface of the top cover, the magnetic firing device must be considered armed.

Rendering Safe Procedure1. Unarmed

- (a) Tape the impeller to the warhead shell.
- (b) Remove the five securing bolts.
- (c) From a safe distance, remove the activator from the warhead.
- (d) Remove the six bolts and separate the upper and lower sections.
- (e) Dispose of detonators and booster.

2. Armed

- (a) Using the proper nitric acid solution (Part I, Chapter 7), cut a hole approximately 3" in diameter on the top center line of the warhead shell, 3" abaft the after end of the activator pocket.
- (b) Slit the buff colored, rubberized cable beneath the hole; cut and tape separately each of its four leads. The magnetic section is now inert.

Note: If the inertia-type exploder has not yet been removed, it should be dealt with at this point.

- (c) Enlarge the hole until easy hand access is obtained.
- (d) Remove the keep ring which secures the switch to the after side of the activator; remove the switch.
- (e) Remove the top cover securing screws and the top cover.
- (f) Reach in through the hole and push the detonator plunger switch forward while rotating the arming spindle clockwise. Continue until the switch plunger retracts to the unarmed position.
- (g) The activator is now disarmed; proceed as in Par. 1 above.

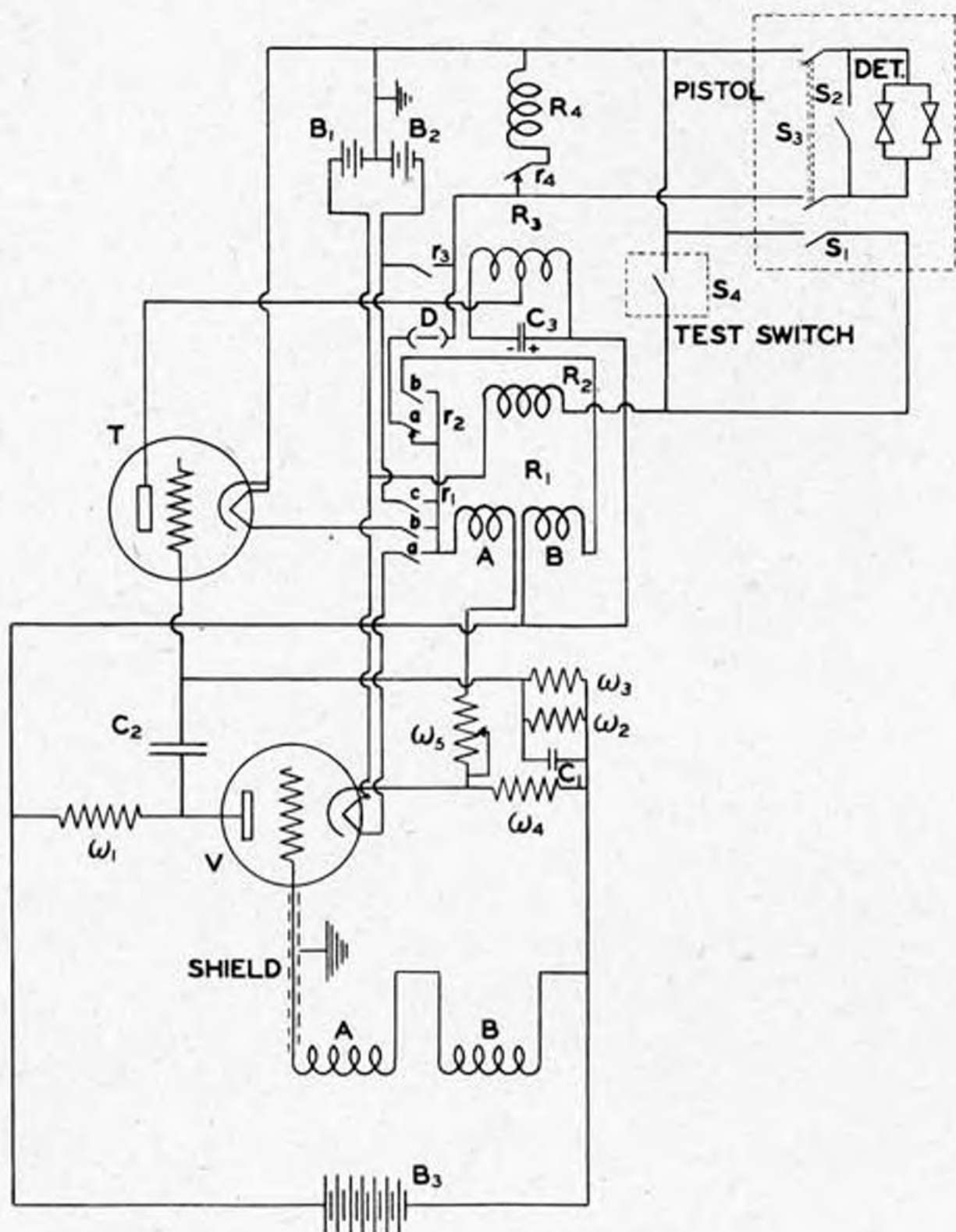

- A,B - INDUCTION DETECTOR COILS
- C<sub>1</sub> - 0.15 MFD. - 750 VOLT
- C<sub>2</sub> - 0.20 MFD. - 750 VOLT
- C<sub>3</sub> - 25.00 MFD. - 200 VOLT - ELECTROLYTIC
- B<sub>1</sub> - 4.5 VOLTS
- B<sub>2</sub> - 4.5 VOLTS
- B<sub>3</sub> - 135.0 VOLTS
- S<sub>1</sub> - ARMING SWITCH
- S<sub>2</sub> - SHORTING SWITCH
- S<sub>3</sub> - DETONATOR SWITCH
- S<sub>4</sub> - TESTING SWITCH
- D - PIN FOR SELF-DESTROYING FEATURE
- T - THYRATRON
- V - VACUUM TUBE (6Q7GT)
- ω<sub>1</sub> - 0.5 MΩ
- ω<sub>2</sub> - 2.0 MΩ
- ω<sub>3</sub> - 2.0 MΩ
- ω<sub>4</sub> - 100.0 Ω
- ω<sub>5</sub> - 700.0 Ω
- R<sub>1</sub> - RELAY (ARMING)
- R<sub>2</sub> - RELAY (ARMING)
- R<sub>3</sub> - RELAY (FIRING)
- R<sub>4</sub> - BUZZER (TESTING)

Fig. 14 - SIC Circuit

SIC Circuit - OperationArming

1. As the torpedo runs off its arming range,  $S_1$  closes,  $S_2$  opens, removing the short from the detonators, and  $S_3$  closes, putting the detonators in the firing circuit. Closing  $S_3$  causes  $B_1$  to energize  $R_2$ , causing it to operate  $r_2$ . Operation of  $r_2$  breaks (a) and makes (b), putting current from  $B_3$  through coils A and B of  $R_1$  and through  $w_5$ , thereby biasing  $w_4$ . Operation of  $R_1$  closes  $r_1$ , (a), (b), and (c), causing  $B_1$  and  $B_2$  in series to heat the cathode of V and  $B_2$  to heat the cathode of the gas-discharge tube T.

Normal Firing

1. Coils A and B are wired in series opposition so that motion of the torpedo through the earth's magnetic field produces no effect on either one. When the torpedo passes near a magnetic mass, the field around A and B is distorted in such a manner and at a sufficient rate to produce a potential between the grid of V and the negative side of  $B_3$ . This varies the plate current of V in such a manner as to produce a DC pulse across  $w_1$ . If the pulse is of the proper direction, it appears, due to the capacitative coupling, on the grid of T, allowing T to fire and complete a circuit through  $B_3$ ,  $R_3$ , the cathode of T,  $R_1A$ ,  $w_4$  and  $w_5$ .
2. When  $R_3$  is energized, it makes  $r_3$ , putting  $B_2$  across the detonators. The switch  $S_4$  and buzzer  $R_4$  are used for testing purposes only.

Self-Destroying Feature

1. Pin D is incorporated if a self-destroying feature is desired. When the circuit is armed,  $B_1$  energizes  $R_2$  constantly until the unit fires or comes to rest without firing. In the latter case,  $B_1$  eventually runs down, allowing  $R_2$  to recover gradually. When this occurs, the shorting contacts (a) and (b) are closed at the same time and  $B_2$  fires the detonators.

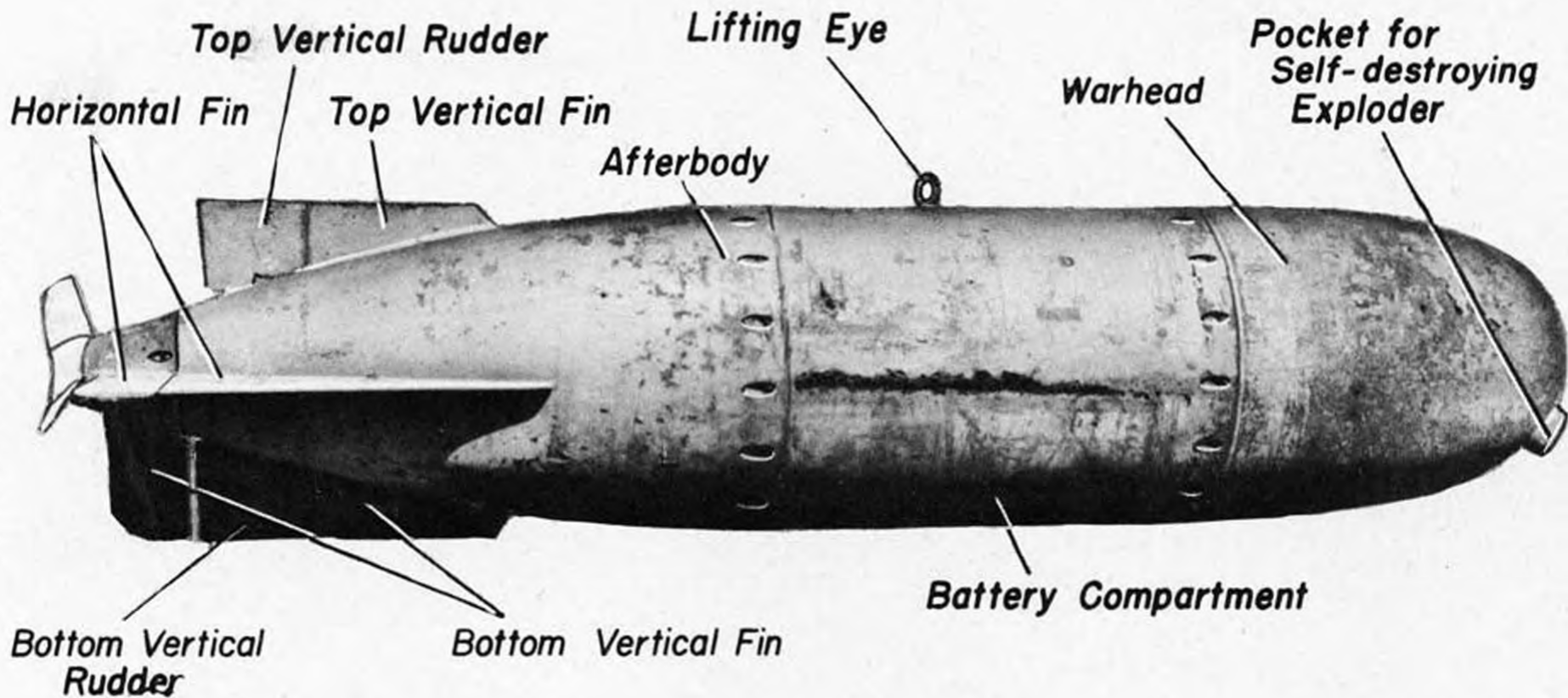

Fig. 15 - Circling Torpedo, Side View

Circling TorpedoGeneral

1. The circling torpedo is a small electrically-driven torpedo, laid with parachute from aircraft, designed to be used in harbors, anchorages and restricted waters. It is unique in the field of underwater ordnance. Although it is a self-propelled, dirigible underwater explosive weapon and is therefore a torpedo by definition, such standard torpedo components as gyro steering and depth mechanisms are omitted from its design. It is the only known torpedo to incorporate three separate exploders and, with a single exception, the only known service model to be driven by a single propeller. Aircraft launching with parachute is also unique in this field as is the torpedo's eight-foot length which is but slightly more than half that of the shortest U. S. service model.

Description

## 1. Case

Material	Steel
Color	Green
Diameter	19 1/2"
Length	
Overall	8'
Warhead	2'3"
Battery compartment	2'3"
Afterbody	2'10"
Tail	8"
Charge	200 lb. (approx.) cast Torpex
Total weight in air	927 lb.

## 2. External fittings

(a) Warhead

Direct action exploder	In pocket in center of nose.
Inertia exploder	In pocket on nose, 6 1/2" from center, 4" to port from bottom center line.
Self-destroying exploder	In pocket on nose, 6 1/2" from center, 4" to starboard from bottom center line.

(b) Battery Compartment

Suspension lug	On top center line, 10 1/2" forward of afterbody joint.
----------------	---

(c) Afterbody

Motor switch (optional)	7" to port of bottom center line, 16" abaft battery compartment joint.
-------------------------	--

(d) Tail

Propeller	Three-bladed, 10 1/2" span.
Fins	
Horizontal	Two, each 26" long, no rudders fitted.
Vertical	
Top	17 1/2" long, including rudder.
Bottom	26" long including rudder.
Parachute release	On apex of tail.

## 3. Internal arrangement of parts

(a) Warhead - no internal fittings are included.

(b) Battery Compartment - contains the propulsion battery, consisting of 1080 dry-cell batteries, wired so as to provide an EMF of about 270 volts.

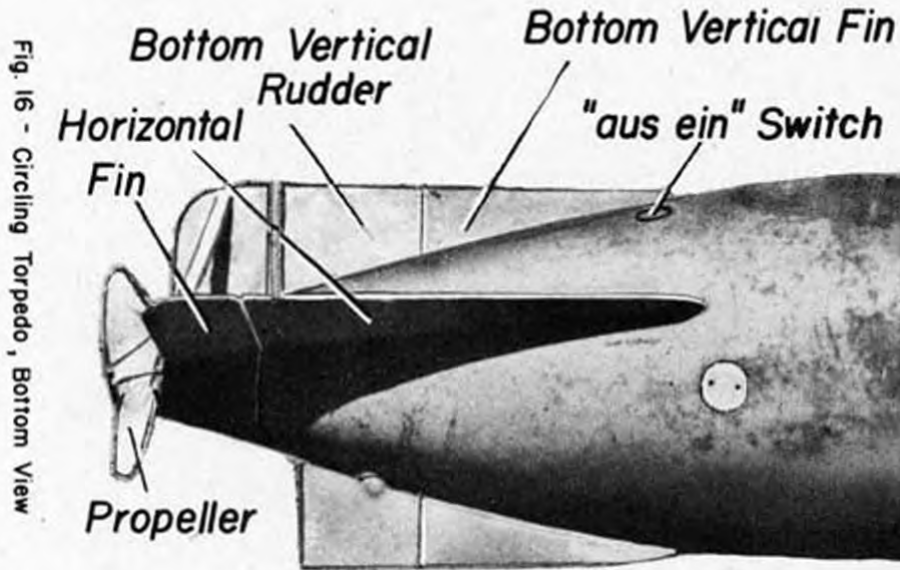

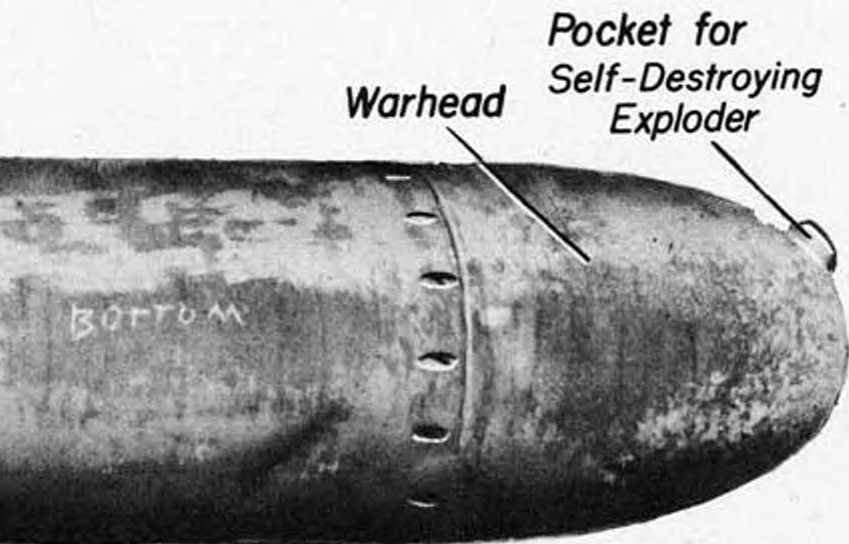

ITALIAN TORPEDOES

(Circling Torpedo, Cont'd.)

- (c) Afterbody - contains the following:
- (1) A four-pole, D. C. motor which controls a drive shaft.
  - (2) A mercury switch which controls the motor circuit.
  - (3) Steering gear which controls the vertical rudders.
- (d) Tail - contains the propeller shaft.

#### Operation

1. The motor switch on the afterbody (may not be fitted) is closed prior to launching. When the torpedo is launched, impact with the water releases tension on the parachute shrouds, thereby operating a standard German type parachute release. As the parachute ejecting plunger springs out, it permits a plunger beneath to rise and bridge two contacts in the motor circuit. The nose of the torpedo is slightly more buoyant than the after parts and tends to rise so that the torpedo body makes an acute angle with the surface of the water. When the nose has risen sufficiently, (about 20° above the horizontal), the mercury switch in the afterbody closes, completing the circuit from the battery to the motor which starts to run.
2. The torpedo then runs, broaching slightly, at a speed of five to six knots. Its course varies with the type of cam fitted to the steering gear but is almost always some derivative of a circle. The torpedo may then fire by means of the impact-inertia exploder, the impact-direct action exploder or the self-destroying exploder. In some cases, a second impact-inertia exploder may be fitted in place of the self-destroying exploder, in which instances the torpedo becomes a very sensitive impact-inertia floating mine at the end of its run. Details of each pistol are discussed below.

#### Precautions

1. Never attempt rendering safe by disassembly or removal of the exploders. The extreme sensitivity of the inertia exploder(s) when armed makes such a procedure suicidal. The armed or unarmed condition of an exploder cannot be determined from an exterior examination.
2. Countermine the torpedo in situ if at all feasible. If countermining is not compatible with the local military situation, it may be possible to shear the nose of the warhead, including exploders, from the after part using a curvelinear cavity charge (Part I, Chapter 5). It should be noted, however, that this procedure has not been field tested and a high order detonation must be anticipated.

#### Rendering Safe Procedure

1. None recommended.



Fig. 17 - Circling Torpedo Warhead

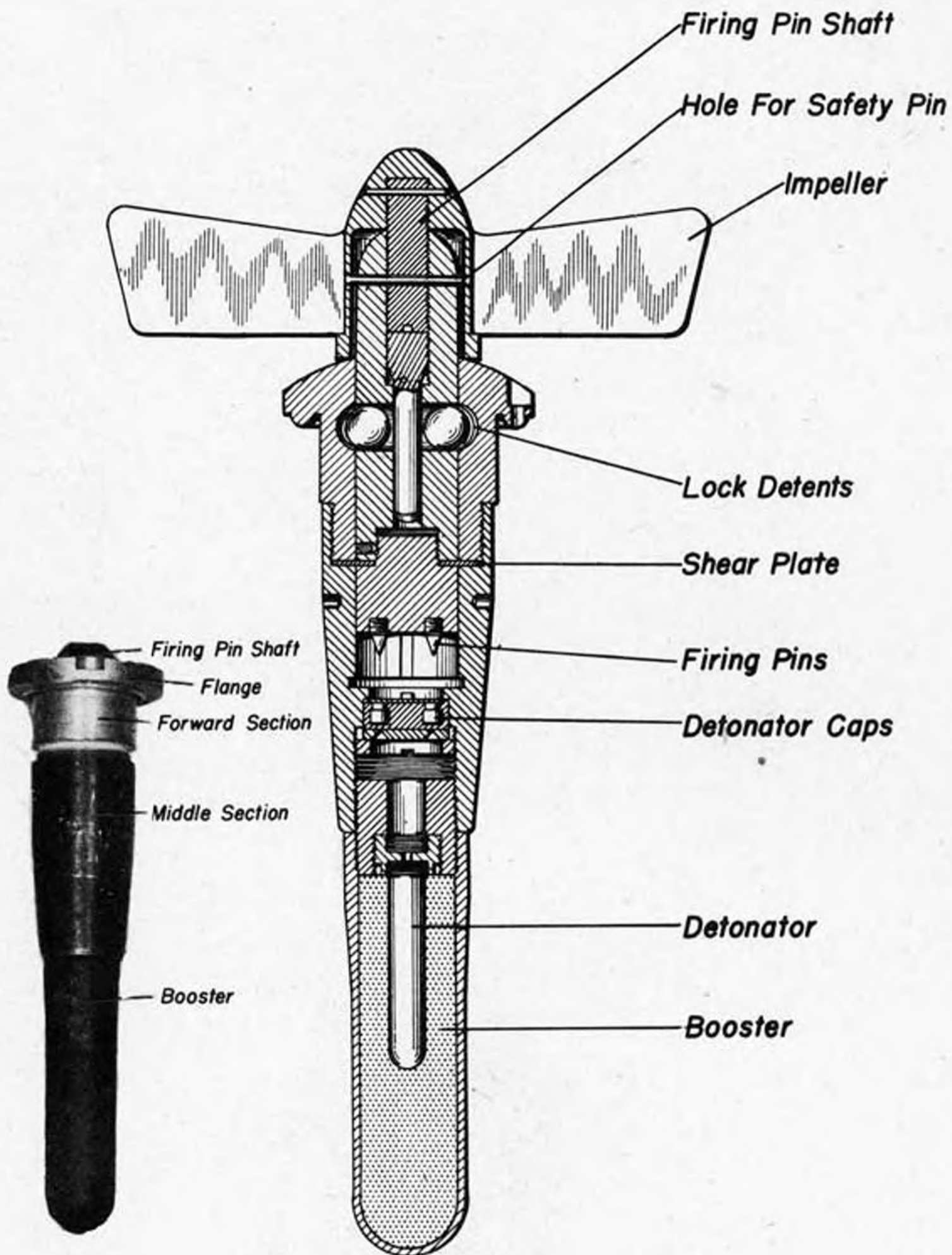

Fig. 18 - Impact Direct Action Exploder, for Use in Circling Torpedo

Fig. 19 - Impact Direct Action Exploder, for Use in Circling Torpedo, Sectional View

Impact-Direct Action ExploderGeneral

1. Used in circling torpedo.

Description1. External

- (a) The exploder is generally cylindrical in shape, approximately 12" long, 3" in maximum diameter, and is composed of the following main parts:
- (1) A forward section, which protrudes from the warhead, consisting of a flanged sleeve and a firing pin shaft, rounded at its forward end, which slides into the center of the flange. The forward end of the firing pin shaft is enclosed by a cap fitted with a four-bladed impeller. This section contains the exploder arming and firing devices.
  - (2) A middle section which contains the firing pins and detonator caps.
  - (3) An after section which contains the detonator and booster.
- (b) The various exploder sections are screwed together, a small adapter being used to join the middle and after sections.

2. Internal

- (a) The primary working parts of the exploder are as follows:
- (1) The impeller which is keyed to an arming spindle which in turn screws into the firing pin shaft.
  - (2) The firing pin shaft which contains the firing pins on its after end and which is held in the unarmed position by:
    - (1) Lock detents held by the lower end of the arming spindle.
    - (11) A small shear plate at the joint between the forward and middle sections.

3. Method of Mounting

- (a) The exploder may be either screwed into the warhead or secured by three bolts depending on the design.

Operation

1. A safety pin through the impeller cap and firing pin shaft is removed prior to launching. When the torpedo is launched, air and water travel rotate the impeller. Impeller rotation unscrews the arming spindle from the firing pin shaft, thereby freeing the locking detents. Impeller rotation continues until the impeller disengages the firing pin shaft and drops free. The exploder is now armed.
2. Impact with a hard surface forces the firing pin shaft inward, shearing the shear plate and forcing the firing pins onto the detonator caps, which in turn fire the detonator.

Impact-Inertia ExploderGeneral

1. Used in circling torpedo.

Description1. External

- (a) The exploder is generally cylindrical in shape, approximately 15" long, 3" in maximum diameter and is composed of the following main parts:
- (1) A forward section, which protrudes from the warhead, consisting of a flanged sleeve and a cylindrical nose piece, rounded at its forward end, which screws into the center of the flange and is fitted with an impeller. This section contains the exploder safety arming devices and the inertia firing mechanism.

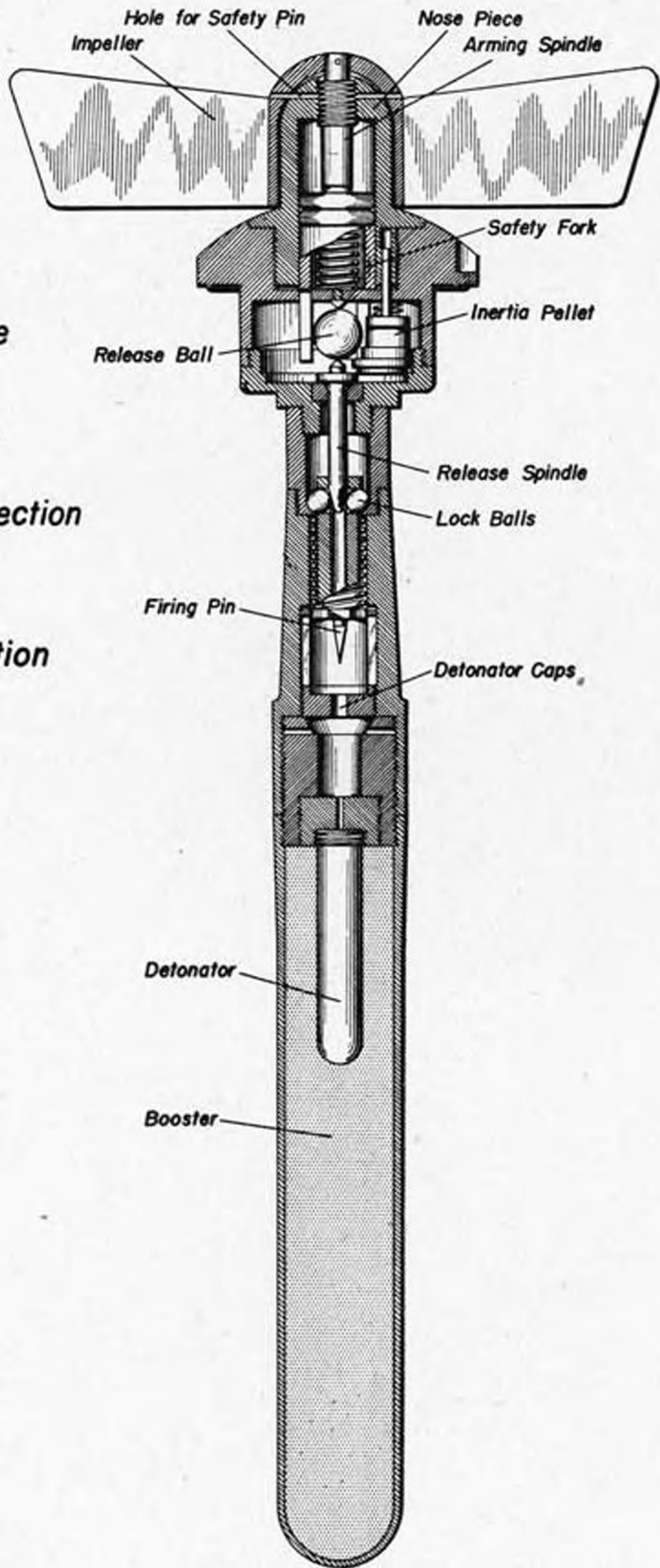

Fig. 20 - Impact Inertia Exploder,  
for Use in Circling Torpedo

Fig. 21 - Impact Inertia Exploder  
for Use in Circling Torpedo,  
Sectional View

(Impact-Inertia Exploder, Cont'd.)

- (2) A middle section, consisting of two sleeves screwed together, which contains the spring-loaded firing pin assembly, the firing pin release and the detonator caps.
- (3) An after section which contains the detonator and booster.
- (b) The various exploder sections are screwed together, a small adapter being used to join the middle and after sections.

2. Internal

- (a) The primary working parts of the exploder are as follows:
  - (1) The impeller which is attached to an arming spindle which in turn screws into the nose piece.
  - (2) A spring-loaded safety fork which is restrained by the arming spindle.
  - (3) A steel release ball, held between two small support points, is restrained prior to arming by the safety fork prongs.
  - (4) A spring-loaded inertia pellet.
  - (5) The spring-loaded firing pin assembly, restrained by lock balls which are in turn held by the lower end of the release spindle. The upper end of the release spindle tapers to form the lower support point for the release ball.

3. Method of Mounting

- (a) The exploder is screwed into the warhead.

Operation

1. When the torpedo is launched, water impact shears a safety pin in the impeller. Water travel rotates the impeller, thereby unscrewing the impeller from the nose piece, withdrawing the arming spindle and allowing the spring-loaded safety fork to move outward and disengage the release ball. The impeller and arming spindle drop free and the exploder is armed.
2. The exploder fires when subjected to a slight inertia force. This displaces the inertia pellet which pushes the release ball from between its two support points. Movement of the ball frees the release spindle which is forced forward by the pressure of the lock balls on its tapered lower end, releasing the lock balls and allowing the spring-loaded firing pins to impinge on the detonator caps which in turn fire the detonators.

Self-Destroying ExploderGeneral

1. Used in circling torpedo.

Description1. External

- (a) The exploder is generally cylindrical in shape, approximately 15" long, 3" in maximum diameter, and is composed of the following main parts:
  - (1) A forward section, which protrudes from the warhead, consisting of a flanged sleeve and a cylindrical nose piece, rounded at its forward end, which screws into the center of the flange and is fitted with an impeller. This section contains the exploder safety arming devices.
  - (2) A middle section, consisting of two sleeves joined by a threaded adapter, which contains the spring-loaded firing pin assembly, the firing pin release and the detonator caps.
  - (3) An after section which contains the detonator and booster.
- (b) The various exploder sections are screwed together, a small adapter being used to join the middle and after sections.

2. Internal

- (a) The primary working parts of the exploder are as follows:

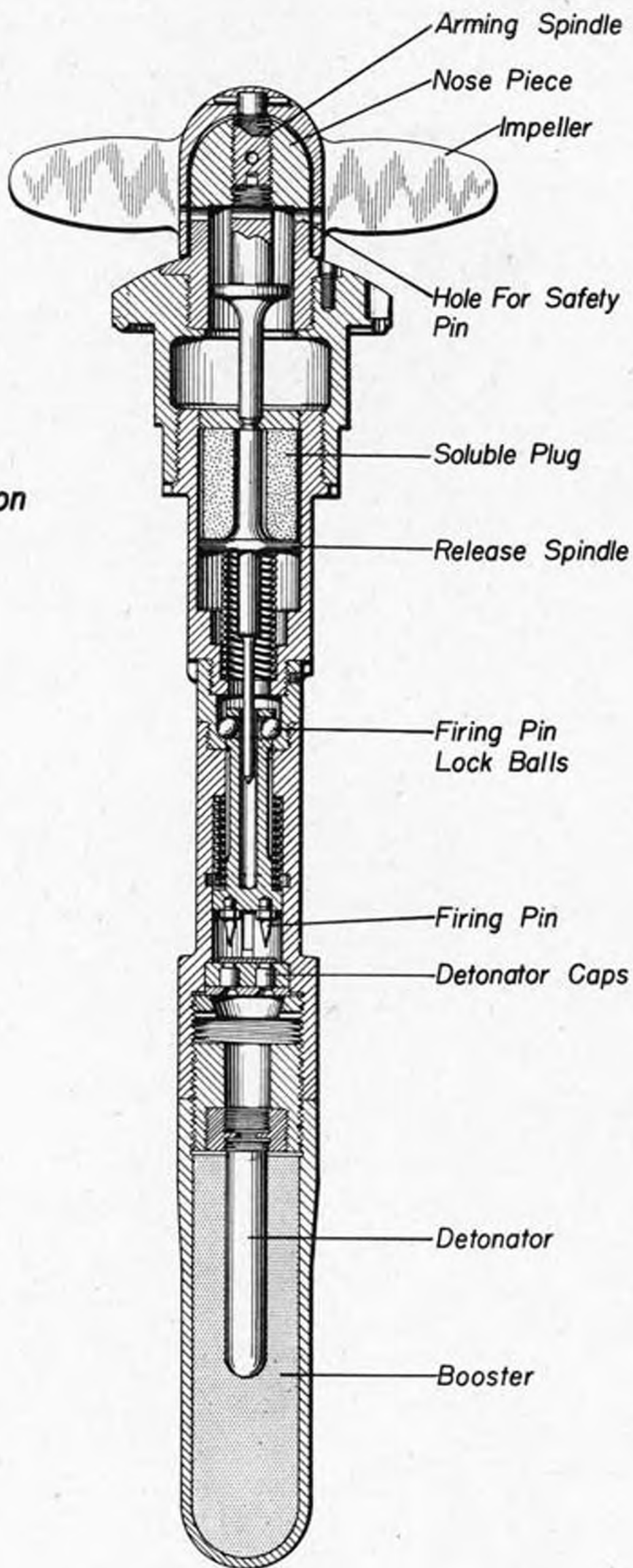
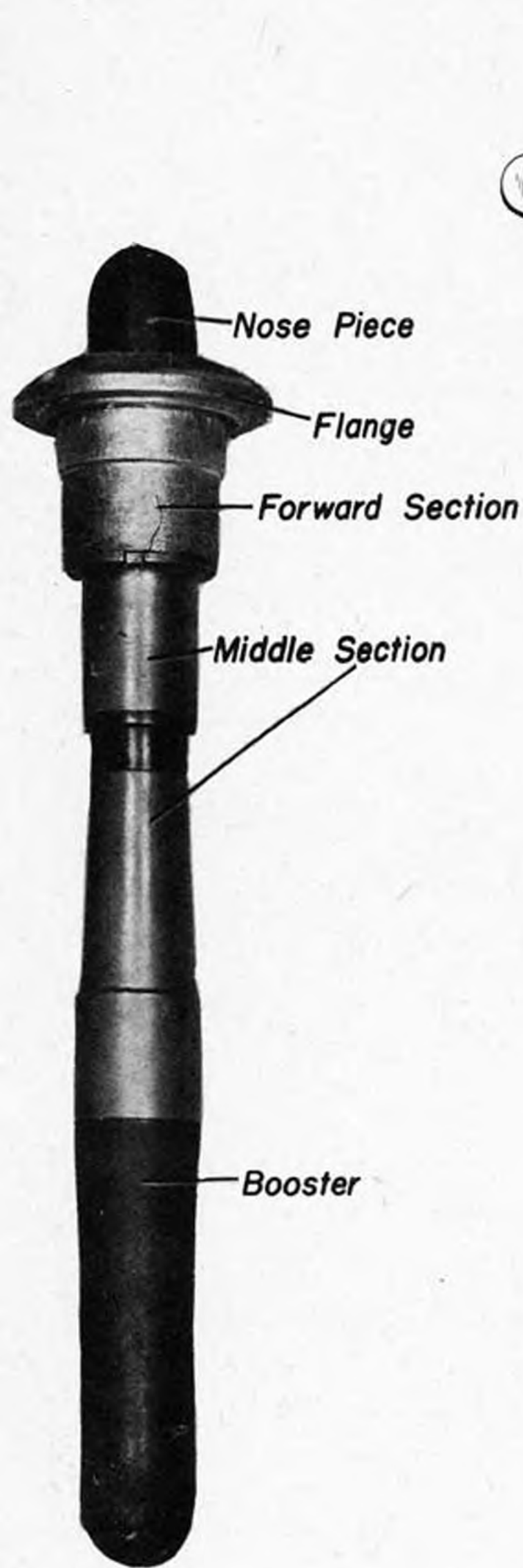

Fig. 22 - Self Destroying Exploder,  
for Use in Circling Torpedo

Fig. 23 - Self Destroying Exploder,  
for Use in Circling Torpedo,  
Sectional View

## (Self-Destroying Exploder, Cont'd.)

- (1) The impeller which is attached to an arming spindle which in turn screws into the nose piece.
- (2) The spring-loaded firing pin assembly.
- (3) The spring-loaded release spindle, the after end of which protrudes into the forward end of the firing pin and restrains the firing pin lock balls. Its forward end is held by the after end of the arming spindle and its forward movement is also restrained by a soluble plug.

3. Method of Mounting

- (a) The exploder is screwed into the warhead.

Operation

1. A safety pin through the impeller and nose piece is removed prior to launching. When the torpedo is launched, air and water travel rotate the impeller, thereby unscrewing the impeller and arming spindle from the nose piece and leaving the release spindle restrained only by the soluble plug. The impeller and arming spindle drop free and the exploder is armed.
2. Gradual dissolution of the soluble plug permits the spring-loaded release spindle to move forward until it clears the firing pin lock balls, releasing the lock balls and allowing the spring-loaded firing pins to impinge on the detonator caps which in turn fire the detonator.

# MINE DISPOSAL HANDBOOK

## PART V

### ITALIAN UNDERWATER ORDNANCE

. . . . .

#### CHAPTER 3

#### ITALIAN DEPTH CHARGES

Depth  
Charges

## ITALIAN DEPTH CHARGES

### Introduction

1. No Italian depth charges have ever been made available for examination by the U.S. Navy and the following information, being drawn almost entirely from captured documents, may not be entirely reliable and should be accepted with reserve. The Tactical Depth Charge, which has been recovered and examined, is not a depth charge in the usual sense but is included herein because of its similarity in appearance.
2. This chapter contains information on two standard depth charge cases, each of which is made in two sizes, and two depth charge pistols. Both the pistols operate on direct hydrostatic pressure in a manner similar to U.S. pistols. The depth charge cases incorporate a unique design feature wherein a small electrolytic cell may be used to flood the charge if it fails to detonate as designed during descent.
3. The following precautions should generally be observed when dealing with Italian depth charges:
  - (a) Do not move or jar the charge except from a safe distance.
  - (b) Do not change the depth setting while rendering safe.
  - (c) If the charge is found underwater, raise it to the surface before rendering safe.

### 1927 Model Depth Charge

#### General

1. Launched by surface craft.
2. Italian designation, "Bombe Torpedine da Getto 50/1927 (or 100/1927) I. A.". (The numbers 50 and 100 above refer to the weight of charge in kilograms cast in the respective cases which differ only in diameter.)

#### Description

##### 1. Case

Shape	Cylindrical, enclosed at each end by welded steel heads.
Color	Gray
Material	Steel
Diameter	11" (50 kg) or 15" (100 kg).
Length	20" approx.
Charge	110 lb. or 220 lb. cast TNT.
Total weight in air	Unknown

##### 2. External fittings

Lifting eyes	Two, 90° apart, on pistol end.
Filling holes	Two, 90° apart, on pistol end, 90° from lifting eyes.

##### 3. Standard Accessories for Case

- Pistol - Type B.
- Booster - Type A with booster extender.
- Standard flooder.

#### Rendering Safe Procedure

1. Using an adjustable wrench or other suitable tool, remove the pistol from the case.
2. Remove the booster extender.
3. Dispose of detonator, booster and charge.

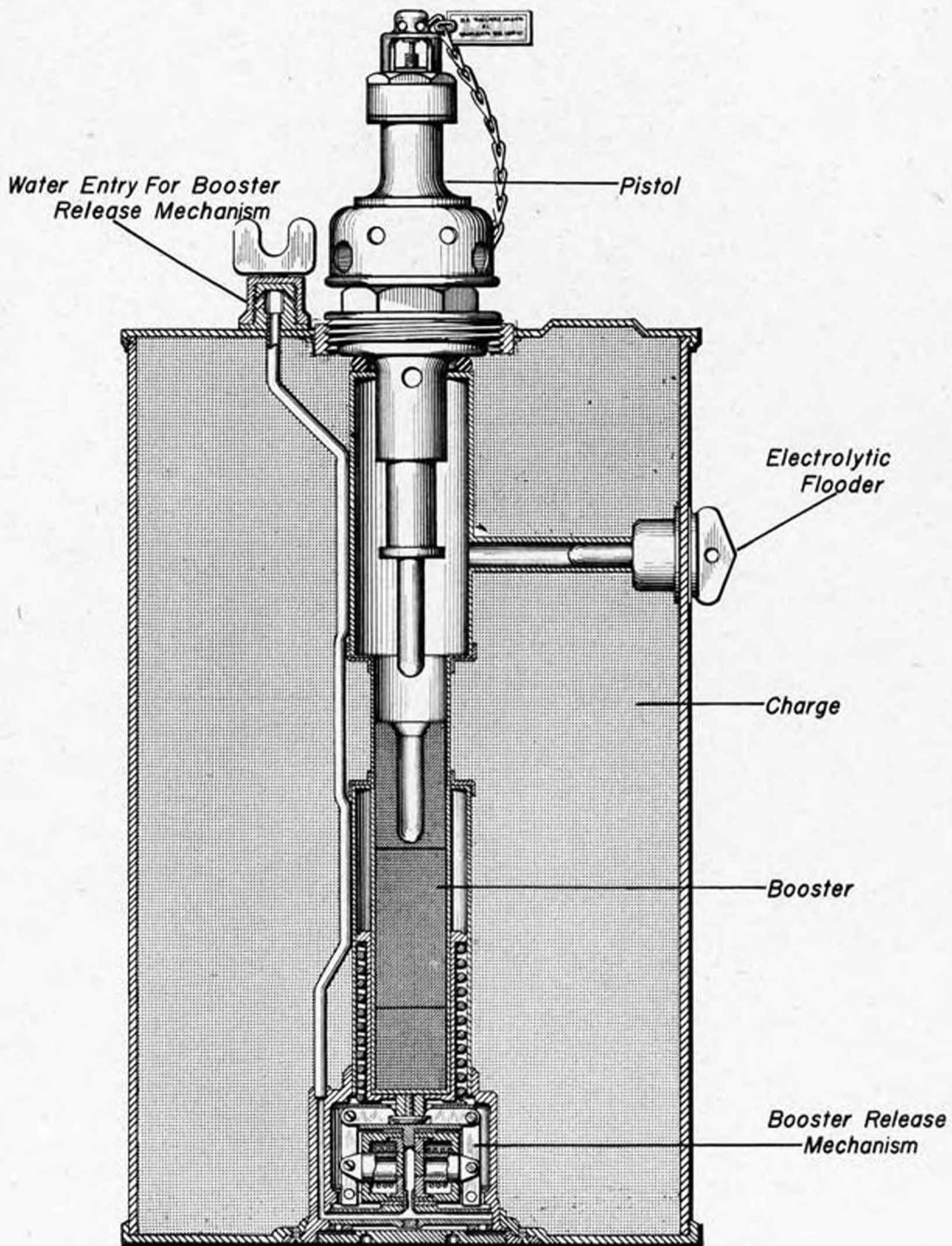

Fig. 1 - 1936 Model Depth Charge, Sectional View.

ITALIAN DEPTH CHARGES

1936 Model Depth Charge

General

1. Launched from surface craft.
2. Italian designation, "Bombe Torpedine da Getto 50/1936 (or 100/1936) I. A., I. B.". (The numbers 50 and 100 above refer to the weight of charge in kilograms cast in the respective cases which differ only in diameter.)

Description

1. Case

Shape	Cylindrical, enclosed at each end by welded steel heads.
Color	Gray
Material	Steel
Diameter	11" (50 kg) or 15" (100 kg).
Length	20" approx.
Charge	110 lb. or 220 lb.
Total weight in air	Unknown

2. External fittings

Lifting eyes	Two, 90° apart, on pistol end.
Filling holes	Two, 90° apart, on pistol end, 90° from lifting eyes.
Water inlet	Adjacent to pistol, covered by screw cap prior to launching.

3. Standard Accessories for Case

- Pistol - Type A.
- Booster - Type B with booster release mechanism.
- \* Standard flooder.

Rendering Safe Procedure

1. Same as 1927 Model.

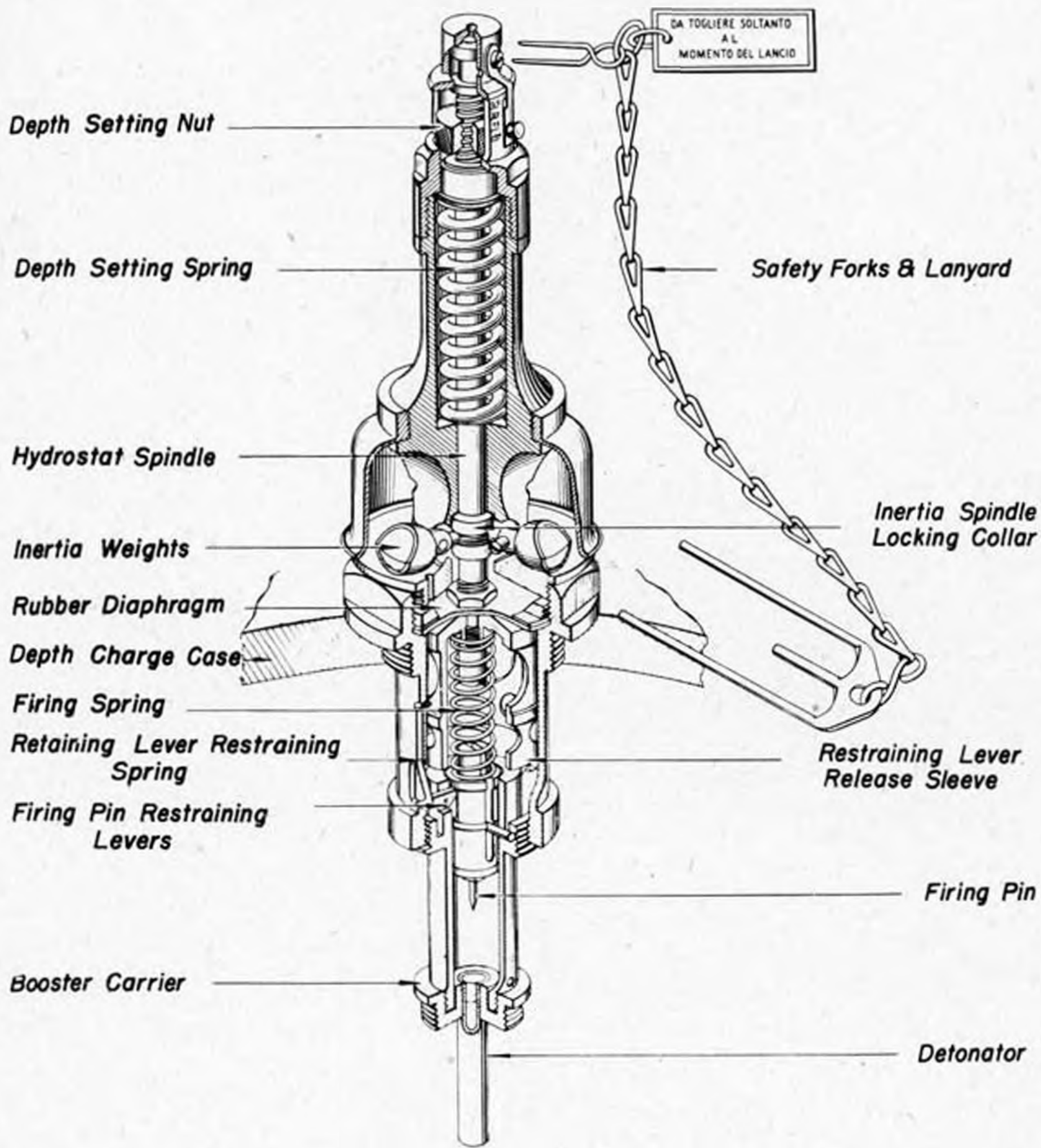

Fig. 2 - Depth Charge Pistol Type A, Sectional View.

## ITALIAN DEPTH CHARGES

### Type A Pistol

#### General

1. Hydrostatic, direct action type, used in depth charges launched from surface craft.

#### Description

##### 1. External

- (a) The pistol is 12 3/4" long, 3 1/4" in diameter at its center flange, and is composed of the following main parts:
  - (1) An upper section which protrudes about 7 1/2" from the depth charge case and which houses the pistol depth-setting gear. Depth settings of 25, 50, 75 and 100 (meters) are inscribed at the top. Two safety forks are fitted prior to launching, one at the top to lock the hydrostatic spindle and one at the base near the flange to lock the inertia weights.
  - (2) A lower section which is housed in the depth charge and which contains the firing mechanism and the detonator.
- (b) The two sections are joined at a flange about midway on the pistol body.

##### 2. Internal

- (a) The main working parts of the pistol are as follows:
  - (1) A hydrostatic spindle, the lower end of which protrudes through and is controlled by a rubber diaphragm. The spindle contains an annular groove on its lower portion just above the diaphragm.
  - (2) A depth-setting spring encloses the hydrostatic spindle and tends to force the spindle upward.
  - (3) A depth-setting nut screwed to the upper end of the hydrostatic spindle adjusts tension on the depth-setting spring.
  - (4) Three pivoted inertia weights are mounted around the inside of the pistol housing and are so arranged that their inner edges will engage the annular groove on the hydrostatic spindle upon actuation.
  - (5) A firing pin housing, screwed into the lower pistol body, contains a spring-loaded firing pin assembly which is held in the unfired position by two triangular pivoted restraining levers. The levers are held against the spindle by two leaf springs on the outside of the pistol body and are so attached that they can pivot only in one direction.
  - (6) A restraining lever release sleeve is attached to the hydrostatic spindle directly below the diaphragm.

##### 3. Method of Mounting

- (a) The pistol is screwed into the central tube of the depth charge case.

#### Operation

1. The depth setting is made manually prior to launching by screwing down on the depth-setting nut until its top is flush with the mark at the desired setting. Removal of the safety forks unlocks the hydrostatic spindle and inertia weights. When the charge is launched, hydrostatic pressure depresses the diaphragm, thereby depressing the hydrostatic spindle against the tension of the depth-setting spring. This depresses the restraining lever release sleeve and compresses the firing spring and, when the depth charge reaches the firing depth, the lever release sleeve pivots the levers upward until they clear a small flange on the firing spindle and allow the spring-loaded firing pin to impinge on the detonator.
2. If the depth charge is subjected to a sudden shock of considerable magnitude at any time after launching, the ends of the inertia weight arms engage the annular groove on the hydrostatic spindle, locking the spindle.

### Type B Pistol

1. This pistol differs from the Type A only in that no inertia weights are fitted.

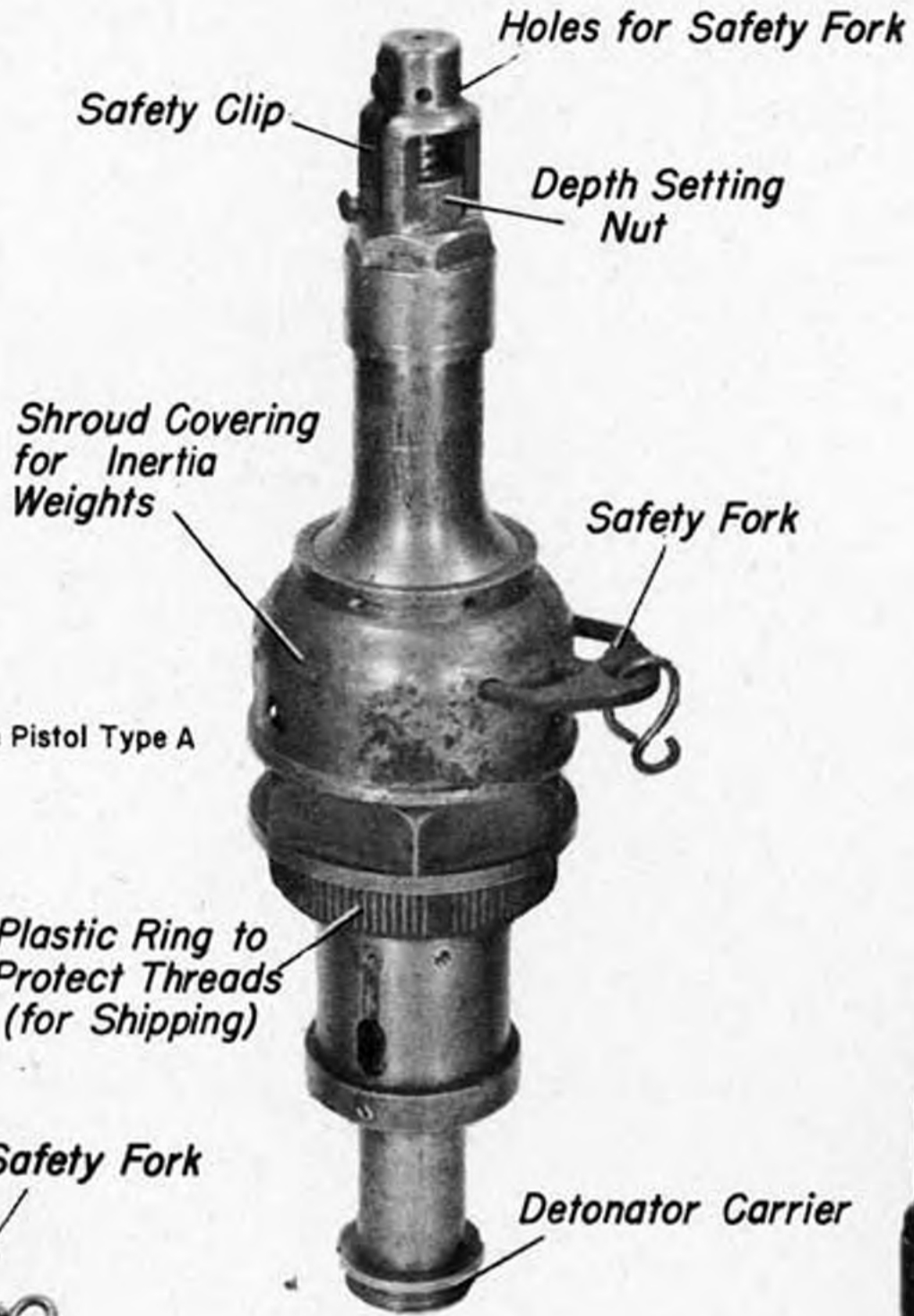

Fig. 3- Depth Charge Pistol Type A



Fig. 5- Depth Charge Pistol Type B.



Fig. 4- Depth Charge Pistol Type A, Shroud Covering Removed.

## ITALIAN DEPTH CHARGES

### Boosters

#### Type A

1. This booster consists of three cylinders of pressed TNT enclosed in a metal case. The upper cylinder contains a detonator envelope. A threaded ring is welded to the lower end of the booster container and screws to the inner end of the booster extender spindle.

#### Type B

1. This booster consists of four cylinders of pressed TNT enclosed in a metal case. One of the upper cylinders contains a detonator envelope. The lower end of the booster container is fitted with a mushroom-headed disc which is engaged by pawls on the booster release mechanism.

### Booster Extender Mechanism

1. This mechanism, housed in a cylindrical case, consists of a hydrostatically-operated diaphragm attached to a spring-loaded spindle. The spindle spring tension opposes hydrostatic pressure and tends to force the diaphragm outward.
2. When the depth charge is launched, hydrostatic pressure acting against the tension of the spindle spring forces the diaphragm, and thereby the spindle and booster, in toward the detonator until, at a depth of about 12 ft., the detonator is completely housed in the booster.

### Booster Release Mechanism

1. This mechanism, housed in a cylindrical case, consists of two pistons held against two hydrostatically-operated diaphragms. The inner end of each piston is attached to the mid-point of an L-shaped lever, one end of which engages the mushroom head on the booster can.
2. When the depth charge is launched, water enters the mechanism through the water inlet on the top of the depth charge case and flows down to the booster end through a special channel. Hydrostatic pressure then forces the diaphragms apart, causing the pistons to pivot the L-shaped levers and release the spring-loaded booster to house over the detonator.

### Flooder Device

1. This device, designed to flood the depth charge case if the charge fails to detonate as designed, consists of a zinc-copper electrolytic cell fitted at the outer end of a small channel which runs from the central tube to the side of the mine case. Use of the device is optional.
2. If the flooder is to be used, a plug is removed from the outer end of the channel on the side of the case and the tinfoil seal is punctured to admit water to the cell. If the depth charge fails to fire properly, the admission of water to the cell corrodes a watertight zinc plug within 48 hours after immersion, admitting water to the central tube of the depth charge. This equalizes the pressure inside and outside and thereby disarms the pistol and separates the booster and detonator if the booster extender is used.

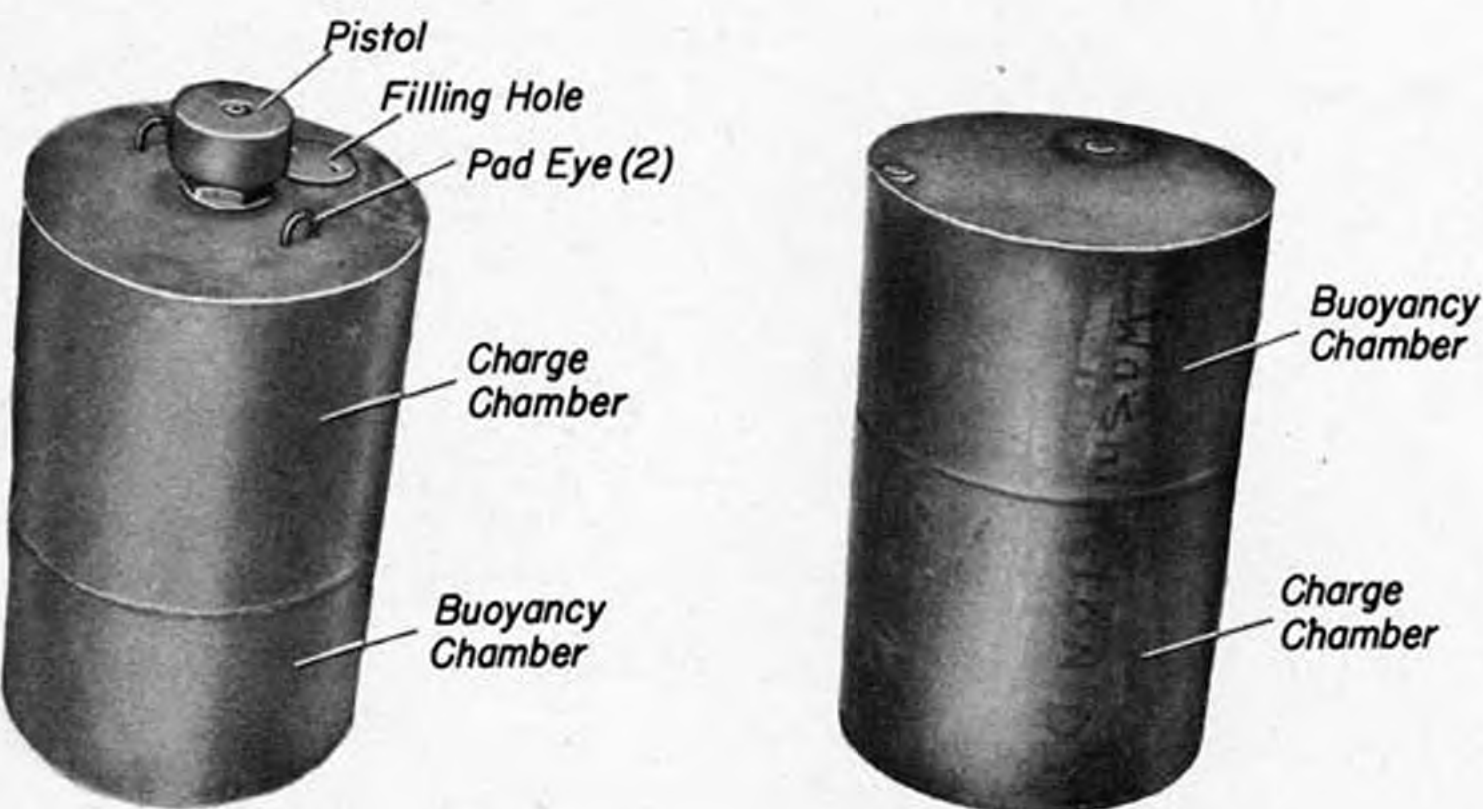

Fig. 6 - Tactical Depth Charge.



Fig. 7 - Pistol for Tactical Depth Charge.

ITALIAN DEPTH CHARGES  
Italian Tactical Depth Charge

General

1. Buoyant, tactical explosive charge, launched from surface craft.
2. Italian designation unknown.
3. Used defensively by surface craft to harass pursuing surface units. Designed to force pursuing ships to keep at a safe distance from the charges and thus give the pursued ship a tactical advantage.

Description

1. Case

Shape	Cylindrical
Color	Brown
Material	Steel
Diameter	14"
Length	21 3/4"
Charge	120 lb. Hexanite (approx)
Total weight in air	157 lb. approx.

2. External fittings

Lifting eyes	Two, 90° apart on pistol end, 3 3/4" from center.
Filling hole	2 1/4" diam., on pistol end, 90° from lifting eyes, 4" from center.

3. The pistol fitted is very similar to the Type A pistol, the main difference being that an 8 1/2 lb. lead weight and weight release mechanism are fitted to the outer end of the hydrostatic spindle of the pistol. It is assumed that a delay detonator is fitted in place of the standard instantaneous detonator.

Operation

1. When the charge is launched, its slight negative buoyancy causes it to sink slowly. At a set depth, believed to be about 18 ft., hydrostatic pressure depresses the spindle fully, performing the following functions:
  - (a) It operates the weight release mechanism, releasing the weight and thereby giving the case a slight positive buoyancy.
  - (b) It releases the firing pin, thereby firing the delay detonator.
2. The positive buoyancy then causes the case to rise and, at the end of its set delay period, the detonator fires the charge. It is believed that the charge case is 3-5 ft. below the surface when the charge fires.

Precautions

1. Check the condition of the pistol.
  - (a) If the lead weight is still attached, the pistol may be assumed to be safe.
  - (b) If the lead weight is not attached, the detonator must be assumed to have fired and the charge is in a dangerous condition.

Rendering Safe Procedure

1. Using an adjustable wrench or other suitable tool, remove the pistol from the case.
2. Unscrew the detonator from the pistol.
3. Remove the booster.
4. Dispose of detonator, booster and charge.

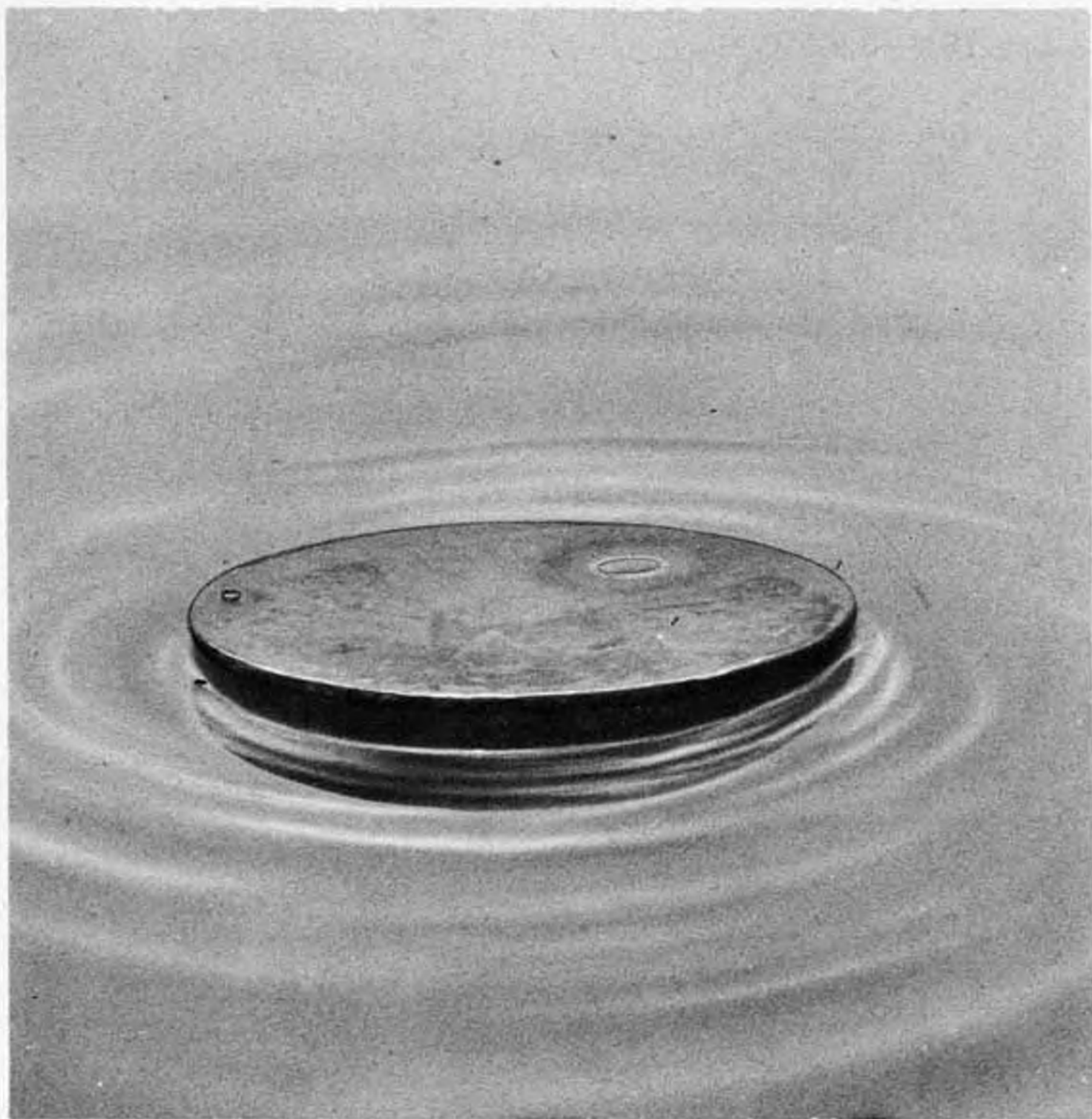

Fig.8 - Tactical Depth Charge Floating.

# MINE DISPOSAL HANDBOOK

## PART V

### ITALIAN UNDERWATER ORDNANCE

. . . . .

#### CHAPTER 4

#### ITALIAN MISCELLANEOUS

Misc.

Controlled Mine Type OGeneral

1. Controlled ground mine, laid by surface craft.
2. Italian designation, "Controlled Mine Type O".
3. Defensive mine, for use in maximum depth of water of 165 ft.

Description

## 1. Case

Shape	Spherical
Color	Black
Material	Steel
Diameter	33"
Charge	880 lb. cast Trotyl.
Total weight in air	3256 lb. (includes anchor)

## 2. External fittings

Cover plate	In center of upper hemisphere, fitted with arming hydrostat.
Firing cable stuffing box	On upper hemisphere.
Lifting lugs	Two on upper hemisphere, 180° apart.

Operation

1. When the mine is launched, dissolution of a soluble plug allows the arming hydrostat to depress the detonator carrier which then performs the following arming functions:
  - (a) It completes the firing circuit.
  - (b) It operates the booster release mechanism.
2. The mine is fired electrically by an observer.
3. The only self-disarming device is the arming hydrostat which is designed to disarm the mine by opening the firing circuit if the mine rises above a depth of 10 ft.

Precautions

1. See Introduction.

RMS

1. Slit the firing cable; cut and tape each lead separately.
2. Unscrew the keep ring and remove the arming hydrostat; the detonator is attached thereto.
3. Press back the booster latch and remove the booster.
4. Dispose of detonator, booster and charge.

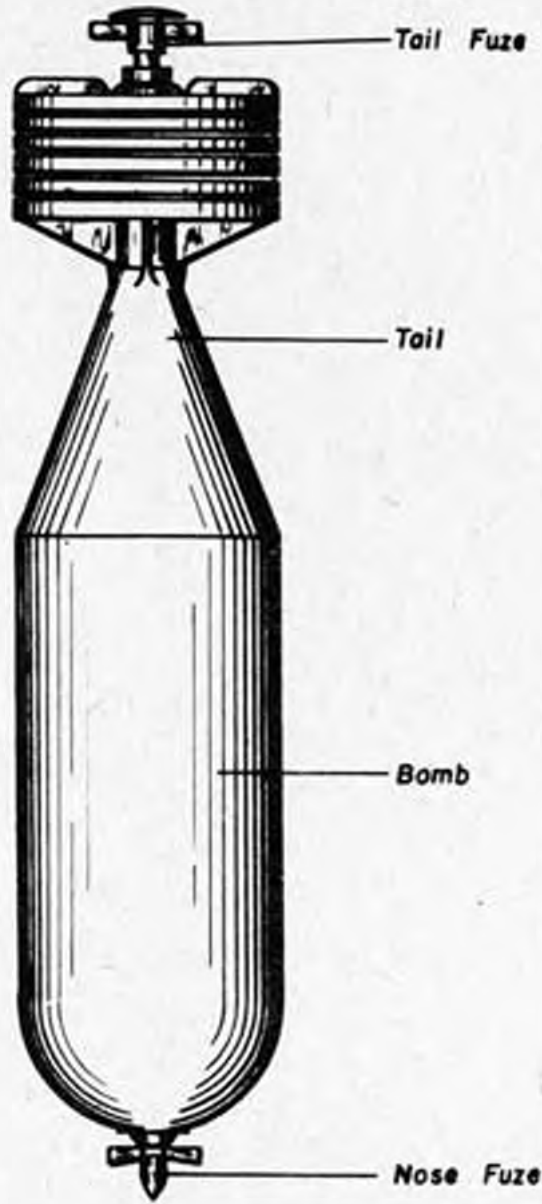

Fig. 1 - 160/C.S. Depth Bomb

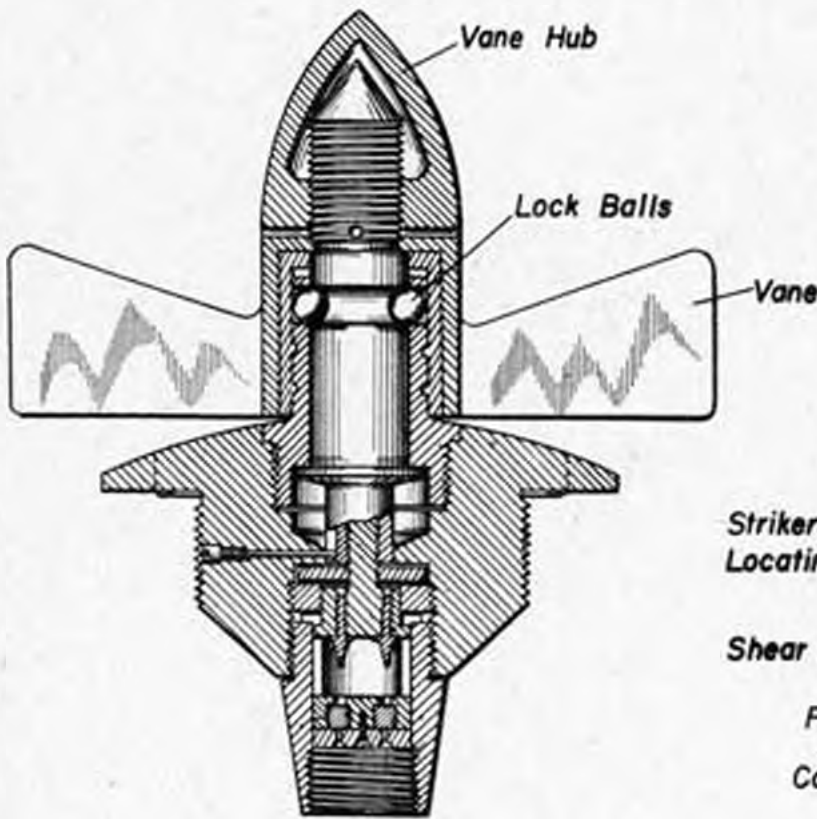

Fig. 2 - Type B Nose Fuze  
Sectional View

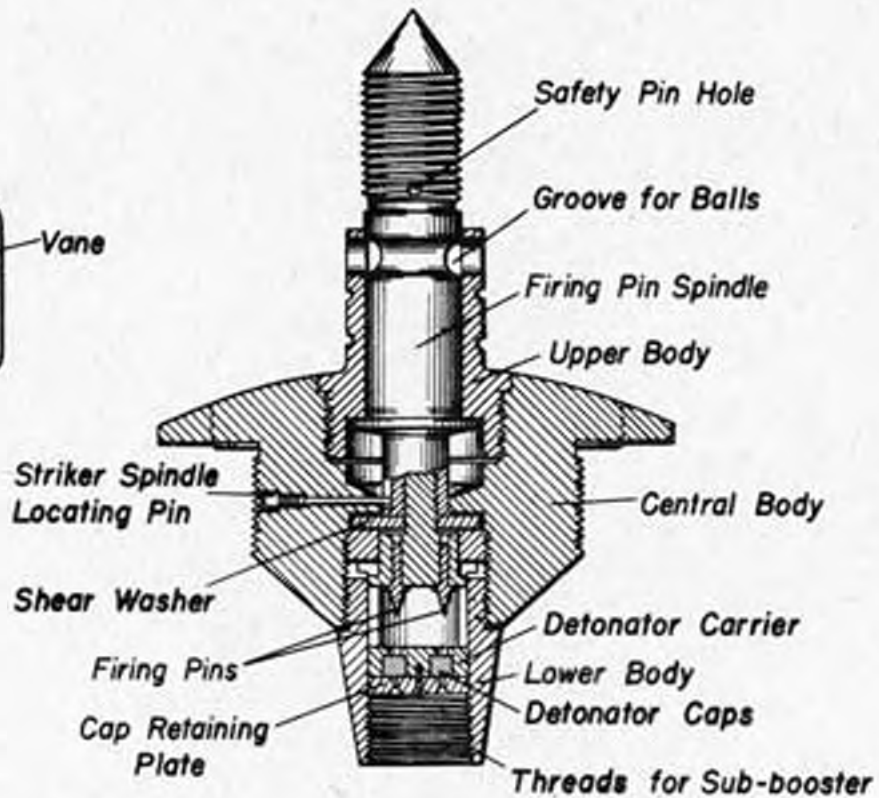

Fig. 3 - Type B Nose Fuze, Arming Vane  
Removed, Sectional View

ITALIAN MISCELLANEOUS

160/C. S. Depth Bomb

General

1. Anti-submarine bomb, fitted with nose and tail fuzes for impact of under-water firing.
2. Italian designation, "Bomba 160 C. S."

Description

1. Case

Shape	Cylindrical with rounded nose and tapered tail. Tail is fitted with four fins enclosed by a shroud ring 1573 in diameter.
Material	Steel
Diameter	1373
Length	
Overall	6978
Body	3672
Tail	2772
Charge	TNT (weight unknown)
Total weight in air	396 lb.

2. The bomb is fitted with nose and tail pockets to receive an impact, direct action nose fuze and an impact-armed, mechanically-fired tail fuze.

Type B Nose Fuze

Description

1. Instantaneous, impact fuze, mechanically armed.
2. The fuze is 778 long, 674 in maximum diameter and protrudes about 374 from the pocket. The span of the impeller is 674.
3. If the arming vane is missing from the nose, the fuze must be assumed to be armed.

Operation

1. Armed by the air vane which screws forward on its stem until it drops free, thereby releasing locking balls and freeing the firing pin. A blow of sufficient force on the firing pin spindle forces the firing pin down onto the detonator. The fuze is designed to fire upon land impact but not upon impact with water.

Rendering Safe Procedure

1. Tape the fuze vane securely to the fuze body. If the vane is not present, secure the firing pin spindle so as to prevent any movement.
2. Unscrew the fuze from the pocket.
3. Unscrew the sub-booster from the lower fuze body.
4. Dispose of all explosive elements without further disassembly.

Tail Fuze

Description

1. Mechanical fuze, armed by inertia on impact, fired by vane rotation.
2. The fuze is 3376 long, protrudes 5 1/4" from the pocket, and is fitted with a three-bladed arming vane. A cap, fitted over the hub of the arming vane, contains a setting disc with graduations from 0-90 (meters). A metal pressure plate, held prior to impact by a safety pin, washer and shear wire, fits flush against the vane cap.
3. If the fuze is armed, the small pressure plate on the vane cap will not be present.

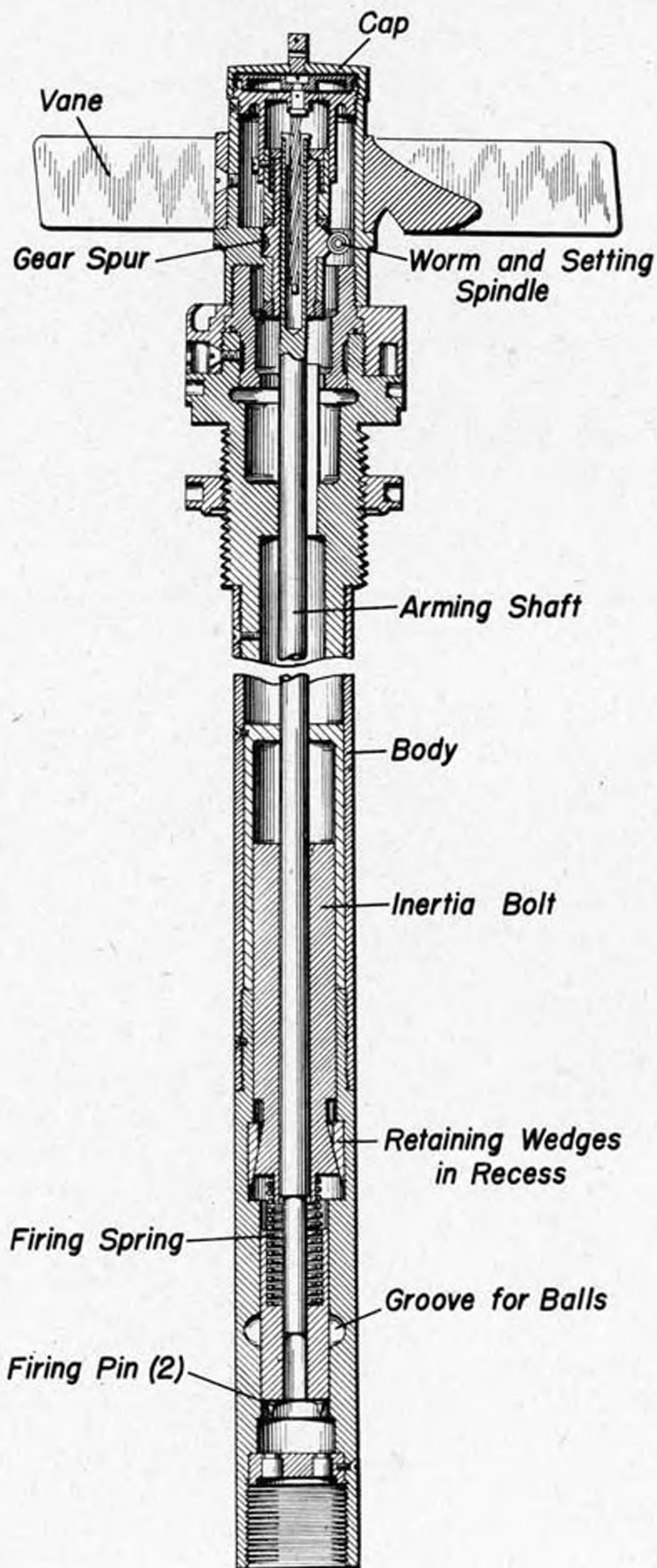

Fig. 4 - 160/C.S. Depth Bomb, Tail Fuze, Armed Position, Sectional View

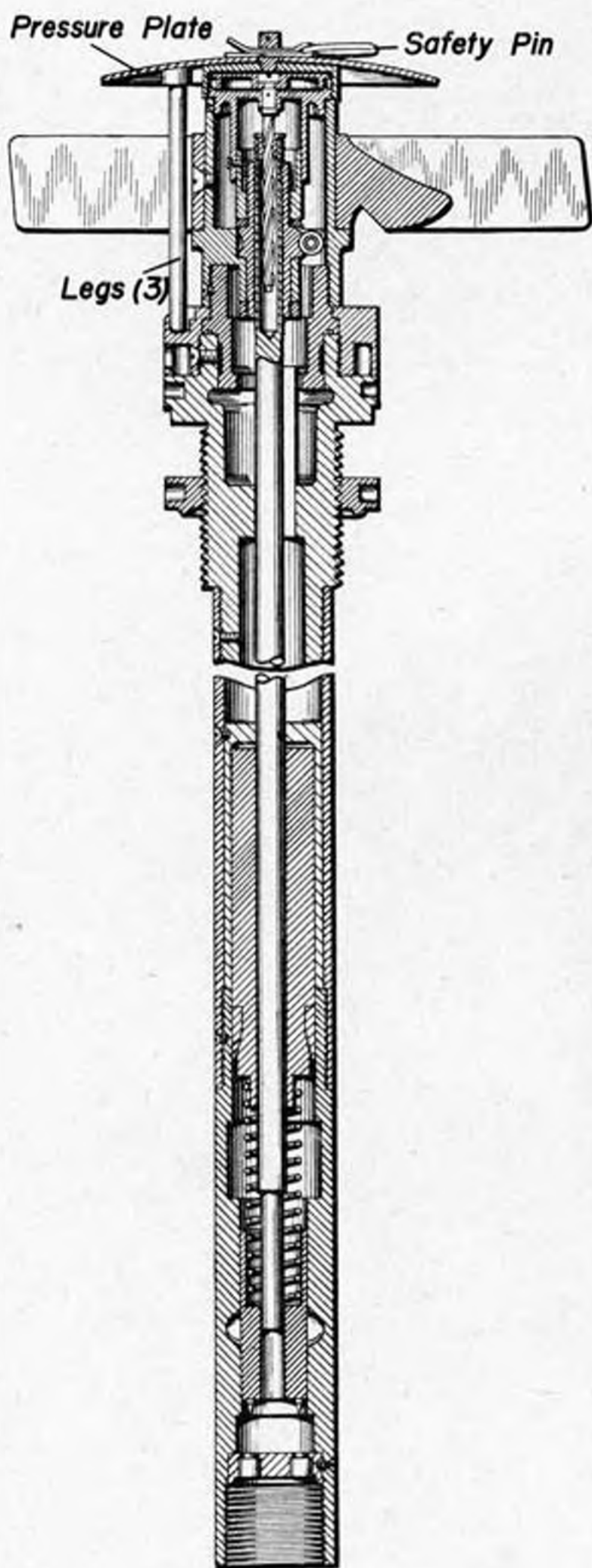

Fig. 5 - 160/C.S. Depth Bomb, Tail Fuze, Unarmed Position, Sectional View

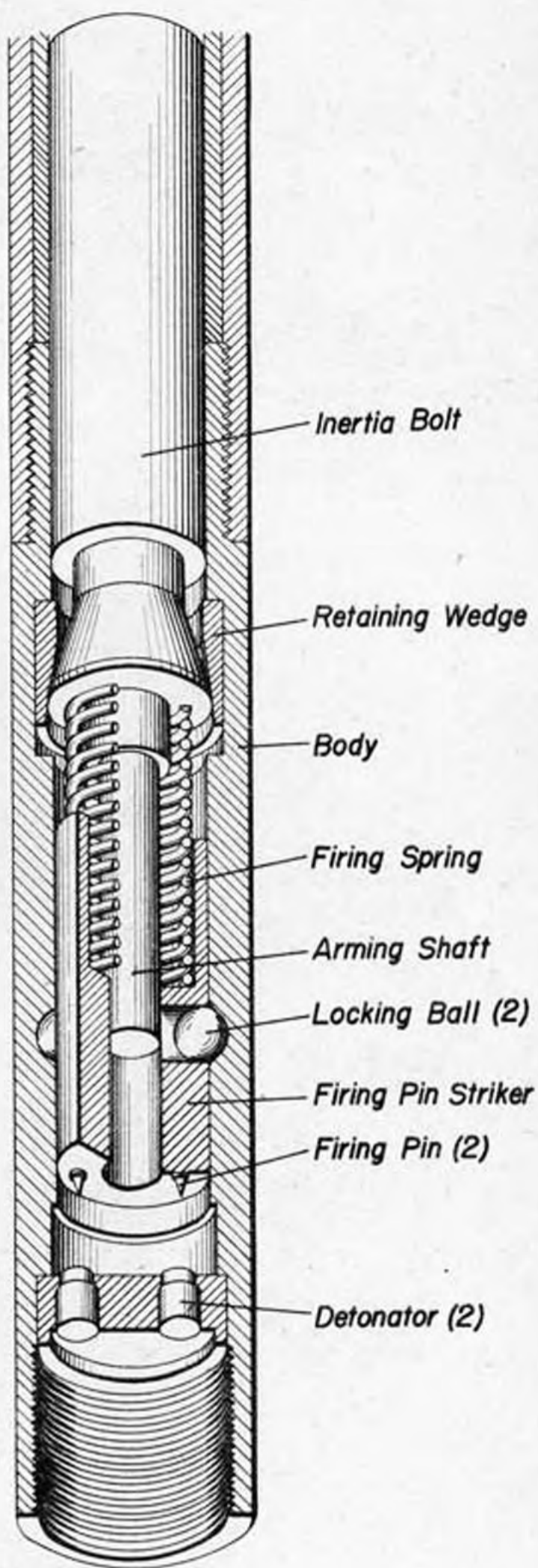

Fig. 5a - 160/C.S. Depth Bomb, Tail Fuze, Perspective View

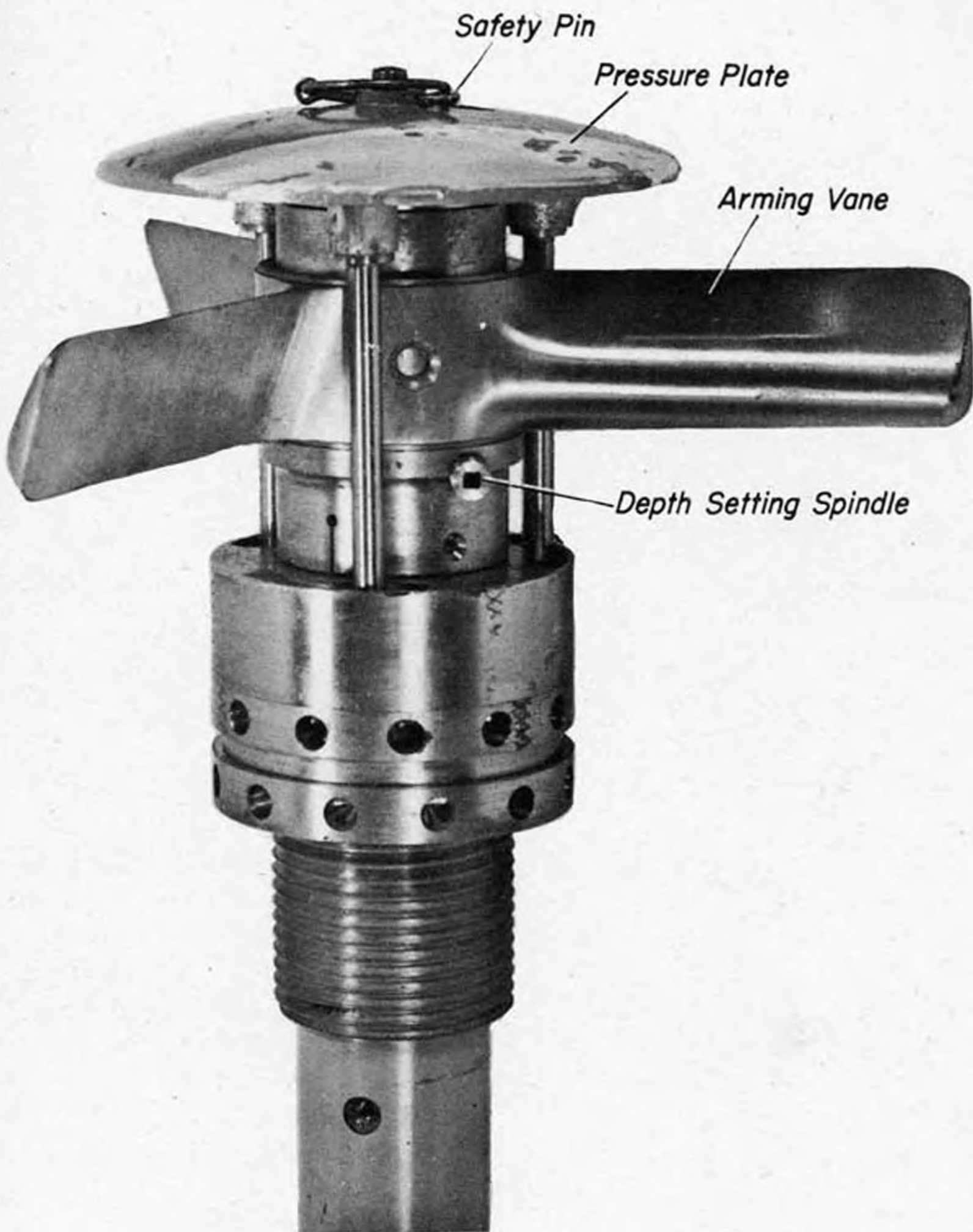

Fig. 6 - I60/C.S. Depth Bomb, Tail Fuze

(Tail Fuze, Cont'd.)

Operation

1. The depth setting is made manually. Inertia upon impact with water moves an inertia bolt downward, thereby compressing the firing pin spring. As the bomb sinks, water travel rotates the vane, retracting an arming spindle until, at the set depth, two lock balls are freed to move into a recess, releasing the spring-loaded firing pin to impinge on the detonator.

Rendering Safe Procedure

1. Tape the fuze vane securely to the fuze body.
2. Unscrew the fuze from the pocket.
3. Unscrew the sub-booster from the lower fuze body.
4. Remove the set screw at the lower end of the fuze body. This screw secures the detonator carrier.
5. Dispose of all explosive elements.

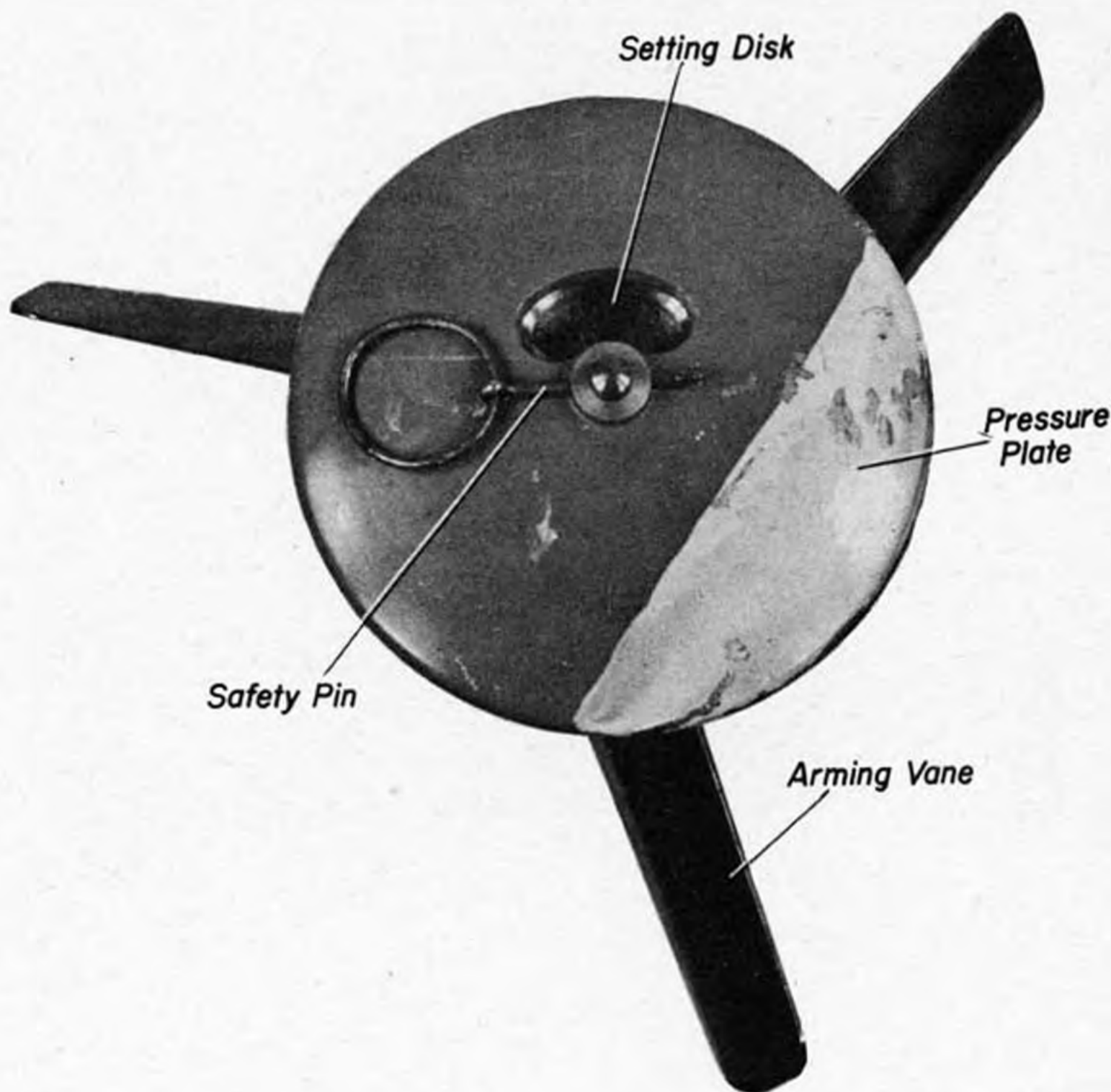

Fig. 7 - I60/C.S. Depth Bomb, Tail Fuze, End View Showing Pressure Plate

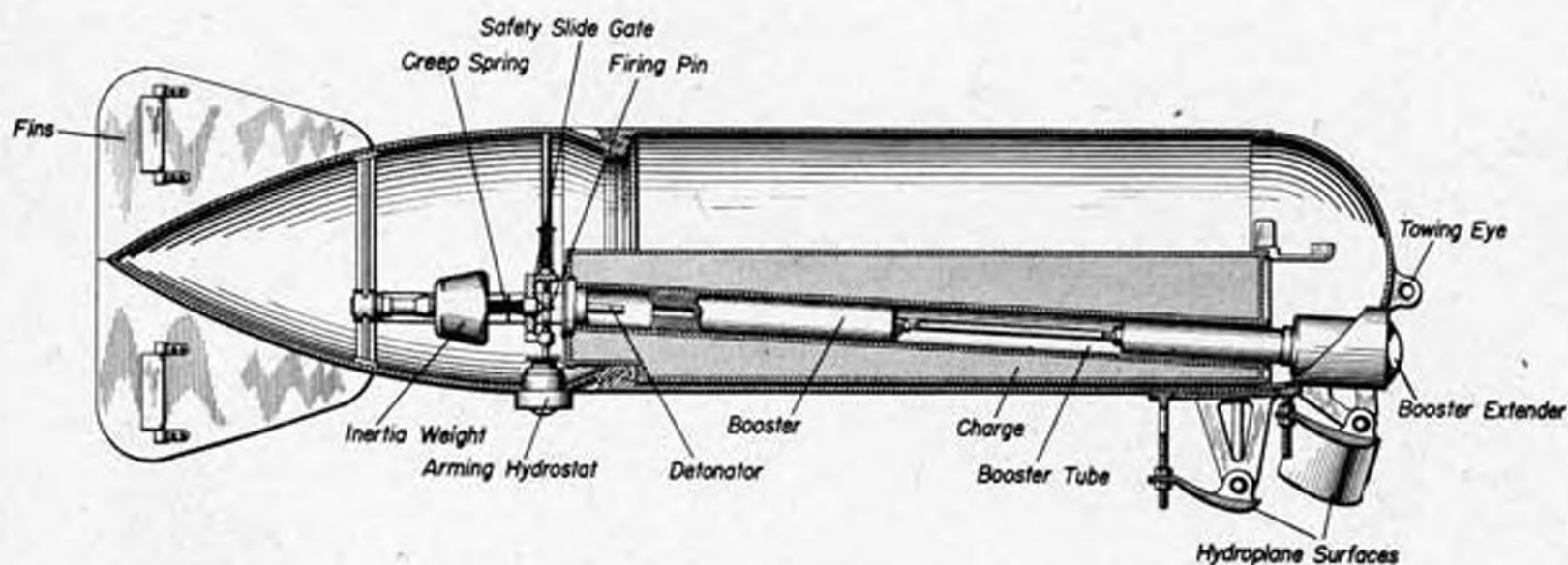

Fig. 8 - Explosive Paravane, Sectional View  
 ("Torpedine da Rimorchio T.R. 30/1916 I.A.")

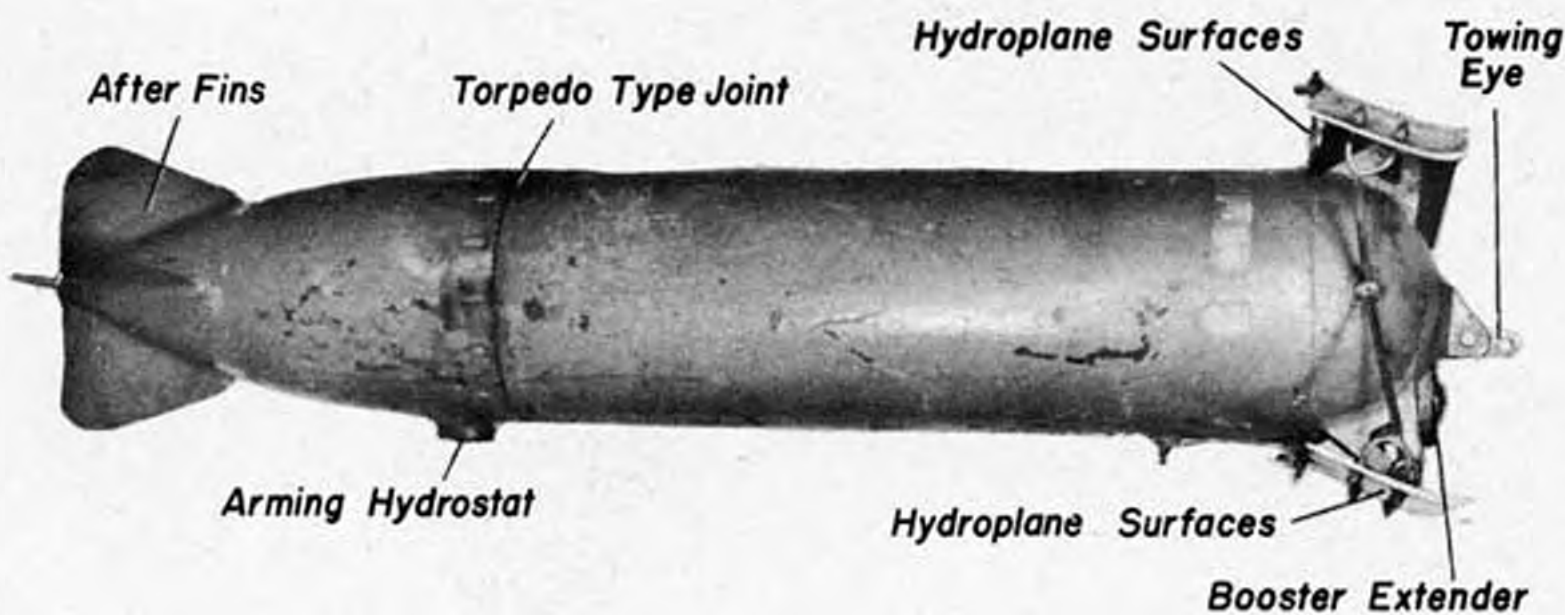

Fig. 9 - Explosive Paravane  
 ("Torpedine da Rimorchio T.R. 30/1917 I.A.")

Explosive ParavaneGeneral

1. Towed, inertia-fired, anti-submarine weapon, streamed from patrol craft.
2. Italian designation, "Torpedine da Rimorchio T. R. 30/1917 I. A."
3. Designed to be streamed between 50 and 120 ft. below the surface at speeds from 4-20 knots at a maximum distance of 360 ft. from the towing vessel.

Description

## 1. Case

Shape	Cylindrical with rounded nose and faired tail. Fitted with two hydroplane surfaces forward, and horizontal and vertical fins aft.
Color	Gray
Material	Steel
Diameter	11"
Length	6'5"
Charge	66 lb. cast TNT
Total weight in air	170 lb. approx.

## 2. External fittings

Booster extender	3 1/2" diam., on nose, secured by keep ring.
Arming hydrostat	2 1/2" diam., on lower surface of tail.
Towing eye	In center of nose.

Operation

1. When the paravane is launched, water travel causes it to submerge due to the hydroplane surfaces forward. The arming hydrostat unlocks the firing mechanism at a depth of 20 ft. and the booster extender houses the booster over the detonator at a depth between 20 and 30 ft. The paravane is now armed.
2. The paravane fires upon striking an object with sufficient force to cause an inertia weight to overcome a creep spring and force a firing pin into a detonator cap.
3. The booster extender and arming hydrostat are designed to withdraw the booster from the detonator and lock the firing device, respectively, if the paravane rises to a depth less than 20 ft.

Precautions

1. Do not move or jar the paravane except from a safe distance.

Rendering Safe Procedure

1. Remove the keep ring and booster extender. The booster is attached thereto.
2. Remove the detonator from the tail (exact method of assembly unknown).
3. Dispose of detonator, booster and charge.

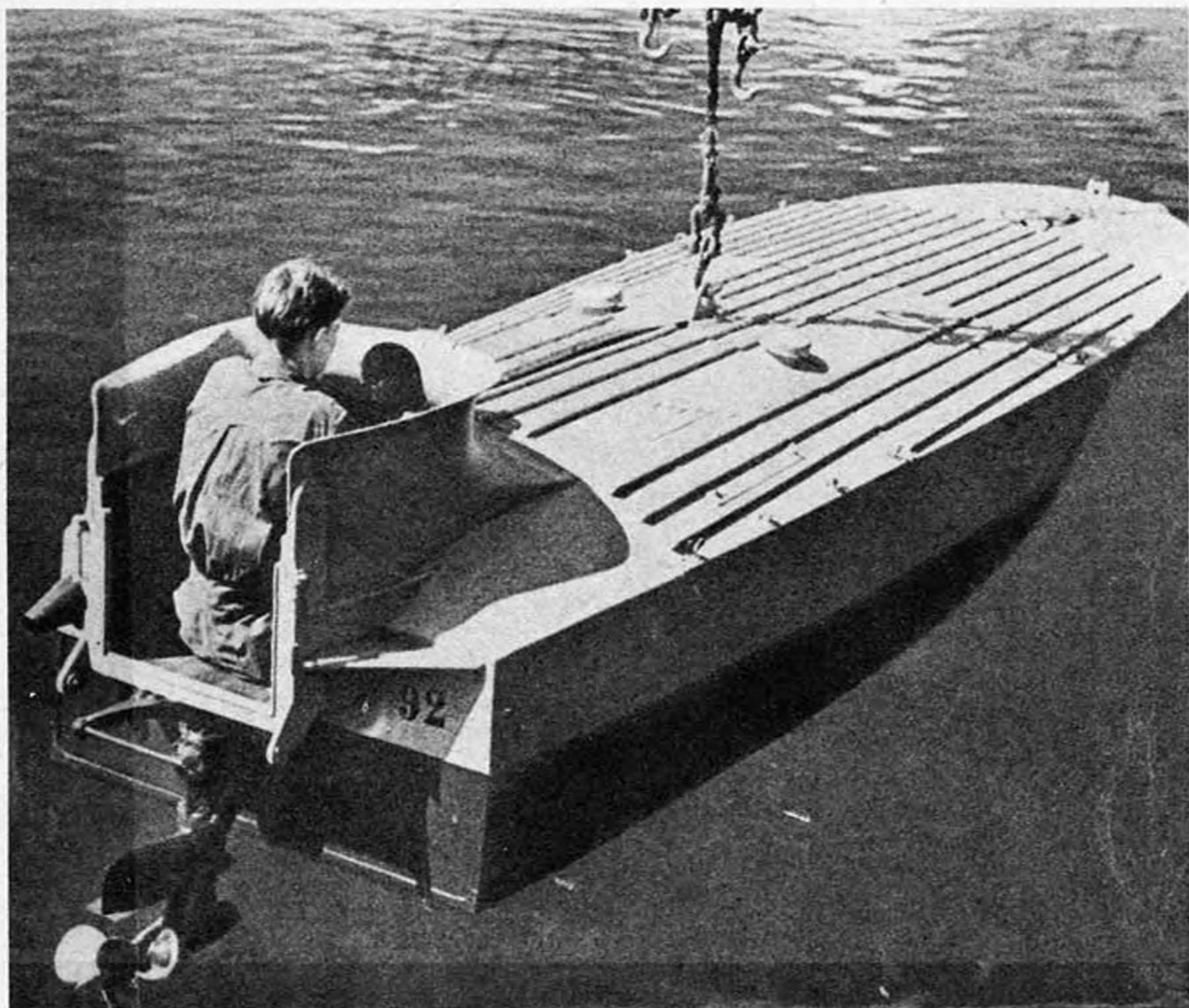

Fig. 10 - Explosive Motorboat

Explosive MotorboatGeneral

1. The explosive motorboat (Italian designation, "Motoscafo Turismo") is a light, wooden-hulled craft carrying a large explosive charge which may be fired either hydrostatically, by direct action on impact, or by a self-destroying delay fuze. The boat is powered by a gasoline engine and is piloted by a single operator who goes over the side having once set the boat on a collision course relative to its intended target. It was designed primarily as a weapon against merchant shipping although its sizable charge makes it effective against all but the largest and most heavily-armored capital ships.

Description1. Hull

- (a) The hull of the boat is rather similar to that of a commercial-type speedboat. Its bottom is V-shaped with a cutwater which extends aft to the beam, the remainder of the bottom being flat. The hull is constructed of five-ply, 5/8", mahogany-veneered plywood and is strengthened by 1" x 1" transverse ribbing at one-foot intervals. Significant figures and dimensions are as follows:

Length overall (including cockpit)	19' 8 1/2"
Length of hull proper	18'
Length at waterline	17' 9"
Beam	5'3"
Maximum height	3'2"
Cockpit freeboard	2'11"

- (b) The decking, which encloses the entire boat except for the pilot's compartment, may logically be divided into five main parts, reading aft from forward, as follows:
  - (1) A fixed section, 3' 10" long, which forms the forecastle. A fender bar framework of welded steel pipe is fitted over the forecastle and overlaps the deck so that if the boat makes contact with a target, the framework tends to move aft. A bow fender bar attached to the framework may be swung down in front of the cutwater to increase the striking surface. The section contains a hole near the center of its after edge, through which a small shaft protrudes. The shaft is attached at its upper and lower ends, respectively, to the framework and to the firing switch on the underside of the deck.
  - (2) A removable section, 4' long, which covers the charge compartment and is secured by 12 drop bolts. This section contains an air vent on its port side.
  - (3) A fixed section, 3' long, which covers an empty compartment abaft the charge compartment and the forward end of the engine room.
  - (4) A removable section, 4' long, which covers the greater part of the engine room and is secured by 12 dogs. This section contains hatches to port and to starboard.
  - (5) A fixed section, 5 1/2' long, which extends to the stern of the boat and contains the pilot's cockpit.
- (c) The pilot's cockpit is sunk into the after end of the engine room and is about 30" square. The seat protrudes over the stern and contains a back rest consisting of two hinged, plywood floats secured in the vertical position. The panel board contains the customary **gauges** and steering apparatus and, in addition, a button switch which controls a switch in the circuit to the main charge detonator controlled by the impact firing device. A toggle on the port side of the cockpit is used to release the floats and also to arm the various firing devices.

2. Engine

- (a) The boat is powered by a six-cylinder Alfa-Romeo gasoline engine of about 200 h.p. Transmission is through a clutch controlled by a lever in the pilot's cockpit. Two counter-rotating propellers are fitted. The boat's maximum speed is 30 knots, its cruising speed, about 20 knots, and it is estimated to have a range of about 120 miles at cruising speed.

3. Explosive Charges(a) Main charge

- (1) This consists of 560 lb. of TNT cast in a cylindrical container

(Explosive Motorboat, Cont'd.)

34" long and 19 1/2" in diameter. It is mounted athwartships in two wooden cradles in the charge compartment and is secured by two metal bands. A central tube, 2 3/4" in diameter, runs the full length of the container and contains a brass booster can. Two filling holes, each 3 3/4" in diameter, are fitted to one end of the container. A hydrostatic pistol fits into the port end of the central tube and the starboard end contains the inner end of a casting which consists of (1) a delay fuze and (2) an electric detonator and leads.

## (a) Scuttling charge

- (1) This consists of a primacord charge fitted to the forward edge of the after bulkhead of the charge compartment and a metal tube of TNT located forward of the third rib under the fore-castle. The primacord charge is designed to sever the charge compartment and fore-castle from the rest of the boat whereas the TNT tube is designed to sever the fore-castle and bow from the charge compartment. Six electric detonators are fitted to the charges which are designed to be fired simultaneously.

4. Firing Devices

(a) The boat incorporates three main types of firing devices as follows:

- (1) A simple hydrostatic pistol consisting essentially of a housing, a hydrostatic diaphragm and spindle, and a spring-loaded firing pin assembly restrained by two lock balls. This pistol is armed by the toggle lever in the pilot's cockpit and fits into the port end of the charge container central tube.
- (2) An impact-direct action firing mechanism which operates upon displacement of the fender-bar arrangement on the fore-castle. The fenders are connected mechanically to a normally-open switch which is in the circuits of the respective electric detonators fitted to the main charge and scuttling charges.
- (3) A delay action firing mechanism (self-destroying feature) which consists essentially of a black powder delay fuse, wound around an aluminum housing, and a detonator. A spring-loaded firing pin assembly is contained within the housing and is restrained by a safety pin which in turn is controlled by the toggle bar in the pilot's cockpit. Operation of this mechanism fires the main charge.

Operation

1. The pilot sets the boat's course and speed so that a collision with the desired target may be expected. The type of target ordinarily determines the type of firing that is employed. Delay action hydrostatic firing is ordinarily used against stationary targets whereas direct action impact firing is used against moving targets. Having set the target's course and speed, the pilot then determines the type of firing to be employed. If direct action impact firing is to be employed, the pilot closes the button switch on the dashboard, putting the electric detonator of the impact firing device in the battery circuit. If this is not done, delay action hydrostatic firing is obtained. Having determined the type of firing, the pilot pulls the toggle on the port side of the cockpit, resulting in the following:
  - (a) The hinged float is released and dropped in the water. The pilot goes over the side at this point and climbs on the float to protect himself from the explosion.
  - (b) Strain is taken on a heavy bowden wire which is attached to the toggle and which leads to a transmission box on the after port side of the charge compartment where it controls four other wires. Strain is put on these four wires, resulting in the following:
    - (1) A safety pin is withdrawn from a spring-loaded switch on the other side of the charge compartment, allowing a plunger to move forward and close a break in the circuits of the respective electric detonators fitted to the main charge and scuttling charges.
    - (2) A safety pin is withdrawn from the hydrostatic pistol, arming the pistol.
    - (3) A spring-loaded firing pin is released, igniting the delay fuze in the self-destroying feature.
    - (4) Two plungers are withdrawn from the impact firing switch under the fore-castle, arming the switch.

## (Explosive Motorboat, Cont'd.)

2. When the boat contacts a target, it may fire in one of two ways as follows:
  - (a) If set for impact firing, contact with the target moves the fender framework on the forecastle aft, closing the firing switch and completing the circuit from the battery through the main charge detonator controlled by the impact firing device and through the scuttling charge detonators.
  - (b) If set for hydrostatic firing, contact with the target moves the fender framework aft, closing the firing circuit and completing the circuit from the battery through the scuttling charge detonators. The portion of the boat forward of the after bulkhead of the charge compartment is then sheared by the primacord charge, and the TNT charge under the forecastle demolishes the bow. The charge compartment then sinks. When the hydrostatic pistol reaches a depth of 18 ft., the hydrostatic diaphragm moves inward, releasing the lock balls and allowing the spring-loaded firing pin to impinge on the detonator and fire the main charge.
3. If the boat makes no firing contact within six minutes after the toggle is pulled, the delay fuze of the self-destroying feature burns through its entire length and fires its detonator and the main charge.

Precautions

1. Stand clear of the forward end of the boat, being especially careful not to contact the fenders. Always board the boat over the side or stern.
2. Except in extreme emergency, do not approach the boat unless it can be positively ascertained that the self-destroying delay fuse has not been ignited. If it should be necessary to board the boat without knowing the condition of the delay fuse, wait a period of at least 12 hours before boarding if the military situation permits.

Rendering Safe Procedure

1. Remove the portion of the deck covering the motor compartment and disconnect all battery leads.
2. Remove the portion of the deck covering the charge compartment and insert a safety pin in the hydrostatic pistol on port side of the charge.
3. Disconnect the mechanical lead to the delay fuse in the starboard end of the central tube of the charge container, using extreme care not to exert any tension on the lead. Such tension will ignite the delay fuse if it has not already started.
4. Loosen the metal bands and remove the charge container.
5. Unbolt the casting containing the delay fuse and detonators from the starboard end of the central tube.
6. Cut and tape the electrical leads running from the main junction box located on the upper frame of the after bulkhead of the charge compartment. This disconnects the scuttling charges.
7. Remove the frame containing the primacord scuttling charge.
8. Remove the TNT scuttling charge from under the forecastle.
9. Dispose of all explosive elements.