

Share this copy!

VOL. II NO. 1

SEPTEMBER 1943

INTELLIGENCE BULLETIN

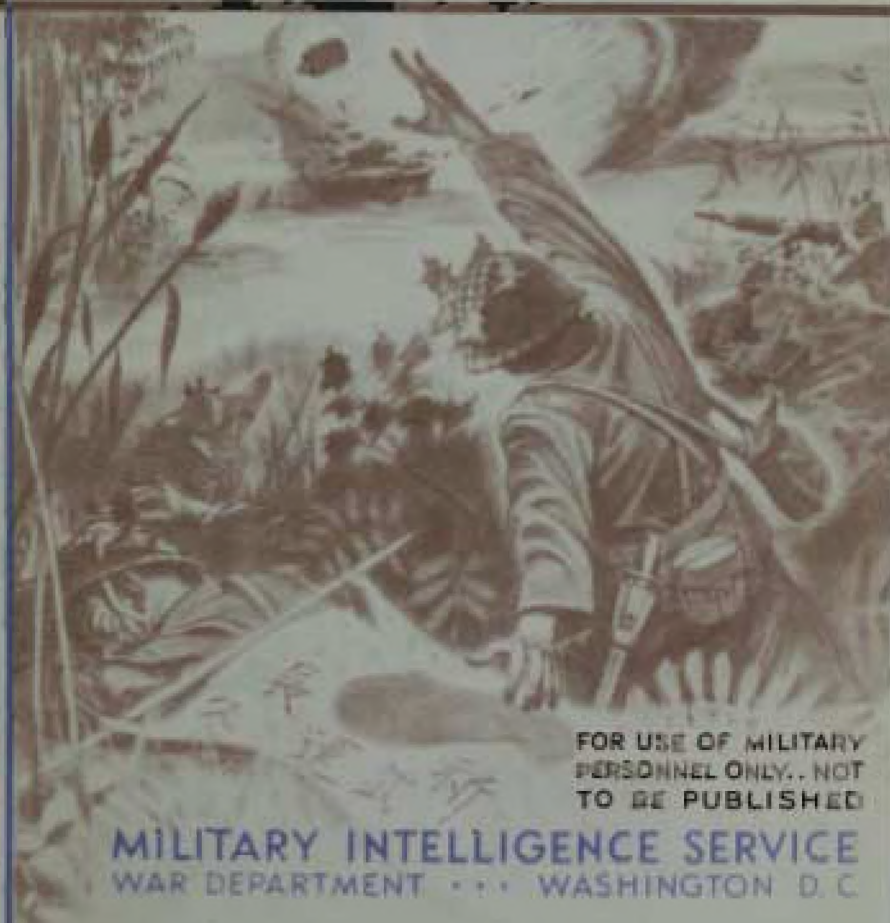

FOR USE OF MILITARY
PERSONNEL ONLY. . NOT
TO BE PUBLISHED

MILITARY INTELLIGENCE SERVICE
WAR DEPARTMENT . . . WASHINGTON, D. C.

"Inspired by the determination for victory, convinced of our complete superiority over our enemies, especially over the Americans, and full of confidence in our commanders, we shall attack and defeat the enemy everywhere."

—German regimental order of 12 February 1943.

Military Intelligence Service
WAR DEPARTMENT
Washington, September 1943

Intelligence Bulletin
Vol. II, No. 1
MIS 461

NOTICE

The *Intelligence Bulletin* is designed primarily for the use of junior officers and enlisted men. It is a vehicle for the dissemination to them of the latest information received from Military Intelligence sources. In order to secure the widest possible use of this bulletin, its contents are not highly classified. It is for the exclusive use of military personnel, however, and no part of it may be published without the consent of the Military Intelligence Service, except in the case of task forces, divisions, and higher echelons. Commanders of these organizations are authorized to reproduce any item in the bulletin, provided they maintain the classification of the information and give its source.

It is recommended that the contents of this bulletin be utilized whenever practicable as a basis for informal talks and discussions with troops.

Readers are invited to comment on the use that they are making of the *Intelligence Bulletin* and to forward suggestions for future issues. Such correspondence may be addressed directly to the Dissemination Unit, Military Intelligence Service, War Department, Washington, D. C. Requests for additional copies should be forwarded through channels for approval.

I

TABLE OF CONTENTS

PART ONE: JAPAN

	Page
SECTION I. LAND MINES, GRENADES, AND BOOBY TRAPS.....	1
1. General.....	1
2. Land Mines.....	2
a. <i>Antivehicle</i>	2
b. <i>Antipersonnel (Dutch)</i>	5
c. <i>Armor-piercing (magnetized)</i>	6
3. Fragmentation Grenades.....	9
a. <i>Type 91</i>	9
b. <i>Type 97</i>	12
c. <i>Stick Type</i>	13
4. Electric Booby Traps.....	15
5. Bangalore Torpedo.....	15
II. NEW JAPANESE WEAPONS FOR INFANTRY SQUAD.....	16
1. General.....	16
2. Model 99 Rifle.....	17
3. Model 99 Light Machine Gun.....	18
a. <i>General</i>	18
b. <i>Distinguishing Features</i>	18
c. <i>Comment</i>	20
III. TYPE 98 AA/AT GUN.....	21
1. General.....	21
2. Table of Characteristics.....	21
3. Description of Component Parts.....	21
a. <i>Tube</i>	21
b. <i>Magazine</i>	23
c. <i>Carriage</i>	23
d. <i>Recoil System</i>	24
e. <i>Sights</i>	24
4. Notes on Operation.....	25
a. <i>Getting into Position</i>	25
b. <i>Firing</i>	26
IV. JAPANESE COMMENT ON U. S. RESISTANCE IN PHILIPPINES.....	27
1. Introduction.....	27

PART ONE: JAPAN—Continued

SECTION IV. JAPANESE COMMENT ON U. S. RESISTANCE IN PHILIPPINES—
Continued.

	Page
2. The Document.....	27
a. <i>Fighting Spirit</i>	27
b. <i>Command and Control</i>	28
— c. <i>Regarding Tanks</i>	28
d. <i>Regarding Weapons and Vehicles</i>	29
e. <i>Training</i>	29
V. COMMENTS ON JAPANESE BY BRITISH SOLDIERS.....	30
1. Introduction.....	30
2. The Comments.....	30
a. <i>Movement</i>	30
b. <i>Patrol Tactics</i>	31
c. <i>Deception</i>	31
d. <i>Use of Artillery</i>	31
e. <i>Use of Mortars</i>	32
f. <i>Night Attacks</i>	33
g. <i>Snipers</i>	33
h. <i>Communications</i>	33

PART TWO: GERMANY

SECTION I. GERMAN RULES FOR USE OF CONTAMINATION BAT-
TERIES.....

1. Introduction.....	34
2. Terrain Contamination.....	34
II. SOME BASIC PRINCIPLES OF COASTAL DEFENSE.....	37
1. Organization of Strong Points.....	37
2. Organization of Defense Areas.....	38
3. Use of Artillery.....	38
4. Conduct of Battle.....	39
III. BARBED-WIRE OBSTACLES.....	40
1. General.....	40
2. Specific Types.....	42
a. <i>Knife Rests</i>	42
b. <i>Apron Fences</i>	42
c. <i>Vertical Fences</i>	43
d. <i>Concertina Fences</i>	43
e. <i>Trip Fences</i>	43
f. <i>Alarm Wires</i>	43
g. <i>Electrified Wire</i>	44
h. <i>Combined Fences</i>	44

TABLE OF CONTENTS

v

PART TWO: GERMANY—Continued

SECTION III. BARBED-WIRE OBSTACLES—Continued.	Page
3. Standard Technique.....	44
a. <i>Obstacle in Depth</i>	45
b. <i>Wire-netting Fences</i>	46
c. <i>Trip-wire Obstacles</i>	46
IV. TYPES OF CONCRETE ANTITANK OBSTACLES.....	47
1. Walls.....	47
a. <i>General</i>	47
b. <i>Continuous Walls</i>	48
c. <i>V-shaped Walls</i>	48
d. <i>Walls with Gaps</i>	48
2. Other Concrete Obstacles.....	49
a. <i>Dragons' Teeth</i>	49
b. <i>Plain Blocks</i>	50
3. Rails Embedded in Concrete.....	50
V. RECONNAISSANCE METHODS.....	51
1. Introduction.....	51
2. Analysis of German Reconnaissance.....	51
VI. FURTHER INFORMATION ABOUT GERMAN TANKS.....	55
1. Armor Arrangement.....	55
2. Submersible Tanks.....	55
VII. MISCELLANEOUS.....	62
1. Directive for Defense of Positions.....	62
a. <i>Introduction</i>	62
b. <i>The Directive</i>	62
2. Basic Infantry Tactics.....	64
a. <i>Approach March</i>	64
b. <i>Attack</i>	64
c. <i>Defense</i>	65
3. Tank Ruse to Deceive Artillery.....	66
4. Handling of Prisoners.....	67
5. "This Must Not Occur Again".....	68
6. Railroad Patrol Car (Armored).....	68
7. "We Cannot Lose".....	70
8. Rules for Laying Tellermines.....	71
9. Note on Captured Mines.....	71
10. Device for Stranded Flyers.....	72

PART THREE: UNITED NATIONS

SECTION I. LIVING IN THE JUNGLE.....	74
1. Introduction.....	74

PART THREE: UNITED NATIONS—Continued

SECTION I. LIVING IN THE JUNGLE—Continued.		Page
2.	Climate.....	75
3.	Insects.....	77
4.	Leeches.....	79
5.	Snakes.....	80
6.	Crocodiles.....	81
7.	Wild Animals.....	81
8.	Poisonous Vegetation.....	82
9.	Natives.....	83
10.	Equipment.....	84
11.	Water.....	86
12.	Food.....	86
13.	Shelter.....	89
14.	Making a Fire.....	89
15.	Pointers on Observation.....	90
16.	Movement.....	91
17.	Maintaining Direction.....	91
II. BRITISH USE OF TANKS IN JUNGLE WARFARE.....		93
1.	Introduction.....	93
2.	The Memorandum.....	93
	a. <i>The Approach</i>	93
	b. <i>Attack</i>	94
	c. <i>Defense</i>	95
	d. <i>Withdrawal</i>	96

LIST OF ILLUSTRATIONS

FIGURE 1.	Japanese Antivehicle Mine (Type 93).....	3
FIGURE 2.	Japanese Armor-piercing Mine (magnetized).....	7
FIGURE 3.	Japanese Hand Grenade (Type 97).....	10
FIGURE 4.	Japanese Stick Grenade.....	14
FIGURE 5.	Japanese Model 99 Light Machine Gun.....	19
FIGURE 6.	Japanese Model 98 AA/AT Gun (20 mm).....	22
FIGURE 7.	German Obstacle in Depth.....	45
FIGURE 8.	Wharves and Quays.....	49
FIGURE 9.	German Pz. Kw. 3.....	56
FIGURE 10.	German Pz. Kw. 4.....	57
FIGURE 11.	German Pz. Kw. 6.....	58
FIGURE 12.	German Railroad Patrol Car (armored).....	69
FIGURE 13.	German Device for Stranded Flyers.....	72

PART ONE: JAPAN

Section I. LAND MINES, GRENADES, AND BOOBY TRAPS

1. GENERAL

The Japanese, as compared with the Germans, have used land mines and booby traps on a small scale to date. This is largely due to the fact that the Japanese were on the offensive until our invasion of Guadalcanal—and even there the enemy held most of the island for several months afterwards and, almost to the end, maintained high hopes of annihilating us. As a rule, no enemy will lay mines and booby traps on a big scale if he expects to move over the area himself sometime in the immediate future. When the Japanese are forced to assume the defensive on a large scale, with little hope of advancing, they are expected to use mines and booby traps extensively. The use of such weapons would certainly be expected of an enemy who has been highly deceptive and treacherous in many other respects.

If our soldiers are alert and have a general idea of the appearance and function of mines and booby traps, they should not entertain any great fear of these weapons. As one Guadalcanal observer pointed out, we should never assume that an area recently occupied

by the enemy, or equipment therein, is safe until it is thoroughly checked. A death caused by an enemy booby trap is considered a needless and useless sacrifice. Enlarging his remarks about the Japanese, the observer said:

Whenever the enemy abandons an area which has been held against siege, or which has been in his possession for any length of time, he will usually attempt to lay traps for the forces occupying the area. These traps usually consist of simple improvised devices, such as antipersonnel mines placed under loose boards likely to be walked on, antivehicle or tank mines placed in the tracks of a narrow road, or devices fastened to doors or laid across narrow paths.

The purpose of such traps is twofold: (1) to cause front-line casualties, and (2) to slow the advance of the attacking forces.

At the present time, the Japanese are known to have three types of land mines and two types of grenades which can be used in such traps as those described above.

2. LAND MINES

a. Antivehicle

The Japanese antivehicle mine, officially known as Type 93, is commonly called "the tape-measure mine" because it resembles an ordinary rolled-up tape measure see fig. 1). The weapon weighs 3 pounds, and has a diameter of $6\frac{3}{4}$ inches and a thickness of $1\frac{3}{4}$ inches. It is filled with 2 pounds of a picric acid compound. The mine container, which consists of two light-metal sections, is painted either yellow

or olive drab. In the center of the top is a brass dome or plug, which screws into the mine and covers the fuze. The plug, $1\frac{1}{2}$ inches in diameter, has a $\frac{3}{8}$ -inch red band painted around it. On opposite sides of the circular weapon are two rings, spaced 2 inches apart, which often have small loops of rope secured to them. The rope can be used in carrying the mine, in hanging it up when it is not in use, or in dragging it across the path of a tank.

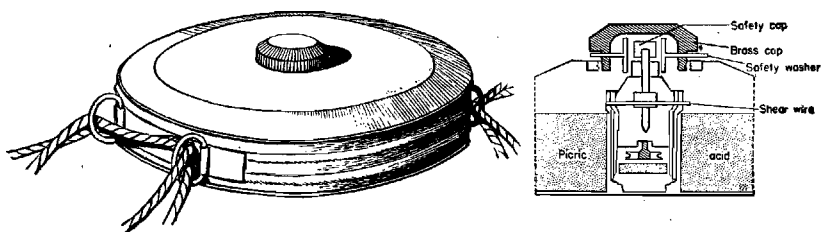

Figure 1.—Japanese Antivehicle Mine (Type 93)

The mine is exploded by pressure applied on the brass plug. Normally more than 200 pounds of pressure is required to activate the weapon, but no chances should be taken. Actually, a shear wire—which holds the firing pin in a cocked position—determines the pressure necessary to explode the mine. The wire may vary in strength according to the tactical use of the weapon. Some reports indicate the use of shear wires which require a pressure of only 70 pounds to break. Pressure applied to the brass plug first crushes the top cover; the brass plug then contacts the top of the firing pin, thereby putting stress on the shear wire and causing it to break. When it breaks, the mine explodes.

The safety cap, which is small, screws onto the upper end of the firing pin. When in position, this cap prevents depression of the firing pin and explosion of the mine. An additional safety device in the form of a brass collar is attached to a safety washer. This collar and washer fit around the firing pin and safety cap.

Usually these mines are laid in patterns of diagonal rows, with the mines about 30 inches apart. The plug of each mine usually is at ground level. If the presence of a minefield is suspected, the ground should be probed with bayonets. Test the ground every 5 inches keeping the bayonet as nearly horizontal as possible. Soon the pattern in which the mines are laid will become apparent, and your work will be greatly speeded.

To neutralize the Type 93 mine, first examine the area around the weapon for booby traps. Then, without moving the mine or exerting any pressure on the cover, unscrew and remove the brass plug. Without any downward pressure, screw the safety cap tightly into the top of the plunger. Place the safety collar and washer over the safety cap, and screw on the brass plug.

To disarm the mine, unscrew the brass plug without exerting any downward pressure. Then unscrew and remove the whole igniter assembly from the base of the mine.

The mines should be placed clear of the road or area. Do not throw them down or pile one upon the

other; under no circumstances should you strike the plug or allow it to receive any pressure. After a careful inspection for booby-trapping devices, the mines can safely be picked up by the rings.

b. Antipersonnel (Dutch)

The Japanese captured a quantity of Dutch anti-personnel mines in Java, and may have used a number of them on Guadalcanal.

The Dutch mine, painted an olive drab, is $8\frac{1}{2}$ inches in diameter and $3\frac{1}{2}$ inches thick. It has a dome-shaped cover, which is held off the striker by a light spring. The cover is fastened to the mine by four screws.

Fifty pounds of pressure on the cover of this mine, from any direction, will detonate it. The mines are usually laid in narrow places, on trails, on beaches, or at the entrance to a bivouac area.

They can easily be hidden under a palm frond (leaf) or a light plank. Normally the Japanese place them on top of the ground, but you can expect to find them partly or wholly buried under loose sand or earth. Small patches of disturbed ground may conceal these mines. It would be suicidal to use more than light pressure in probing for them.

To remove these mines, carefully scrape away the loose dirt and pick up the individual mine by the cover—never by the bottom. Lay it gently on the ground, and, with your knife, remove the four screws which fasten the cover. Remove the cover and then

unscrew the igniter. After laying the safe mine to one side, mark it "Safe" before proceeding, so that others will not waste time repeating your work.

c. Armor-piercing (magnetized)

The Japanese armor-piercing mine (magnetized) contains eight separate sections of cast TNT, which are wrapped in wax paper and held together in a khaki-colored canvas bag (see fig. 2). It is circular in shape, with two flat surfaces. Four equally spaced permanent magnets are attached by khaki webbing to the outer edge of the body. The mine is carried in a stiff canvas pouch which attaches to the soldier's belt. Fitted to the inside of the pouch is a cylindrical metal container for holding the igniter, which must be inserted into the mine prior to using. A wooden plug is carried in the igniter cavity of the mine when the latter is carried in the pouch. The plug is removed to permit fitting of the igniter, which is secured to the mine container by an igniter-retaining nipple and held by a threaded brass collar. The complete mine with igniter weighs 2 pounds 11 ounces.

The mine is detonated by a sensitive delayed-action, percussion-type igniter, which is shown in figure 2. The protruding end of the igniter consists of a firing pin, which is attached to the igniter body by a set screw through the firing-pin set-screw slot. The firing-pin assembly is spring-loaded by the firing-pin spring, and is held in the loaded position by four steel balls, which fit into the circular groove in the firing-pin assembly and the holes provided in the igniter body. A

firing-pin spring locking plug limits the spring at the upper end of the igniter body. The steel balls are held in place by the firing pin, which has a continually increasing internal diameter from the open end; and

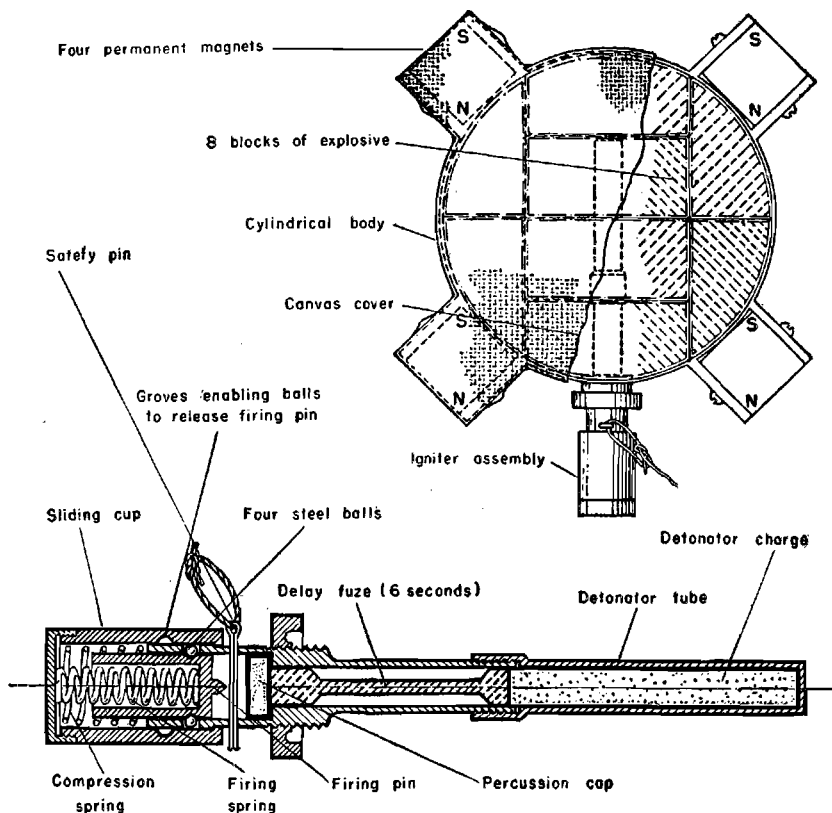

Figure 2.—Japanese Armor-piercing Mine (magnetized)

as the firing pin is depressed against the firing-pin spring, the steel balls are forced from their position by pressure of the firing-pin spring on the firing-pin assembly, thus allowing the firing pin to go forward.

The firing pin is prevented from being depressed by a safety pin positioned in the safety-pin hole in the igniter body. A length of cord is attached to the firing pin for withdrawing purposes. The primer and delay element screws into the igniter body. The detonator element screws onto the delay element. The primer is of the percussion type, and the delay element is of the pressed black-powder type, with a burning time of approximately 10 to 12 seconds. The igniter body is provided with a fusible plug to allow escape of the gases from the delay element.

This type of mine is intended for direct use against armored vehicles, shields on gun mounts, doors of pill-boxes, and so forth. The mine is placed in contact with the iron or steel object and adheres to it by action of the magnets. The safety pin is withdrawn, and the firing pin is depressed, actuating the igniter and exploding the mine in approximately 4 to 5 seconds. During this time the attacker must make his escape.

While it is reported that the mine may be thrown by hand, it is considered, from the shape and design of the mine and igniter, that it is not suitable for this purpose and must be placed by hand in direct contact with any metallic part of the objective. Provided that a suitable type of igniter is used, the mine may be set up as a booby trap if placed under a loose board or arranged in other ways, as suggested for the hand grenades. The igniter designed for this mine is not particularly suitable for booby trapping. Other types of igniters could be used with this mine for booby-trapping purposes.

3. FRAGMENTATION GRENADES

The Japanese are known to have at least four types of fragmentation grenades, but all are constructed along the same general lines. They differ slightly in dimensions, and two of them have added attachments. It would be possible to use any of these grenades in devising booby traps.

a. Type 91

This is a hand grenade, and is believed to be a revised version of the "10-year type" grenade. The latter type, which is not being widely used, will not be discussed here since it is very similar to Type 91, the most common of all types, and the one most likely to be used in devising booby traps.

The Type 91 grenade has a cylindrical body. Its outer surface has both horizontal and vertical grooves, which form rectangular notches (see fig. 3). These grooves are designed to cause the grenade to break into small pieces at the time of detonation. Actually, however, the grenade does not fragment as much as intended. In some cases, according to observers, the weapon has been known to break into only two pieces. U. S. observers on Attu reported that it was not as effective as our fragmentation grenade.

The fuze, made of brass, screws into the top of the grenade, the base of which is solid. The fuze has a cap on the upper end. This cap holds a spring-loaded striker in the body of the fuze. Holes are drilled through both the cap and fuze—near their ends—for the insertion of a safety pin.

JAPANESE HAND GRENADE WITH PROPELLANT ATTACHMENT

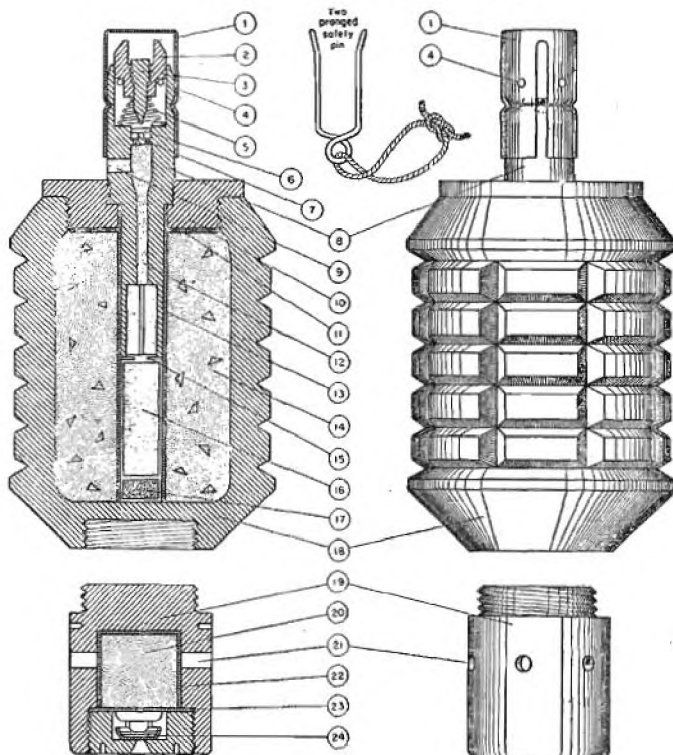

LEGEND

- | | |
|--|---|
| <ol style="list-style-type: none"> 1. Firing pin safety cover 2. Firing pin holder, [has two shoulders under which the two prongs of safety pin fit]. 3. Firing pin 4. Holes for insertion of safety pin. 5. Creep spring 6. Percussion cap 7. Two flash holes 8. Body of igniter 9. Air vent, filled with wax and sealed with tinfoil. | <ol style="list-style-type: none"> 10. Plug screwed into grenade body 11. Cardboard washer 12. Delay fuze, (4 to 5 seconds). 13. Igniter assembly tube 14. Bursting charge 15. Perforated steel disk 16. Igniter charge 17. Felt packing 18. Grenade body 19. Propellant attachment 20. Plug 21. Cardboard washer 22. Delay fuze 23. Igniter assembly tube 24. Bursting charge |
|--|---|

NOTE: This drawing is of the "Type 97", showing propellant attachment, for use with a grenade discharger. "Type 91" is not made with this attachment, but is otherwise exactly the same as above drawing.

Figure 4.—Japanese Hand Grenade (type 97).

CORRECTION

Figure 4 on page 10 should read Figure 3

The over-all length of the Type 91 grenade is 4 inches, and the maximum diameter of its body is about 2 inches. The body length is $2\frac{3}{4}$ inches, and the fuse length is $2\frac{5}{8}$ inches.

To fire this grenade, pull out the safety pin and strike the fuze on a hard object, such as a shoe heel, rock, or steel helmet. This action fires the cap and starts a delaying action of 4 to 5 seconds before detonation. Some of the fuzes have proved unreliable—they caused detonation earlier, or later, than usual. As a safety precaution, the grenade should be thrown immediately after striking the fuze on a hard object.

The simplest way to render the grenade safe is to replace the safety pin. If the safety pin is not around, insert a piece of wire, instead. Alternatively, either unscrew the fuse, or fire the grenade and throw it away to explode harmlessly. Do not allow the grenade to explode if this will give away your position to the enemy.

If it is necessary to disassemble the grenade, take the following steps:

- (1) Leave the safety pin in place. Unscrew the fuze (right-hand threads) from the top of the grenade.
- (2) Place a small screwdriver through the hole in the center of the top of the striker's retaining cap, and unscrew the striker as far as possible.
- (3) Remove the safety pin—it should come out easily. Remove the striker retaining cap; this action will leave the striker and striker spring free to be removed.

Assembly may be accomplished by reversing the above procedure.

This grenade can be used as a booby trap by placing it in the ground with its fuze up and pulling out the safety pin, so that it may be detonated by the weight of a man stepping on it. You must expect to find this grenade under planks, chair seats, or under anything else upon which you may walk or sit.

b. Type 97

This grenade, which has a propelling charge attached to its base, is designed primarily for use in the Japanese grenade dischargers (see *Intelligence Bulletin*, Vol. I, No. 9, pages 15-23, for details of the grenade dischargers and the types of ammunition used in them).

With the exception of the attached propelling charge, the Type 97 grenade is practically identical with the Type 91 (see fig. 3), and it may be fired as a hand grenade.

Practically all parts appear to be interchangeable. The propelling charge of the Type 97 is inserted or screwed into a hole in the base of the grenade. This hole is smooth in some of the grenades and threaded in others.

The steps in disassembling Type 97 are the same as for Type 91, plus the following:

- (1) Unscrew the propelling-charge assembly from the base of the grenade.

- (2) Unscrew the threaded bottom of the propelling-charge housing and remove the propelling charge.

c. Stick type

Few reports have been received from combat areas on this type of grenade—sometimes called the “potato-masher” type—and it is believed that the Japanese have used them very little so far in this war.

The stick grenade, except for an attached wooden handle used as an aid in throwing, is similar in size to the Type 91 hand grenade (see fig. 4). The over-all length of the stick type is 7.87 inches. The handle itself is about 5 inches long, and the diameter of the body, made of steel, is 1.97 inches. It does not have the rectangular notches.

The wooden handle, which has a small hole extending lengthwise through its center, is inserted and fastened at the top of the grenade. Fitted over the end of the handle is a tin screw cap, and under this cap is a ring tied to a piece of string. This string extends from the ring through the hole in the handle and is tied to a friction igniter in the fuze.

To throw the grenade, the thrower removes the tin cover from the handle, hooks the ring with his middle finger, and slings the grenade (the handle is not detached). When the friction igniter is pulled out by the string, the igniter activates a delay train. The latter burns for 4 to 5 seconds before it reaches the detonator, which, in turn, fires the bursting charge. The fragmentation of this grenade is believed to be poor.

A trip-wire booby trap can easily be made from this grenade. It is necessary only to attach a wire from the friction-igniter string to some movable object,

JAPANESE STICK GRENADE

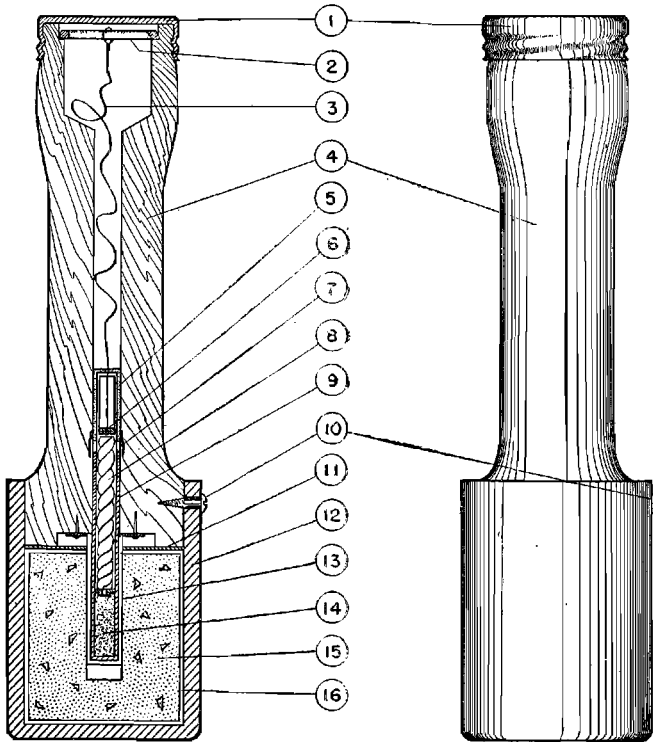

LEGEND

- | | |
|--------------------------------|-------------------------------------|
| 1. Pressed metal-cap. | 9. Fuze-igniter tube |
| 2. Ring | 10. Screws securing handle to body. |
| 3. Pull cord | 11. Waxed paper washers. |
| 4. Wooden handle. | 12. Grenade body. |
| 5. Abrasive material | 13. Waxed paper cylinder. |
| 6. Striker. | 14. Detonator. |
| 7. Vents, sealed with tinfoil. | 15. Bursting charge. |
| 8. Delay fuze. | 16. Waxed paper cover. |

Figure 4.—Japanese Stick Grenade.

such as a door, vine, or trip wire across a path or trail, or to a souvenir. To neutralize the booby trap, simply cut the wire, replace the ring in the handle, and screw on the cap.

4. ELECTRIC BOOBY TRAPS

Watch out for electrically detonated booby traps. Any vehicle, searchlight, generator, light circuit, or other electrical gear can be rigged easily so that the current will detonate an explosive charge. Before any captured equipment is handled, it should be examined for electrical as well as mechanical booby traps.

5. BANGALORE TORPEDO ¹

The Japanese Bangalore torpedo is not likely to be used in booby traps, but our soldiers should be familiar with its appearance and operation. The weapon consists of an explosive charge placed in a piece of common iron pipe, 2 inches in diameter and 40 inches long, with a cap on each end. It can be further identified by a red ring painted around the pipe.

To fire this type of Bangalore torpedo, a lanyard is attached to a braided cord which hangs out one end of the pipe; by jerking the lanyard, a friction igniter starts a delay train, which, in turn, sets off the explosive charge. There is a delay of 6 to 7 seconds, enabling personnel to take cover.

This weapon is used to cut barbed-wire entanglements—the fragments of the pipe sever the wire.

¹ Another type of Japanese Bangalore torpedo, with a bamboo body, is described in *Intelligence Bulletin*, Vol. I, No. 10, page 83.

Section II. NEW JAPANESE WEAPONS FOR INFANTRY SQUAD

I. GENERAL

For the purpose of increasing fire power, the Japanese Army for some time has been replacing the 6.5-mm (.256-cal.) weapons of its infantry squad with 7.7-mm (.303-cal.) weapons. These include the Model 99 (1939) 7.7-mm rifle and the Model 99 (1939) 7.7-mm light machine gun. They have been designed to take the place of the Model 38 (1905) 6.5-mm rifle, the Model 11 (1922) 6.5 mm light machine gun, and the Model 96 (1936) 6.5-mm light machine gun.

Details of all these weapons except the Model 99 light machine gun have been given in previous issues of the *Intelligence Bulletin* or in other Military Intelligence Service publications. An Ordnance study of the Model 99 rifle was published in *Intelligence Bulletin*, Vol. I, No. 7. The Model 96 machine gun is described in TM 30-480 (as revised Sept. 21, 1942), while the Model 38 rifle is described in TM 30-480 and also in *Intelligence Bulletin*, Vol. I, No. 5.

The Model 99 rifle and light machine gun both fire Model 99 rimless¹ 7.7-mm ammunition, which also is

¹ In *Intelligence Bulletin*, Vol. I, No. 7, p. 5, par. 2, line 4, change "semi-rimless" to "rimless."

adapted for firing in the Model 92 (1932) 7.7-mm heavy machine gun. This latter weapon originally was made to fire only 7.7-mm Model 92 semi-rimless ammunition. The Model 99 weapons will not, in turn, fire the semi-rimless ammunition, or any caliber .30 U. S. ammunition, or any caliber .303 British ammunition. Although originally designed to fire the semi-rimless ammunition, the Model 92 heavy machine gun has a somewhat higher cyclic rate of fire with the Model 99 rimless ammunition.

A muzzle velocity between 2,250 and 2,300 feet per second was obtained in firing the rimless Model 99 ammunition in the Model 99 rifle, the Model 99 light machine gun, and the Model 92 heavy machine gun.

On Attu whole units were found armed with the Model 99 rifle and light machine gun. On Guadalcanal a small number of the new rifles and new light machine guns were observed.

2. MODEL 99 RIFLE

The following notes on the Model 99 rifle supplement the information about this weapon published in *Intelligence Bulletin*, Vol. I, No. 7:

The Model 99 rifle is known to the Japanese soldier as *Kyu Kyu Tan Shoju* (99 short rifle). It is marked *Kyu Kyu Shiki* (Model 99) on top of the receiver, just below the Imperial Seal. It is capable of delivering deadlier and possibly more accurate fire than Model 38. However, the new rifle has a pronounced muzzle flash, which is not the case with Model 38. Model 99 also has a normal amount of recoil, which may affect the

marksmanship of the Japanese soldier, who is accustomed to the very slight recoil of Model 38. Because of this difference in recoil, some prisoners of war have stated that they prefer the old rifle.

The new weapon may be distinguished from the old by the following features:

- a. It is 5 inches shorter.
- b. A monopod mount, which is attached to the lower band and which can be folded forward to catch on the stock when not in use.
- c. A rubberized sling attached to swivels on the left side of the rifle instead of to the bottom.
- d. The slide of the rear sight has an arm extending to the left and one to the right for use when firing at aircraft. The arms, which, when opened, extend $2\frac{3}{8}$ inches from the center of the rifle, are folded upward against the sight during ground firing.

3. MODEL 99 LIGHT MACHINE GUN

a. General

The Model 99 light machine gun is a 7.7-mm version of the Model 96 light machine gun. The two weapons are very similar in general appearance, and the greatest care must be taken to distinguish them from each other. Many parts are common to both guns.

Model 99 (see fig. 5) is known to the Japanese soldier as *Kyu Kyu Keiki*, and is marked "*Kyu Kyu Shiki*" on top of the receiver.

b. Distinguishing Features

Model 99 may be distinguished from Model 96 by the following features:

- (1) A heavy, adjustable monopod, which is attached to an extension at the bottom of the butt plate.

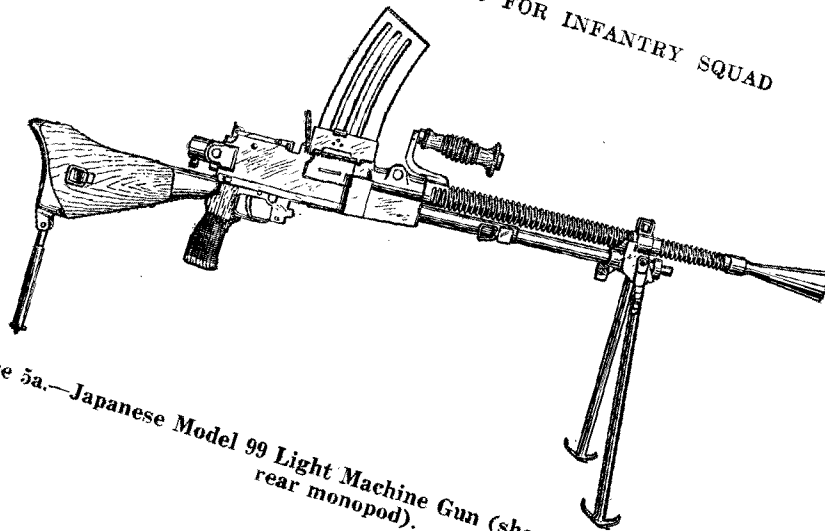

Figure 5a.—Japanese Model 99 Light Machine Gun (showing distinguishing rear monopod).

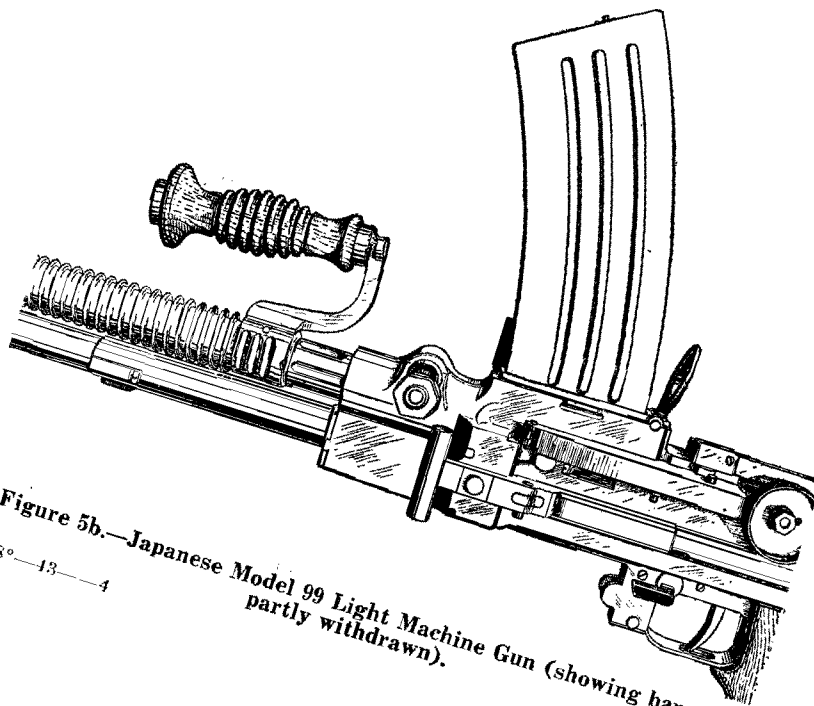

Figure 5b.—Japanese Model 99 Light Machine Gun (showing barrel partly withdrawn).

(2) A trigger safety which is located on the left-hand side of the trigger guard instead of on the right-hand side, as on Model 96.

(3) The method of locking the barrel to the receiver. On Model 99, the barrel locking bolt, which holds the barrel in the receiver, is held on by a heavy six-sided nut marked from 1 to 8. On Model 96 the barrel is retained in the receiver by a locking swivel, which has an outside handle lying parallel to the barrel.

(4) The flash hider of Model 99 screws onto the end of the barrel, which is threaded to receive it. The flash hider of Model 96 locks onto the barrel with a bayonet-type lock.

(5) The barrel of Model 99 is somewhat heavier than that of Model 96, but both are of the same length.

(6) The magazine of Model 99 is about 1 inch longer and somewhat less curved than that of Model 96.

c. Comment

Model 99 is considered a more effective weapon than Model 96, particularly because of the support given by the adjustable monopod at the rear and its heavier ammunition. It is believed that the effective range of Model 99 is possibly 200 yards greater than that of Model 96. The former has a high cyclic rate of fire, about 700 to 800 rounds per minute, in contrast to an estimated cyclic rate of 550 rounds per minute for the Model 96.

Section III. TYPE 98 AA/AT GUN

1. GENERAL

The Japanese Type 98 antiaircraft-antitank gun, 20-mm, is considered one of the enemy's best constructed and most efficient weapons. Most of its features were copied from a 20-mm rapid-fire gun manufactured by the Oerlikon Company, of Switzerland. In fact, some of the bearings in the carriage of a Type 98 recently examined by U. S. Ordnance experts bore a Swiss stamp. The Japanese weapon, weighing approximately 840 pounds, is relatively light and very maneuverable.

2. TABLE OF CHARACTERISTICS

Weight.....	840 lbs
Elevation.....	-9° to +81.9°
Traverse (pintle type).....	360°
Maximum horizontal range.....	5,450 yds
Maximum vertical range.....	12,000 ft
Rate of fire.....	120 rds per min
Muzzle velocity.....	2,720 fs
Length of barrel.....	70 calibers

3. DESCRIPTION OF COMPONENT PARTS

a. Tube

A stamp on the tube of the weapon examined indicated it was made in December 1940.

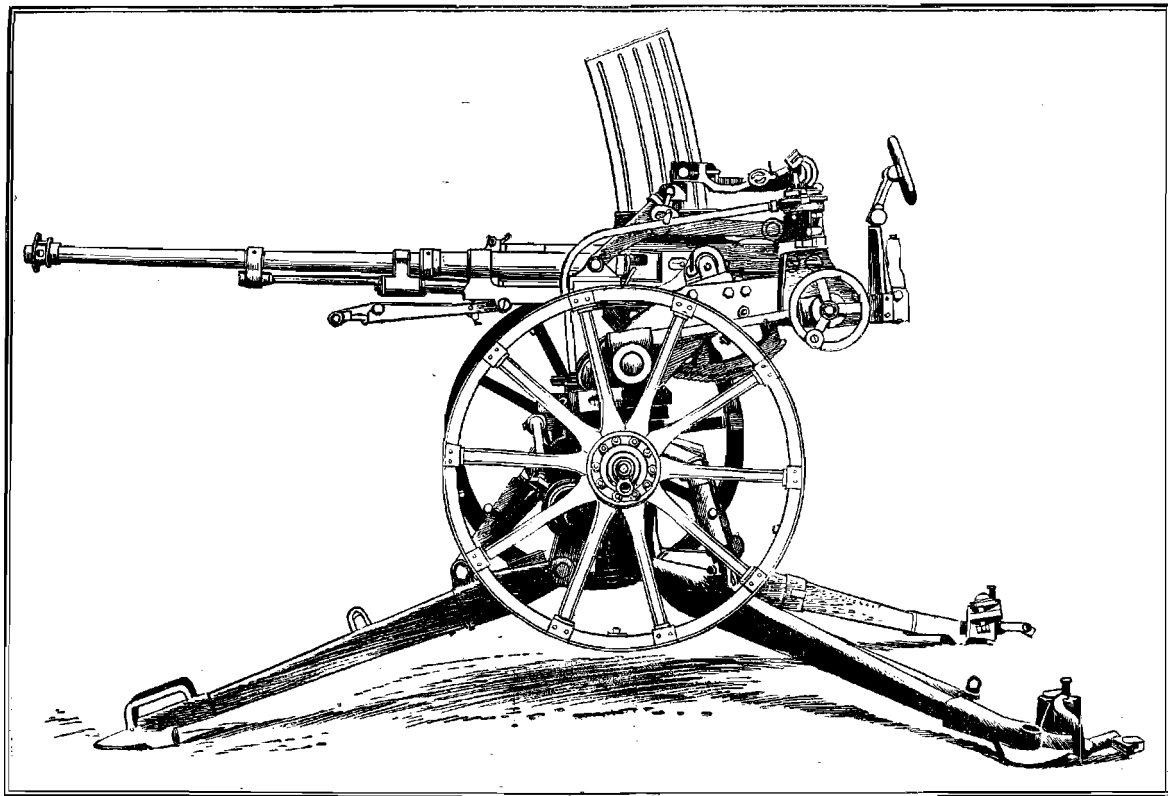

Figure 6.—Japanese Model 98 AA/AT Gun (20 mm).

The length of the tube is $57\frac{1}{6}$ inches with the muzzle brake, and $55\frac{1}{8}$ inches without it.

The locking of the tube to the receiver is accomplished by means of an interrupted thread bushing, which screws one-sixth of a turn into the receiver; this bushing is locked into position by a latch liner which fits into adjusting notches.

The muzzle brake is a large, flat ring, which extends out about 1 inch from the muzzle. The tube extension has holes (see fig. 6) to allow room for gases to expand. These gases leave the muzzle under very high pressure, and exert a force against the flat ring. This aids the recoil action, disperses the muzzle blast, and breaks up the flash.

b. Magazine

The magazine is of the vertical box type, and has a capacity of 20 rounds. It fits into a slot in the top of the receiver, and is held in place by a shoulder and spring catch.

c. Carriage

The carriage weighs 685 pounds, and, in its traveling position, has an over-all length of 9 feet. Its body has a road-clearance of 1 foot. The trails are the split type, and a detachable third leg (outrigger) is provided. The trails have fixed spades, with holes so that stakes can be used in stabilizing the gun.

The carriage has no shield. Its wheels are made of wood with iron or steel tires. The wheels, equipped with lug rings, can be detached easily.

d. Recoil System

This consists of two spring-loaded cylinders, which have valves in their forward ends. These valves allow air to be drawn in during recoil, and, since the air cannot escape readily, it acts as a cushion in easing the counterrecoil. The length of the recoil is estimated to be 2 to 2½ inches. It can be adjusted to a certain extent, but, once set, it becomes constant.

e. Sights

To date, no sights for this gun have been recovered. However, a report on the sight mount states that it has a small V-type open sight, with the head varying from about 2 to 8 inches from the notch. The mount has a mounting bracket for a sight of some type, and it is obvious from the accuracy obtained by the gun in combat that it is equipped with some type of modern telescopic sight. The small V-type open sight is probably used for initial aligning, or for short-range firing. It would be very ineffective as an open sight against aircraft.

The sight mount is rigidly fastened to the top of the carriage and to the sleigh by means of dovetailed, spring-locked mounting plates. The mount provides for setting in corrections, leads, deflections, and so forth, but how these devices operate cannot be thoroughly understood unless the actual sights are studied.

4. NOTES ON OPERATION

a. Getting into Position

It is estimated that an experienced gun crew could change the piece from a traveling position to a position for antiaircraft firing within a period of 3 minutes.

If necessary, this gun could be fired from its wheels as a split-trail artillery piece. In this case it could be placed in firing position from its traveling position within a few seconds. Under such conditions, the fire probably would not be very accurate. The weapon apparently is not designed for firing from the wheels, because it could not be cross-leveled, has no equalizer, and would be quite unstable.

The gun is placed into regular firing position from the traveling position by the following steps:

(1) The outrigger is attached to the front of the housing. This can be done rapidly because of the spring-loaded locking features.

(2) The axle is rotated to the rear, raising the wheels off the ground.

(3) The wheels are removed by releasing-spring catches on the axles. Removal of the wheels permits a 360-degree traverse at all elevations.

(4) The gun is cross-leveled by means of jacks on the outrigger and trails. The cross-levels are located on the upper carriage housing. The level vials are set in metal cylinders, which rotate one-half a turn and protect the vials when they are not in use.

b. Firing

In loading, the breech block strips individual cartridges from the magazine as the block moves forward and carries the shell into the firing chamber. As the shell is sealed into the chamber, its base is forced onto the extractor. (The extractor, spring-operated, is located at the bottom of the face of the breech block, and fits into a groove in the rear of the chamber.)

The gun may be fired either automatically or by single shots, depending on the position of a change lever, which is located at the bottom of the rear of the sleigh.

When the ammunition magazine is emptied, the bolt is held open by means of a spring-operated lever.

The gun has two safety features. The spring-charged lock on the firing handle must be pressed before the handle can be moved forward in preparation for firing. Also, the piece can be rendered "safe" merely by rotating the firing handle in a clockwise direction.

Section IV. JAPANESE COMMENT ON U. S. RESISTANCE IN PHILIPPINES

1. INTRODUCTION

An official Japanese Army document, recently acquired and translated, describes in some detail the fierce resistance put up by American and Filipino forces in defending the Philippine Islands. The document, dated "March 1943," apparently was written for the benefit of Japanese units expected to face U. S. troops for the first time in other theaters of operations. Except for editorial changes, the document is reproduced below in the same form as the original.

2. THE DOCUMENT

a. Fighting Spirit

The fighting spirit of the U. S. troops was unexpectedly high. Before our troops (Japanese 48th Division) landed on Lingayen Bay, they fought a tough battle with the Americans at the water line. We finally won, but only after the enemy had attempted to annihilate us completely.

After we had attacked Manila, we expected the Americans to surrender at a suitable time (after they had fought enough to save their reputation). However, continuing resistance on Bataan Peninsula, the enemy troops unexpectedly tried a strong offensive.

At the time of our second all-out attack on Bataan, we thought that the U. S. forces might surrender if we broke

through their front-line positions. However, they did not stop resistance until the last stage of the fight.

We thought that they would give up when we occupied the Bataan Peninsula, but they continued fighting under our successive artillery and air bombardments at Manila Bay.

Also, on Corregidor Island, they executed several counter-attacks before they were pressed into the entrance of the island's main base. They finally surrendered when everything was exhausted.

The main reasons why we won was because we landed a few tanks at a time when the Americans had no antitank guns with which to oppose us.

b. Command and Control

We admired the manner in which the Americans, under difficult conditions, commanded the Philippine forces until finally forced to stop resistance.

According to prisoners' notes, taken during the Bataan operations, there were many U. S. commissioned officers who bravely led native forces to the front lines. The rumor that only Philippine forces were used in the front lines is all false, because the Americans and Filipinos fought side by side.

c. Regarding Tanks

As a general rule, U. S. tank units moved forward bravely. In the vicinity of Carmen (Pangasinan), a certain U. S. tank officer, covering the retreat of enemy forces, resisted to the last and was taken prisoner with a mortar wound. On the Bataan Peninsula, our (Japanese) 16th Division suffered heavily from enemy tanks which moved through the jungle.

The front armament of U. S. tanks is so thick that our rapid-fire bullets do not penetrate. Also, the movement of enemy tanks was much superior to ours.

d. Regarding Weapons and Vehicles

U. S. rifles proved superior to ours. The enemy's automatic rifle was used very effectively against us. Soldiers equipped with the automatic rifle carried a large amount of ammunition.

The Americans have many different types of vehicles which are strong and superior. They transport all their weapons by vehicles, of which there are many special kinds.

e. Training

According to reports from Northern Tengen (Lingayen), native troops held rifle practice on the river lines prior to the invasion. We concluded that this training was very good because their shots were very effective all during the battle in that area.

Section V. COMMENTS ON JAPANESE BY BRITISH SOLDIERS

1. INTRODUCTION

The personal observations of several British officers and enlisted men on Japanese tactics and equipment as used in the Arakan campaign (Burma) are reproduced below. Some of the individual comments have been paraphrased to eliminate repetition. The comments represent the individual views of the men quoted, and are not necessarily the official British thought on the subjects discussed.

2. THE COMMENTS

a. Movement

Staff Officer: On the offensive in the jungle, the Japanese almost invariably select the most difficult routes by which to approach their targets. They move in small, self-contained detachments with their equipment, food, and other supplies. Each of these detachments sends out its own patrols and "feelers."

The Japanese objectives have invariably been the principal terrain features—high ground, roads, and strategically located villages. In order to gain these objectives, the Japs usually infiltrated into the British positions. Since the British did not have enough troops to man a continuous line in the area, the enemy was always able to infiltrate successfully. After forcing British withdrawals, the Japanese then brought up their rear units and attempted to repeat the process.

b. Patrol Tactics

Lieutenant: When meeting a British patrol in column during the day, it apparently was a standard practice of the Japanese to split their patrol and send one group to the left of the trail and another to the right. These groups then moved through the jungle and tried to cut off our patrols from the rear.

These tactics were successful when our men tried to go back toward friendly troops over the same trail by which they had come out. The Japs usually failed, at least in a large measure, whenever our men stealthily took to the jungle to wipe out the enemy, or forged ahead on their mission, without regard to their line of communications.

c. Deception

Platoon Sergeant: Shortly after the Japanese had launched a night attack—by throwing a few hand grenades, firing a few machine-gun bursts, and setting off some firecrackers—they sent a column marching down a hill by twos. When challenged by a sentry, the Jap leader made some evasive remark in a native Burmese dialect and kept marching. We fired on the column at a range of 10 yards. It immediately split left and right and charged our troops, using hand grenades and bayonets.

Staff Officer: On two occasions when the Japanese attacked in small groups, they drove herds of buffalo ahead of them. This tended to confuse our forces as well as to cover noises of the enemy approach. The Japanese followed the buffalo at a distance of about 20 yards, and thus were able to close with the unsuspecting defenders.

d. Use of Artillery

Staff Officer: All the Japanese artillery pieces fired to date in a certain area [in Burma] are believed to be the 75-mm mountain gun, which has a maximum range of about 9,000 yards.

To fire this gun, the Japs usually hauled it to the top of a hill. The high position is chosen because the enemy prefers simplicity in the conduct of fire, and because, it is thought, the gun is not very well adapted to clearing crests.

These guns usually fire only one or two shots for adjustment before firing for effect. They usually are fired singly or in twos or threes; except in one particular battle, more than four guns were never fired at any one time. In this instance the fire converged from separate localities.

The Japs frequently fire artillery and mortars at the same time, not only for the combined effect but to confuse our forces as to the location of enemy heavy weapons.

We know that some Japanese artillery ammunition is of an incendiary nature. The explosion of this shell produces an orange-colored burst with a large volume of black smoke.

The Jap high explosive shell has both a delayed-action fuze and one in which the fuze is only slightly delayed.

e. Use of Mortars

Sergeant Major: Time and time again, our troops, after having captured a portion of an area defended by the Japanese, were driven back by intense mortar fire which began as soon as the position was penetrated. The Japanese remaining in the area were not very much affected because they were dug in.

Staff Officer: It is known that the Japanese fire their mortars on fixed lines, the range to which is determined in advance. In firing on their own positions which have been penetrated or captured by opposing forces, the Japs in some cases have placed their mortars in deep holes, which were kept covered when the weapons were not in action. It is certain that from such positions the radius of mortar fire is limited. From the holes, a mortar could have been focused on one of the enemy's strongly constructed overhead-covered pillboxes.

f. Night Attacks

Platoon Leader: In the only Japanese night attack in which I participated, the enemy opened by firing a single heavy machine gun at us from a distance of about 100 yards. When our Bren guns returned this fire, the Japanese gun continued to fire straight ahead as usual, as a feint. At the same time, Jap infantry infiltrated between our guns—which had revealed their positions by firing—and attacked my platoon from the flanks and rear.

The Japanese are proficient at sneaking forward at night and, at dawn, lobbing rifle grenades on our positions from a range of about 200 yards.

g. Snipers

Private: Japanese snipers are often covered by another rifleman, who usually is a short distance to the rear. Most of the snipers we encountered were located in small pits dug under fallen trees, or under the roots of certain types of trees.

h. Communications

Company Commander: As means of signaling at night, the Japs have sometimes crowed like roosters and barked like hyenas. They also have frequently used red lanterns, and, in rear areas, red Very lights.

PART TWO: GERMANY¹

Section I. GERMAN RULES FOR USE OF CONTAMINATION BATTERIES

1. INTRODUCTION

If any proof of the importance of U. S. antigas training is needed, it is strikingly furnished by a German Army manual containing regulations for the employment of "contamination batteries." These batteries have the defensive mission of contaminating tactically important terrain with persistent gases. Significant extracts from the manual are given in this section. It is recommended that a previous *Intelligence Bulletin* article on German gas warfare (see Vol. I, No. 7, pp. 31-37) be read in connection with the following.

2. TERRAIN CONTAMINATION

a. Terrain contamination will be undertaken only on the order, or by the authority, of the High Command.

b. The attackers can seldom be completely stopped by terrain contamination alone. By means of increased and intensified

¹In *Intelligence Bulletin*, Vol. I, No. 11, p. 29, par. 3, a U. S. Army officer was quoted as saying: "Over 1,200 yards there was no use worrying about the 88. Its fire bounced off our medium tanks at that range." It has since been established, however, that German 88-mm guns constitute a danger to U. S. medium tanks at any range up to 5,000 yards.

fire, the defenders must follow up whatever advantage they have gained.

c. There are two types of terrain contamination: harassing contamination and blockading contamination.

Harassing contamination, which is the lighter form, will confuse the attacking forces and delay their advance. Patches, strips, and areas may be contaminated.

Blockading contamination delays the hostile forces even more effectively, and inflicts heavy losses on them as they work their way through. It consists of a thick network of contaminated patches, strips, and areas of great density, and is most effective when it covers a large zone.

By laying down a harassing contamination very quickly, the defenders can often gain time in which to lay down an extensive blockading contamination to the rear.

d. To deceive hostile forces, sham contaminations are useful. For this purpose harmless compounds, which resemble war gases in appearance and smell, will be laid down. The effectiveness of the deception will be increased if actual contamination is employed here and there.

e. Contaminated terrain must be filled with obstacles and dominated by fire, so that hostile forces, instead of being able to cross it quickly in vehicles or tanks, will be compelled to fight their way through it.

Combat patrols [German] will remain in the contaminated zone to hinder decontamination with their fire. These patrols will use contamination-free paths, or will go through the contamination, wearing light gas-proof clothing.

f. For tactical purposes, terrain is suitable for contamination if hostile forces are likely to consider it useful for observation and effective siting of weapons. Approach roads, bridges, entrances to woods and other localities, and possible assembly areas and communication centers are among the many types of places which lend themselves to contamination.

g. In carrying out contamination, remember the following points:

(1) Spray vehicles can be used only in areas that the hostile forces cannot cover with observed fire. If the hostile forces are able to employ observed fire, contamination must be carried out by means of portable spray apparatus.

(2) Before contamination is laid down, it will be advisable to select men from all units which are to fight a delaying action in front of the area to be contaminated, and instruct them how to guide their units to safety when a withdrawal is ordered.

(3) The contamination of terrain may be begun either on receipt of an order from the battery commander, or at a later hour fixed by him, or when the combat situation reaches a definite state foreseen and specified by the battery commander—for example, when the rearguard reaches a specified line.

(4) If full instructions regarding the contamination mission go down as far as squad leaders, the contamination can be carried out at night. However, much more time will be required at night than in the daytime. There is also the risk that, because of the difficulties involved in maintaining a satisfactory warning service at night, personnel belonging to other arms will wander into the contaminated area.

(5) Besides providing chemical troops to operate spray apparatus, the contamination battery will maintain sentries in front of contaminated areas and along contamination-free paths. All these men must know their missions precisely. They will be instructed to move direction signs and gap markers, either when they leave the area to assemble elsewhere, or in the event that hostile forces succeed in penetrating the area prematurely.

Section II. SOME BASIC PRINCIPLES OF COASTAL DEFENSE

Some basic German principles of coastal defense are summarized in the following notes, which were compiled by a German Army officer.

1. ORGANIZATION OF STRONG POINTS

Defense will be organized in the form of strong points. In the selection and organization of these strong points, the following questions must be taken into consideration:

- a. In which localities are landing facilities available to the opposing forces?
- b. Which landing beaches have good exits into the interior?
- c. Where are important installations situated, the possession or destruction of which would be of interest to the enemy?
- d. Which parts of the coast do not lend themselves to landing operations?

When strong points are to be organized in regions which lend themselves to landing operations, special attention must be paid to the following:

- a. Weapons must command the greatest possible stretch of terrain. However, there are two reasons why it is not advisable to site weapons on high points which overlook the general terrain; first the beaten zone is restricted, and, second, since the weapons cannot engage objectives within close range, the hostile forces can penetrate under the angle of fire.

- b. When there is a shortage of military personnel, the number of strong points which can be maintained will probably be so reduced that thorough observation of an extended coast-

line will be impossible. In the daytime, therefore, it will be necessary to place detachments with at least some degree of striking power between strong points. Whenever possible, the detachment should be a section, whose weapons include a light machine gun. Each man must be instructed in the methods by which an alarm is to be given if hostile forces approach. At night, patrols will use bicycles insofar as the terrain permits.

2. ORGANIZATION OF DEFENSE AREAS

Whenever possible, each company will keep a platoon in reserve. The machine-gun companies will be separated into platoons, and placed under command of the rifle companies. If circumstances permit, a machine-gun platoon will be kept in the rear with the battalion reserve. All heavy machine-gun personnel in the regiment should be reconstituted into heavy machine-gun detachments. [There are normally 36 heavy machine guns in a German infantry regiment.] Speedy communication between all strong points must be provided; telephone messages, direct or relayed, will be used wherever possible. If a defense area is so large that no company can be spared to serve as battalion reserve, all available personnel not ordinarily used for combat will be employed for counterattack. Each defense-area commander will have authority over all arms of the services within his defense area, and will incorporate in his defense plan a provision for utilizing all German Army personnel within the area.

3. USE OF ARTILLERY

Coastal batteries will be sited principally at those points where it is expected that the strongest resistance will be necessary. Batteries will not be placed in exposed positions close to the shore; they will be sited somewhat inland and under cover, but in such a way that they can engage the coastal belt during a landing. This will give better results than the engagement of targets at sea.

Plans must be made for coordination of artillery. All existing means of communication will be put to use, and radio sets will be kept as mobile as possible. The use of coastal batteries for firing in an inland direction will be successful only if observation posts have been installed. Map firing amounts to a waste of ammunition, and endangers our own soldiers.

4. CONDUCT OF BATTLE

Strong points will be defended, no matter what the situation may be, and even if hostile forces achieve a break-through. Local reserves will be used in the counterattack. If the counterattack fails, the opposing force's advance must be blocked from positions in the interior. These positions must be held until a planned counterattack by a larger reserve is successful.

NOTE.—The foregoing is of course general. Certain specific aspects of German coastal defense are discussed in the next two sections. The reader is also referred to the following M. I. S. publications: "German Coastal Defenses" (Special Series No. 15) and the forthcoming "German Doctrine of the Stabilized Front" (Special Series No. 17).

Section III. BARBED-WIRE OBSTACLES

1. GENERAL

With the German Army increasingly on the defensive, it is pertinent for us to know as much as possible about the enemy's employment of barbed-wire obstacles in continental Europe. A classic asset of the defense, barbed wire naturally plays an important part in the coastal and inland defense systems that the Germans are hurrying to complete in the occupied countries. The following aspects of German wire technique have recently been observed in France, The Netherlands, and Belgium.

On beaches, barbed wire is usually erected in straight lines, parallel to the shore and in front of fortified areas. Between these fortified areas, the lines of wire jut out at right angles toward the sea.

Around emplacements and fortified areas, the depth of wire obstacles varies, depending on the nature of the terrain and the importance that the Germans attach to the site. In some places the depth may range from 30 to 60 yards; in other positions, it may range from 70 to 130 yards, or may be as much as 200 yards. As a rule, the distance between the outside edge of the wire and the nearest pillbox or other firing position is at least 30 yards.

In gullies and in the crevices of cliffs, if ascent is considered at all possible, the Germans install dense wire entanglements. In front of these, the enemy sometimes places small-mesh wire, evidently for the purpose of slowing any advance in which Bangalore torpedoes might be used. Halfway up the gullies and crevices, the entanglements usually begin to thin out. Sometimes they continue as single fences running along the tops of the cliffs, near the margins.

In conjunction with road blocks, a wire fence or entanglement is often erected on each side of the road, and the gap between is closed by movable gates of various types. In many places concrete walls and other more substantial types of barriers are replacing wire entanglements as road blocks; however, wire is nearly always used on top of these wall barriers, for additional protection. Wall barriers and concrete emplacements are likely to have iron staples in them so that wire entanglements can be firmly secured.

Often the Germans use wire to fence off all sides of a minefield. Such fences consist of a single row of pickets connected by five or six strands of wire. Also, a thin belt of wire is commonly found outside antitank ditches.

The Germans are now making extensive use of a new type of barbed wire. This new type is made of a non-corrosive metal, and is thicker than ordinary wire. It is square in cross-section, rather than round. The wire, which is twisted, has $\frac{3}{4}$ -inch barbs, 4 inches apart.

2. SPECIFIC TYPES

The following are specific types of wire obstacles that the Germans are erecting in France, Belgium, and The Netherlands. Several of these types were encountered in North Africa, and any or all must be expected wherever the Germans have had an opportunity to prepare defenses. The dimensions given here are approximate.

a. Knife Rests

X-shaped metal knife rests, or "chevaux-de-frise," strung with wire, have been observed above the high water mark on beaches. Sometimes this type of obstacle consists of four trestles connected by a cross-bar, and has the following dimensions:

Height.....	4 feet
Span of trestle legs.....	4 feet
Distance between trestles.....	4 to 5 feet
Length of four-trestle unit.....	16 to 20 feet

b. Apron Fences

These may be single or double aprons. They are supported by screw pickets or by angle irons embedded in concrete to a depth of about 18 inches. Often a coil of concertina wire is placed under a double apron fence, and sometimes another coil is placed along the top. The dimensions of a typical apron fence are as follows:

Height.....	4 to 5 feet
Height (with coil on top).....	7 to 8 feet
Width.....	Up to 30 feet

c. Vertical Fences

Ordinary vertical fences are always installed in two or three lines, from 4 to 8 feet apart. Each fence has five or six strands of wire, and is 4 to 6 feet high. The wire is supported by wooden posts, angle irons, or screw pickets. The spaces between fences are frequently filled with wire entanglements and mines.

d. Concertina Fences

Single, double, or triple coils of concertina, supported by angle irons or screw pickets, are often used as fences. Triple coils are frequently affixed to the protecting rails of the beach promenades which are so common in the coastal towns of western Europe.

e. Trip Fences

Trip wires are often laid in front of important beach obstacles. These wires will usually be found between the high-water mark and the first barbed-wire entanglement. They are also used in the minefields in front of main defensive positions and main obstacles. Trip fences have the following dimensions:

Height.....	4 to 6 in
Length of each diagonal or diamond-shaped section.....	4 to 6 ft
Width of whole obstacle.....	12 to 20 ft

f. Alarm Wires

The Germans often place some form of alarm device in barbed-wire fences. Grenades and small explosive charges are common. Insulated live wire, which rings

a bell as soon as it is cut, has also been encountered. It must be remembered that almost any kind of improvised alarm device will serve the defenders' purpose, provided that it produces enough noise to warn effectively.

g. Electrified Wire

Electrified barbed wire, attached to pickets by means of insulators, has been reported. This type of obstacle is not used on a very large scale, however.

h. Combined Fences

A typical combined fence consists of the following units, in sequence: A trip wire, a trestle fence or knife rest, and an apron fence. The apron fence is likely to be from 10 to 20 yards behind the trestle fence or knife rest, and the total depth of the whole combination may be from 30 to 60 yards. On the sea fronts of towns, the Germans usually erect an apron or knife-rest fence on the beach, and a concertina or apron fence on top of the sea (retaining) wall or beach promenade.

3. STANDARD TECHNIQUE

The *Intelligence Bulletin* distinguishes between German technique which has actually been observed, and that which is prescribed in German training documents. Some notes regarding the latter are given below.

a. Obstacle in Depth

This type of obstacle is constructed to a depth of about 33 feet. It consists of ordinary wire fences erected at intervals of about 5 feet and connected with crisscrossed plain wire (see fig. 7). The spaces be-

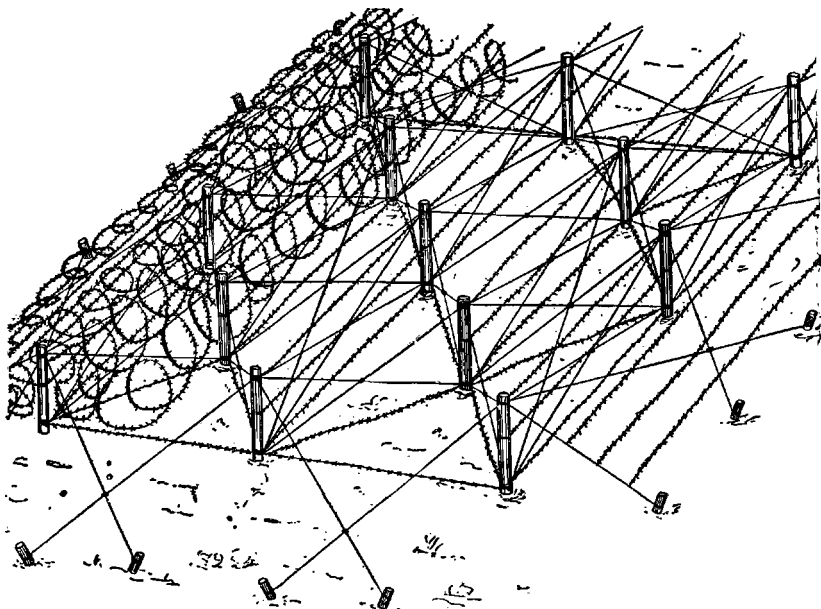

Figure 7.—German Obstacle in Depth.

tween the fences are filled with barbed wire in spirals. These spirals are fastened to each other and to the pickets of the crisscrossed wire. When obstacles of this type are erected in woods, trees are often used to support the wire.

Wire obstacles in depth are usually installed in places where they will be screened as far as possible

against observation by opposing forces. Woods, hollows, sunken roads, and heavily overgrown reverse slopes are sites especially favored by the enemy.

b. Wire-netting Fences

The Germans use wire netting as an emergency obstacle against infantry. They believe it to be most effective in woods and on the near side of hedges, and recommend that it be secured to the ground with wire and pickets. An obstacle of this type illustrated in a German training manual is 6 feet 6 inches high.

c. Trip-wire Obstacles

German training doctrine prescribes that these obstacles be at least 30 feet in depth. Irregular rows of wooden pickets, 2 feet high and 3 inches in diameter, are driven into the ground, and barbed or plain wire is stretched between pickets, at a height of 4 feet 8 inches. The interval between pickets in a row is 10 to 13 feet, and the interval between rows is 7 to 10 feet. Freshly cut pickets are painted to blend with the surroundings.

Trip-wire obstacles can be concealed effectively in gullies and on ground covered by low growth, especially if rusted wire is used. Mines and booby traps, equipped with pull-igniters, may be combined with these obstacles.

Section IV. TYPES OF CONCRETE ANTITANK OBSTACLES

This section deals with the principal types of concrete antitank obstacles erected by the Germans in the coastal defense zones of France, Belgium, and The Netherlands.

1. WALLS

a. General

The Germans make a practice of constructing concrete antitank walls in all coastal areas where a strong defense is planned. Walls of this type are used to block streets and roads in coastal towns, at the approaches to strategic points, and on the outskirts of towns, generally. Often the Germans prepare a continuous obstacle along the entire sea front of a town by constructing concrete walls in line with the front elevation of existing buildings. First, rough timber shuttering is erected along the site proposed for a new wall, and then the concrete is poured. Light steel reinforcement is sometimes used, but often there is no reinforcement at all. Often metal hooks project from the top of a wall, to serve as anchors for barbed wire (see p. 41).

To improve the effectiveness of a concrete antitank wall, the Germans often dig a ditch in front of the

obstacle or prepare a tank trap in the form of a pit covered with planks and gravel, or garnished netting.

In areas where there are quarries which can supply large quantities of stone, road blocks are often constructed of the native stone, instead of concrete.

b. Continuous Walls

When a continuous wall is erected along the sea front of a coastal town, a minimum thickness of 6 feet is the general rule. It is reported that the average thickness is from 8 to 11 feet. The height of such a wall is usually from 6 to 8½ feet.

c. V-shaped Walls

The Germans frequently erect V-shaped walls across the roads or tracks leading inland (through defiles between cliffs and dunes) from beaches. The point of a V-shaped wall is always toward the sea. These walls are especially common in open coastal stretches between towns. The dimensions of walls of this type are similar to the dimensions of continuous walls. It must be expected that the apex of the V will contain gun emplacements, or that the entire V will have been built to serve as a pillbox.

d. Walls with Gaps

When the Germans build a concrete wall with a gap, the gap is usually wide enough to allow only one vehicle to pass through at a time. The gap can be closed by means of girders, rails, or gates fitted into sockets imbedded in the wall.

It has been reported that in certain European coastal areas the Germans use an interesting type of staggered double road block. These obstacles consist essentially of a pair of walls or barricades, sited one behind the other, but projecting from opposite sides of a road. Each wall projects across $1/2$ or $2/3$ of the width of the road. These walls, which are never less than 6 feet thick, may be of masonry or concrete, or may simply consist of log barricades filled with earth or sand. The horizontal and vertical logs are about 1 foot in diameter. The vertical logs are driven deep into the ground, and additional resistance is provided by diagonal bracing. Obviously, such obstacles are intended to slow down advancing vehicles, and thereby render them much more susceptible to attack.

2. OTHER CONCRETE OBSTACLES

a. Dragons' Teeth

Concrete obstacles known as "dragons' teeth" are used by the Germans to block streets, exits from quays,¹ and well-defined beach exits where the level

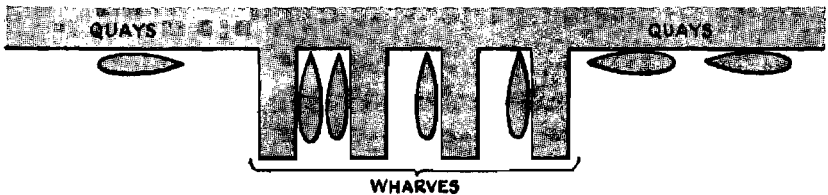

Figure 8.

¹ Figure 8 illustrates the difference between wharves and quays. The latter are very common in European ports.

of the beach is approximately the same as that of the roads leading inland. A typical arrangement consists of four to eight staggered rows of tapered dragons' teeth, with 6 to 8 feet between the teeth in each row and 6 to 8 feet between rows. Often the bases of the teeth are connected by concrete beams, in lines parallel with the road; this is a means of reinforcing the obstacles against possible overturning. The total height of these obstacles may be from 3 to 6 feet.

b. Plain Blocks

Plain concrete blocks are used in the same way as dragons' teeth, but are also found in defiles between sand dunes, which might afford an entrance inland for vehicles even though no well-defined road exists. These blocks are arranged in from one to three rows, and are not always staggered. In dune country they are also found on forward slopes, near the crests. The blocks may be rectangular (3 feet wide on each side and 4 feet high) or cylindrical (3 to 4 feet in diameter and 4 feet high).

3. RAILS EMBEDDED IN CONCRETE

In coastal towns the Germans often use straight or curved steel rails embedded in concrete to block ramps, promenades, streets, and all other exits leading from beaches. Sometimes three or four lengths of straight rail are combined to form a skeleton pyramid, with their bases embedded in concrete and the tops bolted together. Rail-and-concrete obstacles are generally from 3½ to 4½ feet high.

Section V. RECONNAISSANCE METHODS

1. INTRODUCTION

Russian fighting men have had excellent opportunities to learn about German reconnaissance methods. The information on this subject in the following paragraph has been collected and arranged by Lt. Col. L. Davidov of the Red Army. It should be of special interest and value to our junior officers and enlisted men.

2. ANALYSIS OF GERMAN RECONNAISSANCE

The Germans place great emphasis on reconnaissance. Dozens of orders and memoranda issued to German Army units include reminders that land reconnaissance must be conducted by all branches, regardless of whether or not this type of work is their primary responsibility.

During periods of inactivity on the fronts, German land reconnaissance attempts to learn:

- a. The location and extent of our defensive lines.
- b. The location and composition of our strong points.
- c. The differences between our day and night dispositions.
- d. The location of our obstacles and minefields.
- e. The movement and new positions of our units.

German land reconnaissance tries to report accurately and in detail the dispositions of our troops, heavy artillery, headquarters, and reserves. Regarding all changes in our units as significant, the enemy attempts to discover these changes and to draw conclusions which can be put to use. This reconnaissance

is carried out by observers, listening sentries, patrols, or battle (reconnaissance in force).

Special attention is given to the reports of the listening sentries. Under cover of darkness, these men crawl as close to our lines as possible, and try to plot and fix the location of various sounds—especially to gain information about our tanks, our reserves, the movement of our patrols, the location of our new artillery positions, and regions in which digging is in progress. Although the listening sentries can sometimes discover important data, we are repeatedly able to deceive them by means of ruses. Since the listening reports are checked in the daytime by German visual observation, we are obliged to deceive the visual observers, as well, for the sake of consistency. For example, if we imitate tank sounds at night for the benefit of German sentries in a certain locality, the next day we must see to it that there is some sort of camouflage in the same place.

Reconnaissance by combat patrols—usually a platoon—is most often done at night. These patrols, armed with hand grenades and machine pistols, generally operate without artillery support. They try to reach positions on the flanks of our units without attracting our attention, and then suddenly attack a previously assigned objective for the purpose of capturing a “tongue.” (In general, the objectives are those which have been discovered by lookouts and listening sentries). After capturing a number of outposts, the Germans send details of two and three men into our rear areas. Our wide-awake unit commanders often take advantage of these tactics for the purpose of counter-reconnaissance.

If the Germans are unable to locate our outposts and flanks, or believe them to be well hidden, reconnaissance by a patrol is preceded by artillery and mortar fire. Under such circumstances the raiding party is divided into attacking and supporting groups. As a rule, one or two small groups make a frontal advance, while the remainder attack the designated objective from the flanks. Two or three days before this type of

operation, the Germans place ranging fire on the objective and nearby positions. After this preparatory fire, the Germans do not fire again in this region until they are ready to attack. (However, during daylight it is not difficult to detect the movements of small groups of soldiers who are being instructed in the methods to be used for the attack and fire support. It is also fairly easy to detect a group of officers on a reconnoitering mission.) When the Germans are thoroughly prepared, they launch a night attack. If Russian units detect the approaching groups and open fire on them, the Germans signal for the previously prepared artillery and mortar fire.

Reconnaissance in force is the most ambitious of all German reconnaissance missions. As a rule, it is directed against a well-fortified position, and precedes an offensive. (Before such a reconnaissance, small groups, like those described above, will have tried to define the boundaries of the main objective.) The unit which is to perform such a reconnaissance may vary in size from a company to a battalion with artillery support. If the Germans expect to encounter unusually well-fortified positions with prepared obstacles, a unit consisting of combat engineers, heavy artillery, and a number of tanks is integrated into the reconnaissance party.

The Germans try to conduct a reconnaissance in force with all the speed they can achieve. If their first attempt is unsuccessful, they often repeat an attack, sometimes immediately after the first failure. Such an attack generally occurs during the second half of the night or at daybreak. During the daylight hours the objective is placed under intensified observation.

Characteristic methods of German reconnaissance are clearly illustrated by an action which was attempted against the Nth unit of our army. Two days before the time set for a reconnaissance in force, a group of German officers conducted a reconnoitering tour. That same day there was a brief artillery barrage, apparently for ranging. After this there was no action whatever in the sector—no doubt the scheme was to lull the

defenders into a sense of security. Two days later, during the second half of the night, the Germans opened concentrated artillery and mortar fire on the same sector. Under cover of this fire, a German reconnaissance unit, divided into three parts, advanced. Presently a German signal light went up, and the artillery fire was shifted to neighboring strong points. Simultaneously, two groups, supported by the small-arms fire of the third, made a quick rush on our trenches. We met the three groups with concentrated artillery and machine-gun fire. This forced the enemy to retreat. We have learned that when we can perceive the enemy's intentions, it is a good policy to allow these first groups to approach our positions so that we can annihilate the attackers at close range.

Finally, a word about German counterreconnaissance. Highly resourceful officers and soldiers are chosen for this work. These men take up positions as near our lines as possible. Their primary task is to determine the intentions of our reconnaissance patrols; their secondary task is to locate our minefields and learn the boundaries of our positions.

Section VI. FURTHER INFORMATION ABOUT GERMAN TANKS

1. ARMOR ARRANGEMENT

The sketches on the next three pages show the armor arrangement and armor thicknesses of the Pz. Kw. 3, Pz. Kw. 4, and Pz. Kw. 6. A question mark following a figure indicates that definite information regarding the thickness of a certain plate is not yet available. Two figures enclosed in parentheses indicate the presence of two plates, which are separated to form "spaced armor"; this arrangement occurs only twice, and only in the case of the Pz. Kw. 3.

2. SUBMERSIBLE TANKS

The delays and difficulties that the Germans have encountered in transporting tanks across the rivers of Eastern Europe have increased the enemy's interest in all possible devices which might enable standard Pz. Kw. to cross streams and rivers under their own power.

By the summer of 1941, the weight of the Pz. Kw. 3 had already been increased by additional armor, and it must have been clear to the Germans that future developments in armor and armament would necessarily involve still further increases in the weight of this tank. While the trend toward increased weight

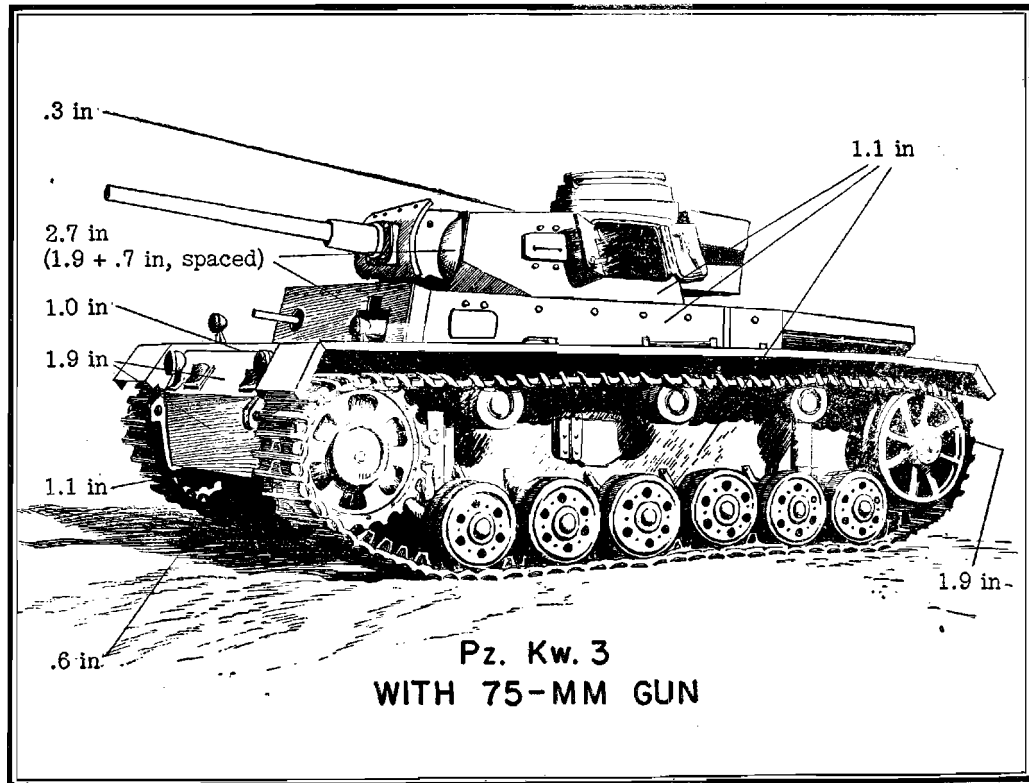
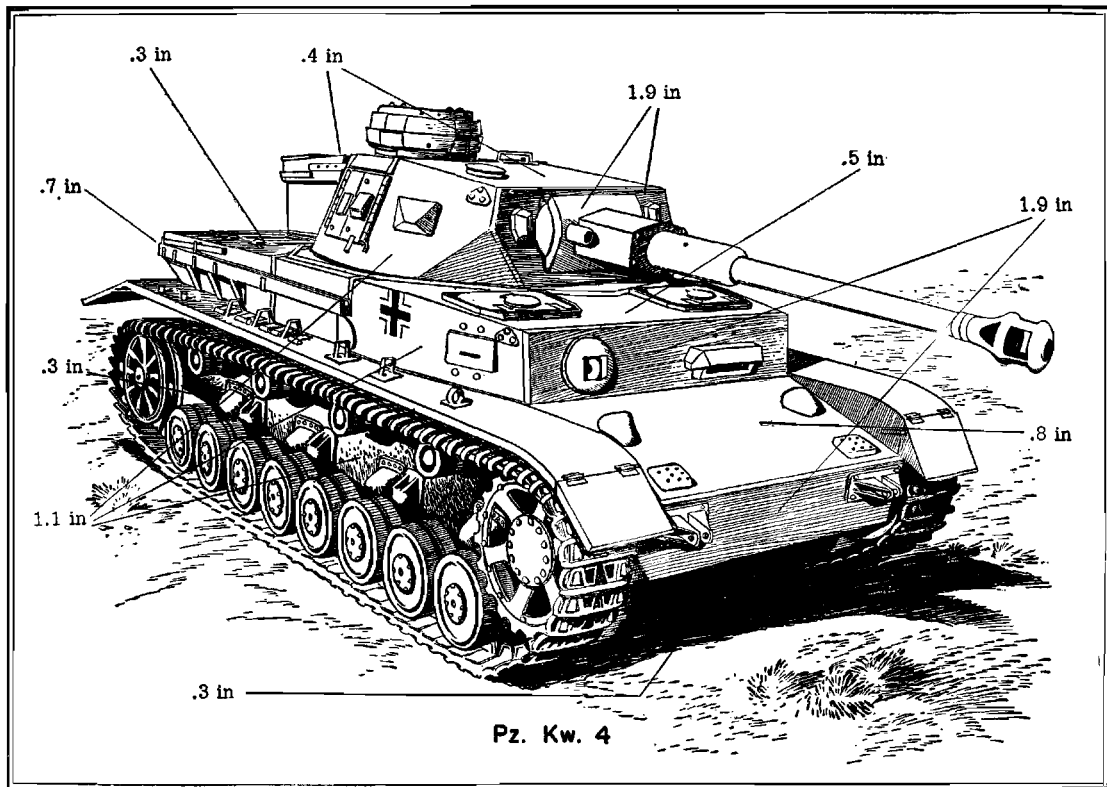

Figure 9.



Pz. Kw. 4

Figure 10.

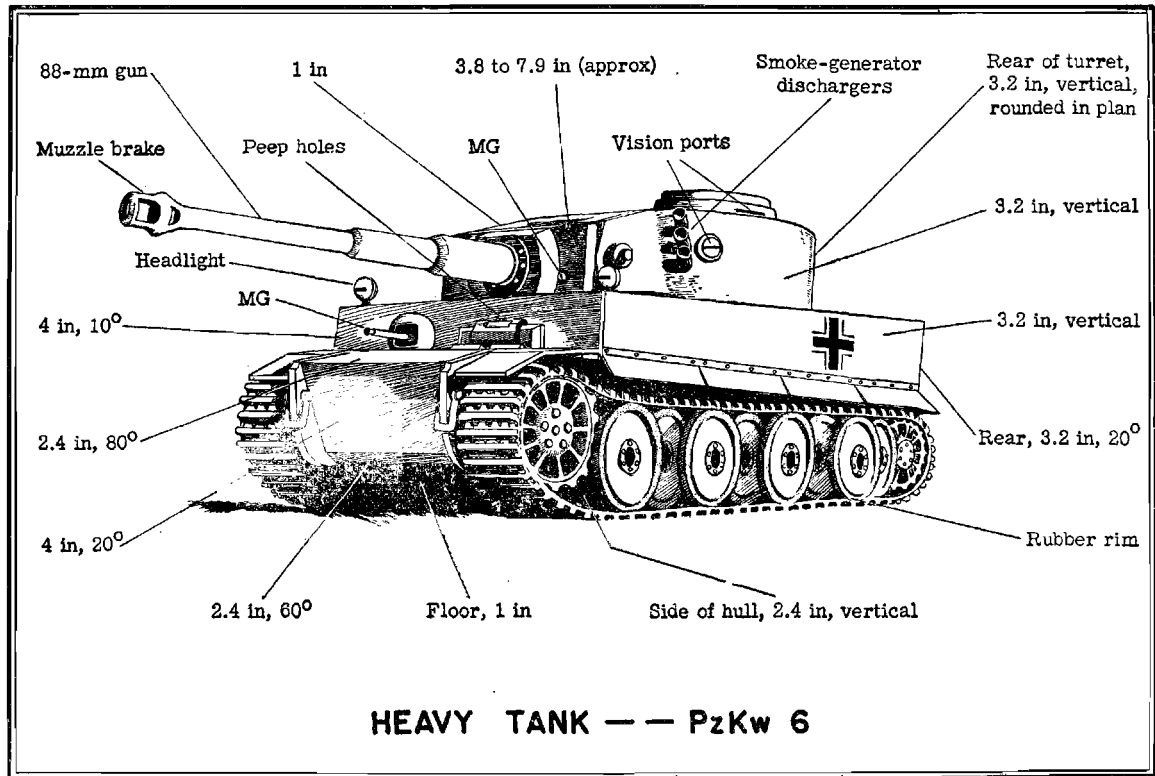

Figure 11.

was a disadvantage in many ways, it was definitely helpful in overcoming one of the biggest difficulties that the Germans had previously encountered in adapting standard tanks for submersion—namely, the difficulty of getting enough track adhesion.

It therefore is not surprising that the Germans, in the early stages of their campaign in Russia, were actively experimenting with standard Pz. Kw. 3's modified for submersion. It is reported that these experiments met with a certain amount of success, and that the modified tanks made underwater river crossings under combat conditions. The measures employed are said to have included the sealing of all joints and openings in the tank with rubber and the introduction of a flexible air pipe, the free end of which was attached to a float. The supply of air for the crew, as well as for the engine, was provided by this flexible pipe, which permitted submersion to a maximum depth of 16 feet. It took trained crews 24 hours to prepare the tanks for submersion.

In April 1943, a Pz. Kw. 3 (Model M) examined in North Africa was found to have been permanently modified for immersion, if not for submersion. Although reports on this tank did not mention a flexible pipe with float, such a pipe may have existed and have been destroyed by fire. The air louvres for the engine were provided with cover plates having rubber sealing strips round their edges. These cover plates, which were normally held open by strong springs, could be locked in the closed position by hooks before submersion. After submersion, the springs could be

released by controls inside the tank. When the tank submerged, air for the carburetor and cooling fans was apparently drawn from the fighting compartment. Therefore, if a flexible pipe was used with this tank, no doubt its purpose was to supply "replacement" air to the fighting compartment. The two exhaust pipes led to a single silencer mounted high on the tail plate, with its outlet at the top. This outlet was fitted with a spring-controlled, one-way valve, which could be kept in the fully open position during normal operation on land.

More recently, documents and reports from Russia have shown that the standard Pz. Kw. 6 (Tiger) is equipped for submersion to depths of as much as 16 feet. In this tank there is provision for hermetic sealing of all joints and openings. The doors and covers are provided with suitable rubber seals. The radiators are separated from the engine by a water-tight partition so that, when the tank is submerged, they can be cooled by water from outside the tank, after the cooling fans have been switched off. In this case carburetor air is drawn through a flexible pipe, the free end of which is supported by a float, but there appears to be no additional supply of air for the crew. A small bilge pump is also fitted to dispose of any water which may leak into the hull.

It is clear that the Pz. Kw. 6 requires only a slight amount of preparation by its crew before submersion, and that its design must have been influenced by the requirement that it quickly be made submersible. It is quite possible that the Pz. Kw. 3 could be submerged to

a depth of more than 16 feet if it were fitted with a longer air pipe. Although the Pz. Kw. 6 is not much larger than the Pz. Kw. 3, it is nearly three times as heavy, and track adhesion is therefore not likely to be a serious problem.

Section VII. MISCELLANEOUS

1. DIRECTIVE FOR DEFENSE OF POSITIONS

a. Introduction

A few months before the Axis capitulated in North Africa, the operations officer of the German Light Africa Division issued a significant directive. German officers in general—and junior officers, in particular—had been displaying certain weaknesses in defensive operations, and the operations officer was anxious to see an improvement in German tactics, especially with reference to the defense of positions. The document, which follows, has a special interest for us, inasmuch as it gives a clear indication of measures approved by the enemy, if not always practiced by him.

b. The Directive

(1) Each soldier must remember that the defense of a position will continue, if necessary, to the last man and to the last round. Every commander is fully responsible for the defense of the interdependent strong point assigned to him. It is not permissible, for instance, that the heavy-weapons platoon leader command the heavy weapons employed on the right flank of the company, as well as those on the left flank.

(2) All possible measures must be taken to prevent the opposing force from removing mines or other obstacles laid to the front of our position. Machine guns can be very effective for this purpose.

(3) All available machine guns are to be employed on the flanks whenever possible. At night the machine guns must command the entire terrain to the front. Shortly before dusk each machine gun—every light machine gun included—will therefore be sited so that it can cover a designated zone. The sector of fire will be marked by stakes on the right and left limits, and the elevation will be marked by a wire stretched horizontally.

(4) The heavy weapons and artillery will be so placed (in relation to the light infantry weapons) that their fire power can be directed primarily against important positions and terrain features which the opposing force might conceivably use during its approach.

(5) Officers of all grades will be held responsible for continuous preparedness for defense. Moreover, precise written orders are to be drawn up for each position. Each man must repeatedly be instructed in these orders, and must know them by heart. They must show, among other things:

(a) The position of the hostile force, the defense area, neighboring units, and the security toward the front.

(b) Day and night observation and scouting patrols.

(c) Supervision of order and alertness in the position, fire preparedness of the weapons, and the storage of ammunition.

(d) Action to be taken against hostile artillery fire (for example, "The soldier will take cover in his foxhole, with his machine gun or rifle.")

(e) Action to be taken against low-level air attack (for example, "Machine gunners will fire at their own discretion.")

(f) Action to be taken against thrusts by enemy assault troops (for example, "Alertness will be maintained to detect hostile feints.")

(g) Action to be taken in case of attack by infantry or attack by tanks.

(h) Action to be taken in case adjacent terrain is penetrated.

(i) Significance of pyrotechnic signals.

(j) Password.

(k) Security of communication net.

In forwarding this directive down to companies, the operations officer of the 200th Panzer Grenadier Regiment added, "The written orders mentioned in (5) are to be drawn up immediately for every defensive position, and will be presented to me, without further request on my part, whenever I make an inspection of the position."

2. BASIC INFANTRY TACTICS

A document issued by a German infantry division itemizes the essentials of German infantry tactical training. It is prefaced by a statement that in all situations the chief considerations are reconnaissance, protection, and the fire plan (ground and air). The document lists briefly the fundamentals of the approach march, the attack, and the defense. Certain similarities between German and U. S. tactics will be noted.

a. Approach March

- (1) The work of reconnaissance patrols must be extremely thorough.
- (2) Protection must be afforded by advance units (scouts, advance guards).
- (3) Fire protection must be provided in the assembly area.
- (4) The advance should be made by bounds.
- (5) The main body will be in the rear (commanders well forward).

b. Attack

- (1) Reconnaissance should lure targets into revealing themselves, and should deceive the hostile force as to the intentions of our own [German] units.

(2) There should be sufficient protection forward of the main attacking force.

(3) An organized fire plan is a necessity.

(4) The objective or task of each unit must be detailed.

(5) The point of main effort (*Schwerpunkt*) must be decided upon.

(6) *Details*.—(a) The first objective should be visible. (b) As far as possible, the advance should be made under cover. (c) The main effort must be made against an estimated weak point. The main effort must be so flexible that, regardless of the location of the weak point, it can be adapted in any sector to meet the situation. (d) All supporting arms must be informed of the intended point of breakthrough. (e) Reserves may also be brought forward into the flanking sector.

c. Defense

(1) The main line of resistance (*Hauptkampflinie*) is the forward edge of the main defensive zone. The main line of resistance is often referred to as including the general outposts (*Gefechtsvorposten*) and the covering positions (*Vorgeschobene Stellungen*), although both are in reality forward of the main line of resistance. The fire of all weapons must be planned so that it can be concentrated forward of, and within, the main line of resistance.

(2) It is the task of reconnaissance and observation to discover the intentions of the hostile force.

(3) The covering positions must conceal the actual location of the main line of resistance. The personnel manning the covering positions will fall back slowly, fighting a delaying action.

(4) The general outpost must goad hostile targets into revealing themselves, and then withdraw to the main line of resistance.

(5) The fire plan must include the coordination of the fire of all arms, arrangements for barrages and concentrations, the numbering of targets, and indications as to whether the tar-

gets are suitable primarily for infantry or artillery fire.

(6) *Details.*—(a) The fields of fire allotted to positions manned at night will be under the personal supervision of the company commanders. (b) Platoon commanders must be informed about all positions, and about the tasks of support weapons located in their sectors. (c) Each squad must have its own orders for defense. (d) The company commanders will determine the need for local reinforcements, and will arrange for defensive fires within their own sectors. (e) Only regimental commanders may order local withdrawals.

3. TANK RUSE TO DECEIVE ARTILLERY

U. S. artillerymen—and forward observers, in particular—will be interested in a ruse which was employed by a German tank unit in Tunisia. This tank force was located by a U. S. observer, who immediately prepared fire data to rout the enemy. Fire promptly got under way. At the second volley, the Germans put into operation a plan designed to confuse our artillerymen:

The Germans calculated the time of flight of the projectiles, and then listened for the report of the third volley. When it came, they shrewdly took the time element into account and fired their own tank pieces to conform with the strike of our own artillery fire. The Germans directed their fire first to one of their flanks and then to the other, at various ranges. Since our own artillery fire fell simultaneously in the same general area, our forward observer was unable to distinguish our fire from the enemy's and therefore could not register.

This continued for several minutes, with the artillery observer frantically trying to figure out the correct deflection and range. Then, by means of close observation, he discovered the technique that the Germans were using, and soon had them on the run.

As a U. S. soldier who took part in this action expresses it, "There's one thing we've always got to remember: in fighting the Germans, we're up against a cunning, imaginative enemy!"

4. HANDLING OF PRISONERS

It was a German practice in North Africa for units down to platoons to designate one or more soldiers who were to undertake specific escort duties if prisoners were captured. These designated soldiers were to cease fighting immediately, upon the order of their company commander or platoon leader, and were to take charge of the prisoners. It was stipulated that the following procedure be carried out:

a. The soldier in charge was to search all prisoners thoroughly immediately after their capture. The prisoners were to lay down all weapons, including pocket knives, at once. If this order was not complied with, the soldier in charge was to use firearms against the offenders.

b. If the tactical situation permitted, the prisoners were to be marched back, in formation, to the temporary battalion prisoner-of-war collecting point. Officers, noncoms, and enlisted men were to be marched back in separate groups. The escorting German sol-

diers, holding their rifles (with bayonets fixed) ready for action, were to march on either side, and to the rear, of the group. Prisoners attempting to break away and escape were to be dealt with immediately by the use of firearms.

c. Of the prisoners' possessions (besides their weapons), only documents, letters, plans, sketches, and photographs were to be confiscated.

5. "THIS MUST NOT OCCUR AGAIN"

The enemy's eagerness to capture U. S. documents is illustrated by this German divisional order, which should serve to remind *Intelligence Bulletin* readers of the paramount importance of security in the field:

Troops must pay greater attention to the collection of captured documents, and must submit them promptly to the proper authorities. Such documents include all official and personal mail found in the enemy's possession. It has been reported to the Division that filled mail bags belonging to the enemy have been left lying about and have not been brought in as booty. This must not occur again. Captured documents disclose important and reliable information concerning the enemy and provide clues to his formation, strength, and plans. These clues greatly facilitate our conduct of the war.

6. RAILROAD PATROL CAR (ARMORED)

In an effort to reduce the damage that Russian raiding detachments are inflicting on railroad tracks in German-held territory, the Germans are hastily improvising railroad patrol cars out of truck parts, captured Soviet reconnaissance vehicles, and the armor plate of partly destroyed tanks. The unorthodox result

is known as an "armored Zepp" (see fig. 12). An "armored Zepp" is employed to rush an assault detachment of Panzer Grenadiers to any section of a railroad where the presence of Russian demolition troops is suspected.

The Panzer Grenadier assault detachment can de-

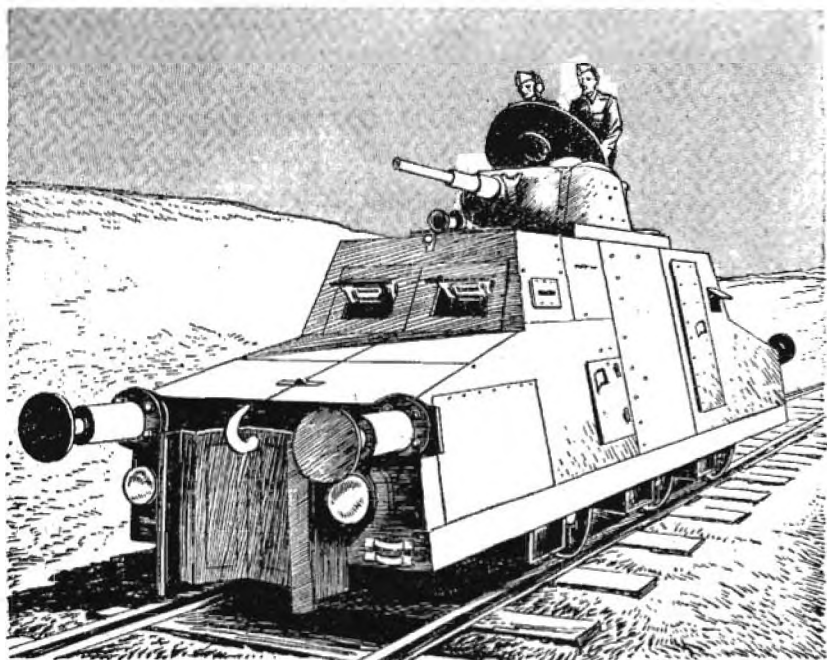

Figure 12.—German Railroad Patrol Car (armored).

liver fire from the railroad patrol car, and, equipped with rifles, machine pistols, and hand grenades, may leave the car to fight the hostile force. It is reported that sometimes the Germans also send supporting troops, who take up positions along the railroad embankment and give covering fire to the assault detachments, in cooperation with the heavy gun (37-mm

or 50-mm) of the "armored Zepp." Meanwhile, the assault detachment approaches the Russian demolition troops by bounds, and seeks to destroy them.

7. "WE CANNOT LOSE"

It is useful to know as much as possible, not only about the enemy's weapons and tactics, but about his mind and morale as well. On 6 December 1942 the following command order was issued to German troops in Libya; it illustrates clearly how the German Army tries to strengthen its soldiers' will to fight.

Now that we are no longer retreating, all unit commanders will place additional stress on discipline; on correct turn-out, with uniform caps worn in the regulation manner; and, above all, on military courtesy. Except when details are engaged in performing necessary fatigue, every minute of the training day should be utilized for drill. Also, unit commanders themselves will give instructive talks about the present political and military situation. These presentations will begin at once, and it will be emphasized to the troops that there is not the slightest reason for pessimism. The advantages of a shorter supply route and the importance of the Tunis bridgehead, which cuts off the enemy at the narrowest point of the Mediterranean, are to be explained to the troops with the help of a map.

The latest speech of the Führer should be quoted to show the troops that the war in Africa is only a small part of the German struggle for freedom and that, as the Führer has so clearly demonstrated, all advantages are, and always will be, on our side. Because we have all the factors of space, food supplies, raw materials, weapons, equipment, and manpower on our side, we cannot lose. We soldiers, who have an unshakable belief in final victory, should express this confidence and optimism in all our letters to the homeland. This will be the best news we can possibly send from the front.

8. RULES FOR LAYING TELLERMINES

The following extracts are from German Army regulations covering the laying of Tellermine fields:

The laying of Tellermines in open terrain will be influenced by the tactical purpose of the minefield, the nature of the terrain, the weather, the light conditions, the amount of time available, and the number of mines available.

Minefields are to be incorporated in the fire plan. Inasmuch as it is highly important that centers of resistance be established, it is advisable to lay several individual minefields, each having a narrow front and considerable depth, than to lay a continuous minefield of little depth.

Individual T-mine fields (company, platoon, and squad) are local minefields which, even under enemy action, are laid for a precise tactical purpose, according to the disposition of the company, platoon, or squad. As far as possible, they will be camouflaged. Unconcealed laying will be done only under exceptional circumstances—for example, when time is very limited or when there is an extreme shortage of manpower.

Continuous (as opposed to individual) T-mine fields are extensive fields, broken only by gaps and lanes for reconnaissance patrols, and are generally laid when hostile forces are not active. Continuous T-mine fields are always concealed and camouflaged.

The tactical situation and the supply of mines can modify the density of a minefield. This applies to camouflaged and uncamouflaged minefields, individual minefields, and continuous minefields.

9. NOTE ON CAPTURED MINES

All possible safety precautions should be observed in the handling, storage, and use of land mines captured from the enemy. It should be noted, especially, that German Tellermines stored in the open, where

direct sunlight and high temperatures can affect them, are likely to expand and burst. This results in exposure of the TNT with which they are filled. (See *Intelligence Bulletin* Vol. I, No. 12, pp. 8-14 for a discussion of German Tellermines, with sketches.)

10. DEVICE FOR STRANDED FLYERS

It has been reported that certain German aircraft crews stranded in the Mediterranean area have worn an unusual openwork headgear of white webbing,



Figure 13.—German Device for Stranded Flyers.

which is stiffened internally with steel wire so that the device can be fitted over the head and held in position (see fig. 13). Nineteen glass reflectors, each cut with 24 facets, are sewn to the webbing. These facets are intended to catch the sun's rays and reflect them to aircraft known to be friendly or to friendly forces on higher terrain.

PART THREE: UNITED NATIONS

Section I. LIVING IN THE JUNGLE¹

1. INTRODUCTION

To become effective jungle fighters, soldiers should study the problems of living and getting about in the tropics. They must look upon the jungle as a friend—it is just that when understood.

Almost the only thing to be afraid of in the jungle, or any other wild country, is fear itself. A soldier should not be afraid for two good reasons. First, the chances are 100 to 1 that there is nothing to be afraid of, and, second, a man afraid and therefore in a state of partial panic is useless in any situation. If you are dropped in a tropical jungle, in an unknown forest, or in the desert, the most important thing of all is to keep your head and calmly think out the situation. Fear is the last thing that will help you.

Remember that many of the things you have read about in these out-of-the-way places were written by men who went there in a spirit of adventure, and who practically without exception have emphasized, if not

¹ This section is based on three separate reports, one of which was prepared by the Smithsonian Institution, Washington, D. C.; one by the Division of Wildlife Management, U. S. Department of Agriculture, and the other by a British authority on jungle craft in Burma.

See FM 31-20, *Jungle Warfare*, for U. S. doctrine on fighting in the jungle.

actually invented, many of the thrilling experiences they relate. Thrillers are often a matter of the author's state of mind and not based on actual circumstance.

Most Americans, especially those born and reared in cities, are far enough removed from their pioneer ancestors to have lost the knack of taking care of themselves under any and all conditions, and it would be foolish to say that, without any training, they would be in no danger if lost in the New Guinea or some other Pacific island jungle. On the other hand, they would be in just as great danger if lost in the mountains of Western Pennsylvania or in other regions of our own country. The only difference is that a man is less likely to become panicky when he is lost in his homeland than when he is lost abroad.

Tropical areas are about the safest places a man can find if he is to be dropped without supplies. Animals scamper away, and you may travel for months without seeing any of those sometimes called dangerous. In fact, it should be something of a thrill and a challenge to your ingenuity to undergo such an experience. Work your way out slowly. Keep rested and avoid fatigue.

2. CLIMATE

The discomforts of tropical climates are frequently exaggerated. It is true that, on the whole, these climates are warmer than those in the temperate zones. The heat is more continual, or persistent, and, for this

reason, stories of excessively high temperatures have been circulated. In regions where the air contains a lot of moisture, the heat may seem more oppressive than it actually is. As a matter of fact, however, tropical travelers often complain that they have never experienced such heat and discomfort in the jungles as in some of our own cities in the summer time—Washington, D. C., for example. Also, strange as it may seem, there may be more suffering from cold in the tropics than from the heat. Of course, at ordinary altitudes, low temperatures do not occur, but chilly days and nights are common. At higher levels the nights may even be cold. The contrast between hot days and cold nights, however, is not as marked in forested areas as in the desert.

Rainfall in many parts of the tropics is much greater than that in all but a few areas of the temperate zones. Tropical downpours usually are followed by clear skies, and in most localities the rains conform to a fairly predictable time table. Except in a few areas where the fall may be continuous during the rainy season, there are not many days when the sun does not shine part of the time. Residents of the tropics usually plan their activities so that they are able to stay under shelter during the rainy and hot portions of the day. After becoming accustomed to it, most tropical dwellers prefer the mild and equable climate of the torrid zones to the frequent weather changes experienced in the more northerly climates.

In the jungles of Burma, the nights are cold enough from December to March to require a wool blanket

for cover while sleeping. A British jungle authority recommends that the sleeper pull part of the blanket over his head. This will induce deeper sleep, he says, and will have no harmful effects, since a person's blood does not require much oxygen while he is resting. A single blanket used in this manner will keep a soldier warmer than two used while his head is uncovered and while his lungs are inhaling lots of fresh air.

3. INSECTS

The harmful effects of tropical insects are generally overstressed. Malaria-carrying mosquitoes are by far the most harmful. It is fairly easy to contract malaria if a person fails to take the proper precautions. These include taking atabrine or quinine, wearing clothing that covers as much of the body as possible, using nets or screens at every opportunity, and avoiding the worst-infested areas when the tactical situation permits. Remember that mosquitoes generally fly in the afternoons and at night. They are most prevalent early at night and just before dawn. In uninhabited areas, malaria is much less likely to result from mosquito bites than in the populated places. Mud packs offer a certain amount of relief from the itching caused by mosquito bites.

Wasps and bees may be abundant in some places, but they will rarely attack unless you interfere with their nests. In case of stings, mud packs again are helpful. In some areas there are tiny bees, called sweatbees, which may collect on exposed parts of the

body in enormous numbers during dry weather, especially if one is sweating freely. They are stingless and, until one has completely stopped sweating, the only thing to do is to scrape them off with the hand, hundreds at a time. The honey made by these bees is not edible, as too much perspiration goes into its composition.

The larger centipedes and scorpions can inflict painful but not deadly stings. These creatures like dark places, so it is always advisable to shake your blankets before turning in at night, and to make sure before dressing that none are hidden in clothing or shoes. Spider bites may be painful but are rarely serious, and, as a matter of fact, are not often incurred. Ants are a possible source of danger to injured men lying on the ground and unable to move. This should be borne in mind in placing wounded where they may have to remain for some time.

In some localities certain butterflies collect to gather sweat from the human body in dry weather. They are somewhat annoying but quite harmless. In Indo-Chinese countries the rice-borer moth of the lowlands collects around lights in great numbers during certain seasons of the year. It is a small, plain-colored moth with a pair of tiny black spots on the wings. It should never be brushed off roughly, as the minutely barbed hairs of its body may be ground into the skin, causing a sore, much like a burn, that often takes weeks to heal.

4. LEECHES

Leeches are common throughout most of the islands in the Southwest Pacific and the Malay Peninsula. They are found in swampy areas, streams, and moist jungle country. They are not poisonous, but their bites may cause infection if not cared for properly, and the small wound that they cause may provide a point of entry for the organisms which cause tropical ulcers or "jungle sores." One should watch for leeches on the body and brush them off before they have had time to bite. When they have taken hold, they should not be pulled off forcibly; make them release themselves by touching them with a moist piece of tobacco (this is especially effective if some red pepper is mixed in the tobacco), by touching them lightly with the burning end of a cigarette or a coal from the fire, or by dropping some alcohol on them. Leeches try to reach mucous membranes and frequently enter the rectum or penis without attracting attention until an itching sensation begins. Urination usually removes them immediately from the penis, but medical help may be needed to remove one from the rectum. However, after satisfying their hunger, leeches frequently leave the rectum during defecation. This may produce a certain amount of blood flow, which may be mistaken for the beginning of dysentery or piles, but its short duration will remove all fears on that score.

5. SNAKES

The dangers from snakes in the tropics have been very much overemphasized. A person in the jungle probably will not see more than one or two snakes a month—and when he does, the view will probably be fleeting, as the snake most likely will be making every effort to disappear. There are no land snakes in the more remote Polynesian islands, and there were none in Hawaii until a minute, wormlike blindsnake was accidentally introduced there in recent years. Most of the islands of the East Indies have both venomous and non-venomous types. There are four kinds of snakes on the Fiji Islands, including one venomous variety. There are many kinds on the Solomon Islands, and Australia has an abundance of them, but nearby New Zealand has none. Only harmless kinds occur in the Galápagos Islands.

The poisonous snakes in New Guinea and the large neighboring islands are relatives of the Indian cobra, and their venom affects the nervous system (in contrast to most North American poisonous snakes, whose venom affects the blood stream). If you should accidentally step on one, you probably would be bitten. The chances of this occurring to persons traveling along trails or waterways are probably about the same as the chances of being struck by lightning. A large party, composed of some 700 men, traversed a considerable area in New Guinea some years ago and in a year's time none of them was bitten. New Guinea is as infested with poisonous snakes as any part of

Melanesia, but is probably a less dangerous area in this respect than New Mexico, Florida, or Texas, for example. This does not mean that one should be utterly careless about the possibility of snake bites, but ordinary precautions against them are sufficient. One should be particularly watchful when clearing ground for a camp site, trail, or the like, and also when roaming in the brush gathering firewood.

6. CROCODILES

“Crocodile-infested rivers and swamps” is another catch phrase about the Tropics. New Guinea certainly has its share of crocodiles, but authentic cases of their attacking human beings are not very numerous. Large crocodiles, particularly a species inhabiting Southern Asia and some South Pacific islands are likely to attack a person unless proper precautions are taken. As a rule, crocodiles are more apt to attack a dog or a small child than a grown person. If you approach or attempt to kill one along the shore, you should take care to avoid the powerful sweep of its heavy tail, which can break a man’s leg. Crocodiles are able to move swiftly in a straight line on land, but they cannot cover a zigzag course at a fast pace. If a crocodile chases you, dodge about while you are making your escape.

7. WILD ANIMALS

Jungle animals are by no means as dangerous as many writers of adventure stories would have us believe. In Africa, where lions, leopards, and such flesh-

eating beasts abound, it usually is necessary for photographers and others to obtain pictures of them on the large preserves, where the animals roam about as do the bears in Yellowstone National Park. In areas where the beasts are not protected, they are shy and seldom are seen—unless you have the aid of guides. When encountered, the one thought of the beast is to escape. All large animals, of course, can be dangerous if cornered, or suddenly startled at close quarters. This is especially true of females with young. The chances of this happening, however, are remote. The idea that big game hunting is dangerous is largely bunk. There are no carnivorous animals in the South Pacific, but in Sumatra, Bali, Borneo, and in Burma there are tigers, leopards, elephants, and buffalo. Ordinarily, these will not attack a man unless they are cornered or wounded.

8. POISONOUS VEGETATION ²

Another category of fictitious dangers deals with poisonous plants and trees. The truth of the matter is that nettles, particularly tree nettles, are about the worst that one will encounter, and one stinging from this source is sufficient to educate the victim to a ready recognition of the plant. There are some trees, which the Malays call “ringas,” the sap of which affects some people in much the same way as poison oak. Our own poison ivy and poison sumac, however, are much worse and much more likely to cause

² In connection with vegetation, reference should be made to TM 10-420, *Emergency Food Plants and Poisonous Plants of the Islands of the Pacific*.

trouble. Danger from poisonous plants is much greater in Golden Gate Park, San Francisco, or in the woods of our own eastern seaboard, than it is in New Guinea or the tropics anywhere. Thorny thickets, such as rattan, should be avoided as one would avoid a blackberry patch.

9. NATIVES

New Guinea and the Solomon Islands are popularly believed to be the haunts of headhunters and cannibals. Fifty years ago this was true, and it is true today to a much lesser degree in certain areas. A considerable portion of the interior of Dutch New Guinea is occupied by hostile tribes that are likely to be dangerous to small parties. This is particularly true of the natives of the interior lake plain, who are armed only with bows and arrows and who are so excitable that they are likely to reveal intended ambushes by shouting or firing their arrows too soon. If attacked, a small force armed with modern weapons should be able to disperse them without serious difficulty. There still may be places in the interior of British New Guinea where the natives are treacherous, but for the most part these have been brought under control. Headhunting and cannibalism are usually practiced at the expense of traditional enemy tribes, although strangers occasionally may be attacked without provocation. Generally you can get along all right with natives by treating them as you would your friends back home. This involves respect for privacy and personal property, and observance of local customs

and taboos. One should not enter a native house without being invited, nor should fruits be picked or sago trees cut without the permission of their owners. If one is tempted by the women of the wild tribes (and not many soldiers are likely to be), a case of venereal disease can be expected as a follow-up—this is one of the “benefits” of civilization conferred by the whites. Any native may be dangerous if badly or unjustly treated, or if undue liberties are taken with native women without regard to local custom.

10. EQUIPMENT

Everyone who knows the jungle strongly recommends that equipment be as light as possible. A British authority says:

You will require a haversack to carry rations and various other necessary articles. Take with you a small luminous compass, a small flashlight, matches and a cigarette lighter, a very small alcohol burner (to be used only when a wood fire cannot be safely made), and any small, light articles you desire. Consider carrying a very light sheet of oiled silk or cloth if rain is expected.

These articles—plus your rifle, ammunition, and rations—will hardly weigh 20 pounds. The temptation to take more is likely to be strong. Resist it, because every pound over this weight becomes a burden on a long march.

Other aids are practicable under certain circumstances. A well-trained dog may be a most efficient sentry, and even a messenger to your base. Carrier pigeons are invaluable aids to scouting parties working far behind enemy lines—for example in directing our planes to enemy targets you may discover.

Goats are silent, active animals which will follow you through all sorts of country. Each goat is capable of carrying 10

pounds of supplies. As a last resort, these animals may be killed and eaten.

The bark of various trees can be split and used as rope or string. For the same purpose, many small vines and grasses can be used.

The bamboo "tree" can be used for a variety of purposes in the jungle, such as mats, rafts, and cooking utensils. To make a mat, cut a large bamboo "tree" into sections of the required length and split each section down one side. Cut out the partitions, make lengthwise cuts near the joints, and then beat each section flat. These mats also can be used for walls and floors of huts. (Remember that the sharp edges of bamboo "wood" can cut you like a knife.)

To make a bamboo water container, select a section of a bamboo "tree" and cut just below the lower joint and just above the upper joint. Then cut a hole in the upper part of the section, and rinse out any loose particles inside. A carrying handle can be made by peeling a strip of the outer bark on each side, from the base to a point about two-thirds up the container, and tying the ends together above the top joint. For cooking or boiling water, fill the container as desired and then plug the hole with leaves. The bamboo will not burn out until the water is boiled and the food cooked.

A "stick" of rice for carrying with you can be obtained by using a section of small, thin-walled bamboo to cook it. Cut the section of bamboo as described in the last paragraph, fill it with rice and water, and boil. The surplus water will evaporate, and the rice will swell to fill the entire cavity of the section. After it has cooled, the section may be split open. The boiled rice will emerge in a stick form, covered with an edible film of silvery-white inner skin from the bamboo. The rice can be carried in this state, or left in the bamboo for added protection.

A frame for drying meat can be made by erecting four bamboo stakes and connecting them with pieces of split bamboo, which are tied to the stakes.

11. WATER

Water should be boiled about 10 minutes or otherwise made safe from various disease germs unless you are absolutely certain as to the purity of its source. In this connection, reference should be made to *Intelligence Bulletin*, Vol. I, No. 9, page 66.

Water can be freed of salt by filtering it through soil. Polluted water in a lake or pond likewise can often be made safe to drink by digging a well close to the body of water. The fluid content in the stomachs of animals is safe, and, despite its taste, is a nutritious substitute for water.

Many plants have water stored in their stems and leaves; the fluid is easily obtained by cutting or breaking the stems and by chewing the leaves or other soft parts of the plant. Many natives use a vine which they call "water rope." Each foot of the vine, when cut, yields about a teacup full of water.

In the forests of Burma, water is easily obtained almost everywhere. Many of the streams, however, have typhoid or paratyphoid fever germs, despite the fact that they appear clear and pure. Except for flowing springs, no water in the Burma jungles should be considered safe until it is properly treated or boiled.

12. FOOD

Food of some type is always available in the jungle—in fact, there is hardly a place in the world where food cannot be secured from plants and animals. All animals, birds, reptiles, and many kinds of insects of

the jungle are edible. Some animals such as toads and salamanders, have glands on the skin which should be removed before their meat is eaten. Fruits, flowers, buds, and often tubers, leaves, and bark can be eaten. Fruits eaten by birds and monkeys usually are acceptable to man.

A group of officers and enlisted men several months ago tested the possibilities of "living off the land" of a Southwest Pacific island (New Hebrides) while making a four-day reconnaissance in the jungle. Although rations for three days were carried by each man, very little was touched except tea and biscuits. It was conclusively proved that men who are resourceful and who will take the time to learn a little jungle lore can easily live and thrive healthfully in jungle country.

The group found the following kinds of meats: Wild chicken, wild duck, wild pigeon, wild cattle, wild pig, flying fox, fish, eel, and fresh-water crawfish.

The following types of fruits were found: Bananas (all year round), oranges (May, June, July), lemons (May, June, July), bread fruit (February, March), wild raspberries (September, October), Nakarika (October, November), papaya (all year round), and mangoes (February, October).

Vegetables—found to be available throughout the year—were taro, yam, manioc, hearts of palm trees, and the hearts of pandanus.

Coconuts are found all during the year, and navel nuts during September and October.

Natives used two methods in cooking fish. In one instance the fish, after being cleaned, were wrapped in wild banana leaves. The bundle then was tied with string made from bark, placed on a hastily constructed wood griddle, and roasted thoroughly until done. The second method was to wrap the fish in the manner described above, place the bundle well down inside and underneath a pile of red-hot stones, and roast.

Some of the meat cooked by the experimenting group was roasted in a hollow section of bamboo, about 2 feet long. Meat thus cooked did not spoil for three or four days if left inside the bamboo stick and sealed up.

Yam, taro, manico, and wild bananas were cooked in coals of fire. They tasted like potatoes—with a little stretch of the imagination. Hearts of palm made a refreshing salad, and papaya a delicious dessert.

In Burma, edible fruits and vegetables are not easily obtained, according to a British authority. Many fruits and vegetables are either not edible or are very bitter. Troops may find sweet potatoes or corn planted in a jungle clearing.

Meats in the Burma jungles may be obtained by killing such game birds as pea fowl, jungle fowl, pheasant, partridges, geese, and duck; and such animals as fish, deer, wild pigs, buffalo, and wild red ox. However, most of the latter do not move about much in open spaces during the day, are shy, and are therefore hard to kill. Buffalo and wild pigs, when wounded, may attack a person, and under some circumstances when not wounded at all.

13. SHELTER

Southwest Pacific natives have demonstrated how to construct a satisfactory bed and rain shelter in 15 minutes. The bed itself is made first, about 3 feet from the ground. Four forked stakes are driven into the ground, and a timber framework is placed upon the stakes. Then stout but pliable reeds are laid over the framework, and these, in turn, are covered with several layers of large, fine ferns. To construct the roof, four longer stakes are driven into the ground alongside the bed stakes, and the top is made in the same manner as the bed.

In Burma, the British warn against sleeping near a trail, game track, or stream, or on a ridge. These are jungle highways at night, and a tiger or other large animal might walk in on you. Go to the side of a hill away from game tracks, choose a dense thicket, make yourself comfortable, and rest without being mentally disturbed. The chances are very remote that anything will bother you.

The British also warn against sleeping in monasteries, or killing domestic cattle or chickens in front of the natives as it would offend Buddhist religious beliefs. Many monasteries have out-buildings for pilgrims or other travelers to use.

14. MAKING A FIRE

If you lose your matches or other fire-making devices, remember that a magnifying glass or any lens (including spectacles) will start fires by focusing sun

rays. The fine inner skin of dry bamboo is a good starting fuel.

Another quick method is to extract the bullet from a cartridge, replace it with a dry rag, cotton, or some other similar substance, and fire it onto the ground. The material used should catch fire and smolder.

If both these methods fail, you can always resort to the primitive practice of rubbing two pieces of wood together to fire a highly inflammable substance. Many primitive tribes have ingenious labor-saving gadgets to make fire by friction.

15. POINTERS ON OBSERVATION

The following notes on observation and reconnaissance were prepared by a British authority on the jungles of Burma.

Primarily, I would ask you to regard the ground on which you walk as the page of a book, or the page of a newspaper on which is written the news of all activities in and around the jungle. All movement of animals and men are marked by tracks and signs which you can interpret. Go out of your way to study the signs in soft ground, in the beds of streams, on roads and trails, and near watering places and salt-licks. Movement is seldom made without a reason; a few fresh tracks supply information about their maker, his direction, and probable intentions.

Animals fear men. Watch the animals, their tracks, and their behavior and you will learn the whereabouts of men. Listen to the cries of animals and learn to recognize their alarm calls.

A bird such as the lapwing, found in clearings near camps and villages, invariably gives away the movement of men by its loud and continuous cries.

16. MOVEMENT

In combat areas of the Burma jungle, it is best for an individual or small group to avoid the main road and trails and move through the forests. You will perhaps have a feeling of entering a maze. Don't let that disturb you. Consider that in these forests there are many animals as large or larger than yourself, and that they make and follow game trails, some of which are many years old. These game trails never run straight; they wind about and criss-cross the jungle; they lead to clearings, watering places, and salt-licks; and small ones may lead into larger ones, or merely vanish. Use these trails—don't strike across the jungle when there's a trail to assist you. The larger game trails follow the easiest terrain across hills, rivers, and swamps; and near these trails you will find opportunities to supplement your meat rations.

If no trails or paths are available, movement (in Burma) may be easier along drainage channels than along ridges. The reverse is generally true in other tropical areas.

17. MAINTAINING DIRECTION ³

Only a few of us have had enough experience to attain a "sense of direction" which comes to us instinctively. We therefore must consider various aids. The compass is an obvious aid, but, in the jungle, the

³ Reference should be made to the section on "Maintaining Direction" in *Intelligence Bulletin*, Vol. I, No. 4, page 69.

inexperienced man would never be able to move very fast if he had to make constant reference to his compass. It should be used as a last resort and as a check.

The shadows thrown by the sun are an easily observed and accurate aid to direction; but one must allow for the gradual displacement of shadows as the earth moves around.

Other aids to maintaining direction include prominent objects, the course of rivers, prevailing winds, the stars, and the moon.

Section II. BRITISH USE OF TANKS IN JUNGLE WARFARE

1. INTRODUCTION

Tactics evolved by a British Army unit in India for the use of tanks in jungle warfare are given below. This information, published as a training memorandum several months ago, represented the thought of the British unit at that time, and it should not be regarded as the latest official British doctrine. The use of this document is felt to be timely since it may stimulate expression of U. S. opinion on the subject.

The memorandum emphasizes that tank, artillery, infantry, and engineer troops should train together to develop teamwork, confidence, and understanding. In jungle warfare, the British unit felt that large numbers of tanks will seldom be able to deploy sufficiently to develop their full fire power, and much of their work will be done in close cooperation with the infantry. It must be realized that, in the jungle, tank movements are largely confined to roads or trails.

2. THE MEMORANDUM

a. The Approach

During the approach march, most of the tank strength should move in a close, compact group, some distance back of the for-

ward troops. One tank platoon (four tanks) should move near the head of the troop column so it can cooperate immediately with the leading infantry soldiers in case of contact with the enemy. (The four tanks are considered the maximum number that should be deployed on the initial contact.) Tanks should not lead the column; they are too easily held up by demolitions and obstacles that they cannot by-pass without engineer assistance. In more open country, where they can deploy, tanks should lead, preceded by their own reconnaissance unit. Not less than a company must be employed for reconnaissance, and it should be followed closely by at least one company of infantry.

b. Attack

In the frontal attack, in thick jungle, it is unlikely that the tanks will be able to leave roads or trails; therefore not more than one platoon will be used in the attack itself, although more should be available and ready to exploit success. The actual method of attack is governed by the amount of fire support available. If it is considered sufficient to neutralize enemy antitank fire, tanks can slightly precede the bulk of the infantry, which, however, should follow closely. Where less fire support is available, the arrival of the tanks on the objective should be timed to coincide with that of the infantry. In either case some infantry should advance on either flank level with the leading tanks to prevent enemy tank-hunting parties—which may have survived the artillery barrage—from attacking the tanks with grenades or other similar weapons. In addition to the barrage and the close escort of infantry, it will often be necessary for tanks to cover their advance with smoke from their own projectors, or, if these are not fitted, from mortars.

This form of attack requires very careful timing and must be practiced as a drill by all infantry, inasmuch as the motor battalions in armored regiments cannot put sufficient men on

the ground to deal with a strongly held position. Artillery and engineers must also know their exact roles in this operation; the former can often use a tank as an observation post. In the encircling attack, in thick jungle, tanks will assist in exploitation, once the road (or roads) is cleared. In either form of attack, the mere presence of tanks is of great morale value to the infantry.

In the more open spaces in jungle country, the primary role of tanks is to deal with any hostile armored-force vehicles that are encountered; the tanks should not be dispersed for reconnaissance missions that can be performed by the motor-battalion carriers or their own armored-car patrols. If tanks are required to take part in an attack on enemy positions in the open, only the heavier types should be used, unless fire support is overwhelming and unless it is reasonably certain that enemy anti-tank weapons have been neutralized. Infantry troops can often be transported on the tanks to within reach of the objective if it is not possible for them to get there in their own vehicles. When woods, gullies, and other cover are being cleared, tanks will operate on the flanks and rear in order to deal with any enemy driven into the open. In village fighting, tanks should move in support of the attacking infantry and must also be used to watch all exits. They must never be sent into villages, unless preceded by infantry. If required to assist or take the place of artillery in providing fire support for an attack on a village, tanks should use high-explosive and not armor-piercing projectiles.

c. Defense

Where the terrain is suitable, tanks should always form part of the striking force from defended areas. If time allows, clearings should be made and trails improved for the use of tanks in this role. If not employed in this role, tanks should be held in reserve for counterattacks.

d. Withdrawal

In thick jungle, tanks can do little or nothing to hold up the enemy, but in more open country they can impose considerable delay, either by counterattacking or by threatening the head of his column. In this way they can help our retiring troops to break off contact, and, in an emergency, tanks can ferry out the rearmost parties of infantry. Enough tanks must be employed to watch both flanks, and, if carriers are not available, a proportion must be used to keep open the roads to the rear.

"In the hands of junior officers lies the fate of an Army. You are in direct, immediate command of the troops. You are their inspiration and leaders. All of you are fighting for the right to live as you please as long as you don't get unjustly in other people's hair. You are fighting against dictation and dictators. Only discipline will win a war. Victories come from discipline. And discipline comes from the everlasting efforts of the junior officers."

—Gen. Dwight D. Eisenhower.

