

HANDBOOK OF ENEMY AMMUNITION

CONTENTS TABLE

German Ammunition

| | PAGE |
|--|------|
| Tellermine (T.Mi.35) | 3 |
| Fuze T.Mi.Z.35 for Tellermine | 6 |
| Pull Igniter Z.Z.35 | 9 |
| S/30 Mechanical Time Fuze (Zt.Z.S/30) | 11 |
| S/30Fg ¹ Mechanical Time Fuze (Zt.Z.S/30 Fg ¹) | 16 |
| Fuze A.Z.38 | 24 |
| Fuze for 3.7 cm. H.E. Shell (3.7 cm. Kpf. Z. Zerl. P _e) | 26 |
| Gain 40 (Zündladung 40) | 28 |
| 5 cm. Kw.K, Cartridge, Q.F., A.P.C. (5 cm. Kw.K. Pzgr. Patr.) | 29 |
| 7.5 cm. Kw.K and Stu.G., Cartridge, Q.F. Hollow Charge 38 (7.5 cm. Gr. Patr. 38 Kw.K) | 32 |
| 7.5 cm. L.G.40 Q.F. Cartridge (7.5 cm. L.G.40 Hülsenkart) | 35 |
| 7.5 cm. L.G.40, Hollow Charge Streamlined Shell, 38 (7.5 cm. Gr.38 Hr/B) | 36 |
| 7.5 cm. Light Infantry Howitzer H.E. Shell (7.5 cm. Igr.18) | 38 |
| 7.5 cm. Light Infantry Howitzer H.E. Shell (7.5 cm. Igr.18 Al) | 40 |
| 7.5 cm. Pak 40 and Kw.K40 A.P.C.B.C. Shell 39 (7.5 cm. Pzgr.39) | 42 |
| 7.62 cm. F.K.296(r), Cartridge, Q.F., H.E. (Russian origin) | 43 |
| 10.5 cm. I.F.H. 18, Hollow Charge Shell 39 (10 cm. Granate 39 rot. Hl.) | 47 |
| 15 cm. Medium Howitzer Q.F. Cartridge (15 cm. s.F.H.18) | 49 |
| 15 cm. Medium Howitzer Anti-Concrete Shell (15 cm. Gr.19 Be) | 51 |
| 21 cm. Heavy Howitzer Q.F. Cartridge (21 cm. Mrs.18) | 53 |
| 21 cm. Heavy Howitzer Anti-Concrete Shell (21 cm. Gr.18 Be) | 54 |

Italian Ammunition

| | |
|---|----|
| H.E. Hand Grenade, S.R.C.M.35 | 57 |
| 75/27 Hollow Charge Streamlined Shell | 60 |

Hungarian Ammunition

| | |
|---|----|
| Anti-Tank and Anti-Personnel Mine with Variable Pressure Fuze | 62 |
|---|----|

Index

| | |
|--|----|
| Pamphlets No. 1 to No. 8 inclusive | 67 |
|--|----|

HANDBOOK

OF

ENEMY AMMUNITION

GERMAN TELLERMINE 35

(Fig. 1)

The mine is designed to function by pressure applied to a contact fuze (T.Mi.Z.35) in the cover plate or by detonators in the side and base which may be initiated by "booby trap" devices (Z.Z.35) or a length of instantaneous detonating fuze connected to another mine.

The body of the mine, containing 11 lb. 6 oz. of T.N.T., is circular with a flat base and a convex head which is fitted with a convex cover plate through the centre of which the fuze protrudes. The sockets and containers for the disturbance initiator devices are situated one in the base and the other in the side. The diameter of the mine is approximately 13 inches and the height, including the fuze, is 3.9 inches. The mine and cover plate are painted a dull red and the assembly camouflaged with green and brown paint. A lifting handle is fitted at the side. The weight of the complete mine is approximately 20 lb.

Body

The body is made in two main parts, the cylindrical charge container with convex head which is stamped from sheet steel, and the flat steel base plate. Strips for the attachment of a hoop are spot welded at eight spaced positions around the side of the charge container. The head is shaped at the centre to form a recess for the fuze and the cover plate spring, the base of the recess being closed by the socket for the main detonator container. The socket is fitted with the container at its base and is threaded internally for the closing arrangement. This arrangement consists of a number of washers inserted above the detonator and compressed by a screwed plug with a central flash hole. An adjusting screwed plug is inserted to bear on the first plug and is locked to it by a fixing screw. The second plug carries a rubber sealing ring on its upper surface which is compressed by the base of the fuze. The flash hole formed in this upper plug coincides with that in the lower plug and is shaped to form a neck by a reduction in diameter near the top. The socket and container in the side of the body is of a

GERMAN TELLER MINE 35.

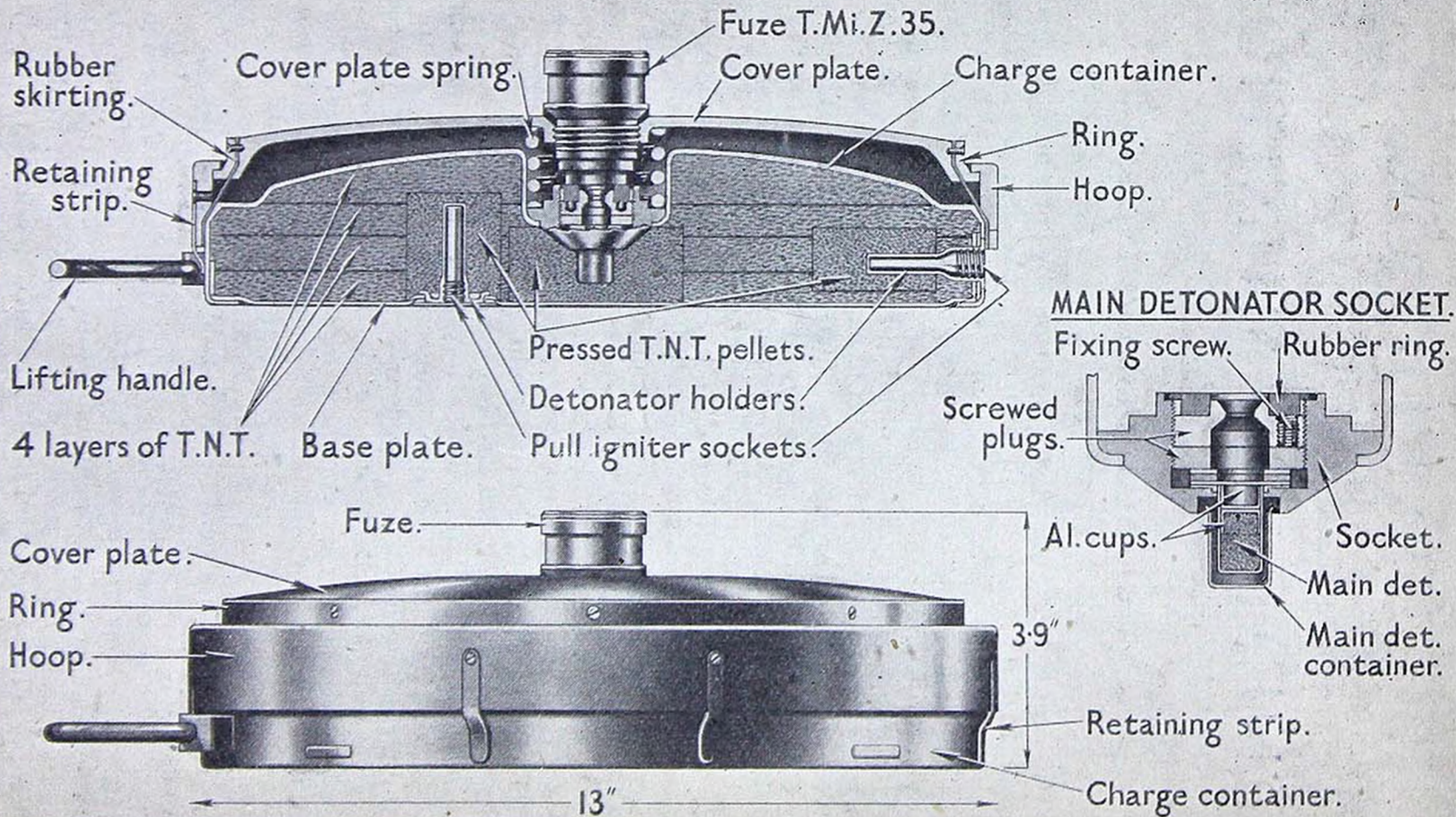

FIG. 1

suitable size to take the German type of No. 8 detonator and is screwthreaded for the insertion of a pull igniter (Z.Z.35). The base plate is shaped to form a step near the circumference. The plate is attached after the mine is filled by turning over the rim of the charge container on to the step formed on the plate. The joint is completed and made watertight by the application of a fusible alloy. The inside of the charge container and of the base plate is coated with black varnish.

Bursting Charge and Exploders

The bursting charge consists of 10 lb. 13 oz. of cast T.N.T. filled in four layers with a density of 1.58. The T.N.T. appears to have been cast in the "creamed" condition, i.e. as a semi-fluid mass consisting of a suspension of fine crystals which had solidified from the melt before pouring. This method has the advantage of reducing cavitation and ensuring a good density.

Three unwrapped recessed exploder pellets of pressed T.N.T. crystals are inserted in the process of filling to form surrounds for the three detonator containers. The pellets have a density of 1.45 and are of the following weights:—

| | |
|-----------------------------|----------------------|
| Exploder for main detonator | — $3\frac{3}{4}$ oz. |
| Exploder for side detonator | — $2\frac{1}{3}$ oz. |
| Exploder for base detonator | — $3\frac{1}{4}$ oz. |

Mines of a later date of filling have a plain cast filling of T.N.T. and exploders of pressed T.N.T. flake.

Cover Plate

The cover plate is supported on a spiral spring which is located in the recess in the top of the body. The plate has a central hole, threaded to take the fuze and carries a rubber skirting attached round its tapered periphery by means of a tapered ring secured to the plate by screws. The lower part of the skirting fits over a chamfer formed round the body at the top of the wall and extends down over a part of the cylindrical wall. The skirting is held in this position by a surrounding hoop which is shaped internally to conform with the cylindrical wall and chamfer of the body and is provided with an internal shoulder at the top to engage the flange of the cover plate. The hoop is secured to the body by screws which are inserted through a hole near the upper end of each of the eight strips attached to the body and screwed into the hoop. The lower edge of the hoop has a semi-circular piece cut away at one point to provide access to the detonator holder in the side of the body.

Another type of cover plate met with consists of two superimposed convex plates connected at the centre by a threaded fuze-hole bush. With this type the rubber skirting is held between the two plates and an outer cover plate is used which fits over the assembled cover plate and overlaps the top of the hoop.

Fuze and Pull Igniter

Details of the fuze, T.Mi.Z.35, and the pull igniter Z.Z.35 are included in this pamphlet. The mine is transported plugged and is fuzed when required. A combined gauge and adjusting tool is supplied for the purpose of obtaining the correct depth of fuze-hole. The depth is adjusted by manipulation of the upper screwed plug in the main detonator socket so that the clearance between the base of the fuze and the upper plug is between .06 and .08 inches.

GERMAN TELLERMINE FUZE T.Mi.Z.35 (Tellerminezünder 35)

(Fig. 2)

The fuze mechanism consists of a striker, with spring under initial compression, held off an igniferous detonator by a steel shearing pin. Two safety devices are included to relieve the shearing pin of the spring pressure, a safety bolt passing through a hole in the stem of the striker and a safety lug engaging the head of the striker.

The brass body of the fuze is screwthreaded externally below the flange for insertion in the cover plate of the Tellermine and is recessed from the base to receive the striker with its guide and the spindle of the safety lug. The recess is designed to permit the guide to move further into the body when the fuze functions. A cylindrical projecting sleeve, screwed into the side of the body, is aligned with a radial channel which intersects the upper part of the striker recess for the insertion of the safety bolt. A stop pin is fitted inside the sleeve at the lower side near the outer end to limit the withdrawal of the safety bolt. A recess formed in the top of the body is connected by a short channel with the interior and accommodates the setting head for the spindle of the safety lug. A stop pin on the top of the body, underneath the igniter top plate, limits the turning movement of the setting head.

The striker assembly consists of the striker, spring, shearing pin and striker guide. A transverse hole is drilled in the cylindrical stem of the striker to receive the safety bolt. A collar formed near the head supports one end of the spring and is stepped to engage the safety lug. A radial recess in the collar coincides with a channel in the guide for the insertion of the steel shearing pin. A vertical recess is also formed in the periphery of the collar, this is probably intended for the escape of air as the striker is forced downwards. The striker guide protrudes from the base of the body and is retained in the body recess by a screwed collar, which does not prevent it moving inwards. The collar screws into the body recess and has an internal flange which engages a step formed round the exterior of the guide. The guide is in the form of an inverted cup with an internal diameter to suit the collar formed

on the striker. The closed end of the cup engages the upper end of the spring and has a hole at the centre for the striker stem. A hole is formed in the side of the spring case portion of the guide

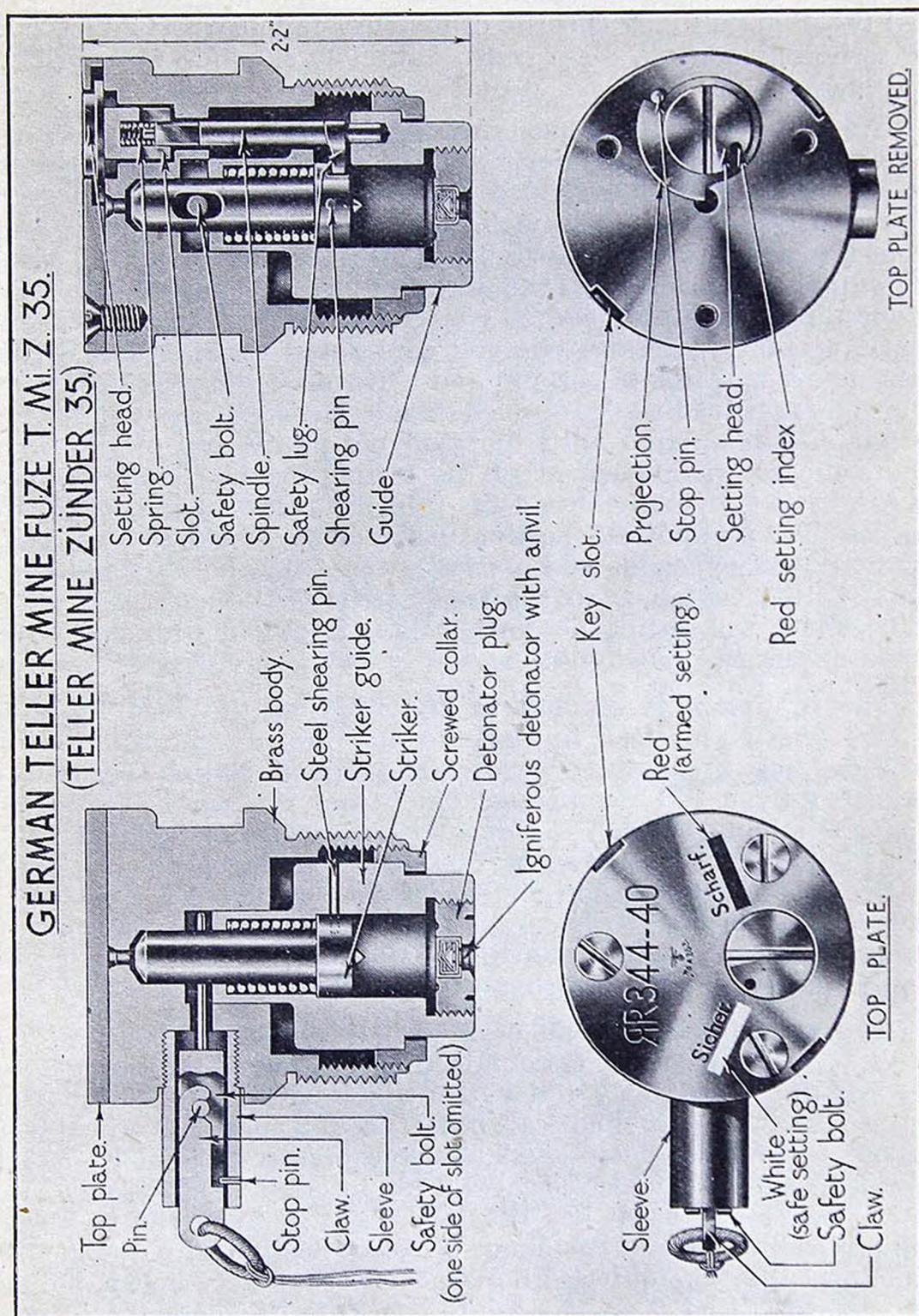

FIG. 2

for the escape of air pressure and a slot is provided through which the safety lug protrudes to engage the step in the striker head. The guide is closed at the base by a screwed detonator plug which carries an igniferous detonator. The detonator includes an anvil and the .3 grain filling consists of mercury fulminate 14.2 per cent., potassium chlorate 37.8 per cent., antimony sulphide 41.7 per cent. and glass 6.3 per cent.

The safety lug is formed near the lower end of the spindle which is reduced in diameter and enters a recess formed in the guide. The lug is fan shaped and extends through 130 degrees. The surface of the lug is inclined so that as it is rotated away from the striker (anti-clockwise) the pressure exerted by the spring is gradually transferred to the shearing pin. The spindle has flats formed near the upper end to engage with the setting head and a pintle at the top locates one end of a spiral spring. The setting head has a tool slot in the top and a red spot which is the setting index. A stepped flange formed round the head has a projection which, in conjunction with the stop pin in the top of the body, limits the rotary movement of the setting head. The lower part of the head is cylindrical and fits into the recess in the top of the body. The cylindrical portion is recessed and has two slots, diametrically opposite, which engage the flats on the spindle. A spiral spring contained in the recess permits the spindle to move further into the setting head when it is forced in with the striker guide during the functioning of the fuze.

The top plate is secured to the body of the fuze by three screws and is marked to indicate the armed and safe setting positions for the setting head. The armed setting position is indicated by a red rectangular patch and the word "Scharf". The safe setting position is indicated by a white rectangular patch and the word "Sicher." Rotation of the setting head, clockwise, so that the red index spot is moved from "Sicher" to "Scharf" causes the safety lug to disengage from the step in the collar on the striker. Two recesses in the edge of the top plate correspond with similar recesses in the fuze body to form key slots.

The safety bolt consists of a slotted cylindrical body with a hook attachment which is contained in the sleeve projecting from the side of the fuze body and a stem which passes through a hole in the striker. The cylindrical body portion has a vertical slot extending from its outer end along the greater part of its length to receive the claw which engages a pin inserted transversely in the slot. The claw is a flat key with a hook at its inner end to engage the pin in the slot and has about 5 feet of flexible wire attached at its outer end. The outward movement of the safety bolt is limited by the end of the slot coming into contact with the stop pin near the outer end of the sleeve.

Action

After the mine has been laid the setting head is turned so that the red spot on the setting head is aligned with the red rectangular patch marked "Scharf," thus disengaging the safety lug from the striker, and the safety bolt is withdrawn from the striker by pulling the claw wire. When the bolt has been withdrawn to the extent permitted by the stop pin in the sleeve the claw becomes detached from the bolt and the striker is then supported only by the shearing pin. When pressure is applied to the fuze, or the cover plate of the mine, the spring supporting the cover plate is compressed and the fuze is forced downwards. The striker guide, supported by the mine beneath, enters further into the fuze body. The movement of the striker guide, relative to the striker, breaks the shearing pin and the striker is driven down by its spring and fires the igniferous detonator. The flash produced passes through the channel in the closing discs of the detonator socket of the mine and initiates the main detonator which with the amplifying effect of the exploder pellet detonates the bursting charge.

The load required to actuate the fuze in the mine has been found by experiment to be approximately 350 lb. Five fuzes were used in the trial and the required loads were found to vary between 342 lb. and 357 lb. With the fuze removed from the mine, so that the resistance of the spring under the cover plate is excluded and only the shearing pin has to be severed, the load required is approximately 231 lb. The loads required with ten fuzes at a trial varied between 225 lb. and 239 lb.

GERMAN PULL IGNITER Z.Z.35 (Zugzünder 35)

(Fig. 3)

The brass igniter, fitted with a detonator of the No. 8 type, is used with a pull wire in the side and base of the Tellermine and in conjunction with trip wires to function the S-mine. Booby traps operated by pull wires may also be fitted with this igniter. The mechanism consists of a striker, with spring under initial compression, held off an igniferous detonator by supporting pins which are held in position by a guide until the pull is applied. The body of the igniter is a cylindrical casing fitted with a projecting sleeve at the outer end and screwthreaded internally at the inner end for the insertion of the guide. The sleeve is perforated to receive the safety pin which passes through a hole in the release cylinder. The outer end of the retaining spring bears against a flange on the inner end of the sleeve.

The release cylinder extends through the body and the guide and protrudes from the outer end of the body where an eyelet is formed for the attachment of the pull wire and a hole for the safety pin. A collar is formed round the cylinder to support the

inner end of the spiral retaining spring. The cylinder is recessed from its inner end through the greater part of its length to accommodate the striker and striker spring. Holes are formed in the cylinder wall, where it fits in the guide, to receive the pins supporting the striker.

The striker is contained inside the inner end of the release

GERMAN PULL IGNITER Z.Z.35 (Zugzünder 35)

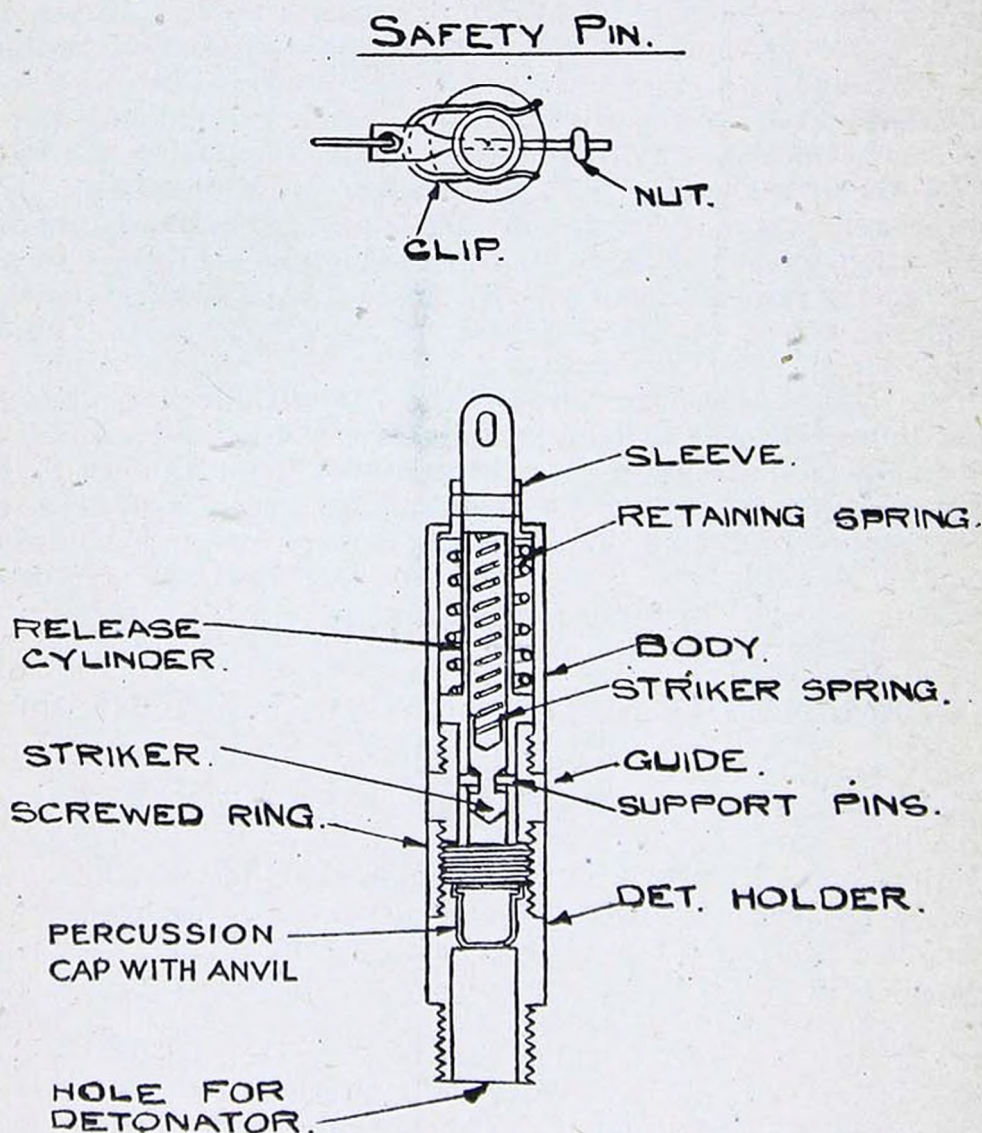

FIG. 8

cylinder and consists of a cylindrical body with pointed head. A recess is formed in its outer end to seat one end of the striker spring and a groove round the body to engage the supporting pins. The outer side of the groove is inclined outwards to facilitate the ejection of the pins in functioning.

The striker spring is assembled under compression in the release

cylinder between the striker and the closed end of the cylinder recess.

The safety pin is fitted with a finger ring and is inserted through the sleeve and release cylinder where it is retained by a nut screwed on at the end and a spring clip which clips round the sleeve.

The guide is screwed into the inner end of the body and is also threaded to receive the screwed ring for the attachment of the detonator holder. The channel through the guide is a close fit round the inner end of the release cylinder so that the pins supporting the striker are held in engagement with the groove in the striker.

The screwed ring is screwed on the inner end of the guide for the attachment of the detonator holder and acts as a distance piece between the striker head and the percussion cap.

The detonator holder carries a percussion cap and is bored to receive a detonator of the No. 8 type. The exterior of the holder is screwthreaded for insertion in the store with which the igniter is used.

Action

With the safety pin removed the striker is held, against the pressure of its spring, only by the support pins. When the pull wire is pulled the retaining spring is compressed and the cylinder is drawn outwards. After moving about .2 inches the holes containing the support pins in the cylinder wall emerge from the guide and the pins are ejected by the inclined side of the striker groove under the pressure of the striker spring. The striker is then driven on to the percussion cap by its spring and the flash passes into the detonator inserted in the open end of the holder.

GERMAN MECHANICAL TIME FUZE S/30 (Zt. Z.S/30)

(Figs. 4, 5 and 6)

This is the standard German heavy A.A. fuze. It weighs 13 oz. 12 dr.

The main points of difference between this mechanical time fuze with a clock spring drive and the British No. 207 fuze are given in Pamphlet No. 6, which also includes a drawing showing the main components. The details of the mechanism, shown in Figs. 5 and 6, are as follows:—

The mechanism is assembled in a cylindrical unit of super-imposed brass plates and consists of:—

The centre arbor in the form of a tubular shaft with a pinion at its base end. The upper end of the shaft is open and has two slots formed in the wall, which engage the hand centre. An external projection is formed near the base of the shaft to engage one end of the main spring.

The main spring coiled under tension in a brass barrel or casing. One end of the spring engages the centre arbor whilst the other

GERMAN MECHANICAL TIME FUZE, S/30.

(Zt. Z. S/30.)



FIG. 4

GERMAN MECHANICAL TIME FUZE. S/30

(Zt. Z. S/30.)

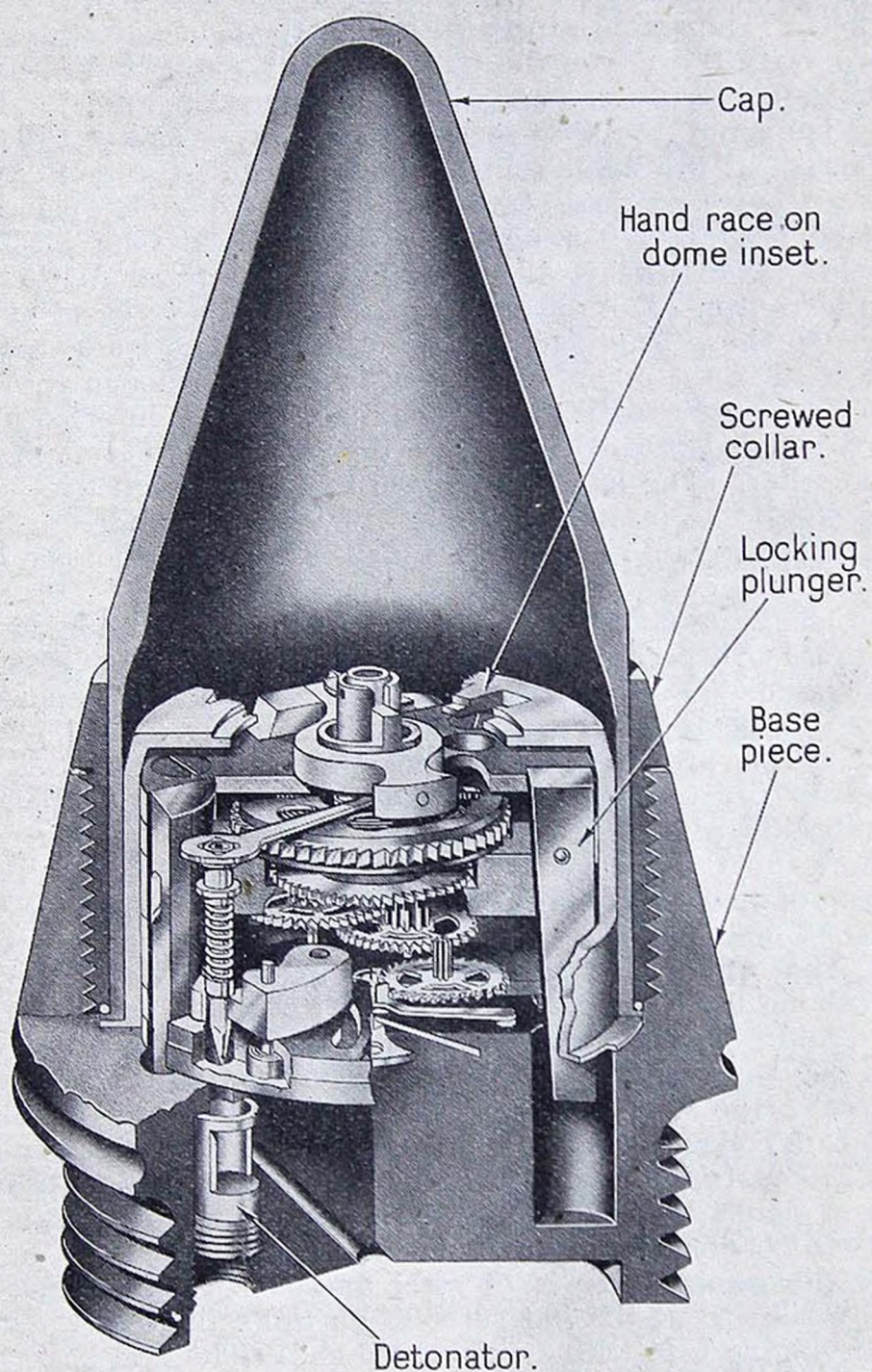

FIG. 5

engages the casing. The cylindrical casing fits around the lower end of the centre arbor and has ratchet teeth formed around its periphery. These teeth are engaged by a ratchet and provide the means of revolving the case to wind the spring during the assembly of the fuze.

An escapement engaging the base pinion of the central arbor comprising two spurs with pinions and a spur with the escapement wheel. The ratchet teeth of the escapement wheel are engaged by two vertical arms on the pallet, which is weighted at each end and controlled by a straight adjustable hair spring.

The hand assembly carried at the upper end of the centre arbor consists of the hand centre, the hand and the hand spring. The hand centre consists of a short hollow cylinder, open at the base, fitted with two rectangular brass arms carrying a ring near the head. The hand is of aluminium and is fixed to the ring of the hand centre. The outer end of the hand is recessed at one side to engage the spring catch on the trigger. The spiral hand spring is inserted in the open base end of hollow cylinder in the hand centre and is compressed when the hand assembly is inserted in the centre arbor and depressed to engage the rectangular arms in the slots of the arbor. The hand is retained in this position by the hand race on the dome inset and is thus prevented from rising until it has been rotated into alignment with the cut away portion of the hand race.

The brass trigger, holding the outer end of the hand, consists of a brass arm pivoted at one end and stepped at the other to engage the hand. The step is slightly undercut. A small hole in the outer side of the trigger contains a minute spring loaded plunger. The plunger is pressed into the hole by contact with the side of the slot in the top plate in which the trigger is located. A safety bridge, fitted across the slot, has a projection which overlaps the hand and thus prevents the hand rising until it has been rotated clear of the projection. This movement takes approximately one second of time.

The striker, located near the circumference of the cylindrical mechanism unit, is a steel spindle with a cam collar near the lower end and a pyramid shaped point at the base. Two flats are formed at the upper end of the spindle to engage with corresponding surfaces in the safety lever. The striker is held off the detonator by its cam collar resting on a conical headed steel pillar and on a step in the centrifugal safety catch. The spiral striker spring fits over the spindle and is compressed between the cam collar and the sleeve portion of the safety lever.

The safety lever is of steel and consists of a sleeve, shaped internally to fit the flat surfaces on the spindle of the striker, and carrying an arm with an upturned end. The arm bears against the underside of the top plate and the upturned end is held adjacent to the centre arbor by the ring of the hand centre. A curved slot

is cut in the top plate to permit a swinging movement of the arm.

The centrifugal safety catch pivoted in the lower plate is of brass and has a step formed in one side to support the cam collar on the striker. The pivot pin is slotted to engage a coil spring which keeps the catch in the safe position. The swinging movement of the catch is limited by a steel pin fixed in the catch near

GERMAN MECHANICAL TIME FUZE S/30.

(Zt. Z. S/30.)

DIAGRAMMATIC ARRANGEMENT OF MECHANISM.

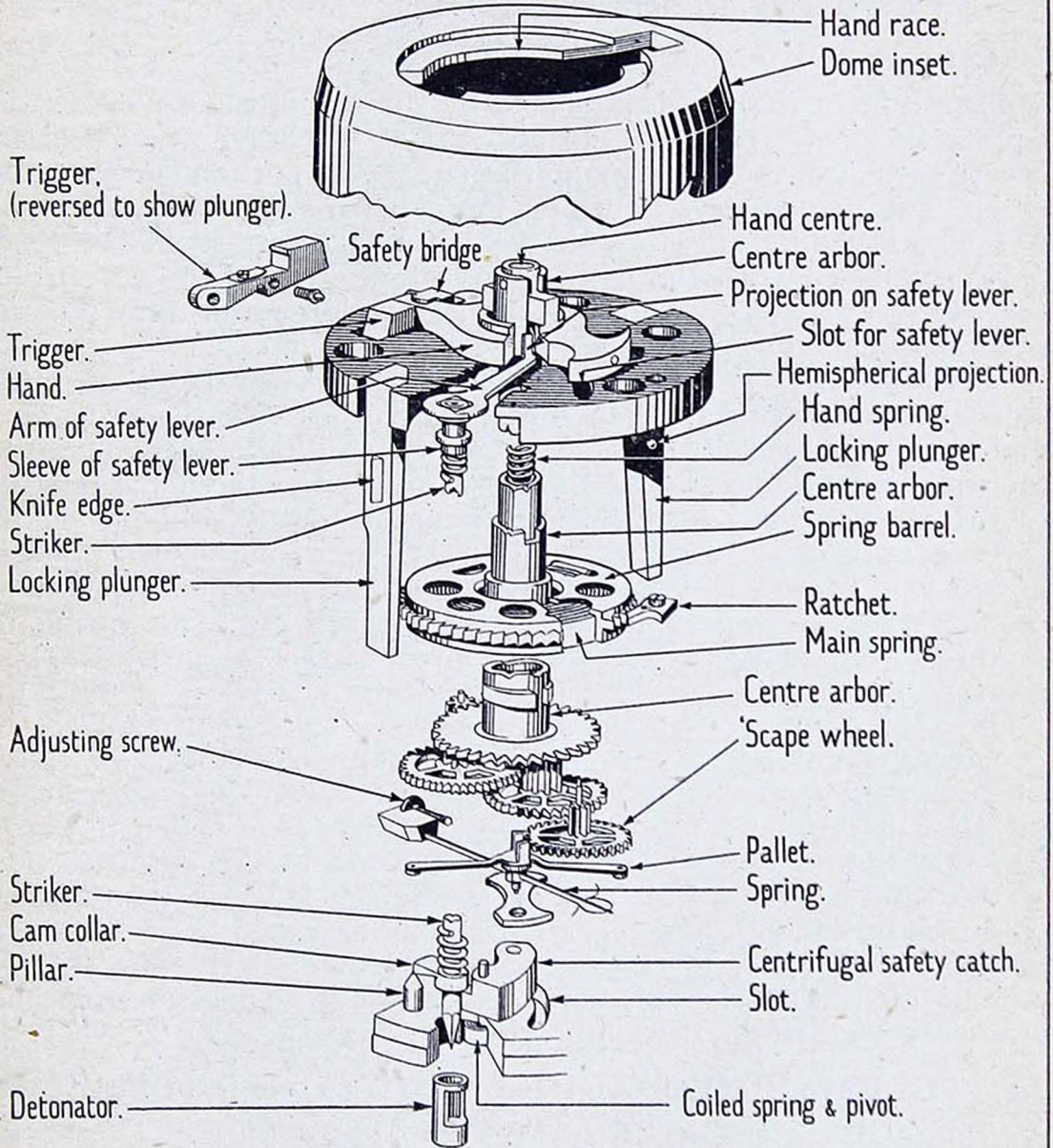

FIG. 6

the free end and a curved slot, through which the pin moves, in the lower plate.

Two tapered steel locking plungers are carried in vertical slots formed down the side of the cylindrical mechanism unit. The slots are diametrically opposed and each has a hemispherical recess in one side to receive a corresponding projection on the side of the tapered plunger. The plungers are comparatively weighty and consist of steel strips tapering towards the base on the inner side. On the outer side of each, approximately at the centre, a projecting vertical knife edge is formed. The plungers project below the base of the mechanism unit into recesses formed in the platform of the fuze body. The recesses are sufficiently deep to permit the plungers to set back during acceleration.

Action

The time of running is governed by the size of the arc extending counter-clockwise between the position of the hand when held by the trigger and the position of the cut away portion of the hand race. The fuze is set by turning the cap with the aid of a setting device. The dome inset, with the hand race formed in its upper part, is rotated with the cap to the set position. The turning of the cap is retarded by the waved wire tension spring between the screwed collar and the flange at the base of the cap.

On acceleration the two tapered plungers set back into the recesses in the platform. As their wider portions with the projecting knife edge move back through the slots, the knife edges cut into the wall of the dome and thus prevent rotation of the dome relative to the mechanism. At the same time the trigger, hinging on its pivot, sets back and releases the hand. The spring loaded plunger in the side of the trigger then emerges and prevents rebound of the trigger. The release of the hand enables the main spring to rotate the centre arbor, under the control of the escapement. The rotating hand, moving clear of the safety bridge, is pressed up against the hand race by the spiral spring in the hand centre.

During flight, the safety catch is swung clear of the striker, which is then supported only by the pillar. When the hand reaches the part of the hand race which is cut away, it is forced upwards and the ring on the hand centre moves clear of the upturned end of the safety lever. The end of the safety lever is then swung outwards by centrifugal force. The striker is turned by the lever so that the cam collar loses the support of the pillar. The spring, bearing on the cam collar, then drives the striker away from the safety lever on to the detonator.

GERMAN MECHANICAL TIME FUZE S/30 Fg¹

(Zt.Z.S/30 Fg¹)

(Figs. 7, 8 and 9)

The fuze (weight 15 oz. 12 dr.) is used in 8.8 cm. and 10.5 cm.

GERMAN MECHANICAL TIME FUZE, S/30 Fg1.

(Zt.Z. S/30 Fg1.)



FIG. 7

H.E. A.A. shell and resembles the Zt.Z.S/30 in external appearance but differs in the mechanism in which the motive power is derived from centrifugal force instead of from a clock spring. The type is identified by the stamping "Zt.Z.S/30 Fg¹" around the side of the body above the flange. The fuze is igniferous and has a maximum time of running of 30 seconds. The mechanism governing the setting is designed to prevent the fuze functioning at settings shorter than approximately 1 second.

The fuze consists of the base piece or body, the cap, the screwed collar and the mechanism.

The base piece is screwthreaded externally below the flange for insertion in the shell and has a large cylindrical recess in which the mechanism is located. The recess is screwthreaded internally for the assembly of the screwed collar retaining the cap and has a flash hole and a number of holes for the retaining bolts of the mechanism in the base.

The cap is cone shaped with a rounded head and on a shoulder formed in its base ring carries the setting pin and the hammer spring. The steel pin is let into the base and engages an upturned forked strip on the setting disc of the mechanism. The hammer spring is secured to the shoulder in the base by two screws at one end and extends diametrically across the base of the cap. The unsupported end is forked to fit round the setting pin and is fitted with three brass hammer pieces on the underside. The two larger of these pieces are fitted one on each projection of the fork, i.e. each side of the setting pin, and the third smaller piece is nearer the centre of the spring. These positions coincide respectively with the projections on the fork end of the strip on the setting disc and a locking pin carried in the setting disc.

The screwed collar fitting over the lower portion of the cap has an internal rib held, with a waved wire tensioning spring, in a groove between the cap and its base ring.

The mechanism is assembled in a cylindrical unit of superimposed plates of brass and aluminium and consists of:—

A central shaft with a spur near the lower end and a pinion at the base. The upper part of the shaft is reduced in diameter to receive the bush carrying the setting and safety discs and is screwthreaded to receive the tensioning and locking nuts. The sloping shoulder formed by the reduction of the diameter is serrated to engage with similar serrations on the bush so that the bush is locked to the shaft. A stop pin on the pinion limits the rotational movement of the shaft.

Two weighted centrifugal toothed segments pivoted near the circumference of a circular plate and each enmeshed with a spur. The spurs carry pinions at their base ends which are enmeshed with the spur on the central shaft. The plate carrying the centrifugal segments is cut away to provide clearance for the movement of the

GERMAN MECHANICAL TIME FUZE, S/30 Fg 1.

(Zt.Z.S/30 Fg 1.)

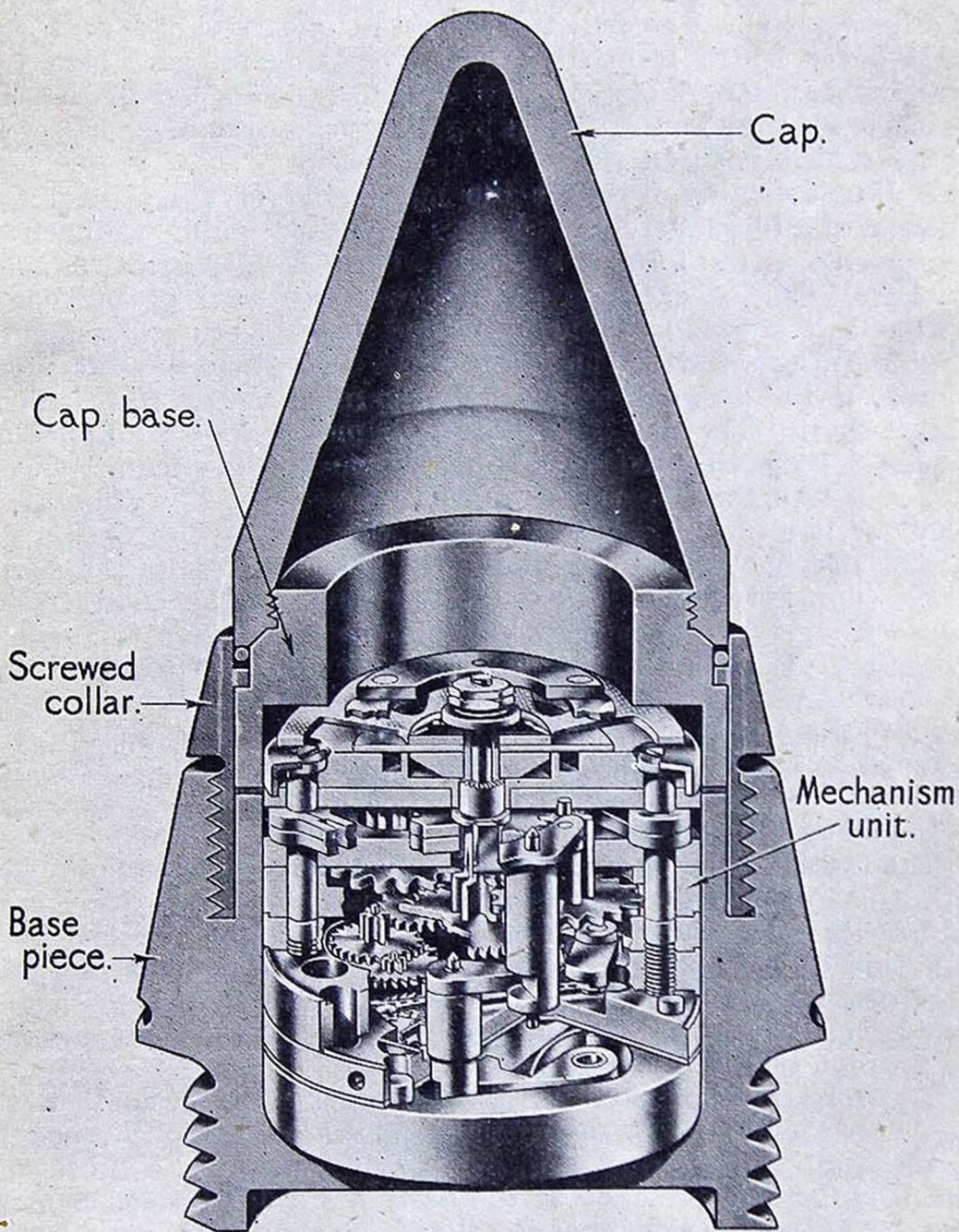

FIG. 8

segments and the recesses thus formed are fitted with a spring strip which imparts the initial movement to the segment.

An escapement engaging the base pinion of the central shaft comprising three spurs with pinions and a spur with the escapement wheel. The wheel is engaged by two vertical arms on the pallet which is weighted at each end and controlled by a straight adjustable hair spring. The pallet is locked at one end by a centrifugal safety lever which is fitted with a weighting pin and held by a retaining spring. A step formed on the pivoted end of the lever is engaged by the end of the spring strip when the lever has swung to the armed position.

A disc assembly fitted at the upper end of the central shaft consists of a bush carrying two discs and a tensioning arrangement. The bush is in the form of a sleeve with a hemispherical flange at the base. The sleeve portion fits over the head of the central shaft and is serrated at the lower end to engage a corresponding shoulder on the shaft. The lower of the two discs, the safety disc, is keyed to the flange of the bush and so must always turn with the central shaft. The disc is smaller in diameter than the upper disc but has a projecting leaf formed at one part of its circumference to close a slot in the upper disc and so prevent the operation of the firing mechanism. The upper disc is the setting disc and is held on the sleeve of the bush under the tension of a saucer-shaped spring compressed and locked by two nuts on the central shaft. Before firing, the setting disc can be rotated relative to the bush and safety disc but after firing the discs are locked together when the locking pin carried in the setting disc is driven into the safety disc by the hammer spring. The setting disc has an upturned forked strip which engages the setting pin in the cap and, diametrically opposite, a curved slot which when aligned with a projection on the firing arm releases the firing mechanism.

The firing arm, operated by centrifugal force, consists of a shaft with a flat formed by a recess near its lower end and with a cross-head at its upper end. The cross-head has a weight attached to the underside at the end of one arm and a vertical strip projecting upwards from the end of the other arm. The strip bears against the edge of the setting disc and the lower end of the shaft obstructs the rotation of the retaining bolt.

The retaining bolt securing the retaining catch in contact with the detonator pellet is a centrifugal device held in the safe position by the shaft of the firing arm. The bolt consists of a short shaft with a radial arm attached at the head and a flat formed near the base. The radial arm engages the firing arm and provides the weight for centrifugal action whilst the flat engages the end of the flat side on the retaining catch.

The retaining catch in the form of a hook is pivoted at one end and hooked to engage the detonator pellet at the other.

The detonator pellet contained in a transverse rectangular slot

GERMAN MECHANICAL TIME FUZE S/30 Fg 1.

DIAGRAMMATIC ARRANGEMENT OF MECHANISM.

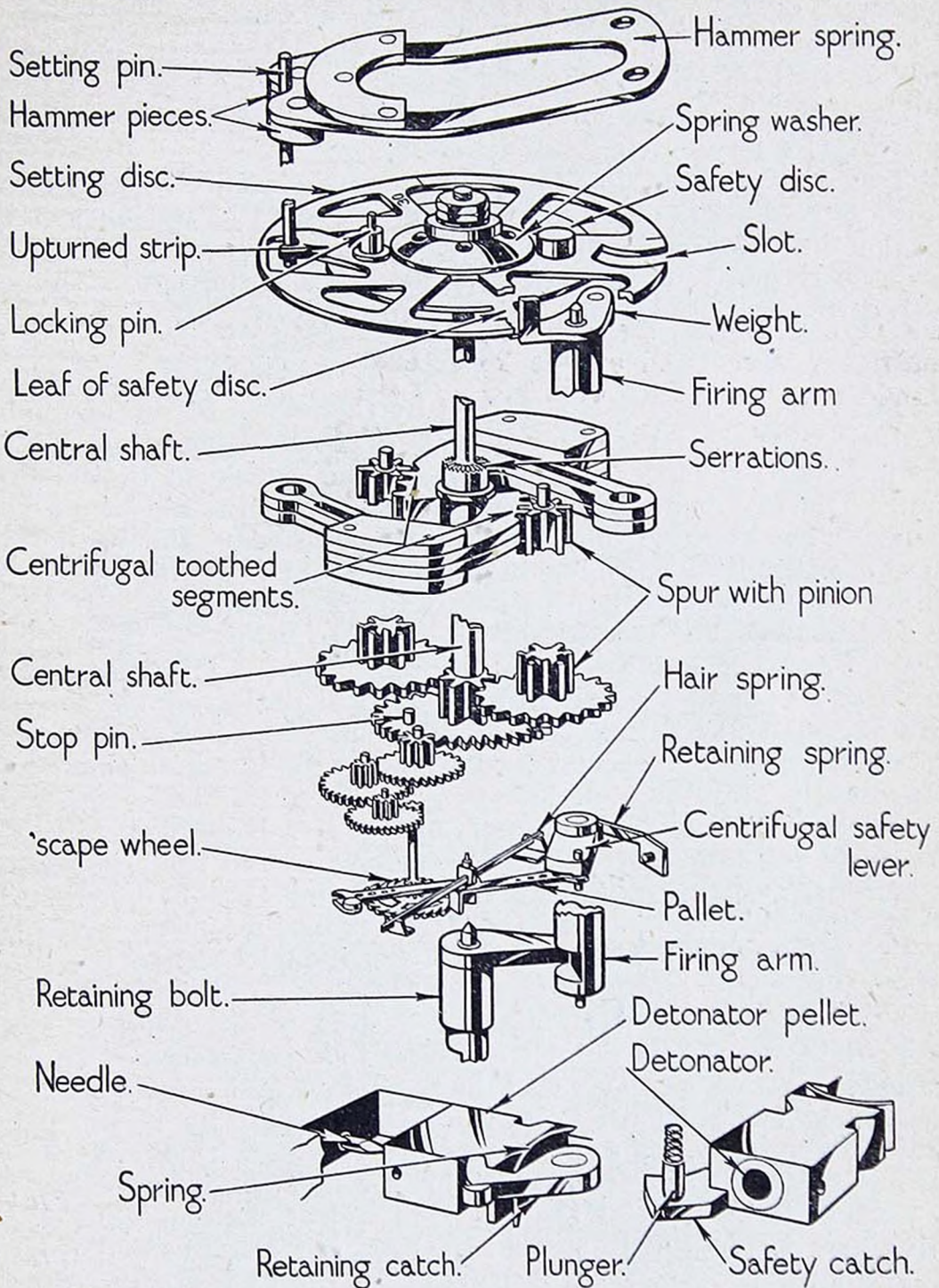

FIG. 9

in the base of the mechanism unit is of brass and is rectangular in shape. A notch is cut in the two vertical sides and the detonator is contained in a recess at the inner end. A flash channel from this recess emerges at the underside of the pellet. A curved spring strip between the outer end of the pellet and one end of the pellet slot is held under compression by the retaining catch, engaging in one of the side recesses of the pellet. The needle is fixed in the opposite end of the slot. The detonator pellet is also held by a centrifugal safety catch.

The safety catch, located in a channel cut in the side of the pellet slot, consists of a flat brass plate shaped at its inner end to engage the front end and one side of the detonator pellet. The catch is retained in the safe position by a spring-loaded plunger with a rounded base which enters a recess in its surface.

Action

The time of running is governed by the size of the arc extending clockwise between the curved slot in the setting disc and the position of the vertical projection on the crosshead of the firing arm. The fuze is set by turning the cap with the aid of a setting device. The rotation of the cap is transmitted to the setting disc by the setting pin engaging in the forked strip of the setting disc whilst the safety disc is held keyed to the stationary bush on the central shaft. The curved slot in the setting disc is thus rotated clear of the projecting leaf on the safety disc. The width of the leaf and its position relative to the vertical projection on the firing arm are so arranged that the leaf still closes the slot at settings up to approximately 1 second and so prevents the fuze functioning dangerously near the gun.

On acceleration the hammer spring sets back flattening permanently the forked strip on the setting disc and thus disengaging it from the setting pin. At the same time the hammer spring strikes the small locking pin and drives it into an unsupported part of the safety disc. The setting disc is then locked to the safety disc. When the safety lever has been thrown clear of the pellet by centrifugal force it is retained in this position by its spring engaging a step at its outer end. The toothed segments, operated initially by the springs fitted in the plate and subsequently by centrifugal force, then revolve the central shaft by means of the spurs and pinions. The disc assembly rotates with the shaft, the rate of rotation being controlled by the escapement. Whilst this movement is in progress the weighted end of the crosshead on the firing arm is tending to swing outwards but is prevented from so doing by the upturned end bearing against the edge of the rotating setting disc. Also, the spring loaded plunger of the safety catch is eased from the catch by deceleration and the catch is thrown clear of the detonator pellet by centrifugal force.

When the slot in the setting disc reaches alignment with the

GERMAN FUZE A.Z. 38.

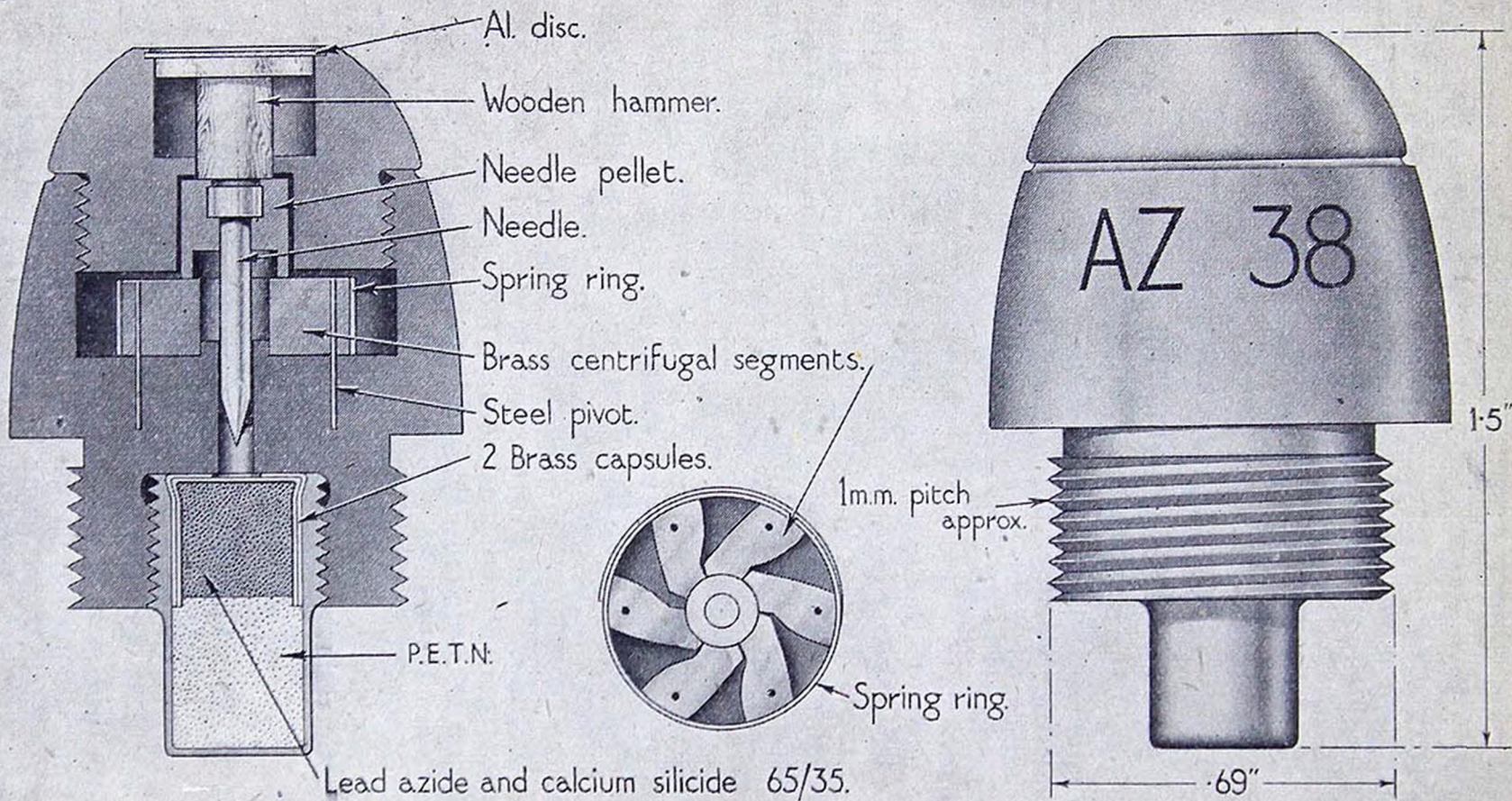

FIG. 10

upturned end of the crosshead the firing arm is revolved to the extent permitted by the slot and the recess cut in its lower part is turned to provide clearance for the arm of the retaining bolt. The arm then moves outwards and the flat surface on its shaft is rotated through a right angle so that it clears the side and the curved end of the retaining catch. The catch is then thrown clear of the detonator pellet which is driven on the needle by its spring.

GERMAN FUZE A.Z.38

(Fig. 10)

The fuze is of the direct action type and is used in conjunction with a gaine in hollow charge shell. It weighs $14\frac{1}{2}$ drams. The portion of the fuze protruding from the impact cap of the shell is dome shaped with a flat circular disc of aluminium at the top. The marking "A.Z.38" is stamped in the side of the fuze above the flange.

The body of the fuze is screwthreaded externally to .69 inch gauge with a pitch of approximately 1 mm. for insertion in the shell. A recess formed in the underside is screwthreaded to receive the magazine which contains a 6.2 grain filling of P.E.T.N. under a 5.9 grain detonator of lead azide/calcium silicide 65/35. The upper part of the body is recessed to accommodate six pivoted centrifugal segments and threaded internally to receive the aluminium head of the fuze. A central channel is formed between the upper and lower recess for the needle.

The steel needle is carried in an aluminium pellet supported by the centrifugal segments which are retained in the supporting position by an expanding spring ring.

The aluminium head of the fuze is recessed in the underside to accommodate the needle pellet and recessed at the nose to take the hammer which passes through a hole in the diaphragm between the recesses. The hammer is of wood and rests on the head of the needle pellet. The recess containing the hammer is closed at the nose against air pressure by an aluminium disc sealed with a fillet of synthetic resin.

Action

During flight the coil of the expanding spring ring is enlarged and the segments rotated clear of the needle pellet by centrifugal force. The needle is then held off the detonator by the creep action resulting from deceleration. On impact the hammer and needle are driven in and the detonator is pierced. The impulse set up by the detonation is communicated through the aluminium tube in the shell to the gaine in the base of the shell cavity. The construction of the detonator in the gaine is such that it could be initiated either by a flash or a pressure pulse.

GERMAN FUZE FOR 37cm. HE. SHELL.

(37cm. Kpf. Z. Zerl. P.)

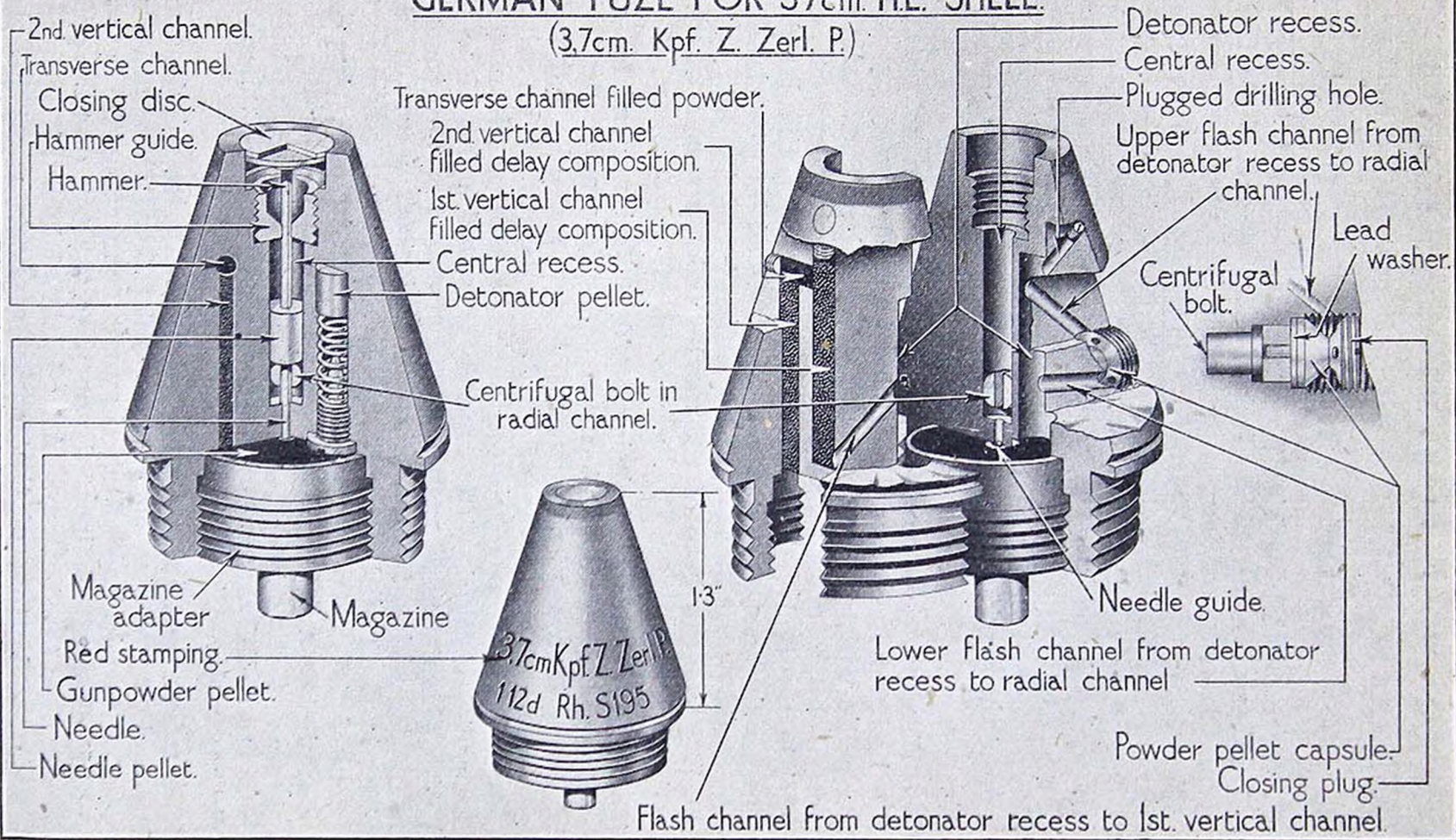

FIG. 11

GERMAN NOSE FUZE WITH SELF-DESTROYING ARRANGEMENT FOR 3.7 cm. H.E. SHELL

(3.7 cm. Kpf. Z. Zerl. P.)

(Fig. 11)

The fuze, which weighs 2 oz. 0 $\frac{3}{4}$ dr., is used in the 3.7 cm. Pak (anti-tank gun) H.E./Tracer shell described in Pamphlet No. 6 and is of aluminium alloy with a body tapering towards the flat topped nose. The tip of the fuze is red and the stamping, "3.7 cm. Kpf. Z. Zerl. P." on the side of the body, is also coloured red. The fuze is of the direct action type and includes a safety device which is released by the disintegration of a pellet of gunpowder. The detonator which ignites the powder pellet also ignites a delay composition which connects with the magazine of the fuze and provides a self-destroying action when direct action does not occur.

The direct action mechanism is contained in a central recess in the body and consists of an aluminium hammer supported by a steel pellet which is integral with the needle. The needle pellet is supported by a centrifugal bolt which protrudes from a radial channel in the body. The hammer consists of a circular disc with a stem which passes through a guide screwed into the body recess. The recess is closed at the top by a thin brass disc and has a hole at the base for the stem of the needle which enters a guide in the magazine adapter.

The brass centrifugal bolt is slotted at its inner end to fit round the stem of the needle and has a collar formed round its centre which limits its inward movement. A stem formed on its outer end bears against a pellet of gunpowder contained in an aluminium perforated capsule attached to the inner side of the closing plug of the radial channel. The capsule is cylindrical with a concave wall with perforations equally spaced around it. The inner end of the capsule, which bears against a lead washer supported by a shoulder in the radial channel, has a hole in the centre to receive the stem of the centrifugal bolt. The screwed closing plug carrying the capsule has a lightly closed vent at its centre for the escape of pressure when the powder is ignited. Two inclined flash channels connect the radial channel with a recess containing a detonator and needle assembly.

The recess containing the detonator with its spiral supporting spring and screwed needle is displaced from the centre of the fuze. The two inclined flash channels connecting the recess with the radial channel are located one near the top of the recess and the other near the bottom. An additional inclined flash channel, also near the bottom of the recess, connects with the channels containing the delay composition for the self-destroying action.

The delay composition for the self-destroying action is con-

GERMAN GAINE N° 40.
(Zdlg. 40.)

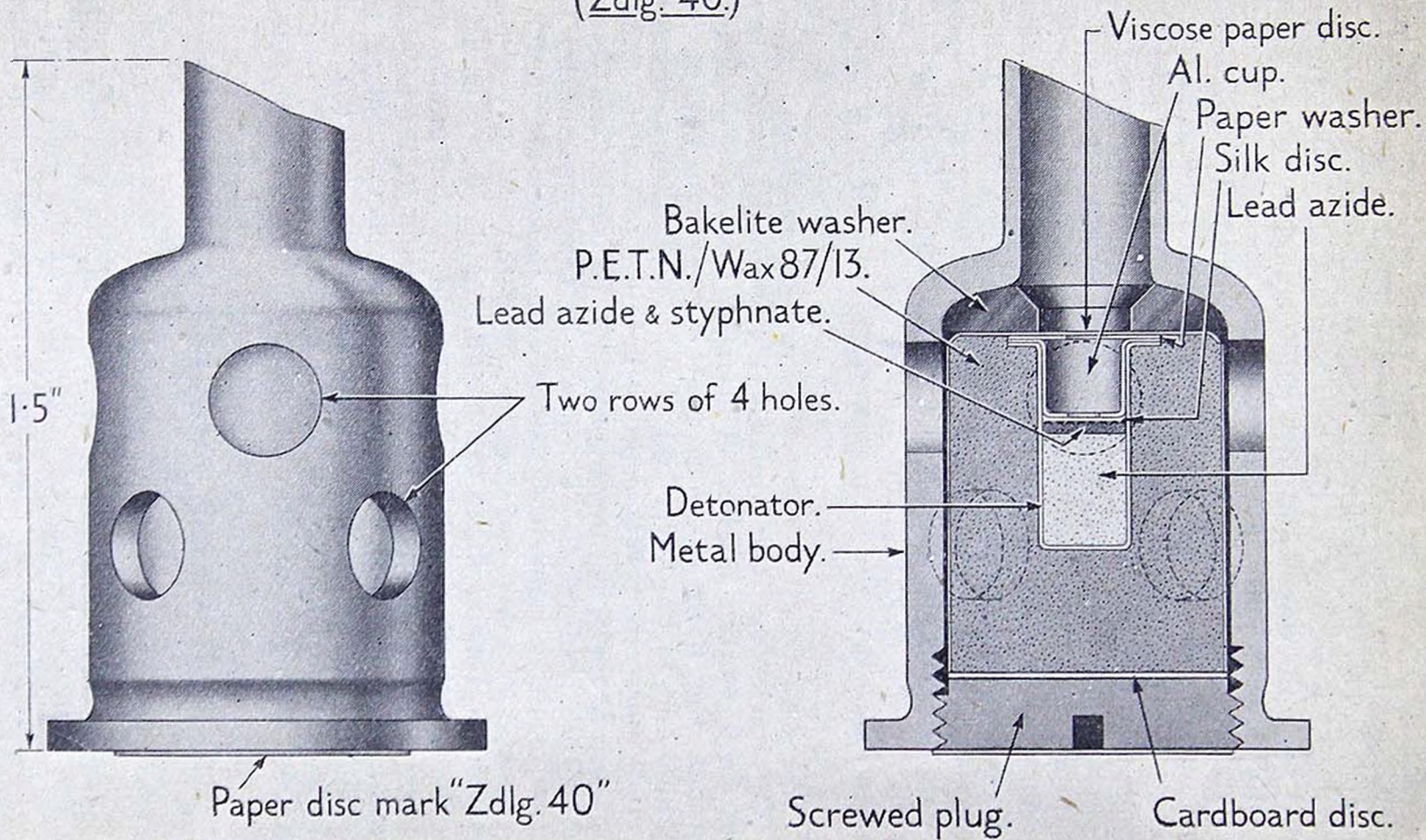

Fig. 12
27

tained in two vertical channels with a transverse connecting channel. The flash channel from the detonator recess leads into the closed lower end of the first vertical channel. This channel is filled from the upper end with delay composition and closed at the top by a plug which is machined to correspond with the tapering body of the fuze. Near the top of the channel a transverse channel containing pressed gunpowder leads into the upper end of the second vertical channel which also contains delay composition and is open at the base where it is in contact with a circular disc of pressed gunpowder carried in a recess in the top of the magazine adapter.

The magazine adapter screws into the underside of the body and carries a magazine similar to that of the A.Z.39, as described in Pamphlet No. 4. The circular recess in the top of the adapter has a cylindrical projection in the centre which is drilled to form a guide for the needle. The pressed pellet of gunpowder contained in the recess is in the form of a washer to fit over the needle guide.

Action

On acceleration the igniferous detonator in the displaced recess sets back on the needle. The flash from the detonator passes through the flash channels to the powder pellet in the radial channel and to the lower end of the delay filling in the first of the vertical channels. When the pellet in the radial channel disintegrates the bolt is thrown outwards by centrifugal force leaving the needle held off the detonator in the magazine by the creep action resulting from deceleration. On impact the needle is driven in by the hammer and pierces the detonator in the top of the magazine. During flight the burning of the delay composition in the first vertical channel is transmitted by the gunpowder in the transverse channel to the delay composition in the second vertical channel. When direct action does not occur before the composition burns to the base of the second channel the disc of gunpowder confined in the top of the magazine adapter is ignited and explodes and thus initiates the detonation of the magazine.

GERMAN GAINE, MODEL 40 (Zundladung 40)

(Fig. 12)

The gaine is used in conjunction with the A.Z.38 fuze in hollow charge shell and is situated in the base of the shell cavity.

The metal body of the gaine is cylindrical with a flange at the base and a rounded top on which a short tubular neck is formed. The neck fits into the lower end of the central tube in the shell and has a broken irregular top. Two rows of holes, 4 in a row, are formed around the body and an internal screwthread is formed at

the base to receive the screwed closing plug. A circular paper label on the base of the gaine is marked "Zdlg.40".

The interior of the rounded head, above the filling, is occupied by a suitably shaped washer of moulded bakelite. The filling consists of 78.5 grains of P.E.T.N./wax 87/13 coloured pink. A cardboard disc is inserted beneath the filling and the top is covered by a transparent disc of viscose paper.

The detonator is fitted in a cavity formed in the top of the filling and consists of a flanged cylindrical shell containing 4.3 grains of lead azide topped with a thin layer of unpressed lead styphnate. The weight of the lead styphnate is .2 grains. A disc of silk fabric of open weave is inserted above the lead styphnate and the mouth of the detonator is closed by a flanged aluminium cup. The cup has a central hole in the base.

Action

The detonation of the gaine is brought about by the initiation of its detonator when the fuze functions. The thin layer of unpressed lead styphnate is intended to pick up from flash, but this may be a precaution only and does not exclude the possibility of the gaine detonator being initiated by pressure through the central tube in the shell when the fuze detonates.

GERMAN 5 cm. Kw.K, CARTRIDGE, Q.F., A.P.C.

(5 cm. Kw.K Pzgr. Patr.)

(Fig. 13)

This fixed Q.F. round is fired from the 5 cm. tank gun (short) (5 cm. Kw.K). The shell is fitted with a penetrative cap in the form of a cone with the apex cut away. The nose of the cap is shaped to form a point. The shell with its cap is painted black and stencilled in red. The cartridge case has the model number "6317 St" and the designation of the equipment, "5 cm. Kw.K", stamped in the base. The following markings relating to the equipment and the weight, nature and size of the propellant charge are stencilled on the side of the case in black:—"5 cm. Kw.K 499 g. Digl.R.P. Go. 5 (200 2/1)". The marking "P.T. + 25°C.", indicating a charge weight for a normal charge temperature of 25° Centigrade, is in red near the base of the case. The overall length of the round is approximately 16.8 inches and the weight 7 lb. 10 oz.

The complete round consists of the following components:—

Armour-piercing shell fitted with penetrative cap, and filled P.E.T.N./wax.

Base fuze, 5103* with tracer.

Case model, 6317 St.

Propellant charge of double base composition with igniter.

Primer, electric C/22.

Shell

The capped shell is fitted with an iron driving band and has two cannellures near the base for the attachment of the case. The small

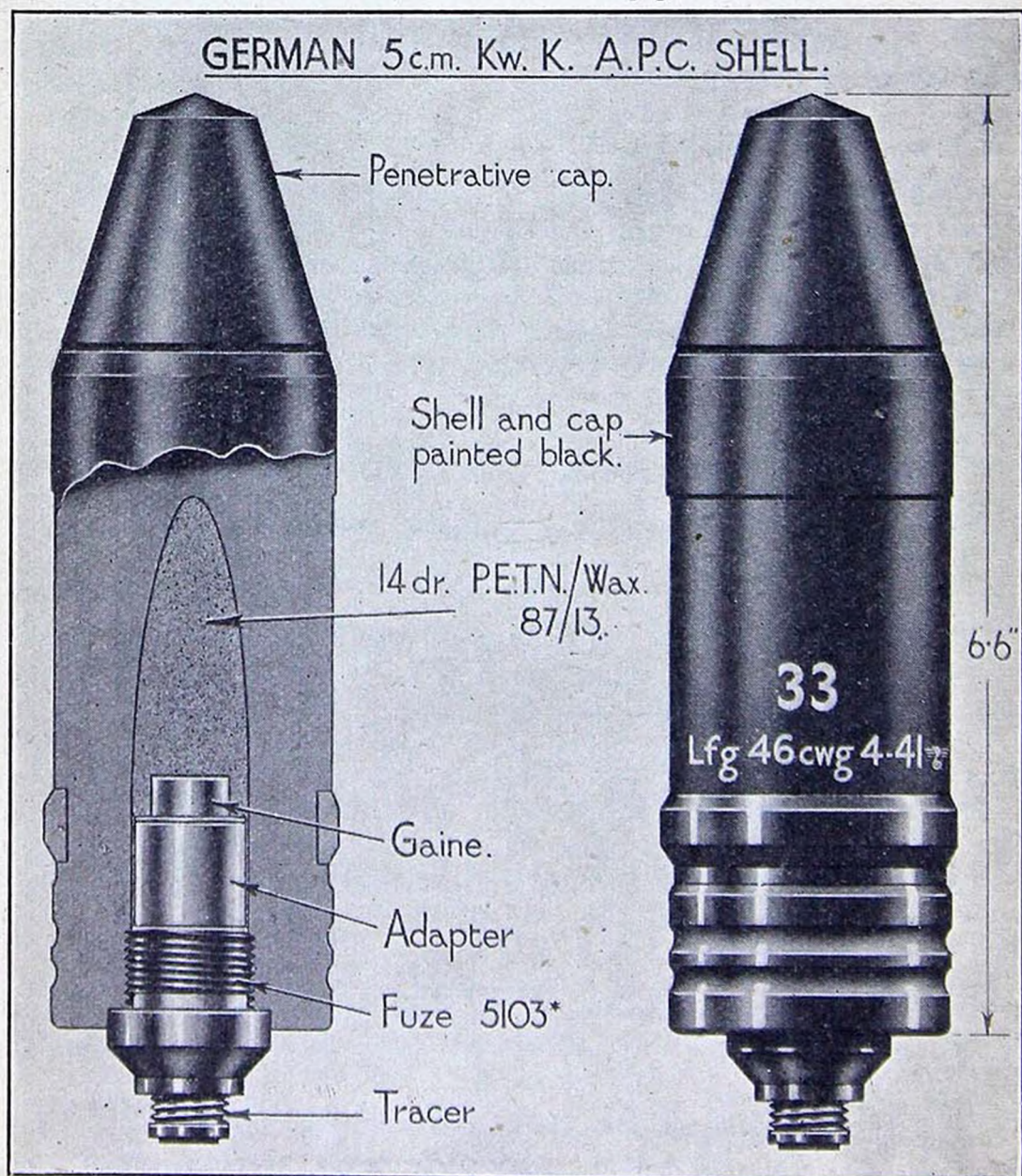

FIG. 13

cavity for the bursting charge is closed at the base by the fuze. The weight of the empty shell is 4 lb. 3 oz. 13 dr.

The bursting charge, which is 50 per cent. larger than that in the A.P. shell, consists of 14 dr. of P.E.T.N./wax 87/13 and has a cavity formed at the base to receive the gaine fitment on the fuze. The weight of the shell filled and fuzed is 4 lb. 8 oz. 15 dr.

Base Fuze and Tracer

The base fuze 5103* with its adapter and gaine is the same as that described for the A.P. shell in Pamphlet No. 4, pages 14 and 15. The igniferous detonator composition contains no fulminate but consists of:—53.4 per cent. of potassium chlorate, 34.3 per cent. of antimony sulphide and 12.3 per cent. of calcium silicide and glass (approximately 3 to 1 of silicide). In addition, there is a small layer of gunpowder in the base end of the detonator.

The tracer is screwed into the base of the fuze and is of the normal type consisting of a steel body with a steel liner and closing disc and a celluloid disc at the base. The tracing composition is pressed with a teat-ended drift in one increment of 23 grains and consists of 3.3 per cent. of resinous matter (probably shellac), 47.5 per cent. of barium nitrate, 22 per cent. of magnesium, .5 per cent. of iron and 26.7 per cent. of silicious matter. The priming composition is pressed with a serrated drift in one increment of 20 grains and consists of 66.7 per cent. of barium peroxide, 12.9 per cent. of barium carbonate and 20.4 per cent. of magnesium.

Case

The case is of the necked type and is approximately 11.4 inches in length. As indicated by the letters "St" stamped after the model number in the base, the case is of steel and is coated with brass.

Propellant Charge

The weight of the propellant charge, according to the markings, is 1 lb. 1 oz. 10 dr. and the igniter 5.5 dr. The charge is contained in a bag with an igniter bag formed at the base.

The propellant is in tubular form, the dimensions of the tubes being:—length 7.9 inches, external diameter .08 inches, internal diameter .03 inches. The composition, as found by analysis, is as follows:—

| | |
|---|-----------------|
| Nitrocellulose (Nitrogen content 11.81 per cent.) | 61.75 per cent. |
| Diethylene glycol dinitrate | 26.19 " " |
| Carbamite | 8.09 " " |
| Potassium sulphate | .8 " " |
| Waxy material | 2.9 " " |
| Graphite | .27 " " |

The igniter bag is marked "10 g. NzM NP (1,5/1,5)". The filling consists of pale-grey-green porous cylindrical grains of nitro-cellulose composition. The composition contains 88 per cent. of nitrocellulose (nitrogen content 13.1 per cent.) and includes diphenylamine, carbamate, potassium sulphate and graphite.

Primer

The electric primer C/22 is described in Pamphlet No. 4, page 31. A new feature is the use of a blue insulating material probably consisting of vinyl polymer. Previously a yellow cellulose acetate composition has been used.

GERMAN 7.5 cm. Kw.K CARTRIDGE, Q.F. HOLLOW CHARGE, MODEL 38 (7.5 cm. Gr. Patr. 38 Kw.K) (Fig. 14)

This fixed Q.F. round is fired from the short 7.5 cm. tank gun (7.5 cm. Kw.K) and assault gun (Stu.G. 7.5 cm. K.). The weight of the complete round is approximately 12 lb. 14 oz. and the overall length 18.5 inches. The shell is fitted with a dome-shaped impact cap which carries the small direct action fuze A.Z.38. The cap and shell are painted the normal dark olive green or, in some instances, white. There is no fundamental difference between the shells of these colours. The numeral "95", indicating the nature of filling, is marked on the cap in black. The cartridge case is stamped in the base with the model number 6354 St and the designation of the tank gun "7.5 cm. Kw.K".

The complete round consists of the following components:—

Fuze, A.Z.38.

Shell, model 38, filled cyclonite/wax/T.N.T.

Gaine, model 40.

Case, model 6354 St.

Propellant charge of 355 grams of Nz.R.P. (135.5,5/2).

Primer, electric C/22.

Shell

The weight of the shell, filled and fuzed, is approximately 9 lb. 14 oz. and the overall length, 11.2 inches.

The steel body of the shell is punched and drawn with a solid base and is fitted with a single driving band of the iron copper clad type. A cannellure is formed behind the driving band for the attachment of the case. The cavity for the bursting charge tapers towards the base and is designed for a block filling. An internal screwthread is formed at the forward end of the body to receive the impact cap. The impact cap is of cast iron and is dome-shaped with a flat formed on the top in which a screwthreaded fuze hole is formed. A circumferential shoulder is formed on the inner

GERMAN 7.5cm Kw.k. & Stu.G. 7.5cm. K-Shell Q.F. HOLLOW CHARGE.
 (Granate 38.)

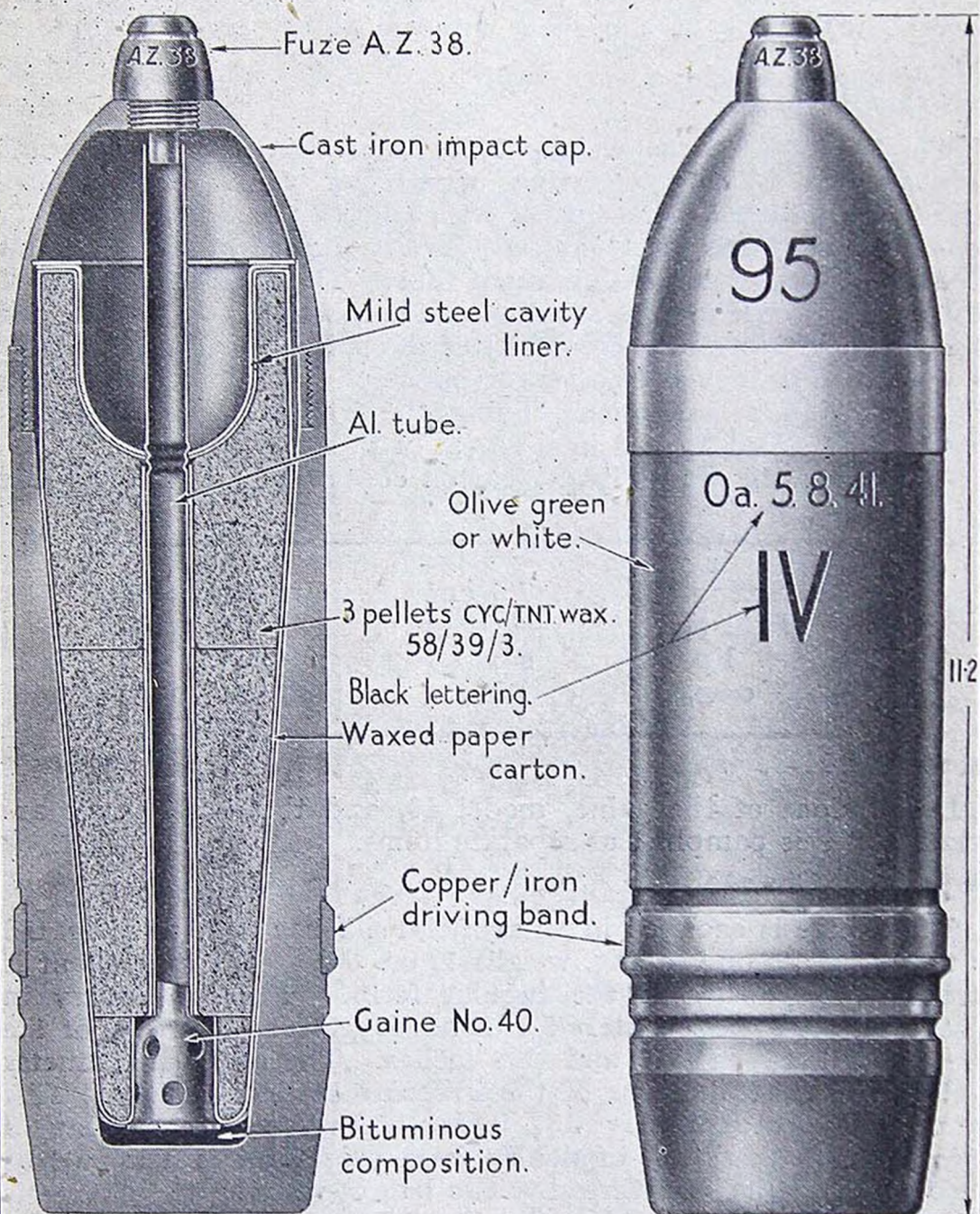

FIG. 14

surface of the cap to bear on a washer positioned over the liner of the cavity in the bursting charge. The cavity liner is pressed from dead mild steel sheet of 1 mm. thickness and is flanged to cover the top of the bursting charge. An aluminium tube, to connect the fuze with the gaine in the base of the shell cavity, passes through a hole in the base of the liner, where it is secured by crimping of the tube. The weight of the shell without filling, fuze or gaine is 8.46 lb.

Bursting Charge

The bursting charge weighs 1 lb. 3 oz. 9 dr. and comprises three pressed blocks consisting of 60 per cent. of cyclonite, phlegmatised with 5 per cent. of wax and 40 per cent. of T.N.T. The upper block has the "hollow" cavity formed in the head and a central channel for the aluminium tube. The intermediate block also has a channel for the aluminium tube, whilst the lower block is in annular form and accommodates the gaine. The three blocks are contained in a waxed paper carton which is secured in the shell by a bituminous composition lining the walls. A layer of this composition is also formed in the base of the shell cavity.

A label on the waxed paper carton containing the filling reads as follows:—

| | | |
|----------|------------|--------|
| Sprldg. | d. 7.5 cm. | Gr. 38 |
| H.5. (K) | elg | 40 |
| + Fp.02 | slb | 39 |
| cwg | 95 | 433/40 |

Gaine and Fuze

Descriptions of the gaine, model 40, and the A.Z.38 fuze are included in this pamphlet as separate items.

Propellant Charge

The charge is enclosed in an artificial silk bag and, as indicated by the markings on the bag, weighs 12 oz. 8 dr. The propellant is nitrocellulose powder in the tubular form. The tubes vary in colour and are approximately 5.3 inches long. The diameter of the hole varies between .053 and .068 inches. The external diameter of the tube varies because of the irregular exterior surface. This diameter is approximately .131 inches. An igniter consisting of perforated circular discs of double base propellant is attached at the base of the bag by thread. The bag containing the charge is marked "7.5 cm. Kw.K, Stu.G. 7.5 cm. 355 g. Nz.R.P. (135.5,5/2)."

Primer

The C/22 electric primer is described in Pamphlet No. 4, page 31.

Action of Shell

On impact the cap is shattered and the fuze functions. The flash from the fuze passes through the aluminium tube to the detonator in the gaine at the base of the shell cavity. This results in the detonation of the P.E.T.N./wax filling of the gaine and thus brings about the detonation of the bursting charge from the base. The "hollow" in the head of the bursting charge has the effect of focusing the effect of the detonation to perforate the plate struck.

Perforation of Armour Plate

It is estimated that the shell will perforate 55 mm. of homogeneous armour at normal or 45 mm. of homogeneous armour at 30 degrees to the normal.

GERMAN 7.5 cm. L.G.40 Q.F. CARTRIDGE (7.5 cm. L.G.40 Hülsenkart)

The cartridge is used in the 7.5 cm. recoilless airborne gun (7.5 L.G.40) and is of the separate loading Q.F. type. The diameter of the short brass case is large in comparison with the calibre of the gun and a distinctive feature is the black plastic disc at the base. The designation of the equipment is given on a label affixed to the cardboard cup which closes the mouth of the case.

Case

The brass case is 6.1 inches in length and tapers from 4.8 inches in front of the flange to 4.5 inches at the mouth. The base of the case is designed to be destroyed on firing to allow some of the propellant gases to escape to the rear through a jet fitted to the breech block. A large circular hole formed in the base of the case is closed by a disc of black plastic. The disc is 3.4 inches in diameter and has a .65 inches primer hole at its centre.

Primer

The primer is the C/113 and is a percussion type which differs from the C/13nA in having a base diaphragm of .023 inches instead of .051 inches.

Propellant Charge

The propellant charge is contained in a silk cylindrical bag which is choked at the neck and has an igniter pocket at the base. The bag bears the following markings in red:—

" 7.5 cm. L.G.40
1.214 Kg
Digl. Str.P-9,2-(125 × 5 × 0,5)
Dbg. Nr. 9747
9.42 "

The igniter pocket is pale mauve in colour and is sewn to form nine compartments, each of which contains a granular igniter composition. The weight of the filling is approximately 10 grams.

The charge weighs 2 lb. 10 oz. 13 dr. and consists of a double base propellant (diethylene glycodinitrate and nitrocellulose) in the form of strips arranged vertically around a central tubular length. The strips are 4.92 inches long, .197 inches wide and .02 inches thick. The tubular propellant is closed at the ends by a disc of propellant and is 4.7 inches long. The external diameter is .55 inches and the internal .49 inches. The tube contains 247 grains of gunpowder.

The charge is retained in the case by an inverted cardboard cup in the mouth of the case. The cup carries a label giving the same particulars as those marked on the bag.

GERMAN 7.5 cm. L.G.40 HOLLOW CHARGE STREAM-LINED SHELL (7.5 cm. Granate 38, H1/B)

(Fig. 15)

The shell is fired from the 7.5 cm. recoilless airborne gun (7.5 cm. L.G.40). The streamlined shell is fitted with an ogival impact cap which forms the head and carries the small direct action nose fuze A.Z.38. The single driving band is of iron and a cannelure is formed behind it just above the streamlined portion of the base. The cap and shell are painted the normal dark olive green and have the following distinguishing markings:—

“ H1/B ” in black near the nose, indicating hollow charge.

“ 91 ” in black near the centre of the body, indicating the nature of bursting charge.

“ FES ” in white above the driving band and on the base.

This probably relates to the iron driving band.

The designation of the projectile and fuze are stencilled in black on the base of the shell.

The overall length of the fuzed shell is 12.2 inches and the weight, filled and fuzed, is 10 lb.

Shell

The body of the shell is comparatively thin walled with the cavity for the bursting charge tapered towards the base. An internal screwthread is formed at the front end for the assembly of the impact cap. The impact cap is more pointed than the dome-like cap of the shell for the 7.5 cm. tank gun and has a thicker wall. A fuze hole is formed at the nose and two flats, for the assembling tool, are formed near the base of the cap. On the inside of the cap a circumferential shoulder is formed to engage the adjusting washers, which are inserted above a steel washer covering the mouth of the cavity liner. The cone-shaped cavity liner is of

GERMAN 75_{cm} L.G.40:- SHELL, Q.F., HOLLOW CHARGE.
(GRANATE 38HL/B)

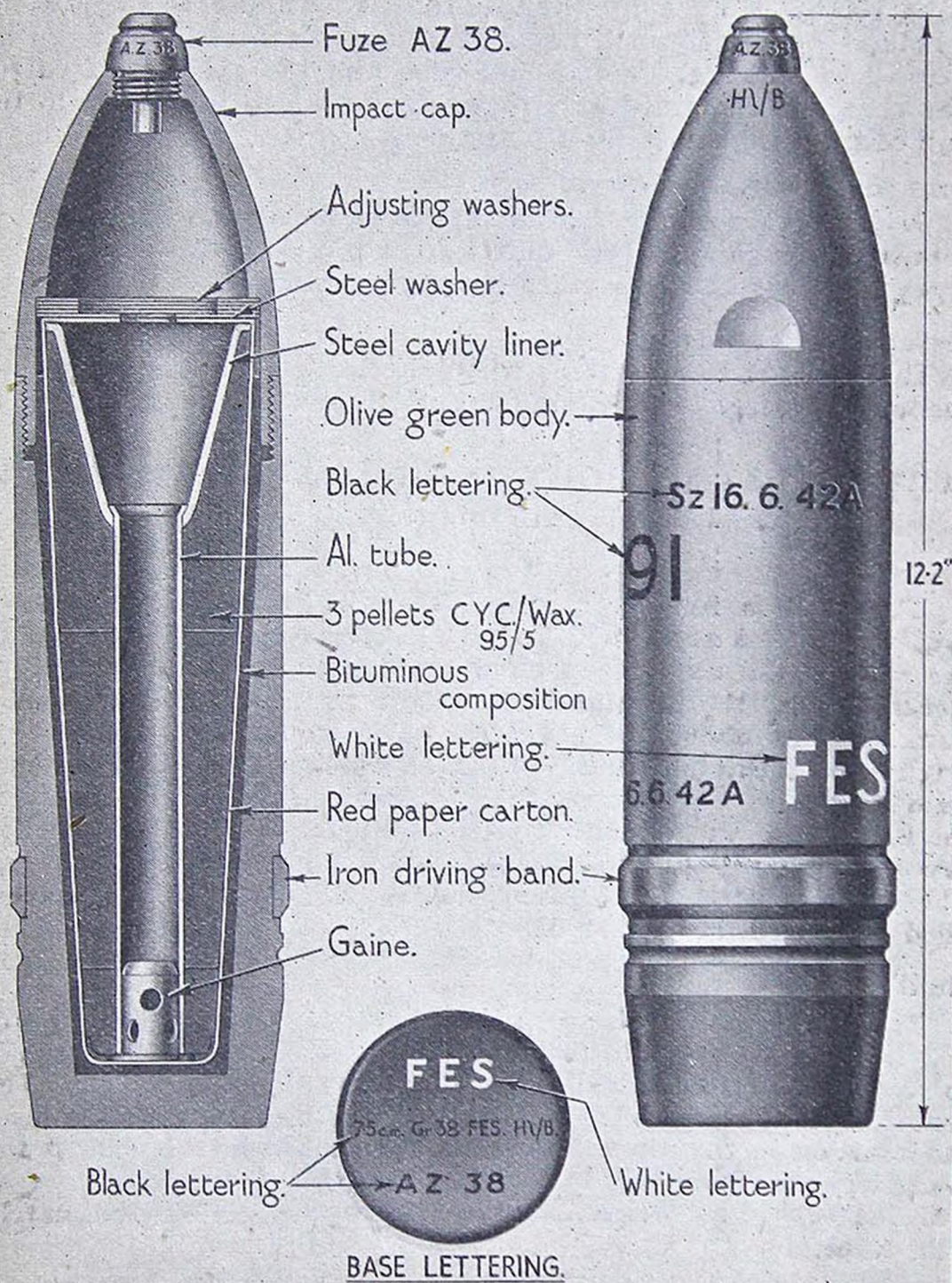

FIG. 15

steel with an aluminium tube fitted in a hole at the base. The tube extends from the liner to the gaine in the base of the shell cavity

Bursting Charge

The bursting charge weighs 1 lb. 2 oz. 6 dr. and consists of three blocks of cyclonite/wax 95/5. The upper block has the "hollow" cavity formed in its head and all three have a central channel in which the aluminium tube and the gaine are located. The charge is contained in a paper carton which is secured to the wall of the shell cavity by a bituminous composition.

Fuze and Gaine

A description of the A.Z.38 fuze is included in this pamphlet. Details of the gaine, which differs from the Zdlg.40 used in other types of hollow charge shell, are not yet available.

Perforation of Armour Plate

The shell, it is estimated, will perforate 60 mm. homogeneous armour at 30 degrees to the normal or 70 mm. at the normal.

GERMAN 7.5 cm. LIGHT INFANTRY HOWITZER H.E. SHELL (7.5 cm. Infanteriegranate 18)

(Fig. 16)

The shell is fired from the 7.5 cm. I.I.G.18 (light infantry howitzer) with a separately loaded Q.F. cartridge. The colour of the shell is the usual deep olive green with the numeral "13" stencilled near the head and the weight class stencilled in Roman numerals just above the shoulder. The stencilling is black. A single copper driving band, .16 inches wide, is fitted at 1.1 inches from the base. The nose fuze is stamped I.Igr.Z.23nA above the flange and is fitted with a setting plug for optional delay. The two setting positions are stamped "O" and "V" respectively. The overall length of the fuzed shell is 13 inches and the weight, filled and fuzed, is 12 lb. 2 oz.

Shell

The shell consists of two main parts, the body and the head. The head is screwed into the body and is screwthreaded internally to receive the fuze and a disc carrying an exploder container. The container is of steel and is screwthreaded externally near the head for insertion in the disc. Two slots are formed in the wall at the head for the inserting tool. The length of the container is 3.07 inches. The weight of the empty shell is approximately 9 lb. 12 oz.

Bursting Charge

The bursting charge, as indicated by the numeral "13" painted on the shell, consists of 1 lb. 4 oz. of cast Amatol 40/60 with a

GERMAN 7.5cm. Igr. 18, (or Jgr 18) H.E. SHELL.

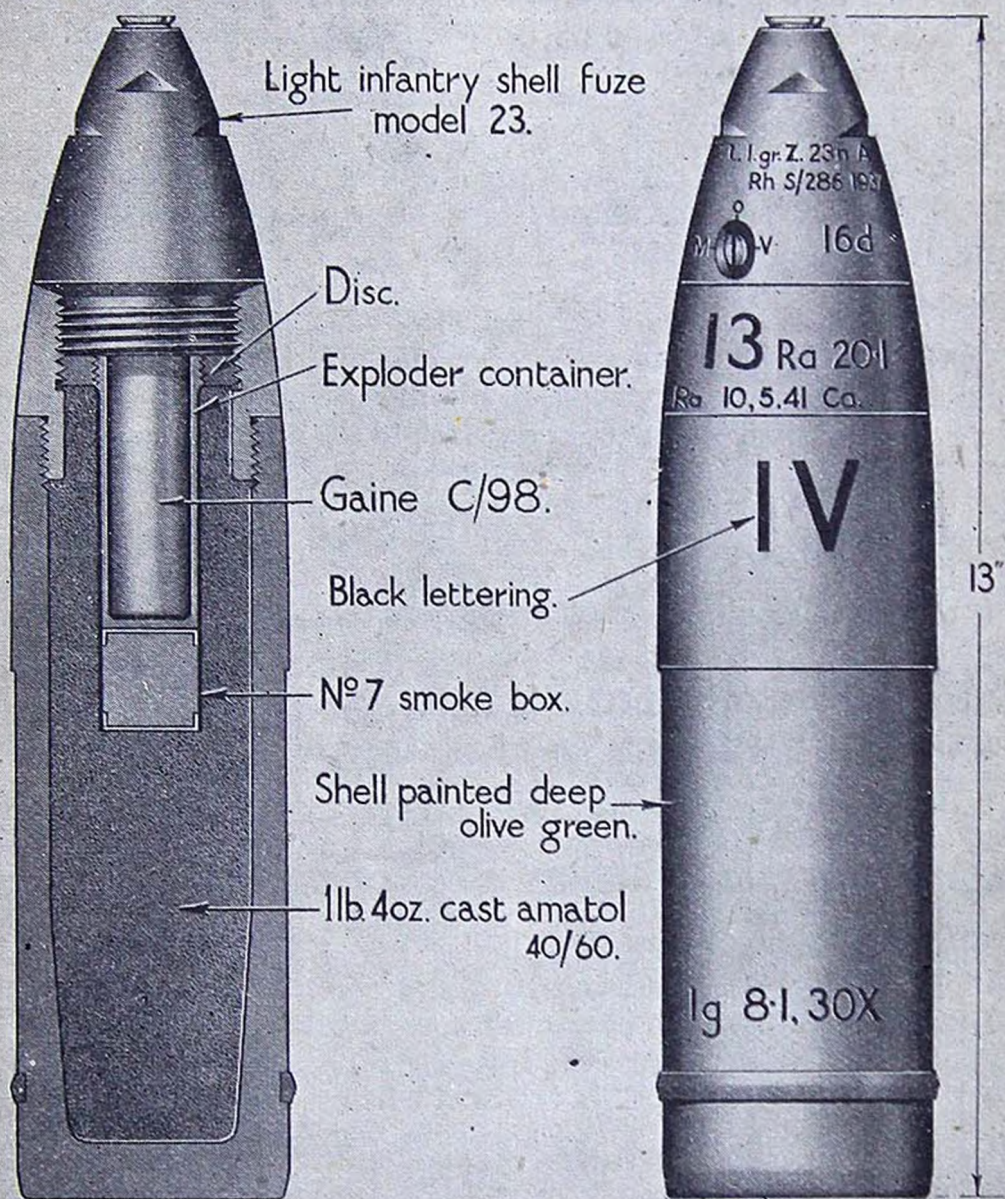

FIG. 16

cavity for the exploder container and a smoke box. The depth of the cavity, measured from the mouth of the fuze-hole, is 3.7 inches. The lower part of the cavity contains a No. 7 smoke box (Rauchentwicker Nr. 7) which is 1.1 inches in length.

Gaine

The gaine, carried in the exploder container, is the Gr. Zdlg. C/98 Np. This is the larger size of the C/98 gaine with a filling of P.E.T.N./wax. Further details are given in the section on German gaine in Pamphlet No. 6.

Fuze

The fuze, 1.Igr.Z.23nA, may be given on package labels as "1.Jgr.Z.23nA". A description of the fuze is included in Pamphlet No. 1, page 11.

Cartridge

The separate loading Q.F. cartridge used with this equipment consists of a brass case closed at the mouth by a millboard cup and containing a propellant charge, weighing approximately 2.5 oz., arranged in 5 sections. The percussion primer used is the C/12nA. The case is 3.5 inches in length and has stamped in the base the case model number, "6341", and the designation of the equipment, "1.I.G.18" (leicht Infanterie Geschutz, Model 18). Further details of the propellant charge are not yet available.

GERMAN 7.5 cm. LIGHT INFANTRY HOWITZER H.E. SHELL (7.5 cm. Igr. 18 Al.)

(Fig. 17)

The shell is fired from the 7.5 cm. light infantry howitzer (7.5 cm. 1.I.G. 18) and is fitted with the 1.Igr.A.Z.23nA fuze. The colour of the shell is the normal deep olive green with the letters "Al" marked in black 2.4-inch lettering at two positions round the shell, midway between the driving band and the shoulder. This marking indicates the inclusion of aluminium powder in the filling. The nature of the filling is indicated by the numeral "15" painted near the head of the shell. This is also in black. The overall length of the fuzed shell is 13 inches and the weight, filled and fuzed, is 12 lb. 2 oz. The single narrow driving band is of copper.

Shell

The shell is comparatively thin walled and is in two parts, the body and the head. The head is screwed into the body and is threaded internally to receive the fuze and a disc carrying the steel exploder container. The weight of the empty shell is approximately 9 lb. 12 oz.

GERMAN 75cm. Igr. 18 (or Jgr. 18) H.E./A1. SHELL

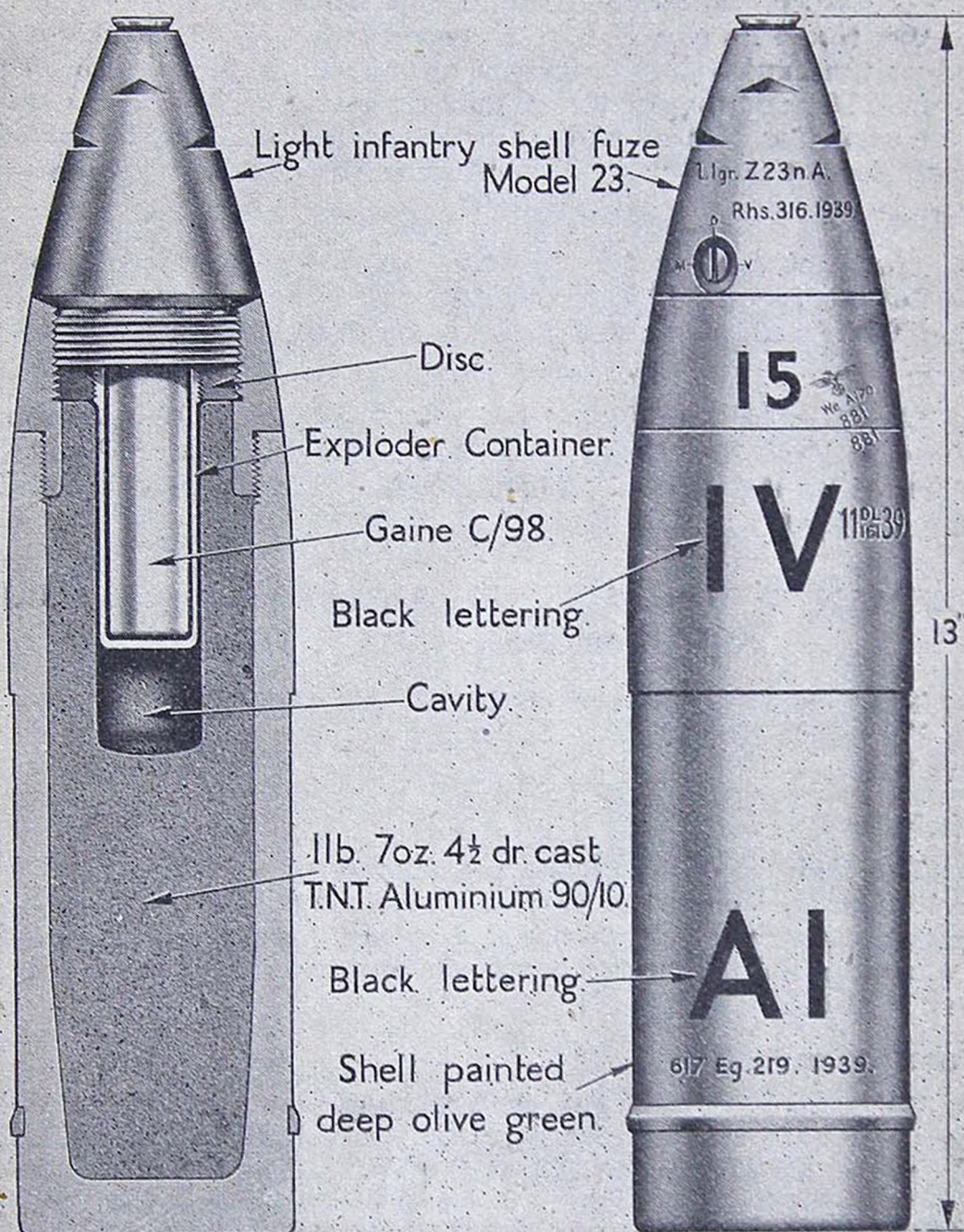

FIG. 17

Bursting Charge

The bursting charge consists of 1 lb. 7 oz. $4\frac{1}{2}$ dr. of cast T.N.T./aluminium, 90/10, with a density of 1.63. The aluminium powder passes the 240 B.S.S. The exploder cavity formed in the filling is deeper than is required to accommodate the exploder container and is unoccupied to a depth of 2.8 cm. below the base of the container. The dimensions of this space correspond with those of the No. 7 smoke box (Rauchentwickler Nr. 7) which is used below the exploder container in amatol-filled shell for this equipment. The addition of the aluminium gives rise to a very considerable evolution of heat and so increases the available energy of the explosive. The duration of the flash is also considerably prolonged.

Gain

The gain, carried in the exploder container, is the Gr.Zdlg.C/98Np. This is the larger size of the C/98 gain, filled P.E.T.N./wax, of which details are given in Pamphlet No. 6.

Fuze

The fuze has optional delay of .15 seconds. A description is given in Pamphlet No. 1, page 11. The abbreviated designation stamped on the fuze is "1.İgr.Z.23nA", but on package labels it may be given as "1.Jgr.Z.23nA".

GERMAN 7.5 cm. PAK 40 AND Kw.K40 A.P.C.B.C. SHELL 39 (7.5 cm. Pzgr. 39)

The general details and method of filling of this shell are given in Pamphlet No. 7. The following metallurgical details are now available:—

Shell Body

The body is of composite construction, the ogival head being welded to the cylindrical portion at the shoulder. Both component parts are machined from rolled bar and hardened. The Vickers Diamond Hardness figures vary from approximately 800 at the nose to 400 at the base.

Penetrative Cap

The cap is drop-forged or hot upset from rolled bar and is hardened only at the forward part. The V.D.H. figure varies from about 630 at the nose to 200 at the skirt. The cap is attached to the shell by lead-tin solder. A band of knurling is formed above cannellure for the attachment of the ballistic cap.

Ballistic Cap

The ballistic cap is pressed from dead mild steel sheet of about .04 inches thickness.

GERMAN 7.62 cm. CARTRIDGE, Q.F., H.E. OF RUSSIAN ORIGIN (Sprgr.Patr.280 (r) - russ 354 M - (Tp))

(Figs. 18 and 19)

This fixed Q.F. Russian ammunition is used by the Germans in the 7.62 cm.F.K. 296 (r) russ 36, a light Russian field gun. The shell is painted a dark grey and stencilled in black and red. In some instances a blue band is painted round the shell below the shoulder. The nose fuze is of steel and is fitted with a screwed cap. Stencilling in black on the side of the case includes the abbreviated designation of the equipment in the form "7.62 CM FK 296 (r) - russ 36 -". The normal charge temperature on which the weight of the propellant charge is based is indicated by the marking "P.T. + 25°C." in red near the base of the case. The marking "Sprgr", indicating the nature of the shell, appears in white paint on the base of the case. The overall length of the round is approximately 25.7 inches and the weight 19.4 lb.

The complete round consists of the following components:—

Shell filled T.N.T.

Brass cartridge case.

Propellant charge of nitrocellulose powder.

Percussion primer.

Combined direct action and graze fuze.

Shell (Fig. 18)

The streamlined shell is of forged steel with a band formed below the shoulder and another above the driving band. These bands are not painted. The driving band is wholly of copper. A nose adapter of steel is screwed into the head of the shell. The adapter is shaped to coincide with the contour of the head and is screwthreaded internally to receive the fuze. The weight of the empty shell with the adapter is 11.3 lb.

The bursting charge consists of approximately 1 lb. 8 oz. of cast T.N.T. with a cavity at the top to receive the magazine of the fuze. The T.N.T. corresponds to the "Grade I" used in the British service.

Case

The brass cartridge is 15.1 inches in length and is not necked. The primer hole in the base is .99 inches in diameter and has 14 screwthreads to the inch. The flash-hole at the inner end of the primer boss is closed by a cloth disc which is shellacked in position.

Propellant Charge

The propellant charge consists of 2 lb. 4 oz. 9 dr. of nitrocellulose powder in the form of short multi-tubular grains. The

GERMAN 7.62 cm. F. K. 296(r) russ 36:- SHELL, Q.F., H.E. WITH D.A./GRAZE FUZE.
(RUSSIAN ORIGIN)

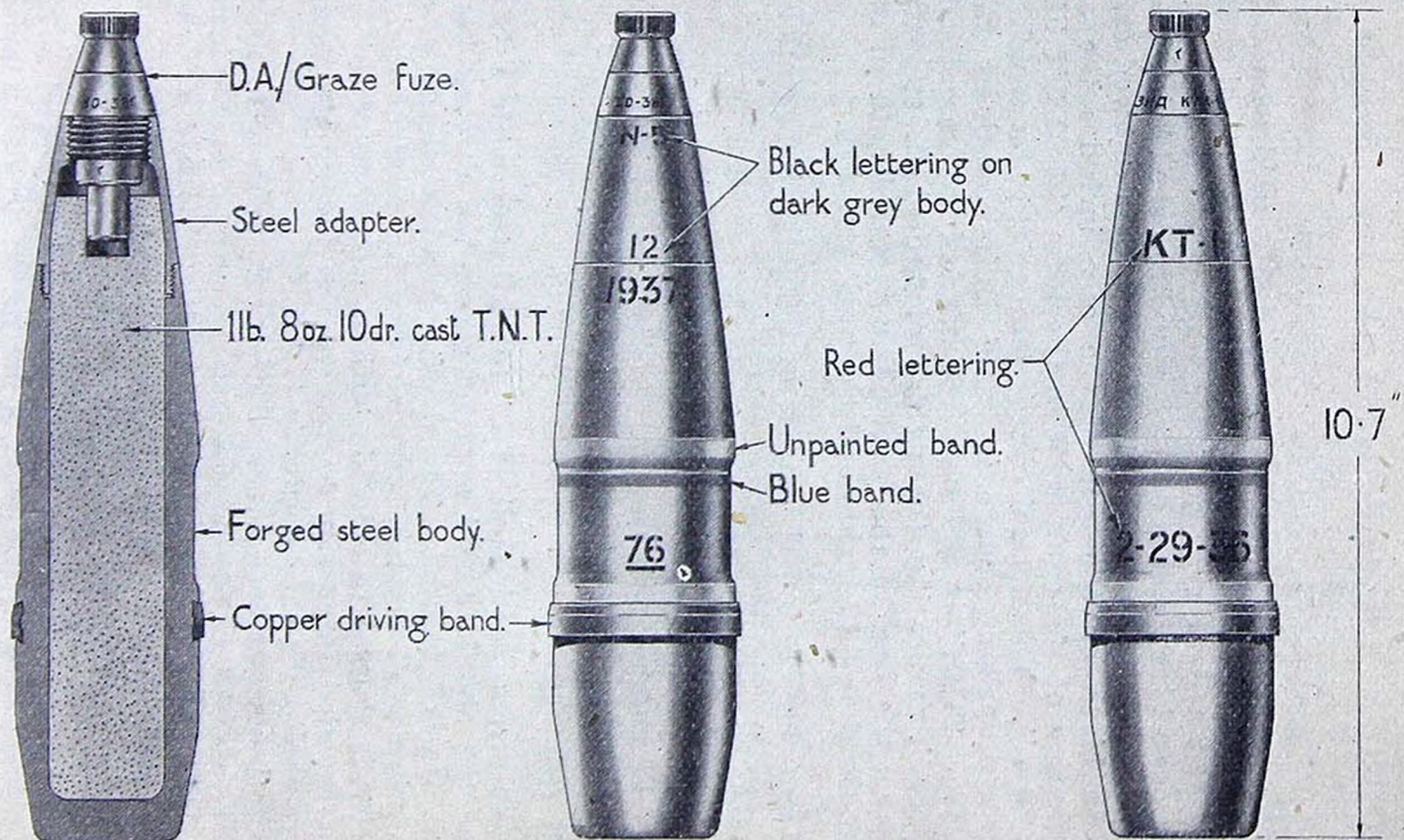

FIG. 18

grains average .477 inches in length and .231 inches in diameter and have 7 perforations. The mean web thickness is .042 inches.

The propellant is apparently of American manufacture, the composition as found by analysis being:—95.83 per cent. of nitrocellulose (nitrogen content 13.21 per cent.), .89 per cent. of diphenylamine, .3 per cent. of nitroso diphenylamine and 2.98 per cent. of volatile matter.

Primer

The percussion primer is of the type described in Pamphlet No. 6, page 19.

Fuze (Fig. 19)

The steel body of the fuze has an aluminium magazine screwed in at the base and a central recess which contains the graze arrangement. The recess has a flash-hole in the base leading to the magazine and is screwthreaded at the forward end to receive the steel head of the fuze.

The brass graze pellet carries a 1.9 grain igniferous detonator at the head and has a spigot at the base which seats in the flash-hole leading to the magazine. A copper washer, fitted to the base of the pellet, in conjunction with the spigot provides a seal against the flash from the detonator if initiated prematurely. A central recess is formed in the pellet, apparently for adjustment of the weight and possibly as a trap for debris from the detonator. The head of the pellet is flanged to engage the inner arms of the retaining spring.

The brass retaining spring is fitted over the head of the graze pellet and is in the form of a capsule with a perforation in the head to coincide with the detonator, four sprung inner arms to engage the flanged head of the pellet and four similar outer arms which engage the arming sleeve.

The brass arming sleeve fits over the retaining spring and, by engaging the outer arms of the spring, holds the graze pellet in the base of its recess. Forward movement of the sleeve is prevented by the base end of the fuze head. The sleeve is in the form of a hollow cylinder with an internal groove to engage the outer arms of the retaining spring when armed and an external flange at the head to engage the arming spring. The other end of the spiral arming spring is supported by a step formed in the body recess.

The steel head of the fuze is recessed at the nose to accommodate the striker assembly and at the base to permit the forward movement of the graze pellet on functioning. The diaphragm between the two recesses is drilled for the needle of the striker and stepped to form a support for the striker spring. An external screwthread is formed at the nose to receive the steel cap.

A brass check ring with four internal projections is fitted in the base recess of the head to prevent the graze pellet carrying the

RUSSIAN D.A/GRAZE FUZE USED IN GERMAN 7.62c.m. H.E. SHELL.

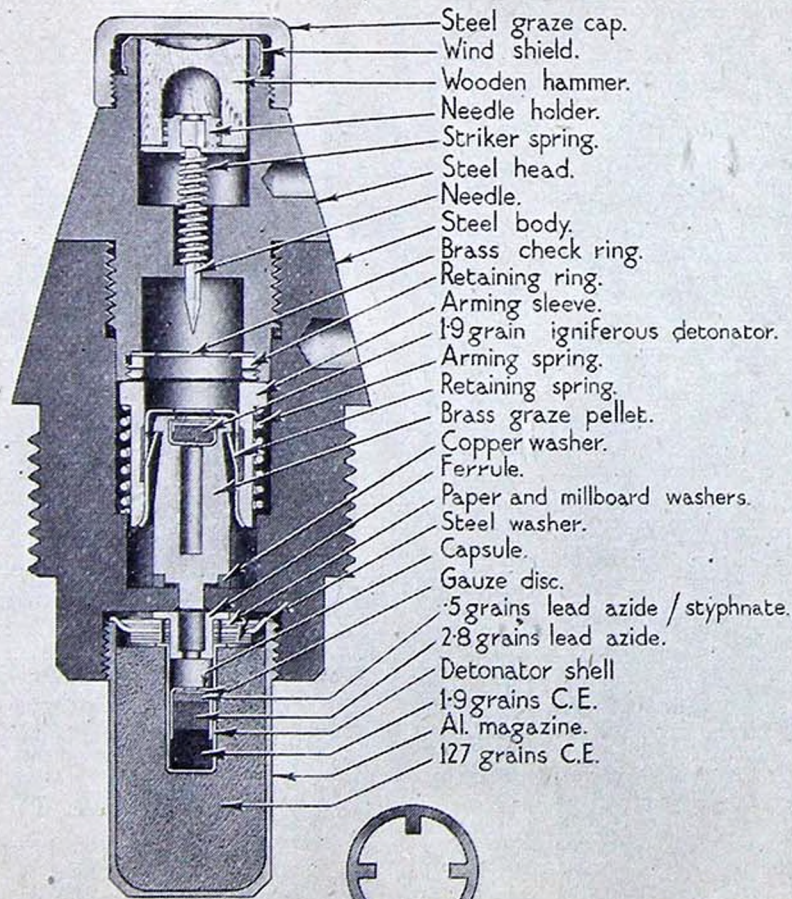

Brass check ring.

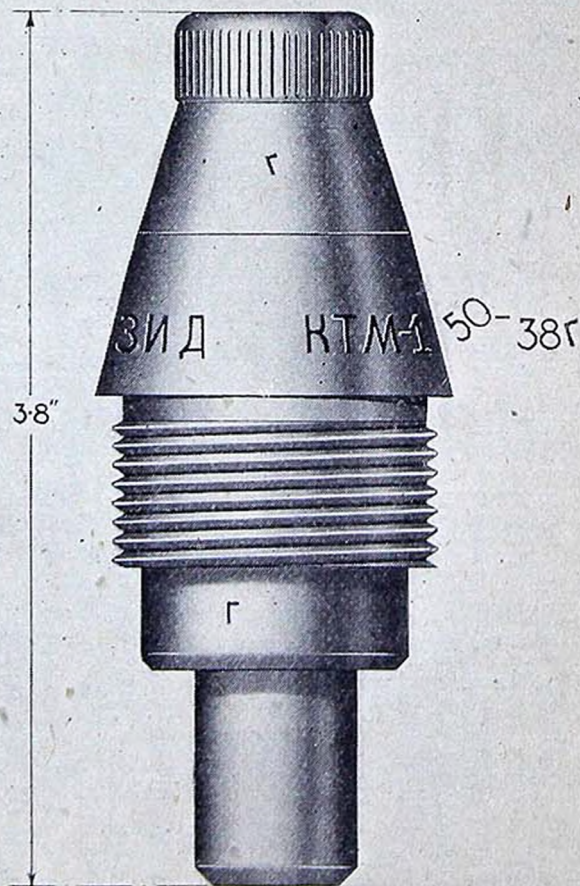

FIG. 19

detonator forward on to the striker during flight. The check ring is secured by a retaining ring screwed into the mouth of the recess.

The striker assembly consists of a steel needle with a holder at the head, which supports a wooden hammer, and a spiral spring held between the holder and the diaphragm. The recess containing the striker assembly is closed against air pressure by a brass wind shield.

The magazine filling is designed to function as a gaine and consists of 127 grains of C.E. with a detonator at the head. The detonator is embedded in the C.E. filling and contains 2.8 grains of lead azide with .5 grains of lead azide/styphnate above and 1.9 grains of C.E. below. The detonator filling is covered by a perforated capsule and a gauze disc. The detonator shell is closed at the mouth by a brass perforated ferrule which is fitted in an arrangement of paper and millboard washers and the steel washer closing the head of the magazine.

Action

For graze action the cap remains on the fuze.

On acceleration the arming sleeve sets back over the retaining spring and compresses the arming spring. In this position the outer arms of the retaining spring engage in the internal groove in the sleeve and retain the sleeve in this position relative to the graze pellet. During deceleration the compressed arming spring pushes the sleeve forward, taking with it the graze pellet until the pellet is stopped by the projections on the check ring. On graze the momentum of the pellet overcomes the resistance of the check ring and carries the detonator on to the needle. The flash produced by the igniferous detonator passes to the detonator in the magazine, which brings about the detonation of the C.E. filling.

For direct action the cap is removed before loading so that in addition to the graze pellet moving forward, the needle is driven in on impact.

GERMAN 10.5 cm. HOLLOW CHARGE SHELL, MODEL 39 (10 cm. Granate 39 rot HI.)

(Fig. 20)

The shell is fired from the 10.5 cm. gun howitzer (10.5 cm. I.F.H.18). A dome-shaped impact cap with a fuze-hole at the top is fitted to the shell, which has a single bi-metal driving band. Two cannellures are formed between the driving band and the base. The shell and cap are painted the usual dark olive green with a red band immediately above the driving band. The numeral "95", painted in black on the impact cap, indicates the nature of filling. The overall length of the shell with fuze A.Z.38 is approximately 15.3 inches and the filled weight 25.5 lb.

The cap and the shell with its central tube are similar to those described for the shell fired from the 7.5 cm. tank gun. The cavity liner differs in being cone-shaped with a rounded base.

Bursting Charge

The bursting charge weighs 3 lb. 14 oz. 10 dr. and consists of 3 blocks of hot pressed cyclonite, T.N.T. and wax, the percentage

GERMAN 10.5 cm. HOLLOW CHARGE SHELL MODEL 39 (10 cm. Granate 39 rot. Hl.)

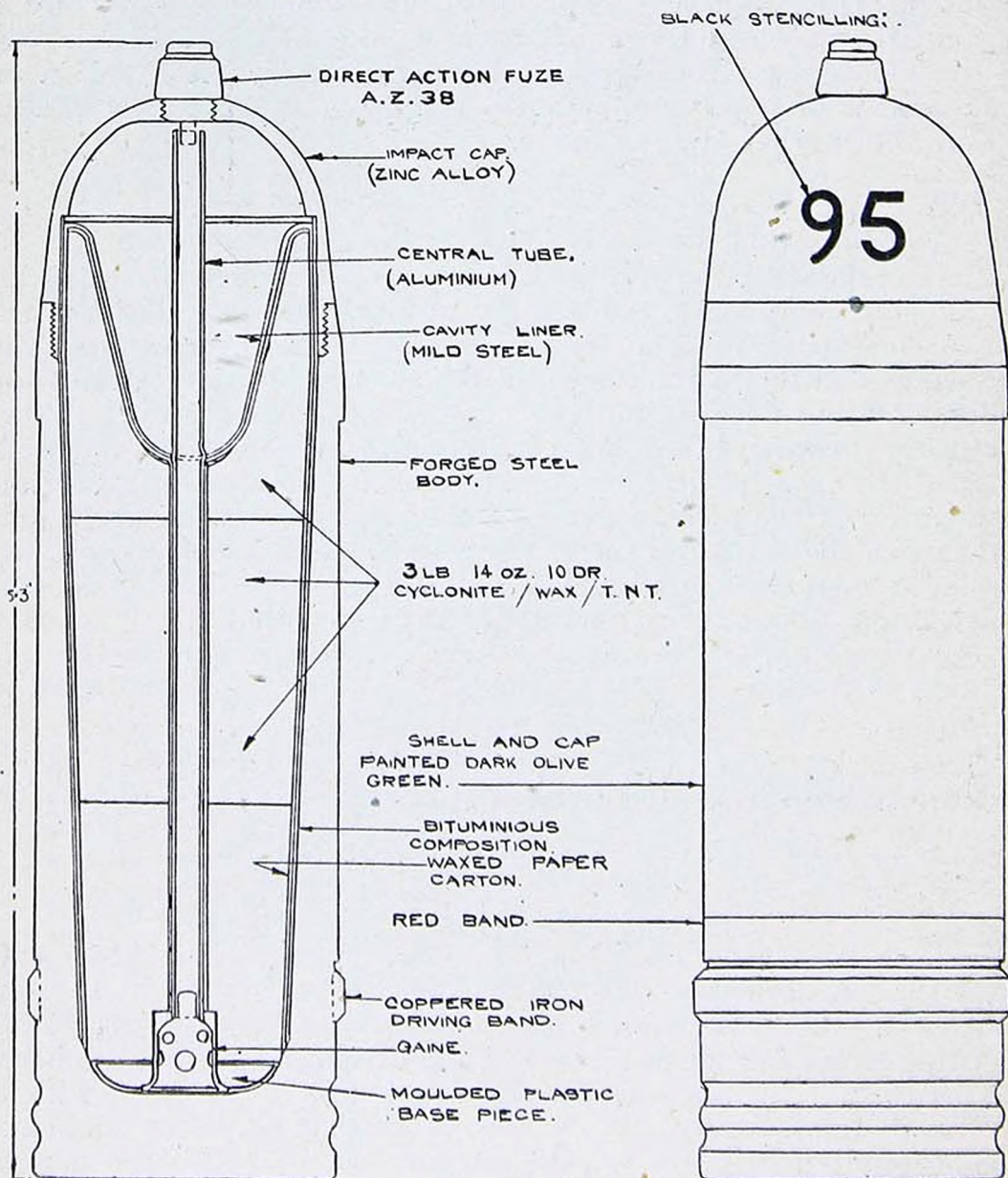

FIG. 20

of each being approximately 56.8, 40.3 and 2.9 respectively. A channel is formed through the blocks for the central tube connecting the fuze to the gaine and the "hollow" cavity is formed in the head of the upper block. The lower block has a cavity at the base to accommodate the gaine. The three blocks are contained in a waxed paper carton with a base piece of moulded plastic which is shaped to fit the base of the shell cavity. The carton is attached to the wall of the shell by a bituminous composition.

A label on the carton is printed as follows:—

| | | |
|--------------------|----|------|
| Sprengladung | | |
| der 10 cm. Gr. 39 | | |
| H5 (S.H.) Krl.41 | | |
| Fp02 (umKr) elg.41 | | |
| rdf | 95 | 9.41 |

Fuze and Gaine

The fuze-hole and the filling appear to be designed for the fuze A.Z.38 and the gaine Zdlg.40 as used with the shell for the 7.5 cm. tank gun. Descriptions of the fuze and gaine are included in this pamphlet.

Perforation of Armour

The estimated perforation of homogeneous armour is 95 mm. at the normal and 80 mm. at 30 degrees to the normal.

GERMAN 15 cm. MEDIUM HOWITZER (15 cm. s.F.H.18) Q.F. CARTRIDGE

The cartridge is of the separate-loading Q.F. type consisting of a brass case containing a charge of double base propellant in 6 sections. The case is fitted with a C/12 percussion primer and is closed at the mouth by a cardboard cup. A special charge, consisting of sections 7 and 8, is packed in a cylindrical metal container. These sections are inserted in the cartridge case, in place of the normal contents, when required.

Case

The brass case is 10.2 inches in length and has stamped in the base the model number of the case, "6350", and the designation of the equipment, "s.F.H.18".

Propellant Charge

The charge, comprising sections No. 1 to No. 6 inclusive,

consists of 2 lb. 13 oz. 15 dr. of double base flake propellant (diethylene-glycoldinitrate and nitrocellulose) and a 1 lb. 3 oz. 6 dr. igniter also of double base propellant flake (nitroglycerine and nitrocellulose). These weights are based on a normal charge temperature of 25°C.

Each of the sections is enclosed in a flat bag of artificial silk. The bags for sections No. 1 and No. 2 are semi-circular, No. 1 being stitched to the top of circular igniter bag and No. 2 being placed beside it to form a circle. The remaining bags are circular, the diameter being approximately 6.5 inches. The bags are stencilled in black to indicate the designation of the equipment, the charge numeral, the weight, nature and size of the propellant and the dates of manufacture and filling. Sections Nos. 1, 5 and 6 are also stencilled "Bleidraht im Beutel" to indicate the inclusion of lead wire in the bag as a decoppering agent. The standard normal for the charge temperature is stencilled in red, "(P.T. + 25°C.)".

The weights, natures and sizes of the flake propellants, as marked on the bags, are as follows:—

| Section | Nature of Propellant | Size of Flake | | Weight of Section | | |
|---------|----------------------|---------------|------------------|-------------------|-----|---------|
| | | Metric | Inches | Grams | lb. | oz. dr. |
| Igniter | Ngl. Bl.P. 12,5 | 40 × 40 × 0.2 | 1.6 × 1.6 × .008 | 550 | 1 | 3 6 |
| 1 | Digl. Bl.P. 10,5 | 4 × 4 × 1,2 | .16 × .16 × .05 | 62 | — | 2 3 |
| 2 | ditto | ditto | ditto | 122 | — | 4 5 |
| 3 | ditto | ditto | ditto | 124 | — | 4 6 |
| 4 | ditto | ditto | ditto | 208 | — | 7 5 |
| 5 | ditto | ditto | ditto | 312 | — | 11 0 |
| 6 | ditto | ditto | ditto | 475 | 1 | 0 12 |

Special Charge (Sonderkart 7 u 8)

The special or supercharge comprises sections Nos. 7 and 8 and is packed in a cylindrical metal container. The lid of the container is stencilled "D Sond—kart 7 u 8 s. F. H.18 o.B.D.". The letters "o.B.D." indicate the absence of the lead wire decoppering agent. An instructional label on the container is worded to the effect that before inserting sections 7 and 8 in the cartridge case, the sections in the case, including the igniter, should be removed.

Section No. 7 is contained in a cylindrical bag of artificial silk about 8.5 inches long and 6 inches in diameter with an igniter formed in the base and choked at the neck. The bag is marked with the charge numeral "7D" in black. The numeral is enclosed by a red circle. The following details are stencilled on the side of the bag in black:—

“ s.F.H.18 ”

—Model of equipment.

“ 2.387 Kg.”

—Weight of propellant charge.

“ Digl.Rg.P.10,5 (1.9 × 15/4) ” —Nature, shape and size of propellant.

The place and date of manufacture of the propellant and the filling of the section are also given. The marking “ P.T. + 25°C.” is in red.

The igniter at the base of the bag is marked “ 440 g. Digl.Bl.P.—10,5 (3.3.0,8) ”.

The propellant charge, as indicated by the marking, consists of 5 lb. 4 oz. 3 dr. of double base propellant (diethylene-glycoldinitrate and nitrocellulose) in the form of perforated discs. The dimensions of the disc being:—thickness .075, diameter .6, diameter of hole .16 inches.

The propellant filling used in the igniter, as indicated by the markings, consists of 15 oz. 8 dr. of double base propellant (diethylene-glycoldinitrate and nitrocellulose) in the form of square flake. The dimensions of the flake are: .118 × .118 × .032 inches.

Section No. 8 is contained in a flat, circular bag of artificial silk about 7 inches in diameter. The bag is marked with the charge numeral “ 8D ” in black with a red circle around the numeral. The remaining markings are the same as those on the side of Section 7, except that the weight is given as “ 768 g ”, i.e., 1 lb. 11 oz. 1 dr.

GERMAN 15 cm. MEDIUM HOWITZER ANTI-CONCRETE SHELL (15 cm. Gr. 19 Be)

(Fig. 21)

The shell is fired from the 15 cm. medium howitzer (15 cm. s.F.H.18) and is fitted with a ballistic cap, two bi-metal driving bands and a base fuze. The abbreviated designation of the shell, “ Gr.19 Be ”, is included in the stamping in the base of the fuze. The shell and ballistic cap are painted the normal dark olive green and stencilled in black. The overall length of the capped shell is 23.5 inches and the weight, filled and fuzed, is approximately 95 lb. 5 oz.

Shell

The shell is of the pointed type and is fitted with a base adapter. The head of the shell is coned near the nose and has a flat tip. The cavity for the bursting charge is larger than that in a piercing shell and has a wooden block occupying the reduced forward end. The light ballistic cap, welded to the shell, is shaped to correspond with contour of the shell and has a rounded head.

A steel exploder container is screwed into the base adapter from the underside. The weight of the empty shell is 83.5 lb. The body is hardened and tempered throughout, the V.D.H. figures averaging about 320.

Bursting Charge

The bursting charge, weighing 7 lb. 2 oz., is contained in a cardboard carton and is of the block type comprising 4 pressed

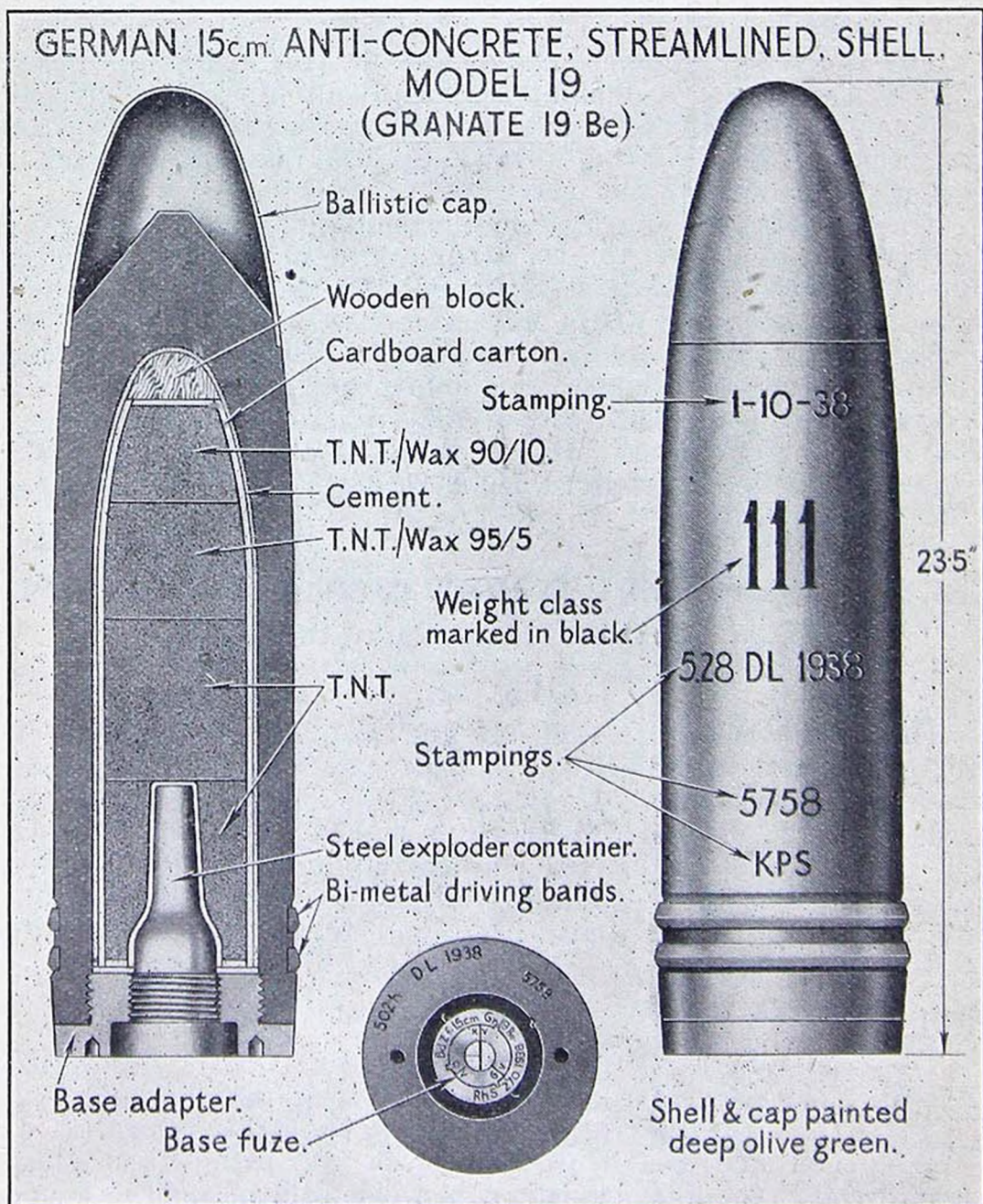

FIG. 21

pellets. The two upper pellets are of T.N.T./wax, the percentage of T.N.T. and wax in the first being 90/10 and in the second 95/5. The two lower pellets are of T.N.T., the base pellet being formed with a cavity to receive the exploder container. The carton containing the charge is cemented to the wall of the shell cavity.

Gaine

The gaine, carried in the exploder container above the fuze, is a Zdlg. C/98 filled picric acid (for details see Pamphlet No. 6).

Fuze

The base fuze is screwed into the enlarged base end of the exploder container and is provided with a setting plug and setting graduations in the base for two optional delays. Further details are not yet available.

GERMAN 21 cm. HEAVY HOWITZER (21 cm. Mrs. 18) Q.F. CARTRIDGE

The cartridge is of the separate-loading Q.F. type consisting of a brass-plated steel case with the percussion primer C/12 n A.St. and a propellant charge of double base composition arranged in sections to form 5 charges for normal use. These sections are packed in a cylindrical container. A special or super charge, section No. 6, is also used in place of the lower charges. The supercharge is also packed separately in a cylindrical container.

Case

The steel case, coated with brass, has the model number "6351 St" and the designation of the equipment "21 cm. Mrs. 18" stamped in the base. The length of the case is 16.2 inches.

Propellant Charge

The propellant charge, comprising sections Nos. 1 to 5 inclusive, consists of 15 lb. 14 oz. 1 dr. of double base propellant and a 1 oz. 12 dr. igniter of nitrocellulose powder. These weights are based on a normal charge temperature of 25°C.

Each of the sections is enclosed in a white flat bag of artificial silk excepting the No. 1 section, which consists of two such bags sewn together at four points on the circumference, with a pink igniter bag at the base. The bags containing sections Nos. 2 and 3 are semi-circular. All of the remainder are circular. The bags are marked in black to indicate the charge numeral, the weight, nature and size of propellant and the place and date of manufacture of the propellant and the filling of the charge. The upper bag of section No. 1 is also marked "Bleidraht im Beutel" to indicate the inclusion of lead wire as a decoppering agent. The charge

temperature normal of 25°C. is indicated by the marking " P.T. + 25°C." in red.

Section No. 1 is a composite charge, each of the bags containing a double base propellant of the same basic composition (diethylene-glycoldinitrate and nitrocellulose), but of a different shape and size. The propellant in the lower bag is in the form of square flake, whilst that in the upper and in the other sections is in the form of circular discs with a central perforation.

The weights, natures and sizes of propellants, as marked on the bags, are as follows:—

| Section | Nature of Propellant | Size | | Weight of Section | |
|--------------|----------------------|------------|-------------------|-------------------|-------------|
| | | Metric | Inches | Grams | lb. oz. dr. |
| Igniter | Nz.Man N.P. | (1,5-1,5) | .059 × .059 | 50 | — 1 12 |
| 1 (base bag) | Digl. Bl.P.10.5 | (3.3.0,8) | .118 × .118 × .03 | 1000 | 2 3 4 |
| 1 (top bag) | Digl. Rg.P.—10.5 | (1,9-15/4) | .075 × .59-158 | 1377 | 3 — 9 |
| 2 | ditto | ditto | ditto | 527 | 1 2 9 |
| 3 | ditto | ditto | ditto | 697 | 1 8 9 |
| 4 | ditto | ditto | ditto | 1480 | 3 4 3 |
| 5 | ditto | ditto | ditto | 2124 | 4 10 15 |

Supercharge (Sonderkart 6)

The cylindrical rolled paper container in which this charge, section No. 6, is packed is marked in white, " Sonderkart 21 cm. Mrs.18 "

The charge is contained in a cylindrical bag of white artificial silk, which is choked at the neck and has a pink base containing the igniter composition. The bagged charge is approximately 20 inches long and bears the following marking, in addition to the charge numeral " 6 ", in black:—" 21 cm. Mrs.18, 15,537 kg. Digl. R P.—G1—(500—5,6/3) ". The normal charge temperature, on which the weight of the charge is based, is indicated by the marking " P.T.25° C." in red.

The weight of the propellant charge, as indicated by the markings, is 34 lb. 3 oz. 11 dr. The charge consists of a bundle of tubular cords tied in two places with string. The tubular cords are approximately 19.7 inches long and .22 inches in diameter. The internal diameter of the tube is .12 inches. The propellant is of the double base type and consists basically of diethylene-glycoldinitrate and nitrocellulose.

GERMAN 21 cm. HEAVY HOWITZER ANTI-CONCRETE SHELL (21 cm. Gr.18 Be)

(Fig. 22)

The shell is fired from 21 cm. Mrs. 18, a separate-loading Q.F.

GERMAN 21cm. ANTI-CONCRETE STREAMLINED SHELL

MODEL 18 (GRANATE 18 Be)

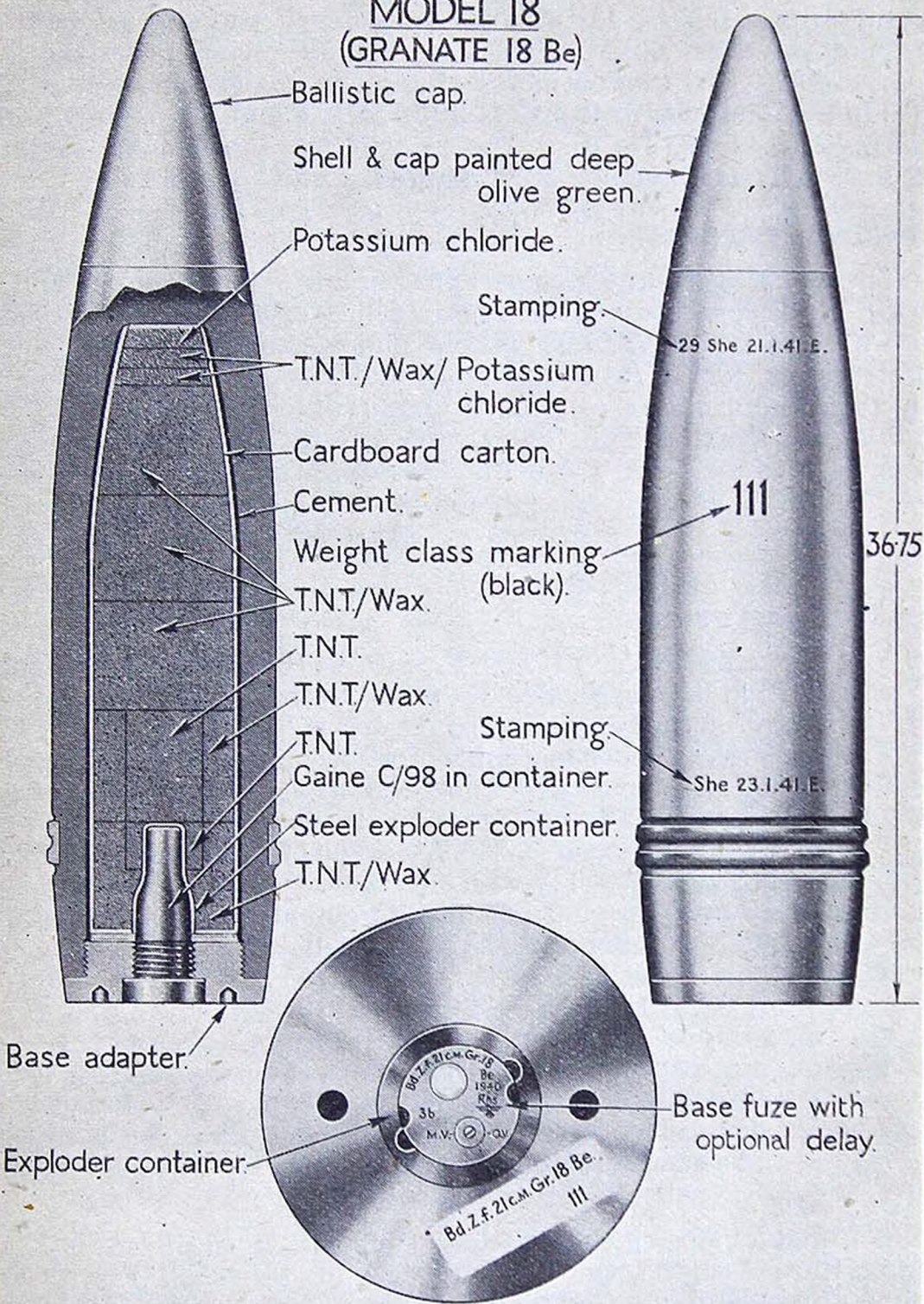

FIG. 22

heavy howitzer and is, in general design, similar to the shell of the same nature described for the 15 cm. s.F.H.18. Two driving bands of the copper and iron type are fitted. The ballistic cap, welded to the head, is not rounded at the nose to the same extent as that on the 15-cm. shell. The shell and cap are painted the normal dark olive green and the abbreviated designation, "Gr.18 Be", is included in the stampings in the underside of the base fuze. The overall length is 36.75 inches and the weight, filled and fuzed, is 267.75 lb. The weight of the empty shell is 237 lb. 3 oz. The average VDH figure for the body is 290.

Bursting Charge

The bursting charge weighs approximately 25 lb. 9 oz. and is of the block type comprising a main filling of T.N.T./wax pellets, an intermediary of T.N.T. pellets and desensitized nose pellets consisting of T.N.T./wax/potassium chloride. The pellets, 10 in all, are contained in a cardboard carton which is cemented to the wall of the shell cavity. The carton is stencilled "Sprengladung 21 cm. Gr.18 Be" and a label at the base is printed as follows:—

" Sprengldg d 21 cm. Gr. Be, Fp 10 (Sulfiltri) Rd.1939
Fp. 02 (umkr)."

The details of the pellets comprising the filling from base to nose are as follows:—

- 4 lb. 2 oz. pellet of T.N.T./wax 94/6 at the base shaped from the underside to fit over the exploder container and at the upperside to receive a T.N.T. pellet.
- 8 oz. T.N.T. pellet in annular form which fits into the upperside of the base pellet and surrounds the upper end of the exploder container.
- 4 lb. $0\frac{3}{4}$ oz. pellet of T.N.T./wax 90/10 in annular form to receive a T.N.T. pellet.
- 1 lb. $5\frac{1}{2}$ oz. T.N.T. pellet in solid cylindrical form which fits into the annular T.N.T./wax pellet.
- 5 lb. 2 oz. pellet of T.N.T./wax 90/10.
- 5 lb. $4\frac{1}{2}$ oz. pellet of T.N.T./wax 91/9.
- 4 lb. 2 oz. pellet of T.N.T./wax 91/9.
- 6 oz. disc pellet of T.N.T. 60.5 per cent., wax 5.4 per cent. and potassium chloride 34.1 per cent.
- 5 oz. disc pellet of T.N.T. 44.1 per cent., wax 5.6 per cent. and potassium chloride 50.3 per cent.
- 5 oz. disc pellet of potassium chloride.

The potassium chloride pellet and the desensitized T.N.T. composite pellets at the forward end of the shell cavity are apparently used instead of the usual pitch pad or wooden block to deaden the H.E. filling at this point and so prevent premature functioning on impact.

Gaine and Fuze

The gaine is carried in the steel exploder container and is the Zdlg. C/98 filled picric acid.

The base fuze is of the optional delay type and is provided with a setting plug and has setting graduations stamped in the underside.

ITALIAN H.E. HAND GRENADE, S.R.C.M. Model 35

(Fig. 23)

The grenade is of the percussion type with an "Always" action. The cylindrical body with a screwthread around the centre is painted red and is fitted with an unpainted safety cover of aluminium which fits over one end and extends over a portion of the side. The head of the safety cover is embossed "SOCIETA ROMANA". The grenade is approximately 3.2 inches long, 2 inches in diameter and weighs 6 oz. 10 dr. A paper wrapper, in which the grenade is packed, bears the printing "SOCIETA ROMANA COSTRUZIONI MECCANICHE".

The body of the grenade is of tinned plate and consists of two cup-shaped portions with a pressed screwthread at the mouth for assembly and a recess at the closed end, which forms part of the arrangement to obtain "Always" action. When screwed together the cups are secured by a locking wire which is located on the inside of the pressed threads in the base cup and is bent to form a projection which passes through coinciding holes in both cups and protrudes slightly from the exterior of the assembled body. The upper cup carries a stud near the periphery of the head and has slots in the wall for the insertion of the safety strip and safety bar. The stud is used as a means of coiling a length of light chain which connects the safety cap to the safety bar.

A steel collar is located in the recess inside the head and base of the body. The collars are seated in similar recesses in the charge container and outer container, for which they form the end supports.

The outer container is of tinned plate and is in the form of an inverted cup which carries a needle inside at the closed end and fits over the charge container. A spiral spring is held between the upper end of the outer container and a bearing plate. The bearing plate has a central hole for the needle and is supported by a shutter device when the grenade is armed. The shutter device consists of a tinned plate arm pivoted at one end on a pin which is fixed in an aperture in the wall of the outer container, whilst the other end protrudes through another aperture on the opposite side of the container. The protruding end is held in engagement with an inclined undercut on a projection formed in the aperture by a spiral spring. The spring extends around the outside of the

ITALIAN H.E. HAND GRENADE S.R.C.M. MODEL 35.

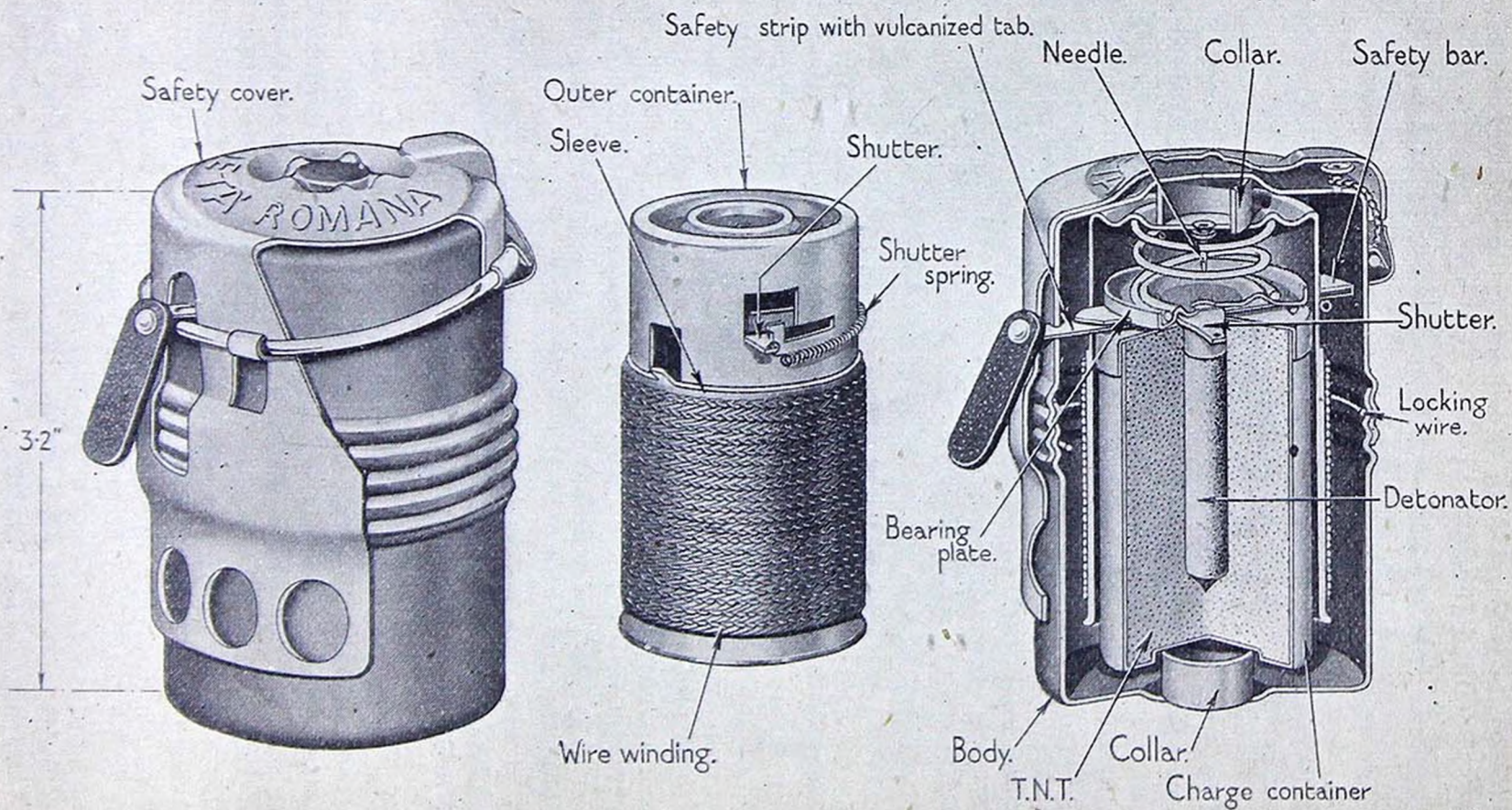

FIG. 23

container, between the two apertures, and is tensioned between the protruding end of the shutter and the pivot pin. The aperture in which the undercut projection is formed also has a slot through which the protruding end of the shutter is moved, by the spring, when freed from the undercut. The shutter is a thin, flat plate tapering from the centre towards the ends. A hole, eccentrically placed at its widest part, is not coincident with the needle hole in the bearing plate when the shutter is held by the undercut projection. Two additional apertures are formed diametrically opposite in the wall of the outer container, at right angles to those for the shutter, to receive the safety bar and the safety strip. The bar extends diametrically through the outer container between the bearing plate and the shutter and is bent at the outer end to fit over the ring of the safety cover. The bar is attached to the ring by a 2.5-inch length of light chain. The safety strip is of thin brass and extends diametrically through outer container and the body of the grenade between the shutter and the head of the charge container. A vulcanized gripping tab is attached to one end of the strip which passes over the cover ring. The other end of the strip emerges below the ring and is bent upwards over the ring and the safety bar. A steel sleeve, wound with wire, is fitted externally to the outer container to provide fragments for destructive effect and the weight necessary for "Always" action.

The cylindrical charge container is of tinned plate and has a 1.5-oz. filling of T.N.T. with a central detonator. The percussion cap at the head of the detonator protrudes through a central hole in the closing cap of the container.

The safety cover is shaped to fit over the head and down one side of the grenade. The cover carries an encircling ring secured in an inclined position by bent tongues formed in the cover. The cover is retained on the grenade by the safety strip and bar engaging the ring to which the chain of the safety bar is also attached.

Action

Before throwing the grenade the safety strip is removed by pulling the vulcanized tab. The withdrawal of the strip releases the ring of the safety cover. During flight the cover leaves the grenade and, functioning as a drogue, extends the chain and withdraws the safety bar. The charge container with its detonator is then held off the needle in the head of the outer container only by the intervening spiral spring and the shutter. On impact the charge container is forced further into the outer container. The manner in which this movement is brought about depends upon the position of the grenade on impact. With a head-on strike the charge container is carried into the outer container by momentum. With a base strike the outer container, weighted

with its steel sleeve and wire winding, is carried down over the charge container by momentum. With side impact the collars engaging in the recesses at the head and the base of the containers are tilted by the side thrust and thus cause a telescopic movement of the containers. The entry of the charge container forces the shutter clear of the undercut projection, and as it is turned on its pivot by the tension spring, the hole in the shutter coincides with the hole in the bearing plate. Whilst in this position the spiral spring is further compressed and the needle pierces the detonator. Unless the grenade is thrown with considerable force the shutter will not be released on impact and the grenade will fail to function.

ITALIAN 75/27 HOLLOW CHARGE STREAMLINED SHELL WITH INTERNAL BASE FUZE

(Fig. 24)

The shell is fired from the separate-loading Q.F. 75 mm. 27 calibre field gun. The streamlined body of the shell has a narrow driving band of copper and is fitted with a dome-shaped impact cap. The body is coloured the normal pale blue with a white band immediately above the driving band. The impact cap is bright red. The designation of the equipment, "75/27", and the nature of the bursting charge, "TRITOLITE", are stencilled in dark blue on the body. The length of the shell is 10 inches and the weight, filled, is 10 lb. 3 oz.

Shell

The shell body is of forged steel with a mild steel plate pressed in at the base and a left-hand external screwthread at the head to receive the impact cap. The cavity for the bursting charge is increased in diameter near the head and has a steel adapter for the fuze sweated with solder near the base. The impact cap is of aluminium alloy and is stepped internally to engage the flange on the cavity liner.

The cavity liner is pressed from 1 mm. mild steel plate and is roughly parabolic in shape.

The weight of the shell without fuze and filling is 8.57 lb.

Bursting Charge and Exploder

The bursting charge weighs 1 lb. 0 oz. 6 dr. and consists of cyclonite/T.N.T./wax, the percentage of each being 58, 40.5 and 1.5 respectively. The filling is cast with the fuze and exploder assembled in the cavity.

The exploder consists of approximately 656 grains of cyclonite/wax, 95/5, in the form of two pellets in a paper wrapper. The

upper pellet is solid, whilst the lower has a cavity in the base to fit over the gaine fitted to the fuze. An aluminium sheath, shaped to fit round the pellet and form a liner for the gaine cavity, is fitted over the base end of the lower pellet.

Fuze

The fuze is screwed into the adapter in the base of the shell cavity with a left-hand screwthread and is fitted with a gaine which enters the cavity in the exploder. Details of the fuze and gaine are not yet available.

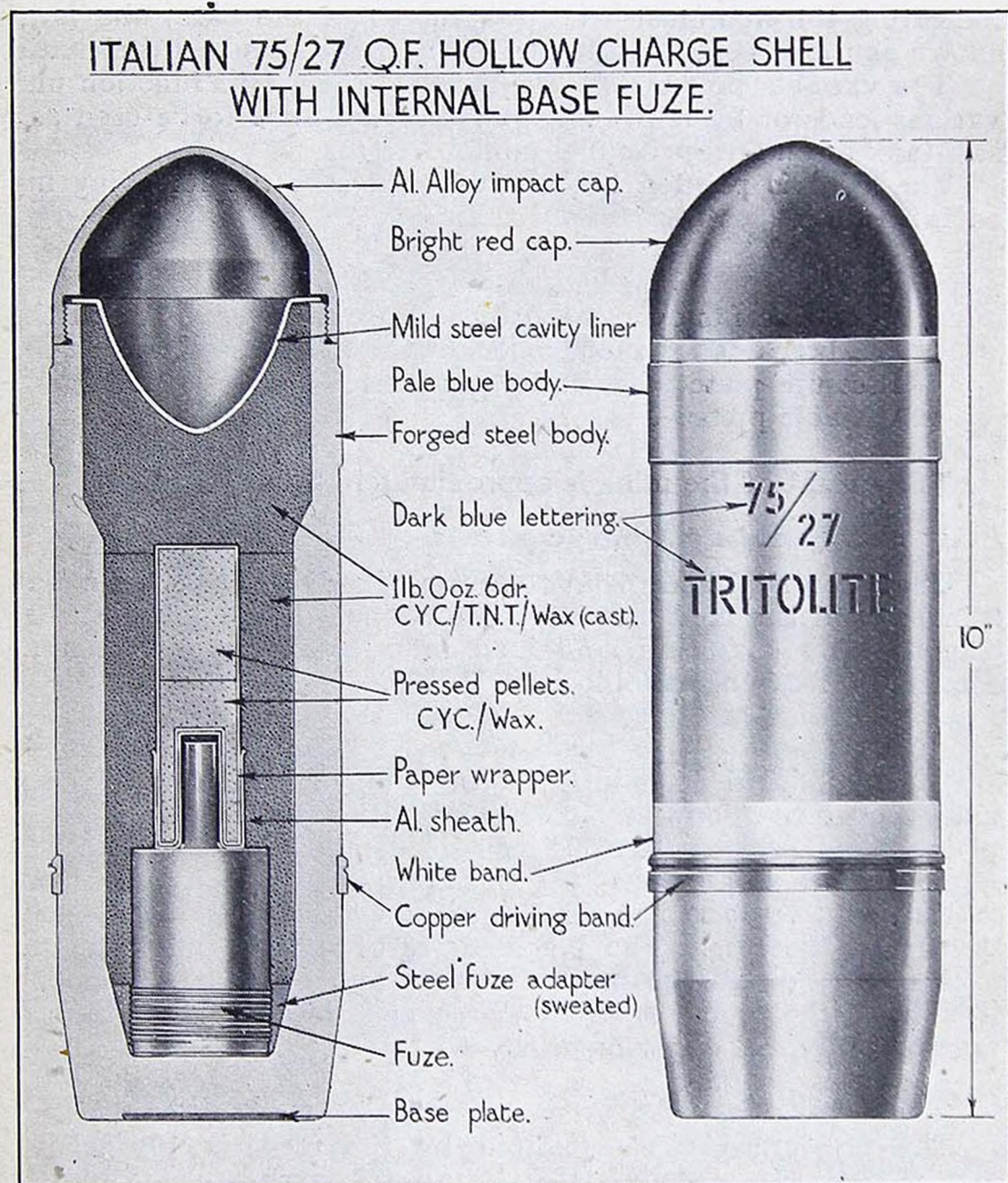

FIG. 24

Perforation of Armour

The perforation performance against homogeneous armour plate is estimated to be 55 mm. at the normal and 50 mm. at 30 degrees to the normal.

HUNGARIAN MINE WITH VARIABLE PRESSURE FUZE

(Fig. 25)

The mine, which is used by the Germans and probably by the Italians also, has been referred to as the C.R.T. type (these letters indicating the manufacturer are stamped in the base) and is also known as the C.V.P.1. The latter is now the standard designation.

The variable pressure fuze, which can be set to function under various loads or by trip action, enables the mine to be used as an anti-tank or an anti-personnel mine.

The mine is painted black and consists of the following main parts:—

Body with 3.5 lb. filling of cast T.N.T.

Lid which fits over the body with fuze-hole socket and three brackets for the spindles of the pressure plate.

Pressure plate with three spindles.

Variable pressure fuze.

The weight of the mine is approximately 8 lb.

Body and Bursting Charge

The cylindrical body is in the form of a dish with a diameter of 8 inches and is a cold pressing from .03-inch dead mild steel sheet. The bursting charge is contained in a black paper carton and consists of a 3.5-lb. cast block of T.N.T.

Lid

The cylindrical lid is in the form of an inverted dish which fits closely over the body and carries both the fuze and the pressure plate. Cold pressed from .04-inch dead mild steel sheet, it has a screwthreaded brass fuze-hole bush sweated into a hole in the centre at the top and has three equally spaced right-angle brackets welded to the side. The brackets are of .12-inch mild steel and each has a hole in the horizontal arm to receive a corresponding spindle on the pressure plate. A socket is formed below the fuze-hole to receive an exploder pellet.

Pressure Plate

The pressure plate, supported by the fuze, is 10 inches in diameter, slightly domed and is stamped from hot-rolled mild steel .12-inch sheet. Three equally spaced mild steel spindles of .4-inch

HUNGARIAN MINE WITH VARIABLE PRESSURE FUZE.

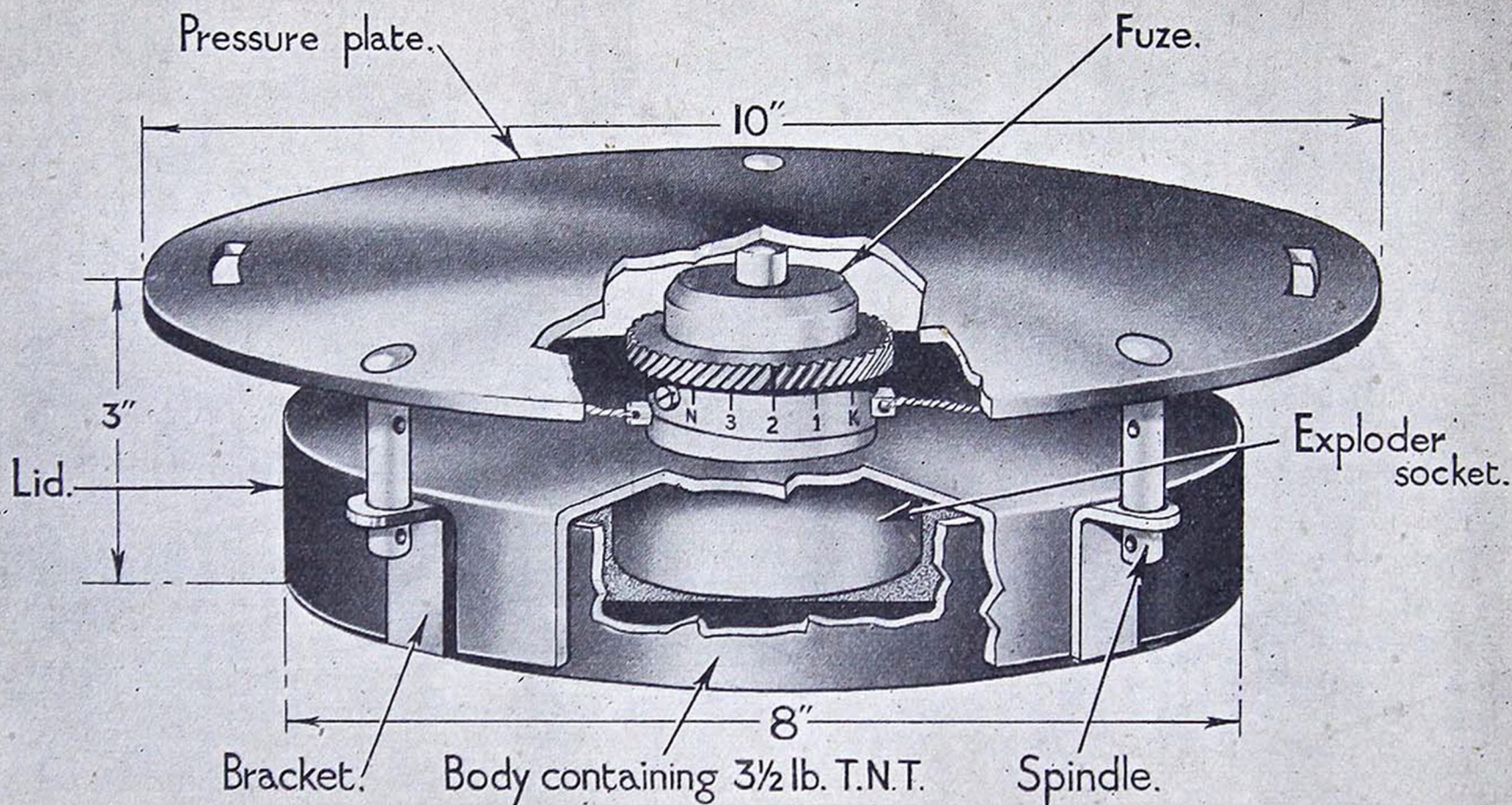

FIG. 25

diameter are welded into holes near the periphery of the plate and project downwards. Two holes, about 1 inch apart, are formed in the spindles to receive a pin when the spindles are inserted through the brackets on the lid. The pins are inserted in the upper holes, below the brackets, when the mine is plugged and packed and in the lower holes when fuzed ready for use. Two rectangular slots are formed in the pressure plate, diametrically opposite, to receive a tie arrangement used in packing.

Fuze (Fig. 26)

The fuze is mainly of brass and consists of a cylindrical body with a graduated flange and a milled setting ring around its approximate centre, below which a brass safety bolt protrudes from one side and a steel shearing blade from the other. A small magazine is screwed to the base of the fuze and a brass cylindrical striker protrudes from the centre of the top.

The fuze is designed so that the needle is held off the detonator by a steel shearing blade which engages a tapered flange on the needle holder. When the requisite load is applied to the striker the flange is cut by the blade and the needle pierces the detonator. The load required depends upon the extent to which the blade is engaging the needle holder, and this can be varied by the setting ring. The fuze can also be used as a trip mechanism by setting so that there is no obstruction to the withdrawal of the shearing blade by a connected trip wire.

The brass body has a flange or platform formed around its centre, which has a circular groove of square section in its upper face to receive the setting ring and is graduated around the periphery for setting. A groove is also formed in the periphery to receive a length of cord attached to the safety bolt. The lower part of the body is screwthreaded externally for insertion in the lid of the mine and internally to receive the detonator plug. The upper part is screwthreaded externally to receive the brass cap which retains the striker. A large recess in the body contains the needle holder and has two radial channels near the base for the safety bolt and shearing blade.

The brass striker is in the form of a plunger which protrudes through the cap and is supported by a steel spiral spring held in compression between the needle holder and an external flange on the striker.

The brass needle holder is cup-shaped to receive the striker and spring and has a tapered flange around its base. The steel needle is fitted in its base, which is recessed to engage a flange on the inner end of the safety bolt if the holder is not supported by the shearing blade.

The brass safety bolt is located below the level of the shearing blade, and the flange at its inner end does not engage the recess in the base of the needle holder unless the blade is not supporting the

VARIABLE PRESSURE FUZE & TRIP MECHANISM FOR HUNGARIAN MINE.

65
FIG. 26

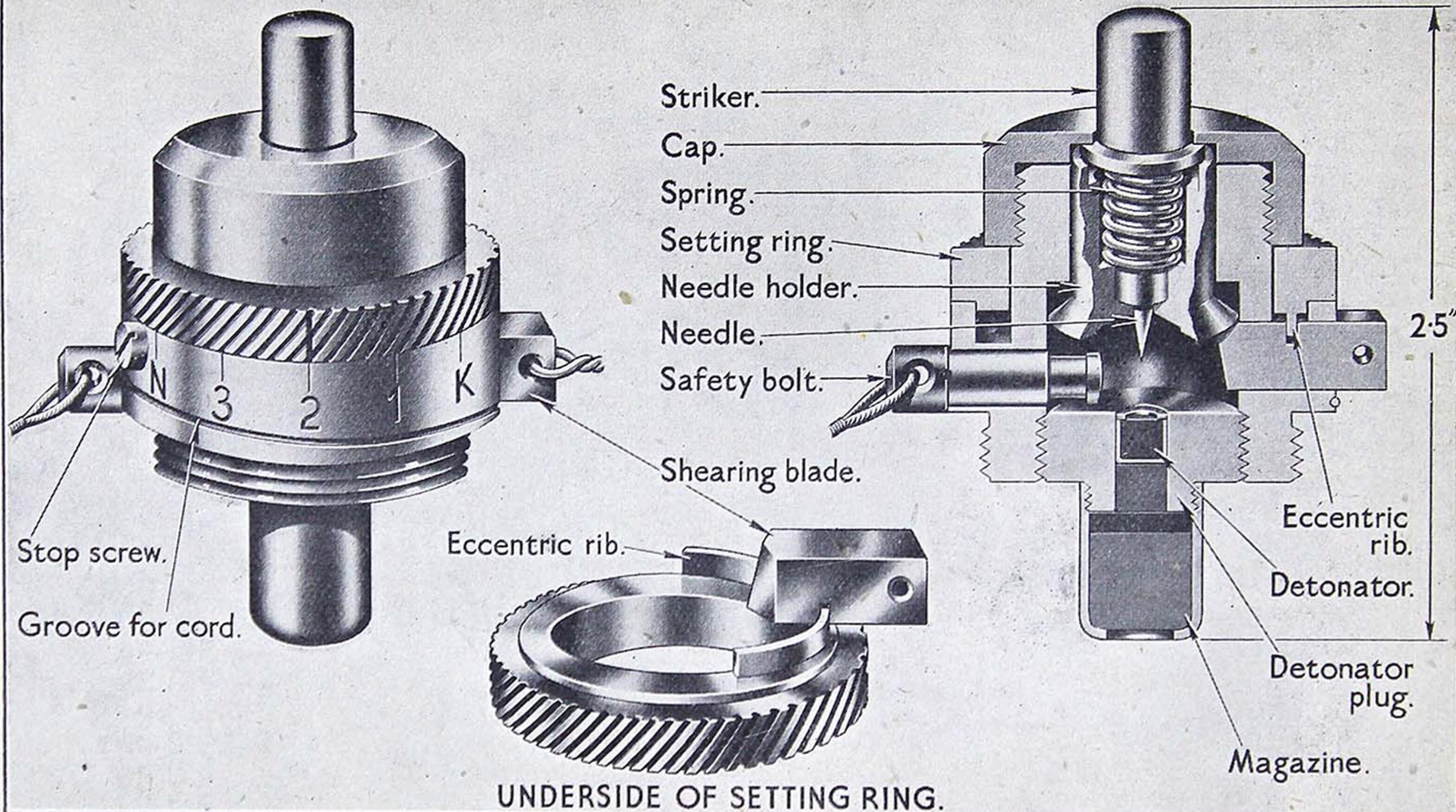

holder. When engaged by the holder the bolt cannot be withdrawn. A 3-foot length of cord is attached to an eye in the outer end of the bolt and is secured round a groove in the graduated flange on the body.

The shearing blade is of hardened and high-tempered carbon steel and is shaped as a cutting tool. An eye is formed in its outer end for the attachment of a trip wire, and a groove in its upper face is cut to the same pitch as the rib on the underside of the setting ring, with which it engages.

The brass setting ring fits round the body, where it is retained between the graduated flange and the cap. The exterior is milled to facilitate turning and has a setting index in the form of a red vertical line. The underside of the ring is stepped to enter the groove in the flange. A rib, extending eccentrically over a portion of the base of the ring, protrudes through a slot in the groove and engages the groove in the upper face of the shearing blade.

Action

The mine is transported with a wooden plug in the fuze-hole, the fuze being set and inserted when required for use. The pressure plate is then fitted to the mine and the safety bolt withdrawn by its cord. The turning of the setting ring causes the eccentric rib on its underside to impart a lateral movement to the shearing blade, thereby determining the load required to result in the shearing of the tapered flange on the needle holder.

When the requisite load is applied to the pressure plate the striker is pushed down against its spring and the stress is taken by the needle holder. This results in the shearing of the tapered flange on the holder and the needle pierces the detonator.

The loads required to function the fuze at the various settings are as follows:—

| <i>Setting</i> | | | | | <i>Load</i> |
|----------------|-----|-----|-----|-----|-------------|
| K | ... | ... | ... | ... | 77 lb. |
| 1 | ... | ... | ... | ... | 220 lb. |
| 2 | ... | ... | ... | ... | 440 lb. |
| 3 | ... | ... | ... | ... | 660 lb. |
| N | ... | ... | ... | ... | 770 lb. |

The H setting is used when the fuze is required to function as a trip mechanism when the stop screw, adjacent to the safety bolt, in the graduated flange has been removed. With the screw removed and the setting ring turned to the H setting, the eccentric rib is disengaged from the groove in the shearing blade. The blade is then free to be withdrawn by a trip wire attached to its outer end.

INDEX

Pamphlets No. 1 to No. 8 inclusive

| | <i>Pamphlet No.</i> | | <i>Pamphlet No.</i> |
|------------------------------|-------------------------|-------------------------------|-------------------------|
| GERMAN | | | |
| SMALL ARMS AMMUNITION | | | |
| 7.92 mm. Mauser:— | | | |
| A.P. | 2 and 5 | H.E. fuzed | A.Z. |
| A.P./T. | 2 and 5 | 1502 | 3 and 5 |
| A.P./I. | 5 | H.E. fuzed S.D. | A.Z. |
| Ball | 2 and 5 | 1505 | 3 and 5 |
| Explosive/Incendiary ... | 5 | H.E./I./T. (S.D.) fuzed | |
| H.V.A.P. | 5 | A.Z. 1504 | 5 |
| H.V.A.P./T. | 5 | H.E./I. fuzed S.D., | |
| H.V.A.P./I. | 5 | Z.Z. 1505 | 3 and 5 |
| H.V.A.P. (T.C. Core) ... | 5 | Primer, electric | 5 |
| Practice Ball | 5 | Solothurn Cartridges:— | |
| Practice Tracer | 5 | A.P./I./T. | 5 |
| S.A.P. | 5 | A.P./Sulphur/T. | 5 |
| 7.92/13 mm. Pz. B.38/39:— | | | |
| A.P./Lachrymatory ... | 4 | A.P./T. | 5 |
| 9 mm. Pistol:— | | | |
| Ball '08 | 5 | A.P./T. (T.C. core) ... | 5 |
| S.A.P. | 5 | H.E./T. (S.D.) fuzed | |
| 13 mm. to 30 mm. Weapons:— | | | |
| Marking of Ammunition... | 5 | A.Z. 5045 | 5 |
| 2 cm.:— | | | |
| Oerlikon, Mauser and | | H.E./T (S.D.) stream- | |
| Solothurn types... .. | 5 | lined, fuzed A.Z. 5045 | 5 |
| Oerlikon Cartridges:— | | H.E./I./T. (S.D.) | |
| A.P. Shot | 5 | streamlined, fuzed | |
| Ball | 5 | A.Z. 5045 | 5 |
| H.E. fuzed A.Z. 1502 | | 2.8 cm. Pz.B.41:— | |
| or S.D. fuze Z.Z. | | Cartridge A.P. (T.C. core) | |
| 1505 | 3 | 4 | |
| H.E./T. (S.D.) fuzed | | Fuzes | |
| A.Z. 1501 | 5 | A.Z. 1501 | 5 |
| H.E./T. (S.D.) fuzed | | A.Z. 1502 | 1 |
| A.Z. 5045 | 5 | A.Z. 1504 | 5 |
| H.E./T. (S.D.) fuzed | | Z.Z. 1505 | 5 |
| A.Z. 1504 | 5 | A.Z. 5045 | 5 |
| H.E./I./T. (S.D.) fuzed | | Oerlikon A.A. | 1 |
| A.Z. 1504 | 5 | GRENADES | |
| Tracer | 5 | Egg, H.E., hand grenade | |
| Mauser Cartridges:— | | | |
| A.P. Shot | 5 | 5 and 6 | |
| A.P./H.E. | 5 | Stick, H.E., hand grenade ... | |
| A.P./I. | 5 | 5 | |
| | | H.E. rifle and hand grenade | |
| | | 6 | |
| | | H.E. anti-tank rifle grenade | |
| | | 6 | |
| | | (Hollow charge) | |
| | | 6 | |
| | | Smoke, hand grenade | |
| | | 1 | |
| | | MORTAR AMMUNITION | |
| | | 5 cm. H.E. bomb 36 fuzed | |
| | | 4 | |
| | | Wgr. Z.38 with cartridge | |
| | | 4 | |
| | | 8 cm. H.E. bomb 34 fuzed | |
| | | 6 | |
| | | Wgr. Z.38 with cartridges | |
| | | 1 | |
| | | Fuze L.M.W. Z.23 | |

| | <i>Pamphlet</i> No. |
|--|------------------------|
| GUN AND HOWITZER AMMUNITION | |
| Marking and nomenclature | 6 |
| Cartridges and Shell | |
| 3.7 cm. Skoda, A.P.C. shell and fuze | 2 |
| 3.7 cm. Pak:— | |
| Ctge., Q.F., A.P. Shot 40 (T.C. core) | 4 |
| Ctge., Q.F., H.E./T. fuzed A.Z.39 or Kpf. Z.Zerl P. | 6 |
| Ctge., Q.F., A.P. fuzed Bd.Z. 5103, or 5103*, with tracer | 7 |
| 4.7 cm. Pak (t):— | |
| A.P. shell with tracer fuze | 4 |
| A.P. shot, 40 (T.C. core) | 4 |
| H.E. shell with fuze ... | 4 |
| 5 cm. Pak 38:— | |
| Ctge., Q.F., H.E. fuzed A.Z.39 | 4 |
| Ctge., Q.F., A.P. Shot 40 (T.C. core) | 6 |
| A.P. shell fuzed Bd.Z. 5103*, with tracer ... | 4 |
| 5 cm. Kw.K:— | |
| A.P. shell fuzed Bd.Z. 5103* with tracer ... | 4 |
| A.P.C. shell fuzed Bd.Z. 5103* with tracer ... | 8 |
| A.P. Shot, 40 (T.C. core) | 6 |
| 7.5 cm. Pak 40:— | |
| Ctge., Q.F., A.P.C.B.C. 39, fuzed Bd.Z.5103* with tracer | 7 and 8 |
| Ctge., Q.F., H.E., 34, fuzed Kl. A.Z.23 | 7 |
| 7.5 cm. Kw.K and Stu. G. 7.5 cm. K.:— | |
| A.P.C.B.C. shell fuzed Bd. Z. 7.5 cm. with tracer | 4 |
| Smoke shell fuzed Kl. A.Z.23 Nb | 4 |
| Ctge., Q.F., Hollow charge, 38, fuzed A.Z. 38 | 8 |

| | <i>Pamphlet</i> No. |
|--|------------------------|
| Ctge., Q.F., H.E. fuzed Kl. A.Z.23 | 4 |
| 7.5 cm. Kw.K 40 and 7.5 cm. Stu. K.40:— | |
| Ctge., Q.F., H.E., 34 fuzed Kl. A.Z. 23 | 7 |
| Ctge., Q.F., A.P.C.B.C., 39, fuzed Bd.Z.5103* with tracer | 7 and 8 |
| 7.5 cm. l.I.G. 18:— | |
| H.E. shell fuzed l. Igr. Z.23nA. | 1 and 8 |
| H.E./Al. shell fuzed l. Igr. Z.23nA. | 8 |
| 7.5 cm. L.G.40:— | |
| Q.F. cartridge | 8 |
| Hollow charge stream- lined shell, 38, fuzed A.Z.38 | 8 |
| 7.62 cm. F.K. 296 (r) or Pak 36 (r):— | |
| Ctge., Q.F., H.E. with D.A./G r a z e fuze (Russian origin) | 8 |
| Ctge., Q.F., A.P.C.B.C., 39, fuzed Bd.Z. 7.5 cm, with tracer. | 6 |
| Ctge., Q.F., A.P.B.C. shot, 40, (T.C. core) | 6 |
| 8 cm. L.K., M.30:— | |
| H.E. shell, M.30 with C.H.Z.R. fuze (Czech origin) | 3 |
| 8.8 cm. Flak 36:— | |
| H.E. shell fuzed A.Z.23 or Zt.Z. S/30 | 1 |
| Ctge., Q.F., H.E. fuzed A.Z.23/28 or Zt. Z.S./30 | 6 |
| Ctge., Q.F., A.P.C.B.C. fuzed Bd.Z. 8.8 cm. with tracer | 6 |
| s. 10 cm. K.18 (10.5 cm. calibre):— | |
| H.E. streamlined shell fuzed A.Z.23 | 1 |
| A.P.C.B.C. shell fuzed Bd.Z. 10 cm. with tracer | 6 |
| 10.5 cm l.F.H. 18:— | |
| Q.F. cartridge and super charge | 7 |

| | <i>Pamphlet</i> No. |
|--|------------------------|
| A.P.C.B.C. shell fuzed Bd.Z. 10 cm. with tracer | 6 |
| A.P. shell fuzed Bd.Z. 10 cm. with tracer ... | 6 |
| H.E., streamlined shell fuzed A.Z.23 ... | 1 |
| Smoke streamlined shell fuzed Kl. A.Z.23 Nb | 6 |
| Hollow charge shell 39 rot Hl. | 8 |
| 15 cm.s.F.H. 18:— | |
| Q.F. cartridge and super charges ... | 8 |
| H.E. streamlined shell fuzed A.Z.23 ... | 1 |
| Anti-concrete shell 19 fuzed Bd.Z. 15 cm.... | 8 |
| 21 cm. Mrs. 18:— | |
| Q.F. cartridge and super charge | 8 |
| Anti-concrete shell fuzed Bd.Z. 21 cm. ... | 8 |
| Fuzes | |
| Nose V.Z.21n | 1 |
| V.Z.25 | 1 |
| A.Z.23 (0.25) | 1 |
| A.Z.23 (0.8) | 1 |
| A.Z.23/28 (0.2) | 6 |
| l.Igr (or Jgr) Z. 23nA | 1 and 8 |
| Kl.A.Z.23 | 7 |
| Kl.A.Z.23 Nb. | 4 |
| Zt.Z.S/30 | 6 and 8 |
| Zt. Z.S/30Fg ¹ | 8 |
| A.Z. 38 | 8 |
| A.Z. 39 | 4 |
| Dopp. Z. S/60 | 1 |
| Dopp. Z. S/90 | 4 |
| 3.7 cm. Kpf. Z. Zerl P. | 8 |
| 4.7 cm. | 4 |
| 7.62 cm. D.A./Graze (Russian) | 8 |
| S.K.H.Z.R. (Skoda) | 1 |
| C.H.Z.R. (Skoda) ... | 3 |
| Base Bd. Z. 7.5 cm. Pzgr. | 4 |
| Bd. Z. 8.8 cm. Pzgr | 6 |
| Bd. Z. 10 cm. Pzgr. | 6 |
| Bd. Z. 5103 | 7 |

| | <i>Pamphlet</i> No. |
|--|------------------------|
| Bd. Z. 5103* (5 cm. A.P.) | 4 |
| m.V.u.K. | 4 |
| B.Z. 15 - 28 - 39 (Skoda) | 2 |
| Gaines | |
| Zdlg. A | 6 |
| Zdlg. B | 6 |
| Zdlg. Kz C/98 | 6 |
| Zdlg. Gr C/98 | 6 |
| Zdlg. 40 | 8 |
| Primers, Q.F. Cartridge | |
| C/12 percussion | 4 |
| C/13 percussion | 7 |
| C/22 electric | 4 |
| C/33 percussion | 7 |
| Percussion of Russian origin | 6 |
| Tracers | |
| Base fuze types | 6 |
| DEMOLITION STORES AND MINES | |
| 12.5 Kg. Hollow charge ... | 5 |
| 50 Kg. Hollow charge ... | 5 |
| Detonators No. 8 types T. and R. | 6 |
| Tellermine 35 | 8 |
| Fuze T. Mi. Z35 | 8 |
| Pull igniter Z.Z.35 | 8 |
| AIRCRAFT BOMBS | |
| 1 Kg. Incendiary bomb ... | 1 |
| 1 Kg. H.E./Incendiary bomb | 3 |
| Collapsible container for in- cendiary bombs | 3 |
| 2 Kg. Anti-personnel bomb S.D.2 (Butterfly bomb) ... | 3 |
| Anti-withdrawal device for bomb fuze, ZUS 40 | 3 |
| PYROTECHNICS | |
| Flare picket | 3 |
| HUNGARIAN | |
| Anti-tank and anti-personnel mine with variable pressure fuze | 8 |

ITALIAN

SMALL ARMS AMMUNITION

| | |
|----------------------------|---|
| 7.7 mm. Breda:— | |
| A.P./I Blue tipped bullet | 3 |
| A.P./I Green tipped bullet | 3 |
| 12.7 mm. Breda:— | |
| A.P./I. T. Bullet... | 3 |
| I./T. Bullet | 3 |

GRENADES

| | |
|-----------------------------|---|
| H.E. hand grenade, Breda | |
| Model 35 | 4 |
| H.E. hand grenade, S.R.C.M. | |
| Model 35 | 8 |

MORTAR AMMUNITION

| | |
|--------------------------|---|
| 45 mm. Brixia H.E. bomb, | |
| Model 35 | 4 |

**GUN AND HOWITZER
AMMUNITION**

| | |
|--|---|
| Markings on A.P., H.E., hollow charge and shrapnel shell | 7 |
| Cartridges and Shell | |
| 47/32 A/TK Gun 35:— | |
| Ctge., Q.F., H.E. with fuze | 7 |
| Ctge., Q.F., A.P. with tracer fuze | 7 |
| Ctge., Q.F., A.P.B.C. with tracer fuze | 7 |
| 65/17 Inf. gun:— | |
| Ctge., Q.F., H.E. with fuze | 7 |
| 75/13 How.:— | |
| Q.F. cartridge | 7 |
| H.E. shell | 7 |
| 75/27 Gun-how.:— | |
| Q.F. cartridge | 7 |
| H.E. streamlined shell, 32 | 7 |
| Hollow charge shell | 8 |
| 100/17 How.:— | |
| Q.F. cartridge | 7 |
| H.E. streamlined shell | 7 |
| Hollow charge shell with internal base fuze | 7 |

Fuzes

| | |
|---|---|
| D.A./graze fuze with escapement mechanism, model 16 | 4 |
| D.A./graze fuze with escapement mechanism | 7 |
| D.A./graze fuze used in 47/32 H.E. shell | 7 |
| Inneschi graze fuze | 7 |
| Time fuze graduated to 13.2 | 7 |
| Time fuze graduated to 160 | 7 |
| 47/32 base tracer fuze | 7 |
| 100/17 base fuze | 7 |
| Caines | |
| .89 gram cyclonite gaine | 7 |
| 1.8 gram cyclonite gaine | 7 |
| 2.3 gram ballistite gaine | 7 |
| Primers, Q.F. Cartridge | |
| Model 35 percussion | 7 |

AIRCRAFT BOMBS

| | |
|--|---|
| Fuze for the destruction of abandoned aircraft | 3 |
| H.E. anti-personnel bomb (Spezzone) | 3 |
| H.E. anti-disturbance bomb 4 A.R. (Manzolini thermos type) | 3 |

JAPANESE

GRENADES

| | |
|---------------------------------|---|
| H.E. hand grenade | 6 |
| H.E. hand and mortar grenade | 6 |

MORTAR AMMUNITION

| | |
|--|---|
| 50 mm. mortar and hand H.E. grenade | 6 |
| 50 mm. rifled mortar H.E. round | 6 |

**GUN AND HOWITZER
AMMUNITION**

| | |
|--------------------|---|
| 7 cm. H.E. shell | 6 |
| 7.5 cm. H.E. shell | 6 |
| D.A. nose fuze | 6 |