

Confidential

HANDBOOK OF AIRCRAFT ARMAMENT



U.S. BUREAU OF AIRCRAFT PRODUCTION
AIR SERVICE, U. S. ARMY

AUGUST, 1918



WASHINGTON
GOVERNMENT PRINTING OFFICE
1918

C. E. 2.

CONTENTS.

	Page.
Preface.....	5
Section A:	
List of reference books.....	7
Conversion tables.....	8
Section B—Machine guns:	
Marlin aircraft machine gun.....	17
Lewis aircraft machine gun.....	25
Vickers aircraft machine gun.....	35
11 m/m Vickers aircraft machine gun.....	42
Mounting on aircraft—Precautions before and after flights, am- munition, etc.....	10
Tools to be supplied with armorer's chest.....	13
Tools to be supplied with armorer's truck.....	14
Metallic disintegrating link belts.....	42
Section C—Machine gun mounts:	
Fixed mounts.....	46
Flexible mounts.....	47
Single Lewis gun yoke.....	49
Double Lewis gun yoke.....	52
Lewis magazine racks.....	53
Section D—Synchronizing gears:	
Hydraulic or C. C. synchronizing gear.....	55
Mechanical synchronizing gear.....	56
Section E—Machine gun sights:	
Theory of ring and post sights.....	60
Auxiliary sight.....	61
Ring and wind vane sight.....	61
Unit sight.....	63
Sight mountings.....	65
Section F—Bombs:	
High capacity drop bombs.....	66
Fragmentation bombs.....	69
Incendiary bombs.....	71
Dummy bomb, Mark I.....	73
Marking of bombs.....	73
Packing of bombs.....	74
Storage of bombs.....	74
Section G—Bomb-release mechanism:	
List of bomb-release mechanisms.....	75
Mark V bomb-release mechanisms.....	78
Section H—Theory of bomb sighting:	
Mark I—A bomb sight.....	81

	Page.
Section I—Aircraft ammunition:	
Armor piercing.....	83
Tracer.....	83
Incendiary.....	83
Armor-piercing incendiary.....	84
Armor-piercing tracer.....	84
Storage of incendiary ammunition.....	84
Packing of aircraft ammunition.....	84
Cartridge gauges.....	85
Section J—Pyrotechnics:	
35 mm. pistol aviation, Mark, I.....	61
Airplane flare, Mark I.....	88
Wing-tip flare, Mark I.....	89
Section K—Small arms:	
Browning machine rifle.....	92
Winchester rifle, caliber .351.....	93
Colt, and Smith & Wesson revolvers.....	93

PREFACE.

In compiling this Handbook of Armament as used on aircraft, no attempt has been made to treat the various subjects in an exhaustive technical manner. Full data of this description can be obtained from the various reference books issued by the War Department, of which there is a list embodied in this book.

The principal idea has been to acquaint all interested, with the correct nomenclature in particular, and with the appearance, fundamental ideas, and theories relative to all articles of armament pertaining to airplanes as produced by the United States.

Owing to the various additions and improvements which must necessarily occur in the armament of aircraft due to new ideas and methods of aerial warfare, this book is prepared in loose-leaf form in order that any additions or changes may be facilitated.

E. T. BRADLEY,
Major, A. S. A. P.

HANDBOOK OF AIRCRAFT ARMAMENT.

SECTION A.

LIST OF REFERENCE BOOKS.

The handbooks listed below are issued by the War Department, and may be obtained upon request:

MACHINE GUNS AND SMALL ARMS.

- No. 1866. Automatic Pistol, Caliber .45.
- No. —. Browning Aircraft Machine Gun, Model of 1918.
- No. 1937. Browning Machine Gun, Model of 1917.
- No. 1934. Browning Machine Rifle, Model of 1918.
- No. 1932. Hotchkiss Machine Gun, Model of 1914.
- No. —. Lewis Aircraft Machine Gun, Model of 1917.
- No. 1931. Lewis Machine Gun, Model of 1917.
- No. 1933. Marlin Aircraft Machine Gun, Model of 1917.
- No. 1923. United States Rifle, Model of 1903.

BOMBS AND BOMB-RELEASE MECHANISMS.

- No. 742. Barlow Heavy Drop Bomb and Release Mechanism.
- No. 717. Dummy Drop Bomb, Mark I.
- No. —. Fragmentation Bombs, Marks I, II, and III.
- No. 724. High Capacity Drop Bombs, Marks I, II, and III.
- No. —. High Capacity Drop Bombs, Marks IV, V, and VI.
- No. 777. Incendiary Drop Bombs, Marks I and II.
- No. —. Smoke Drop Bombs, Marks I, II, and III.
- No. —. Release Mechanism, Mark V.
- No. —. Release Mechanism, Mark VII, A and B.

BOMB SIGHTS.

- No. 741. Bomb Sight, Mark I.
- No. —. Bomb Sight, Mark I-A.
- No. —. Synchronizing Bomb Sight.

MISCELLANEOUS.

- No. —. Airplane Flares, Mark I, and Airplane Signals.
- No. —. Military Explosives.
- No. 739. Very Pistol, Mark III, and Signal Light, Mark II.
- No. 752. Smoke Torch, Mark I.
- No. 751. Signal Light, Mark I, and Rifle Light, Mark I.
- No. 722. Position Lights, Marks I and II.

CONVERSION TABLES.

WEIGHT.

1 metric ton.....	2,204.6 pounds (avoir.).
1 kilogram.....	2.2046 pounds (avoir.).
1 gram.....	0.03527 ounce (avoir.).
1 ton.....	1,016 kilograms.
1 pound.....	0.4536 kilogram.
1 ounce.....	28.35 grams.

LINEAR MEASURE.

1 kilometer.....	0.6214 mile.
1 meter.....	39.39 inches.
1 centimeter.....	0.3937 inch.
1 millimeter.....	0.03937 inch.
1 mile.....	1.609 kilometers.
1 yard.....	0.9144 meter.
1 foot.....	0.3048 meter.
1 inch.....	2.54 centimeters.

SQUARE MEASURE.

1 square kilometer.....	0.3861 square mile.
1 square meter.....	10.76 square feet.
1 square centimeter.....	0.1550 square inch.
1 square mile.....	2.590 square kilometers.
1 square foot.....	0.0929 square meter.
1 square inch.....	6.452 square centimeters.

CUBIC MEASURE.

1 cubic meter.....	35.314 cubic feet.
1 cubic centimeter.....	0.0610 cubic inch.
1 cubic foot.....	0.02832 cubic meter.
1 cubic inch.....	16.387 cubic centimeters.

CAPACITY.

1 gallon.....	3.785 liters.
1 cubic foot.....	28.317 liters.
1 liter.....	61.023 cubic inches.
1 liter.....	2.20 pounds water.

MISCELLANEOUS.

1 pound (avoir.).....	7,000 grains.
1 metric ton.....	1,000 kilograms.
1 gallon.....	231 cubic inches.
1 British imperial gallon.....	277.418 cubic inches.
1 gallon gasoline.....	6.50 ± pounds.
1 cubic foot of water weighs.....	62.287 pounds at 62° F.
1 gallon of water weighs.....	8.3267 pounds at 62° F.
1 knot.....	1.15 miles per hour.

To convert Fahrenheit to centigrade, subtract 32 and multiply by $\frac{5}{9}$.
To convert centigrade to Fahrenheit, multiply by $\frac{9}{5}$ and add 32.

U.S. OF
COURTESY

MACHINE GUNS.

NO. 1000 AEROPLANE

SECTION B.

MACHINE GUNS.

In dealing with the subject of the care of machine guns for aircraft mounting, it is assumed that the officers and men for whose use this handbook is intended are thoroughly familiar with the operation of these guns. Each man should have in his possession the handbooks issued by the Ordnance Department, which take up the subject of each gun in detail. These handbooks are given in the "List of reference books" and may be obtained from the Ordnance Department upon request. It will, therefore, be necessary to consider here only that phase of the subject of the care of the guns which applies particularly to aircraft. This will consist of a description of the special devices and attachments, with instructions concerning their use and care, and a list of precautions to be observed in connection with the care and adjustment of the guns.

Machine guns for aircraft are divided into two classes, according to the type of mount for which they are adapted.

The guns intended for installation on a fixed mount are Marlin, Browning, and Vickers.

The guns intended for installation on a flexible mount are Lewis.

The gun installed on a fixed mount is rigidly attached to the aircraft and synchronized with the engine, so as to make it possible to shoot between the blades of the propeller. The gun installed on a flexible mount does not shoot between the blades of the propeller and may be aimed independently of the machine. The mounts and synchronizing devices will be dealt with in a later section.

GENERAL PRECAUTIONS TO BE OBSERVED PREPARATORY TO FLIGHT.

CARE OF THE GUN.

The great importance of the proper care of machine guns designated for aircraft work should be fully realized, particularly inasmuch as the guns are working under adverse conditions, and a stoppage due to improper care or adjustment may prove fatal to the operator or at least result in the failure of his mission.

Inasmuch as some little time is always needed to get a machine ready for flight, it will not be necessary to keep the flexible guns mounted on machines, but they should be kept in their boxes until needed for use. It is very important

that these boxes be kept covered at all times to prevent the accumulation of dust and dirt on the guns. If it is necessary to keep any guns mounted in readiness for a flight, they should be protected by some sort of covering.

It is absolutely necessary to have the gun free from all traces of grit when it is ready for use. All parts should be thoroughly cleaned and the moving parts covered with a thin film of oil. The oil to be used is a light oil, known as airplane machine-gun oil, and is furnished by the Air Service.

It should be remembered that too much oil may give as much trouble as too little, due to its tendency to gum and clog the mechanism. The oil should be applied to the moving parts with the fingers or with a cloth patch or camel's-hair brush, and used sparingly.

The mechanism should work freely when operated by hand and the proper adjustments should be made. The cause of any excessive friction should be found and remedied. Burrs should be removed from hardened surfaces by means of a stone—never use a file for this.

A short burst should be fired before going up, in order to test the working of the gun.

Never send a gun up in an airplane when there is the slightest doubt of its functioning properly.

AMMUNITION.

It is essential that only the ammunition expressly designed for aircraft be used. This ammunition will be packed without clips and bandoleers, but in paper boxes of 20 cartridges per box. The wooden cases in addition to the other standard marking, will bear the following words: "For aircraft use—No clips or bandoleers."

In addition, the training insignia carried by airplanes, consisting of star within circle, will be stamped on each end of the packing box.

Each individual round should be carefully inspected. In the absence of cartridge gauges, the best service test applicable to discover defects in shape, is to drop each round into a spare barrel to see that it seats properly. A cartridge with a deep-set or deformed primer should never be tolerated.

Great care should be exercised in loading belts and magazines to see that the cartridges are all in correct alignment. Web belts should be *thoroughly dry* and should never be used when any round is held loosely enough to allow the least chance of its slipping out of position during flight. The cartridges should *never* be lubricated, as the oil itself or the dirt which it will collect, will prevent the cartridges from seating properly in the chamber. The loaded belt, whether

web or link, should always be placed zigzag in the belt box, never in the form of a roll.

SPARE PARTS.

The care of spare parts is a very important matter. Great pains must be taken to keep new parts separate from defective ones.

Spares should be kept in their proper receptacles, wrapped in oiled paper. The lids of the boxes should always be kept closed in order to prevent the accumulation of dust.

A strict account of the spares on hand must be kept and requisitions for additional parts must be made up in time to allow for delay in shipment.

GENERAL PRECAUTIONS TO BE OBSERVED AFTER A FLIGHT.

The gun should be immediately taken apart and every part thoroughly cleaned. Never allow a gun to remain dirty any longer than is absolutely necessary, as the action of the powder residue on the bore may seriously hamper the accuracy. Whenever possible, all parts should be washed in gasoline, *thoroughly dried*, and coated with a thin film of oil. All parts should be given a complete inspection, and any which show the least signs of wear should be removed and replaced with new ones.

It will be necessary to inspect the bore every day for several days and remove whatever residue has "sweated" out from the metal.

In applying cosmoline to the bore, only a small amount should be used on a cloth patch. The rod should be pulled slowly through the barrel and revolved sufficiently to allow the patch to follow the grooves of the rifling. This will give a thin coating of cosmoline, and any residue which "sweats" out from the metal can be readily detected. If too much cosmoline is applied, chemical action may take place between the residue and the metal underneath the cosmoline and can not be observed. It has been found that a film of cosmoline so thin as to be hardly noticeable is sufficient to prevent rust even when the barrel was exposed to the weather for a considerable length of time, provided the bore was clean before the cosmoline was applied. Rusty, worn, and pitted barrels cause tracer bullets to become "dead," i. e., they will not ignite.

INSPECTION.

All guns, spares, belts, and magazines should be inspected by the officer in charge of guns at least once a week. The guns should be completely stripped and the parts laid out for inspection.

TOOLS FOR MAINTENANCE OF LEWIS AND MARLIN AIRCRAFT MACHINE GUNS
TO BE SUPPLIED WITH ARMORER'S CHESTS FOR AIR SERVICE TRAINING
SCHOOLS.

Arms chest (Vickers) Ordnance Department drawing 16, class 76, division 13.....	1
Ball pean hammers, 12-ounce.....	2
Soft babbitt hammers, 15-5-180, U180C.....	6
Standard hammer handles.....	6
Sets mild steel drifts— $\frac{1}{8}$, $\frac{1}{16}$, $\frac{1}{32}$, $\frac{1}{64}$ inch.....	6
Bulldoze drifts, copper, $\frac{3}{8}$ by 4, $\frac{3}{8}$ by 6.....	4
Drill, hand and breast, with chuck to hold drills 0 to $\frac{3}{8}$ -inch, Goodell Pratt, 54B.....	1
Set assorted drills $\frac{1}{16}$ to $\frac{3}{8}$ by $\frac{1}{8}$	2



FIG. 1.—ARMORER'S CHEST.

Screw drivers, 5-inch.....	12
Screw drivers, 9-inch, all steel, Channon, 1.....	2
Pliers, 6-inch, round nose.....	3
Pliers, 6-inch, side cutting, 15-5-254.....	3
Large bench vise 3 $\frac{1}{2}$ by 4 inch jaw, Prentiss.....	3
Set copper jaws for same.....	3
Small hand vise, Simmons Hardware Co., No. 540.....	2
Sets copper jaws for same.....	2
Oil cans, dome type, 15-5-46.....	6
Pair 6-inch inside spring calipers, No. 610, Goodell Pratt.....	1
6-inch outside spring calipers, No. 504GP.....	1
3-inch dividers, No. 513GP.....	1
6-inch flexible Starret scales graduated hundredths and sixty-fourths.....	2
Center punches, small, GP.....	2
Scrapers, 3 $\frac{1}{2}$ -inch blade, No. 382GP.....	4

Sets oilstones, unmounted, 3 square, 1 round, 1 half-round, 1 three-cornered.....	2
Sets small chisels, $\frac{3}{8}$ and $\frac{1}{2}$ inch (black oil finish).....	2
Round-nose cape chisels, Cincinnati Tool Co.....	2
Sets files, smooth, single-cut, 6-inch, Nicholson, round, half-round, flat, and square.....	2
Sets files, double-cut, 8-inch, Nicholson, second cut.....	4
Standard aluminum file handles, 4130D.....	12
10-inch pipe wrench, Trimo.....	1
Adjustable S wrenches, 6-inch, Wescott pattern.....	2
6-inch monkey wrench, steel handle, Trimo.....	2
Hack-saw frames, adjustable, Starret Co., No. 146.....	2
Hack-saw blades, 24 teeth, Atkins Co., No. 310.....	12
Hack-saw blades, 14 teeth, Atkins Co., No. 320.....	12
Sheets, each, emery cloth Nos. 00, 0, $\frac{1}{2}$	6
Sheets Crocus cloth.....	6
Reflectors (dentist's mirror).....	3
Chamber reflectors for bore sighting.....	2
Set head space gauges, maximum and minimum.....	1
Armorer's pouches.....	6
Small bristle brushes.....	12
Camel's-hair brushes, small, for oiling parts.....	24
Lewis magazine gauge.....	1
Lewis gas regulator cup reamers.....	4
Padlock, Sargent, aircraft (padlock and chain).....	1
Marlin gas cylinder reamers.....	4

TOOLS FOR MAINTENANCE OF LEWIS AND MARLIN AIRCRAFT MACHINE GUNS TO BE SUPPLIED WITH EACH ARMORER'S TRUCK FOR USE WITH THE AIR SERVICE SQUADRONS.

Ball pean hammers, 16-ounce.....	2
Ball pean hammers, 12-ounce.....	4
Soft habbitt hammers, 15-5-180, U180C.....	6
Standard hammer handles.....	6
Sets mild steel drifts, $\frac{1}{16}$, $\frac{1}{8}$, $\frac{3}{16}$, $\frac{1}{4}$ inch.....	6
Bulldoze drifts, copper, $\frac{3}{8}$ by 4, $\frac{1}{2}$ by 6.....	4
Drill, hand and breast, with chuck to hold drills 0 to $\frac{3}{8}$ inch, Goodell Pratt, 5 $\frac{1}{2}$ B.....	1
Set assorted drills, $\frac{1}{16}$ to $\frac{3}{8}$ by $\frac{1}{16}$	1
Screw drivers, 5-inch.....	12
Screw drivers, 9-inch, all steel, Channon, 1.....	2
Pliers, 6-inch, round nose.....	3
Pliers, 8-inch, side cutting, 15-5-234.....	3
Large punch vise, 3 $\frac{1}{2}$ by 4 inch, jaw, Prentiss.....	3
Set copper jaws for same.....	3
Small hand vise, Simmons Hardware Co., No. 540.....	2
Sets copper jaws for same.....	2
Oil cans, dome type, 15-5-46.....	6
Pair 6-inch inside spring calipers, No. 610, Goodell Pratt.....	1
6-inch outside spring calipers, No. 504GP.....	1
Pair 3-inch dividers, No. 513GP.....	1
6-inch flexible Starrett scales, graduated one hundredth and sixty-fourth.....	2
Center punches, small, GP.....	2
Scrapers, 3 $\frac{1}{2}$ -inch blade, No. 382GP.....	4
Sets oil stones, unmounted, 1 round, 3 square, 1 half-round, 1 three-cornered.....	2

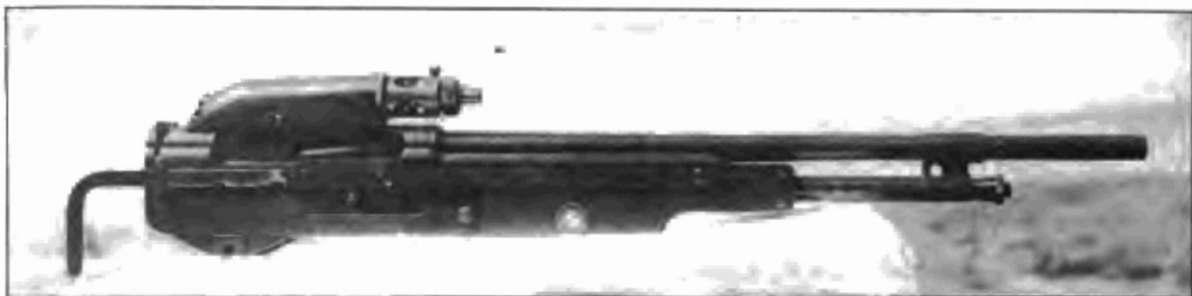
Sets small chisels, $\frac{3}{8}$ and $\frac{1}{4}$ inch (black oil finish).....	2
Round-nose cape chisels, Cincinnati Tool Co.....	2
Sets files, smooth, single cut, 6-inch Nicholson, round, half-round, flat, and square.....	2
Sets files, double cut, 8-inch, Nicholson, second cut.....	4
Dozen Standard aluminum file handles, 4130D.....	1
10-inch pipe wrench, Trimo.....	1
Adjustable S wrenches, 6-inch, Wescott pattern.....	2
6-inch monkey wrenches, steel handle, Trimo.....	2
Hack-saw frames, adjustable, Starrett Co., No. 146.....	2
Dozen hack-saw blades, 24 teeth, Atkins Co., No. 310.....	1
Dozen hack-saw blades, 14 teeth, Atkins Co., No. 320.....	1
Sheets, each, emery cloth, Nos. 00, 0, $\frac{1}{2}$	6
Sheets, crocus cloth.....	6
Reflectors (dentist's mirror).....	3
Chamber reflectors for bore sighting.....	2
Set head space gauges, maximum and minimum.....	1
Armorer's pouches.....	6
Small bristle brushes.....	12
Camel's-hair brushes.....	24

SPECIAL TOOLS FOR LEWIS GUNS.

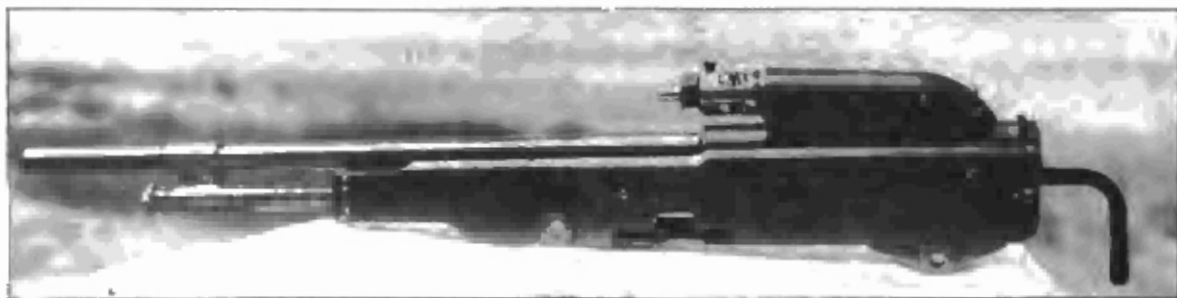
Left-hand die (barrel threads, muzzle end).....	1
Die holder.....	1
Gas regulator cup reamers.....	4
Magazine gauge.....	1

SPECIAL TOOLS FOR MARLIN GUNS.

Right-hand die (barrel threads breech rod).....	1
Taps (large side-plate screw).....	2
Taps (small side-plate screws).....	2
Tap wrench.....	1
Gas cylinder reamers.....	4



Right side.



Left side.

FIG. 2.—MARLIN AIRCRAFT MACHINE GUN. MODEL 1918.

MARLIN AIRCRAFT MACHINE GUN.

DESCRIPTION.

The Marlin aircraft machine gun is designed for fixed mounting and for use with a synchronizing device, either mechanical or hydraulic. It is fed from a disintegrating metallic link belt made up in 500-round lengths or more. The weight of the gun is 22 pounds, and the rate of fire, 680 shots per minute. The gun is described in detail in Ordnance Pamphlet No. 1933.

Marlin guns are packed for shipment in a wooden box 6 by 46 inches by 8½ inches deep, each box containing one gun and its spare parts.

POINTS TO BE OBSERVED BEFORE A FLIGHT.

The gun should have been thoroughly inspected for defective or worn parts, and all such parts replaced with new ones.

Test the operation of the "trip" by pulling the charging slide to the second notch and letting it slam down on the gauge.

Test the operation of the "no trip" by pulling the charging handle all the way to the rear and letting it slam down on the gauge.

All parts of the gun must be clean; special attention should be paid to the gas piston and gas cylinder, since these parts are directly subjected to the action of the gases and are therefore very liable to rust.

The following parts require particular attention in oiling:

Gas piston.

Slide.

Bolt.

Feed mechanism.

Carrier dog.

Lock container mechanism.

See that the gas adjuster thimble is screwed in tight.

Work the mechanism slowly back and forth several times by means of the charging slide to see that there is no excessive friction. If the mechanism does not work freely, the cause of the trouble must be found and remedied. Put several dummy cartridges through the gun to see that it is functioning properly.

Inspect the loaded belt for correct alignment of cartridges. See that gun is firmly fixed on its mount.

Make sure that the synchronizer will trip the trigger when the propeller is in the proper position.

Inspect the loaded belt for correct alignment of cartridges. See that gun is firmly fixed on its mount.

Make sure that the synchronizer will trip the trigger when the propeller is in the proper position.

MARLIN AIRCRAFT MACHINE GUN, FIRING MECHANISM.

Figure 2B shows the lock container of Model 1917 Marlin aircraft machine gun. This firing mechanism is not so satisfactory for synchronizing, in that if the trigger is released before the mechanism has reached the tripping position, the gun will fire when the sear is released by the trip, provided that the pressure of the trigger motor piston has not been removed from the trigger.

This slight delay in operation means that when the gun does fire it will be out of synchronism with the propeller.

Figure 3 shows the arrangement of parts in the lock container of the Model 1918 Marlin aircraft machine gun. Another trigger has been added which floats on the trigger and sear pin and fits in the same notch on the hammer with the sear. The rear end is backed up by a spring which tends to keep the hook on the front end pushed forward out of contact with the lug (*a*) on the synchronizer trigger.

The synchronizer trigger has been redesigned so that the piston acts on its cam surface within the lock container, and a small lug has been added to the right-hand side which may be engaged by the hook of the trigger.

The hammer has been lightened by cutting in the shape shown, and its stroke has been reduced to about three-eighths inch.

Operation.—In ordinary operation, when the sear is released the hammer drops onto the trigger, causing the trigger to move to the rear, compressing its spring and causing the hook to engage with the lug on the synchronizer trigger.

When the piston now strikes the cam on the synchronizer trigger, the synchronizer trigger is forced up and lifts the trigger out of engagement with the hammer. The hammer is then free to fall and strike the firing pin.

In case the synchronizer trigger has been struck by the synchronizer piston before the sear has been released by the trip, the synchronizer trigger alone is raised and does not lift the trigger with it, since the trigger is held forward by the trigger spring so that its hook is not engaged over the lug on the synchronizer trigger. Now the lug on the synchronizer trigger is directly behind the flat end of the hook on the trigger, and when the sear is tripped the hammer falls onto the trigger, forcing it to the rear so that the flat end of the

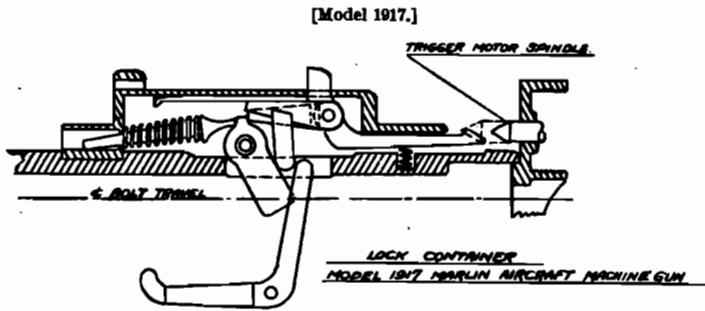


FIG. 2B.

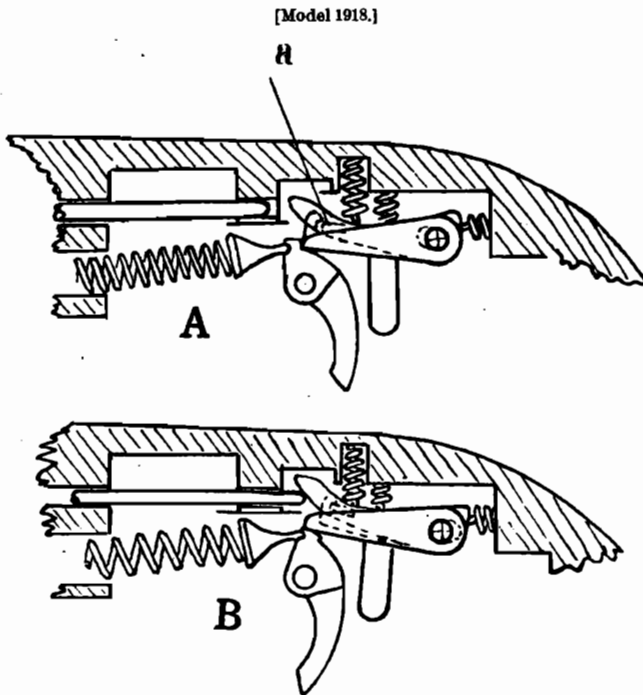


FIG. 3.

hook bears against the lug on the synchronizer trigger. The hammer is thereby prevented from falling.

As soon as the pressure of the piston is released from the synchronizer trigger, the synchronizer trigger is forced down by the synchronizer trigger spring, allowing the hammer to force the trigger to the rear so that it hooks over the lug on the synchronizer trigger. We now have the condition already explained in the preceding paragraph (sketch A) and the gun is fired at the next impulse of the synchronizer piston.

TRIGGER MOTOR.

The Model 1918 Marlin guns are supplied with a trigger motor attached to the lock container, adapted for connection to a C. C. synchronizing gear. The trigger motor consists of

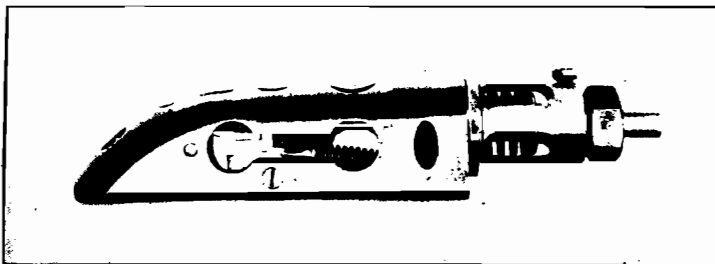


FIG. 4.—MODEL 1918 MARLIN LOCK CONTAINER AND TRIGGER MOTOR.

The lock container in above illustration is cut away to show internal mechanism.

a piston and spring contained in a bronze cylinder which is screwed into the forward end of the lock container. The cylinder is provided with a coupling nut and tube end into which the main pipe line may be soldered. A small vent screw located on top of the cylinder allows for the release of air from the system.

The C. C. synchronizing gear trigger motor as used with the Model 1917 Marlin aircraft gun is shown in figure (29), page 57.

ELECTRIC HEATER FOR MARLIN AIRCRAFT MACHINE GUN.

In order to prevent the oil gumming due to low temperatures when flying at high altitudes, electric heaters have been devised for the Marlin aircraft machine gun.

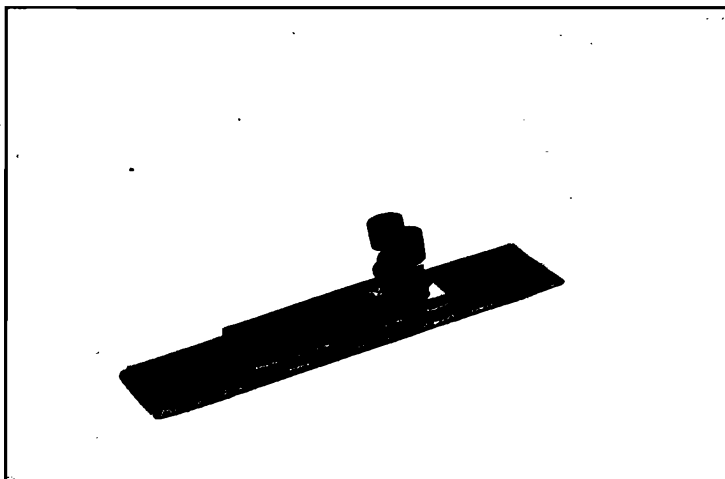


FIG. 5.—ELECTRIC HEATER FOR MARLIN AIRCRAFT MACHINE GUN.

This electric heater consists of a resistance grid surrounded by insulating material and is riveted to the inside of the bottom plate of the gun. It is connected with a bayonet plug on the underside of the bottom plate which provides for connection with the leads. The heater consumes 60 watts at 12 volts and is fed from the generator which supplies the lighting and heating system.

SPARES FOR MARLIN GUN.

The following spare parts are supplied with each Marlin aircraft machine gun and are packed with the gun in the packing case:

2 action springs.	4 ratchet lever pawl springs.
1 barrel.	2 ratchet lever pin washers.
1 bolt complete.	1 sear.
4 bolt pins.	2 sear springs.
4 buffer springs.	8 shell extractors.
2 carrier dog springs.	8 shell extractor pins.
1 carrier dog plunger spring guide.	8 shell extractor springs.
2 carrier stop springs.	1 trigger.
3 cartridge extractors.	4 trigger springs.
2 cartridge extractor cam springs.	1 trigger and sear pin.
3 cartridge extractor cams.	Needles.
3 cartridge extractor pins.	Needle screws.
1 cartridge guide, left-hand.	1 canvas protecting cover (for barrels).
1 cartridge guide, right-hand.	1 combination gas adjuster, wrench and screw driver.
2 cartridge retainer plunger springs.	1 combination barrel wrench, screw driver and action spring tool.
2 charging slide tension springs.	1 defective cartridge extractor.
2 ejector springs.	4 drifts (1 set).
2 feed throw-off springs.	1 oil can.
5 feed wheel dog pin cotter pins.	1 solid cleaning rod.
2 feed wheel dog springs.	1 trip gauge.
2 feed wheel dog pin washers.	1 rear mounting bracket (fitted to gun when shipped).
2 firing pins.	4 rear mounting bracket screws (fitted to gun when shipped).
4 firing pin springs.	1 paper container for spares.
2 firing pin stop pins.	1 belt loading machine and box for every four guns.
1 hammer.	
2 hammer springs.	
1 hammer spring guide.	
1 piston rod lock pin.	
1 piston rod lock pin spring.	
5 ratchet lever pin cotter pins.	

BASE SPARES.

With every oversea shipment of 1,000 or more aircraft machine guns, the necessary amount of base spares for the guns are also shipped. Base spares consist of parts of the guns in sufficient quantities calculated to best meet the demands of service.

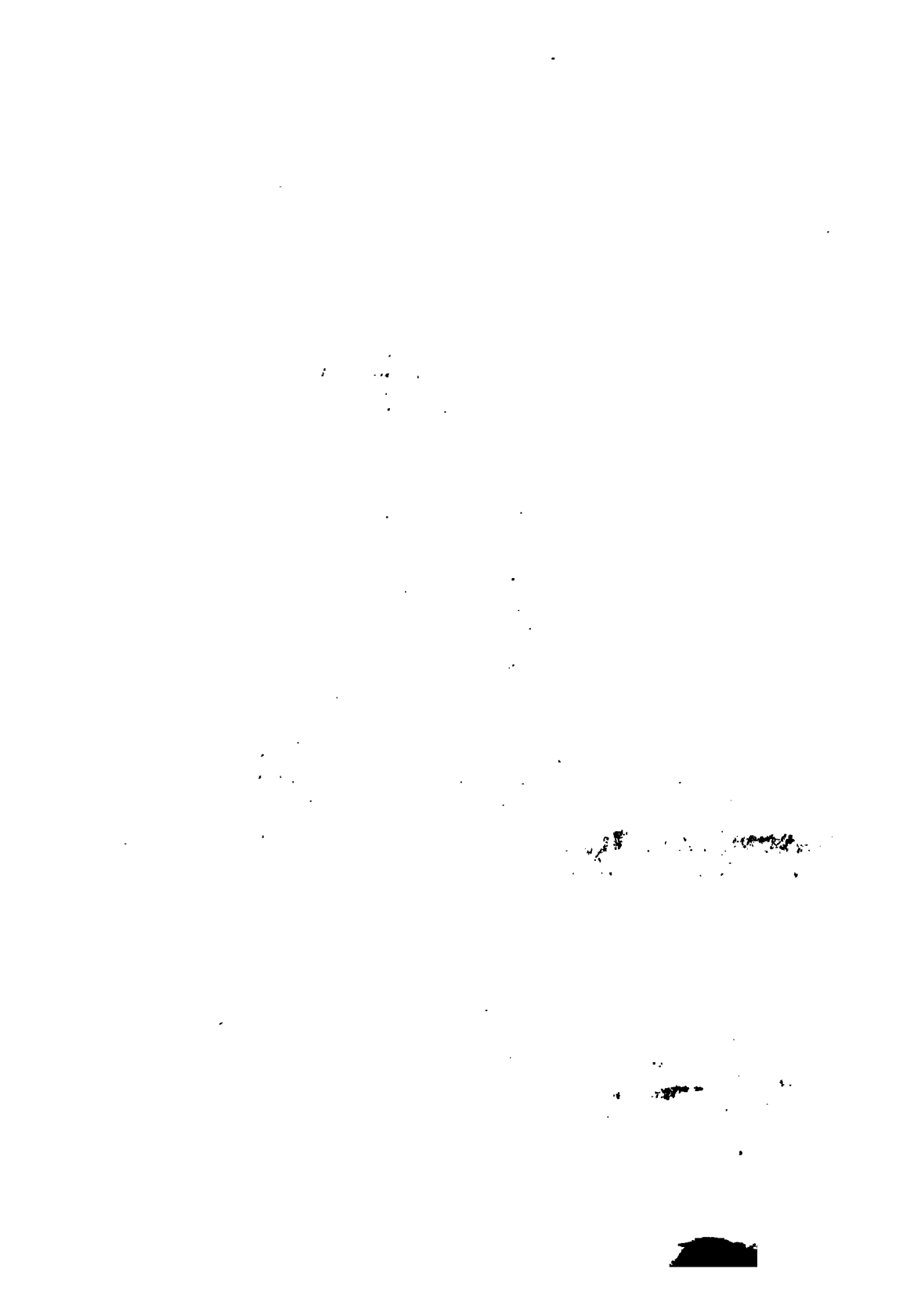
List of base spares, Marlin aircraft machine gun, model 1917 and 1918.

NOTE.—To find number of spare parts required, for a given number of guns, multiply the number of guns by the factors given and take the nearest whole numbers.

Article.	Factor.
Action spring guides (assembled), with belt guides.....	0.100
Belt guides.....	.100
Bolts, assembled.....	1.000
Consisting of:	
1 bolt.....	
1 firing pin.....	
1 firing-pin spring.....	
1 firing-pin stop pin.....	
1 shell extractor.....	
1 shell-extractor spring.....	
1 shell-extractor pin.....	
Bolt pins.....	2.000
Buffer blocks, assembled.....	.050
Consisting of:	
1 buffer block.....	
2 buffer-block springs.....	
Buffer-block pins.....	.100
Carrier, assembled.....	.250
Consisting of:	
1 carrier.....	
1 carrier dog.....	
1 carrier-dog pin.....	
1 carrier-dog spring.....	
1 carrier-dog plunger.....	
1 carrier-dog plunger spring guide.....	
Carrier-dog pins.....	.350
Carrier-dog plungers.....	.350
Carrier-dog plunger spring guide.....	.350
Carrier-dog springs.....	.350
Carrier pins.....	.250
Carrier stop springs.....	.100
Cartridge extractors.....	1.000
Cartridge extractor cam pins.....	.500
Cartridge extractor cam springs.....	1.000
Cartridge extractor springs.....	1.000
Chamber guides.....	.100
Charging slide guides.....	.100
Charging slide guide screws.....	.500
Charging slide retaining lugs.....	.100
Charging slide retaining lug screws.....	1.000
Ejectors.....	.275
Ejector springs.....	.275
Ejector spring plungers.....	1.000
Ejector stop screws.....	1.000
Feed lever, assembled.....	.250
Consisting of—	
1 feed lever.....	
1 feed lever pin.....	
Feed lever pins.....	.250
Feed lever screw.....	.300
Feed lever stop pin.....	.300
Feed throw-off.....	.250
Feed wheels.....	.070
Feed wheel dog spring stop pin.....	.100
Gas adjuster barrel.....	.100
Gas adjuster barrel pins.....	.100
Gas adjuster barrel pins.....	.100
Gas adjuster screws.....	.100
Gas adjuster thimble.....	.100
Gas adjuster thimble rivet.....	.100
Gas cylinder, assembled.....	.070
Consisting of—	
1 gas cylinder.....	
1 gas adjuster barrel pin.....	
1 gas adjuster barrel.....	
1 gas adjuster screw.....	
1 gas adjuster thimble.....	
1 gas adjuster rivet.....	

List of base spares, Marlin aircraft machine gun, model 1917 and 1918—Con.

Article.	Factor.
Gas piston, complete, rod and pins.....	.500
Receiver plug lock latch.....	.200
Receiver plug lock latch screw.....	.200
Observation slot cover, complete.....	.100
Ratchet lever, assembled.....	.100
Consisting of—	
1 ratchet lever.	
1 ratchet lever pawl.	
1 ratchet lever pawl spring.	
1 ratchet lever pawl pin.	
Ratchet lever pawl.....	.350
Ratchet lever pawl pins.....	.350
Receiver breech plug.....	.025
Side plate screws, rear.....	1.000
Side plate screws, front.....	2.000
Side plate screws, lock screw.....	2.400
Slides, assembled.....	.100
Consisting of:	
1 slide.	
1 cartridge extractor.	
1 cartridge extractor pin.	
1 cartridge extractor spring.	
2 cartridge guides.	
1 piston rod lock pin.	
1 piston rod lock pin spring.	
Side plate dowel rivet.....	.100
Hammer screws.....	1.000
Rear mounting bracket.....	.050
Rear mounting bracket screws.....	.200
Rear mounting bracket screw washers.....	.200
Trips.....	.500
NEW PARTS FOR NEW MODEL 1918 LOCK.	
Sears.....	2.000
Sear springs.....	2.000
Triggers.....	2.000
Trigger springs.....	2.000
Trigger spring guides.....	2.000
Trigger and sear screws.....	1.000
Trigger spring screws.....	2.000
Trigger spring screw lock washer.....	1.000
Synchronizer trigger.....	2.000
Synchronizer trigger spring.....	2.000
Hammer.....	1.000
Hammer springs.....	1.000
Hammerspring guides.....	1.000
Lock containers.....	.200
Bolt pin retaining plug.....	1.000





RING
R PIN



RING
R PIN

LEWIS AIRCRAFT MACHINE GUN.

DESCRIPTION.

The Lewis aircraft machine gun is designed for flexible mounting. As may be seen from the photograph, it differs



FIG. 6.—LEWIS AIRCRAFT MACHINE GUN.

from the Army type, in that the radiator has been removed, and a spade grip is used instead of a regular butt stock, and it is fitted with a special mounting yoke and recoil check. The gun is fed from a magazine holding 97 rounds.

The weight of the gun is 18 pounds, and the rate of fire 600 shots per minute. The ground type gun is described in Ordnance Pamphlet No. 1931.

These guns are usually installed in pairs or singly on a flexible mount.

Lewis guns are packed for shipment in a wooden box 40 inches by 4½ inches by 7½ inches deep, containing one gun and its spare parts. The magazines are packed in a wooden box 9½ by 11½ inches by 9½ inches deep containing three magazines. Six magazines in containers are supplied with each gun.

POINTS TO BE OBSERVED BEFORE A FLIGHT.

The gun must be in perfect operating condition, all parts cleaned and properly oiled.

The parts which need particular attention in oiling are:

Bolt.

Worm of feed operating stud.

Head of piston.

Striker post.

Slot in feed arm for feed operating stud.

Feed pawl (at pivot).

Stop pawls (at pivot).

Teeth on mainspring casing and on rack.

Threads on gas chamber gland and gas regulator cup.

Make sure that the hole in the gas chamber gland registers with the hole in the gas chamber, and the gas cylinder connection is tightly screwed onto the gas chamber.

See that the large gas port (No. 4) in the gas regulator cup is turned to the rear, thereby giving the maximum gas pressure on the recoiling parts.

The gun ordinarily operates with a spring tension of from 12 to 14 pounds. Due to the adverse conditions under which the gun works it may sometimes be necessary to reduce the tension to insure operation, but it should never be made less than 10 pounds.

Work the mechanism slowly back and forth several times by means of the charging handle to see that it runs smoothly.

The magazines for the Lewis gun should be very carefully inspected before being used, since a defective magazine is almost certain to give trouble. A little oil should be applied to the bearings and to the magazine latch. The latter should be tested to see that its spring works freely, as cases have been found where the latch did not return to its proper position to lock the magazine to the magazine post.

The magazines should be spun on a loading handle to see that they revolve easily. They should then be placed upon

the magazine post and rotated, in order to make sure that no part of the rim rubs on the receiver or feed cover.



FIG. 7.—97 ROUND LEWIS MAGAZINE WITH LOADING HANDLE.



FIG. 9.—97 ROUND LEWIS MAGAZINE—TOP VIEW.

The magazine gauge (see Fig. 10) should be used to test the rim of the pan and the position of the interior separator pins. The pins should be examined for straightness and firmness.

When not in use magazines should always ~~be kept~~ ^{be kept} in containers to prevent their becoming damaged or dirty. As a general rule, they should not be piled on top of each other, but if it is necessary to do this, they should all be turned with the hollow side downward and arranged evenly; this will obviate damage to the rims of the pans.

Make sure that the fixed sight, where supplied, is rigid.

See that the gun is firmly attached to its mount.

Make sure that the Bowden wire control, if used, will release the trigger.

RECOIL CHECK.

The recoil check is screwed to the muzzle of the gun, and consists of a disk with an opening for the bullet to pass

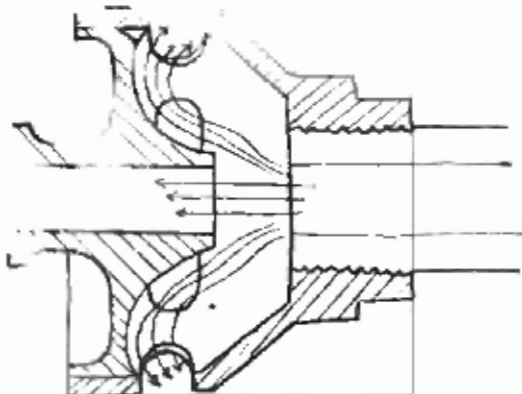


Fig. 9.—LEWIS RECOIL CHECK.

through. The rear surface of the disk is so shaped as to deflect the gases to the rear.

The operation of the recoil check is as follows:

A portion of the gases issuing from the muzzle of the gun strikes the rear surface of the disk and is deflected back (as shown by the arrows in the cross section view). This gives a forward impulse on the recoil check which tends to counterbalance the recoil of the barrel. In this way the recoil of the gun is limited to about 4 pounds.

TEST GAUGE FOR LEWIS MAGAZINE.

The gauge consists of a steel plate punched as shown in figures 10 and 11. A loading handle is put through the large hole and inserted in the magazine center as in loading. The gauge is then turned so that the interior separator pins appear two by two in the small openings. This checks the distance

from the center and the distance apart of the pins. The outside edge of the corrugations should appear opposite the small slit. The wider slit shows the tolerances which may be accepted; the inner or outer edge of the corrugation should be included within the inner or outer edge of the slit.

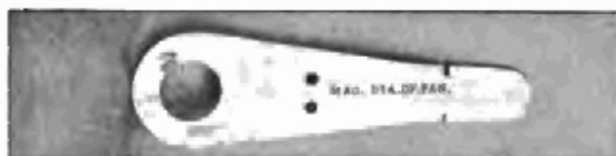


FIG. 10.—LEWIS MAGAZINE GAUGE.

SHELL DEFLECTOR BAG.

The empty shells from the Lewis gun are caught in a shell-deflector bag which is clamped to the receiver of the gun. This bag is made of heavy canvas reinforced with

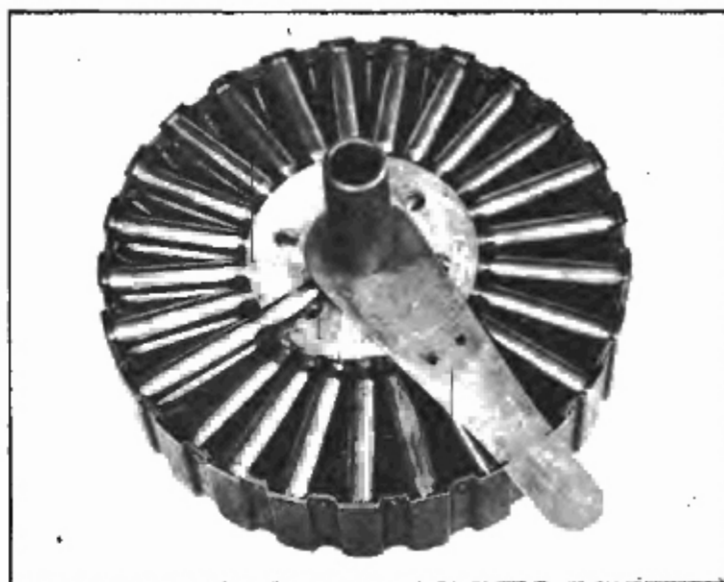


FIG. 11.—METHOD OF USING MAGAZINE GAUGE.

wire and held in a distended position by three wire loops. The bottom of the bag is closed by a flap which may be unclamped to permit the removal of the shells. The bag will hold 97 rounds, the contents of one magazine.

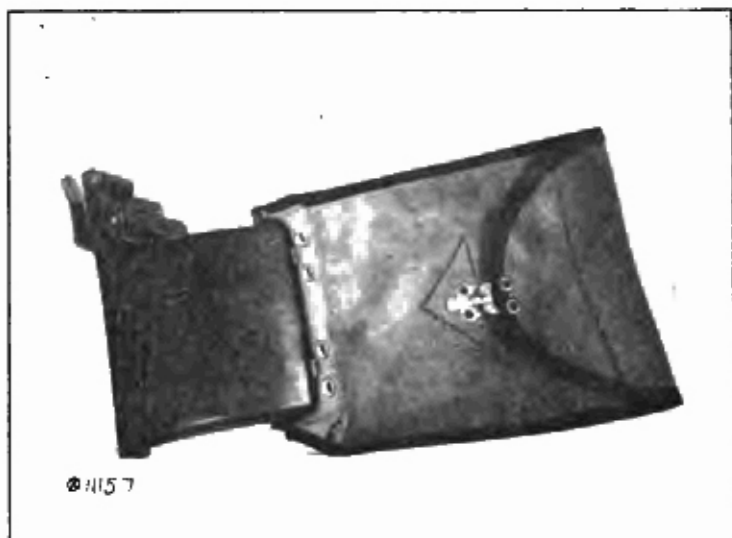


FIG. 12.—LEWIS SHELL DEFLECTOR BAG.

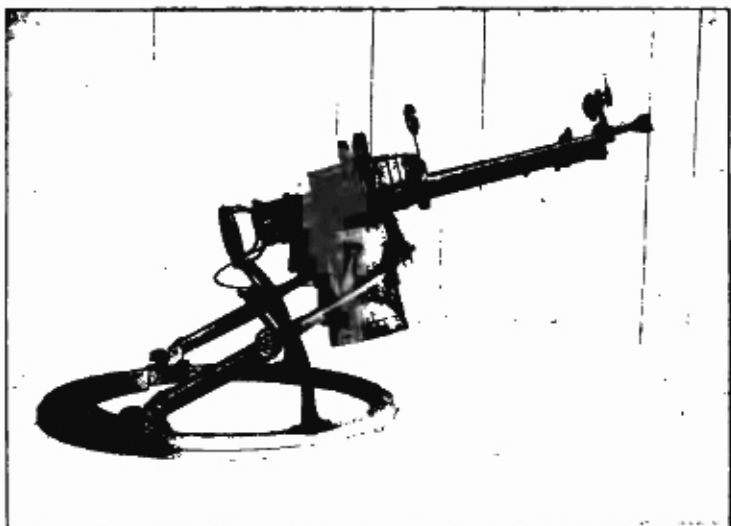


FIG. 13.—SHELL DEFLECTOR BAGS ON LEWIS GUN YOKE.

ELECTRIC HEATER FOR LEWIS GUN.

In order to prevent stoppages of the gun due to gummed oil caused by low temperatures when flying at high altitudes electric heaters are furnished for the Lewis aircraft machine gun, consisting of a resistance grid surrounded by insulating material. The heater is riveted to the underside of the feed cover and is connected with a plug on the top of the cover which provides for connections with the



FIG. 14.—ELECTRIC HEATER FOR LEWIS AIRCRAFT MACHINE GUN.

leads. The heater consumes 36 watts at 12 volts and is fed from the generator which supplies the lighting system.

SPARES FOR LEWIS AIRCRAFT MACHINE GUNS.

The following spares are furnished for each Lewis aircraft machine gun and are packed with the gun in the container:

Barrel.....	1
Bolt, assembled.....	1
Consisting of—	
Bolt.....	
Feed operating stud.....	
2 extractors.....	
Butt latch pin.....	1
Cartridge guides, assembled.....	2
Charging handle.....	1
Charging handle extension (wood).....	1
Combination cleaning rod (steel).....	1
Consisting of—	
Rod.....	
Adaptor.....	
Barrel cleaning brush (bristle).....	
Cylinder cleaning mop.....	
2 cylinder cleaning wire brushes.....	
Ejector.....	1
Extractors.....	2
Feed pawl springs.....	2
Gear stop pin.....	1
Gear stop spring.....	1
Gun box.....	1
Magazines (97 capacity) packed in magazine containers.....	6
Magazine containers (wood) for field use for 3 magazines each.....	2
Magazine loading handles in magazine containers.....	2

Mainspring	} assembled	1
Mainspring casing			
Mainspring collet			
Mounting yoke, assembled		1
Consisting of—			
Mounting yoke.			
Mounting yoke clamp.			
Mounting yoke axis pin.			
Mounting yoke axis pin washer.			
Mounting yoke axis pin cotter.			
Mounting yoke clamp key.			
Mounting yoke hinge pin.			
Oil can		1
Piston, assembled		1
Consisting of—			
Piston.			
Piston connecting pin.			
Rack.			
Striker.			
Striker fixing pin.			
Piston connecting pin		1
Receiver locking pin		1
Sear pin (or trigger pin)		1
Sear spring		1
Shell extractor		1
Sight retaining spring		1
Spanner		1
Spring balance		1
Stop and rebound pawl springs		2
Striker fixing pin		1
Hand books		4

Lewis aircraft machine gun, ratio table of base spare parts.

NOTE.—To find the number of spare parts required for a given number of guns, multiply the number of guns by the factors given, and take the nearest whole number.

Parts.	Factors.
Back sight axis pin	0.125
Back sight axis pin washer	.125
Back sight axis pin split keeper	.125
Back sight bed spring	.125
Back sight body	.125
Back sight stem	.125
Back sight stem nut	.125
Barrel	2.000
Barrel cleaning brush (bristle)	1.000
Barrel retaining nut	1.000
Bolt, complete, consisting of:	
Bolt.	
Feed operating stud.	
2 extractors.	
Butt plate	.125
Butt plate screw	.250
Butt tang screw	.250
Butt latch	.125
Butt latch pin	.250
Butt latch spring	.250
Cartridge guide, assembled	2.000
Charging handle	1.000

Lewis aircraft machine gun, ratio table of base spare parts—Continued.

Parts.	Factors.
Charging handle (extension).....	0.500
Combination cleaning rod (steel).....	.250
Consisting of:	
Handle.....	
Rod.....	
Combination cleaning rod adapter.....	.500
Cylinder cleaning brush (wire).....	2.000
Cylinder cleaning mop.....	1.500
Ejector.....	.500
Ejector cover.....	.250
Extractor.....	4.000
Feed cover, not assembled.....	.250
Feed operating arm.....	.020
Consisting of:	.125
Feed operating arm.....	
Feed pawl retaining pin.....	
Feed pawl.....	.250
Feed-pawl spring.....	1.000
Front-sight base.....	.125
Front-sight base screw.....	.500
Gas chamber.....	.250
Gas-chamber gland.....	.500
Gas-regulator cup.....	.500
Gas-regulator key.....	.250
Gas cylinder.....	.250
Gas-cylinder protector.....	.125
Gear.....	1.125
Gear casing.....	.063
Gear stop.....	.250
Gear-stop pin.....	.500
Gear-stop spring.....	.500
Guard assembly.....	.500
Consisting of—	.020
Guard.....	
Guard side piece, right.....	
Guard side piece, left.....	
2 guard side pieces (pairs only), including 2 rivets.....	
Locking jacks.....	.125
Magazine assembled (97 rounds).....	20.000
Magazine grip.....	1.500
Magazine grip-box rivet.....	5.000
Magazine latch assembly.....	1.500
Consisting of—	
Magazine latch.....	
Magazine latch-handle.....	
Magazine latch-handle rivet (2).....	
Magazine ribch spring.....	5.000
Magazine strap and clip.....	5.000
Magazine strap, rivet, and washer.....	10.000
Magazine center.....	500
Magazine spoor rivet.....	20.000
Magazine top plate.....	1.500
Magazine top plate rivet.....	20.000
Magazine coutisher cover catch.....	2.000
Magazine coutisher hinge.....	4.000
Magazine coutisher loading-handle clip.....	*.125
Magazine coutisher spring.....	1.000
Magazine leader, assembled.....	1.000
Magazine leader cartridge cut-off screw.....	.500
Magazine leader cartridge cut-off spring.....	.500
Magazine leader clip ejector screw.....	.500
Magazine leader clip ejector spring.....	.250
Magazine leader clip ejector plunger.....	.125
Magazine leader clip ejector screw.....	.250
Magazine leader post nut.....	.125
Magazine loading handle.....	.125
Mainspring.....	4.000
Mainspring casing.....	.125

Lewis aircraft machine gun, ratio table of base spare parts—Continued.

Parts.	Factors.
Magazine collet.....	0.250
Magazine collet pin.....	.250
Magazine retaining rivet.....	1.000
Mounting yoke, assembled.....	.250
Consisting of—	
Yoke.....	
Yoke clamp.....	
Yoke clamp key.....	
Yoke axis pin.....	
Yoke axis pin washer.....	
Yoke axis pin split keeper.....	
Yoke hinge pin.....	
Mounting yoke clamp key.....	.125
Mounting yoke axis pin.....	.125
Mounting yoke axis pin washer.....	.500
Mounting yoke split keeper.....	.500
Oil can.....	.250
Piston.....	.250
Piston connecting pin.....	.500
Rack.....	.125
Rear sight base.....	.125
Rear sight base rivet.....	1.000
Rebound pawl.....	1.000
Receiver locking pin.....	2.000
Recoil check.....	.250
Consisting of—	
Body.....	
Cap.....	
Safety.....	.125
Sear.....	.500
Sear pin (or trigger pin).....	4.000
Sear spring.....	4.000
Shell deflector, assembled.....	1.000
Shell deflector bag, with hooks and buckle.....	.125
Shell deflector bracket fixing screw.....	.250
Shell deflector bracket fixing screw washer.....	.250
Shell deflector bracket fixing screw stop nut.....	.250
Shell deflector latch.....	.250
Shell deflector latch screw.....	.250
Shell extractor.....	.500
Sight retaining spring.....	1.000
Spade grip, assembled.....	.100
Consisting of—	
Spade grip handle.....	
Spade grip tang.....	
Spade grip tang screw.....	
Spade grip handle.....	.125
Spade grip tang.....	.125
Spade grip tang screw.....	.250
Spanner.....	1.000
Spring balance.....	.250
Stop pawl.....	1.000
Stop and rebound pawl spring.....	4.000
Striker.....	2.000
Striker fixing pin.....	4.000
Trigger.....	.250

T
cool
plac
atta
nizi
sing
typ
in
plis
cap
frot
mo

7
in
diff
me

ele

b
tl
fi
l

VICKERS AIRCRAFT MACHINE GUN.

DESCRIPTION.

The Vickers aircraft machine gun differs from the water-cooled type in that the water-cooling system has been displaced by a skeletonized steel tube and a device has been attached to permit of the gun being used with a synchronizing gear. The guns are installed on fixed mounts either singly or in pairs. In many cases the American water-cooled type guns shipped abroad for ground work were remodeled in France to fit them for use in aircraft. This was accomplished by skeletonizing the water jacket and water jacket cap to permit the free circulation of air for cooling. The front and rear covers were then milled out to permit the mounting of different types of trigger motors.

FEED.

The gun is fed from a metallic link belt similar to that used in the Marlin aircraft machine gun, the links being of slightly different design to adapt them for use in the feed box. The method of loading the belt is described. (See p. 44.)

POINTS TO BE OBSERVED BEFORE A FLIGHT.

The gun should be in perfect operating condition, all parts clean and properly oiled.

The parts which require particular care in oiling are:

Rear bearing of barrel (in trunnion block).

Front bearing of barrel.

Side plate cams.

Guides for lock on recoil plates.

Guides for lock on rear cover.

Feed box slide.

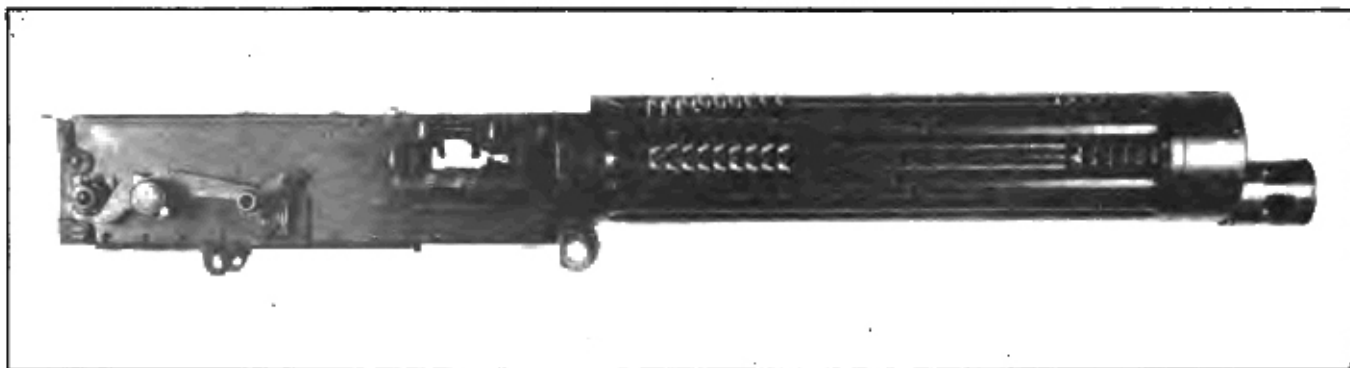
Carrier (where it slides on lock frame).

Crank pin.

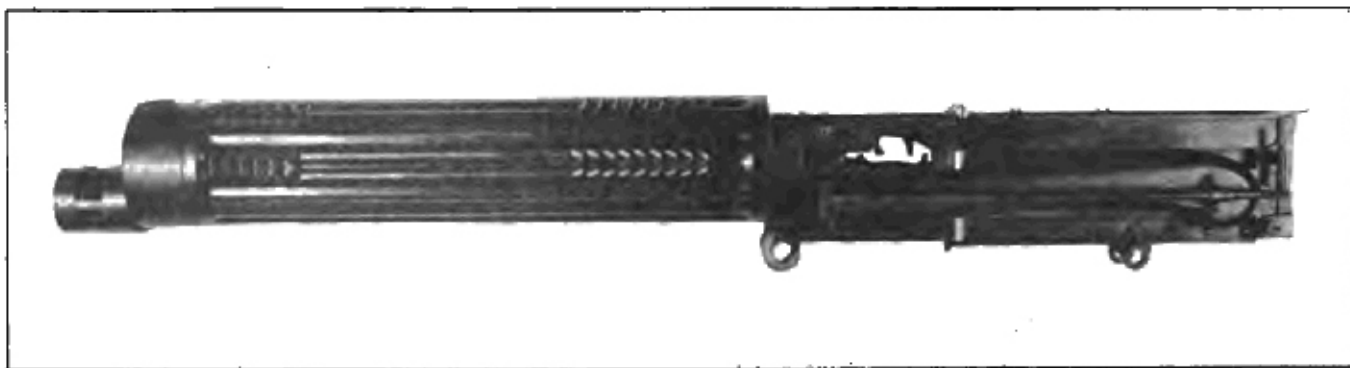
Test the engagement of the safety sear with the firing pin by pulling back slowly on the roller handle and listening for the click.

Adjust the tension on the recoil spring so that it weighs from 7 to 9 pounds.

Weigh the friction of the recoiling parts—this should be less than 4 pounds.



Right side.



Left side.

FIG. 15.—VICKERS AIRCRAFT MACHINE GUN, CAL. .30, MODEL 1918.

Make sure that the barrel disk, front disk, and follower where used are screwed up tight.

Always keep the adjusting nut tight.

Work the mechanism slowly several times to see that it operates smoothly and remove any cause of friction.

Inspect the loaded belt for correct alignment of cartridges.

See that the gun is firmly fixed on its mount.

Make sure that the synchronizing device will release the hand sear.

Wipe all oil off face of lock.

ELECTRIC HEATER FOR VICKERS GUN.

In order to prevent the oil from gumming due to the low temperature at high altitudes, the lock of the Vickers gun is kept warm by two small electric heating elements attached

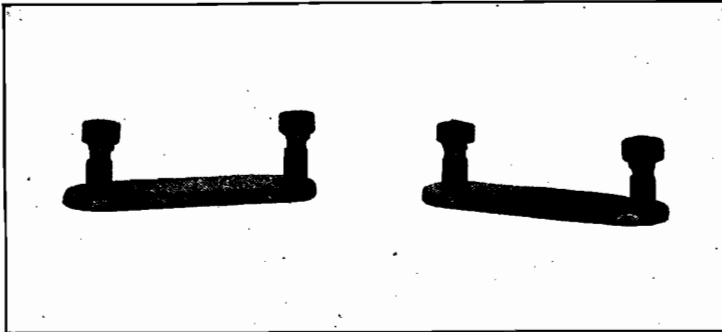


FIG. 16.—ELECTRIC HEATER FOR VICKERS AIRCRAFT MACHINE GUN.

to the inside of the side plates. The heaters consist of a grid of resistance wire contained between two copper plates and insulated from them by mica.

The heaters are superimposed on the side cams and attached by binding posts through the side plates, providing terminals for lead connections. Each heater consumes 18 watts, at 12 volts, and is fed from the generator which supplies the lighting system.

U. S. 30 CAL. VICKERS LOADING HANDLE.

Description.—The U. S. loading handle for the 30 Calibre Vickers gun consists of a handle arm and an operating cam which are joined together by means of three bolts. Several bolt holes in the operating cam permit the adjustment of the handle arm to suit the type of machine on which the gun is mounted. The loading handle is attached to the gun by means of a bolt which replaces the handle block pin.

Operation.—In loading the gun the belt is inserted in the feed box and the handle arm is depressed twice. When the handle arm is depressed the operating cam rotates the roller handle and also recoils the barrel, thereby operating the feed mechanism. This is very convenient in the case of a misfire in that it obviates the necessity of pulling in the belt while the roller handle is being rotated.

STANDARD SPARE PARTS AND ACCESSORIES SHIPPED WITH EACH VICKERS AIRCRAFT MACHINE GUN, MODEL OF 1918.

Each of the above guns to be accompanied with the following parts, tools and accessories:

Article.	Number of parts.
Muzzle attachment, complete, consisting of.....	1
Barrel disc.....	1
Sleeve with pin, riveted.....	1
Follower.....	1
Front disc.....	1
Front disc cap.....	1
Locking pin.....	1
Chain.....	1
Eyebolt.....	1
S hook.....	1
Securing chain ring.....	1
Cleaning rod.....	1
Adjusting washers (thin).....	3
Adjusting washers (thick).....	3
Barrel.....	1
Feed box, complete.....	1
Firing pin.....	1
Fusee, with links, complete.....	1
Gib.....	1
Recoil spring, complete.....	1
Spring, bullet guide with screw.....	1
Spring, bottom pawl.....	1
Spring, dead stop plunger.....	1
Springs, gib.....	2
Springs, main.....	4
Spring, rear cover catch.....	1
Spring, safety sear.....	1
Spring, upper pawl.....	1
Front disc cap.....	1
Handle block pin.....	1
Tumbler.....	1
Tumbler pins.....	2
Hand sear pins.....	2
Split pins (for handle block hinge pin, nut, etc.).....	3
Aerial loading handle hinge pin and bolt nut.....	1
Aerial loading handle sleeve.....	1
Aerial loading handle washer.....	1
Aerial loading handle fastening screws.....	3
Aerial loading handle fastening screw nuts.....	3
Aerial loading handle fastening screw lock washers.....	6
Accentuator spring.....	1
Front cover catch pin.....	1
Fusee tension screw, assembled, complete.....	1
Fusee tension screw gear, assembled, complete.....	1
Combined spanner.....	1
Drift, steel, round.....	1
Drift, steel, octagonal.....	1
Spring balance.....	1
Lock, complete.....	1

BASE SPARE PARTS FOR VICKERS AIRCRAFT MACHINE GUN,
MODEL 1918.

To find number of spare parts required for a given number of guns, multiply the number of guns by the factors given and take the nearest whole numbers.

Number per gun.	Article.	Factor.
1	Barrel.....	4.750
1	Barrel disk.....	.323
1	Bottom pawl, left hand.....	.323
1	Bottom pawl, right hand.....	.323
1	Bottom pawl connecting plate.....	.290
1	Bottom plate. (See Casing.)	
1	Carrier, complete.....	.133
1	Cartridge guide and stop.....	.900
1	Cover guide, right hand. (See Casing.)	
1	Cover guide, left hand. (See Casing.)	
1	Crank.....	.900
1	Crank pin fastening pin.....	.517
1	Crosshead.....	.290
1	Dead stop.....	.290
1	Dead stop bracket. (See Casing.)	
1	Dead stop plunger.....	.517
1	Dead stop plunger stop.....	.517
1	Distance piece for lock frame.....	.047
3	Eyebolts.....	.290
1	Feed box, complete.....	.147
1	Feed box upper lever.....	.947
1	Feed box bottom lever.....	.047
1	Feed box slide.....	.047
1	Filling piece (lock frame).....	.125
1	Firing pin.....	1.365
1	Follower.....	.500
1	Front cover with catch bracket.....	.047
1	Front cover catch.....	.350
1	Front cover stop. (See Casing.)	
1	Casing, consisting of parts riveted and assembled as follows.....	.023
	Bottom plate.....	
	Dead stop bracket.....	
	Front cover stop.....	
	Outside plate, left, with riveted cam.....	
	Outside plate, right, with riveted cam.....	
	Rivets.....	
	Spring box front studs.....	
	Stuffing box.....	
	Trunnion block.....	
	Trunnion block distance piece.....	
	Water-jacket cap.....	
	Water-jacket trough.....	
	Water jacket.....	
	Rivets, securing trough.....	
1	Rear cover, assembled, consisting of.....	.047
	Rear cover.....	
	Rear-cover guide, right hand.....	
	Rear-cover guide, left hand.....	
	Rear-cover guide stud for spring.....	
1	Front disk.....	.043
1	Front disk cap.....	2.480
1	Fusee link, front.....	
1	Fusee link, rear.....	
1	Fusee link rivet.....	.373
1	Fusee link end pin.....	
1	Fusee.....	.323
1	Gib.....	.290
1	Gib-spring plate.....	.290
1	Handle block.....	.013
1	Handle-block pin.....	.290
1	Hand sear.....	.290
1	Lock, complete.....	.100

Number per gun.	Article.	Factor.
1	Lifting lever, left hand	\$0.280
1	Lifting lever, right hand	.290
1	Lock frame with filling piece, distance piece, and safety sear pin, assembled	.133
1	Muzzle attachment securing chain	.517
1	Nut, adjusting	.517
1	Nut, cover hinge pin	.517
1	Outside plate filling piece w/stud	.113
1	Outside plate, left, w/riveted cam	} see casing.
1	Outside plate, right, w/riveted cam	
1	Pin, bottom pawl	.280
1	Pin, cover hinge	.290
1	Pin, crank	.290
1	Pin, dead stop	.517
1	Pin, end link	.517
1	Pin, feed-box lever	.517
1	Pin, filling piece (lock frame)	.123
1	Pin, hand sear	.290
1	Pin, locking (muzzle attachment)	.290
1	Pin, muzzle-attachment stop	.350
1	Pin, rear cover catch hinge	.290
1	Pin, safety sear	.290
1	Pin, side lever	.290
1	Pin, tumbler	.290
1	Pin, upper pawl	.123
1	Recoil plate (left hand)	.133
1	Recoil plate (right hand)	} Each with carrier supporting spring riveted.
1	Rear cover catch	
1	Recoil spring hook	.100
1	Recoil spring nut	.200
2	Rivets, bottom and outside plate, short	.025
4	Rivets, bottom pawl	.740
4	Rivets, carrier supporting spring	.872
4	Rivets, cartridge guide and stop	.117
1	Rivets, chain link	.140
2	Rivets, dead stop bracket and outside plate (for casing)	.117
1	Rivets, fusee	1.000
1	Rivets, lock frame for distance piece	.050
3	Rivets, long	.073
42	Rivets, casing and covers	.117
1	Rivet, dead stop bracket	.073
3	Outside plate and cams, left	.117
2	Rivets, outside plate and dead stop bracket, short	.106
7	Rivets, outside plate and cams	.106
2	Rivets, trunnion block and outside plate	1.413
1	Roller	.290
1	Roller bracket	.113
1	Roller handle, complete with knob	.113
1	Roller handle knob	.008
1	Safety sear	.290
1	Screw securing crank handle	.290
1	Screw, recoil spring tension w/handle	.290
1	Screw, steel, .190 by .115 countersunk head (bullet guide)	.290
1	Side lever	.113
1	Side lever pin bushing	.298
1	Slotted, muzzle attachment w/stop pin riveted	.043
1	Spring, bottom pawl	1.522
1	Spring box	} assembled
1	Spring box fixing, front	
1	Spring box fixing, rear	
1	Spring box front stud	.532
1	Spring box rear stud	.372
1	Spring bullet guide	.315
1	Spring carrier supporting, left hand	.709
1	Spring carrier supporting, right hand	.708
1	Steel pin roller washer, .125 by 1	1.547
1	Spring, dead stop plunger	.350
1	Spring, etc.	1.148
1	Spring, main	1.204
1	Spring, rear cover catch	.350
1	Spring, recoil w/hook and nut	.323
1	Spring, safety sear	1.148

Number per gun.	Article.	Factor.
1	Spring, upper pawl.....	\$0.073
1	Stuffing box. (See Casing.)	
1	Stud, rear cover catch spring.....	.240
1	Tension screw handle with washer, assembled.....	.047
1	Trunnion block. (See Casing.)	
1	Trunnion block, distance piece. (See Casing.)	
1	Tumbler.....	.290
1	Upper pawl, left hand.....	.323
1	Upper pawl, right hand.....	.323
3	Washer, adjusting (thick).....	1.980
3	Washer, adjusting (thin).....	1.980
1	Washer, roller.....	.340
2	Washer, tension screw handle.....	.323
1	Water jacket.....	
1	Water-jacket cap.....	
1	Water-jacket trough (complete, ready to assemble to rear part of casing).....	.012
1	Stuffing box.....	
4	Rivets, securing trough.....	
1	Water jacket with trough, riveted.....	.013
1	Split pin for front cover catch.....	1.654
1	Adjusting handle shaft bracket, front.....	.050
1	Adjusting handle shaft bracket, rear.....	.050
1	Adjusting handle shaft collar.....	.100
1	Adjusting handle shaft collar pin.....	.100
1	Adjusting handle shaft gear.....	.050
1	Adjusting handle shaft guard.....	.100
1	Accentuator spring.....	.500
1	Bracket for front cover catch.....	.050
1	Front cover catch pin.....	.200
1	Fusee link tension screw.....	
1	Fusee spring tension screw gear.....	.200
2	Pins for fusee spring tension screw.....	.200
1	Tension screw adjusting handle shaft.....	.050
AERIAL LOADING HANDLE LIST.		
1	Operating arm.....	.250
1	Handle arm.....	.250
1	Operating handle knob.....	.050
1	Hub.....	.050
1	Hinge pin and bolt nut.....	.500
1	Sleeve.....	.100
1	Hinge pin and bolt.....	.200
2	Washer.....	.500
3	Fastening screws.....	1.000
3	Fastening screw nuts.....	1.000
6	Fastening screw nuts lock washers.....	2.000

All base spare parts for Vickers tripod Mark IV, Model 1915, eliminated.

"SPEEDED-UP" VICKERS AIRCRAFT MACHINE GUN, CAL. .30.

In order to provide an increased rate of fire of the Vickers aircraft machine gun to meet the requirements of active service conditions certain attachments are provided which bring up the rate of fire to between 950 and 1,000 shots per minute. These consist of a special muzzle attachment and a redesigned back plate, embodying a buffer which causes a quicker return of the action of the gun.

The Vickers gun in figure 17 is fitted with the "speeding-up" attachments.

11 m/m VICKERS AIRCRAFT MACHINE GUN.

The 11 m/m Vickers aircraft machine gun differs from the .30 caliber gun only in the size of some of its parts. It is designed for the use of incendiary and tracer ammunition in attacking observation balloons. The muzzle velocity of the 11 m/m ammunition is somewhat lower than that of the service ammunition, but it is sufficient to enable attack on observation balloons at relatively long ranges, beyond the barrage set up in their defense.

This gun operates in exactly the same manner as the .30-caliber gun, and the same precautions regarding care apply to both.

DISINTEGRATING METALLIC LINK BELT.**DESCRIPTION.**

The metallic link belt is made up of individual links held together by the cartridges which it contains. The metallic belt is fed into the machine gun in the same manner as a web belt, but as the cartridges are extracted the links are no longer held together and drop out of the gun one at a time.

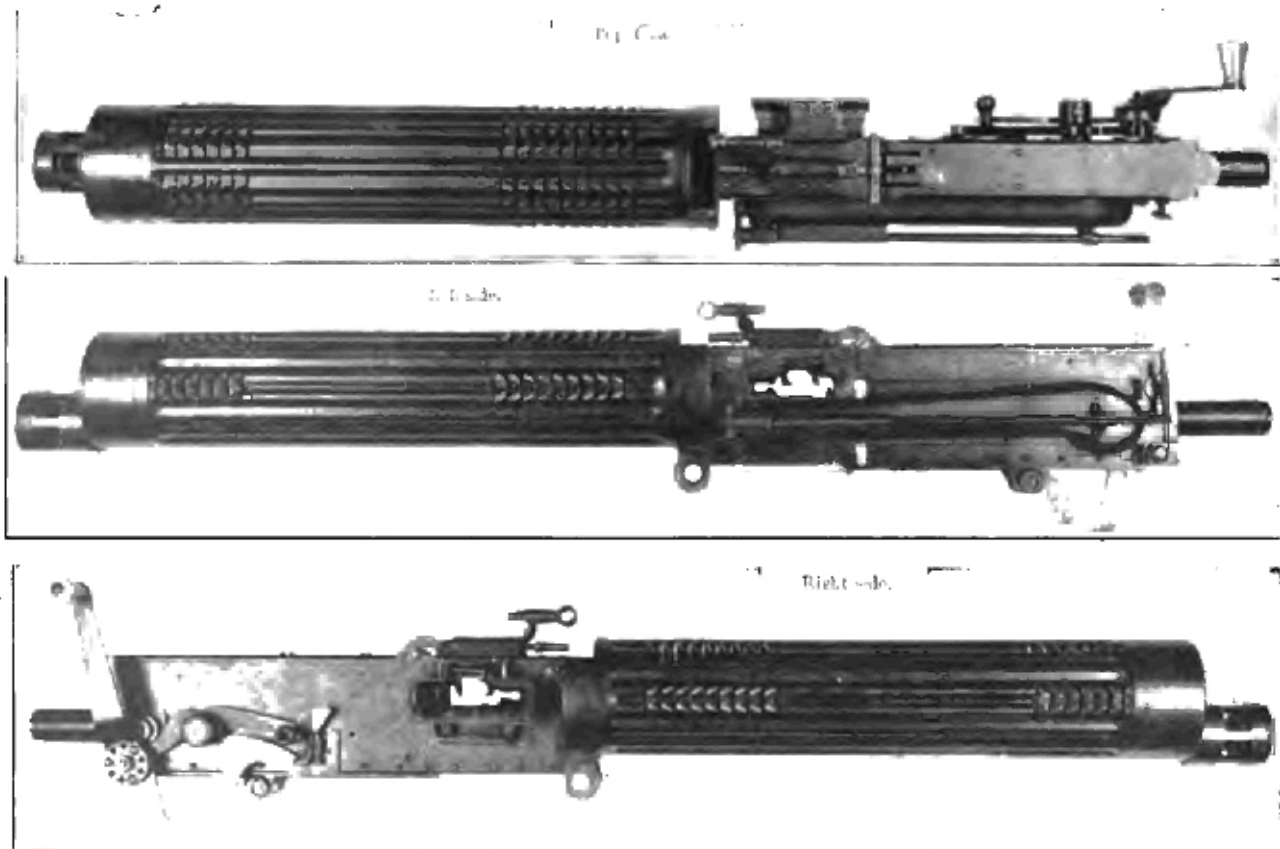


FIG. 17.—UNITED STATES VICKERS AIRCRAFT MACHINE GUN, CAL. .30, WITH LOADING HANDLE, SPEEDING-UP ATTACHMENTS, AND TRIGGER MOTOR FOR MECHANICAL SYNCHRONIZING GEAR, TYPE H-S.

LOADING.

The method of loading is as follows: Twenty links are placed in the corrugations of the base of the loading machine so joined together as to form a section of the belt. Twenty cartridges are then placed in the corrugations behind the links and the pushing bar is pushed forward by means of the handle. This forces the cartridges the proper distance into the links, thereby joining a section of the belt. This section is then moved to the left or right so that the last cartridges rest in the support provided, allowing the unoccupied loop of the last link to line up with the first link of the next section. (See figures 19, 20, 21.)

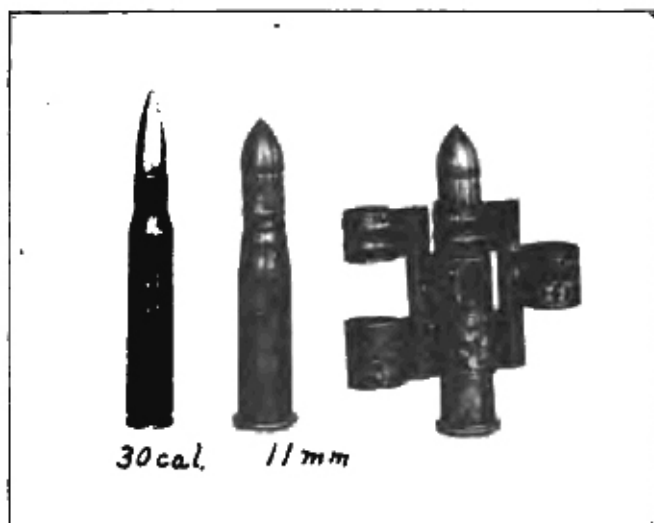


FIG. 18.—11-MM. AMMUNITION AND BELT LINKS COMPARED WITH 30-CAL. AMMUNITION.

PACKING.

Metallic links are packed in cardboard containers (see figs. 20-21) holding 10 links in each. These containers are designed to facilitate laying out the links on the loading machine.

Twenty-five containers, one of which, marked with a red stripe, contains a link fastened to a brass strip 6 inches long, are packed in a carton. This strip is for threading the belt through the gun.

Forty cartons, containing 10,000 links, are packed in a wooden box ready for shipment and marked "For aircraft use."

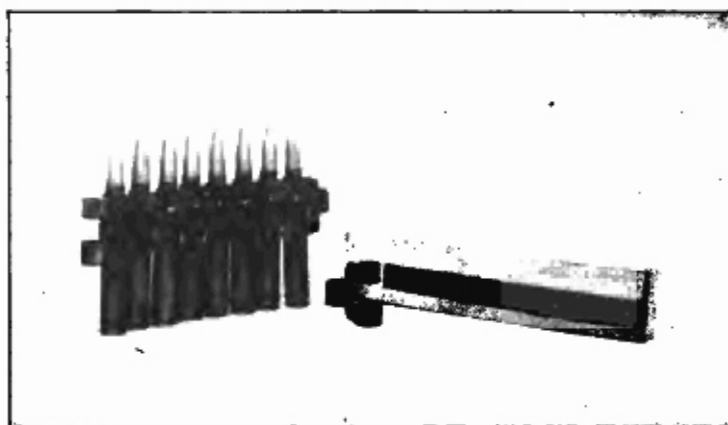


FIG. 19.—MARLIN-BROWNING BELT LINKS SHOWING CARDBOARD CONTAINER.

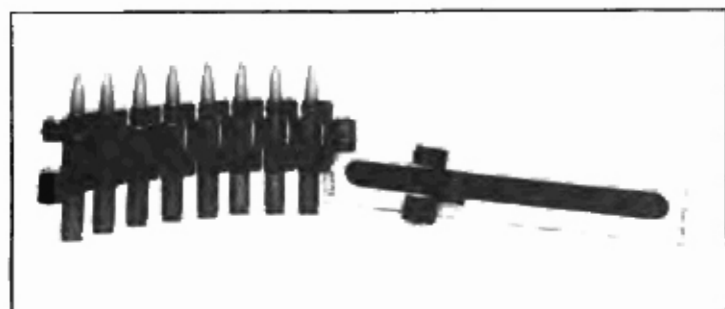


FIG. 20.—VICKERS BELT LINKS SHOWING CARDBOARD CONTAINER.

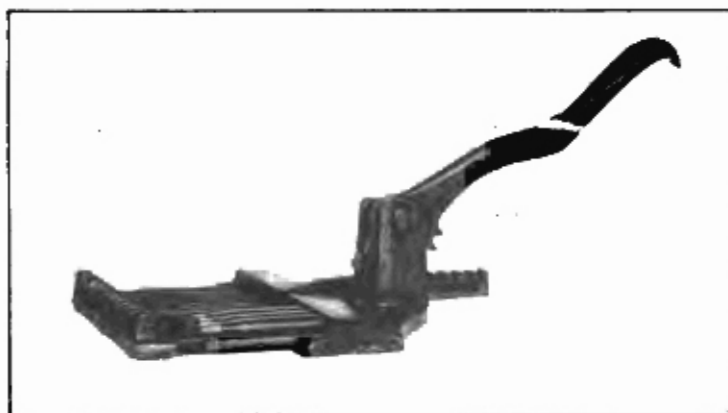


FIG. 21.—LOADING MACHINE FOR DISINTEGRATING BELTS. MODEL 1918.

SECTION C.

AIRCRAFT MACHINE GUN MOUNTS.

The mounts for aircraft machine guns are divided into two classes—fixed and flexible.

Fixed mounts are attached to the airplane in front of the pilot's cockpit, either on top or underneath the cowling, holding the guns rigid so that they may be synchronized with the engine to shoot between the blades of the propeller.

Fixed mounts vary according to the types of guns and planes for which they are intended, usually consisting of two brackets, one of which allows for lateral and vertical adjustment so that the guns may be lined up with the sights. Fixed guns are mounted singly and in pairs.

Flexible mounts are attached to the airplane above the gunner's cockpit, and permit of moving the guns through a considerable arc of fire independently of the airplane.

FIXED MOUNTS.

Figure 22 shows two Marlin aircraft machine guns mounted on the cowl of a DH-4 plane and fitted with C. C. synchronizing gears.

The front mounting bracket is a bronze casting and consists of a base plate curved to fit the cowl with two upright side plates, one of which is threaded to receive the forward gun bolt. The brackets are attached to the cowl by means of four small bolts, and are set 14 inches from center to center.

The rear mount consists of a bronze socket attached to the cowl by means of six bolts. This socket receives a brass post, which may be adjusted for height by a knurled nut located underneath the cowl and clamped by means of an hexagonal nut on the lower end of the post. The top of the post is made in the form of a T head, threaded to receive the rear gun bolt. This allows for lateral adjustment, and the gun may be clamped by means of the small bolt provided.

To adjust the guns, the plane is placed so that the Unit, and the Ring and Post sights may be sighted on a target at a set distance. After the necessary adjustments have been made to the sight brackets, they are clamped in place. The guns are then mounted and a sight is taken through the bores at the same target, the adjustments being made on the rear bracket. This means that the center lines of the gun converge to meet at a predetermined distance. The guns are now correctly mounted and must be firmly clamped.

BELT BOXES AND SHELL CHUTES.

The aluminum belt boxes are located inside the cowl and bolted to it, one underneath each gun. The covers of the boxes are shaped to act as a guide for the loaded belt being fed into the gun, and are provided with catches to keep these closed. Between the two belt boxes is installed the aluminum shell and link chute for the left-hand gun, and ejects through the bottom of the fuselage. This is also bolted to the cowl and is provided with a cover which fits over the ejection and belt openings of the gun. The shells and links for the right-hand gun are carried down outside the fuselage by separate chutes attached to the cowl.

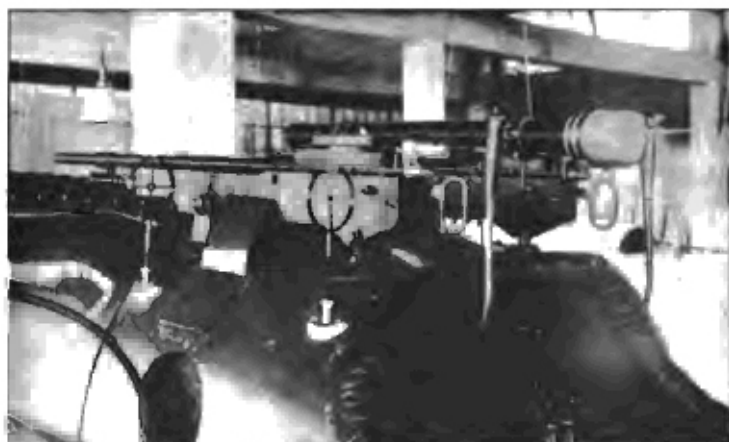


FIG. 22.—FIXED MOUNTS FOR TWO MARLIN AIRCRAFT MACHINE GUNS ON DE HAVILLAND 4.

Care must be taken to see that the belt box covers do not become bent so as to hinder the feeding of the belt. The catches must be kept in proper order so that there is no possibility of the covers becoming unlatched by the weight of the loaded belt when the machine is upside down.

FLEXIBLE MOUNTS.

AIRPLANE FLEXIBLE GUN MOUNT, TYPE A.

The airplane flexible gun mount, Type A, which is adapted from the British Scarff-ring mount, consists of a fixed ring which is bolted to the fuselage over the gunner's cockpit. A revolving ring provided with small rollers fits over the fixed ring and runs on it. The main tube bracket, containing the machine-gun mount socket, is pivoted on the revolving ring.

This bracket may be raised or lowered, and is locked in any position of elevation by the quadrant latch pins, which fit in the teeth of the inside and outside quadrants. The revol-

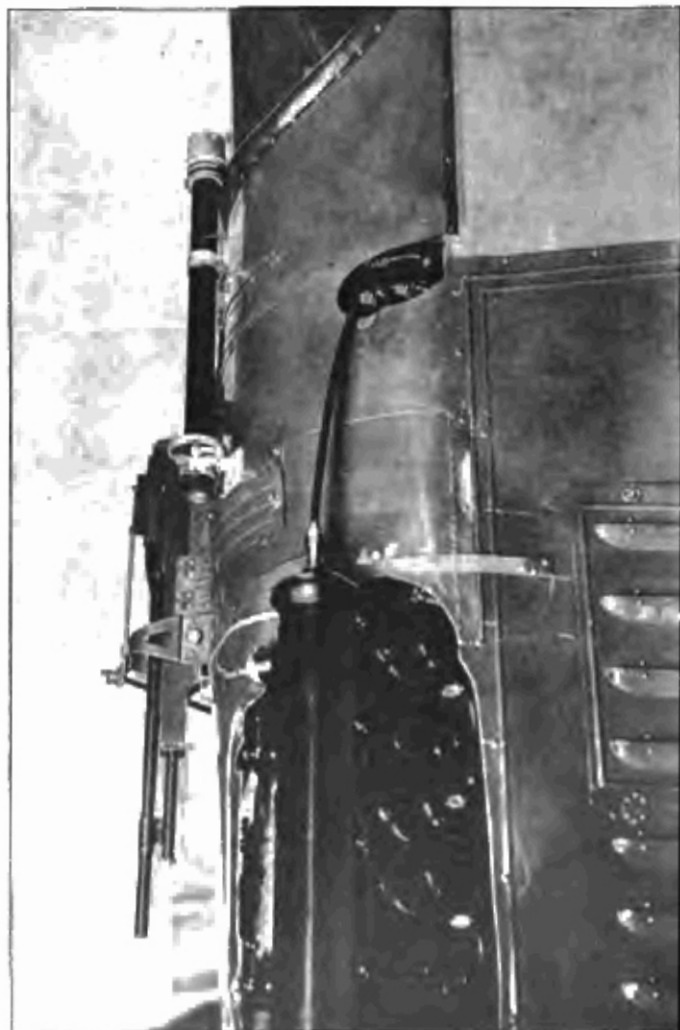


Fig. 23.—FIXED MOUNT FOR ONE MARLIN AIRCRAFT MACHINE GUN ON CURTIS-JN4-HQ, SHOWING UNIT SIGHT, AUXILIARY SIGHT, AND MECHANICAL SYNCHRONIZING GEAR, TYPE H-8.

ing ring is held in position by two plunger stops which are contained in the main tube bracket plates and fit into holes in the fixed ring. The quadrant latch pins and plunger stops are released by means of the Bowden wire lever located under

the machine-gun socket. The weight of the guns is balanced by the exerciser cords, which run under the exerciser cord pulleys on each side of the main tube and over the quadrant hook at the top of the quadrant. This enables the guns to be raised or lowered with ease. The back rest enables the gunner to assist the rotation of the revolving ring with his back.

Inasmuch as the mounting yoke for the gun is fitted with a universal joint, no fine adjustment of setting the airplane flexible gun mount is necessary when bringing the gun into

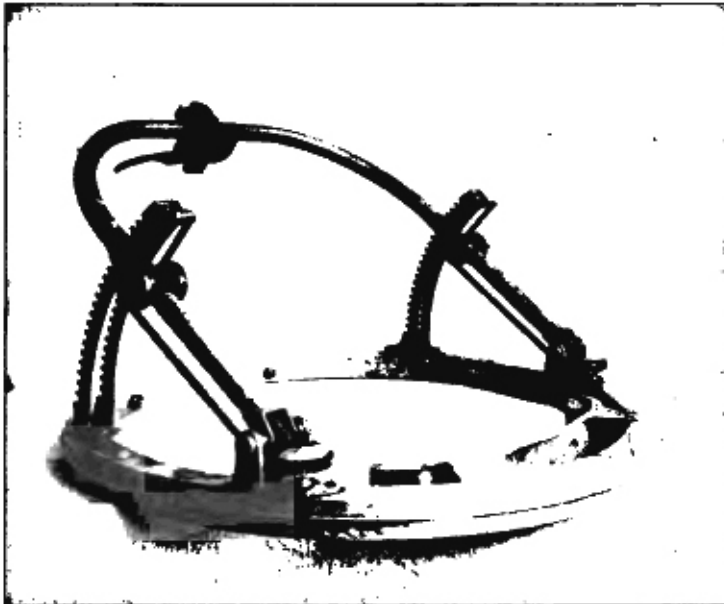


FIG. 24.—AIRPLANE FLEXIBLE GUN MOUNT, TYPE A.

action. Both single and double Lewis gun yokes are adapted for this mount.

SINGLE LEWIS GUN YOKE.

The single Lewis gun yoke (see figs. 25 and 26), is designed for adapting one Lewis gun to the airplane flexible gun mount, Type A. This yoke fits into the socket on the flexible gun mount and permits of the gun being swung through a greater arc, both in a vertical and horizontal plane. A friction sleeve, operated by a hand lever, locks the yoke in the desired position.

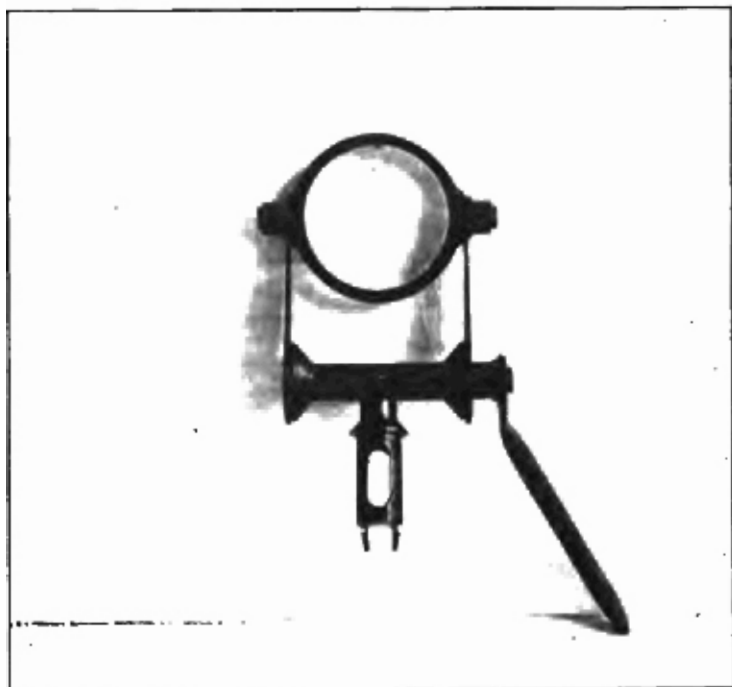


FIG. 25.—SINGLE LEWIS GUN YOKE.

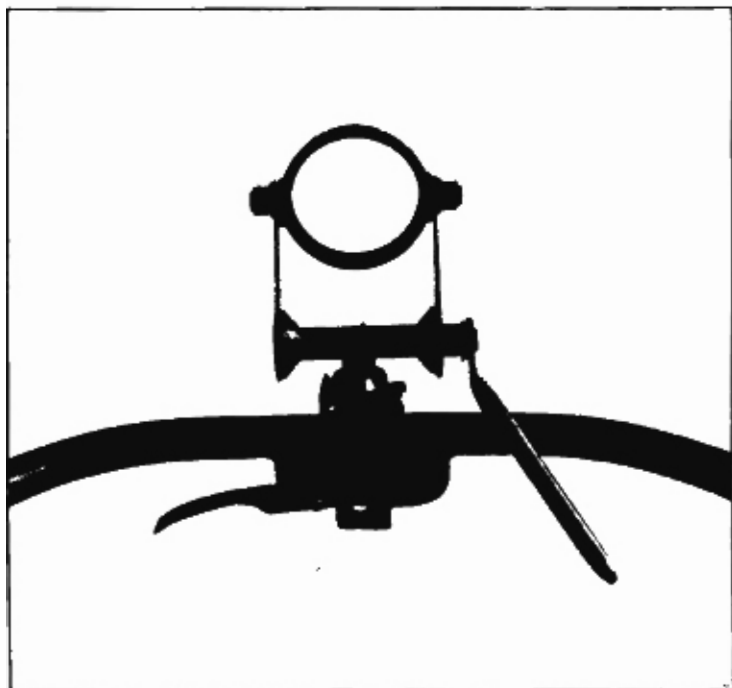


FIG. 26.—SINGLE LEWIS GUN YOKE ON FLEXIBLE GUN MOUNT, TYPE A.

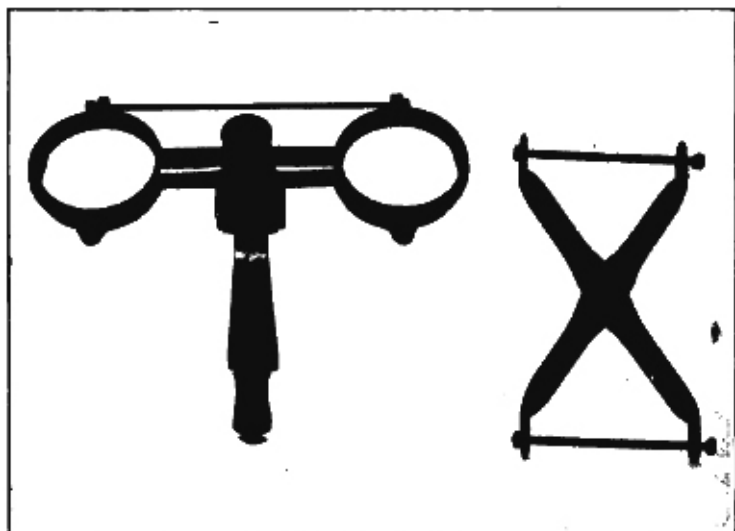


FIG. 26A.—Double Lewis Gun Yoke.

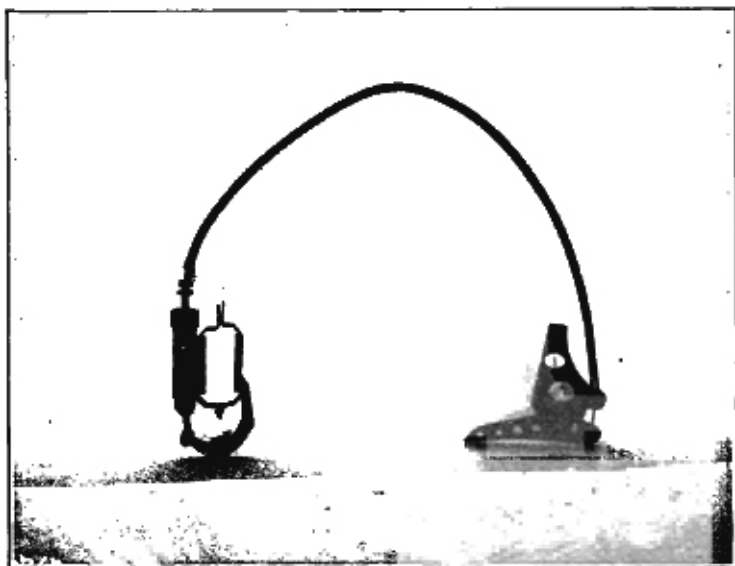


FIG. 26B.—Duplex Trigger Control.

DOUBLE LEWIS GUN YOKE.

The double Lewis gun yoke is designed for adapting two Lewis aircraft machine guns to the airplane flexible gun mount, as shown in figure 27. The yoke, which holds the two guns rigidly side by side, fits into the socket of the flexible gun mount and permits of the two guns being swung through a vertical arc of approximately 315° and through a horizontal arc of 90° , independent of the movement of the flexible gun

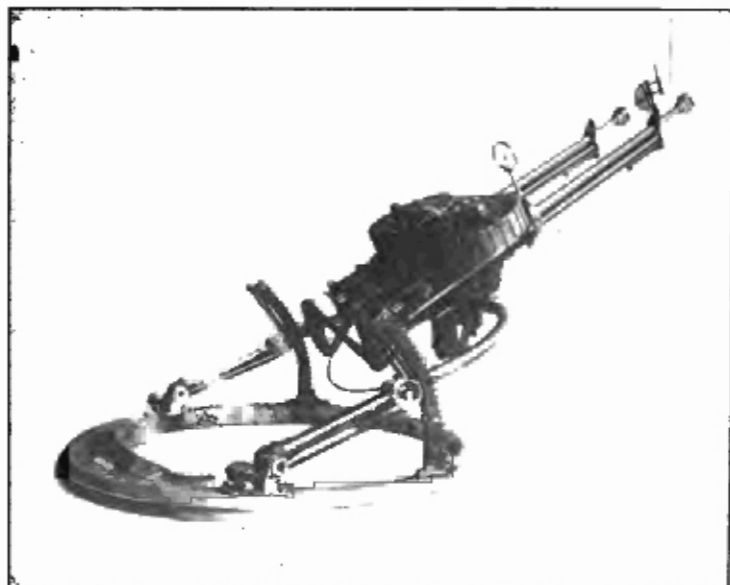


FIG. 27.—DOUBLE LEWIS GUN YOKE WITH GUNS.

mount. In addition to this, the two guns may be tilted to either side about 45° .

This yoke when used with the airplane flexible gun mount makes a very flexible combination, and taking into consideration the additional rate of fire and the increased efficiency of having two guns instead of one, this is an extremely effective and satisfactory mounting.

The Duplex trigger control connects the trigger of one gun by means of Bowden wire to a lever on the trigger guard of the second, so that the trigger of either gun, or both, may be released with one hand.

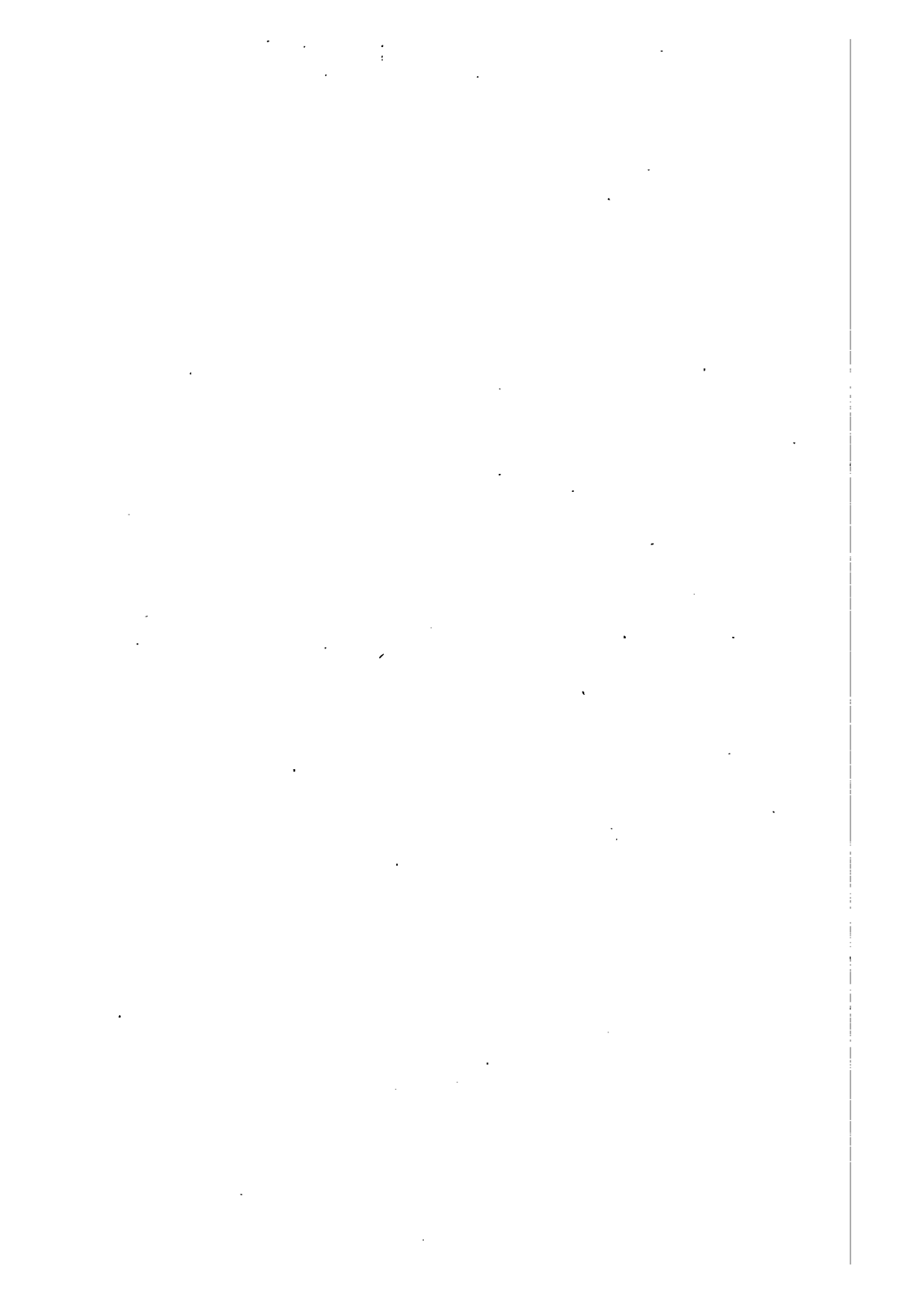
LEWIS MAGAZINE RACK.

The loaded magazines are carried on the DH-4 plane in a rack built in the rear of the gunner's cockpit and extending across the fuselage, as shown in figure 28. It is made of a

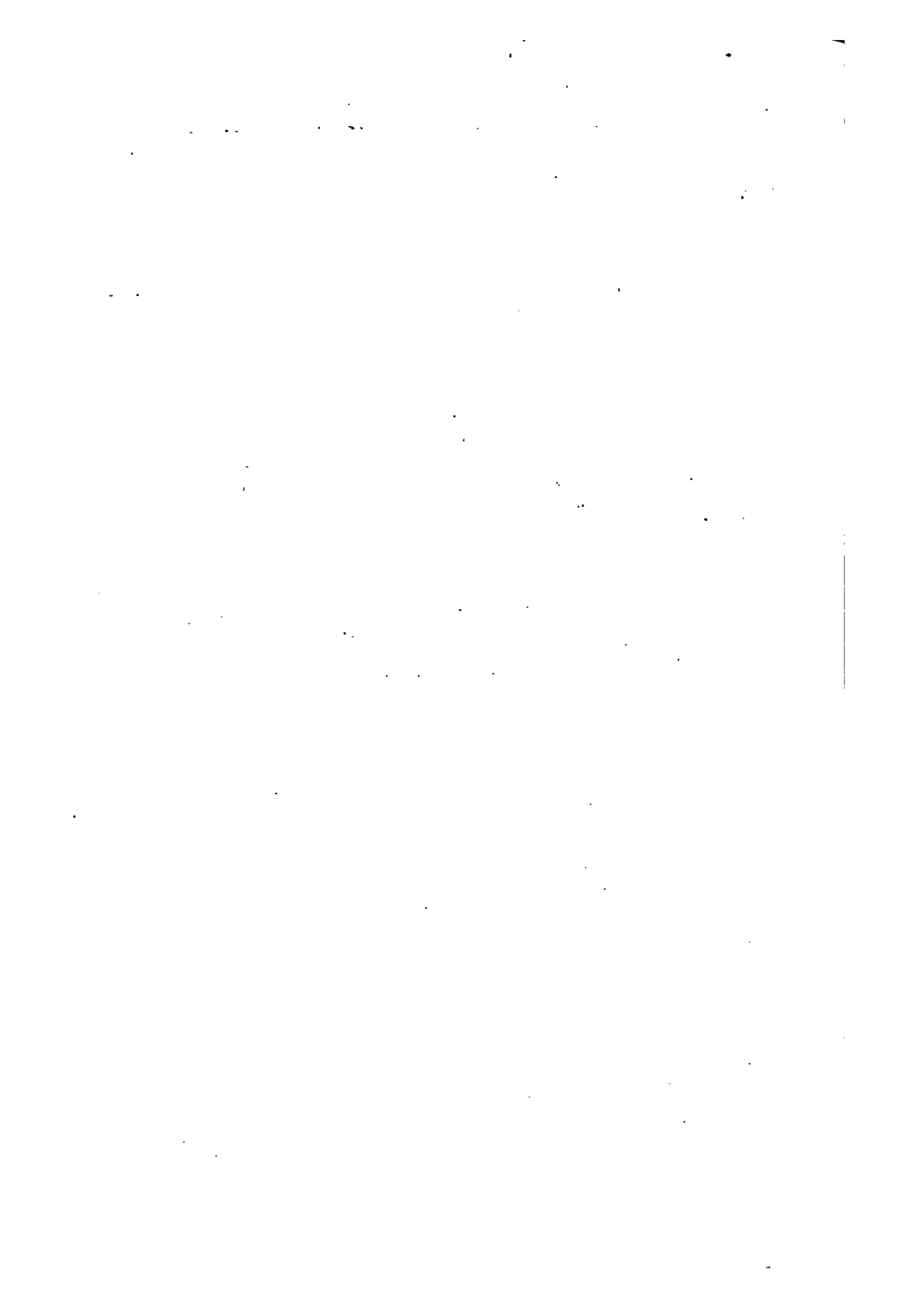


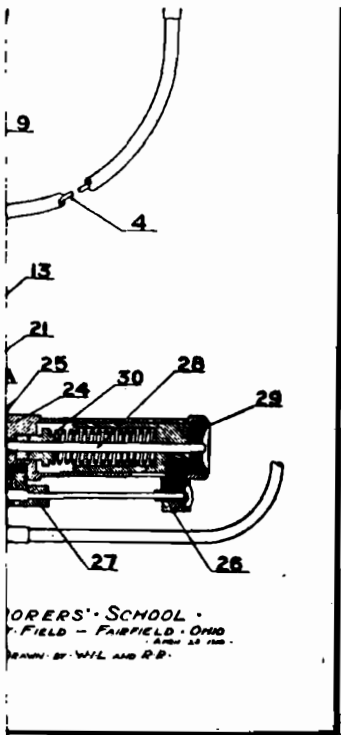
FIG. 28.—LEWIS MAGAZINE RACK.

sheet of aluminum, curved to fit the magazines, and fitted with wood separators forming compartments for eight magazines. A piece of elastic cord stretched between the sides of the fuselage in front of the rack holds the magazines in place and allows their quick removal.









ROBERS' SCHOOL
FIELD - FAIRFIELD - OHIO
DRAWN BY WIL AND R.D.

SECTION D.

SYNCHRONIZERS OR INTERRUPTER GEARS.

A synchronizer or interrupter gear is a device operating between the machine gun and engine of an airplane, which causes the gun to be fired at the proper moment so that the bullets will not strike the revolving propeller. Only fixed guns can be synchronized. Originally, fixed guns were timed to fire between the blades of the propeller by a device which interrupted the gun at the moment the blade passed the muzzle of the gun. However, this was found to be very unsatisfactory, owing to the construction of the gun, and it was found that a much more satisfactory operation could be obtained by having a gear fire the gun at certain points throughout the revolution of the propeller when the blade was not opposite the muzzle of the gun.

There are two kinds of synchronizer or interrupter gears:

1. Mechanical.
2. Hydraulic or C. C.

The mechanical gear is a system of rods actuated by cams on the engine which are timed to fire the gun at the proper moment.

The hydraulic, or C. C. type of gear consists of a system of copper tubes filled with oil under high pressure. A cam on the engine generates an impulse at one end of the tube which is conveyed through the column of oil to the trigger motor of the machine gun, causing it to fire at the proper moment.

Great care must be taken with all synchronizing devices to see that the cam is timed to fire the gun at the proper instant. The gun should shoot just as the trailing edge of the propeller passes the muzzle of the gun.

Proper synchronizing can be carried out only on machine guns having a single shot trigger; that is, a trigger which when pressed will permit of only one shot being fired until released and pressed again.

The Marlin, Browning, and Vickers guns have been fitted with single-shot triggers and successfully synchronized; but the Lewis has not as yet been satisfactorily adapted as a fixed gun.

The mechanical gear necessitates less care than the hydraulic type, as it is only necessary to keep it oiled and properly timed. It is possible that in the near future hydraulic gears will be discarded in favor of the mechanical. The hydraulic type must be constantly inspected for leaks; and if air bubbles form in the tube the timing is apt to be seriously affected, resulting in the shots striking the propeller.

After long flights the synchronizing gear cams should be carefully inspected for wear, and the gun should be retimed. Wear on the cams results in late timing and causes stray shots.

HYDRAULIC, OR C. C., SYNCHRONIZING GEAR.

The hydraulic synchronizing gear, commonly known as the C. C. interrupter gear, is named after the inventor, Mr. Constantinesco. The following principal parts are embodied in this gear:

1. Reservoir.
2. Generator—furnished with engine by engine manufacturers.
3. Trigger motor.
4. Control lever.
5. Pipe system.

The reservoir is connected to the generator on the engine by a copper tube of small diameter, about one-sixteenth inch. A larger tube, three-eighths inch diameter, runs from the generator to the trigger motor on the gun. The cam in the generator is arranged so that it raises the plunger in the generator to its highest point just as the trailing edge of the propeller passes the muzzle of the gun.

ACTION.

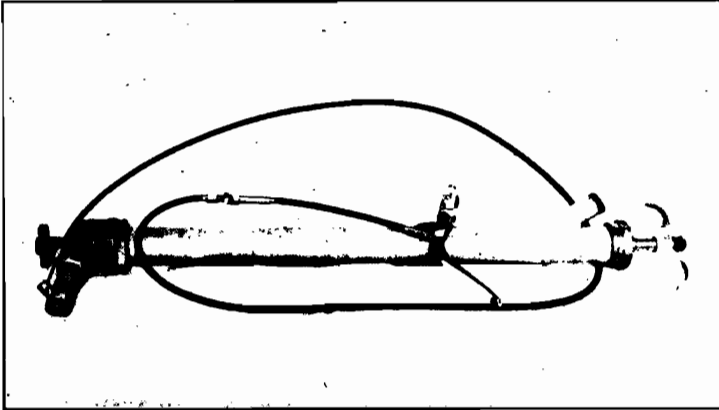
The piston in the reservoir is withdrawn to its farthest point, thereby placing the oil in the reservoir under high pressure. A wire from the control lever connects with a valve at the lower end of the reservoir and opens this valve when the lever is pulled. This causes the high pressure to travel along the tube to the generator and forces the plunger down on the cam. The rise on the cam lifts the plunger, and in so doing imparts an impulse to the oil which travels along the line of least resistance in the larger tube, and presses the plunger in the trigger motor, thereby firing the gun.

The great advantage of this type of gear is that it is so easily adapted to any type of engine or airplane owing to the fact that the copper tubes can be bent around any obstacle and placed wherever convenient. Owing to the steel rods, etc., of the mechanical gear, this flexibility can not be obtained and the gear has to be specially designed for each type of engine and airplane to which it is to be adapted.

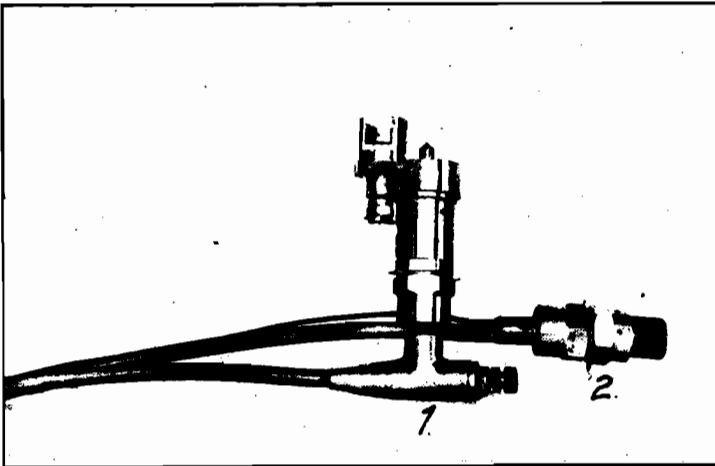
MECHANICAL SYNCHRONIZING GEAR, TYPE HS.

The mechanical synchronizing gear type HS is designed for use in connection with the Hispano Suiza engine, having

been in use for some time on the French Spad, and now adapted for the Curtiss JN4-HG training plane.



Reservoir and Bowden wire control.



1. Old type trigger motor.
2. Generator piston and cylinder.

FIG. 29.—HYDRAULIC SYNCHRONIZING GEAR.

Either one or two guns may be synchronized with this engine, as it will accommodate two of the type HS gears, one attached to either cam shaft.

DESCRIPTION.

The gear consists of a circular 4-point cam fastened to the end of the engine cam shaft. A push pin bearing against the cam actuates a rod, which in turn actuates another rod



Fig. 30.—MECHANICAL SYNCHRONIZING GEAR, TYPE H-8, AS MOUNTED ON CURTISS JN-4 H.C.

fastened above the gun and bearing against the trigger. The firing of the gun is controlled by a Bowden wire lever attached to the control stick of the airplane. When the control lever is pulled, a tappet is placed in line with the push pin and the rods are actuated, thereby firing the gun.

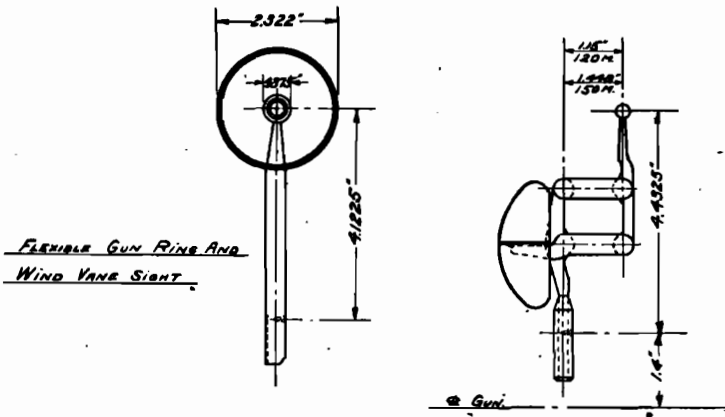
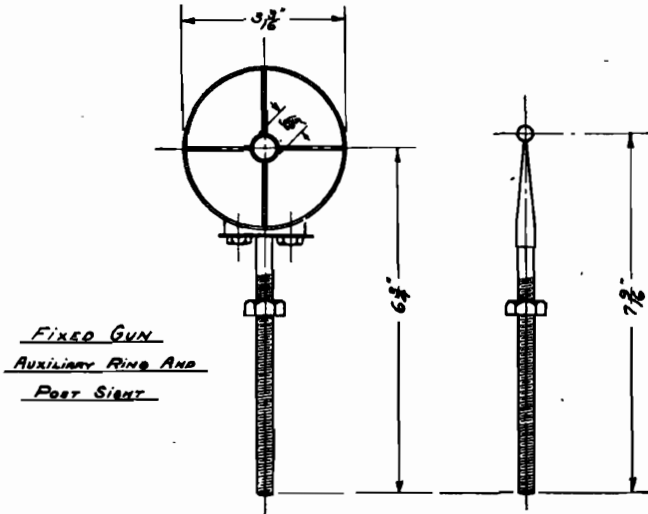


FIG. 30A.

SECTION E.

AIRCRAFT MACHINE-GUN SIGHTS.

THEORY OF AUXILIARY RING AND POST SIGHT.

It may readily be seen that if the eye is placed at a certain distance behind a ring, an angle is subtended by the diameter which is proportional to it and which increases or decreases as the eye is moved nearer to or farther away from the ring. In making use of a ring for a machine-gun sight, for any size of ring, the distance from the eye can be determined so that if the gun is fired just as an enemy machine cuts the ring when flying at right angles to the line of sights, a hit will be scored, assuming, of course, that the elevation of the gun is correct for the range.

It must be remembered that the bead is used only to align the eye with the center of the ring and may be placed either behind or in front of the ring and at any distance from it.

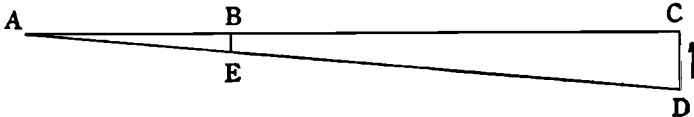


FIG. 31.

In the above figure, the eye is placed at A, a distance behind the center of the ring B, such that when the enemy machine appears at D, just cutting the ring at E, the gun is fired and scores a hit at C.

Let AB = Distance of eye from ring in inches.

D = Radius of the ring sight in inches.

AC = Range, which is
Inches projectile will travel in 1 second.

CD = Distance the enemy machine will travel in 1
second at 110 miles per hour.

From similar triangles:

$$\frac{AB}{BE} = \frac{AC}{CD}, \text{ or}$$

$$AB = \frac{AC \times BE}{CD}$$

For a 3-inch ring, range of 2,650 feet, and enemy speed of 110 miles per hour:

$$AB = \frac{1.5'' \times 31800''}{1936''} = 24.1''$$

This gives the correct method of determining the distance of the eye from the ring under the conditions given. This distance varies inversely as the speed of the enemy machine; and for enemy speed of greater than 100 miles per hour, the distance AB should be decreased and vice versa. In actual practice, however, the sights are placed at a certain distance from the eye, which is based on an average value of the enemy speed, and for any speed greater or less than this, the gun is fired when the enemy machine is just inside or outside the ring. The bead is fixed at such a height in relation to the center of the ring sight that the elevation is correct for 200 to 300 yards.

We have thus far considered only the case of an enemy machine flying at right angles to the line of sight. For any other direction of enemy flight, the part to be hit, usually the forward part of the fuselage, should be placed within the ring at a point determined by the enemy direction and varies from a point on the ring for the condition considered above to a point at the center for an enemy flying directly toward or away from the gunner. The intermediate positions may be determined from the appearance of the enemy machine, that is, from the foreshortening of the body.

It is of greatest importance that in every case the enemy airplane is placed so that the head of the airplane is pointing accurately toward the center of the ring.

AUXILIARY RING AND POST SIGHT.

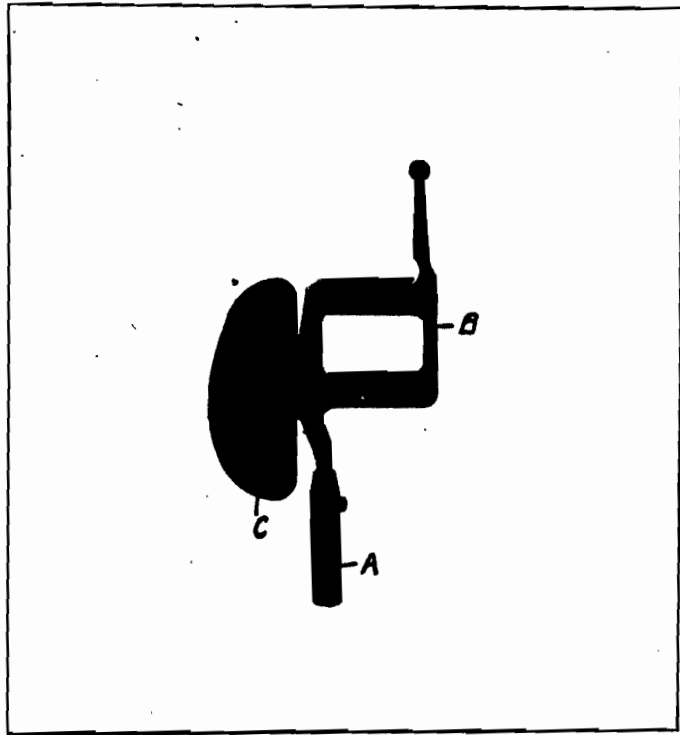
This is a ring and post sight to be used in conjunction with, or instead of, the unit sight on fixed guns. The set consists of a post mounted in a convenient position and a ring, the diameter of which is so calculated that when placed at a fixed distance from the pilot's eye, it will correspond to the graticulation on the lens of the unit sight and afford correction in the sighting of the gun. (See Theory ring and post sight.)

Figure 22 shows an auxiliary sight as mounted on a De H 4.

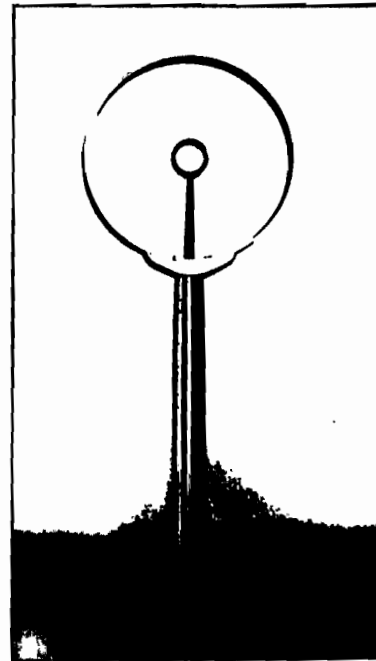
WIND-VANE SIGHTS.

The wind-vane sight is used as a front sight in connection with a ring sight, on machine guns mounted on flexible mounts.

The purpose of this sight is to correct for the speed of the gunner's machine and when used with the ring sight, which corrects for the speed of the enemy machine, a very good combination is obtained.



Wind vane sight.



Ring sight, as used with wind vane sight.

FIG. 32.—SIGHTS FOR FLEXIBLE GUN.

Description: The bead sight on post B is off-set from the main pivot A, which is fixed perpendicular to the axis of the gun. The vertical and horizontal vanes C, keep the bead "B" into the wind at all times, no matter what the position of the gun. The distance from pivot A to post B was calculated in the following manner:

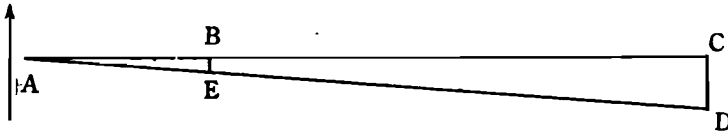


FIG. 33.

In figure 32 let A = The position of the rear sight.

AB = A convenient distance on the gun for the wind vane sight from the ring sight.

AC = Distance traveled by the bullet in 1 second.

C = The target.

CD = The distance the gunner's machine will travel in 1 second.

It will be seen from figure 33 that if A is traveling in the direction of arrow with a speed of CD, to hit the target C, it will be necessary to aim gun along AD. Therefore the required correction is BE, which is easily found by proving the equilateral triangles ABE and ACD, since—

$$\frac{AC}{AB} = \frac{CD}{BE}$$

Wind-vane sights are made for the following speeds: 90 miles per hour, 120 and 150 miles per hour. The 90-mile-per-hour sight is for speeds between 80 and 100 miles-per-hour sight. The 120 mile-per-hour sight is for speeds between 110 and 130 miles per hour, and the 150 mile-per-hour sight is for speed between 140 and 160 miles per hour.

UNIT SIGHT.

The unit sight is an optical sight consisting of a tube, approximately 2 inches in diameter and 25 inches in length, containing a system of lenses so designed as not to magnify or diminish any object which is looked at through it. Within the tube is a glass screen carrying the sighting ring, which is so placed between the lens, that, on looking through the tube at a distant object, the ring is seen with its center on the

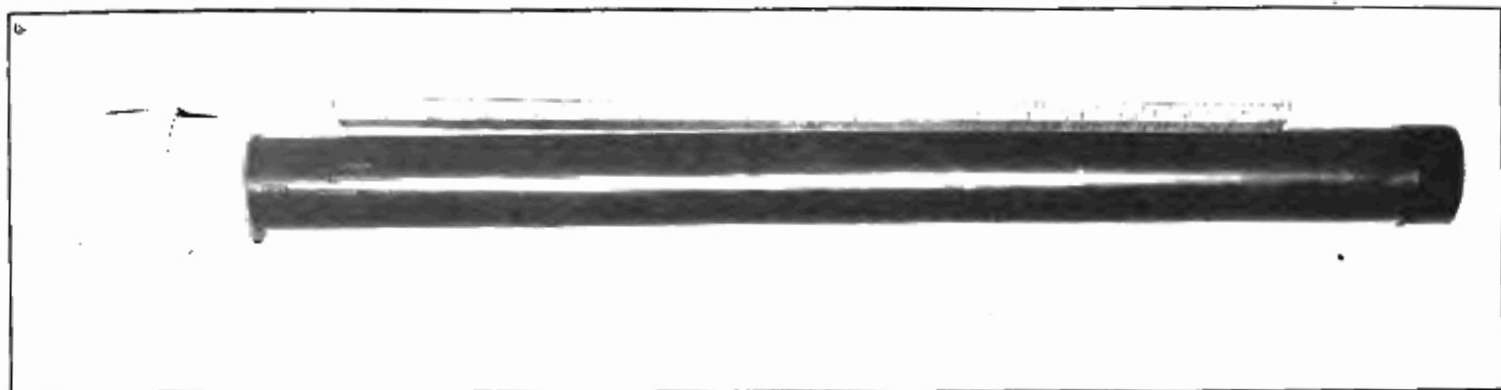
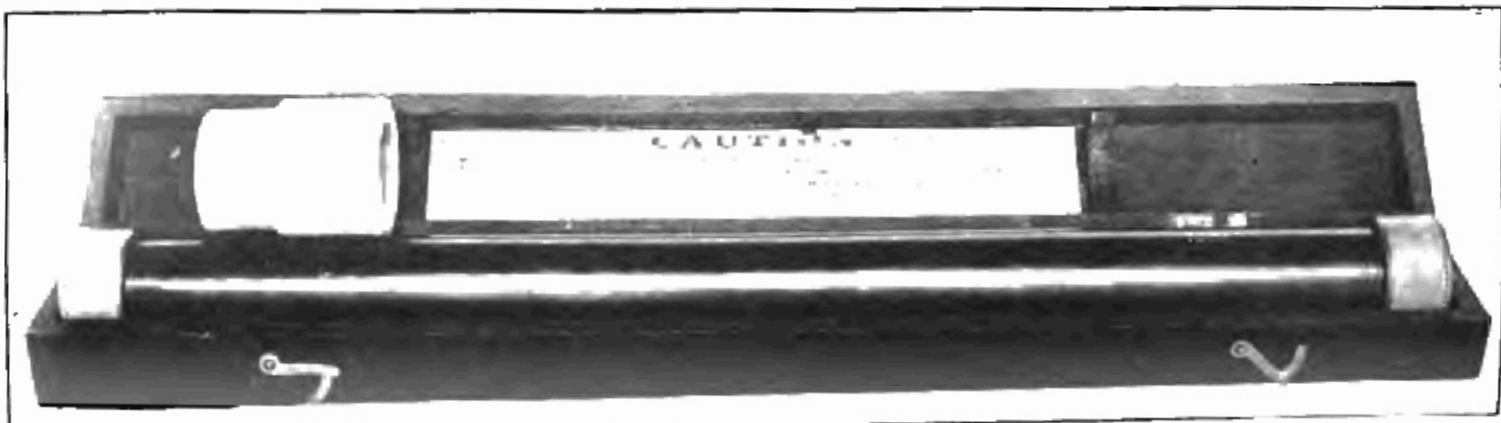


FIG. 34.—UNIT SIGHT.



spot at which the tube is pointing irrespective of where the eye is placed.

This tube, when fixed rigidly, constitutes a sight which offers practically no obstruction to the view and shows instantly the spot at which the gun is pointing, without the necessity of aligning the eye upon a front and back sight.

The above diagram shows the graticulation on the lens of the unit sight. The size of the larger ring in proportion is calculated in the same manner as in the auxiliary sight.

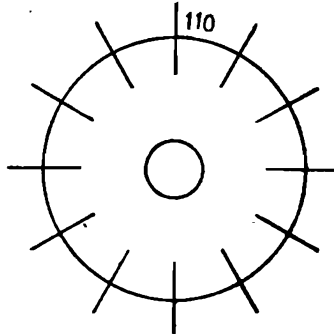


FIG. 36.

The number on the graticulation indicates the approximate speed of the enemy airplane for which the sight is calculated.

SIGHT MOUNTINGS.

[See fig. 22.]

The mountings for the unit and ring and bead sights for the fixed guns on the DH-4 plane consist of brass sockets secured to the cowl by two small bolts. The sockets are threaded to take the five-sixteenths-inch post of the sight bracket, which is clamped by means of a nut and lock washer. The method of lining up the sights has already been described. (See page 61.)

Care should be taken in adjusting the sights not to turn the stem by means of the ring, as it is very liable to become bent or twisted off. Pipe pliers should be used on the stem above the threaded part.

AERIAL DROP BOMBS.

Aerial drop bombs are divided into classes according to the use for which they are intended. There are three general types, viz, high-capacity (demolition), fragmentation, and incendiary, all of which have been designed and equipped to meet the requirements abroad. Changes are constantly being made in details, such as the method of suspension, to make possible the use of the bombs in new release mechanisms and planes.

High-capacity drop bombs, so called because of the large ratio of the weight of the explosive to the weight of the casing, are used for general demolition purposes. The targets engaged include fortified positions, railroad terminals and lines, heavy structures of all kinds, supply depots, ammunition dumps, etc.

Fragmentation bombs are used against personnel, such as troops in the field or on the march, or wherever the protection afforded is slight. These bombs carry a relatively small charge of explosive in a heavy steel casing and depend for their effect on the fragmentation of this casing.

Incendiary bombs are used for incendiary purposes against ammunition dumps, aerodromes, grain fields, etc. There are two types, the scatter and the intensive.

Dummy drop bombs are used for instructional purposes.

SAFETY FEATURES.

All bombs of the above types are provided with a safety feature which consists of a pin so arranged that when left in the bomb no explosion will take place when the bomb is dropped, but if pulled out the bomb will explode on contact.

HIGH-CAPACITY DROP BOMBS.

	Total weight.	Weight of charge.	Length.	Diameter.
	<i>Pounds.</i>	<i>Pounds.</i>	<i>Inches.</i>	<i>Inches.</i>
Mark I.....	104	52	47	7½
Mark II.....	22	9½	28.25	4.75
Mark III.....	51.5	24	38	6



FIG. 37.--HIGH CAPACITY BOMB MARK 1.
(Weight, 104 lbs.; length, 47 in.)

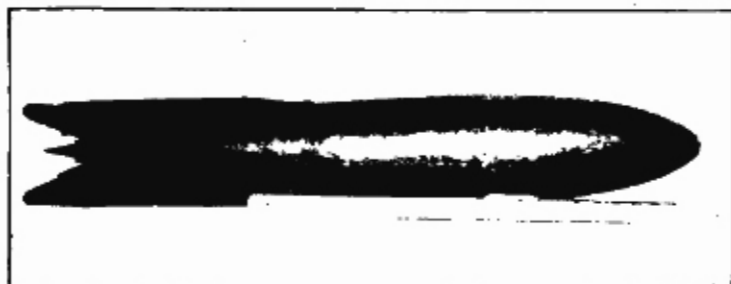


FIG. 38.—HIGH CAPACITY BOMB—MARK III.
(Weight, 50 lbs.; length, 36 in.)

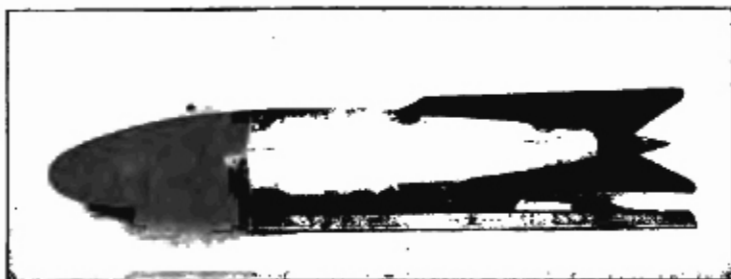


FIG. 39.—INCENDIARY BOMB—MARK II (INTENSIVE TYPE).
(Weight, 46 lbs.; length, 36 in.)

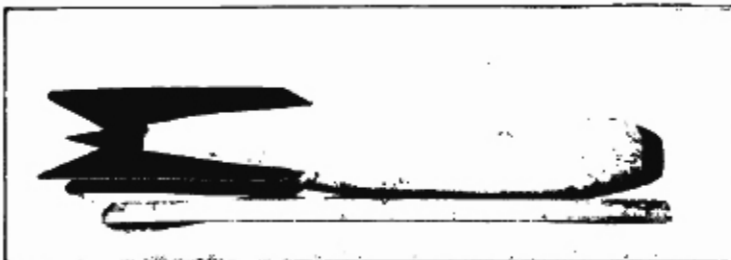


FIG. 40.—DUMMY BOMB—MARK I.
(Weight, 22 lbs.; length, 27 in.)

The Mark I high-capacity bomb is provided with two new type firing mechanisms, one in the tail and one in the nose; the latter may be omitted when desired. These firing mechanisms may be arranged to explode instantaneously or after a delay of one-fourth second or two seconds. This bomb is provided with a nose loop for vertical suspension, two side carrying loops for the American suspension, and an auxiliary loop on the side for the British horizontal release mechanisms. It may also be carried in the Mark V release.

The Mark II and III high-capacity bombs are provided with a single firing mechanism near the tail. This consists of a movable member, carrying the primer and detonator, which upon release from the plane slides down a central tube until it rests on the firing pin. On contact the detonator is driven forward and the firing pin sets off the primer.

	Total weight.	Weight of charge.	Length.	Diameter.
	<i>Pounds.</i>	<i>Pounds.</i>	<i>Inches.</i>	<i>Inches.</i>
Mark IV.....	200	120	47.25	12.20
Mark V.....	550	280	59.04	16.53
Mark VI-A.....	1,000	500	62.75	20.875

The Mark IV, V, and VI-A high capacity bombs are provided for the heaviest grade of demolition work. They are provided with two firing mechanisms, one in the nose and one in the tail, and with two side carrying loops for the American release mechanism in addition to one side loop for adaptation to the British release mechanism. The Mark IV is also provided with a nose loop for the British vertical release mechanism.

The Mark I-A and V-A high capacity bombs are similar in details to the Mark I and V, respectively, except that heavier casings are used throughout.

The Mark IV-A, high capacity drop bomb, also has a heavy casing and with the exception of the firing mechanism is a duplicate of the French 100 kilo bomb.

FRAGMENTATION BOMBS.

	Weight.	Weight of charge.	Length.	Diameter.
	<i>Pounds.</i>	<i>Pounds.</i>	<i>Inches.</i>	<i>Inches.</i>
Mark I.....	94	13½	58.3	6
Mark II.....	19	1½	30.1	2.925
Mark II-A.....	19	1½	30.2	3
Mark III.....	49	6	50.38	4.7

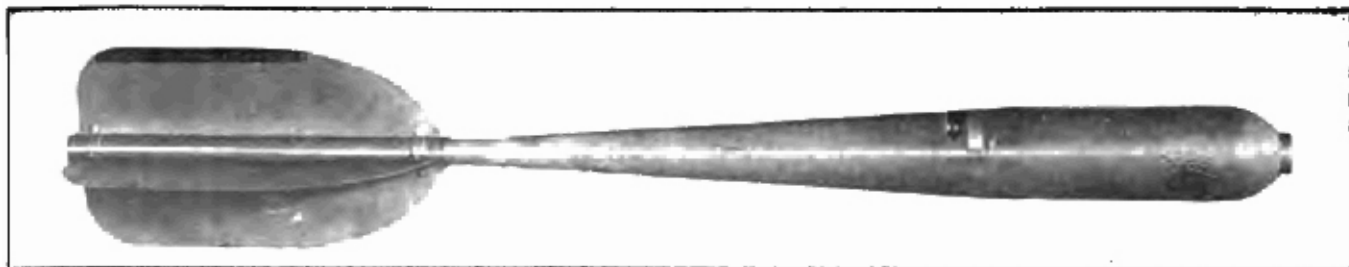


FIG. 41.—BARLOW HEAVY DROP BOMB.
(Weight, 95 lbs.; length, 80 in)



FIG. 42.—BARLOW HEAVY DROP BOMB EXTENDED.
(Length extended, 15 ft.)

The above fragmentation bombs are provided with a nose firing mechanism so arranged as to cause the bomb to explode above the ground, and cause a lateral dispersment of the fragments over an area of 40 yards or more in diameter. All the above bombs are intended for horizontal release. The Mark II and II-A are also provided with a loop at the tail by means of which they may be carried in the British release for the Cooper Bomb.

MARK II-B FRAGMENTATION BOMB.

The Mark II-B fragmentation bomb is a copy of the English Cooper bomb.

BARLOW HEAVY DROP BOMB, MODEL 1917.

Diameter.....	6 in. (155 m/m).
Length of shell.....	18 in. (465 m/m).
Total length.....	80 in. (2,040 m/m).
Weight.....	95 lbs. (43 kg.).

This bomb consists of a war head or shell of forged steel containing 13 pounds (6 kg.) of high explosive. To this war head is connected a compressed air mechanism of pressed steel and brass tubing, which is composed of a forward extrusion rod carrying the firing mechanism and a sliding stabilizer mounting which moves to the rear. On release from the plane the compressed air in the air chamber is released and drives the stabilizer tube back and the firing mechanism forward until the latter extends about 6 feet (2 meters) in front of the war head. On contact a service cartridge carried in the front end of the extruded tube is discharged; the bullet passes up the tube and strikes a primer in the detonator which explodes the war head when it is between 4 and 5 feet above the ground. The bomb is to be used against personnel in the field or on the march or wherever the protection afforded is slight.

INCENDIARY BOMBS.

	Total weight.	Weight of charge.	Length.	Diameter.
	<i>Pounds.</i>	<i>Pounds.</i>	<i>Inches.</i>	<i>Inches.</i>
Mark I.....	40	21	36	6
Mark II.....	46	26	36	6
Mark III.....	100

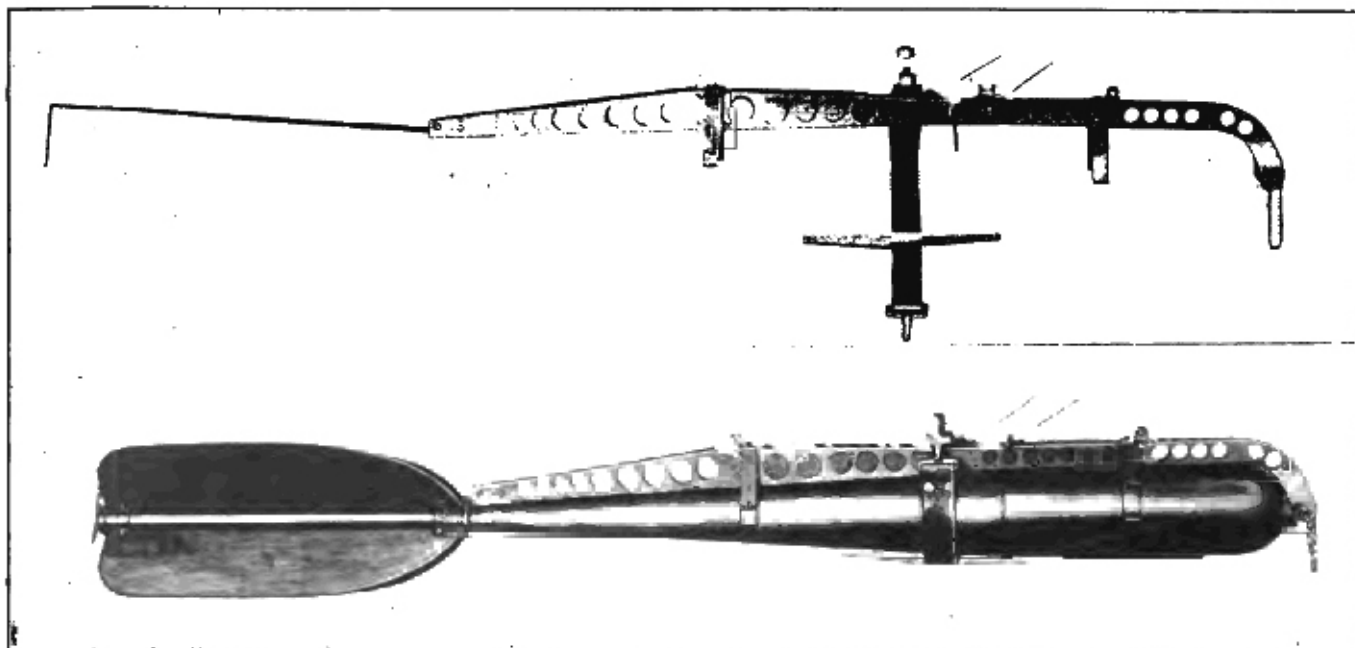


FIG. 43.—BARLOW HEAVY DROP BOMB AND RELEASE MECHANISM.

The incendiary drop bomb Mark I is of the "scatter" type and is for use against grain fields, light wooden structures, and wherever better results can be obtained by scattering the incendiary material over a larger area. It carries a charge of 1½ pounds of black powder and 19 pounds of cotton waste balls soaked in turpentine, or solid oil balls wrapped in burlap. Two firing mechanisms are provided, one in the nose and one in the tail. This bomb is carried in the horizontal release mechanism.

The incendiary drop bomb Mark II is of the "intensive" type and is designed for use against structures which require a higher degree of igniting power. This bomb has a charge of 10 pounds of thermit and 16 pounds of oil emulsion. The tail firing mechanism is the same as in the Mark I incendiary. An auxiliary nose loop is provided for use in the vertical release and the bomb may also be carried in the horizontal release.

The incendiary drop bomb Mark III at present under development is very similar to the Mark II incendiary. The dimensions of this bomb will be the same as of the Mark I high capacity bomb.

DUMMY DROP BOMBS.

	Total weight.		Length.	Diameter.
	Lbs.	kg.	Inches.	Inches.
Mark I.....	22	10	27	4½

This bomb, which is designed for instructional purposes, is made with a central tube covered with concrete or terra cotta in the same size and shape as the Mark II high capacity bomb. In the central tube is placed a small type of point detonating mechanism; a smoke producing cartridge is thus set off which aids in locating the bomb after it has been dropped.

MARKING OF BOMBS.

The type of bomb is stamped on a brass name plate on the Barlow bomb and stenciled in black on the other types.

High-capacity drop bombs, Mark I, II, III, IV, V, and VI: Color, olive drab; center of gravity marked by 1-inch black band.

Barlow heavy drop bomb: Color, olive drab; center of gravity marked by 1-inch black band.

Fragmentation bombs, Mark II and III: Color, olive drab; one 1-inch blue band 3 inches from tip.

Incendiary drop bomb, Mark I: Color, olive drab; one 1-inch red band 3 inches from tip.

Incendiary drop bomb, Mark II: Color, olive drab; two 1-inch red bands 3 inches from tip, 2 inches apart.

Dummy drop bomb, Mark I: Color, black.

PACKING OF BOMBS.

High-capacity drop bombs:

Mark I, in a case.....	1
Mark II, in a case.....	3
Mark III, in a case.....	2
Mark IV, V, VI, in a case.....	1

The detonator, in a sealed tin container, is carried in the compartment provided for it in the shipping case with the bomb. The cover of the detonator compartment is painted red when the detonator is loaded and left unpainted when it is not loaded.

Barlow heavy drop bomb: Packed 1 in a case. The detonator, in a sealed tin container, is carried in a separate compartment.

Fragmentation bombs:

Incendiary drop bombs:

Mark I, in a case.....	2
Mark II, in a case.....	2

The powder charge for each Mark I bomb is put in a tin powder can and fastened in the shipping case with the bomb. This can is $15\frac{1}{2}$ inches long and $1\frac{1}{8}$ inches in diameter and is carried in the forward end of the shipping case under the nose of the bomb.

The nose firing mechanism for the Mark I bomb is carried in a compartment directly over the powder can.

Two powder charges and two firing mechanisms are carried in each shipping case, one for each bomb.

Dummy drop bomb, Mark I: Packed 3 in a case. The outside of each case is marked with a stencil denoting the kind of bomb contained therein.

STORAGE OF BOMBS.

Bombs should be stored in a structure which is bomb-proof and kept as cool and dry as possible to prevent the deterioration of the explosive charge.

SECTION G.

BOMB RELEASE MECHANISMS.

All bombs are carried in some sort of release mechanism attached to the airplane. There are two types of release mechanism—vertical and horizontal; the vertical type is usually installed on the inside of the fuselage and the horizontal type is usually hung from the lower wings. The horizontal type is the more common type employed and is found in batteries of a number of traps depending on the kind of bomb used, an equal number suspended from each bottom wing.

The function of the trap is to carry the bomb in a safe condition, permit of its release at the desired time, and provide for the removal of the safety device at the time of release.

The different types of release mechanisms and the method of operation and installation are described in detail in the handbooks given in the "List of reference books."

Bomb release mechanisms, as of August 12, 1918.

Mark.	Plane.	Location.	Type.	Bombs carried.	Remarks.
I	De Haviland 9.	Abandoned Aug. 19, 1918
II	Handley-Page.	In fuselage....	Horizontal	16 Mark I H. C. or 9 Mark IV H. C.	
III	Caproni.....do.....do.....do.....	Similar to Mark II release.
IVdo.....	Under fuselagedo.....	2 Mark V H. C.....	Similar to Mark IX-A release.
V	De Haviland 4.	Under wings..do.....	10 Mark II H. C. or 6 Mark III H. C. or 4 Mark I H. C.	
VIdo.....do.....do.....	Same as Mark V.
VII-B	JN4-HB training.	Under fuselagedo.....	5 Mark II H. C. or 3 Mark I H. C. or 3 Mark III H. C.	
VIII-A	De Haviland 9.	Under wings..do.....	Same as Mark V release.	
IXdo.....	Under fuselagedo.....	1 Mark I H. C. or 2 Mark III H. C. or 1 Mark IV H. C.	
IX-A	Handley-Page.do.....do.....	2 Mark V H. C.....	
X	Under wings or fuselage.do.....	4 Mark II-B fragmentation (Cooper).	"English quad. Cooper bomb carrier."
XI	Under fuselagedo.....	1 Mark IV-A H. C..	For French 100 kilo bomb.
XII	Handley-Page.	In fuselage....	Vertical...	Mark I H.C., French 50-kilo., English 112-pound H. C.	

It must be understood that this table is subject to change.



FIG. 44.—MARK V BOMB RELEASE MECHANISM ON DE HAVILLAND 4.

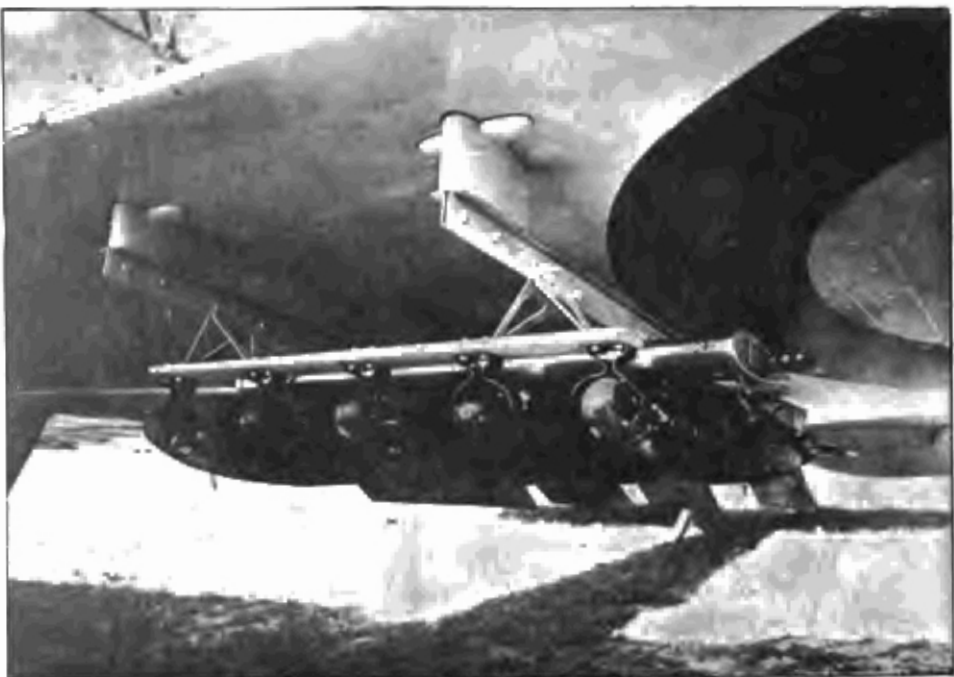


FIG. 45.—MARK V BOMB RELEASE MECHANISM ON DE HAVILLAND 4.

In all types of horizontal release mechanism now used the bomb is supported by a strap around the body and steadied by means of nose and tail clips. One end of the strap is fixed to the frame of the trap and the other end is held by some form of trigger which permits of its release.

Care must be taken to see that the release mechanism is kept in proper working order, and it should be tested before attaching the bomb. All working parts should be kept clean and covered with a thin coating of oil.

MARK V BOMB RELEASE MECHANISM.

METHOD OF INSTALLATION.

The Mark V bomb release mechanism is attached to the DH-4 plane by means of four pairs of eyebolts—two pairs straddle the main spar and two pairs straddle the rear spar.

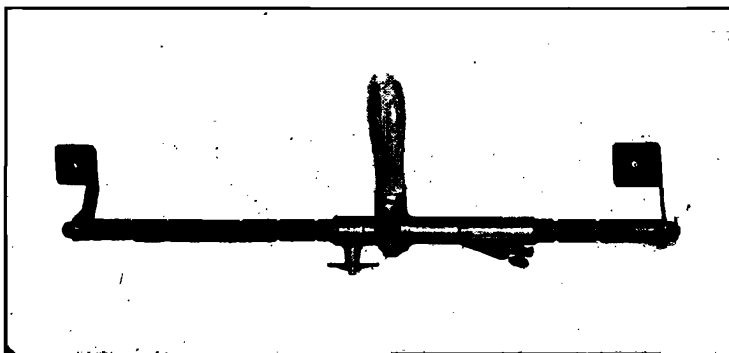


FIG. 46.—OPERATING HANDLE FOR MARK V BOMB RELEASE.

Each eyebolt is attached to the frame of the release by a bolt through the eye and bolted through an aluminum plate above the spar. In order to suspend the release below the wing the bolts pass through wood blocks stream-line shaped to reduce air resistance.

"*trail*." The angle FRS, denoted by (b) is called the "*trail angle*." Now let the speed of the airplane relative to the ground be denoted by s , and let the time required for the bomb to fall be denoted by t . Then

$$PR = OS = st$$

Therefore

$$OF = OS - FS = st - FS \quad (1)$$

The angle OPF denoted by a is called the "*aiming angle*." It is given by the equation

$$\tan a = \frac{OF}{OP}$$

Let the altitude OP be denoted by h and substitute from equation (1) for OF.

Then

$$\tan a = \frac{OF}{h} = \frac{st - FS}{h} = s \frac{(t)}{(h)} - \tan b, \quad (2)$$

since

$$\frac{FS}{h} = \tan b.$$

Then equation

$$\tan a = s \frac{(t)}{(h)} - \tan b \quad (3)$$

is fundamental in the designing of all bomb sights.

Let v denote the speed of the airplane through the air, and w the speed of the wind relative to the earth, then obviously, flying directly with the wind, we have

$$s = v + w$$

and directly against the wind

$$s = v - w$$

For all bombs of the same size, shape, and weight, the time of fall t depends on the altitude h and the air speed v , but varies so little with v that it is commonly assumed to depend on h alone. The angle b depends on the air speed v and the altitude h , but is entirely independent of the ground speed. But b varies so little for the ordinary air speed and altitudes encountered in practice that it is sometimes assumed to be constant.

It is plain that the "*aiming angle*" (a) depends on only three quantities, h , v , and s , for in equation (3) t and b depend on h and v . In actual bombing the altitude is determined by an altimeter, and air speed by an air speed indicator,

while the ground speed must be determined by some device incorporated in the sight.

The fundamental requirements of a bomb sight are, therefore:

1. To be so designed that when the three fundamental quantities h , v , and s are known, the sights may at once be set at the proper "aiming angle" a .

The actual operation of the different types of bomb sight, together with the method of installation on aircraft, is described in detail in the handbooks issued by the Ordnance Department.

In any case at the time of release the machine must be flying in a vertical plane passing through the target, and,

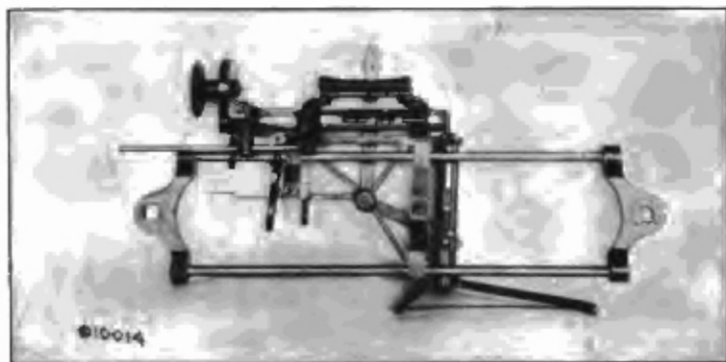


FIG. 48.—MARK I-A BOMB SIGHT.

except in the case of the synchronizing sight, must be flying on an even keel. Bombing is practically always done when flying either up or down wind.

As has already been stated the aiming angle depends on the altitude, air speed, and ground speed, the first two quantities being determined by auxiliary instruments. In the synchronizing sight the ground speed is automatically adjusted for by varying the speed of the motor.

MARK I-A BOMB SIGHT.

The Mark I-A bomb sight is modeled after the British Wimpeis high-altitude sight. It is an accurate sight at high altitudes and necessitates no stop watch or timing device. It corrects for height, speed of machine, and drift, and is adapted for all American bombing airplanes.

SECTION I.

SPECIAL AMMUNITION.

It is becoming the tendency more and more to eliminate the use of service ammunition in machine guns used for aircraft purposes. This is being supplanted by ammunition loaded with special bullets—armor-piercing, tracer, incendiary, armor-piercing-tracer, and armor-piercing-incendiary. Inasmuch as the pilots are now being protected by armor, it is necessary to resort to the use of special armor-piercing bullets.

ARMOR PIERCING.

Two types of armor-piercing bullets have been developed. One consists of a cupro-nickel jacket into which is inserted a hardened steel core weighing about 65 grains, covered with a lead casing, which is so formed as to permit a nose of lead to protrude from the cupro-nickel jacket. In the other type of bullet, the steel core is inserted in a copper jacket with a thin lining of lead between it and the core. This is known as the Bowers bullet.

TRACER.

In the base of the tracer bullet is inserted a cup of gilding metal, containing a mixture of barium peroxide and magnesium. This material is ignited upon the explosion of the cartridge and burns with a bright green flame which defines its path from the muzzle of the gun up to about 600 yards.

INCENDIARY.

The incendiary bullet consists of a flat-nosed cupro-nickel jacket, containing in its nose a charge of 8 grains of yellow phosphorus, held in place by a serrated plug of lead backed up by a base plug of lead. A small hole through the jacket, located near the junction of the serrated plug and the base plug, is filled with low-fusible alloy, which melts as the bullet passes through the rifle, and permits the phosphorus to ignite. This ammunition is practically the same as the British Buckingham ammunition. The flatnosed type of incendiary bullet is being replaced by the pointed nose of standard design.

ARMOR-PIERCING-INCENDIARY.

This bullet is a combination armor-piercing and incendiary bullet and consists of a cupro-nickel jacket into which is inserted a hardened steel core having a charge of yellow phosphorus at its base.

ARMOR-PIERCING-TRACER.

This bullet is a combination armor-piercing and tracer bullet, and consists of a cupro-nickel jacket into which is inserted a hardened steel core having a charge of barium peroxide and magnesium at its base.

INCENDIARY AMMUNITION.

Figure 49 shows the .30-caliber incendiary aircraft ammunition as compared with a .30-caliber service cartridge. It will be noted that the only difference in size is the flat-nose

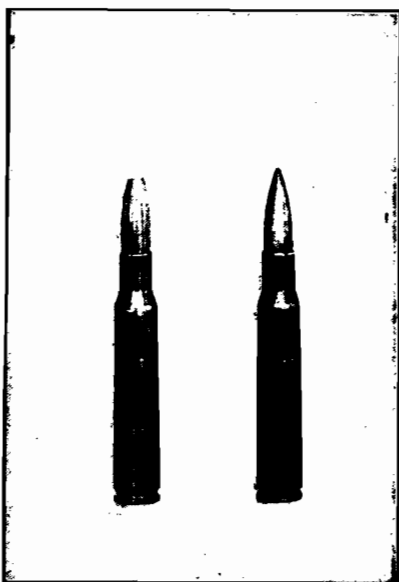


FIG. 49.—INCENDIARY AMMUNITION COMPARED WITH SERVICE AMMUNITION.

a bullet. The effect of this flat nose is to increase the destructive power of the projectile, since a much larger hole is formed than by the ordinary pointed projectile. As a result of this the incendiary effect is enhanced, as in the case of the projectile striking a gasoline tank there would be greater liability of igniting the gasoline than if only a small hole were formed. It is possible for a sharp-pointed incendiary bullet to pass completely through a tank of gasoline without igniting the contents.

STORAGE OF INCENDIARY AMMUNITION.

Incendiary ammunition should be stored in

a cool place where the temperature is not likely to exceed 80° F. and should be kept apart from all other combustible stores.

It is not liable to sudden deterioration, but the effect of sustained heat will probably cause a leakage of the phosphorus and an eventual ignition.

PACKING OF AMMUNITION.

Special ammunition for aircraft use is packed for shipment in wooden boxes 9½ by 18½ inches by 14½ inches deep, containing 75 paper boxes of 20 rounds each or a total of 1,500 rounds.

On the sides of the box is printed the kind of ammunition contained therein together with the words: "For aircraft use—No clips or bandoleers."

On each end is stamped a star within a circle.

A 4-inch yellow band is painted across the middle of the top, bottom, and sides and a 2-inch yellow band is painted across each end above the handhold recess.

A band of one or two colors is painted on each yellow band denoting the kind of ammunition. The colors are as follows:

Armor piercing.....	Blue.
Incendiary.....	Red.
Tracer.....	Green.
Armor-piercing-incendiary.....	Blue and red.
Armor-piercing-tracer.....	Blue and green.

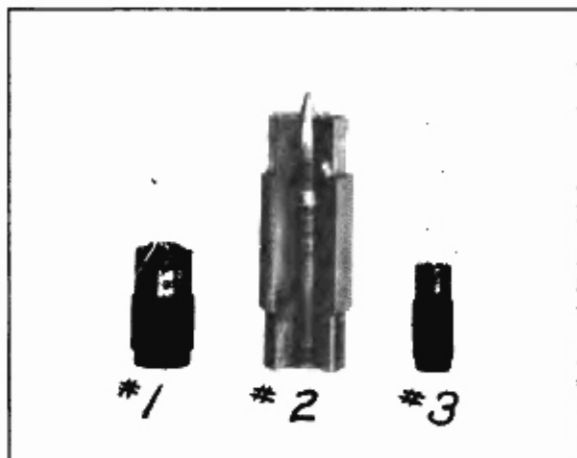


FIG. 50.—30-CALIBER CARTRIDGE GAUGE.

Each paper box is sealed with a yellow label on which is painted a colored band denoting the kind of ammunition.

CARTRIDGE GAUGES.

Cartridge gauges are furnished for gauging aircraft ammunition before loading it into the machine-gun belt or magazines. Every round should be gauged for over-all length and diameter, also depth of primer. Any rounds which do not check within the limits should be discarded since many machine-gun stoppages are due to defective ammunition.

The .30-caliber cartridge gauge consists of three separate gauges. (See Figure 50.)

Operation.—The cartridge is breeched in gauge No. 2 and the fit is examined. Gauge No. 1 is then pressed against the base of the cartridge, which checks the length and diameter. Gauge No. 3 is then applied to the base of the cartridge and checks the depth of the primer.

SECTION K.
PYROTECHNICS.

35 M/M PISTOL, AVIATION MARK I.

The 35 m/m, Aviation Mark I, pistol, firing a 35 m/m shell, is a single-barreled, single-action pistol, constructed



FIG. 51.—35 MM. PISTOL, AVIATION MARK-I.

of aluminum. It is used for signaling by means of colored lights—red, white, and green being the colors in general use.

ACTION.

To load, release the barrel catch by pressing in on the bottom underneath the frame, and tip the barrel up so as to open the breech. Insert a shell in the chamber and close the breech. To fire, draw the hammer to the rear as far as possible and release it. The pistol may now be discharged by pulling the trigger. When firing the pistol from an airplane

in the air, great care should be taken to aim so that the charge will not be blown back onto the tail, possibly setting fire to the machine. The pistol is held in the pilot's cockpit by means of two brass spring clips screwed to the side of the fuselage. The shells are held in a wooden rack.

These pistols have been used to good effect in setting fire to machines in case of forced landing in enemy country.

AIRPLANE FLARE, MARK I.

The airplane flare, Mark I, consists of a sheet-iron cylinder containing a charge of illuminating material attached to a large silk parachute. At the lower end of the cylinder is a quantity of black powder with a detonator sufficient to eject the illuminating charge and the parachute.

The flare weighs about 32 pounds and is suspended from



FIG. 52.—AIRPLANE FLARE, MARK I AND RELEASE MECHANISM.

the airplane horizontally in a light release mechanism operated by a Bowden wire.

OPERATION.

When the flare is released, the fan at the lower end is turned by the air and screws up into the flare. This detonates the black powder charge, which ignites the illuminating material and shoots it and the parachute clear of the cylinder. The parachute is carefully packed so as to insure its opening properly, and is of sufficient size to make the descent very gradual. There is enough illuminating material to burn with an intense light for approximately 10 minutes.

USE.

Airplane flares are used chiefly for illuminating targets for night bombing and artillery work and for dazzling the eyes of enemy antiaircraft and searchlight crews. They have

also been used successfully for lighting up landing fields for night landing. Experiments are being carried out relative to night photography from airplanes with the aid of these flares.

WING TIP FLARE, MARK I.

The wing tip flare, Mark I, is designed after the "Holt landing flare," which has been extensively used by the British and French since the beginning of practical night flying.

DESCRIPTION.

The Mark I wing tip flare consists of a cylinder about 4 inches long by $2\frac{1}{2}$ inches diameter, filled with a charge of magnesium illuminating material giving approximately 20,000 candlepower for 60 seconds. A little strontium nitrate imparts a reddish tinge to the light so as to make it an easier color for the eyes. The cylinder is held in a streamlined steel holder. Two brackets are generally carried, one fastened to the main spar underneath each lower plane about 3 feet from the end. Ignition is caused by an electric fuse operating on a circuit from the lighting generator or dry batteries, and controlled by a push button switch in the pilot's cockpit.

USE.

Wing tip flares are used for facilitating night landings in case of a forced landing or in conjunction with the ground lights when the latter are insufficient. One flare gives ample light to enable the pilot to accurately judge his distance from the ground and the second should be held in reserve. These flares should *never* be used if there is any fog or mist near the ground, as the light is strongly reflected by fog to such an extent as to dangerously dazzle the pilot's eyes. It is also advisable to blacken the under surface of the lower planes and the back of the propeller in order to minimize reflection.

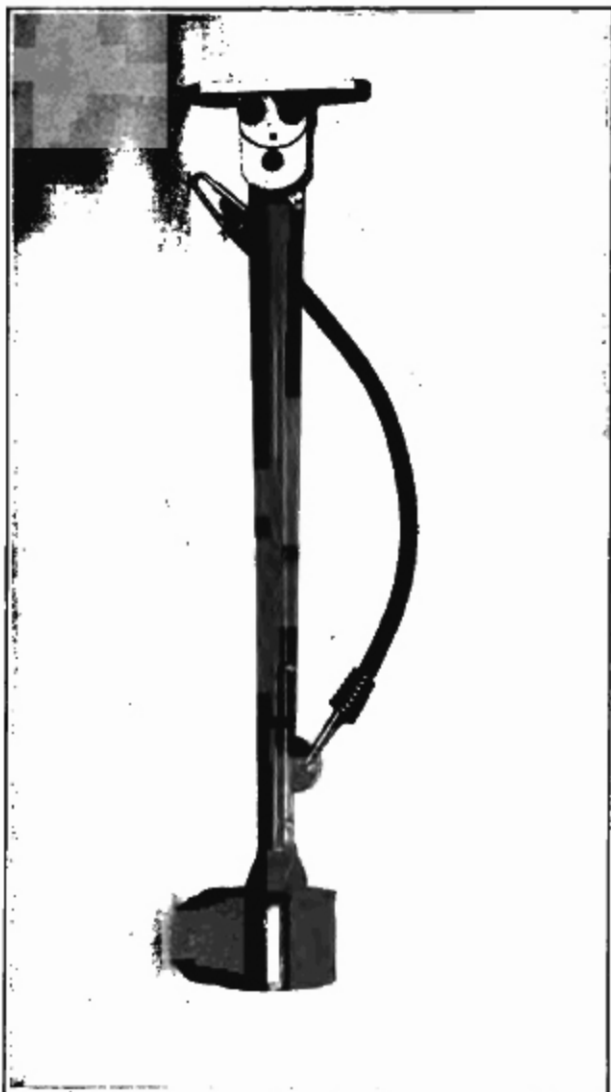


FIG. 52A.—MARK I WING TIP FLARE HOLDER.



FIG. 53.—MARK I WING TIP FLARE HOLDER, MOUNTED ON DE H 4.

SECTION L.

SMALL ARMS.

BROWNING MACHINE RIFLE.

DESCRIPTION.

The Browning machine rifle, model 1918, is a light automatic rifle chambered for United States standard .30 caliber ammunition. It weighs 15 pounds 8 ounces and has a rate of fire of approximately 500 shots per minute. It is a gas-operated gun and may be fired automatically or semi-automatically. The gun is fed from a magazine holding 20 or 40 rounds fitted underneath the receiver, just in front of the trigger guard. The automatic action of this gun is not disturbed by holding it in any position whatever. No tools are required for dismounting and assembling of the rifle unless it is desired to remove the barrel and gas cylinder, which necessitates the use of a special spanner provided in the kit. Ordnance handbook No. 1934 describes this rifle in detail.

USE.

This rifle may be carried as extra armament in case of emergency, or may be mounted on the flexible ring mount as a single or double flexible gun.

POINTS TO BE OBSERVED BEFORE A FLIGHT.

1. Thoroughly inspect the gun for defective or worn parts and replace all such parts with new ones.
2. Always carry gun in safety.
3. See that all magazines are fully loaded and in proper shape.
4. See that all working parts are covered with a thin film of oil.
5. See that gas cylinder has its proper setting.
6. See that recoil spring has not set so as to be too weak to operate the gun.
7. Be sure that magazine is *all* the way in and well fastened.

WINCHESTER RIFLE, CALIBER .351.

The Winchester self-loading rifle, caliber .351, is sometimes used as an auxiliary weapon in aircraft. The action of the gun is semi-automatic as the name implies, and it is fed from a detachable box magazine holding five cartridges. One cartridge may also be carried in the chamber, giving a total of six shots.

The magazine is removed by releasing the magazine catch which extends from the lower edge of the right-hand side of the receiver, and is then loaded and replaced in the gun.

The first cartridge is then fed into the chamber by pressing in on the rod extending from the forward end of the forearm. The gun will now fire every time the trigger is pulled until the magazine is empty.

The safety consists of a small pin located in the forward part of the trigger guard. The gun is safe when the safety extends out from the right-hand side of the guard, and is made ready to fire by pressing the safety to the left.

COLT AND SMITH & WESSON REVOLVERS, CALIBER .45.

The Colt and Smith & Wesson revolvers have been made to handle the .45 caliber automatic-pistol ammunition. They may be used either as single or double action guns and each holds six rounds. In order to facilitate loading and ejection the cartridges are held in spring tempered steel clips each containing three cartridges, thereby making it possible to load the gun with two clips of cartridges. The clips are expendable and are ejected holding the empty shells. A shoulder in each chamber prevents the cartridges from dropping through when placed in the gun without the clips. In case this is done, however, it will be necessary to pull the empty shell out of the chambers, since there is no rim for the ejector to force against.

It should be remembered that the cylinder on the Colt revolver rotates in a clockwise direction, and that on the Smith & Wesson in a counterclockwise direction.

INDEX.

	Page.
A.	
Aircraft ammunition.....	83
Aircraft ammunition, packing of.....	84
Airplane flare, Mark I.....	88
Armor-piercing ammunition.....	83
Incendiary.....	83
Tracer.....	84
Auxiliary sight.....	61
Ammunition, tracer.....	83
Ammunition, incendiary.....	83
Armorer's chest.....	14
Armorer's truck.....	15
B.	
Bombs.....	66
Bombs, marking of.....	73
Bombs, packing of.....	74
Bomb-release mechanisms.....	75
Bomb sighting, theory of.....	79
Bomb sight, Mark I-A.....	81
Bombs, storage of.....	74
Books, list of reference.....	7
Browning machine rifle.....	92
C.	
Cartridge gauges.....	85
C. C. interrupter gear.....	56
Colt revolver.....	93
Conversion tables.....	8
D.	
Disintegrating link belts.....	42
Double Lewis gun yoke.....	52
Dummy bomb, Mark I.....	73
E.	
Electric heater.....	
For Lewis machine gun.....	31
For Marlin machine gun.....	20
For Vickers machine gun.....	37
F.	
Fixed mounts.....	46
Flare, airplane, Mark I.....	88
Flare, wing tip, Mark I.....	89
Flexible mounts.....	47
Fragmentation bombs.....	69

UNIV. OF
ALABAMA

INDEX, 95

	Page.
G.	
Gauge, cartridge.....	85
Gauge, Lewis magazine.....	28
Gears, synchronizing.....	55
Gears, synchronizing mechanical.....	56
Guns, machine.....	10
Gun mounts.....	46

H.

Heaters, electric gun.....	20, 31, 37
High capacity drop-bombs.....	66
Hydraulic synchronizing gear.....	56

I.

Incendiary ammunition.....	83
Incendiary bombs.....	71
Interrupter gears.....	55

L.

Lewis aircraft machine gun.....	25
Lewis magazine racks.....	53
Lewis machine gun spares.....	31
List of reference books.....	7
List of bomb-release mechanisms.....	75
Loading handles, 30 Cal. Vickers.....	37

M.

Machine guns.....	10
Magazines, Lewis.....	27
Magazines, racks.....	53
Marlin aircraft machine gun.....	17
Marlin aircraft machine gun spares.....	22
Mechanisms, bomb release.....	75
Mechanical synchronizing gear.....	56
Metallic disintegrating link belts.....	42
Mounts:	
Fixed.....	46
Flexible.....	47
Machine gun.....	46
Sight.....	65

P.

Packing of aircraft ammunition.....	84
Packing of bombs.....	74
Pistol, 35 m/m aviation, Mark I.....	87
Post sights.....	61
Pyrotechnics.....	87

R.

Racks, Lewis magazine.....	53
Reference books, list of.....	7
Release mechanism, bomb.....	75
Release mechanism, list of.....	75