

For Official Use Only



HANDBOOK

FOR THE

4.2-INCH CHEMICAL MORTAR

Prepared under the direction of the
CHIEF OF CHEMICAL WARFARE SERVICE

1982



UNITED STATES
GOVERNMENT PRINTING OFFICE
WASHINGTON : 1982

TABLE OF CONTENTS

SECTION	Paragraph
I. General	1-2
II. General description and data.....	3-4
III. Detailed description.....	5-10
IV. Operating instructions.....	11-16
V. Care and maintenance.....	17-19
VI. Tools, accessories, and spare parts.....	20-28
VII. The hand cart.....	27-29
APPENDIX	Page
I. Range table.....	33
II. Charts, wind, and drift.....	34
III. Safety regulations.....	37

SECTION I

GENERAL

	Paragraph
Purpose and scope.....	1
References	2

1. **Purpose and scope.**—These regulations are published for the information and guidance of the Chemical Warfare Service and contain descriptive matter, illustrations, reference lists, and instructions necessary for the operation, care, and maintenance of the mortar and its ammunition, including safety precautions.

2. **Reference.**—Nomenclature of parts, lists of spare parts, and accessories for the 4.2-inch chemical mortar matériel are contained in Nomenclature and Price List of Chemical Warfare Matériel, July 1, 1932.

Appendix III, Safety Regulations for Range Firing, consists of extracts from Training Regulations No. 140-5 and Range Regulations for Firing Ammunition in Time of Peace which prescribes the general safety measures necessary in the firing of the 4.2-inch chemical mortar in time of peace.

SECTION II

GENERAL DESCRIPTION AND DATA

	Paragraph
General description.....	3
Miscellaneous data.....	4

3. **General description.**—*a.* The 4.2-inch chemical mortar is a rifled, muzzle-loading weapon designed for high-angle fire.

b. The mortar consists essentially of a barrel, bipod, and base plate. The barrel is demountable from the bipod and by the operation of a simple mechanical device can be detached from the base plate. Each of these component parts forms a separate load and is carried on the hand cart. (See figures 1 and 2.)

c. The breech end of the barrel is closed, and is fitted with a barrel base cap which carries a striker pin protruding into the barrel. The recoil of the mortar is transmitted to the



FIGURE 1.—The mortar installed without snubbers.



FIGURE 2.—7b² mortar ready to be fired

ground through the base plate against which the barrel base cap rests. The barrel is supported near the muzzle by a bipod fitted with elevating and traversing screws.

d. A sight is furnished for laying the mortar in direction and elevation. The range may be varied by changing either the elevation of the mortar or by varying the propellant charge, or by a combination of the two.

e. The mortar may be fired at a sustained rate of fire of 5 rounds per minute, and if emplaced in hard ground may be fired for a rapid burst of 20 rounds per minute.

f. The shell is filled with its authorized filling of either gas or smoke. It is fitted with a percussion fuze at the nose end and a cartridge case which carries the propellant charge at the base end.

g. The propellant charge consists of a 12-gage cartridge and hydroscopic powder in disk form. The cartridge is inserted into the cartridge container, the disk powder is placed on the outside of the cartridge container. They are fired by flames from the cartridge escaping through ports in the cartridge container. The charge is varied by varying the number of rings of disk powder. A ring consists of several disks of powder tied together.

h. When the shell is discharged from the mortar the fuze becomes armed. When the shell strikes a resisting object, such as the branch of a tree or the ground, explosion will result. Care should be taken when firing from woods to avoid striking branches of trees which might cause premature explosion of the shell near friendly troops.

i. More detailed information on the mortar and its ammunition is given in Section III.

4. Miscellaneous data.—a. The weights of the component parts are as follows:

	Lbs.	Oz.
Barrel	95	0
Base plate.....	100	0
Bipod.....	35	0
Shell filled, ready to fire.....	25	8
Shell filling.....	7	8
Fuze burster tube and charge.....	1	8

	Yards
b. Ranges.	
Minimum range at 1,066 mils elevation.....	600
Maximum range at 800 mils elevation.....	2,400

SECTION III

DETAILED DESCRIPTION

	Paragraph
Barrel.....	5
Bipod.....	6
Base plate.....	7
Shell.....	8
Fuse.....	9
Propellant.....	10

5. Barrel.—The barrel is a steel tube finished to careful inside dimensions and closed in at one end called the breech or base end. It is fitted near the muzzle with barrel clamps. The clamps are so designed that the barrel is free to rotate, but can not move longitudinally with reference to the clamp. On the underside of the front clamp is a threaded lug through which the traversing screw travels. The breech is closed by screwing thereon a base cap which is provided with a flat end striker pin. This striker pin protrudes into the barrel, and serves as an anvil upon which the striker contained in the striker nut on the base end of the cartridge container of the shell impinges and fires the primer of the ignition cartridge when the shell slides down in the barrel. The copper base-cap washer is placed in the base cap to insure a gas-tight joint between the base cap and barrel. The base cap has two pins projecting radially, which fit into slots in the base-plate cup and prevent rotation of the barrel. The barrel is rifled with 24 grooves and lands. The depth of the groove is 0.03 inch; the width of land is 0.0625 inch. The pitch is zero at the breech to 1 turn in 20 calibers. A muzzle cover of canvas or leather is placed over the muzzle end of the barrel to protect the interior surface from moisture. (See fig. 3.)

6. Bipod.—The bipod consists essentially of the following:

a. *Legs.* The legs consisting of two steel tubes fitted with feet and cross-stay lugs, are attached by means of male and female fork ends to the trunnion standard. They are held rigidly apart by the cross stay, which is hinged at its middle point but which locks in position as the hinge passes the dead center. The cross-stay end is tapped to take one end of the cross-stay tongue, so that any wear which may occur in the cross-stay bolts can be taken up at this point. (See fig. 4.)

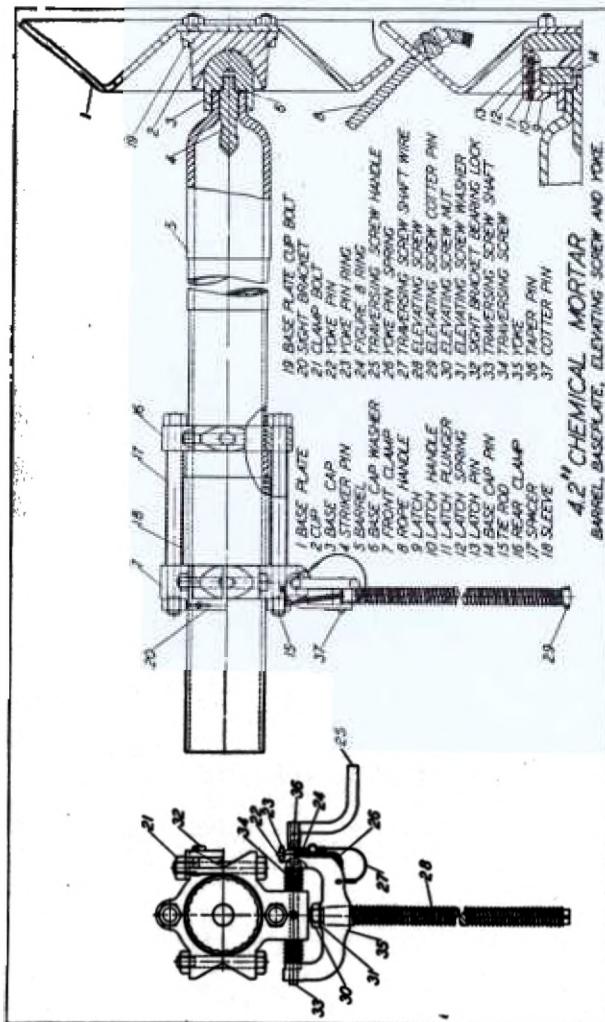

FIGURE 3

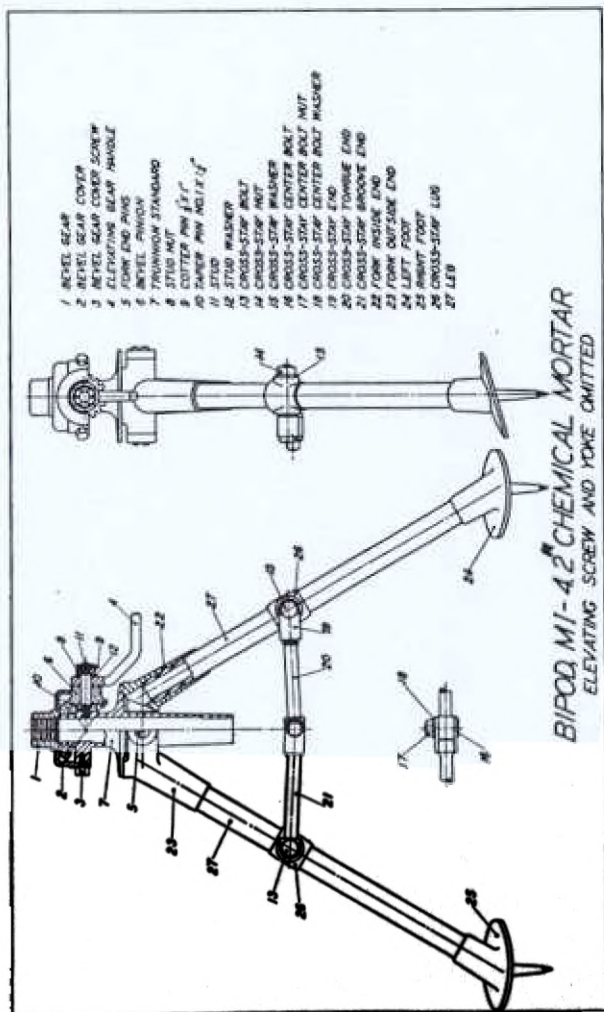

Figure 4

b. Trunnion standard. The trunnion standard forms the bipod head and also houses the elevating mechanism. (See fig. 4.)

c. Elevating mechanism. The trunnion standard is fitted with a bevel gear, threaded to receive the elevating screw, and a bevel pinion which turns on a stud. These gears are operated by an elevating gear handle. A counterclockwise movement of the handle elevates the screw. A bevel-gear cover, fastened to the trunnion standard by three cap screws, protects the elevating mechanism. The upper end of the elevating screw is fitted with a yoke which holds the traversing mechanism. (See figs. 3 and 4.)

d. Traversing mechanism. Holes in the arms of the yoke form bearings in which the traversing screw shaft revolves. The shaft supports and drives the hollow traversing screw by means of a dog clutch. The screw passes through and engages with threads in the lug of the barrel clamp. The screw is rotated by the traversing-screw shaft handle. The traversing-screw shaft, together with the clutch and traversing-screw handle form a bolt for locking the barrel and bipod together. This bolt is held in position by the traversing-screw-shaft locking pin, which in turn is held in its socket by a spring. The traversing mechanism limits are 40 mils right and 40 mils left. (See fig. 3.)

7. Base plate.—The base is made of alloy steel and has the form of a truncated pyramid 25 inches square at the base. A caststeel cup is bolted to the base plate. The cup is slotted to receive the pins on the base cap and steel latches are closed over the pins to prevent the barrel rotating on and rebounding from the base plate when the mortar is in action. (See figs. 1 and 3.)

8. Shell.—The 4.2-inch chemical mortar shell, M1 (fig. 5), when filled and completely assembled with fuze ready to fire, weighs about 25 pounds 8 ounces. Of this weight, about 7 pounds 6 ounces is the filling and 1 pound 8 ounces is the assembled fuze with burster tube and bursting charge. The shell body (2) is made from a steel forging, machined to final dimensions. To the inside wall of the shell is spot-welded a sheet steel vane which causes the liquid filling to rotate with the shell, and aids in stabilizing the shell in flight when fired from the mortar. The base of the shell is provided with a threaded stud to which the cartridge container (5) is secured. The

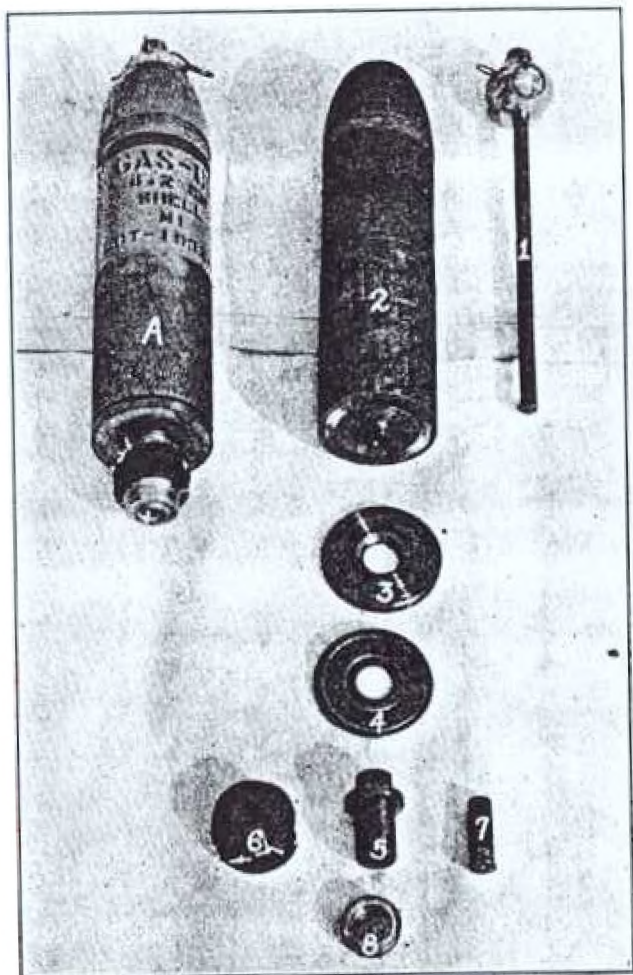

FIGURE 5.—4.2-inch chemical mortar shell

- A. Shell (complete)
1. Burster tube with fuse
2. Shell box.
3. Rotating disc
4. Pressure plate.
5. Cartridge container
6. Propellant disc
7. Ignition cartridge
8. Striker nut

cartridge container is made from either solid steel bar stock bored out and machined to dimensions, or from steel tubing. One end is threaded on the inside for attaching to the threaded stud on the base of the shell. The outside is threaded and contains twelve $\frac{1}{2}$ -inch radial holes drilled through the wall. Through these holes the flash from the ignition cartridge (7) is communicated to the propellant charge (6). In addition, the cartridge container is provided with one inner compression nut and one striker nut (8). The inner nut should be adjusted to apply a slight pressure on the propellant charge. The outer nut is called a striker nut, and is screwed on to the lower end of the cartridge container after the ignition cartridge and propellant charge is assembled. The striker nut holds the ignition cartridge rigidly in the cartridge container; it keeps the propellant from falling off the cartridge container and also provides a striker for the primer in the cartridge. In addition, it prevents the base of the ignition cartridge from being blown out into the base of the mortar when fired, and causes the flash of the ignition cartridge to spread through the radial holes of the cartridge container and ignite the propellant charge. The tapered, flat topped 4.75" firing pin is used. (See fig. 6.) In the past before the striker nut was developed an outer nut was issued. In firing a shell with the outer nut instead of the striker nut the *pointed* 4.75" striker pin must be used. (See fig. 7.) The nose of the shell MI is made from drawn steel and welded to the body of the shell. The nose has an adapter which is threaded to take the fuze and a finished cylindrical projection into which the central outside burster tube is pressed after the shell is filled, thus forming a gas-tight seal.

The rotation unit consists of two disks, one of brass called the rotating disk (3), and one of steel called the pressure plate (4). The brass member is held to the base of the shell and is approximately equal to the diameter of the shell. The pressure plate is smaller in diameter and fits into the brass disk. The pressure of the propellant gases expands the brass disk, forcing it into the rifling grooves of the barrel. (See fig. 5.)

9. Fuze.—a. The fuze is a bore-safe point-detonating fuze which weighs 1 pound 8 ounces; of this weight, 57 grams comprise the tetryl burster charge. The fuze has three safety features:

- (1) The setback pellet.

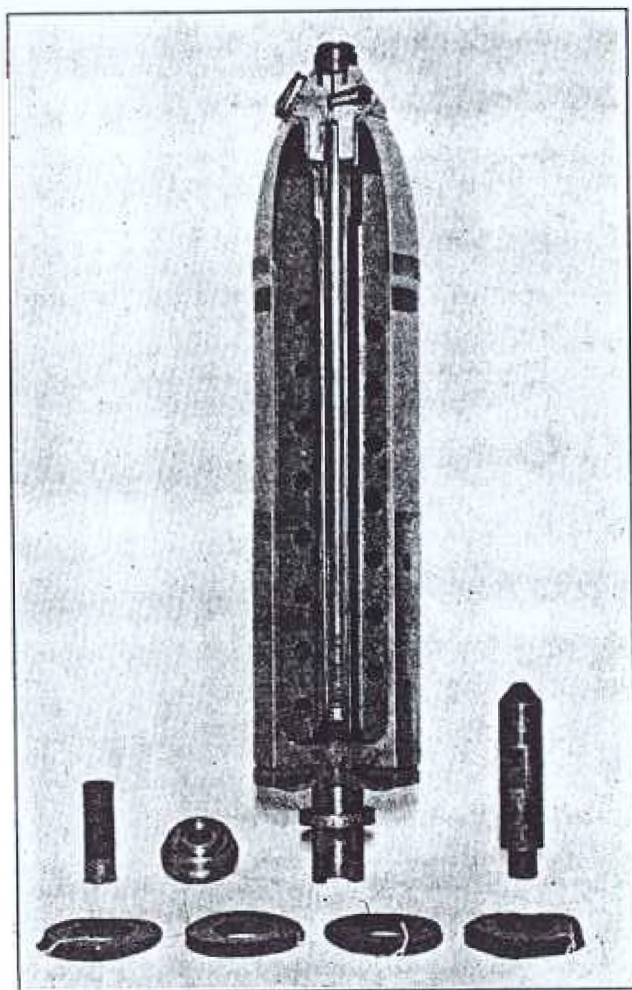

FIGURE 6.—When using the striker nut the tapered, flat topped 4.75" firing pin must be used.

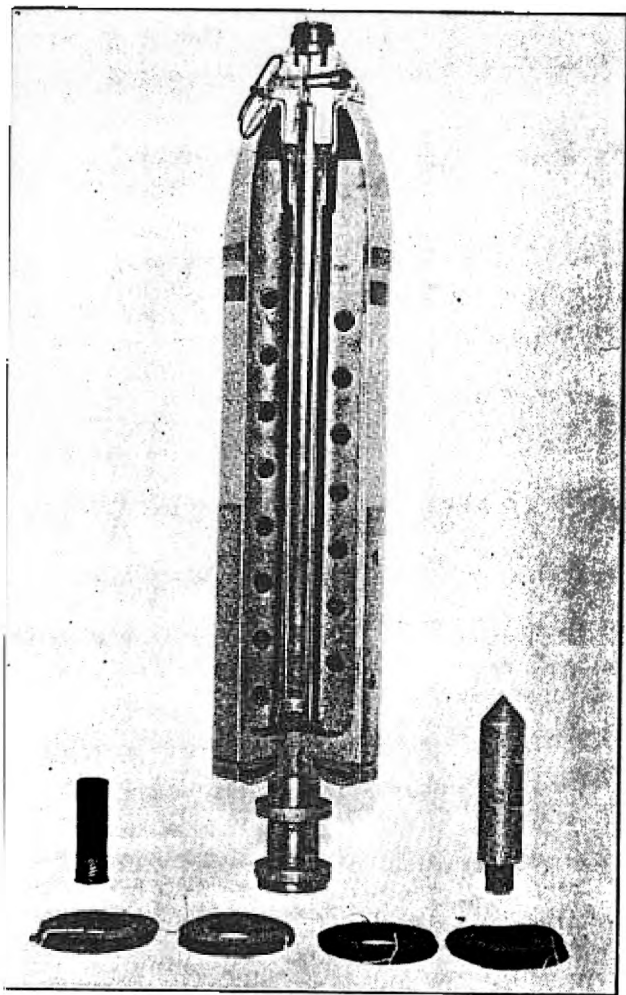

FIGURE 7.—When using the outer nut instead of the striker nut, the pointed 4.75" striker pin must be used

(2) The detonator container which can not arm until the fuze is fired from the mortar.

(3) The two brass spacers, held under the head of the firing pin, which prevent the firing pin from being forced down until the spacers are removed by centrifugal force after the shell is fired from the mortar. To prepare the fuze for firing, it is only necessary to remove the safety pin by pulling same from the fuze just before the shell is dropped down the mortar barrel.

b. The fuze is assembled to the shell and, after removing the safety pin, the shell is ready to fire. When the propellant is ignited, the pressure of the gases creates a setback force which causes the setback pellet to move down against the setback spring, thus releasing the combination detonator carrier and safety fork. At the same time, the setback force acts on the retaining ring, causing it to cut the shearwire, releasing the two brass spacers supporting the firing pin head and firing pin. Although the two brass spacers are released, they remain in position until setback ceases, after which centrifugal force causes them to fly free of the fuze. Centrifugal force also causes the detonator carrier to move in the direction of its projection from the fuze body. The detonator carrier, however, can not move over into armed position until the shell is clear of the gun, because the free end of the carrier is held back by the inner surface of the barrel. Once the fuze is clear of the muzzle, centrifugal force carries the detonator carrier out to the full armed position, where the detonator is in line with the firing pin and explosive train. In this position, centrifugal force also actuates the lock pin, causing it to move partly out of the detonator carrier into a hole provided in the body, thus locking the carrier in the armed position. After the spacers leave the fuze, the firing pin is supported by the shearwire which prevents air pressure forcing the firing pin against the detonator while the shell is in flight. On impact with the ground or other obstacle, the firing pin is driven down, shearing the wire and setting off the detonator which detonates the tetryl and so bursts the shell. (See fig. 5.)

10. Propellant.—One full charge of propellant MI consists of 1,200 grains nonhygroscopic powder, in perforated disk form, made up of eight 150-grain rings, and one ignition cartridge, which is a standard 12-gage shotgun cartridge, loaded with 90



FIGURE 8.—Installation, showing plank subbase and four sandbags filled with sand to act as buffer between planks and steel baseplate. This installation is necessary to keep baseplate from digging further into ground when firing in muddy, loose, or sandy soil.

grains of Special Infallible powder. Each ring of the propellant is provided with a central hole to permit its assembly around the cartridge container. To assemble a propellant charge around the cartridge container, first screw the upper nut up against the pressure plate, then assemble the requisite number of rings of propellant around the cartridge container. Insert the ignition cartridge into the cartridge container, and then screw the striker nut tightly to the lower end of the cartridge container. Adjust the upper nut with the hand to apply a slight pressure to the rings of propellant. The number of rings of propellant are varied according to the ranges desired. (See fig 5 and Appendix I.)

SECTION IV

OPERATING INSTRUCTIONS

	Paragraph
Preparation of position.....	11
Laying of mortar.....	12
Loading and firing.....	13
Misfires.....	14
Safety precautions.....	15
Disassembly and assembly.....	16

11. Preparation of position.—An excavation should be made and the base plate installed so that it is perpendicular to the line of fire and inclined to the horizontal at an angle which is a complement of the angle of elevation of the barrel. In order to add stability in soft ground, four sand bags filled with dry sand or hard dry earth, and flattened to 3 inches in thickness, should be placed under the base plate. When the ground is very wet or soft, three 2-inch boards should be placed under sand bags. (See fig. 7.) These boards may be carried on ammunition carts. The excavation should be deep enough so that when barrel and bipod are in firing position, the bipod feet will be firmly on the ground with the following precautions observed: a. Barrel normal to base plate; b. plane of bipod normal to barrel; c. not more than 6 inches of elevating screw visible above the level gear. The lower end of the barrel is placed in the depression of the base plate cup and the steel latches clamped over the radial pins of the barrel base cap. With the barrel held in a position approximating the desired setting of the mortar, the bipod is placed in position and locked to the barrel. The foot of the bipod should be planted firmly in the ground, with

the legs as nearly as possible at right angles to the barrel. A line from the center of the base plate in the direction of fire should pass midway between the feet of the bipod. Sand bags are placed upon each foot of the bipod to overcome any tendency of the mortar to lift up the foot of the bipod during action. Sand bags are also placed on the base plate around the base of the barrel to aid in stabilizing the mortar, one bag wedged between barrel and ground. (See fig. 2.)

12. *Laying of mortar.*—The lower end of the barrel is placed in the indentation of the base plate which gives the barrel its general direction. The sight, being set for the desired direction and elevation, indicates when the barrel has its proper direction and elevation. Minor changes in direction are secured by means of the traversing screw, and, in elevation, by means of the elevating screw. With the sight set for the desired elevation and direction, and both bubbles centered, the initial laying of the mortar on the target is considered completed. If during action the mortar shifts from its original position, it can be restored by recentering both bubbles, and again placing the line of sighting on the target or aiming stake, depending upon whether direct or indirect laying is being used. This must be done between rounds or during intervals of rapid fire, as the sight can not be safely operated during periods of actual firing.

13. *Loading and firing.*—*a.* The shells are packed in boxes containing two complete rounds including fuze. In each box there is a sealed container in which are packed two complete propellant charges, each charge consisting of one No. 12-gage cartridge and 16 rings of disk powder. One of the rings in each container is divided into two equal parts. The full rings are tied together with white silk thread, the divided rings are tied with red silk thread. This allows one cartridge and eight rings of powder for each shell. Thus packed, the boxes are delivered to the mortar.

b. Loading.—For purpose of safety, as well as economy of effort, the preparation of ammunition should be conducted under competent supervision in an orderly sequence of operations which should be strictly adhered to, as follows:

- (1) Open boxes and propellant containers.
- (2) Remove striker nut from cartridge container. Clean the shell by removing all rust-prevention compound and dirt from guides, body, cartridge container, and flash-outlet holes. Remove rust or paint from guides by means of emery cloth.

(3) Examine guides for burrs which would cause the shell to stick in the barrel. Burrs should be filed or hammered down.

(4) Place the necessary number of rings of disk propellant on the cartridge container. (See Appendix I.)

(5) Insert cartridge in cartridge container, taking care that base flange of cartridge is firmly seated against the cartridge container.

(6) Replace the striker nut on the cartridge container. Unused powder disk rings will be salvaged for future use.

(7) When necessary, the safety pin in the fuze may be straightened with a pair of pliers, to facilitate rapid removal by the gun squad.

c. Firing.—(1) *Immediately before firing, and at no other time, remove safety pin from fuze.*

(2) To fire the mortar, drop the assembled round into the muzzle of the mortar, fuze end up.

(3) Remove hand quickly from muzzle of the mortar after dropping the shell.

d. As the round nears the bottom of the barrel, the striker pin strikes the striker contained in the striker nut on the end of the cartridge container of the shell and fires the primer of the ignition cartridge. The flames of the cartridge pass through the holes in the cartridge container and ignite the disk propellant. The shell, carrying the cartridge case with it, is projected from the barrel and the mortar is ready for another shell.

14. Misfires.—*a.* A misfire is the failure of a properly assembled round to leave the mortar after release into the barrel. Misfires may be due to any of the following causes:

(1) Defective primer or cartridge.

(2) Wet primer, cartridge, or propellant.

(3) Propellant rings falling off into the barrel, parts of clips or striker-nut assemblies, or other débris covering the point of the striker pin.

(4) Loose, bent, or defective firing pin, or cartridge container.

(5) Burrs, rust, paint, or dirt on guides, or dirty bore, preventing the shell from reaching the striker, or reaching it with sufficient force to penetrate primer.

(6) Striker-nut assembly not screwed down tight against primer.

(7) Use of improper firing pin. (See par. 8 and figs. 6 and 7.)

b. (1) In case of a misfire, the gunner (No. 2) is required to call out "Misfire." All personnel remain at side or in rear of the mortar for at least one minute. After one minute, the mortar corporal commands "Remove shell." The breech end of the barrel is raised and tilted so that the misfired shell will slide out easily into the hands of the firer (No. 1). The safety pin is immediately replaced and the defect corrected, the round being placed on the gun dump. Firing is resumed on command when the mortar has been relaid and checked.

(2) As the fuze is not armed until the shell leaves the muzzle after positive discharge, a misfire normally presents no hazard to the safety of the gun crew, unless a heated barrel or sparks should ignite the disk powder during unloading.

15. **Safety precautions.**—For safe and proper operation of the mortar, the following precautions should be observed at all times:

a. Be sure to remove the hand quickly from the muzzle of the mortar after dropping the shell.

b. Always see that the upper and lower guides (head and base) of the shell are clean.

c. Be sure that the cartridge end of the shell is pointed downward when firing and that the shell is dropped into the mortar cartridge end first.

d. See that the cartridge fits closely in cartridge container.

e. Before firing make sure that all oil is removed from the bore of the mortar. If the bore is oily, smoke will be given off and the position disclosed.

f. The position of the mortar should be checked after the first round, as the initial round always tends to seat the base plate in the ground, thus causing a change from the original position of the mortar.

g. See Appendix III, Safety Precautions for Range Firing.

16. **Disassembly and assembly.**—In assembling and disassembling the mortar, no other tools than those issued with the outfit should be used.

a. *To dismount barrel from bipod.*—(1) Lift out the traversing-screw shaft locking pin.

(2) Withdraw the traversing-screw shaft assembly which locks the barrel and bipod together.

(3) Lift out the barrel.

(4) Replace the bolt and traversing-screw shaft locking pin.

b. *To replace the barrel on bipod.*—Lift out the traversing-screw shaft locking pin, withdraw the traversing-screw shaft assembly, and proceed in the reversed order to that outlined in *a* above.

c. *To remove base cap.*—Use special wrench provided for this purpose, applying the wrench to the radial pins on base cap. Light blows on the handle of the wrench may be necessary to start the threads.

d. *To replace base cap.*—Use special wrench for replacing base cap. Care should be taken to insure a tight fit between the base cap and barrel to avoid gas leaks.

e. *To remove striker pin.*—Remove base cap from barrel and apply combination wrench to flat milled section of the striker pin. The base cap may be held against rotation during the operation by means of the base-cap wrench.

f. *To replace the striker pin.*—Proceed in reverse order to that described above. Put a drop of oil on the threads before screwing the striker pin firmly into the base cap.

g. The personnel will have no difficulty in dismantling parts of the remaining mechanism. Care should be taken in dismantling bolts, etc., not to batter them by driving them out with a hammer. A piece of hardwood or a copper drift should be interposed.

SECTION V

CARE AND MAINTENANCE

	Paragraph
General care-----	17
Cleaning before and after firing-----	18
Painting-----	19

17. *General care.*—a. The bore of the barrel and all unpainted surfaces should be kept clean and free from rust. The bore should always be kept slightly oiled with a light oil when not in actual use and the muzzle covered with the muzzle cover. The use of the muzzle cover is especially important in rainy weather, as water, in addition to causing rust, seriously affects the range of the mortar. The muzzle cover should be held in place by means of its cord.

b. If the mortar is to remain unused for some time, all bright and unpainted parts, such as the bore, striker pin, screws, gears, threads, etc., after being first thoroughly cleaned, should be protected by a light coat of rust-preventing compound as issued. The rust-preventing compound is easily removed by the use of burlap or waste dipped in gasoline.

c. The striker pin should be examined from time to time and if found so worn, bent, or defective as to cause misfires, it should be replaced, care being taken that the new striker pin is tightly screwed into the base cap.

d. Examine and tighten the nuts and screws occasionally.

18. **Cleaning before and after firing.**—It is important that proper attention be given to the cleaning and inspection of the mortar before, during, and after firing.

a. *Before firing.*—(1) Remove all oil from the bore. Also remove any excess oil on the outside of the barrel and the bipod.

(2) See that the striker pin is firmly screwed home in the base cap and that the base cap is tightly screwed on to the barrel, insuring a gas-tight fit. Use the base-cap wrench for tightening the base cap.

(3) See that all nuts, bolts, and screws are in position and securely tightened.

b. *During firing.*—(1) The barrel should be swabbed out after every five rounds, except when firing rapid bursts.

(2) The base cap and firing pin should be examined at every opportunity and cleaned and tightened.

c. *After firing.*—(1) Unscrew the base cap and clean and sponge out the barrel, removing all residue. Lightly oil the bore.

(2) Clean the striker pin and then oil lightly.

(3) Clean the base cap and oil.

(4) Examine, clean, and oil all working parts of the bipod.

(5) Clean the base plate.

(6) Tighten all nuts and screws.

19. **Painting.**—a. All parts of the matériel, with the exception of the bore and bearing surfaces, should be kept well painted as a protection against rust. Clean and wash the matériel thoroughly to remove all dirt and grease and allow to dry before applying the paint.

b. The following parts will be painted in accordance with instructions on drawings and specifications:

(1) The barrel, complete, with sleeve and clamps, except traversing screw and bore.

(2) The bipod, except the gear teeth, elevating screw, and bearing surfaces.

(3) The base plate.

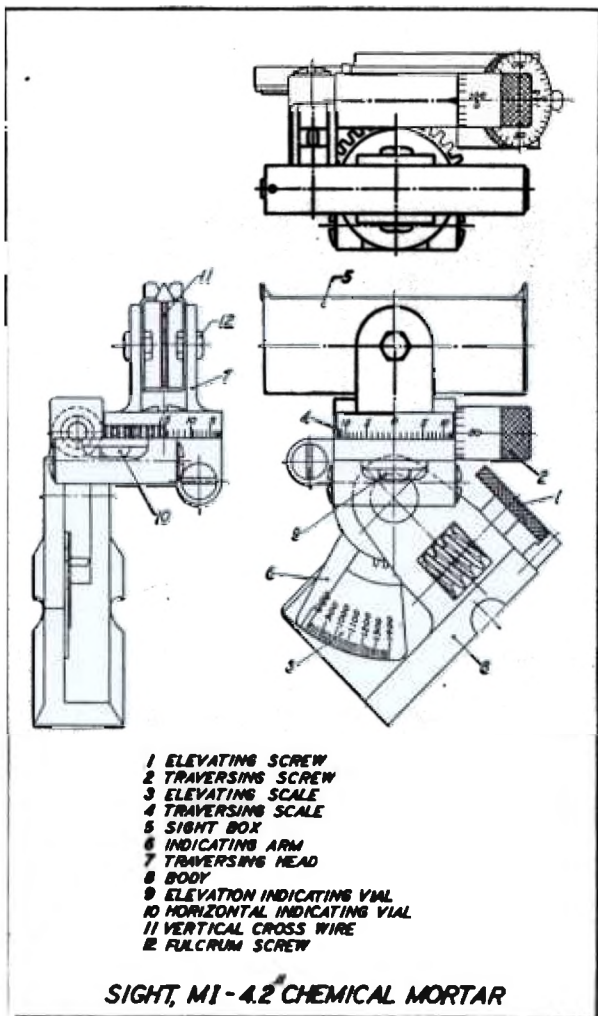

FIGURE 9

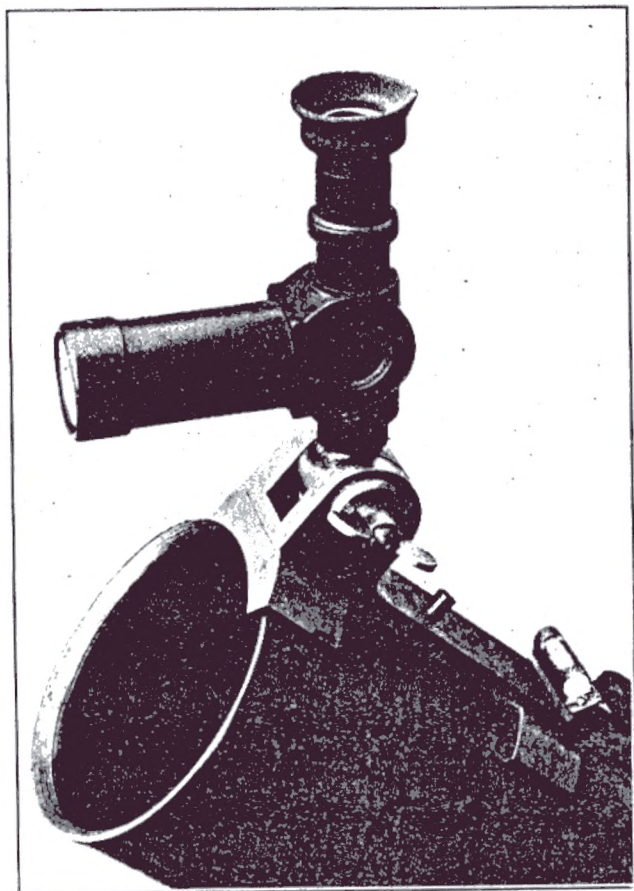

FIGURE 10.—Goniometer sight

SECTION VI

TOOLS, ACCESSORIES, AND SPARE PARTS

	Paragraph
General.....	20
Sight, Mark I.....	21
Sight goniometer.....	22
Clinometer.....	23
Practice shell.....	24
Chest, packing, chemical mortar.....	25
Accessories and spare parts.....	26

20. **General.**—Only the tools issued with the mortar will be used in making repairs and adjustments, and they must not be used for any other purpose. When not in use, they should be stored in their proper place in the receptacle provided for them.

21. **Sight, Mark I.**—*a. Description.*—The Mark I sight consists essentially of three major parts, viz, body, traversing head, and sight box. It is used to indicate the elevation on initial set-up and between rounds during action. On the body is mounted the traversing head with sighting tube or box. The traversing head is designed so that it can be rotated both horizontally and vertically. The degree of movement is indicated by scales graduated in mils. Two level bubbles indicate the position of the barrel with reference to the horizontal plane. The sighting tube, mounted on the traversing head, carries an open sight as well as the vertical wire and slit-type sight. The sighting tube is held by two fulcrum screws which allow the sighting tube to swing in a vertical plane without disturbing the traversing-head setting. (See fig. 1.)

b. Assembly and operation.—Remove the sight from the case in which it is carried and place the beveled extension of the base into the groove of the sight bracket located on the left-hand side of the front barrel clamp. Push the base of the sight firmly down into the bracket until the key-way slot in the sight base lines up with the lock pin in the bracket. In this position, lock the sight base in place by turning the lock lever on the side of the sight bracket one-half turn. Care should be taken when attaching the sight to the bracket that the sighting tube or box is correctly assembled. The open sight, made a part of the upper surface of the sighting tube, is a simple indication as to whether the tube is properly assembled. (See fig. 2.)

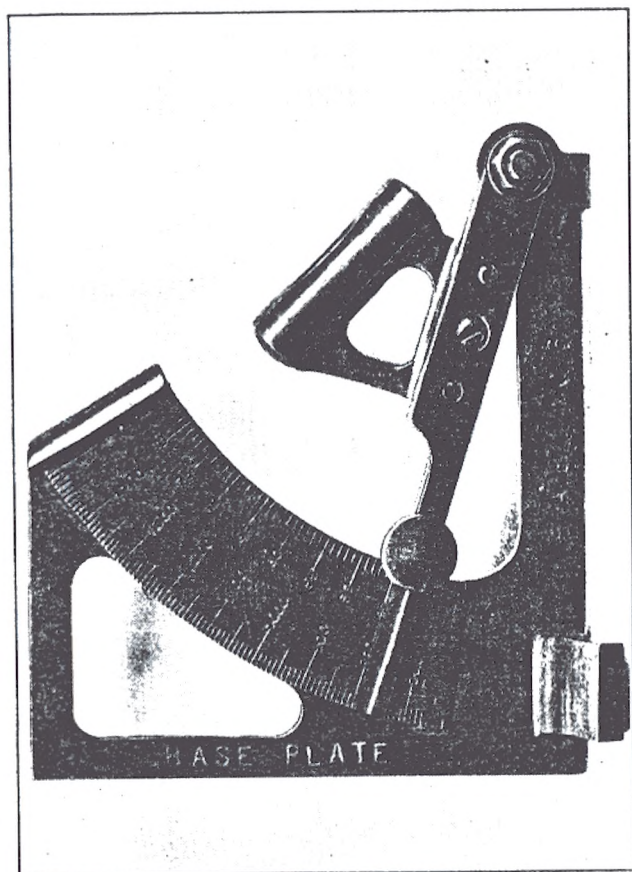

-Clinometer

The sight being attached to the sight bracket as explained above, the operation of the sight in laying the mortar is as follows:

(1) Set the indicator on the elevation scale at the desired elevation.

(2) Elevate or depress the barrel by means of the elevating screw until the level bubble, located on the left hand side of the sight, is centered.

(3) Tamp the feet of the bipod as may be necessary until the level bubble located at the front of the sight is centered. When this bubble is centered, the barrel is leveled laterally and has no cant.

(4) In laying for direction, either the open sight or the box sight may be used. With the upper thumb screw traverse the sighting tube until the indicator of the deflection scale is set at the desired deflection. With the desired deflection set on the sight, the mortar is traversed until the line of sighting is either directed on the target or the aiming stake, depending upon whether direct or indirect laying is to be used.

22. Sight, goniometer.—a. Description.—The goniometer sight has been issued in the past to certain organizations and is now obsolescent. This sight is a compact right-angle telescope containing cross hairs and a mil scale. It is mounted on a base which fits the upper edge of the muzzle of the mortar when in the firing position. A cross bubble is provided to set the sight in the vertical plane of the axis of the bore.

b. Operation.—The upper edge or lip of the base of the sight is placed on the upper edge of the muzzle, the cross bubble centered, and the desired direction obtained by traversing the mortar, as indicated by the mil scale of the sight. (See fig. 10.)

23. Clinometer.—a. Description.—The clinometer is used to indicate the elevation of the mortar and to facilitate the operation of emplacing the mortar base plate so that the plane of its surface may be set normal to the axis of the barrel. Its action depends upon the leveling of a level glass carried on a movable arm which can be set at the desired elevation.

The movable arm is made up of three principal parts: 2 arms, right and left, and a level-glass holder. It pivots about a pin fixed in the base of the clinometer and can be clamped in the position desired by the thumb screw.

The level-glass holder contains the level glass, held in place by two button-head screw plugs. Two scales, right and left,

graduated in mills, one on each side of the clinometer, are fastened to the body by screws. (See fig. 11.)

b. Operation.—Move the level-glass arm until it coincides with the desired elevation, as indicated by the elevation scale. The arm should then be fixed in this position by tightening the thumb screw. To indicate elevation, the clinometer is held on the upper side of the barrel in a vertical position. It only remains to elevate or depress the mortar, as the case may require, until the level-glass bubble indicates that a level position has been reached, when the barrel will have the desired elevation.

During the operation of emplacing the base plate, if the angle of elevation to be used by the mortar is known, the clinometer with its base-plate edge is used to set the base plate normal to the proposed line of fire. The desired angle of elevation is set on the clinometer, the base-plate edge of the clinometer is held against the base plate, and the latter is moved until the clinometer level-glass bubble is centered. Thus, the barrel when laid with the desired elevation will be normal to the plane of its base plate.

24. Practice shell.—A practice shell is being developed and its description and instruction for use will be furnished when shell is ready for issue.

25. Chest, packing, chemical mortar.—The chemical-mortar packing chest in a strongly braced wooden box fitted with a hinged lid secured with metal hasps and a padlock. The inside of the chest is provided with partitions and cross members for holding the various mortar components, accessories, and spare parts. The chest has four rope handles to facilitate handling. It is approximately 55 inches long by 18 inches wide by 13½ inches high; has a displacement of 7.7 cubic feet; and weighs, when packed, approximately 263 pounds. The chest is used only for the shipment and storage of the mortar parts, accessories and spare parts. When in actual use the mortar, with various accessories and spare parts are carried on the hand cart.

26. Accessories and spare parts.—The accessories and spare parts for the 4.2-inch chemical mortar are as follows (number to the right of each article identifies article in fig. 12) :

- 12 bags, sand, olive drab, duck (3).
- 1 chest, packing (5).
- 1 clinometer with case. (See fig. 11.)

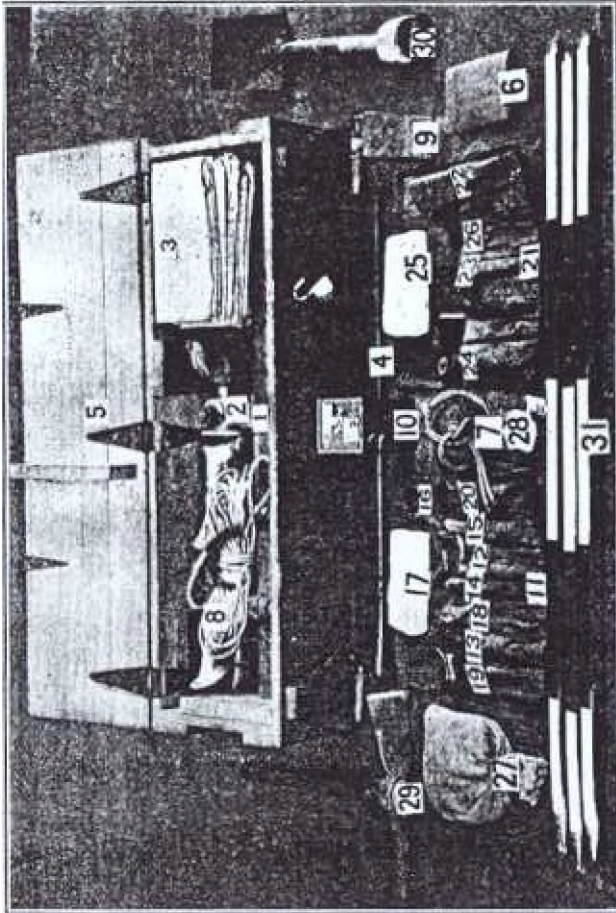

FIGURE 12.—Chest and accessories

- 6 cloth, emery, No. 00, sheets (6).¹
- 1 cover, muzzle (7).
- 1 lanyard, complete (8).
- 1 can, oil, engine (medium grade), quart (9).
- 1 pick, mattock (29).
- 1 rod, cleaning (with claw) (4).
- 1 roll, tool, gunner, complete, consisting of:
 - 1 roll, empty (11).
 - 1 handle, traversing-screw, complete with locking pin (12).
 - 1 oiler, one-fourth pint (13).
 - 1 pin, striker (14).
 - 1 screw, traversing (15).
 - 1 washer, copper, for base cap (16).¹
 - One-half pound waste (17).¹
 - 1 pliers, combination, 8-inch (18).
 - 1 wrench, base cap (19).
 - 2 wrenches, combination (20).

4.2-INCH CHEMICAL MORTAR

- 1 roll, tool, ammunition, complete, consisting of:
 - 1 roll, empty (21).
 - 6 cloth, emery, No. 00, sheets (22).
 - 2 files, flat, mill, 8-inch (23).
 - 1 hatchet (24).
 - One-half pound waste (25).¹
 - 1 wrench, fuse (26).
- 1 sight, chemical mortar, MI, complete (10).²
- 1 spade (30).
- 3 stakes, aiming, 1¼ by 1¼ inches by 5 feet (31).
- 1 waste, bag, 1 pound (27).¹
- Spare parts, consisting of:
 - 1 nut, hexagonal, semifinish, standard, ⅝-inch, 16-NC-2, for cross-stay center bolt.¹
 - 1 nut, hexagonal, castellated, special, ⅝-inch, 18-NC-2, for bevel-pinion stud.¹
 - 1 nut, hexagonal, jam, standard, ⅝-inch, 18-NC-2, cross-stay bolt.¹
 - 1 nut, hexagonal, special, ⅝-inch, 10-NC-2, for tie rod.¹
 - 1 nut, hexagonal, special, ⅝-inch, 14-NF-2, for bipod elevating screw.¹
 - 1 nut, hexagonal, special, ⅝-inch, 10-NC-2, for tie rod.¹
 - 2 pin, cotter, one-eighth by 1 inch.¹
 - 2 pin, cotter, three-sixteenths by 1½-inch.¹
 - 2 pin, cotter, three-sixteenths by 2 inch.¹
 - 1 pin, taper, No. 1, 1¼ inches long.¹
 - 1 pin, taper, No. 2, 1 inch long.¹
 - 1 pin yoke.¹
 - 1 screw, cap, special, ⅜-inch, 18-NC-2 by five-eighths-inch long, for bevel gear cover.¹
 - 1 washer, copper, for base cap.¹

¹ Expendable.² Sight, chemical mortar, MI, complete, is no longer a part of the accessories and spare parts. In the future this item will be listed separately as a part of the mortar.

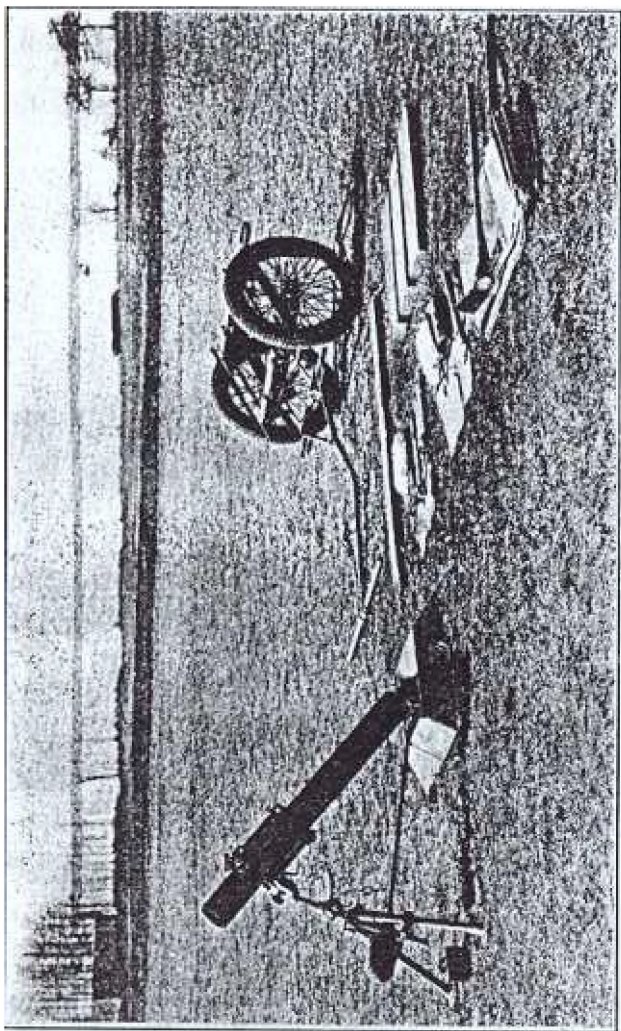

FIGURE 13.—Mortar and cart

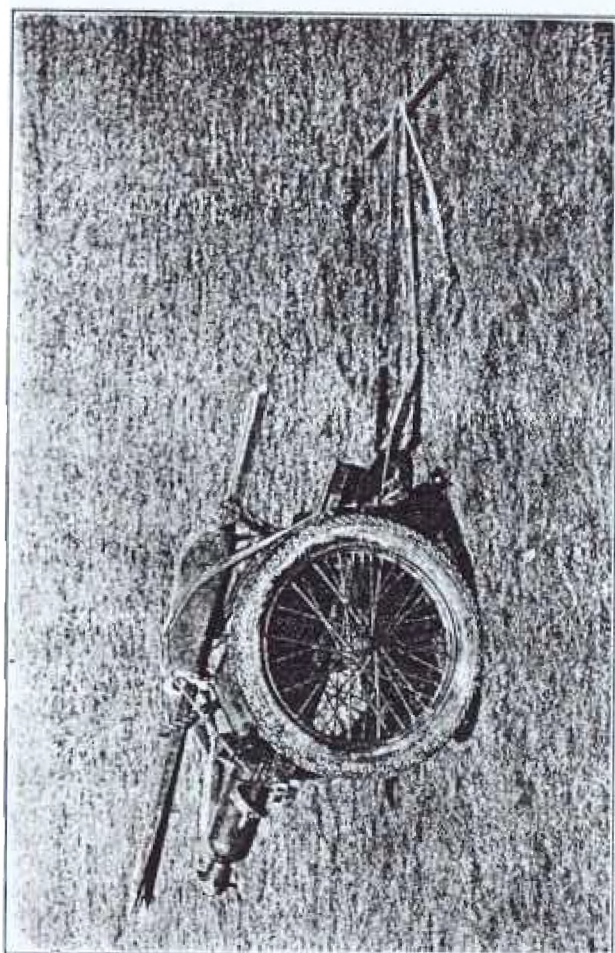

FIGURE 14.—Mortar loaded on cart

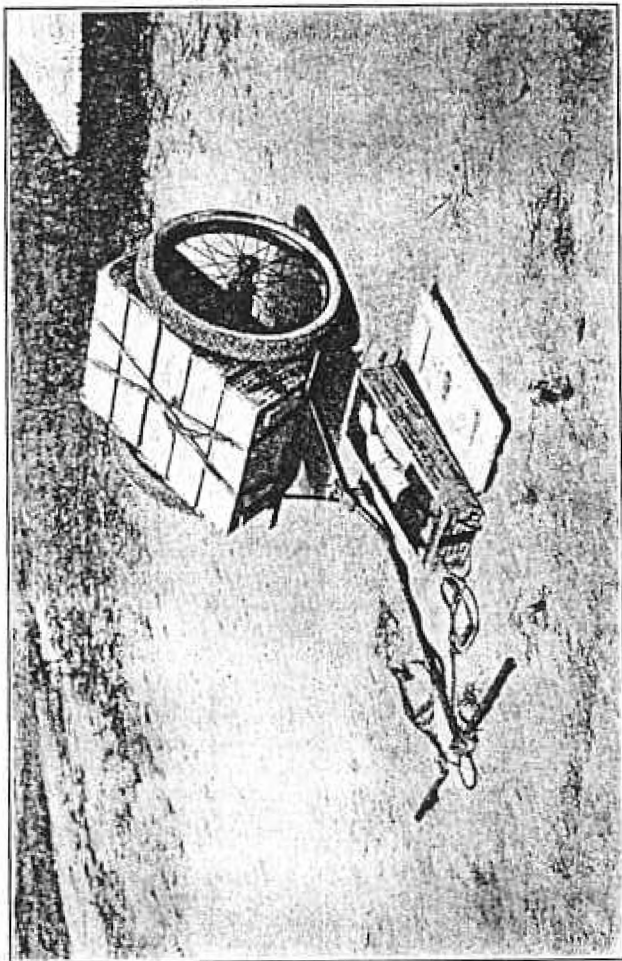

FIGURE 15.—Cart loaded with ammunition

SECTION VII

THE HAND CART

	Paragraph
Mortar cart.....	27
Ammunition cart.....	28
Data.....	29

27. **Mortar cart.**—The 4.2-inch chemical mortar and its accessories and ammunition are transported by means of 2-wheeled man-drawn carts. The carts are constructed of steel and fitted with wire wheels and pneumatic tires, 27 inches in diameter. A detachable draw bar is provided for pulling the carts, and handles are attached to the frame for use in lifting the carts onto motor trucks, transport wagons, or other vehicles. The overall length of the cart, including the drawbar, is 6 feet 9½ inches. The tread of the cart is 31½ inches; the inside width of frame is 25½ inches; the inside length of frame is 32½ inches. In transporting the mortar with its accessories, two metal frames are used. These frames fit inside the cart-frame proper and are known as the barrel frame and base-plate frame. To pack the mortar on the cart, the barrel frame is placed in position on the cart-frame proper. The mortar barrel, bipod, pick, and spade are then placed on the barrel frame and fitted into the indentations or projections provided in the frame for carrying each item. The base-plate frame is then placed in the barrel frame. The base plate is then fitted into its frame and the whole load is made secure by means of straps passing diagonally across the cart. (See figs. 13 and 14.)

28. **Ammunition cart.**—The carts are so designed that they may be used interchangeably for carrying either the mortar with its accessories or the ammunition. The dimensions of the inside of the frame are such that five shell boxes may be carried, thus allowing 10 rounds of ammunition for each cart. The shell boxes are carried with sides resting on the frames and are held in place by means of straps running diagonally across the cart. (See fig. 15.)

29. **Data.**—The weights of the carts and their loads are as follows:

	Pounds
Cart (less frames).....	85
Barrel frame.....	20
Barrel.....	95
Base-plate frame.....	20
Base plate.....	100

	Pounds
Bipod	35
Accessories and spare parts (carried on cart)	60
Total, mortar cart, loaded	425
Cart (less frames)	95
Ammunition (5 boxes complete)	325
Total, ammunition cart, loaded	420

For other weights see paragraph 4.

APPENDIX I
RANGE TABLE FOR 4.2-INCH CHEMICAL MORTAR
 MILS ELEVATION

Range yards	2 rings	2 1/4 rings	3 rings	4 rings	5 rings	6 rings	7 rings
600	1,060						
650	978						
700	844	1,048					
750		978					
800		908	1,066				
850		820	966				
900			934				
950			872				
1,000			800				
1,050				1,040			
1,100				965			
1,150				951			
1,200				907			
1,250				853			
1,300				800	1,066		
1,350					1,022		
1,400					978		
1,450					933		
1,500					890		
1,550						844	
1,600				1,048			
1,650				1,013			
1,700				978			
1,750				933			
1,800					1,040		
1,850					1,013		
1,900					978		
1,950					933		
2,000						1,040	
2,050						990	
2,100						944	
2,150						900	
2,200							1,040
2,250							1,013
2,300							978
2,350							943
2,400							907
2,450							872
2,500							836
							800

NOTE.—One bundle or ring contains 150 grains of disk propellant. The cartridge, a standard 12 gage shotgun cartridge, is loaded with 60 grains of special infallible powder. (See par. 10.)

APPENDIX II

CHARTS FOR DRIFT AND WIND CORRECTIONS

TABLE I.—Drift table

	Drift is to the right
	<i>Mils</i>
400	5
800	10
1,200	15
1,600	20
2,000	25
2,400	30

There is always a deviation to the right caused by the drift of the projectile. In order to counteract the effect of drift, a deflection scale change to the left, as indicated by the above table, is necessary.

For example, if the magnetic azimuth and range to a target has been determined from the map to be—Magnetic azimuth, 4,020 mils, and the range, 1,800 yards, then the correction for drift is determined as follows: From Table I it is found that the drift at 1,800 yards is approximately 23 mils to the right. Therefore, 4,020 minus 23 equals 3,997 mils, magnetic azimuth corrected for drift.

Another example is as follows: The magnetic azimuth has been determined to be 15 mils and the range 2,000 yards. From Table I, it is found that the drift at 2,000 yards is 25 mils to the right. 15 mils minus 25 equals -10. 6,400 mils minus 10 equals 6,390 mils magnetic azimuth corrected for drift.

TABLE II. Deflection deviations caused by flank wind (3.00 or 9.00 o'clock)

Range, yards	Velocity of wind, miles per hour			
	5	10	15	20
400.....	<i>Mils</i> 0	<i>Mils</i> 5	<i>Mils</i> 5	<i>Mils</i> 10
800.....	0	5	10	15
1,200.....	5	10	15	20
1,600.....	5	10	20	25
2,000.....	5	15	25	30
2,400.....	10	20	30	40

For a wind blowing from the flank, the effect produced upon a projectile during its flight is to deviate it from its true flight to the right or to the left, as the case may be. This effect is called the deflection deviation. In order to counteract such an effect or deviation, a change or correction is applied to the deflection scale of the mortar. For example, a wind blowing from right to left causes a deflection deviation to the left and necessitates a deflection scale change to the right and vice versa.

The above table lists the deflection deviations caused by the various wind velocities at the various indicated ranges. Deviations at intermediate ranges and wind velocities can be obtained from the table by interpolating.

For example, the magnetic azimuth has been found to be 3 210 mils and the range 1,875 yards. The velocity of the wind has been determined to be 10 miles per hour from 3.00 o'clock. To make the necessary corrections for wind and drift, the following computations are necessary: From Table I it is found that the drift at 1,875 yards is 24 mils to the right. Corrections should then be made of 24 mils to the left for drift. From Table II it is found that the correction for wind should be 13 mils to the right. - Therefore 24 mils left minus 13 mils right equals 11 mils left; 3,210, the magnetic azimuth, minus 11 mils equals 3,199 mils magnetic azimuth, corrected for both wind and drift.

TABLE III.—Range deviations caused by head or rear wind (12.00 or 6.00 o'clock), in yards

Range, yards	Velocity of Wind, miles per hour			
	5	10	15	20
	<i>Yards</i>	<i>Yards</i>	<i>Yards</i>	<i>Yards</i>
400...	5	10	20	20
800...	10	20	30	50
1,200..	20	40	60	80
1,600..	30	60	90	120
2,000..	40	80	120	160
2,400..	50	100	150	200

For a wind blowing from the front or from the rear, the effect produced upon the projectile during its flight is to deviate it from its true flight by either diminishing its range or in-

creasing it, as the case may be. This effect is called the range deviation. In order to counteract such an effect or deviation, a change or correction is applied to the elevation scale of the mortar. For example, a wind blowing from the rear causes a plus or over range deviation and necessitates an elevation change to diminish the range and vice versa.

The above table lists the range deviations caused by the various wind velocities at the various indicated ranges. Deviations at intermediate ranges and wind velocities can be obtained from the table by interpolating.

For example, the range has been determined to be 2,000 yards and the magnetic azimuth 2,310. Meteorological instruments show that the wind is a head wind from 12.00 o'clock at 8 miles per hour. For correcting the above data for drift and wind, the following computations are necessary. From Table III it is found that a wind blowing from 12.00 o'clock at 8 miles per hour at 2,000 yards will decrease the range by 70 yards. Therefore, on setting the elevation of the mortar on the range table, the elevations should be set at 2,070 yards instead of at 2,000 yards. The elevation would therefore be approximately 1,030 mils with 8 rings. From Table I, it is found that the drift at 2,000 yards would be 25 mils to the right, therefore the correction would be 2,310 minus 25 equals 2,285 mils magnetic azimuth corrected for drift.

TABLE IV.—Deflection and range deviations caused by wind directions from 1.00 to 2.00 o'clock, 4.00 to 5.00 o'clock, 7.00 to 8.00 o'clock, and 10.00 to 11.00 o'clock:

Range, yards	Velocity of wind, miles per hour							
	5		10		15		20	
	Deflection, mils	Range, yards	Deflection, mils	Range, yards	Deflection, mils	Range, yards	Deflection, mils	Range, yards
400.....	0	5	0	5	0	10	5	15
800.....	0	5	0	10	5	20	5	30
1,200.....	0	15	5	30	10	40	10	50
1,600.....	5	20	5	40	10	55	15	80
2,000.....	5	25	10	50	15	80	15	100
2,400.....	5	30	10	60	15	100	20	130

The above table shows range and deflection deviations at various wind velocities and at various indicated ranges, as caused by wind directions from 1.00 to 2.00 o'clock, 4.00 to 5.00 o'clock, 7.00 to 8.00 o'clock, and 10.00 to 11.00 o'clock.

Wind directions from 1.00 to 2.00 o'clock and from 4.00 to 5.00 o'clock cause deflection deviations to the left necessitating deflection scale changes to the right and, similarly, wind directions from 10.00 to 11.00 o'clock and from 7.00 to 8.00 o'clock cause deflection deviations to the right necessitating deflection scale changes to the left.

Wind directions from 1.00 to 2.00 o'clock and from 10.00 to 11.00 o'clock cause range deviations by diminishing the range, necessitating elevation scale changes to increase the range, and, similarly, wind directions from 7.00 to 8.00 o'clock and from 4.00 to 5.00 o'clock cause range deviations by increasing the range, necessitating elevation scale changes to decrease the range.

Deviations at intermediate ranges and wind velocities can be obtained from the table by interpolating.

For example, the range has been found to be 1,900 yards, the magnetic azimuth 1,300 yards and the wind 15 miles per hour from 5.00 o'clock. The following computations are necessary for correcting for wind and drift. From Table IV it is found that a wind from 5.00 o'clock at 15 miles per hour at a range of 1,900 yards would increase the range to approximately 75 yards, so that the shell would go 75 yards beyond the target. In order to avoid this, 75 yards are subtracted from the 1,900 yards, which will give a corrected range of 1,825 yards. From Table I it is found that the drift at 1,825 yards will be 23 mils. The magnetic azimuth 1,300 minus 23 equals 1,277 mils magnetic azimuth corrected for drift. From Table IV it is found that a wind from 5.00 o'clock at 15 miles per hour will carry the shell approximately 14 mils to the left; therefore, 1,277 plus 14 equals 1,291 magnetic azimuth corrected for both wind and drift.

APPENDIX III

SAFETY REGULATIONS FOR RANGE FIRING

	Paragraphs
Section I. General.....	1-9
II. Ranges.....	10-15
III. Precautions for firing.....	16-21

SECTION I
GENERAL

1. The regulations contained in this appendix are extracts from Training Regulations No. 140-5—Range Regulations for Firing Ammunition in Time of Peace, which prescribes the general safety measures necessary in the firing or other use of live ammunition by chemical troops in time of peace. The purpose is to reduce to the absolute minimum the possibility of accidents. Safety precautions covering the 4.2-inch chemical mortar are given in paragraph 15, Part I, of this pamphlet. They will be followed carefully in addition to the precautions covered herein.

2. It is obviously impossible for any general range regulations to cover each local situation completely. Such additional regulations as may be necessary to meet local conditions will, therefore, be prepared and enforced by the post, camp, or station commander.

3. In all firing in time of peace thorough precautions for safety designed to preclude all possibility of accident, will be taken. Safety in firing is the responsibility of the officer in charge of the firing at a particular point or locality, except for those features prescribed by the orders or regulations of higher authority. When several units are firing independently in the same general area there will be an officer in charge of each firing point. The officer in charge is assisted when necessary by a range officer, who keeps the danger area clear, and in all artillery firing by the safety officer who verifies that the guns are laid safely before firing. There will be a safety officer for each artillery unit firing and he will have no other duty than that of safety officer.

4. Any individual in the military service who observes a condition which makes firing dangerous will immediately command "Cease firing," and, if at a distance from the unit firing, will make the prescribed signal therefor.

5. Any alteration of loaded ammunition, except in accordance with specific instructions from the chief of the supply service concerned, is hazardous and is, therefore, prohibited.

6. Firing over the heads of any personnel, with either shell, shrapnel, or chemical ammunition, is prohibited, except with

cannon of 105-mm. caliber or smaller, and then only when adequate protection is furnished in each instance.

7. In all cases where firing, except with blank ammunition, is to be conducted, a warning order will be published to the entire garrison, at least 24 hours prior to the time of firing, showing the nature of the firing, the place where the firing is to be conducted, the hour firing is to begin and cease each day, the number of days firing will continue, the boundaries of the danger area, and the officer responsible for the firing.

8. All ammunition at the firing point must be so placed that it will be impossible to ignite, explode, or detonate it in case of an accident at the gun position. It should be in a dry place and protected from the direct rays of the sun by a tarpaulin or other covering. Erratic shots and possibly dangerously high powder pressures may result because of overheated ammunition.

9. After firing on a range has been completed and before free access to it is allowed to personnel in general, the range should be thoroughly policed and all duds should be destroyed by competent personnel as prescribed in Section II, TR 1370-A.

SECTION II

RANGES

10. Before firing, the danger area will be examined and all persons and livestock will be excluded therefrom.

11. Range guards, properly instructed as to their duties, will be posted so as to cover all approaches to the danger area.

12. Red danger flags and, when deemed necessary, warning signs will be displayed at appropriate points to warn persons approaching a firing area which is being used. A red streamer will be displayed from a prominent point on all ranges and at all times during firing. No firing will take place unless the red streamer is displayed, and all firing will cease at once in case the streamer is hauled down during firing. At night red lights may be used in lieu of flags. Signs, warning persons of the danger from duds, will be posted in the vicinity of the firing area at all times. For the removal of duds see TR 1370-A.

13. Safety limits for mortar positions will be determined before hand and for the 4.2-inch chemical mortar, the danger area should consist of a trapezoid with the shorter base passing

through the position of the weapon and perpendicular to the line of fire; the line of fire bisecting the trapezoid. The dimensions of the trapezoid should be as follows: 3,000 yards long, 200 yards wide at the mortar position, and 600 yards at the farther end.

14. When chemical shells are fired, observers should be to windward of the line of fire.

15. When white phosphorus shells are fired, no person except the man handling the lanyard shall be within 50 yards of the mortar. White phosphorus shells must be piled well away from personnel shelter and in a space cleared of all combustible material. This type of shell should not be fired on a range overgrown with brush or tall grass on account of fire hazard.

SECTION III

PRECAUTIONS FOR FIRING

16. When chemical ammunition, other than smoke is fired, all persons will be provided with serviceable gas masks. When vesicant gas is fired, protective clothing, in addition to serviceable gas masks, will be provided.

17. Cover sufficient to provide positive protection against premature bursts in or out of the bore, as required when high explosive ammunition is fired, is not necessary when chemical shells are fired.

18. When chemical mortars are fired, no person will be allowed directly in the rear of the piece.

19. When toxic ammunition is fired from chemical mortars, no person will be allowed within 75 feet of the piece, the shell being dropped into the bore by means of a lanyard.

20. Unprotected persons will not be permitted within the danger area, as specified in paragraph 13, and in no case will any person be closer to the target, even though provided with authorized cover, than 200 yards. Persons within the danger zone or area will be provided with overhead cover as follows:

Material	Thickness in feet
Undisturbed, compact earth.....	5
Compact chalk or limestone soil.....	3
Sandstone or granite soil.....	2
Loose, freshly turned earth.....	10

Material	Thickness in feet
Earth, packed or tamped.....	7
Broken stone.....	3
Logs, not less than 8 inches in diameter, secured in place....	2
Solid masonry, brick, stone, or unreinforced concrete.....	1.5
Reinforced concrete.....	1

21. When misfires occur with the chemical mortar, the mortar will not be touched until at least one minute has elapsed from the time of misfire. When the projectile is being removed, care should be taken that all persons are at the sides of the mortar.



RANGE TABLE FOR 4" MORTAR

Ring Type Propellant

Cartridge: Green, 12 gauge, Shotgun Shell

Powder:

Cartridge: 120 grs. Flake Ballistite, Winchester

Rings: 375 grs. Hivel, No. 2

Projectile: Shell, weight 25 lbs.

From the result of test firing conducted under the supervision of the
Commandant, The Chemical Warfare School, January, 1926.

Range yards	1 RING		2 RINGS		3 RINGS		4 RINGS	
	Eleva- tion Mils.	Time of Flight Secs.	Eleva- tion Mils.	Time of Flight Secs.	Eleva- tion Mils.		Eleva- tion Mils.	Time of Flight Secs.
200	1350	13.1						
225	1320	13.0	1400	17.6				
250	1285	12.9	1380	17.5				
275	1255	12.8	1360	17.4	1408	20.4		
300	1220	12.7	1340	17.3	1390	20.3		
325	1190	12.6	1318	17.1	1372	20.2		
350	1160	12.5	1296	17.0	1354	20.0	1404	23.5
375	1115	12.4	1274	16.9	1336	19.9	1390	23.4
400	1030	11.6	1252	16.8	1318	19.7	1376	23.2
425	925	10.7	1230	16.6	1300	19.6	1362	23.1
450	815	9.7	1208	16.5	1282	19.5	1348	22.9
475			1187	16.4	1265	19.3	1334	22.8
500			1166	16.3	1248	19.2	1320	22.6
525			1145	16.2	1230	19.1	1306	22.5
550			1115	16.0	1212	18.9	1292	22.4
575			1085	15.8	1195	18.8	1278	22.2
600			1040	15.3	1178	18.7	1264	22.1
625			980	14.6	1160	18.5	1250	21.9
650			870	13.5	1142	18.4	1236	21.8
675					1122	18.2	1222	21.6
700					1100	18.1	1208	21.5
725					1072	17.8	1194	21.3
750					1042	17.6	1180	21.2
775					1004	17.3	1166	21.0
800					942	16.6	1152	20.9
825					880	15.9	1134	20.7
850					815	15.2	1114	20.5
875							1092	20.3
900							1068	20.0
925							1040	19.7
950							1008	19.4
975							964	18.9
1000							920	18.5
1025							878	18.0
1050							836	17.5
1075							800	17.0
1100								

Edgewood