

AD 768093

DA-1W262301A20700
AMCMS CODE: 632301.11.17500
HDL Proj: A22342

HDL-TM-73-20

MODIFIED M530A1 FUZE
FOR SHORT-RANGE MAN-PORTABLE
ANTITANK WEAPONS TECHNOLOGY (SMAWT)

by
L. Richmond

June 1973



U.S. ARMY MATERIEL COMMAND

HARRY DIAMOND LABORATORIES

WASHINGTON, D.C. 20438

APPROVED FOR PUBLIC RELEASE; DISTRIBUTION UNLIMITED.

UNCLASSIFIED

Security Classification

AD-768093

DOCUMENT CONTROL DATA - R & D

(Security classification of title, body of abstract and indexing annotation must be entered when the overall report is classified)

1. ORIGINATING ACTIVITY (Corporate author) Harry Diamond Laboratories Washington, D.C. 20438		2a. REPORT SECURITY CLASSIFICATION Unclassified	
		2b. GROUP	
3. REPORT TITLE MODIFIED M530A1 FUZE FOR SHORT-RANGE MAN-PORTABLE ANTITANK WEAPONS TECHNOLOGY (SMAWT) PROGRAM			
4. DESCRIPTIVE NOTES (Type of report and inclusive dates) Technical Memorandum			
5. AUTHOR(S) (First name, middle initial, last name) Louis Richmond			
6. REPORT DATE June 1973		7a. TOTAL NO. OF PAGES 23	7b. NO. OF REFS
8a. CONTRACT OR GRANT NO.		9a. ORIGINATOR'S REPORT NUMBER(S) HDL-TM-73-20	
b. PROJECT NO. DA-1W262301A20700			
c. AMCMS Code: 632301.11.17500		9b. OTHER REPORT NO(S) (Any other numbers that may be assigned this report)	
d. HDL Proj: A22342			
10. DISTRIBUTION STATEMENT Approved for public release; distribution unlimited			
11. SUPPLEMENTARY NOTES		12. SPONSORING MILITARY ACTIVITY U.S. Army Munitions Command	
13. ABSTRACT This report describes the status of a program to modify the M530A1 Fuze for use with SMAWT warheads. Principal modifications consist of (1) providing a second environmental sensor to satisfy requirements of MIL-STD-1316A, and (2) providing crush switch initiation (rather than piezoelectric initiation) to improve reliability on impact with nonconventional armor. This work has been extremely successful; thirty-five modified M530A1 fuzes have been tested for arming and for impact function in the MICOM rocket delivery system, with all units functioning properly.			

Reproduced by
NATIONAL TECHNICAL
INFORMATION SERVICE
U S Department of Commerce
Springfield VA 22151

DD FORM 1473
NOV 65

REPLACES DD FORM 1473, 1 JAN 64, WHICH IS
OBSOLETE FOR ARMY USE.

UNCLASSIFIED
Security Classification

27

1

14. KEY WORDS	LINK A		LINK B		LINK C	
	ROLE	WT	ROLE	WT	ROLE	WT
SMAWT Antitank fuzing HEAT fuzing						

wa

ABSTRACT

This report describes the status of a program to modify the M530A1 Fuze for use with SMAWT warheads. Principal modifications consist of (1) providing a second environmental sensor to satisfy requirements of MIL-STD-1316A, and (2) providing crush switch initiation (rather than piezoelectric initiation) to improve reliability on impact with non-conventional armor. This work has been extremely successful; thirty-five modified M530A1 fuzes have been tested for arming and for impact function in the MICOM rocket delivery system, with all units functioning properly.

Preceding page blank

FOREWORD

The current infantry lightweight antitank weapon, the M72 Light Antitank Weapon (LAW), is seriously deficient in first-round kill probability at ranges beyond approximately 100 m. The Short-Range Man-Portable Antitank Weapons Technology (SMAWT) program is a research (6.2) effort intended to establish the technical parameters of a new weapons system capable of meeting current effectiveness requirements. Two competing delivery systems intended for use with HEAT warheads are being examined, a rocket system and a recoilless rifle system. The Army Missile Command has management responsibility for the rocket concept, and the Army Weapons Command for the recoilless rifle concept. A fuze is being developed by the Harry Diamond Laboratories for use with either delivery system.

CONTENTS

ABSTRACT.....	3
FOREWORD.....	5
1. INTRODUCTION.....	9
2. GENERAL DESCRIPTION.....	9
3. STATUS.....	17
3.1 Drag Sensor Design and Test.....	17
3.2 Complete Fuze Tests.....	19
3.3 Mathematical Model.....	20
3.4 Logic Circuit.....	21
3.5 Safety Requirements.....	22
4. FUTURE PLANS.....	22
5. CONCLUSIONS.....	22
6. RECOMMENDATION.....	23
DISTRIBUTION.....	25

FIGURES

1. Conventional PIBD fuzing system.....	11
2. M530A1 fuze.....	11
3. Condition prior to launch.....	12
4. Condition following normal launch (drag exceeds 4 g).....	12
5. Condition on completion of arming.....	13
6. Condition following release of rotor without drag signature (rotor locked in fail-safe position).....	13
7. Concept drawing of PIBD fuze employing crush switch initiation.....	15
8. Basic Firing Circuit.....	15
9. Inertial Impact Switch.....	16
10. Modified M530A1 fuze with electronic module and drag sensor; superfluous metal removed and mechanical graze element deleted.....	17

1. INTRODUCTION

In February of 1972, HDL was requested by Headquarters, Army Materiel Command, to perform a fuzing study for the Short-Range Man-Portable Antitank Weapons Technology (SMAWT) program. The purpose of this study was to determine whether any existing standard fuze for HEAT ammunition was suitable for, or could readily be modified for use with the two proposed SMAWT delivery systems, or whether a completely new development program was required.

The principal problem was to satisfy the dual environmental safety requirement of MIL-STD-1316A. Another important consideration was the overcoming of the deficiency of conventional PIBD fuzing against non-conventional armor.

In May of 1972, an informal HDL report was submitted to AMC. This report concluded that an existing standard fuze, the M530A1, could be modified with moderate development effort to meet the additional safety and performance requirements, and would perform satisfactorily with either delivery system.

Dual environmental safety can be achieved by incorporating a drag sensor in the fuze design. This, together with the existing setback sensor, will provide the two arming signatures required by MIL-STD-1316A.

The deficiency on nonconventional armor can be overcome by using a live power supply (a capacitor charged at launch from an external power source), with fuze function on target impact initiated by a crush switch encompassing the full ogive of the projectile.

During the past few months HDL has been engaged in a test program to demonstrate the feasibility of the recommended fuze concept. The test program was very successful; thirty-five modified dual safe M530A1 fuzes were tested in the MICOM rocket system and all units functioned properly. Dual safe modified M530A1 fuzes were prepared for test in the recoilless system also.

2. GENERAL DESCRIPTION

The fuze proposed by HDL for use with either the rocket or recoilless rifle delivery systems is a modified M530A1. This fuze was developed by HDL for use in M371 90 mm recoilless rifle ammunition, and has been produced in volume for that application. Production cost was in the \$4.00-5.00 range, at a production rate of about 500,000 per year. Although the 90 mm recoilless has a peak firing acceleration of only about 5000 g, it was demonstrated during development that the M530A1 is capable of withstanding very high firing accelerations, on the order of 40,000 g. The fuze therefore has adequate ruggedness for either of the proposed SMAWT delivery systems.

The M530A1 is a conventional electromechanical base element of the type that has been standard in U.S. HEAT ammunition for about 20 years. It is the most recent in a series of 3 piezoelectric initiated fuzes (M509, M530, M530A1) developed by HDL for PIBD (point initiated-base detonating) HEAT application. The piezoelectric element is mounted in the projectile nose, and is connected to the fuze by a wire (fig. 1).

The M530A1 fuze consists essentially of the following components: (see fig. 2).

1. A spring-driven rotor that carries an electric detonator, from the safe (out-of-line) to the armed (in-line) position.
2. A sequential leaf acceleration integrator that restrains the rotor in the safe position until the round is fired.
3. An explosive lead and booster with which the electric detonator is aligned in the armed position.
4. A runaway escapement that delays detonator alignment for approximately 50 ms after launch.
5. An electric switch that connects the electric detonator to the firing energy source (the piezoelectric crystal in the shell nose) upon rotor arming.
6. An inertial-stab graze sensitive element that detonates the fuze in the event that electrical initiation does not occur.

The M530A1 fuze is approximately 1.25 in. in diameter and 2.0 in. long. Its weight is approximately 0.25 lb.

Only moderate design modification of the M530A1 is required to make it suitable for use with either SMAWT delivery system. The required modifications are as follows:

1. A second environmental sensor is added, in addition to the setback integrator, in accordance with the requirements of MIL-STD-1316A. This is a drag sensor that responds to a drag deceleration of 4 g in the rocket application. For the recoilless application, a higher drag deceleration, up to about 8 g, is acceptable. The device must sense this drag during the period of rotor arming, in order for arming to be completed. If the drag signature is not present, safety of the system is maintained, with the rotor locked in a fail-safe position. Operation of the drag sensor is shown in figures 3-6. The drag sensor is assembled to the fuze in the space formerly occupied by the inertial graze element, and is very similar in design to that element. It operates in the following manner:

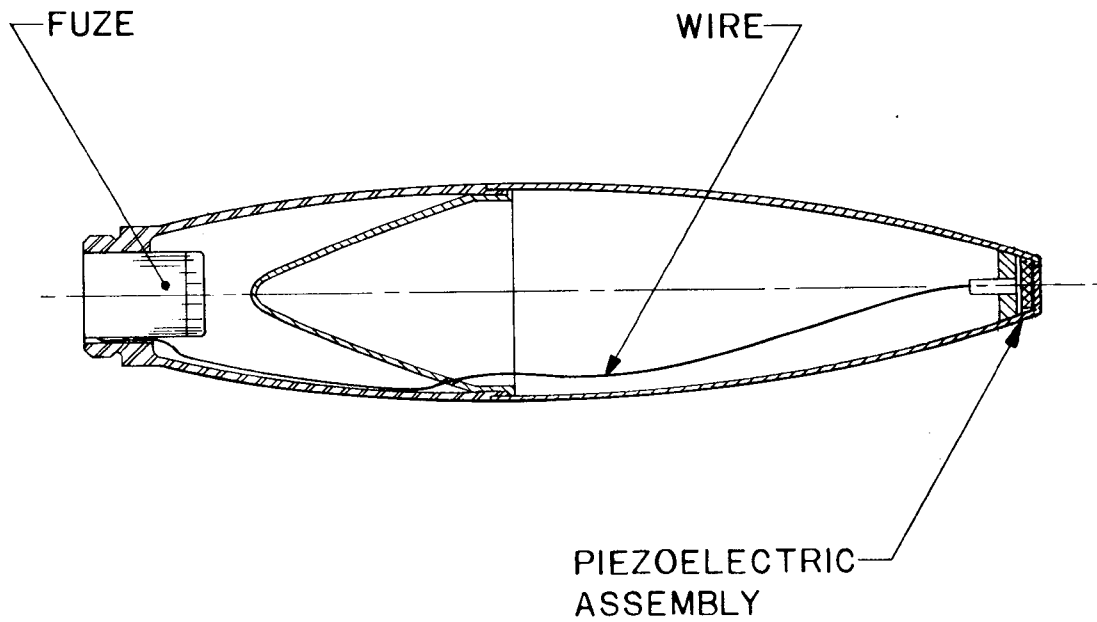

Figure 1. Conventional PIBD fuzing system.

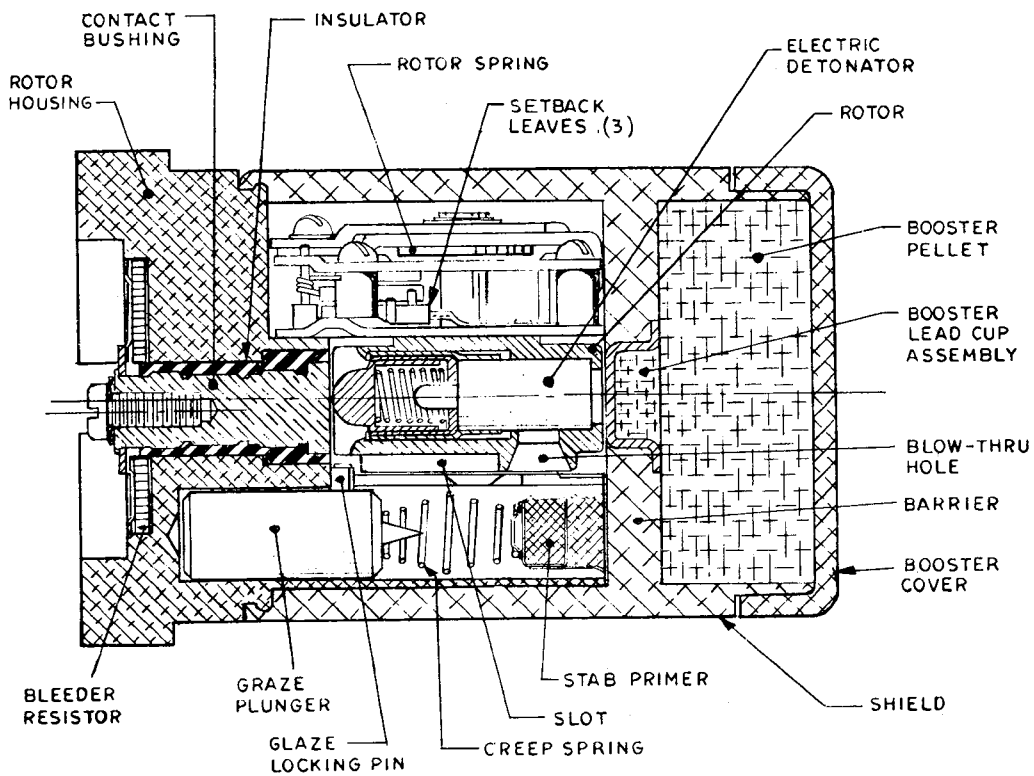

Figure 2. M530A1 fuze.

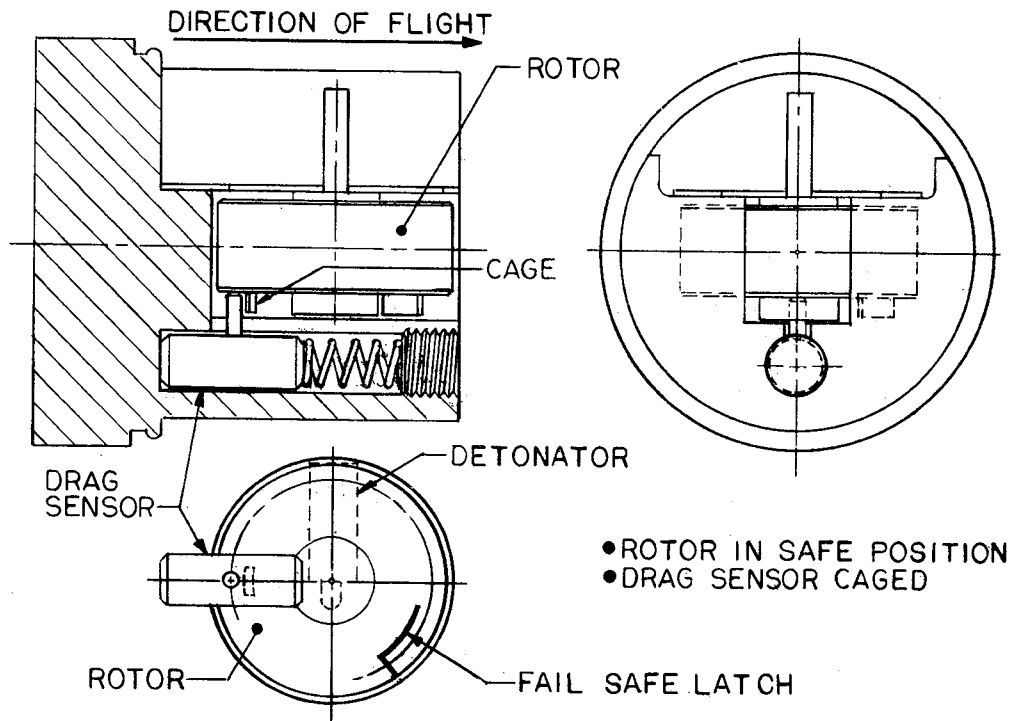

Figure 3. Condition prior to launch.

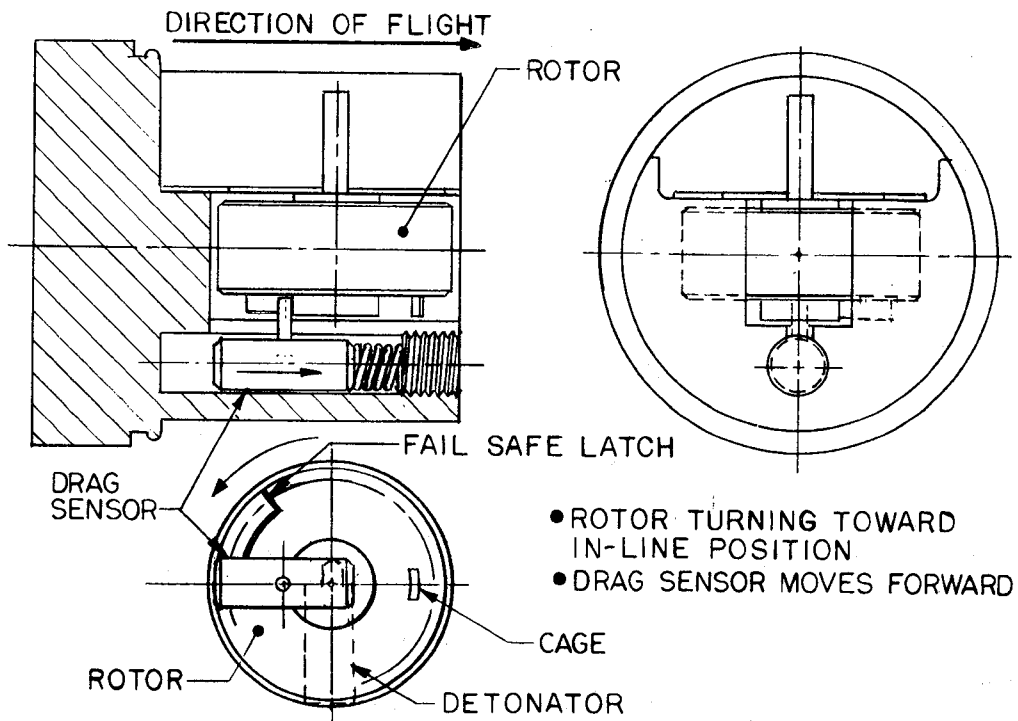

Figure 4. Condition following normal launch (drag exceeds 4 g).

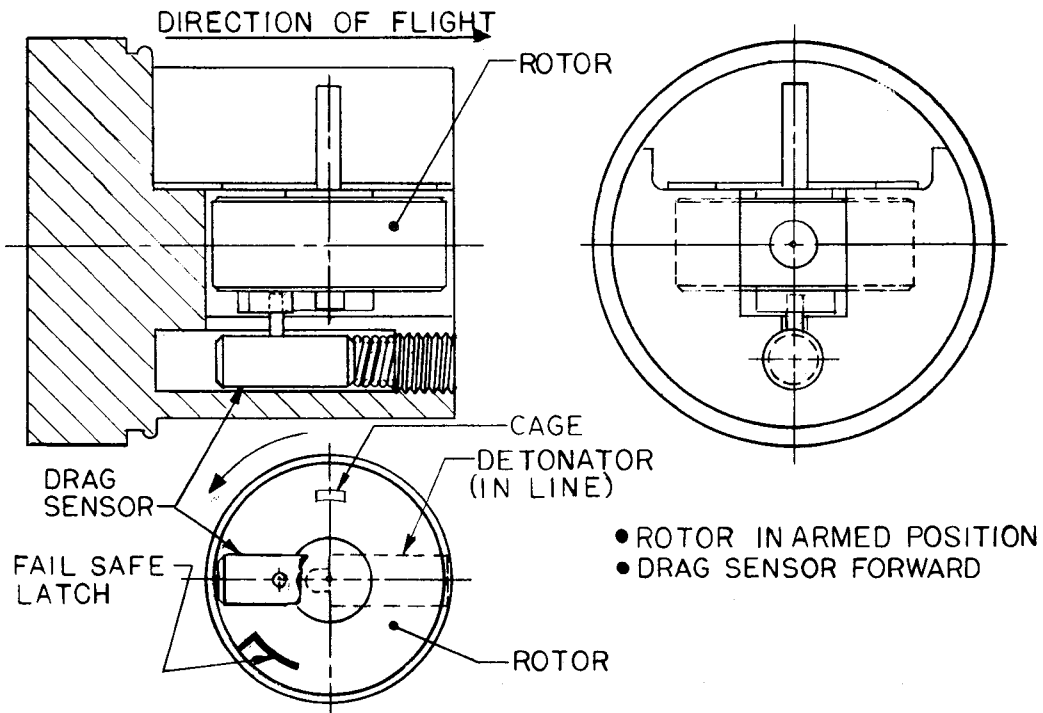

Figure 5. Condition on completion of arming.

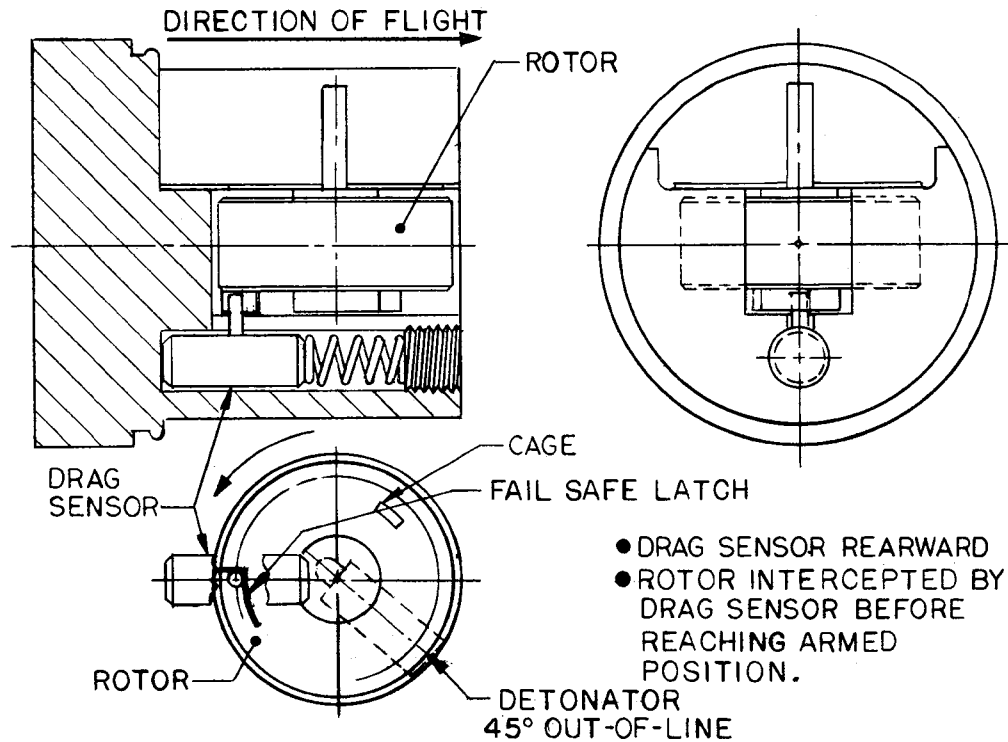

Figure 6. Condition following release of rotor without drag signature (rotor locked in fail-safe position).

a. Upon projectile launch, firing acceleration operates the setback integrator, releasing the spring-driven rotor. When the firing acceleration falls to about 50 g, the spring begins to turn the rotor toward the armed position.

b. The rotor is damped by a runaway escapement, and requires (for the SMAWT application) at least 30 ms to turn from the safe to the armed position. As the rotor starts to turn, following normal firing, projectile acceleration drops to zero at or near the launcher exit, and then becomes negative under influence of aerodynamic drag forces. When this occurs, the drag sensor moves forward against its restraining spring, as shown in figure 4. In order for arming to be completed, the drag sensor must move forward about 0.1 inch before the rotor completes approximately 205 deg of its total motion. If this forward motion of the drag sensor occurs, the rotor will continue in its travel for the full 270 deg and reach the fully armed (detonator in line) position shown in figure 5. However, if the drag signature is not present after release of the rotor by the setback sensor, the drag sensor will be held in a rearward position by its spring as the rotor turns toward the armed position. In this condition, the fail-safe latch on the rotor engages a pin protruding from the drag sensor, and the rotor becomes permanently locked in a position 45 deg from the armed position (fig. 6).

c. At this point, the explosive train is still not aligned, and the fuze becomes a dud. For fuze arming to occur, drag (negative acceleration) must be present in a critical time relationship to rotor transit. A net driving acceleration of the drag sensor of approximately 2 g must exist in the period immediately after launch and be sustained for about 15 ms. If this signature is not present, the fuze will not arm. The drag sensor can provide substantial protection against the possibility of early arming caused by failure of the delayed arming mechanism. If failure of the escapement should occur, the time required for the rotor to turn 205 degrees would fall to about 10 ms, probably insufficient time for the required motion of the drag sensor, and the fail-safe condition should result.

2. The piezoelectric power source of the M530A1 is replaced by a firing capacitor charged at launch from an external power supply on the launcher. Fuze function is initiated by closure of a crush switch in the projectile nose, which connects the capacitor to the electric detonator (figs. 7 and 8).

3. The inertial-stab graze element is eliminated and this function is performed by an inertial switch that connects the firing capacitor to the electric detonator on grazing impact (assuming that the crush switch does not operate). The inertial switch is a previously developed production fuze component (fig. 9).

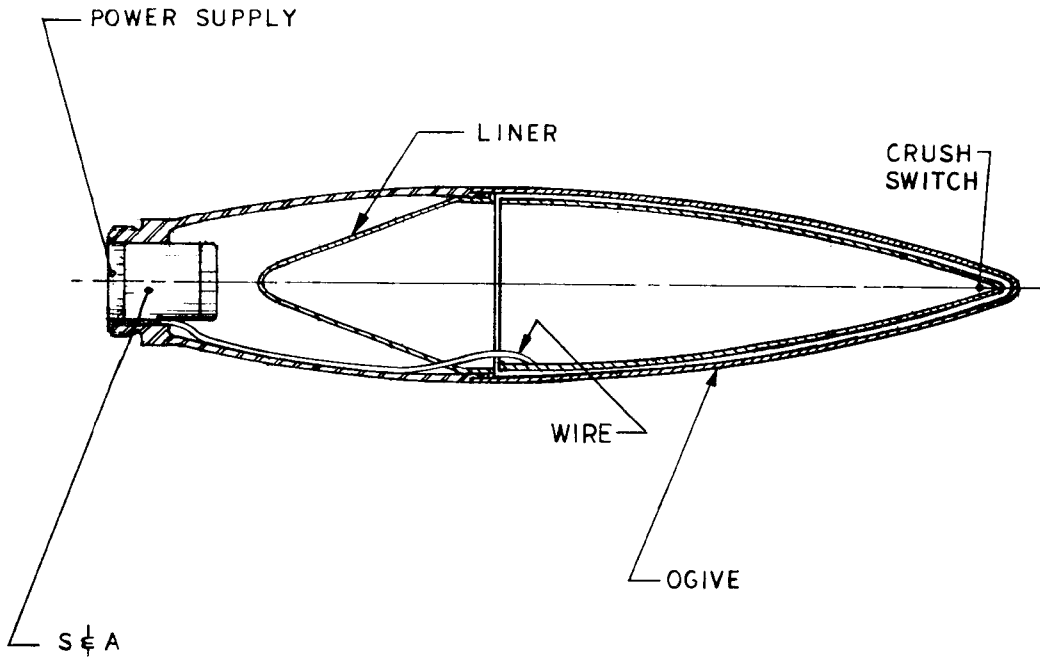

Figure 7. Concept drawing of PIBD fuze employing crush switch initiation.

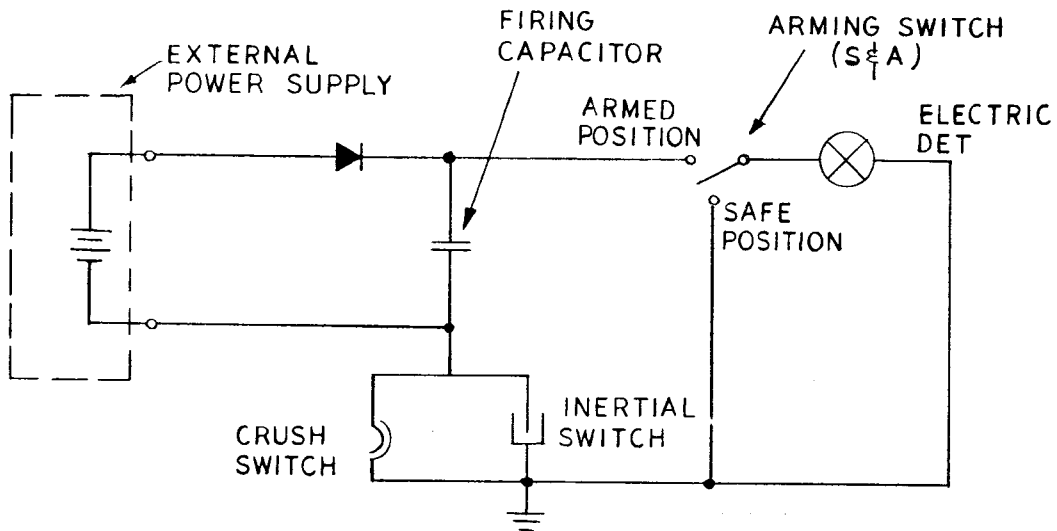

Figure 8. Basic firing circuit.

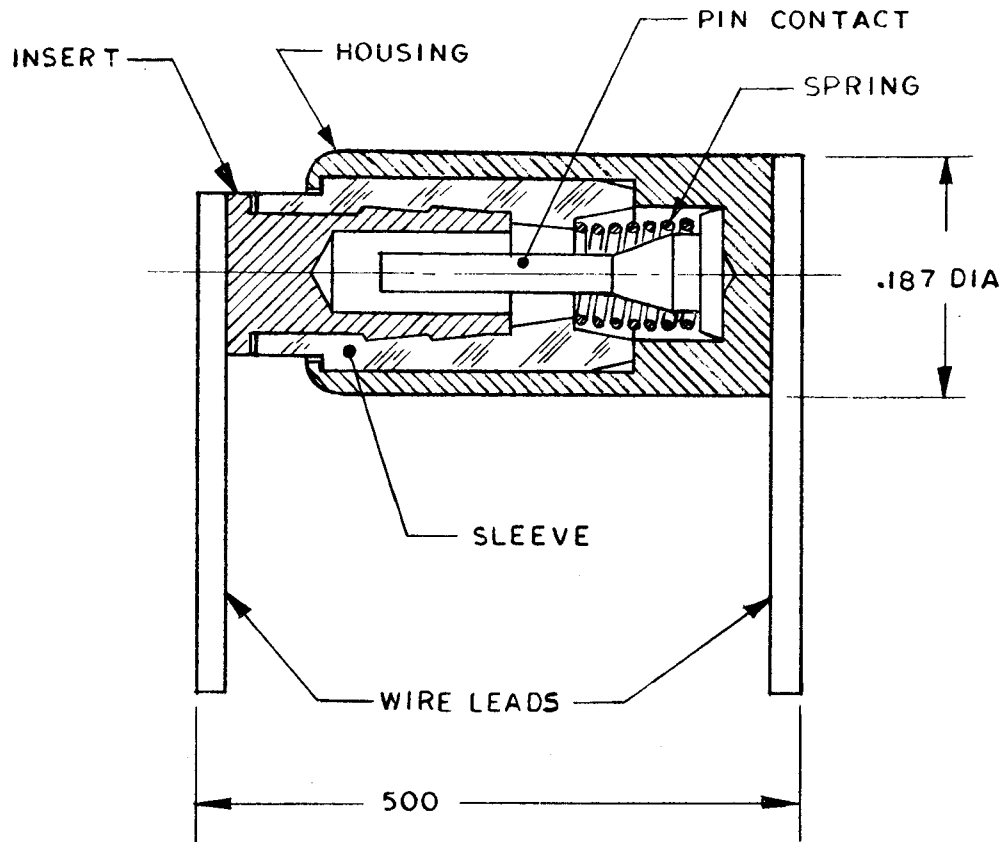

Figure 9. Inertial impact switch.

4. The carbon bridge electric detonator normally used in the M530A1 is replaced by a wire bridge detonator which can be initiated by a lower firing voltage. (Fuze power is supplied by a thermal battery on the launcher, and voltage is limited to about 18 V. This is not sufficient to initiate a carbon bridge detonator.)

5. To minimize weight, excess metal in the rotor housing is removed, and the rotor material changed from brass to aluminum.

6. For additional safety, logic circuitry (in integrated circuit form) will be added to detect a damaged or malassembled fuze and to preclude the possibility of fuze function on launch or on arming.

Physical dimensions of the final fuze design will be approximately 1.25 in. in diameter and 1.85 in. long. Final weight of the modified fuze will be about 0.20 lb.

A proposed engineering development (ED) design of the modified M530A1 fuze is shown in figure 10.

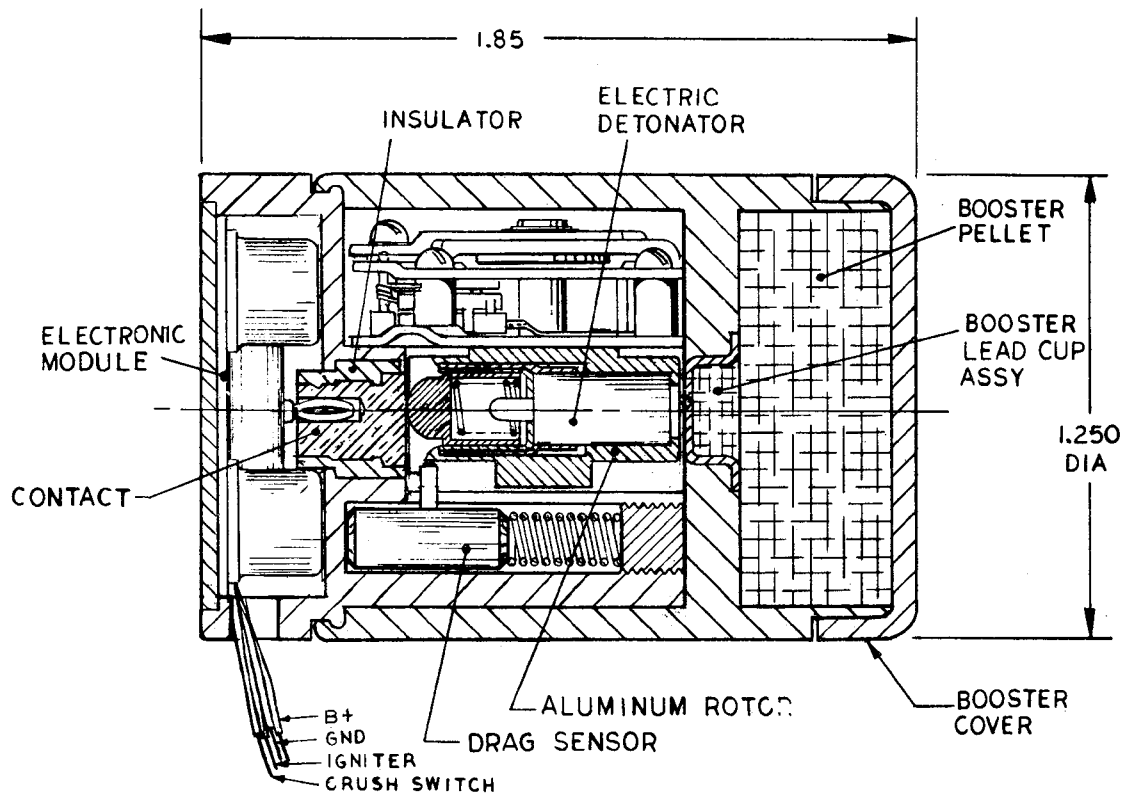

Figure 10. Modified M530A1 fuze with electronic module and drag sensor; superfluous metal removed and mechanical graze element deleted.

3. STATUS

3.1 Drag Sensor Design and Test

The principal emphasis to date during the technology program has been placed on demonstrating the feasibility of the M530A1 fuze modified to include the second environmental (drag) sensor.

Initial evaluation tests were performed in a laboratory centrifuge which was used to simulate projectile drag. The design constraints which were applied were as follows:

1. The drag sensor must prevent arming when the rotor is released in any static (1 g) position of the fuze (simulating a spontaneous failure of the acceleration sensor during storage).

2. The drag sensor must permit the fuze to arm under the minimum longitudinal drag condition anticipated in the SMAWT rocket, about 4.5 g.

Tests in the centrifuge showed that these limits could be readily maintained. A tolerance of ± 0.5 g in operation of the drag sensor is readily attainable.

In order to fully demonstrate feasibility after preliminary lab tests, HDL thought it necessary to conduct ballistic firing tests with fuzes modified to include the drag sensor, and preferably in the SMAWT delivery systems. We considered modifying 81 mm mortar projectiles to provide drag characteristics similar to those experienced by the SMAWT rocket system (simulation of the higher drag signature experienced by the recoilless system is not feasible in mortar ammunition). However, work on modifying the mortar projectile was abandoned when HDL was advised by MICOM that ballistic testing of the modified fuze could be conducted in conjunction with MICOM's development testing of their delivery system. Test of the drag sensor in the rocket system was particularly desirable because this round experiences a much lower drag than a recoilless system. The rocket therefore represented a "worst case" arming environment, and demonstration of feasibility in this environment would preclude necessity for similar testing in the recoilless weapon, where conditions appeared more favorable for proper operation of the arming system. (Although the recoilless system has a higher firing acceleration, the M530A1 was designed to withstand such accelerations, as noted earlier in this report.)

3.1.1 Inert Fuze Tests in Rocket Ammunition

A series of 20 recovery firing tests of the modified M530A1 fuze was performed in the SMAWT rocket at Redstone Arsenal between September and November 1972. The rounds were fired in downrange accuracy tests through soft targets, and recovered after graze angle earth impact. The fuzes were then removed and inspected. In each case, the fuze had armed properly, and was undamaged and operable.

Fuze arming could not have occurred as a result of impact with the target or the earth, since arming occurs within about the first 50 ft of air travel. If the drag sensor does not operate properly during that interval, the fuze becomes locked in the fail-safe condition shown in figure 6, and can then become armed only by subsequent mechanical failure of some part of the fail-safe interlock. Careful examination of the recovered fuze hardware showed that no mechanical failure had occurred in any of the test fuzes.

3.1.2 Fuzes for Recoilless Ammunition

A group of 10 inert dual signature fuzes was prepared for recovery testing in the recoilless ammunition being developed by Picatinny Arsenal. These modified fuzes were essentially identical to the inert fuzes tested in the MICOM rocket, with the exception that the brass rotor used in the M530A1 fuze was replaced with an aluminum rotor in the fuzes for the recoilless system. (In an ED fuze design, the aluminum rotor would be used with either delivery system, in the interest of minimizing weight. However, from a standpoint of fuze arming performance, its use is not essential in the rocket because of the relatively low drag characteristics of that round. In the recoilless system, rotor friction caused by the high drag can degrade arming reliability if a brass rotor is used, and the lighter aluminum rotor was therefore added to the fuzes to enhance arming reliability.)

After fabrication of these fuzes, HDL was advised by Picatinny Arsenal that limitation on availability of ammunition did not permit the testing of more than 5 of the fuzes, which were then furnished to Picatinny. These fuzes had not been tested at the time this report was prepared.

3.2 Complete Fuze Tests

Following successful recovery firing of inert dual-signature fuzes in the rocket system, HDL agreed with MICOM to conduct a series of firing tests of the dual-signature fuze in high explosive rocket ammunition. In these tests, it was decided to use the method of fuze initiation proposed for use in the ED weapon design; crush switch initiation of a fuze with on-board power (figs. 2 and 3, except that the inertial switch shown in fig. 3 was not included in these fuzes).

3.2.1 Fuze Design

For the fuze, this test required, in addition to the drag sensor:

1. Addition of a firing capacitor (and a protective diode) which could be charged from an external power supply on the launcher.
2. Provision for making electrical connection from the launcher power supply to the fuze, by means of 2 wires passing through the wall of the fuze cavity.
3. Provision for connecting two lead wires from the crush switch to the fuze.

A small circuit board with the foregoing features was designed for assembly to the base of the fuze. Space for the circuit board was provided by removal of excess material at the base of the rotor housing.

Three sample circuit boards were assembled to the modified rotor housings and potted to withstand high firing acceleration. The 3 units were then air-gun tested at 20,000 g, and were undamaged and operable after this test.

3.2.2 Crush Switch

The crush switch to be used in the HE tests was designed by MICOM with technical support by HDL. MICOM performed all stress analysis, and fabricated all test hardware. HDL reviewed the design for structural integrity, anticipated response characteristics, electrical conductivity, suitability of electrical connections, etc. Two prototype crush-switch assemblies were then fabricated for air-gun tests at HDL. The units were tested at 12,000 g, without damage. One unit was then tested in the air gun for functional response characteristics. In this test, the crush switch was placed in a stationary mount, and impacted with a metal target projectile at a velocity of about 500 fps. Closure of the crush switch was used to initiate an M84 detonator, using as the power supply a capacitor with the same firing voltage and energy as that in the actual fuze. High speed photographs showed that the detonator was initiated with minimal delay after the switch had crushed to the point of closure.

3.2.3 Fuze Fabrication

Following the successful air-gun tests, a group of 15 fuzes was fabricated and delivered to MICOM for HE rocket tests. Since these fuzes were intended for use in connection with the system demonstration program, fabrication of this fuze hardware was separately funded by MICOM. HDL also designed, fabricated, and furnished to the Picatinny Arsenal warhead design group, high strength lead wire assemblies which were used to connect the fuzes to the crush switch comprising the nose of the projectile. The warhead design of the projectile is such that it is necessary to assemble the lead wires to the warhead before the projectile is filled with high explosive. Agreement was reached with MICOM and the Picatinny Arsenal warhead designers regarding optimum methods of assembling the fuze and wire connection described above.

3.2.4 Test of Fuzes in HE Ammunition

The 15 live fuzes were assembled to HE loaded rocket ammunition and fired against armor plate targets at ranges of 250 meters and 500 meters from the launcher. These tests were conducted at Redstone Arsenal and Aberdeen Proving Ground. All 15 fuzes functioned properly on impact with the target.

3.3 Mathematical Model

A mathematical model of the dual-signature arming system is being prepared. This model considers the effects of the various ballistic environments on fuze arming characteristics. It is intended to determine, for each delivery system, such factors as:

4. Feasibility of the arming concept is supported by results of the mathematical model.
5. Based on the opinions of the HDL S&A Certification Board and the Picatinny Arsenal Safety Committee, the dual-safety signature concept of the M530A1 fuze satisfies the intent of MIL-STD-1316A.
6. RECOMMENDATION

Development of this fuze should be continued for use in either of the proposed delivery systems.

1. The minimum arming delay which is compatible with the drag sensor concept now employed.
2. The nominal sensitivity and functional tolerance required for the drag sensor.
3. The effect on arming of environment, such as spin, yaw, pitch, etc.

This model is well advanced. The preliminary data (substantiated by field tests described earlier) indicate that the proposed arming system is compatible with the anticipated arming delay requirements for the weapons systems, and system tolerances required to assure proper performance are well within the manufacturing state-of-the-art.

3.4 Logic Circuit

The fuze control logic circuit has been breadboarded. This control circuit is designed to perform the following functions:

1. If either the crush switch or inertial impact switch is short-circuited at the instant of launch, the logic circuit prevents the fuze from functioning on arming because of the defective switch. Proper fuze functioning will be initiated on impact by the remaining switch.
2. If both of the switches are short circuited, the logic circuit aborts the launch by prohibiting initiation of the propellant igniter.
3. If the fuze should become armed because of some unforeseeable mishap, the logic circuit precludes possibility of a function on launch by limiting current in the firing circuit. Also, launch of the projectile is aborted.

Testing of the breadboard is scheduled to be completed by 30 June 1973, at which time the circuit will be ready for miniaturization required for use in fuze firing tests. The excellent safety record of the M530A1 fuze, even without the extra safety afforded by the dual environmental sensor, suggests that the probability of a prearmed fuze is extremely remote. Furthermore, since the projectile will be pre-assembled to the launcher, it is highly unlikely that the fuze might sustain damage which would cause a short-circuited impact switch, without at the same time damaging the launcher to the point that use of the ammunition is precluded. It is therefore considered questionable whether the additional fuze cost and complexity associated with the logic circuit can be justified.

3.5 Safety Requirements (MIL-STD-1316A)

The HDL Safety and Arming Certification Board met on 2 March 1973 to consider safety of the modified M530A1 fuze concept, particularly with respect to MIL-STD-1316A. It was the Board's opinion that the concept of the modified M530A1 meets or exceeds the requirements of MIL-STD-1316A.

The Picatinny Arsenal Safety Committee met to consider this fuze concept on 9 March 1973. The committee concluded that "the design concept complies with the requirements of MICOM Regulation 705-11, and meets the intent of MIL-STD-1316A provided a caging device is included in the design to restrain the drag sensor in its original position until after the rotor has begun to turn as part of the arming sequence." (Note: A caging device is included in the design, and has been used in all lab and field tests of the fuze.)

4. FUTURE PLANS

1. HDL will continue to test and evaluate the modified M530A1 fuze in the laboratory to advance the concept toward an ED type prototype.
2. Additional firing tests will be performed, depending on availability of ammunition. Fuzes identical to those described in paragraph 3.2 have been prepared for firing in the MICOM rocket. These will be used in a planned demonstration at Aberdeen Proving Ground.
3. The mathematical model of the fuze will be completed.
4. Testing of the logic circuit breadboard will be completed. Other, less complex and costly methods of detecting a damaged or defective fuze also will be explored.

5. CONCLUSIONS

The following conclusions have been reached:

1. Feasibility of the dual signature (setback and drag) arming concept has been demonstrated in the MICOM rocket delivery system.
2. Feasibility of crush switch initiation of a fuze using a capacitor power supply has been demonstrated in the MICOM rocket.
3. Because the recoilless system has a much stronger drag signature than the rocket, we expect no difficulty in using this arming signature in the recoilless system (the M530A1 fuze has already been shown to be sufficiently rugged for use in the recoilless system).