

WILS
GOVU
D 101.20:23-6

FM 23-6

DEPARTMENT OF THE ARMY FIELD MANUAL

ANTITANK GUIDED MISSILE (ENTAC)



HEADQUARTERS, DEPARTMENT OF THE ARMY
MAY 1964

TAGO 8637A

FIELD MANUAL }
 No. 23-6 }

HEADQUARTERS
 DEPARTMENT OF THE ARMY
 WASHINGTON, D. C., 13 May 1964

ANTITANK GUIDED MISSILE (ENTAC)

	Paragraphs	Pages
CHAPTER 1. INTRODUCTION		
Section I. General.....	1, 2	2
II. Description.....	3, 4	2
CHAPTER 2. MECHANICAL TRAINING		
Section I. Assembly and preparation for firing.....	5-7	6
II. Principal components and functions.....	8-18	15
III. Malfunctions and immediate action.....	19-21	37
IV. Maintenance and storage.....	22-25	38
V. Decontamination procedures.....	26, 27	40
VI. Destruction in event of imminent capture.....	28-31	40
CHAPTER 3. PREPARATORY MARKSMANSHIP TRAINING		
Section I. Preparatory training.....	32, 33	43
II. Simulator training.....	34, 35	43
III. Crew drill.....	36-41	51
IV. Range procedures and safety.....	42, 43	59
CHAPTER 4. TECHNIQUE OF FIRE		
Section I. General.....	44, 45	63
II. Range determination.....	46, 47	63
III. Fire commands.....	48, 49	65
IV. Range cards.....	50, 51	66
V. Night firing and field firing.....	52, 53	66
VI. Methods of employment.....	54-60	68
CHAPTER 5. ADVICE TO INSTRUCTORS.....	61-63	81
APPENDIX REFERENCES.....	-----	83
INDEX.....	-----	84

*This manual supersedes TC 23-6, 21 June 1962, including C 1, 21 August 1963.

CHAPTER 1

INTRODUCTION

Section I. GENERAL

1. Purpose and Scope

This manual provides guidance for commanders, instructors, and other interested personnel presenting instruction and training on the French manufactured ENTAC (ENgin-Télguidé Anti-Char) antitank guided missile. It covers the description, assembly, functioning, employment, and considerations necessary for training on this missile and associated equipment. It is applicable to both nonnuclear and nuclear warfare. Tactical employment is included in FM 7-20.

2. Improvement of the Manual

Users are encouraged to submit recommended changes or comments to improve this manual. Comments should be submitted on Department of the Army Form 1598 and should be keyed to the specific page, paragraph, and line of the text in which the change is recommended. Reasons should be provided for each comment to insure understanding and complete evaluation. Forward comments to Commandant, U.S. Army Infantry School, Fort Benning, Ga.

Section II. DESCRIPTION

3. Missile Description

a. General. The ENTAC (fig. 1) is a light, no roll stabilized, remote controlled, wire guided missile intended for use against ground targets. It is primarily an antitank weapon, but can be used effectively against gun emplacements, roadblocks, and fortifications.

- (1) The missile has four fins or wings, each equipped with a remote controlled spoiler that acts as a controlling surface. It is brought into alinement and guided to the target by the gunner, who initiates guidance commands with a manually operated control stick. Guidance commands are transmitted to the missile through two conducting wires that unwind from within the missile during flight. The missile flies in a "nose-up" attitude on an angle of six degrees above the horizontal.
- (2) The missile is launched and propelled by two solid propellant rocket motors which burn in series. The first, or

booster motor, launches and accelerates the missile to its flying speed; the second, or sustainer motor, maintains this speed throughout the missile's flight.

- (3) The ENTAC is armed and fired electrically. The warhead is equipped with an electrical fuze which, upon impact, completes a circuit back to the detonator causing the warhead to explode. The ENTAC missile carries a 130-mm, high explosive, antitank (HEAT) warhead. Practice and dummy missiles are provided for training. The practice head is inert but has the same ballistic characteristics as the 130-mm HEAT.
- (4) The ENTAC antitank guided missile is type classified standard A.

b. Detailed Description.

(1) *Missile.*

Total weight.....	27 lb., 12.25 kg.
Cruising speed.....	80 meters per sec., 180 mph.

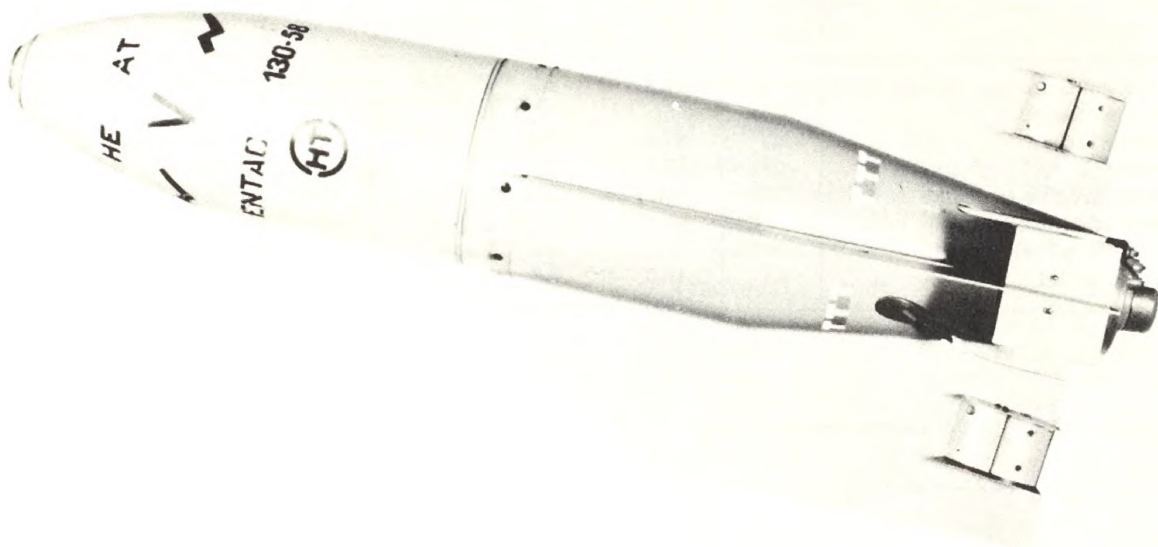

Figure 1. The ENTAC missile.

Propelled flight time.....25 sec. (approx.)
 Maximum practical range 2,000 meters
 Minimum practical range 400 meters
 Dimensions (fig. 2).

(2) *Launching container.*

Weight..... 10.8 pounds, 4.9 kilograms.
 Height..... 10.8 inches, 27.5 centimeters.
 Width..... 10.8 inches, 27.5 centimeters.
 Length..... 19 inches, 48.3 centimeters.

(3) Total weight of missile in its launcher container is 37.5 pounds or 17.0 kilograms.

(4) *Shipping container.*

Weight..... 44.5 pounds, 20.2 kilograms.
 Height..... 13.4 inches, 34 centimeters.
 Width..... 13.1 inches, 33.5 centimeters.
 Length..... 27.7 inches, 70.4 centimeters.

(a) Markings (fig. 17). Each shipping container, storing a missile with a

live motor, is marked by yellow trihedrons on two diagonally opposed corners. A rocket symbol on the side of the shipping container will indicate the forward end of the missile body. Type and size of warhead, weight, volume, ammunition lot number, storage temperature range, and other information will be stenciled on the container.

(b) Contents and markings.

Contents	Type of Charge	Color of Trihedron
130-mm HEAT	Shaped charge	Yellow.
Inert, with live motor, (TP).	Inert	Brown.
Inert, without motor.	Dummy	None.

(5) *Warheads.*

Type	Diameter of Charge	Weight		Length		Color	Warhead marking	Fuze marking
		Pounds	Kilograms	Inches	Centimeters			
HEAT	130-mm	8.7	3.9	13.8	35.1	OD	>	<
Inert	N/A	8.7	3.9	13.8	35.1	Blue	>	<

(6) Guidance equipment.

Item	Length		Width		Height		Weight	
	Inches	Centi-meters	Inches	Centi-meters	Inches	Centi-meters	Pounds	Kilo-grams
TR-10 guidance control unit w/cover.	7.4	18.8	8.5	21.6	12.0	30.5	28.4	12.9
Selection box	8.4	21.3	7.4	18.8	3.8	9.7	10.9	4.9
Battery	7.4	18.8	2.2				3.0	1.4
One hundred meter cable with reel and stand.	15.7	39.9	11.3	28.7	17.3	40.0	47.2	21.4
Ten meter missile cable							3.5	1.6
Circuit test set	5.1	13.0	6.7	17.0	7.8	19.8	5.5	2.5

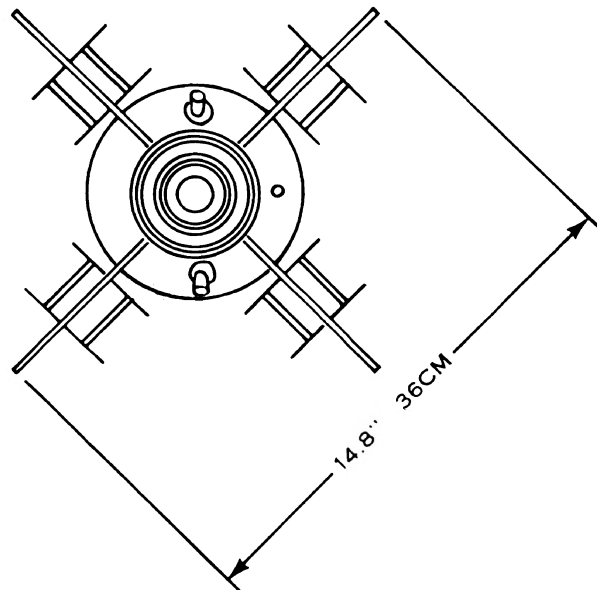
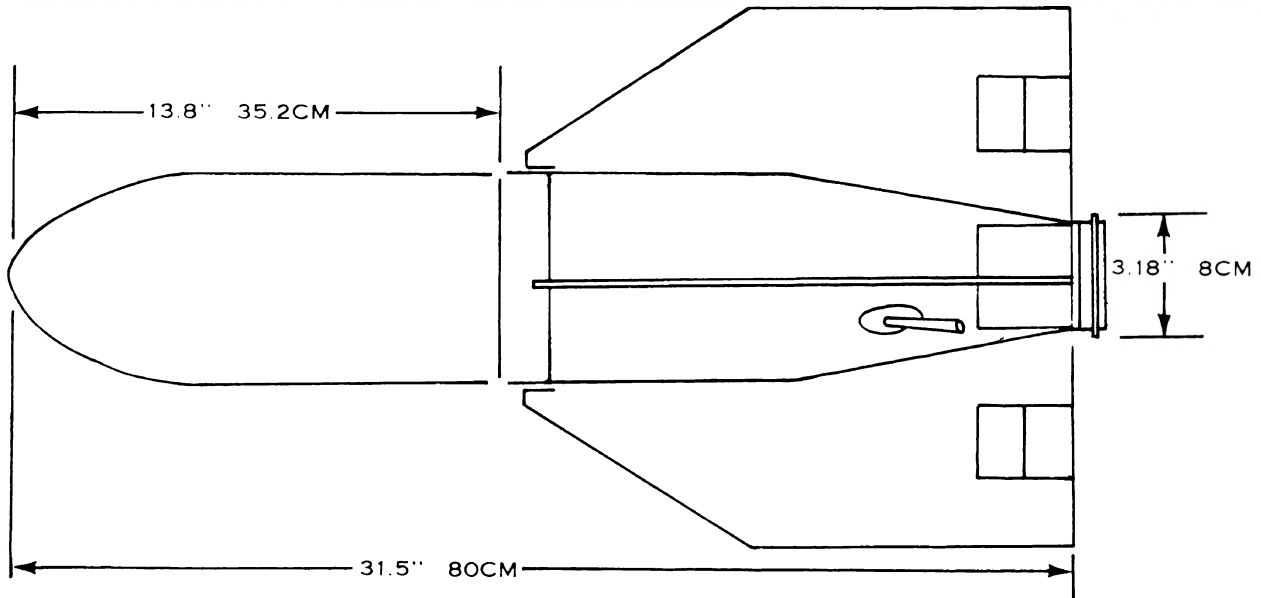

Figure 2. Dimensions of the ENTAC depicting the 130-mm warhead.

(7) *Battery charger.*

Weight..... 1.3 pounds, 1.6 kilograms.
Height..... 3.5 inches, 8.9 centimeters.
Width..... 3.5 inches, 8.9 centimeters.
Length..... 4.3 inches, 10.9 centimeters.

Note. A complete set of guidance equipment consists of one TR-10 guidance control unit, two selection boxes, three batteries, two 100-meter cables with reels and stands, ten 10-meter missile cables, one circuit test set, three battery chargers, and a battery charger cable assembly.

4. Guided Missile Flight Control Training Set (Simulator S-58)

a. General. The simulator is an electronic device, which is used for marksmanship training and for maintaining gunner proficiency after qualification. It incorporates a cathode

ray oscilloscope (similar to a television screen) on which is projected a small blue spot of light representing the flare of the missile. This spot of light is controlled with the guidance unit control stick.

b. Detailed Description.

(1) *Simulator.*

Weight 235 pounds 106.6 kilograms
Height 40.8 inches 103.6 centimeters
Width 20.0 inches 50.8 centimeters
Length 23.2 inches 58.9 centimeters

(2) *Storage cabinet.*

Weight 103 pounds 46.7 kilograms
Height 45.4 inches 113.3 centimeters
Width 24.5 inches 62.2 centimeters
Length 27.5 inches 69.8 centimeters

CHAPTER 2

MECHANICAL TRAINING

Section I. ASSEMBLY AND PREPARATION FOR FIRING

5. General

a. Mechanical training is designed to teach the soldier the following:

- (1) How to attach the warhead to the missile body.
- (2) How to prepare the missile for firing.
- (3) Principal components.
- (4) Missile functioning.
- (5) Functioning of the guidance equipment.
- (6) Operation and use of the S-58 Training Simulator.
- (7) Maintenance and storage.
- (8) Malfunctions and immediate action.

b. The individual soldier is not authorized to disassemble the missile, guidance equipment, or the S-58 Training Simulator. Repairs requiring disassembly will be accomplished at third or higher echelon.

6. Assembly of the Missile

a. *Removal of Missile From Its Shipping Container (fig. 3).*

- (1) Place the missile shipping container on its end with the removable cover up.
- (2) Lift the top handles up and force them out and down, thus freeing the four catches.
- (3) Release the catches and remove the cover.
- (4) Reach inside the shipping container

and grasp the inside of the launching container and lift out.

Caution: Do not pull on the missile body.

- (5) In the event you cannot lift the launching container, then lay the shipping container on its side and remove the launching container from a horizontal position. Once removed, place the launching container, with missile body, to one side.
- (6) Reach inside and raise the metal lid protecting the warhead.
- (7) Grasp warhead base cover and lift.
- (8) Grasp the underside of the warhead nose and remove the warhead from the shipping container.

Caution: Do not attempt to lift the warhead by the canvas strap.

b. *Attachment of the Warhead to the Finned Body (fig. 3).*

- (1) First, remove the protective cover from the base of the warhead.
- (2) Check the base of the warhead to insure it is not damaged.
- (3) Place the warhead in front of the finned body and aline the yellow marks on the warhead and missile body.
- (4) Press the warhead against the missile body until the warhead is seated and then turn it about one-sixth of a turn clockwise without forcing.
- (5) The missile, prepared as indicated above, is picked up by the carrying strap atop the launching container. (One man can carry two missiles.)

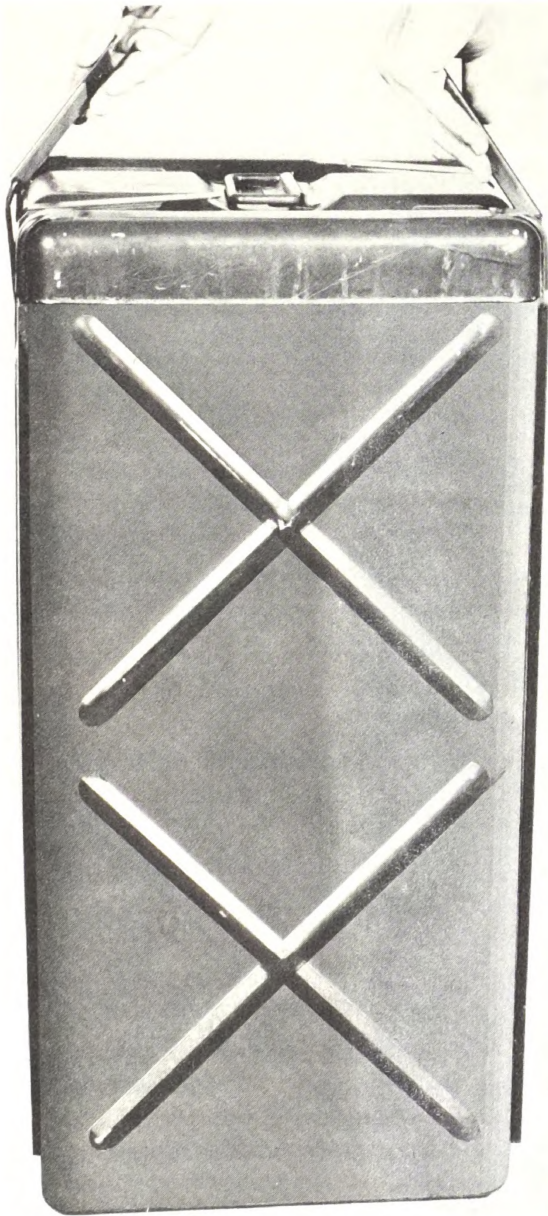

STEP 1. PLACE CONTAINER ON END WITH COVER UP AND FORCE HANDLE OUT AND DOWN.

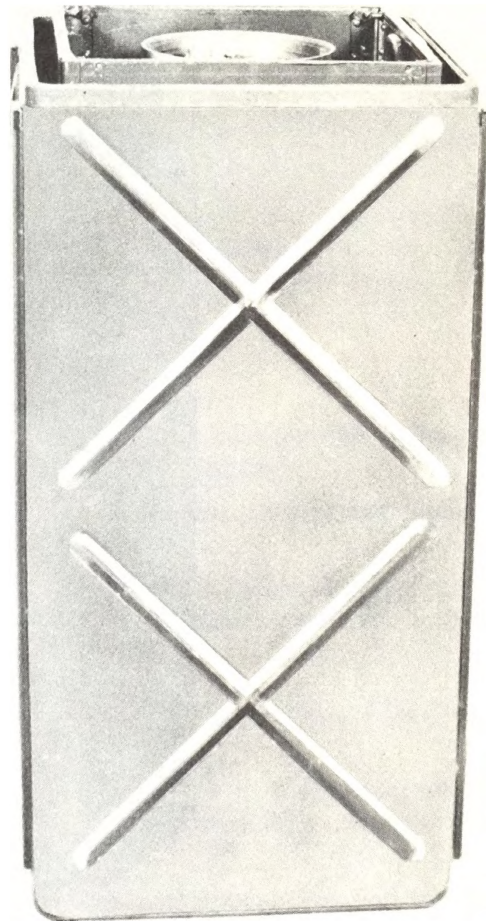
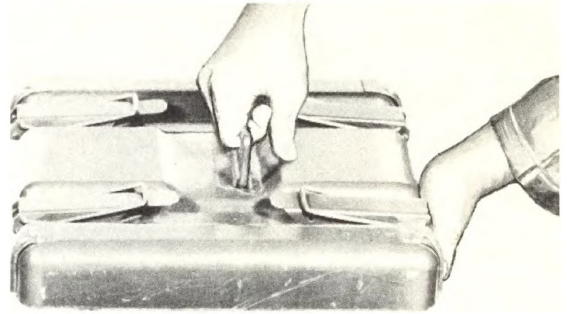

STEP 2. REMOVE COVER

Figure 3. Removal of missile from containers and assembly.

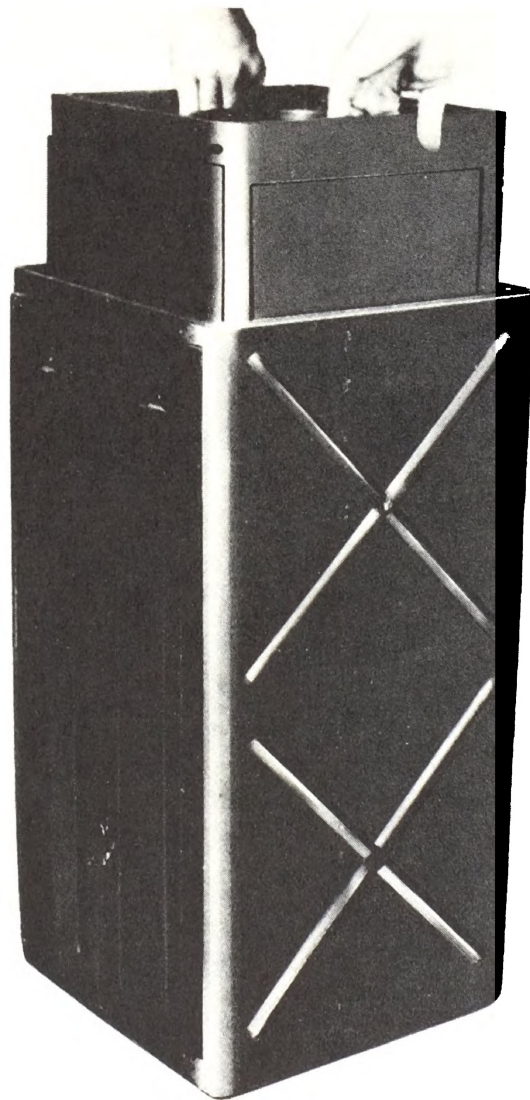

STEP 3. GRASP INSIDE RIDGE OF THE LAUNCHING CONTAINER AND REMOVE. DO NOT PULL ON MISSILE BODY.

Figure 3.—Continued.

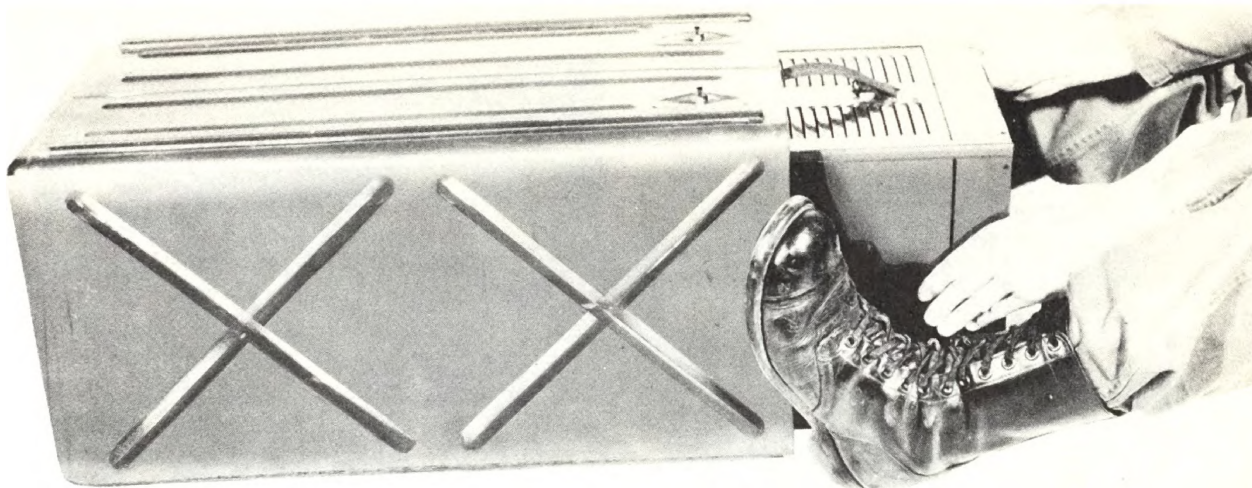

STEP 4. OR LAY SHIPPING CONTAINER DOWN TO REMOVE LAUNCHING CONTAINER.

Figure 3—Continued.

7. Preparation for Launching

a. Normal Ground Conditions (1, fig. 4).

- (1) Unlatch the ramp by sliding the holding latch toward the rear of the launching container.
- (2) Remove the two anchoring pins that are secured beneath the ramp by two spring clamps.
- (3) Fold out the ramp and place the missile on its preselected position. The weight should rest on the rear edge of the launching container and the forward rim of the ramp.
- (4) Orient the missile to the desired launching azimuth.
- (5) Insure that the yellow rocket symbol on the launching container is aligned with the target.
- (6) Check to insure that the launching container is stable by firmly pushing

it to the rear on the front, top edge of the container.

Caution: Do not exert pressure on the ramp.

- (7) Drive the anchoring pins through the two outside ramp holes and into the ground.

b. Soft Ground Conditions (Sand or Snow) (2, fig. 4).

- (1) Proceed with the emplacement up to, but not including, driving anchoring pins.
- (2) Extract the anchor rod by pulling it out of the launching container. (The handle is visible under the top side of the launching container.) Two straight rods will be simultaneously extracted along with the anchor rod.
- (3) Drive the two straight rods into ground through the holes at either side of the ramp. Drive the anchor rod



STEP 5. RAISE LID PROTECTING WARHEAD

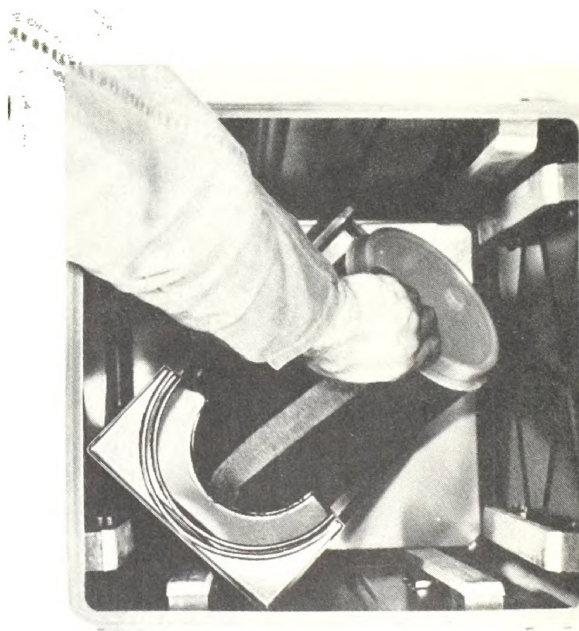

STEP 6. GRASP WARHEAD BASE COVER AND LIFT.

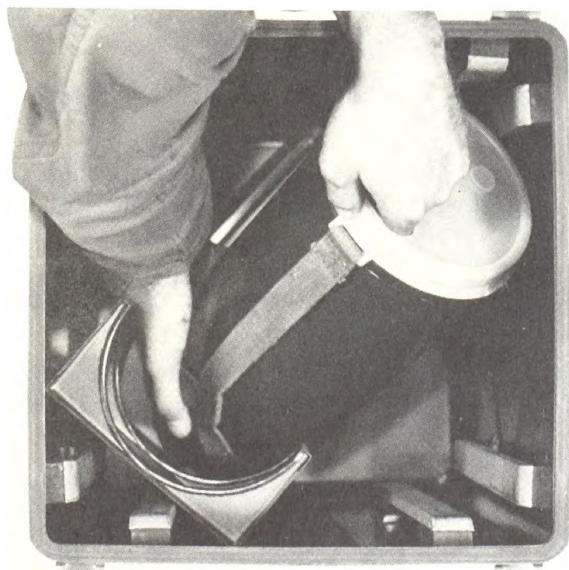

STEP 7. GRASP WARHEAD NOSE AND REMOVE

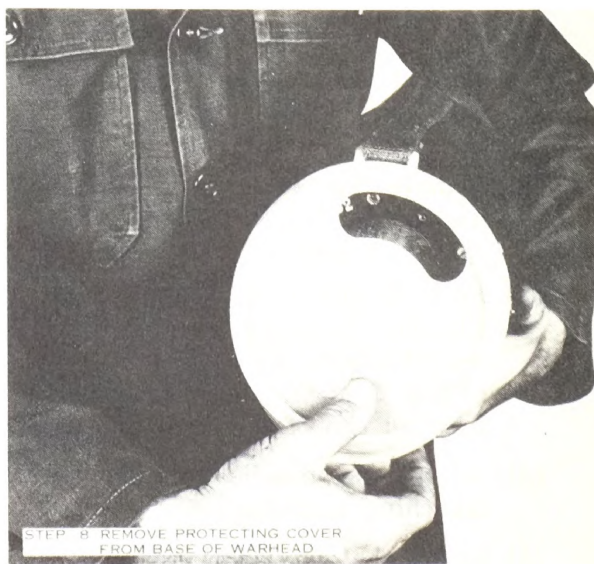

STEP 8. REMOVE PROTECTING COVER FROM BASE OF WARHEAD

Figure 3—Continued.

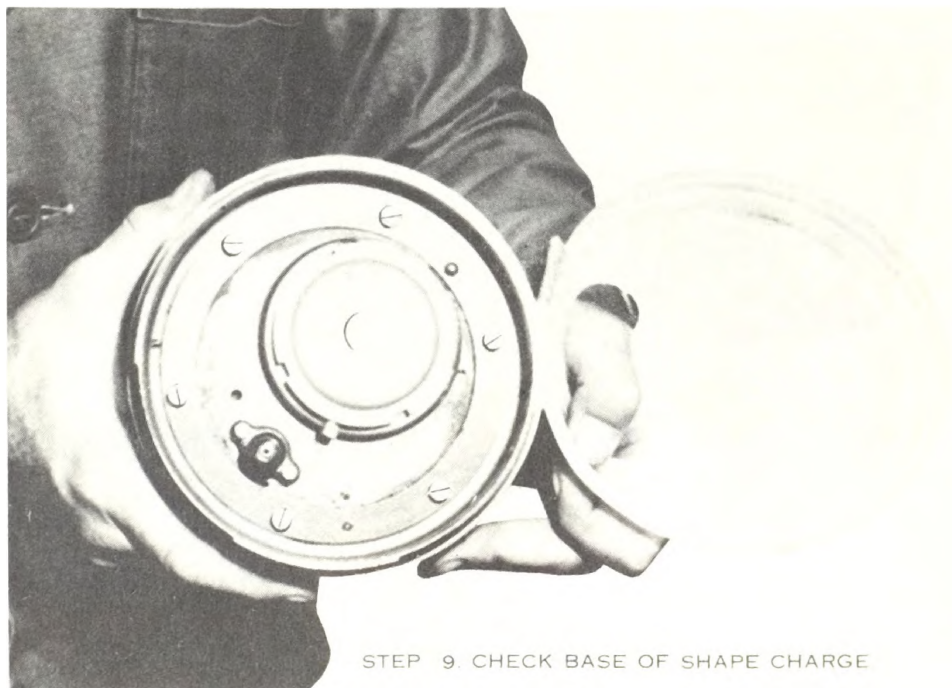

STEP 9. CHECK BASE OF SHAPE CHARGE

Figure 3—Continued.

into the ground through the center hole of the ramp. At the completion of anchoring, the rods should protrude not more than $1\frac{1}{2}$ inches above the ground.

c. Hard Ground Conditions (Frozen, Clay, or Soft Stone) (3, fig. 4).

- (1) Unfold the ramp as previously outlined.
- (2) Extract the anchor rod and straight rods.

- (3) Insert the straight rods in the angled, recessed holes provided under the bottom, front corners of the launching container.
- (4) Insert the anchor rod in the left hole of the two holes provided in the center rear of the bottom, inside edge of the launching container, with the large hook down.
- (5) Insure that the anchor rod is properly seated and that the split end has engaged the guide pin inside the hole.

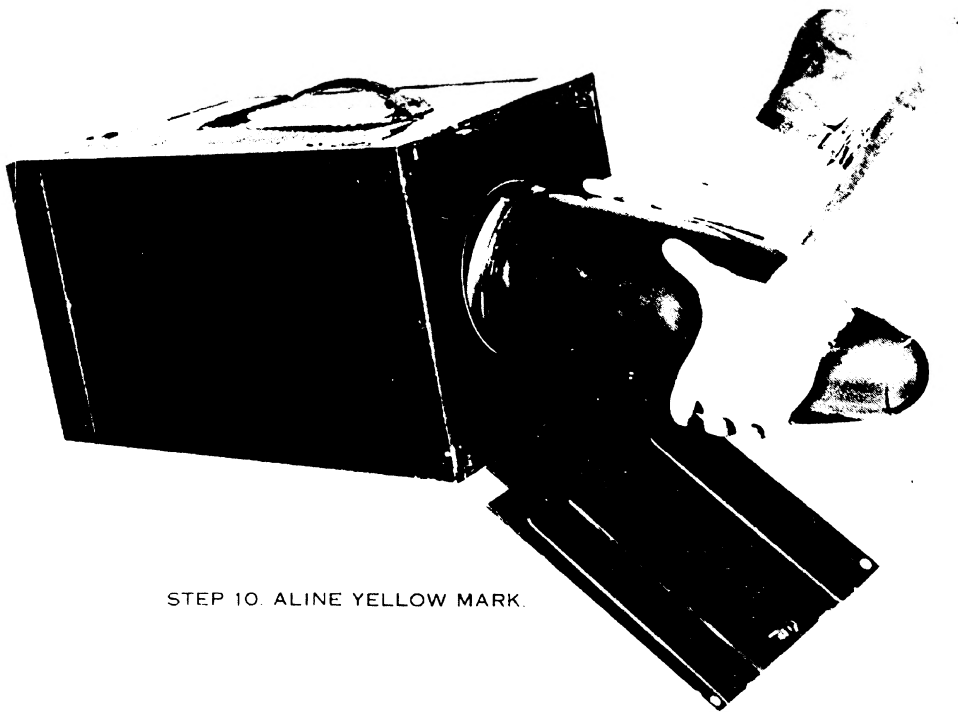

STEP 10. ALINE YELLOW MARK.

Figure 3—Continued.

- (6) Firing under these conditions might cause the launching container to slide from three to nine meters to the rear. Therefore, it is best to provide sufficient slack in the missile cable to allow for this sliding movement. The stability of the launching container will be proportional to the ease of its sliding without encountering obstacles in its slide path.

d. Mask Clearance. To insure mask clearance, the missile is oriented towards the target. By sighting through the launching container along the axis of the missile, determination can be made if mask clearance has been obtained. If

not, find a better launching site in the immediate vicinity, or increase the angle of the launching container until mask clearance is obtained. *Insure that the launching container is securely anchored.*

e. Desired Elevation.

- (1) It will be found that different elevations will be possible, depending on the hole used and the manner in which the anchor rod handle is turned in conjunction with the ramp or straight rods.
- (2) The normal angle of launch (elevation) is between 11 and 15 degrees.

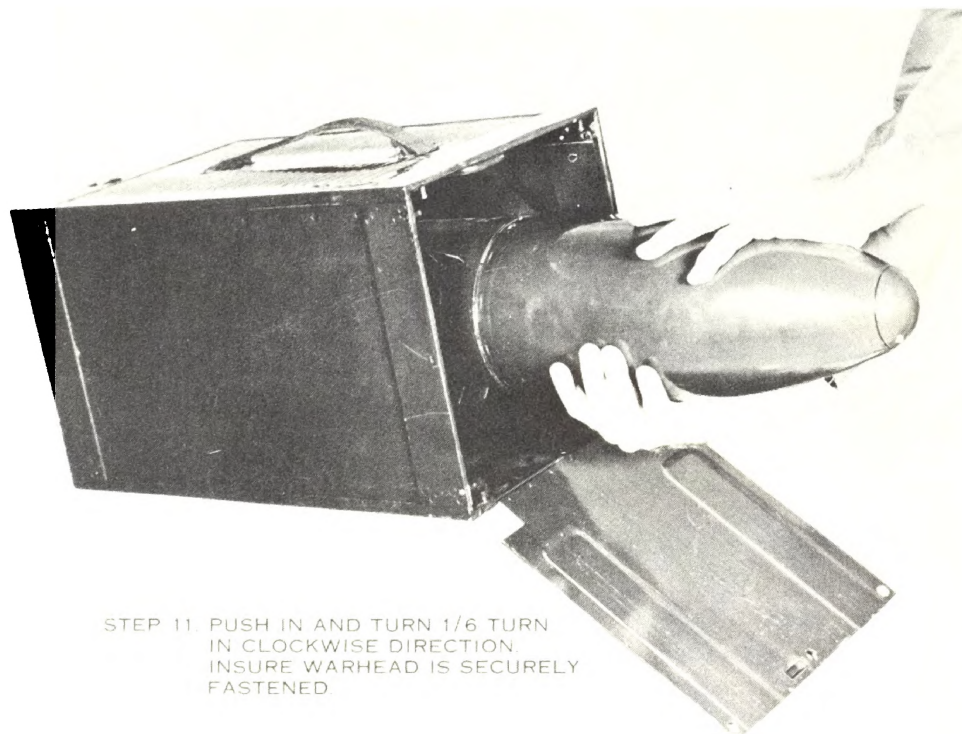

STEP 11. PUSH IN AND TURN 1/6 TURN
IN CLOCKWISE DIRECTION.
INSURE WARHEAD IS SECURELY
FASTENED.

Figure 3—Continued.

(3) The approximate degrees of elevation that may be obtained and the manner

in which they can be set, is outlined below:

<i>Method of Elevation</i>	<i>Degrees</i>
Ramp only	14
Ramp, use anchor rod in left hole with small hook down	11
Ramp, use anchor rod in left hole with large hook down	9
Ramp, use anchor rod in right hole with small hook down	7
Rods only	15
Rods, use anchor rod in left hole with small hook down	11
Rods, use anchor rod in left hole with large hook down	9
Rods, use anchor rod in right hole with small hook down	6

Caution: The launching container must be securely anchored to prevent the container from flipping and severing the guidance wires. If the anchoring rods are used (as in *c* above) the launching ramp must still be used to prevent the exhaust gases from blowing under and flipping the launching container.

Note. In case of strong tail winds, launch the missile with maximum elevation (14–15 degrees). When firing on a very close target (400 meters), launch the missile at an elevation of approximately 6 degrees. Elevations of less than 6 degrees are *not* recommended, due to missile's flight characteristics.

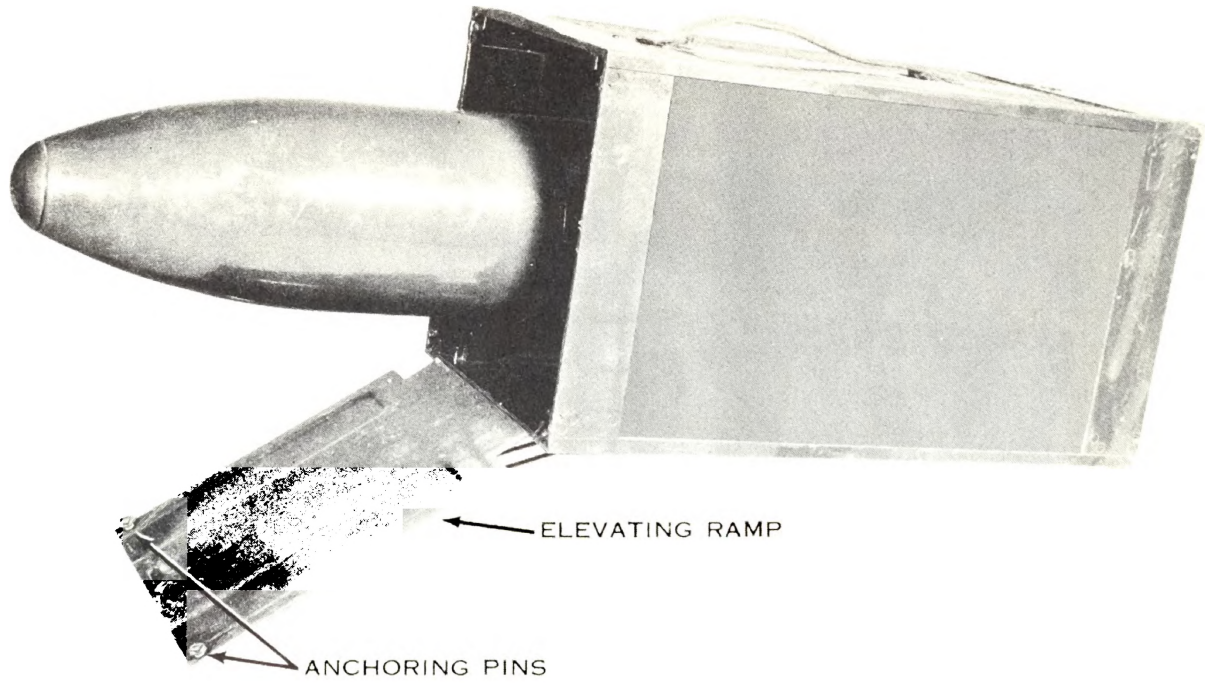

1 Normal ground conditions

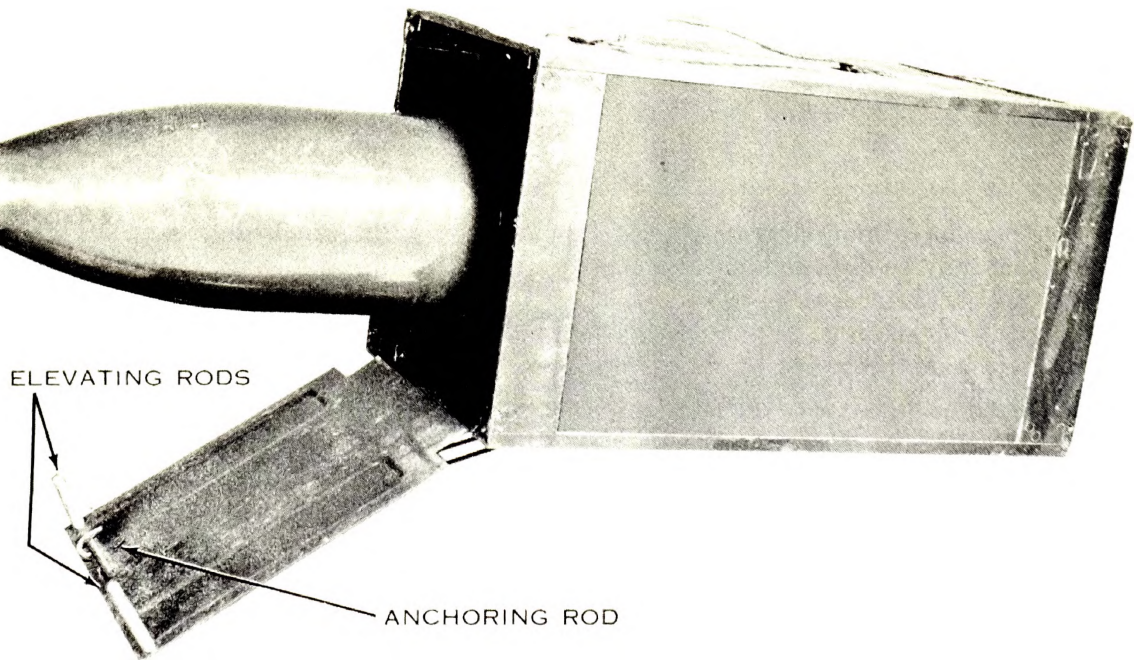

2 Soft ground conditions

Figure 4. Preparations for launching.

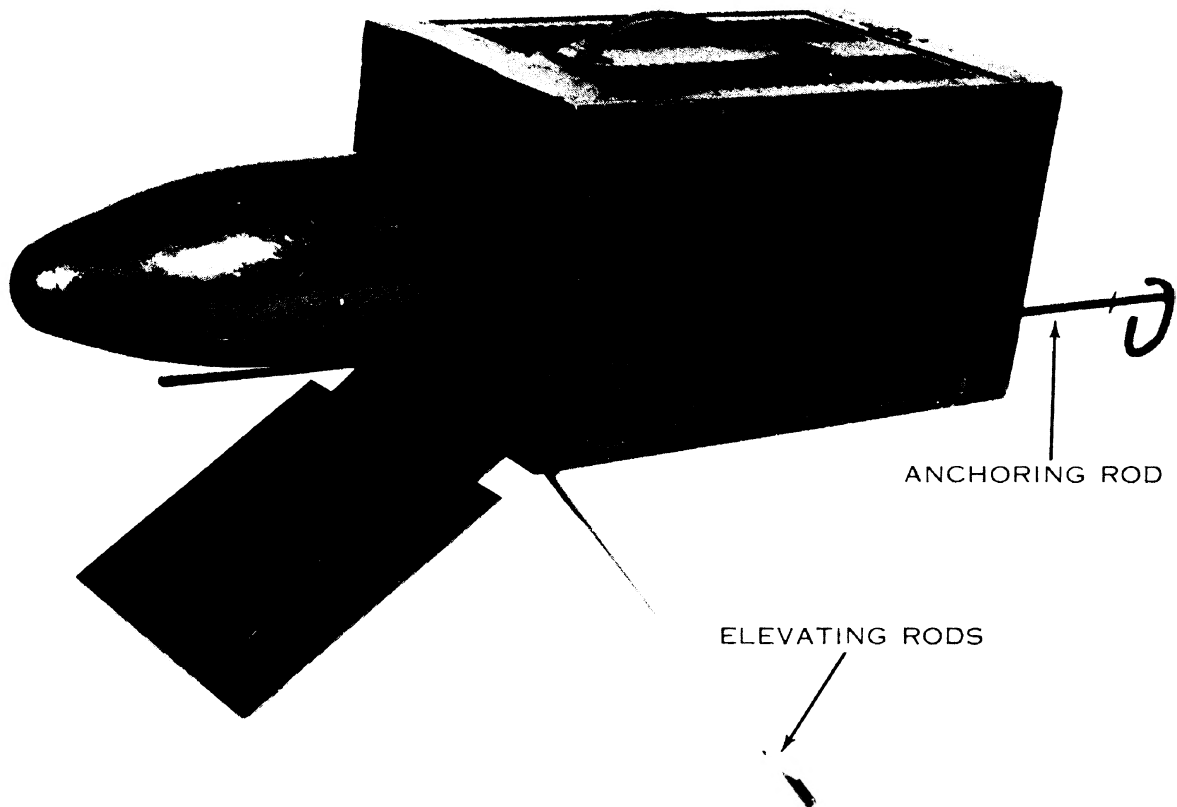

3 Hard or frozen ground

Figure 4—Continued.

Section II. PRINCIPAL COMPONENTS AND FUNCTIONS

8. Missile Components

The ENTAC consists of two major components: the finned body and the warhead (fig. 5).

a. The finned body is a tubular magnesium casing into which the following components are fitted:

- (1) Booster motor.
- (2) Sustainer motor.
- (3) Gyroscope.
- (4) Guidance wire bobbin assembly.
- (5) Pyrotechnic flare.
- (6) Fuze assembly.
- (7) Missile battery.

- (8) Spoilers.
- (9) Wings.
- (10) Warhead.
- (11) Relays and rectifiers.

b. The warhead consists of a light metal alloy ogive housing the following components:

- (1) A nose switch.
- (2) A male electrical contact.
- (3) A movable plate.
- (4) One of the two warheads described below:
 - (a) *Inert.* The inert warhead contains a machined steel block that compensates for the difference in

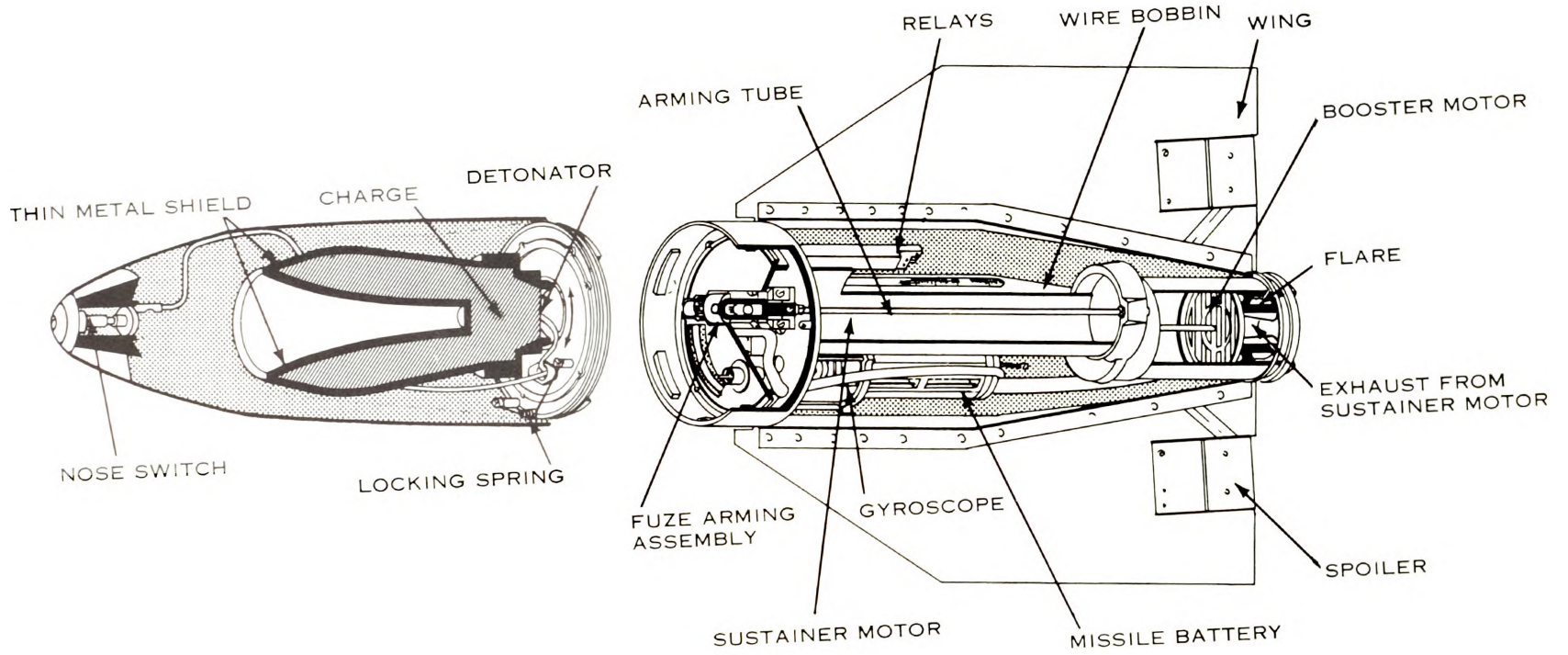

Figure 5. Cutaway drawing of the ENTAC.

weight due to the lack of the shape charge. Ogive configuration is the same as the 130-mm HEAT.

Note. This warhead is to be used with missile Federal stock number (FSN) 1410-855-9706 only.

- (b) *130-mm HEAT.* The shape charge will penetrate in excess of 20 inches of homogeneous steel. The ogive configuration is shown in figure 5. This warhead is ineffective against personnel.

Note. This warhead is to be used with missile FSN 1410-855-9707 only.

9. Missile Functioning

a. General. Functioning may be divided into five phases.

- (1) Activation of the missile battery.
- (2) Activation and operation of the propulsion system.
- (3) Activation and operation of the gyroscope assembly.
- (4) Arming and firing of the warhead.
- (5) The electrical guidance system.

b. Activation of the Missile Battery (fig. 6). The missile battery is activated when the gunner compresses the firing switch. The battery electrolyte (acid) is stored externally on the launching container in a separate housing (battery activator). The missile battery is charged by the electrolyte when the gunner compresses the firing switch. This battery is the source of power to ignite the booster and flare squibs, to operate the spoilers, to transmit guidance signals to and through the relays, and to detonate the warhead. The battery maintains power for approximately 40 seconds after activation.

c. Activation and Operation of the Propulsion System.

- (1) The missile is propelled by a two-stage solid propellant rocket motor. The booster, or first stage, is ignited by an electrical impulse which sets off a black powder charge in the motor. This electrical impulse comes from the missile battery. The booster motor applies a 30-G acceleration which

brings the missile to its flying speed in one-third of a second. The booster contains eight sticks of extruded double end grain.

- (2) The sustainer, or second stage, is ignited by a powder train located in the venturi of the sustainer exhaust. The heat from the booster motor ignites the powder train. This is accomplished almost instantaneously with the ignition of the booster motor. The propellant in the sustainer motor completely fills the chamber and is a slower burning cast, double end grain. Total burning time of this motor is approximately 25 seconds, varying slightly with the temperature.

d. Activation and Operation of the Gyroscope Assembly (fig. 7)

- (1) The gyroscope is activated by means of a wire which is wound around the gyro rotor and extends through the missile body. It is anchored to the launching container. When the missile is launched the wire imparts spin to the gyroscope and brings it to approximately 18,000 revolutions per minute.
- (2) The wire passes through a fitting mounted on the primary gimbal and a hole in the secondary gimbal. This effectively cages the gyro until the wire is pulled out and the rotor is up to speed.
- (3) The purpose of the gyroscope is to keep the missile in a "no roll" attitude. This is accomplished by a mobile switch affixed to the gyroscope's main axis and two electrical contacts as shown in figure 7. When the missile is flying in its proper attitude, both electrical contacts, "ED" and "EI," are open. As the missile attempts to rotate, one of the electrical contacts is closed. This creates a command that overrides any command being received by the missile and will cause corrective action to be taken by the spoilers on the vertical wings, thus righting the missile to its proper attitude. (See

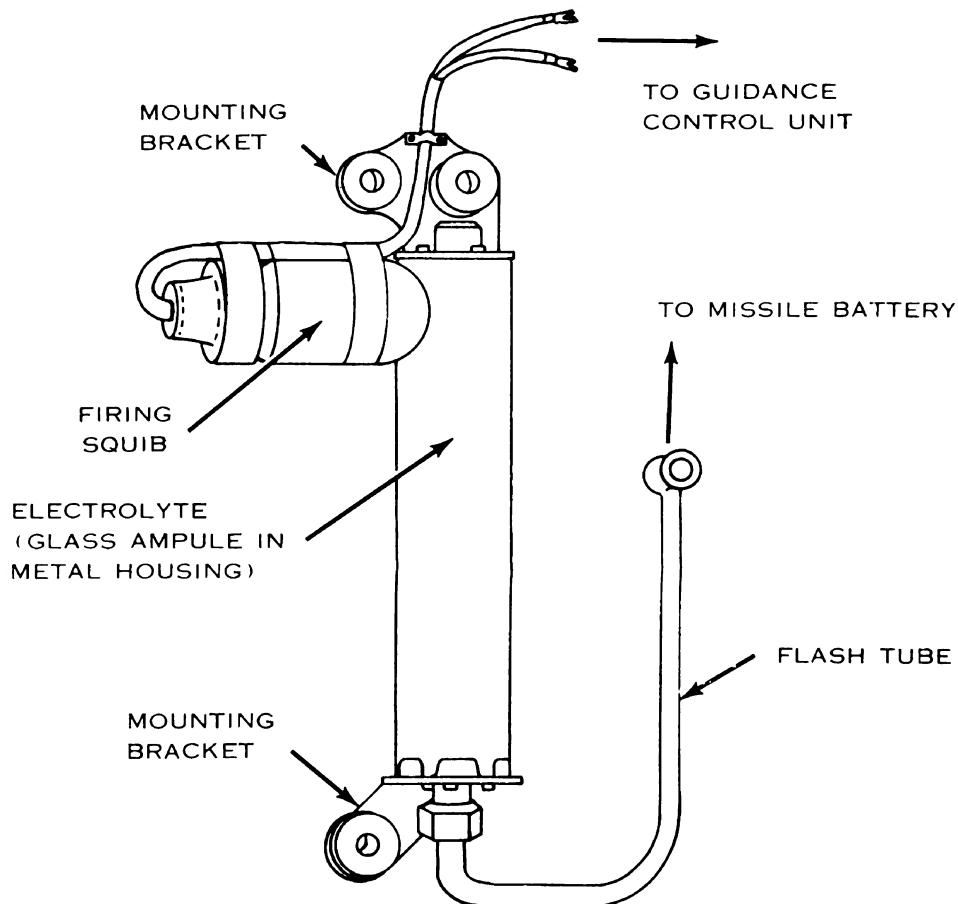

Figure 6. Battery activator.

TM 9-1400-455-35 for further discussion.)

e. Arming and Firing of the Warhead.

- (1) The missile battery, when activated, is the source of power for detonating the warhead.
- (2) The missile fuze arming assembly is activated by gas pressure from the sustainer motor. Gases from the sustainer motor move forward through the arming tube located on the left

side of the sustainer motor, forcing a piston to shear a safety pin and connect the arming assembly (fig. 8). This piston movement completes the electrical circuit in the fuze assembly. After arming, the circuit is completed to the nose switch in the warhead (fig. 8). The time required for the entire arming operation is approximately three to four seconds, at which time the missile has traveled some 240 to 320 meters from launch.

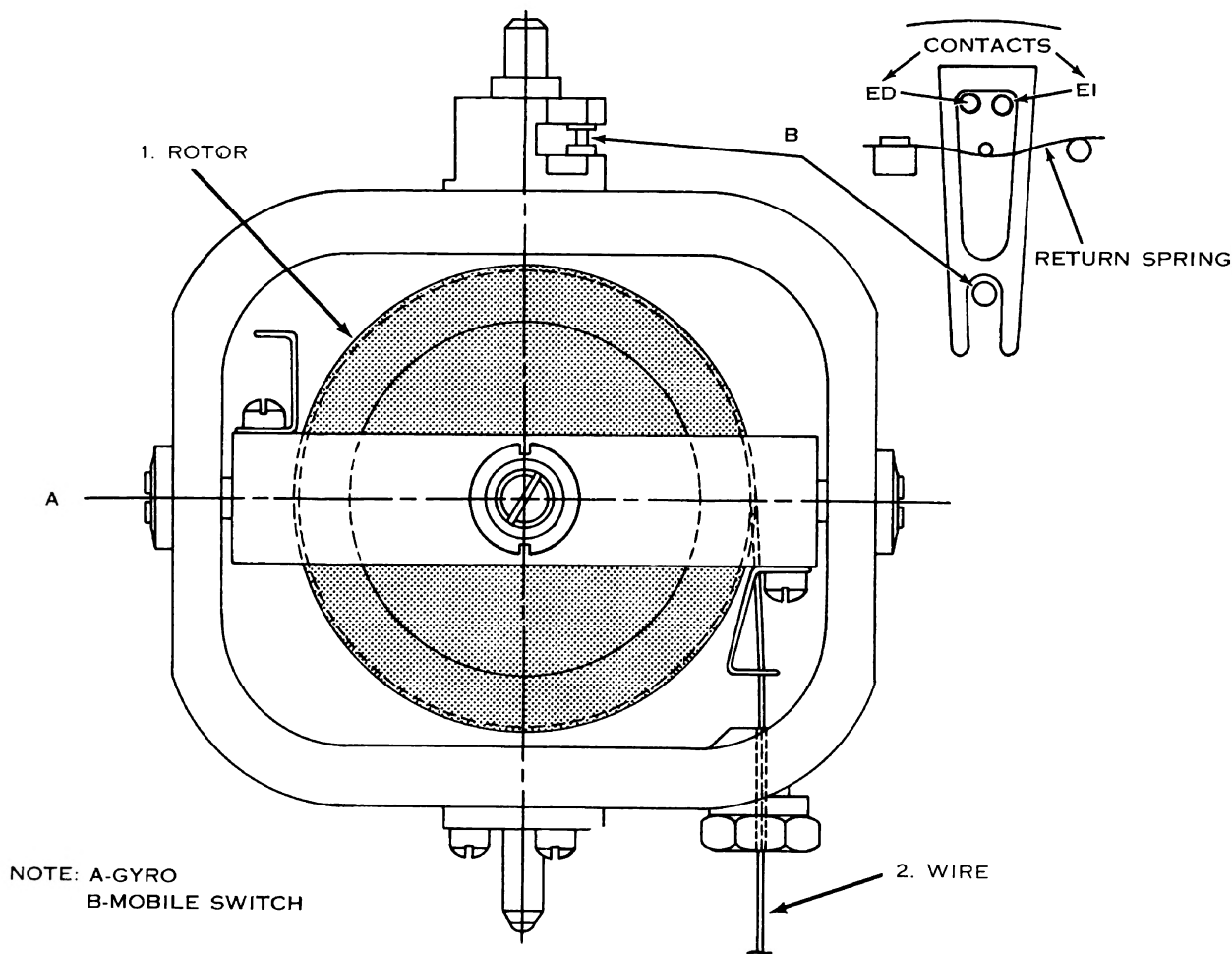

Figure 7. Activation and operation of the gyroscope assembly, a diagram.

(3) Detonation of the warhead is caused when the nose switch is closed. This switch is located in the nose of the missile. The closing of this circuit sends an electrical impulse to the detonator at the base of the shape charge, and the warhead explodes.

f. The Electrical Guidance System.

- (1) As soon as the missile battery is activated, the spoilers begin oscillating at eight cycles per second.
- (2) The signals from the guidance station are transmitted to the missile over two glazed, steel wires which unwind from within the missile. The standing ends are attached to junction boxes in the launching container. A relay circuit interprets these signals for

pitch (up and down movement) and yaw (right and left movement) on the basis of amplitude and polarity, respectively, directing them to the proper spoiler.

- (3) In the center of each spoiler housing is a slot which affords a passage for the spoiler frame. The spoiler frame is a thin aluminum blade with a cut-away center. At each end of the cut-away center there is a small slot which is fitted over a thin metal plate, which in turn is affixed to the rear of the spoiler housing by a small pin. On either side of the metal plate is a magnetically opposed solenoid (electro-magnet, fig. 9) which, upon receiving signals, will cause the metal plate to move from one solenoid to the

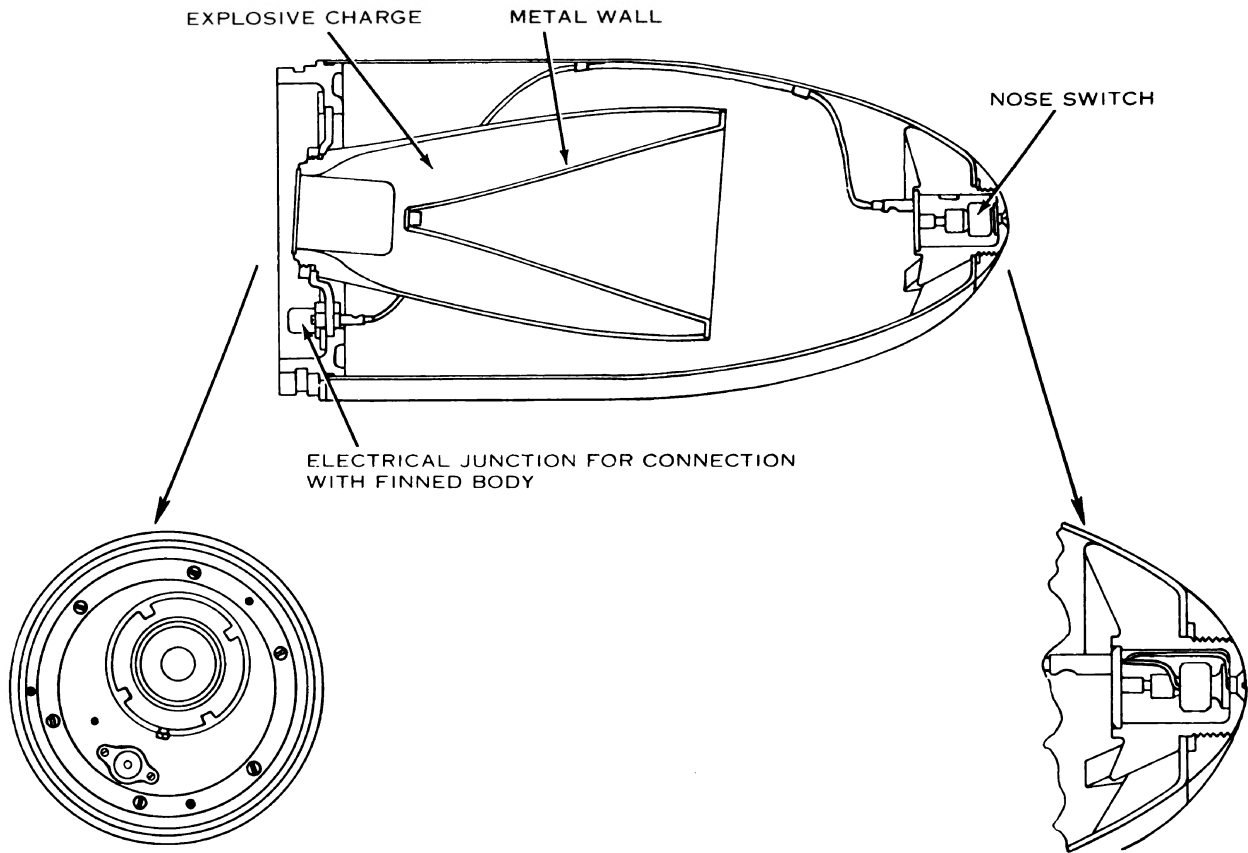

Figure 8. Diagram of warhead with detailed diagrams of the nose switch and base.

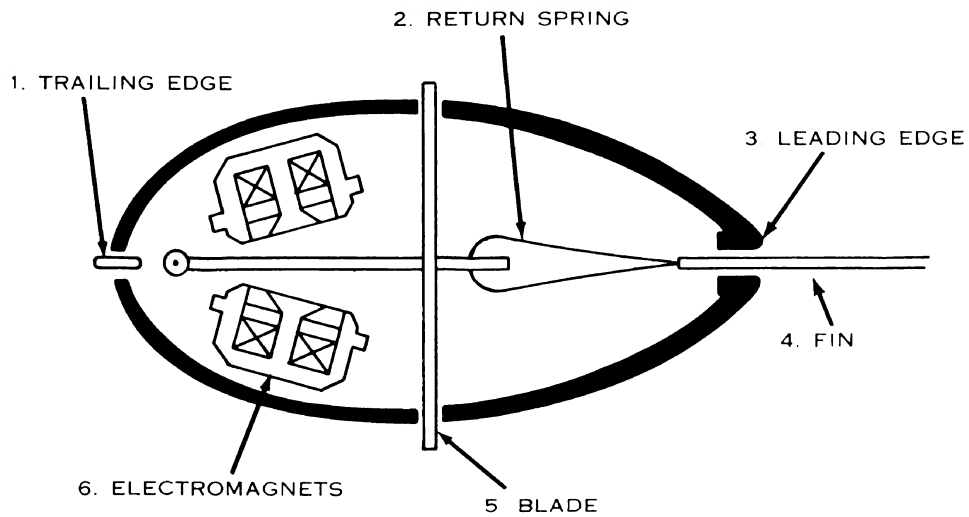
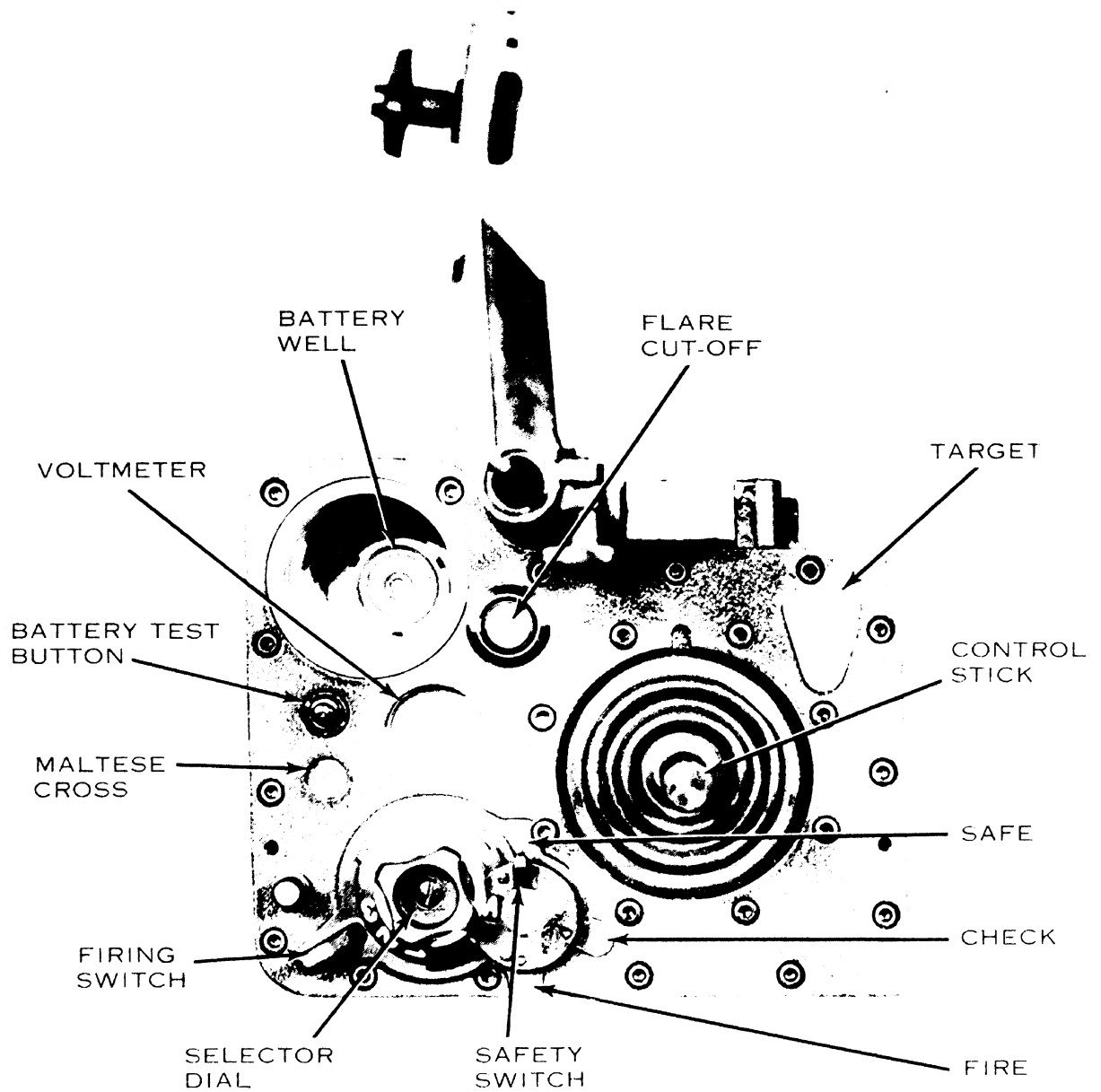

Figure 9. Diagram of spoiler assembly.



TOP VIEW
 (WITH BATTERY AND BINOCULARS REMOVED)

Figure 10. Guidance control unit.

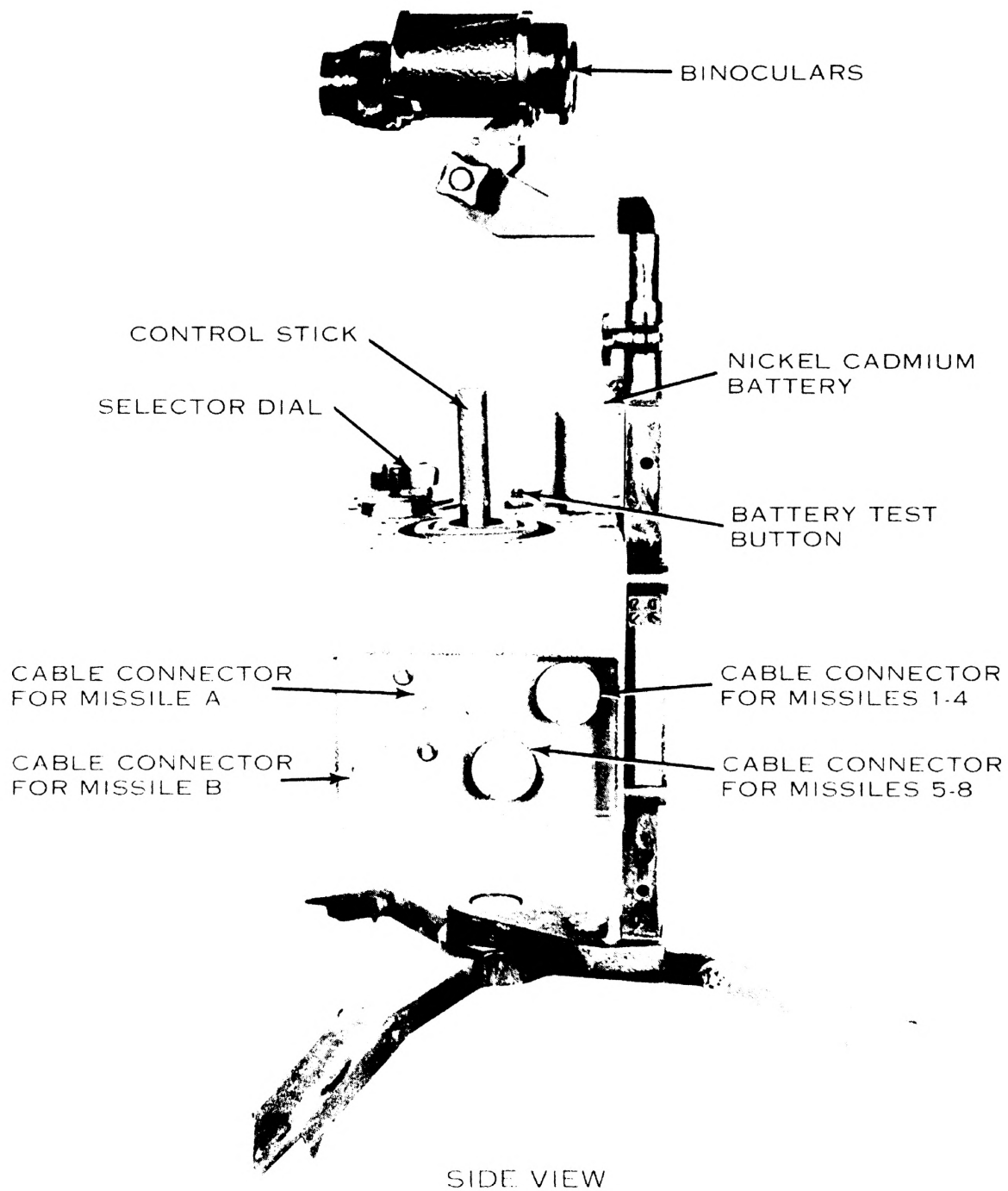
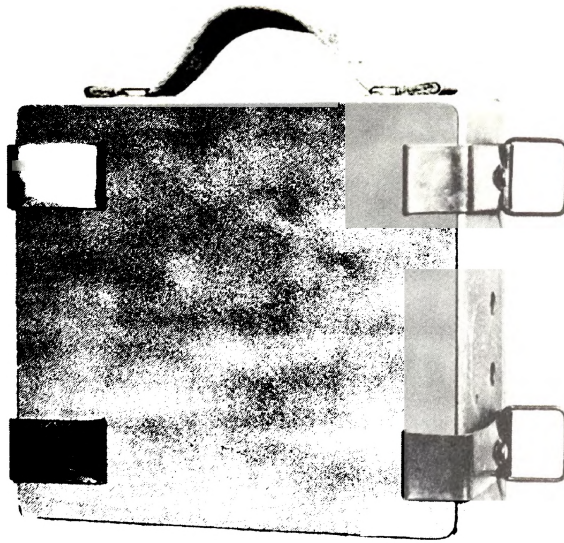

Figure 10.—Continued.



1 Closed

Figure 11. Selection box.

other. This in turn causes the spoiler frame to move or oscillate. In the forward portion of the spoiler housing is a readjusting spring that returns the spoiler frame to the neutral position between signals.

- (4) The oscillation rate of the spoiler frame remains constant until it receives guidance signals. A change in direction or elevation is effected by varying the length of time the spoiler frame remains at either end of each oscillation, "spoiling" the airflow and

causing drag, thereby causing the missile to change directions.

10. Guidance Control Unit

a. The guidance control unit consists of a light, cast metal alloy box mounted on an adjustable tripod with a pair of 8 x 30 binoculars (fig. 10). These binoculars are of special design and are the only type that can be affixed to the tripod. The box itself houses the following components:

- (1) Control stick.
- (2) Missile selector dial.

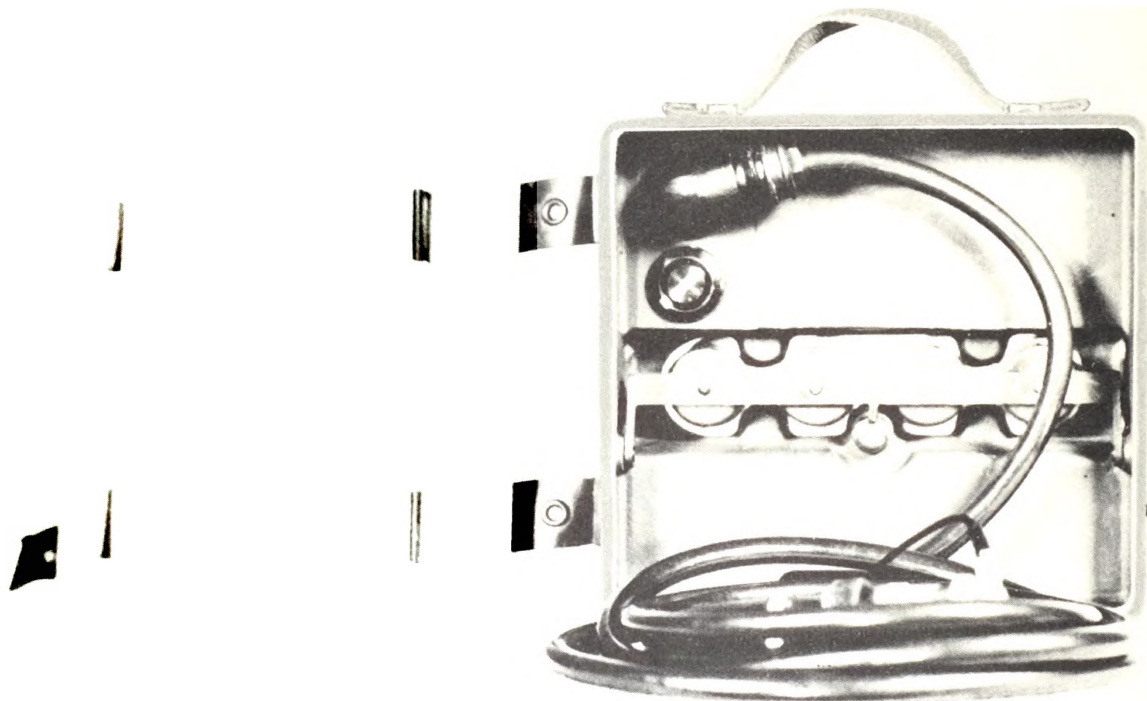

2 Open with connectors covered

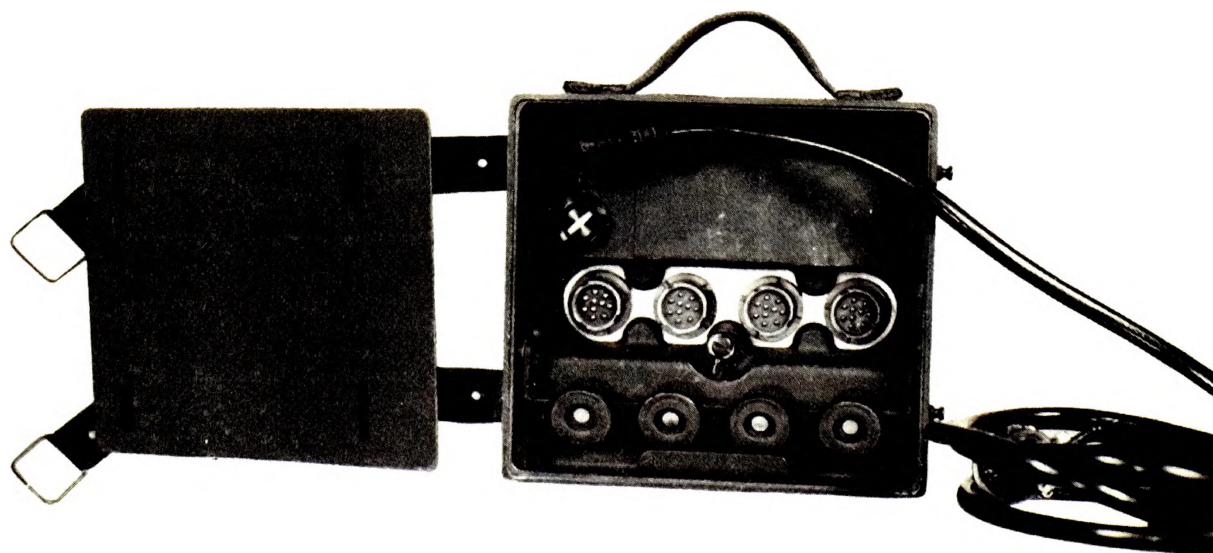

3 Open with connectors exposed

Figure 11—Continued.

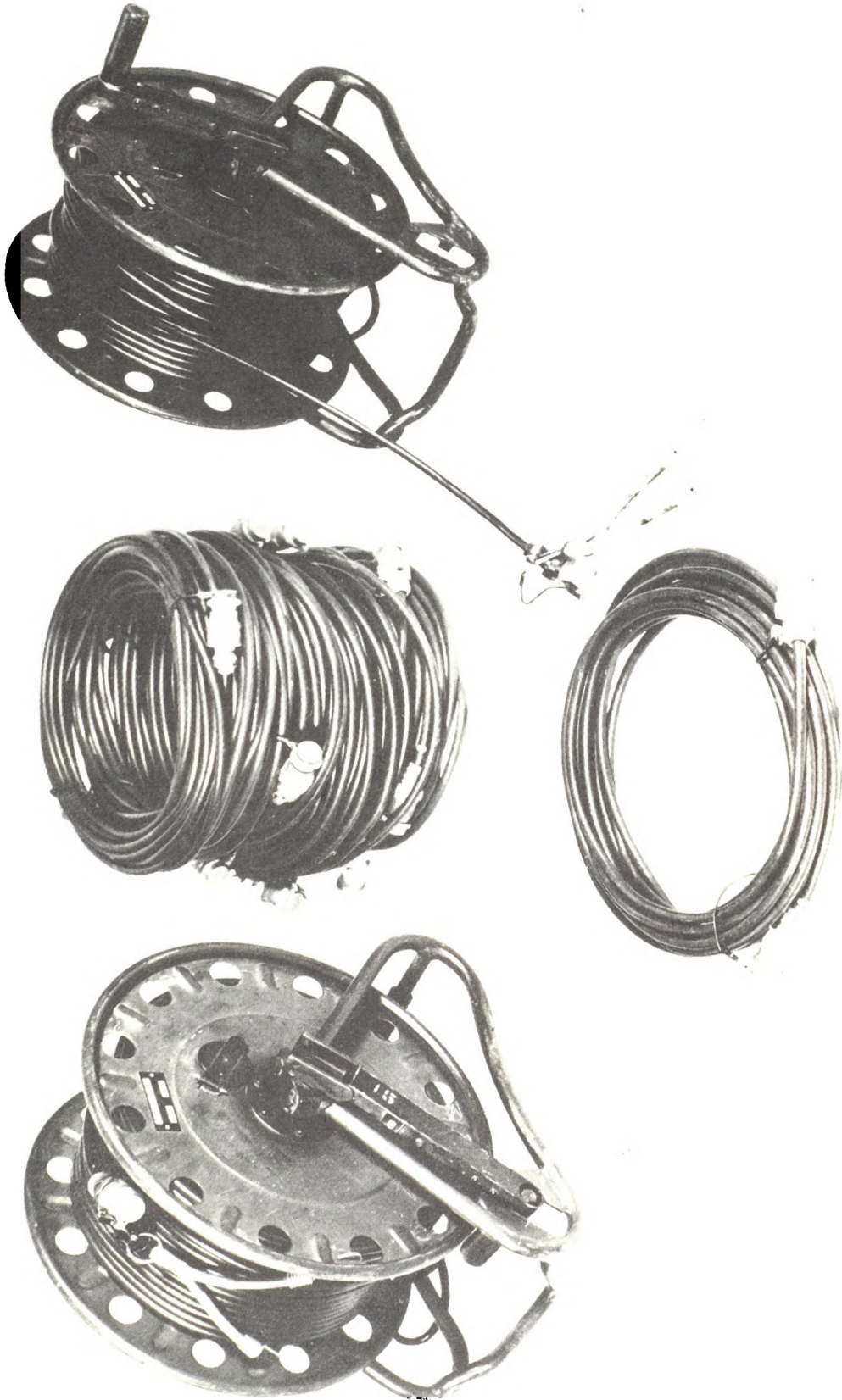

MISSILE CABLE

Figure 12. Cables and reel assembly.

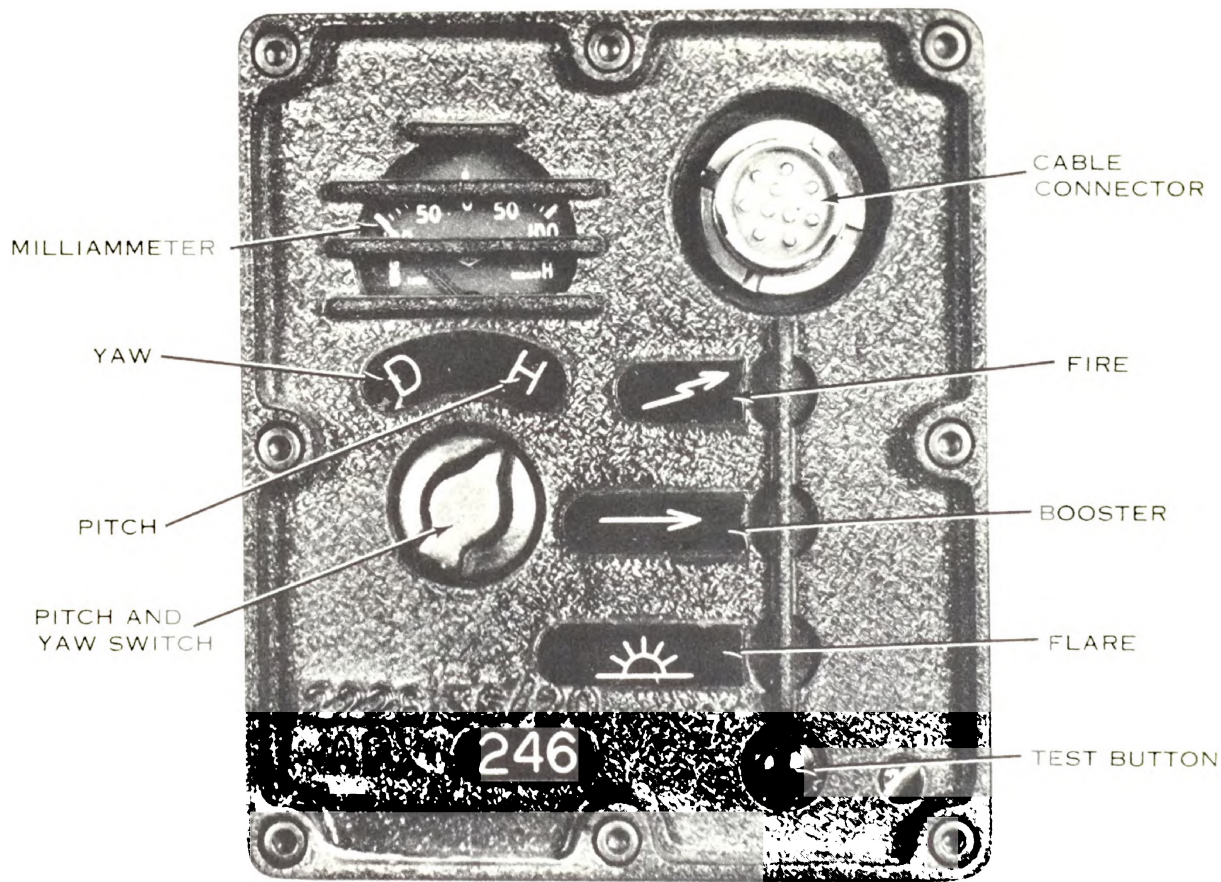

Figure 13. Circuit test set.

- (3) Firing switch.
- (4) Safety switch.
- (5) Maltese cross indicator.
- (6) Battery test button.
- (7) Voltmeter.
- (8) Nickel cadmium battery.
- (9) Flare cutoff switch.
- (10) Target orientation arrow.
- (11) Cable connections.

b. The inner components are transistorized to generate and transmit the electrical guidance signals to the missile.

c. The gunner guides the missile by means of the control stick. Movements are converted into pitch and yaw signals by two potentiometers (variable resistors) connected to the stick within the guidance unit. The control stick is

mounted vertically and is oriented so that a backward or forward movement directs the missile up or down. A left or right movement directs the missile accordingly. Combination commands can also be made.

d. The missile selector dial is used by the gunner to select the missile that he desires to fire. The dial has letters A and B and numbers 1 through 8. The missile to be fired must be selected so that the letter or number on the dial appears in the slotted portion on the right side of the selector dial. A color coding on the selector dial corresponds with the color coding of the missile cable connections on the side of the guidance station and selection box. A total of 10 missiles can be prepositioned, connected, selected, and individually fired.

e. A squeeze-type firing switch enables the gunner to fire the missile selected. This is accomplished by using the left thumb and fore-



Figure 13.—Continued.



1 With battery, showing male socket

Figure 14. Battery charger.

finger and compressing the firing switch towards the fixed post. Once fully compressed, the firing switch is released.

f. The three-position safety switch on the guidance station has a safe position "S," a check position "C," and a firing position "T."

- (1) When the safety switch is placed in the "S" position, the squeeze-type firing switch is locked and cannot be compressed.
- (2) When the safety switch is rotated to the "C" position, the maltese cross indicator will flutter if a live missile or test set is connected to the guidance unit on the selected missile setting. The firing switch cannot be compressed when the safety switch is in the "C" position.
- (3) After rotating the safety switch to the "T" (fire) position, the lock on the firing switch is released and the firing switch can then be compressed;

however, the selector dial will be restricted to one of the three positions, "A-B," "1-4," "5-8," depending on the missile being fired.

g. The nickel cadmium battery in the guidance unit is tested, when inserted, by depressing the test button, making sure that the reading on the voltmeter is between 11 and 13.5 volts. If this desired reading is not obtained, change the battery and retest. The battery has a firing life of approximately two hours, and should always be on the battery charger when not in use. There are three batteries organic to each set of equipment.

h. By means of a flare cutoff switch located on the guidance unit, the gunner may fire the missile connected to the A and B cable connections with or without the flare ignited. White line to white line indicates the flare will ignite. To cut off the flare, depress the switch and turn one-quarter turn in either direction.

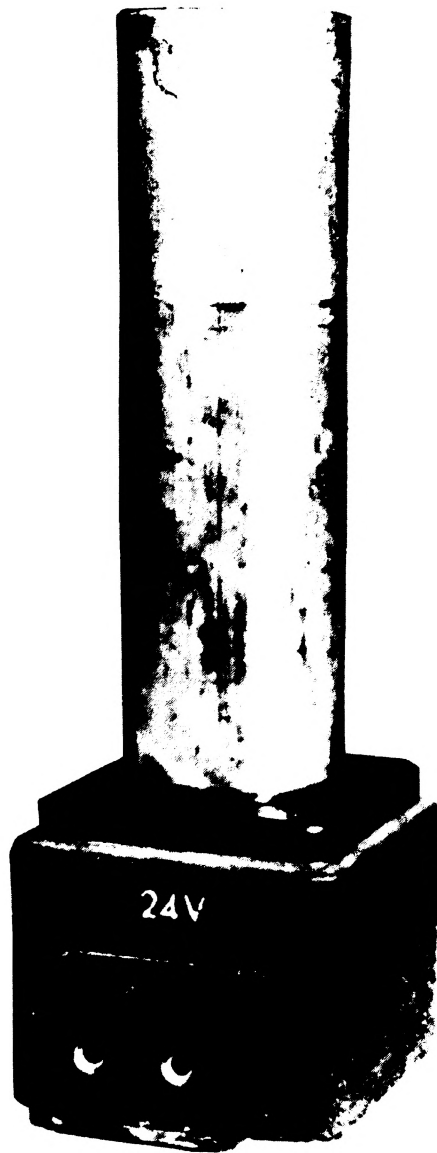

2 Reversed position showing female socket with battery inserted

Figure 14—Continued.

ELEVATING AND ANCHORING RODS ARE
CARRIED INSIDE LAUNCHING CONTAINER



1 Side view

Figure 15. Launching container.

i. The guidance unit is positioned so that the orientation arrow is pointing in the general direction of fire. Misalignment of the guidance unit will cause the gunner to improperly sense corrective commands to the missile and result in an erratic flight, or loss of missile control. This prevents the guidance unit from being reversed and assures that correct commands will be sent to the missile at all times.

j. On the right side of the guidance unit are four cable connections which allow the simultaneous connection of ten missiles, through various cable combinations. The two connections in the white or light painted area are

lettered A and B, to which two ten-meter missile cables are connected. This combination is the light method of launch. The two connections in the black painted area are numbered $\frac{1}{4}$ and $\frac{5}{8}$ and permit the attachment of two 100-meter cables. This allows a maximum of eight missiles to the offset over 100 meters from the guidance unit.

k. The signal generator (within the guidance unit) receives and transmits the pitch and yaw commands from the potentiometers. Changes in polarity cause changes in the missile's yaw movements; changes in amplitude cause changes in the missile's pitch movements.

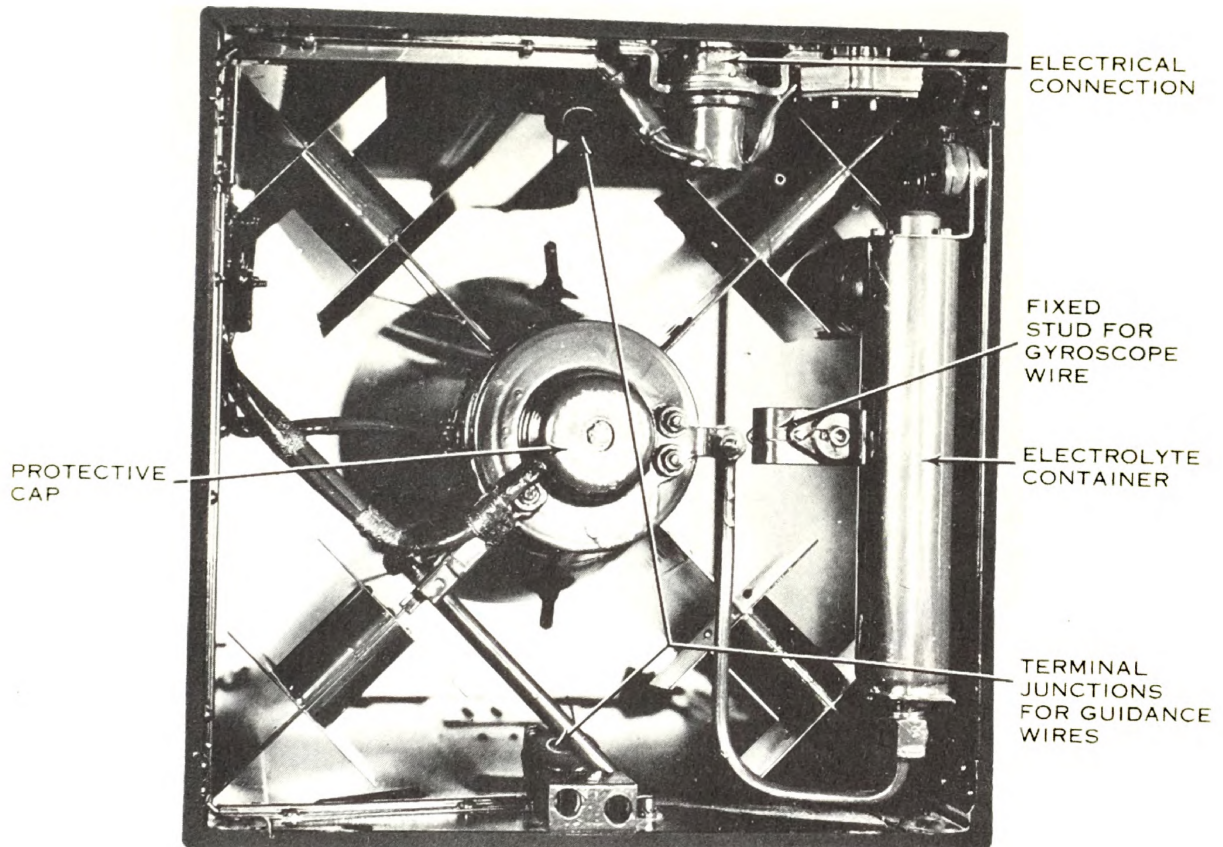

2 Rear view

Figure 15—Continued.

11. Selection Box

a. The selection box (fig. 11) consists of the following:

- (1) A protective cover and fastening straps.
- (2) Four numbered missile cable connections.
- (3) A connection cover.
- (4) A flare cutoff switch.
- (5) A 1.5 meter cable, permanently attached.
- (6) A carrying strap.

b. The purpose of the selection box is to transmit commands from the 100-meter cable assembly to the selected missile via the missile cables. Relays in the box insure that the missile selected will be fired. The flare cutoff switch controls flare ignition for all missiles connected

to the selection box. The 1.5 meter cable is connected to the 100-meter reel assembly, and can also be connected to the $\frac{1}{4}$ and $\frac{5}{8}$ settings on the guidance unit.

12. Cables and Reel Assembly

a. The 100-meter cable and reel (fig. 12) assemblies provide the extension cables for launching "distant" missiles and the means of transmitting launch and guidance commands to the selection box. The reel is mounted on a frame and is equipped with a handle. The handle is used to wind the cable and to lock the reel when not in use. Located on the side of the reel is the cable connection for the 1.5 meter cable on the selection box.

b. Missile cables are attached from the selection box or guidance unit. (A and B connections) to the missile launching container. They are 10 meters in length, with a connector and

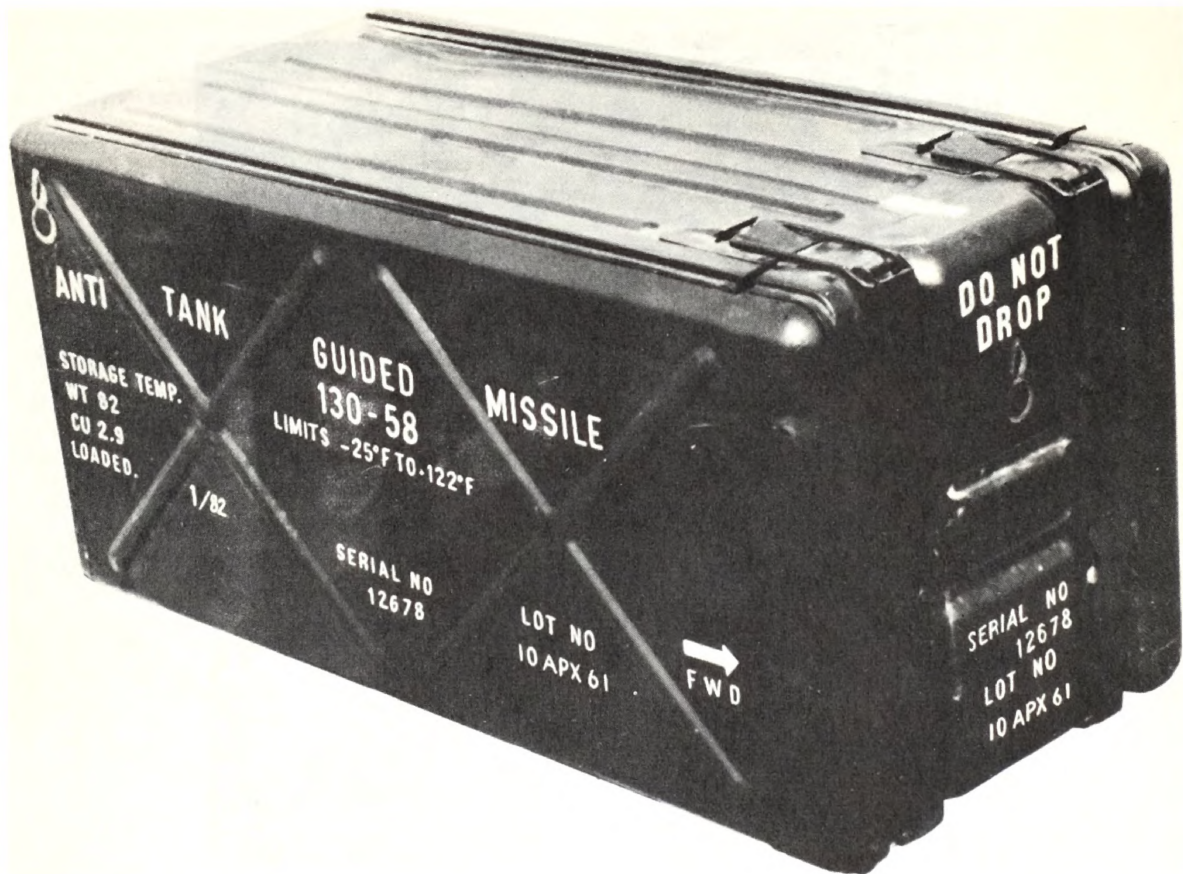

Figure 16. Shipping container.

cover at each end. Caution should be taken to prevent the cable being placed in the backblast area of the missile.

13. Circuit Test Set

a. The circuit test set (fig. 13) is used to check the operation of the guidance system to include the firing sequence and the quality of the guidance signals. It contains the following components:

- (1) Cable connections.
- (2) Maltese cross indicators.
- (3) Test button.
- (4) Pitch and yaw switch.
- (5) A milliammeter.

b. The missile cable to be tested is attached to the connection provided. The circuits are represented by maltese cross indicators, which pivot, showing a white pattern, indicating the

circuit is functioning correctly. The circuits represented are the external battery on the launching container (), booster motor () and flare (). The flare may or may not be tested depending upon whether the gunner desires to fire with the flare on or off. The test button must be depressed when testing the booster and flare. When testing the pitch (up or down movements) the switch must be pointing toward the letter H. When testing the yaw (left and right movements) the switch must be pointing toward the letter D. All readings on the pitch and yaw test will be obtained by observing the needle on the milliammeter.

c. For the conduct of a circuit test, see paragraph 41.

14. Battery Charger

The battery charger (fig. 14) is used to recharge the nickel cadmium battery. It may

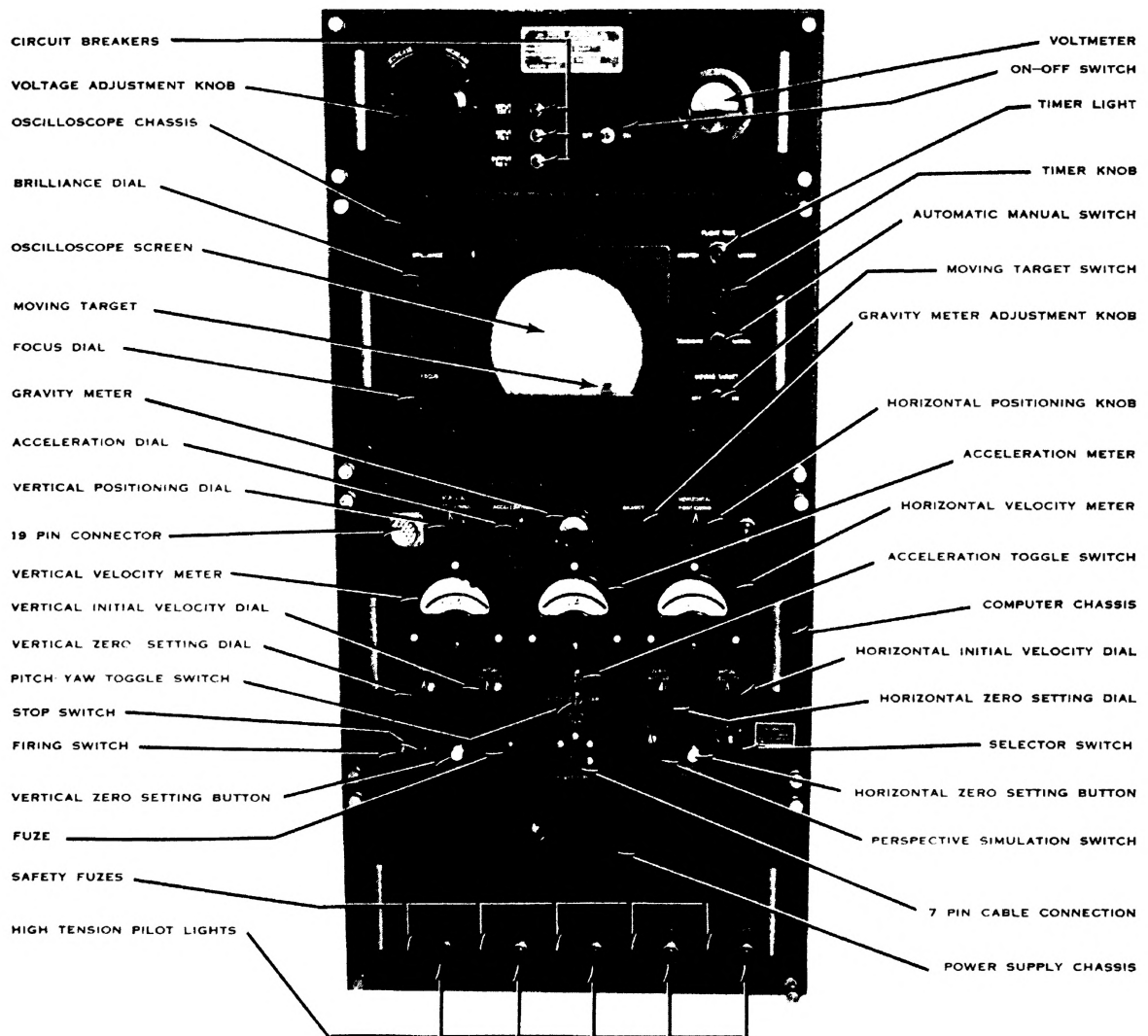

Figure 17. Simulator S-58.

be adapted to any standard vehicle by using the cable assembly provided and tying into the 24-volt electrical system, or it may be used with a rectifier on either AC or DC current provided no more than 24 volts are used. Three battery chargers are organic to each set of equipment.

15. Launching Container

a. The launching container (fig. 15) is a vented, steel box equipped with a ramp and carrying strap. Integral parts of the launching container include—

- (1) A 10 pin cable connection.

- (2) A container for the electrolyte for the missile battery.
- (3) A fixed stud for the wire that initiates the rotor action of the gyroscope.
- (4) A flash tube for charging the missile's battery.
- (5) Two junction boxes for the attachment of the guidance wires.
- (6) The wires for ignition of the booster motor and the pyrotechnic flare.

b. On the forward bottom portion of the launching container is the hinged ramp. Two anchoring pins are provided, under the ramp,

to anchor it to the ground, thus preventing the launching container from flipping over. The flipping action causes the guidance wires to be cut by the sharp edge of the container. Attached to the inside, top front of the container are three metal rods which can be used to anchor the container or to provide an increase or decrease in elevation.

16. Shipping Container

The shipping container (fig. 16) is a ribbed, reinforced, aluminum container, and weighs 82 pounds packed with a missile. The missile launching container and warhead are removed by opening one end of the shipping container. For more details see paragraph 5 (fig. 3).

17. Simulator S-58

a. The simulator (fig. 17) is an electronic device used for training gunners. It is used in marksmanship training and for maintaining gunner proficiency after the completion of range firing. The simulator incorporates a cathode ray oscilloscope (similar to a television screen) on which is projected a blue spot of light representing the flare of a missile. The student controls this spot of light by means of the control stick on the guidance unit. The simulator is comprised of a basic electronic cabinet containing four drawers or "chassis."

b. The top drawer, or power input chassis, contains the power regulating auto-transformer with a 110-220 volt change shunt. It also contains the voltage adjustment knob, voltage meter, cooling fan, on-off switch, and three circuit breakers.

- (1) The on-off switch turns the simulator on or off. It also controls the cooling fan. The switch should be in the off position when connecting the simulator to the electrical outlet.
- (2) The voltage adjustment knob is used with the voltage meter to adjust the proper voltage input indicated in red on the voltage meter. The adjustment knob should be turned to the left before turning on the simulator. Adjustments in voltage can be made by turning the adjustment knob to the right until the needle in the voltage

meter is resting in the red area. Normal operating voltage is between 110 and 130 volts.

- (3) The cooling fan circulates air through the simulator by means of two vents; one on the side of the simulator near the bottom and one on top.
- (4) The circuit breakers will open when the circuit is overloaded. To reset the circuit breakers, turn the on-off switch to the off position, eliminate the overload, and press in on the reset button.

Caution: Never place coverings over vents when in operation.

c. The second drawer, or oscilloscope chassis, contains primarily the cathode ray oscilloscope. Directly in front of and at the bottom of the screen is a small blue plastic square that represents a tank, and is used in moving target exercises. It is mounted on a reversible power-driven screw that causes it to travel from side to side. The drawer also contains the following dials and switches used by the operator of the simulator.

- (1) The brilliance dial (adjusts the brightness of the blue spot of light).
- (2) The focus dial (adjusts the size of the blue spot of light).
- (3) The timer light (indicates when the simulated flight time has elapsed).
- (4) The timer dial (adjusts the time of the simulated flight and can be varied from approximately 4 to 25 seconds).
- (5) The moving target switch (places the moving target in motion and can be used in conjunction with the automatic-manual switch).
- (6) The automatic-manual switch (changes the control time of the spot). In the manual position, the spot can be controlled for long periods of time. In the automatic position, the spot returns to the starting position after the pre-set flight time has elapsed.

d. The third drawer, or computer chassis, contains the alignment circuits and computers

necessary for the functioning of the simulator. Located on the front of this drawer are the principle control dials and meters used in the operation of the simulator during training.

- (1) The vertical and horizontal positioning knobs vary the starting position of the blue spot of light on the screen of the cathode ray oscilloscope.
- (2) The acceleration meter is used with the acceleration dial and toggle switch for the adjustment of the response of the blue spot of light to control stick movements. This meter is graduated from 0 to 100 right and left of center. The response can be adjusted in either direction and the result is the same.
- (3) The effect of gravity on the blue spot of light can be adjusted by use of gravity meter and dial. By varying the gravity, the stabilization position of the control stick is varied, as is the degree of up and down commands required to control the blue spot. This meter is graduated from 0 to 2.
- (4) The horizontal velocity meter is used in conjunction with the horizontal initial velocity dial to vary the apparent speed of the blue spot of light in the horizontal plane. The meter is graduated from 0 to 100, right and left of center. The dial may be set to the right or left of center, and the spot will move accordingly.
- (5) The horizontal zero setting dial is used with the horizontal setting button. To adjust the horizontal meter to zero, depress the zero setting button and adjust the zero setting dial until the needle is in the center position or directly over zero.
- (6) The vertical velocity meter is used with the vertical initial velocity dial to vary the apparent speed of the blue spot in the vertical plane. This meter is graduated from 0 to 100 right and left of center. When the dial is placed to the right of zero the spot will move down; placed to the left of zero it will move up from its starting position.

- (7) The vertical zero setting dial is used with the vertical zero setting button and is adjusted in the same manner as the horizontal zero setting, see (5) above.
- (8) The pitch and yaw toggle switch can be positioned in any of three positions. In the pitch position, the blue spot will move in the vertical plane only; in the yaw position it will move in the horizontal plane. In the center position, the blue spot can be controlled in both planes simultaneously.
- (9) There is a three position selector switch marked "E," "N," and "R." In The "E" (ENTAC) position the ENTAC guidance unit is used with the simulator. In the "N" (NORMAL) position, SS-10/SS-11 guidance units with their signal generator can be used. In the "R" (RESTRICTED) position, the SS-10/SS-11 guidance unit can be cabled directly to the simulator and eliminate the use of a signal generator.

Caution: To change from one position to another, you must turn off the simulator.

- (10) The firing switch is used in reduced simulation (R).
- (11) The 110-volt line fuze protects the power transformer.
- (12) The 19 pin connector is used with a "cyclops" spot projector. This projector can project a spot of light on a separate screen but it is not a normal component of the S-58 simulator as purchased by the Army.

e. The lower drawer, or power supply chassis, contains transformers which supply power for the computer drawer. The power drawer panel has five fuze holders and five high tension pilot lights for the high voltage circuits.

f. The operational range of the various meters on the simulator varies with the individual simulators. The operator will have to establish the numerical values which correspond to the adjectives, slow, medium, and fast, as indicated in figure 18, gunner training.

18. Simulator Operation

a. Since the line cord is only three meters long, place the simulator within this distance of a 5 amp, 110 or 220 volt, 60-cycle outlet.

Caution: Prior to operation, Ordnance personnel should check the simulator to insure that the autotransformer shunt is in the position corresponding to the line voltage (110 or 220 volts). Dangerous high voltages are developed in the trainer. Operators and organizational maintenance personnel are not authorized to make any internal repairs or to remove any chassis from the cabinet.

b. Insure that the on-off switch on the top panel is in the off position; then plug in the line cord.

c. Place the ENTAC guidance unit a minimum of two meters from the simulator, with the target orientation arrow pointed at the simulator.

d. Using the special cable provided with the simulator, connect one end of the "A" or "B" connections on the ENTAC guidance unit, and the other end to the 7 pin connector located on the computer drawer of the simulator.

e. After making the above connections, the simulator is prepared for operation in the following manner:

- (1) Turn the simulator selector switch to "E" (FOR ENTAC).
- (2) Press the false drawer power switch to the "on" position, and set the voltmeter needle in the red zone, using the voltage adjustment knob.
- (3) Wait for the 5 power drawer pilot lights to light.
- (4) Adjust the computer drawer gravity meter with the gravity knob. Set the meter to "0" for ENTAC training. For SS-10/SS-11 training set the meter to "1."
- (5) Press the acceleration toggle switch to either side. Use the acceleration knob to set the acceleration meter to "28" for ENTAC training ("32" for SS-10/SS-11). Press the acceleration

toggle switch to the other side to insure that the reading is symmetrical.

- (6) By pressing the pitch, zero-set button, set the initial pitch velocity meter to zero, using the zero-set knob. Then set the desired velocity (if any) on the same meter using the initial velocity knob.
- (7) The yaw (horizontal) velocity meter is zeroed and set in the same manner as (6) above.
- (8) Set the blue spot of light at the desired starting point, using the vertical and horizontal positioning knobs. Locating the spot on the oscilloscope screen may require searching with the horizontal and vertical positioning knobs, then adjust the spot to the starting point.
- (9) Adjust the spot to the desired brightness and focus with the brilliance and focus controls.
- (10) Place the pitch-yaw toggle switch in the appropriate position for training. Place it in either pitch or yaw separately, or a combination of the two.
- (11) For unlimited flight time, set the automatic-manual switch to the manual position and disregard the timer light.
- (12) To stop a flight, turn the simulator off, then on again. The blue spot will return to the starting position.
- (13) For limited flight time, place the automatic-manual switch to the automatic position, and adjust the flight time knob to the desired time. When the knob is turned all the way left, flight time will be a minimum of 4 to 6 seconds, depending upon the particular simulator. When the knob is turned all the way right, the time will be 22 to 25 seconds. At the end of the preset flight time the spot will return to the starting position.

Note. When using the simulator with SS-10/SS-11 guidance equipment, and the selector switch on "N," the timer light will remain on, and the buzzer will sound as long as the signal generator firing switch is

closed. In ENTAC training, the timer light only lights for a moment, and the buzzer does not sound.

- (14) Training with the moving target is accomplished by pressing the moving target switch to the "on" position. The

target will begin to move as soon as the firing switch on the guidance station is closed. The target reverses automatically at the end of each traverse and stops at the end of the preset flight time.

Section III. MALFUNCTIONS AND IMMEDIATE ACTION

19. General

A thorough knowledge of possible malfunctions and the required immediate action is necessary to efficiently employ the ENTAC missile system. Malfunctions may be caused by the guidance equipment or the missile. These malfunctions may be further broken down into mechanical or electrical failures.

20. Guidance Equipment Malfunctions

a. Mechanical. These failures are usually due to lack of proper maintenance; e.g., the adjustable rod or tripod on the guidance control unit operates improperly, dirt in the cable connectors, loose or broken connections in the battery well. Equipment malfunctions of this type are rare with proper preventive maintenance, and should be noted and corrected prior to emplacing the missile system for firing.

b. Electrical. Electrical malfunctions with the guidance equipment can almost always be detected by conducting a circuit test using the circuit test set. The test set is virtually fool-proof so trust it and use it. Malfunctions may occur in the firing sequence phase. These are the settings—fire (), booster (), and flare () on the circuit test set.

- (1) If the fire () or battery activation indicator fails to activate, check the voltage in the nickel cadmium battery to insure that 11 to 13.5 volts are being generated. If not, replace the battery and repeat the circuit test.
- (2) If the booster () and flare () indicators fail to activate, check the flare cutoff switch, selection box, 10-meter cable and 100-meter cable in that order. By replacing, in turn, the various components, the

piece of equipment causing the break in the circuit can be isolated.

- (3) When checking the pitch and yaw signals with the circuit test set, a reading of 95 should be obtained at the maximum command positions. If maximum readings are not obtained on the milliammeter, then check the battery in the guidance control unit. If no commands are read, suspect the selection box, cables, and guidance control unit in turn. Replacing the various items, and conducting another circuit test, should isolate the cause of the malfunction.

21. Missile Malfunctions

They are generally undetectable prior to launch. Some malfunctions, of mechanical nature, may be detected by inspection of the missile prior to emplacement.

a. Mechanical. Inspection of the missile, to include the launching container for extraneous material, will uncover many mechanical type malfunctions. A dented launching container will impair launching of the missile, or cause an erratic launch. Inspection of the rear of the launching container may disclose a broken gyroscope wire, ejectable cap, or broken guidance wires. The warhead should be inspected for dents and particular care should be taken to prevent dropping the warhead on the nose switch, thus causing premature detonation of the warhead.

b. Electrical. Electrical malfunctions cannot be detected until after the firing switch is compressed.

- (1) *Failure of the firing sequence.* If nothing happens when the firing switch is squeezed, reset the battery and at-

tempt to fire again. Fire a third time, and if nothing happens, disconnect and conduct a circuit test as explained in paragraph 40.

- (2) *Failure of the booster to ignite.* Check the nickel cadmium battery and attempt to fire three times, as explained in (1) above.
- (3) *Failure of the gyroscope.* After launch the missile will roll and guidance is impossible. Move the three-position switch to the "C" or "S" position, and the missile will crash. Select another missile and continue fire mission.
- (4) *Broken guidance wire.* If at any time a guidance wire breaks, the missile will immediately dive into the ground. Select another missile and continue fire mission.
- (5) *Premature detonation.* If the missile nose switch has been crushed prior to

launch, the warhead will explode as soon as the arming plug is seated (3 to 4 seconds after launch). Select another missile and continue fire mission.

- (6) *Failure to detonate.* If the HEAT warhead fails to detonate on impact, consider the missile armed. Wait 15 minutes before approaching the missile, and destroy it in place. Destruction should be accomplished by qualified personnel only. Care should be taken to insure that when emplacing demolitions the missile is not struck or moved.

Note. Malfunctions that occur should be reported as to type of malfunction and lot number in accordance with AR 385-63 and AR 700-1300-8.

Note. The missile battery of a fired missile is considered dangerous. It will explode after several days exposure to the elements. Fired missiles are still dangerous, so leave them alone. For further details see TM 9-1400-455-12.

Section IV. MAINTENANCE AND STORAGE

22. General

The missile is shipped and stored in a waterproof shipping container. The container should never be opened until the missile is to be fired. The training simulator and guidance equipment should be maintained at a relatively constant temperature for best results. If these items are stored in a warm room and then taken outside in cold weather, the interior of the major components will become moist because of condensation. This will cause the electrical components to "short out."

23. Guidance Equipment

a. The antitank squad is responsible for performing the preventive maintenance on its assigned equipment. Proper preventive main-

tenance will insure proper functioning and increase the operational life of the system.

b. Grit and dirt accumulated by employment and use of the equipment may cause the connectors, dials, and knobs to function improperly. As a result, excessive and improper force would be applied and result in damaged or broken components.

c. Particular care must be taken to reduce rough handling of the guidance equipment, test equipment, and cables. This includes the 100-meter cable which may be damaged if pulled and dragged.

d. Authorized organizational maintenance is outlined below. Equipment requiring maintenance, other than that listed, must be evacuated to the next higher echelon.

Major Components

Procedure

TR-10 guidance control unit.....	Clean all dials, knobs, cable connections, and the battery recess. Clean and inspect rubber boot on control stick. Remove rust and spot paint as necessary. Apply light coat of oil.
----------------------------------	---

Tripod-----	Clean and inspect all sliding and folding parts. Remove rust and spot paint as necessary. Apply light coat of oil.
Selection box-----	Clean all cable connections and covers. Remove rust and spot paint as necessary. Apply light coat of oil to hinges of protective connection cover.
Binoculars-----	Clean lenses and binocular body. Inspect adjustable hinge and eye piece. Apply light coat of oil to hinge as necessary.
Circuit test set-----	Clean and inspect all knobs, dials, and cable connections. Clean leather carrying case. Remove rust and spot paint as necessary.
100-meter reel and stand-----	Clean and inspect cable connections and handcrank. Remove rust and spot paint as necessary. Apply light coat of oil to hinge of handcrank.
Cable reels-----	Clean, remove rust, and spot paint as necessary.
Cables-----	Clean connectors and inspect insulation.

Notes.

1. All cable connector covers should be on when the item is not in use.
2. All cables should be cleaned with soap and water only.
3. Dials and all glass items can be cleaned with denatured alcohol, using a soft cloth. Caution should be taken to prevent alcohol from touching the insulation.

24. Simulator

a. The training simulator is a very fragile and sensitive item of equipment that will not stand up under rough handling. Extreme care must be taken to prevent dropping during movement.

b. The simulator must be protected at all times from severe weather conditions such as rain, snow, sleet, and dust. The plastic cover, issued with the simulator, should be on the simulator when it is not in use.

c. The only repair replacements authorized by the individual soldier is the replacement of fuzes on the exterior of the simulator.

d. Qualified ordnance personnel should make all repairs and inspection on the interior of the simulator since it contains high voltage when in operation and is extremely dangerous.

e. Authorized organizational maintenance is outlined below. Equipment requiring maintenance, other than that listed, must be evacuated to the next higher echelon.

*Component**Procedure*

Cabinet-----	Clean carrying handles and vents. Remove rust and spot paint as necessary. Apply light coat of oil to carrying handles.
All drawers-----	Clean and inspect all dials, knobs, reset buttons, and switches. Clean moving target screw with a very soft brush. Inspect fuzes and clean fuze wells. Clean cable connections. Clean all glass parts with soft cloth dampened with denatured alcohol. Clean line cord and plastic cover with soap and water.

Notes.

1. Caution should be taken to prevent alcohol touching the insulation.
2. The simulator must be disconnected when performing maintenance.

25. Storage

a. Missile. The materials used in the manufacture of the ENTAC, as well as the rather fragile internal arrangement of the electrical components, require that the missile be stored so as to prevent deterioration by atmospheric conditions. In the sealed shipping container missiles are sufficiently protected to permit storage under the same conditions as other ammunition of similar nature. In the field, missiles should be protected from the weather and particularly from temperatures below -25°F . or above 122°F . Improvised shelters must be provided with whatever facilities are available. Storage facilities should be equipped with lightning protection devices, and they should be away from any source of electro-

magnetic waves. Missiles should be stored and transported with the rocket symbol pointing in the direction of least danger.

b. Simulator. The storage cabinet provides sufficient protection for the simulator under normal conditions. It is recommended that the simulator be transported in the storage cabinet when operating in the field. If operating the simulator from the storage cabinet, caution should be taken to prevent overheating.

c. Guidance Equipment. The guidance equipment should be stored in a moisture-free building having a relatively constant temperature. The equipment should never be stored on the ground. It is recommended that the equipment be placed in a covered box prior to storage.

Section V. DECONTAMINATION PROCEDURES

26. Decontamination

Use tarpaulins, or any covering material, over all equipment if chemical, biological, or radiological attacks are anticipated. Keep missiles in shipping containers if possible. Test for contamination using the M15A1 or M18A1 chemical detector kit. Perform the test whether equipment is believed to be contaminated or not, if contaminating materials have been used in the area. If equipment is not contaminated, clean and prepare it for use.

27. Procedures

a. If equipment is contaminated, decontamination personnel must use a complete suit of protective clothing (permeable or impermeable), including impermeable protective gloves and a protective mask.

b. Equipment contaminated with chemicals other than blister agents (V- and G-series) is decontaminated by airing. For faster decontamination apply DS-2 decontaminating agent.

c. Equipment contaminated with blister agents (V- and G-series) is decontaminated as follows:

- (1) Remove all dirt, dust, grease, and oil.
- (2) Expose all components to air.
- (3) Decontaminate all equipment with DS-2 decontaminating agent. Hot, soapy water is also an effective cleaner.
- (4) Use protective ointment, M5, for emergency decontamination.
- (5) Test with detector kit to determine if decontamination is complete.
- (6) Bury (or burn) all rags or wiping materials. Exercise caution to protect personnel against vapors created by burning.

d. For more detailed information, see TM 3-220.

Section VI. DESTRUCTION IN EVENT OF IMMINENT CAPTURE

28. General

a. Destruction of materiel is accomplished on authority delegated by the battalion or higher commander. It is ordered only after all measures are taken to save the equipment.

b. When the commander considers it necessary, he orders the equipment to be destroyed to—

- (1) Prevent its capture by the enemy.
- (2) Prevent its use against his own troops.

- (3) Avoid its abandonment in the combat zone.
- (4) Deprive enemy intelligence agencies knowledge of its existence, functioning, or exact specifications.

c. Methods of destruction should be adequate, uniform and easily followed in the field. They should be as complete as possible within the limitations of time, equipment, and personnel. In any event, the most important components of the system are destroyed or evacuated. The same essential components are destroyed or evacuated on all like units to prevent the enemy assembling a complete system from several damaged ones.

d. Certain methods of destruction require special tools and equipment, such as high explosives and incendiary grenades. Issue of such special equipment and its use are command decisions and depend on the tactical situation.

29. Guidance Equipment

a. The guidance equipment should be destroyed first and in the following sequence:

- (1) Guidance control unit.
- (2) Selection box.
- (3) Cables.
- (4) Other equipment.

b. The guidance control unit and selection box can be effectively destroyed by any of the following methods. The methods described are listed in order of their effectiveness.

- (1) *Disassembly.* Remove the interior chassis and smash all fragile components and tear out as much wiring as possible.
- (2) *Incendiary grenades.* Place one or more incendiary grenades on top of each item of equipment. The grenades will burn through the outside metal case and burn and/or melt the interior components.
- (3) *Demolition material.* Prepare and place a primed charge of at least one pound of high explosive on top of each item of equipment and fire either electrically or nonelectrically.

c. Cables can be destroyed by cutting or breaking wires and by smashing connectors.

d. Destroy binoculars by smashing all optical components.

e. The tripod can be destroyed by bending, breaking, or otherwise damaging all components. Incendiary grenades can also be used.

30. Missiles

a. Time may not permit destruction of all missiles. As an expedient smash one wing of each missile. When time and materials permit a more deliberate effort, use one of the following methods:

- (1) *Demolition materials.* Place missiles in compact piles. Time permitting, the warheads should be removed from the finned body and destroyed separately. Prepare and place a primed charge of high explosive on each warhead or finned body and fire either electrically or nonelectrically.
- (2) *Inflammable materials.* Place missile warheads in compact piles. Cover with all available inflammable material, such as gasoline, oily rags, oil, wood, and brush. Ignite with either incendiary grenades, or tracer fire from small arms.

b. Warheads and missile bodies should always be pointed in the direction of least danger to friendly troops. Personnel involved in the destruction of missiles and warheads must always take protective cover.

31. Simulator

The simulator would normally be located so as to permit sufficient time for evacuation. In the event it cannot be evacuated, it can be destroyed in one of the following methods:

a. *Demolition Material.* Prepare and place a primed charge of at least one pound of high explosive inside the third drawer and fire either electrically or nonelectrically.

b. *Inflammable Material.* Remove the three

bottom drawers. Place them in a compact pile. Cover with all available inflammable material, such as gasoline, oil, oily rags, wood, and brush. Ignite with incendiary grenades, or tracer fire from small arms.

c. Incendiary Grenades. Place one or more incendiary grenades inside the top drawer. The

grenade will burn through each drawer and burn and/or melt the interior components.

d. Disassembly. Remove the four drawers and smash all tubes and fragile components, and tear out as much wiring as possible. Due to the safety factors involved, use small arms fire to render the oscilloscope tube inoperative.

CHAPTER 3

PREPARATORY MARKSMANSHIP TRAINING

Section I. PREPARATORY TRAINING

32. General

Preparatory training teaches essential skills and develops fixed and correct procedures in marksmanship before range firing begins. Thorough instruction and carefully supervised practice in the preparatory phases saves time and ammunition during range firing, and develops techniques and procedures necessary for well-trained gunners and assistant gunners. At the same time, the soldier is conditioned both mentally and physically for range firing.

33. Sequence of training

a. During the initial phase of preparatory marksmanship training, all squad members receive instruction on the description, nomenclature, and functioning of the missile, TR-10 guidance control unit, selection box, circuit test set, cables and reel, training simulator, crew drill, preparation of the missile for launching, and technique of fire. All of these training phases are integrated into the scope of instruction so that each member of the squad becomes familiar with the weapons system prior to range firing.

b. In addition to the instruction received on the missile and its system, certain squad members are required to receive more detailed instruction in certain areas.

- (1) The squad leader and No. 4 ammunition handler must be instructed on radiotelephone procedures, communication security, electronic warfare, radio set AN/PRC-25, *Signal Operations Instruction (SOI)* and *Standing Signals Instructions (SSI)*, authentication systems, codes and ciphers, field wire splices, telephone switchboards, and wire nets. In addition, the squad leader receives the necessary tactical instruction that will provide him with the knowledge required to tactically employ the squad.
- (2) The No. 5 ammunition handler is instructed on driver training, loading and lashing of cargo, field expedients, and recovery methods. Both ammunition handlers are trained in ammunition storage, handling, and transportation.
- (3) The assistant gunner must be instructed on driver training as he is the driver for the squad's vehicle.
- (4) As training progresses, squad members should be cross-trained in each area of responsibility.

Section II. SIMULATOR TRAINING

34. General

The S-58 training simulator is utilized during preparatory marksmanship training to teach each individual the fundamentals and correct procedures in controlling the missile. Through the use of the simulator, the student learns control stick manipulations and elimi-

nates many of the problems involved in controlling the flight of the missile to the target.

35. Sequence of Training

a. Simulator training is divided into 46 periods of 15 to 20 minutes each (fig. 18). These periods are integrated within the train-

ing program and are arranged progressively. The first 40 periods are conducted prior to range firing and are designed to teach the student to control the blue spot of light (simulated missile) by use of the control stick on the guidance unit. The final six periods are conducted during range firing and are used by the instructor to correct errors noted during firing.

b. Initially, the student is oriented as to what is expected of him during the gunner training periods. This orientation will cover operation of the training simulator and flight critique of the controlled missile flight. Flight critiques and evaluation involve an explanation as to how the student will be corrected on the errors made during a simulated flight. This is necessary so that the student will understand the corrections made by the instructor. The student is also instructed on the proper position of the hands and fingers for best control stick manipulation.

c. The 15 to 20 minute period, as mentioned in *a* above, is the normal time the training simulator can be operated each hour, by one student, without undue fatigue on the student's eyes. The student should not receive more than four periods of simulator training during any one day.

d. Periods 1 through 4 are designed to teach the student smooth control stick movements and to stop or stabilize the spot at the end of each line in the horizontal and vertical plane. The spot is locked in each plane for these periods of training.

e. In period 5, the student is required to control a free spot which incorporates both horizontal and vertical movements.

f. Period 6 requires oblique or combination commands by manipulation of the control stick. Emphasis is on smooth control stick movement and keeping the spot between the lines.

g. Period 7 requires circular movements and combination commands at the same time. Emphasis is still on smooth control stick movements and keeping the spot between the lines.

h. Periods 8 and 9 include all previous commands. Stabilization is required at each end of the line. Period 9 is timed and requires the

student to trace the patterns within the time allocated.

i. Period 10 requires the student to stabilize the spot and guide it without erratic movements.

j. Period 11 starts the first instruction on trajectory and stabilization. This exercise requires the student to capture (gain control of the spot) and stabilize approximately two target heights above the target (the cross), shift into the binoculars, lower the spot to the target (indicated by circle), and stabilize on the target. The exercise requires smooth control stick movements and a smooth shift into the binoculars without allowing the control stick to move. (It is important that the missile be completely stabilized during the binocular shift, or the gunner will not have the missile in his field of vision once he has shifted to the binoculars.)

k. The moving target exercise begins with period 13 and requires the student to practice commands previously discussed. The student should never lead the target, but should superimpose the missile flare (blue spot) on the target's center of mass.

l. All periods that have not been specifically discussed are review exercises with a decrease in time allotted for each successive review.

Note. The horizontal line with diagonal lines, below some patterns, indicates ground. At any time the student allows the spot to touch the "ground," the instructor should turn off the simulator and have the student start again.

m. Flight critique, and its elements are outlined in figure 19.

- (1) Critique and grading of a student is accomplished during simulator training and range firing by experienced personnel.
- (2) Students are not graded during the first four periods. However, general comments such as "didn't keep the spot on line," or "did not stabilize spot," are applicable comments and should be given to the student so that he realizes his mistakes and can immediately correct them.

- (3) Grades given to the student are called "marks." These marks represent a one point value and indicate errors for all columns on the critique sheet (locally reproduced). By totaling these errors, an evaluation can be made of the student's ability to control the spot of light or a live missile during range firing. The smaller the number of marks, the greater the student's potential.
- (4) The evaluator must become familiar with and follow the terms and phrases of the flight critique sheet. Some of these phrases are explained below:
- (a) The *initial command* enables the gunner to gain control of the missile as soon as possible after launch. A *late initial command* will allow the missile to go high; a *fast command* will cause an abrupt change in the trajectory. A *slow initial command* will also allow the missile to go too high.
- (b) A *large command* will cause an abrupt change in the trajectory of the missile. Holding a *down command* too long will cause the missile to dive into the ground or go below the gunner target line.
- (c) Holding a *left* or *right command* too long will cause the missile to pass the gunner target line, requiring an additional *counter command* and additional time to get on the gunner target line.
- (d) When the gunner does not have good control of the missile, it is called "*not stabilizing.*"
- (e) Binocular shift is accomplished when the gunner has control of the missile and has stabilized on or near the target line. If he does not stabilize, he may not find the missile when he shifts to the binoculars.
- (f) It is best to track the missile with the naked eye, up to 800 meters. This should be done by looking under the binoculars. If the gunner looks over the binoculars, the lens may become fogged from his breath.
- (g) A smooth shift to the binoculars is required to prevent losing the missile. The most common error in shifting is hitting the binocular with the headgear.
- Note.* The words "missile" and "spot" are interchangeable in training since the gunner tracks a pyrotechnic flare on the actual missile.

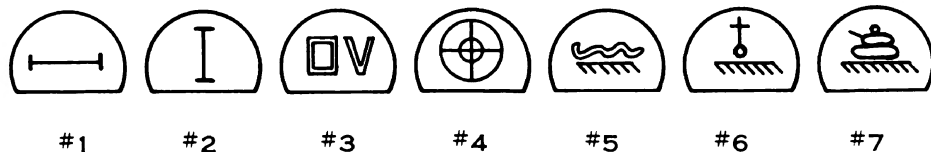

- NOTES: 1. NUMERICAL VALUES WERE ESTABLISHED BY USE OF ONE SIMULATOR AND MAY VARY WITH DIFFERENT SIMULATORS. THE INSTRUCTOR MAY HAVE TO USE THE ADJECTIVES SLOW, MEDIUM, OR FAST IN THE CONDUCT OF TRAINING.
2. GRAVITY IS SET AT "0" FOR ALL ENTAC TRAINING EXERCISES.
3. PATTERNS USED IN GUNNER'S TRAINING ARE MADE OF PLASTIC 1/16-INCH THICK. SPACE BETWEEN LINES OF PATTERNS NUMBER 3 AND 5 IS 1/8-INCH.

Figure 18. Sequence of gunner training.

Period No.	Direction			Initial Velocity		
	UP	R	L	UP	R	L
#1 Horizontal Control		X			0-2 Slow	
#2 Horizontal Control			X			5-7 Med
#3 Vertical Control	X			2-5 Slow		
#4 Vertical Control	X			7-10 Med		
#5 Free spot Straight line	X		X	2-5 Slow		2-5 Slow
#6 Free spot Diagonal line	X	X		5-7 Med	5-7 Med	
#7 Pattern Tracing	X			7-10 Med		
#8 Pattern Tracing	X	X		2-5 Slow	2-5 Slow	
#9 Pattern Tracing	X		X	10-12 Fast		7-10 Med
#10 Stabilization	X			7-10 Med		
#11 Trajectory and Stabilization	X		X	7-10 Med		2-5 Slow

Pattern Time		Starting position	ACC	Points to emphasize
#1		Left Edge of Line	15	<ol style="list-style-type: none"> 1. Continuous smooth control stick movements. 2. Stabilization of spot on end of line without going past end.
#1		Right Edge of Line	15	Same as period #1
#2		Bottom of Line	15	Same as period #1
#2		Bottom of Line	15	Same as period #1
#3 "O"		Bottom Right of Screen	15	<ol style="list-style-type: none"> 1. Continuous control stick movement. 2. Keep spot between lines.
#3 "V"		Bottom Left of Screen	15	Same as period #5
#3 "OV"		Bottom Center of Screen	15	Same as period #5
#5	26 Sec Ea	Bottom Left of Screen	15	<ol style="list-style-type: none"> 1. Continuous smooth control stick movements. 2. Stabilization of spot on points.
#5	26 Sec Ea	Bottom Right of Screen	15	Same as period #8
#4	26 Sec	Bottom Center of Screen	15	Hold spot in center of circle.
#6	22 Sec	Bottom Right of Screen	15	<ol style="list-style-type: none"> 1. Initial movement smooth and continual. 2. Bring spot over target without passing target. 3. Not allowing spot to rise too high. 4. Stabilize above target and shift to binoculars. 5. Smooth lowering to target and stabilization.

AGO 8887A

#12 Trajectory and Stabilization	X	X		10-12 Fast	2-5 Slow	#7	20 Sec
#13 Moving Target	X		X	5-7 Med		2-5 Slow	20 Sec
#14 Pattern Tracing	X	X		7-10 Med	7-10 Med	#5	
#15 Moving Target	X	X		7-10 Med	7-10 Med		20 Sec
#16 Trajectory and Stabilization	X	X		10-12 Fast	2-5 Slow	#6	20 Sec
#17 Moving Target	X			10-12 Fast			18 Sec
#18 Trajectory and Stabilization	X	X		7-10 Med	2-5 Slow	#6	15 Sec
#19 Trajectory and Stabilization	X		X	10-12 Fast		2-5 Slow	#7 15 Sec
#20 Moving Target	X		X	7-10 Med		5-7 Med	15 Sec
#21 Trajectory and Stabilization	X		X	10-12 Fast		2-5 Slow	#6 15 Sec
#22 Moving Target	X			10-12 Fast			15 Sec
#23 Trajectory and Stabilization	X		X	10-12 Fast		5-7 Med	#6 15 Sec

Figure 18—Continu

Bottom Left of Screen	15	Same as period #11
Bottom Right of Screen	20	Same as period #11
Bottom Left of Screen	20	Same as period #9
Bottom Left of Screen	20	Same as period #11
Bottom Left of Screen	20	Same as period #11
Bottom Center of Screen	20	Same as period #11
Bottom Left of Screen	20	Same as period #11
Bottom Right of Screen	20	<ol style="list-style-type: none"> 1. Initial movement smooth and continual. 2. Emphasize the necessity for moving the spot over target rapidly, stabilizing, shifting to binoculars, and stabilizing on target.
Bottom Right of Screen	20	Same as period #19
Bottom Right of Screen	25	Same as period #19
Bottom Center of Screen	25	Same as period #19
Bottom Right of Screen	25	Same as period #19

Period No.	Direction			Initial Velocity		
	UP	R	L	UP	R	L
#24 Trajectory and Stabilization	X	X		7-10 Med	2-5 Slow	
#25 Moving Target	X			7-10 Med		
#26 Pattern Tracing	X		X	2-5 Slow		2-5 Slow
#27 Trajectory and Stabilization	X		X	7-10 Med		2-5 Slow
#28 Moving Target	X		X	10-12 Fast		2-5 Slow
#29 Trajectory and Stabilization	X	X		10-12 Fast	2-5 Slow	
#30 Moving Target	X			7-10 Med		
#31 Trajectory	X			7-10 Med		
#32 Moving Target	X	X		10-12 Fast	2-5 Slow	
#33 Trajectory and Stabilization	X		X	10-12 Fast		7-10 Med
#34 Moving Target	X		X	10-12 Fast		2-5 Slow
#35 Trajectory and Stabilization	X	X		10-12 Fast	2-5 Slow	
#36 Moving Target	X			10-12 Fast		

Pattern Time		Starting position	ACC	Points to emphasize
#7	10 Sec	Bottom Left of Screen	25	Movement smooth and continual moving spot over target rapidly, without stabilizing and shifting to binoculars, but lowering and stabilizing on target.
	10 Sec	Bottom Center of Screen	25	Same as period #24
#5	16 Sec	Bottom Right of Screen	25	Same as period #9
#6	8 Sec	Bottom Right of Screen	25	Same as period #24
	8 Sec	Bottom Center of Screen	25	Same as period #24
#7	12 Sec	Bottom Center of Screen	25	Same as period #11
	15 Sec	Bottom Left of Screen	25	Same as period #11
#6	12 Sec	Bottom Left of Screen	25	Same as period #19
	12 Sec	Bottom Left of Screen	25	Same as period #11
#7	15 Sec	Bottom Right of Screen	25	Same as period #11
	15 Sec	Bottom Center of Screen	25	Same as period #11
#6	18 Sec	Bottom Left of Screen	25	Same as period #11
	18 Sec	Bottom Right of Screen	25	Same as period #11

#37 Trajectory and Stabilization	X		X	10-12 Fast		5-7 Med	#7	15 Sec	Bottom Right of Screen	25	Same as period #19
#38 Moving Target	X	X		7-10 Med	5-7 Med			15 Sec	Bottom Left of Screen	25	Same as period #19
#39 Trajectory and Stabilization	X			10-12 Fast			#6	12 Sec	Bottom Center of Screen	25	Same as period #19
#40 Moving Target	X			10-12 Fast				12 Sec	Bottom Center of Screen	25	Same as period #19
#41 to #46 Refresher Periods											These periods will be utilized by the instructor to continue training in the deficiencies noted during the firing exercises.

Figure 18—Continued.

Figure 19. Flight critique form.

Name John Doe		Rank Pvt		Class ENTAC #4																	
Period	Flights	Initial Command				Binocular Shift		Target		Simulator Score	Range Firing Score										
		Initial Command Late	Initial Command Too Large	Initial Command Incorrect	Command Held Too Long	Passed Target Initial Direction	Allowed Missile To Rise	Late Entering Binoculars	Erratic Stabilization			Stabilized Too High	Did Not Stabilize *	Lowered Too Fast	Lowered Too Slow	Led Target	Grounded Short of Target *	Went Over Target	Erratic Stabilization	Did Not Stabilize	
		/// 3	/// 2	/ 1	// 2	// 2	/// 3	/// 2	/// 3			/// 6	/// 8	/// 2	/// 3	/// 4	/// 6	/// 4	/// 2	/// 3	26
		/// 3	/// 2	/// 2	/// 2	/// 2	/// 3	/// 2	/// 3			/// 6	/// 8	/// 2	/// 3	/// 4	/// 6	/// 4	/// 2	/// 3	18
		/// 3	/// 2	/// 2	/// 2	/// 2	/// 3	/// 2	/// 3			/// 6	/// 8	/// 2	/// 3	/// 4	/// 6	/// 4	/// 2	/// 3	22
		/// 3	/// 2	/// 2	/// 2	/// 2	/// 3	/// 2	/// 3			/// 6	/// 8	/// 2	/// 3	/// 4	/// 6	/// 4	/// 2	/// 3	
		/// 3	/// 2	/// 2	/// 2	/// 2	/// 3	/// 2	/// 3			/// 6	/// 8	/// 2	/// 3	/// 4	/// 6	/// 4	/// 2	/// 3	
		/// 3	/// 2	/// 2	/// 2	/// 2	/// 3	/// 2	/// 3			/// 6	/// 8	/// 2	/// 3	/// 4	/// 6	/// 4	/// 2	/// 3	
		/// 3	/// 2	/// 2	/// 2	/// 2	/// 3	/// 2	/// 3			/// 6	/// 8	/// 2	/// 3	/// 4	/// 6	/// 4	/// 2	/// 3	
		/// 3	/// 2	/// 2	/// 2	/// 2	/// 3	/// 2	/// 3			/// 6	/// 8	/// 2	/// 3	/// 4	/// 6	/// 4	/// 2	/// 3	
		/// 3	/// 2	/// 2	/// 2	/// 2	/// 3	/// 2	/// 3			/// 6	/// 8	/// 2	/// 3	/// 4	/// 6	/// 4	/// 2	/// 3	
		/// 3	/// 2	/// 2	/// 2	/// 2	/// 3	/// 2	/// 3			/// 6	/// 8	/// 2	/// 3	/// 4	/// 6	/// 4	/// 2	/// 3	

Range Firing
 A = Excellent Flight
 B = Good Flight
 C = Average Flight
 D = Poor Flight
 F = Unsatisfactory Flight
 () = Denotes Hit
 * Represents a two point value.

Section III. CREW DRILL

36. Purpose

a. Crew drill develops teamwork, precision, and speed in putting the missile system into action. Precision is achieved by strict adherence to prescribed training procedures. Teamwork is obtained by frequently rotating the duties so each member becomes proficient in the duties of every other member.

b. Practice for speed is the last phase of instruction in crew drill. During this phase, emphasis on precision and teamwork are never sacrificed for speed. Unless otherwise prescribed, move from one position to the next at double time, but perform initial training for precision at quick time.

37. Duties

a. The squad leader is in direct command of the squad, and he is responsible for its equipment. He supervises all actions during crew drill and assists when necessary.

- (1) The gunner (No. 2) is responsible for guiding the missile to the target.
- (2) The assistant gunner (No. 3) assists in placing out missile cables; and under the supervision of the squad leader, he conducts a circuit test. If the necessity arises, he can act as gunner.
- (3) The ammunition handler (No. 4) is responsible for preparing and emplacing the missiles for firing.
- (4) The ammunition handler (No. 5) is responsible for preparing and emplacing the missiles for firing.

b. During the "out of action" phase of crew drill, specific duties are not outlined. Generally, each squad member is responsible for those items he installed. It is the squad leader's responsibility to insure that all members of the squad assist when necessary.

38. Organization

a. Light Method of Launch.

Squad member	Individual weapon	Individual load	Missile equipment
Squad Leader (No. 1)	M14 Rifle	Reel, CE-11, Radio AN/PRC-10, Binoculars.	None.
Gunner (No. 2)	Caliber .45 Pistol	None	Guidance control unit with three batteries.
Assistant Gunner (No. 3)	Caliber .45 Pistol	None	Circuit test set One 10-meter missile cable, one ENTAC missile.
Ammunition Handler (No. 4).	M14 Rifle	None	One ENTAC missile One 10-meter missile cable.
Ammunition Handler (No. 5).	M14 Rifle	None	One ENTAC missile One 10-meter missile cable.

b. Heavy Method of Launch.

Squad member	Individual weapon	Individual load	Missile equipment
Squad Leader (No. 1)	M14 Rifle	Reel CE-11, Radio AN/PRC-10, Binoculars.	None.
Gunner (No. 2)	Caliber .45 Pistol	None	Guidance control unit with three batteries Two 10-meter missile cables.

Squad member	Individual weapon	Individual load	Missile equipment
Assistant Gunner (No. 3).	Caliber .45 Pistol	None	Circuit test set 100-meter cable, selection box.
Ammunition Handler (No. 4).	M14 Rifle	None	Four 10-meter missile cable, 100-meter cable, selection box.
Ammunition Handler (No. 5).	M14 Rifle	None	Four 10-meter missile cables, one ENTAC missile.

39. Light Method of Launch

a. General. This method of launch (fig. 20) provides the highest degree of mobility in ground mounting the ENTAC system. It provides the squad with the capability of positioning and successively firing three ENTAC missiles. This will require disengaging the "A" or "B" missile cable after firing, and connecting the cable for the third prepositioned missile. The light method of employment is normally used in a fast, mobile operation when the resupply vehicle is not immediately available,

requiring the squad to hand-carry the missiles and appropriate guidance equipment. Disadvantages of this method of employment are that all missiles must be located within 10 meters of the gunner and resupply becomes a problem.

b. Form For Crew Drill (fig. 21). At the command "FORM FOR CREW DRILL" squad members fall in at attention behind the missile equipment. The squad leader positions himself three paces in front of the assistant gunner and faces the rank. To assign positions the squad leader commands "COUNT OFF," and calls off

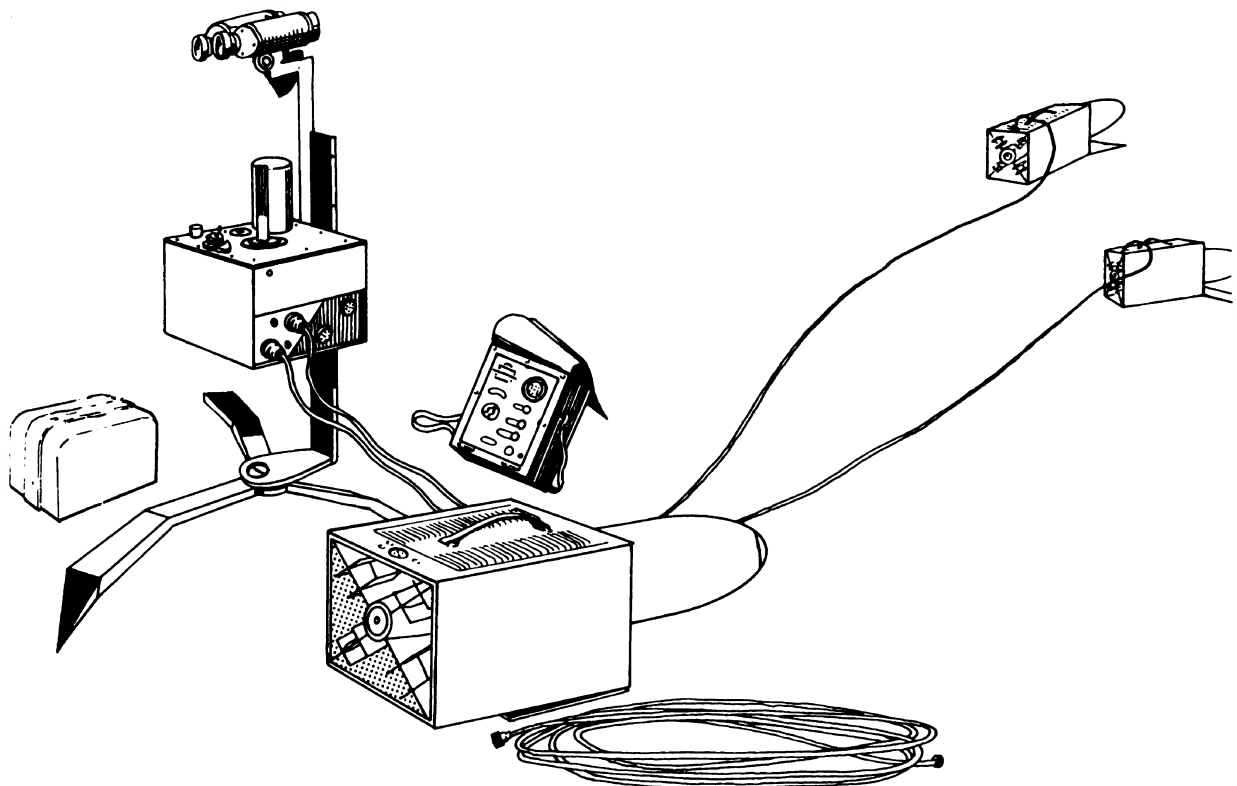

Figure 20. Light method of launch (schematic).

"ONE." Each man then calls off his number from right to left, starting with the No. 2 gunner.

c. Examine Equipment Before Drill. At the command "EXAMINE EQUIPMENT BEFORE DRILL," squad members perform the following checks:

(1) *Gunner—*

- (a) Inspects the folding tripod legs to see if they are functioning properly. At the same time he checks the carrying strap to insure it is not broken.
- (b) Releases the carrying-strap buckle to loosen the strap and removes the cover from the guidance unit.
- (c) Adjusts the height of the control unit by releasing the adjustment catch and elevating it to the desired adjustment notch.
- (d) Checks the binoculars, making certain there are no broken lens and insures that the position of the binoculars can be adjusted with the tubular sliding rod and winged locking nut.
- (e) Checks the battery housing recess and insures that it is free of rust and dirt. Inserts the three dry cell batteries, in turn, into the battery housing recess. As each battery is properly seated, the gunner will depress the test button to insure that each battery gives a reading of 11 to 13.5 volts on the voltmeter. A reading of less than 11 volts indicates that the battery will not furnish enough voltage to operate the guidance unit.
- (f) Checks the voltmeter for broken glass when the batteries are checked.
- (g) Checks the selector dial by rotating it to each of the 10 positions.
- (h) Checks the three-position safety switch and the firing switch to insure that the firing switch can only be compressed while the safety switch is in the "T" (fire) position. When the above checks have been made the gunner places the safety switch in the "S" position.
- (i) Checks the rotating flare cut-off switch to insure it is not "frozen" and is in the "on" position (white line to white line). If the gunner does not desire to use the flare he presses down on the flare cut-off switch and disaligns the two white

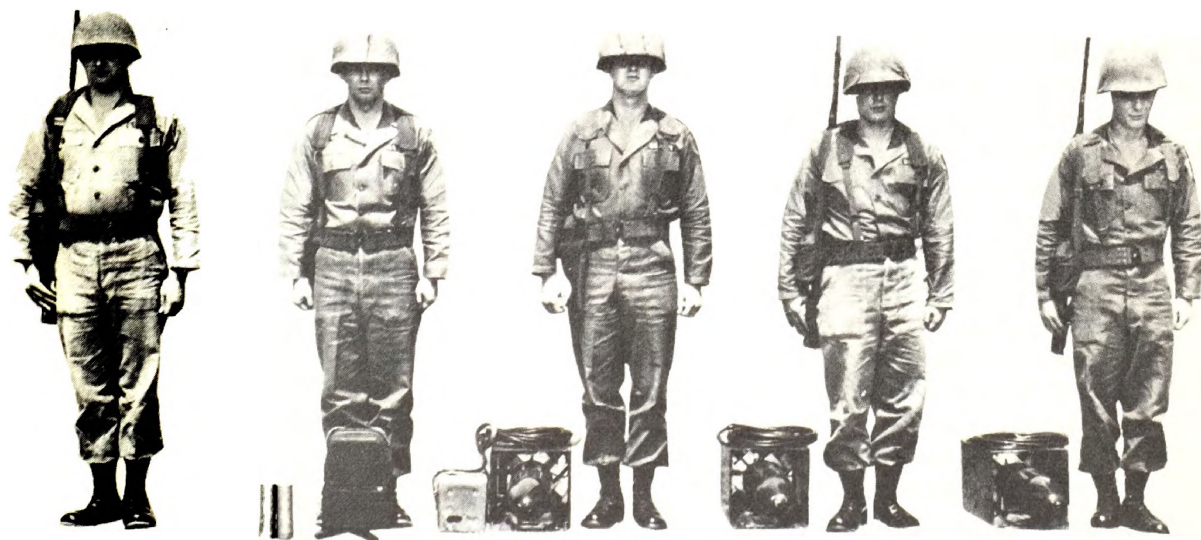

Figure 21. Squad formed for crew drill.

lines by rotating the switch to the right or left.

- (j) Manipulates the control stick to insure it is working freely, and checks the rubber boot around the control stick to insure it is not torn, and is seated properly.
 - (k) Checks the four cable connections on the side of the control box to make certain they are free of dirt and rust.
- (2) *Assistant gunner*—
- (a) Secures the circuit test set and checks the carrying strap and case insuring they are in good condition.
 - (b) Opens the cover of the test set and checks the two-position pitch-yaw switch to insure that it is not “frozen” or exceedingly loose.
 - (c) Depresses the test button and insures that it works freely. At the same time he will visually check for cracked or broken glass on the milliammeter and the three firing sequence indicators.
 - (d) Checks the ENTAC missile to include the carrying strap and cable connection on the launching container.
 - (e) Checks the missile warhead to insure it is properly seated on the finned body.
 - (f) Checks the launching container for dents and insures that it contains two anchoring pins and three metal elevating rods.
 - (g) Checks the ends of the 10-meter missile cable by removing the dust covers and insuring they are free of rust and dirt.
 - (h) Examines the rear end of the missile to insure that the guidance wires are affixed to the junction boxes, that the gyroscope wire is affixed to the fixed metal stud, that no extraneous material is in the launching container, that no electrolyte seepage is seen around the external electrolyte container, and

that the spoiler blades are working freely.

- (3) *Ammunition handler (No. 4)*—
 - (a) Checks the ends of the 10-meter missile cable by removing the dust covers and insuring they are free of rust and dirt.
 - (b) Inspects the ENTAC missile in the same manner as the assistant gunner.
- (4) *Ammunition handler (No. 5)*—

Checks his equipment the same as the No. 4 ammunition handler.
- (5) *Reports:* When all equipment has been inspected as outlined above, the following reports are given in the following order:
 - (a) No. 5 (ammunition handler) CORRECT.
 - (b) No. 4 (ammunition handler) CORRECT.
 - (c) No. 3 (assistant gunner) CORRECT.
 - (d) No. 2 (gunner) ALL CORRECT.
- (6) Any deficiencies noted during inspection would be announced in the report.

d. Prepare to Fire. When the squad reaches the launching site, the squad leader halts the squad and commands, “GUNNER TO BE STATIONED HERE (designates position), DIRECTION OF FIRE (LEFT, RIGHT, FRONT). MISSILES TO BE LOCATED HERE (points to position), ACTION.” The squad then functions as follows:

- (1) *Gunner*—
 - (a) Secures the guidance control unit and the three dry cell batteries and places them in the position designated by the squad leader.
 - (b) Removes the cover from the guidance unit and adjusts the control unit to the desired height.
 - (c) Rotates the binoculars and adjusts the height with the tubular sliding rod.
 - (d) Seats one dry cell battery in its recess on the guidance unit presses the test button to check the voltage,

and insures that the three-position safety switch is in the "S" position.

(2) *Assistant gunner*—

- (a) Secures the circuit test set, one 10-meter missile cable, the ENTAC missile, and goes to the gunner's position.
- (b) Hands one end of the 10-meter missile cable to the gunner and proceeds to the launching site.
- (c) Positions missile on ground using the launching ramp or the three elevating rods and connects the missile cable to the circuit test set.
- (d) Commands: "PREPARE FOR CIRCUIT TEST, CONNECT ALFA CABLE." After receiving the report from the gunner that Alfa cable has been connected, a circuit test will be conducted on Alfa cable, as described in paragraph 40.
- (e) When the circuit test on Alfa cable is completed, the assistant gunner commands "DISCONNECT ALFA CABLE." After receiving a report that this has been done, he connects Alfa cable to the ENTAC missile.

Note. He first insures that the gunner has disconnected the cable from the guidance unit.

- (f) Goes to the next missile launching site and commands: "PREPARE FOR CIRCUIT TEST, CONNECT BRAVO CABLE," and performs a circuit test on Bravo cable.
- (g) Performs same test as with Alfa cable, and connects Bravo cable to the second missile.

Note. If the third ENTAC missile is prepositioned for launching, the assistant gunner will conduct a circuit test on its cable also. However, during crew drill a circuit test on the third cable is not required.

(3) *Ammunition handler No. 4*—

- (a) Secures the 10-meter missile cable and the ENTAC missile. Hands one end of the cable to the gunner and proceeds to the launching site.
- (b) Positions the missile for firing and

places the other end of the missile cable beside the launching container.

- (c) Performs other duties as directed by the squad leader.
- (4) Ammunition handler No. 5—Performs duties as directed by the squad leader.

e. Action. When the squad leader commands "FIRE MISSION" the squad members perform as follows:

(1) *Gunner*—

- (a) Connects the two missile cables to the Alfa and Bravo connections on the guidance control unit and seats the dry cell battery.
- (b) Observes his front through the binoculars making sure he has the most complete coverage possible of the target area.
- (c) Places the selector dial on the "A" "B" setting.
- (d) When the squad leader commands "FIRE WHEN READY" the gunner places the three-position safety switch in the fire position (T) and compresses the firing switch when he feels the target is in the best position to be engaged.

(2) *Assistant gunner*—Performs duties as as designated by the squad leader.

(3) *Ammunition handlers*—Perform duties as directed by the squad leader to include resupply with the spare missile, and local security.

(4) *Squad leader*—

- (a) Supervises the actions of his men and assists as necessary.
- (b) Issues fire commands.

f. Cease Fire. On the squad leader's command "CEASE FIRE" all squad members remain in position while the gunner places the safety switch in the "S" position and unseats the battery, turning it upside down.

g. Out of Action. On the command "OUT OF ACTION" the squad members perform as follows:

- (1) Gunner—
 - (a) Insures that the three-position safety switch is in the "S" position, and that the battery is unseated.
 - (b) Disconnects the two missile cables from the "A" and "B" settings.
 - (c) Returns the guidance control unit to the carry position and returns with equipment to the starting point.
- (2) *Assistant gunner and ammunition handlers*—
 - (a) Disconnect missile cables from launching containers and return missiles to the carry position by securing the ramp and replacing all metal rods.
 - (b) Secure 10-meter cables and missiles, and return to the starting position.
- (3) The squad leader re-forms the squad for the next drill exercise.

40. Heavy Method of Launch

a. General. The heavy method of launch (fig. 22) requires all launching and guidance equipment organic to the squad. With complete equipment, it provides the capability of pre-positioning and successively firing 10 missiles. However, with hand-carry loads, the squad can only carry one ENTAC missile in addition to the guidance equipment. Thus, to employ this method, the resupply vehicle must be reasonably available to the firing site. Greater positioning flexibility is provided with this method in that the gunner can be 110 meters away from eight of the missiles. The basic difference between the two methods of employment is determined primarily by weight. With the light method of employment, three missiles and a minimum amount of guidance equipment are carried by the squad. With the heavy method, all guidance equipment can be carried and positioned, since the resupply vehicle with the missiles will be readily available to the launching site.

Note. With the heavy method, the squad carries and positions the guidance equipment first so that the assistant gunner can conduct circuit tests on the cables while the ammunition handlers return to the vehicle for missiles.

b. Form for Crew Drill. The procedures in forming for crew drill are the same as those for the light method of employment, except for the use of additional items of guidance equipment.

c. Examine Equipment Before Drill. At the command "EXAMINE EQUIPMENT BEFORE DRILL," the squad members perform equipment checks as follows:

- (1) *Gunner*—Same as paragraph 39c(1); and he checks the cable connections of the two 10-meters missile cables, insuring they are free of dirt and rust.
- (2) *Assistant gunner*—Same as paragraph 39c(2) except for actions concerning the ENTAC missile. In addition he—
 - (a) Secures the selection box and checks the carrying strap making certain it is not broken.
 - (b) Opens the cover of the selection box and releases the protective cover of the cable connector.
 - (c) Checks the cable connectors, insuring they are free of dirt and rust.
 - (d) Checks the flare cutoff switch on the selection box, insuring it is in the "on" position (white line to white line).
 - (e) Secures the 100-meter cable assembly and inspects the cable holding straps.
 - (f) Rotates the operating handle (unlocking the handle) and places it in the operating position, making sure it locks in place.
 - (g) Turns the cable reel assembly, using the operating handle, to insure that it operates freely.
 - (h) Depresses the operating handle locking button and returns the handle to its travel position.
- (3) *Ammunition handler No. 4*—Performs the same equipment checks as the assistant gunner in (2) above except those actions pertaining to the circuit test set.

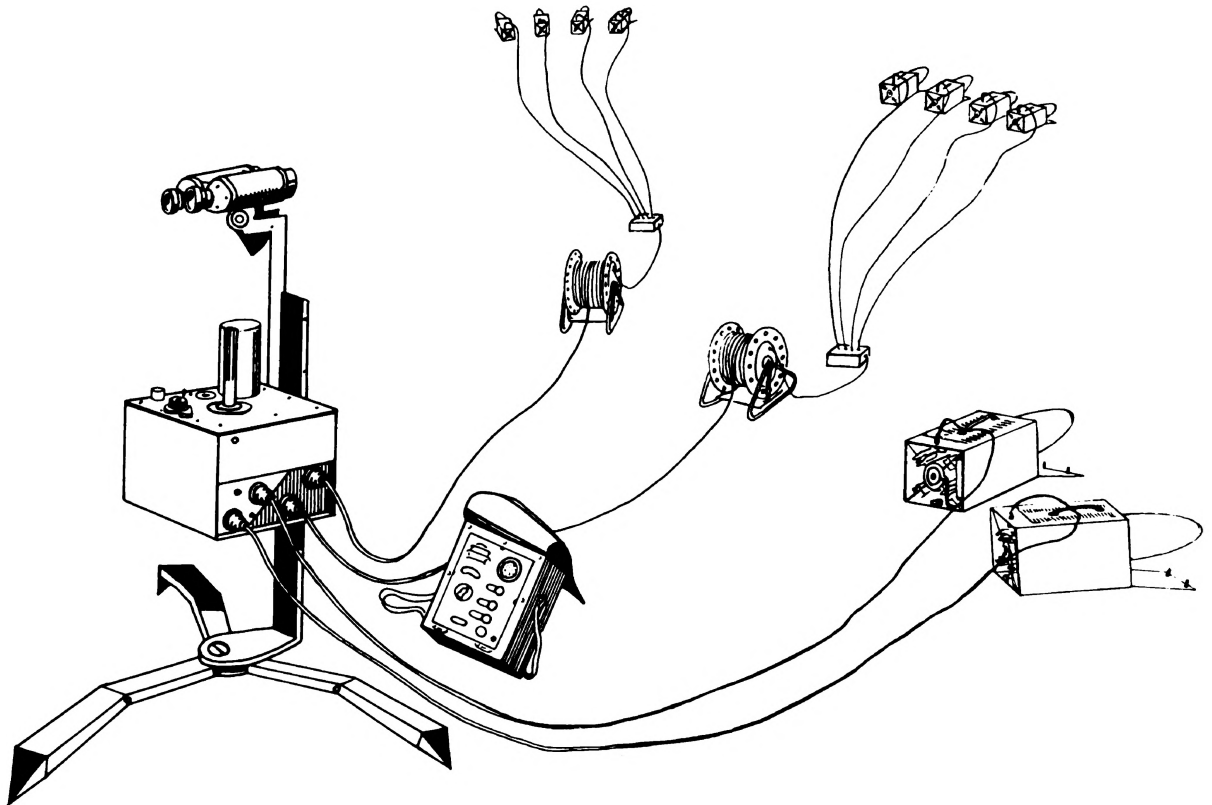

Figure 22. Heavy method of launch (schematic).

- (4) *Ammunition handler No. 5*—Checks the four missile cables and the ENTAC missile.
- (5) *Reports.* When all equipment is checked the squad members report in the same manner as during a light method of launch equipment check.

d. Prepare to Fire. After the gunner has reported all correct, the squad leader commands: "GUNNER TO BE STATIONED HERE (designates position); DIRECTION OF FIRE (FRONT, LEFT, etc.); CLOSE MISSILES TO BE LOCATED HERE (points); DISTANT MISSILES TO BE LOCATED (100 METERS, etc., FRONT, LEFT FRONT, etc.); ACTION." On the command "ACTION" the squad members function as follows:

- (1) The gunner moves to the area, designated by the squad leader, with the guidance control unit, batteries, and two 10-meter cables. The assistant gunner secures the two running ends

of the 10-meter cables and moves to the designated location for the "A" and "B" missiles, with the circuit test set. The No. 5 ammunition handler carries one missile to the "A" missile location and emplaces it while the assistant gunner and gunner are conducting a circuit test on the "A" and "B" missile cables (para. 40).

- (2) At the command "ACTION," the No. 4 ammunition handler moves to the supply vehicle and secures two additional missiles. He leaves one at the squad's equipment location and brings the other to the "B" missile location and emplaces it. After the assistant gunner has completed the circuit test on the "B" cable and connected the "A" and "B" cables to the missiles, the squad re-forms on its equipment.
- (3) The assistant gunner secures one 100-meter cable, and one selection box, and the No. 4 ammunition handler

secures the other 100-meter cable, selection box, and four 10-meter cables. Both squad members move to the gunner's location and hand him the running end of the 100-meter cables, unlocking the operating handles and moving to the area designated by the squad leader for the distant 1-4, 5-8 missiles.

- (4) The assistant gunner moves to the 1-4 missile location and emplaces the 100-meter reel. Then he unwinds one turn of cable off the reel for slack, locks the operating handle, and connects the selection box to the connection in the side of the 100-meter reel. The No. 5 ammunition handler secures one missile and four 10-meter missile cables and moves to the 1-4 missile location with the assistant gunner. While the No. 5 ammunition handler emplaces the missile, the assistant gunner conducts a complete circuit test on the first 10-meter cable. The assistant gunner then conducts a firing sequence check on the next three missile cables (2-4) while the ammunition handler (No. 5) secures three additional missiles from the vehicle and emplaces them in position.
- (5) The No. 4 ammunition handler moves concurrently to the 5-8 missile location and connects the system in the same manner as discussed in (4) above. After he has emplaced the cables he moves back to the resupply vehicle and obtains four additional missiles (5-8).
- (6) When the assistant gunner completes the 1-4 test, he moves to the 5-8 missile cables and conducts a complete circuit test on missile cable number 5. As he completes the circuit test on number 5 cable, and firing sequence tests on cables 6-8, the No. 4 ammunition handler emplaces missiles 5-8. Upon completion of the heavy method, with all missiles emplaced, the squad re-forms and awaits further instructions.

- (7) The squad leader supervises the action of the squad by placing himself wherever needed.

e. Action. At the squad leader's command "FIRE MISSION" the squad members function as follows:

- (1) *Gunner*—
 - (a) Connects all missile cables to the guidance control unit.
 - (b) Engages the battery in the battery well.
 - (c) Observes the target area and adjusts his binoculars as necessary.
 - (d) Awaits the next command.
 - (e) Selects the missile to be fired.
 - (f) When the squad leader commands "FIRE WHEN READY" the gunner places the three-position safety switch in the fire position (T) and compresses the firing switch when he feels the target is in the best position to be engaged.
- (2) *Assistant gunner*—Performs duties as directed by the squad leader.
- (3) *Ammunition handlers*—Provide security for the squad and perform duties as directed by the squad leader.

f. Cease Fire. On the squad leader's command "CEASE FIRE" all squad members remain in position while the gunner places the safety switch in the "S" position and unseats the battery, turning it upside down.

g. Out of Action. On the command "OUT OF ACTION" the squad members perform as follows:

- (1) *Gunner*—
 - (a) Insures that the three-position safety switch is in the "S" position and the battery is unseated.
 - (b) Disconnects all cables from the guidance control unit.
 - (c) Returns the guidance control unit to the carry position and returns with equipment to the starting point.
- (2) *Assistant gunner and ammunition handlers*—

- (a) Disconnect missile cables from launching containers and return missiles to the carry position by securing the ramp and replacing all metal rods.
- (b) Return missiles and cables to starting point.
- (3) The squad leader re-forms the squad for the next drill exercise.

41. Circuit Test

a. The circuit test set, organic to each anti-tank squad, is used for checking the firing sequence of the missile and electrical continuity of the guidance equipment. The assistant gunner is responsible for conducting the circuit test prior to connecting a missile for launching.

b. When the assistant gunner has received the report that the cable to be checked has been connected to the guidance control unit, he will order: "FIRE." At this command, the gunner will rotate the safety switch to the "T" (fire) position and compress the firing switch. At this time, the maltese cross indicator on the circuit test set, marked FIRE (⊕), should be activated. The assistant gunner then depresses the test button, at which time the maltese cross indicators marked BOOSTER (⊙) and FLARE (⊙) should activate. The assistant gunner will then release the test button and command "CUT." At this command the gunner will release the firing switch. The firing sequence is conducted three times on each missile cable.

c. After the assistant gunner has checked the firing sequence he will conduct a continuity check of the guidance signals. To do this he first moves the two-position switch to the pitch position and gives the following command to

the gunner: "HIGH." The gunner, with the firing switch compressed, will move the control stick to the full rear position. The assistant gunner will then command "LOW." The gunner will move the control stick from the rear (HIGH) to the front (LOW) in a slow continuous movement. The needle on the circuit test set milliammeter should rise to 100 at the HIGH maximum position then slowly move to 0 at neutral, and to 100 at the LOW maximum position. The assistant gunner then commands "NEUTRAL" and when the gunner moves the stick to the neutral position and releases it the milliammeter needle should move to 0. The assistant gunner now moves the two-position switch to the yaw (D) position. He then commands "LEFT." The gunner, with the firing switch compressed, will push the control stick to the left. The assistant gunner will then command "RIGHT." The gunner will move the control stick from LEFT to RIGHT in a slow continuous movement. The needle on the milliammeter should respond in the same manner as previously described. The needle may quiver slightly out; this is normal. Having checked all cables, the assistant gunner reports "CIRCUIT TEST COMPLETE." The gunner releases the firing switch, moves the control stick to "NEUTRAL," rotates the safety switch to the "S" position, unseats the battery and turns it upside down, and disconnects all cables from the guidance control unit.

d. Each missile cable should be checked for the firing sequence. However, the continuity check is required on only one cable from a selection box. Anytime an item of guidance equipment is replaced, a complete circuit test should be performed.

Note. In tactical unit training a system of signals should be devised for conducting the circuit test.

Section IV. RANGE PROCEDURES AND SAFETY

42. Range Firing

a. Range firing may be conducted on one or more ranges, depending on facilities available. The range selected should be as level as possible from the launching position to the target. This type range will not permit the missile to be flown below the gunner target line, and impresses upon the gunner the importance of

using proper procedure in lowering the missile to the gunner target line.

b. Range firing consists of a total of 10 missiles for gunner qualification and four missiles for assistant gunner qualification. Initially, all student gunners fire four missiles each, at which time they are evaluated, based on the overall course of instruction. Those students

with the greatest potential of becoming good gunners will continue to fire six additional missiles. To be qualified as gunner, the student should attain a minimum of 50 percent hits. Qualification as assistant gunner should be based on 25 percent hits.

c. The initial firing is conducted at ranges greater than 1,500 meters, where possible, and then progressively decreasing the range to 600 meters. This permits the instructor to observe the control stick movements made by the student and to note any errors. Also, it provides the gunner with additional controlled flight time of the missile. Both moving and stationary targets should be engaged.

d. For firing sequence see figure 23.

43. Safety Precautions

a. *General.* There is very little danger associated with the handling, transporting, assembling, and firing of the missile provided the safety instructions listed below are strictly observed. Safety hazards can arise from—

- (1) Propellant gases, with their accompanying heat and blast, exhausting to the rear from the booster motor.
- (2) Forward impact of the missile itself.
- (3) Explosion of the warhead.

b. *Transporting.*

- (1) Missiles carried in vehicles, other than the launching vehicle, should always be transported in their shipping container with the cover fastened.
- (2) Other explosives must not be transported with the missiles.
- (3) Smoking is prohibited within 50 meters of any missile position.
- (4) The motor of the vehicle will be turned off during loading and unloading.
- (5) Missile containers should be lined up with the rocket symbol on the container pointing toward the rear.
- (6) All transporting vehicles must comply with all local rules and regulations regarding the transport of munitions. As an example, all vehicles should have two filled fire extinguishers, one of which should be CO₂. Vehicles should display large signs

marked EXPLOSIVES in 8-inch letters on the front, rear, and sides.

c. *Handling, Assembling, and Firing.*

- (1) Be extremely careful with the warhead. If the warhead nose is damaged it may cause premature detonation of the warhead. Avoid carrying the warhead by the carrying strap, as the plastic connection will tear easily.
- (2) When assembling the missile, be sure the base of the warhead is not damaged.
- (3) Be sure the electrical contacts, the male and female fittings, of the finned body and warhead are mated before pushing in on the warhead.
- (4) Be sure the launching container is properly anchored.
- (5) Missile cables are connected to the missiles only on order of the squad leader or instructor.
- (6) Missile cables are not connected until the following preliminary checks of guidance equipment have been made.
 - (a) All cables will remain disconnected from the guidance unit until the alert of "FIRE MISSION" is given.
 - (b) The nickel cadmium battery may be removed as an additional safety precaution.
 - (c) The safety switch must be in the "S" or safe position.
- (7) Approach a missile from the side, never from the rear.
- (8) Attach the missile cable while kneeling alongside the launching container.
- (9) In the event the missile with a live warhead fails to launch, and the motors ignite, evacuate the area immediately. The missile will become armed, and remain armed, for approximately 40 seconds. Contact explosive ordnance disposal personnel to dispose of the malfunction.
- (10) If a missile with a target practice warhead fails to launch or launches and immediately impacts, wait at least five minutes before approaching it.

Missile No.	Range (Meters)	Target description	Type warhead	Gunner location
1	1500-1900	Tank, stationary.	Inert	Near launch site, offset to rear. Be cautious of back-blast area.
2	1300-1800	Tank, stationary.	Inert	Offset 30 meters left or right.
3	1000-1300	Target tank moving perpendicular to firing position.	Inert	Offset 10 meters left or right.
4	1000-1300	Target tank moving perpendicular to firing position.	Inert	
5	1000-1300	Target tank moving perpendicular to firing position.	Inert	Offset 10 meters right or left.
6	1000-1300	Target tank moving perpendicular to firing position.	Inert	Offset 10 meters right or left.
7	800-1000	Target tank moving perpendicular to firing position.	Inert	
8	1000-1200	Tank, stationary.	Inert	Near launch site, offset to rear. Be cautious of back-blast area.
9	1200-1600	Tank, stationary.	HEAT	Offset 30 to 50 meters right or left.
10	600-1000	Tank, stationary.	Inert	Offset with missiles 30 to 50 meters right or left rear.

Figure 23. Sequence of firing.

- (11) When firing the missile, keep all personnel clear of the area (extending 50 meters to the rear and in a fan of 60 degrees).
- (12) This missile should not be fired over the heads of friendly troops, except in an emergency, and then only when it cannot be avoided.
- (13) The area directly in front of the missile and extending 60 degrees to the right and left of the launching azimuth is a danger area and personnel should be kept out of it (fig. 24).
- (14) If a missile should leave the safety zone, rotate the safety switch to the safe (S) position and the missile will be grounded immediately.

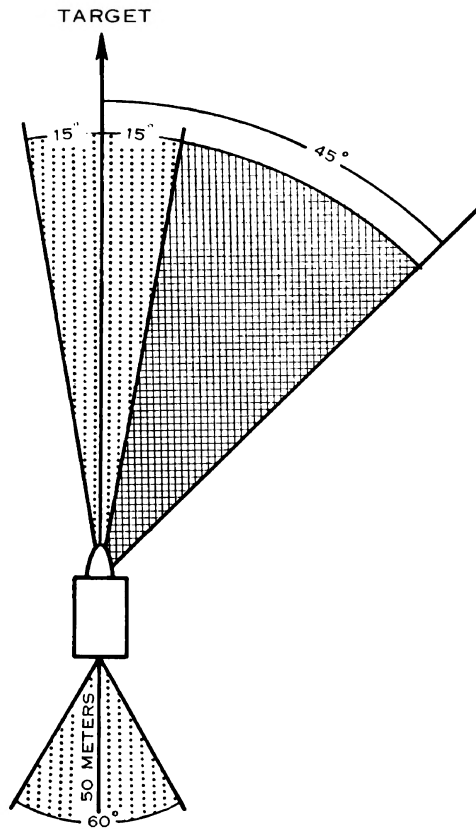

 MISSILE DANGER AREA

 CAUTION AREA

Figure 24. Danger area (schematic).

CHAPTER 4

TECHNIQUE OF FIRE

Section I. GENERAL

44. Introduction

The operation involved in placing effective fire on a target is called technique of fire. Since no two combat situations will be exactly alike, no single method will apply to all situations. However, the elements required by an antitank platoon to bring effective fire on a target are discussed in this chapter.

45. Missile Position

The missile can be positioned in defilade, on the forward slope, or on level terrain. But in all cases the missile must have a clear field of fire along its launching azimuth and the gunner must be in a position to see the missile as it is launched or immediately after it has been launched. The missile's line of flight must be free from trees, brush, or other obstacles that would prevent the missile from reaching its target.

Section II. RANGE DETERMINATION

46. Range Determination

a. General. Determining range when using the ENTAC missile is necessary because of the missile's minimum and maximum range. The gunner must establish a line at maximum range beyond which he cannot engage a target and also at minimum range inside of which he cannot engage a target. Range must also be determined to any given point within the normal zone of action because of the time/space factor of engaging moving targets.

b. Maps and Photomaps. When a squad leader locates his position on a map he then measures the distance (400 to 2,000 meters) on the map and locates a prominent terrain feature on the ground that corresponds to this range on the map. He then establishes a line along recognized terrain features as his minimum and maximum range. Next, range lines are determined at each 400-meter interval within the zone of action.

c. Estimation by Eye. Estimation by eye is the most rapid but least accurate method of determining range. This method requires continuous training to maintain the proficiency necessary to estimate range to any degree of

accuracy. Accuracy is also greatly influenced by the distance to the target. To be consistent, you must be aware of certain factors that influence this application.

- (1) *Nature of target.* A target of regular outline, such as a house or vehicle, appears to be closer than it actually is; but targets of irregular outline, such as trees or camouflaged positions, appear to be more distant. When the target contrasts with its background it appears nearer because the target outline is more clearly defined. If the target blends with the background it appears farther away because it is more difficult to distinguish the target outline. When the entire target is in view it appears closer than when only part of it is visible.
- (2) *Nature of terrain.* The range to be estimated is the air line distance and not the ground distance. In the field, the observer's eye unconsciously tends to follow the irregularities which vegetation and terrain conformation give to the groundline, thus resulting

ENTAC ATGM
TIME/ SPACE FACTOR

Seconds of Flight	Missile Distance in Meters	Tank Speed in MPH - Tank Distance in Meters									
		5	10	15	20	25	30	35	40	45	
3	240	7	13	20	27	34	40	50	54	61	
4	320	9	18	27	36	45	54	63	71	80	
5	400	11	22	34	45	56	67	78	89	100	
6	480	13	27	40	53	67	80	94	107	121	
7	560	16	31	47	62	78	94	110	125	141	
8	640	18	36	54	71	89	107	124	143	161	
9	720	20	40	60	80	101	121	140	160	181	
10	800	22	45	67	89	112	134	156	179	201	
11	880	25	49	74	98	123	147	172	196	221	
12	960	27	54	80	107	134	161	188	214	241	
13	1040	29	58	87	116	145	174	203	232	261	
14	1120	31	62	94	125	156	188	219	250	281	
15	1200	33	67	100	134	168	201	235	268	301	
16	1280	36	71	107	143	179	214	250	286	322	
17	1360	38	76	114	152	190	228	266	304	342	
18	1440	40	80	120	160	201	241	281	321	362	
19	1520	42	85	127	169	212	255	296	339	382	
20	1600	45	89	134	178	223	268	313	357	402	
21	1680	47	94	140	187	235	281	328	375	422	
22	1760	49	98	147	196	246	295	345	393	442	
23	1840	51	103	154	205	257	308	360	411	462	
24	1920	54	108	161	216	268	322	366	429	482	
25	2000	56	112	167	223	279	335	381	447	503	

Figure 25. Time/space factor.

in overestimation of the range. In observing over smooth terrain such as desert, water, snow, or any other situation where there is little to distract the eye, the tendency is to underestimate the range.

- (3) *Visibility.* The more clearly a target can be seen, the closer it appears. A target seen in the full light appears to be closer than the same target seen at dusk or dawn, or through smoke, fog, or rain. The position of the sun with relation to the target also affects the apparent range. When the sun is behind the viewer, the target is in full light and easy to see and thus appears to be closer than it actually is; however, when the sun is behind the target and the viewer is looking into the sun, the target is more difficult to see and appears to be farther away.

d. Rangefinders. Range may be determined by contacting a tank commander or the commander of any weapon equipped with a rangefinder. This is the most accurate method of determining range.

e. Binocular. The binocular and mil relations are useful in deliberate range determination. To use this method, the width of the target or object must be known. Accuracy of this method depends on the knowledge of target dimensions and the ability of the individual to make precise measurements with the binoculars.

47. Time/Space Factor

a. General. The time/space factor (fig. 25) is defined as follows: the time required for the missile to reach its target before the target can

move from one covered position to another. The gunner must be aware of any location within his sector where a tank can take cover. He also must be capable of determining the distance between covered locations as well as determining the distance from the launching position to any of the covered locations.

b. Speed of Target. The speed of the target will be determined to find the time the target must require to move between covered positions. Estimating speed requires continuous training to maintain any degree of accuracy. Accuracy is also greatly influenced by the distance to the target. If the target is moving toward you it appears to be moving much faster than one moving away from you. Also, a target moving perpendicular to the line of sight will appear to move faster than one moving parallel to the line of sight. An example follows:

c. Example. A target is moving laterally across the target area, from one covered position to another. In order to engage the target before it reaches the covered position, the gunner must—

- (1) Estimate the range to the target (1,600 meters).
- (2) Estimate the target's speed (15 miles per hour).
- (3) Estimate the lateral distance between covered positions (100 meters).

Applying the first two of these to the time/space factor scale (fig. 25), the tank distance in the meters column indicates 134 meters, *more* than the gunner's estimated distance between covered positions. Thus, he knows that he would *not* be able to engage the target.

Section III. FIRE COMMANDS

48. General

The rapid engagement of targets with effective fire is dependent on the skills and coordination of the squad. The squad leader is responsible for controlling the fires of the squad and for selecting targets and issuing fire commands.

49. Fire Commands

a. Initial Fire Commands. The initial fire

command issued by the squad leader contains the necessary information to permit the gunner to select and fire a missile. The fire command contains five elements for either stationary or moving targets. The only difference is in the first element (Alert). For a stationary target the alert is FIRE MISSION. For a moving target the alert is MOVING TARGET. Below is an initial fire command showing the cor-

rect element sequence. The gunner repeats all elements of the fire command.

<i>Element</i>	<i>Example</i>
Alert	Fire mission (moving target)
Direction	Front
Range	One four hundred
Description	Tank
Fire Control	When ready

b. Cease Fire. This command is given by the squad leader. On the command CEASE FIRE the gunner places the safety switch in the "S" position and unseats the battery, turning it upside down.

c. Massed Fire. The concentrated, massed fire of the antitank platoon produces a far greater destructive effect than the uncoordinated fires of an equal number of squads. The platoon leader controls distribution of fire by issuing initial fire commands. The following are examples of initial fire commands:

<i>Point target</i>	<i>Area target</i>
Platoon	Platoon
Front	Front
One two hundred	One six hundred
Bunker	First squad—right front
When ready	Second squad—center
	Third squad—left front
	Tanks
	When ready

<i>Ambush</i>
Platoon
Front
One four hundred
First squad—lead tank
Second squad—second tank
Third squad—third tank
When ready

d. Actions of Individual Squads in Massed Fire. Upon receiving a platoon fire command, each squad leader issues an initial fire command to his gunner. The gunner continues to fire until the platoon leader commands "CEASE FIRE."

Section IV. RANGE CARDS

50. Purpose

A range card is a diagram or sketch of an area showing the missile position, prominent terrain features, and probable targets, all in relation to their position on the ground. Range cards aid in firing day or night, and are used for identifying minimum, maximum, right, and left range limitations and probable target locations. Range cards must contain the following information:

- a. Location of missiles and direction of launch.
- b. Minimum and maximum range limitations.
- c. Azimuth of right and left limits of sector.

d. Location of gunner.

51. Preparation

A good range card must be complete, simple, and easy to read. A type range card which meets the requirements is depicted in figure 26. The sketch range card is a simple drawing of the sector of fire capable of being covered. The drawing is schematic, showing the location of the gunner and the launching azimuth of missiles. The left and right limits of the normal zone of action are 622 mils on each side of the launching azimuth. Terrain permitting, maximum and minimum practical ranges are designated by a recognizable terrain feature. Fires are planned within this area (fig. 27).

Section V. NIGHT FIRING AND FIELD FIRING

52. Night Firing

a. Squads must be capable of delivering effective fire during periods of limited visibility. In cases of reduced visibility the gunner must be able to see the target from his position, either by battlefield illumination or by natural light.

b. When firing at night, at either a stationary or moving target, the battlefield must be illuminated so the gunner can see the target. This may be accomplished by using illuminating rounds from the 81-mm and 4.2-inch mortars, 105-mm and 155-mm artillery or airdropped flares. When ignited to the rear of the target

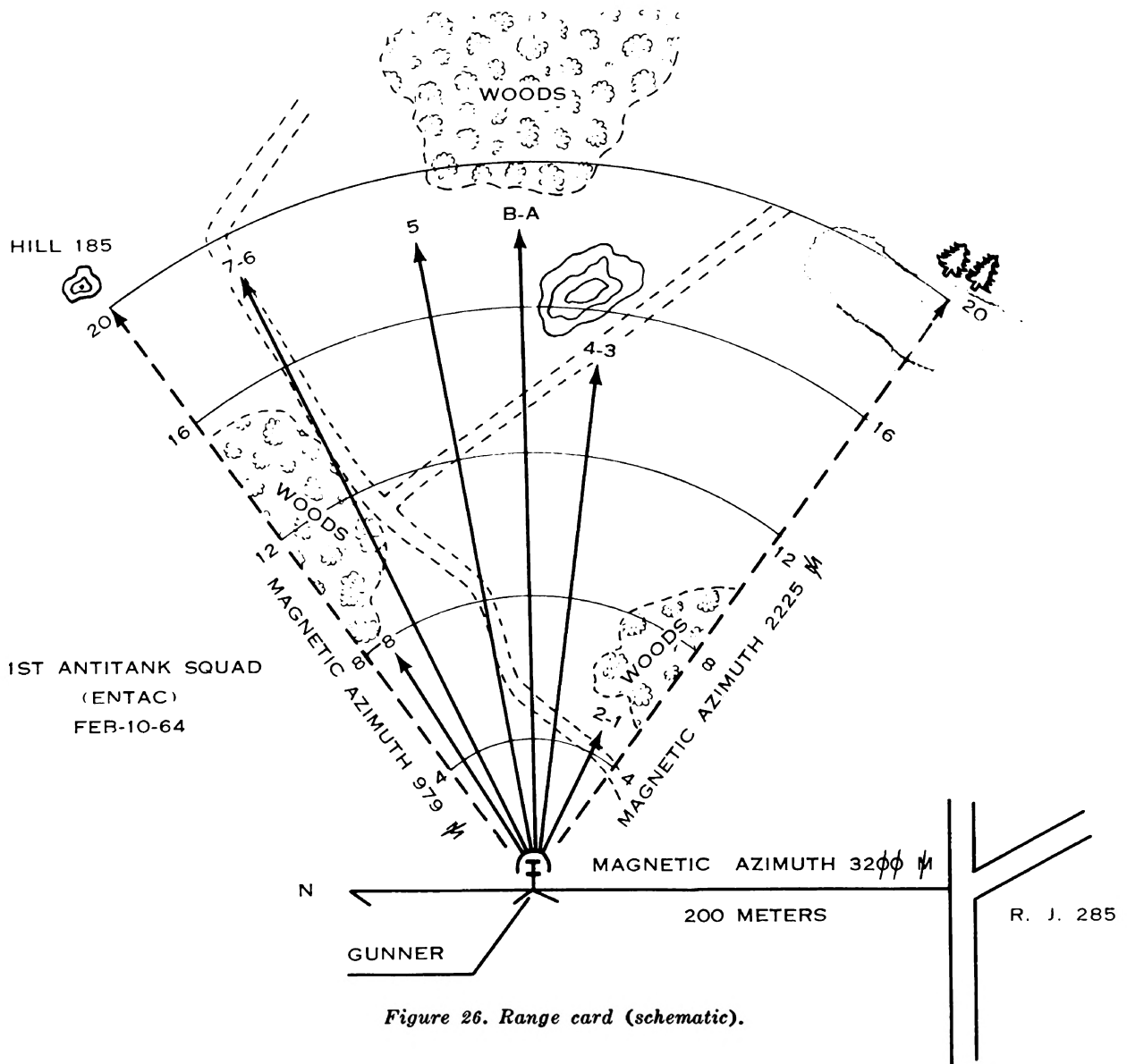

Figure 26. Range card (schematic).

they sufficiently illuminate it so that techniques of target engagement are identical to daylight firing.

c. The missile may be fired under conditions of reduced visibility such as offered by moonlight or "artificial moonlight," the reflection of searchlight beams off low cloud cover. The target must be visible to the gunner. The techniques of daylight firing are employed.

53. Field Firing

a. Field firing differs from range firing in that it is not a part of gunner qualification course. It is normally conducted in connection

with the Army Training Programs (ATP's) and Army Training Tests (ATT's) being followed by the organization. Field firing is part of a tactical phase of training after the members of the squad have been trained and the gunner qualified.

b. In field firing the squad will employ the methods learned in crew drill; the platoon leader and squad leader will pay particular attention to positions.

c. The platoon leader controls the fires of the platoon in keeping with the situation. Normally, he delegates this authority to the squad leaders except when firing massed fires.

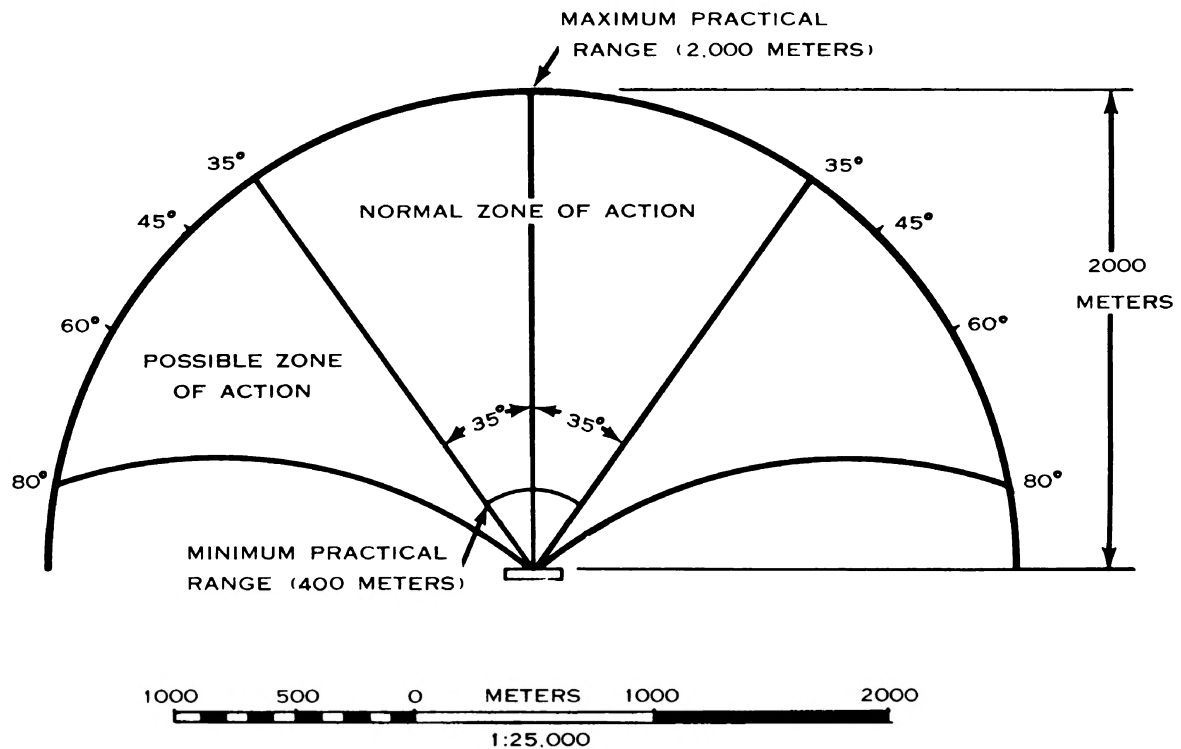

Figure 27. Operational zone of action (schematic).

Section VI. METHODS OF EMPLOYMENT

54. Defensive Operations

a. ENTAC Role. In the defensive role the ENTAC is primarily used to defeat enemy armor. Thus employed, the squads of the antitank platoon must be emplaced well forward and mutually supporting where possible. The squads should be utilized to cover the most likely avenues of approach for enemy armor. In the defense, the antitank platoon may be placed in general support, direct support, or attached to the rifle companies. Generally speaking, because of logistical support, the antitank squads will be attached when in a defensive situation.

b. Defensive Planning. When the battalion is in a defensive position, antitank platoon leaders should give primary consideration to the method of launch to be used. Factors which affect that decision are based on mission, enemy, terrain, and troops. The platoon leader gives guidance to the squad leaders.

- (1) In the ground method, the deployment of the ENTAC missile is limited only by the ingenuity of the squad, based on its particular mission. Consideration should include avenues of approach, obstacles, field of fire, and cover and concealment of personnel and missiles. In most cases the heavy method of launch would be used or some modification thereof. Ideally, the gunner should be forward with the missiles launched from a defilade position to his rear (fig. 28).
- (2) Another consideration should be to employ some missiles from the primary position, and others from a supplementary or alternate position, based on avenues of approach into the squad's sector. Consideration would be based again on mission, enemy, troops, and terrain in determining how to em-

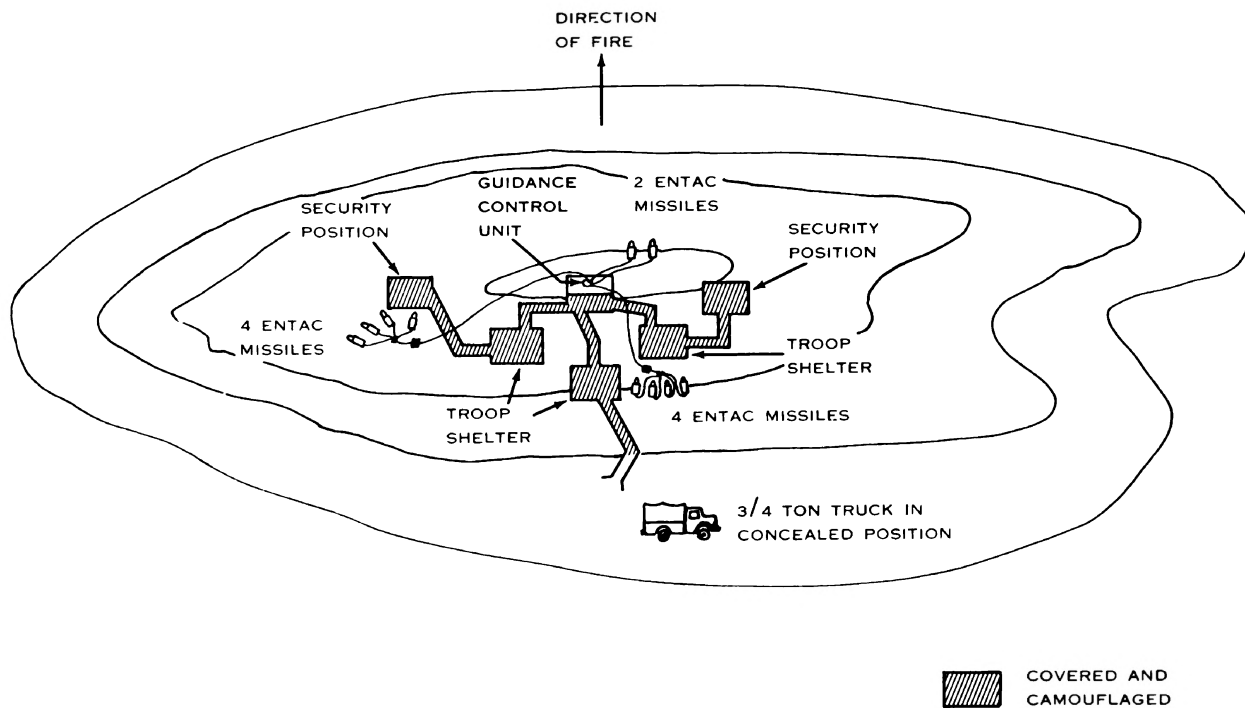

Figure 28. Squad position (schematic).

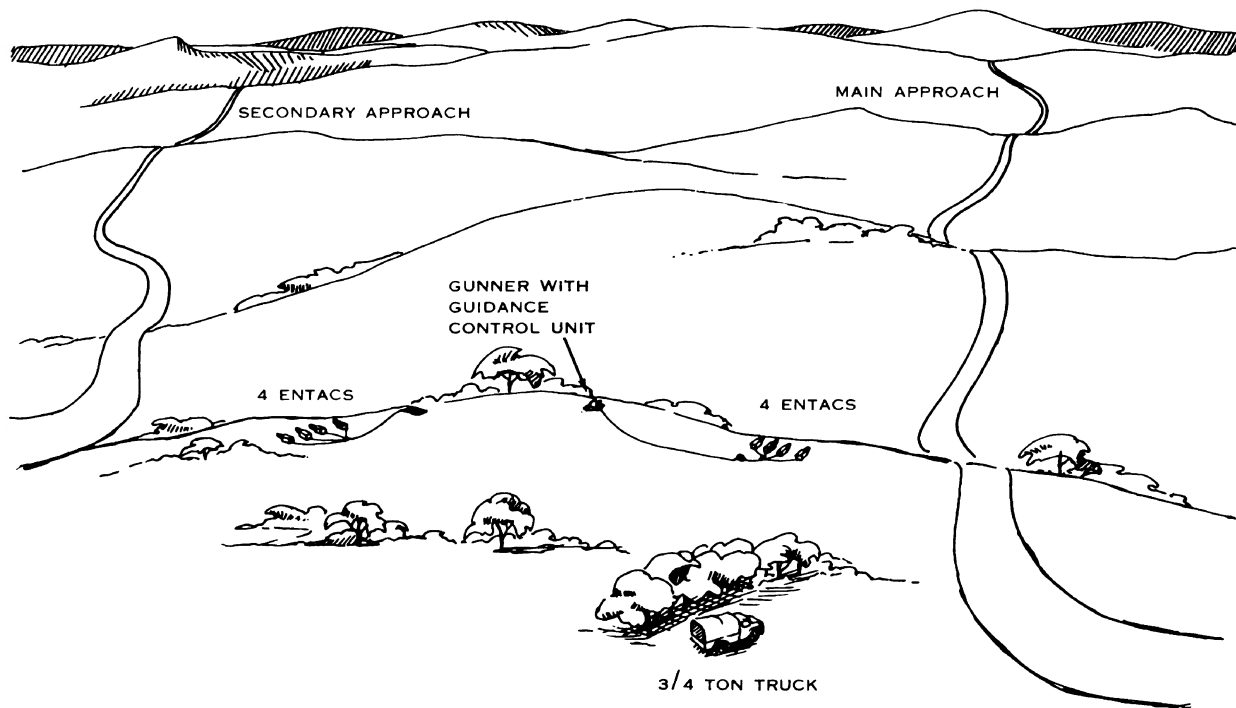

Figure 29. Primary and supplementary positions (schematic).

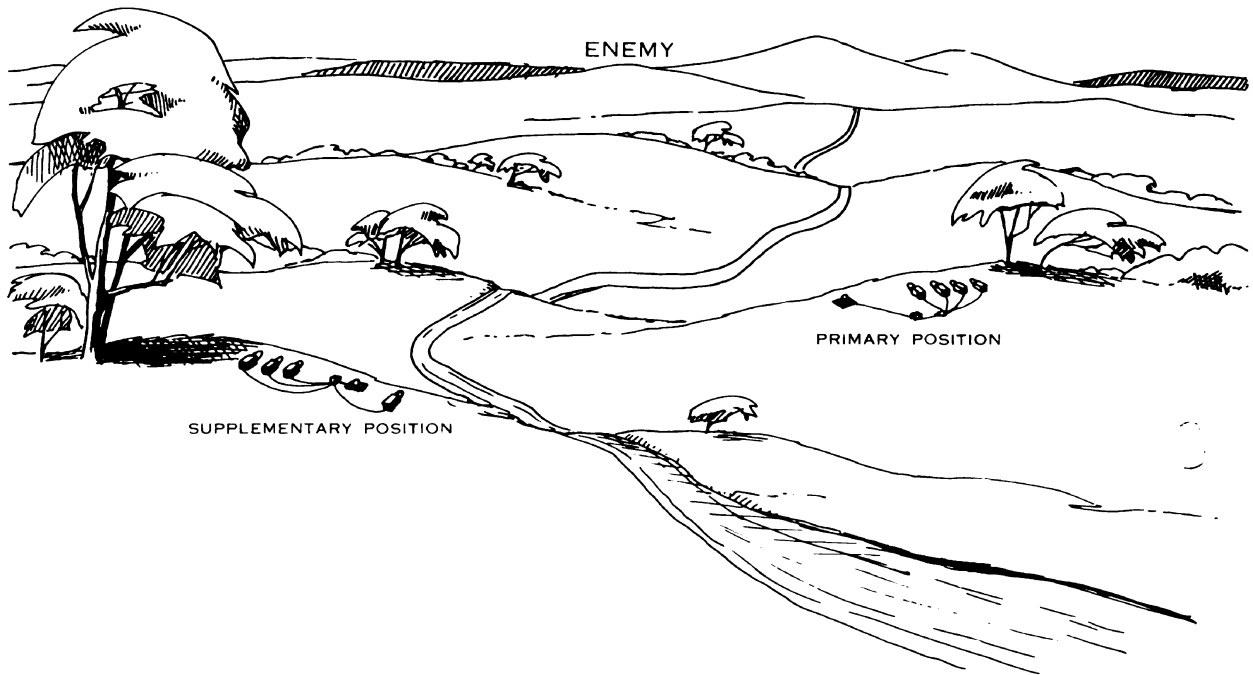

Figure 30. Covering two approaches (schematic).

ploy the squad. In any situation where the missiles are split, consideration must be given to insuring that the gunner can displace from the terminal end of one 100-meter cable to the other, as there is only one guidance control unit organic to the antitank squad. A split in the missile array would be used when the 100-meter cables are not adequate to cover the required sector (figs. 29 and 30).

c. *Emplacements.* The ENTAC missile system is emplaced, fortified, and improved as time permits. In all cases where the antitank squad is dismounted, maximum attention, in accordance with the mission, should be concentrated on concealing the location of the squad and missiles, prior to, and if possible, after launching a missile.

(1) If time permits, every missile should

be emplaced to prevent damage to the missiles, cables, or other parts of the system. Care must be taken, however, to insure mask clearance and that camouflage will not foul the missile when it is launched. The simplest way to camouflage a missile is to take advantage of existing vegetation, natural terrain features, or manmade objects (fig. 31).

(2) The use of existing features is again limited only by the imagination and time of the squad members. The factors that must always be kept in mind are—that the missile must have mask clearance and that the launching container is securely anchored to prevent it from flipping and breaking the guidance wires.

(3) For more permanent installation, dig

emplacements for the ENTAC and bury the cables from the guidance control unit to the various missiles. This will provide limited protection from small arms or artillery fire. Keep the principles of camouflage in mind when digging missile emplacements. Particular attention should be given to disposing of the soil from any digging, and any exposed diggings should be camouflaged, lest the whole network be exposed to aerial observation. Regardless of emplacement method, the same rules apply as to mask clearance and proper anchoring of the launching container. For use in snow, sand, or mud, sandbags, timber, or other available material can be used to construct an emplacement (fig. 32).

- (4) The emplacements previously discussed are considered to be the heavy method of launch, with the missile in defilade on the reverse slope from the gunner. For the light method of launch, the missiles may or may not be in defilade (fig. 33).
- (5) When the missile is emplaced on the forward slope, the missile as well as the cable must be camouflaged. Overhead protection can be improvised from boards, metal, or any other available material.

55. Personnel Shelters

a. Consideration for crew protection is the same as for any crew-served weapon. When the squad is dismounted the primary concern is to

VEGETATION



CULVERT



BATTLEFIELD WRECKAGE



BUILDINGS

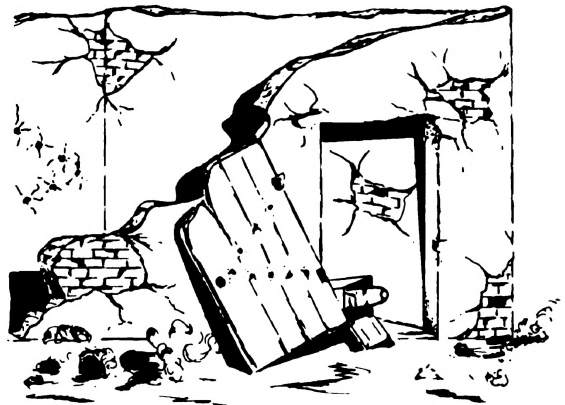
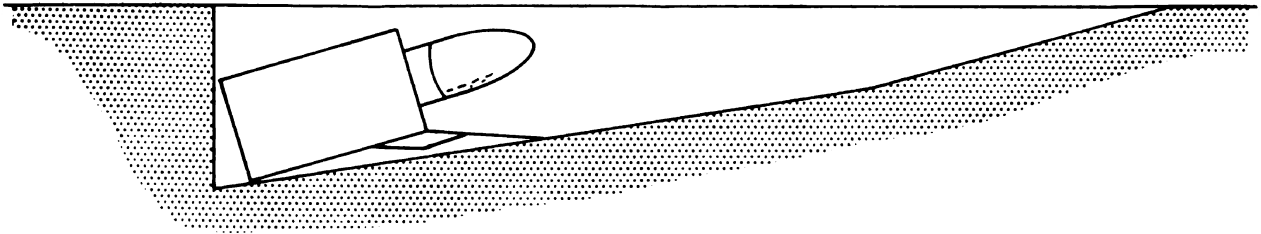

Figure 31. Missile concealment.

NORMAL CONDITIONS

SIDE



CAMOUFLAGE

TOP

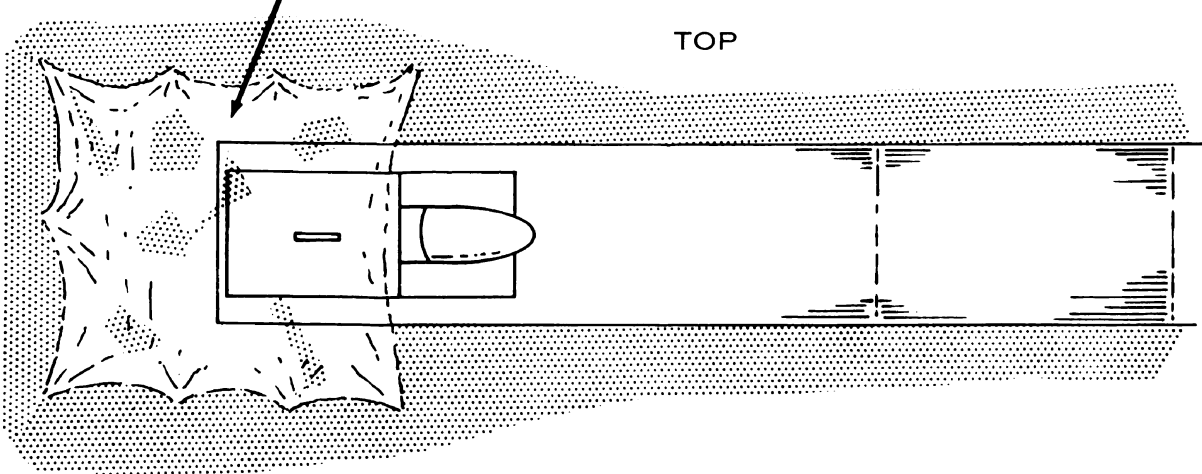

MUD, SNOW, AND SAND

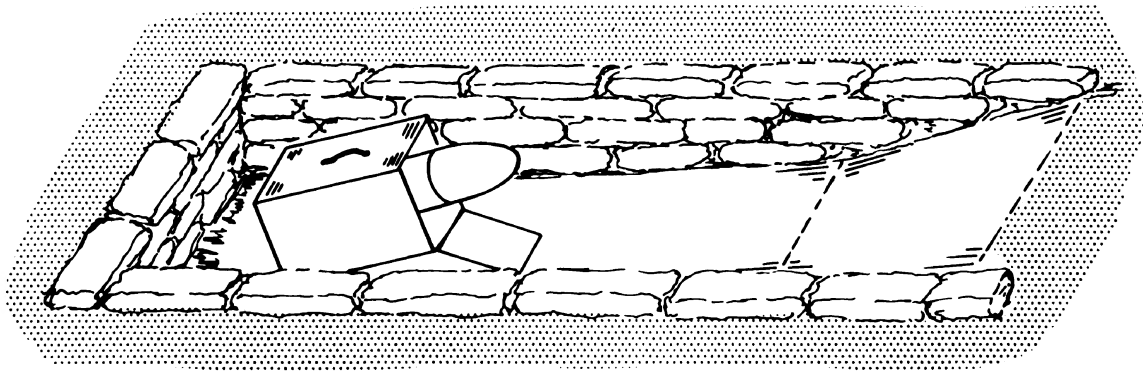

EMPLACEMENT IS THE SAME AS UNDER NORMAL CONDITIONS EXCEPT IT IS REVETTED.

Figure 32. Missile emplacements (schematic).

place the gunner where he can observe the particular sector assigned. The squad leader must place himself where he has the best control of his squad. Individual foxholes are dug for security, flanking the gunner and positioned missiles. The gunner must insure that he can rotate the guidance control unit to any portion of the sector on an approximate azimuth with the missiles to be launched (fig. 34).

b. Once the gunner has dug his emplacement he should place out aiming stakes which correspond to the number and azimuth of the missiles emplaced. The cables leading into the guidance control unit may become tangled and cause trouble. To prevent the cables from tangling, and inhibiting traverse of the guidance station, rear elevating rods from expended missiles can be used by threading the lead-in

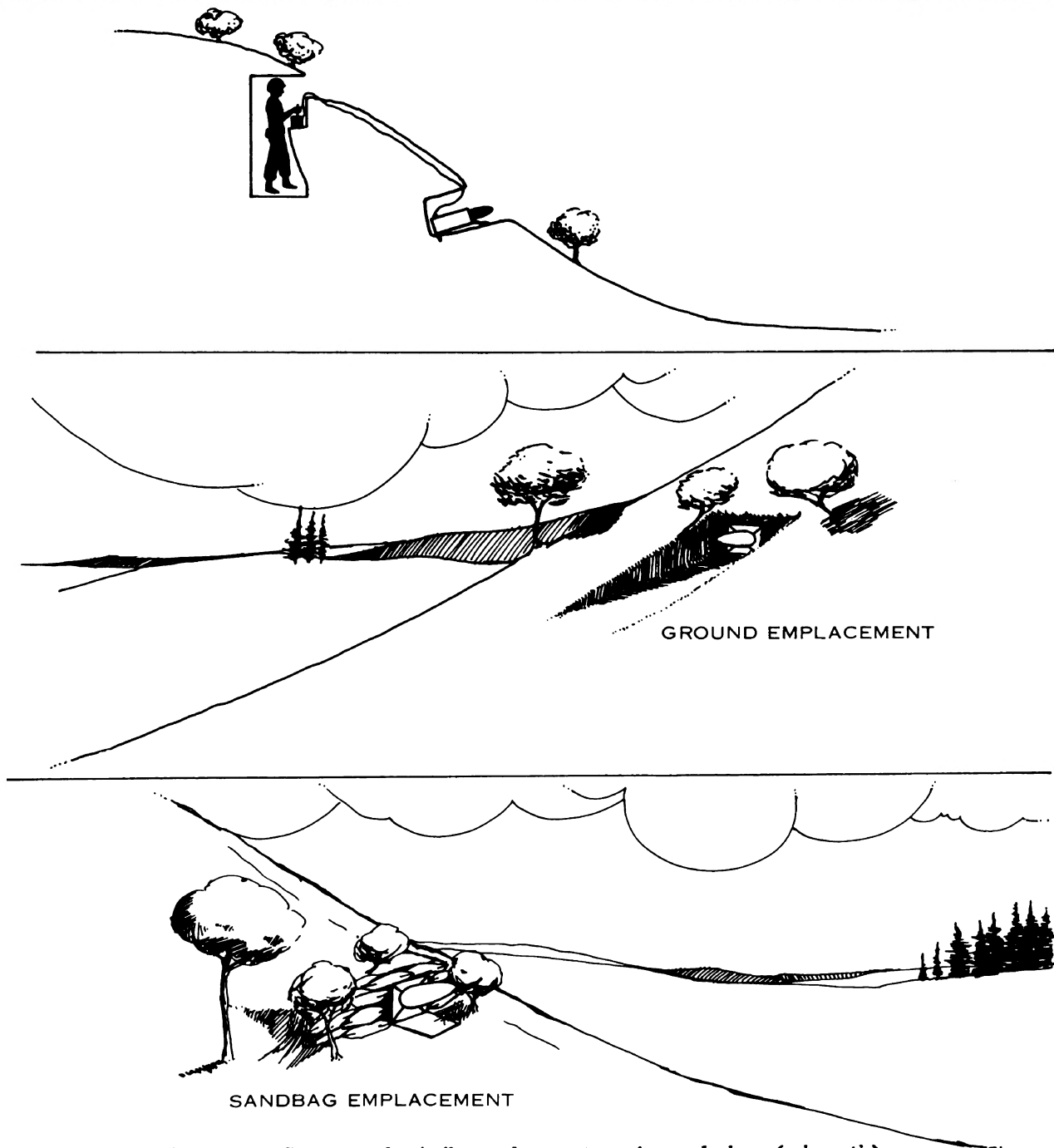

Figure 33. Gunner and missile emplacement on forward slope (schematic).

cables through the hooked end. The stakes are then driven into the ground next to the gunner's position (fig. 35).

c. In the event that time does not permit digging of a foxhole, a hasty shelter may be dug which will give the gunner a limited degree of protection. Here also, the gunner must insure that in a prone position he can observe his assigned sector. In addition, the gunner should insure that he can actually operate the control stick from the prone position (fig. 36).

d. Concrete or other type bunkers can be utilized by the gunner. Upon occupation, the gunner should insure that he has adequate observation through an aperture. The missile should be connected with the 100-meter cable(s) and enter the bunker through the entrance, and not the aperture. Care should be taken to anchor the cables to prevent their being damaged.

56. Squad Positions

The antitank squad will organize its position depending on its particular location in the battalion zone. Generally, the squad leader should try to develop all-round security within his squad's area. Squad members dig individual

positions and develop them as time permits. Connecting trenches and four-man troop shelters are dug if time permits (fig. 37). The squad leader should integrate his squad with any unit in whose sector he is operating.

57. Ambushes

The antitank squad can be utilized in ambush-type missions. This would usually be done in conjunction with some other unit, such as a rifle platoon, or battalion task force. The ENTAC missile can be utilized to destroy the lead vehicle in an armored column, and/or the trailing vehicle; or some other predesignated vehicle in the column. The gunner should be positioned where he can engage the lead vehicle or any other vehicles designated (fig. 38).

58. Barriers

a. Because of its lightweight and size, the ENTAC is particularly useful in denial operations, such as roadblocks. The ENTAC is utilized to cover the roadblock and supplement other covering fires. It is used to engage targets, mainly armor, that would be used to support breaching operations (fig. 39).

b. In addition, the antitank squad can be

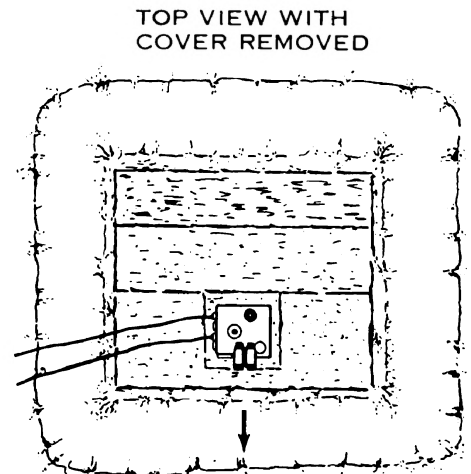
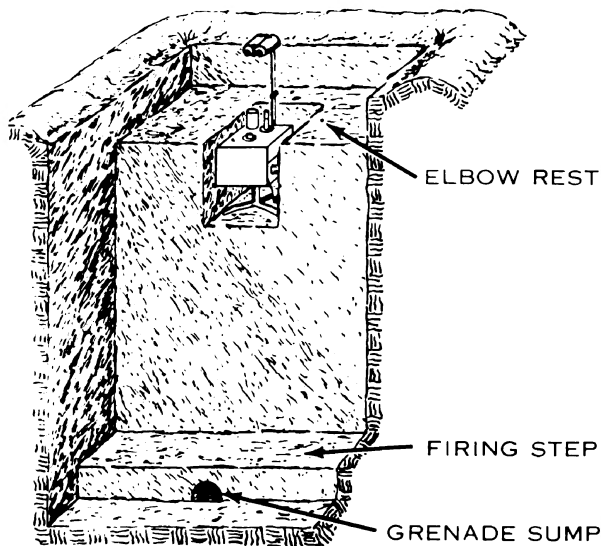

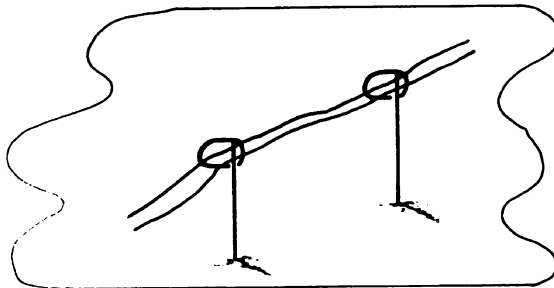
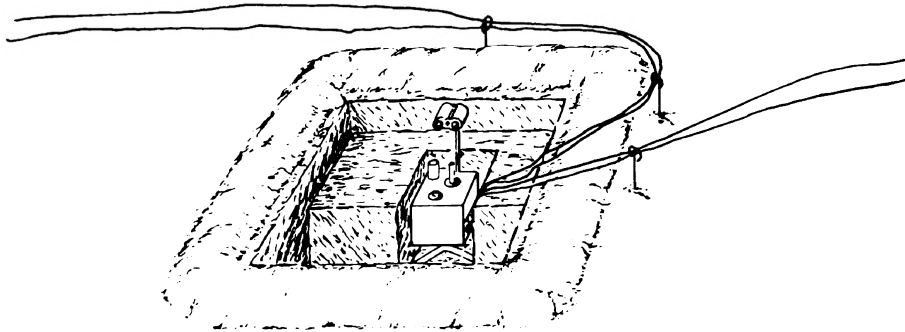
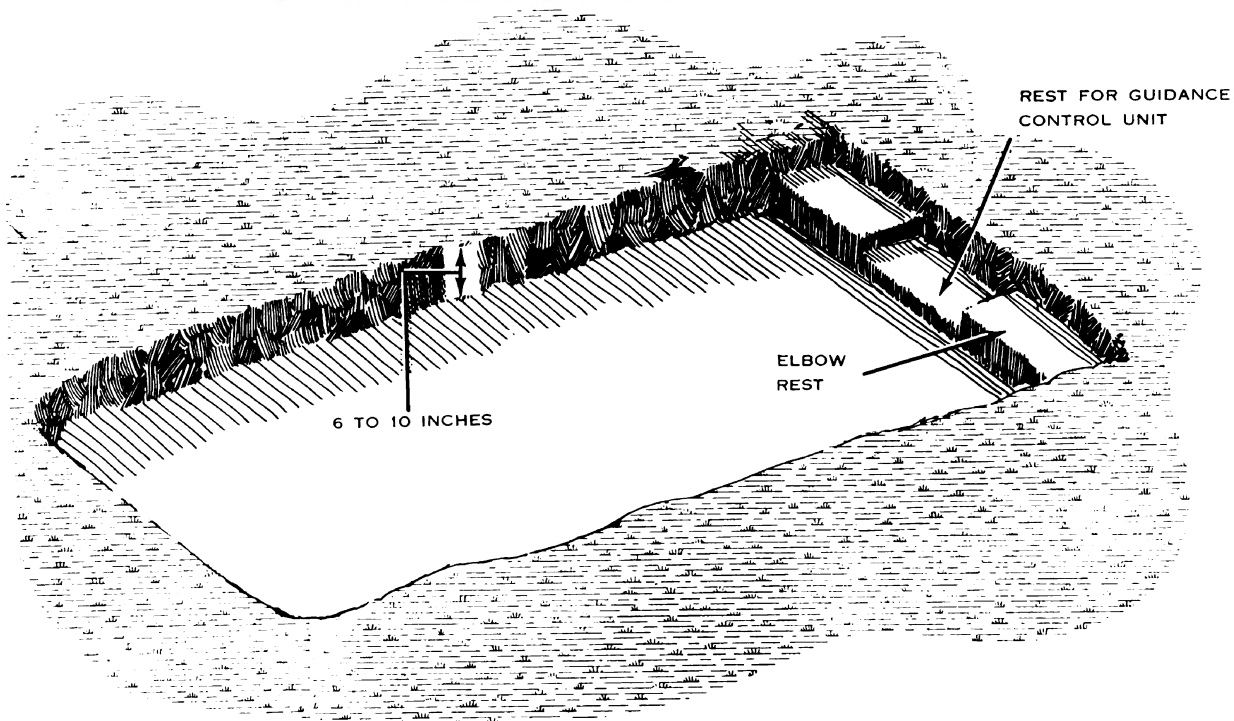

Figure 35. Use of elevating rods to anchor cables (schematic).



NOTE: ACTUAL DIMENSIONS DEPENDS ON SIZE OF GUNNER

Figure 36. Prone position (schematic).

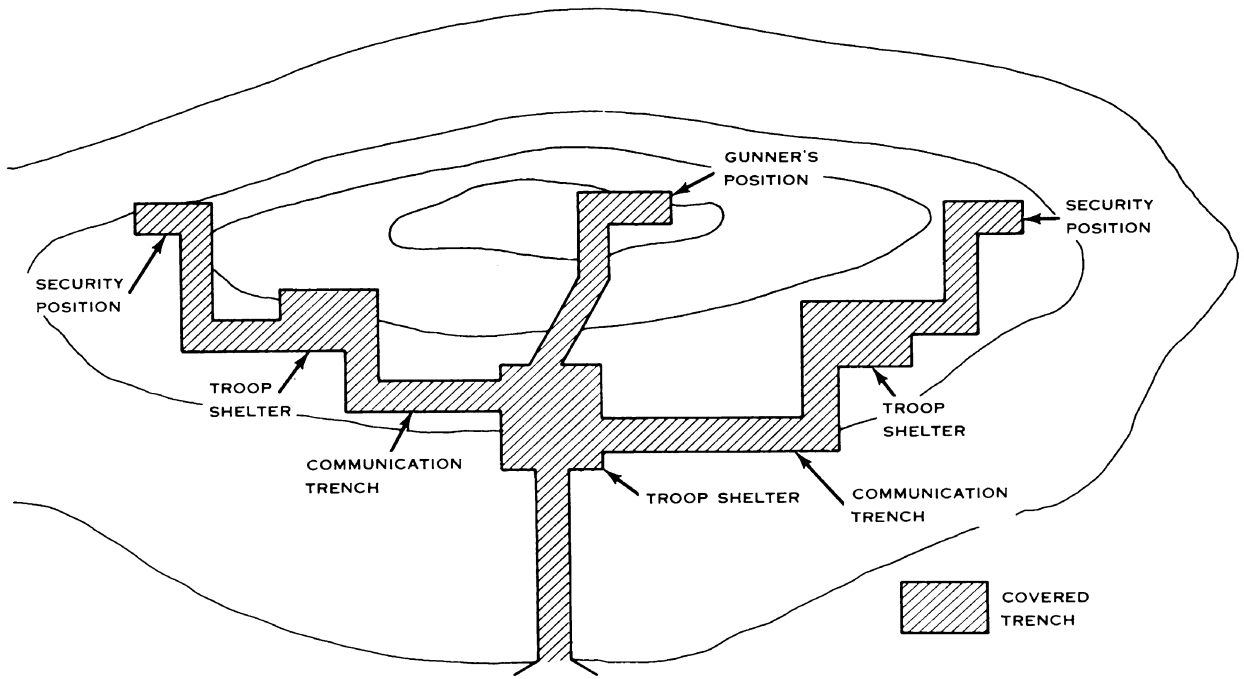

Figure 37. Squad shelters (schematic).



Figure 38. Ambush site (schematic).

used to cover gaps in minefields and other protective barriers.

- (1) Additional uses: due to its small size, the ENTAC missile is particularly useful in built-up areas, especially when an armor threat exists. The gunner can be offset in a building, or some other structure, where he can observe and control his missiles along likely armor approaches. By taking advantage of good observation points, and by using existing obstacles, the antitank squad can cover multiple routes into the squad sector.
- (2) Where more height is needed the gunner can, for example, climb a tree with his guidance control unit and launch and control missiles emplaced on the ground, using the 100-meter cable and selection box.

59. Offensive Operations

a. General. The ENTAC missile system can be used in support of battalion offensive opera-

tions or to support battalion operations of a more specialized nature. In offensive situations the antitank platoon can be used in general support, direct support, or by attachment. Due to the inherent flexibility of the platoon, in most battalion operations the platoon will be utilized in general support. For more specialized missions one or more squads can be utilized in direct support or attachment.

b. Offensive Planning. Squad personnel actions prior to attack are the same as for any other unit, in following troop leading procedures in the assembly area. Vehicles and missiles should be checked, in addition to all guidance equipment, to insure proper functioning. Reconnaissance, both map and terrain, should be made with particular attention to selection of firing positions and armor approaches along the planned route of advance. Particular attention should be given to logistical support, mainly resupply of missiles and rations to the squads.

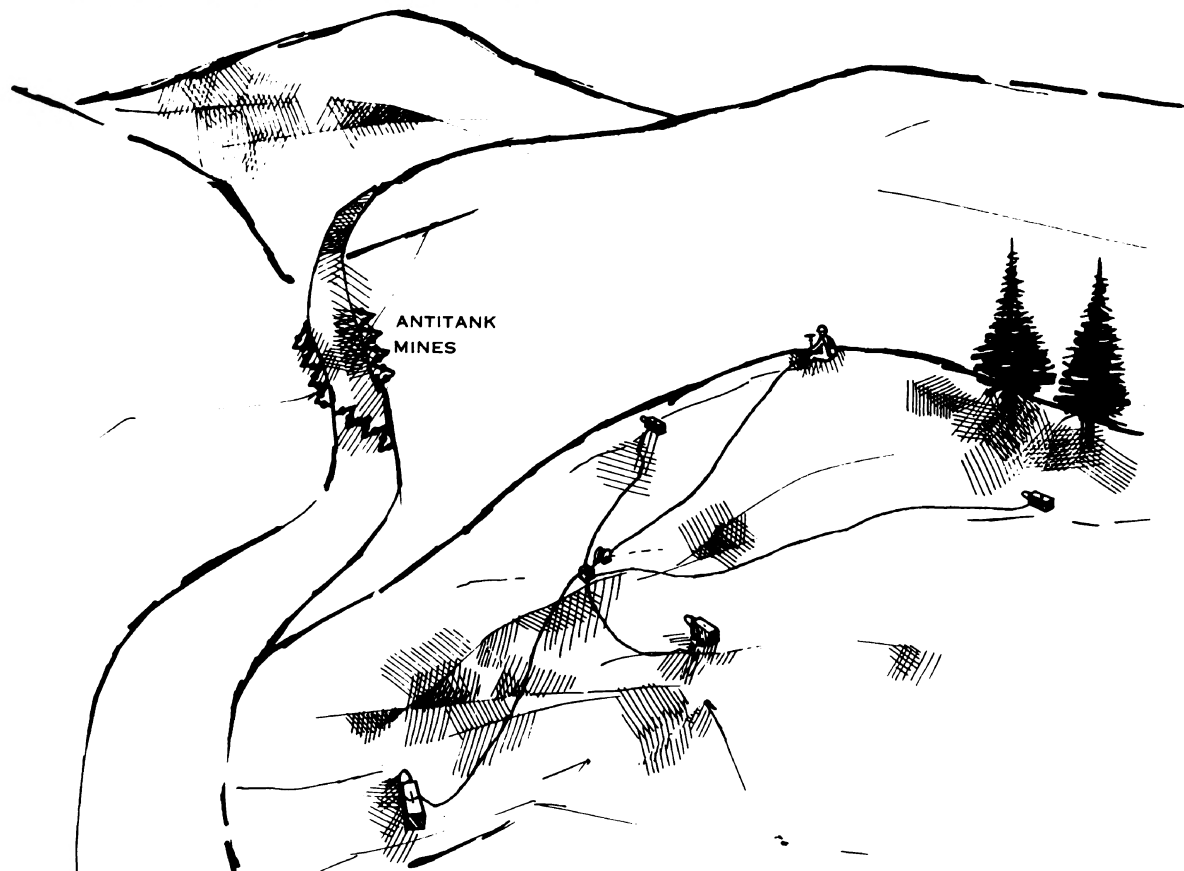

Figure 39. Denial operation (schematic).

c. Ground Method. In foot mobile operations, where an armor threat is not a consideration, the antitank squads may be dismounted to support the attack against fortified positions. In this case, one or more squads may be dismounted and move with the assaulting rifle companies. For short distances the ENTAC missile may be carried by the carrying strap, but for longer distances a packboard (fig. 44) should be used. To support a rifle company the ENTAC squad should travel well forward in the march column. The squad displaces to a flank of the company to support the attack on the objective. The squad would engage known point targets and engage any armor, if it should appear. Another alternative is for the squad to drop off at a good supporting position. When using this method of employment the limita-

tion and danger in firing overhead fire must be kept in mind. The antitank squad displaces to the objective after it has been secured. When the antitank squad is dismounted there is a definite resupply problem, thus this method should be used only when there is no possibility of using the organic vehicles. When dismounted, at least one driver should be left with the vehicles, and preferably two. The vehicles remain under the control of the platoon sergeant who insures they join the squads at the soonest possible time.

d. Airmobile Method. A possible method of equipment transportation is the use of medium or heavy cargo helicopters. Missile resupply can also be accomplished by helicopters until such time as the resupply vehicle can join the squad.



1 Missile equipment for light method of launch and parachutist adjustable equipment bags

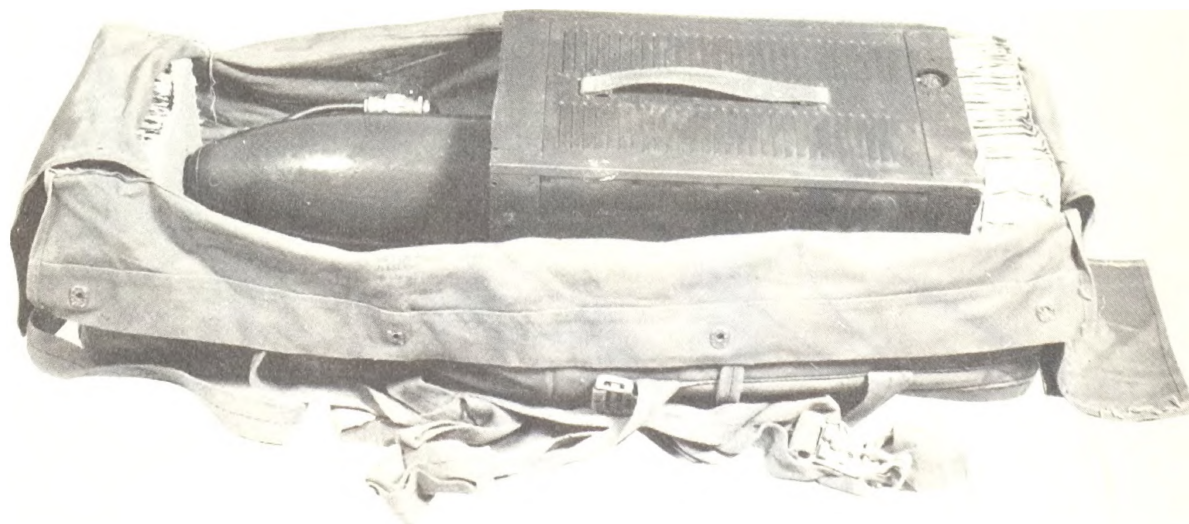

2 Missile packed in equipment bag

Figure 40. Airborne operations.

60. Special Operations

a. Airborne Assault. For use in airborne operations, the antitank squad can jump the equipment required for the light method of launch, with the vehicles being air-dropped with a resupply of missiles. Prior to the arrival of the heavy drop, the squad employs the light method of launch. After the heavy drop is made, the squad leader takes the squad, minus the gunner, to recover the vehicle and ammunition on the heavy-drop pallets. The missiles and guidance equipment are jumped in parachutist adjustable equipment bags, equipped with a lowering strap (fig. 40).

b. Arctic Operations. Arctic operations are similar to airborne operations due to lack of vehicular mobility. For cross-country movement, the antitank squad can break the equipment into skiloads or use towed sleds. Resupply may be effected by arctic vehicles or airdrop.

c. Raids. The ENTAC is particularly useful in raid-type missions. There is no comparable weapon that combines its advantages of lightweight and high destructive power. In raid-type missions the squad, or part of a squad, can carry all the necessary equipment on packboards (fig. 41). The five-man squad can carry three missiles while part of a squad (four or three men) can carry only two missiles.

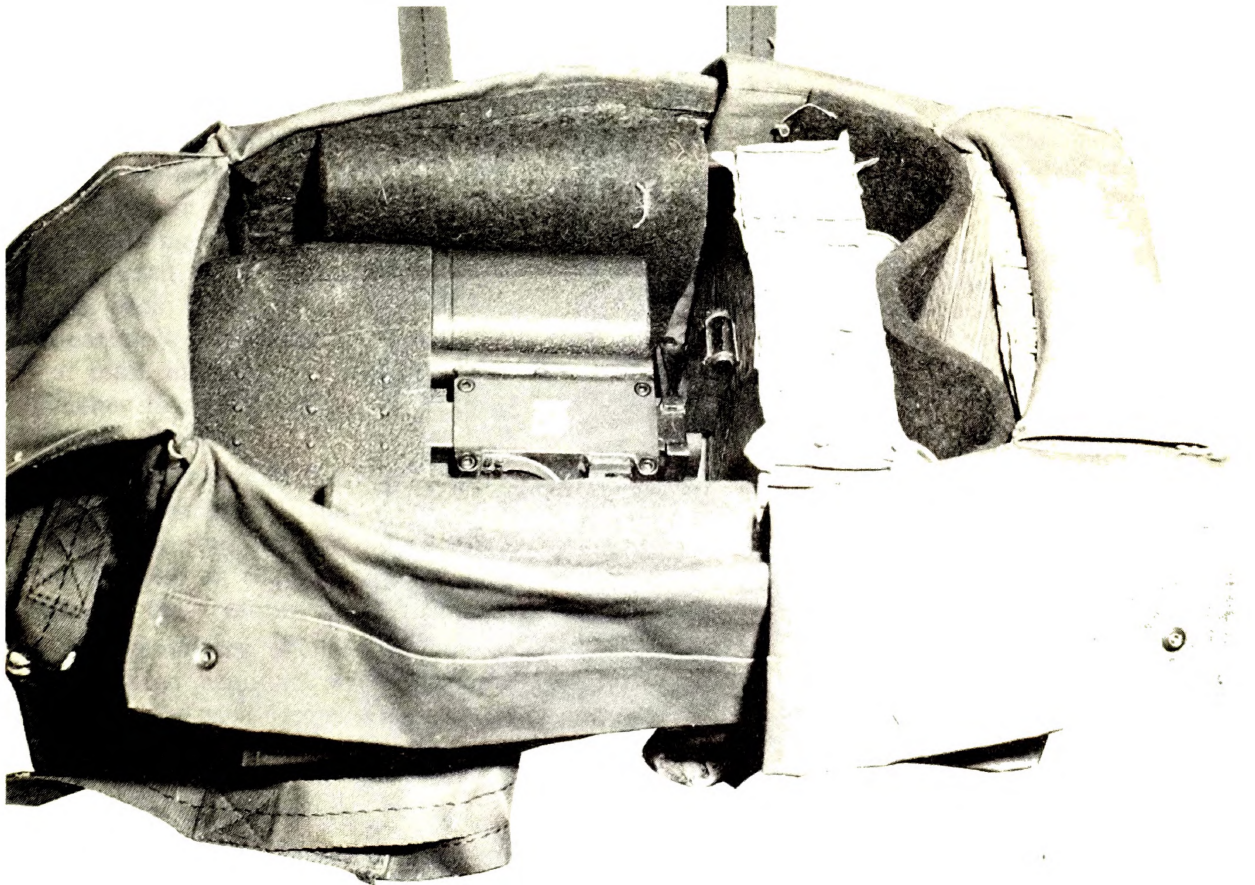

3 Guidance control unit packed in bag

Figure 40—Continued.

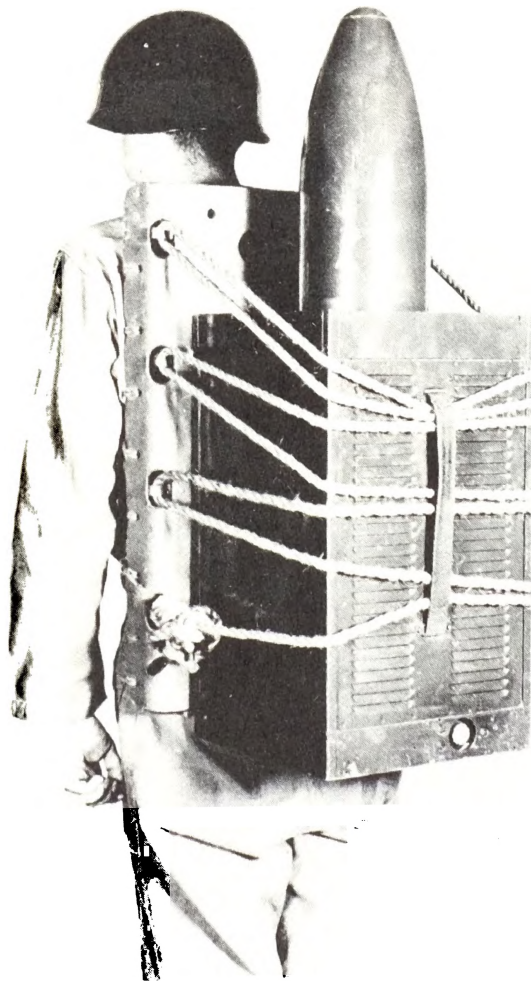

Figure 41. Missile on packboard.

CHAPTER 5

ADVICE TO INSTRUCTORS

61. General

a. Instructors and assistant instructors presenting training on the ENTAC antitank guided missile system must have a thorough knowledge of all aspects of the system as well as knowledge of certain subjects to be integrated during missile training.

b. As training progresses, squad members should be cross-trained in each area of responsibility. This promotes teamwork and insures that each man can perform the duties of the other squad members.

c. All gunnery candidates receive instruction on the simulator through the 20th period. At this time one-third of the candidates are eliminated based on the higher number of errors. The remaining candidates continue simulator training until range firing and then fire four missiles each. After firing four missiles a determination will be made as to which gunners ($\frac{1}{3}$ of total number) will continue to fire until proficiency is attained, firing no more than six additional missiles.

d. A student should not train on the simulator for more than 15 minutes each hour or he may suffer eye fatigue. When the student is not training on the simulator he should not remain in the training room.

e. The simulator should be operated in a well-ventilated, semidark area so there will be no glare on the oscilloscope screen and the blue spot of light can be seen easily.

62. Program of Instruction

a. The following suggested program of instruction is considered adequate for both unit and individual replacement training:

<i>Hours and Type Instruction</i>	<i>Scope</i>
1C-----	Outline of the training program covering number of hours and type of instruction.

See note and legend at end of program.

<i>Hours and Type Instruction</i>	<i>Scope</i>
5CDPE----	Description, nomenclature, and functioning of the missile and its guidance equipment. Platoon organization, employment, maintenance, and malfunctions and immediate action.
1CD-----	Nomenclature, capabilities, characteristics, maintenance, and operation of the S-58 training simulator and its auxiliary equipment.
2CDPE----	Critique and evaluation of simulated missile flight on the S-58 training simulator.
6CDPE----	Crew drill on the light and heavy method of launch to include commands, individual duties, preparation and installation of the missile for launch, and use of the test equipment.
46CDPE---	Gunner training with the S-58 training simulator. This block of instruction is presented in 184 15-minute periods. One hundred and sixty of these periods will be accomplished prior to range firing.
4CPE-----	Techniques of fire with the ENTAC system to include range determination, target acquisition, fire commands, time/space factors, night firing, range cards, and preparation of missile positions.
12PE-----	Performance of first echelon maintenance on the vehicles, guidance equipment, and simulators used in the training program.
1CPE-----	Orientation on the range, range safety, and live firing to be accomplished.
6CDPE----	Range firing consisting of two missiles per gunner candidate. First missile to be fired at stationary target, range of 1500-1900 meters; second to be fired at stationary target, range of 1300-1800 meters.
7CDPE----	Range firing to consist of two missiles per gunner candidate. Third missile to be fired at moving target, range of 1000-1300 meters. Fourth missile to be fired at moving target, range of 1000-1300 meters.

Hours and Type
Instruction

Scope

5CPE-----Range firing to consist of three missiles per gunner candidate. Fifth missile to be fired at moving target, range of 1000-1300 meters; sixth missile to be fired at moving target, range of 1000-1300 meters; seventh missile to be fired at moving target, range of 800-1000 meters.

Hours and Type
Instruction

Scope

4CPE-----Range firing to consist of three missiles per gunner candidate. Eighth missile to be fired at stationary target, range of 1000-1200 meters; ninth missile to be fired at stationary target, range of 1200-1600 meters; tenth missile to be fired at stationary target, range of 600-1000 meters.

Note. Techniques of fire and range orientation must be completed prior to range firing.

LEGEND: C—Conference, D—Demonstration, PE—Practical Exercise.

b. Some examples of subjects suitable for in and individual replacement training:

Platoon tactical training-----Battalion organization; employment of the antitank platoon in offensive, defensive, and retrograde operations; antitank platoon operations.
Infantry communications-----Principles of radiotelephone procedures, message writing, wire splicing, wire laying, and field expedient. Use of the SSI and SOI. Operations and use of the AN/PRC-25 and AN/VRC-47 radios; operation and use of the switchboard SB-993/GT, telephone set TA-312/PT, wire reel RL-27 and RL-159/U, and reel equipment CE-11.
Maps and compass training-----Basic map reading techniques and use of the compass in day and night operations.
Field fortifications-----Preparation of positions and emplacement of personnel and missile equipment.
Generator, 5KW-----Use of the generator in field operations with the S-58 training simulator.

63. Organization

a. *Officer in Charge of Firing.* An officer in charge of firing is designated by the commanding officer of the unit firing on the range. It is desirable that this officer be the senior officer on the range. This officer, or his assistant, will be present during all firing. He is responsible for the proper operation and safe conduct of the range firing.

b. *Ammunition Points.* The principal, or rear, ammunition point should be at least 200 meters from the firing line. The missiles are uncrated and removed from the shipping containers at this point. A forward ammunition point should be located at least 50 meters from the firing line. Only the number of missiles required to replace those on the firing line (never more than four) should be located in the forward ammunition point at any one time.

c. *Firing Line.* Only those personnel required for safety and grading of the missile flight should be on the firing line with the student gunner. The safety officer normally positions

himself near the guidance control unit so that he can rotate the safety switch to the safe "S" position, if necessary. Two flight critique (grading) personnel are required for each missile flight. The student gunner will be critiqued immediately after each missile flight. The safety officer, equipped with a pair of binoculars, will rule on target hits.

d. *Missile Emplacement.* The safety officer will supervise the emplacement of all missiles. Normally, when firing from the ground, only two missiles will be positioned. Warheads are attached to the finned body, on order of the safety officer, after the launching container has been properly anchored.

e. *Missile Firing.* Prior to firing a missile, the student gunner receives an orientation on the missile to be fired and the target to be engaged. He is also critiqued on any errors made during previous missile flights. Only one missile is fired at a time on the range. It is best to have a student gunner fire only one missile and then take a break before he fires again.

APPENDIX REFERENCES

- AR 385-40 Accident Reporting and Records.
- AR 385-62 Firing Guided Missiles and Heavy Rockets for Training, Target Practice, and Combat.
- AR 385-63 Regulation for Firing Ammunition for Training, Target Practice, and Combat.
- AR 700-1300-8 Malfunctions Involving Ammunition and Explosives.
- FM 7-10 Rifle Company, Infantry and Airborne Battle Groups.
- FM 7-11 Rifle Company, Infantry, Airborne Infantry, and Mechanized Infantry.
- FM 7-15 Infantry, Airborne Infantry, and Mechanized Infantry, Rifle Platoons and Squads.
- FM 7-20 Infantry, Airborne Infantry, and Mechanized Infantry Battalions.
- FM 7-30 Infantry, Airborne, and Mechanized Division Brigades.
- FM 21-5 Military Training.
- FM 21-6 Techniques of Military Instruction.
- FM 21-30 Military Symbols.
- TC 23-2 SS-10 Guided Missile (Infantry and Armor Units).
- TM 3-220 Chemical, Biological and Radiological (CBR) Decontamination.
- TM 9-1400-455-12 Operator and Organizational Maintenance Manual; ENTAC Antitank Guided Missile System.
- TM 9-1400-455-35 Field and Depot Maintenance Manual; ENTAC Antitank Guided Missile System.
- TM 9-1400-455-35P/1 Field and Depot Maintenance, Repair Parts and Special Tool Lists; ENTAC Systems.
- TM 9-1900 Ammunition, General.
- TM 9-1903 Care, Handling, Preservation and Destruction of Ammunition.
- TM 9-6920-455-12 Operator and Organizational Maintenance Manual:
 Guided Missile Flight Control Training Set 10119920 (Simulator S-58) (ENTAC Antitank Guided Missile System).
- TM 9-6920-455-35 Field and Depot Maintenance Manual: Guided Missile Flight Control Training Set 10119920.
- TM 9-6920-455-35P Field and Depot Maintenance, Repair Parts and Special Tool Lists; Guided Missile Flight Control Training Set 10119920.
- TOE 7-16E Headquarters and Headquarters Company, Infantry Battalion.
- TOE 7-36E Headquarters and Headquarters Company, Airborne Infantry Battalion.
- TOE 7-46E Headquarters and Headquarters Company, Mechanized Division, Mechanized Infantry Battalion.

INDEX

	Paragraphs	Pages		Paragraphs	Pages
Assembly:			Guidance control unit:—continued		
Attaching warhead to body	6	6	Maltese cross	10	23
Removing from shipping container	6	6	Nickel cadmium battery	10	23
Battery charger	14	32	Safety switch	10	23
Cables, reel assembly	12	31	Selector dial	10	23
Circuit test	41	59	Signal generator	10	23
Circuit test set:			Target orientation	10	23
Cable connections	13	32	Voltmeter	10	23
Maltese cross indicator	13	32	Guidance equipment	3	2
Pitch, yaw switch	13	32	Instructors, advice to:		
Test button	13	32	Organization:		
Components, missile:			Ammunition points	63	82
Finned body	8	15	Firing line	63	82
Warhead	8	15	Missile emplacement	63	82
Crew drill:			Missile firing	63	82
Duties	37	51	Officer in charge	63	82
Organization	38	51	Program of instruction	62	81
Data, missile	3	2	Launching container	15	33
Decontamination	26, 27	40	Launching methods:		
Defensive operations:			Heavy method	40	56
Ambushes	57	74	Light method:		
Barriers	58	74	Action	39	52
Emplacements	54	68	Cease fire	39	32
ENTAC role	54	68	Crew drill	39	52
Personnel shelters	55	71	Examine equipment	39	52
Planning	54	68	General	39	52
Squad positions	56	74	Out of action	39	52
Description, missile	3	2	Prepare to fire	39	52
Destruction:			Launching, preparation for:		
Guidance equipment	29	41	Clearance	7	9
Missiles	30	41	Elevation	7	9
Simulator	31	41	Ground conditions:		
When to destroy	28	40	Hard	7	9
Field firing	53	67	Normal	7	9
Fire commands:			Soft	7	9
Cease fire	49	65	Malfunctions; missile, guidance equipment:		
Initial	49	65	Guidance equipment:		
Massed fire	49	65	Electrical	20	37
Functioning:			Mechanical	20	37
Battery, activation of	9	17	Missile:		
Guidance system	9	17	Electrical	21	37
Gyroscope assembly	9	17	Mechanical	21	37
Propulsion system	9	17	Night firing	52	66
Warhead	9	17	Offensive operations:		
Guidance control unit:			Airmobile method	59	77
Battery test	10	23	Ground method	59	77
Cable connections	10	23	Planning	59	77
Control stick	10	23	Range cards:		
Firing switch	10	23	Preparation	51	66
Flare cutoff switch	10	23	Purpose	50	66

	Paragraphs	Pages		Paragraphs	Pages
Range determination:			Special operations:		
Binoculars	46	63	Airborne assault	60	79
Estimation by eye	46	63	Artic operations	60	79
Maps, photomaps	46	63	Raids	60	79
Rangefinders	46	63	Storage, maintenance:		
Range firing sequence	42	59	Guidance equipment	23, 25	38, 40
Safety precautions:			Missile	22, 25	38, 40
General	43	60	Simulator	24, 25	39, 40
Handling, assembling, firing	43	60	Time/space factor:		
Transporting	43	60	Example	47	65
Selection box	11	31	Speed of target	47	65
Shipping container	16	34	Training, preparatory:		
Simulator	4	5	Sequence, squad members	33	43
Simulator S-58:			Simulator sequence	35	43
Computer chassis	17	34	Warheads	3, 6,	2, 6,
Operation	18	36		8, 9	15, 17
Oscilloscope chassis	17	34			
Power input chassis	17	34			
Power supply chassis	17	34			

By Order of the Secretary of the Army:

EARLE G. WHEELER,
General, United States Army,
Chief of Staff.

Official:

J. C. LAMBERT,
Major General, United States Army,
The Adjutant General.

Distribution:

Active Army:

DCSPER (2)
ACSI (2)
DCSLOG (2)
ACSFOR (2)
CORC (2)
COA (1)
CINFO (1)
TIG (1)
TSG (1)
TJAGSA (1)
PMGS (5)
MFSS (5)
USA Ord Sch (150)
USAES (25)
USATSCH (5)
USASCS (5)
USACMLCSCH (5)
USASESCS (5)

USACHS (1)
USCONARC (20)
CNGB (5)
USACDC (10)
ARADCOM (2)
ARADCOM Rgn (1)
Armies (5)
Corps (3)
Div (10)
Div Arty (5)
Log Comd (1)
Brig (5)
Regt (5)
Gp (1)
Inf Bg (5)
CC (5)
Bn (5)
Co/Btry (5)

NG: State AG (3).

USAR: Same as active army except one copy each unit.

For explanation of abbreviations used, see AR 320-50.

UNIVERSITY OF MINNESOTA



3 1951 D03 425 685 G

FM 23-9 ANTITANK GUIDED MISSILE (ENTAC) — 1964

FM 1-110

DEPARTMENT OF THE ARMY FIELD MANUAL

ARMED HELICOPTER EMPLOYMENT

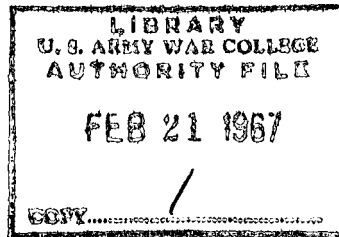

WAR
COPY



HEADQUARTERS, DEPARTMENT OF THE ARMY
JULY 1966

Table II. Range Data.

Item	Subsystem (range in meters)								
	M2	M6	XM3		M22	M5	XM16		
	Type of ammunition								
	7.62mm	7.62mm	2.75-inch rocket		AGM-22B	40mm	7.62mm	2.75-inch rocket	
Old ¹			New ²	Old ¹				New ²	
Maximum range-----	3, 200	3, 200	7, 500	9, 300	3, 500	1, 750	3, 200	7, 500	9, 300
Maximum effective range-----	750	750	2, 500	2, 500	3, 500	1, 200	750	2, 500	2, 500
Minimum employment range-----	NA	NA	300	300	500	300	NA	300	300

¹ Rocket motors over 4 years old.

² Rocket motors less than 4 years old.

Table III. Performance Data.

Item	Subsystem					
	M2	M6	XM3	M22	M5	XM16
Fuze arming distance (meters)-----			187	300	18-37	187
Flight time (seconds)-----			¹ 1.69	22		¹ 1.69
Penetration (inches of armor)-----				20		
Bursting radius (meters)-----					10	
2.75-inch rocket w/6.45-lb whd-----			6			6
2.75-inch rocket w/10-lb whd-----			8			8
Maximum rate of fire-----	550 rds/min each gun.	550 rds/min each gun.	6 pairs of rockets/ sec.	1 per 23 sec.	220 rds/min	550 rds/min each gun and 6 pairs of rockets/ sec.
Maximum acceleration (ft/sec)-----			2,300	600		2,300
Muzzle velocity (ft/sec)-----	2,750	2,750			790 (M384)	
Ammunition capacity-----	1,100 rds	6,700 rds	48 rockets	6 missiles	150 rds	6,700 rds (7.62mm) and 14 2.75-inch rockets.

¹ Rocket motor burnout time.

Table IV. Angular Coverage.¹

Item	Angular limits (degrees)		
	M5	M6/XM16	M2
Outboard (right and left)-----	60	70	None
Inboard-----	NA	12	None
Elevation-----	15	15	9
Depression-----	35	60	None

¹ The XM3 subsystem fires from fixed positions; the XM16 subsystem combines fixed firing of 2.75-inch rockets with flexible firing of the M6; and the M22 subsystem is wire-guided.

b. The weapons are fired, elevated, charged, or made firesafe by the pilot without releasing the

helicopter controls. A pneumatic charger assembly controls the charging and safety operation of each gun, and a trigger switch is used to actuate both firing solenoids. The two M60C machine-guns in this subsystem are capable of being adjusted vertically through an arc of +9°. This is accomplished by the pilot from inside the cockpit. While firing, deflection adjustments are made by turning the helicopter left or right.

c. Total weight for the subsystem with a complete ammunition load is 162.5 pounds.

3. XM3 Helicopter Armament Subsystem

a. The XM3 armament subsystem mounted on the UH-1B helicopter (fig. 13) has been adopted