

UNCLASSIFIED

DST-1110H-163-76



**DEFENSE
INTELLIGENCE
AGENCY**

SMALL ARMS IDENTIFICATION AND OPERATIONS GUIDE— FREE WORLD

APPROVED FOR PUBLIC RELEASE; DISTRIBUTION UNLIMITED

3 FEBRUARY 1984

**THIS COPY IS A REPRINT
THAT INCLUDES CURRENT
PAGES FROM CHANGES 1 AND 2**

UNCLASSIFIED

SMALL ARMS IDENTIFICATION AND OPERATIONS
GUIDE--FREE WORLD

AUTHOR
James F. Kettrick

DST-1110H-163-76-CHG 2

DIA Task PT-1110-01-04L

DATE OF PUBLICATION
3 February 1984

Information Cutoff Date
1 September 1983

This document supersedes ST-HB-07-163-74.

This is a Department of Defense Intelligence Document prepared by the Foreign Science and Technology Center, US Army Materiel Development and Readiness Command, and approved by the Assistant Vice Directorate for Scientific and Technical Intelligence of the Defense Intelligence Agency.

APPROVED FOR PUBLIC RELEASE;
DISTRIBUTION UNLIMITED

(Reverse Blank)



3 February 1984

PREFACE

This guide* is intended to provide information on the identification, physical characteristics, operation and functioning, user maintenance, accessories, and ammunition of free world small arms. No attempt has been made to provide instruction for complete maintenance and repair. This guide does not provide information on US small arms or small arms of Communist origin. The latter weapons are covered in DST-1110H-394-76, Small Arms Identification and Operation Guide--Eurasian Communist Countries

This guide covers, in order, pistols, submachine-guns, rifles, and machineguns. Individual sections provide information on specific weapon models: general information, technical data, operation of the weapon, disassembly and assembly, and functioning of the mechanism and accessories normally used with the basic weapon.

The disassembly and assembly procedures described are limited to those operations required by the user to maintain the weapon properly. Detailed or complete disassembly should not be undertaken because of the danger of lost or broken parts, which would render the weapon unuseable. Major parts (such as bolts and trigger mechanisms) should not be interchanged between weapons; these parts are usually numbered to specific weapons, and their use in other weapons could cause malfunctions.

Pages requiring no changes are reprinted and therefore bear the previous short title and date. Amended and new pages bear the current short title and date. An asterisk () on changed pages indicates new or significantly changed information in the paragraph, illustration, or table so indicated.

Unless otherwise specified, the weapons covered herein should be cleaned and lubricated with the same materials and techniques used for standard US small arms. Special care should be taken to remove the firing residue from the components of the gas mechanism of gas-operated arms.

Many military weapons have "V"-notch rear sights and post front sights. The correct sight picture with this type of sight is identical with that used for the US Pistol, Caliber 45 M1911A1. The front sight is centered in the notch with the top of the front sight level with the top of the rear sight. This sight picture is held at the point where it is desired that the bullet strike. To zero a weapon's sights, move them so that the relative motion of the rear sight is in the same direction as it is desired to move the strike of the bullet. Practical range, as used in this publication, is defined by the US Army Foreign Science and Technology Center (FSTC) as that range at which the average trained rifleman can be expected to hit a man-sized target with approximately 50% of his shots.

Constructive criticisms, comments, or suggested changes are encouraged and should be forwarded to the Defense Intelligence Agency, Washington, DC 20301 (ATTN: DT).

3 February 1984

LIST OF EFFECTIVE PAGES

SUBJECT MATTER	PAGE NUMBERS	DATE
Title Page	None	3 Feb 1984
Preface	iii and iv	3 Feb 1984
List of Effective		
Page	v thru vi	3 Feb 1984
Record of Changes ..	vii (RB)	Dec 1976
Table of Contents ..	ix thru xxv	-----
	ix and x	Dec 1976
	xi and xii	3 Feb 1984
	xiii and xiv	5 Sep 1980
	xv and xvi	3 Feb 1984
	xvii and	
	xviii.1 (RB)	5 Sep 1980
	xix and xx	Dec 1976
	xxi	5 Sep 1980
	xii	Dec 1976
	xxiii thru xxv	3 Feb 1984
List of Illustrations	xxvi thru xxxi	-----
	xxvi	3 Feb 1984
	xxvi.1 (RB)	5 Sep 1980
	xxvii and xxviii	3 Feb 1984
	xxix and xxx	5 Sep 1980
	xxxi and xxxii	3 Feb 1984
List of tables	xxxiii (RB)	Dec 1976
Section I	1 thru 54.16	-----
	1 thru 44	Original
	45 and 46	3 Feb 1984
	47 thru 50	Original
	51 thru 54	3 Feb 1984
	54.1 thru 54.14	5 Sep 1980
	54.15 and 54.16	3 Feb 1984
Section II	55 thru 126.3 (RB)	-----
	55 and 56	5 Sep 1980
	57 thru 75	Original
	76	Dec 1976

SUBJECT MATTER	PAGE NUMBERS	DATE
Section II (Cont) ..	77 thru 79	Original
	80	5 Sep 1980
	81 thru 122	Original
	123 thru 126.3 (RB)	3 Feb 1984
Section III	127 thru 240	-----
	127 thru 136	Original
	137 and 138	3 Feb 1984
	139 thru 172	Original
	173 and 174	3 Feb 1984
	174.1 thru 175	5 Sep 1980
	176 thru 182	Original
	183 and 184	3 Feb 1984
	185 thru 188	Original
	189 thru 192	3 Feb 1984
	193 thru 218	Original
Section IV	219 and 220	3 Feb 1984
	221 thru 238	Original
	238.1 and 238.2	5 Sep 1980
	238.3 thru 240	3 Feb 1984
	241 thru 310	-----
	241 thru 253	Original
	254 and 255	Dec 1976
	256 thru 281	Original
Section V	282 thru 290.2	5 Sep 1980
	291 thru 299	Original
	300 thru 304.2	5 Sep 1980
	305 and 306	Original
	307 thru 311 (RB)	3 Feb 1984
	Distribution List ..	313 and 314
313 and 314		3 Feb 1984
Distribution List ..	315 thru 318	-----
	315 thru 318	3 Feb 1984

RECORD OF CHANGES

CHANGE NUMBER	DATE OF CHANGE	DATE ENTERED	SIGNATURE, RANK/RATE AND ORGANIZATION OF INDIVIDUAL ENTERING CHANGE

(Reverse Blank)



TABLE OF CONTENTS

	<i>Para</i>	<i>Page</i>
PREFACE		iii
SECTION I. PISTOLS		
A. THE 9-MM PISTOLE P1 (WEST GERMANY)		
General	1	1
Technical Data	2	2
Operation	3	2
Disassembly and Assembly	4	3
Functioning	5	5
Accessories	6	7
B. THE 9-MM F.N. BROWNING HIGH POWER PISTOL (BELGIUM)		
General	7	8
Technical Data	8	12
Operation	9	12
Disassembly and Assembly	10	13
Functioning	11	15
Accessories	12	17
C. THE 9-MM BERETTA MODEL 1951 PISTOL (ITALY)		
General	13	18
Technical Data	14	18
Operation	15	18
Disassembly and Assembly	16	20
Functioning	17	21
Accessories	18	24

TABLE OF CONTENTS (Continued)

	<i>Para</i>	<i>Page</i>
SECTION I. PISTOLS (Continued)		
D. THE 9-MM M.A.S. MODEL 1950 PISTOL (FRANCE)		
General	19	24
Technical Data	20	25
Operation	21	25
Disassembly and Assembly	22	26
Functioning	23	27
Accessories	24	29
E. THE 9-MM M.A.B. P15 PISTOL (FRANCE)		
General	25	29
Technical Data	26	30
Operation	27	31
Disassembly and Assembly	28	32
Functioning	29	33
Accessories	30	36
F. THE 9-MM HECKLER AND KOCH P9 AND P9S PISTOLS (WEST GERMANY)		
General	31	36
Technical Data	32	37
Operation	33	37
Disassembly and Assembly	34	39
Functioning	35	40
Accessories	36	44

TABLE OF CONTENTS (Continued)

	Para	Page
SECTION I. PISTOLS (Continued)		
G. THE 9-MM MODEL 49 (SIG P210) PISTOL (SWITZERLAND)		
General	37	45
Technical Data	38	46
Operation	39	46
Disassembly and Assembly	40	47
Functioning	41	48
Accessories	42	50
G.1. THE 9-MM MODEL 75 (SIG-SAUER P210) PISTOL (SWITZERLAND)		
General	42.1	52
Technical Data	42.2	53
Operation	42.3	53
Disassembly and Assembly	42.4	54.2
Functioning	42.5	54.5
Accessories	42.6	54.9
H. MISCELLANEOUS PISTOLS		
General	42.1.1	54.10
The Spanish 9-mm Super Star Pistol	42.2.1	54.10
The West German 9-mm VP-70 Pistol	42.3.1	54.11
The Japanese 9-mm Model 57A Pistol	42.4.1	54.13
The Japanese 7.65-mm Model 57B Pistol	42.5.1	54.14

TABLE OF CONTENTS (Continued)

	Para	Page
I. MAINTENANCE		
Care and Cleaning	43	54.15
Malfunctions and Stoppages ..	44	54.15
SECTION II. SUBMACHINEGUNS		
A. THE 9-MM L2A3 and L34A1 SUBMACHINEGUNS (UK)		
General	45	55
Technical Data	46	56
Operation	47	56
Disassembly and Assembly	48	58
Functioning	49	59
Accessories	50	62
B. THE 9-MM UZI SUBMACHINEGUN (ISRAEL)		
General	51	62
Technical Data	52	63
Operation	53	64
Disassembly and Assembly	54	65
Functioning	55	66
Accessories	56	68
C. THE 9-MM M.A.T. MODEL 1949 SUBMACHINEGUN (MAT-49) (FRANCE)		
General	57	69
Technical Data	58	70
Operation	59	70
Disassembly and Assembly	60	72
Functioning	61	73
Accessories	62	74

TABLE OF CONTENTS (Continued)

	Para	Page
D. THE 9-MM MADSEN MODEL 50 SUBMACHINEGUN (DENMARK)		
General	63	74
Technical Data	64	77
Operation	65	77
Disassembly and Assembly	66	78
Functioning	67	79
Accessories	68	80
E. THE 9-MM M45b SUBMACHINEGUN (SWEDEN)		
General	69	80
Technical Data	70	80
Operation	71	82
Disassembly and Assembly	72	83
Functioning	73	84
Accessories	74	85
F. THE 9-MM BERETTA M38, M38/49, M4 AND M5 SUBMACHINEGUNS (ITALY)		
General	75	85
Technical Data	76	87
Operation	77	88
Disassembly and Assembly	78	89
Functioning	79	90
Accessories	80	91

TABLE OF CONTENTS (Continued)

	Para	Page
G. THE 9-MM BERETTA MODEL 12 SUBMACHINEGUN (ITALY)		
General	81	91
Technical Data	82	92
Operation	83	92
Disassembly and Assembly	84	94
Functioning	85	95
Accessories	86	96
H. THE 9-MM STEYR MODEL 69 SUBMACHINEGUN (MPI STEYR 69) (AUSTRIA)		
General	87	97
Technical Data	88	97
Operation	89	97
Disassembly and Assembly ...	90	100
Sight Adjustment	91	102
Functioning	92	104
Accessories	93	107

TABLE OF CONTENTS (Continued)

	Para	Page
SECTION II SUBMACHINEGUNS (Continued)		
I. THE 9-MM WALTHER MP-K AND MP-L SUBMACHINEGUNS (WEST GERMANY)		
General	94	108
Technical Data	95	108
Operation	96	109
Disassembly and Assembly	97	111
Functioning	98	112
Accessories	99	115
J. THE 9-MM H&K MP5 (HK52) SUBMACHINEGUN (WEST GERMANY)		
General	100	115
Technical Data	101	117
Operation	102	117
Disassembly and Assembly	103	117
Functioning	104	117
Accessories	105	117
K. THE 9-MM STEN SUBMACHINEGUN (UK)		
General	106	117
Technical Data	107	119
Operation	108	119

TABLE OF CONTENTS (Continued)

	Para	Page
SECTION II. SUBMACHINEGUNS (Continued)		
K. THE 9-MM STEN SUBMACHINEGUN (UK) (Continued)		
Disassembly and Assembly	109	120
Functioning	110	122
Accessories	111	124
L. MISCELLANEOUS SUBMACHINEGUNS		
General	111.1	124
The Belgium Vigneron Submachinegun	111.2	124
The Portuguese F.B.P. M/48 Submachinegun	111.3	125
★ The South Korean K-1 Submachinegun	111.4	126
M. MAINTENANCE		
Care and Cleaning	112	126
Malfunctions and Stoppages ..	113	126.1
SECTION III. RIFLES		
A. THE 5.56-MM C.A.L. ASSAULT RIFLE (BELGIUM)		
General	114	127
Technical Data	115	127

TABLE OF CONTENTS (Continued)

	Para	Page
SECTION III. RIFLES (Continued)		
A. The 5.56-MM C.A.L. ASSAULT RIFLE (BELGIUM) (Continued)		
Operation	116	127
Disassembly and Assembly	117	130
Functioning	118	133
Accessories	119	136
B. THE 5.56-MM HECKLER AND KOCH HK33 AND HK53 ASSAULT RIFLES (WEST GERMANY)		
General	120	137
Technical Data	121	139
Operation	122	139
Disassembly and Assembly	123	139
Functioning	124	139
Accessories	125	139
C. THE 7.62-MM FN/FAL RIFLE (BELGIUM, UK, ETC.)		
General	126	140
Technical Data	127	144
Operation	128	144
Disassembly and Assembly	129	147
Functioning	130	148
Accessories	131	151

TABLE OF CONTENTS (Continued)

	Para	Page
D. THE 5.56-MM GALIL RIFLE (ISRAEL)		
General	132	152
Technical Data	133	153
Operation	134	153
Disassembly and Assembly	135	158
Functioning	136	159
Accessories	137	163
E. THE 5.56-MM BERETTA M70/.223 RIFLE (ITALY)		
General	138	165
Technical Data	139	167
Operation	140	167
Disassembly and Assembly	141	169
Functioning	142	171
Accessories	143	173
E.1 THE 5.56-MM St.G 77 (AUG) RIFLE (AUSTRIA)		
General	143.1	174
Technical Data	143.2	174.2
Operation	143.3	174.2
Disassembly and Assembly	143.4	174.7
Functioning	143.5	174.12
Accessories	143.6	174.17

TABLE OF CONTENTS (Continued)

	Para	Page
F. THE 7.62-MM G3 RIFLE (WEST GERMANY, ETC.)		
General	144	174.18
Technical Data	145	176
Operation	146	176
Disassembly and Assembly	147	177
Functioning	148	179
Accessories	149	183



TABLE OF CONTENTS (Continued)

	Para	Page
SECTION III. RIFLES (Continued)		
G. THE 7.62-MM BERETTA BM-59 RIFLE (ITALY)		
General	150	183
Technical Data	151	185
Operation	152	185
Disassembly and Assembly	153	186
Functioning	154	188
Accessories	155	190
H. THE 7.5-MM MODEL 49 AND 49/56 RIFLES (MAS 49 AND MAS 49/56) (FRANCE)		
General	156	191
Technical Data	157	193
Operation	158	193
Disassembly and Assembly	159	196
Functioning	160	197
Accessories	161	199
I. THE 7.5-MM StG57 (SIG 510) ASSAULT RIFLE (SWITZERLAND)		
General	162	200
Technical Data	163	202
Operation	164	203
Disassembly and Assembly	165	204

TABLE OF CONTENTS (Continued)

	Para	Page
SECTION III. RIFLES (Continued)		
I. THE 7.5-MM StG57 (SIG 510) ASSAULT RIFLE (SWITZERLAND) (Continued)		
Functioning	166	206
Accessories	167	211
J. THE 7.62-MM TYPE 64 RIFLE (JAPAN)		
General	168	213
Technical Data	169	214
Operation	170	214
Disassembly and Assembly	171	215
Functioning	172	216
Accessories	173	218
K. THE 7.5-MM FR-F1 SNIPER'S RIFLE (FRANCE)		
General	174	218
Technical Data	175	220
Operation	176	220
Disassembly and Assembly	177	222
Functioning	178	225
Accessories	179	226

TABLE OF CONTENTS (Continued)

	Para	Page
L. THE 7.5-MM MODEL 1936 RIFLE (MAS-36) (FRANCE)		
General	180	228
Technical Data	181	229
Operation	182	229
Disassembly and Assembly	183	230
Functioning	184	230
Accessories	185	231
M. THE .303 CALIBER (7.7-MM) LEE ENFIELD RIFLES (UK)		
General	186	231
Technical Data	187	233
Operation	188	234
Disassembly and Assembly	189	236
Functioning	190	237
Accessories	191	238
N. MISCELLANEOUS RIFLES		
General	191.1	238.1
The French 5.56 F.A.M.A.S. Rifle	191.2	238.1
The West German H&K SSG Sniper's Rifle	191.3	238.2
The Austrian Stegr 7.62-MM SSG Sniper's Rifle	191.4	238.2
The Belgium 5.56-MM FNC Assault Rifle	191.5	238.3

TABLE OF CONTENTS (Continued)

	Para	Page
SECTION III. RIFLES (Continued)		
O. MAINTENANCE		
Care and Cleaning	192	240
Malfunctions and Stoppages	193	240
SECTION IV. MACHINEGUNS		
A. THE 7.62-MM M.A.G. 58 (BELGIUM) and L7A1 (UK) MACHINEGUNS		
General	194	241
Technical Data	195	243
Operation	196	244
Disassembly and Assembly	197	246
Functioning	198	247
Accessories	199	251
B. THE 7.62-MM AND .303 (7.7-MM) BREN LIGHT MACHINEGUNS (UK)		
General	200	252
Technical Data	201	256
Operation	202	256
Disassembly and Assembly	203	258
Functioning	204	259
Accessories	205	262

TABLE OF CONTENTS (Continued)

	Para	Page
SECTION IV. MACHINEGUNS		
C. THE 7.5-MM AA-52 MACHINEGUN (FRANCE)		
General	206	262
Technical Data	207	264
Operation	208	265
Disassembly and Assembly	209	267
Functioning	210	269
Accessories	211	272
D. THE 7.5-MM MODEL 24/29 LIGHT MACHINEGUN (FRANCE)		
General	212	273
Technical Data	213	274
Operation	214	274
Disassembly and Assembly	215	276
Functioning	216	278
Accessories	217	281
E. THE 5.56-MM or 7.62-MM HECKLER AND KOCH HK 13, HK 21, AND HK 21A1 MACHINEGUNS (WEST GERMANY)		
General	218	282
Technical Data	219	283
Operation	220	284

TABLE OF CONTENTS (Continued)

	Para	Page
E. THE 5.56-MM or 7.62-MM HECKLER AND KOCH HK 13, HK 21, AND HK 21A1 MACHINEGUNS (WEST GERMANY) (Continued)		
Disassembly and Assembly	221	286
Functioning	222	286
Accessories	223	287
F. THE 7.62-MM MG-1/MG-3 MACHINEGUN (WEST GERMANY)		
General	224	287
Technical Data	225	292
Operation	226	292
Disassembly and Assembly	227	294
Functioning	228	296
Accessories	229	299
G. THE 7.62-MM TYPE 62 AND TYPE 74 MACHINEGUNS (JAPAN)		
General	230	300
Technical Data	231	302
Operation	232	302
Disassembly and Assembly	233	304
Functioning	234	304.2
Accessories	235	307
★ H. THE 5.56-MM MINIMI LIGHT MACHINEGUN (BELGIUM)		
General	235.1	308
Technical Data	235.2	309
Operation	235.3	309

TABLE OF CONTENTS (Continued)

	Para	Page
SECTION IV. MACHINEGUNS		
I. MAINTENANCE		
Care and Cleaning	236	309
Malfunctions and Stoppages ..	237	309
SECTION V. AMMUNITION		
General	238	313
References	239	313
Distribution List		315

3 February 1984

LIST OF ILLUSTRATIONS

<u>Figure</u>		<u>Page</u>
1.	9-mm P1 Pistole	1
2.	P1 Pistole, Disassembled	4
3.	P1 Pistole, Section	6
4.	9-mm FN Browning High Power Pistol ...	8
5.	Indonesian "PINDAD" Pistol	9
6.	Browning High Power Pistol With Long-Range Sights	10
7.	Canadian No. 2 MK 1* Pistol	11
8.	British L9A1 Pistol	12
9.	High Power Pistol, Disassembled	14
10.	Browning High Power Pistol, Section ..	16
11.	Beretta Model 1951 Pistol	18
12.	Beretta Model 1951 Disassembled	20
13.	Beretta Model 1951 Section	22
14.	French Model 1950 Pistol	24
15.	Model 1950 pistol, Disassembled	26
16.	French M.A.B. P15S Pistol	30
17.	French M.A.B. P15-PAP Model F1	31
18.	M.A.B. P15S Disassembled	32
19.	M.A.B. P15 Barrel and Slide	33
20.	M.A.B. P15 Section	34
21.	West German P9 Pistol	36
22.	P9 Disassembled	39
23.	P9 Bolt Functioning	41
24.	P9 Trigger Mechanism Functioning	42
25.	Swiss Model 49 (SIG P210) Pistol	45
26.	M49 Pistol, Disassembled	47
27.	M49 Pistol, Section	49
28.	M49 Pistol .22 Caliber Conversion Unit	51
28.1.	Swiss 9-mm Model 75 Pistol	53
28.1.1.	Swiss 9-mm Model 75 Pistol, Exploded View	54.1
28.1.2.	Model 75 Pistol Disassembled	54.3
28.1.3.	Removal of Driving Spring and Barrel From Model 75 Pistol	54.4

LIST OF ILLUSTRATIONS

<u>Figure</u>	<u>Page</u>
28.1.4. Model 75 trigger mechanism, cocked ..	54.6
28.1.5. Model 75 trigger mechanism, at rest .	54.7
28.1.6. Swiss Model 75 pistol with (from left to right) cleaning kit, spare magazine carrier, and holster	54.9
28.2.1. The Spanish 9-mm Super Star Pistol ..	54.11
28.2.2. The West German 9-mm H&K VP-70 machine pistol	54.12
28.2.3. The VP-70 with holster-stock attached	54.12
28.2.4. The Japanese 9-mm Model 57A pistol ..	54.13
28.2.5. The Japanese 7.65-mm Model 57B pistol	54.13



3 February 1984

<u>Figure</u>	<u>Page</u>
29. British L2A3 Submachinegun	55
30. British L34A1 Silenced Submachinegun	56
31. L2A3 Submachinegun, Section	60
32. Israeli UZI Submachinegun, Early Model	63
33. UZI Submachinegun, Late Model With Folding Butt	64
34. UZI Submachinegun, Field Stripped	66
35. UZI Submachinegun, Section	67
36. French M.A.T. 49 Submachinegun	70
37. M.A.T. 49 Disassembled	73
38. Danish Madsen Model 50 Submachinegun	75
39. Madsen Model 1953 Submachinegun	76
40. Brazilian INA 53 Submachinegun	76
41. Madsen M1946 Submachinegun Section ...	79
42. Swedish M45b Submachinegun	81
43. Egyptian Port Said Submachinegun	81
44. M45b Section	84
45. Italian Beretta M38A Submachinegun ...	86
46. Beretta M38/42 Submachinegun	86
47. Beretta Model 4 and Model 5 Submachineguns	87
48. Beretta Submachinegun, Disassembled ..	89
49. Italian Beretta Model 12 Submachinegun (Early Model)	91
50. Beretta Model 12 Submachinegun, Stock Folded, (Late Model)	94
51. Beretta Model 12 Disassembled	98
52. Austrian Steyr MPi 69 Submachinegun ..	98
53. MPi Steyr 69 Disassembled	101
54. MPi Steyr 69 Section	105
55. West German Walther MP-K Submachinegun	108
56. West German Walther MP-L Submachinegun	109

3 February 1984

<u>Figure</u>	<u>Page</u>
57. Walther MP-K Disassembled	111
58. Walther MP-K or MP-L Section	113
59. West German Heckler and Koch MP5A2 and MP5A3	116
60. British Mark 5 Sten Submachinegun	118
61. Sten Mark 1, 2, 3 and 5 Submachineguns	118
62. Sten Mark 2S Silenced Submachinegun ..	119
63. Sten Mark Submachinegun, Disassembled	121
64. Sten Trigger Mechanism	123
64.1. The Belgium Vigneron Submachinegun ...	125
64.2. The Portuguese F.B.P. M/48 Submachinegun	125
★ 64.3. South Korean K-1 Submachinegun	126
65. Belgium C.A.L. Assault Rifle	128
66. C.A.L. With Folding Metal Butt Stock	129
67. C.A.L. Open for Disassembly	131
68. C.A.L. Bolt	132
69. C.A.L. Burst Limiter	135
70. C.A.L. Bayonet	136
71. C.A.L. Bipod	136
72. West German HK 33 Rifles	138
73. West German HK 33K and HK 53	138
74. Belgium FN/FAL Rifle	140
75. FN/FAL With Metal Forearm and Bipod	140
76. British L1A1 Rifle	141
77. Indian Ishapore Rifle	141
78. FN/FAL Rifle, Early Version	142
79. FN/FAL Paratrooper's Model	143

LIST OF ILLUSTRATIONS

<u>Figure</u>	<u>Page</u>
80. Canadian C2A1 automatic rifle	143
81. FN/FAL (FALO) automatic rifle	143
82. Israeli FN/FAL rifle and automatic rifle	144
83. L1A1 receiver details	145
84. FN/FAL bolt mechanism	149
85. FN/FAL trigger	150
86. Israeli Galil rifle	153
87. Galil on bipod	154
88. Galil with folded stock	154
89. Loading the Galil	155
90. Loading a rifle grenade	157
91. Removing gas cylinder tube	158
92. Galil mechanism	161
93. Using the Galil to cut wire	163
94. Galil bayonet	164
95. Galil bottle opener	164
96. Galil front night sight	165
97. Italian Beretta M70/.223 rifle	166
98. Beretta M70/.223 rifle with folding stock (early model)	166
99. Beretta M70/.223 automatic rifle	167
100. Beretta M70/.223 disassembled	169
101. Beretta M70/.223 section	172
102. Beretta M70/.223 bayonet	173
103. Beretta M70/.223 telescopic sight ...	174
103.1. Austrian 5.56-mm St.G. 77 (AUG) assault rifle with 508-mm barrel ..	174.1
103.2. Austrian St.G. 77 (AUG) with 610-mm barrel. Operating handle locked to rear	174.2
103.3. St.G. 77 (AUG) controls	174.3
103.4. Barrel removal	174.5
103.5. Barrel removed	174.6
103.6. Separation of receiver from stock ...	174.7

LIST OF ILLUSTRATIONS

<u>Figure</u>		<u>Page</u>
103.7.	Removal of bolt mechanism from receiver	174.8
103.8.	Bolt unit disassembled	174.9
103.9.	Releasing rear sling swivel	174.10
103.10.	Stock unit disassembled	174.11
103.11.	St.G. 77 (AUG) field stripped	174.12
103.12.	Bolt functioning	174.13
103.13.	Hammer housing functioning	174.16
104.	Early G3 (CETME) rifle	174.18
105.	West German G3 rifle	175
106.	G3 disassembled	178
107.	G3 bolt functioning	179
108.	G3 rifle section	181
109.	Italian BM 59 Mark 1 rifle	183
110.	BM 59 Mark Ital rifle	184
111.	BM 59 Mark Ital-A paratrooper's rifle	184
112.	BM 59 mechanism	189
113.	French M.A.S. 49 rifle	191
114.	M.A.S. 49 grenade launcher	192
115.	M.A.S. 49/56 rifle	192
116.	M.A.S. 49/56 with rifle grenade	194
117.	M.A.S. 49/56 grenade launcher and sight	195
118.	M.A.S. 49 disassembled	196
119.	M.A.S. 49/56 section	197
120.	M.A.S. 49/56 bolt	198
121.	M.A.S. 49/56 bayonet	200
122.	Swiss St.G. 57 assault rifle	201
123.	St.G. 57 with bipod extended	201
124.	Swiss SIG 510-4 assault rifle	202
125.	Early SIG 510 assault rifle	202
126.	St.G. 57 disassembly	205
127.	St.G. 57 bolt functioning	206
128.	St.G. 57 bolt	207
129.	SIG 510-4 section	208
130.	St.G. 57 trigger mechanism	209

<u>Figure</u>	<u>Page</u>
131. St.G. 57 Trigger Functioning	210
132. Japanese Type 64 Rifle	213
133. French FR-F1 Sniper's Rifle	218
134. FR-F1, Left Side View	219
135. APX 804 Telescopic Sight	219
136. Sight Picture	222
137. FR-F1 Bolt Removal	223
138. French M.A.S. 36 Rifle	228
139. French M.A.S. 36 CR 39 Rifle	229
140. Lee Enfield Rifles	233
140.1. The French F.A.M.A.S. Rifle	238.1
140.2. The West German H&K SSG Sniper's Rifle	238.2
140.3. The Austrian 7.62-mm Steyr SSG Sniper's Rifle	238.3
140.4. The Belgium 5.56-mm FNC Assault Rifle, Stock Extended	238.4
140.5. The Belgium FNC Assault Rifle, Stock Folded	238.4
141. Belgium M.A.G. Machinegun	241
142. British L7A1 Machinegun	242
143. M.A.G. on Tripod Mount	242
144. L7A1 on Tripod Mount (w/o Butt Stock)	243
145. Tank Versions of the M.A.G./L7A1	243
146. M.A.G. Disassembled	246
147. M.A.G. Bolt Functioning	248
148. M.A.G. Trigger Functioning	249
149. M.A.G. Feed Mechanism Functioning ...	250
150. Mark 1 Bren	253
151. Mark 2 Bren	253
152. Mark 2M Bren	254
153. L4A1 Bren	254
154. L4A1 Bren	255
155. Nationalist Chinese Type 41 Bren	255

3 February 1984

<u>Figure</u>	<u>Page</u>
156. Bren Bolt and Trigger Mechanism Functioning	260
157. French AA-52 Light Machinegun	263
158. French AA-52 Heavy Machinegun	263
159. AA-52 Heavy Machinegun on Tripod	264
160. AAT-52 Tank Machinegun	265
161. AA-52 Barrel Change	267
162. AA-52 Disassembled	268
163. AA-52 Section	270
164. AA-52 Bolt and Feed Cover	272
165. French Model 24/29 Light Machinegun ..	274
166. M24/29 Disassembled	277
167. M24/29 Section	279
168. M24/29 Trigger Mechanism	280
169. West German HK 13 Light Machinegun ...	282
170. West German HK 21 Machinegun	283
170.1. West German HK 21A1 Machinegun	283
171. West German HK 21A1 Feeder	285
171.1. Inserting Feed Belt With Feed Tab; Feeder Closed	286
172. HK 21 Barrel Change	287
173. H21 Section	288
174. HK 21A1 Feeder Mechanism	290
175. Old German MG 42 Machinegun	290
176. West German MG1 or MG3 Machinegun	291
177. MG 42, MG1, MG3 Barrel Change	293
178. MG-1 Disassembled	295
179. MG-1 Bolt	296
180. MG-1 Bolt Functioning	297
181. MG-1 Trigger Functioning	298
182. Japanese Type 62 Machinegun	300
182.1. Japanese Type 74 Machinegun	301
183. Type 62 With Telescopic Sight Attached	301
183.1. Current Production Type 62	302
184. Type 62 Disassembled	304.1
185. Type 62 Section	306
★ 185.1. Belgian Minimi Light Machinegun	308
186. Ammunition Identification Guide	314

LIST OF TABLES

Table	Page
I. Pistol Technical Data	54.15
II. Pistol Malfunctions	54.16
III. Submachinegun Technical Data	125
IV. Submachinegun Malfunctions	126
V. Rifle Technical Data	239
VI. Rifle Malfunctions	240
VII. Machinegun Technical Data	309
VIII. Machinegun Malfunctions	310

(Reverse Blank)



SMALL ARMS IDENTIFICATION AND OPERATION GUIDE—FREE WORLD

SECTION I. PISTOLS

A. THE 9-MM PISTOLE P1 (WEST GERMANY)

1. General

a. The 9-mm Pistole P1 (fig 1) is the standard side arm of the West German Army. Commercial versions are used by other armies. The P1, descended from the World War II vintage German P-38, differs from the older pistol in its lightweight dural receiver and redesigned firing pin. The latter is not interchangeable with the older P-38 firing pin. The P1 and its civilian version, the P-38, both bear identical manufacturers' markings on the slide: the word "Walther" enclosed in a banner followed by the legend "Carl Walther Waffenfabrik Ulm/Do." Below this a second line reads "P1 Cal 9-mm" for West German Army weapons, or "P-38 Cal 9-mm" for commercial weapons. World War II vintage P-38's carry a code symbol such as "ac", "byf", "cyq", or "sw" with a two-digit date on the slide.

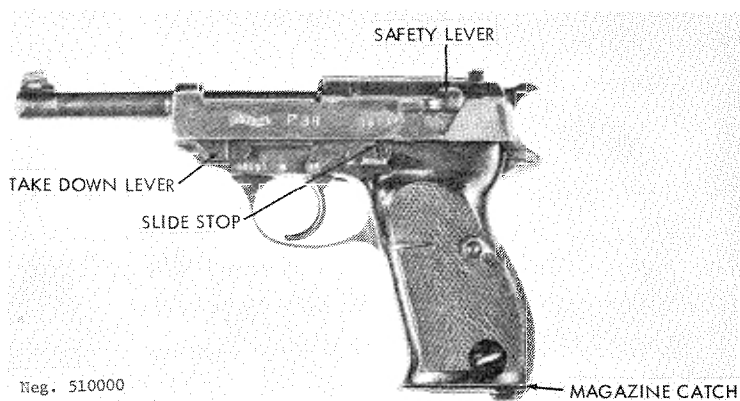

Figure 1. 9-mm P1 pistol.

b. The P1 is an eight-shot, semiautomatic, recoil-operated weapon fed from a detachable box magazine. This pistol has a double-action trigger mechanism that, in addition to conventional functioning, allows the hammer to be cocked and released by a single long pull on the trigger. The P1 fires the 9x19-mm pistol cartridge (sec V).

2. Technical Data

Technical data concerning the Pistole P1 are given in table I.

3. Operation

a. Remove the magazine by pressing the magazine catch (fig 1) rearward, away from the magazine, and withdrawing the magazine. If open, the slide can be closed either by pulling it slightly rearward and releasing it, or by pressing the slide stop (fig 1) downward.

b. Load the magazine by placing a cartridge on the magazine follower just forward of the feed lips; press the cartridge down and slide it to the rear, under the feed lips, until it seats against the rear wall of the magazine. Repeat this action until the magazine is full.

c. Insert the magazine into the pistol until the magazine catch (fig 1) snaps into place.

d. Grasp the slide by its serrations and pull it fully rearward. Release the slide, and it will run forward and load the first cartridge. CAUTION: The pistol is now ready to fire. A small pin (fig 3) protrudes from the slide, above the hammer, to indicate that the pistol has a cartridge in its chamber.

e. If desired, set the pistol on safe by rotating the safety lever (fig 1) downward as far as possible. If the hammer is cocked, it will snap forward, but the pistol will not fire.

f. To fire the weapon, rotate the safety upward until its lever is horizontal. The hammer can be manually cocked by pressing it rearward by thumb pressure or, when the pistol is aimed, the trigger can be pressed through its full travel. (The first method is preferred because of the greater accuracy of fire.) Using a conventional sight picture, aim and press the trigger for each shot. The slide will remain open when the last round is fired. Remove the magazine (a above).

g. To clear the pistol, set it on safe (e above), remove the magazine, and retract the slide. Press the slide stop upward and release the slide; it will be held open. Inspect to insure that no cartridges are present. Press down the slide stop and insert the magazine.

4. Disassembly and Assembly

To disassemble the P1 for cleaning, and to reassemble it, the following steps must be taken:

a. Clear the weapon (para 3g), but do not insert the magazine. Leave the safety lever set on safe. Retract the slide, and lock it to the rear with the slide stop (para 3g). Rotate the takedown lever (fig 1) downward. Pull the slide slightly rearward (to release the slide stop); then ease it forward. The hammer will fall as the slide aligns with the receiver; continue to move the slide forward until both it and the barrel are free of the receiver.

b. Invert the slide and barrel. Press in on the unlocking plunger (fig 2) to unlock the barrel from the slide and push the barrel forward, out of the slide.

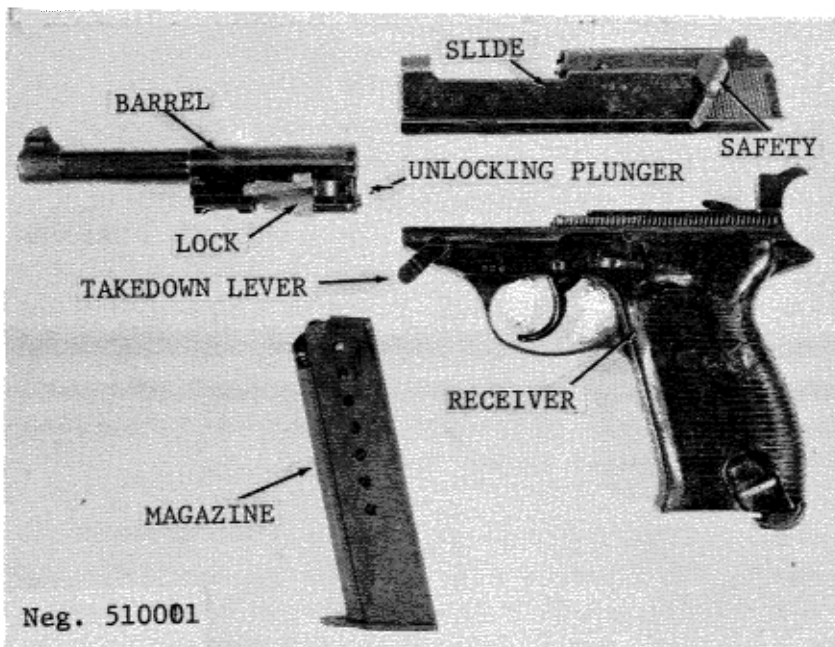

Figure 2. P1 pistol, disassembled.

c. No further disassembly is necessary nor desirable.

d. To reassemble the pistol, insert the barrel into the inverted slide; when the barrel is seated against the slide face, press the lock (fig 2) down.

e. Be sure that the hammer is uncocked, that the ejector is pushed forward into the magazine well, and that the takedown lever is rotated fully forward.

f. Turn the slide so that the sights are up and join the slide to the receiver. Pull the slide fully rearward and hold it there with the slide stop. Rotate the takedown lever back to its normal position. Release the slide and insert the magazine.

5. Functioning

a. The P1 pistol is recoil operated. The barrel and slide are locked together at the instant of firing; the rearward movement of the barrel (as the result of recoil) unlocks the slide from the barrel and imparts to the slide sufficient inertia to drive it fully rearward against the driving springs. These springs provide the thrust to drive the slide forward and to reload the barrel with another cartridge.

b. If the hammer is in its forward position, finger pressure on the trigger moves the trigger bar (fig 3-14) forward. A hook on the upper rear end of the trigger bar engages the sear (fig 3-15), and as the trigger bar continues forward, the sear rotates upward. The pawl (fig 3-12) on the hammer is lifted by the sear and causes the hammer to rock back. The sear eventually moves far enough forward to release the pawl; when this happens, the hammer, under the force of its spring (fig 3-8), swings forward and strikes the firing pin to fire the pistol. As the slide recoils, it depresses the trigger bar, which then disengages from the sear. The sear spring immediately returns the sear to its original position.

c. As the slide recoils, it rocks the hammer back. A projection on the bottom of the hammer contacts the sear and lifts it up. When the slide counterrecoils and releases the hammer, the projection on the bottom of the hammer is caught by a notch in the bottom of the spring loaded sear (fig 3-15), and the hammer is held cocked.

d. Pressure on the trigger moves the trigger bar (fig 3-14) forward, and a hook on the end of the trigger bar pulls the sear out of engagement with the hammer. The hammer swings forward and strikes the firing pin (fig 3), to fire the cartridge. The recoiling slide depresses the trigger bar out of engagement with the sear, and the action described in paragraph c above starts again.

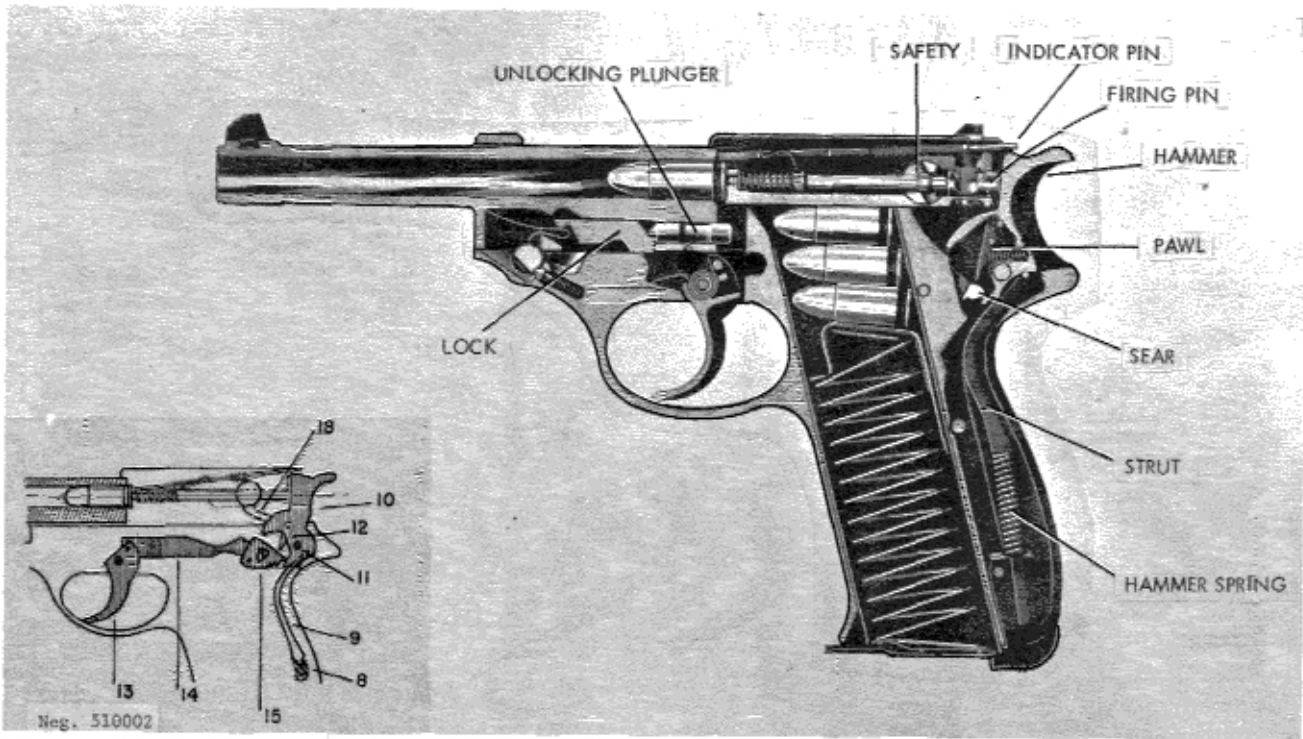

Figure 3. P1 pistol, section.

e. The barrel is locked to the slide by the lock (fig 3), and together they recoil on the receiver when the pistol fires. As the lock moves rearward, off a shelf in the receiver, the unlocking plunger (fig 3) hits the receiver and stops. The lock moves rearward onto the now stationary unlocking plunger and is cammed down out of engagement with the slide.

f. Because of its inertia, the slide continues rearward and compresses the dual driving springs. The extractor pulls the fired cartridge from the barrel and holds it to the slide until the case strikes the ejector and is expelled. The driving springs force the slide forward and a new cartridge is loaded into the chamber.

g. The barrel is held rearward by the lock, which in turn is held down by ribs inside the slide. When the locking recesses in the slide align with the lock, the barrel is driven forward by the slide and a cam surface lifts the lock, which locks the barrel and slide together.

h. When the safety lever is rotated to the safe position, a cam surface depresses the trip (fig 3-18). The trip forces the sear out of contact with the hammer, and the hammer falls. As it rotates, the safety also interposes a solid block in the path of the firing pin. This prevents the pistol from firing.

i. A ledge on the magazine follower pushes the slide stop upward when the last round is fed from the magazine. The stop then automatically holds the slide open.

6. Accessories

A leather holster with a pocket for an extra magazine, a cleaning rod, and a lanyard are usually issued in conjunction with the P1 pistol. Conversion kits to allow the use of 4-mm subcaliber cartridges or to convert the pistol to .22 caliber rimfire cartridges are available for use in training.

B. THE 9-MM F.N. BROWNING HIGH POWER PISTOL (BELGIUM)

7. General

a. The F.N. Browning High Power pistol (fig 4) was introduced in 1935 and since then has become one of the world's most widely used pistols. This pistol, currently produced in Belgium, has been manufactured in Canada and in Indonesia. The Belgium products bear the legend "FABRIQUE NATIONALE D'ARMES DE GUERRE HERSTAL-BELGIGUE" and "Browning Patent Depose" on the left side of the slide. The addition of a stamped P35 (b) indicates a pistol used by the Germans during World War II. The Indonesian pistols (fig 5) bear the stamping "FABRIK SENDJATA RINGAN" over "PINDAD" followed by "PiA 9-mm". The Canadian-produced pistols were made for Canada, UK, and Nationalist China. These pistols are stamped on the left of the slide, "BROWNING FN HP INGLES CANADA", and have a model designation: No. 1, Mk 1; No. 1, Mk 1*; No 2, Mk 1; or No. 2. Mk 1*.



Figure 4. 9-mm FN Browning High Power pistol.



Figure 5. Indonesian "PINDAD" pistol.

b. In addition to the different manufacturers, there are several distinct versions of the Browning High Power pistol:

(1) A basic model (fig 4) with sights similar to those on the US M1911 A1 pistol. This is the most common version; the Indonesian pistol follows this pattern.

(2) A model equipped with an adjustable tangent-ramp long-range rear sight (fig 6). This sight is graduated up to 500 yards. Pistols with this sight usually have a slot attaching a buttstock milled into the frame (fig 6). The Canadian No. 1 Mk1 and No. 1 Mk1* pistols conform to this model.



Figure 6. Browning High Power pistol with long-range sights.

(3) The Canadian model, similar to the basic model (1) above, but with a prominent hump on the slide for the rear sight (fig 7). The No. 2 Mk 1 and No. 2 Mk 1* pistols conform to this pattern. The No. 2 Mk 1* is the only model now in use by the UK forces.

(4) The current production Browning has its extractor exposed behind the ejection port and has a multipiece barrel. (The tube is brazed into a sleeve containing bullet ramp and cam.) The current standard UK L9A1 pistol (fig 8) is of this type. The L9A1 can be distinguished from the commercial pistols by the additional



Figure 7. Canadian No. 2 Mk 1* pistol.

stamping on the left side of the slide “PISTOL - AUTOMATIC 9-mm L9A1”. Commercial pistols sold to governments in quantity are often found with national crests stamped into the slide. Each Browning High Power usually carries its serial number in three places—on the barrel, visible in the ejection port; in the slide, directly below the ejection port; and on the receiver, directly below the slide number (fig 7). These numbers should agree. If they differ, the pistol has been assembled from parts of different pistols.

c. All Browning High Power pistols are recoil-operated, semiautomatic weapons feeding from a 13-round capacity box magazine. A safety device that prevents firing unless a magazine is in place is found in all but the World War II German models. All Browning High Power pistols fire the 9x19-mm cartridge (sec V).

Original



Figure 8. British L9A1 pistol.

8. Technical Data

Technical data concerning the Browning High Power are given in table I.

9. Operation

a. Remove the magazine by pressing the magazine catch (fig 4). The magazine normally will eject, but if necessary, pull it out of the pistol. Load the magazine as described in paragraph 3b. It will hold 13 cartridges.

b. Insert the loaded magazine into the pistol until the magazine catch snaps into place. Tap the base of the magazine with the palm to insure it is seated and locked in place.

c. Grasp the slide by its serrations, and pull it fully rearward. Release the slide; it will run forward and load the first cartridge. CAUTION: The pistol is now ready to fire.

d. If desired, set the pistol on safe by pressing the safety (fig 4) fully upward; alternatively, the hammer can be lowered to the half cock/safe position. Do this by carefully thumbing the hammer rearward and, after pressing the trigger, easing the hammer slightly forward. Release the trigger and allow the hammer to come to rest at half cock.

e. To fire, press the safety downward or bring the hammer back to full cock. Aim (using a conventional sight picture), and press the trigger for each shot. The slide will remain open when the last round is fired.

f. Remove the magazine by pressing the magazine catch (fig 4). The magazine normally will eject, but, if necessary, pull it out of the pistol. The slide, if open, can be closed by pulling it slightly rearward, or the slide stop (fig 4) can be pressed downward.

g. To clear the pistol, remove the magazine and retract the slide. Press the rear of the slide stop up, and ease the slide forward; it will be held open. Inspect the pistol to insure that no cartridges are present. Press the slide stop down to release the slide, insert the magazine, and press the trigger. Note: Most Browning High Power pistols have a magazine safety to prevent the hammer from falling unless the magazine is inserted.

10. Disassembly and Assembly

a. To disassemble the Browning High Power for cleaning:

(1) Clear the weapon (para 9g), but do not insert the magazine.

(2) Retract the slide until the safety can be pressed up into the dismounting notch (fig 9). Press the rear of the slide stop up, and then press in on the right end of the slide stop pin to start the slide stop out of the receiver. Pull the slide stop fully out.

(3) Hold the slide, and press the safety down. Ease the slide forward, and pull it from the receiver.

(4) Grasp the driving spring guide (fig 9) and pull it forward (out of its seat in the barrel); then ease the guide and spring up and out of the slide.

(5) Pull the rear end of the barrel out of the slide; then pull the barrel rearward until it is free.

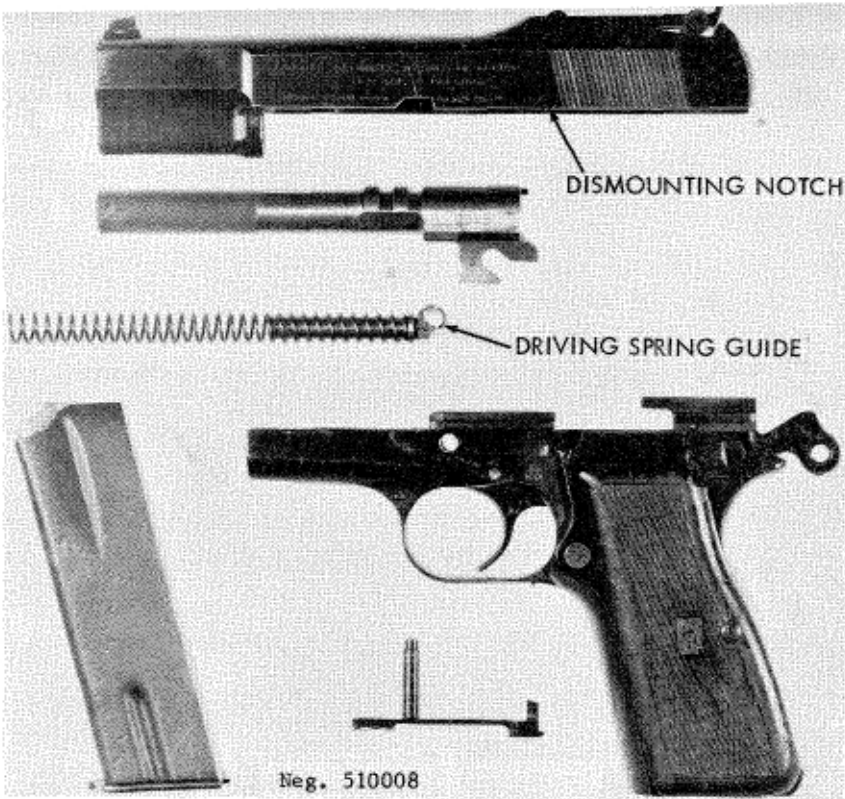

Figure 9. High Power pistol, disassembled.

(6) No further disassembly is necessary or desirable.

b. To reassemble the Browning High Power:

(1) Insert the muzzle end of the barrel into the slide; press the rear end of the barrel into the slide and move the barrel rearward until its locking ribs snap into place in the slide. Insert the free end of the driving spring into its tunnel in the front of the slide; then mate the driving spring guide to the barrel. Note: The hole in the guide must be positioned so that it is toward the barrel; refer to figure 9 for correct positioning.

(2) Start the slide onto the rails of the receiver (from the front) and pull the slide rearward until the safety can be pressed into the dismounting notch. Insert the slide stop pin (from left to right) into its hole and fully seat it. Disengage the safety from the slide and insert the magazine. Pull the trigger.

11. Functioning

a. The Browning High Power is recoil operated. (Refer to para 5a.)

b. When the hammer is cocked and the trigger is pressed, the trigger pivots on its pin. The tripping lever (fig 10-15) rises and contacts the connector (fig 10). The connector then rotates on its pin, and its rear end causes the sear (fig 10-8) to turn and release the hammer. The hammer swings forward, strikes the firing pin, and a shot is fired.

c. The barrel and slide, locked together, recoil as a unit to compress the driving spring and rock the hammer back. The cam cut in the lug on the barrel mates with a cross pin in the receiver; this pulls the barrel ribs down, out of engagement with the slide. The inertia of the slide continues moving it to the rear and compresses the driving spring.

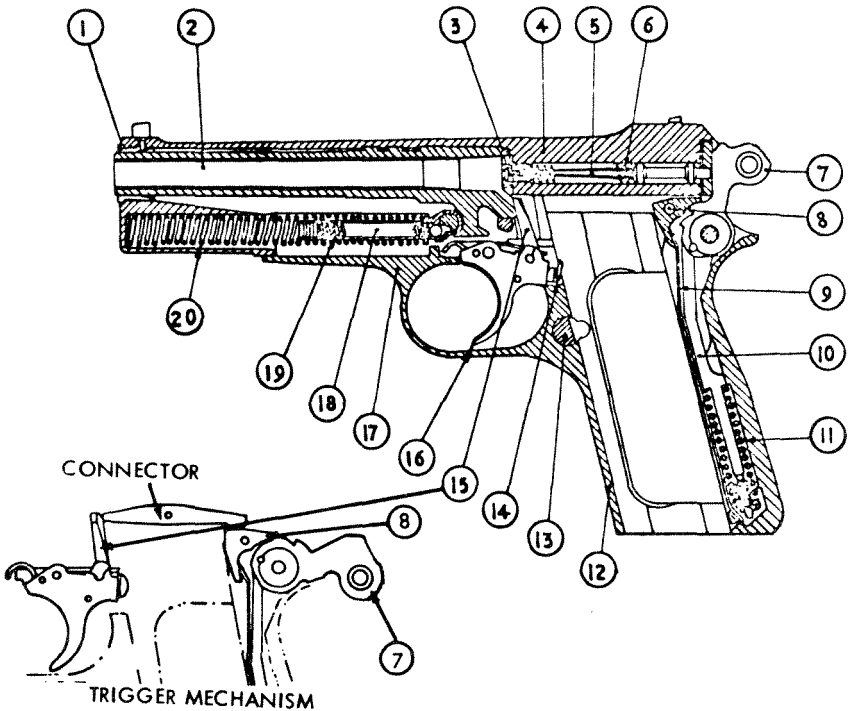

- | | |
|----------------------------------------------------------|------------------------------|
| 1. Bush, slide, front | 11. Spring, link |
| 2. Barrel | 12. Butt |
| 3. Bush, slide, rear (alternative method of manufacture) | 13. Catch, magazine |
| 4. Slide | 14. Plunger, lever, tripping |
| 5. Pins, firing | 15. Lever, tripping |
| 6. Spring, pin, firing | 16. Trigger |
| 7. Hammer | 17. Body |
| 8. Sear | 18. Guide, spring, main |
| 9. Spring, sear | 19. Spring, lever, locking |
| 10. Link, hammer | 20. Spring, main |

Neg. 510009

Figure 10. Browning High Power pistol, section.

d. The extractor pulls the fired cartridge case from the chamber and holds it to the slide. The case strikes the fixed ejector and is expelled. The driving spring then forces the slide forward. As the slide moves forward, the feed rib drives a cartridge out of

the magazine and into the barrel. The slide strikes the rear end of the barrel; the barrel is forced forward; and the cross pin cams the rear of the barrel up into the locked position.

e. At the start of slide recoil, the connector, which is attached to the slide, moves rearward, off the tripping lever and sear. The sear, under pressure of its spring, snaps against the hammer and holds the hammer cocked when the slide counterrecoils.

f. During the final counterrecoil travel of the slide, the connector strikes the lifted tripping lever and swings it forward. As the trigger is released, the tripping lever moves downward and, as it clears the connector, it moves rearward under the connector. Pressure on the trigger will now fire another shot.

g. A lug on the safety, when on safe, blocks movement of the sear. This prevents the pistol from firing. The magazine safety (fig 10-14) is a spring-loaded plunger in the trigger. When the magazine is removed, this plunger moves slightly rearward; the plunger contacts the tripping lever and causes it to rotate forward from under the connector. This breaks the linkage between the trigger and sear, and the pistol cannot be fired. Inserting the magazine forces the plunger in and rotates the tripping lever back to its operating position.

h. The magazine follower contacts the slide stop when the last cartridge is fed from the magazine. The pressure of the magazine spring (working through the follower) forces the slide stop up where it can engage and hold open the slide.

12. Accessories

A holster, a spare magazine, a cleaning rod, and a lanyard are used in conjunction with the Browning M35 pistol. These accessories vary widely in design and material.

C. THE 9-MM BERETTA MODEL 1951 PISTOL (ITALY)

13. General

The Italian Beretta 9-mm Model 1951 pistol is the standard side arm of the Italian armed forces and has been sold to several other nations. It is a lightweight, recoil-operated, semiautomatic weapon of conventional design (fig 11). The Beretta M1951 fires 9x19-mm ammunition (sec V).

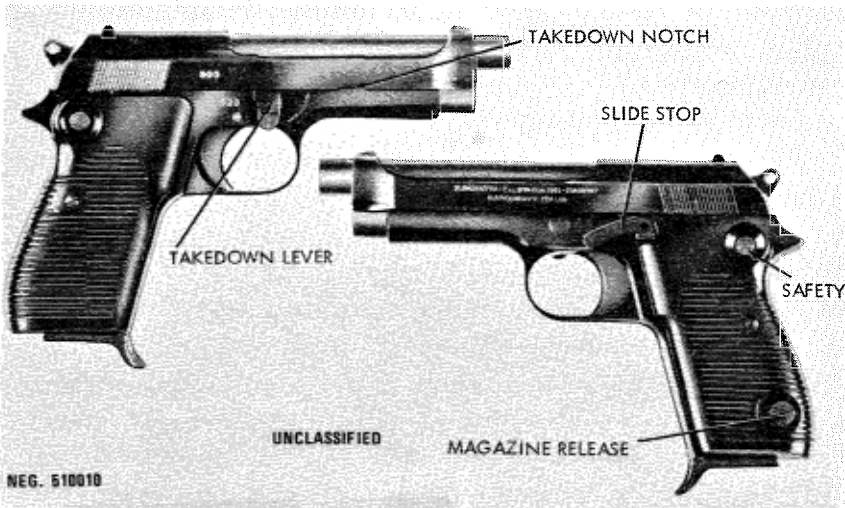

Figure 11. Beretta Model 1951 pistol.

14. Technical Data

Technical data concerning the Beretta Model 1951 pistol will be found in table I.

15. Operation

a. Remove the magazine by pressing the magazine release (fig 11) in the lower left grip and remove the magazine. Load the

magazine with eight cartridges as described in paragraph 3b. Insert the loaded magazine into the pistol until the magazine catch snaps into place and retains the magazine.

b. Grasp the slide by the serrations and pull it fully rearward against the force of the driving spring. Release the slide and allow it to snap forward. CAUTION: The pistol is now ready to fire.

c. To render the pistol safe, press the safety, located in the top rear of the grip (fig 11), from right to left. As an alternative, the hammer can be pulled back by the thumb, the trigger pressed, and the hammer eased forward. CAUTION: Point pistol in a safe direction when doing the latter. The pistol is safe when the hammer is down, because the inertia-type firing pin does not touch the primer. The firing pin requires a sharp blow to impart sufficient inertia to it to fire the primer.

d. To fire, either cock the hammer manually or press the safety (fig 11) to the right. Aim—using a conventional sight picture—and press the trigger. The pistol will fire one shot and reload itself. To fire another shot, release and repress the trigger. When the last round in the magazine is fired, the slide will remain back.

e. Remove the magazine by pressing in the magazine release and withdrawing the magazine. The slide can be closed by either manually depressing the slide stop (fig 11) or by pulling the slide slightly rearward and releasing it. Hold the hammer, press the trigger, and ease the hammer home.

f. Clear the Beretta M1951 by removing the magazine (e above), applying upward pressure on the slide stop and pulling the slide rearward. Ease the slide forward until it is caught by the slide stop. Inspect to insure that no cartridges are present in the

barrel or slide. Pull the slide rearward, then ease it forward. Hold the hammer and press the trigger. Ease the hammer forward. Reinsert the magazine.

16. Disassembly and Assembly

a. Clear the pistol (para 16f), but do not insert the magazine or lower the hammer. Hold the pistol in the left hand and with the right hand, push the slide rearward until the takedown lever (fig 11) aligns with the takedown notch in the slide (fig 11). Hold the slide in place with the left index finger (fig 12). Rotate the takedown lever forward. Ease the slide forward, then pull it forward off the receiver.

b. Press the driving spring guide (fig 12) forward to disengage it, then ease it up and rearward and remove it. With the slide inverted, press forward on the unlocking plunger until the barrel just starts to move forward. Lift the rear end of the barrel out of the slide, then pull the barrel rearward out of the slide. Further disassembly is neither required nor desirable.



Figure 12. Beretta Model 1951 disassembled.

c. To reassemble the pistol, first insert the barrel into the slide, inserting the muzzle through the hole in the front of the slide. With the slide inverted, push the barrel slowly forward until it drops into the slide; press down on the barrel lock (fig 12) and move the barrel slightly rearward. Insert the driving spring into its housing in the front of the slide. Press the driving spring guide (fig 12) forward, slightly compressing the driving spring, until the large ring on the guide can be seated in its recess on the lock (fig 13).

d. Mate the slide with the grooves in the receiver and push the slide onto the receiver as far as possible. Pull the slide rearward, against spring pressure, until the takedown lever can be rotated downward. Release the slide. Hold the hammer, press the trigger, and ease the hammer forward. Insert the magazine.

17. Functioning

a. The Beretta M1951 is recoil-operated (refer to paragraph 5a).

b. When the hammer is cocked and the trigger is pressed, the trigger bar moves rearward and contacts the sear (fig 13). Continued movement of the trigger bar causes the sear to rotate on its pin and the upper end of the sear disengages from the hammer (fig 13). The hammer spring then drives the hammer against the firing pin, firing the cartridge.

c. Upon firing, the barrel and slide, locked together, recoil rearward. After moving a short distance, the unlocking plunger on the barrel (fig 13) strikes a shoulder of the receiver and stops. The barrel and lock continue rearward, and the now stationary unlocking plunger forces the lock down, releasing the barrel from the slide. The slide, because of its inertia, continues rearward, rocking the hammer rearward and compressing the driving spring.

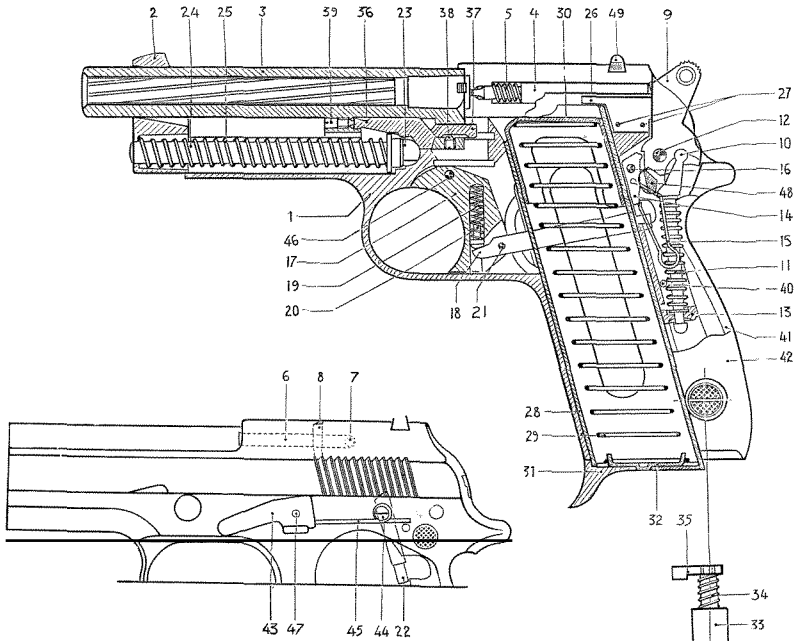

- | | | | |
|--------------------------------|-----------------------------------------|--------------------------------------|------------------------------------|
| 1 - Body | 14 - Sear Lever | 27 - Ejector Pin | 40 - Cheek Screws |
| 2 - Bolt | 15 - Sear Lever and Safety Catch Spring | 28 - Magazine Chamber | 41 - Right Cheek |
| 3 - Barrel | 16 - Sear Lever Pivot | 29 - Magazine Spring (Feeder Spring) | 42 - Left Cheek |
| 4 - Percussion Pin | 17 - Trigger | 30 - Magazine Feeder | 43 - Bolt Catch Lever |
| 5 - Percussion Pin Spring | 18 - Trigger Lever | 31 - Magazine Base | 44 - Bolt Catch Lever Spring Screw |
| 6 - Extractor | 19 - Trigger Lever Spring | 32 - Base Plate | 45 - Bolt Catch Lever Spring |
| 7 - Extractor Spring | 20 - Trigger Lever Spring Rod | 33 - Magazine Catch Button | 46 - Trigger Pivot |
| 8 - Extractor Pin | 21 - Trigger Lever Pivot | 34 - Magazine Catch Spring | 47 - Bolt Catch Lever Pin |
| 9 - Hammer | 22 - Trigger Lever Disengaging Rod | 35 - Magazine Catch | 48 - Safety Catch |
| 10 - Hammer Spring Rod | 23 - Disassembling Catch | 36 - Locking Catch | 49 - Rear Sight |
| 11 - Hammer Spring | 24 - Recoil Spring Rod | 37 - Locking Catch Control Pin | 50 - Locking Catch Spring |
| 12 - Hammer Pivot | 25 - Recoil Spring | 38 - Control Pin Screw | |
| 13 - Hammer Spring Rod Support | 26 - Ejector | 39 - Catch Screw | |

№ 510012

Figure 13. Beretta Model 1951 section.

d. As the slide recoils, the disconnector (fig 13) is forced down by a cam cut into the slide. The disconnector, whose bottom end rests on the trigger bar, forces the trigger bar down, out of engagement with the sear. The sear, powered by its spring, snaps back against the hammer (fig 13).

e. The slide, continuing rearward, pulls the fired cartridge case from the chamber by means of the extractor. The extractor holds the case against the slide until the fixed ejector (fig 13)

strikes the case, pivots it about the extractor, and expels it from the pistol. The driving spring housing strikes the barrel lug and rearward movement ceases.

f. The driving spring (fig 13) now expands and drives the slide forward. The feed rib on the slide drives a cartridge from the magazine into the barrel. As the slide nears its most forward position, it strikes the barrel and drives it forward. The lock rides up a cam in the receiver (fig 13) and locks the barrel to the slide. Forward motion stops when the barrel strikes the takedown lever shaft (fig 13).

g. As the slide moves forward, it allows the hammer to swing forward until the sear engages. The hammer is then held cocked. The spring-loaded trigger bar forces the disconnecter upward and as the slide goes into battery, the disconnecter enters its cam cut in the slide.

h. To fire another shot, the trigger must be released; as it is, the trigger bar moves forward until it clears the sear. As the trigger bar clears the sear, the trigger bar springs up in front of the lower end of the sear. Trigger pressure, when reapplied, will fire another shot.

i. The sliding safety (fig 13) blocks the sear when pressed to the safe position. When the safety is pressed to the fire position, cutaway sections on the safety allow the sear to move and release the hammer.

j. The slide stop is actuated by the follower. When the last round is removed from the magazine, the follower moves almost to its uppermost position. A ledge on the follower contacts the slide stop and transfers the force of the magazine feed spring to the slide stop. When the slide recoils, the slide stop enters a notch on the slide and holds it open.

18. Accessories

A holster of conventional design, spare magazines, and cleaning rods are available as accessories.

D. THE 9-MM M.A.S. MODEL 1950 PISTOL (FRANCE)

19. General

The French Model 1950 (fig 14) pistol is used almost exclusively by the French Army and the armies of former French colonies. It can be readily identified by its general resemblance to the US M1911 A1 pistol and the marking "M.A.S. 1950 cal 9-mm" on the right side of the slide and "M.A.C." or, less commonly, "M.A.S." on the left side of the slide. The prominent safety housing (fig 14) is also a prime recognition feature. The Model 1950 pistol has an automatic safety device that prevents the pistol from being fired unless the magazine is in place. The Model 1950 pistol fires 9x19-mm cartridges (sec V).



Figure 14. French Model 1950 pistol.

20. Technical Data

Technical data concerning the Model 1950 pistol will be found in table I.

21. Operation

a. Remove the magazine by pressing the magazine catch (fig 14). Load the magazine with nine cartridges as described in paragraph 3b. Insert the loaded magazine into the pistol until the magazine catch snaps into place and retains the magazine.

b. Grasp the slide by the serrations and pull it fully rearward. Release the slide and allow it to snap forward. CAUTION: The pistol is now ready to fire. An indicator to the rear of the ejection port projects above the slide to indicate a loaded chamber.

c. To render the pistol safe, rotate the safety (fig 14) upward (to a horizontal position). If desired, the hammer can be lowered by pressing the trigger. The Model 1950 will not fire because the safety blocks the hammer from striking the firing pin.

d. To fire, rotate the safety downward (a red dot is exposed), cock the hammer if necessary, aim (using a normal sight picture), and squeeze the trigger. The Model 1950 will fire one shot each time the trigger is pressed and released. The slide will remain open when the last round has been fired.

e. Remove the magazine by pressing the magazine catch (fig 14), or by pulling the slide slightly rearward and releasing. The magazine must be reinserted before pressing the trigger to lower the hammer.

f. Clear the Model 1950 by applying the safety (c above), removing the magazine (e above), applying upward pressure on the

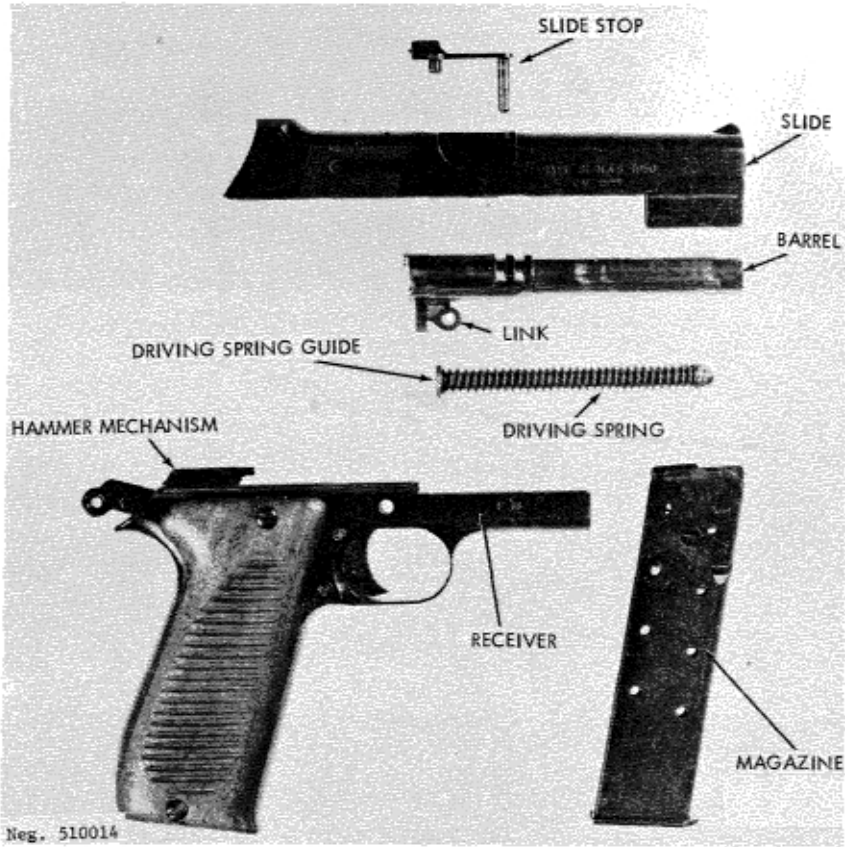

Figure 15. Model 1950 pistol, disassembled.

slide stop (fig 14), and pulling the slide rearward. Ease the slide forward until it is caught by the slide stop. Inspect to insure that no cartridges are in the barrel or slide. Pull the slide slightly rearward and ease it forward. Insert the magazine and, while holding the hammer to ease it forward, press the trigger.

22. Disassembly and Assembly

a. Clear the weapon (para 21f), but do not insert the magazine.

b. Pull the slide rearward until the slide stop (fig 14 and 15) can be pushed up into its notch in the slide. Hold the slide and pull the slide stop out to the left. Ease the slide forward and pull it off the receiver.

c. Invert the slide and remove the driving spring and guide. Lift the rear end of the barrel upward and pull it out of the slide.

d. The hammer mechanism (fig 15) can be pulled up and out of the receiver as a unit. No further disassembly is required or desirable.

e. To reassemble, invert the slide and place the barrel into the slide, muzzle end first. Insure that the barrel has dropped into the locking position with the slide and insert the recoil spring, rounded end first, into its tunnel under the slide. Press the rear end of the spring into position against the link (fig 15).

f. Replace the hammer mechanism into the receiver. Mate the ribs on the slide with the grooves in the receiver and pull the slide rearward until it is felt to stop. Look through the hole in the receiver to ascertain that the hole in the link is aligned with the hole in the receiver and insert the slide stop. Pull the slide all the way to the rear until the slide stop can be pushed up and inward to its fully seated position. Note: Occasional difficulty will be encountered in seating the recoil spring in its seat in the slide. Release the slide stop and allow the slide to go forward. Hold the hammer, press the trigger, ease the hammer forward, and insert the magazine.

23. Functioning

a. The French Model 1950 pistol is recoil operated. The barrel is locked to the slide and, upon firing, the recoil of the

barrel provides sufficient energy to unlock the barrel and drive the slide rearward, extracting the cartridge, causing ejection, and compressing the driving spring and hammer spring. The driving spring provides the power to return the slide fully forward. The firing cycle starts with the hammer cocked and a cartridge in the chamber. When the trigger is pressed, the hammer is released, rotates about its pin, and strikes the firing pin, driving it forward to fire a cartridge. The recoil of the cartridge causes the barrel to move rearward and, as it does, the rotary motion of the link pulls the rear end of the barrel down, out of engagement with the locking lugs. The slide has sufficient inertia to continue to the rear under its own power. The extractor withdraws the fired cartridge case from the chamber and holds it against the face of the slide. The cartridge case strikes a fixed ejector and pivots about the extractor as it is expelled from the gun. During this rearward movement, the driving spring is compressed and the hammer is rotated rearward to the cock position. When the slide passes by the magazine, the follower forces a new cartridge up into position.

b. The compressed driving spring drives the slide forward. The feed rib of the slide strikes the top cartridges in the magazine and drives it out of the magazine, into the barrel. The slide strikes the rear end of the barrel, driving the barrel forward. The link rotates about its pin, forcing the rear end of the barrel up into the locked position. Forward movement stops when the lug on the bottom of the barrel strikes the slide stop pin. The trigger mechanism on the Model 1950 pistol is extremely simple and is similar to that of the Model 1951 Beretta pistol (subsec C). When the hammer is cocked, pressure on the trigger causes the trigger to rotate about its pin, moving the trigger bar rearward. The trigger bar contacts a lug on the bottom of the sear and causes the sear to rotate about its pin, releasing the hammer. The hammer, under the force of the hammer spring, swings forward to fire the pistol. As the slide recoils, a cam forces the disconnecter down, shoving the trigger bar down. The trigger bar depresses sufficiently to release

the sear, which, under pressure of its spring, snaps back against the hammer. As mentioned earlier, the slide rocks the hammer rearward and, when the slide returns forward, the hammer is caught by the sear. To fire another shot, the trigger must be released to allow the trigger bar to move forward to a point where it can hop up in front of the sear. When this occurs, pressure on the trigger will then fire another shot.

c. The safety, an extremely simple mechanism, is simply a block that, when on safe, prevents the hammer from striking the firing pin. When it is rotated to the fire position, a cutaway portion on the block allows the hammer to enter into the safety bar slightly and strike the firing pin.

24. Accessories

Normal pistol accessories are found with this pistol. They include a web or leather holster, a cleaning rod, a lanyard, and spare magazines in a carrier. The lanyard is attached to the cross pin at the lower rear end of the receiver.

E. THE 9-MM M.A.B. P15 PISTOL (FRANCE)

25. General

a. The 9-mm M.A.B. P15 pistol is produced in France and is used by the French armed forces. The P15 is also sold commercially and may be found in use by the small nations and by paramilitary and police forces.

b. The P15 can be readily recognized by its large, bulky shape, thick grip, and prominent spur at the rear of the receiver. The burr type hammer is also a good identification feature.



Figure 16. French M.A.B. P15S pistol.

c. There are several versions of the P15; these include the standard model, the P15S (fig 16) and a target model, the PAP Model F1 (fig 17). The latter is identified by its target sights and tubular slide extension.

d. The P15 pistols are recoil-operated weapons with a rotary link used to lock and unlock the barrel. The unusually large double-row magazine holds 15 cartridges.

e. All P15 pistols fire 9x19-mm ammunition (sec V).

26. Technical Data

Technical data pertaining to the M.A.B. P15S will be found in table I.

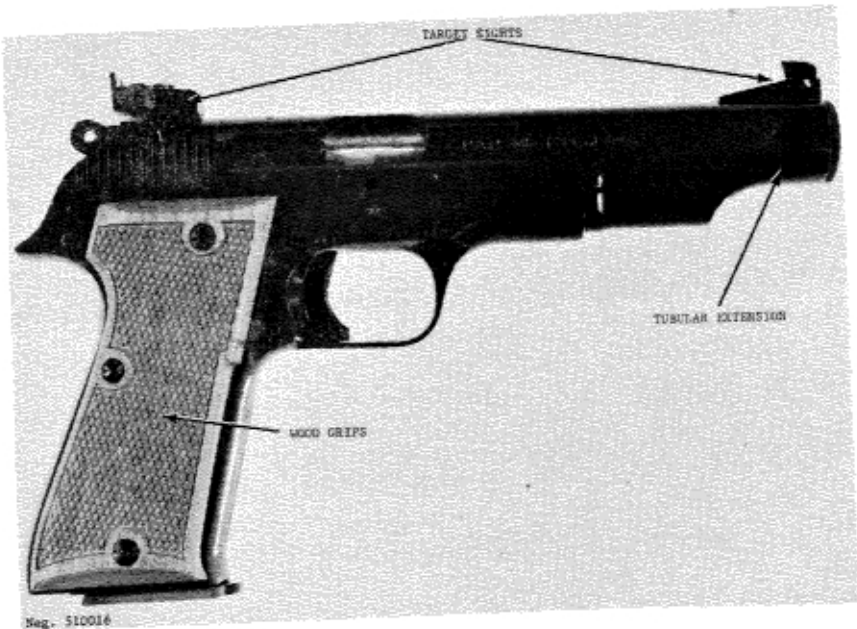

Figure 17. French M.A.B. P15- PAP Model F1.

27. Operation

a. Press the magazine catch (fig 16) and catch the magazine as it ejects. Load the magazine as described in paragraph 3b; it holds 15 cartridges. Insert a loaded magazine into the pistol until the magazine catch snaps into place and retains the magazine. The P15 has a magazine safety and cannot be fired unless the magazine is in place.

b. Grasp the slide (fig 16) and pull it fully to the rear and release it. CAUTION: The pistol is now loaded and ready to fire.

c. If the pistol is not to be immediately fired, push the safety (fig 16) up. This locks both the trigger mechanism and slide. To fire, press the safety down, aim (using a normal sight picture), and press the trigger. The pistol will fire one shot and reload itself. To fire successive rounds, release and repress the trigger. The slide will remain rearward when the last round is fired.

d. To unload or clear the P15, press the magazine catch and catch the magazine as it is expelled. Push the safety down, if necessary, and while pressing the slide stop (fig 16) upward, pull the slide fully rearward and release it. The slide stop, under normal pressure, will snap into the slide stop notch in the slide and hold it open. Inspect to insure that no cartridges are present. Press the slide stop down to allow the slide to drive forward. Insert the magazine, and press the trigger.

28. Disassembly and Assembly

a. To disassemble the P15 pistol, first clear it (para 27d) but do not insert the magazine or press the trigger. Apply strong finger pressure to the end of the slide stop pin (fig 18) and, while applying pressure, pull the slide (fig 16) about 1/4 inch to the rear. The slide stop (fig 16) will move out to the left a short distance; pull it completely out.

b. Pull the slide forward, off the receiver. Turn the slide upside down and press the driving spring guide and barrel seat (fig 18) toward the muzzle until they disengage and can be lifted out of the slide. Move the barrel (fig 18) forward about 5/16 inch, then pull it up and back until it can be lifted out of the slide.

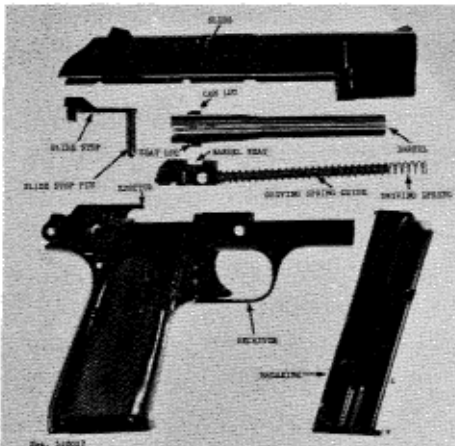

Figure 18. M.A.B. P15S disassembled.

c. No further disassembly is required or desirable.

d. To reassemble, insert the barrel into the slide, muzzle first, with the muzzle entering the hole in the front of the slide. Engage the cam lug with the cam groove in the top of the slide (fig 19). Seat the barrel fully into the slide and move the barrel back against the slide face (fig 19).

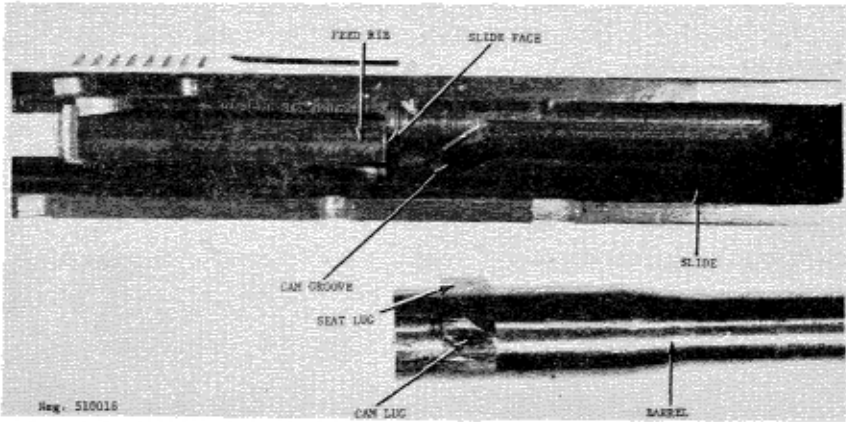

Figure 19. M.A.B. P15 barrel and slide.

e. Insert the free end of the driving spring (fig 18) into its tunnel at the front end of the slide. Press the barrel seat forward until it slips over the seat lug on the barrel (fig 18).

f. Hold the slide inverted and start the receiver onto the slide from the rear of the slide. Insert the slide stop pin into its hole (from the left side). Press the slide stop in and while applying pressure, pull the slide back slightly (about 1/4 inch) until the slide stop seats. Insert the magazine and press the trigger.

29. Functioning

a. The P15 pistol uses a hesitation lock. When the pistol is loaded and cocked, pressure on the trigger will release the hammer

and fire one cartridge. The rearward thrust of the fired cartridge drives the slide rearward; however, this rearward movement is delayed by the interaction of the cam lug on the barrel with the cam groove on the slide. The barrel seat is pinned to the receiver and engages the seat lug on the barrel (fig 19). This arrangement prevents back and forth barrel movement but does allow the barrel to rotate. The cam groove in the slide thus causes the barrel to rotate as the slide starts to recoil; this rotary motion delays the slide recoil until the gas pressure from the fired cartridge has subsided to a safe level. Residual gas pressure then drives the slide fully rearward, rocking the hammer back, compressing the driving spring and depressing the trigger bar. The extractor withdraws the fired cartridge and holds it to the slide face until the cartridge strikes the ejector (fig 18). The cartridge is then expelled out the ejection port, and when the rear of the lower part of the slide strikes the barrel seat, rearward movement ceases.



Figure 20. M.A.B. P15 section.

b. The compressed driving spring now expands and drives the slide forward. The feed rib (fig 19) drives the top cartridge out of the magazine, up the ramp on the rear of the barrel seat, and into the barrel. The cam groove then rotates the barrel and the extractor snaps into the rim of the cartridge. The trigger bar rises into its recess, and forward movement ceases.

c. The hammer, when cocked, is held by the spring-loaded sear. When the trigger is pressed, the trigger bar (fig 20) moves forward, and a hook on its rear end engages the sear (fig 20) and pulls the sear forward, out of engagement with the hammer. The hammer, under the force of the hammer spring, swings forward, strikes the firing pin, and fires the cartridge. As the slide recoils, the trigger bar is forced down, out of its recess (fig 20) and releases the sear. The sear, under pressure of its spring, snaps back against the hammer which is rocked rearward by the recoiling slide.

d. When the slide counterrecoils, the hammer is held cocked by the sear. The trigger must be released prior to firing another shot; as this occurs, the trigger bar can reenter its recess in the slide and the trigger bar hook can reengage the sear. Pressure on the trigger will now fire another shot.

e. When the safety is moved up to its safe position, a lug on the safety moves in front of the left top of the sear and blocks forward sear movement. This prevents the hammer from releasing.

f. The front end of the magazine safety (fig 20) has a hook that fits in front of the left top of the sear, preventing movement of the sear. When the magazine is fully inserted, it lifts the magazine safety out of engagement so that the trigger bar can move the sear to fire.

30. Accessories

The P15 has the usual pistol accessories: spare magazine, holster and cleaning rod.

F. THE 9-MM HECKLER AND KOCH P9 AND P9S PISTOLS (WEST GERMANY)

31. General

a. The 9-mm P9 and P9S pistols (fig 21) are among the most modern military pistols in the world. These weapons are unique because of the extensive use of pressed metal and plastic parts in their construction. The receiver, for example, is a light pressed-steel shell encased in plastic. The P9 and P9S pistols are almost identical, but the P9 has a single-action trigger whereas the P9S has a double-action trigger (refer to paragraph 1b). In addition to the slide marking differentiating the two pistols, the P9S has a small spur inside the trigger guard not present on the P9.

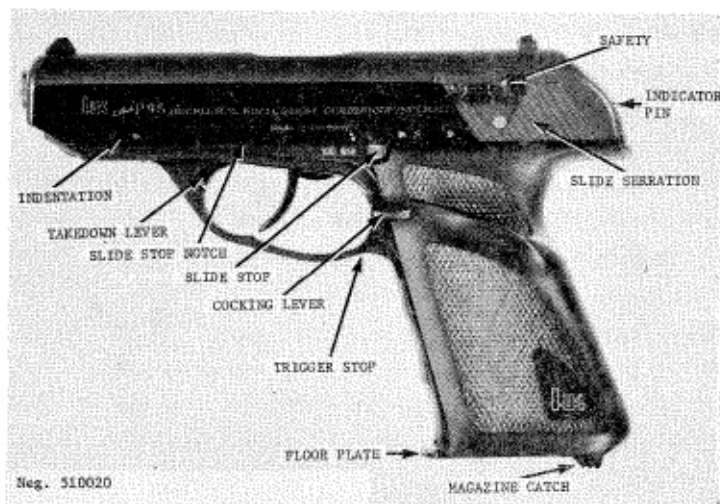

Figure 21. West German P9 pistol.

b. The P9 and P9S are roller-locked, recoil-operated semiautomatic pistols fed from nine-round capacity box magazines. Both weapons have internal hammers which can be cocked by an external cocking lever. An adjustable trigger stop in the rear of the trigger guard permits easy refinement of the trigger pull.

c. The P9 and P9S pistols are not presently used by any army, but they are offered for sale and may be expected to be used by paramilitary and police units.

d. The P9 and P9S fire the 9x19-mm cartridge; refer to section V.

32. Technical Data

Technical data pertaining to the P9 and P9S pistols are given in table I.

33. Operation

a. Press the magazine catch (fig 21) to the rear with the left thumb and, using the left index finger hooked over the magazine floor-plate, pull the magazine out of the pistol. Load the magazine as described in paragraph 3b. Insert the loaded magazine into the pistol until the magazine catch snaps into place and retains the magazine.

b. Rotate the safety (fig 21) downward as far as possible; then grasp the slide by its serrations (fig 21), pull it rearward as far as possible, and release it. The pistol is now loaded. The extractor will protrude from the bolt, indicating by sight and feel that there is a cartridge in the chamber. The indicator pin also protrudes from the rear of the receiver below the slide. At this point, the pistol can be fired or rendered fully safe.

c. To render the pistol fully safe, grasp it in the right hand and use the right thumb to fully depress the cocking lever (fig 21) and hold it depressed. Use the left thumb to rotate the safety up to the fire position, press the trigger, then ease the cocking lever upward. The indicator pin will retract into the slide, indicating that the hammer is no longer cocked. Rotate the safety fully downward.

d. To fire, if the indicator pin is protruding, rotate the safety fully upward, aim (using a normal sight picture), and press the trigger. The pistol will fire one shot and reload itself. To fire successive rounds, release and repress the trigger for each round. The slide will remain to the rear after the last cartridge in the magazine has been fired.

e. To fire, if the indicator pin is not protruding, rotate the safety upward, then fully depress the cocking lever (fig 21) and release it. Aim and fire as described in paragraph d above.

f. If the pistol is a P9S and the indicator pin is not protruding, the weapon can be cocked and fired as described in the preceding paragraph or, after rotating the safety upward, the trigger can be pressed over its full travel to cock automatically and release the hammer. This pistol then will function normally after the first round has been fired.

g. To clear or unload, rotate the safety downward, press the magazine catch to the rear, and withdraw the magazine. Press the cocking lever (fig 21) upward and draw the slide to the rear where it will be caught by the slide stop (fig 21). Inspect to insure that no cartridges are present, then depress the cocking lever fully to release the slide. Rotate the safety upward, depress the cocking lever, press the trigger, and ease the cocking lever up. Rotate the safety down and insert the magazine, unloading it first if necessary.

34. Disassembly and Assembly

a. Clear the pistol (para 33g) but do not insert the magazine. Press the takedown lever (figs 21 and 22) into the trigger guard and push the slide forward; then lift it up, off the receiver.

b. Press the barrel forward in the slide against the force of the driving spring until the rear end of the barrel can be eased up and out of the slide. Remove the barrel and driving spring.

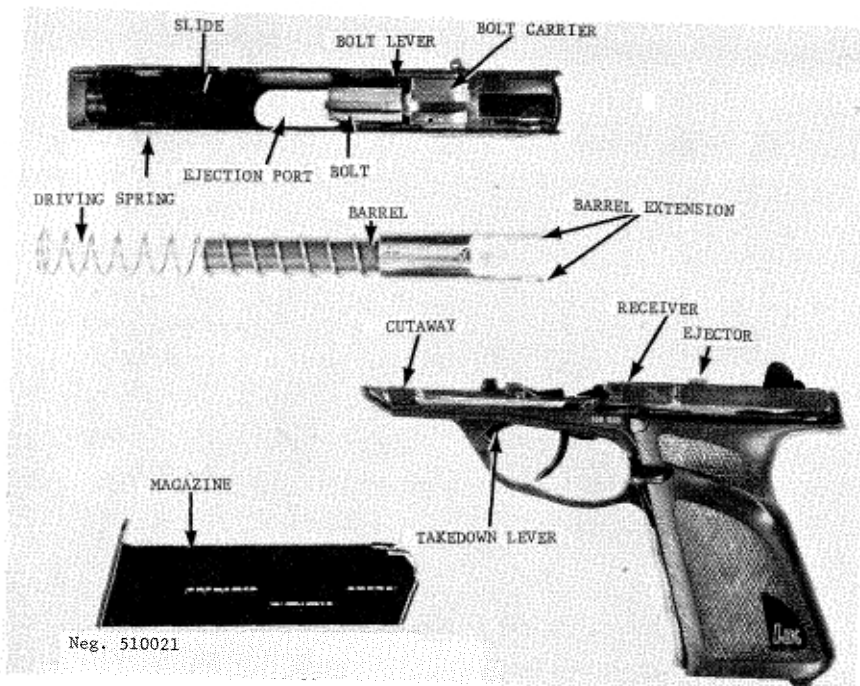

Figure 22. P9 disassembled.

c. Normally no further disassembly is required; however, if desired, the bolt (fig 22) can be removed from the slide. To do so,

insert one of the barrel extensions into the slide, just forward of the bolt carrier (fig 22), and press the barrel down to release the bolt lever (fig 22). Press the bolt forward, off the bolt carrier. No further disassembly should be attempted.

d. To reassemble the pistol, place the bolt (if disassembled) into the slide with its extractor or rounded side toward the ejection port (fig 22) and start it onto the bolt carrier. Use the barrel extension to depress the bolt lever and push the bolt fully onto the bolt carrier. Remove the barrel extension and push the bolt forward until it clicks into place.

e. Insert the barrel and driving spring into the slide (driving spring first) and insure that the spring is seated in its recess around the inner front of the slide. Rotate the barrel so that its rounded side is toward the ejection port (fig 22); then press the barrel forward into the slide, against the force of the driving spring, until the barrel seats into the slide. Ease the barrel rearward so that the extensions fit alongside the bolt.

f. Place the slide on the receiver so that the indentations in the slide are aligned with the cutaways (fig 22) in the receiver. Press the slide down on the receiver, then pull the slide rearward and release it. Clear the pistol as described in paragraph 33g.

35. Functioning

a. The P9 pistols are operated by delayed blow-back. When the pistol is loaded and cocked, pressure on the trigger releases the firing pin, and the cartridge is fired. The rear thrust of the cartridge, upon firing, is transmitted to the bolt and, via the rollers, to the barrel extension (fig 21). The rollers effectively lock the bolt (and slide) to the barrel. The angle on the locking cam (fig 21) does allow the rollers to cam out of their recesses and to move into the bolt as the rearward thrust of the cartridge

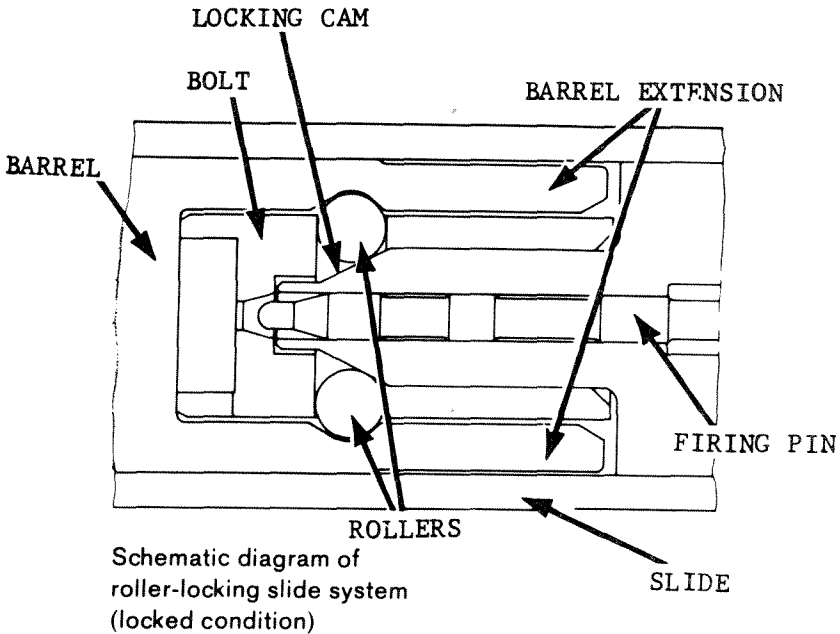

Neg. 510022

Figure 23. P9 bolt functioning.

continues and, when the rollers are fully into the bolt, the bolt and slide are then unlocked from the barrel and can move rearward. The bolt lever snaps into the bolt and holds the bolt forward in its unlocked position. The delay occasioned by the rollers' retraction allows gas pressure to drop to a safe level. The rearward thrust of the case has given enough momentum to the slide to drive it fully rearward. This rearward movement compresses the driving spring and rocks the hammer back (fig 24). The extractor holds the fired cartridge case against the bolt until the cartridge case strikes the ejector (fig 22); the case is then expelled out through the ejection port. The rearward movement stops when the inside front of the slide strikes the buffer; the driving spring then drives the slide forward. The feed rib on the bolt drives the top cartridge out of the magazine and into the

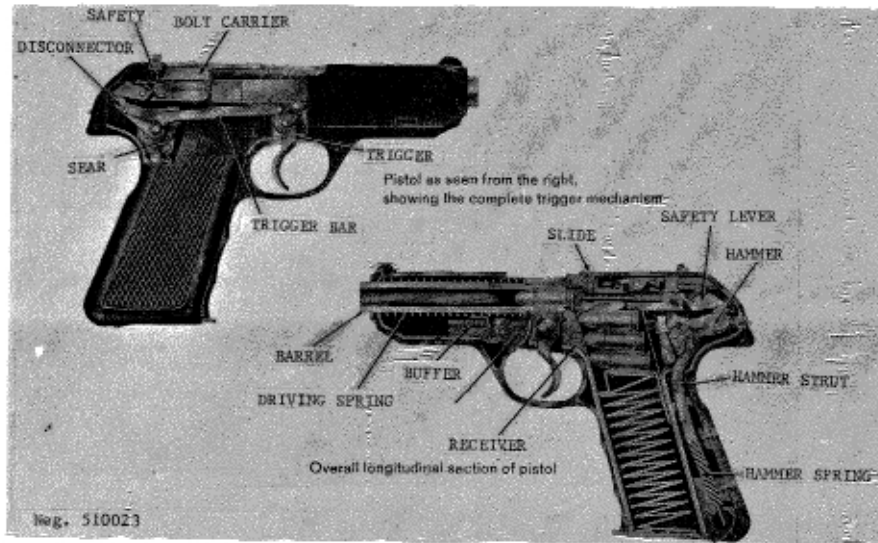

Figure 24. P9 trigger mechanism functioning.

barrel. As the bolt enters the barrel extension, a cam on the edge of the extension forces the bolt lever out of engagement with the bolt; this permits the bolt to be driven back onto the bolt carrier. As the bolt moves onto the carrier, the locking cam forces the rollers outward, thus relocking the barrel to the bolt.

b. When the trigger is pressed, the trigger moves the trigger bar forward (fig 24). The trigger bar moves the sear from engagement with the hammer, which, under force of the hammer spring, swings forward and strikes the firing pin, firing the cartridge. As the slide recoils upon firing, the disconnector (fig 24) is forced out of its recess in the slide, and the front end of the disconnector moves upward. This upward movement allows the trigger bar spring to move the rear of the trigger bar up, out of engagement with the sear. The released sear snaps back against the hammer. When the slide counterrecoils, the sear engages the hammer and holds it cocked. Upon completion of the slide's forward movement, the disconnector moves back into its recess in

the slide. When the trigger is released, the trigger bar moves forward until it drops down into engagement with the sear. Pressing the trigger will now fire another shot.

c. The P9S double-action trigger can cock and release the hammer (by pressing the trigger through its entire travel). As the trigger is pressed, it causes the trigger bar to move forward, and (on the P9S only) a pull-lever moves with the trigger bar. The pull-lever actuates intermediate lever on the left side of the pistol; this lever, in turn, causes the main cocking arm to pivot about its pin. The main cocking arm fits over the hammer strut and causes it to move, compressing the hammer spring and rocking the hammer rearward. As the trigger nears the end of its rearward travel, a cam on the receiver lifts the pull-lever out of engagement with the intermediate lever. When the intermediate lever is released, the hammer spring drives the parts back to their starting position, and the hammer thus strikes the firing pin. The pistol's trigger mechanism then functions as described in paragraph b above.

d. The cocking lever (fig 21), when depressed, acts upon the left side of the main cocking arm and causes the arm to rotate on its pin, forcing the hammer strut down to compress the hammer spring and cock the hammer. When the cocking lever is released, a spring returns it upward, and the main cocking arm then returns to its original position. The sear, however, has engaged the hammer and holds it cocked. Pressure on the trigger will now initiate the actions described in paragraph b above.

e. The cocking arm also fits under the top shoulder of the slide stop (fig 21). Upward pressure on the cocking arm will force the slide stop up to engage the slide stop notch (fig 21) and hold the slide open. A bottom shoulder on the slide is engaged when the cocking arm is depressed. This forces the slide stop down and releases the slide.

f. The safety, when applied, causes the safety lever (fig 24) to move and force the disconnecter out of its recess in the slide. The front end of the disconnecter rises and allows the trigger bar to rise out of engagement with the sear. When the safety is rotated to the fire position, the safety lever allows the disconnecter to move into its recess and reestablish the connection between the trigger bar and sear.

g. The indicator pin (fig 21) is loosely attached to the hammer. As the hammer rotates rearward, a pin on the side of the hammer causes the indicator to move rearward; this same pin pulls the indicator in when the hammer is forward.

h. A shoulder on the magazine follower contacts the slide stop and, when the last cartridge is fed from the magazine, the magazine spring (acting through the follower) forces it up to engage the slide. When the magazine is removed and the slide retracted, the follower spring forces the follower down.

36. Accessories

a. The P9 and P9S are usually issued with an extra magazine and an L-shaped screwdriver. The screwdriver is used to turn the various screws that secure the receiver's plastic cover and to adjust the trigger stop.

b. The trigger stop is located in the rear of the trigger guard (fig 21). To adjust it, loosen the screw at the right rear of the guard and push the stop up into the guard about 1/4 inch. Cock the hammer and press the trigger. If the hammer does not fall, move the trigger stop slightly back into the guard until it does. When the trigger pull is satisfactory, retighten the screw. Use of the trigger stop prevents the P9S from being fired in the double-action mode.

3 February 1984

G. THE 9-MM MODEL 49 (SIG P210) PISTOL
SWITZERLAND)

37. General

a. The Swiss Model 49 pistol (fig 25) is the military version of the Swiss SIG P210 pistol. They differ only in finish and grips; the P210 has a highly polished blue finish and wood grips, whereas the Model 49 has a dull, sandblast finish and plastic grips. A target version is also produced, and sporting models in 7.65-mm and .22 caliber are also available. The Model 49 pistol is recoil operated and semiautomatic, feeding from an eight-round magazine.

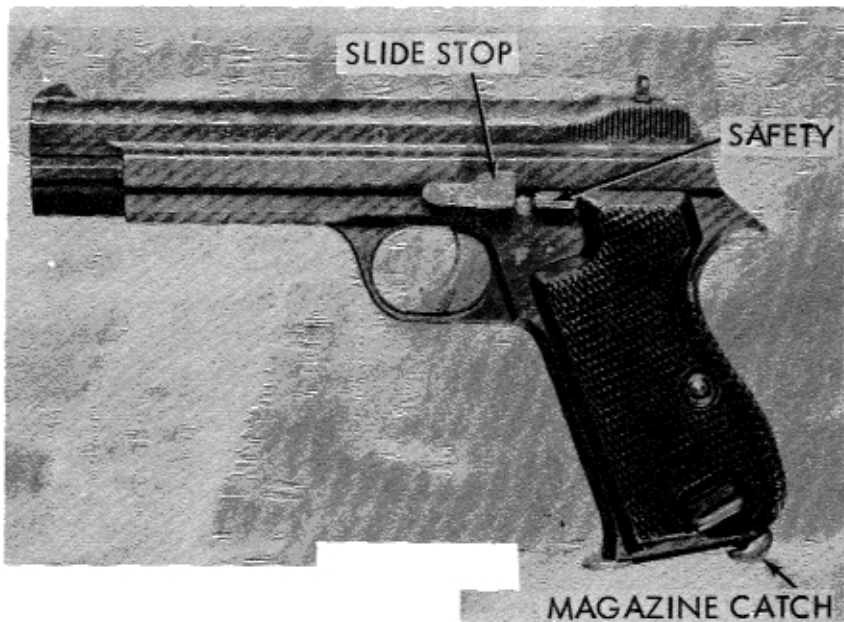

Neg. 510024

Figure 25. Swiss Model 49 (SIG P210) Pistol

b. The Model 49 was the standard side arm of the Swiss Army, and some have been used by the West German Border Guards. Because the pistol is a commercial item, it can be found in at least limited use by several other armies.

3 February 1984

c. The Model 49 fires 9x19-mm pistol cartridges (sec V); however, by changing only the barrel and driving spring, 7.65x19-mm cartridges can be fired. It can also be converted to fire .22 LR by changing the barrel, return spring, slide, and magazine.

38. Technical Data

Technical data concerning the Model 49 (SIG P210) will be found in table I.

39. Operation

a. Remove the magazine by pressing the magazine catch (fig 25) rearward, away from the magazine, and withdrawing the magazine. Load the magazine as described in paragraph 3b. It will hold eight cartridges.

b. Push the safety (fig 25) upward to the safe position. Insert the loaded magazine into the pistol until the magazine catch snaps into place. Pull the slide fully to the rear and release it. CAUTION: The pistol is now loaded.

c. To fire, press the safety down, aim (using a normal sight picture), and squeeze the trigger. The pistol will fire one shot; to fire successive shots, release and resqueeze the trigger. After the last round in the magazine is fired, the slide will remain to the rear. The slide can be released by either pressing down the slide stop (fig 25) or, after removing the magazine (a above), by pulling the slide rearward and releasing it.

d. Clear the pistol by pressing the safety upward (to safe), and then removing the magazine (a above). Then pull the slide rearward while pressing up the slide stop (fig 25) until the stop moves up into its notch in the slide. Inspect through the ejection port to insure that no cartridges are present, then press down the

slide stop to release the slide, move the safety downward, and press the trigger. Move the safety back to safe and insert the magazine.

40. Disassembly and Assembly

a. Clear the pistol (para 39d), but do not reinsert the magazine. Hold the pistol in the right hand and, after pulling the slide back about one-quarter inch, hold it in this position by wrapping the right-hand fingers over the slide. Press in on the right end of the slide stop shaft (fig 25 and 26) until the slide stop moves sufficiently to the left to clear the slide. Release the slide and pull the slide stop to the left, out of the pistol.

b. Pull the slide forward, off the receiver. Invert the slide and pull the rear end of the driving spring guide (fig 26) up, out of engagement with the barrel. Grasp the barrel at the cam lug (fig 26), pull up and rearward to remove.

c. Pull the hammer mechanism (fig 26) upward, out of its seat in the receiver.

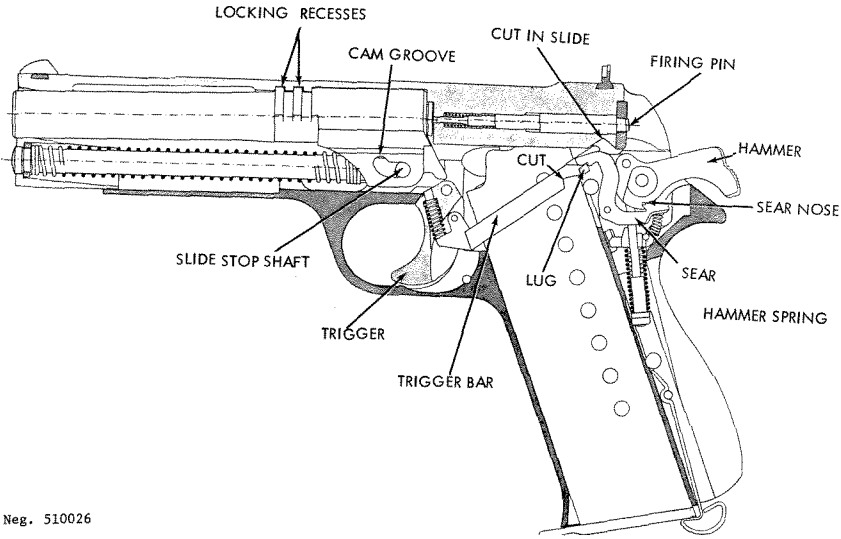

Figure 26. M49 pistol, disassembled.

- d. Further disassembly is not necessary or advisable.
- e. To reassemble, insert the hammer mechanism back into its seat in the receiver.
- f. Insert the muzzle end of the barrel into the hole in the front of the slide, then seat the rear end of the barrel into position within the slide. Seat the driving spring against its seat in the front of the slide and force the driving spring guide (fig 26) forward against pressure of the spring until the guide can be seated in the cam lug of the barrel.
- g. Align the rails at the bottom of the slide with the grooves at the top of the receiver and move the slide rearward until it stops. Pull the slide farther rearward slightly, against spring pressure, and insert the shaft of the slide stop (fig 26) into its hole from the left. Seat the slide stop fully; it may be necessary to slightly move the slide back and forth to allow the slide stop to seat. Insert the magazine.

41. Functioning

- a. The Swiss M49 pistol is recoil operated (refer to paragraph 5a). When the weapon is loaded and the hammer is cocked, pressure on the trigger causes it to rotate about its pin and move the trigger bar (fig 27) rearward. The rear end of the trigger bar moves into a cut in the slide, and a lug on the rear contacts the sear (fig 27) to cause it to pivot. The sear nose disengages from the hammer (fig 27) which, under the force of the hammer spring, swings forward and strikes the firing pin to fire the cartridge.
- b. The barrel and slide, locked together, recoil as a unit to compress the driving spring and rock the hammer back. The slide stop shaft fits into the cam groove on the barrel (fig 27) and, as



Neg. 510026

Figure 27. M49 pistol, section.

the barrel recoils, the cam groove, acting on the slide stop shaft, causes the rear end of the barrel to move down out of engagement with the locking recesses. The barrel stops, but the slide, because of its inertia, continues rearward.

c. The extractor pulls the fired cartridge case out of the chamber and holds it to the slide until the ejector expels the fired case out through the ejection port. The slide finally strikes a shoulder in the receiver and stops its rearward movement.

d. The driving spring forces the slide forward, and the feed rib drives the top cartridge out of the magazine and into the barrel. The slide drives the barrel forward, and the barrel cam, working on the slide stop shaft (fig 27), forces the barrel up into engagement with the locking ribs of the slide.

e. When the slide recoils, it depresses the rear end of the trigger bar (fig 27). The trigger bar lug then disengages from the

sear; the sear, powered by the sear spring, snaps against the hammer. The hammer is rocked back by the recoil of the slide and, upon counterrecoil, is held cocked by the sear engaging with the sear notch of the hammer (fig 27).

f. To fire again, the trigger must first be released. This causes the trigger bar to move forward to a point where it can rise by pressure of its spring, and its lug reengages the sear. Pressure on the trigger will initiate another cycle.

g. The safety, when set to safe, has a shoulder that swings into a cut on the trigger bar (fig 27) and prevents rearward movement of the trigger bar. The weapon thus cannot be fired.

h. The magazine follower has a lip that engages the slide stop when the last round is fed out of the magazine. The upward pressure on the slide stop forces it up so that it snaps into its cut on the slide and holds the slide open.

42. Accessories

a. Several accessories are available for the M49 pistol. These include:

- (1) Leather holster
- (2) Spare magazines and carrier
- (3) Magazine loader
- (4) Cleaning kit
- (5) Front-sight pusher
- (6) .22 caliber conversion units.

3 February 1984

b. The magazine loader is slipped over the back of the magazine. By forcing the loader down, the follower spring will be depressed enough to permit a cartridge to be slid under the feed lips. The loader is moved upward to prepare for loading the next round and the cartridge fully seated.

c. The front-sight pusher is a "C"-shaped device equipped with a thumbscrew. This device is placed over the slide along the front sight, and, after the screw is aligned with the front sight blade, the screw is turned to move the front-sight blade for zeroing. This tool should be used by an armorer only.

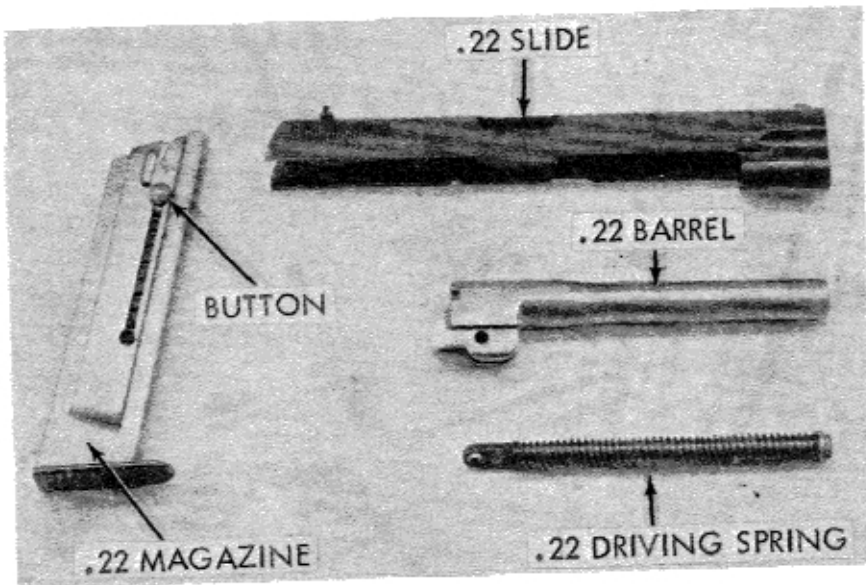

Neg. 510027

Figure 28. M49 Pistol .22 Caliber Conversion Unit

3 February 1984

d. The .22 caliber conversion unit (fig 28) consists of a slide, barrel, driving spring assembly, and magazine. The 9-mm pistol is disassembled and, when reassembled (para 40) with the conversion unit parts, can fire .22 long-rifle ammunition for training purposes. The .22 magazine has a button on its right side that, when depressed, lowers the follower for ease in loading cartridges.

G.1 THE 9-MM MODEL 75 (SIG-SAUER P210) PISTOL (SWITZERLAND)

42.1. General

a. The Swiss Model 75 pistol (fig 28.1) is the military version of the Swiss SIG P210 pistol. The Model 75 is produced only in Switzerland for use by the Swiss Armed Forces. The Model 75 has a dull finish and plastic grips, and can be identified by the marking "SIG" on the left side of the slide. The SIG P210 is produced in Switzerland and West Germany for commercial sales; it has a polished blue finish and wood or plastic grips, and can be identified by the marking "SIG SAUER" on the left side of the slide. The P210 is also being produced in .45 ACP and 7.65-mm PARA. The hammer dropping safety (fig 28.1) is a recognition feature for all models. A firing pin safety prevents the loaded pistol from firing unless the trigger is deliberately pulled. The Model 75 is short-recoil operated, fires semiautomatic, and feeds from a nine-round-capacity box magazine.

b. The Model 75 was adopted as the standard sidearm for the Swiss Army in 1975, and designated as the 9-mm Pistol 75.

c. The Model 75 fires the 9x19-mm pistol cartridge; refer to section V.



Neg. 527780

Figure 28.1. Swiss 9-mm Model 75 Pistol

42.2. Technical Data

Technical data pertaining to the Model 75 and the SIG-SAUER P210 are found in table 1.

42.3. Operation

a. Remove the magazine by pressing the magazine catch (fig 28.1) rearward, away from the magazine, and withdraw the magazine. Load the magazine as described in paragraph 3b. It will hold nine cartridges. Insert the loaded magazine into the pistol until the magazine catch snaps into place and retains the magazine.

3 February 1984

b. Grasp the slide (fig 28.1) by its milled grooves and pull it fully to the rear and release it to feed a round into the chamber. CAUTION: The pistol is now loaded and ready to fire.

c. A firing pin lock (the safety slide) (fig 28.1.1) renders the pistol safe. The pistol cannot be discharged accidentally if the cocked hammer snaps forward. It can be fired only by pulling the trigger. If the weapon is not to be fired immediately, the cocked hammer should be lowered by pressing the hammer dropping safety (fig 28.1) downward to release the hammer forward until the sear engages the safety notch of the hammer.

d. To fire, aim (using a normal sight picture), and squeeze the trigger. The pistol will fire one shot and reload itself. To fire successive rounds, release and repress the trigger. The slide will remain rearward when the last round is fired.

e. To clear the pistol, remove the magazine (a above), and, while pressing up on the slide top lever (fig 28.1), pull the slide to the rear until the lever engages the slide stop notch (fig 28.1) in the slide and holds it open. Inspect to insure that no cartridges are present in the chamber or slide. Press down on the slide stop lever to release slide forward. Press the trigger, and insert the magazine.

54.1

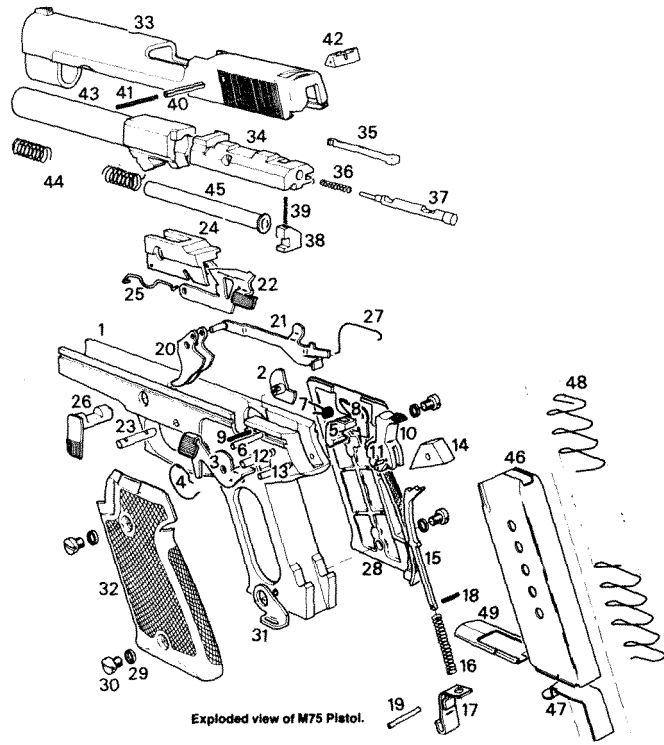

Exploded view of M75 Pistol.

- | | |
|-----------------------------|---------------------------|
| 1. Frame | 25. Slide catch spring |
| 2. De-cocking lever seating | 26. Dismantling lever |
| 3. De-cocking lever | 27. Trigger spring |
| 4. De-cocking lever spring | 28. Right hand grip plate |
| 5. Sear | 29. Washer |
| 6. Sear pin | 30. Grip plate screw |
| 7. Torsion spring for sear | 31. Strap ring |
| 8. Safety lever | 32. Left hand grip plate |
| 9. Spring pin | 33. Slide |
| 10. Hammer | 34. Rear insert |
| 11. Hammer pin | 35. Extractor |
| 12. Hammer axle | 36. Firing pin spring |
| 13. Pin for stop | 37. Firing pin |
| 14. Stop | 38. Safety slide |
| 15. Hammer spring stirrup | 39. Safety slide spring |
| 16. Main spring | 40. Outer spring pin |
| 17. Magazine catch | 41. Inner spring pin |
| 18. Hammer spring pin | 42. Rear sight |
| 19. Magazine catch pin | 43. Barrel |
| 20. Trigger | 44. Recoil spring |
| 21. Trigger rod | 45. Recoil spring tube |
| 22. Slide catch lever | 46. Magazine casing |
| 23. Trigger pin | 47. Feeder |
| 24. Locking insert | 48. Magazine spring |
| | 49. Magazine base plate |

Neg. 527781

Figure 28.1.1. Swiss 9-mm Model 75 pistol, exploded view.

42.4. Disassembly and Assembly

a. To disassemble the Model 75 for cleaning:

(1) Clear the weapon (para 42.3e), but do not insert the magazine.

(2) Retract the slide while pressing up on the slide stop lever (fig 28.1) until the lever engages in the slide stop notch (fig 28.1).

(3) Rotate the takedown lever downward (fig 28.1) 90°. Pull the slide slightly rearward until the slide stop lever drops, and ease the slide forward until it is free of the receiver.

(4) Turn the slide over. Grasp the driving spring and guide with one hand and the slide in the other. Press the spring and guide (fig 28.1.2) with one hand and the slide in the other. Press the spring and guide toward the muzzle of the barrel until they clear the notch on the barrel lug. Let the spring expand, and ease the spring and guide up and out of the slide (fig 28.1.3).

(5) Grasp the barrel lug, and, while lifting, pull the barrel forward until it frees itself. Lift out.

(6) No further assembly is necessary or desirable.

b. To reassemble the pistol:

(1) Insert the barrel into the inverted slide until it falls into place.

(2) Place driving spring and guide into receiver, and press until driving spring guide can be placed into the notch on the barrel lug.



Neg. 529266

Figure 28.1.2. Model 75 pistol disassembled.

54.3

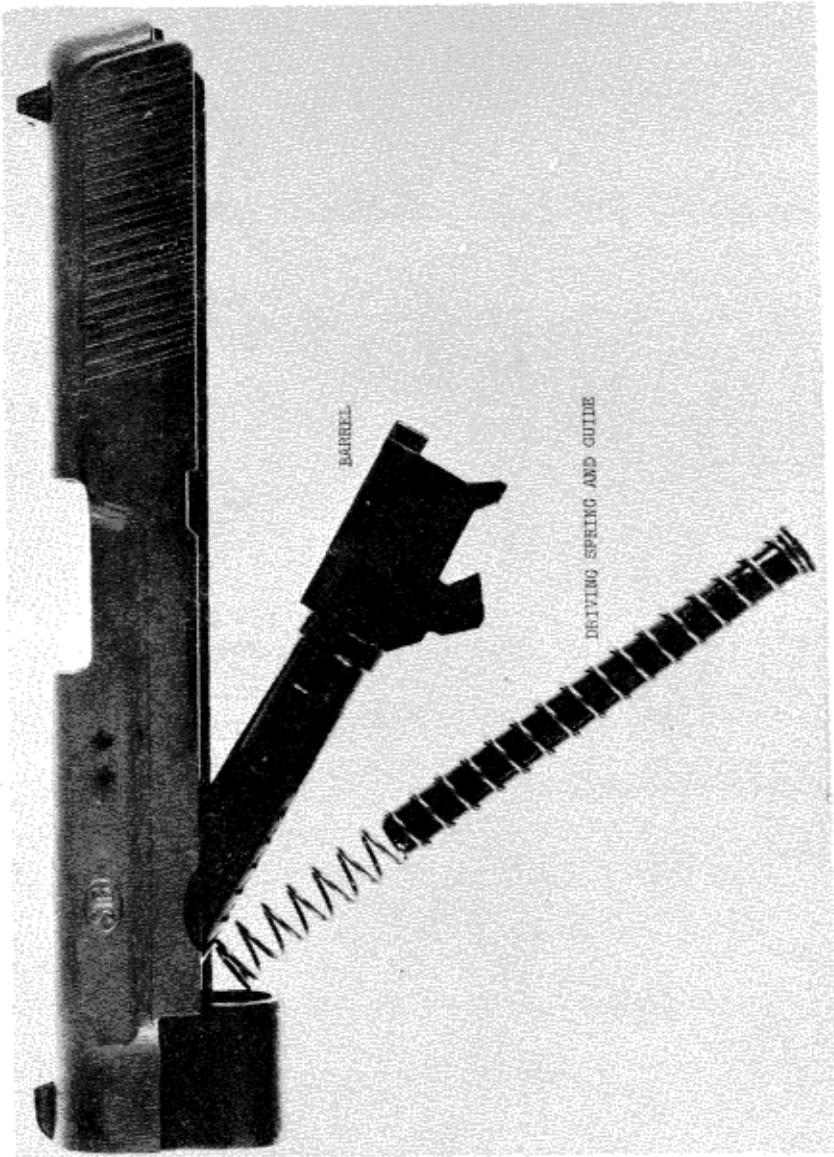

Neg. 529267
Figure 28.1.3. Removal of driving spring and barrel from Model 75 pistol.

(3) Cock hammer.

(4) Align rear of slide with the side grooves on the front of the receiver. Push slide back onto receiver, while pushing up on the slide stop lever, until slide is held to rear. Rotate the takedown lever 90° upward.

(5) Release the slide, squeeze the trigger, and insert the magazine.

42.5. Functioning

a. The Swiss M75 is recoil operated (refer to paragraph 5a). When the pistol is loaded and ready to fire, it can be fired by double action or single action of the hammer and trigger mechanism. Refer to figure 28.1.1 for nomenclature and parts relationship.

b. With the hammer in its forward position, finger pressure on the trigger moves the trigger rod forward. The shoulder on the trigger rod engages the notch in the bottom of the hammer and causes the hammer to rotate back. When the trigger rod is almost at the limit of its forward travel, the sear is moved away from the hammer, and the firing pin is released by the rotation of the spring-loaded safety lever, which pushes the safety locking slide (fig 28.1.1-38) through the firing pin. By continual pressure on the trigger, the trigger rod moves forward and the cam on the side rear of the rod comes in contact with the hammer pin, forcing the rod down, releasing the hammer. The hammer spring pin (fig 28.1.1-18) swings the hammer to fire the cartridge.

c. Single action is accomplished by cocking the hammer by hand or by rearward slide movement. Pressure on the trigger will move the trigger rod (fig 28.1.4 and 28.1.5) forward. As the trigger rod nears the point where it will lift the sear (fig 28.1.4) from the hammer notch, it rotates the spring-loaded safety lever (fig 28.1.1-8), which rises under the firing pin (fig 28.1.1-37) and pushes the safety locking slide (fig 28.1.1-38) through the firing pin, which is then free to go forward when struck by the hammer.



Neg. 529269

Figure 28.1.4. Model 75 trigger mechanism, cocked.



Neg. 529268

Figure 28.1.5. Model 75 trigger mechanism, at rest.

d. The barrel and slide, locked together, recoil for about 3 mm. After this free travel (to allow the chamber pressure to drop to a safe level), the barrel (28.1.1-43) unlocks from the slide. The unlocking surface under the barrel strikes the cam

surface at the front of the operating cam (fig 28.1.1-24) and the rear of the barrel is forced down, unlocking it from the slide. The slide continues rearward by inertia. The trigger rod is forced down when the disconnecter cam cut on the side of the recoiling slide depresses the vertical arm of the trigger rod. This disconnects the shoulder on the trigger rod from the safety lever arm, which then frees the sear to snap back, where it can engage the hammer and hold it cocked.

e. The fired cartridge is held to the breech face by the extractor until it is thrown out through the ejection port in the top of the slide. The hammer is rocked back by the recoiling slide. The rear of the driving spring tunnel on the slide strikes the face of the operating cam, stopping the rearward movement of the slide.

f. The driving spring now expands and drives the slide forward. As the slide moves forward, the feed rib drives a cartridge out of the magazine and into the chamber. The extractor snaps into the rim of the cartridge. The safety locking slide (fig 28.1.1-38) engages and locks the firing pin. The sear, under pressure of its spring, engages the sear notch in the hammer and holds the hammer cocked.

g. The barrel lug surface under the barrel rides up the slope on the rear of the operating cam and slides forward an additional 3 mm along the flat top of the cam. This action fully supports the rear end of the barrel, and locks it to the slide. Forward movement stops when the barrel lug strikes the takedown lever shaft.

h. When the slide returns forward and the trigger is released, the trigger rod moves rearward and up into the disconnecter cam cut on the side of

the slide. The shoulder on the trigger rod can now engage the rear of the safety lever arm, and, by repressing the trigger, another shot can be fired.

i. To fire another shot, the trigger must be released. The trigger rod moves rearward, allowing the hook on the rear of the trigger rod to engage the notch on the back portion of the hammer. Trigger pressure, when reapplied, will fire another shot.

j. A ledge on the magazine follower pushes the slide stop lever upward when the last round is fed from the magazine. The stop then automatically holds the slide open.

42.6. Accessories

A leather holster, leather magazine holder with spare magazine, and a cleaning rod and oiler in a canvas carrier are provided as accessories (fig 28.1.6).

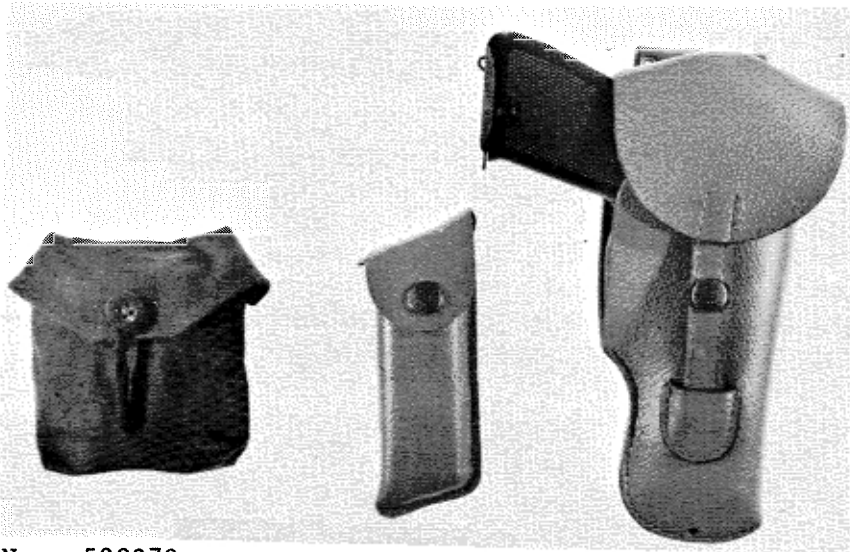

Neg. 529270

Figure 28.1.6. Swiss Model 75 pistol with (from left to right) cleaning kit, spare magazine carrier, and holster.

H. MISCELLANEOUS PISTOLS

42.1.1 General

a. Some pistols, because of their relative scarcity, or newness, do not warrant full coverage in this guide, but must be included for identification purposes. This group includes the Spanish Super Star and West German VP-70 pistols.

b. Occasionally a pistol of World War II or earlier vintage will be encountered. Information on these older weapons is readily available in standard reference texts such as Ezell's Small Arms of the World.

42.2.1 The Spanish 9-mm Super Star Pistol

a. The 9-mm Super Star pistol (fig 28.1) is the standard sidearm of the Spanish Army and is offered for commercial sale by its manufacturer. The Spanish Army version fires the 9x23-mm Largo cartridge. The commercial versions usually fire the 9x19-mm cartridge.

b. The Super Star resembles the US pistol, cal. .45 M1911A1; however, the Super Star does not have a grip safety, and the trigger rotates rather than slides. The Super Star is operated, disassembled, and reassembled in the same ways as in the US Army cal. .45 M1911A1 pistol. The Super Star can be identified by the markings on its slide.



Figure 28.2.1. The Spanish 9-mm Super Star pistol.

42.3.1 The West German 9-mm VP-70 Pistol.

a. The Heckler and Koch Company produces the VP-70 pistol in West Germany, and, while it has not been adopted by any army, it is offered for commercial sales and may be used by the armies of some smaller nations. The VP-70 is a large, blowback-operated semiautomatic pistol (fig 28.2.2) with the unique feature of having a holster-stock that, when attached to the pistol (fig 28.2.3), permits firing in three-shot bursts at a cyclic rate of fire of 2200 shots per minute.

b. The VP-70 can be identified by its squat outline, angular, plastic holster-stock with selector, and double-action-only trigger mechanism.



Figure 28.2.2. The West German 9-mm H&K VP-70 machine pistol.

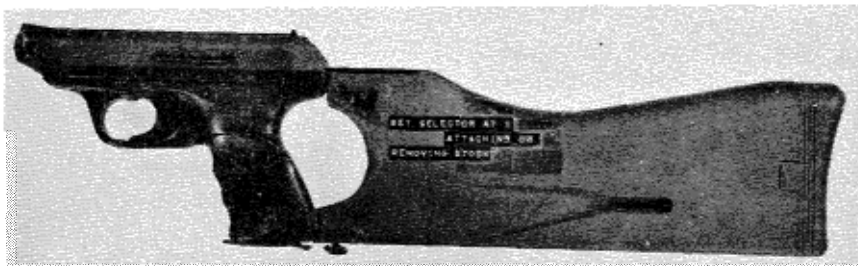

Figure 28.2.3. The VP-70 with holster-stock attached.

42.4.1. The Japanese 9-mm Model 57A Pistol

a. The 9-mm Model 57A pistol (fig 28.2.4) is a design based on that of the US M1911A1 caliber .45 pistol. This weapon is in limited production and fires the 9x19-mm cartridge.



Neg. 528899

Figure 28.2.4. The Japanese 9-mm Model 57A pistol.

b. The Model 57A can be identified by either its nomenclature stamped into the left side of the slide or its resemblance to the US caliber .45 M1911A1 pistol. The M57A differs from the latter in that it has no grip safety, is of a smaller caliber, and has a magazine release button on the lower left side of its grip.

42.5.1. The Japanese 7.65-mm Model 57B Pistol

a. The 7.65-mm Model 57B pistol (fig 28.2.5), while sharing most of its nomenclature with the M57A pistol, is an entirely different weapon, and it fires the 7.65x17SR cartridge. It is also in limited production.



Neg. 528898

Figure 28.2.5. The Japanese 7.65-mm Model 57B pistol.

b. The M57B can be identified by either the markings on the left side of its slide or the rounded front slide, partially concealed hammer, and odd trigger angle. The magazine catch is at the bottom rear of the grip.

I. MAINTENANCE

43. Care and Cleaning

The procedures and materials prescribed for cleaning standard US Army pistols also apply to foreign pistols. These weapons should be disassembled only to the extent necessary for adequate cleaning to prevent breakage and subsequent loss of use. No repairs should be attempted on foreign pistols except for replacement of parts, which should be done only by a competent armorer.

44. Malfunctions and Stoppages

Most malfunctions and stoppages are caused by defective magazines or ammunition. Malfunctions caused by broken or worn parts can be corrected by replacing the defective part with a serviceable one. This should be done only by a competent armorer, and the repaired weapon must then be function test-fired. Table II lists common problems and their remedies.

★ Table I. Pistol Technical Data

Weapon	Pistole P1	FN Browning Hi Power	Beretta Model 1951	M.A.S. Model 1950	M.A.B. P15	P9 P9S	SIG Model 49	SIG Model 75
								SIG SAUER P210
Caliber (mm)	9x19	9x19	9x19	9x19	9x19	9x19	9x19	9x19
Length (mm)	214	203	203	195	203	193	215	198
Weight, empty (kg)	0.69	0.86	0.71 ²	0.82	1.08	0.88	0.90	0.74
Barrel length (mm)	125	118	115	112	116.8	102	120	112
Magazine capacity (rd)	8	13	8	9	15	9	8	9
Operation	Short recoil	Short recoil	Short recoil	Short recoil	Short recoil	Delayed blowback	Short recoil	Short recoil
Fire-type	Semi- automatic	Semi- automatic	Semi- automatic	Semi- automatic	Semi- automatic	Semi- automatic	Semi- automatic	Semi- automatic
Muzzle velocity (m/s) ¹	350	350	350	350	350	350	350	345
Practical range (m)	50	50	50	50	50	50	50	50
Rate of fire (rd/min)	35	40	35	35	40	35	35	Single shots

¹May vary from 340 to 400 m/s, depending upon ammunition.

²Aluminum alloy receiver; 0.875 kg with steel receiver.

Table II. Pistol Malfunctions

Condition	Cause	Remedy
Fails to fire (cartridge in chamber)	Defective cartridge	Reload
Fails to fire (no cartridge in chamber)	Defective magazine	Replace magazine
Fails to extract or eject	Fouled weapon	Clean and lubricate

SECTION II. SUBMACHINEGUNS

A. THE 9-MM L2A3 AND L34A1 SUBMACHINEGUN GUNS (UK)

45. General

a. The 9-mm L2A3 submachinegun (fig 29) is currently the standard submachinegun in the British Army. A commercial version, the Sterling Mk4, is offered for export sales, and a slightly modified version, the C1 submachinegun, is produced in Canada for use in the Canadian Armed Forces. A silenced version, the L34A1 (fig 30), is used by the British Army and is also offered for commercial sale. All versions, both military and commercial, can be found in use throughout the British Commonwealth and former colonies.

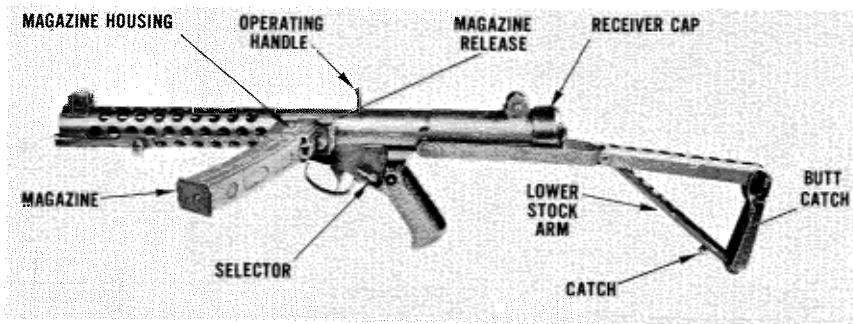

Neg. 510028

Figure 29. British L2A3 submachinegun.

b. The L2 series submachineguns are readily recognized by their cylindrical receiver, sharply pitched grip, and left-extending horizontal magazine. The silenced versions are identified by their long, unperforated jackets (fig 30). All are selective-fire, blowback-operated, box-magazine-fed

weapons equipped with folding metal stocks. The L2A3, Mk4, and C1 versions have a boss and a lug for a bayonet on the lower left front of the barrel jacket. Early versions (the "Patchett", L2, L2A1, and L2A2) may differ in details from the guns described, but, in general, the information given is applicable to all. The L2A3, C1, L34A1, and commercial versions fire the 9x19-mm pistol cartridges (sec V).

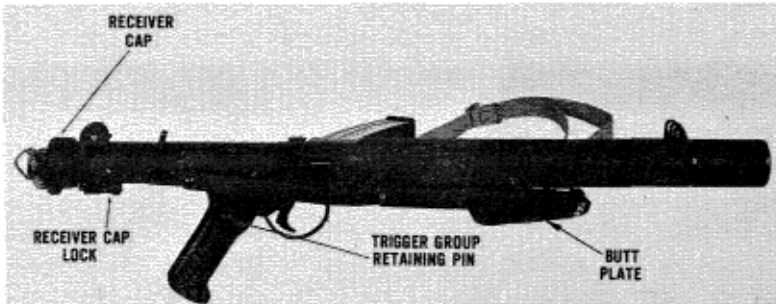

Neg. 510029

Figure 30. British L34A1 silenced submachinegun.

46. Technical Data

Technical data concerning the L2A3 submachinegun are given in table III.

47. Operation

a. The instructions given generally apply to all models. Reference will be made only to L2A3 unless otherwise indicated.

b. The L2A3 can be fed from its normal 34-round magazine, from the Canadian 10- or 32-round magazines, from the obsolete Sten 32-round or Lanchester 50-round magazines. If the L2A3 or C1 magazines are used (preferably), place a cartridge on the follower and press downward until the cartridge rolls under the feed lip; repeat until the magazine is full. If the Sten or Lanchester magazines are used, place the cartridge in front of the feed lips, press down and slide rearward until the cartridge base strikes the rear wall of the receiver. Repeat until the magazine is

full. These latter magazines are difficult to fill, and loading can be facilitated by using a 1/4-inch, short-blade screwdriver to depress and hold down the preceding cartridge prior to inserting another cartridge.

c. Rotate the selector (fig 29) rearward to S position. Insert a loaded magazine into the magazine housing (fig 29) until the magazine release snaps into place.

d. If the stock is folded, unfold by pulling the rear of the butt plate away from the jacket and then swinging the butt fully rearward. Press the receiver cap lock (fig 30) and snap the stock against the receiver; receiver cap will hold the stock in place. Pull the butt plate down to open the stock fully. To fold the stock, press the butt catch (fig 29) against the inner wall of the butt plate and push the lower stock arm (fig 29) upward. Press the receiver cap lock (fig 30) and force the receiver cap forward until the stock is freed. Rotate the stock forward until it is under the barrel jacket; press the stock firmly against the jacket and lift the butt plate until the catch (fig 29) engages the hole in the jacket. Tap the butt plate firmly against the stock.

e. Rotate the selector (fig 29) to either the A or R position (A for full automatic; R for repeat or semiautomatic). Pull the operating handle fully rearward, then ease it forward until the bolt is caught. If the gun is not to be immediately fired, rotate the selector to S. Flip the rear sight to the desired range, 100 or 200 meters. (The L34A1 sight, in either position, is set for only 100 meters.) Rotate the selector to A or R, aim (using a normal sight picture), and press the trigger. The gun will fire one shot if the selector is on R; the trigger must be released and repressed to fire a succeeding shot. If the selector is set at A, the gun will fire as long as the trigger is held and cartridges are in the magazine. CAUTION: Except in emergencies, fire the L34A1/Mk5 in the semiautomatic mode only! When the last round is fired, the bolt

will close on an empty chamber. Press the magazine release (fig 29) and pull the empty magazine straight out of the gun.

f. To clear the gun, remove the magazine by pressing the magazine release (fig 29) and pulling the magazine out of the gun. Retract the operating handle until it is caught to the rear. Inspect to insure that no cartridges are present, hold the operating handle, press the trigger, and ease the bolt forward. Rotate the selector rearward to safe and reinsert the magazine.

48. Disassembly and Assembly

a. Clear the weapon (para 47f) before starting disassembly, but do not rotate the selector to safe or reinsert the magazine.

b. Press the receiver cap lock (fig 30), push the receiver cap forward, and rotate it counterclockwise. When the receiver cap lugs disengage, ease the cap rearward and remove it. Pull the operating handle rearward until it aligns with the circular hole at the end of its slot. Pull the handle outward to remove it. Pull the driving spring unit out. Remove the bolt by placing a hand over the open rear end of the receiver, elevating the muzzle, and pressing the trigger.

c. If desired, rotate the head of the trigger group retaining pin (on the pistol grip) (fig 30) so that the slot aligns with the "FR EE" marking; then pull the pin out. Pull the trigger group rearward and swing its front end up and out of the gun.

d. No further disassembly is necessary or desired.

e. To reassemble, first engage the lip at the front end of the trigger group with its seat in the receiver, then swing the rear end into place. Push the trigger group forward to fully seat it; then

insert the trigger group retaining pin, seat it fully, and turn its slot so that it aligns with the "LO CK" marking.

f. Insert the bolt into the receiver with the large cutaway portion at the front, aligned with the magazine housing (fig 29). Press the trigger and push the bolt forward; it may be necessary to twist the bolt to align it with the ejector. Move the bolt rearward until the hole for the operating handle mates with the hole in the end of the operating handle slot. Insert the operating handle, concave surface forward, then press the trigger and slide the bolt fully forward. Insert the driving spring unit into the receiver, small end leading (if a dual spring). Place the receiver cap over the end of the spring, depress the receiver cap lock (fig 30), and press the cap forward over the receiver. The cap must mate with its seat so that it can be twisted clockwise and locked.

g. The silencer of the L34A1 (Mk 4) submachinegun should not be disassembled because special tools are required to disassemble and reassemble the silencer unit. When cleaning the L34A1 barrel, use a minimum amount of cleaning solvent and oil in the barrel; an excess of either will decrease the silencer's efficiency and cause excessive smoke when firing.

49. Functioning

a. The L2 series submachineguns are blowback-operated and fire from the open-bolt position. When a loaded magazine is in place, the bolt is held cocked by the sear, and the selector is moved off the safe position; pressure on the trigger will release the bolt from the sear. The driving spring then drives the bolt forward and the feed rib, on the bolt, pushes the top cartridge out of the magazine and into the barrel. The extractor snaps into the groove of the cartridge and the fixed pin strikes the primer to fire the cartridge. The weight and inertia of the bolt holds the fired cartridge case in place until the bullet leaves the muzzle and propellant gas pressure subsides. The rearward thrust of the fired

cartridge, however, is sufficient to overcome the weight and inertia and to force the bolt rearward against its driving spring.

b. The fired cartridge drives the bolt rearward and compresses the driving spring. The extractor holds the fired case against the bolt face until the case strikes the fixed ejector located in the rear of the magazine housing; the case is then expelled out the ejection port. When the bolt ceases its rearward movement, the driving spring forces the bolt forward to commence another firing cycle.

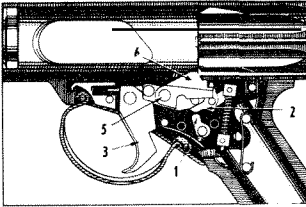

COCKED

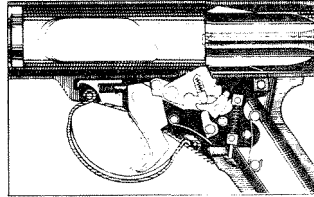

TRIGGER PRESSED

SEMIAUTOMATIC FIRE

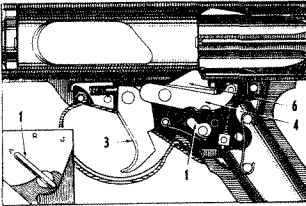

COCKED

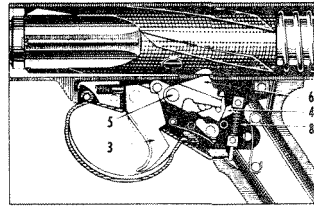

TRIGGER PRESSED

AUTOMATIC FIRE

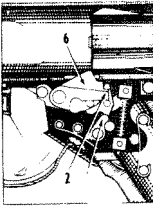

SAFE

Neg. 510030

- 1 SELECTOR AND SHAFT
- 2 DISCONNECTOR
- 3 TRIGGER
- 4 SEAR CARRIER
- 5 SEAR AND SEAR CARRIER PIN
- 6 SEAR
- 7 SEAR CARRIER BEARING
- 8 DISCONNECTOR SPRING

Figure 31. L2A3 submachinegun, section.

c. The type of fire is determined by rotating the selector lever; this action changes the position of a lug on the selector shaft in relation to the disconnecter (fig 31). The sear and disconnecter are mounted on a spring-loaded sear carrier. The roughly L-shaped disconnecter is spring loaded so that its nose will engage a shoulder at the rear of the sear. The lower arm of the disconnecter extends forward under the sear and over the selector shaft. A shoulder on the rear of the pivoted trigger bears on the front of the sear carrier (fig 31).

d. When the selector is rotated to the A (automatic fire) position, the lug on the selector shaft swings forward out from under the disconnecter (fig 31). As the trigger is pressed, the trigger shoulders bear against the sear carrier and force the sear carrier to rotate on its pin; the rear end of the sear carrier depresses. The disconnecter is pinned to the rear of the sear carrier and moves with it. The disconnecter nose is also engaged with the sear and, as the sear carrier moves, the disconnecter causes the sear (which also is pivoted on the sear carrier pin) to depress and release the bolt. The weapon will continue to fire until the trigger is released to allow the sear carrier, disconnecter, and sear to rise up so the sear can intercept the bolt and stop the firing cycle.

e. When the selector is turned to the R (repeat or semiautomatic) position, the lug on the selector shaft moves under the lower front of the disconnecter. As the trigger is pressed, it causes the sear carrier, disconnecter, and sear to rotate, as in automatic fire (d above), to release the bolt. As pressure on the trigger continues to cause the sear carrier to rotate, the disconnecter strikes the lug on the selector shaft (fig 31). This causes the disconnecter to pivot on its pin (in the sear carrier), and the disconnecter nose releases the sear (fig 31). The sear spring immediately forces the sear upward to intercept the bolt and stop the firing cycle after a single round has been fired. To fire a second shot, the trigger must be released to allow the rear of the sear

carrier to rise. The disconnecter rises (with the sear carrier) until its nose snaps into the shoulder in the sear (fig 31). Pressure on the trigger will now cause another shot to be fired.

f. When the selector is rotated rearward to S (safe), the lug on the selector shaft moves rearward, under the rear end of the disconnecter (fig 31). With the lug thus blocking the downward movement of the disconnecter, the sear cannot be depressed. Because the sear cannot be depressed, the bolt will be locked in position by the sear engaging the sear notch if the bolt is cocked or, if it is uncocked, the safety notch at the rear of the bolt (fig 31).

50. Accessories

Few accessories are used in conjunction with the L2 series submachineguns. The accessories usually available include web carrying slings, extra magazines, magazine carrier, and either cleaning rods or pull-through cords for cleaning the barrel.

B. THE 9-MM UZI SUBMACHINEGUN (ISRAEL)

51. General

a. The 9-mm UZI submachinegun (fig 32 and 33) was designed by an Israeli Army officer in the early 1950's. The design appears to have been influenced by the Czechoslovak M-23 submachinegun. However, the UZI has several novel features for a submachinegun, including a bayonet and a spigot-type grenade launcher. The UZI is a simple gun to manufacture, using a maximum amount of stamped metal parts, and is considered to be an extremely reliable weapon.

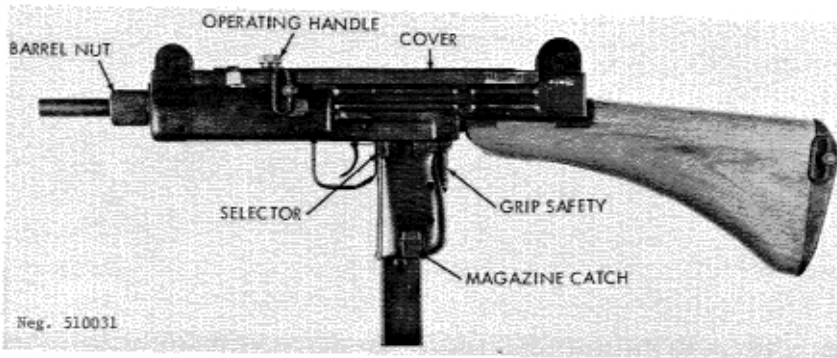

Figure 32. Israeli UZI submachinegun, early model.

b. The UZI, which has been manufactured in Israel and Belgium, is a standard weapon in Israel, West Germany, and the Netherlands. It also is offered commercially. The No. 2 Mark A guns used by the Israeli Army can be identified by the Hebrew characters used to identify the selector settings; the German MP1 and the Dutch guns use "D", "E", and "S" for these markings, while export or commercial models are marked "A", "R", and "S".

c. Like most submachineguns, the UZI fires from an open bolt and can be fired either automatically or semiautomatically. It is fed by 25- or 40-round-capacity box magazines inserted into the pistol grip. Although the UZI is usually equipped with a folding metal butt (fig 33), a wood butt (fig 32), in at least two different lengths, is also used.

d. All UZI submachineguns fire the 9x19-mm pistol cartridge (sec V).

52. Technical Data

Technical data concerning the UZI submachineguns are given in table III.

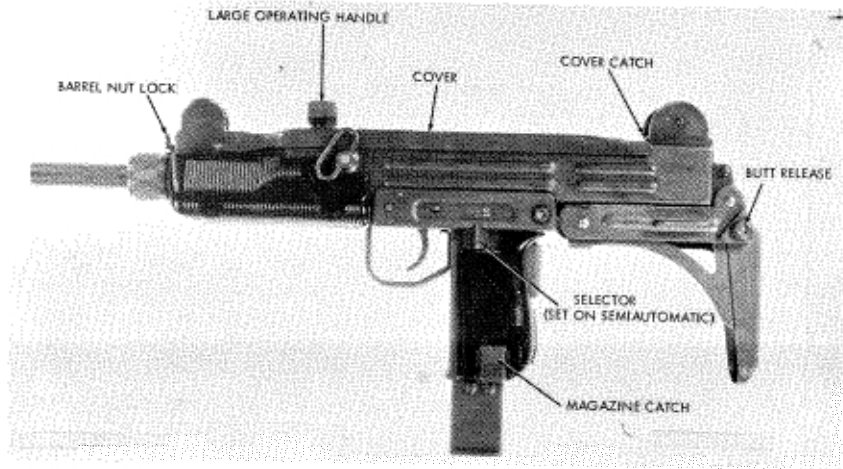

Figure 33. UZI submachinegun, late model with folding butt.

53. Operation

a. Load the magazine by placing a cartridge between the feed lips and pressing downward until the cartridge rolls to the side and under one of the feed lips. Repeat until the magazine is full.

b. If the gun is a folding stock model, press the butt release (fig 33), pull down on the butt plate, and unfold the butt. To fold the butt, squeeze the rear half together, just to the rear of the joint, and fold the stock down and forward, insuring that it locks to the receiver.

c. Insert the magazine into the bottom of the butt until the magazine catch snaps into place. After pressing the grip safety (fig 32), pull the operating handle fully to the rear and release it. CAUTION: The UZI is now loaded and ready to fire. If the gun is not to be immediately fired, slide the selector (fig 32) fully rearward to the "safe" position.

d. To fire the UZI, flip the rear sight to the desired range (100 or 200 meters) and slide the selector to either the semiautomatic (middle) or the full automatic (forward) position. Using a normal sight picture, aim, depress the grip safety, and press the trigger. The gun will fire according to the selector setting; after the last round is fired, the bolt will remain forward.

e. Remove the magazine by pressing the magazine catch (fig 32 or 33) and pulling the magazine out of the gun.

f. To clear the gun, remove the magazine (e above), set the selector forward, depress the grip safety, and pull the operating handle to the rear. Look into the ejection port to insure that no cartridges are present. Pull the operating handle to the rear again and, while holding it, press the grip safety and trigger. Ease the operating handle forward, set the safety to safe, and insert the magazine.

54. Disassembly and Assembly

a. To disassemble the UZI, clear the gun (para 53f), but do not set it on safe or insert the magazine.

b. Press in the cover catch (fig 33) and lift the cover (fig 33) from the receiver. Pull the bolt slightly rearward; then swing its front end up and out of the receiver. Separate the bolt and driving spring from the receiver and then from each other.

c. Press in the barrel nut lock (fig 33) and unscrew the barrel nut; pull the barrel (fig 34) forward and out of the receiver.

d. To assemble the weapon, insert the barrel into the receiver and turn the barrel until it seats. Replace and tighten the barrel nut so that there is no fore or aft play in the barrel. Place the driving spring and guide into the bolt and, with the cut out of

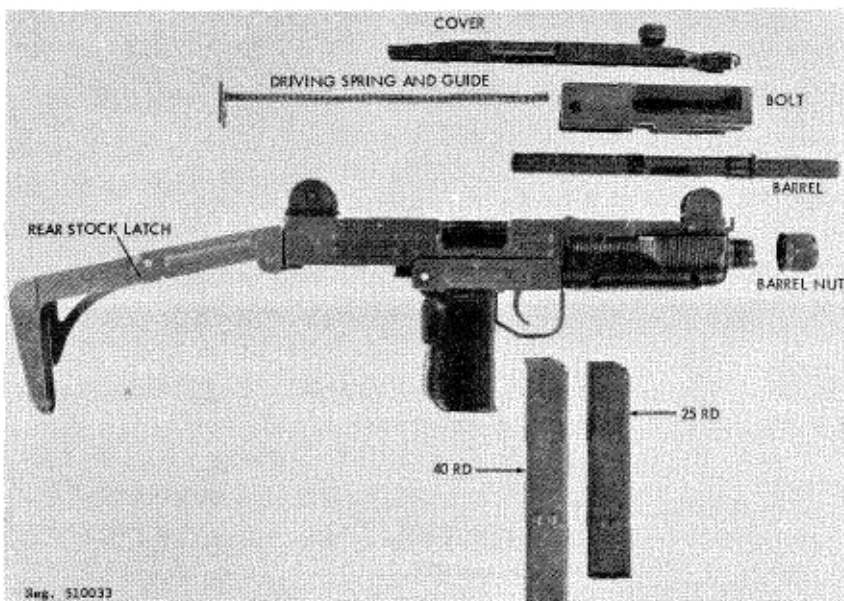

Figure 34. UZI submachinegun, field stripped.

the guide down and the guide seated against the rear receiver wall, swing the bolt back down into place.

e. Insert the front of the cover (fig 34) under the front sight and press the rear end of the cover down until the cover snaps into place. Reinsert the magazine.

55. Functioning

a. The UZI is blowback operated and fires from the open-bolt position.

b. As the trigger is pressed, the disconnecter (fig 35) pinned to the front extension of the trigger pulls the sear out of engagement with the bolt, and the bolt, under the force of its driving spring, starts forward; the feed rib of the bolt forces the

top cartridge out of the magazine and into the chamber. As the cartridge seats in the chamber, the extractor snaps over the cartridge rim, and the fixed firing pin strikes the primer to fire the cartridge.

c. The fired cartridge blows the bolt back and compresses the driving spring. The extractor holds the fired cartridge case to the bolt face until the case strikes the fixed ejector (fig 35) in the bottom of the receiver; the case is then expelled through the ejection port. The driving spring forces the bolt forward again to continue the firing cycle.

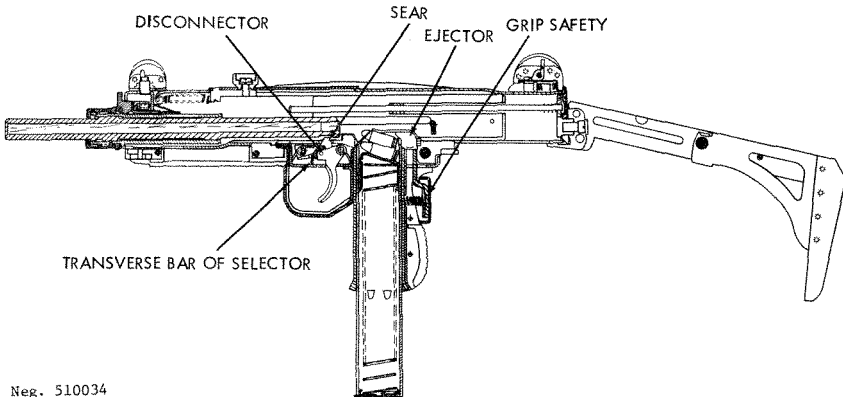

Neg. 510034

Figure 35. UZI submachinegun, section.

d. When the selector is in the forward (automatic) position and the trigger is pulled, the sear is depressed, and the gun continues to fire until the trigger is released or the magazine is empty.

e. When the selector is in the middle (or semiautomatic) position, the transverse bar of the selector (fig 35) slips under the front of the disconnecter. When the trigger is pressed, the

disconnecter depresses the sear to release the bolt, but as the disconnecter contacts the bar of the selector, the disconnecter rocks rearward and releases the sear. Under the force of the sear spring, the sear moves upward and intercepts the bolt, thus firing only one shot. The trigger must be released to allow the disconnecter to rise and reengage the sear for another shot.

f. When the selector is moved to its rearmost or safe position, the bar moves under the front end of the trigger and prevents the trigger from being pulled.

g. When the grip safety is at its normal position, a shoulder in the forward extending bar fits under a lug on the right side of the sear. This prevents the sear from being depressed. The grip safety must be pressed in to move its shoulder forward from under the sear, which then can be depressed and allow the gun to be fired.

h. The sear extends up into cuts in the bolt when the bolt is forward, and, unless the grip safety is pressed to unlock the sear, the bolt is locked forward and cannot be cocked.

56. Accessories

a. In addition to the normal accessories (spare magazines, magazine carriers, and web slings), the UZI has a bayonet, a grenade launcher, and an accessory clip for joining two magazines.

b. The bayonet is affixed by mating the dovetail slot in the handle with the lug under the gun, just behind the barrel nut. The bayonet is removed by pressing its catch and pulling it forward.

c. The grenade launcher is attached by removing the barrel nut (para 50b) and replacing it with the grenade launcher. **CAUTION:** Do not insert a magazine into the gun when a grenade is in place on the launcher.

(1) Open the bolt and place the special blank cartridge into the chamber. (CAUTION: Never use a bulleted cartridge.) Place the selector on safe.

(2) Hold the UZI horizontal and slide the grenade (only 22-mm inside-diameter tail boom grenades) onto the launcher. Remove the safety pins if necessary.

(3) Using the ogive of the grenade as the sight, aim, press the selector forward, and squeeze the trigger and grip safety.

(4) If possible, avoid using a folding stock UZI for launching grenades.

d. The accessory clip snaps around the bottom of two magazines and holds them in an "L" shape. This permits rapid reloading.

C. THE 9-MM M.A.T. MODEL 1949 SUBMACHINEGUN (MAT-49) (FRANCE)

57. General

a. The French 9-mm M.A.T. Model 1949 submachinegun (fig 36) is standard in the French Army and in many of the armies of former French colonies. These guns are also used by the Viet Cong and other guerrilla forces in Asia and Africa.

b. The M.A.T. 49, which has a folding magazine housing and a prominent grip safety, is readily recognized by its rectangular receiver and perforated, cylindrical, barrel jacket. The M.A.T. 49 has a sliding wire stock and a dust cover over its ejection port.

c. The M.A.T. 49 fires 9x19-mm ammunition (sec V).

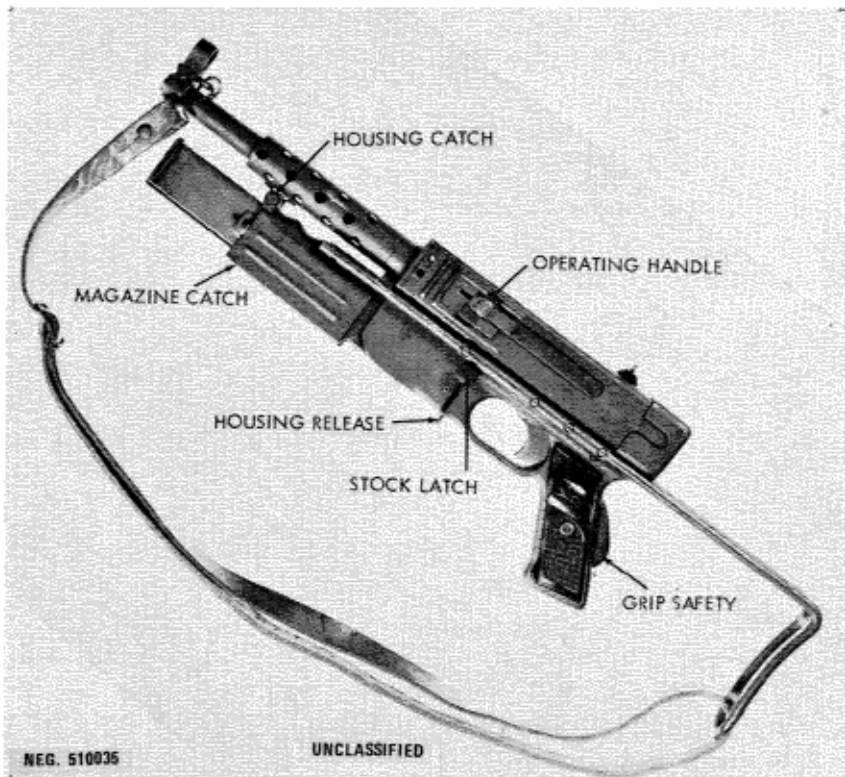

Figure 36. French M.A.T. 49 submachinegun.

58. Technical Data

Technical data concerning the M.A.T. 49 submachinegun are given in table III.

59. Operation

a. Load the magazine as described in paragraph 47 for the Sten or Lanchester magazines. Place a cartridge on the follower with the cartridge base just ahead of the feed lips; press the cartridge down, against the force of the follower spring, and slide it rearward under the feed lips. After several cartridges have been

loaded and the magazine spring has been compressed, loading additional cartridges is difficult. A screwdriver with a 1/4-inch-wide blade can be used to aid loading. After each round is inserted into the magazine, place the edge of the screwdriver into the groove of the cartridge and press down. This will depress the follower and cartridges sufficiently to allow a fresh cartridge to be inserted under the feed lips without having to overcome the force of the magazine spring.

b. If the magazine housing is folded forward, press the housing catch (fig 36) and swing the magazine housing down until it is vertical and until the release located on the underside of the trigger housing (fig 36) engages the magazine housing. Insert the loaded magazine into the housing until it is caught by the magazine catch. Depress the grip safety and pull the operating handle (fig 36) to the rear; then push the handle back to its forward position. CAUTION: The gun is now ready to fire.

c. If the ejection port cover is open, swing it forward to close the port and to keep out dirt. The cover will open automatically when the bolt moves forward upon firing.

d. There is no manual safety, as such, on this weapon, but the magazine and its housing can be swung forward under the barrel (fig 36). This action, which is the only manual safety feature, also renders the gun more compact. Press the release under the trigger housing and swing the housing and magazine forward until the housing catch locks to the bracket under the barrel jacket. The magazine and housing must be swung into position before firing (para b above).

e. Press the stock latch (fig 36) and slide the stock to either the opened or closed position.

f. Set the rear sight for the desired range (100 or 200 meters) by flipping it forward or rearward. Using a normal sight

picture, aim, depress the grip safety, and squeeze the trigger. The gun will fire as long as the trigger is pressed and ammunition is present. The bolt will remain closed when the last round is fired.

g. Remove the magazine by depressing the magazine catch (fig 36) and pulling the magazine straight out of the magazine housing.

h. To clear the M.A.T. 49, remove the magazine and swing the magazine housing forward (para c and d above). Depress the grip safety and retract the operating handle. Look into the ejection port to insure that no cartridges are present. Hold the operating handle, depress the grip, and press the trigger; then ease the bolt forward. Close the ejection port cover and insert the magazine into the magazine housing.

60. Disassembly and Assembly

a. To disassemble the weapon (fig 37), clear the submachinegun (para 59f) and release the magazine housing from the barrel jacket (para 59b), but do not latch it to the receiver. Press in the knurled take-down button under the rear end of the barrel jacket. Swing the barrel and receiver assembly upward, off the trigger frame. The bolt and driving spring can be removed through the sear of the receiver. No further disassembly is required or desirable.

b. To reassemble the gun, insert the bolt and driving spring into the receiver. Insert the rear of the receiver into the cap at the rear end of the trigger frame, lower the front end of the receiver, and push it rearward into the frame until the frame and receiver lock together.

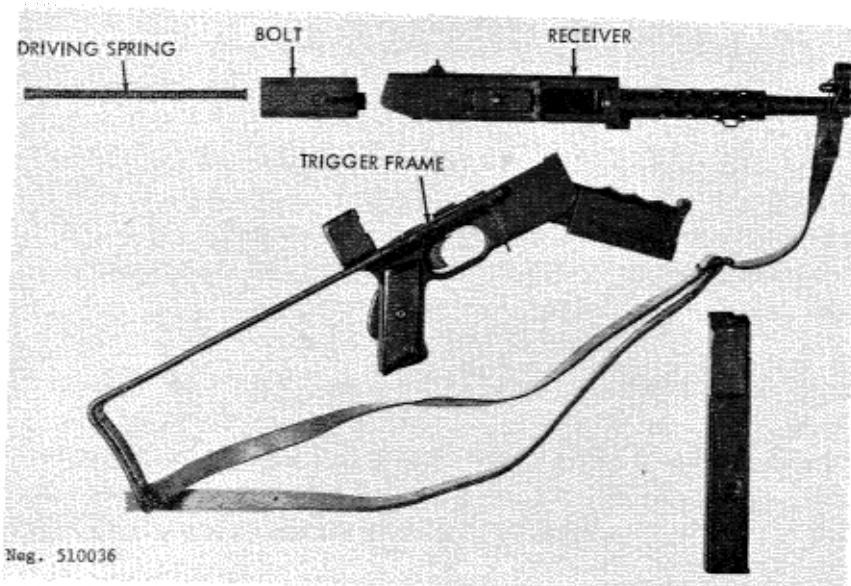

Figure 37. M.A.T. 49 disassembled.

61. Functioning

a. The M.A.T. 49 is blowback operated. When a loaded magazine is in place and the bolt is cocked, pressure on the trigger moves the sear out of engagement with the bolt. The compressed driving spring drives the bolt forward; the feed rib on the bottom of the bolt drives the top cartridge from the magazine and into the barrel. As the bolt continues forward, the extractor snaps over the rim of the cartridge, the firing pin (machined into the bolt face) strikes the primer, and the cartridge fires.

b. The fired cartridge drives the bolt rearward and compresses the driving spring. The extractor holds the cartridge case to the bolt until the case strikes the ejector; the case is then expelled through the ejection port. The firing cycle continues until the trigger is released or the magazine is emptied.

c. The grip safety performs two functions: It locks the trigger, and, if the bolt is forward, it is locked in that position.

When the grip safety is depressed, it pivots around its pin, and a small lug behind the trigger swings up to release the trigger. At the same time, a linkage attached to the left top of the grip safety depresses a lock located to the left of the sear; this lock must be depressed to allow the bolt to move rearward. This mechanism prevents accidental firing if a gun with loaded magazine in place is dropped on the butt. Otherwise, inertia could move the heavy bolt to the rear, a cartridge could be stripped from the magazine, and the weapon could be fired.

d. The front end of the L-shaped trigger is attached to the sear. When the trigger is pressed, it pivots around its pin and depresses the rear end of the sear. When the trigger is released, the sear spring returns all parts to their normal positions; this allows the sear to intercept the bolt and stop the firing cycle.

62. Accessories

A web sling, spare magazines, a magazine carrier, and a cleaning rod are usually available as accessories.

D. THE 9-MM MADSEN MODEL 50 SUBMACHINEGUN (DENMARK)

63. General

a. The 9-mm Madsen Model 50 submachinegun (fig 38), a remarkably simple weapon even for a submachinegun, uses pressed metal parts to the maximum. The "clamshell" method of opening the receiver readily exposes all of the gun's mechanism for user maintenance. A magazine loader and spare parts are stored in the pistol grip.

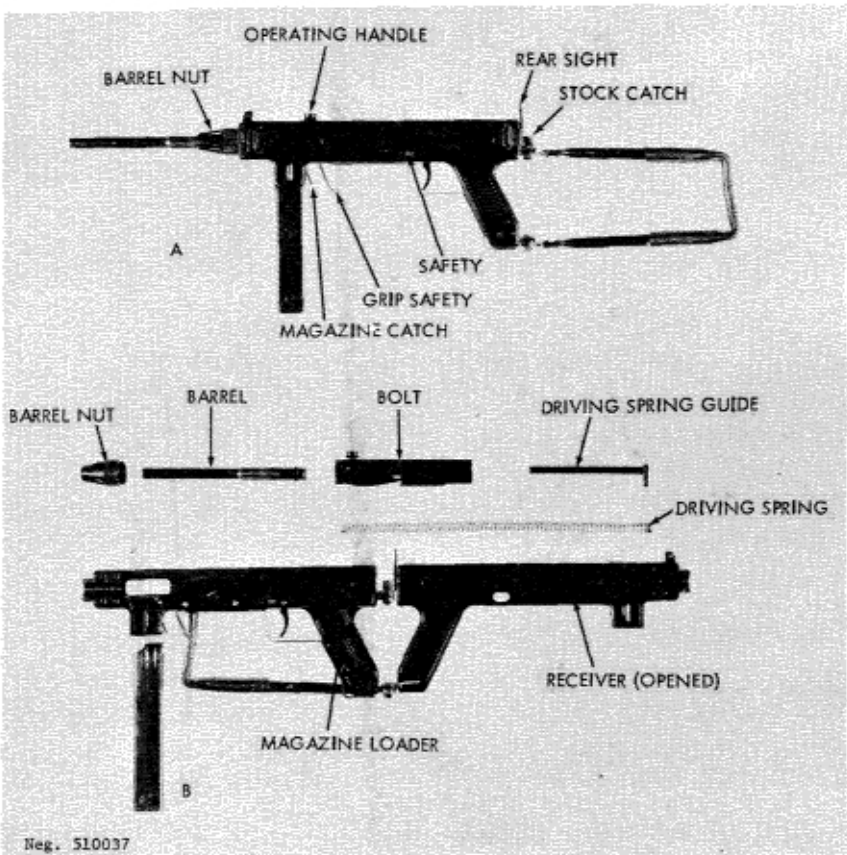

Figure 38. Danish Madsen Model 50 submachinegun.

b. Several variants of this submachinegun are in existence. An early model, the M1946 (fig 41), has a flat, flanged operating handle that extends across the top and down over the sides of the receiver. The more common M1950 (fig 38) uses a small circular knob for its operating handle. The M53 (fig 39) model has a curved magazine and a short cylindrical barrel nut that screws onto the barrel instead of onto the receiver as in the M46 and M50. The Mark II resembles the M53 but has a selector button located over the left grip plate; this model may also be fitted with



Figure 39. Madsen Model 1953 submachinegun.

a slotted barrel jacket over the full length of the barrel. In addition to the Danish guns, there is a 11.43-mm (.45-caliber) model, the INA Model 953 (fig 40) produced by Brazil. The operating handle on this model protrudes from the right side of the receiver.

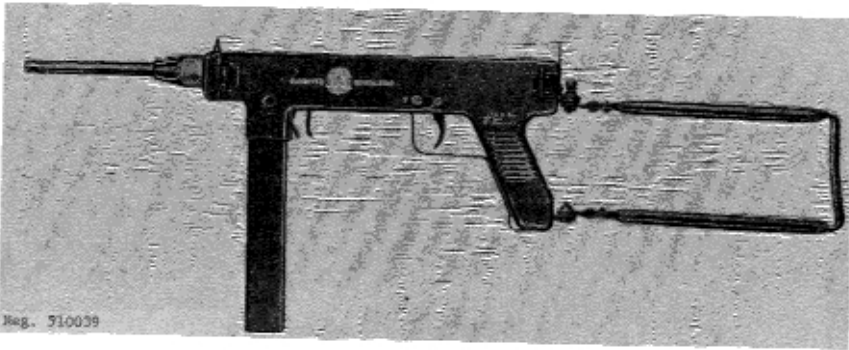

Figure 40. Brazilian INA 53 submachinegun.

c. The 9-mm Madsen submachinegun, used by the police and the armies of several European, Asian, and Latin American countries, is also sold commercially. These guns, stolen, captured, or purchased, are often found in use by guerrilla units.

d. The M46, M50, M53, and Mark II Madsens fire the 9x19-mm cartridge, the Brazilian INA 953 fires the US .45-caliber M1911 cartridge (sec V).

64. Technical Data

Technical data concerning the Madsen submachinegun are given in table III.

65. Operation

a. Open the receiver (para 66c) and remove the magazine loader from the pistol grip (fig 38). After loading the magazine, return the loader to its storage place and close the receiver.

b. Place the magazine loader over the top of a magazine; press the plunger down to depress the follower, and slide a cartridge-base end first-under the magazine feed lips. Release the plunger and slide the cartridge completely to the rear. Repeat this action until the magazine is filled (32 rounds). If the magazine loader is missing, load the magazine as prescribed in paragraph 59a.

c. Insert a loaded magazine into the magazine opening until the magazine catch snaps into place. Insure that the safety (fig 38) is in its forward position. Grasp the gun around the magazine housing and depress the grip safety (fig 38). Draw the operating handle (fig 38) fully to the rear and ease it forward until the bolt is caught by the sear. CAUTION: The gun is now ready to fire.

d. If the gun is not to be immediately fired, put it on safe by moving the safety to the rear. The stock can be folded or unfolded by depressing the stock catch (fig 38) and moving the stock to the desired position.

e. To fire the gun, move the safety forward, set the selector for the type of fire desired (Mark II only), and (using a normal sight picture) aim and press the grip safety and trigger. The

gun will fire until either the trigger is released (or semiautomatically, if so set on the Mark II) or the magazine is empty. The bolt will remain forward when the last round has been fired.

f. Remove the magazine by pressing the magazine catch (fig 38) and pulling the magazine out of the receiver.

g. Clear the gun by removing the magazine and pulling the bolt to the rear. Look into the ejection port to insure that no cartridges are present. Hold the operating handle, press the grip safety and trigger, and ease the operating handle forward. Replace the magazine.

66. Disassembly and Assembly

a. Clear the gun (para 65), but do not insert the magazine.

b. If the gun is a M1946 model, pull the operating handle straight up and out of the bolt. The handle is held by a spring-loaded detent.

c. Unscrew and remove the barrel nut (or jacket of a Mark III). Swing the receiver open (fig 38) and lift the barrel out. Pull the rear end of the driving spring guide (fig 38) forward out of its seat, and remove the guide and spring. Lift the bolt out of the receiver.

d. No further disassembly is necessary or desirable.

e. To reassemble the weapon, place the bolt back into the right receiver shell and insert the driving spring and its guide into the bolt. Force the rear end of the guide into its seat in the rear of

the receiver. Lay the barrel onto its seat in the front end of the receiver and insure that the flange on the barrel fits fully into the receiver groove. Swing the receiver closed and screw the barrel nut back into place. If the gun is an M46, press the operating handle down into the bolt until the detent snaps into place.

67. Functioning

The basic functioning of the blowback-operated Madsen submachinegun is similar to that of the M.A.T.-49 (para 61). The grip safety (fig 41) is a simple, spring-loaded catch that, unless manually depressed, will engage with the sear notch in the bolt and prevent the bolt from moving fully forward. When at safe, the safety blocks the sear and prevents it from depressing to release the bolt.

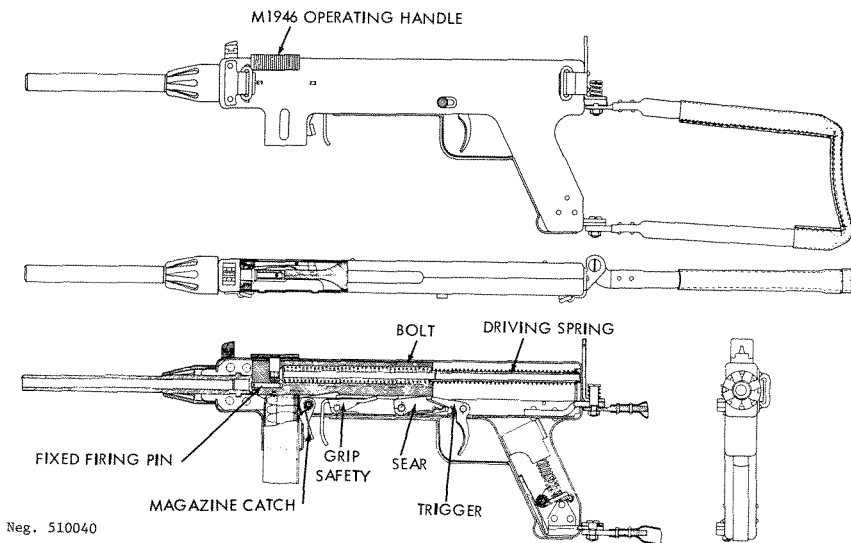

Neg. 510040

Figure 41. Madsen M1946 submachinegun, section.

68. Accessories

In addition to the normal accessories (such as a web sling, a spare magazine, and a magazine carrier), the Madsen submachineguns have a magazine loader stored in the grip. Each gun should also have a spare firing pin, an extractor, and a safety button stored in the grip.

E. THE 9-MM M45b SUBMACHINEGUN (SWEDEN)

69. General

a. The Swedish M45b submachinegun (fig 42) is the standard submachinegun of Sweden, where it was developed in 1945. The design is based on the British Mk 2 Sten submachinegun, considerably simplified. There are several variations in the M45 series guns; these variations usually involve the magazine and magazine housing. Original M45 guns used a large multi-row 50-round box magazine and had no magazine housing. The current M45b uses 32-round box magazines. Early models of the M45 have detachable magazine housings to allow the use of the 50-round magazine, while current production guns have permanently attached magazine housings (either welded or riveted).

b. In addition to its use by the Swedish Army, the M45 is sold commercially as the "Carl Gustaf" or "Swedish K" submachinegun. Copies are manufactured in Egypt as the "Port Said" submachinegun (fig 43).

70. Technical Data

Technical data concerning the M45 submachinegun are given in table III.

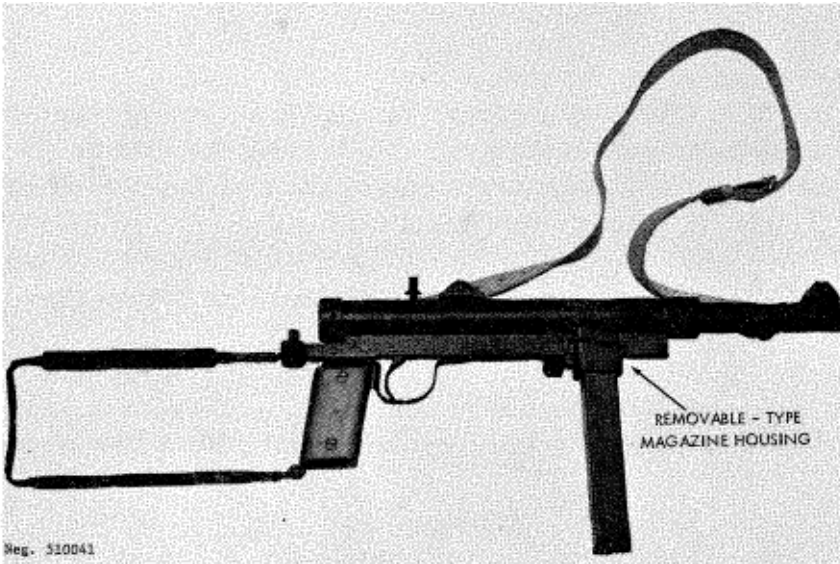

Figure 42. Swedish M45b submachinegun.

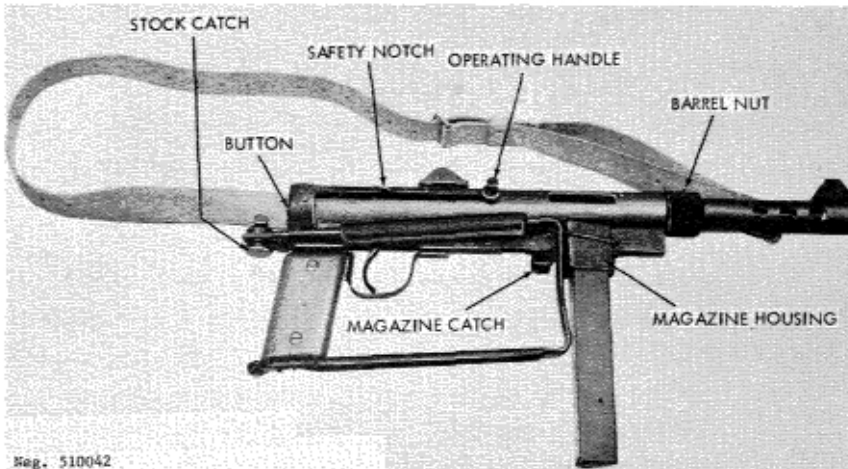

Figure 43. Egyptian Port Said submachinegun.

71. Operation

a. Load the magazine by placing a cartridge on the magazine follower between the feed lips; press the cartridge down until it rolls sideways under one of the feed lips. Repeat this action until 36 rounds have been loaded.

b. Insert the magazine into the magazine housing (fig 42) until the magazine catch retains the magazine.

c. Pull the stock away from the receiver to open the stock. Flip the rear sight to the desired range (100, 200, or 300 meters).

d. Pull the operating handle (fig 43) outward (if necessary); pull it to the rear, and then ease it forward until the bolt is caught by the sear. **CAUTION:** The gun is now ready to fire. Using a normal sight picture, aim and press the trigger. The gun will fire until the trigger is released or the magazine is empty. The bolt will remain forward after the last round has fired.

e. The gun can be made safe by pulling the operating handle rearward until it can be turned upward into the safety notch. Move the handle back to its normal position before attempting to fire.

f. Fold the stock by pressing the stock catch (fig 43) to the left and then forcibly press the stock to the right until it swings forward.

g. Clear the gun by removing the magazine, retracting the bolt, and insuring that no cartridges are present. Press the trigger and ease the bolt forward. Press the operating handle inward to lock the bolt; then insert the magazine.

72. Disassembly and Assembly

a. Clear the weapon (para 71g), but do not press the bolt handle in or insert the magazine.

b. Press in the button in the middle of the receiver cap (fig 43) and while holding the button inward, rotate the cap counterclockwise until it releases; ease the cap rearward and remove. Pull the driving spring out of the receiver.

c. Grasp the bolt handle and pull the bolt rearward, out of the receiver.

d. Press the small barrel nut lock at the lower rear of the barrel nut and unscrew the barrel nut. Pull the barrel jacket and barrel nut forward, off the receiver. Pull the barrel forward, out of the receiver.

e. No further disassembly is required or desirable.

f. To reassemble, insert the barrel into the receiver, twisting the barrel until it seats and cannot rotate. Place the barrel jacket over the barrel, insuring that the jacket slot mates with the key protruding from the top front of the receiver. Finger-tighten the barrel nut.

g. Slide the bolt into the receiver, large end first and bolt handle aligned with the long slot. Point the muzzle down and press the trigger; bolt will slide forward. Insert the driving spring into the receiver so that it seats onto the bolt. Place the receiver cap over the spring. Press the cap forward, aligning hook on the cap with the left side of the plate on top of the receiver. When the hook is in front of the plate, rotate the cap to the right until it locks into place. Press the bolt handle inward and insert the magazine.

73. Functioning

a. The M45 is blowback operated (refer to para 47a).

b. The firing cycle starts with the bolt cocked to the rear, caught by the sear, compressing the driving spring (fig 44). Pressure on the trigger causes it to rotate, and a forward lug on the trigger bears against the rear of the sear to force the sear down to release the bolt. The driving spring forces the bolt forward. As it moves, the feed rib drives a cartridge out of the magazine and into the barrel chamber. As the cartridge seats in the barrel, the fixed firing pin strikes the primer and fires the cartridge.

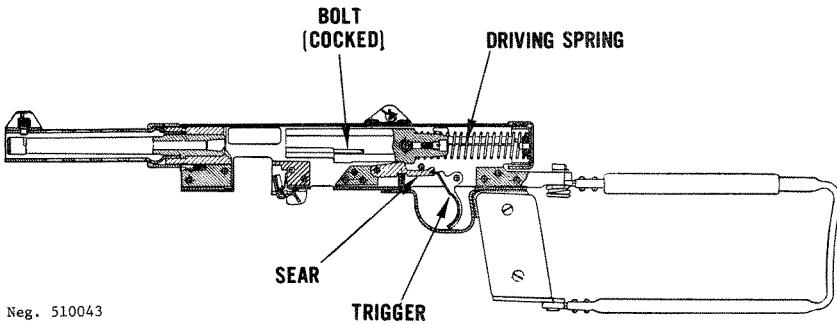

Neg. 510043

Figure 44. M45b section.

c. The rearward thrust of the fired cartridge blows the bolt rearward, compressing the driving spring. The extractor holds the cartridge against the bolt face until the fixed ejector expels the case.

d. Release of the trigger allows the sear to rotate upward to intercept the bolt, stopping the firing cycle.

e. The bolt handle safety, when pressed in, mechanically engages a hole in the left wall of the receiver to lock the bolt forward. When the handle is turned up into the safety slot, the

mechanical interference between the handle and receiver prevents the bolt from being drawn forward.

74. Accessories

The usual submachinegun accessories (spare magazines, a sling, and a cleaning rod) are supplied with these guns.

F. THE 9-MM BERETTA M38, M38/49, M4, AND M5 SUBMACHINEGUNS (ITALY)

75. General

a. The Italian Beretta M38 series submachineguns are excellent, well-constructed weapons. The basic design, as indicated by the model designation, dates back to 1938. There have been many changes and modifications to the basic M38 gun. The current Beretta Model 38/49 or its commercial versions, the Beretta M4 and M5, represent the continual refinements of the original design.

b. The Beretta M38 series submachineguns were used by both the Italian and German armies during World War II, and numerous captured weapons were used after World War II by many European and African nations. The current Model 38/49, initially produced in 1949, has been purchased by Costa Rica, Egypt, Indonesia, Dominican Republic, Thailand, West Germany, Tunisia, and Yeman. In West Germany, the Beretta 38/49 (known as the MP1) is used by border guards.

c. The original Beretta M38 and M38A (fig 45) had perforated barrel jackets with built-in compensators; however, the original 38 had a single-baffle muzzle brake and a bayonet lug, and the 38A had a four-slot muzzle brake and no bayonet lug. M38A's were last produced in 1947 for the Argentine Government. The



Figure 45. Italian Beretta M38A submachinegun.

M38A was simplified during World War II, primarily by removing the barrel jacket and cutting compensator slots directly into the barrel. The resultant weapon, the Model 38/42 (fig 46), is the basis for the later M38/49, M4, and M5 weapons. The M38/42, identified from later models by its fluted barrel, is still widely used in Europe and Africa.



Figure 46. Beretta M38/42 submachinegun.

d. A simplified version of the M38/42, the M38/44, was produced immediately after World War II for Syria, Pakistan, Iraq, and Costa Rica. This gun, the immediate predecessor of the M38/49, has a simplified bolt and receiver cap but does not have the cross bolt safety of the M38/49.

e. The current gun is the Beretta Model 38/49 (fig 47), also known as the Beretta Model 4. This gun can be easily recognized by its push-through safety. A variation, the Beretta Model 5, is identical except that the push-through safety has been replaced with a large grip safety bar (fig 47).

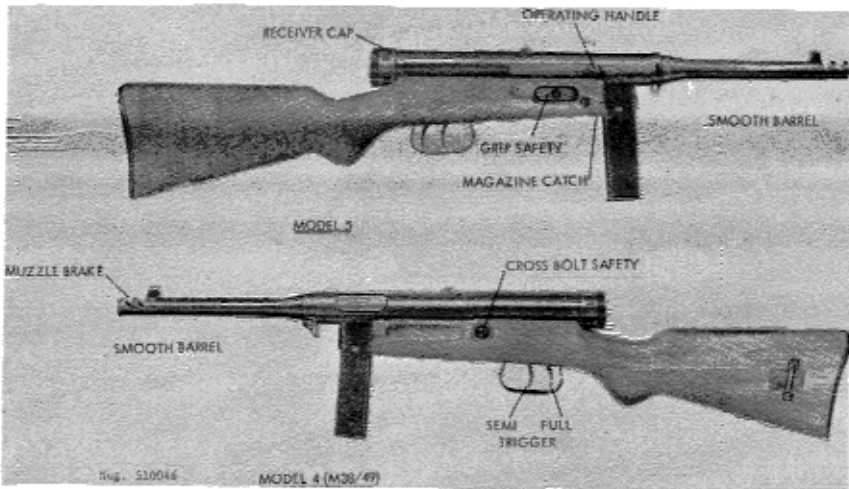

Figure 47. Beretta Model 4 and Model 5 submachineguns.

f. The Beretta 38 series submachineguns are selective-fire weapons; the two triggers govern the type of fire. The guns are blowback-operated and fed from 10-, 20-, or 40-round box magazines. Prime recognition points are the double triggers and the slots cut across the muzzle end of the barrel (fig 45, 46, and 47). All the Beretta M38 series weapons fire the 9x19-mm cartridge (sec V).

76. Technical Data

Technical data concerning the Beretta M38/49 submachineguns will be found in table III.

77. Operation

a. Load the magazine as described in paragraph 71a. If a magazine filler and clipped cartridges are available, place the filler over the mouth of the magazine, insert the clip into the guides in the filler, and, with thumb pressure, force the cartridges off the clip into the magazine. Repeat until the magazine is full, then remove the filler.

b. Insert the loaded magazine into the magazine guide until the magazine catch snaps into place. Push the safety catch to the left or, for a Model 5, depress the grip safety bar (fig 47). On the earlier M38, M38A, M38/42, and M38/44, push forward the safety (on the left side of the receiver) (fig 45). Pull the operating handle fully rearward to cock the weapon, then return it forward. **CAUTION:** The gun is now ready to fire.

c. If the weapon is not to be fired immediately: On the M38, M38A, M38/42, and M38/44, move the safety (fig 45) rearward; on the M38/49 or M4, push the safety (fig 47) to the right; or on the M5, release the grip safety bar. To fire, move the safety back to fire position (or, on the M5 squeeze the grip safety bar), aim, and press the trigger. If the front trigger (fig 45) is pressed, only one shot will be fired. This trigger must be released and repressed to fire successive shots. If the rear trigger (fig 45) is pressed, the weapon will continue to fire until the magazine is empty. When the last round is fired, the bolt will close on an empty chamber. Press the magazine catch (fig 47) and pull the magazine out of the gun.

d. To clear the Berettas, remove the magazine, then cock the bolt as described in paragraph c above. Look through the ejection port to insure that no cartridges are present, pull the operating handle rearward, and, while holding the handle, press the trigger (on the M5, first depressing the grip safety bar), and

ease the operating handle forward. Move the safety to the safe position and insert the magazine.

78. Disassembly and Assembly

a. Clear the gun (para 77), but do not insert the magazine or apply the safety. Rotate the receiver cap (fig 47 and 48) one-quarter turn to the left and ease it back. Remove the receiver cap and pull the driving spring and bolt out of the receiver. It may be necessary to elevate the muzzle and press the trigger (first depressing the grip safety bar on the M5) to allow the bolt to slide rearward out of the receiver. No further disassembly is required or desirable.

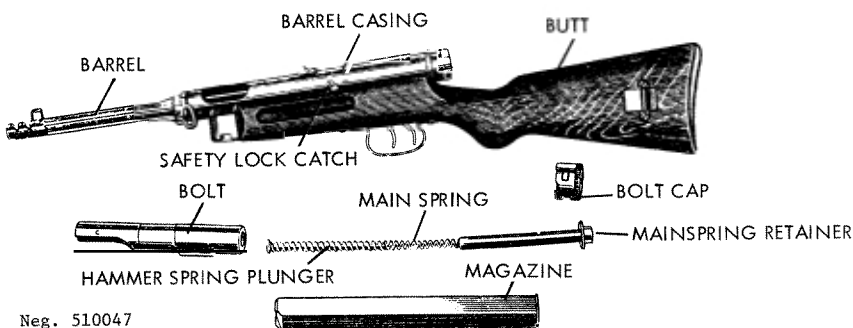

Neg. 51.0047

Figure 48. Beretta submachinegun, disassembled.

b. To reassemble, slide the driving spring over the rear end of the bolt, then insert the bolt into the receiver. The lug on the bolt must align with the slot in the bottom of the receiver. Point the muzzle down and press the trigger (on the M5, first depressing the grip safety bar) to allow the bolt to slide forward. Place the receiver cap over the end of the driving spring and press forward until the cap fits onto the receiver. Rotate the cap to the right until the indicator arrows align. Insert the magazine. Note: When reassembling the M5, keep the grip safety bar depressed.

79. Functioning

a. The Beretta M38 series submachineguns are blowback-operated, without positive locking between the bolt and receiver. The weight and inertia of the bolt hold the fired cartridge case in place until the bullet leaves the muzzle and propellant gas pressure subsides. The rearward thrust of the fired cartridge, however, is sufficient to overcome the weight and inertia and to force the bolt rearward against its driving spring.

b. When a loaded magazine is in place and the bolt is cocked, pressure on the trigger rotates the sear out of engagement with the bolt. The compressed driving spring drives the bolt forward, and the feed rib on the bolt drives the top cartridge from the magazine into the barrel. As the bolt continues forward, the extractor snaps over the rim of the cartridge, and the firing pin strikes the primer to fire the cartridge. Acting like a piston, the fired cartridge drives the bolt rearward and compresses the driving spring. The extractor holds the cartridge case in place in the bolt face until the case strikes the fixed ejector in the rear of the magazine housing. The case is then expelled through the ejection port. This cycle continues until the trigger is released or the magazine is emptied.

c. When the front (semiautomatic) trigger is pressed, the trigger rotates on its pin and a long forward extension swings downward. This extension contacts a pawl in the rear of the sear to rotate the sear about its pin to release the bolt. As the trigger and sear continue to rotate, the extension slips off the sear pawl, and the sear spring returns the sear upward where it can intercept the bolt. To fire another shot, the trigger must be released; as it is, the extension forces the pawl inward until the extension passes the pawl. The pawl then springs out under the trigger extension.

d. When the rear trigger is pressed, its long extension depresses the sear as before; but, because of the length of the

extension, the sear is held depressed and the gun fires automatically.

e. On all guns, when the safety is applied, a block moves under the sear and prevents it from being depressed.

80. Accessories

The only accessories available are spare magazines, magazine loader, sling (leather or fabric), and sectional cleaning rod.

G. THE 9-MM BERETTA MODEL 12 SUBMACHINEGUN (ITALY)

81. General

a. The 9-mm Beretta M12 submachinegun (fig 49) is a modern-design gun produced in Italy. It is a standard weapon in the Italian Army and is offered for commercial sale to other countries. A copy of this gun is also produced in Indonesia.

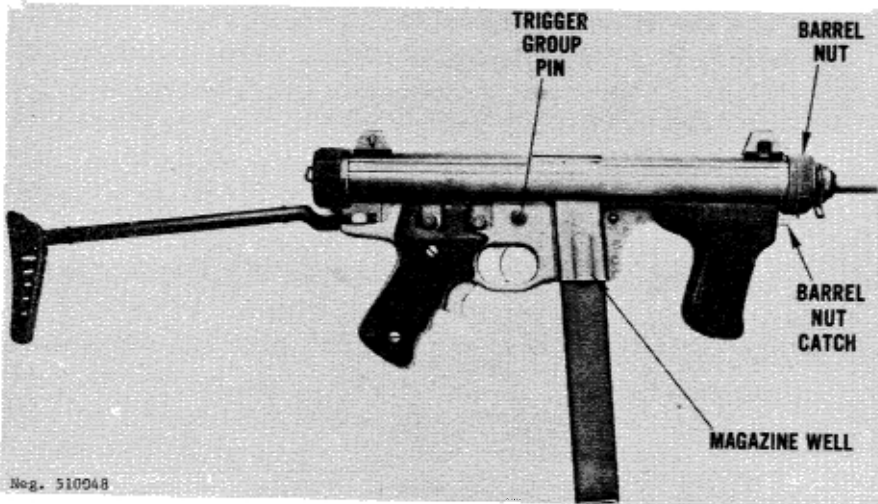

Figure 49. Italian Beretta Model 12 submachinegun (early model).

b. The M12 is a blowback-operated, selective-fire weapon fed from 20- or 40-round capacity box magazines. The bolt of this gun extends forward over most of the barrel, thus allowing use of a long barrel in a fairly short and compact weapon. The Beretta M12 is easily recognized by its double-hand grips, large wedge-shaped operating handle, and grip safety in front of the rear grip (fig 50). The M12 is usually found with a folding metal stock, but a conventional, fixed wood stock is also available.

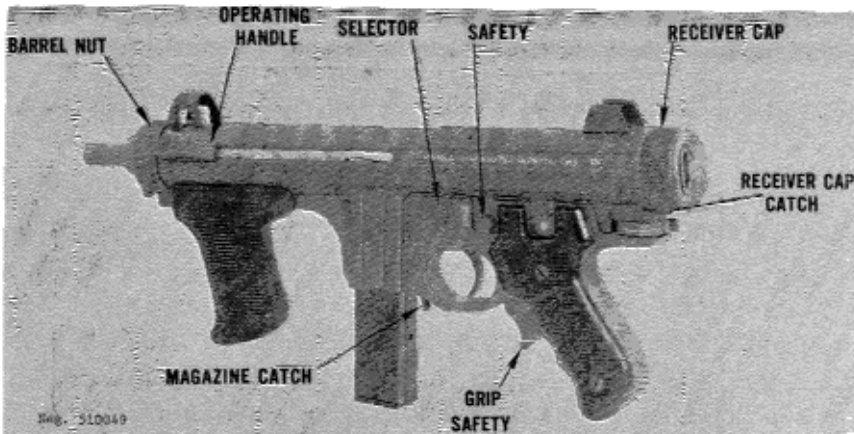

Figure 50. Beretta Model 12 submachinegun, stock folded, (late model).

c. The Beretta M12 submachinegun fires 9x19-mm ammunition (sec V).

82. Technical Data

Technical data concerning the Beretta M12 submachinegun will be found in table III.

83. Operation

a. Load the magazine by placing a cartridge on the magazine follower or top cartridge and pressing the cartridge down

until it rolls sideways under a feed lip. Repeat until the magazine is full.

b. If the weapon is equipped with a folding stock, open the stock by vigorously swinging it rearward. Reverse to close.

c. Insert a loaded magazine into the magazine well (fig 49) until the magazine catch snaps into place. Press the safety button (fig 50) to the left, squeeze the grip safety, and pull the operating handle (fig 50) fully rearward, then ease it forward until it is caught by the sear. CAUTION: The weapon is now ready to fire.

d. If the weapon is not to be fired immediately, place it on safe by pressing the safety button in the top center of the rear grip (fig 50) to the right. Upon release of the rear grip, the grip safety (fig 50) will automatically move to the safe position.

e. To fire, select the mode of fire by pressing the selector (above the trigger) (fig 50) to the right for semiautomatic fire and to the left for automatic fire. Press the safety button (fig 50) to the right, and squeeze the grip safety (fig 50). Aim (using a normal sight picture) and press the trigger. If the selector has been set for semiautomatic, the gun will fire one shot, after which the trigger must be released and repressed to fire a second shot. If the selector has been set for automatic, the gun will fire continually until the trigger is released or the magazine is empty. The bolt will remain open between shots but will close on an empty chamber when the last round in the magazine is fired.

f. To clear the gun, press the magazine catch (fig 50) and withdraw the magazine. If necessary, pull the operating handle fully to the rear and ease it forward until it is caught. Inspect through the ejection port to insure that no cartridges are present. Hold the operating handle, squeeze the grip safety and trigger (fig 50), and ease the operating handle forward. Push the safety button to the left (safe) and insert the magazine.

84. Disassembly and Assembly

a. Clear the gun, but do not set on safe or insert the magazine.

b. Depress the barrel nut catch (fig 49) and unscrew the barrel nut. Pull the barrel nut, barrel, and bolt forward out of the receiver. Twist the barrel nut until it aligns with its grooves in the barrel and can be removed. Pull the barrel upward, then rearward, to remove it from the bolt.

c. Depress the receiver cap catch (fig 51) and unscrew the receiver cap. Remove the cap and driving spring.

d. If desired, push out the trigger-group pin retainer and then push out the trigger-group pin (fig 51). Pull the trigger group down and off the receiver.

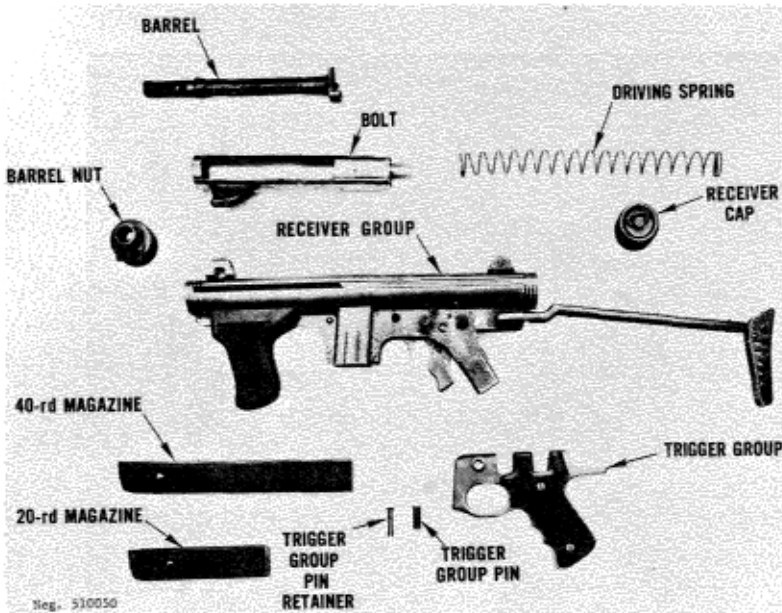

Figure 51. Beretta Model 12 disassembled.

e. Further disassembly is neither required nor desirable.

f. To reassemble, if the trigger group has been removed, engage its rear top with the receiver and then swing the front end up into place. Install the trigger-group pin and its retainer.

g. Slide the driving spring into the receiver and, after depressing the receiver cap catch, screw the cap back onto the receiver.

h. Slide the muzzle end of the barrel through the ring on the front of the bolt, then place the flange on the rear of the barrel in front of the bolt face. Slip the barrel nut onto the barrel, align the ribs on the nut with the grooves on the outside of the barrel, and fully seat the nut against the solid shoulder of the barrel.

i. Insert the barrel and bolt assembly into the front of the receiver, depress the barrel nut catch (fig 51), and screw the barrel nut into the receiver. Insert the magazine.

85. Functioning

a. The Beretta M12 submachinegun is blowback-operated; refer to paragraphs 79a and b for basic bolt functioning.

b. When the trigger is pressed, it pivots around its pin, and the spring-loaded disconnecter, pivoted to the rear end of the trigger, rises until it contacts the front of the sear. Continued trigger pressure will cause the sear to rotate around its pin and, as the rear end of the sear depresses, it releases the bolt. Further action of the disconnecter depends on the position of the selector. The selector is a cylindrical steel shaft with a groove turned in its middle. When the selector is in the automatic fire position, this groove is aligned with the disconnecter. In this position the

selector has no influence on the disconnecter; the disconnecter will continue to hold the sear up, and the sear nose will not intercept the bolt. When the disconnecter is moved to the semiautomatic position, the solid section of its shaft moves into position behind the disconnecter. Pressure on the trigger will again cause the disconnecter to rise which, in turn, raises the front end of the sear. As trigger pressure continues, the lower end of the disconnecter contacts the selector shaft and the shaft, bearing on the disconnecter, forces the disconnecter to pivot forward on its pin. The forward movement of the disconnecter moves it out from under the seat. The sear, under pressure from its spring, rotates around its pin so that it intercepts the bolt after it recoils. To fire another shot, the trigger must be released; this lowers the disconnecter so that it springs rearward under the sear. When this occurs, trigger pressure will cause another shot to be fired.

c. The grip safety normally presents a solid block to the front of the sear; this block prevents the sear from moving. The grip safety also forces a vertical shaft upward to block the bolt. When the grip safety is squeezed, it pivots on its pin to unblock the sear and pull the vertical shaft away from the bolt. The weapon can now be cocked or fired.

d. The manual safety, when applied, restrains movement of the grip safety. The grip safety, as explained in paragraph c, prevents movement of the sear or bolt.

86. Accessories

A canvas or leather sling, spare 20- or 40-round magazines, and magazine carriers are the only accessories available for the Beretta Model 12 submachinegun.

H. THE 9-MM STEYR MODEL 69 SUBMACHINEGUN (MPISTEYR 69) (AUSTRIA)

87. General

a. The Austrian 9-mm Steyr submachinegun is a product of the world-famous Steyr Daimler Puch factory, a firm that has produced small arms for over 100 years. The Steyr submachinegun was recently adopted by the Austrian Federal Armed Forces under the designation "Maschinenpistole Steyr 69" or MPiSteyr 69." The Steyr submachinegun is also offered for sale to foreign purchasers. The Steyr submachinegun is blowback-operated, selective-fire, and fed from 25- or 32-round capacity box magazines. The gun is equipped with a sliding wire stock. The sighting equipment comprises a conventional "L"-flip aperture rear sight and zeroable-protected post front sight. Pads for mounting a "Singlepoint" sight are standard.

b. The Steyr submachinegun (fig 52) closely resembles the well-known UZI submachinegun (subsec B) both in configuration and mechanical operation. The design of UZI, in turn, obviously was influenced by the Czechoslovak Vz 23 submachinegun.

c. The Steyr Model 69 submachinegun fires 9x19-mm ammunition (sec V).

88. Technical Data

Technical data concerning the Steyr Model 69 submachinegun will be found in table III.

89. Operation

a. Load the 25- and 32-round magazines the same way. If a magazine filler is available, place it over the magazine mouth so

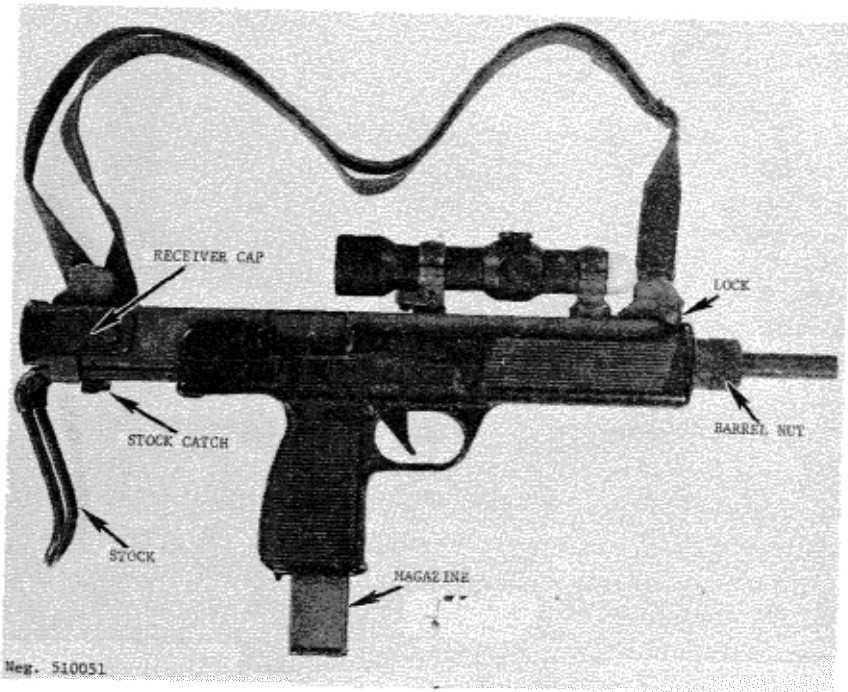
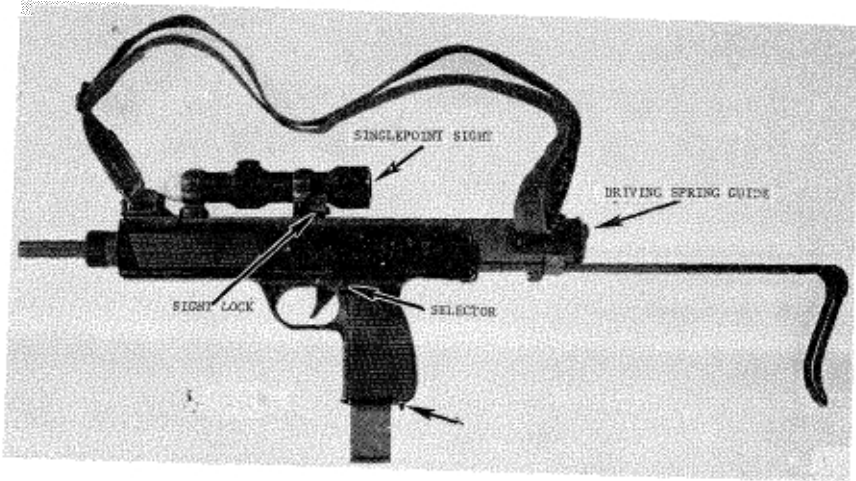

Figure 52. Austrian Steyr MPi Steyr 69 submachinegun.

that the opening in the filler is on the same side of the magazine as the indicator hole. Place the magazine on a firm surface, insert a cartridge into the opening of the filler, press the filler down against the magazine, and release it. Repeat until the magazine is full. When the magazine is full, a cartridge will show in the indicator hole. If no magazine filler is available, place a cartridge on the follower, bullet toward the angled cut on the magazine mouth, and press the round down until it seats under one of the feed lips. Repeat until the magazine is full.

b. Insert a loaded magazine into the opening in the bottom of the pistol grip and seat it until the magazine catch snaps into place to retain the magazine. Press the selector (fig 52) to the right until the white groove around the selector is visible. Squeeze the stock catches (fig 52) together and move the stock to either its extended or closed position as desired. The best results will be obtained by extending the stock and bracing it against the shoulder during firing.

c. If the metallic sights are used, flip the rear aperture to the desired range (100 or 200 meters). Use a normal sight picture for aiming.

d. If the Singlepoint sight is used, attach the sight to the weapon by holding it at a 45-degree angle to the right of the receiver and mating the front mount ring with the front square pad. Swing the rear end of the sight to the left until the sight latch snaps into engagement with the rear mounting pad. To remove the Singlepoint sight, pull the sight latch rearward and, while holding the latch, swing the rear end of the sight to the right as far as possible. Lift the sight to remove it. Aiming instructions when using the Singlepoint sight are found in paragraph 91.

e. Cock the Steyr submachinegun by grasping the sling behind its front leather reinforcement, pulling the sling directly

out to the side (disengaging the cocking slide catch from the front sight base), and pulling the sling and attached cocking slide to the rear. Release the sling; it and the cocking slide will return forward. CAUTION: The weapon is now cocked and ready to fire.

f. To fire: Move the selector off safe by pressing it to the left. When the selector is in midposition, with the red groove around the selector just visible, pressing the trigger will fire one shot. To fire successive shots, the trigger must be released and repressed for each shot. When the selector is pressed fully to the left, light pressure on the trigger will fire one shot semiautomatically; but heavy pressure (moving the trigger fully to the rear) will cause the weapon to fire automatically. The bolt will remain open between bursts and will close on an empty chamber when the last round in the magazine is fired.

g. Remove the empty magazine by pressing the magazine catch (fig 52) toward the magazine and withdrawing the magazine.

h. Clear the Steyr submachinegun by first pressing the selector fully to the right so that the white groove around the selector is visible. Press the magazine catch and remove the magazine. Grasp the front of the sling behind its leather reinforcement, pull it out to the side, then straight back. Release the sling. Inspect through the ejection port to insure that no cartridges are present. Press the selector to the left, pull the sling rearward, and press the trigger. Ease the bolt forward, repress the selector fully to the right (safe), and insert the magazine.

90. Disassembly and Assembly

a. Clear the gun (para 89), but do not set the selector back on safe or insert the magazine. Remove the Singlepoint sight if present (para 89).

b. Press in the rounded end of the driving spring guide where it protrudes through the receiver cap (fig 52). Swing the receiver cap upward to open the rear of the receiver. Grasp the sides of the buffer pad (fig 53) and withdraw the bolt, buffer, and driving-spring unit.

c. Press back the barrel nut lock (fig 52) and, while holding it back, unscrew the barrel nut. Pull the barrel forward out of the receiver.

d. Press the stock catches (fig 52) together and pull the stock clear off the weapon.

e. Remove the trigger frame assembly (fig 53) by gently tapping it forward on the receiver until the rear of the trigger frame can be pulled away from the receiver and separated. **DO NOT USE EXCESSIVE FORCE.** The trigger frame fits tightly on the receiver, but it can be removed with minimum force.

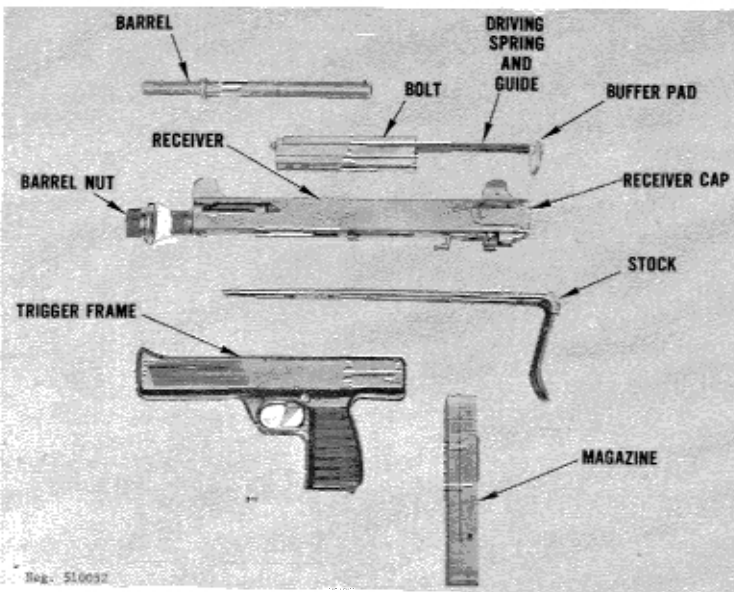

Figure 53. MPi Steyr 69 disassembled.

f. To reassemble, first slip the front receiver insert through the hole in the trigger frame. Tap the receiver forward in the trigger frame until the threads appear. Insert the barrel, insuring that the barrel shoulder seats fully into the front receiver insert. Screw the barrel nut onto the front receiver insert and hand tighten until the front edge of the receiver is snug against the trigger frame.

g. Insert the bolt unit into the receiver, driving spring to the left top. Point the muzzle down and press the trigger; the bolt will slide home. Press in the driving spring guide head (fig 53) and swing the receiver cap over the opening at the rear of the receiver. Insure that the driving spring guide head seats in the hole in the receiver cap.

h. Start the stock into its guide under the rear of the receiver, press the stock catches (fig 52) together, and seat the stock. Attach the Singlepoint sight (para 89) and insert the magazine.

91. Sight Adjustment

a. The aperture rear sight cannot be adjusted beyond setting it at one of its two range settings (100 or 200 meters). All zero adjustments are made at the front sight. (See paragraph d for description of the front sight.)

b. The front sight is adjusted for both vertical and horizontal zero by turning the sight in the base. The sight is threaded, and rotary motion will screw the sight into or out of the base to change the height of the front sight post. The post is formed off center, and rotary motion also will cause a relative side-to-side motion of the blade.

c. A special wrench is required for zeroing. The outer sleeve is used to loosen or tighten the sight lock nut. The inner sleeve is used to turn the front sight when the lock nut is loose. To use the wrench, place it over the front sight, insuring that the lugs on the outer sleeve mate with the slots in the lock nut and that the slot on the inner sleeve mates with the front sight. Turn the outer sleeve about a half turn, counterclockwise, to loosen the lock nut. Turn the inner sleeve as necessary to align the line of sight with the bullet impact. Hold the inner sleeve stationary and turn the outer sleeve clockwise until the lock nut is tight. Fire at least three well-aimed semiautomatic shots and readjust as necessary. Turning the front sight clockwise lowers the impact of the bullet relative to the line of sight and, as the front post moves to the right, the point of impact moves left.

d. The Singlepoint sight can also be zeroed. Attach sight as directed in paragraph 89d. Remove the cover from the elevation and windage screws and fire several semiautomatic shots at 50 meters range. If the bullets hit above or below the target, use a coin to turn the adjustment screw on the top (elevation) drum. Refire and readjust until satisfactory hits are achieved. Side-to-side zero is accomplished in two stages. Set the windage screw on the side (windage) drum to zero and fire a few shots semiautomatically. Coarse adjustments are made by loosening the opposing screws on the rear mount ring just ahead of the thumbpiece. Tighten one of the screws to move the rear sight (tightening the left screw moves the bullet strike to the right), then tighten the other screw to lock the adjustment. Refire and readjust as needed. Final fine adjustment is made by turning the screw in the windage drum with a coin. The direction of bullet strike is marked on the drum. Both eyes must be open when using the Singlepoint sight. One eye looks into the sight, the other at the target.

92. Functioning

a. The Steyr submachinegun is blowback-operated. When the gun is cocked and a loaded magazine is in place, pressure on the trigger causes the sear to release the bolt. The bolt, under pressure of the compressed driving spring, goes forward. The feed rib (fig 54) on the bottom of the bolt strikes the top cartridge in the magazine and drives the cartridge up the feed ramp and into the chamber. The extractor snaps into the extractor groove in the cartridge case and the fixed pin (fig 54) strikes the primer to fire the cartridge.

b. The cartridge, upon firing, generates gas to drive the bullet through the barrel; at the same time, the gas drives the cartridge case rearward with great force. The case is held, however, by the slight remaining forward movement of the heavy bolt. By the time the rearward thrust of the cartridge case overcomes the bolt's inertia and drives it rearward, the bullet has left the muzzle, the gas pressure has subsided, and only low residual pressure remains. The bolt has had sufficient momentum to continue rearward and compress the driving spring. The extractor holds the cartridge to the bolt face until the case strikes the fixed ejector. The ejector pivots the cartridge case around the extractor and expels the case through the ejection port. The bolt continues its rearward movement until it strikes the buffer (fig 54) and stops. The driving spring then forces the bolt forward again. The magazine spring has forced a fresh cartridge up in the magazine feed lips, and the bolt is ready to commence another firing cycle, as activated by the trigger mechanism.

c. The trigger mechanism is simple in construction but sophisticated in functioning. Figure 54 is a sectional view of the trigger mechanism. The sear and the trigger have free fore and aft movement, but the latter is spring-loaded to the rear.

Figure 54. MPi Steyr 69 section.

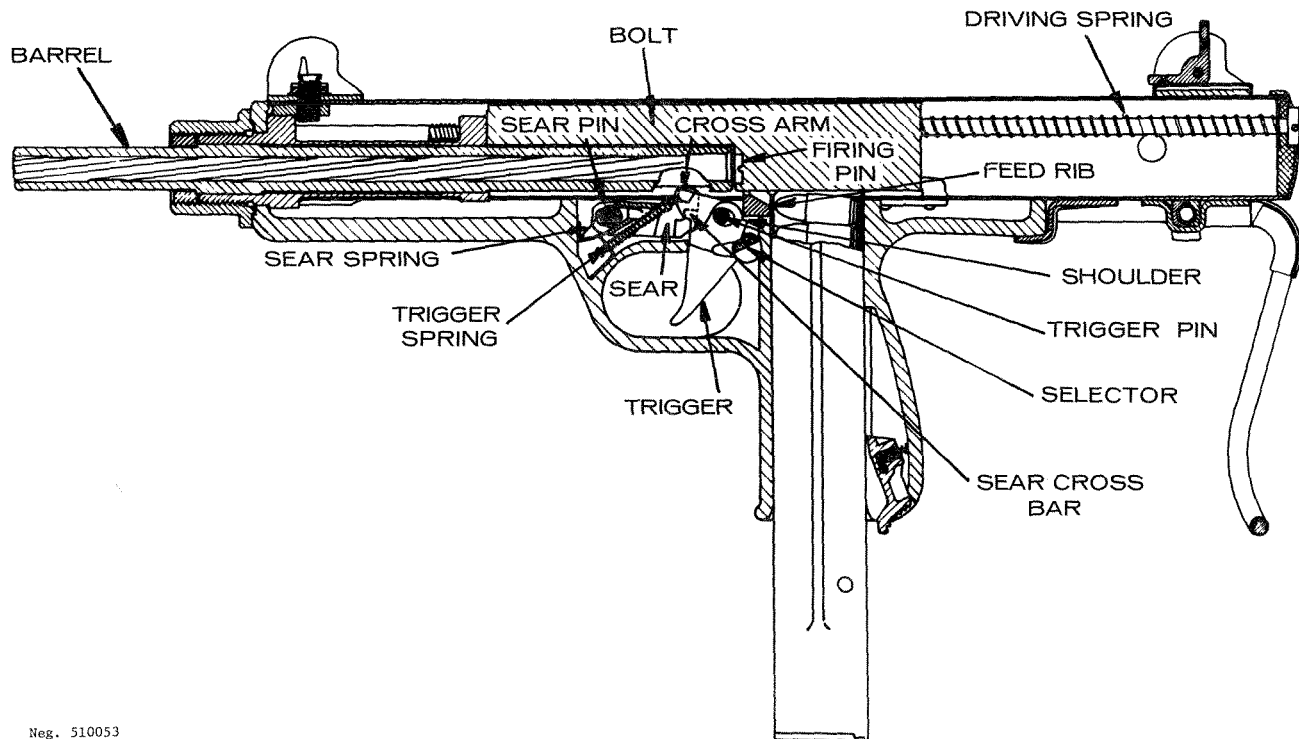

d. When the weapon is cocked, the sear nose engages the sear notch of the bolt. The pressure of the driving spring, transmitted through the bolt, moves the sear to its foremost position. When the sear is so positioned, the forward crossarm of the trigger is positioned over the rear crossbar of the sear. Pressure on the trigger will rotate it about its pin, and its forward arm will rotate the sear about its pin. When this occurs, the bolt is released, and a cartridge is fired.

e. If the selector is in its mid or semiautomatic position, the rearward movement of the trigger is limited, and the sear depresses just enough to release the bolt. The bolt, upon completion of its forward travel, impacts upon the receiver and imparts a forward motion to the gun. The heavy sear, however, tends to remain stationary as the gun moves forward. As the trigger moves with the gun, the crossarm of the trigger rides forward, off the crossbar of the stationary sear. The sear then rises, under force of its spring, to reengage the bolt. As engagement occurs, the sear is again driven forward by the driving spring, but the sear crossbar strikes the crossarm of the still-depressed trigger, and all motion ceases. To fire another shot, the trigger must be released; this allows the crossarm to rise above the crossbar and release the sear. The driving spring then moves the sear fully forward so that its crossbar is under the crossarm of the trigger. Pressure on the trigger will not repeat the semiautomatic cycle.

f. When the trigger is pressed fully to the left to its full semiautomatic position, the selector no longer limits the distance that the trigger can be pressed. However, the front edge of the feed rib intercepts a shoulder on the rear of the trigger, limiting trigger movement to that required for semiautomatic fire. When the trigger is pressed, the initial firing cycle is as described in paragraph e above, except that the feed rib now limits trigger

travel. If light pressure is applied, the gun will go through a semiautomatic cycle and fire one shot. If heavy pressure is applied, a semiautomatic cycle will commence, but upon post-firing recoil (or when the bolt strikes the buffer), the trigger moves forward slightly against the force of its spring. As the trigger moves, its rear shoulder moves out of engagement with feed rib, and the trigger moves fully rearward. As it does so, the trigger crossarm bears on the sear just ahead of the crossbar, and because of the increased distance the trigger rotates, the crossarm holds the sear fully depressed. Because the trigger crossarm bears on the sear proper and not on the higher sear crossbar, the sear remains depressed, and the weapon fires automatically. When the trigger is released, the sear rises, under pressure of the sear spring, and intercepts the bolt to stop the firing. The trigger also moves rearward so that its shoulder will mate with the feed rib.

g. When the selector is pressed fully to the right, it interposes a solid shoulder behind the trigger and prevents trigger movement.

93. Accessories

a. Few accessories are available for the Steyr submachinegun. The sling, usually considered an accessory to most small arms, is an essential weapon component on the Steyr because it is used to cock the weapon and cannot be removed without damage to the sling.

b. Twenty-five and 32-round capacity magazines and a magazine filler are available. Two special tools are also available. One is a spanner used to loosen the barrel nut; the other, a tubular wrench, is used to adjust the front sight.

I. THE 9-MM WALTHER MP-K AND MP-L SUBMACHINEGUNS (WEST GERMANY)

94. General

a. The 9-mm Walther MP-K and MP-L submachineguns (fig 55 and 56) are not standard in any army, but they are produced in large quantities and are found in use by paramilitary and naval forces. The MP-K (Maschinen-Pistole Kurz-submachinegun, short) and MP-L (Lang-Long) are identical except that the barrel and front receiver of the MP-L are longer than those of the MP-K. The guns are easily recognized by their prominent rear sight guards, the bulging appearance of the top receiver, and the oddly shaped folding metal butt stock.

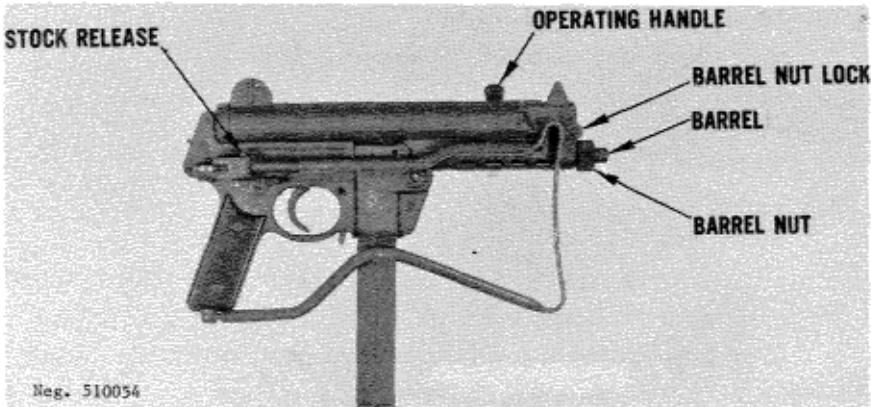

Figure 55. West German Walther MP-K submachinegun.

b. The Walther MP-K and MP-L submachineguns are simple, blowback-operated, open-bolt firing, selective-fire weapons, fed from detachable 32-round capacity box magazines.

95. Technical Data

Technical data concerning the MP-K and MP-L submachineguns are given in table III.

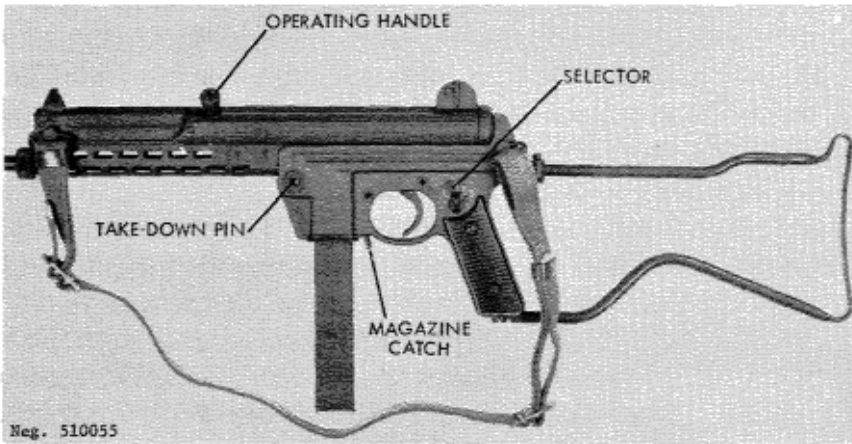

Figure 56. West German Walther MP-L submachinegun.

96. Operation

a. Load the magazine as described in paragraph 89a. Rotate the selector (fig 56) to safe (S). Insert the loaded magazine into the magazine well until the magazine catch snaps into place and retains the magazine.

b. If the stock is folded forward, grasp it and vigorously pull it to the side, away from the receiver. Continue moving it rearward until it locks into its open position. To fold the stock forward, press the stock release (fig 55) and swing the stock forward. Best results are obtained, when firing, by using the extended stock; however, for close-range firing, the vertical part of the fold stock can be used as a foregrip to aid in controlling the pointing of the gun.

c. Rotate the selector (fig 56) rearward to its "S" or safe position. Pull the operating handle (fig 56) fully rearward and release it. The gun incorporates an automatic safety device to intercept the bolt if it is drawn back far enough to pick up a cartridge from the magazine, but not far enough to catch on the

sear. Insure that the operating handle is drawn fully to the rear. CAUTION: Except for being on safe, the gun is now ready to fire. Prior to firing, rotate the selector forward "D" (automatic fire) or "E" (semiautomatic fire).

d. The sights on the Walther MP-K or MP-L are set for 100 meters. For snap or quick reaction shooting, especially in poor light, use the upper open rear sight and top of the front sight protector. For precise shooting, use the lower aperture rear sight and the front sight post.

e. To fire: Aim (using the appropriate sight), and press the trigger. The bolt will remain open between bursts and close on an empty chamber when the last cartridge in the magazine is fired. Press the magazine catch toward the magazine and withdraw the magazine.

f. To clear the gun, swing the selector rearward to "S" (safe); remove the magazine by pressing the magazine catch toward the magazine and withdrawing the magazine. Pull the operating handle rearward and release it. Inspect through the ejection port to insure that no cartridges are present. Rotate the selector off safe, pull the operating handle rearward, hold it, and press the trigger. Ease the operating handle and bolt forward, then reset the selector to "S" and insert the magazine.

g. If the Walther MP-K or MP-L malfunctions because of excessive dirt or fouling in the receiver, remove the magazine, set the selector to "D", and press and hold the trigger. Push the operating handle inward to lock it to the bolt, then work the operating handle and bolt back and forth, manually, until the mechanism works freely. Insert the magazine and fire.

97. Disassembly and Assembly

a. Clear the gun (para 96g above) but do not insert the magazine. Open the stock. Press the spring catch in the take-down pin (fig 56) in until the pin can be extracted. (It cannot normally be removed completely from the receiver.) Grasp the upper receiver under the barrel and push it upward to separate the upper and lower receiver.

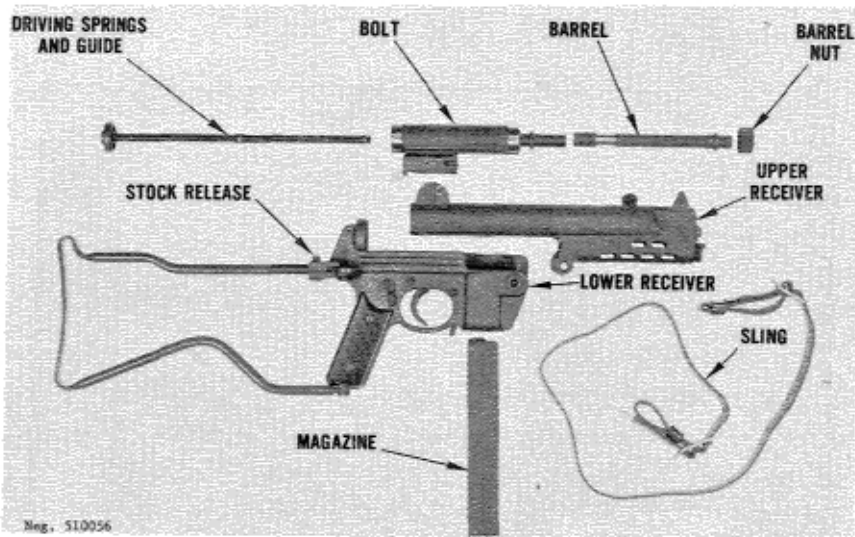

Figure 57. Walther MP-K disassembled.

b. Pull the operating handle rearward to start the bolt out of the receiver, then grasp the driving spring guide and pull the bolt completely out of the receiver. If desired, rest the driving spring guide on a firm surface, hold the bolt, and press in the small spring catch at the front end of the driving spring. Pull the bolt off the driving spring.

c. Depress the barrel nut lock and unscrew the barrel nut (fig 57) and pull the barrel forward, out of the upper receiver. Further disassembly is neither required nor desirable.

d. To reassemble, insert the barrel into the upper receiver, insuring that the semicircular flange on the barrel is seated into its recess in the front end of the upper receiver. Screw the barrel nut on, finger tight. It is not necessary to depress the barrel nut lock. Insert the driving spring assembly into the large opening in the back of the bolt and press it into the bolt until the lock on the front of the driving spring guide (fig 57) snaps into place.

e. Insert the bolt into the upper receiver with the small diameter portion leading (fig 57). Hold the upper receiver at a slight angle to the lower receiver and insert the rear end of the upper receiver and the driving spring into the ring in the lower receiver (fig 57). Force the upper receiver to the rear until it can be fully seated into the lower receiver. Press the takedown pin back into place.

98. Functioning

a. The Walther MP-K and MP-L submachineguns are blowback-operated; refer to paragraph 67a. When the weapon is loaded and the bolt caught to the rear by the sear (fig 58), pressure on the trigger causes the sear to disengage from the bolt. The bolt, under the force of the driving spring, goes forward. The feed rib strips the top cartridge out of the magazine and pushes it into the chamber. As the bolt ends its forward travel, the extractor snaps into the groove of the cartridge, and the fixed firing pin indents the primer, firing the cartridge.

b. The rearward thrust of the fired cartridge overcomes the inertia of the still forward-moving bolt and drives it rearward, compressing the driving spring. The extractor holds the fired cartridge case against the bolt until the case strikes the fixed ejector, which expels the case through the ejection port.

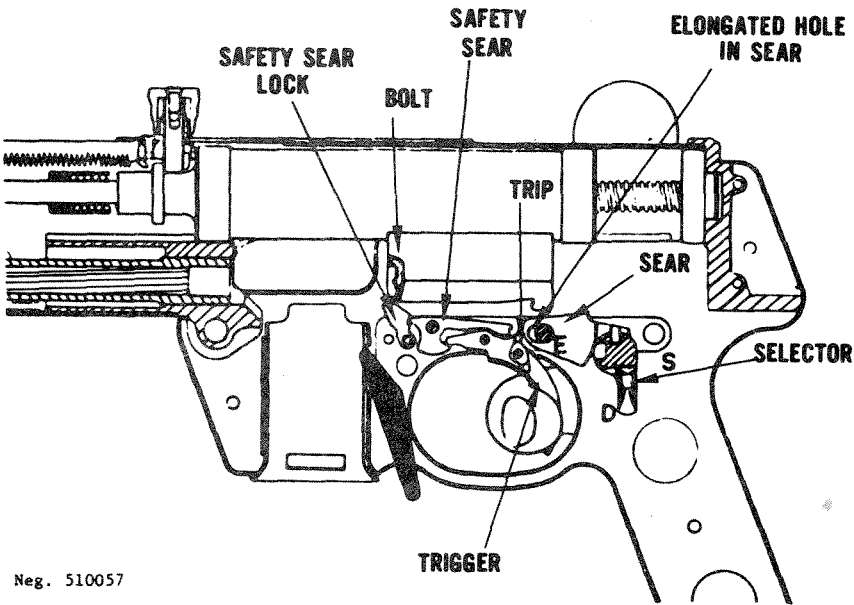

Neg. 510057

Figure 58. Walther MP-K or MP-L section.

c. The trigger mechanism is illustrated in figure 58. The sear not only pivots on its pin, but can also move fore and aft on the pin. The trigger pivots on its pin, and the torsion spring (which returns the trigger forward) has an arm which forces the sear upward and rearward. A trip is also contained within the trigger. The rearward positioning of the sear is determined by the rotation of the selector.

d. When the selector is set on "E" (semiautomatic), the sear is forced, by the trigger spring, to the rearmost position. When the sear nose engages the bolt when the weapon is cocked, the driving spring pressure overcomes the trigger spring, and the sear moves forward until its front end is over the trip in the trigger. As the trigger is pressed, it rotates on its pin, and the trip rises under the front of the sear. As the trip continues to rise, the sear pivots on its pin until the sear nose disengages from the bolt. The bolt, under force from the driving spring, goes forward. Concurrently, the sear, no longer influenced by the driving spring, moves rearward because of the trigger spring and, as the sear moves

rearward, it moves off the trip. When this occurs, the sear pivots about its pin (again due to the force of the trigger spring) and moves up so the sear nose can intercept the bolt. The bolt, recoiling after firing, overrides the sear nose and forces it down against the spring. As the bolt counterrecoils, the spring-loaded sear intercepts the bolt and the driving spring again moves the sear forward. The front of the sear strikes the trip and rotates it around its pin against its spring. The firing cycle now halts. To fire another shot, the trigger must be released. As it is, the trip snaps back under the sear. Trigger pressure will now fire another shot.

e. When the selector is set on "D" (automatic fire), the selector shaft moves the sear forward. As the trigger is pressed, the trip again actuates the sear, but because the selector prevents the rearward movement of the sear, the sear remains depressed and cannot move off the trip. This prevents the sear nose from intercepting the bolt and results in automatic fire.

f. The trigger mechanism contains a safety lever which pivots on the sear pin and is actuated by the trigger. The rear end of the safety lever has a large inward boss. The surface of the selector has two recesses, so that when it is rotated to either "E" or "D" positions, the boss can fit into these recesses. However, when the selector is rotated to the "S" position, there is no recess, and the boss will strike the selector shaft, thus preventing the trigger from moving enough to depress the sear.

g. The trigger mechanism also incorporates a safety sear to intercept the bolt if, during cocking, it is drawn back only far enough to pick up a cartridge from the magazine but not far enough to engage the sear. The spring-loaded safety sear will bear against the bolt until it enters the sear notch. The sear notch is undercut, and a thin nose on the safety sear enters the undercut, locking the bolt and safety sear together. When this occurs, the

only way the bolt can be unlocked is to draw it fully rearward onto the sear. When the trigger is pressed for normal firing, extensions on the front of the trigger depress the safety sear, and the safety sear lock springs rearward over the safety sear to hold it depressed. When the trigger is released, the safety sear lock holds the safety sear depressed until the bolt completes its final forward stroke. As this occurs, the sear lug on the bolt strikes and swings the safety sear lock forward, releasing the safety sear. The safety sear now springs up against the bottom of the bolt and is ready to lock the bolt if it is not fully cocked.

h. The operating handle, when pressed inward against its spring, extends a plunger between the circular rib on the bolt mass and the main body of the bolt. This locks the bolt and operating handle together so that the bolt can be reciprocated manually to clear fouling in the receiver.

99. Accessories

Accessories available for the Walther MP-K and MP-L submachineguns include web slings, spare magazines, magazine carriers, a blank fire device, and a silencer.

J. THE 9-MM H&K MP5 (HK52) SUBMACHINEGUN (WEST GERMANY)

100. General

a. The MP5 submachinegun, developed from the G3 rifle (sec IIIF), has been adopted as a standard arm for the West German Army, border guards, and federal police. The gun is also offered for commercial sale and may be encountered in use by other countries. HK52 is the company designation for the MP5.

b. Because the MP5 was developed from the G3 rifle, the MP5 not only shares many design features with the G3 but also



**Figure 59. West German Heckler and Koch
MP5A2 and MP5A3.**

has many interchangeable parts. There are several versions of the MP5, including the MP5A2 with plastic fixed conventional butt stock and the MP5A3 with sliding metal butt stock (fig 59). Some late model MP5's are equipped with a device which optionally limits automatic fire to three-shot bursts; a silenced version, the HK52SD, is also produced.

c. The MP5 is unique among modern submachineguns in that it commences its firing cycle from a closed, locked bolt and is fired by a swinging hammer. Because of the closed-bolt firing, the MP5 is more accurate than most other 9-mm submachineguns. The MP5 fires 9x19-mm ammunition (sec V).

101. Technical Data

Technical data pertaining to the MP5 will be found in table III.

102. Operation

The MP5 is operated exactly the same as the G3 rifle; refer to paragraph 146.

103. Disassembly and Assembly

The MP5 is assembled and disassembled exactly the same as the G3 rifle; refer to paragraph 147.

104. Functioning

The MP5 functions exactly the same as the G3 rifle; refer to paragraph 148.

105. Accessories

The usual submachinegun accessories are used with the MP5. These include extra magazines and magazine carrier. A special combat carrying sling is available; however, conventional slings can also be used. A blank firing device is also available. This device slips over the muzzle and is locked in place by a quarter turn. A nozzle bolt in the front side of the device may have to be turned to achieve optimum functioning. As the nozzle bolt is turned, it changes the size of the aperture in the blank device.

K. THE 9-MM STEN SUBMACHINEGUN (UK)

106. General

a. The 9-mm Sten submachinegun (fig 60), developed in England early in World War II, was manufactured in enormous

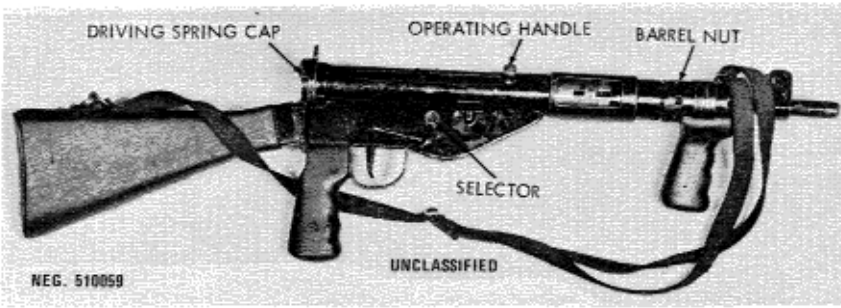

Figure 60. British Mark 5 Sten submachinegun.

quantities. This model, the first simple, cheap submachinegun, was constructed mainly from steel tubing and stampings. Several different models have been produced (fig 61), but all are operated and function in the same manner. The Mark 2 and Mark 5 versions are the most common, and even these will be found with butts and barrels from other models. A silenced version, the Mark 2S (fig 62), was also used.

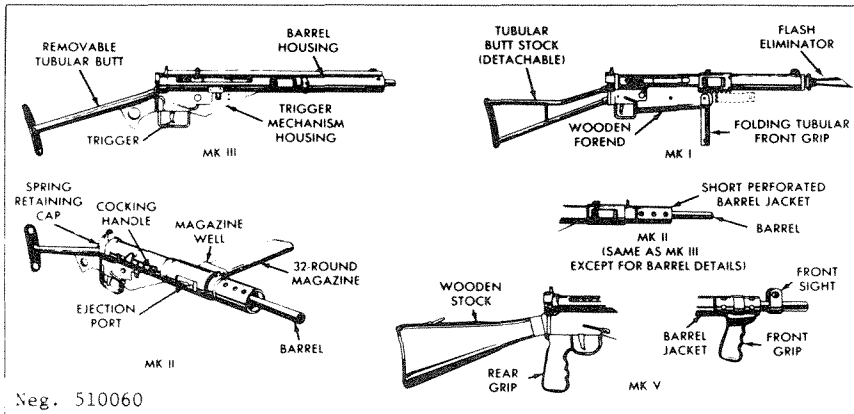

Figure 61. Sten Mark 1, 2, 3 and 5 submachineguns.

b. The Stens, which were freely distributed to underground groups during World War II, are still used by several armies and by clandestine, irregular, or guerrilla organizations. The light weight and compactness of the Sten make it ideal for such use.

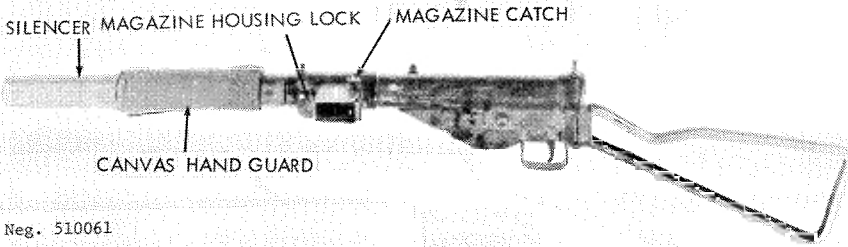

Figure 62. Sten Mark 2S silenced submachinegun.

c. The Stens are blowback-operated, selective-fire, box-magazine-fed, shoulder weapons. The box magazine normally holds 32 rounds of 9x19-mm ammunition (sec V); however, the longer 50-round magazine used in the obsolete Lanchester machine carbine also can be used in the Sten.

107. Technical Data

Technical data concerning the Sten submachineguns are given in table III.

108. Operation

- a. Load the magazine as described in paragraph 47b.
- b. If the magazine housing is in the vertical (storage) position, rotate it to the left until the horizontal position is reached and the housing lock seats in place.
- c. Insert the magazine into the magazine housing until the magazine catch (fig 62) snaps into place. Pull the operating handle

(fig 60) to the rear, and ease it forward until the bolt is caught by the sear. (Note: On some Stens with modified operating handles, the handle must be pulled outward before it can be pulled rearward.) CAUTION: The Sten is now ready to fire.

d. If the submachinegun is not to be immediately fired, put it on safe by drawing the operating handle rearward and then turning it up into the L-shaped safety notch.

e. To fire the gun, select the desired fire mode by pressing the selector (fig 60) in and to the left (for automatic fire) or to the right (for semiautomatic fire). If the gun is on safe, pull the operating handle to the rear, turn it down, and ease it forward until the sear catches the bolt. Using a normal sight picture, aim and press the trigger. The bolt will stay closed when the last round is fired.

f. Remove the magazine by pressing the magazine catch (fig 62) and withdrawing the magazine from its housing. For storage, pull out the magazine housing lock on the front of the magazine housing (fig 62) and rotate the housing to a vertical position.

g. To clear the gun, remove the magazine (f above) and pull the bolt to the rear. Look into the ejection port to insure that no cartridges are present, hold the operating handle, then press the trigger and ease the bolt forward. Press in the operating handle to lock the bolt forward, if the weapon has the modified operating handle.

109. Disassembly and Assembly

a. Clear the submachinegun (para 108g), but do not press in the operating handle. Press in the driving spring cap in the rear

of the receiver; then slide the butt down and off. (Note: Some butts may be a very tight fit.) Press the cap in again and rotate it clockwise as far as possible; ease the cap rearward and remove it with the insert and spring.

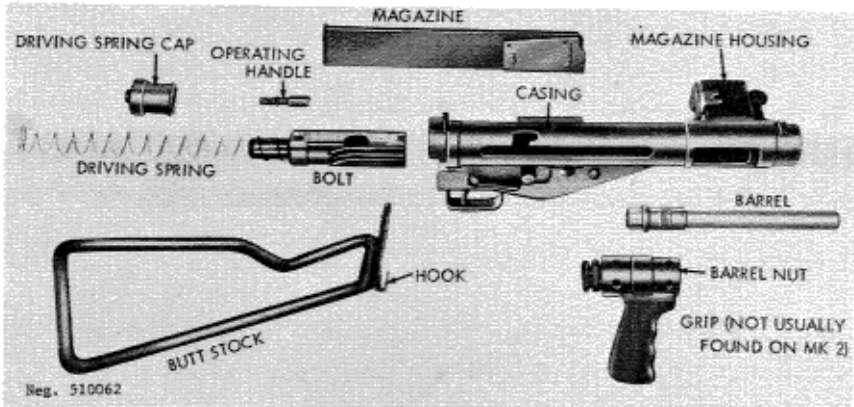

Figure 63. Sten Mark 2 submachinegun, disassembled.

b. Pull the operating handle rearward until it is at the safety cut; turn the handle slightly upward and pull it out of the bolt. Tilt the muzzle up, pull the trigger, and the bolt will slide out of the receiver. No further disassembly of the Mark 1 or Mark 3 submachinegun is necessary or desirable.

c. If the gun is a Mark 2, 2S, or 5 model, unscrew the barrel nut (fig 60) (or the silencer on 2S) and pull the barrel out to the front. The magazine housing should be vertical before this can be done.

d. To reassemble the weapon, insert the barrel and the barrel nut (or silencer) into the receiver; insure that the Mark 5 barrel aligns with the receiver keyway. Hand tighten the barrel nut and turn the magazine housing to the horizontal.

e. Insert the bolt into the receiver, with the extractor aligned with the operating slot. Pull the trigger and push the bolt forward until the hole for the operating handle is at the safety cut. Insert the operating handle, turn it down, pull the trigger, and push the bolt forward.

f. Slide the driving spring over the rear of the bolt and place the cap and its insert over the exposed end of the spring. Align the lugs of the cap with the slots in the receiver, press the cap and insert in as far as possible, and rotate the cap clockwise to lock it.

g. Place the butt in place, using the loop on the butt to depress the cap. Slide the butt upward until its hook seats into the receiver and the insert snaps into place.

110. Functioning

a. The Sten submachineguns are blowback-operated.

b. When a loaded magazine is in place and the gun is cocked and set for automatic fire (fig 64), pressure on the trigger moves the trigger bar (fig 64) forward. A notch in the trigger bar mates with the lower end of the L-shaped sear (fig 64), and as the trigger bar moves forward, it will cause the sear to rotate about its pin and release the bolt. The driving spring drives the bolt forward to strip a round from the magazine and drive it into the chamber. The fixed firing pin strikes the primer and fires the cartridge when it is fully chambered.

c. The fired cartridge, acting like a piston, drives the bolt back and compresses the driving spring. The extractor holds the cartridge case in place in the bolt face until the case strikes the fixed ejector in the left wall of the receiver. The case is expelled through the ejection port.

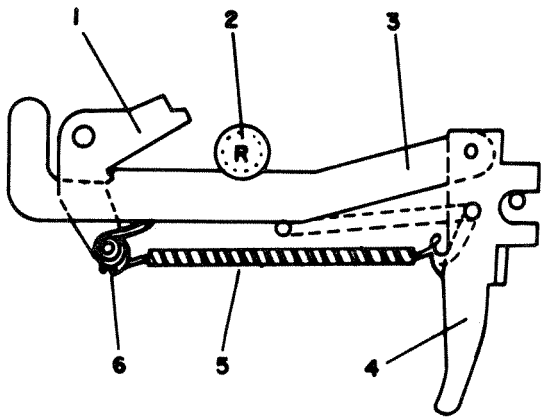

SIDE

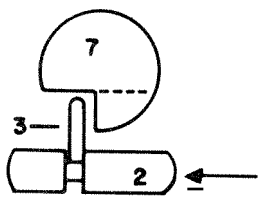

A - AUTOMATIC FIRE

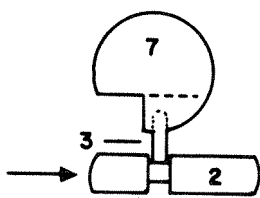

B - SEMIAUTOMATIC FIRE

FRONT

- 1 - SEAR
- 2 - SELECTOR
- 3 - TRIGGER BAR
- 4 - TRIGGER
- 5 - TRIGGER SPRING
- 6 - TRIGGER SPRING CONNECTOR
- 7 - BOLT

Neg. 510063

Figure 64. Sten Trigger Mechanism

d. When the trigger is released, the trigger spring (fig 64) returns the trigger forward, and as the trigger bar moves to the rear, the front end of the trigger spring moves the sear to where it can intercept the bolt and stop the firing.

e. When the weapon's selector is set at semi-automatic (fig 64), the trigger bar is moved from its normal off-side location in the receiver to a central position. When the trigger is pressed, the trigger action is as described in paragraph b above; however, a cam on the bottom rear of the bolt acts on an extension of the trigger bar and forces the trigger bar out of engagement with the sear. The sear then returns to its normal position and intercepts the bolt so that only one shot is fired. The trigger must be released to allow the trigger bar to move rearward and reengage the sear prior to firing another shot.

111. Accessories

A simple canvas sling, spare magazines, a magazine filler, and a cleaning rod are usually available for use with Sten guns.

L. MISCELLANEOUS SUBMACHINEGUNS

111.1. General

There are probably more different types of submachineguns in use than any other kind of weapon. In addition to the guns previously covered in this guide, there are a few guns that may be encountered which, because of their relative scarcity or age, do not warrant full coverage but are included for identification only.

111.2. The Belgium Vigneron Submachinegun

The Vigneron submachinegun was used only by the Belgium Armed Forces and will be found in use by many of Belgium's former colonies. The Vigneron (fig 64.1), fires the 9x19-mm cartridge and can be recognized by its lean appearance, annular rings on the barrel, sliding tubular butt, and sling ring on the receiver rear.



Neg. 532351

Figure 64.1. The Belgium Vigneron Submachinegun

111.3. The Portuguese F.B.P. M/48 Submachinegun

The F.B.P. M/48 submachinegun (fig 64.2) is used by the Portuguese Army and will be found in many of Portugal's former colonies. The F.B.P. M/48 is similar in design to the UK Sten (para 106) and can be recognized by its stepped barrel with a prominent bayonet lug halfway along its length, and the tapered trigger mechanism housing.

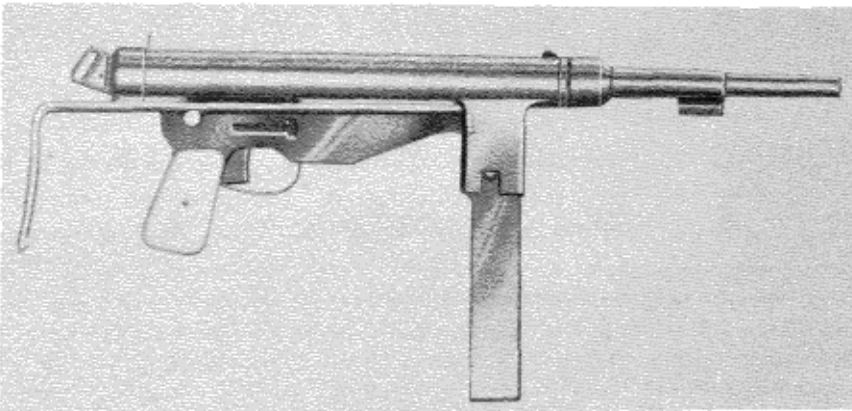

Neg. 532352

Figure 64.2. The Portuguese F.B.P. M/48 Submachinegun

111.4. The South Korean K-1 Submachinegun

The South Korean K-1 submachinegun (fig 64.3) is used by units of the Korean Special Warfare Command. It fires a 5.56-mm cartridge and has a three-round burst option, in addition to full automatic and semiautomatic modes. It has a telescoping wire stock that locks in three positions: Closed, half-opened, and fully-opened. The receiver group and many of the internal parts are based on the US M-16 design. The cone-shaped flash suppressor will probably be replaced on future models of the K-1. Technical details for this weapon are provided in table III (page 125).



Neg. 533236

Figure 64.3. South Korean K-1 Submachinegun

M. MAINTENANCE

112. Care and Cleaning

The procedure and materials prescribed for cleaning standard US Army submachineguns also apply to foreign submachineguns. These weapons should be disassembled only to the extent necessary for adequate cleaning, in order to prevent breakage and subsequent loss of use. Other than the replacement of parts, which should be done only by a competent armorer, no repairs should be attempted on foreign submachineguns.

3 February 1984

113. Malfunctions and Stoppages

Most malfunctions and stoppages are caused by defective magazines. Table IV lists common problems and their remedies. Malfunctions caused by broken or worn parts can be corrected by replacing the defective part with a serviceable one. This should be done only by a competent armorer, and the repaired weapon must then be function test fired.

Table III. Submachinegun Technical Data

Weapon	L2A3	UZI	M.A.T. 49	Madsen M50	M45b	Beretta M4	Beretta M12	Steyr M69	Walther MP-K/MP-L	H&K MP5	Sten MK2	K1
Length, stock open (mm)	685	640	711	800	808	790	645	670	635/737	660	762	770
Length, stock folded (mm)	482	455	553	528	551	N/A	417	465	368/455	490	N/A	585
Weight, empty (kg)	2.72	3.5	3.5	3.15	3.45	3.3	3.0	2.9	2.8/3.0	2.5	3.0	2.75
Barrel length (mm)	198	260	228	198	203	210	200	260	171/257	225	196	263
Magazine capacity (rd)	34	25, 32, or 40	32	32	32	20 and 40	20, 30, or 40	25 and 32	32	30	32	20, 30
Fire-type	Selective	Selective	Automatic	Automatic	Automatic	Selective	Selective	Selective	Selective	Selective	Selective	Selective
Muzzle velocity (m/s) ¹	390	435	350	390	400	400	390	435	356/396	400	395	820
Practical range (m)	200	200	100	100	200	100	100	220	100	200	200	250
Rate of fire, semi-automatic (rd/min)	45-50	40-50	N/A	N/A	N/A	40-50	40-50	50	40-50	40-50	40	---
Rate of fire, automatic (rd/min)	80-100	80-100	90	100	100	100	100	100-120	100	100	100	---
Rate of fire, cyclic (rd/min)	550	600	600	550	600	450-500	550	550	550	650	575	700-900

¹May vary + or - 50 m/s, depending upon ammunition.

126.2

Table IV. Submachinegun Malfunctions

Condition	Cause	Remedy
Fails to fire (cartridge in chamber)	Defective cartridge	Retract bolt and fire
	Weak driving spring	Replace spring
Fails to fire (no cartridge in chamber)	Defective magazine	Replace magazine
	Short recoil	Clean and lubricate
	Fouled weapon	Clean and lubricate
Fails to eject	Fouled weapon	Clean and lubricate



SECTION III. RIFLES

A. THE 5.56-MM C.A.L. ASSAULT RIFLE (BELGIUM)

114. General

a. The 5.56-mm C.A.L. assault rifle (fig 65) was developed by the Fabrique Nationale Company of Belgium as a weapon to supplement their FN/FAL rifle (paragraph 126). Although the initials C.A.L. stand for Carabine Automatique Legere/Light Automatic Carbine, this weapon is considered an assault rifle by US standards. The C.A.L. can be fitted with either a conventional or a folding metal butt stock (fig 66).

b. The C.A.L. is a gas-operated, magazine-fed weapon capable of semiautomatic, full-automatic, or three-shot burst fire. An adjustable gas regulator permits the rifleman to increase the quantity of operating gas if the rifle is dirty or used under adverse conditions. The flash suppressor is used as a grenade launcher, and a cutoff valve is used to prevent breech mechanism functioning when launching grenades. An accessory 40-mm grenade launcher is also available. The C.A.L. fires 5.56x45-mm ammunition (US 5.56 M193) (sec V) and 22-mm tubed rifle grenades. When the accessory 40-mm grenade launcher is fitted, US 40-mm grenades can be fired.

115. Technical Data

Technical data concerning the C.A.L. will be found in table V.

116. Operation

a. Remove the magazine by pressing the magazine catch (fig 66); the magazine will eject. Load the magazine by placing a cartridge on the magazine follower and press the cartridge down until it rolls sideways under one of the feed lips. Repeat until the magazine is full (20 rounds).

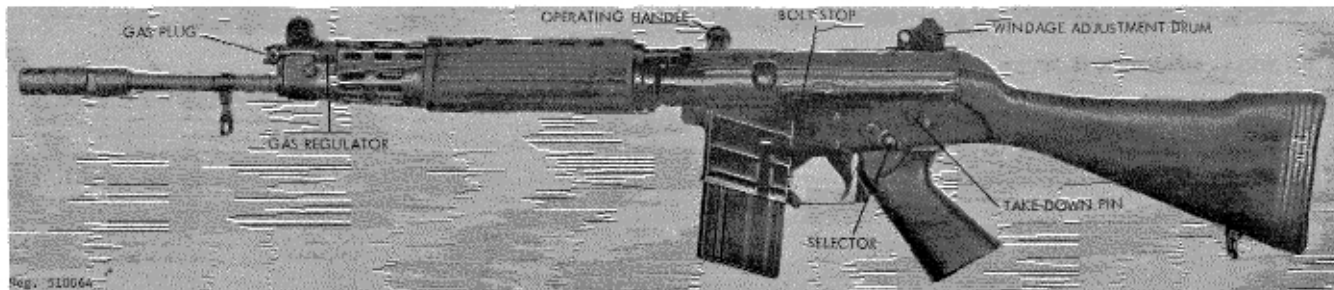

Figure 65. Belgium C.A.L. assault rifle.



Figure 66. C.A.L. with folding metal butt stock.

b. Insert the loaded magazine into the receiver until the magazine catch snaps into place and retains the magazine. Insure that the “A” on the gas plug faces up (fig 65).

c. Rotate the selector (fig 65) to “S” (safe), pull the operating handle fully rearward, and release it. CAUTION: The rifle is now loaded and ready to fire. To fire, place the selector on the desired setting: 1 for semiautomatic fire, 3 for three-shot burst automatic fire, or A for fully automatic fire. Aim (using a normal sight picture), and squeeze the trigger. The weapon will fire according to the chosen selector setting. The bolt will remain closed between shots and will open when the last round is fired.

d. When the bolt is caught to the rear after the last round is fired, it can be closed by (1) removing the magazine (a above) and pulling the operating handle (fig 65) rearward and releasing it; or (2) pressing in on the bolt stop (fig 65).

e. Clear the C.A.L. by setting the selector on safe, removing the magazine (a above), and, while holding the bottom of the bolt stop (fig 65) inward, pull the operating handle rearward and release it; the bolt will be caught to the rear by the bolt stop. Inspect to insure that no cartridges are present in the barrel or receiver. Press the top of the bolt stop inward to release the bolt, rotate the selector off safe, press the trigger, and then rotate the selector back to safe. Insert the magazine.

f. To adjust the gas regulator (fig 65), rotate the regulator to the left until the oblong gas vent, located behind the front sight hose, is uncovered, then close the regulator two clicks. Load the rifle (with a magazine containing one cartridge) and fire. If the bolt is not caught to the rear, close the regulator an additional click and fire another single round. Repeat until the bolt is caught to the rear, then close one additional click. If the rifle becomes fouled during use, close the regulator one click at a time until reliable functioning occurs.

g. Prior to firing rifle grenades, rotate the gas plug (fig 65) to shut off the gas. Press in on the plunger and rotate the plug so that the letter "A" on the plug is toward the barrel. With the plug in this position, the rifle must be manually reloaded for each shot. To again fire normally, press in the lock and rotate the gas plug until the "A" is upward.

h. The front sight can be screwed up or down to adjust for elevation. Rotate the sight clockwise (in) to raise the bullet's point of impact. The adjustment drum (fig 65) on the rear sight can be rotated to adjust for windage (lateral) zero. Turning the drum clockwise moves the point of bullet impact to the right.

117. Disassembly and Assembly

a. Clear the rifle (para 116e) but do not reset the selector to safe or insert the magazine.

b. With the bolt forward, firmly pull the operating handle to the right; it will move about one-quarter of an inch. (If necessary, use a cartridge between the operating handle and receiver to pry the handle outward.) Press out the takedown pin to the right and swing open the weapon (fig 67). Pull the operating handle fully rearward (it should not have any spring tension), then pull it out of its slot in the receiver. Place a hand behind the

receiver, elevate the muzzle, and catch the bolt as it starts out of the receiver. Remove the bolt.

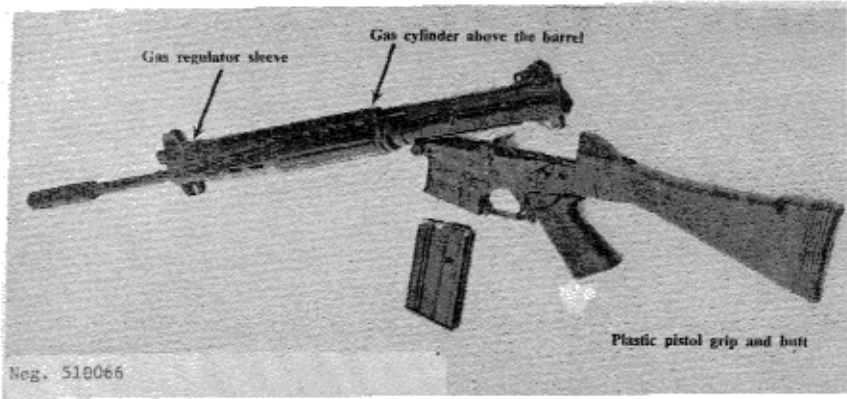

Figure 67. C.A.L. open for disassembly.

c. Press in the lock on the gas plug (fig 65), rotate the plug until the letter "A" is to the left, then ease the plug out to remove it. Point the muzzle down and catch the piston assembly as it comes out of its tube.

d. Push the bolt fully into the bolt carrier (fig 68). Use a small punch or a nail to push the firing pin retainer out from left to right. Point the bolt upward and catch the firing pin as it falls free. Remove the cam pin (fig 68). Pull the bolt and carrier forward from the slide, then twist the bolt until it can be pulled forward out of the bolt carrier. Slide the carrier rearward in the slide (fig 68) until the bolt parts separate.

e. No further disassembly is required or desirable for cleaning.

f. To reassemble, first mate the bolt carrier to the slide and shove the carrier as far forward as possible. Insert the bolt into

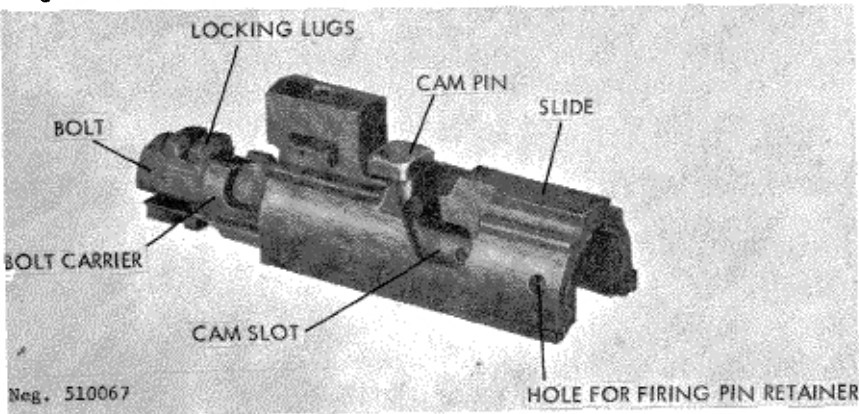

Figure 68. C.A.L. bolt.

the carrier and twist the bolt until the lug on its side enters the bolt carrier. When the bolt enters the carrier, again twist the bolt so that the lug enters its recess on the top of the slide. Push the bolt and carrier into the slide until the cam pin hole in the bolt aligns with the cam slot of the slide (fig 68). Insert the cam pin. Insert the firing pin, insuring that the cam on the firing pin head is upward. Push the bolt and carrier fully into the slide and, after fully seating the firing pin, insert the firing pin retainer from right to left.

g. Hold the rifle muzzle up and drop the piston assembly, small end first, into the opening under the front sight. Place the plug (fig 65) into the hole with the large end of the lock toward the barrel, then turn the plug until its stamped letter "A" is up. Depress the lock while turning the plug.

h. Pull the bolt and carrier forward in the slide and insert the bolt assembly into the receiver. Align the rear of the operating handle slot in the receiver with the slot in the bolt and insert the operating handle. Slide the bolt unit fully forward and, with a sharp blow of the hand, fully seat the operating handle. Pull the

operating handle rearward to insure that it has coupled the bolt unit to the driving spring; spring pressure should resist the pull of the operating handle.

i. Swing the receiver shut and push the takedown pin inward. Insert the magazine.

118. Functioning

a. The C.A.L. is gas operated; some of the gas that drives the bullet down the barrel is tapped off and directed against a piston to drive it to the rear. The piston is connected to the mechanism of the gun and imparts sufficient energy to the mechanism to perform all functions necessary to fire a succeeding shot.

b. When the piston is driven rearward, the slide moves rearward. After short travel, the cam cut in the slide contacts the cam pin (fig 68). Continued movement of the slide causes the cam pin to rotate on the cam; this rotation causes the bolt to rotate in the bolt carrier. The firing pin does not rotate with the bolt and, as the bolt rotates, a cam on the end of the bolt causes the firing pin point to retract into the bolt.

c. As the bolt rotates, the locking lugs (fig 68) (formed as a segment of a screw) unscrews from the locking bushing. The powerful camming action, resulting from the unscrewing, causes the bolt to move slightly rearward; the extractor, moving the bolt, loosens the fixed cartridge from the chamber walls. When the bolt is fully disengaged from the locking bushing, the slide strikes the bolt carrier and starts the bolt carrier and bolt rearward. The extractor pulls the fired cartridge from the chamber and holds it to the bolt until the ejector strikes the case and expels it through the ejection port.

d. The driving spring is compressed and the hammer rocked rearward during the rearward travel of the slide. When the slide strikes the rear wall of the receiver, rearward motion ceases and the driving spring then forces the slide and related parts forward.

e. As the bolt goes forward, its feed rib drives the top cartridge out of the magazine, up the feed ramp, and into the barrel. The bolt stops, but the slide continues forward; as it does, the slide cam causes the cam pin and bolt to rotate. The bolt screws into the locking bushing and, as it does, the extractor snaps over the rim of the cartridge. The slide strikes the barrel bushing and stops.

f. The selector controls the type of fire (automatic, three-shot burst, semiautomatic, or safe). Cuts in the shaft of the selector align a lug on the trigger with a projection on the sear to permit each mode of fire. The selector also controls the operation of the three-shot burst mechanism.

g. A safety sear holds the hammer cocked until the slide strikes the safety sear. This releases the hammer; resultant action depends upon selector setting. When the selector is set on Safe, a solid portion of the selector shaft blocks the trigger tit and prevents trigger motion.

h. When the selector is set on 1 (semiautomatic), the trigger lug can fit into one of the cuts on the selector shaft. As the trigger is pressed and rotates about its pin, the front hook of the trigger swings forward to release the hammer which, under force of its spring, swings forward and strikes the firing pin to fire the round. The spring-loaded sear also rotates forward with the trigger. When the hammer is rocked back (by the recoiling slide), the hammer rides past the sear but is caught by the sear when the slide returns forward. When the trigger is released, the front hook of the

hammer and the sear rotate rearward. The sear releases the hammer, which swings forward and is caught by its front hook. To fire another shot, the trigger must be repressed.

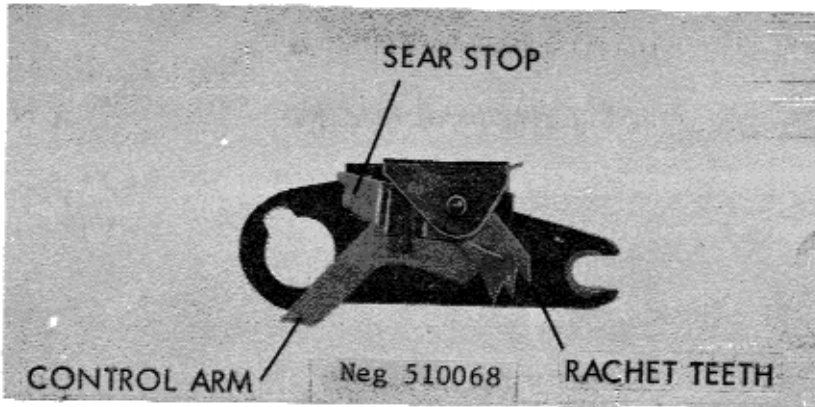

Figure 69. C.A.L. burst limiter.

i. When the selector is set to 3 (three-shot burst), the basic action is identical to the semiautomatic mode as described in "h" above; however, the selector moves the rear of the control arm of the burst limiter (fig 69) downward. This causes the ratchet teeth in the front of the control arm to move up into contact with a pawl on the hammer. When the hammer falls, the pawl lifts the front of the control arm, and the rear of the control arm swings the sear stop (fig 69) down to block the sear to the rear, where it cannot engage the hammer. Because the sear does not engage the hammer, only the safety sear holds the hammer cocked and, when the slide counterrecoils, the sear trip is actuated by the slide to release the hammer. As the hammer swings to fire the second shot, its pawl lifts the control arm one more space. When the hammer fires the third cartridge, the control arm is lifted far enough to release the sear stop. The sear stop, in turn, releases the sear which intercepts the hammer and stops the firing cycle. To fire another burst, the trigger must be released and repressed.

j. When the selector is set at "S" (safe), a solid portion of the selector shaft rotates over the tip on the trigger and prevents the trigger from being pressed far enough to release the hammer.

119. Accessories

a. The C.A.L. uses a number of accessories. These include a spike bayonet, a bipod, telescopic and infrared sights, and a 40-mm grenade launcher.

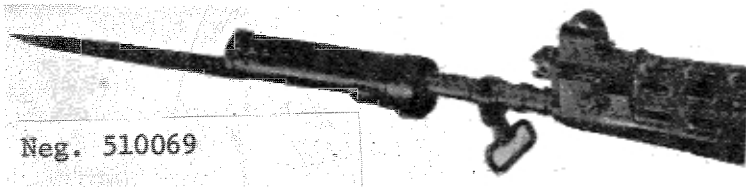

Figure 70. C.A.L. bayonet.

b. Affix the bayonet (fig 70) by sliding it over the flash suppressor until the catch locks onto the back of the suppressor. To remove the bayonet, push the catch out of engagement and pull the bayonet forward off the weapon.

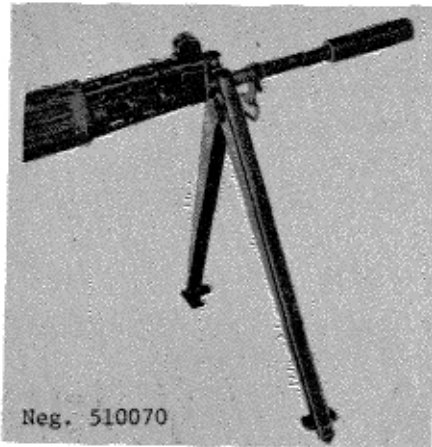

Figure 71. C.A.L. bipod.

3 February 1984

c. The bipod (fig 71) is attached by squeezing the legs together and, after aligning the clamp section with the barrel, releasing the legs. Squeeze the legs together to remove the bipod.

d. The telescopic sight and the infrared sight are attached by fitting them to the rear sight base, then screwing the clamp screw on the sight into the rear sight base.

e. The 40-mm grenade launcher attachment is still under development, and its operation is still subject to change. It will not be further covered.

B. THE 5.56-MM HECKLER AND KOCK HK 33 AND HK 53
ASSAULT RIFLES (WEST GERMANY)

120. General

a. The HK 33 (fig 72) and HK 53 (fig 73) rifles are reduced-size versions of the West German G3 rifle (sec F). The HK 33 and HK 53 differ mainly in the much shorter barrel of the latter. The HK 33, when fitted with a shorter barrel and a sliding metal stock, is known as the HK 33K (fig 72). The HK 53 can be fitted with either a conventional or sliding metal stock similar to that of the HK 33K. A plastic cap, to fit over the end of the receiver in lieu of either type of stock, is also available for the HK 53.

b. The HK 33 and HK 53 are selective-fire, delayed-blowback-operated weapons fed from 20- or 40-capacity magazines. These weapons are reduced-size versions of the 7.62-NATO caliber G3 assault rifle, and many HK 33/53 and G3 parts are interchangeable.

c. The HK 33 and HK 53 fire the 5.56x45-mm ammunition (sec V).



Neg. 510071
Figure 72. West German HK 33 Rifles



Neg. 510072
Figure 73. West German HK 33K
and HK 53

121. Technical Data

Technical data pertaining to the HK 33 and HK 53 will be found in table V.

122. Operation

Operate the HK 33 and HK 53 weapons exactly the same as the G3 assault rifle (para 146).

123. Disassembly and Assembly

The HK 33 and HK 53 weapons are disassembled and assembled in exactly the same manner as the G3 assault rifle (para 147). Under no circumstances should locking cams be interchanged between weapons of different calibers. Such interchange could kill or injure the shooter.

124. Functioning

The HK 33 and HK 53 function exactly the same as the G3 (para 148).

125. Accessories

In general, the HK 33 and HK 53 use the same accessories as the G3 (para 149). The bayonet cannot be affixed to the HK 53, and the cleaning equipment is adapted to the small diameter bore of the HK 33 or 53.

C. THE 7.62-MM FN/FAL RIFLE (BELGIUM, UK, ETC.)

126. General

a. The 7.62-mm FN/FAL rifle (fig 74) was developed by the Fabrique Nationale (FN) Arms Factory in Belgium. This gas-operated, selective-fire, magazine-fed, shoulder weapon is one of the most widely distributed rifles in the free world. It is produced in Belgium, Great Britain, Canada, Australia, India, Israel, Austria, and Argentina and, in addition, is used by the Netherlands, Luxembourg, New Zealand, Chile, Venezuela, Peru, Ecuador, Ireland, the Congo, West Germany, and Cuba. The FAL, obtained by commercial purchase or capture, is also often found in use by dissident groups.

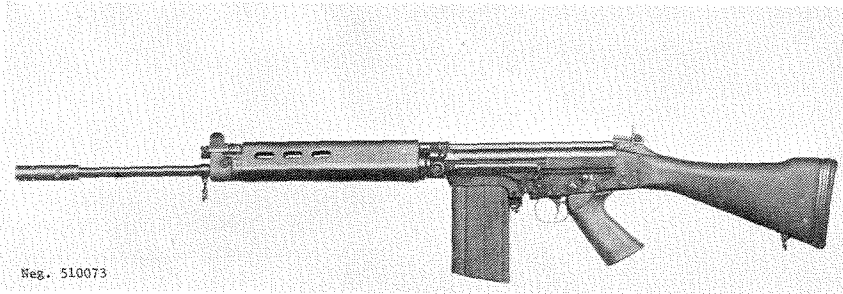

Figure 74. Belgium FN/FAL rifle.



Figure 75. FN/FAL with metal forearm and bipod.

b. Several modifications may help to determine the origin of a particular FAL. The West German G-1, the Austrian StG58, and the Dutch FAL all have a lightweight, folding metal bipod incorporated in their metal forestock (fig 75); the British L1A1 and Indian Ishapore rifles (fig 76 and 77), capable of

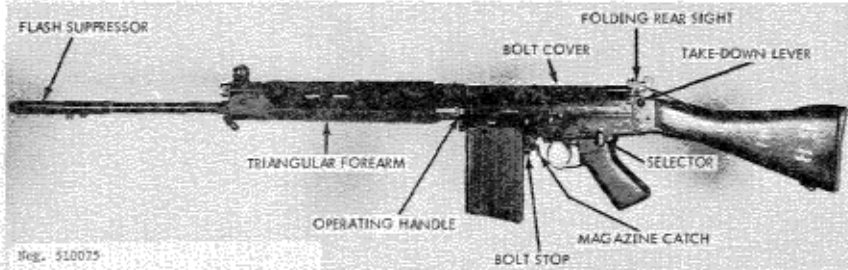

Figure 76. British L1A1 rifle.



Figure 77. Indian Ishapore rifle.

semiautomatic fire only, have zigzag dirt clearance cuts in the bolt carriers, folding operating handles, and enlarged magazine catches and selectors. In addition, the FAL are found with or without flash suppressors, with different types of bolt covers, and with a forearm of several different styles (fig 78). It is often difficult to identify the original purchasing nation of an FAL unless the rifle is stamped with an identifying seal or crest.

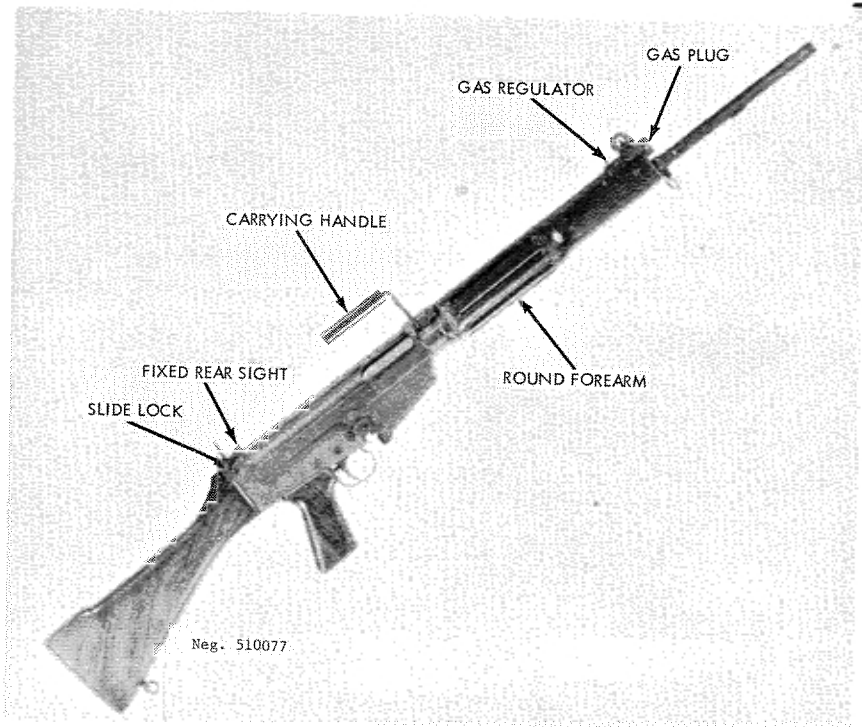

Figure 78. FN/FAL rifle, early version.

c. All FAL's use the same basic design mechanism, except for the folding-metal-stock parachutist version (fig 79). This model has its driving spring housed in the top of the bolt carrier instead of in the butt stock.

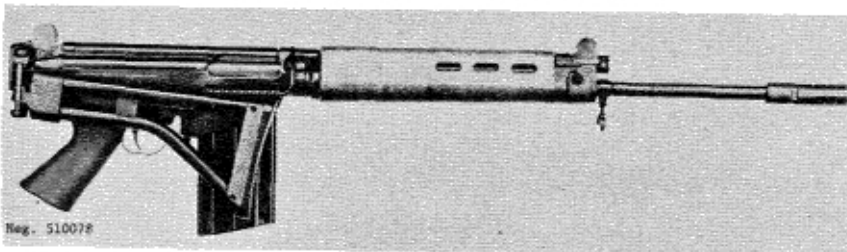

Figure 79. FN/FAL paratrooper's model.

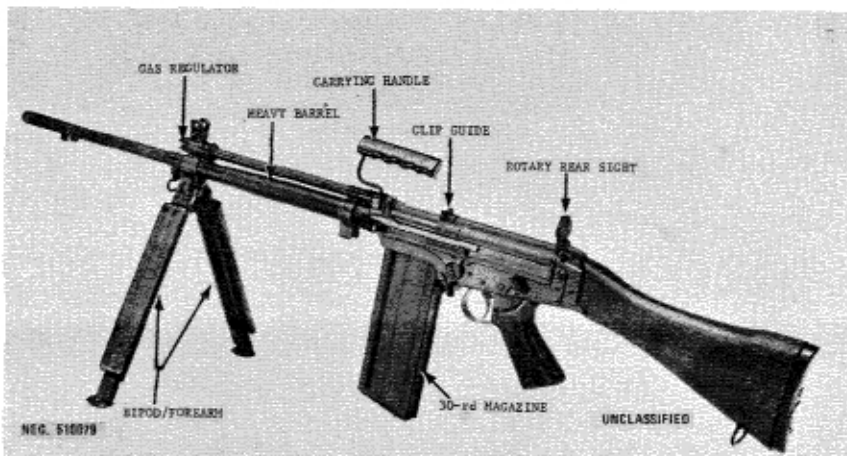

Figure 80. Canadian C2A1 automatic rifle.

d. When equipped with a sturdy bipod and a heavy barrel, the FAL (FALO) is used as an automatic rifle or light machinegun. The Canadian C2A1 (fig80) and the FAL automatic rifles (fig 81) and 82) are examples of such weapons. The instructions given for the regular FN/FAL rifle are also applicable to these automatic rifles. All FN/FAL rifles fire the 7.62x51-mm NATO cartridges (sec V).



Figure 81. FN/FAL (FALO) AUTOMATIC RIFLE

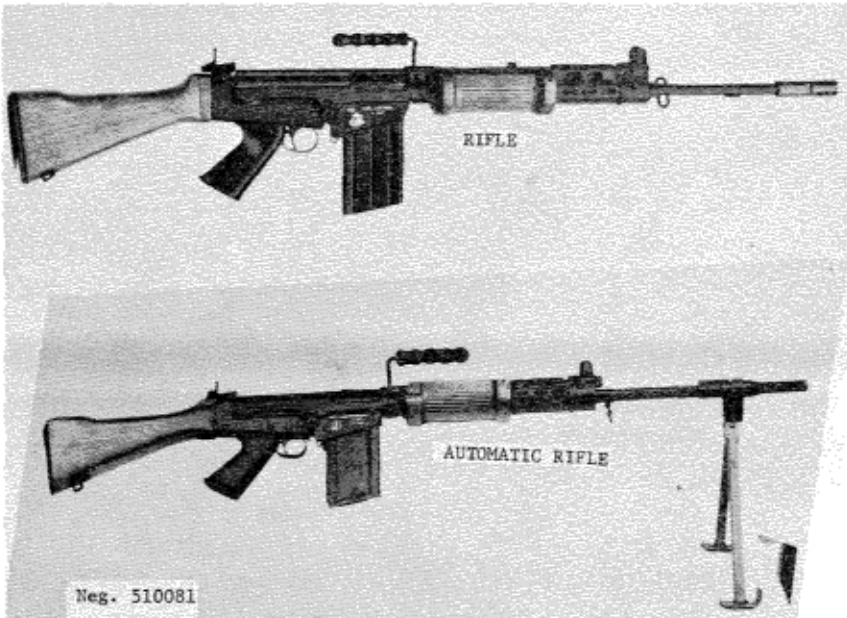

Figure 82. Israeli FN/FAL rifle and automatic rifle.

127. Technical Data

Technical data pertaining to the FN/FAL rifle are given in table V.

128. Operation

a. Load the magazine by placing a cartridge on the magazine platform and pressing down until the cartridge rolls sideways under one of the feed lips. Repeat this action until the magazine is full.

b. Grasp the magazine by its base, and while holding it at a slight forward angle to insure that the lip on the top front of the magazine engages its seat in the receiver, insert the magazine into the magazine housing. Pull the bottom of the magazine to the rear until the magazine catch (fig 83) snaps into place.



Figure 83. L1A1 receiver details.

c. Rotate the selector (fig 83) to its upper rear position (safe). Grasp the operating handle (fig 83) (unfolding it if necessary), pull it fully to the rear, and release it. CAUTION: The rifle is now loaded.

d. Adjust the rear sight for the desired range by unfolding (if necessary), by pressing in the slide lock (fig 83), and by sliding the aperture on its base until the number that corresponds to the range, in hundreds of meters, is visible.

e. Rotate the selector to the desired position, down for semiautomatic or fully forward for full automatic. (Note: Some FAL's can fire only semiautomatically.) Using a normal sight picture, aim and press the trigger. The bolt will remain open when the last shot is fired.

f. Remove the magazine by pressing the magazine catch (fig 83) forward and, at the same time, rotate the magazine forward out of the gun. The bolt can be closed by pulling the

operating handle fully to the rear and then easing it forward or by pressing down the bolt stop (fig 83).

g. Clear the FAL by removing the magazine (f above), pressing up on and holding the bolt stop (fig 83), and then pulling the operating handle fully to the rear and releasing it. The bolt will remain open; inspect to insure that no cartridges are present. Move the selector from safe, depress the bolt stop, press the trigger, set the safety back on safe, and reinsert the magazine.

h. There are two types of gas regulators (fig 78), both of which are adjustable. Both function in the same manner but are adjusted differently. The older type regulator has a square forward face; move this type back until it just uncovers the oval gas escape port behind the front sight. Insert an empty magazine, close the regulator 20 clicks, load a live round into the chamber, and fire. If the bolt does not catch to the rear, close the regulator five more clicks and refire. Continue this action until the bolt is just caught to the rear, for five consecutive shots; then close the regulator three additional clicks. If the gun fails to reload after it has been fired, close the regulator two clicks at a time until reliable functioning is achieved. The new style regulator has an angled cut on its forward face and is easier to adjust. Move this regulator back until the gas escape port is uncovered; then, with an empty magazine in place, fire one cartridge; if the bolt does not catch to the rear, close the regulator one click and refire. Repeat (and adjust if necessary) until the bolt is caught for five consecutive shots; then close the regulator one more click. When a weapon in use fails to reload, close the regulator one click at a time until proper functioning is achieved. In all cases, note the correct setting for future use.

i. The gas plug (fig 78) is adjustable for firing rifle grenades. Press in the plunger on the plug and rotate it to the

desired position. The rifle will function normally when the letter or symbol on the plug is at the top. When it is at the bottom, or if the letters "GR" are visible, the gas port is closed (for firing grenades), and the rifle must be manually reloaded after each shot.

j. The front sight can be screwed up or down to adjust for elevation zero. Screw the sight clockwise (inward) to raise the point of impact. The rear sight can be zeroed laterally by means of the screws (fig 83) directly under it. Loosen one screw and tighten the opposing screw to move the sight. The sight will move toward the loosened screw, in the direction the shot pattern is to be moved.

129. Disassembly and Assembly

a. To disassemble the weapon, clear the rifle (para g) but do not press the trigger or insert the magazine.

b. The takedown lever (fig 83) may be either the older vertical type or the newer horizontal type. Press the former to the rear, press the latter upward, and while holding the FAL by its handguard, press the butt stock down to swing the rifle open.

c. Pull the bolt cover (fig 83) to the rear, off the receiver.

d. Grasp the rod that extends from the rear of the bolt carrier and pull the bolt and carrier to the rear out of the receiver. Hold the bolt carrier horizontally and push the bolt back into the carrier until the bolt drops. Press in on the end of the firing pin, and the bolt will drop clear of the carrier.

e. Use the point of a cartridge or similar item to force in the plunger on the side of the gas plug (fig 78). Rotate the plug until it comes free; remove the plug, the piston, and the piston spring.

f. No further disassembly is necessary or desirable.

g. To reassemble the rifle, insert the piston and spring into their tube and force them into place with the gas plug. The lugs on the plug must be vertical; after the plug is in as far as possible, depress its plunger and rotate the plug to retain it in place. (Note: Refer to para 128i.)

h. Holding the bolt at an angle, insert it into the bolt carrier so that the firing pin enters its hole in the rear end of the carrier. Press the bolt to the rear (while pressing in on the protruding end of the firing pin) until the bolt seats in the carrier.

i. Hold the opened rifle muzzle down, and, after insuring that the bolt is forward in the carrier, align the rails of the carrier with their grooves in the receiver and slide the carrier fully forward. Mate the bolt cover with its grooves in the receiver and slide the carrier fully forward.

j. Swing the rifle shut, pull the trigger to release the hammer, place the selector to safe, and insert the magazine.

130. Functioning

a. The FN/FAL rifle is gas operated; some of the gas that drives the bullet down the barrel is tapped off and directed against a piston to drive it to the rear. The piston imparts sufficient energy to the mechanism of the gun so that all functions necessary to fire another shot are performed.

b. When the trigger is pressed, the hammer strikes the firing pin; this fires the cartridge, and the propellant gases drive the bullet down the bore. After the bullet passes the gas port in the barrel, some of the gases enter the gas cylinder and drive the

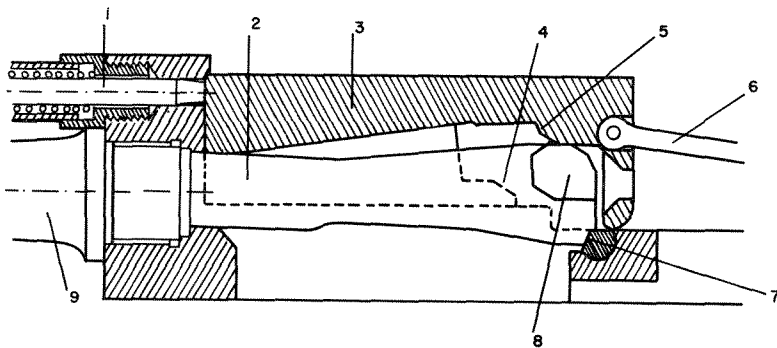

- | | |
|-------------------|------------------------|
| 1 - PISTON | 5 - LOCKING CAM |
| 2 - BOLT | 6 - DRIVING SPRING ROD |
| 3 - BOLT CARRIER | 7 - LOCKING SEAT |
| 4 - UNLOCKING CAM | 8 - LUGS |
| | 9 - BARREL |

№. 510083

Figure 84. FN/FAL bolt mechanism.

piston rearward. The piston strikes the bolt carrier (fig 84) and drives it rearward, compressing the driving spring. After a short free travel, the bolt carrier unlocking cam (fig 84) cams the bolt up out of its locking seat in the receiver. The bolt and carrier now travel to the rear as one unit.

c. The piston spring returns the piston forward, and the bolt carrier rocks the hammer back. The extractor pulls the fired cartridge case from the chamber and holds it against the bolt until the case strikes the ejector. The case is expelled from the rifle.

d. The driving spring forces the bolt and bolt carrier forward; the feed rib on the bolt drives a cartridge out of the magazine and into the chamber. The extractor snaps over the rim of the cartridge, and the bolt stops its forward travel. The bolt carrier continues forward for a short distance, and by means of the locking cam (fig 84), cams the bolt down into its locked position. The carrier finally trips the automatic sear (fig 84).

e. The selector (fig 85) controls the type of fire by permitting different amounts of trigger travel according to the selector setting. When on safe, the solid shaft of the selector is over the rear of the trigger, and the trigger cannot be pulled to fire the rifle.

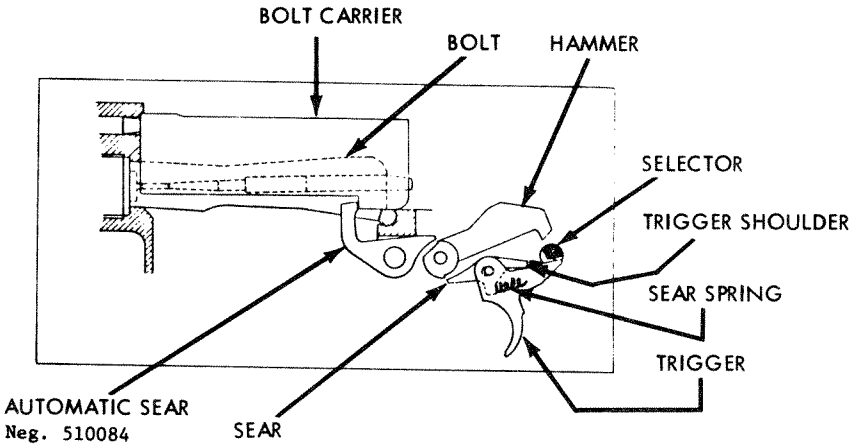

Figure 85. FN/FAL trigger.

f. When the selector is set for semiautomatic fire, the trigger can be moved just enough for the sear (fig 85), which pivots about the trigger pin and is moved by the trigger shoulder, to disengage from the hammer. The hammer swings forward and the sear, under pressure of the sear spring (fig 85), moves forward and upward, against the bottom of the hammer. When the bolt carrier moves forward, the hammer, under the force of the hammer spring, starts to swing forward. The sear snaps into the sear notch of the hammer; this then forces the sear to the rear, against the shoulder, and holds the hammer cocked. To release the hammer, the trigger must be released; the hammer then forces the sear to the rear, over the shoulder. If the trigger is pressed again, it will move to sear to release the hammer.

g. When the selector is set at automatic, the trigger can rotate to its maximum distance, and when it does, the sear is held completely out of engagement with the hammer. The hammer is

then held cocked only by the automatic sear (fig 85). This sear is tripped by the bolt carrier during its last bit of forward travel and releases the hammer to fire another shot. This action, which occurs each time the bolt carrier goes forward, results in automatic fire. The release of the trigger causes the hammer to be caught by the sear in the same manner as in paragraph f above.

h. Two automatic safety features on the rifle prevent firing if the bolt is not locked. This condition will prevent the bolt carrier from going fully forward because its cams will be blocked by the lugs on the bolt. If the bolt carrier is not fully forward, the following will occur:

(1) The automatic sear (fig 85) will not be tripped, and it will continue to hold the hammer cocked, even if the trigger is pressed.

(2) The firing pin will not protrude through the rear wall of the carrier and cannot be struck by the hammer.

i. The bolt stop is held down by a light spring. A rib on the magazine platform contacts the bolt stop when the last round leaves the magazine and the force of the magazine spring lifts the bolt stop up into the path of the bolt. This holds the bolt open when the last round is fired.

131. Accessories

a. Many accessories are made for the FN/FAL rifle. These include several types of bayonets, telescopic sights, infrared night sights, bipods, grenade launchers, and blank firing devices. A complete description of all these would require too much space and is not warranted.

b. Two types of bayonets are in use; one is a conventional type that is slipped over a dovetail on the barrel or flash hider and is removed after a release button is pressed. The other type has a tubular socket handle that slips over the flash suppressor and is held by a spring catch. The catch is pulled away from the socket to remove the bayonet.

c. The grenade launchers are attached and removed like the tubular socket bayonet referred to above. Never insert a bulleted cartridge into the rifle when launching grenades—use only the special blanks. Be sure to rotate the gas plug (para 128i) to prevent damage to the rifle mechanism when launching grenades.

d. Web slings and cleaning rods are usually available for use with the FN/FAL rifle.

D. THE 5.56-MM GALIL RIFLE (ISRAEL)

132. General

a. The 5.56-mm Galil rifle (fig 86) is a standard Israeli Army weapon. This rifle's design is based on the Soviet AK-47, with improvements to meet Israeli requirements. The Galil can be identified by its large rectangular forearm, prominent front sight mount and the gas cylinder, unique bent-up operating handle, and permanently attached bipod.

b. The Galil has several unusual features: the bipod can be used to cut barbed wire or other wire, and the bipod clip in the rear of the hand guard can be used to open soda pop bottles. A fold-away carrying handle is also provided.

c. The Galil is a gas-operated, detachable box-magazine fed, selective-fire shoulder weapon equipped with a folding metal stock. The Galil fires 5.56x45-mm ammunition (sec V).

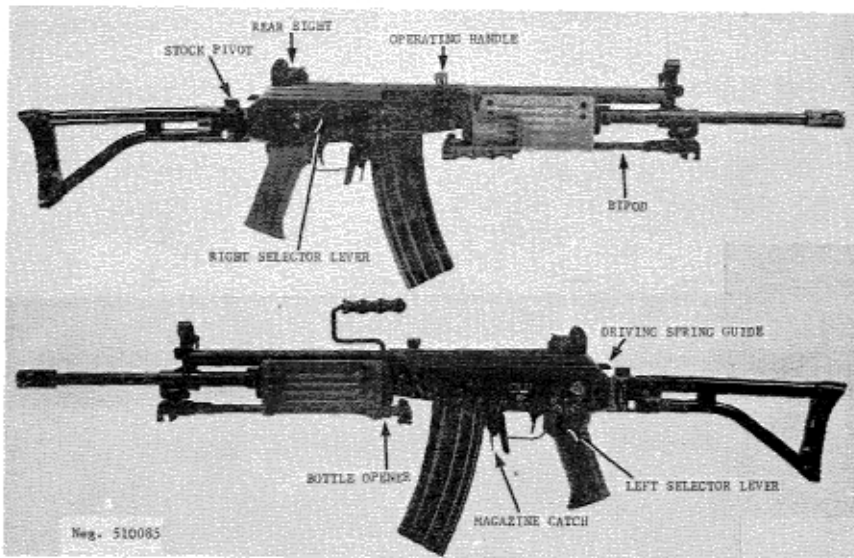

Figure 86. Israeli Galil rifle.

133. Technical Data

Technical data pertaining to the Galil rifle are given in table III.

134. Operation

a. Remove the magazine by pressing the magazine catch (fig 86) forward and then rotating the magazine forward, out of the rifle. Place a 5.56x45-mm cartridge on the magazine follower and press the cartridge down until it rolls sideways, under the feed lip. Repeat until the magazine is full.

b. Unfold the stock by pressing down on the stock pivot (fig 86) until the stock can be swung outward. Rotate the stock rearward until it locks in place. The stock is folded by again pressing down on the stock pivot until it unlocks from the receiver; then swing the stock forward until it locks in place.



Figure 87. Galil on bipod.

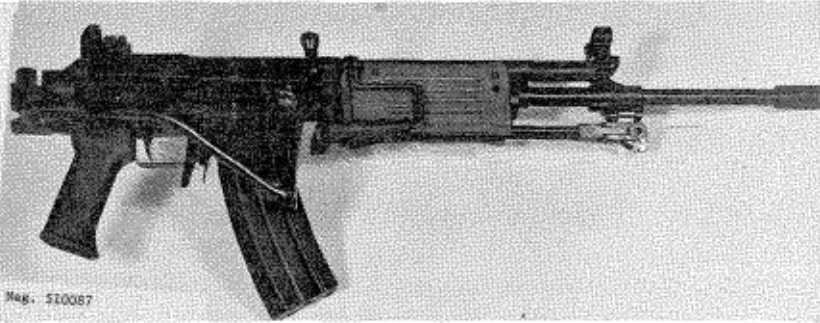

Figure 88. Galil with folded stock.

c. Set the rear sight (fig 86) for range by flipping it forward (300-meter setting) or rearward (500-meter setting). The front sight can be adjusted to zero the rifle. Refer to paragraph 137e for use of night sights.

d. When firing from the prone position, especially at longer ranges, the bipod (fig 87) should be used to steady the rifle. Squeeze the bipod legs together to disengage them from the bottle opener (fig 86), swing them forward, and allow them to spring

open. Fold the bipod by squeezing the legs together, swinging them rearward, and engaging them into the bottle opener. Refer to paragraph 137 for using the bipod to cut barbed wire.

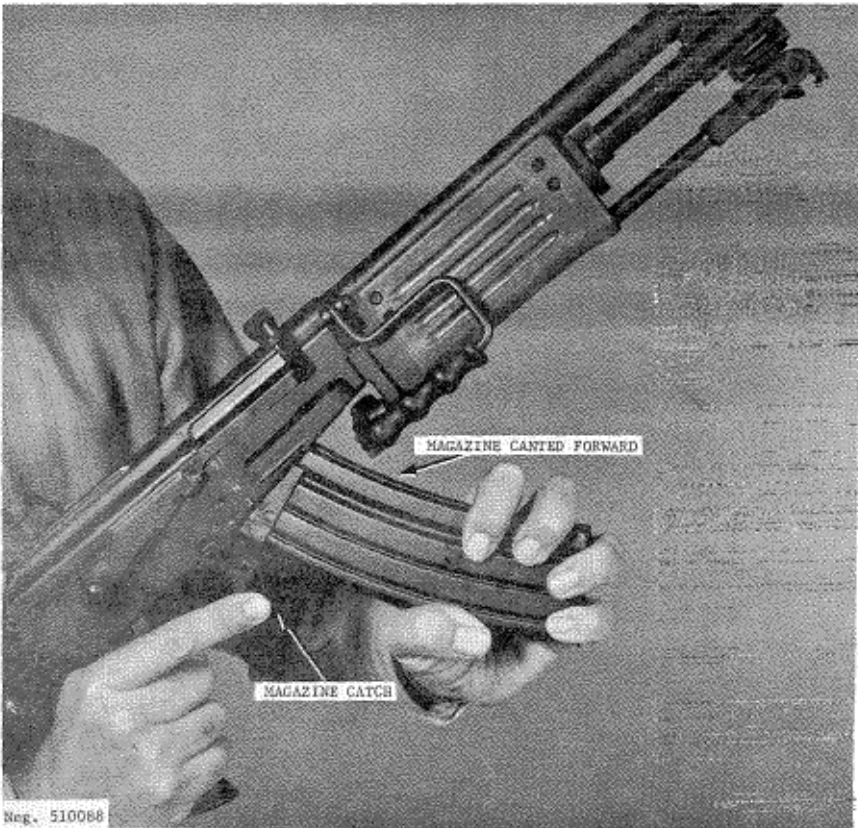

Figure 89. Loading the Galil.

e. To load the Galil, insert a loaded magazine into the magazine well so that the lug on the top front of the magazine engages its recess in the well. (This requires that the magazine be canted forward.) Swing the magazine rearward until the magazine catch (fig 89) snaps into place. Move the selector from safe, if necessary, by pressing the right selector lever (fig 86) down or the

left selector lever (fig 86) rearward. Pull the operating handle (fig 86) fully rearward and release it. CAUTION: The Galil is now loaded and ready to fire! If the rifle is not to be immediately fired, move the right-hand selector up, or the left-hand selector forward, to render the rifle safe.

f. To fire the Galil, move the selector from safe. The mid-position of the selector provides fully automatic fire, the remaining position (down or rearward) provides semiautomatic fire. Aim (using a normal sight picture), and press the trigger; the rifle will fire according to the mode selected. The bolt will remain closed between shots and after the last round has been fired.

g. The Galil may be used to launch 22-mm ID tubed rifle grenades. A special 10-round capacity magazine for holding special (bulletless) grenade launching cartridges is available; however, individual launching cartridges may be directly inserted into the chamber. There are some 22-mm ID tubed grenades that can be launched by a 5.56-mm ball round; however, at present, only bulletless grenade launching cartridges (crimped cartridges) should be used to launch grenades from the Galil, to preclude injury to the firer or the rifle. Remove the magazine, retract the operating handle, insert a grenade launching cartridge into the chamber, release the operating handle, and move the selector(s) to safe. Remove a rifle grenade from its container and slide it over the flash hider (fig 90) as far as possible. If the grenade has a sight leaf packed with it, attach this to the grenade. Remove any safety pins or devices. Aim, using the ogive (largest diameter) of the grenade as a front aiming point, move the selector from safe, and press the trigger. CAUTION: Recoil is severe and some gas may be discharged from the ejection port. It is recommended that rifle grenades be fired only in emergency situations.

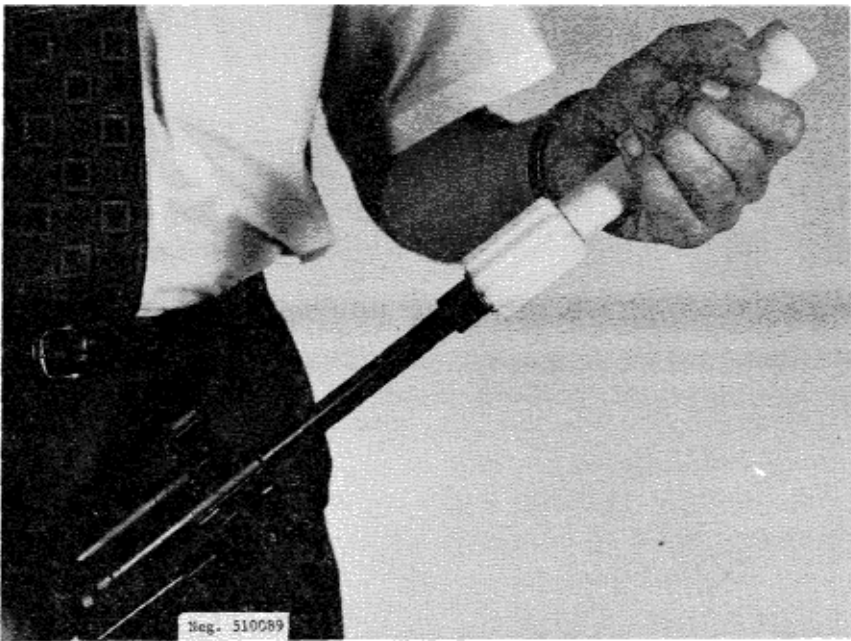

Figure 90. Loading a rifle grenade.

h. To clear or unload the Galil, press the magazine catch forward and rotate the magazine forward, out of the rifle. Insure that the selector is not in the safe position, then pull the operating handle rearward and inspect to insure that no cartridges are present. Release the operating handle, press the trigger to drop the hammer, and move the selector to the safe position. When the selector is at safe, the operating handle can be drawn back just far enough for the rifleman to ascertain if the chamber is loaded or empty. Any cartridges in the magazine can be removed, if desired, by pressing forward, out of the magazine. Insert the empty magazine back into the rifle.

135. Disassembly and Assembly

a. Clear the rifle (para 134h), but do not place the selector on safe or insert the magazine. Press the driving spring guide (fig 86) inward as far as possible, and, while holding it in, pull up the rear end of the receiver cover to disengage it from the receiver. Remove the receiver cover. Press the driving spring guide far enough forward to disengage it from its seat in the receiver. Remove the driving spring assembly.

b. Pull the operating handle fully rearward. Pull the gas cylinder tube (fig 91) to the rear to disengage it from the receiver and gas cylinder. Lift the bolt carrier, with bolt and gas cylinder tube, out of the receiver. (Note: The bolt carrier must be fully to the rear.) Pull the gas cylinder tube off the gas piston. Rotate the bolt in the carrier to disengage the operating lug of the bolt from its cam path in the carrier, then pull the bolt forward, out of the carrier.



Figure 91. Removing gas cylinder tube.

c. No additional disassembly is required or desirable for normal user servicing.

d. To reassemble, insert the bolt into the bolt carrier and rotate the bolt until its operating lug mates with the cam path in the bolt carrier. Slide the gas cylinder tube, large end first, over the piston. Pull the bolt fully forward in the bolt carrier. Place the complete unit (bolt carrier, bolt, and gas cylinder tube) into the receiver so that the guide lugs on the sides of the bolt carrier (fig 91) enter the cutouts at the rear of the receiver. Press the bolt carrier down and slide it forward in the receiver. CAUTION: Be careful not to strike the piston against the gas cylinder. Align the lugs of the gas cylinder tube (fig 91) with their seat in the receiver and slide the gas cylinder tube forward, seating it on the gas cylinder. Push the bolt carrier fully forward.

e. Insert the driving spring into the bolt carrier and force the driving spring guide forward until it can be seated into its recess. Release the guide.

f. Place the receiver cover on the receiver so that the driving spring guide is inside the rear end of the cover. Press the cover forward, insuring that the front end of the cover enters the circular groove in the gas cylinder tube. Press the rear end of the cover down until it seats in the cross groove in the receiver and the driving spring guide protrudes.

136. Functioning

a. The Galil assault rifle is gas operated, i.e., a portion of the gas that propels the bullet through the barrel is tapped off through a port in the barrel and is used to drive the bolt mechanism to the rear during firing. A strong driving spring returns the bolt forward.

b. When the Galil is loaded and cocked, finger pressure on the trigger causes the twin lugs on the top of the trigger (fig 92) to disengage from the hammer; the hammer, under pressure of the hammer spring, swings forward and fires the weapon. The bullet is driven through the barrel by the propellant gases. After the bullet passes the gas port, some of the gases are tapped off and directed against the piston extending from the bolt carrier.

c. The propellant gases drive the piston and the bolt carrier (fig 92) rearward, compressing the driving spring. After one-third inch of free travel, a cam in the bolt carrier contacts the cam stud on the bolt; further travel rotates the bolt 35° and unlocks it from the receiver. The piston, carrier, and bolt all move rearward together, rocking the hammer back. The extractor withdraws the empty cartridge case from the chamber and holds it against the bolt until the case strikes the fixed ejector; the case then pivots around the extractor and is expelled. The bolt carrier hits the inner rear wall of the receiver and stops.

d. The driving spring drives the recoiling parts forward, and, as the bolt moves, its feed rib drives the top cartridge out of the magazine and into the barrel. The extractor snaps into the groove of the cartridge case, and, as the bolt carrier continues forward, its cam rotates the bolt to its locked position. During the final one-third inch of travel, the carrier depresses the automatic sear. The forward movement terminates when the front of the bolt carrier strikes the receiver.

e. The selector or change lever (fig 92) controls the functioning of the trigger mechanism by causing its arm inside the receiver to change positions, in relation to the trigger, as the selector is moved. The safety sear (fig 92), which also holds the hammer cocked, not affected by the selector in any way, is operated solely by the bolt carrier. A projection on the rear of the

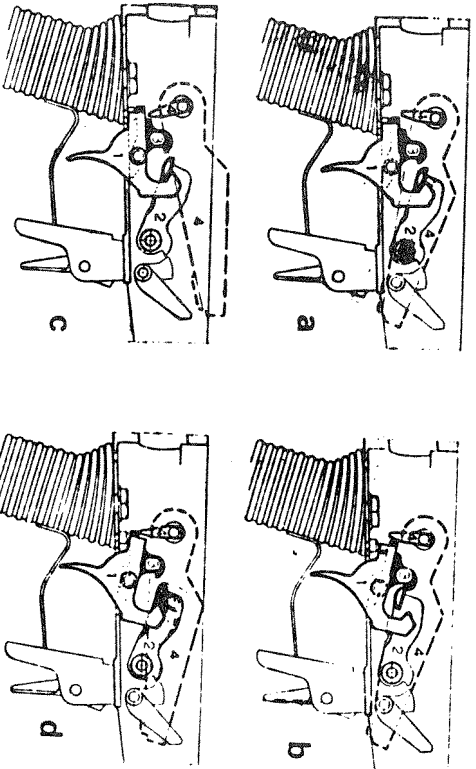

- a. The rifle set on semi-automatic fire, trigger released
 - 1 Trigger
 - 2 Hammer
 - 3 Disconnector
 - 4 Change lever
- b. The rifle set on semi-automatic fire, trigger pulled
- c. The rifle set at safe
- d. The rifle on automatic fire

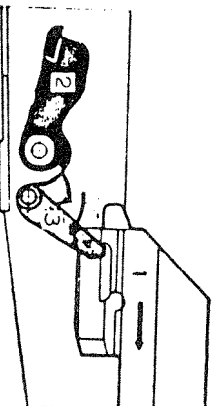
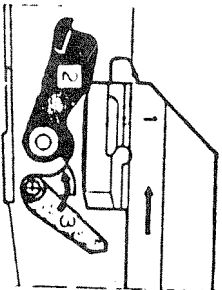

- Bolt carrier moving backwards
 - 1 Bolt carrier
 - 2 Hammer
 - 3 Safety sear

Bolt carrier moving forwards

Neg. 510091

Figure 92. Galil mechanism.

bolt carrier, above the bolt spindle, prevents the hammer from striking the firing pin unless the bolt carrier has moved forward enough to lock the bolt to the receiver.

f. When the selector is in its lowest (semiautomatic) position, the arm of the selector moves to its rearmost position (fig 92) and has no effect on the trigger mechanism. As the trigger is pressed, the twin lugs on the trigger disengage from the hammer, which swings forward. The recoiling bolt carrier rocks the hammer to the rear, and the hammer forces the disconnecter (which, because of the movement of the trigger, has moved forward) to the rear against its spring. As the hammer passes the disconnecter, the sear snaps forward, where it can catch the hammer. Therefore, when the counterrecoiling bolt carrier trips the safety sear, the disconnecter holds the hammer. When the trigger is released, the disconnecter moves rearward and releases the hammer, which is then caught by the twin lugs of the trigger. The trigger must be pressed again to fire another round.

g. By moving the selector to its middle (automatic fire) position, the arm inside the receiver is positioned over the tail of the disconnecter (fig 92). As the trigger is pressed, the disconnecter sear contacts the arm and is rocked rearward; it then cannot catch the hammer. Only the safety sear holds the hammer cocked, and, as the carrier in its final travel depresses the safety sear and releases the hammer, the weapon fires. This action continues as long as the trigger is held depressed and ammunition is present. To stop firing, the trigger is released, and its twin lugs intercept the hammer and hold it cocked.

h. As the selector is moved into its upper (safe) position (fig 92), the arm moves over the rear of the trigger and blocks any trigger movement. If the hammer is uncocked, interference between the hammer and the twin lugs of the locked trigger prevents full retraction of the bolt.

137. Accessories

a. Several different magazines are available for the Galil. These include 35- and 50-round capacity magazines and a special 12-round capacity magazine used only with crimped grenade-launching blank cartridges.

b. The bipod is opened by squeezing its feet together to disengage them from the bottle opener at the lower rear end of the forearm and then swinging the bipod to a right angle to the barrel. When the legs are released, they will now spring apart for use. Fold the bipod by squeezing the legs together, swinging them rearward, and engaging them with the bottle opener. The bipod can be used to cut wire by swinging the bipod forward after the wire is placed in the cutting jaw (fig 93).



Figure 93. Using the Galil to cut wire.

c. The Galil uses a spike-type bayonet (fig 94) similar to that used with the Belgium C.A.L. rifle (para 119b).



Figure 94. Galil bayonet.

d. To use the bottle opener (fig 95), disengage the bipod legs from it and place one edge of the bottle cap under one side of the opener. Lever the bottle against the other side, and the cap will pop off.

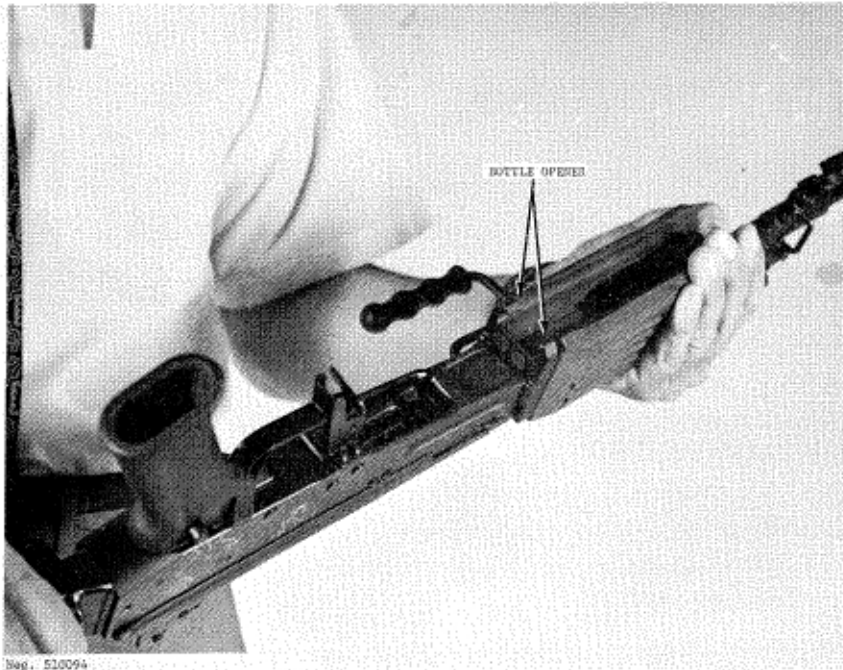

Figure 95. Galil bottle opener.

e. The Galil has auxiliary luminous night sights (fig 96). Flip these sights up for use at ranges to 100 meters at night and flip them down for daytime use of the normal sights.

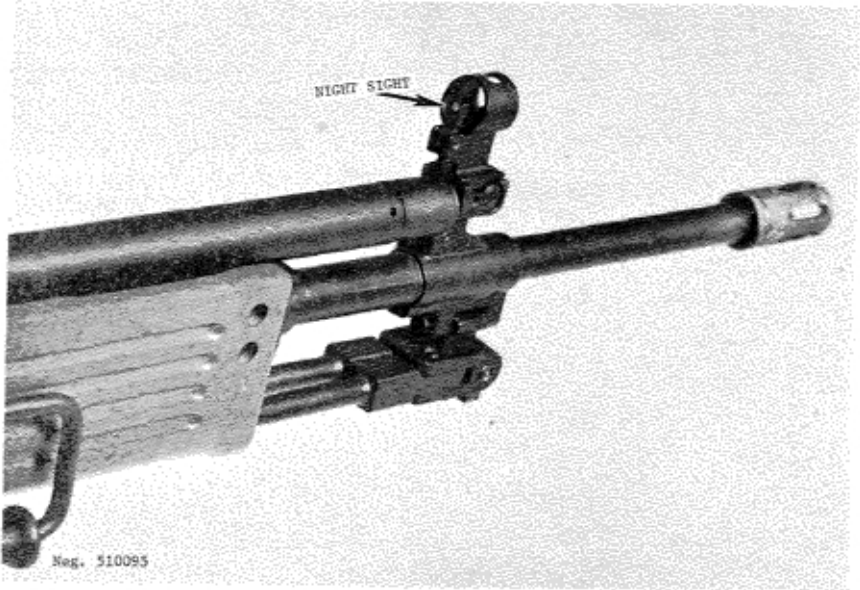

Figure 96. Galil front night sight.

E. THE 5.56-MM BERETTA M70/.223 RIFLE (ITALY)

138. General

a. The 5.56-mm Beretta M70/.223 rifle is the most recent military rifle developed by the Beretta firm of Italy. The M70/.223 is made as a conventionally stocked rifle (fig 97), as a folding-stock rifle (fig 98), and as a light machinegun (fig 99). All of these variant weapons use the same mechanism and magazine; the differences lay in the different type stocks used and in the heavy barrel and bipod of the machinegun.



Figure 97. Italian Beretta M70/.223 rifle.

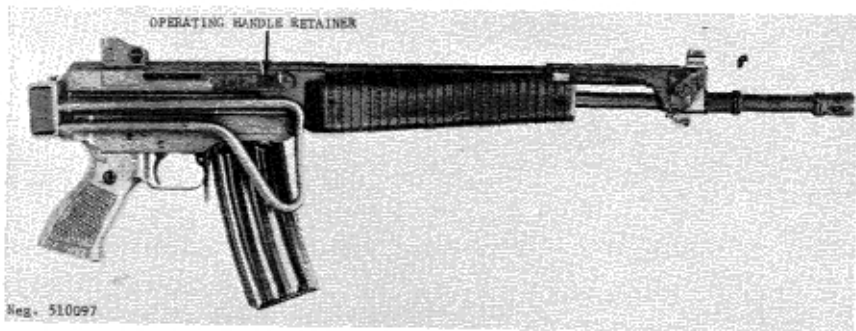

Figure 98. Beretta M70/.223 rifle with folding stock (early model).

b. No army has yet adopted the M70/.223, but this weapon is offered for sale throughout the free world and probably will be adopted by several nations.



Figure 99. Beretta M70/.223 automatic rifle (LM).

c. The Beretta M70/.223 is a gas-operated, detachable box-magazine fed, selective-fire shoulder weapon. It is fitted with a combination flash hider/grenade launcher and integral grenade launching sights. These sights, when erected for launching grenades, automatically cut off the rifle's gas mechanism.

d. The Beretta M70/.223 rifles fire 5.56x45-mm cartridges (refer to sec V).

139. Technical Data

Technical data pertaining to the Beretta M70/.223 are given in table V.

140. Operation

a. Load the magazine by placing a cartridge on the follower and pressing it down until it rolls sideways under a feed lip; repeat until the magazine is full. Insert the loaded magazine straight into the rifle until the magazine catch snaps into place and retains the magazine.

b. Grasp the operating handle (fig 97), pull it fully rearward, and release it. CAUTION: The rifle is now loaded and ready to fire. If the rifle is not to be immediately fired, place it on safe by rotating the selector (fig 97) to the vertical position, indicated by the letter "S".

c. To fire, rotate the selector to the position for the desired type of fire—rearward to 1 for semiautomatic fire, forward to A for automatic fire. Adjust the rear sight for the desired range, aim (using a normal sight picture), and press the trigger. If the selector has been set to 1, the rifle will fire one shot and reload itself; if set to A, it will fire as long as the trigger is pressed and cartridges are in the magazine. The bolt will remain closed between rounds and will remain caught rearward when the last round in the magazine has been fired.

d. Remove the empty magazine by pressing the magazine catch (fig 97) toward the magazine and pulling the magazine out of the rifle. The bolt can be closed either by pulling the operating handle rearward and releasing it or by pressing in the top of the bolt catch (fig 97) inward.

e. To clear the rifle, set the selector (fig 97) to the safe (vertical) position "S". Press the magazine catch toward the magazine and pull the magazine out of the rifle. Press in the bottom of the bolt catch (fig 97) and, while holding it in, pull the operating handle fully rearward and release it. The bolt will be caught open. Inspect to insure that no cartridges are present. Press in the top of the bolt catch, rotate the selector off safe, and press the trigger. Insert the magazine.

f. To launch grenades, set the rifle on safe after loading (a above). Ball cartridges can be used only if MECAR brand 22-mm tube rifle grenades with bullet traps are available. The grenades are

marked on the tail boom if a bullet trap is incorporated. If it is not positively known that the grenade has a bullet trap, clear the rifle and insert a bulletless, crimped grenade cartridge into the chamber. Slide a grenade over the grenade launcher and seat it fully. Erect the front and rear grenade sights (fig 97). (Note: The front sight is only an indicator that the gas mechanism has been turned off to protect the rifle's mechanism.) Aim, using the appropriate 50-, 75-, or 100-meter aperture in the rear grenade sight and the regular front sight post, and press the trigger. Pull the operating handle rearward to eject the fired cartridge case.

141. Disassembly and Assembly

a. Clear the rifle (without moving the safety off safe), press the trigger, or insert the magazine. Press out the takedown pin (fig 97) from left to right and swing open the receiver (fig 100). Pull the operating handle retainer (fig 98) to the rear with the point of a bullet and pull out the operating handle. Hold a hand behind the receiver opening and point the muzzle upward; the bolt unit will emerge from the rear of the receiver. If necessary, partially engage the operating handle with its hole in the bolt carrier and pull the bolt unit to the rear until it can be removed. Pull the bolt (fig 100) forward in the carrier (fig 100), twisting the bolt at the same time until it comes out of the carrier.

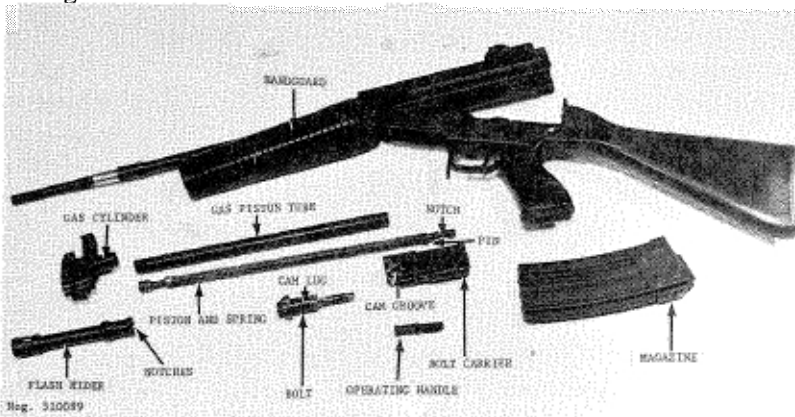

Figure 100. Beretta M70/.223 disassembled.

b. In the front of the gas cylinder is a small plunger that seats in the notches of the flash hider (fig 100). Push the plunger in and unscrew the flash hider (right-hand thread). Pull the gas cylinder (fig 100) forward, off the barrel, and pull the gas piston tube (fig 100) forward and remove it. Push the piston (fig 100) rearward slightly, against the pressure of its spring, until the piston can be rotated. Ease the piston forward, then rotate it until it comes free.

c. The handguard (fig 100) can be removed by pulling down on its front end until it comes off the barrel. Rotate the handguard down until it can be removed.

d. No further disassembly is necessary or desirable.

e. To reassemble, engage the hook at the rear of the handguard with its crosspin in the lower front of the receiver and swing the handguard up until it can be snapped onto the gas piston tube.

f. Insert the piston into the receiver. The small pin (fig 100) must be aligned with its slot in order to enter the receiver. Once in the receiver, rotate the piston so that the notch for the operating handle (fig 100) faces down and the pin seats in its recess to prevent rotation of the piston. Slip the piston tube over the piston and seat it in the receiver.

g. Slide the gas cylinder on over the barrel and fit the front end of the piston tube into the gas cylinder. Seat the gas cylinder fully against its shoulder on the barrel. Screw the flash hider onto the barrel; it is necessary to depress the lock plunger to screw the flash hider fully in place. Release the lock and rotate the gas cylinder until the lock seats in one of the notches.

h. Insert the bolt spindle into the hole in the bolt carrier and seat the bolt in the carrier. Twist the bolt while seating it to insure that the operating lug on the bolt mates with the cam recess in the bolt carrier. Pull the bolt forward in the carrier until the bolt stops.

i. Insert the bolt carrier into the receiver, bolt first, and move it fully forward. Insert the operating handle into its hole in the bolt carrier (forcing the retainer rearward) until the retainer snaps into place. Pull the operating handle rearward to insure that it has engaged the piston, and spring pressure is felt. Close the receiver, push the takedown pin (fig 97) home, move the safety off safe, press the trigger, and insert the magazine.

142. Functioning

a. The Beretta M70/.223 is gas operated. When the rifle is loaded and cocked, pressure on the trigger releases the hammer which, under pressure of its spring, swings forward, strikes the firing pin, and fires the chambered cartridge. As the bullet drives down the barrel, it passes the gas port and some propellant gases are diverted through the port into the gas cylinder. The gas piston (fig 101) is driven rearward, driving the bolt carrier rearward, and compressing the driving spring.

b. As the bolt carrier moves rearward, it causes the hammer to rock back, and the safety sear (fig 101) rises. As the bolt carrier continues rearward, the cam recess in the carrier (fig 101) acts on the operating lug of the bolt and rotates the bolt to its unlocked position. Once unlocked, the bolt and carrier move to the rear as a unit. The extractor pulls the fired cartridge case from the chamber and holds it to the bolt until the case strikes the ejector and is expelled through the ejection port. The bolt carrier finally strikes the rear of the receiver and stops. The driving spring then drives the bolt carrier forward, and the feed rib on the bolt

drives the top cartridge out of the magazine and into the barrel. The bolt strikes the barrel and stops; the bolt carrier continues forward, rotates the bolt to its locked position, and trips the safety sear. The extractor snaps into the cartridge groove.

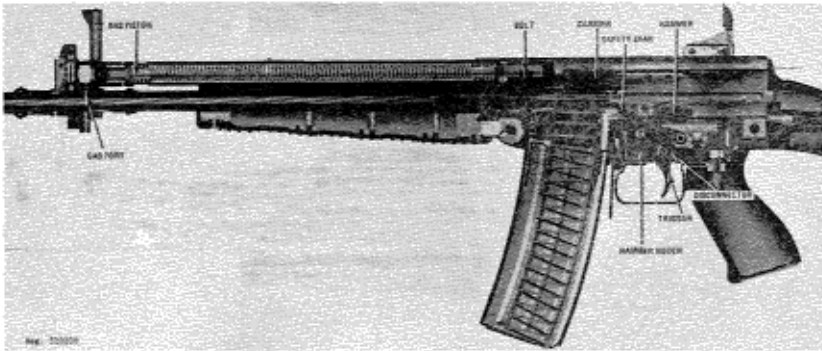

Figure 101. Beretta M70/.223 section.

c. When the selector is set on I (semiautomatic), the hammer is held cocked by the nose of the trigger engaging a notch in the hammer; when the trigger is pressed, it disengages from the hammer, allowing it to swing forward. As the trigger rotates, the disconnecter (fig 101) rotates with it, and the disconnecter hook moves forward to where it can engage a second notch on the hammer (fig 101). When the bolt carrier counterrecoils, the disconnecter then catches the hammer and holds it cocked. When the trigger is released, the disconnecter rotates rearward with it and releases the hammer; the trigger, however, has moved enough so that the trigger nose reengages the hammer. Pressure on the trigger will now fire a second shot.

d. When the selector is set at A (automatic), a portion of the selector swings off the rear of the disconnecter (fig 101) so that when the trigger is pressed the disconnecter is blocked and does not move with the trigger as in paragraph c above. When the

3 February 1984

bolt carrier counterrecoils, only the safety sear (fig 101) holds the hammer cocked, and as the bolt carrier completes its forward travel, it trips the safety sear which releases the hammer to fire another round. This action continues until the magazine is empty, or until the trigger is released and its nose engages the hammer.

e. When the selector is set at safe, a portion moves over the rear of the trigger and prevents it from being pressed sufficiently to release the hammer.

f. When the magazine is empty, the magazine follower contacts the bolt catch and, because the strong magazine spring overcomes the weaker bolt catch spring, moves the bolt catch to where it can intercept the bolt. Thus, the bolt and carrier are held open when the last round is fired.

143. Accessories

a. The Beretta M70/.223 has the usual rifle accessories (extra magazines, web sling, bayonet, and telescopic sight).

b. The bayonet (fig 102) is affixed by slipping its loop over the flash hider engaging the T slot in the bayonet hilt with the lug under the gas cylinder. Press the bayonet on until the locks engage. To remove the bayonet, press the locks and pull the bayonet forward, off the rifle.

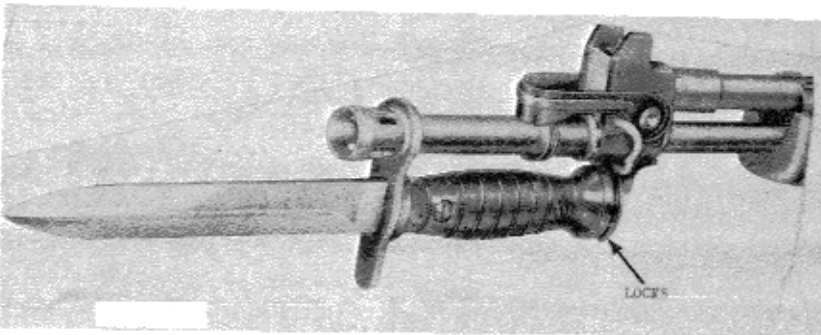

Neg. 510101

Figure 102. Beretta M70/.223 Bayonet

3 February 1984

c. Mounting pads are necessary to install the telescopic sight on the receiver. These pads are factory installed. To mount the telescope, fit it over the pads with the lock lever (fig 103) rearward. When the telescope is seated, swing the lever forward to lock the telescope in place. Reverse to remove the telescope.

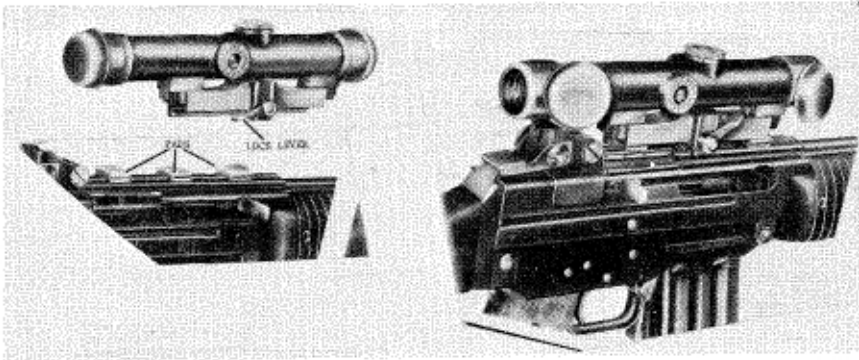

Neg. 510102

Figure 103. Beretta M70/.223 Telescopic Sight.

d. The telescopic sight is adjusted as described in paragraph 91d. Close the non-aiming eye when using the Beretta telescope.

E.1. THE 5.56-MM AUG (St.G.) RIFLE (AUSTRIA)

143.1. General

a. The 5.56-mm AUG (Armee-Universal-Gewehr) or Army Universal Rifle (fig 103.1) is the latest standard rifle of the Austrian Army. It is manufactured by the world-famous Steyr-Daimler-Puch factory and comes in three versions. There is a short-barreled (407-mm) carbine version, a medium-length-(508-mm)-barreled rifle, and a long-barreled (610-mm) light machinegun version. The AUG can be easily recognized by its unique shape and by the extensive use of plastics in its construction. All parts are plastic with the exception of the steel barrel, bolt and pins, and springs and the aluminum and steel receiver.



Neg. 529275

Figure 103.1. Austrian 5.56-mm St.G 77 (AUG) assault rifle with 508-mm barrel.

b. The St.G 77 (AUG) cannot be equipped with any type of folding stock, because its breech mechanism operates within the buttstock. In order to provide shorter than normal weapons, various barrel lengths are available; the shortest of these, when installed, provides a rifle as short as any with a folding stock.

c. The major sighting equipment is a 1.5 power optical sight. The reticle of this sight is in a ring suspended in the middle of the telescope. A small blade-type foresight and "v" notch rear sight are formed into the telescope body top surface for emergency use. An adjustable gas regulator permits varying the operating power when the rifle is fouled; it also, by setting the regulator to an "off" position, permits the launch of 22-mm tube rifle grenade by using the flash suppressor as a grenade launcher.

d. The St.G 77 (AUG) fires 5.56x45-mm ammunition. The clear plastic magazines permit the ammunition status to be determined at a glance. Full or semiautomatic fire is determined by how hard the trigger is pressed.

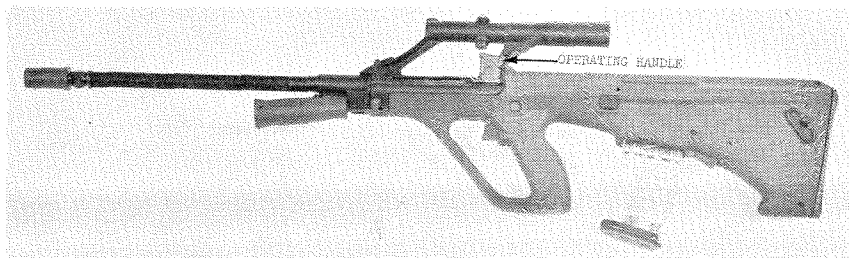

Neg. 539274

Figure 103.2. Austrian St.G 77 (AUG) with 610-mm barrel. Operating handle locked to rear.

143.2. Technical Data

Technical data pertaining to the St.G 77 (AUG) rifle are presented in Table V.

143.3. Operation

a. Load the magazine by placing a cartridge on the follower and pressing it down until it rolls sideways under a feedlip. Repeat until the magazine is full.

b. Insert a loaded magazine into the magazine opening until the magazine catch (fig 103.3) snaps into place and retains the magazine. Grasp the operating handle (fig 103.3), pull it fully rearward, and release it. It will fly forward, along with the bolt mechanism, and load the rifle. (CAUTION: The rifle is now loaded and ready to fire.) Should the bolt fail to fully close, pull the operating handle as far rearward as possible and, while holding the bolt engagement button (fig 103.3) inward, force the operating handle fully home.

174.3

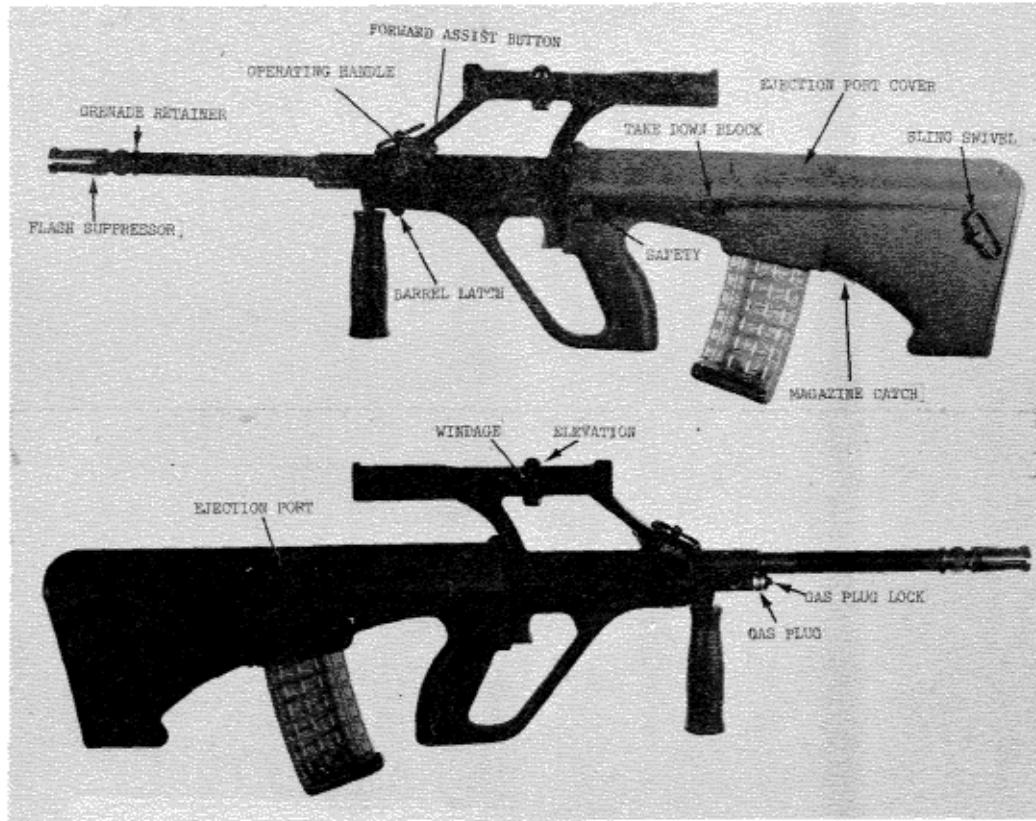

Neg. 529273

Figure 103.3. St.G 77 (AUG) controls.

c. If it is not desired to immediately fire the rifle, press the safety catch (fig 103.3) to the right. The foregrip can be placed in either up or a down position (fig 103.1 and 103.3); to do this, pull the grip away from the receiver against the force of its spring, then move the grip to whatever position is desired.

d. To fire: Press the safety catch (fig 103.3) to the left, aim, (see subpara 3 below) and press the trigger. Light pressure on the trigger will fire one shot and the rifle will reload itself. Heavy pressure on the trigger will result in automatic fire (Note: Newly manufactured rifles require a deliberate heavy pull to achieve full automatic fire). When the last round in the magazine has been fired, the bolt mechanism will be held to the rear. Remove the empty magazine by grasping it, then pressing the magazine catch (fig 103.3) and withdrawing the magazine. The breech mechanism may be released by pulling the operating handle fully rearward and then releasing it.

e. To aim (using the telescope sight), the circular reticle, visible in the center of the field of view when looking through the telescope, should be aligned over the area of the target it is desired to hit before pressing the trigger. The telescope can be zeroed to the rifle by turning the adjustment screw as necessary (fig 103.3) on the side (windage) and top (elevation) of the telescope. Do not remove the bottom cap on the telescope sight. Should the telescope sight be unserviceable, use the emergency sights formed on top of the telescope sight reticle (fig 103.3). Use a sight picture similar to that of the US caliber .45 Pistol M1911A1.

f. To clear the rifle, first remove the magazine by pressing the magazine catch (fig 103.3), then withdraw the magazine. Grasp the operating handle, pull it fully to the rear, then rotate it upward into its rear retaining notch (fig 103.3). Inspect to insure that no cartridges are present in the barrel or mechanism, then rotate the operating handle downward, out of the retaining notch, and release it. Press the trigger and reinsert the magazine.



Neg. 529277

Figure 103.4. Barrel removal.

g. There are three different lengths of barrels available (refer to para 143.6). To change barrels, clear the weapon (f above) but do not release the operating handle from its rearmost position. Move the foregrip to its vertical position. Press the barrel latch (fig 103.4), rotate the barrel (by means of the foregrip) clockwise, until the barrel disengages, and then slide the barrel forward out of the receiver. Insert the replacement barrel into the receiver, slide it fully rearward, and rotate it counterclockwise until the barrel latch snaps into place. Release the operating handle.



Neg. 529279

Figure 103.5. Barrel removed.

h. The gas plug (fig 103.3) is adjustable. Normally the small dot on the plug is aligned with the index on the gas cylinder (fig 103.3). If the rifle becomes very foul and fails to reload itself during firing, the gas plug should be adjusted to increase operating power. Use a bullet point to press the spring-loaded plug lock (fig 103.3) out of engagement with the gas cylinder; then rotate the plug until the large dot aligns with the index on the gas cylinder.

i. Should it become necessary to launch rifle grenades from the St.G 77 (AUG), disengage the plug lock as described in the preceding paragraph and rotate the plug 180° to cut off the gas supply to the rifle mechanism. Slide the 22-mm tail-boom-tubed grenade over the flash suppressor (fig 103.3)

as required. The retainer spring (fig 103.3) will hold the grenade in place. CAUTION: Observe all precautions applicable to the particular type/make of grenade used, especially as to the type of cartridge used to launch the grenade. Never, repeat never, use a ball cartridge to launch a grenade (unless the use of a ball cartridge is authorized by the manufacturer of the grenade being launched); use only the special grenade launching cartridge.

143.4. Disassembly and Assembly

a. Clear the weapon by pressing the magazine catch and withdrawing the magazine; then pull the operating handle fully to the rear and rotate it upward (fig 103.3) into its retaining notch. Inspect to insure that no cartridges are present.

b. Press the barrel lock (fig 103.4) down and rearward. While holding the lock, rotate the barrel clockwise as far as possible; then pull the barrel straight out to the front. Note: the bolt must be retracted before removing the barrel.



Neg. 529278

Figure 103.6. Separation of receiver from stock.

c. Press the takedown block (fig 103.3 and 103.5) fully to the right; then pull the receiver forward, out of the stock (fig 103.6). The bolt assembly may or may not come out with the receiver. If it does, pull it rearward out of the receiver. If it remains in the stock, pull it forward, out of the stock (fig 103.7).

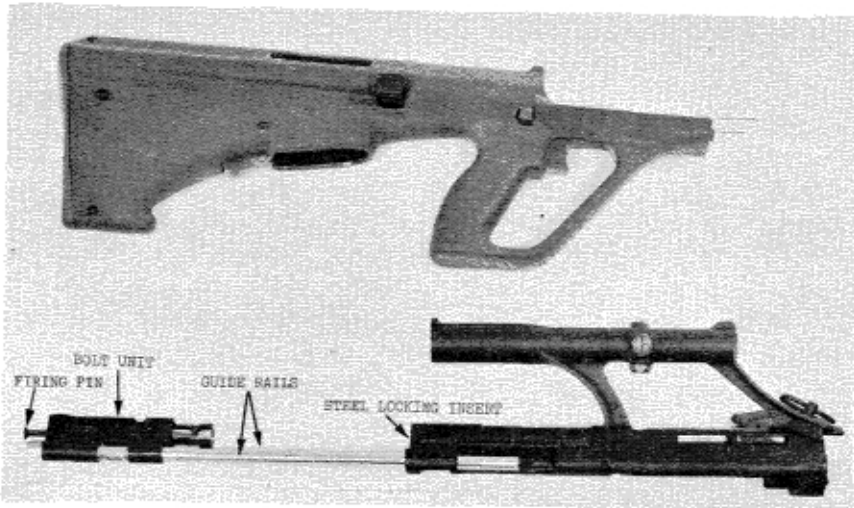

Neg. 529280

Figure 103.7. Removal of bolt mechanism from receiver.

d. Grasp the firing pin (fig 103.7), pull it rearward; then twist it counterclockwise one quarter turn. This will free the firing pin so that it can be withdrawn rearward. Turn the bolt unit over and insert the firing pin point in the large hole in the bolt carrier. Press the pin in until it forces the locking cam pin (fig 103.8) out of the bolt and bolt carrier. CAUTION: Press straight in on the firing pin; do not apply any side force; to do so can break the firing pin. Remove the firing pin. Pull the bolt, bolt guide, bolt guide spring, and bolt guide spring plunger forward out of the bolt carrier

(fig 103.8). The bolt carrier plug (fig 103.8) can be pulled free of the carrier if it does not fall free. Separate the bolt from the bolt guide. If necessary, remove the extractor by using the firing pin point to press out the extractor pin. **CAUTION:** Be careful not to lose the small pin or the spring with its plastic insert.

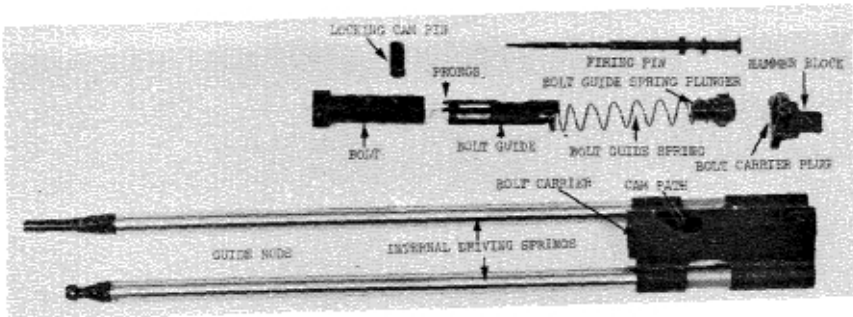

Neg. 529283

Figure 103.8. Bolt unit disassembled.

e. Reassemble the bolt by placing the extractor in its recess and pressing it down until the holes in the bolt align with those in the extractor. Press the extractor pin back into place. Place the bolt in the bolt guide so that the right hand projection on the bolt guide is between the bright lug on the extractor and the locking lug to its immediate left, and insuring that the cam pin hole in the bolt is not blocked by the bolt guide. Align the bolt guide spring plunger with the hole in the bolt carrier and slide the unit about half way back into the carrier. Slide the bolt carrier plug into its seat; then press the bolt and its guide fully into the bolt carrier against spring pressure until the cam pin can be inserted into the bolt. Note: If the cam pin cannot be inserted, pull the bolt forward out of the engagement with its guide, and rotate the bolt until the end of the cam pin hole without the stake mark can be seen. Reinsert the bolt and cam

pin. Turn the cam pin until the line inscribed on its end is aligned with the bolt unit. Insert the firing pin into the bolt carrier plug so that the lugs and the pin enter the plug. Press the firing pin fully home; it will automatically rotate and lock in place. Slide the two guide rods into the tunnels in the receiver.

f. Firmly press in on the recess in the butt plate (fig 103.9) and, while pressing, press the rear sling swivel toward the stock. This frees the butt plate, which now can be recovered. The cleaning kit (fig 103.10) is contained under a removable cover in the bottom of the butt. The hammer mechanism housing (fig 103.10) can be removed for cleaning. Press in on the extension (fig 103.10) and, while holding it in, pull the rear sling swivel and pin out of the stock. The hammer mechanism housing can now be slid out of the stock.

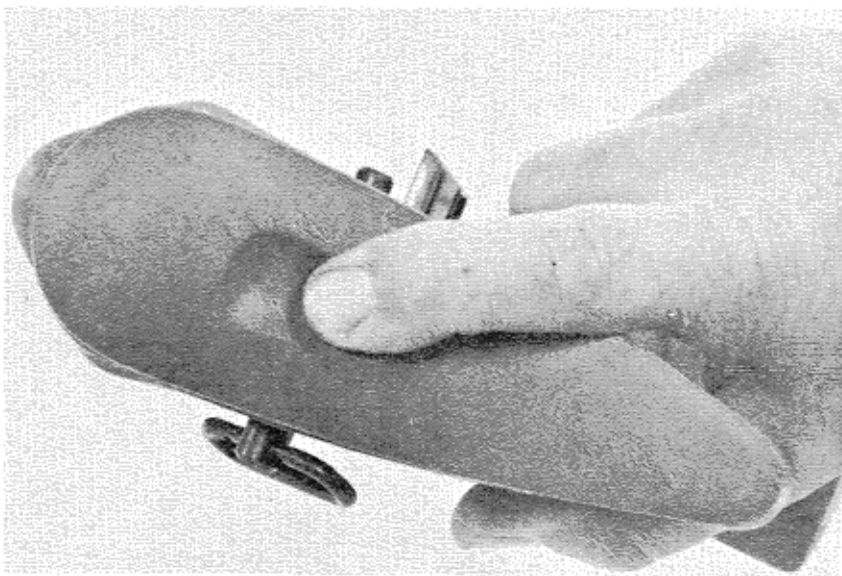

Neg. 529284

Figure 103.9. Releasing rear sling swivel.

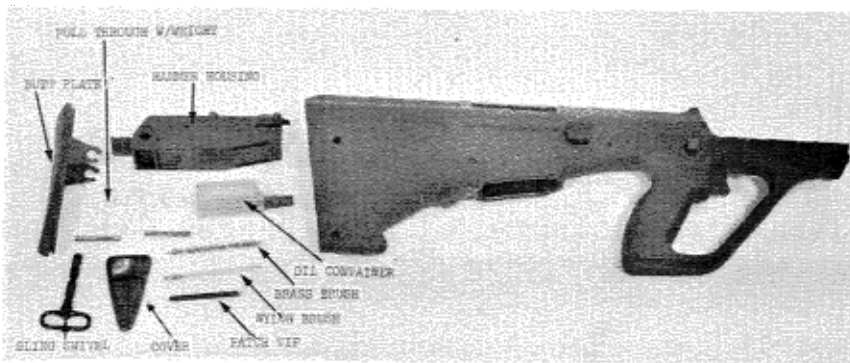

Neg. 529282

Figure 103.10. Stock unit disassembled.

g. No further disassembly is necessary or advisable.

h. Cock the hammer and insert the hammer mechanism into the stock, hammer end first. Press in the extension and reinsert the rear sling swivel and pin. Insure that the swivel is fully against the side of the stock. The swivel normally should be inserted from right to left; however, if desired, it can be inserted in the opposite way. Engage the bottom of the buttplate (fig 103.10) into the bottom of the stock; press the buttplate into place; then pull the swivel away from the stock.

i. Insure that the takedown block (fig 103.7) is fully to the right; then insert the receiver and bolt into the stock. When the receiver is fully in, press the takedown block fully into the stock.

j. Insert the barrel into the receiver, pressing it rearward against the force of the barrel lock. Rotate the barrel until it is locked in place.

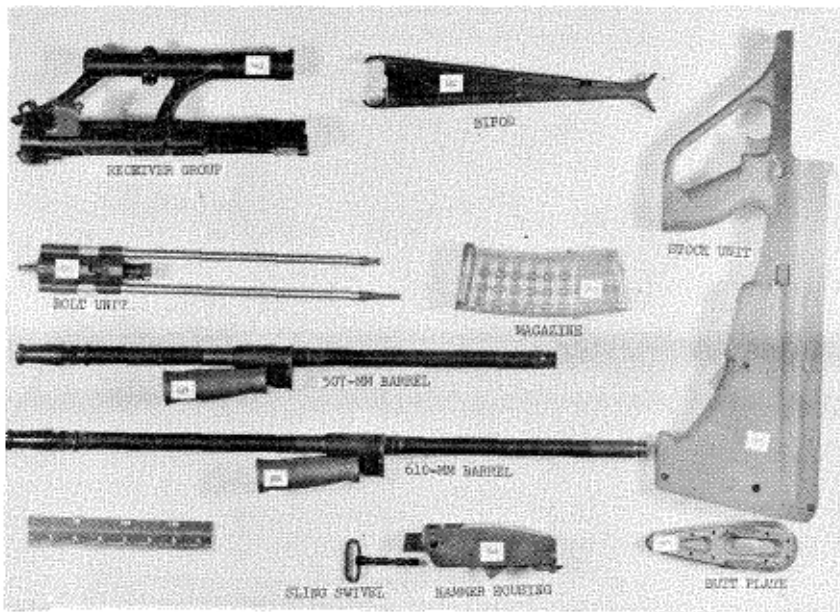

Neg. 529281

Figure 103.11. St.G 77 (AUG) field stripped.

143.5. Functioning

a. The AUG rifle is gas operated. Upon firing, when the bullet passes the gas port in the barrel, some of the propellant gases are diverted through the port into the gas plug through one of the two ports in the plug. The gases then act upon the piston, driving it rearward and compressing the piston return spring. Excess gas is vented from one of the two different sizes of ports in the gas plug. The rearward movement of the piston is transmitted to the right rod of the bolt carrier (fig 103.12), driving the bolt carrier rearward. The multiple lugs on the bolt are locked to their mating lugs in the receiver, but as the bolt carrier moves rearward the cam pin, acted on by the cam path in the bolt carrier, rotates the bolt to unlock it from the receiver (fig 103.12). The bolt guide, thrust

forward by its spring, places its prongs (fig 103.8) between the top locking lugs of the bolt as the bolt clears the receiver. This action prevents the bolt from rotation in relation to the bolt carrier, and also holds the bolt extended for reloading. A small fore and aft motion of the bolt, resisted by the bolt guide spring, buffers the bolt when it intercepts the top round in the magazine when feeding.

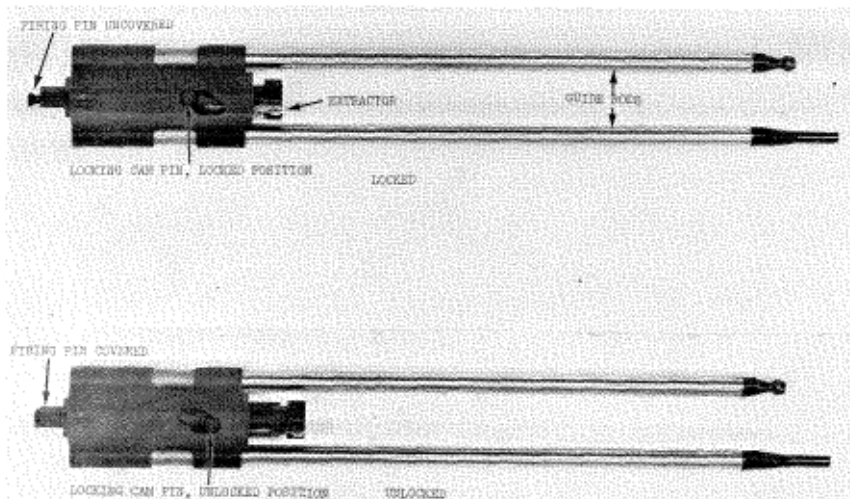

Neg. 529271

Figure 103.12. Bolt functioning.

b. The spring-loaded extractor withdraws the fired cartridge case from the chamber. When the front of the case clears the front edge of the ejection port, the spring-loaded, plunger-type ejector causes the case to pivot about the extractor and be expelled from the rifle.

c. The driving spring in the guide rods of the bolt carrier (fig 103.8) is compressed during the rearward movement by fixed push rods attached to the inside of the stock. As the bolt carrier moves rearward, it allows the automatic sear (fig 103.13) to

move rearward, and then the bolt carrier rocks the hammer back, compressing the hammer spring. After the hammer rotates sufficiently rearward, the automatic sear snaps into engagement with the hammer. The rearward movement stops when the bolt carrier strikes the buffers that surround the push rods inside the stock.

d. The driving springs now drive the bolt and bolt carrier forward. The bolt strikes the top round in the magazine and drives the round out of the magazine and into the barrel. The bolt guide strikes the locking lug plate on the end of the receiver and ceases forward movement. As the bolt continues forward, the prongs on the bolt guide move from between the bolt locking lugs and release the bolt. The ejector is compressed, and the bolt carrier acts on the cam pin; this action rotates the bolt into its locked position with the receiver. The automatic sear is tripped to release the hammer in the last bit of bolt carrier travel in the receiver. If for some reason the bolt does not fully lock, a projection on the bolt carrier plug (fig 103.12) prevents the hammer from striking the firing pin.

e. The trigger is a two-stage trigger. The first part of the pull will cause semiautomatic fire. The trigger will come to a definite stop. If pressed beyond the stop, fully automatic fire will result.

f. When the trigger is pressed to fire the first round, the automatic sear has disengaged the hammer, which is then held cocked by the rear sear engagement of the rear hammer lug (fig 103.13). As the trigger is pressed, rods that extend rearward from the trigger pass each side of the magazine and enter the hammer housing and force the sear unit rearward. The rear sear releases the hammer, which,

under the force of its tension spring, swings forward and strikes the firing pin, driving it against the cartridge primer, firing the round.

g. The hammer is rocked back by the recoiling bolt carrier (h above), and, as it strikes the front sear (fig 103.13), it forces this sear forward against a light spring. As the hammer continues to rotate rearward, it passes the front sear, which swings back into position to engage the front of the hammer lug. This engagement occurs when the automatic sear is tripped by the bolt carrier just before it completes its forward movement. To fire another shot, the trigger must be released; this allows the sear spring to drive the sear unit and trigger forward. As the sear unit moves forward, the front sear releases the hammer, and, under pressure of its spring, the hammer swings slightly forward until it is caught by the rear sear. Pressure on the trigger will now fire another shot.

h. In semiautomatic fire, the rear movement of the sear unit is stopped by projections on each inner side of the hammer box. By increasing the pressure on the trigger, the rear sear overrides the stop projections and moves somewhat further rearward after releasing the hammer. During the increased travel, a lug on the front sear engages a crosspin in the hammer box. As this occurs, the front sear is rotated forward, where it cannot engage the hammer. At this point, only the automatic sear (fig 103.13) holds the hammer cocked, and, when this sear is tripped by the bolt carrier, the hammer is released to fire another shot. This action continues until the trigger is released and the rear sear engages the hammer to hold it cocked.

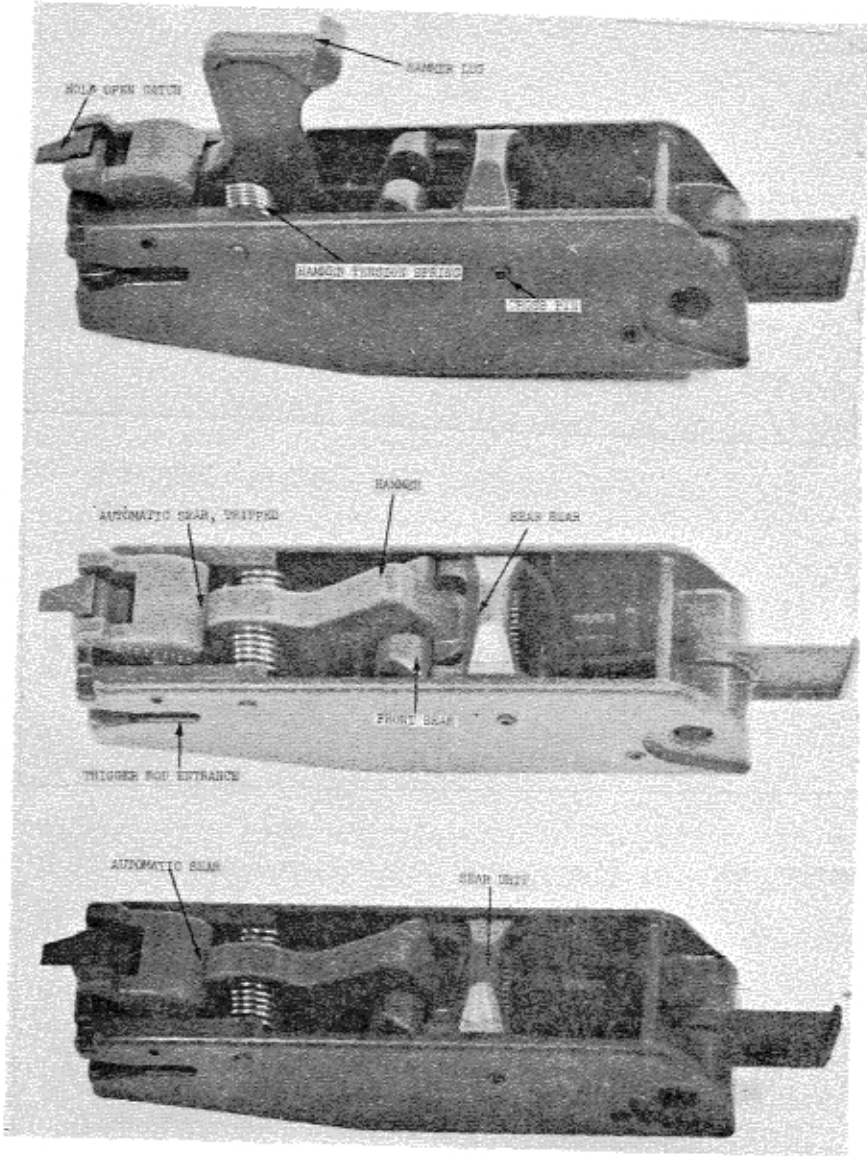

Neg. 529272

Figure 103.13. Hammer housing functioning.

i. When the last round is fed from the magazine, a projection on the magazine follower engages the hold open catch on the front of the hammer box (fig 130.13). The strong follower spring overcomes the weaker spring that holds the hold open catch depressed. The catch then rises when the bolt recoils, and, as the bolt starts to counterrecoil, catches the bolt and holds it to the rear.

143.6. Accessories

a. The St.G 77 (AUG) has a number of accessories available. These include three interchangeable barrels: 407 mm (16 in), 508 mm (20 in) and 610 mm (24 in) long. Each barrel is complete with its flash suppressor/grenade launcher, gas cylinder, and gas plug. A quick attachable bipod, a bayonet, and a blank fire device are also available. Besides the integral optical sight, night vision sights are also available.

b. Each rifle carries a cleaning kit under the buttplate (refer to para 143.4f). This kit includes a plastic oil container, a "pull-through" cord with two weights, a brass bore brush, a nylon bore brush, and a slotted tip for cleaning patches. To use the pull-through, screw one of the brushes or the patch tip onto one of the weights; then, with the breach mechanism held open (by inserting an empty magazine and pulling the operating handle fully rearward), drop the other weight into the chamber. By tilting the muzzle downward, the weight will pass through the barrel and emerge from the muzzle. Using the weight as a handle, pull the other weight with attachment through the bore. CAUTION: Insure that the cord is not frayed and do not use excessive force to pull the patch through the barrel. If the cord breaks, the rifle cannot be used without major repairs.

F. THE 7.62-MM G3 RIFLE (WEST GERMANY, ETC.)

144. General

a. The 7.62-mm G3 rifle (fig 104 and 105) is a standard weapon in the West German, Portuguese, Swedish, Burmese, Nigerian, and other armies, and also is produced for commercial sale. The G3 is a development of the Spanish CETME assault rifle, which, in turn, was developed from a German World War II rifle design. These rifles are unusual in that they function by retarded blowback and are constructed mostly from steel stampings. There are a variety of G3 rifles, including the conventional wood-stocked model, a folding-stock model, and a short-barreled carbine. These weapons can be found chambered for the 7.62x51-mm NATO cartridge or the 7.62x39-mm Soviet cartridge. The 7.62-mm NATO version is normally used only with the fixed wood or folding metal butt G3 models.

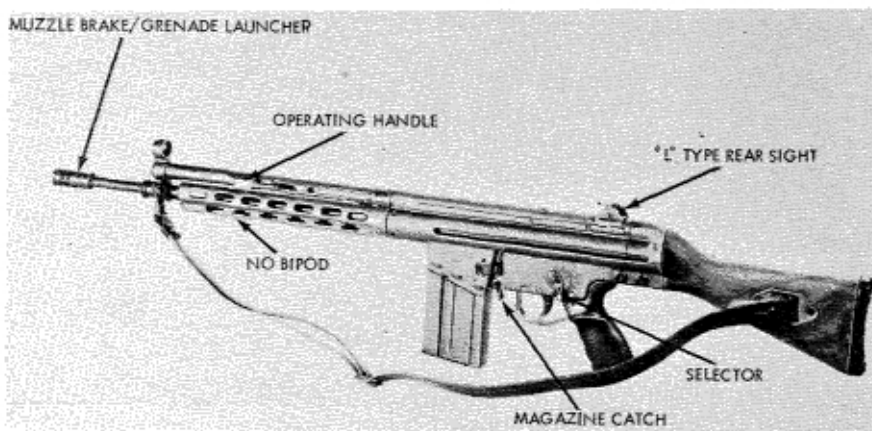

Neg. 510103

Figure 104. Early G3 (CETME) rifle.

b. The G3 is produced and used in West Germany, Spain, Norway, Sweden, Burma, and Portugal, and is also used by Indonesia, Ghana, Denmark, Nigeria, the Dominican Republic, Iran, Pakistan, and Liberia. The country of origin or use can usually be determined by the national markings on the weapon. The West German guns are stamped G-3, the Swedish guns are stamped AK-4, and the Portuguese guns are stamped m961.

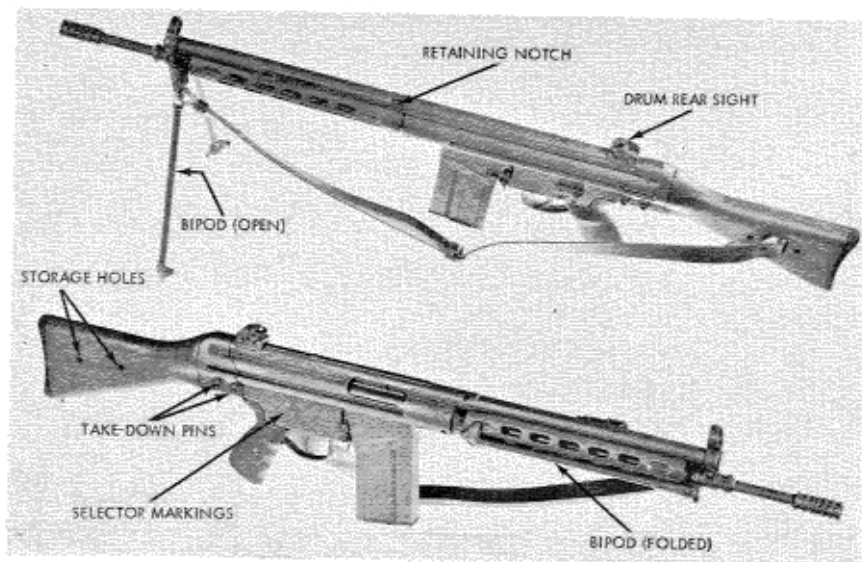

Neg. 510104

Figure 105. West German G3 rifle.

c. Most of the G3 rifles in use fire the 7.62x51-mm NATO cartridge. Refer to section V for information concerning ammunition used in this rifle.

145. Technical Data

Technical data concerning the G3 assault rifle are given in table V.

146. Operation

a. Load the magazine as described in paragraph 128a and insert the magazine into the rifle as described in paragraph 128b.

b. Rotate the selector (fig 104) to its uppermost position. This puts the rifle on safe.

c. Grasp the operating handle (fig 104), unfold it, and pull it fully to the rear; then release it. CAUTION: The rifle is now loaded.

d. Two types of rear sights are used. The early L-type (fig 104) is graduated for 200 and 300 meters; the later drum-type sight (fig 105) has a 100-meter V-notch and 200-, 300-, and 400-meter apertures. Flip the L sight or twist the drum sight to the desired range.

e. To fire the G-3, rotate the selector down from the safe position. The middle position gives semiautomatic fire; the lowest position gives full automatic fire. Using a normal sight picture, aim, and press the trigger to fire. The bolt will remain forward when the last round is fired. The operating handle will always remain forward during firing.

f. Press the magazine catch (fig 104) forward and pull the magazine out of the rifle.

g. Clear the G3 by rotating the selector (fig 104) upward to the safe position. Remove the magazine (f above) and pull the operating handle to the rear; then rotate it up into the retaining notch (fig 105). Inspect the rifle to insure that no cartridges are present. Pull the operating handle rearward, rotate it downward out of the retaining notch, and release it. Rotate the selector from safe, press the trigger, and return the selector to safe. Insert the magazine.

h. By using the screws, the drum rear sight can be adjusted for elevation and windage zero.

147. Disassembly and Assembly

a. To disassemble the weapon, clear the rifle (para 146g), but do not press the trigger or reinsert the magazine. Leave the selector set on safe.

b. Remove the takedown pins and place them in the stock storage holes for safekeeping (fig 105). Pull the butt stock and driving spring off to the rear.

c. Allow the trigger group to hang down on its front pin. Pull the operating handle to the rear and point the muzzle upward until the bolt assembly can be grasped and withdrawn to the rear.

d. Turn the bolt head (fig 106) 90° to the right and pull it forward out of the carrier. Turn the locking cam (fig 106) until its lug clears the carrier; then remove the locking cam, the firing pin, and the spring.

e. No further disassembly is necessary or advisable.

f. To reassemble the rifle, insert the locking cam and the firing pin, with its spring into the bolt head. Insure that the lug on

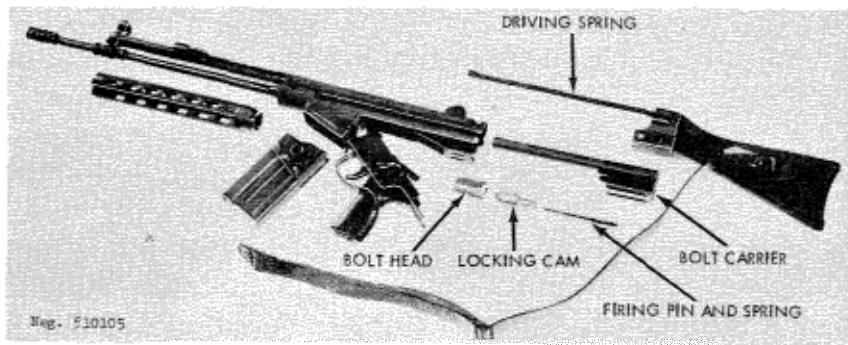

Figure 106. G3 disassembled.

the locking cam is aligned with the rounded side of the bolt head. Place the bolt head (bolt face down) on a firm surface and place the bolt carrier on the assembled bolt head/locking cam unit. Strike the rear end of the bolt carrier (fig 106) a firm blow with the hand to seat the bolt head against the carrier. Turn the bolt head slightly to the left; pull it forward about one-fourth inch, and then rotate it fully to the left. If the bolt head is pushed back into the carrier, the rollers will lock outward, and the bolt cannot be assembled into the rifle. If this happens, swing the trigger group down on its pin. Reverse the bolt unit and insert it into the receiver as far as possible. Strike the projecting driving spring tubular housing (on the bolt carrier) a sharp blow. This will cause the rollers to retract into the bolt, and the entire unit will go farther into the receiver. Remove the reversed bolt unit and proceed as in the following paragraph.

g. Insure that the locking rollers are flush with sides of the bolt head; then insert the complete bolt assembly into the receiver and point the muzzle down; the bolt will slide forward.

h. Swing the trigger group up into place; then slide the butt over the rear of the receiver and insure that the driving spring enters its recess in the bolt carrier. Remove the takedown pins

from their storage holes and replace them in the receiver. Insert the magazine, rotate the selector off safe, and press the trigger. Replace the magazine.

148. Functioning

a. The G3 rifle is delayed blowback operated; the rearward thrust of the cartridge case, upon firing, drives the bolt mechanism rearward, but the rearward movement is delayed by the mechanical arrangement of the bolt until the pressure in the rifle has dropped to a safe limit. There is, however, a slight rearward movement of the fired cartridge case. In order to ease this movement and prevent ruptured cartridge cases, the front end of the chamber is fluted. These flutes (fig 107) allow propellant gases to leak rearward along the cartridge case; this provides a film of gas upon which the mouth of the cartridge floats. Fired cartridge cases from this rifle are readily identified by the sharply defined gas marks that extend back for about half the length of the case.

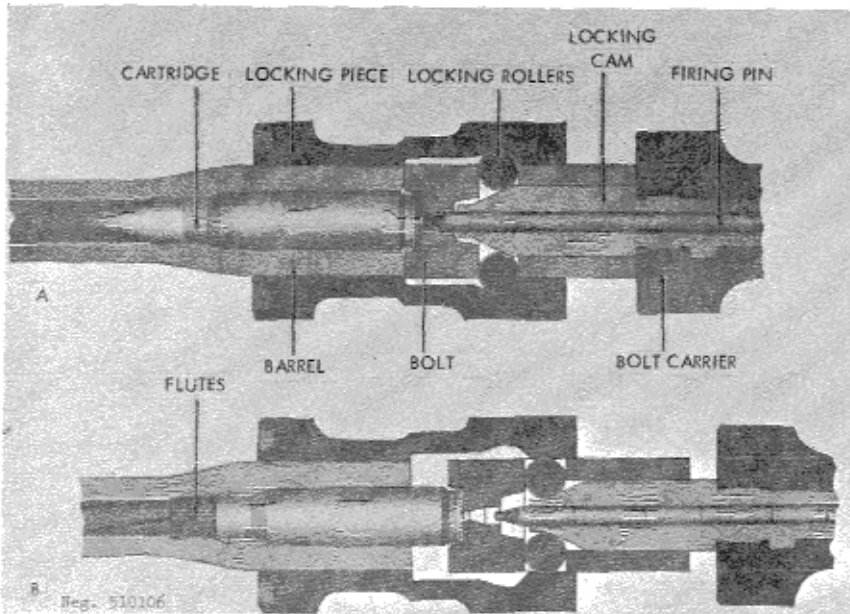

Figure 107. G3 bolt functioning.

b. When the G3 is ready to fire, a cartridge is chambered, the locking cam forces the locking rollers into their recesses, and the hammer is cocked. When the trigger is pressed, the hammer is released and strikes the firing pin, which fires the cartridge. The gas pressure generated drives the cartridge case rearward, and this movement is resisted by the bolt head whose locking rollers are seated in the locking piece (fig 107) attached to the barrel.

c. The rearward thrust of the case is sufficient to start the bolt rearward; this causes the rollers to be forced out of their seats. As they move, the rollers ride on the cam surface of the locking cam (fig 107) and force it rearward; because the cam is locked to the heavy bolt carrier, the bolt carrier is also forced to the rear against the driving spring. The delay, occasioned by the rollers resisting camming the heavy bolt carrier rearward, allows time for the bullet to leave the muzzle and the pressure to drop to a safe level. The inertia developed and residual gas pressure still thrusting the bolt rearward provide sufficient energy to drive the bolt fully rearward, to compress the driving spring, and to cock the hammer.

d. The extractor pulls the fired cartridge case from the chamber and holds it to the bolt face. The rear end of the ejector (fig 108) is struck by the recoiling bolt carrier; this causes the ejector to pivot so that its front end enters the bottom of the bolt head. As the bolt continues to recoil, the cartridge case strikes the ejector, pivots about the extractor, and is expelled from the rifle.

e. The bolt carrier strikes the buffer (fig 108) at the front of the butt stock and stops. The driving spring then drives the carrier forward, and the bolt head forces the top cartridge out of the magazine and into the barrel. The extractor snaps into the cartridge groove, and the forward movement of the bolt head stops when it hits the end of the barrel. The carrier has a lock to keep the bolt head locked forward; this is now tripped by a lug in

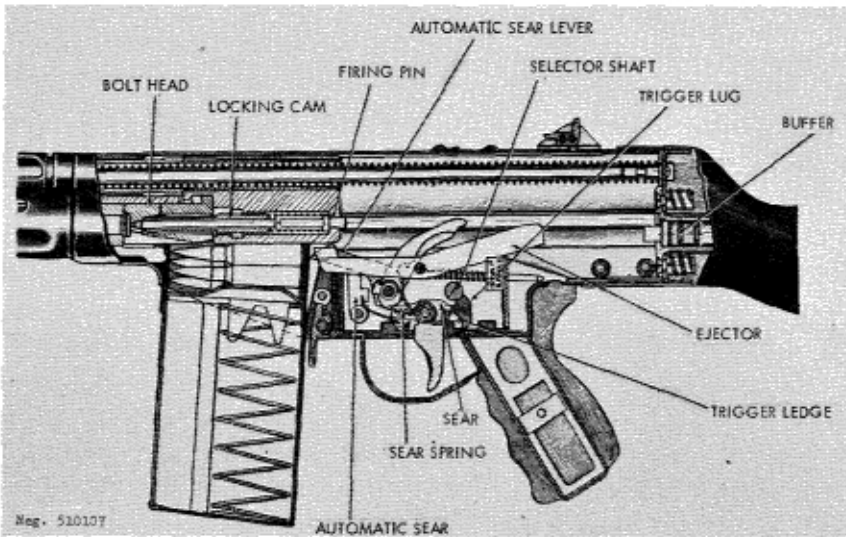

Figure 108. G3 rifle section.

the receiver. The carrier continues forward, and the locking cam, which travels with the carrier, forces the locking rollers into their recesses (fig 107).

f. The rifle's trigger mechanism is similar to that of the FN/FAL rifle (para 130f and g). The hammer, powered by a coil spring and plunger, is held cocked by a sear that can move back and forth in relation to the trigger. When the hammer is cocked, pressure on the trigger is transmitted to the rear end of the sear through the trigger ledge (fig 108). This causes the front of the sear to move down and release the hammer. The hammer, under pressure of its spring, swings forward and strikes the firing pin. Upon firing, the recoiling bolt carrier rocks the hammer back to its cocked position.

g. When the selector is set for semiautomatic fire, a cutaway section on the selector shaft limits the upward movement of the trigger lug (fig 108). When the trigger is pressed and the

hammer is released, the sear spring forces the front of the sear forward and upward. As the bolt carrier returns forward, the hammer starts to move forward, and the sear mates with a notch on the hammer. When this happens, the strong hammer spring overcomes the weak sear spring, and the sear is forced rearward against the trigger ledge to hold the hammer cocked. By releasing the trigger, the ledge is lowered, and the hammer spring, working through the hammer, forces the sear rearward over the ledge. Pressure on the trigger will now move the sear and fire another shot.

h. When the selector is set for automatic fire, the trigger can rise to its highest point, and the nose of the sear is depressed far enough so that the sear cannot reengage the hammer. The automatic sear (fig 108), however, holds the hammer cocked, and as the bolt carrier completes its forward travel, it depresses the automatic sear lever (fig 108); this, in turn, moves the automatic sear out of engagement with the hammer. The hammer swings forward to fire, and this action is repeated until the trigger is released. The sear can then rise, intercept the hammer, and interrupt the firing cycle.

i. When set at safe, the selector places a solid section of its shaft over the trigger lug. This prevents the trigger from moving enough to disengage the sear from the hammer and keeps the weapon from firing.

j. There are two automatic safeties on the G3: the automatic sear and the locking cam. If the mechanism is not fully forward, the automatic sear will continue to hold the hammer and prevent firing. The locking cam, unless it is fully forward and holding the locking rollers fully outward, will prevent the firing pin from protruding through the bolt face, and the weapon cannot fire if the bolt is not fully locked.

3 February 1984

149. Accessories

a. The G3 is usually issued with a canvas or leather sling, spare magazines, a magazine carrier, and a bayonet. Some G3 rifles may be equipped with telescopic or infrared sights.

b. The bayonet is installed by fitting its ring over the muzzle and guiding the belt into engagement with the bayonet lug between the bipod (early models) or with the plug in front of the front sight. In either case, the bayonet is removed by pressing its catch and pulling it forward, off the rifle.

c. Some G3's have bipods built into their forestocks. Pull the legs down or fold them up against spring pressure as desired.

d. Rifle grenades may be launched from the G3. The flash suppressor can be used as a launcher. Refer to paragraph 155a for precautions. No adjustment is necessary for firing grenades from the G3; just insert the special blank cartridge into the chamber, slide the grenade into place, aim, and fire.

G. THE 7.62-MM BERETTA BM-59 RIFLE (ITALY)

150. General

a. The Italian BM-59 rifle (fig 109) is based upon the design of the US caliber .30 M1 rifle and

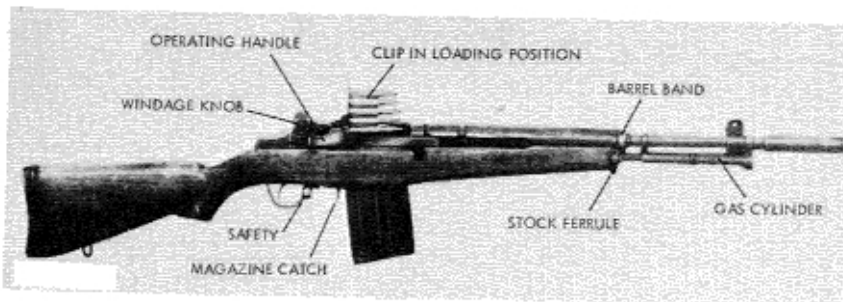

Neg. 510108

Figure 109. Italian BM 59 Mark 1 Rifle

resembles the US 7.62-mm M14 rifle. The BM-59 is gas operated, selective fire, and is fed from 20-round detachable box magazines. There are several distinct models of the BM-59, differing primarily in stock design and muzzle devices. All are mechanically identical. The Italian Army uses the BM-59 Mark ITAL (fig 110) and the BM-59 Mark ITAL-A (fig 111) as standard weapons. The other versions are offered for sale and may be encountered in use in some of the smaller armies. BM-59 rifles were also produced in Indonesia.

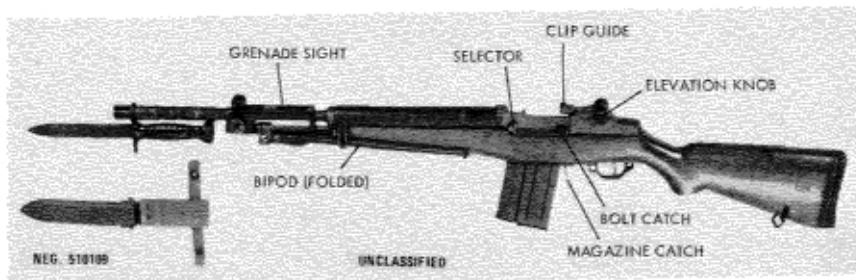

Neg. 510109

Figure 110. BM-59 Mark ITAL Rifle

b. All versions of the BM-59 fire the 7.62x51-mm NATO cartridge (sec V).



Neg. 510110

Figure 111. BM-59 Mark ITAL-A Paratroopers Rifle

151. Technical Data

Technical data concerning the BM-59 will be found in table V.

152. Operation

a. Press the magazine catch (fig 109) toward the magazine and simultaneously rotate the bottom of the magazine forward until the magazine releases from the rifle and can be removed. Load the magazine as described in paragraph 128. Insert the magazine into the receiver and strike with the heel of the hand to insure the magazine is firmly caught in place.

b. If desired, leave the magazine in place, pull the operating handle (fig 109) fully rearward, and release; the bolt will be held open. Insert NATO five-round stripper clips into the clip guide (fig 110) and press the cartridges off the clip into the magazine. Individual rounds can also be placed on the follower and pressed down into the magazine. Adjust the sight for desired range (para 152g).

c. Pull the operating handle (fig 109) fully to the rear and release it. CAUTION: The rifle is now loaded and ready to fire. It is a good practice to tap the operating handle to insure that it is fully forward. If the rifle is not to be fired immediately, press the safety (fig 109) toward the trigger.

d. If the BM-59 has a bipod, swing it down into position and open the hinged butt plate if the rifle is to be fired from the prone position (if the weapon is so equipped).

e. Set the selector (fig 110) for the type of fire desired: forward for automatic fire, rearward for semiautomatic fire. Push the safety (fig 109) forward. Aim (using a normal sight

picture), and press the trigger. The weapon will fire according to the selector setting. The bolt will remain closed between bursts or shots and open when the last cartridge in the magazine is fired.

f. Clear the BM-59 by first pressing the safety (fig 109) to the rear, then pressing the magazine catch (fig 109) and removing the magazine. Pull the operating handle (fig 109) rearward, press in the bolt catch (fig 110), and ease the operating handle forward until the bolt is held open. Inspect to insure that no cartridges are present. Pull the operating handle rearward and release it, then insert the magazine. Press the safety forward and press the trigger.

g. Adjust the rear sight for the desired range by twisting the elevation knob (fig 110), located to the left of the rear base, until the desired range (number \times 100 meters) aligns with the index mark on the receiver. Windage is adjusted by rotating the right-hand knob (fig 109) in the appropriate direction as indicated by the arrow engraved on the knob. The elevation knob can be adjusted for zero by firing the rifle at a known distance target and adjusting the sights until satisfactory results are obtained. Without changing sight elevation, loosen the screw in the center of the elevation knob, turn the drum so that the appropriate range indicator is aligned with the receiver index line, and retighten the screw.

153. Disassembly and Assembly

a. Clear the rifle but do not insert the magazine. Pull the rear of the trigger guard back to unlatch it, then swing the trigger guard down and forward. Pull the entire trigger group straight out of the weapon.

b. Invert the rifle, grasp the stock behind the receiver, and pull the stock away from the barrel and receiver.

c. Invert the barrel and receiver. Grasp the driving spring close to its rear end and force it forward until the driving spring guide comes free. Move the spring and guide to one side and ease them rearward to remove. Pull the operating rod to the rear while applying downward pressure on the handle. When the rod snaps into its dismounting notch, pull the rod sideways, away from the receiver. Pull the disengaged rod to the rear and lift up the handle until the rod can be removed from the gas cylinder.

d. Turn the barrel and action upright. Grasp the bolt by the protruding lug and pull it forward and outward until the bolt comes out of the receiver. No further disassembly is necessary or desirable.

e. To reassemble, hold the bolt at an angle to the receiver and insert the bolt into the receiver so that the firing pin tang slips behind the lower bridge across the receiver. Twist the bolt and move it rearward until it seats in the receiver. Invert the barrel and receiver with the bolt to its rearmost position.

f. If the front driving spring guide has been removed, insert it into the operating rod, large end first. Insert the operating rod piston into the gas cylinder and move the operating rod into the gas cylinder until the rod drops down on the barrel. Engage the cam of the operating rod with the lug on the bolt. Push the operating rod in, toward the receiver, and move it forward until it snaps into place. Push the operating rod fully forward. Slide the driving spring into the operating rod until the driving spring guide can be seated against the front receiver insert.

g. Engage the ferrule on the front of the stock with the barrel band (fig 110). Lower the stock onto the barrel and receiver. Insert the trigger group straight into the opening on the stock, insuring that the ribs on the trigger housing mate with their grooves in the receiver. Fully seat the trigger housing and press the

trigger guard shut. Be sure that the trigger guard locks into place. Insert the magazine.

154. Functioning

a. The BM-59 is gas operated; refer to paragraph 138a.

b. When the weapon is loaded and the trigger pressed, the hammer strikes the firing pin and fires the cartridge. The propellant gases drive the bullet down the barrel bore and, after the bullet passes the gas port, some of the propellant gases enter the gas cylinder (fig 109) and drive the operating rod rearward. The driving spring is compressed, the hammer rocked rearward, and, after a short distance, the cam in the operating rod hump contacts the bolt operating lug. Continued operating rod travel causes the bolt to rotate to its unlocked position and then move rearward. The extractor pulls the fired cartridge case from the chamber (initial extraction occurred as the bolt unlocked by the left-hand locking lug contacting a cam surface) and holds it to the bolt until the fired case clears the chamber. The spring-loaded ejector expands and hurls the fired case out of the weapon. The operating rod finally strikes the front of the receiver and stops. The driving spring then forces the operating rod and bolt forward. As the bolt moves, its feed rib drives the top cartridge out of the magazine and into the chamber. The bolt stops when it strikes the barrel, but the operating rod continues forward. During this final forward movement, the cam in the operating rod rotates the bolt to its locked position; as this occurs, the extractor snaps into the groove of the cartridge case and the ejector spring is compressed. Forward motion ceases when the end of the cam groove in the operating rod strikes the operating lug of the bolt.

c. When the trigger is pressed, the trigger disengages from the front hammer hooks. The hammer, under pressure of the

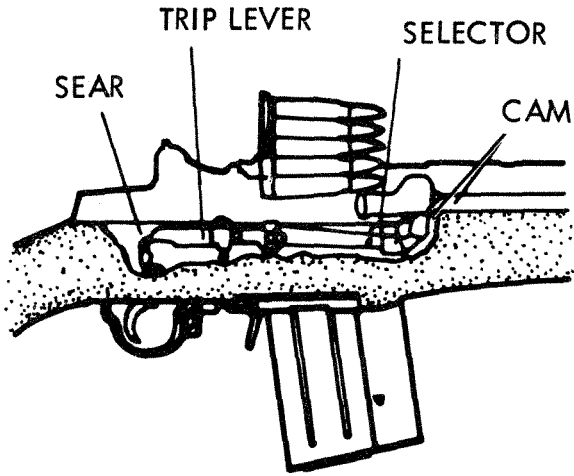

Neg. 510111

Figure 112. BM-59 Mechanism

hammer spring, swings forward to fire the weapon. As the bolt recoils, after a shot is fired, the hammer is rocked rearward, and the rear hammer hooks pass the sear (fig 112), forcing it rearward against pressure from the hammer spring. When the bolt returns forward, the hammer is held cocked by the sear.

d. When the selector is set for automatic fire, the trip lever rises to engage the operating rod, and the operating rod cams down the front end of the trip lever. The trip lever pivots and its rear end forces the sear rearward, releasing the hammer (fig 112). The hammer swings forward and fires another shot. This action continues as long as cartridges are in the magazine and the trigger is pressed. When the trigger is released, the trigger lugs swing rearward and catch the front hammer hooks when the trip lever actuates the sear. The fire again, the trigger must be pressed.

e. When the selector is moved to its semi-automatic position, the front of the trip lever is

lowered so it cannot engage the operating rod and thus not actuate the sear. The hammer is now caught by the sear. To fire another shot, the trigger must be released; this allows the trigger lugs and sear to move rearward. The sear releases the hammer, the front hooks of which are then caught by the trigger lugs. The trigger must now be pressed to fire another shot.

f. When the safety is applied, it rotates, and its upper forward end engages a lug on the side of the hammer. As the engagement is made, the hammer is cammed slightly rearward so that its hooks are out of engagement with the trigger lugs. As the safety is rotated, a second lug swings into place in front of the trigger lug and prevents movement of the trigger.

g. The follower, when the magazine is empty, applies pressure against the bolt catch and, after overcoming the force of the light bolt catch spring, forces the bolt catch to pivot inward. The rearward moving bolt will override the bolt catch; however, the bolt catch will intercept the bolt's left locking lug when the bolt moves forward. This holds the bolt open and indicates that the magazine is empty.

155. Accessories

a. The BM-59 can be used to launch 22-mm inside diameter tubed grenades. The compensator (fig 111) also serves as a grenade launcher and a muzzle brake. BM-59's used to fire grenades are equipped with a folding grenade sight (fig 110). Prior to firing a grenade, erect the sight; this will automatically cut off the gas mechanism. Load the rifle with a grenade-launching cartridge. (CAUTION: Never use a cartridge with a bullet! Use only special launching cartridges without bullets. Use of bulletted rounds to launch grenades will kill the shooter!) Place the weapon on safe and slide a grenade over the launcher. The grenade must slide onto the launcher

easily, without force. To fire, push the safety forward, align the desired range bar of the sight with the ogive (diameter) of the grenade, and align the whole weapon upon the target. Press the trigger. (CAUTION: Recoil is severe! Do not brace the body against any solid object when firing rifle grenades.)

b. Some rifle stocks have a recess for cleaning equipment and oil. A combination screwdriver, punch and chamber brush; a vial of rifle grease; and a tube of oil are carried in the recess.

c. A winter trigger is available. This unit extends the trigger below the guard so that the trigger can be operated by a gloved hand.

d. A blank firing device, which is secured to the muzzle attachment, permits automatic firing of blank cartridges.

H. THE 7.5-MM MODEL 49 AND 49/56 RIFLES (MAS 49 AND MAS 49/56) (FRANCE)

156. General

a. At the end of World War II the French Army was equipped with a variety of obsolete and foreign rifles. To correct this situation, a crash program was started to develop a new rifle. The result was the Model 49 rifle (fig 113), usually referred to as the MAS 49. This weapon is a gas-operated, semiautomatic, magazine-fed arm, equipped with an integral,

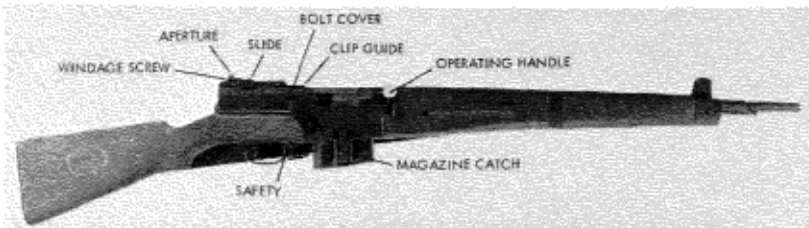

Neg. 510112

Figure 113. French M.A.S. 49 Rifle

adjustable grenade launcher (fig 114). All Model 49's are equipped with a telescopic sight base on the left side of the receiver.

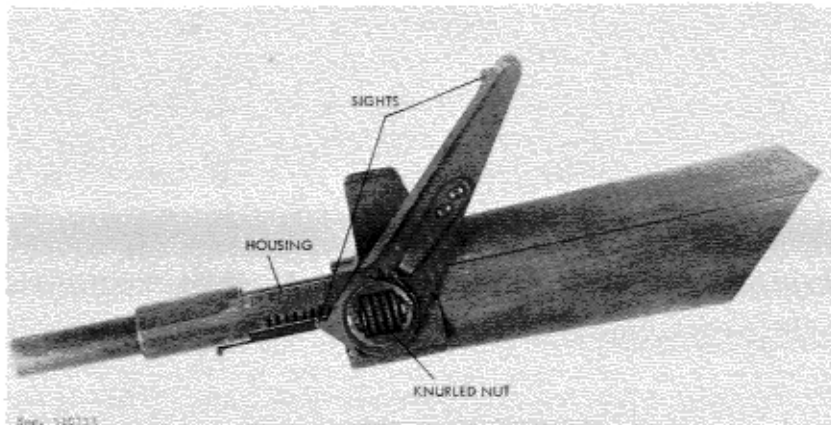

Neg. 510113

Figure 114. M.A.S. 49 Grenade Launcher

b. The Model 49 was extensively modified in 1956. The resulting weapon, the Model 49/56 (fig 115), has a shortened forearm, a new combination muzzle brake/grenade launcher, and minor internal changes. The Model 49/56 became the standard rifle of the French Army, and most Model 49's were converted to the M49/56 version. Only the French Army and a few of the former French possessions use the M49 or M49/56 rifles.

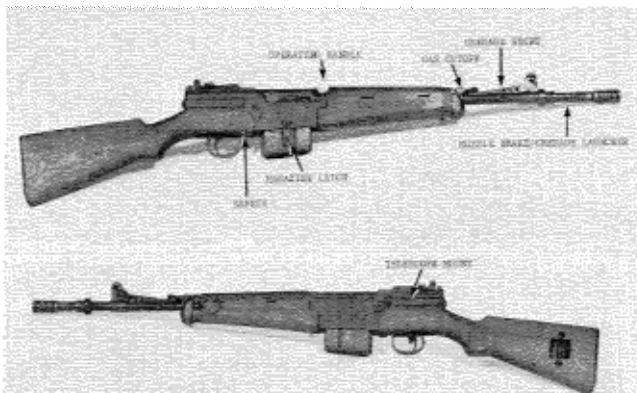

Neg. 510114

Figure 115. M.A.S. 49/56 Rifle

c. While some experimental Model 49 rifles were produced to fire the 7.62x51-mm NATO cartridge, the standard M49 and M49/56 rifles fire the 7.5x54-mm cartridge (sec V).

157. Technical Data

Technical data pertaining to the Model 49/56 rifle will be found in table VI.

158. Operation

a. The Model 49 and Model 49/56 rifles are operated in the same manner except for the grenade launcher.

b. Press the lower end of the magazine catch (fig 113 and 115) against the magazine and pull the magazine out of the receiver. Place a cartridge on the magazine follower and press the cartridge down until it snaps under one of the feed lips; repeat until the magazine is filled with ten cartridges. Insert the loaded magazine into the receiver until the magazine catch snaps into place. Alternatively, the operating handle (fig 113 and 115) can be pulled rearward as far as possible and released. The bolt will be caught open. Insert a charger into the clip guide (fig 113) at the front of the bolt cover and, with the thumb, press the cartridges off the guide and into the magazine. Repeat with a second five-round charger.

c. Pull the operating handle (fig 113 and 115) fully rearward and release it. CAUTION: The rifle is now loaded and ready to fire. If immediate firing is not intended, render the rifle safe by rotating the safety (fig 113 and 115) downward.

d. Adjust the rear sight for range by pressing down on the aperture (fig 113) and then moving the slide (fig 113) to the number that corresponds with the range in hundreds of meters.

Windage adjustments can be made by using a screwdriver to turn the windage screw (fig 113).

e. To fire, rotate the safety upward, aim (using a normal sight picture), and press the trigger. The rifle will fire once; the trigger must be released and repressed to fire another shot. The bolt will close between shots and remain open when the last round is fired.

f. To launch grenades, first clear the rifle (para g below). Do not insert the magazine. Load a special non-bulleted, grenade-launching cartridge into the chamber and close the bolt. Rotate the safety (fig 113 and 115) downward. Erect the grenade sight (fig 113 and 115).

(1) If the rifle is a Model 49, rotate the knurled nut (fig 114) until the range, in tens of meters (to 260 meters), is aligned with the housing (fig 114). Slip a grenade fully onto the launcher and align the grenade sights with the target. Rotate the safety upward and press the trigger.

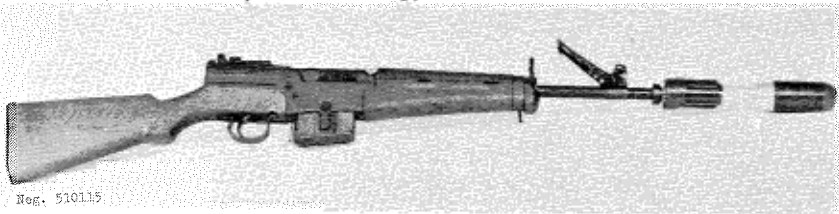

Figure 116. M.A.S. 49/56 with rifle grenade.

(2) If the rifle is a Model 49/56, slide the grenade over the launcher and seat it fully onto the range slide (fig 116). The retainer spring on the range slide prevents the grenade from slipping off the rifle. Press the button (fig 117) on the range slide and move the slide back or forth on the barrel until the rear edge of the range slide aligns with the number corresponding to the

proper range (to 200 meters). Erect the sight to its highest point (fig 117) and use the open sight to align the grenade on target. This sight and range technique is used only for indirect fire with antipersonnel grenades. For antitank grenades or direct fire, move the range slide back to the 20 graduation and, with the grenade sight in its highest position, align the appropriate arc on the sight with the grenade ogive (largest diameter) and target (fig 117). Once sighted, rotate the safety upward and press the trigger.

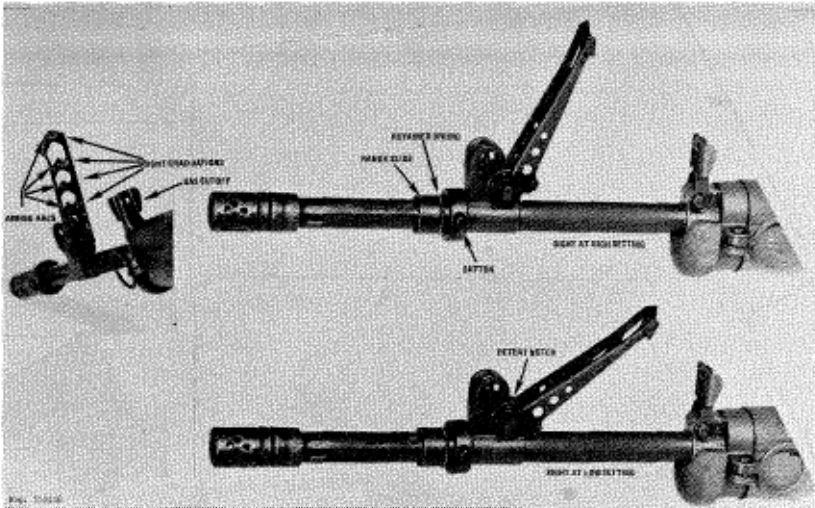

Figure 117. M.A.S. 49/56 grenade launcher and sight.

(3) When finished launching grenades, fold the grenade sights down and, in case of the M49, withdraw the range sleeve into the front end by rotating the knurled nut.

g. To clear the rifle, rotate the safety forward, press the magazine catch (fig 113 and 115), and remove the magazine. Pull the operating handle (fig 113 and 115) fully to the rear. Inspect to insure that no cartridges are in the barrel or receiver, release the operating handle, squeeze the trigger, rotate the safety rearward, and insert the magazine.

159. Disassembly and Assembly

- a. The M49 and M49/56 are disassembled identically.
- b. Clear the rifle (para 158g) but do not squeeze the trigger or insert the magazine.
- c. Press down the cover catch (fig 118) at the rear of the receiver and, while the catch is in, push the receiver cover forward until the rear end can be eased up, out of the receiver. Allow the receiver cover to move rearward until it can be removed. Pull out the driving spring. Move the operating handle rearward until the bolt carrier (fig 118) can be lifted out of the receiver. Lift out the bolt (fig 118). No further disassembly is required or desirable.

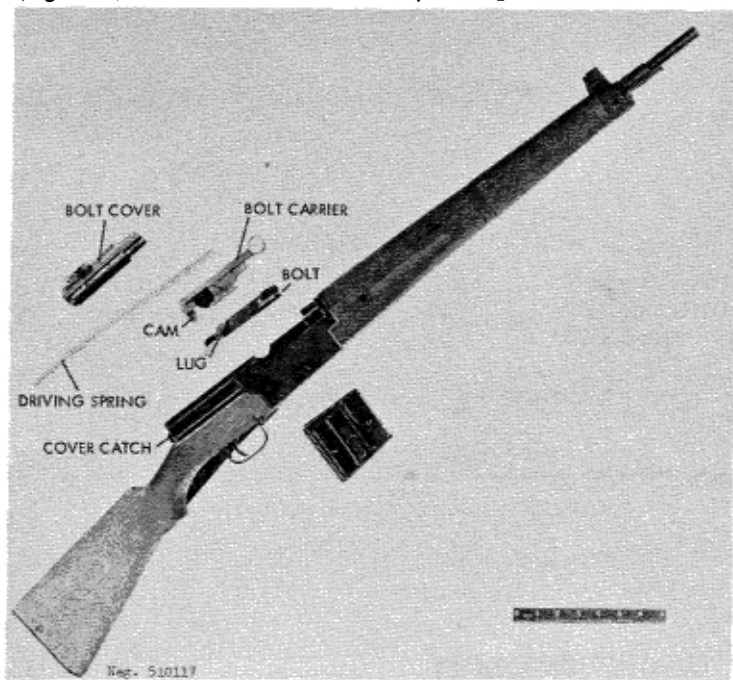

Figure 118. M.A.S. 49 disassembled.

d. To reassemble, insure that the hammer is cocked, then place the bolt, large end forward, into the rear end of the receiver. Set the bolt carrier down, over the bolt, and move the bolt carrier back and forth until it mates with the bolt. Push the operating handle fully forward.

e. Put the driving spring over its guide in the receiver cover, then insert the front end of the spring into the bolt carrier. Place the receiver cover onto the receiver and press the receiver cover forward and down, against the pressure of the driving spring, until the receiver cover seats into the receiver. Use the core to prevent the driving spring from becoming kinked. Ease the receiver cover rearward until it locks into place. Insert the magazine.

160. Functioning

a. The M49 and M49/56 function identically. The rifles are gas operated. Upon firing, some of the gas that propels the bullet is tapped off and directed back, through a gas tube, into the bolt carrier (fig 119). The gas impulse drives the bolt carrier rearward. The driving spring compresses and the hammer rocks back, compressing its spring. After a short distance, cam grooves (in the rear of the bolt carrier) contact lugs on the bolt (fig 119) and lifts the rear of the bolt up, out of the locking recess in the receiver.

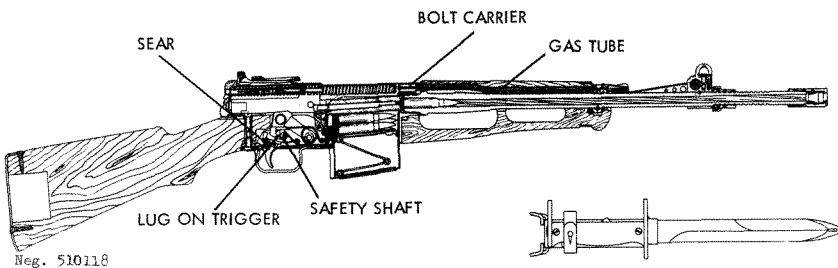

Figure 119. M.A.S. 49/56 section.

b. The bolt and carrier now move rearward as a unit. The extractor pulls the fired cartridge case out of the chamber and holds the case against the bolt face until the ejector expels the fired case. Rearward movement ceases when the bolt carrier strikes the rear of the receiver.

c. When the hammer is cocked, a hook on the hammer is caught by a lug on the trigger (fig 119). When the trigger is pressed, it rotates about its pin, and its lug releases the hammer. Concurrently, the spring-loaded sear, pivoted to the rear of the trigger (fig 119), rotates forward. The hammer spring swings the hammer forward to fire the cartridge.

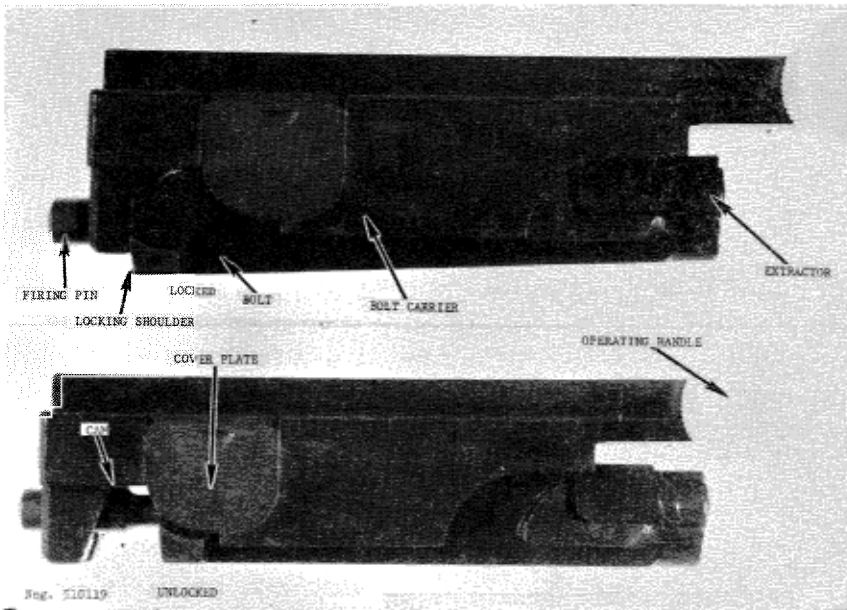

Figure 120. M.A.S. 49/56 bolt.

d. Upon recoil of the bolt, the hammer rocks back, and as its rear hook passes the sear, it forces the sear back against its

spring. When the bolt counterrecoils, the sear, which has returned to its normal position, intercepts the rear hook of the hammer and holds the hammer back.

e. The trigger must be released prior to firing another shot. When released, the upper end of the trigger rotates rearward. The sear releases the hammer, but, because of the rearward movement, the hammer hook is caught by the trigger lug. To fire another shot, the trigger must be pressed to recommence the firing cycle.

f. When the safety (fig 113 and 115) is rotated rearward to safe, the solid portion of its shaft (fig 119) rotates in front of the trigger and thus prevents forward trigger motion. When the safety is rotated forward to the fire position, a cutaway section of the shaft moves in front of the trigger and no longer blocks its movement.

g. When the small leaf of the grenade sight of the M49/56 is lifted, its shaft, through which the gas port is drilled, rotates. This misaligns the gas ports and automatically cuts off operating gas when launching grenades.

161. Accessories

- a. The many accessories for the M49/56 rifles include:
- (1) a telescopic sight.
 - (2) an infrared sight.
 - (3) a night sight (M49/56 only).
 - (4) a bayonet (49/56 only) (fig 121).
 - (5) cleaning equipment.
 - (6) leather web sling.

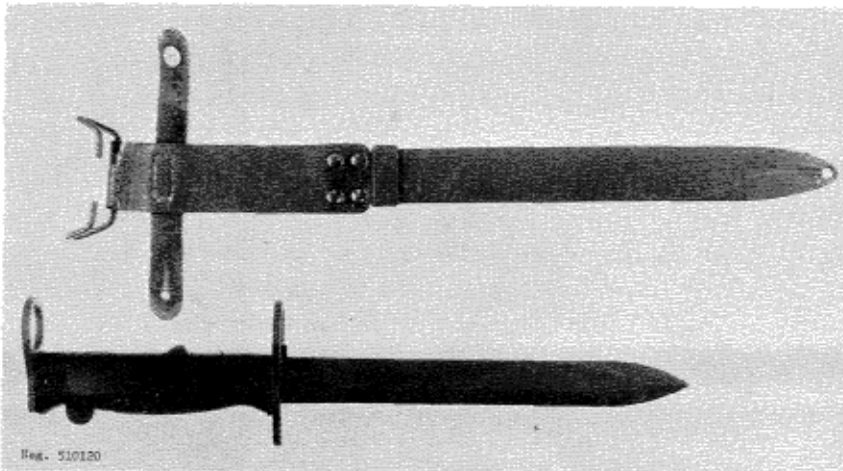

Figure 121. M.A.S. 49/56 bayonet.

b. The telescopic and infrared sights slide onto the sight base on the left rear of the receiver (fig 115) from rear to front. Swing the lever on the sight adapter forward to lock the sight to the rifle. Adjust the telescopic sight as described in paragraph 179c. The infrared sight is operated according to the instructions issued with the sight.

c. The night sight is slipped over the flash suppressor and front sight; then the clamp wing nut is tightened. Use the same aiming technique as described in paragraph 179c.

I. THE 7.5-MM StG 57 (SIG 510) ASSAULT RIFLE (SWITZERLAND)

162. General

a. The 7.5-mm StG 57 (Sturmgewehr 57) assault rifle is the standard Swiss Army rifle. This weapon, developed by the Swiss SIG Company, is also known as the SIG 510 when chambered for the 7.62-mm NATO cartridge. A small quantity of these rifles also were produced by Beretta in Italy and sold in

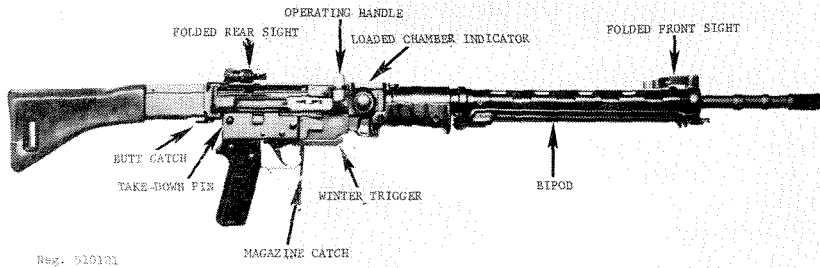

Figure 122. Swiss StG 57 assault rifle.

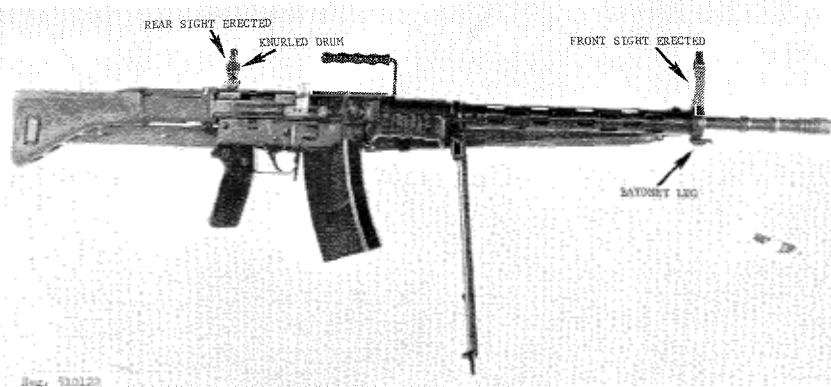

Figure 123. StG 57 with bipod extended.

South America. There is little military use of this rifle except by the Swiss Army; however, the SIG 510's are offered for commercial sales in both selective-fire and in semiautomatic fire models. The StG 57 (fig 122 and 123) is easily identified by its angular, ungraceful appearance; long, perforated tubular barrel jacket; folding sights; small plastic forearm; and plastic butt. Also, the Swiss cross is stamped over its chamber. The commercial SIG 510's are similar to the StG 57 but can be identified by their larger wood forearm (fig 124 and 125).

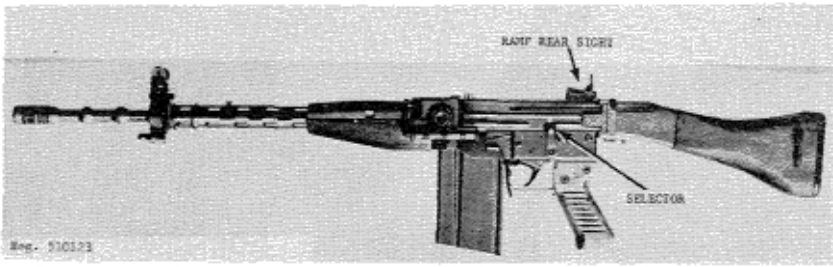

Figure 124. Swiss SIG 510-4 assault rifle.

b. The StG 57 (SIG 510) is a delay blowback-operated, detachable box magazine-fed, selective-fire weapon, although some commercial versions are capable of semiautomatic fire only. These rifles often are equipped with a folding metal bipod (fig 123), a fold-away winter trigger (fig 122), and a loaded-chamber indicator.



Figure 125. Early SIG 510 assault rifle.

c. The StG 57 fires 7.5x55.5-mm cartridges only; the SIG 510 series fire 7.62x51-mm cartridges (refer to sec V).

163. Technical Data

Technical data pertaining to the StG 57 assault rifle are presented in table V.

164. Operation

a. Load the magazine as described in paragraph 128a. Rotate the selector (fig 124) to its vertical (safe) position, aligned with the letter S. Hold the magazine so that the lips on its front edge can be mated to the recess in the receiver (fig 127); mate the lip with recess; then pull the bottom of the magazine rearward until the magazine catch snaps into place.

b. Move the front and rear sights to their erect position (fig 123) if an StG 57 or if equipped with folding sights. Adjust this model for range by rotating the knurled drum (fig 123) until the number corresponding to the range in hundreds of meters is aligned with the index work. If the rifle is a SIG 510 equipped with non-folding sights (fig 124), press the lock (fig 124) and move the sight along the base until the number on the sight base that corresponds to the range in hundreds of meters is aligned with the sight.

c. Grasp the operating handle (fig 122), pull it fully rearward, and release it. **CAUTION:** The rifle is now loaded. The loaded chamber indicator protrudes above the top front of the receiver to indicate that the rifle is loaded (fig 122 and 127). Rotate the selector forward off safe to the position for the desired mode of fire: T for semiautomatic fire, or A for fully automatic fire. Aim (using a normal sight picture), and press the trigger. The rifle will fire according to the mode of fire selected. The bolt will remain closed between shots or bursts of fire and when the last round in the magazine has been fired.

d. If gloves are worn, pull the winter trigger (fig 122) down. This trigger, extending outside the trigger guard, can be pulled by using two gloved fingers. **CAUTION:** This trigger is not guarded and can cause accidental discharges.

e. If the rifle is equipped with a bipod, the greatest accuracy is obtained by using it to steady the rifle while firing prone. Pull the bipod legs (fig 122 and 123) away from the barrel jacket until they lock into position. Fold the legs by pressing them back along the jacket.

f. To unload or clear the rifle, move the selector to its vertical (safe) position, press the magazine catch (fig 122) toward the magazine, and rock the magazine forward, out of the rifle. Pull the operating handle fully to the rear, hold it, and inspect to insure that no cartridges are present. Release the operating handle, move the selector off safe, press the trigger, move the safety back to safe, and insert the magazine. Fold the sights and winter trigger if necessary.

165. Disassembly and Assembly

a. Clear the rifle (para 164f) but do not move the selector off safe or insert the magazine. Press the butt catch (fig 123) on the stock behind the pistol grip and twist the butt stock one-eighth turn to the left until it disengages from the receiver. Remove the butt stock with the driving spring.

b. Pull the operating handle rearward until the bolt can be grasped and pulled out of the back of the receiver. The operating handle will come off the receiver if the handle is aligned with its disassembly notches in the receiver (fig 126).

c. Press in on the head of the takedown pin (fig 122) and pull the pin out, to the right. It will not come fully out of the trigger housing (fig 126). Pull the trigger housing off the receiver.

d. Further disassembly is neither necessary nor desirable.

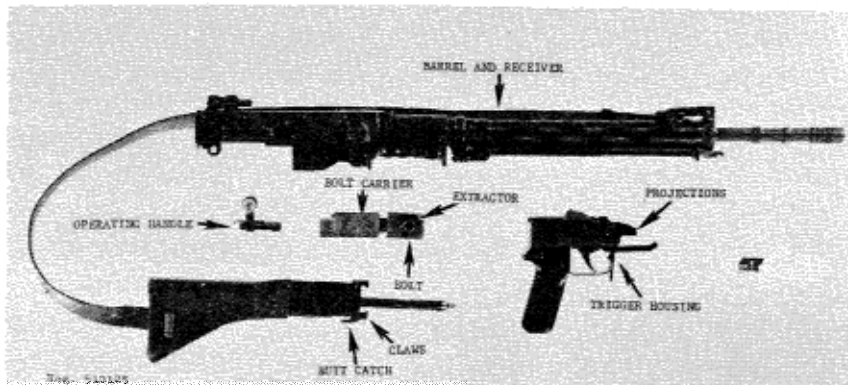

Figure 126. StG 57 disassembly.

e. To reassemble the rifle, engage the projections on the trigger housing (fig 126) with their seats on the sides of the receiver. Push the takedown pin fully home; it is necessary to press in the head to seat the pin fully.

f. Place the operating handle onto its rails on the receiver, with its small spring latch forward, and slide with the handle fully forward.

g. Start the bolt into the opening at the rear of the receiver. It may be necessary to move the extractor carefully to allow the bolt to enter the receiver fully. Once in the receiver, slide the bolt fully forward.

h. Slide the butt stock claws (fig 126) over the rear of the receiver. The stock must be twisted out of line with the receiver as this is done. Be sure that the point of the driving spring seats in the recess in the bolt, then twist the butt stock onto the receiver until the butt lock snaps into place. Clear the weapon as described in paragraph 164f.

166. Functioning

a. The StG 57 and SIG 510 function identically, and are both delay blowback operated. When the trigger is pressed, the hammer is released to strike the firing pin lever and fire the cartridge. The pressure generated during firing drives the cartridge case rearward, and the case (part 17, fig 127), in turn, attempts to drive the bolt (part 4, fig 127) rearward. The rearward movement of the bolt is, however, delayed because the two rounded locks (part 3, fig 127) are seated in recesses in the receiver and held there by the cam nose of the bolt carrier (part 9, fig 127). The rearward thrust of the bolt causes the locks to attempt to cam out of their recesses and as they do, their pressure against the cam nose of the bolt carrier forces the heavy carrier rearward. The delay caused by the locks coming out of their seats and forcing the heavy carrier rearward allows sufficient time for the bullet to leave the barrel for the gas pressure to fall to a safe level.

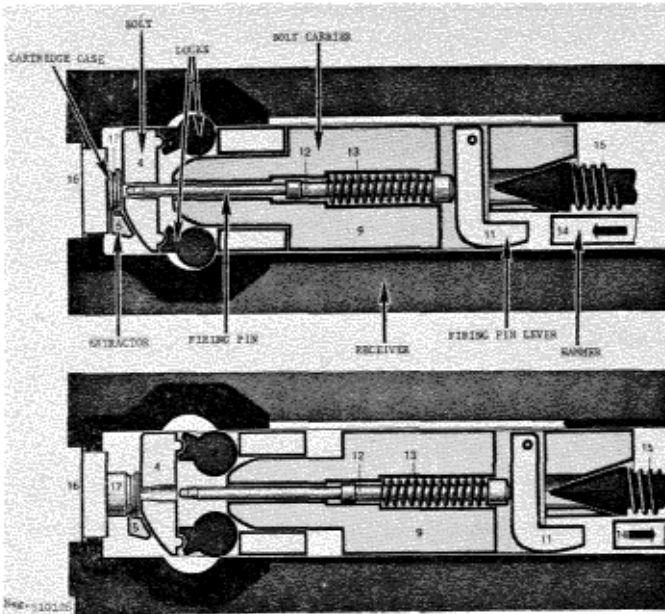

Figure 127. StG 57 bolt functioning.

b. The bolt carrier, however, has been given sufficient momentum to travel fully to the rear. As it does, it compresses the driving spring and rocks the hammer rearward. The extractor (part 5, fig 127 and 128) pulls the fired cartridge case out of the chamber and holds it to the bolt face. As the bolt nears the end of its travel, the ejector strikes a cam surface in the receiver (fig 129) and suddenly pivots on its pin. This throws the fired case out through the ejection port (fig 129).

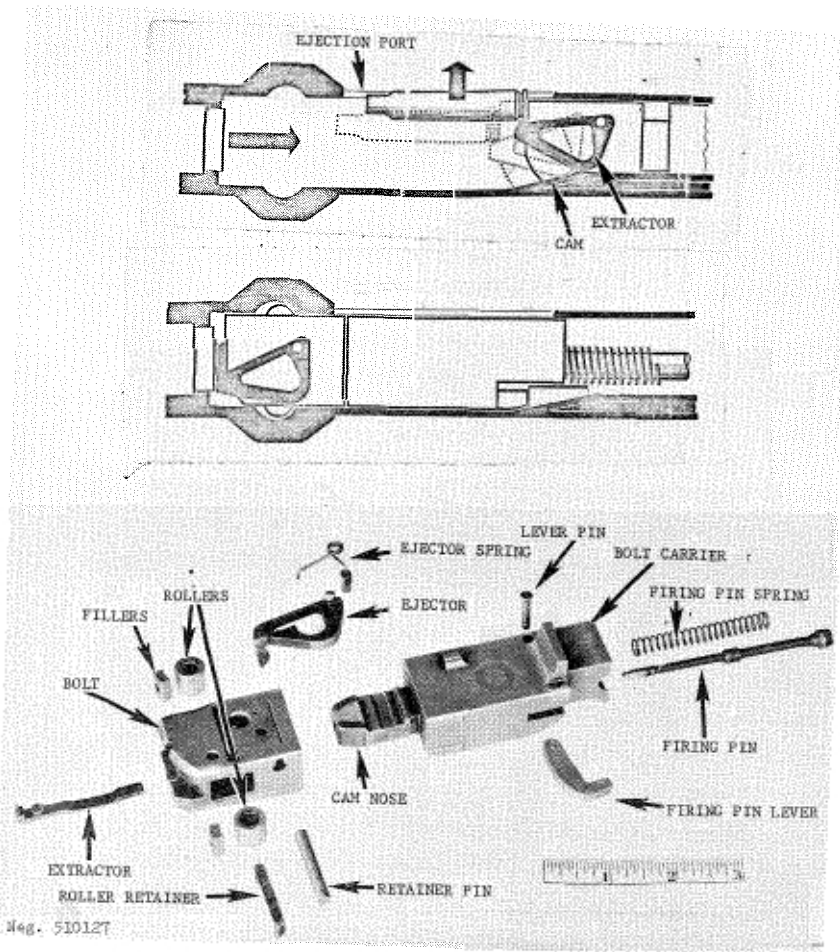

Figure 128. StG 57 bolt.

c. The bolt strikes the forward end of the butt stock and stops; the compressed driving spring then drives the bolt forward. The feed rib drives the top cartridge out of the magazine and into the barrel. As the bolt nears the end of its forward travel, the carrier cam nose forces the locks out into their recesses, and the extractor engages the rim of the cartridge. The bolt strikes the barrel, the carrier strikes the bolt, and forward movement ceases.

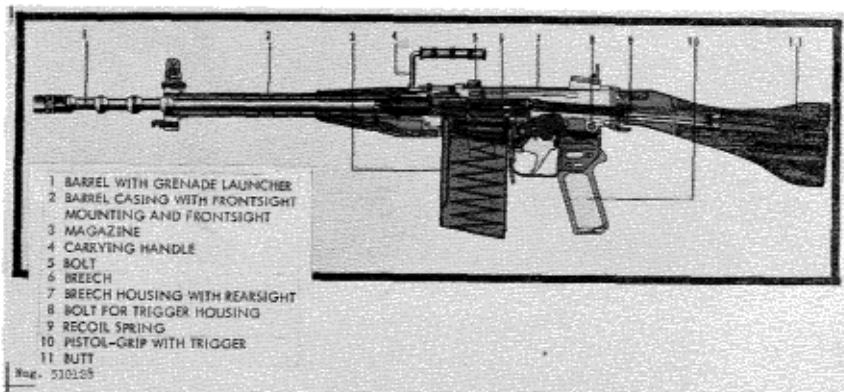

Figure 129. SIG 510-4 section.

d. The hammer (part 14, fig 127, 129, and 130) when released is driven by its spring (fig 130) and strikes the end of the firing pin lever (part 11, fig 122 and 130). This lever pivots on its pin and drives the firing pin (part 12, fig 127) forward to strike the cartridge primer.

e. When the selector is set at T for semiautomatic fire, it does not affect the components of the trigger mechanism. The trigger and the sear pivot on the same pin (fig 130). As the trigger is pressed, the connector (fig 131) moves upward and contacts the rear underside of the sear (fig 131). Continued trigger pressure causes the sear to pivot on the pin and release the hammer. The hammer swings forward and strikes the firing pin lever. The connector is a fairly heavy part, with most of its weight above its

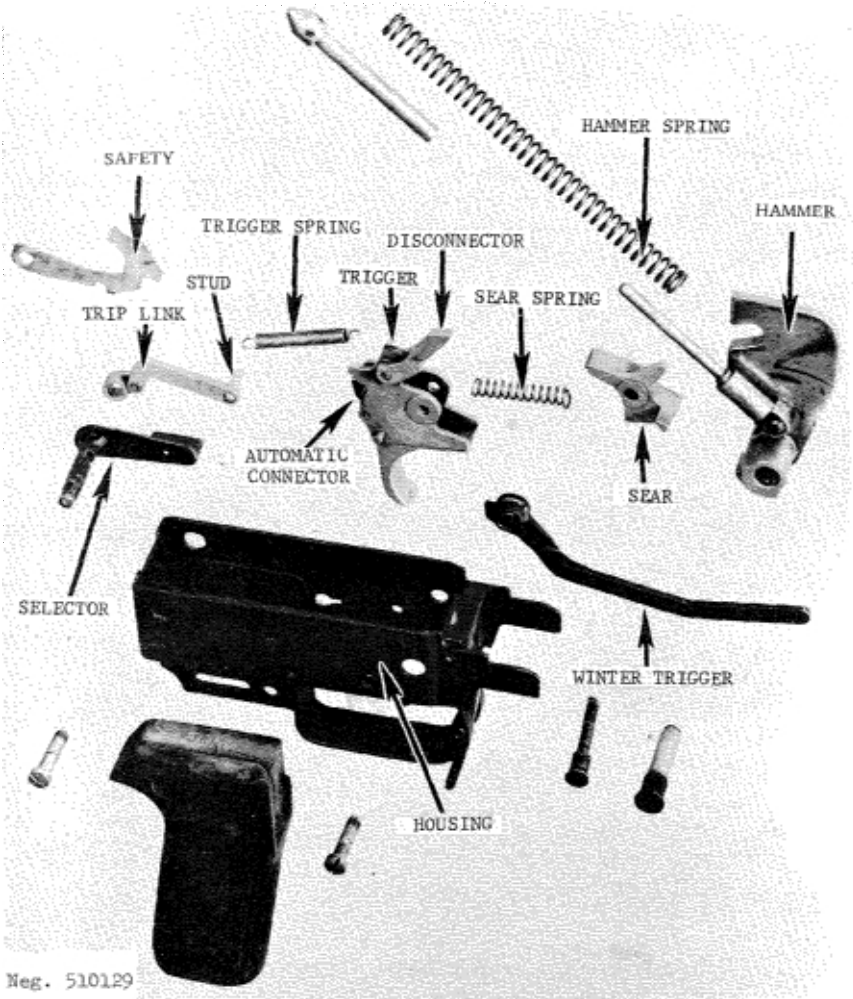

Figure 130. StG 57 trigger mechanism.

pivot. The normal recoil of the rifle upon firing gives sufficient momentum to the connector for it to move rearward against its weak spring, out from under the sear. When this occurs, the sear spring (fig 130) forces the sear back to its normal position where it can reengage the hammer, upon counterrecoil of the bolt. Thus, only one round is fired. To fire a second round, the trigger must

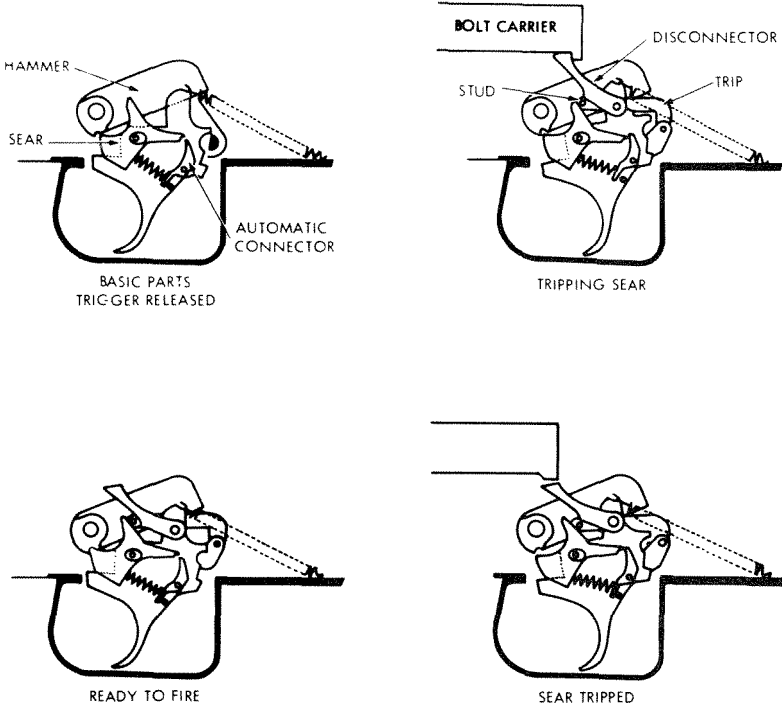

Fig. 511131

Figure 131. StG 57 trigger functioning.

be released; this lowers the connector so that it can spring under the rear of the sear. Trigger pressure will then start another cycle.

f. When the selector is moved to A for automatic fire, the trip link (fig 131), because of its joint, moves forward. This action causes the trip link stud (fig 130) to move along the top of the sear until it fits between the sear and the disconnector (fig 131). As the trigger is pressed the basic action in paragraph c above takes place to release the hammer; however, the position taken by the trip link stud now forces the disconnector to protrude into a slot in the bolt. This slot has a closed rear end and when the bolt counterrecoils, it strikes the disconnector and rocks it forward.

The forward movement is transmitted through the trip link stud to the sear (fig 131) and causes the sear to depress and release the hammer. This action continues as long as the trigger is pressed and cartridges are in the magazine. When the trigger is released, the disconnecter is lowered; this breaks the connection between the bolt and sear and firing stop.

g. When the selector is rotated to the safe position, a projection on the selector shaft fits into the trigger, stops trigger movement, and thus prevents firing.

h. The loaded chamber indicator is a small spring-loaded plunger that fits into the top rear end of the barrel. Normally the indicator is flush with the top of the receiver, but when the cartridge is chambered, the rear of the cartridge forces the indicator up, above the top surface of the receiver. The projecting indicator thus signifies that there is a cartridge in the chamber.

i. There is no last-round catch on the rifle.

167. Accessories

a. There are numerous accessories for the StG 57 and SIG 510 rifles, with some common to both rifles. Accessories include:

- (1) Telescopic sight.
- (2) Blank firing device.
- (3) Cleaning kit (carried in pistol grip).
- (4) Night sights.
- (5) Grenade sight (SIG 510).
- (6) Bayonet.

(7) Sling.

(8) Extra magazines.

b. The telescopic sight is attached by fitting it onto the pads on the receiver and rotating the lock levers on the scope base.

c. The bayonet is affixed by placing its ring over the muzzle while fitting the butt onto the bayonet stud until the bayonet locks in place. Remove the bayonet by pressing the large round catch on the butt and pull it forward off the rifle.

d. The cleaning kit consists of a weight and string pull-through with a bristle brush and a small clip to keep the chamber indicator out of the chamber. To use the clip, reach into the chamber and press the indicator; when it protrudes, slip the clip onto the groove in the indicator. The cleaning kit and night sights are carried in the pistol grip. To obtain them, insert the point of a bullet into the hole in the plate over the bottom of the pistol grip to slide the plate open.

e. The StG 57 and SIG 510 rifles can be used to launch 22-mm inside-diameter tube grenades. Only special blank grenade-launching cartridges can be used. The use of a bulletted round will cause the grenade to explode while still in place on the rifle!

f. A special grenade sight is available for the SIG 510 to be clamped onto the barrel jacket. For direct fire, use the sight in the manner described in paragraph 158f. For indirect fire set the angle for the range desired, and level the bubble. The StG 57 uses its normal front sight for direct fire, but only the Swiss UG 58 or HPzG 58 rifle grenades can be fired because the front sight is used, in conjunction with the ogive of the grenade, for aiming. The

bipod of the StG 58 is graduated for indirect fire. The bipod is opened, the rifle turned sideways and a weighed string attached to the bayonet lug. The string, when aligned with a mark on the bipod leg, sets the rifle at the correct angle for range.

J. THE 7.62-MM TYPE 64 RIFLE (JAPAN)

168. General

a. The 7.62-mm Type 64 rifle (fig 132) was developed in Japan. It is the standard rifle of the Japanese Ground Self-Defense Force but is used by no other country.

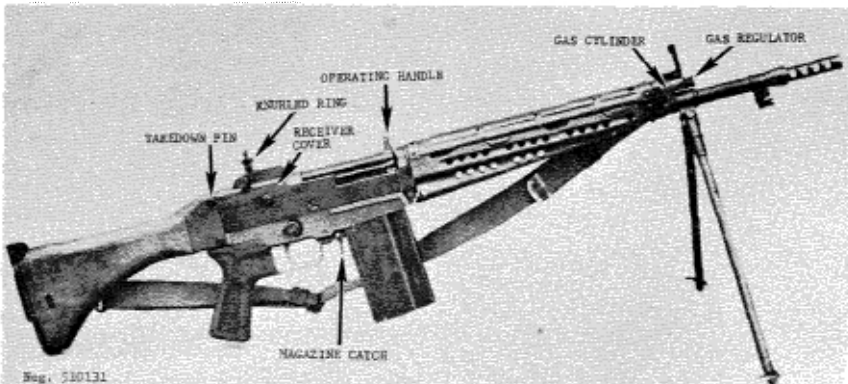

Figure 132. Japanese Type 64 rifle.

b. The Type 64 rifle, fairly conventional in appearance, can be identified by its odd-shaped butt stock, deep perforated forearm, and vertical operating handle.

c. The Type 64 rifle is a gas-operated, detachable box magazine-fed, selective-fire shoulder weapon equipped with a lightweight folding bipod and a hinged butt rest. A rotary gas regulator permits adjustments for various type cartridges.

d. The Type 64 rifle is chambered for 7.62x51-mm NATO ammunition (refer to sec V). The Japanese-preferred cartridge for the Type 64 rifle has a violet-colored bullet tip; this indicates that the cartridge is only 70% as powerful as the standard 7.62x51-mm NATO cartridge. The gas regulator must be adjusted to fire this round.

169. Technical Data

Technical data pertaining to the Type 64 rifle are presented in table III.

170. Operation

a. Load and insert the magazine as described in paragraph 128a and b. If the front and rear sights are folded, pull them up into firing position. Greatest accuracy is obtained with the bipod. To use it, pull the bipod legs forward until they snap into place. (Push the legs rearward to fold them.)

b. The gas regulator (fig 132) has three settings. The lower is used for firing full-powered 7.62-mm NATO cartridges; the mid setting is used for firing violet-tipped Japanese reduced-power cartridges, or to give increased power when firing 7.62 NATO cartridges in a fouled rifle. The upper setting is used when firing violet-tipped cartridges in a fouled rifle. Set the regulator by rotating it as necessary.

c. Adjust the rear sight for range by twisting the knurled ring on the rear sight (fig 132). Windage corrections can be made by rotating the windage knob.

d. Pull the operating handle (fig 132) fully rearward and release it. **CAUTION:** The rifle is now loaded and ready to fire. Pull out the selector and rotate it to the position desired (rearward

for safe, forward for semiautomatic, up for fully automatic). Aim (using a normal sight picture), and press the trigger. The rifle will fire according to the mode of fire selected. The bolt will remain closed between shots or bursts and when the last round is fired.

e. To unload or clear the Type 64, rotate the selector to its vertical or safe position, press the magazine catch (fig 132) toward the magazine and rock the magazine forward, out of the rifle. Pull the operating handle to the rear and inspect to insure that no cartridges are present. Release the operating handle, rotate the selector off safe, press the trigger and move the selector back on safe. Insert the magazine. If desired, fold the sights and bipod.

171. Disassembly and Assembly

a. Clear the rifle, but leave the hammer cocked and do not insert the magazine. Set the selector off safe and fold the bipod or sights.

b. Pull the takedown pin (fig 132) to the right, then lift up the rear end of the receiver cover (fig 132) until the cover comes off. Pull the driving spring out of the bolt carrier, then pull the carrier (fig 132) to the rear until it can be lifted out of the receiver. Lift the bolt out of the receiver.

c. No further disassembly is necessary or desirable.

d. To reassemble, first place the bolt onto the rear of the receiver with the leveled end up and to the rear. Place the bolt carrier over the bolt so that the cam on the bolt carrier mates with the cam cuts in the bolt. Move the carrier slightly back and forth until the carrier seats into the receiver. Push the bolt and carrier fully forward. Insert the driving spring into the bolt carrier.

e. Place the receiver cover onto the receiver so that the projections on the cover fit into their recesses in the receiver and the driving spring seats in the cover. Push the takedown pin back into place. Clear the weapon (para 170e).

172. Functioning

a. The Type 64 rifle is gas operated. When the weapon is fired, some of the propellant gases are tapped off through the gas port as the bullet passes the port and enters the gas cylinder (fig 132). The gases drive the piston rearward, and the rear end of the piston strikes the bolt carrier and drives it rearward. The piston's spring has been compressed and now returns the piston forward.

b. The piston's blow was sufficient to drive the carrier rearward, compressing the driving spring and driving the hammer back against its spring.

c. After a short free travel, the cam in the bolt carrier contacts the cam on the bolt and lifts the bolt up out of the locking recess, and both then move to the rear as a unit. This action is somewhat similar to that of the FN/F.A.L. (fig 84). The extractor holds the fired cartridge case to the bolt until the case strikes the ejector and is expelled. The bolt carrier finally hits the buffer in the back of the receiver and stops. The driving spring expands and drives the bolt carrier and bolt forward. The feed rib on the bolt drives the top cartridge out of the magazine and into the chamber. The bolt strikes the end of the barrel and stops; the bolt carrier continues forward and cams the bolt down into its locking recess. The extractor snaps into the groove of the cartridge, and the bolt carrier stops when it hits the front wall of the receiver.

d. When the hammer is cocked, it is caught by the sear. The hammer spring forces the sear forward on its elongated pin hole against the force of the sear spring and positions the front of the sear over the trigger.

e. In the semiautomatic mode, as the trigger is pressed, the rear end of the trigger rises under the sear and rotates the sear on its pin. The sear disengages from the hammer, which drives forward, under force of its spring, firing the rifle. Because the hammer no longer forces the sear forward, it moves rearward, under force of its spring, sufficiently to clear the hammer. As this happens, the sear raises to catch the hammer after it is driven rearward by the bolt recoil and then moves forward upon counterrecoil. The hammer forces the sear forward against the still-pressed trigger. To fire another round, the trigger must be released; as it is, the sear moves forward over it, and trigger pressure will then start the firing cycle again.

f. When the selector is turned to the automatic position, the automatic connector is raised, on the eccentric on the selector shaft, to the highest position. In this position, as the bolt carrier completes its forward movement, it contacts the automatic connector and makes it rotate on its shaft. The rear end of the automatic connector has a cam cut and, as the sear is forced forward by the recocked hammer, the sear rides up the cam and releases the hammer to fire another round. This action continues as long as the trigger is pressed and ammunition is present. When the trigger is released, it allows the sear to move to the rear and hold the hammer cocked.

g. When the selector is moved to the safe position, the automatic connector is moved rearward and forces the sear rearward to a point where the trigger cannot contact it; thus the rifle cannot be fired.

173. Accessories

The Type 64 rifle has a knife bayonet and a web sling as standard accessories. A plastic muzzle cover, magazine cover, and magazine well insert are used to prevent fouling of the rifle.

K. THE 7.5-MM FR-F1 SNIPER'S RIFLE (FRANCE)

174. General

a. The FR-F1 sniper's rifle (fig 133 and 134) is one of the newest weapons of the French Army. This extremely accurate weapon has been designed especially for use by snipers. The primary sighting equipment is a 3.8-power telescopic sight, and nonadjustable 100-meter open sights, with a self-contained

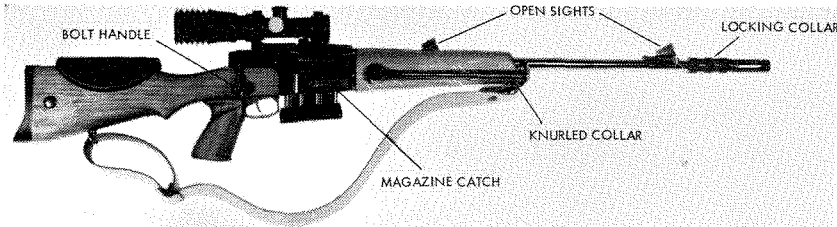

Figure 133. French FR-F1 sniper's rifle.

luminous feature, are provided for aiming under adverse light or emergency conditions. The designation FR-F1 is the abbreviation for Fusil a Repetition Modele F1, i.e., Repeating Rifle Model F1. The sole producer of this weapon, which is used only by the French Army, is the Manufacture Nationale d'Armes de St. Etienne, St. Etienne, France. The FR-F1 sniper's rifle is a manually operated, bolt-action repeating rifle fed from a detachable, 10-round box magazine. The breech mechanism of the FR-F1 is similar to that of the now obsolete French 7.5-mm Model 1936 rifle (para 180) and, although the FR-F1 is a new

3 February 1984

weapon, some parts (firing pin, firing pin spring, bolt plug, extractor, sear, bolt stop, and sear spring) can be interchanged between the two weapons. A bayonet cannot be affixed to the FR-F1 sniper's rifle, nor can it be used to launch grenades.



Neg. 510133

Figure 134. FR-F1, Left Side View

b. The FR-F1 rifle is produced in three versions: (1) Tireur d'Elite (sniper), the subject of this section; (2) Tir Sportif (target rifle), which has target-type metallic front and rear sights, and a 3.3- to 4.2-pound trigger pull; and (3) Grande Chasse (hunting rifle), which has an APX Model 804 telescopic sight and a 4.5- to 5.5-pound trigger pull. Only the sniper's rifle is equipped with a bipod.

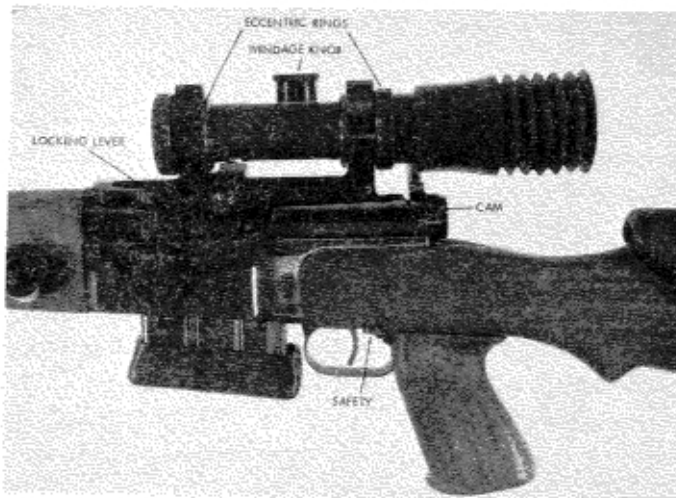

Neg. 510134

Figure 135. APX 804 Telescopic Sight

3 February 1984

★ c. The FR-F1 sniper's rifle normally will fire the French standard 7.5x54-mm cartridge; but another FR-F1 version will fire the 7.62x51-mm NATO cartridge. Only ball ammunition, preferably of match quality, should be fired; the use of armor-piercing or tracer ammunition will ruin the accuracy of the rifle. The caliber designation, 7.5-mm or 7.62-mm, is inscribed on the left wall of the receiver; only use the appropriate cartridge.

175. Technical Data

Technical data concerning the FR-F1 sniper's rifle will be found in table V.

176. Operation

a. After removing the telescope from its carrying case, mount the telescope on the rifle by mating the two claws on the right of the mount with the undercuts on the two dovetail pads on top of the receiver. The single lug on the left side of the mount must align with the slot between the two pads, and the locking lever (fig 135) must point rearward. Rock the telescope to the left, slide it forward until it stops, and swing the locking lever fully forward.

b. Remove the magazine by pressing the magazine catch (fig 133) and catching the magazine as it ejects. Place a cartridge on the magazine platform and press the cartridge into the magazine until it rolls sideward under the magazine lip. Repeat until the magazine is full. (The rubber cap can be removed from the bottom of the magazine and used as a dust cap over the top of the loaded magazines. The cap must be removed and replaced on the magazine's bottom before loading the magazine into the rifle.) Insert the loaded magazine into the opening in the receiver until

magazine catch snaps into place and retains the magazine. A partially expended magazine can be reloaded by pressing cartridges into it while it is in the rifle; this operation is awkward, however.

c. The bipod gives maximum stability while firing and should normally be used. Place the fingers under the forearm and, with the thumb on the knurled collar of the bipod, press hard on the bipod leg until it swings down; then pull it rearward until the leg clicks into place. The legs can be extended by twisting the knurled collar in the direction of the arrow inscribed on the collar; the spring-loaded lower legs will extend automatically. Twist the collar back to its original position to lock the legs at the desired height.

d. To prepare the rifle for firing, lift up the bolt handle (fig 133), pull it fully rearward, then thrust it forward and turn it down. CAUTION: The rifle is now ready to fire. To render the rifle safe, swing the safety down behind the trigger (fig 134). To fire: (1) swing the safety to the left, (2) aim (fig 136), and (3) press the trigger. To reload: (1) lift up the bolt handle, (2) pull it vigorously rearward, and (3) thrust forward and turn it down. The rifle is now ready to fire another shot. When the last cartridge in a magazine is fired, the bolt is blocked after it is drawn rearward and cannot be thrust forward until the magazine is removed or refilled.

e. Under adverse light, it may be necessary to use the open sights. Remove the telescope by rotating the lock lever rearward, and then pulling the telescope rearward until it disengages from the receiver. Replace the telescope in its carrying case. Flip up the open front and rear sights (fig 133). The sight picture to be used during the daytime is the same as that for the US M1911A1 pistol. At night, a green luminous dot on the front sight and two horizontally aligned red dots on the rear sight will glow; align and

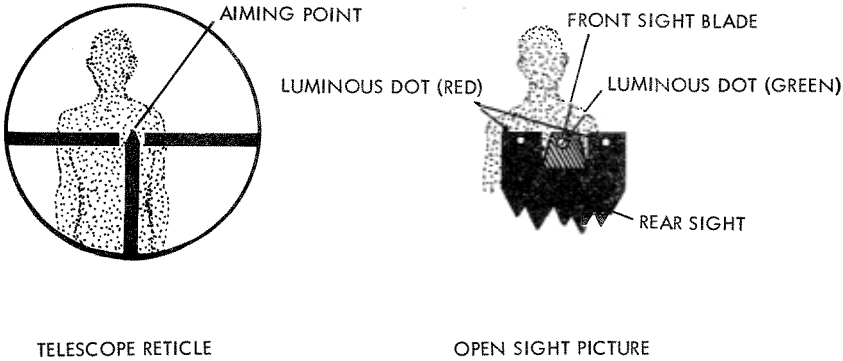

Figure 136. Sight picture.

evenly space all three dots, green in the center, and superimpose them on the target (fig 136).

f. To clear the rifle, first set the safety on safe, then press the magazine catch and remove the magazine. Open the bolt, inspect to insure that no cartridges are present, then close the bolt. Swing the safety to the side, press the trigger and reset the safety to safe. If there are cartridges in the magazine, press them forward out of the magazine, then insert the magazine back into the rifle.

177. Disassembly and Assembly

a. To disassemble the FR-F1 rifle for cleaning, clear the rifle (para 176f), but do not reset the safety to safe or replace the magazine. Remove the cheek pad (para 176f), open the bolt, pull the trigger fully rearward and, while holding the trigger, remove the bolt (fig 137).

b. Firmly press in the plug at the rear of the bolt; turn the plug clockwise until the letter D aligns with the index line on the

bolt. CAUTION: The strong firing spring will be released; keep parts under control. Remove the plug, firing spring, and firing pin. The extractor should be removed only when necessary for replacement. Push the claw end of the extractor away from the bolt until the extractor can be pried forward and freed.



Figure 137. FR-F1 bolt removal.

c. To reassemble, replace the extractor by pushing its tail into the undercut on the side of the bolt as far as possible. Push the front of the extractor outward until the round stud clears the bolt, then fully seat the extractor. Slide the firing pin into the bolt so that the lug on the firing pin is in line with the flat surface on the bottom of the bolt. Insert the firing spring and plug into the bolt and align the "D" in the plug with the index line on the bolt. Force the plug into the bolt and then turn it counterclockwise as far as possible.

d. Pull the trigger and insert the assembled bolt into the receiver, twisting as necessary, until it goes forward. Release the

trigger, turn the bolt handle down, press the trigger, and move the safety to the safe position. Insert the magazine.

e. To install the cheek pad, choose the one with the desired height, either 8- or 17-mm, align the pins on the underside of the pad with the holes in the comb of the stock and force the pins into the holes. It may be necessary to use a soft mallet to seat the pad. The pad is removed by gently prying up on the ends until it comes free. The pad must be removed before the bolt can be extracted from the rifle.

f. Two wood spacers issued with the FR-F1 rifle are used to lengthen the stock to suit the individual shooter. These are 20 and 40 millimeters thick and are installed by removing the screw in the butt plate, removing the butt plate and inserting the spacer, then replacing the butt plate and butt plate screw. Be sure that the spacer is aligned with the stock and not installed in an inverted position.

g. The trigger mechanism has adjustments for length and weight of pull; however, these adjustments should be made by competent armorer.

h. The adjustment of the flash suppressor is extremely critical in obtaining maximum accuracy; avoid altering the factory setting by turning the flash suppressor or its locking collar. If the flash suppressor has been removed or replaced, the barrel assembly must be returned. Loosen the locking collar (fig 133) as far as possible and, using a broad wooden bar inserted through the slots in the flash suppressor, screw the suppressor fully onto the barrel. Hand-tighten the collar and fire a five-shot group. Loosen the collar and unscrew the suppressor two turns, retighten the collar, then fire another five-shot group. Repeat until the smallest radius shot pattern is achieved, then use one-half-turn increments and repeat the firing. When the smallest group is achieved, use a strap wrench to tighten the collar.

178. Functioning

a. The FR-F1 rifle is manually operated. All energy to remove the fired cartridge and replace it with a fresh one is supplied by the shooter's manipulation of the bolt. As the bolt handle is turned upward, a camming action between the bolt and the firing pin retracts the firing pin point and compresses the firing spring. Concurrently, a cam at the root of the bolt handle bears against a cam surface at the left rear of the receiver (fig 135), providing slow initial extraction (if necessary) to break a sticking cartridge case loose from the chamber. The locking lugs on the bolt also rotate out of their seats in the receiver.

b. As the bolt is drawn rearward, the extractor removes the cartridge case from the chamber and holds it against the bolt face until the stationary ejector (located well behind the magazine at the left rear) expels the cartridge case. As the bolt is drawn rearward, the bolt stops, under pressure of its spring, and rides against the flat surface on the bottom of the bolt; this stop, in conjunction with the ejector protruding into its slot in the bolt, prevents rotary motion of the bolt as it moves back and forth. A shoulder on the bottom front of the bolt finally strikes the bolt stop to limit rearward travel of the bolt.

c. The magazine spring forces a fresh cartridge into position in the feed lips, and, as the bolt is pushed forward, it forces a cartridge from the magazine into the chamber. The bolt is locked by turning the bolt handle down; as this happens, the extractor snaps over the rim of the cartridge, and the sear intercepts the firing pin lug, holding the firing pin cocked.

d. When the trigger is pressed, it swings to the rear on the tripper pin (which joins the trigger and sear) until the trigger stud contacts the bottom of the receiver. Further movement of the

trigger, transmitted through the tripper pin, causes the sear to pivot on the sear pin and to compress the sear spring. Finally, the top of the trigger adjusting screw contacts the receiver and causes a definite stop; any further movement of the sear requires a heavier pull on the trigger, and this in turn will release the firing pin and fire the rifle.

e. The bolt stop also pivots on the trigger pin. When the trigger is pulled fully rearward, a shoulder on the top of the trigger strikes the bolt stop and forces it to pivot downward against the pressure of a separate spring. The bolt stop moves down sufficiently so that it cannot contact the stop surface in the bolt, and the bolt then can be pulled out of the rifle.

179. Accessories

a. The FR-F1 sniper's rifle is issued with a complete set of accessories. The set includes:

- (1) An extra magazine.
- (2) Two stock extensions of different lengths (20- and 40-mm).
- (3) Two cheek pads of different height (8- and 17-mm).
- (4) A Modele 53 bis telescope with its carrying case and adjustment tool.
- (5) A spare firing pin spring.
- (6) A standard French issue leather sling.
- (7) A leather cleaning case with two pull-through thongs.

The above listed accessories are packed, along with an instruction manual, in a sturdy wood chest used for storing and shipping an FR-F1 sniper's rifle.

b. The pull-through thongs can be used for cleaning the barrel. One thong should be left dry, the other lightly oiled. The oiled thong should be enclosed in a plastic bag to preclude transfer of oil to the dry thong. Point the muzzle down; drop the weight into the chamber and allow the weight to fall out of the muzzle. Grasp the weight and pull the thong through the barrel. The use of these thongs is not recommended except as a last resort, when a conventional cleaning rod is not available.

c. The M53 bis telescope can be zeroed to the rifle's point of impact. The eccentric plastic rings between the telescope and the mount rings provide a means of coarse adjustment; final, fine adjustments can be made on the windage and elevation knobs. Install the telescope on the rifle (para 176a), remove the rifle's bolt (para 177a), loosen the screws at the bottom of the mount rings, set the elevation knob at 2, and set the red line on the windage knob (fig 135) to its index. Select an aiming point at least 200 meters distant and, sighting through the barrel, center the various concentric rings in the barrel on the aiming point. If the point of the reticle does not coincide with the aiming point, rotate one or both of the plastic rings until the reticle does coincide. Recheck to insure the barrel is still aligned with the aiming point. If it is, tighten the screws on the mount rings. The FR-F1 rifle should now be fired, at 200 meters range, to provide three-shot groups. If the point of the reticle does not coincide with the point of impact of the bullets, loosen the three lock screws on the elevation knob. The adjustment tool, carried in the telescope carrying case, is used to loosen the screws. Rotate the windage knob and, using the spanner end of the adjustment tool, rotate the elevation zero ring until the point of the reticle and the point of

impact of the bullet coincide. Hold the zero ring stationary with the spanner and turn the elevation knob until the figure 2 aligns with the index. Tighten the three screws on the elevation knob. Loosen the three screws on the windage knob and rotate the knob until its red line is aligned with the index; then tighten the three screws. The rifle should be fired again to insure no changes occurred while the final adjustments were being made.

L. THE 7.5-MM MODEL 1936 RIFLE (MAS-36) (FRANCE)

180. General

a. The French Model 1936 rifle (MAS-36), although obsolete in the French Army, is widely used by the armies of many of the old French colonies and protectorates. Captured weapons are often used by irregular or guerrilla forces. The manually operated MAS-36, while somewhat crude in construction and appearance, is an extremely simple and rugged rifle. It is readily identified by its odd, swept-forward bolt handle, two-piece stock, and spike bayonet.

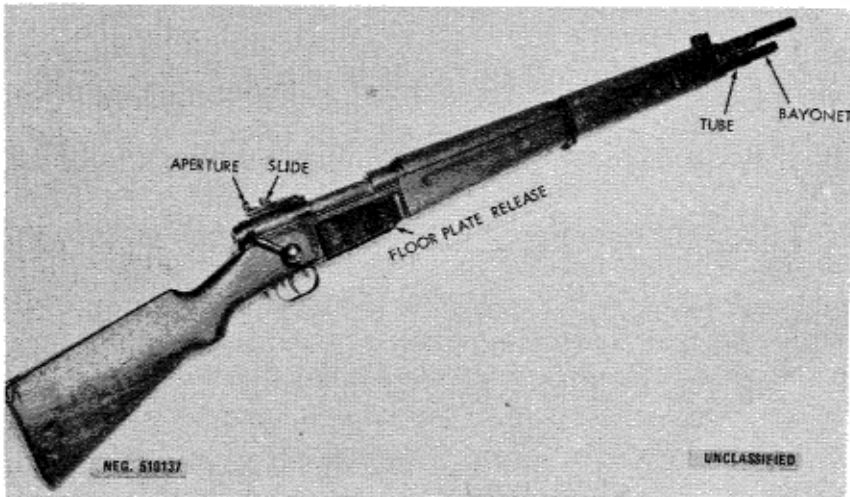

Figure 138. French M.A.S. 36 rifle.

b. The latest version, the Model 36/51 rifle has a grenade launcher system similar to that on the Model 49 rifle (para 156). An older model, the MAS-36 CR39, has a folding metal stock. This weapon is for use by paratroops and is rarely encountered today. The MAS-36 fires only French 7.5x54-mm cartridges (sec V).

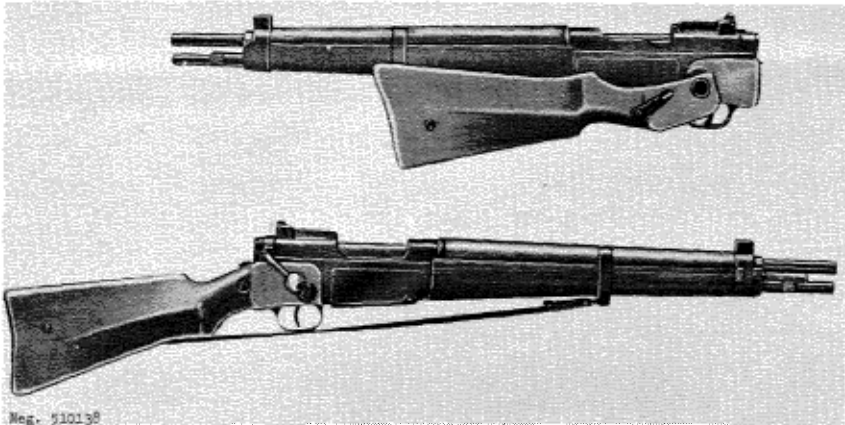

Figure 139. French M.A.S. 36 CR 39 rifle.

181. Technical Data

Technical data concerning the MAS-36 rifle are given in table V.

182. Operation

a. The MAS-36 is operated in the same manner as the FR-F1 rifle (para 176). The easiest way to unload this rifle is to open the bolt and, after catching the ejected cartridge, leave the bolt open. Squeeze in the floor plate release (fig 138) and open the floor plate; the cartridges will fall out of the magazine.

b. Set the rear sight for the desired range by depressing the aperture (fig 138) and moving the slide until it is aligned with the

graduation corresponding to the range in hundreds of meters. Release the aperture.

c. The bayonet is carried reversed in the forestock. Press the catch on the bayonet, withdraw it, and after reversing it, slide the bayonet's butt back into the tube. The catch will retain it. Remove the bayonet by pressing the catch and pulling the bayonet out of the tube.

183. Disassembly and Assembly

a. To disassemble the rifle, clear the weapon by opening the bolt and the floor plate (para 182a).

b. Pull the trigger and, while holding it, draw the bolt out of the receiver.

c. No further disassembly is required or desirable.

d. To reassemble the weapon, start the bolt into the receiver, turn it as necessary, and push it home; then insert the follower and spring into the magazine opening and close the floor plate.

184. Functioning

a. The MAS-36 rifle is manually operated. As the bolt handle is turned up to unlock the bolt, a camming action between the end of the bolt and firing pin forces the firing pin rearward and compresses the firing spring. A cam surface at the root of the bolt handle bears against a cam surface on the left rear of the receiver; this provides initial extraction.

b. The extractor holds the cartridge case to the bolt and thus extracts the case from the chamber. When the bolt is drawn

fully rearward, the ejector expels the fired case. Meanwhile, the magazine spring has moved a fresh cartridge into position in front of the bolt.

c. When the bolt is thrust forward, it pushes the cartridge out of the magazine and into the barrel. The bolt is rotated to reseat the locking lugs, and the extractor snaps over the rim of the cartridge.

d. The MAS-36 has no manual safety; however, if the bolt is not fully locked and the interaction between the cam on the rear of the bolt and the firing pin lug will close the bolt or prevent the firing pin from striking the cartridge.

e. While slightly different in detail, the MAS-36 trigger mechanism is essentially similar to that of the FR-F1 rifle (para 178d).

185. Accessories

The MAS-36 has a spike bayonet housed in its forestock. A web sling is used to carry the rifle.

M. THE .303-CALIBER (7.7-MM) LEE ENFIELD RIFLES (UK)

186. General

a. The .303-caliber (7.7-mm), manually-operated Lee Enfield rifle has been made in many different models; figure 140 depicts the more common varieties. The prominent magazine is a prime recognition feature for all Lee Enfields, and the older No. 1 rifle (fig 140) can be recognized by its snub-nosed muzzle. A sniper version of the No. 4 equipped with a telescope (fig 140) was issued, and a lightened version with a shortened forestock, the No. 5 (fig 140), was designed for jungle warfare. The various models of

The Lee Enfield, while differing in appearance, are generally similar in operation, disassembly, and functioning; differences will be noted as necessary. Postwar modifications resulted in a No. 4 Mark 2 rifle; this was the same as No. 4 Mark 1, except that the trigger was pinned to the receiver. The No. 4 Mark 1 and Mark 1* rifles were modified to No. 4 Mark 2 standards; these are known as No. 4 Mark 1/2 or Mark 1/3, respectively.

b. The Lee Enfield was manufactured in Great Britain, Australia, India, Canada, and the United States; the latter often bears a "US Property" mark that indicates a World War II Lend-Lease weapon. Occasional crude copies made in small Indian village shops will be found; under no circumstances should these homemade weapons be fired. The regular Indian rifles, marked "Ishapore" or "IA," are safe to use.

c. The British have converted some No. 4 series Lee Enfields to fire 7.62x51-mm ammunition. This conversion includes the installation of a new precision-made barrel, a new bolt head (stamped 19T), a new extractor, a clip guide liner to permit use of NATO clips, and a new magazine which incorporates the ejector and removal of the old ejector screw. The fore stocks and hand guard have also been shortened. These 7.62-mm rifles exist in two versions, the L37 and the L42. The L37 is a competitive target rifle based on the No. 4 Mk2 or Mk1/2 or MK1/3 mechanism and fitted with precision metallic sights. The L42, the current standard British snipers' rifle, is based on the No. 4 Mark 1T snipers' rifles. Some No. 4 Jungle carbines have also been converted to 7.62x51-mm, but their recoil is quite severe.

d. The Indian Army has converted its No. 4 and some No. 1 series Lee Enfields to 7.62x51-mm.

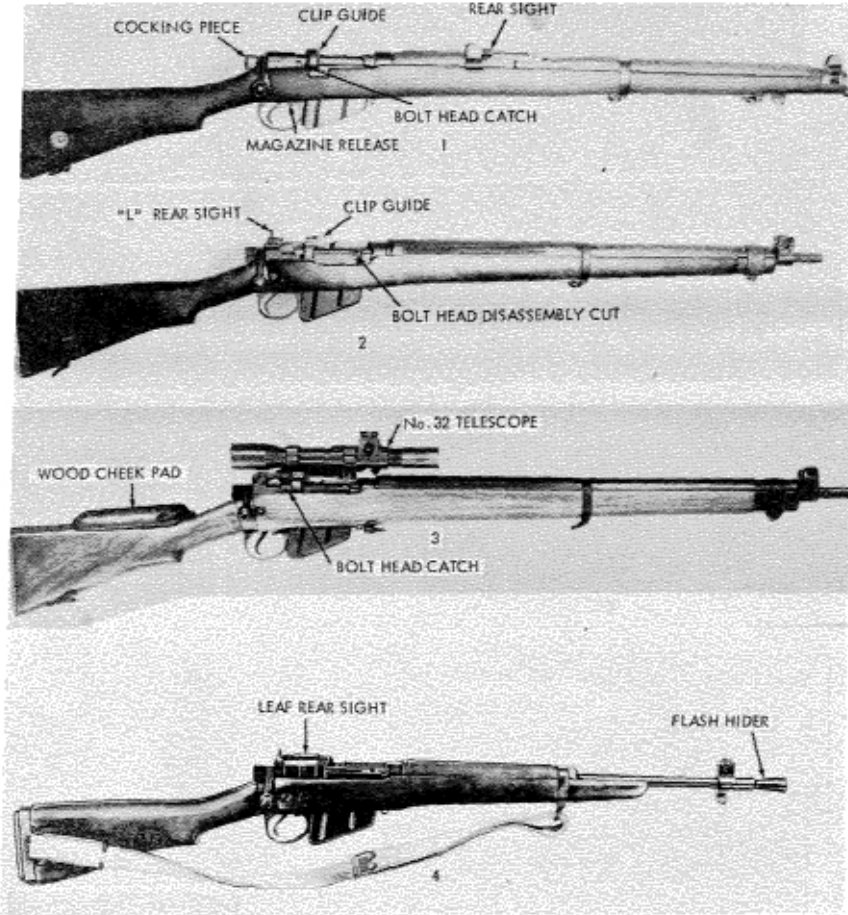

Figure 140. Lee Enfield rifles.

e. Refer to section V for information concerning ammunition fired in Lee Enfield rifles.

187. Technical Data

Technical data concerning the Lee Enfield rifles are given in table V.

188. Operation

a. Open the bolt by turning the bolt handle upward as far as possible; then pull the bolt fully rearward.

b. Load the rifle. Any of the following methods can be used.

(1) If clipped ammunition is available, insert the clip into the clip guides (fig 140), and with the thumb as close as possible to the clip, press the cartridges into the magazine. Remove the clip and repeat this action with a second clip so that 10 rounds are loaded into the magazine. When loading loose cartridges into empty clips, insure that the rims of the cartridges in the middle and on the ends are below the rims of the other two cartridges.

(2) Loose cartridges can be individually pressed into the magazine to insure that the rim of each cartridge is in front of the rim of the round that preceded it.

(3) Individual cartridges can be directly inserted into the chamber.

c. When the rifle is loaded, shove the bolt fully forward (spring resistance will be felt during approximately the last inch of travel) and turn the handle down. CAUTION: The rifle is loaded and ready to fire.

d. If the rifle is not to be fired immediately, render it safe by rotating the safety at the left rear of the receiver fully to the rear. This locks the firing pin and bolt. An alternate method is to grasp the cocking piece (fig 140) firmly, pull it to the rear, and after pressing the trigger, ease the cocking piece forward. Release the trigger and bring the cocking piece to rest at the half cock position. This procedure is not recommended.

e. Set the sights for the desired range according to the rifle model:

(1) If the rifle is a No. 1, press the slide locks on the rear sight (fig 140), and move the slide along the leaf until the index mark on the slide lines up with the number on the leaf that corresponds with the range in hundreds of yards. Final fire adjustments can be made by rotating the worm screw on the slide.

(2) If the rifle is an early No. 4 with an L rear sight (fig 140), flip the sight to the desired range (300 or 600 yards). The 300-yard aperture is used for firing at 400 yards if the bayonet is attached.

(3) If the rifle is a No. 4 with an adjustable rear sight or a No. 5 carbine (fig 140), lift the leaf and move the slide along it until the index mark is aligned with the number denoting the range in hundreds of yards. The slide is moved either by pressing a catch on the slide or by turning an adjusting screw at the top of the slide, depending on the model of the sight. The fixed large battle aperture can be used when the sight is folded down; this is set for about a 300-yard range. By aiming at a man's chest with this sight, a hit should be scored on some part of his body at any range up to 300 yards. The sniper rifles do not have the battle aperture.

(4) The No. 32 telescope is used on the No. 4 Mark 1T; with minor changes, it is also used on the L42 sniper's rifle. The telescope is set for range and deflection by rotating its knobs, and the elevation knob at top is marked to indicate hundreds of yards.

f. To fire these weapons, rotate the safety forward (or pull the cocking piece fully rearward) and (using a conventional sight

picture) aim, and squeeze the trigger. The rifle will fire one shot. To reload, turn the bolt handle up, pull it fully and briskly rearward, thrust it forward, and turn it down. The rifle is now ready for another shot. When the last round is fired, the bolt is not caught to the rear.

g. To unload or clear the rifle, press the magazine release (fig 140) and remove the magazine. Open the bolt and catch any ejected cartridge. Push any remaining cartridges forward, out of the magazine, and insert the empty magazine into the rifle, striking it with the heel of the hand to insure that it is fully seated. Close the bolt and press the trigger.

189. Disassembly and Assembly

a. To disassemble the Lee Enfield:

(1) Clear the rifle (para 188g), but do not insert the magazine.

(2) Remove the bolt.

(a) If it is a No. 1 rifle, open the bolt and draw it fully to the rear; then press up on the bolt head until it is released by the bolt head catch (fig 140) and the head is vertical. This requires considerable force. Pull the bolt rearward out of the receiver.

(b) If it is a No. 4 Mark 1*, MK1/3 or L37, open the bolt and draw it slightly to the rear until the bolt head is aligned with the disassembly cut in the receiver (fig 140). Turn the bolt head up and, after lifting the rear sight to its vertical position, pull the bolt out of the receiver.

(c) If it is a No. 4 Mk1, MK2, MK1/2, sniper rifle, No. 5 carbine, or L42, open the bolt, depress the bolt catch

(fig 140), and pull the bolt fully rearward (holding the catch depressed). Turn the bolt head to a vertical position and, after lifting the rear sight, pull the bolt to the rear out of the rifle.

b. To reassemble the rifle, insure that the bolt head is screwed into the bolt as far as possible; then back it off until it is in line with the guide rib of the bolt. Insert the bolt into the receiver; the rear sight leaf of the No. 4 and No. 5 rifles must be vertical. When the bolt head is just forward of the shoulder, turn the head down. If the rifle is a No. 4 Mk1*, MK1/3, or L37 press the bolt forward until the bolt head is aligned with the cut (fig 140) in the receiver; seat the bolt head into this cut and close the bolt. For all other rifles, as soon as the bolt head clears the shoulder, press it down, against the spring catch, until the bolt can be pushed forward. Reinsert the magazine (para 188g).

190. Functioning

a. The Lee Enfields are manually operated, and the basic bolt functioning is similar to that of the FR-F1 (para 178); however, the cam on the bolt merely retracts the firing pin point into the bolt and does not fully compress the firing spring. This spring is compressed by the shooter as he forces the bolt forward in its last inch or so of travel.

b. The extractor pulls the fired cartridge out of the chamber and holds it to the bolt face. At the same time, however, the extractor also forces the rim of the cartridge hard against the inner left wall of the receiver; the friction is usually sufficient to cause the cartridge, when clear of the chamber, to pivot about the extractor and to be expelled. If the extractor spring is weak, a small screw protruding into the receiver insures that ejection takes place by stopping the cartridge and making it pivot about the extractor. However, on the L37 and L42 rifles, a lip on the magazine performs this function.

c. The safety performs two functions, locking both the bolt and the cocking piece. When the safety is rotated rearward, a steep pitch multiple thread moves a small lug inward and into the bolt. This prevents the bolt from being rotated. A sector of the safety shaft concurrently meshes with the cocking piece, forces it rearward, and locks it in place.

d. The sear is an L-shaped component, one arm of which projects in front of the cocking piece to hold it in the cocked position. The other arm extends downward in front of the trigger. The upper end of the trigger has two humps; these act in the same fashion as do the humps on the FR-F1 (para 178).

191. Accessories

a. Several different styles of bayonets are used, according to the model of the rifle. The No. 1 rifles use a long sword bayonet; the No. 5 carbine uses a Bowie knife-type of bayonet. These are affixed and removed in the same manner as the Mauser 1898 bayonet (para 59a). The No. 4 rifles use an odd, handleless, short bayonet with either a spike or blade. These bayonets are affixed by placing their loop over the muzzle, forcing them back, and twisting until locked in place. The bayonet is removed by pressing in the knurled lock at its rear end and twisting and pulling it off the muzzle.

b. A web sling is invariably used with this rifle. Miscellaneous accessories such as breech covers, pull through strings (used for cleaning in lieu of a cleaning rod), and oil bottles (carried in the butt trap) are usually found with these rifles.

N. MISCELLANEOUS RIFLES

191.1. General

In addition to the rifles previously covered, there are a few rifles that because of their relative newness or limited distribution do not warrant full coverage in this guide and thus are presented for identification only.

191.2. The French 5.56 F.A.M.A.S. Rifle

The F.A.M.A.S. rifle (fig 140.1) was recently adopted by the French Army as their standard rifle. This rifle fires 5.56x45-mm ammunition and is capable of firing either fully or semiautomatically. The muzzle attachment permits firing 22-mm tubed rifle grenades. The F.A.M.A.S. can be recognized by its unique shape; in fact the French have nicknamed this weapon the "Clarion" (Bugle) because of its shape.

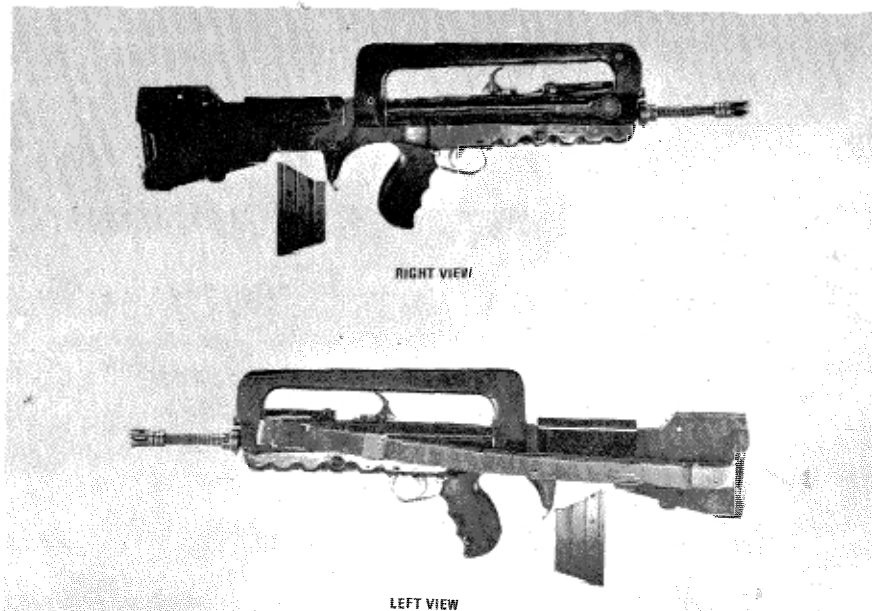

Figure 140.1. The French F.A.M.A.S. rifle.
238.1

191.3. The West German H&K SSG Sniper's Rifle

The SSG is based on the well-known G-3 rifle (para 144) but differs in that the SSG has been selected for its accuracy and has been fitted with an excellent varipower Zeiss telescope sight (fig 140.2). A pad has been added to the stock to enable sighting without strain, and a special set-trigger has been incorporated into the trigger mechanism. When the weapon is loaded and ready to fire, the projection immediately behind the trigger is pressed in as far as possible to cock the set mechanism. When this is done, the trigger will release the hammer upon the application of approximately 0.25-kilogram pressure. The SSG is used by the West German Army and police forces.

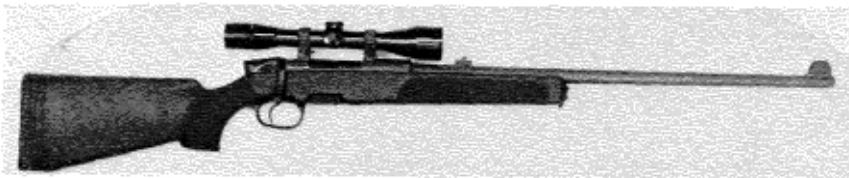

Figure 140.2. The West German H&K SSG sniper's rifle.

191.4. The Austrian Steyr 7.62-mm SSG Sniper's Rifle

The Austrian Steyr SSG Sniper's rifle (fig 140.3) is a military version of the world famous Steyr Mannlicher sporting rifle. The SSG is in service with the Austrian Army and, because it is offered for commercial sales, may be found in use by other nation's armed forces. The SSG is equipped with a

ZF691A telescope sight and has simple open sights on the barrel for emergency use. The SSG fires 7.62x51-mm (NATO) ammunition; for best performance, match or target grade ammunition should be used. The SSG can be readily identified by its green plastic sporter-type stock, spoon-handle-shaped bolt handle, and flush detachable magazine, located in front of the trigger guard.



Neg. 529276

Figure 140.3. Austrian 7.62-mm Steyr SSG
Sniper's Rifle

191.5. The Belgium 5.56-mm FNC Assault Rifle

The 5.56-mm FNC assault rifle (fig 140.4 and 140.5) is the latest military weapon offered by the Belgium Fabrique Nationale concern. The FNC will eventually replace the C.A.L. (para 114). The FNC, which fires 5.56x45-mm ammunition, can be identified by its slab-sided receiver, tubular folding stock, and heavy ribbed forearm.

February 1984



eg. 524785

Figure 140.4. The Belgium 5.56-mm FNC Assault Rifle, Stock Extended



eg. 524786

Figure 140.5. The Belgium FNC Assault Rifle, Stock Folded

Table V. Rifle Technical Data

Weapon	C.A.L.	HK 33 or 53	FN/FAL	GALIL	Beretta M70/.223	AUG ⁷	G3	BM59 MK ITAL	M49/56	St.G. 57	Type 64	FR-F1	MAS 36	LEE ENFIELD	
Caliber (mm)	5.56x45	5.56x45	7.62x51	5.56x45	5.56x45	5.56x45	7.62x51	7.62x51	7.5x54	7.5x55.5	7.62x51	7.5x54 or 7.62x51	7.5x54	.303 .77x56R	
Length (mm)	980	920 ¹	1100	979 ⁴	940	790	1020	1095	1010 ⁵	1100	930	1163	1020	1130	
Weight, empty (kg)	3.4	3.45 ²	4.3	4.3	3.4	3.6	4.3	4.2	4.1 ⁵	5.7	4.7	5.1	3.76	4.1	
Barrel length (mm)	465	390	533	460	450	508	450	490	520 ⁵	690	450	600	575	641	
Magazine capacity (rd)	20 or 30	20 or 40	20	35 or 50	30	30	20	20	10	24	20	10	5	10	
Operation	Gas	Delayed blowback	Gas	Gas	Gas	Gas	Delayed blowback	Gas	Gas	Delayed blowback	Gas	Manual	Manual	Manual	
Fire-type	Selective	Selective	Selective	Selective	Selective	Selective	Selective	Selective	Semi-automatic	Selective	Selective	Repeating	Repeating	Repeating	
Locking feature	Rotary bolt	Roller	Tilting bolt	Rotary bolt	Rotary bolt	Rotary bolt	Roller	Rotary bolt	Tilting bolt	Roller	Tilting bolt	Rotary bolt	Rotary bolt	Rotary bolt	
Muzzle velocity (m/s)	965	960	840	980	970	970	800	800	820 ⁵	750	710 ⁶	860 (7.62x51)	850	745	
Practical range, semiautomatic (m)	400	400	600	400	400	400	400	600	500	500	500	600	500	550	
Rate of fire:															
Cyclic (rd/min)	700	600	650-700	650	630	680-850	550	810	DNA	450-600	450	10-15	15	15-20	
Semiautomatic (rd/min)	60-80 ³	60	60	60	60	60	60	60	35-40	60	60	DNA	DNA	DNA	
Method of loading	Detachable magazine	Detachable magazine	Detachable magazine	Reloadable magazine	Detachable magazine	Detachable magazine	Detachable magazine	Detachable magazine	Detachable magazine	Detachable magazine	Detachable magazine	Detachable magazine	Internal magazine	Internal magazine (detachable)	
¹ Stock folded: 750 mm		⁵ M49													
² With folding metal stock: 3.62 kg		⁶ With Japanese violet tip ammo, see para 168.D													
³ Using three-round bursts		⁷ All data is for the assault rifle version, see para 143.1													
⁴ 742 with stock folded		⁸ 407-mm and 610-mm barrels are also available													

O. MAINTENANCE

192. Care and Cleaning

The procedures and materials prescribed for cleaning standard US Army rifles also apply to free world rifles. These weapons should be disassembled only to the extent necessary for adequate cleaning in order to prevent breakage and subsequent loss of use. No repairs other than replacement of parts should be attempted on foreign rifles, and this should be done only by a competent armorer.

193. Malfunctions and Stoppages

See table VI for common malfunctions and their remedies. Malfunctions caused by broken or worn parts can be corrected by replacing the defective part with a serviceable one. This should be done only by a competent armorer, and the repaired weapon must then be function test fired.

Table VI. Rifle Malfunctions

Condition	Cause	Remedy
Fails to fire (cartridge in chamber)	Defective cartridge	Reload
	Bolt not fully locked	Clean and lubricate
Fails to fire (no cartridge in chamber)	Short recoil	Clean and lubricate
Fails to extract or eject	Fouled weapon	Clean and lubricate

SECTION IV. MACHINEGUNS

A. THE 7.62-MM M.A.G. 58 (BELGIUM) AND L7A1 (UK) MACHINEGUNS

194. General

a. The M.A.G. machinegun (fig 141) was developed in Belgium by the F.N. organization in 1958; M.A.G. stands for *Mitrailleuse a Gaz* or gas-operated machinegun. The M.A.G. is used not only by the Belgian Army, but also by British, Swedish, Israeli, and several other armies. The British guns (fig 142) are known as Machinegun 7.62-mm L7A1 (or L7A2) and are so marked on the left side of the receiver. The Swedish gun is the *Kulspruta 58*, and the other countries usually refer to these guns by the manufacturer's designation: M.A.G. 58.

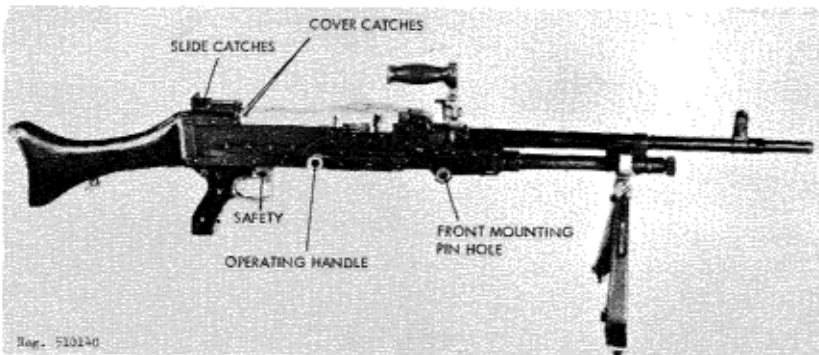

Figure 141. Belgium M.A.G. machinegun.

b. The M.A.G. is an air-cooled, gas-operated belt-fed general purpose machinegun. It is normally fired from its bipod, but it can also be mounted on and fired from a light tripod (figs 143 and 144). The barrel is of the quick change type. Special versions without butt stocks or bipods are available for use in armored vehicles. An accessory butt stock and bipod is carried in the vehicle for use when the gun must be dismounted for emergency ground use.

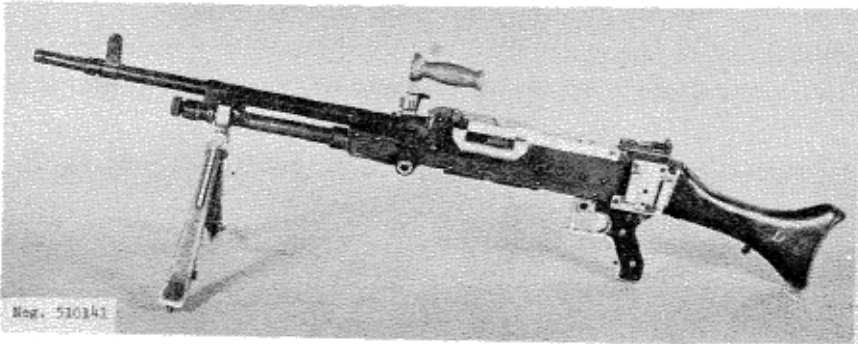

Figure 142. British L7A1 machinegun.

c. The British have several versions of their L7 series machinegun. These include the L8A1 (fig 145) and the L37A1 guns installed on armored vehicles. These guns, while basically L7 weapons, have special barrels and triggering mechanisms, and may have a gas extractor tube fitted under the barrel. These guns also may have butt stocks and bipods for emergency dismantled use.

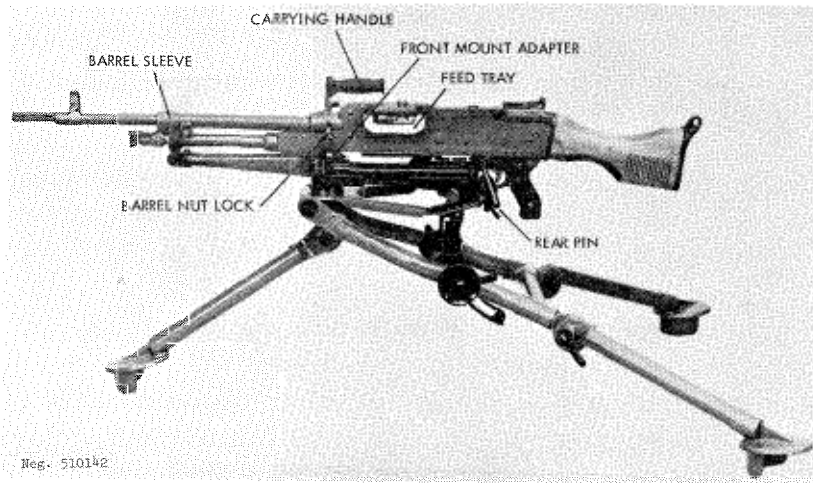

Figure 143. M.A.G. on tripod mount.

d. Most M.A.G.'s and the British L7A1 or A2 machineguns fire the 7.62x51-mm NATO cartridge (sec V). Early Swedish Kulsprutea 58's fire a Swedish 6.5-mm cartridge, but most of these now have been converted to 7.62-mm NATO.



Figure 144. L7A1 on tripod mount (w/o butt stock).

195. Technical Data

Technical data pertaining to the M.A.G. type machineguns will be found in table VII.

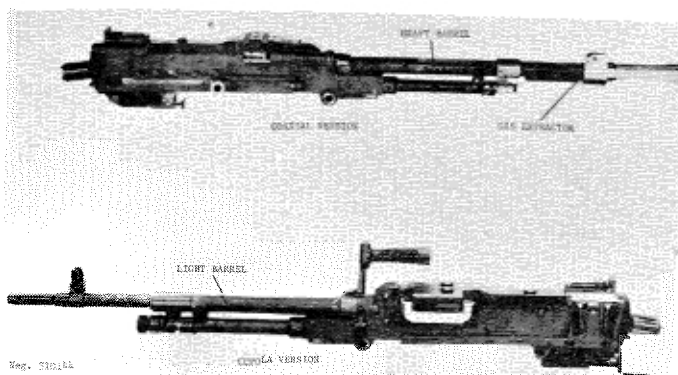

Figure 145. Tank versions of the M.A.G./L7A1.

196. Operation

a. M.A.G. machineguns use either a nondisintegrating metallic link belt or US M13 disintegrating links. The belts are not interchangeable, and as the guns are not marked to indicate which belt is to be used, this will have to be determined by testing before use. If the nondisintegrating belts are used, insert the cartridges into the link until the rib on the link extension snaps into the cartridge groove. Fifty-round belt sections can be joined by inserting the small link on the end of one belt into the slot of the large-end link of the other belt. Insure that the small projection on the small link is in the hole in the large link. Insert a cartridge to lock the links together. If M13 links are used, insert the single loop of one link between the double loops of another link. Insert a cartridge to join the links. Insure that the rib on the extension is engaged in the groove of the cartridge. If possible, put filled belts into the ammo containers.

b. Open the bipod by pressing in the bipod retainers (located on the receiver between the bipod feed), and at the same time, squeeze the bipod legs together to disengage them from the receiver. When the legs are free, swing them to open. To install the gun on a tripod mount, align the front mounting pin hole of the gun (fig 141) with the front adapter (fig 143) and install the front pin. Lower the receiver down onto the rear mount adapter and insert the rear pin. Refer to paragraph 199 for additional information on tripod mounts.

c. Pull the operating handle (fig 141) fully rearward and then thrust it fully forward. Press the safety (fig 141) to the right (to safe "S"). Press the cover catches (fig 141) and open the cover. Place a loaded ammunition belt on the feed tray, open side of the link down, and first cartridge resting against the cartridge stop (fig 141). Close the cover. CAUTION: The gun is now loaded and ready to fire.

d. Lift the rear slight leaf. Press the slide catches (fig 141) and move the slide along the leaf until the top of the slide aligns with the numeral that corresponds to the range in hundreds of meters. The battle sight, visible when the leaf is folded, is for ranges up to 200 meters.

e. To fire, press the safety to the left, aim (using a normal sight picture), and press the trigger. The gun will fire as long as the trigger is pressed and cartridges are in the belt. Short five-to-ten round bursts give best results. The bolt will remain open between bursts and close when the last round is fired.

f. When the barrel becomes hot from firing, it should be changed. Press the barrel nut lock (fig 143) and, while holding it in, rotate the carrying handle to its vertical position. (This action rotates the barrel nut and unlocks the barrel.) Pull the barrel forward, out of the gun. Place a cool barrel on the rest at the front of the gas tube (fig 146). Align the rear end of the barrel with its hole in the receiver and seat the barrel. Rotate the barrel handle down to the right until the barrel nut lock clicks into place.

g. The barrel handle is used both to carry the gun and to change the barrel. By pulling the handle out, away from the gun, the handle will disengage from the barrel nut and can be turned upward for carrying the gun. Prior to changing the barrel, turn the handle fully to the right to reengage it with the nut.

h. The gas regulator should be set so that the figure "1" is just visible under the left side of the sleeve around the barrel (fig 143). This gives a normal firing rate of approximately 650 rounds per minute. If a maximum rate of fire is desired, rotate the regulator until it is fully closed against its stop. Use settings "2" or "3" when the gun starts to malfunction due to fouling. Under very adverse conditions, close the regulator fully.

i. To clear or unload the gun, press the cover catch and open the cover. Lift the belt out of the feed way, inspect to insure that no cartridges are present, and close the cover. Pull the operating handle to the rear and, while holding it, press the trigger and ease the operating handle forward.

197. Disassembly and Assembly

a. Clear the gun (para 196i). Remove the barrel (para 196f). Press the cover catches (fig 141) and open the cover. Depress the butt catch (fig 146) and slide the butt upward until it is removed.

b. Press the end of the driving spring guide (fig 146) forward, then upward, and ease it to the rear. Remove the driving spring. Hold a hand behind the receiver rear opening and pull the operating handle (fig 141) sharply rearward. The bolt and operating slide will come out of the rear of the receiver and can be removed. Push out the link pin (fig 146) and separate the bolt from the slide.

c. To start reassembly, engage the slot in the front of the trigger group with the front edge of the slot in the receiver. Reinsert the trigger group pin.

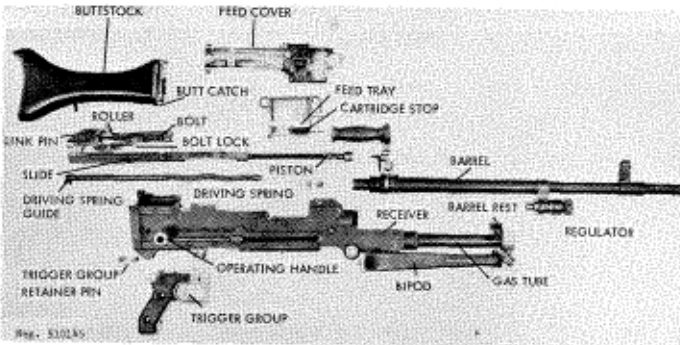

Figure 146. M.A.G. disassembled.

d. Align the holes in the link and slide and insert the link pin. Start the piston into the receiver. Press the bolt lock (fig 146) against the bolt and pull the bolt as far forward as possible from the slide. Align the bolt up with its guides and push the entire bolt and slide forward. Insert the driving spring into the slide, press the trigger, and use the spring to push the slide (and bolt) fully forward. Press the driving rod forward, against spring pressure, until it can be seated in the slot in the bottom of the receiver.

e. Start the butt in the vertical slot in the rear of the receiver and slide the butt down until it locks in place. Pull the operating handle to the rear. Close the cover, hold the handle, squeeze the trigger, and ease the handle forward.

198. Functioning

a. The M.A.G. is gas operated. (Refer to paragraph 128a.) The firing cycle commences when the slide and bolt are caught to the rear by the sear, cartridges are in the feed tray, and the trigger is pressed. Refer to figure 147 for diagrams of bolt functioning.

b. When the trigger is pressed, the sear releases the slide. The slide, under the force of the driving spring, starts forward; the bolt, attached to the slide, moves with it (fig 147). The feed rib drives the cartridge out of the feed tray and into the chamber.

c. The curved upper side of the lock contacts the cams on the bolt guide and starts to move down (fig 147). The bolt, continuing forward, chambers the round, and the extractor snaps into the cartridge case groove. As the bolt lock moves down, the link pin moves past the center line of the other two pins, and this causes the link to rotate down and seat the lock against the shoulder in the receiver (fig 147).

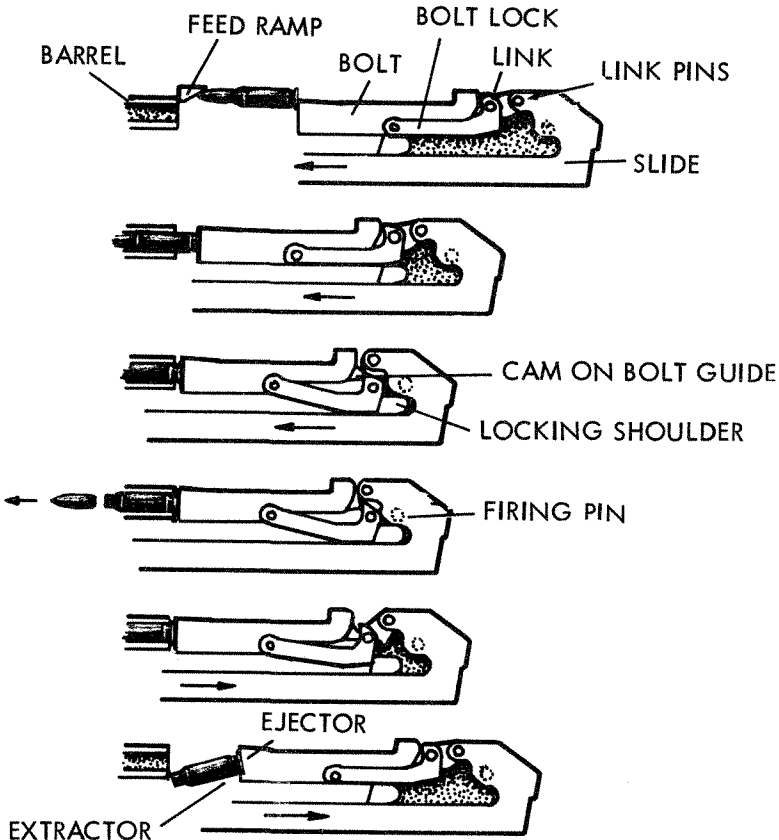

Neg. 510146

Figure 147. M.A.G. bolt functioning.

d. The slide continues forward, and the firing pin, mounted in the slide, finally strikes the primer and fires the cartridge. Forward motion ceases when the slide strikes the gas cylinder tube.

e. The propellant gases, vented into the gas cylinder after the bullet passes the gas port, drives the piston and slide rearward. This action compresses the driving spring and, upon first motion of the slide, retracts the firing pin into the bolt. The link rotates upward (fig 147) and pulls the lock out of engagement with the shoulder in the receiver. As the lock moves up, the curved surfaces bear against the bolt, which cracks the cartridge loose from the chamber. This slow initial extraction contributes greatly to the M.A.G.'s reliability.

f. As the slide continues rearward, the lock is completely withdrawn from the locking shoulder, and finally it (and the bolt) travel rearward with the slide. The extractor holds the cartridge case to the bolt face until the case clears the chamber. The ejector spring then expands, and the ejector expels the case from the bottom of the weapon (fig 147). Rearward motion ceases when the slide strikes the buffer.

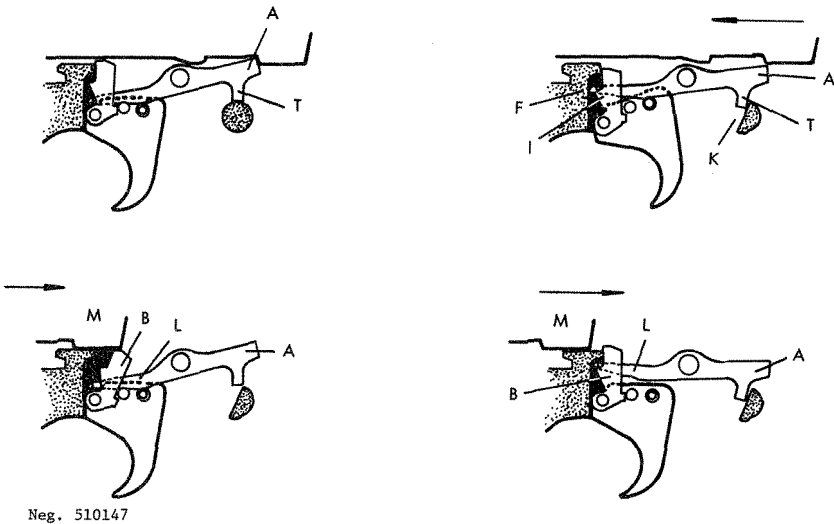
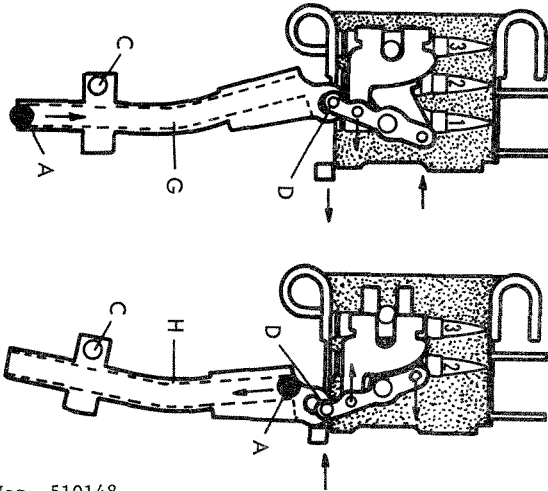

Figure 148. M.A.G. trigger functioning.

g. The trigger mechanism is very simple; refer to figure 148. When the trigger is pressed, it pivots on pin "c", and the roller "e" lifts the front of the sear. The sear "a" pivots on its pin and releases the slide. As the sear rises, the T-lug "f" is caught by the notch "g" of the sear catch "b". When the trigger is released, it rotates about its pin, and the sear catch moves upward. This action further elevates the front end of the sear. As the sear catch rises, it is hit by the recoiling bolt and rocked rearward, releasing the sear. The sear, under pressure of its spring, rises and catches the slide when it counterrecoils. This mechanism prevents slow rising of the sear, with resultant partial engagement of the sear and slide which causes battering and breakage.

h. The safety is a bar with a cutaway section. When the cutaway section is under the sear, the trigger, when pressed, causes the sear to depress and the cutaway provides room for the sear to move. When the safety is on Safe, the cutaway is moved to one side, and the solid portion of the safety moves under the sear to prevent it from depressing and releasing the slide (fig 147).



Neg. 510148

Figure 149. M.A.G. feed mechanism functioning.

i. The feed mechanism (fig 149) is actuated by the recoil and counterrecoil of the slide. A roller (A) on the slide rides in a channel in the belt feed lever (G). The lever is pivoted (C) and shaped so that the roller causes the front end of the lever to move from side to side. When the slide is released by the sear and starts forward, the roller moves in a straight section of the lever, and no sidewise motion occurs until the round in the feed tray is driven out of the link. At the time, the roller moves into the curved portion of the lever, and the front end (D) of the lever moves to the right. The lever causes the link to move the feed slide to the right. The pawls on the feed slide move the next cartridge inward, onto the slot on the feed tray. The cartridge guide snaps over the cartridge and holds it in the slot. When the slide is fully inward, a holding pawl snaps into place to prevent withdrawal of the round/belt. The round that had been rammed out of the feed tray fires, and the slide starts to recoil.

j. As the slide recoils, the roller moves the front end of the lever to the left; this causes the link to move the slide outward. The feed pawls override the cartridges held by the holding pawls and position themselves in preparation for feeding the next round.

199. Accessories

a. The most important of the accessories available for use with the M.A.G./L7A1 machineguns are the tripod mounts. There are two mounts: the M.A.G. tripod manufactured in Belgium and the L4A1 tripod used with the British L7A1 or A2.

b. Both tripods are set up by loosening the clamps on the legs and unfolding the legs, then tightening the clamps. Mount the gun according to the type of tripod as described in the following paragraphs.

c. For the M.A.G. tripod, remove the rear pin (fig 143) from its hole, then place the gun on the mount with the gun mount bosses engaged with the shoulders on the front of the front mount adaptor (fig 143). Align the rear pin holes in the receiver with the holes in the mount and insert the rear pin (fig 143). Reverse this procedure to remove the gun. To traverse the gun, loosen the traverse clamp. Tighten this clamp before firing. Fine traverse adjustments are made after tightening the traverse clamp by rotating the fine traverse knob. To elevate the gun, release the clamp on the elevating knob and rotate the knob to elevate or depress the gun. Relock the clamp before firing.

d. For the L4A1 tripod, pull out the mounting pin, place the gun on the cradle and slide the gun forward until it clicks into place. Reinsert the mounting pin. Reverse this procedure to remove the gun. To elevate or traverse the gun, loosen the socket clamp. This allows the gun and cradle to freely traverse and elevate on the ball and socket joint between the tripod and cradle. Tighten the socket clamp before firing. The right handwheel provides fine elevation adjustments, and the left handwheel, fine traverse adjustments.

e. Spare belts, belt boxes, spare barrels, and covers are usually provided for each gun. Simple combination tools to aid in disassembly are also used.

B. THE 7.62-MM AND .303 (7.7-MM) BREN LIGHT MACHINEGUNS (UK)

200. General

a. The Bren light machinegun is a British development based on the Czech ZB30 light machinegun. The basic Mark 1 Bren (fig 150) was adopted by the British Army in 1936. Although it was an expensive and difficult to produce weapon, it

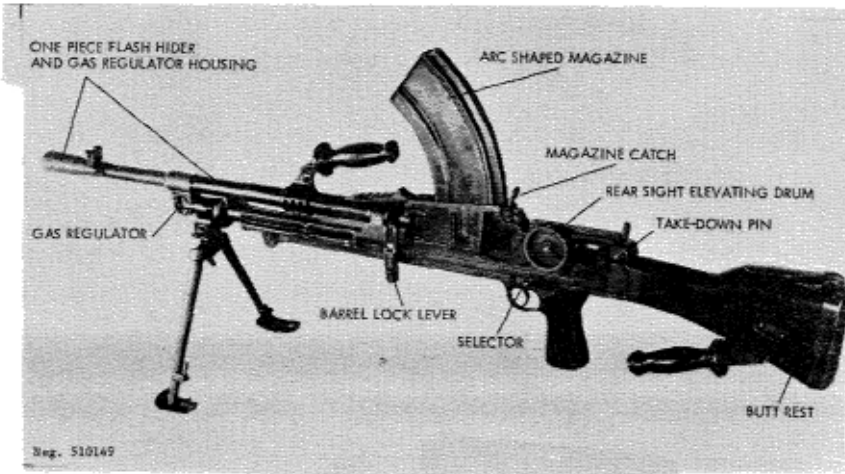

Figure 150. Mark 1 Bren.

rapidly replaced all other light machineguns in the British and Commonwealth armies. Two additional models were produced during World War II, a simplified Mark 2 (fig 151) and a lightweight Mark 3 model. In addition, a special model of the Mark 2 using the 7.92x57-mm cartridge was produced in Canada for the Nationalist Chinese (fig 152).

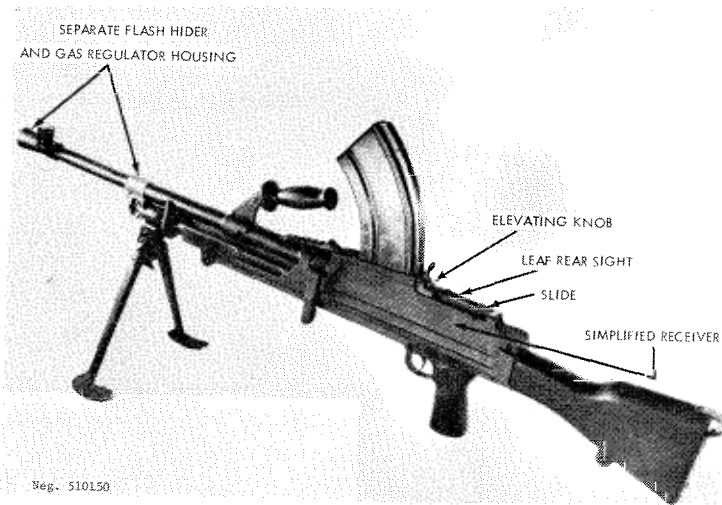

Figure 151. Mark 2 Bren.

b. The Mark 1 gun can be identified by its prominent rear sight elevating drum and one-piece stainless steel flash hider and gas regulator housing (fig 150). The other Brens have a leaf rear sight and a flash hider separate from the gas regulator housing

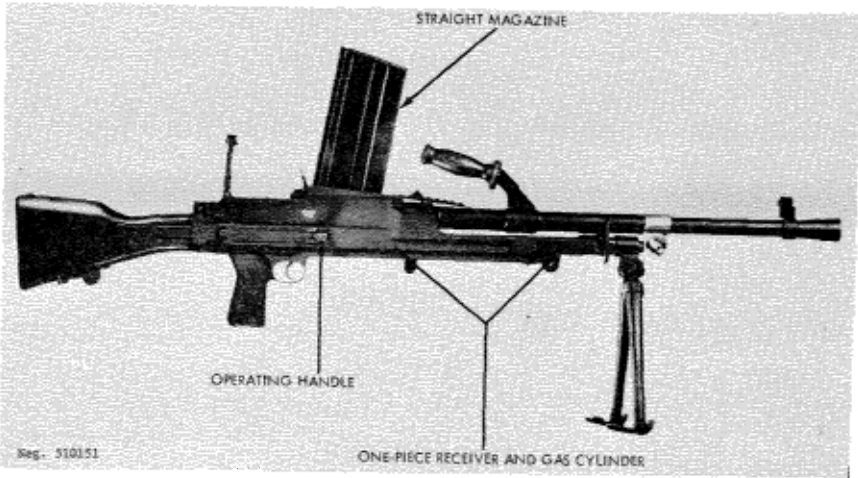

Figure 152. Mark 2M Bren.

(fig. 151). The Mark 2 and Mark 3 guns are similar; the Mark 3 gun however, has a shortened, smaller diameter, lightweight barrel. The 7.92-mm Mark 2M Bren can be identified by its straight magazine (fig 152) as opposed to the arc-shaped magazines used in the standard .303 Mark 1, 2, and 3 Brens.

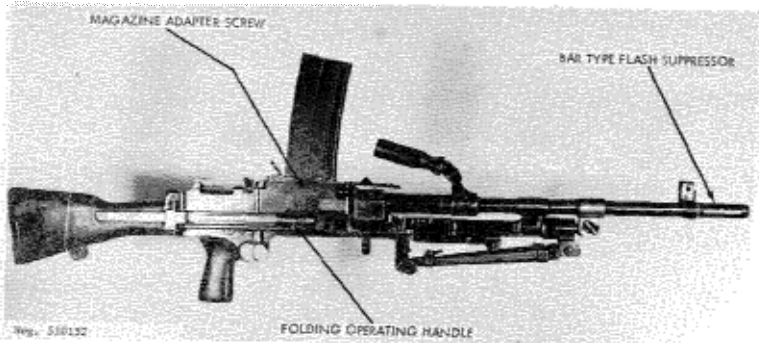

Figure 153. L4A1 Bren.

c. Many Brens now fire the 7.62-mm NATO cartridge. Some were converted from the earlier .303 models, and some are new production. These weapons, the L4 series (fig 153 and 154), can be identified by their bar-type flash suppressors and long, slightly curved magazine. The large head of the screws that hold the magazine adaptor in place is also a major recognition point.

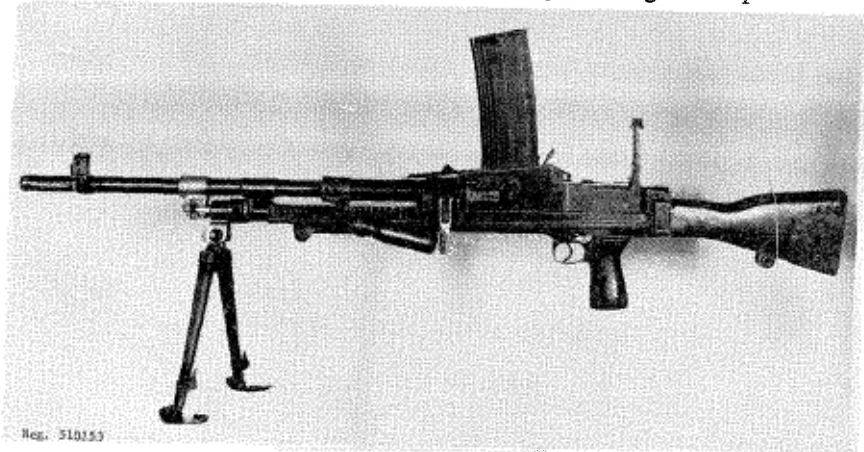

Figure 154. L4A1 Bren.

d. The Nationalist Chinese produced a version of the Mark 2 Bren. Their gun, the Type 41 light machinegun, fires the US .30-caliber M1906 cartridge (7.62x63-mm) and is easily distinguished from the other Brens by its receiver with the separate gas-cylinder tube (fig 155). The original pattern Mark 1



Figure 155. Nationalist Chinese Type 41 Bren.

Brens were also produced in Czechoslovakia after World War II. These guns can be identified by the Czechoslovak inscriptions on their receivers.

e. The British Brens, except for the L4 series, fire the .303 rimmed cartridge; the L4's fire the 7.62x51-mm NATO cartridge. The Canadian special Mark 2 fires the 7.92x57-mm cartridge, while the Chinese Type 41 fires the US .30-caliber M1906 cartridge. Information concerning ammunition will be found in section V.

201. Technical Data

Technical data concerning the Bren machineguns are given in table VII.

202. Operation

a. Load the magazines in the manner described in paragraph 128a. When loading rimmed .303 cartridges, insure that the rim of each cartridge, when loaded, is ahead of the rim of the preceding cartridge; otherwise, severe jams will occur.

b. The Bren bipod latches onto rails on the receiver when it is folded; a vigorous pull is necessary to disengage the bipod feet from the rails. Swing the bipod legs forward until they spring apart and lock into place. They can be folded by pressing the legs together and swinging them rearward until they can be engaged with the receiver. Some Brens have extendable bipod legs; extend these as necessary by pulling the lower leg out of the upper leg. Press the leg catch to release the lower leg and slide it back into the upper leg.

c. The leaf-sight-equipped Brens are adjusted for range by turning the knurled knob at the top of the leaf until the index mark on the slide (fig 151) is aligned with the number on the leaf that corresponds with the range in hundreds of yards (Mark 2-3) or meters (L4). For the early model Bren, turn the elevation drum (fig 150) until the desired range (in hundreds of meters) appears in the opening at the rear of the drum.

d. If necessary, slide forward the dust cover, over the magazine opening, tilt the magazine forward, and engage its front lug with the recess in the front of the magazine opening. Rock the magazine back until the magazine catch (fig 150) snaps into place.

e. Rotate the selector (fig 150) to its middle (safe) position. Grasp the operating handle (fig 152), pull it fully rearward, and then return it forward. (Some Brens have a folding operating handle; this must be unfolded prior to use.)

f. Rotate the selector (fig 150) forward for automatic fire or rearward for semiautomatic fire. CAUTION: The gun is now ready to fire. Using a normal sight picture, aim, and press the trigger to fire. The bolt will be caught to the rear when the magazine is empty.

g. Remove the magazine by pressing the magazine catch (fig 150) toward the magazine; at the same time press the magazine forward and rotate it out of the gun. Reload as described in paragraph c above. The gun does not have to be recocked after reloading.

h. The Bren machineguns have quick-change barrels. Remove the magazine; press the latch on the inside of the barrel lock lever (fig 150) into the lever to release the lever from the receiver. Rotate the lever up as far as possible, and by means of

the carrying handle, pull the barrel forward off the gun. Insert a replacement barrel, and insure that the gas cylinder enters the gas cylinder tube. Turn the barrel lock lever down until it locks in place; reload and resume fire. The barrel can be changed with the bolt rearward or forward.

i. The Bren guns have adjustable, rotary gas regulators (fig 150). The regulator can be set at four positions, each indicated by a different-sized dot drilled into the side of the regulator. The smallest gas port is used when the smallest dot is positioned between the barrel and the gas-cylinder tube. The regulator is changed to the next largest port whenever failure to eject occurs. To change regulator position, remove the barrel, and using a cartridge or combination tool, rotate the regulator 90°. Reinstall the barrel.

j. To clear the gun, set the selector to its middle (safe) position, remove the magazine, and then pull the operating handle rearward. Look through the magazine opening to insure that no cartridges are present. Move the selector from safe, grasp the operating handle, press the trigger, and ease the operating handle forward. Slide the magazine opening dust cover rearward; then slide the ejection cover rearward. Set the selector back to its middle (safe) position.

203. Disassembly and Assembly

a. To disassemble the weapon, clear the gun (para 202j), but do not close the dust covers or move the selector from its safe position. Remove the barrel (para 202h).

b. Press out the takedown pin (fig 150) from left to right and slide the butt and trigger mechanism rearward out of the receiver.

c. Hold a hand over the rear end of the receiver, and point the front end up. The slide and bolt will slide rearward; remove them. Pull the bolt rearward and up off the slide.

d. No further disassembly is necessary or desirable.

e. To reassemble the gun, place the bolt over the slide post and push the bolt forward on the slide so that the undercuts at the front of the bolt mate with their tracks on the slide. Insert the gas piston into the rear of the receiver, and when the piston is inserted far enough, align the ribs on the slide and receiver and push the slide into the receiver. Tilt the receiver down until the bolt and slide go forward.

f. Slide the butt and trigger mechanism into the receiver from the rear. Be sure that the driving-spring rod is seated into its recess in the end of the slide. When the butt and trigger mechanism are fully seated in the receiver, insert the takedown pin.

g. Replace the barrel and clear the gun.

204. Functioning

a. The Bren light machineguns are gas operated. When the weapon is fired, a portion of the propellant gases is diverted into a gas cylinder and drives the piston and attached parts rearward. The driving spring is compressed, and upon completion of the rearward movement, this spring drives the breech mechanism forward to reload and fire another cartridge.

b. The Bren machineguns commence their firing cycle with the slide and bolt held to the rear by the sear. The driving spring is compressed. When the trigger is pressed, the sear disengages from

the slide (fig 156), and the compressed driving spring forces the slide and bolt forward. The feed ribs on the top of the bolt force a cartridge from the magazine and drive it into the chamber. The front of the bolt strikes the end of the barrel, the extractor snaps into the groove of the cartridge case, and the bolt stops. The slide continues forward, and a cam on its top side forces the sear end of the bolt upward into its seat in the receiver. The slide then continues forward a short distance, and its hammer (fig 156) strikes the firing pin to ignite the cartridge.

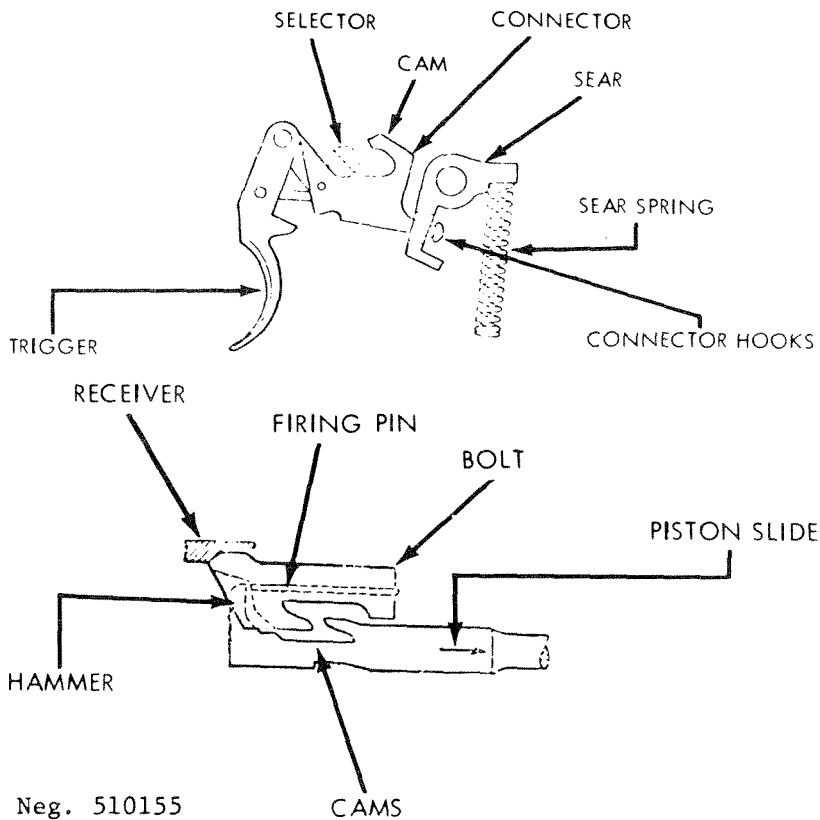

Figure 156. Bren bolt and trigger mechanism functioning.

c. The propellant gases from the cartridge drive the bullet through the barrel. Just before the bullet reaches the muzzle, some of the gases are diverted through the gas port and into the gas cylinder. The gases then drive the piston rearward. As the piston and slide move rearward, the driving spring is compressed.

d. As the slide moves, the cams on the slide (fig 156) contact the bolt and pull it down from its locked position; when unlocked, the bolt and slide travel rearward as a unit. The extractor pulls the fired cartridge case from the chamber and holds the case to the bolt until the ejector strikes the case. The case then pivots on the extractor and is expelled through the ejection port in the bottom of the gun. The slide finally strikes the buffer and stops. The driving spring then drives the slide forward, and another cycle commences.

e. The Bren trigger mechanism can be set for either semi- or full-automatic fire by rotating the selector (fig 156). When the selector is rotated forward to the full automatic setting, a solid section on its shaft depresses the connector, which fits through a hole in the lower arm of the sear. As the trigger is pressed, the connector moves forward; the lower hook (fig 156) engages the sear and causes it to rotate about the pin. The sear nose releases the slide and, the firing cycle commences and continues until the trigger is released and the sear spring forces the sear up to intercept the slide.

f. When the selector is rotated rearward to the semiautomatic setting, the connector rises to its highest position; as the trigger is pressed, the upper hook of the connector rises to its highest position. As the slide drives forward, it hits the cam (fig 156) on the connector and forces the connector down. The hook releases the sear that, because of its spring, snaps up and catches the slide when it recoils. Thus only one shot is fired; the

trigger must be released to allow the connector to move rearward and its hook to reengage the sear so that a second shot can be fired.

g. When the selector is rotated to its middle or safe position, the hooks are positioned centrally in the hole in the sear (fig 156). Thus, when the trigger is pressed, the connector hooks do not activate the sear to release the slide.

h. The magazine platform has a rear-edge lug that can drop in front of the bolt when the last round has been fed. When the bolt recoils after firing the last round, the lug stops the bolt; this, in turn, stops the slide slightly to the rear of the place where it normally would be engaged by the sear. As the empty magazine is removed, the bolt and slide move slightly forward onto the sear, and after a loaded magazine is inserted, the gun is again ready to be fired.

205. Accessories

A wide assortment of accessories are available for the Bren. The following are usually found with these weapons: spare barrel; extra magazines with a metal magazine box or web or leather magazine carrier; a sling; and a tool roll or box with cleaning rod, combination tool, spare parts (firing pins, extractors, ejectors, springs, etc.), and a gun cover.

C. THE 7.5-MM AA-52 MACHINEGUN (FRANCE)

206. General

a. The AA-52 machinegun (fig 157 and 158) is the standard general-purpose machinegun of the French Army. The gun can be readily fitted with one of two different weight barrels, fired from a bipod (fig 157) or a light tripod (fig 159), and fired

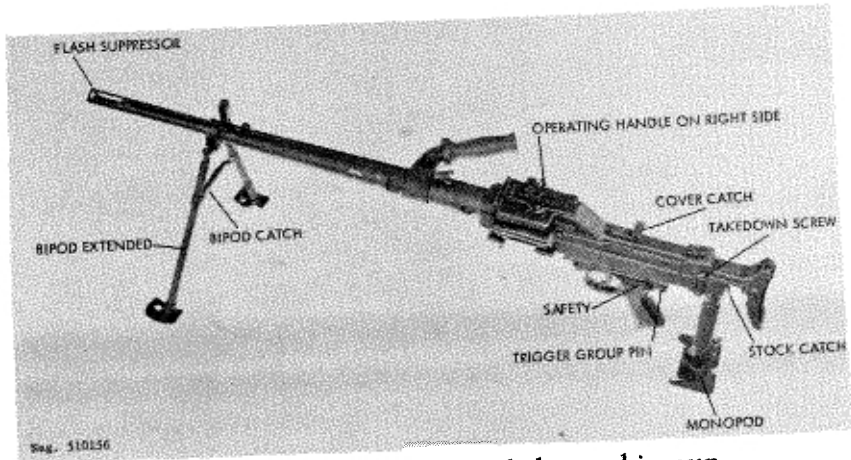

Figure 157. French AA-52 light machinegun.

with the sliding stock folded or extended. A heavy-barrel model without stock or sights is also available for use in coaxial mounting of armored vehicles (fig 160).

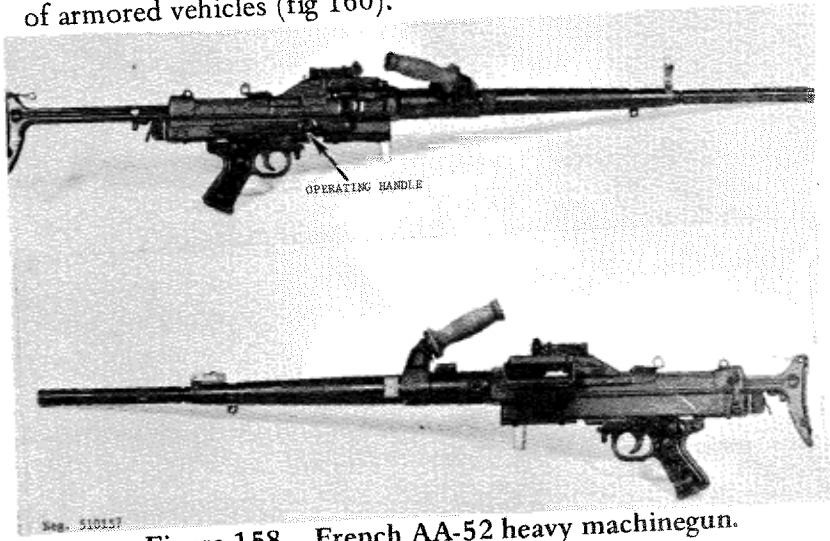

Figure 158. French AA-52 heavy machinegun.

b. The AA-52 or its export model AAT-52 (Armes Automatic, Transformable) (convertible machinegun) is a delayed-blowback operated, fully automatic, metallic link-belt fed weapon equipped with a quick-change barrel. The delayed-blowback operation requires a fluted chamber that leaves characteristic lines on the fired cartridge case.

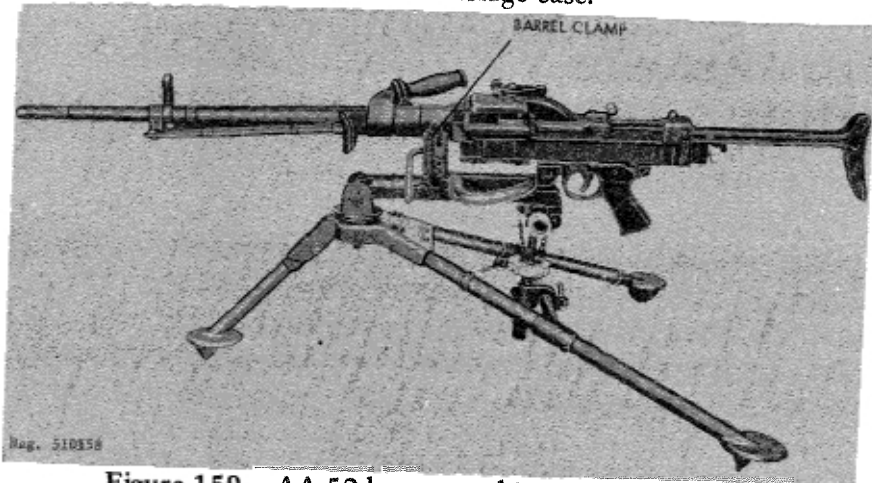

Figure 159. AA-52 heavy machinegun on tripod.

c. The French Army and some of the former French colonies use this chamber for 7.5x54-mm cartridges. This version is officially known as the AA-52. By changing barrels, 7.62x51-mm NATO cartridges can be used; this version (AAT-52) is offered for commercial sale and is often found as a tank version (fig 160) in armored vehicles sold by France.

d. Additional information on ammunition used can be found in section V.

207. Technical Data

Technical data pertaining to the AAT-52 machinegun will be found in table VII.

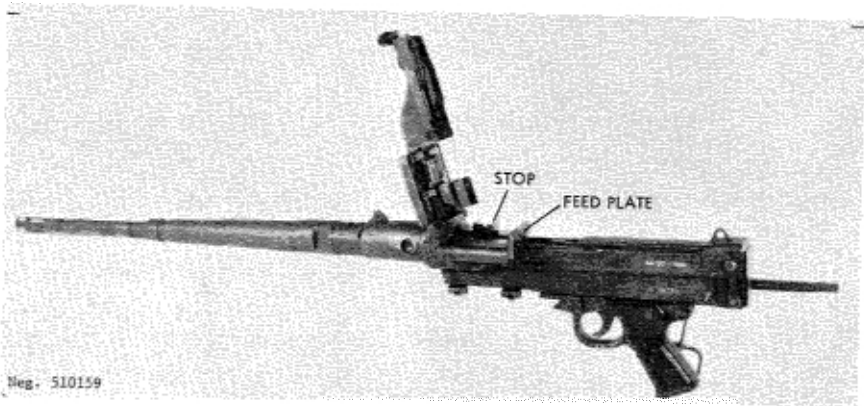

Figure 160. AAT-52 tank machinegun.

208. Operation

a. Ammunition for the AAT-52 normally will come in belts. However, if empty belts and loose cartridges are to be used, insert a cartridge into each link insuring that the tab on the link snaps into the cartridge groove. Be sure to use the right ammunition: 7.62-mm cartridges cannot be used in 7.5-mm guns and vice versa; 7.62-mm barrels are stamped on top "M52-300-7.62". Only feed belts designed for this gun can be used.

b. If the weapon is bipod equipped, unsnap the catch (fig 157) and swing the bipod down. When it is at a right angle to the barrel, spread the bipod legs. If the gun is to be used on a tripod, mate the front recess of the trigger guard with the mount adaptor, then close the barrel clamp (fig 159) and tighten. Press the catch (fig 157) and extend the stock if desired.

c. Pull the operating handle (fig 158) fully rearward, then thrust it fully forward. Press the safety (fig 157) to the left (safe). Press the cover catch (fig 157) forward and open the cover.

d. Place a loaded belt, open side of the links down, across the feed plate (fig 160). The first cartridge must rest against the stop (fig 160) and the belt must be located between the stop and the rear of the feed plate. Close the cover. CAUTION: The gun is loaded and ready to fire.

e. Erect the front sight, then press in the catch on the rear sight and move the slide along the bar until the correct range, in hundreds of meters, is aligned with the slide. Press the safety to the right. Aim, using a normal sight picture, and press the trigger. The AAT-52 will fire as long as the trigger is pressed and cartridges are in the feed belt. The bolt will remain open between shots and close on an empty chamber when the last round in the belt is fired. Short, three-to-five-shot bursts, with re-aiming between bursts, give best results.

f. To unload or clear the gun, pull the operating handle fully rearward, then thrust it fully forward and press the safety to the left. Press forward the cover catch and open the feed cover. Lift the belt off the feed tray. Inspect to insure that no cartridges are present in feed, receiver, or barrel, then close the feed cover. Push the safety to the right, draw the operating handle to the rear (while holding it), squeeze the trigger, then ease the operating handle forward.

g. To change barrels, pull the operating handle fully rearward and push the safety to the left. Press down on the barrel lock (fig 161) (on some guns, pull back on barrel lock) and, using the carrying handle, rotate the barrel to the right until it stops, then pull it forward out of the receiver. Insert the fresh barrel fully into the receiver, then rotate it to the left until it locks into place.

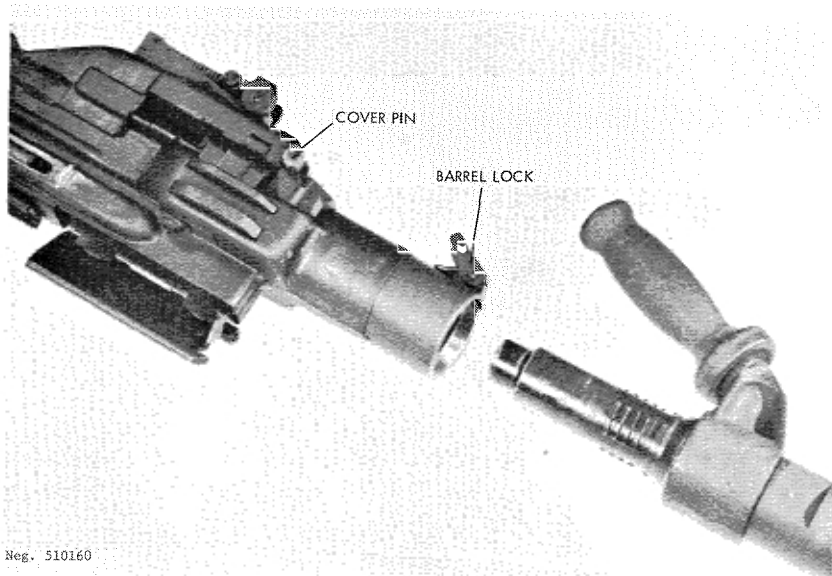

Figure 161. AA-52 barrel change.

209. Disassembly and Assembly

- a. Clear the gun (para 208f). Press the cover catch (fig 157) forward and open the feed cover.
- b. Unscrew the takedown screw (fig 157) at the left rear of the receiver and remove it. **CAUTION:** Press down on top of the butt while removing the takedown pin. Ease the butt stock upward and remove it. Pull out the driving spring and guide.
- c. Slide the bolt rearward until it can be removed (Note: The bolt head may separate from the bolt during removal; if so, just pull the bolt head out of the receiver). Pull the firing pin out of the bolt head or bolt body as required after separating the bolt head and bolt body (fig 162).
- d. Remove the trigger group pin (fig 157) after depressing its lock, and pull the trigger group out of the receiver.

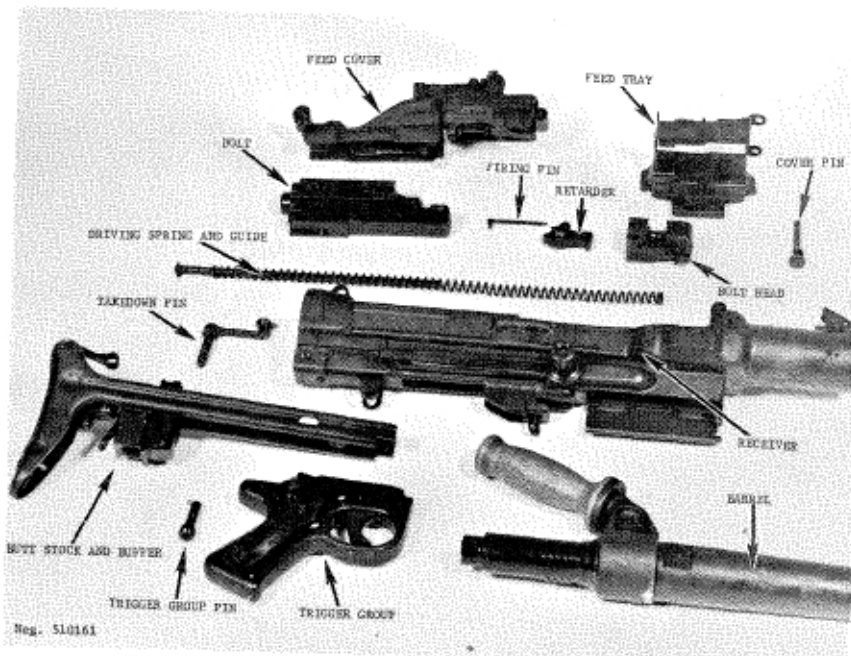

Figure 162. AA-52 disassembled.

e. Lift the feed tray (fig 162) up against the open feed cover and pull out the pin (fig 162) by its knurled head. Remove the feed cover and feed tray. No further disassembly is necessary or desirable.

f. Assemble the feed tray and feed cover to the receiver and insert the cover pin as far as possible. Fully open the cover and feed tray and seat the pin.

g. Insert the trigger group into the bottom rear slot of the receiver. After mating the slot in the front of the trigger group with the receiver, slide the trigger group forward until the trigger group pin can be inserted.

h. Insert the firing pin into the bolt head, but leave about 1-1/2 inches protruding. Place the bolt head onto the bolt body so

that the tang of the firing pin enters the hole in the bolt body. Seat the bolt head against the bolt body. It may be necessary to push in the rear of the retarder prior to sealing the bolt head.

i. Start the bolt head into the receiver and press the retarder forward and inward until the bolt enters the receiver. Press the trigger and move the bolt fully forward. Insert the driving spring, free end first, into the bolt body.

j. Seat the driving spring into the recess in the back plate, then mate the lip on the top of the back plate with its recess in the inner top of the receiver. Press down on the top of the butt stock to seat the back plate and insert the takedown screw. Tighten the takedown screw. Pull the operating handle rearward, close the cover, hold the handle, press the trigger, and ease the handle forward.

210. Functioning

a. The AAT-52 functions on the principle of delayed blowback. As soon as the cartridge fires, gas pressure generated drives the bolt rearward; however, a mechanical retarder prevents all but a minimum of bolt head movement until the gas pressure has greatly subsided. Because the cartridge case does move, albeit a very small distance, under high gas pressure, the AAT-52 chamber has lengthwise flutes cut into it. These flutes allow gas to leak back and "float" the front of the case on a film of gas. Because of this, the case does not adhere to the chamber and case ruptures are prevented.

b. When the AAT-52 is cocked and a loaded belt is in the feed tray, pressure on the trigger releases the bolt which, under the force of the driving spring, starts forward. At this time, the retarder is flush with the right side of the bolt head. The retarder

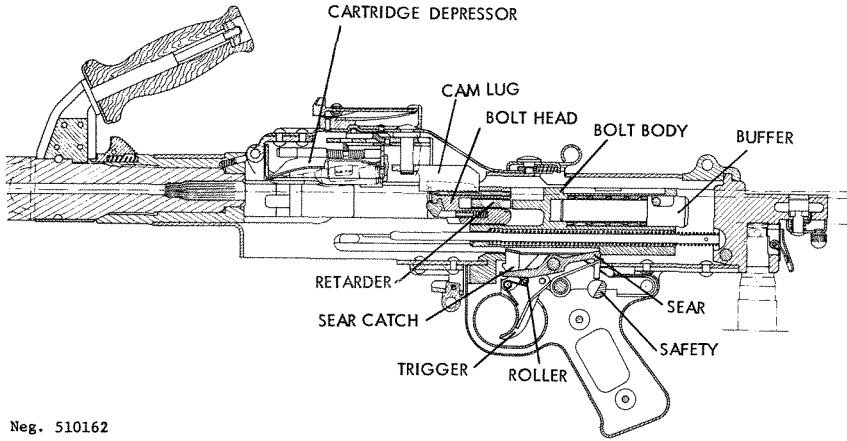

Neg. 510162

Figure 163. AA-52 section.

also holds the bolt head away from the bolt body. The feed rib on the bolt head drives the cartridge out of the feed tray and into the barrel. The extractor snaps into the cartridge case groove, and the bolt head strikes the end of the barrel and stops. At this time, the retarder aligns with a recess in the receiver and, as the bolt body continues forward, a cam forces the retarder to rotate outward. The firing pin, connected to the bolt body, also continues forward and fully fires the cartridge. Forward motion ceases when the bolt strikes the bolt head.

c. Upon firing, the gas pressure generated immediately thrusts the bolt head rearward. The retarder lever is outward, being against the rear wall of its recess (fig 164) and, as the bolt head moves the retarder is forced to swing inward. The inner arm of the retarder presses against the bolt body and, before the retarder can rotate, it must force the bolt body rearward away from the bolt head (fig 164). This action causes a 3:1 mechanical disadvantage against the bolt head while accelerating the rearward motion of the bolt body. The mechanical disadvantage, in essence,

keeps the bolt head locked until gas pressure has subsided to a safe degree. The inertia imparted by the retarder to the bolt body is sufficient to move the entire bolt rearward and compress the driving spring.

d. The extractor holds the fired cartridge against the bolt face until the twin fixed ejectors on the bottom rear of the feed tray strike the cartridge and expel it out the bottom of the gun. Rearward movement ceases when the buffer (fig 162) in the rear of the bolt strikes the backplate. If the trigger is still depressed, another firing cycle starts.

e. The shuttle-type feed mechanism, quite simple in function, is actuated by the recoil and counterrecoil of the bolt. A cam lug on (fig 164) the pivoted belt feed lever projects into a recess (fig 164) in the top of the bolt. As the bolt drives forward and pushes the round out of the feed tray, a cam surface at the rear left of the bolt recess contacts the cam lug on the belt feed lever; this moves the front end of the lever (and the attached belt feed slide) outward. The spring-loaded pawls of the feed slide override and then snap over the next cartridge to be fired. Upon firing and resultant bolt recoil, the angular right side of the bolt recess actuates the belt feed lever inward. The feed pawls thus move the next round into position over the slot in the feed tray. The spring-loaded cartridge depressor (fig 164) holds the cartridge solidly in the slot and the fixed belt holding pawls in the cover prevent the belt from moving out of the gun during feed.

f. The trigger mechanism (fig 163) is also simple. When the trigger is pressed, a roller contacts the sear and lifts its front end. The rear end of the sear depresses and releases the bolt. As the trigger is pressed, the sear catch, attached to the front of the trigger, moves down and, as the front of the sear rises, the sear snaps forward over the "T" lugs at the front of the sear. When the

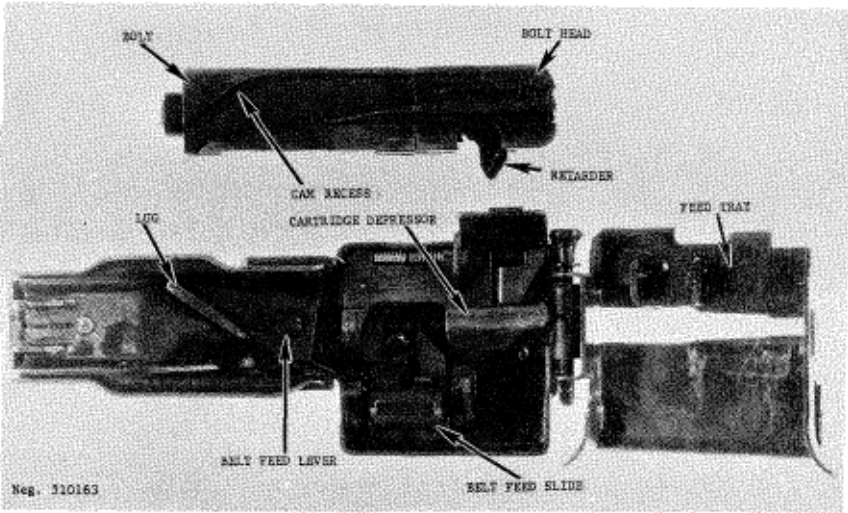

Figure 164. AA-52 bolt and feed cover.

trigger is released, the sear catch moves upward and, because it now holds the sear "T" lug, the sear pivots further about its pin, further depressing the sear nose. The sear catch finally rises far enough so that the recoiling bolt rocks it rearward to release the sear. The sear snaps upward and, when the bolt counterrecoils, the sear engages the sear notch and holds the bolt cocked. This use of a sear catch prevents slow rising of the sear with resultant partial engagements and chipping or breakage of the sear and bolt.

g. The safety, when applied, puts a solid bar under the sear, preventing the sear from being depressed. When the safety is moved to the fire position, a cutaway section moves under the sear. The sear can then be depressed to release the bolt.

211. Accessories

a. The usual accessories for machineguns are available for the AAT-52. These include:

- belts.
- (1) Extra 50-round nondisintegrating metallic feed belts.
 - (2) Belt boxes.
 - (3) A 50-round bandoleer, which can be attached to the feed tray.
 - (4) Cleaning rods and cleaning equipment.
 - (5) Spare firing pins, extra springs, and the like.

b. The AAT-52 can be mounted on the French M52 tripod or, with a suitable adapter, on the US M2/M122 tripod mounts.

D. THE 7.5-MM MODEL 24/29 LIGHT MACHINEGUN (FRANCE)

212. General

The 7.5-mm Model 24/29 (fig 165) was a standard pre-World War II French Army weapon that was put back into production after the war. It is an excellent weapon of simple design and unsurpassed ease of maintenance. Although the French refer to this weapon as an automatic rifle, it is a light machinegun by contemporary standards. The Model 24/29 is sometimes referred to as the Chatellerault machinegun. Its double triggers, large wood forearm, and multiperforated conical flash hider are prime recognition features. There is a large vertical hole in the forearm; this is to adapt the gun to an antiaircraft or vehicular post mount. Although obsolescent in the French Army, the Model 24/29 is still in widespread use in many former French possessions. The Model 24/29 fires the 7.5x54-mm cartridge (sec V).

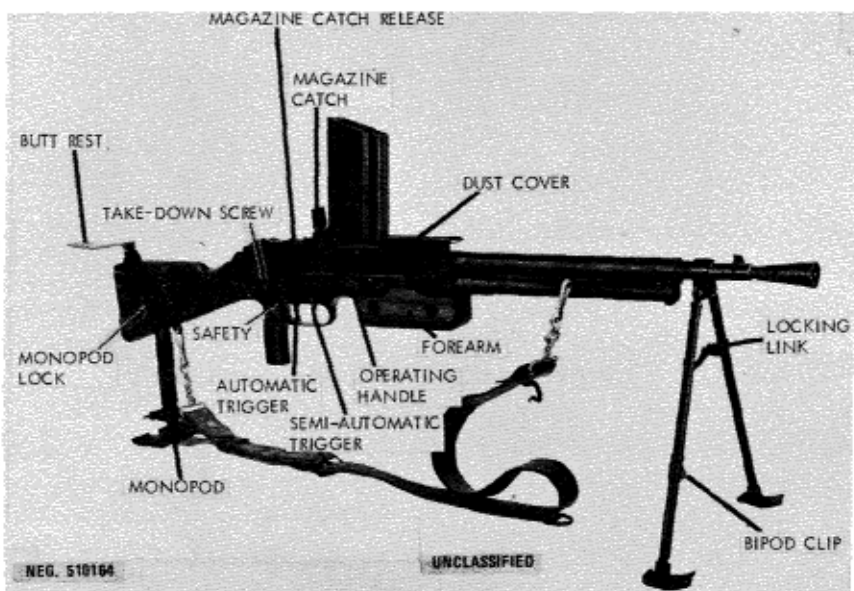

Figure 165. French Model 24/29 light machinegun.

213. Technical Data

Technical data concerning the Model 24/29 light machinegun are given in table V.

214. Operation

- a. Load the magazine as described in paragraph 128a.
- b. Unhook the clip that holds the bipod legs together, then swing the legs forward and down. Spread the legs until they are locked open by the locking link between the legs.

c. Open the dust cover by turning the dust cover lock (fig 166) upward, then pull the magazine catch release (fig 165) rearward; this will allow the magazine catch to spring up into position. Fold the dust cover forward over the barrel. If necessary, the rear sight aperture can be swung to the left for use. Set the sight to the desired range by depressing the locks and moving the slide along the ramp until the top of the slide is aligned with the figure that corresponds to the range in hundreds of meters. Unfold the butt rest if desired.

d. Hold the magazine, tilted forward, and mate the lug (fig 166) on its front side with the recess in the magazine well. Rotate the magazine rearward until the magazine catch snaps into place. Pull the operating handle fully rearward; then push it forward. CAUTION: The gun is now ready to fire. If desired, render the gun safe by moving the safety (fig 165) downward.

e. To fire, push the safety upward; using a normal sight picture, aim and press one of the triggers. Pressing the front trigger will fire one shot; the trigger must then be released and repressed to fire another shot. Pressing the rear trigger will cause the gun to fire until the magazine is empty or the trigger is released.

f. When the last cartridge in the magazine is fired, the bolt will remain open. Press the magazine catch (fig 165) toward the magazine and, at the same time, tip the magazine forward out of the gun.

g. To clear the M24/29, rotate the safety downward, remove the magazine (para f above), and pull the bolt fully rearward. Inspect to insure that no cartridges are present. Press the safety upward, hold back on the operating handle, press one of the triggers, and ease the operating mechanism forward. Swing the dust cover (fig 165) to the rear over the magazine opening; then

swing the ejection port cover down. Lock it in place by turning the lock lever down. Reset safety to safe and press the magazine catch back until it locks.

h. Fold the bipod by pressing the center of the locking link upward; then fold the legs together. Swing them backward and secure them with the bipod clip (fig 165). The bipod can be stowed under or alongside the barrel.

215. Disassembly and Assembly

a. Clear the gun (para 214g), but do not close the dust cover; leave the safety upward in the fire position.

b. Unscrew the takedown screw (fig 165) until it can be pulled out of its hole. Tilt the butt up and off the receiver. The trigger group will swing down.

c. Press the front end of the trigger group into the receiver; then remove the trigger group. The ejector is housed in a dovetail in the left wall of the receiver; pull the ejector rearward and out of the gun.

d. The driving spring can now be pulled rearward and removed from the slide (fig 166).

e. Pull the operating handle rearward. This will move the bolt and slide to the rear where they can be grasped and pulled out of the receiver. Turn the tube lock (fig 166) to the vertical position and swing the rear end of the gas cylinder tube to the right; after it disengages from the receiver, it can be removed.

f. The bolt link pin can be pulled out and the bolt can be separated from the slide.

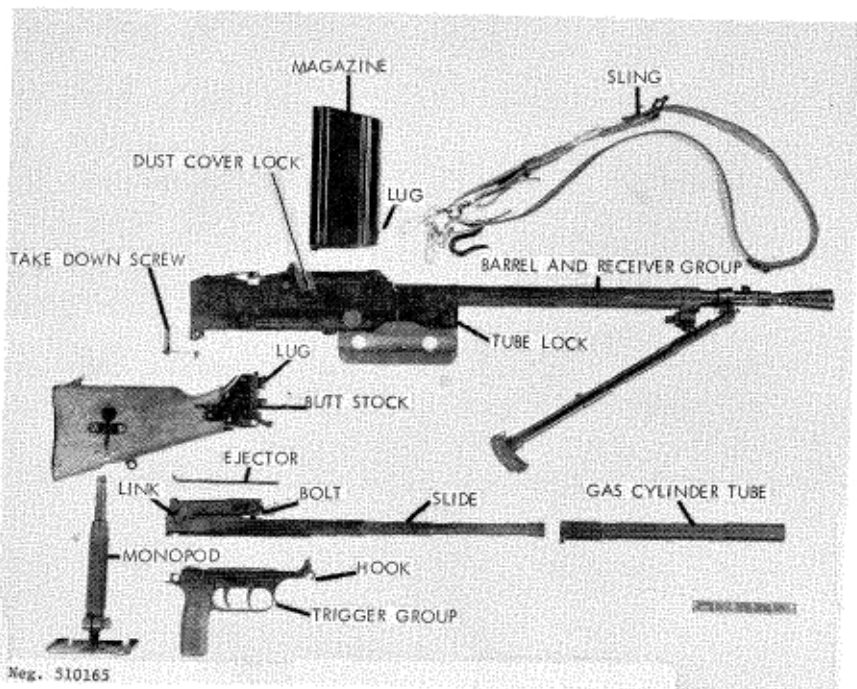

Figure 166. M24/29 disassembled.

g. Although further disassembly is neither necessary nor desirable, the barrel can be removed. Turn the barrel lock at the left front end of the receiver to the "O" marking. Place a wrench on the flats on each side of the rear end of the barrel and unscrew it. The barrel has right hand threads. The barrel is replaced by screwing it into the receiver until it seats and the lines on the barrel and receiver are aligned. Turn the barrel lock back to its lock position.

h. Place the bolt onto the slide, position the link (fig 166), and replace the link pin.

i. Mate the gas cylinder tube with the gas cylinder and slide the rear end of the tube to the left and into place in the receiver.

j. Push the bolt as far forward as possible on the slide; then insert the bolt and slide into the receiver, insuring that the piston enters the gas cylinder tube. Tip the muzzle down so that the bolt and slide will go fully forward. Replace the ejector (fig 166) into its recess.

k. Insert the driving spring and guide into the slide, guide to the rear. Mate the hook (fig 166) on the trigger group with its cross pin in the receiver; then swing the trigger group up into place.

l. Hold the stock at an upward angle to the receiver and fit its lug (fig 166) into its recess in the inner top of the receiver. Hold the trigger group up in place and swing the stock down until it seats against the receiver. Insert the takedown screw, from the right, and screw it fully home. Close the dust covers, fold the aperture to the right, and press the magazine catch down until it is locked in place.

216. Functioning

a. The M24/29 light machinegun is gas operated and commences its firing cycle with the slide and bolt held to the rear by the sear. When either trigger is pressed, the sear disengages from the slide, and the compressed driving spring forces the slide and bolt forward.

b. The feed ribs on the top of the bolt force a cartridge from the magazine and drive it into the chamber. The extractor snaps into the groove of the cartridge case, and when the front of the bolt strikes the end of the barrel, the bolt stops its forward movement. The slide continues forward and the links (fig 167) pivot about the pin to force the rear end of the bolt up into its seat in front of the locking shoulder. The slide continues forward

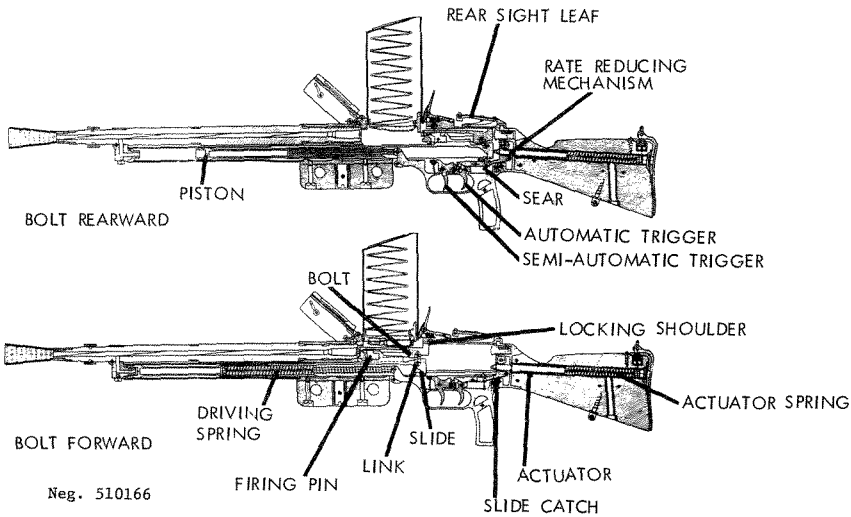

Figure 167. M24/29 section.

until the firing pin (fig 167) mounted on the slide strikes the primer and fires the cartridge.

c. The propellant gases drive the bullet down the barrel and, after the bullet passes the gas port, some of the gases are diverted into the recessed head of the piston (fig 167). These gases drive the piston and slide to the rear, compressing the driving spring and retracting the firing pin. After a short free travel, the link pin on the bolt and the links rotate and pull the bolt down out of engagement with the locking shoulder. The extractor withdraws the fired cartridge case from the chamber and holds it against the bolt until the end of the ejector strikes the case and expels it from the gun.

d. The bolt and slide continue to the rear until the slide hits the actuator (driving it to the rear against its spring) and buffer. The driving spring then drives the bolt and slide forward to commence another firing cycle.

e. The trigger mechanism consists of a conventional sear and two triggers, one for automatic and one for semiautomatic fire. If the weapon is cocked, i.e., the slide is held to the rear by the sear (fig 168); pressure on the rear or automatic trigger (fig 168) will lift the front end of the sear and cause it to disengage from and release the slide and thus commence the firing cycle. The sear rises and catches the slide to the rear, thus stopping the firing cycle, only when the trigger is released.

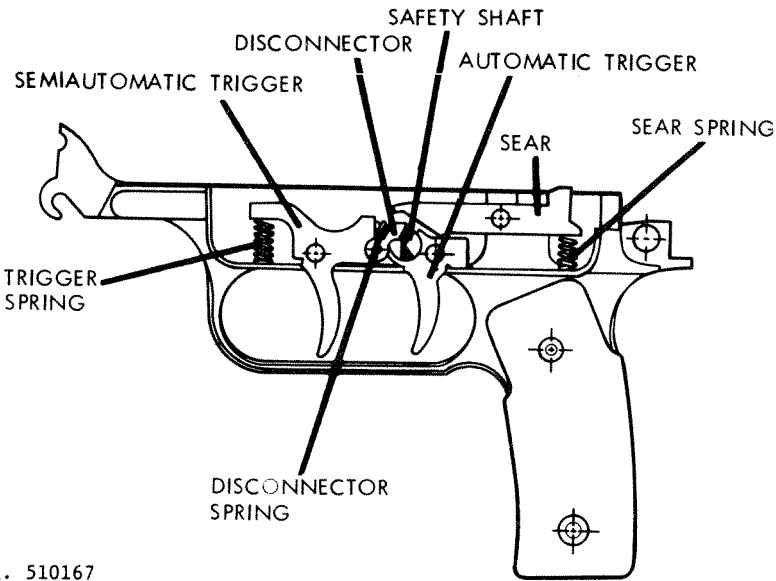

Neg. 510167

Figure 168. M24/29 trigger mechanism.

f. When the front or semiautomatic trigger (fig 168) is pressed, the disconnecter lifts the front end of the sear, causing the sear to release the slide. As the trigger moves, the disconnecter, because it moves in a circular path (on the end of the trigger), travels forward until it moves out from under the sear. The sear spring snaps the sear upward to intercept the slide. To fire a second shot, the trigger must be released so that the trigger

spring can force the trigger forward and lower the disconnecter. The disconnecter pivots toward the trigger as it passes the front of the sear, and as soon as the disconnecter is under the sear, the disconnecter spring forces the disconnecter rearward under the sear. Pressure on the trigger will now cause the triggering action to be repeated and another shot to be fired.

g. When the safety is rotated downward to the safe position, the safety shaft (fig 168) rotates so that its lower end blocks the semiautomatic trigger and its upper end blocks the automatic trigger. Because neither trigger can be pressed, the arm cannot be fired.

h. The butt of the M24/29 light machinegun has a simple rate reducing mechanism. When the slide recoils, it drives the actuator (fig 167) to the rear against its spring. At the same time the slide catch engages the slide and holds it to the rear until the actuator is driven forward. When the heavy actuator reaches the end of its return stroke, it depresses the slide catch to release the slide. The time lag caused by the movement of the actuator results in a reduced cyclic rate of fire.

217. Accessories

Several accessories are available for the M24/29 light machinegun. Opening a sliding plate in the butt plate reveals a spare ejector and takedown screw housed in recesses in the butt stock. A leather sling is used to carry the M24/29 and, when available, a simple monopod can be inserted into a socket in the bottom of the butt stock. The monopod, in conjunction with the bipod, forms a tripod mount for better stability during long-range firing. The monopod is removed by pressing the key-shaped latch on the right side of the butt stock and pulling the monopod out of its socket. Spare magazines, magazine carriers and a spare barrel are normally carried with each M24/29.

5 September 1980

E. THE 5.56-MM OR 7.62-MM HECKLER AND KOCH HK 13,
HK 21, AND HK 21A1 MACHINEGUNS (WEST GERMANY)

218. General

a. The 5.56-mm HK 13, HK 21, and HK 21A1 machineguns are based on the design of the G3 rifle (para 144). The three guns are similiar, but the HK 13 (fig 169) is fed only by box magazines, the HK 21 (fig 170) is fed by belt, or with an adapter, by box magazines, and the HK 21A1 (fig 170.1) is an improved, lightened HK 21. The guns, as covered here, are 5.56-mm; however, they are also available in 7.62-mm, and in the case of the HK 21 may be converted from one caliber to the other.

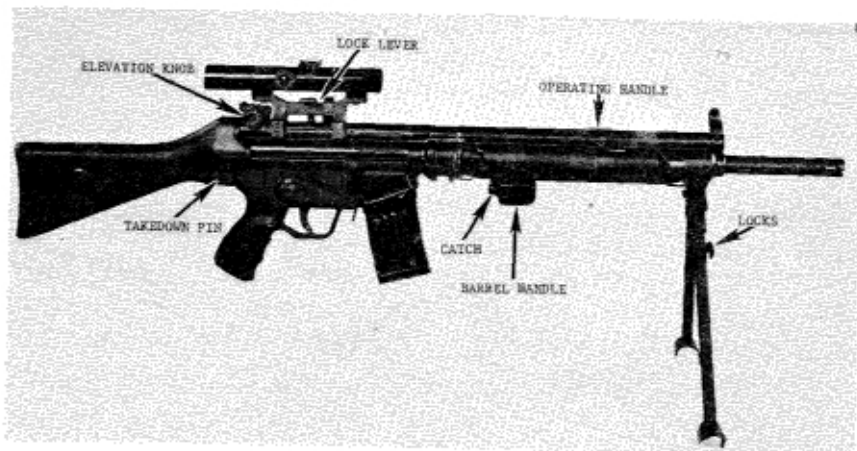

Neg. 510168

Figure 169. West German HK 13 light machinegun.

b. The HK 21 is used by Portugal and Sweden (in 7.62-mm), and all guns are offered for sale commercially. The Heckler and Koch machineguns can be identified by their short, compact appearances, operating handle at the front of the receiver (fig 170), and prominent barrel change handle (fig 170).



Neg. 510169

Figure 170. West German HK 21 machinegun.

c. The Heckler and Koch machineguns fire either 5.56x45-mm or 7.62x51-mm ammunition; refer to section V. The belt-fed models use Stoner '63 5.56-mm or US M13 7.62-mm links.



Neg. 529188

Figure 170.1. West German HK 21A1 machinegun.

219. Technical Data

Technical data concerning the HK machineguns are given in table VII.

220. Operation

a. Operate the HK 13 or HK 21 with magazine adapter according to the directions in paragraph 146.

b. The HK 21 (belt fed) and HK 21A1 are loaded by first pulling the operating handle rearward and turning it up into the safety notch (fig 170). If the weapon is an HK 21, press the feed catch and pull the feeder out to the left. CAUTION: As soon as the feeder moves, release the catch; otherwise, the feeder will come out of the gun. Place the ammunition belt on the feeder with the link opening up and the first round engaged in the feed sprocket (fig 171). Hold the belt in place and force the feeder back in until it latches. If the gun is an HK 21A1, press the feeder catch and allow the feeder to drop (fig 171). Then place the belt on the feeder as described above, and swing the feeder up until it catches in place or, without opening the feeder, insert the tab end of a feed belt into the feeder, open side of the link up, and pull tab hard to right (fig 171.1).

c. Pull the operating handle (fig 170) to the rear slightly, rotate it down, out of its safety recess, and release it. CAUTION: The machinegun is now ready to fire. If the gun is not to be immediately fired, rotate the safety to its highest position.

d. Best results are obtained by use of the bipod. Pull the legs away from the barrel jacket until they lock in place. The legs are folded by pressing the locks (fig 169) and then folding the legs rearward. Set the sight for the desired range by rotating the elevation knob (fig 169) until the desired range, in hundreds of meters, appears in the window alongside the knob.

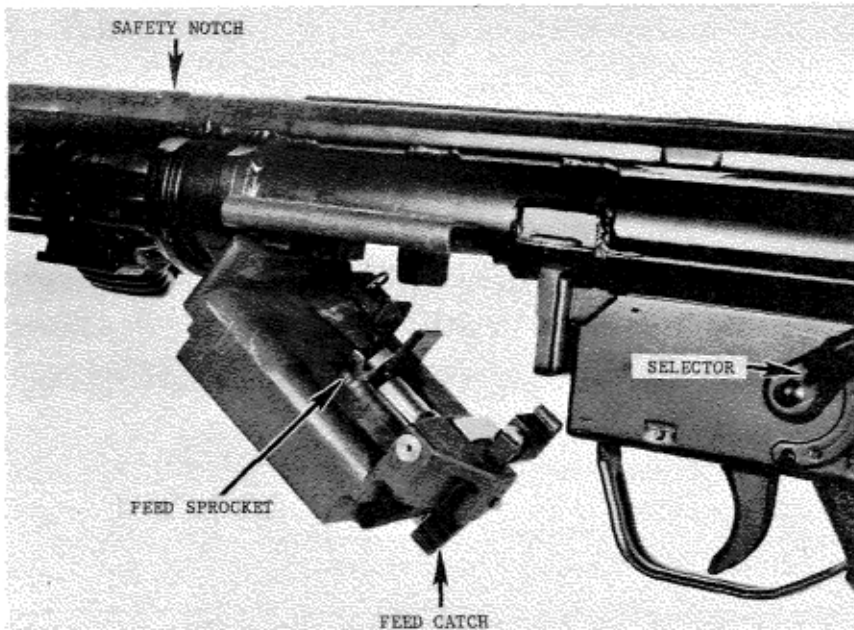

Neg. 510170

Figure 171. West German HK 21A1 feeder.

e. To fire, rotate the selector to the desired position (mid for semiautomatic and bottom for full automatic), aim (using a normal sight picture), and press the trigger. Best results in automatic fire are obtained with three to five shot bursts. The bolt will remain forward.

f. If the weapon is either an HK 21 or an HK 21A1, clear or unload it by rotating the selector up to the safe position, pressing the feeder catch and pulling the HK 21 feeder to the left or allowing the HK 21A1 feeder to drop. Lift the belt off the sprocket, and then close the feeders, insuring that they are caught by the feeder catches. If the gun is an HK 13, proceed as directed in paragraph 146g.

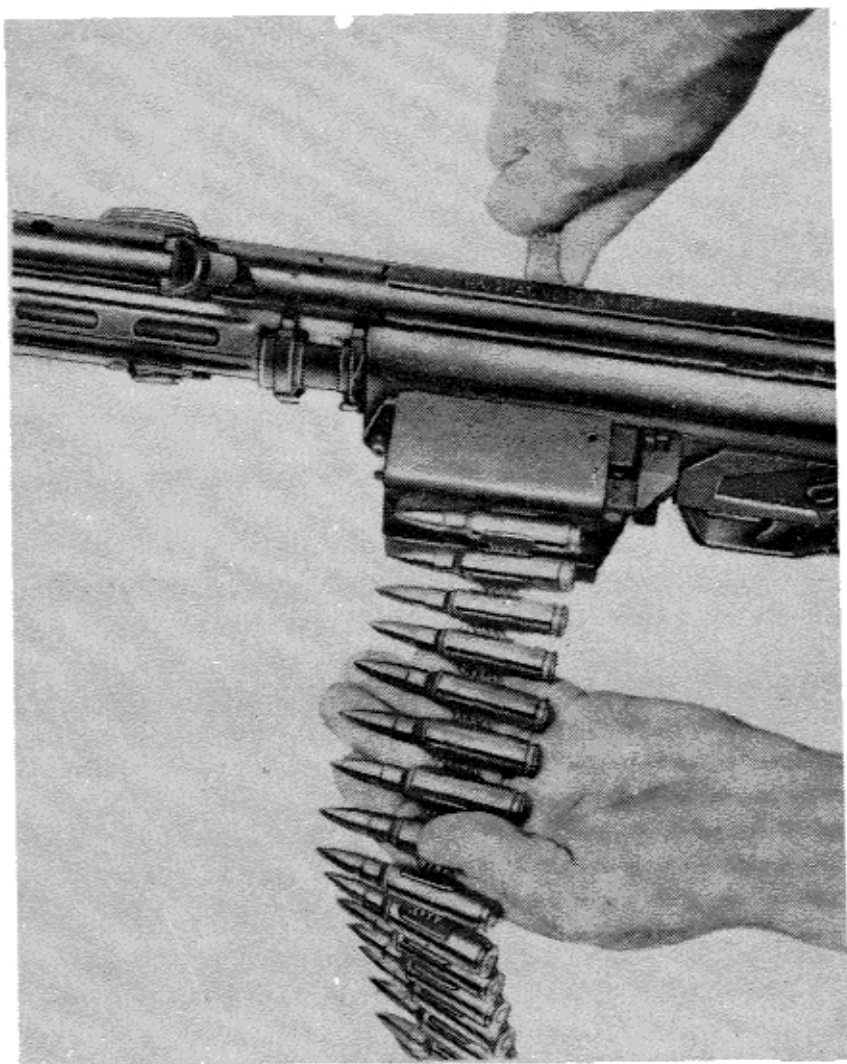

Neg. 529189

Figure 171.1. Inserting feed belt with feed tab;
feeder closed.

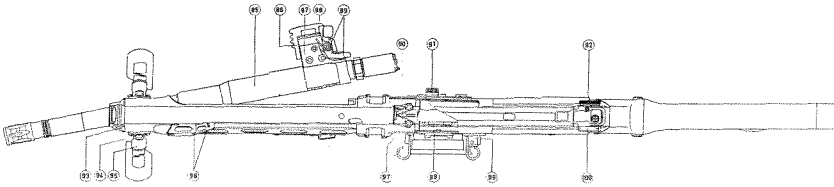

Neg. 510171

- | | |
|----------------------------------------|-------------------------------------------|
| 85. Barrel | 94. Set bolt |
| 86. Barrel grip | 95. Left bipod leg |
| 87. Spacer | 96. Operating handle
with elbow spring |
| 88. Grip holder | 97. Locking roller |
| 89. Barrel catch with
elbow spring | 98. Bolt head locking
lever |
| 90. Extractor with
extractor spring | 99. Protective cap |
| 91. Catch | 100. Scale drum |
| 92. Range drum | |
| 93. Eye bolt | |

Figure 172. HK 21 barrel change.

g. To change barrels, pull the operating handle to the rear and turn it up into the safety notch. Grasp the barrel handle (fig 169) and, at the same time, press the catch at the back of the handle (fig 169). Rotate the handle up, and then shove the handle and barrel forward. Pull the handle to the side and remove the barrel to the rear. Insert the flash hider of the new barrel into the hole in the front of the barrel jacket and push the barrel forward until it can be placed inside the jacket; then, with the handle up, pull the barrel back into the receiver. Rotate the handle down until the catch snaps into place.

221. Disassembly and Assembly

a. Disassemble and assemble the HK 13, HK 21, and HK 21A1 as described in paragraph 147a through h.

b. The feeder of the HK 21 can then be removed by pressing the feeder catch and pulling the feeder out to the left while holding the catch. Reverse this operation to install the feeder.

222. Functioning

a. The basic functioning of the HK 13, HK 21, and HK 21A1 is identical to that of the G3 rifle (refer to paragraph 148 and figure 173).

b. The bolt carrier of the HK 21 and HK 21A1 has a diagonal slot cut across its bottom side to actuate the belt feeder. As the bolt carrier recoils and counterrecoils, this slot causes a roller stud in the feeder (fig 174) to move from side to side. This side-to-side movement actuates a ratchet mechanism on the end of the sprocket (fig 174) to revolve the sprocket. A pawl prevents counterrotation and, as the sprocket rotates, it places fresh cartridges in position for the bolt feed rib to pick up and bring into the chamber.

223. Accessories

a. The accessories used with the G3 rifle (para 149) can also be used on the machineguns.

b. The telescopic sight is attached by seating its right side over the ridge on top of the receiver, then swinging its left side down over the receiver and rotating the lock lever until the lever fits into place.

c. The HK 21 and H21A1 have a plastic ammunition box that can be attached to the lugs in front of the receiver.

F. THE 7.62-MM MG-1/MG-3 MACHINEGUN (WEST GERMANY)

224. General

a. The predecessor of the MG-1, the MG-42, was developed in Germany during World War II as a replacement for the complex, undependable, and expensive MG-34. Like the MG-34, the MG-42 is belt fed and recoil operated, but the MG-42 is constructed largely of stamped sheet metal, as contrasted to the intricately forged and machined MG-34. The MG-42 gave excellent performances, from the sandy tropic deserts to the cold, snowy, northlands. It was an uncomplicated and fairly trouble-free machinegun. Production of the MG-42 halted at the end of World War II, but in 1959 production was resumed by the Rheinmetall Corporation of West Germany.

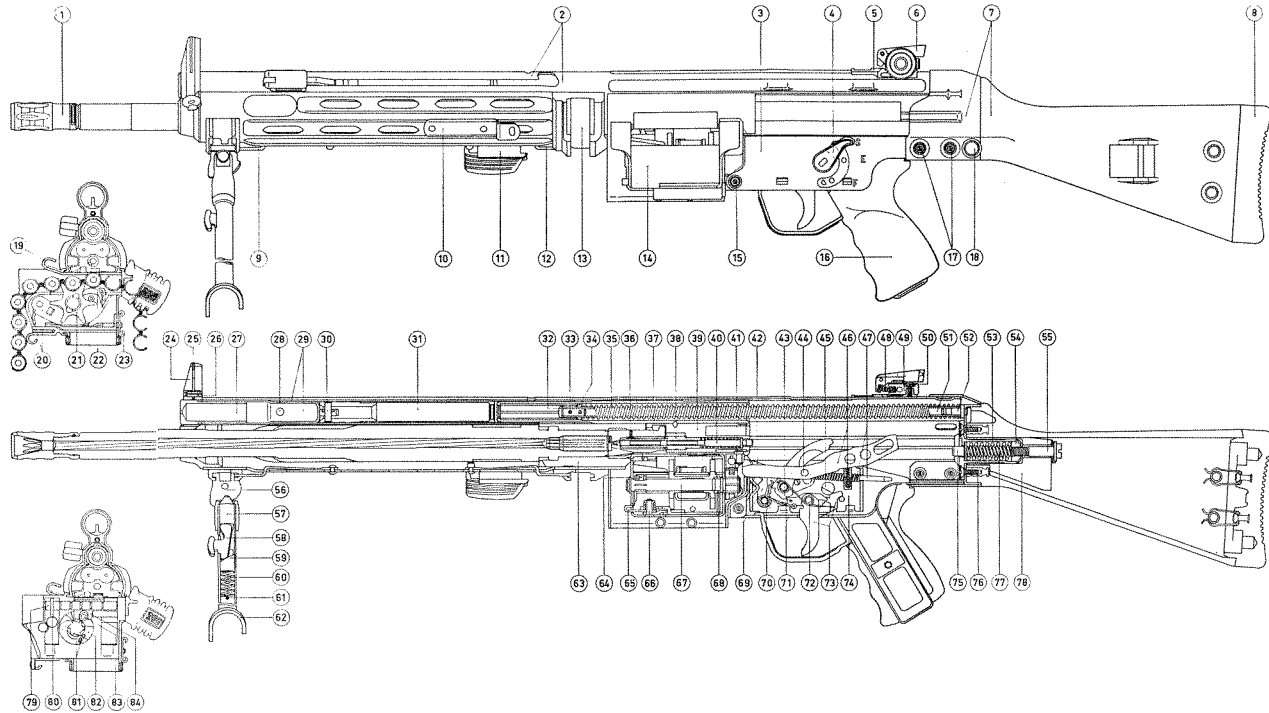

Нес. 510172

Figure 173. H21 section.

- | | | |
|------------------------------------------------------------------|----------------------------------------------------|------------------------------------|
| 1. Flash suppressor (with retaining spring for flash suppressor) | 29. Stop abutment with operating housing | 55. Buffer screw |
| 2. Receiver with barrel jacket | 30. Operating handle spindle | 56. Bipod head |
| 3. Grip assembly | 31. Operating handle support with collar tube | 57. Blocking pin |
| 4. Selector | 32. Stop pin for recoil spring | 58. Catch lever |
| 5. Sight base | 33. Clamping sleeve for recoil spring stop pin | 59. Spring pin |
| 6. Sight arm | 34. Recoil spring guide ring | 60. Spring for spring pin |
| 7. Butt stock with back plate | 35. Recoil spring | 61. Clamping sleeve |
| 8. Butt plate | 36. Clamping sleeve and holder for locking rollers | 62. Left spike |
| 9. Leaf spring | 37. Bolt head | 63. Barrel extension |
| 10. Sling holder | 38. Locking piece | 64. Retaining catch |
| 11. Field mount attachment | 39. Bolt body | 65. Catch lever |
| 12. Leaf spring | 40. Firing pin with firing pin spring | 66. Catch lever spindle |
| 13. Bipod attachment | 41. Cam roller | 67. Transport spindle |
| 14. Belt feed insertion unit | 42. Release lever | 68. Driver |
| 15. Grip assembly locking pin | 43. Hammer | 69. Catch |
| 16. Grip | 44. Ejector spindle | 70. Trigger lever |
| 17. Butt stock locking pins | 45. Safety pin | 71. Elbow spring and roller |
| 18. Pivot for field mount | 46. Ejector with pressure spring | 72. Elbow spring for trigger |
| 19. Cartridge guide | 47. Pressure shank with pressure spring | 73. Trigger |
| 20. Spring bearing (with elbow spring) | 48. Pressure spring for sight arm | 74. Trigger assembly housing |
| 21. Transport wheel | 49. Sight support | 75. Buffer pin |
| 22. Pressure roller | 50. Fixing screw with toothed washer | 76. Selflocking countersunk screw |
| 23. Locking plate | 51. Recoil spring guide rod | 77. Buffer spring, inner and outer |
| 24. Front sight holder | 52. Recoil spring guide rod pin | 78. Buffer housing support |
| 25. Front sight | 53. Buffer housing | 79. Slide spindle |
| 26. Clamping sleeve for front sight | 54. Buffer locking screw | 80. Cylindrical pin |
| 27. Retaining sleeve | | 81. Pawl with pressure spring |
| 28. Stop pin | | 82. Ratchet ring |
| | | 83. Rivet pin with roller |
| | | 84. Slide |

Figure 173. H21 section. (Continued)

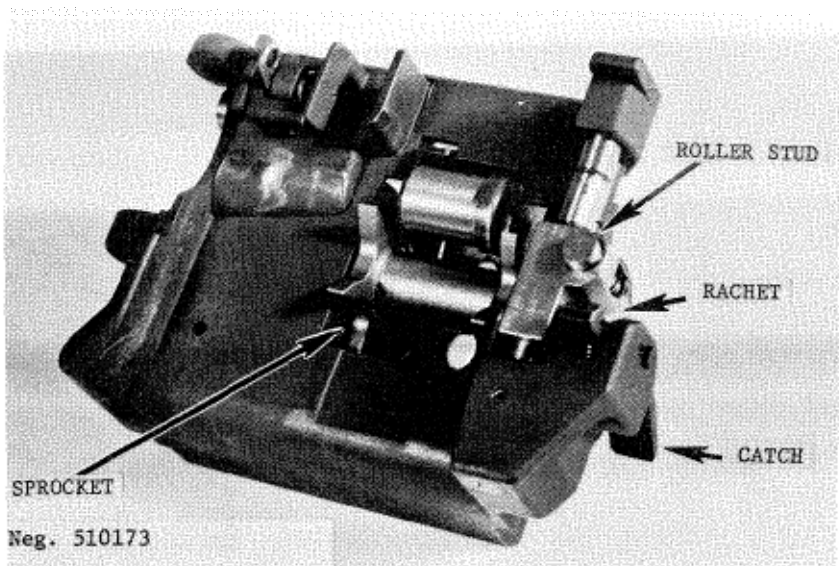

Figure 174. HK 21A1 feeder mechanism.

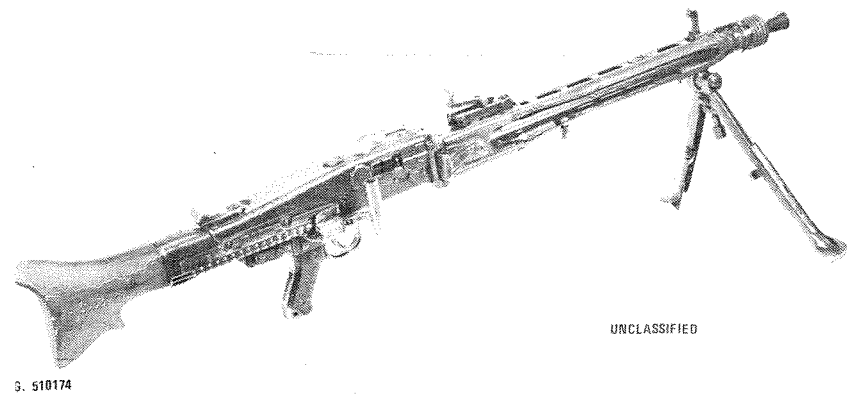

Figure 175. Old German MG 42 machinegun.

b. The Rheinmetall gun is known either by its commercial designation of MG-42/59, or by the West German Military designation of MG-1 (fig 176). There are several variations of the MG-1. The original MG-1, in 7.62x51-mm NATO, was almost identical to the old MG-42; the MG-1A1, chambered for the

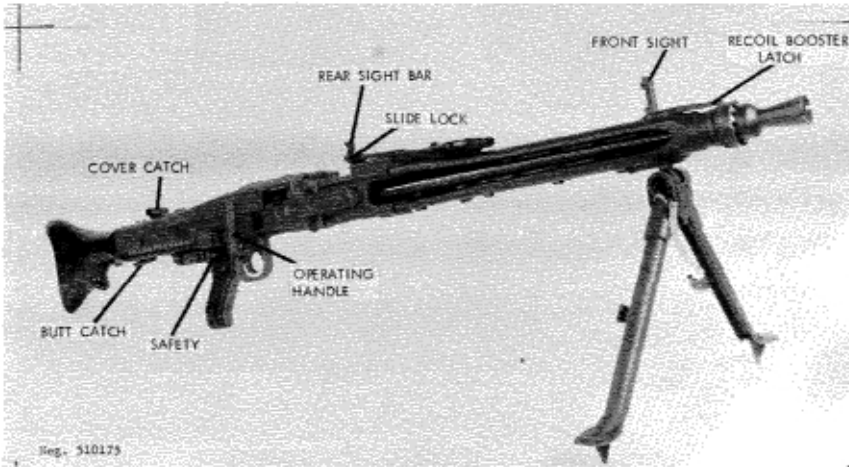

Figure 176. West German MG1 or MG3 machinegun.

7.62x51-mm NATO cartridge, had a chrome-plated barrel bore; the MG-1A2 has several minor modifications and can be fed with either the German 50-section belt or US M13 links. The MG-1A3 also has several minor changes, most of which were made to simplify production. The latest version, the MG-3, has an anti-aircraft ring sight and a device to prevent the belt from falling out of the gun when the cover is opened. The Yugoslavs also produce a copy of the original MG-42 (fig 175) in 7.92x57-mm; they call their gun the SARAC M-1953. The MG-42/59 is used by Austria, Denmark, Spain, West Germany, and Italy (the latter two countries also manufacture the gun); many smaller nations also use various versions of the MG-42.

c. The origin of the gun can be determined by the receiver markings, which are normally found in the left side of the receiver just ahead of the butt stock.

d. The original MG-42 had a very high cyclic rate (from 1100 to about 1200 rounds per minute), but by exchanging some parts, the MG-42/59 and MG-1 series can be set to fire either 550 or 950 rounds per minute. The modern versions are used in tanks and armored personnel carriers as well as by infantry. The World War II MG-42 and the SARAC M-1953 guns fire the 7.92x57-mm cartridge; the MG-42/59, the MG-1, and the M63 fire the 7.62x51-mm NATO cartridge (sec V).

225. Technical Data

Technical data concerning the MG-1 are given in table VII.

226. Operation

a. The ammunition belt is constructed from semicircular links held together by a spiral connector. Only this belt can be used with the MG-42, MG-1, or SARAC 53. If the gun is an MG-1A2 or later modification, ammunition belted with US M13 links, such as those used in the US M60 machinegun, can be used. Load the belt by pressing a cartridge into each link until the tab on the link snaps into the groove of the cartridge case. Long belts can be made by seating the last or connecting link of one belt into the first link of another belt and locking them together by inserting a cartridge. If a leading tab is not available, leave the first few links empty to serve as a leading tab.

b. Grasp the operating handle (fig 176), pull it fully rearward, and then thrust it forward. This cocks the gun's mechanism. Press the safety (fig 176) fully to the left to lock the gun in its safe position.

c. If the gun is an MG-42 or an SARAC M-1953, press in the bipod latch and pull the bipod down into position; its legs will spring apart automatically. All other guns have a spring clamp to hold the bipod; simply pull the bipod away from the receiver.

d. If the feed belt does not have a feed tab, the cover must be opened. Press the cover catch (fig 176) forward and swing the cover up and forward. Place the belt so that the first cartridge rests against the stop (fig 177) in the feed tray and the belt or link is between the stop and inner rear edge of the feed tray. Close the cover. The barrel should be changed after each 150 rounds (three belt sections) of continuous fire. To change barrels, pull the operating handle to the rear. Push forward on the barrel-cover lock (fig 177) until the barrel cover swings out. The rear end of the barrel will be pulled out of the receiver, and it can then be easily removed to the rear. (CAUTION: The barrel may be hot.) Thrust a cool barrel into the jacket as far as it will go and close the barrel cover. Insure that the barrel cover lock is caught, push the operating handle forward, and resume fire.

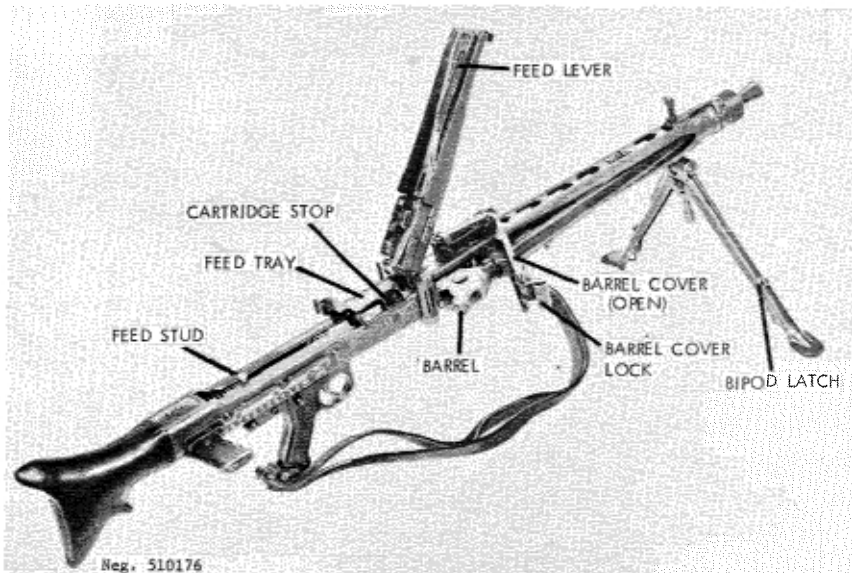

Figure 177. MG 42, MG1, MG3 barrel change.

e. To clear or unload the gun, pull the operating handle to the rear, press the safety to the left, and open the cover (para d above). Lift the belt and any empty links from the feed tray. Remove the barrel (g above), inspect it to insure that no cartridges are present, and replace the barrel. Inspect to insure that no cartridges are present in the feed tray or receiver, and close the cover. Press the safety to the right, grasp the operating handle, press the trigger, and ease the bolt forward. Close the ejection port cover under the receiver by pressing it up against the ejection port. Reset the safety to the left, fold the front and rear sights down, squeeze the bipod legs together, and fold the bipod to the rear until it locks to the receiver.

227. Disassembly and Assembly

a. To disassemble the weapon, clear the gun (para 226e), but do not fold the bipod; leave the safety pushed to the right. Leave the cover open.

b. Press the butt catch (fig 176) and rotate the butt while pushing it in against the force of the driving spring. The butt will disengage from the receiver; ease the butt away from the receiver. Pull the driving spring out of the receiver.

c. Holding a hand over the opening at the rear end of the receiver, grasp the operating handle, give it a sharp jerk rearward, and then push it forward. This action moves the bolt to the rear in the receiver; the bolt can be grasped and pulled out of the receiver.

d. Pull the locking rollers (fig 178) to the side in the bolt head; then twist the bolt head counterclockwise until it is free of the bolt body. The ejector actuator, locking cam, and firing pin can now be removed from the disassembled bolt. Note: Some guns have a powerful spring housed in the bolt body; use care when twisting the bolt head.

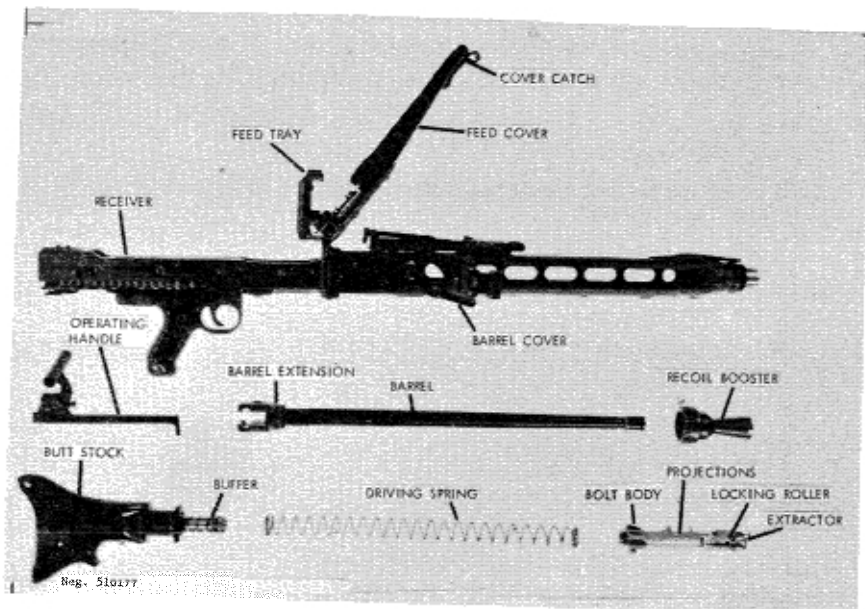

Figure 178. MG-1 disassembled.

e. Lift the recoil-booster latch (fig 176) and unscrew the recoil booster; thoroughly clean it of carbon and firing residue. Remove the barrel (para 160g) and thoroughly clean it. Reinstall the barrel, and screw the recoil booster back onto the front of the receiver.

f. To reassemble the gun, insert the flat end of the firing pin into the locking cam and place the locking cam into the bolt head. Slip the ejector into the bolt body. If the bolt has an internal spring and plunger, install these parts with the plunger toward the narrow end of the ejector actuator. Place the bolt head over the bolt body and twist the bolt head so that the extractor is in line with the double projections (fig 178) on the bolt body.

g. Insert the assembled bolt into the receiver, extractor down; pull the trigger and push the bolt as far forward as possible.

Insert the driving spring into the receiver and use the spring to push the bolt fully home. Slip the buffer (fig 178) into the driving spring. Hold the butt twisted to 90° and insert its threaded section into the receiver; rotate the butt until the butt catch snaps into place. Close the cover and press the safety to the left. Fold the bipod.

228. Functioning

a. The MG-1 is recoil operated.

b. The firing cycle starts when the trigger is pressed and the sear releases the bolt. The compressed driving spring forces the bolt forward, and as it goes, the feed rib on top of the bolt forces a cartridge from the belt into the chamber.

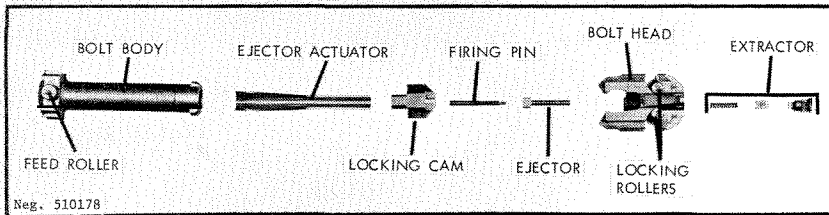

Figure 179. MG-1 bolt.

c. There is a locking roller (fig 179) on each side of the bolt head (fig 179); rails on the inside of the receiver hold the rollers in their inner position until the bolt head enters the barrel extension (fig 178). After the bolt head enters the barrel extension, the locking cam (fig 179) forces the locking rollers outward and into the locking recesses in the barrel extension. The firing pin is carried in the locking cam, and after the locking rollers are engaged with the barrel extension, the cam drives the firing pin into the primer of the cartridge and fires the cartridge.

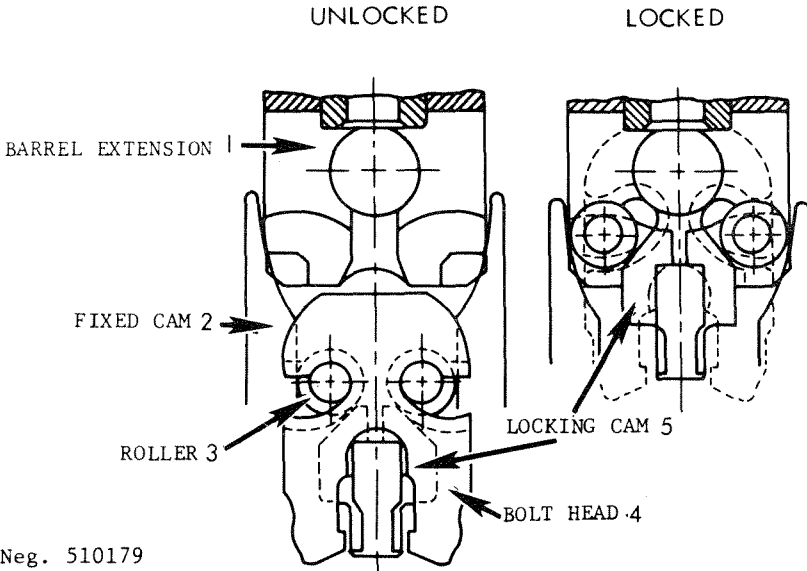
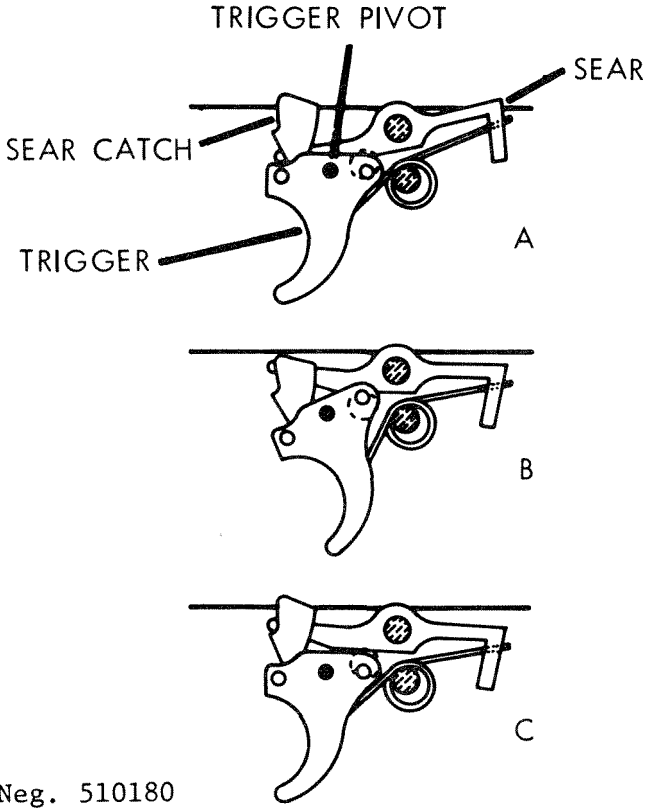

Figure 180. MG-1 bolt functioning.

d. The barrel, with the bolt locked to it, recoils within the receiver, compressing the barrel return and driving springs. After a short one-third inch travel, the locking rollers contact fixed cams (fig 180) in the receiver. These cams force the locking rollers inward; the rollers in turn force the locking cam, with the firing pin, rearward. When the rollers disengage from the barrel extension, the barrel return spring drives the barrel forward to its original position; the unlocked bolt continues to the rear. The extractor withdraws the fired cartridge from the chamber and holds it to the bolt face. The bolt continues to the rear until the ejector actuator strikes the buffer. This action forces the ejector out through the top of the bolt face and causes the cartridge case to pivot around the extractor, and to be expelled from the bottom of the gun. The bolt body then strikes the buffer, and all rearward movement stops.

e. The driving spring now forces the bolt forward to repeat the firing cycle, or if the trigger has been released, to be intercepted by the sear and thus to interrupt the firing cycle.



Neg. 510180

Figure 181. MG-1 trigger functioning.

f. The trigger mechanism (fig 181) of the MG-42 is simple. When the trigger is pressed, it pivots around its pin, and the rear of the trigger applies pressure to the front underside of the sear. This causes the sear to swing about its pin, and the rear of the sear depresses and releases the bolt.

g. The sear release is mounted on the front upper end of the trigger, and when the trigger is pressed, the sear catch is pulled down out of the path of the bolt. When it is fully depressed, the sear is held depressed, even when the trigger is released, because the sear catch swings forward over lugs on the front of the sear (fig 181B). When the trigger is released, the sear release rises up (fig 181C) into the path of the bolt; the bolt, going rearward, rocks the sear release to the rear, which releases the sear. This action prevents the partial engagement of sear and bolt that might occur if the trigger were slowly released, possibly causing chipping or breaking of the sear or bolt. The sear, when fully released, intercepts the bolt and halts the firing cycle. The safety is a simple push button that, when on safe, interposes a solid block under the tail of the sear and prevents the sear from being depressed. When at fire, a slot in the safety permits the tail of the sear to move downward, and the trigger can be depressed to fire the gun.

h. The recoil and counterrecoil movement of the bolt operates the feed mechanism. A long, curved belt-feed lever, pivoted at the rear end of the cover, has a channel running along its length. This channel fits over a roller or stud at the top rear of the bolt carrier (fig 179). As the bolt moves rearward in recoil (in a straight line), the roller causes the front of the curved belt-feed lever to move sideways. The belt-feed lever, in turn, operates an intermediate feed lever; this lever (fig 177) fits into the belt-feed slide and moves the slide back and forth. A spring-loaded feed pawl, mounted on the slide, rides on the ammunition belt and feeds it into the gun. The cartridges are held in the feed tray's feed slot by a cartridge hold-down; this part also serves a pawl to hold the belt in the gun.

229. Accessories

a. Numerous accessories are available for the MG-1 series guns. A heavy tripod, allowing the gun to be used in a heavy

machinegun role, is also available; the use of this tripod should be avoided because of the extensive training necessary to use this mount effectively.

b. Spare barrels, ammunition belts, and ammunition boxes normally will be available. In addition, a sling and a ruptured cartridge extractor are usually used. The extractor is placed in the chamber, and the handle is levered rearward. This will usually remove the remnants of the cartridge case.

G. THE 7.62-MM TYPE 62 AND TYPE 74 MACHINEGUNS (JAPAN)

130. General

a. The 7.62-mm Type 62 (fig 182) and Type 74 (fig 182.1) machineguns are the current standard automatic weapons of the Japanese Ground Self-Defense Force. These guns, of Japanese design and manufacture, are used only by the Japanese. The Type 62 and Type 74, while mechanically similar, are intended for different uses. The Type 62 is an infantry machinegun, while the Type 74 is intended for use on armored vehicles.

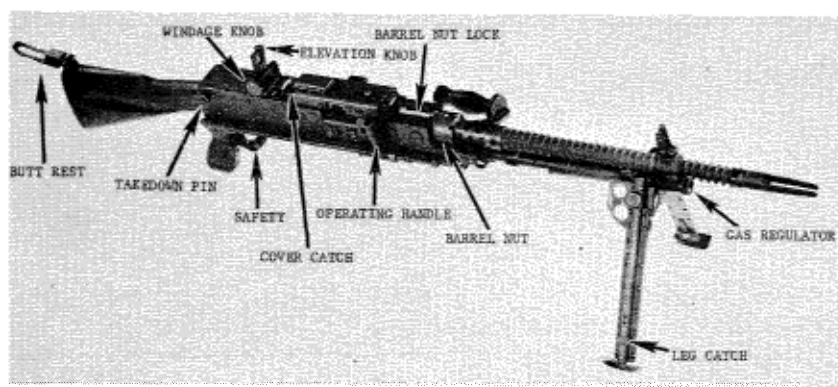

leg. 510181

Figure 182. Japanese Type 62 machinegun.

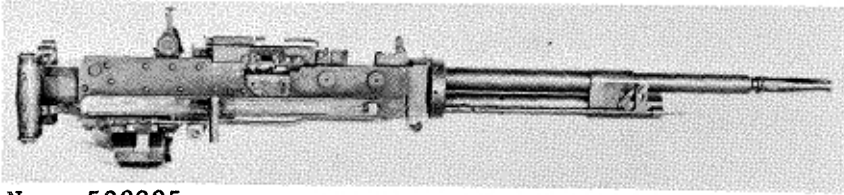

Neg. 528895

Figure 182.1. Japanese Type 74 machinegun.

b. The Type 62 machinegun can be identified by its general resemblance to the US M60 machinegun, but the Type 62 has prominent spiral cooling rings on its barrel and an odd, tubular, folding operating handle.

c. The Type 62 machinegun is a gas-operated, belt-fed, fully automatic weapon that normally is fired from its bipod but which can also be fitted to a light tripod. A straight tube telescope can be attached as an aiming aid (fig 183), and, when the weapon is fired from the tripod, a periscope sight is often used.

d. Current production Type 62 machineguns, (fig 183.1) can be distinguished from early production guns, primarily by the closed end flash suppressor on the late gun, as opposed to the open end suppressor on the early gun.

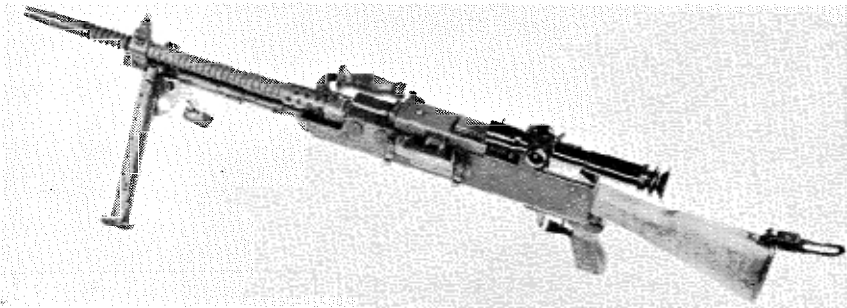

Neg. 510182

Figure 183. Type 62 with telescopic sight attached.

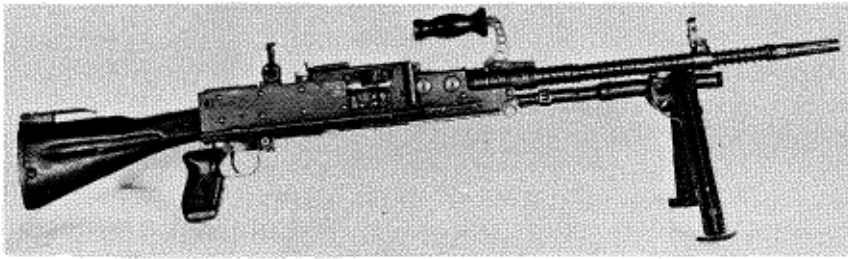

Neg. 528896

Figure 183.1. Current production Type 62.

e. The Type 62 machinegun fires 7.62x51-mm NATO ammunition (sec V) and uses the US M13 links for the feed belt.

f. The Type 74 machinegun (fig 182.1), while mechanically similar to the Type 62 machinegun, has no bipod, buttstock, pistol grip trigger mechanism, front sight, or cooling fans on its barrel. The Type 74 weapon does have twin spade grips with a mechanical trigger at the rear of the gun, an electrical trigger solenoid under the rear of the receiver, a nonfolding "T"-shaped operating handle, an armored vehicle mount adapter, and a heavy smooth barrel. A unique method of adjusting the gas regulator is provided (para 232g).

231. Technical Data

Technical data pertaining to the Type 62 machinegun are presented in table VII.

232. Operation

a. Before loading, if the bipod legs are folded, pull them away from the bipod head until they can be moved to their open position. The legs can be lengthened by pulling the feet out of the legs or shortened by pressing the catch (fig 182)

and pushing the feet back into the legs. Open the hinged butt plate by pulling it forward against its spring until it can be swung rearward.

b. Prior to loading the gun, insure that the bolt is forward (pull the trigger) and that the feed cover is closed. Push the double-loop end of a belt of cartridges into the feedway from the left, until the holding pawl engages. Unfold the operating handle (fig 182), pull it fully to the rear, then push it forward and turn it up.

c. If the gun is not to be immediately fired, render it safe by pulling the head of the safety (fig 182) out and then rotating it rearward.

d. To fire, adjust the sight for range by rotating the elevation and windage knobs on the rear sight to the appropriate setting, or choose the appropriate aiming mark in the telescope reticle. Pull out the safety head and rotate the safety forward; aim (using a normal sight picture), and press the trigger. Best results will be obtained with five-to-six-round bursts at a rate of 80 to 100 rounds per minute. This will permit 10 minutes of firing before the barrel must be replaced with a cool one. When releasing the trigger between bursts, do not ease it forward, but let it snap forward.

e. To unload or clear the gun, press the cover catch (fig 182) forward and swing the cover open. Lift the feed belt off the feed tray and return the belt to its container. Unfold the operating handle, pull it to the rear, and, while holding the handle, press the trigger and ease the handle forward. Close the cover; insure that the cover catch engages.

f. To change a hot barrel, unload (e above); as the cover opens, the barrel nut (fig 182) is unlocked and can be rotated by engaging the rear end of the carrying handle with one of the notches in the barrel nut. Turn the handle and nut as far as possible to the right, and then use the handle to remove the hot barrel from the gun. Seat the cool barrel fully into the nut, and then again use the handle to rotate the nut to the left. If the barrel nut lock (fig 182) is not aligned with its notch in the barrel nut, the cover cannot be closed. Close the cover and reload (b above).

g. If the Type 62 becomes sluggish, adjust the regulator. The regulator (fig 182) has three positions. The lowest setting can be used when the gun is broken in; new guns require the middle setting. Rotate the regulator to the lowest setting that will provide reliable functioning. If the weapon is a Type 74 machinegun, pull to the rear the small handle located to the right of the trigger solenoid. This handle is attached to a push rod with a yoke on its front end. The yoke is engaged with a crank on the gun's regulator, and movement of the handle and push rod will cause the regulator to rotate from one setting to the other. For normal use, the handle should be forward. If the gun will not function properly on the highest setting, it must be disassembled and cleaned.

233. Disassembly and Assembly

a. Clear the gun (para 232e) and remove the barrel (para 232f). Pull the operating handle rearward, and, while holding it, press the trigger and ease the mechanism forward.

b. Press the takedown pin (fig 182) from the right. Hold the stock group while doing this; it is

under spring pressure. Remove the stock and attached driving spring. Pull the operating lever to the rear until the bolt and slide (fig 184) can be grasped and pulled out of the receiver. Lift the bolt off the slide. The operating handle can be moved rearward until it comes off the receiver.

c. The piston and its spring (fig 184) can be pulled from the gas cylinder tube. If the piston is tight, engage the rim of a cartridge case in one of the grooves in the piston and pull it out. Rotate the bipod about 90° on the gas cylinder tube, until the bipod disengages from the shoulder on the gas cylinder, and pull the bipod off the gas cylinder tube.

d. Further disassembly is not necessary or desirable.

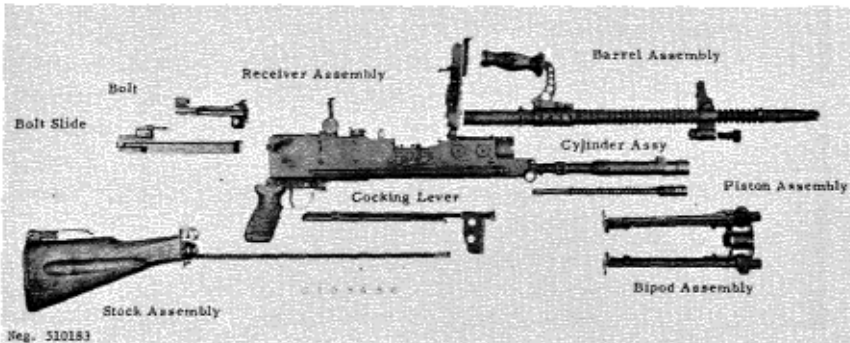

Neg. 510183

Figure 184. Type 62 disassembled.

e. To reassemble the Type 62, first slip the bipod onto the gas cylinder tube and rotate the bipod until it mates with the shoulder on the tube. Insert the piston and spring, spring first, into the gas cylinder tube.

f. Replace the operating handle over its guide. Place the bolt onto the slide and move the bolt forward on the slide. As the bolt moves, its front end should drop down. Insert the bolt and slide into the receiver. Insert the end of the driving spring (fig 184) into the hole in the slide, press the trigger, and push the butt stock into place in the receiver. Push the takedown pin (fig 182) into place. Replace the barrel (para 232f) and clear the gun (para 232e).

234. Functioning

a. The Type 62 machinegun is gas operated. The functional cycle starts with the bolt and slide to the rear, the driving spring compressed, and a cartridge in the feedway.

b. When the trigger is pressed, it rotates on its pin, and a forward extension of the trigger contacts the rear of the sear (fig 185). Continued pressure on the trigger forces the sear out of

engagement with the slide. The slide and bolt, under the force of the driving spring, start forward, and the feed rib on the bolt (fig 185) drives the cartridge in the feedway out of its link and into the chamber. The extractor engages the rim of the cartridge, and the bolt stops its forward movement when it contacts the barrel.

c. The slide continues forward, and a cam on the front of the slide forces the front end of the bolt upward into the locking shoulders of the receiver, locking the bolt. The slide continues forward, and the fixed firing pin (fig 185) strikes the cartridge primer and fires the cartridge. The firing pin support of the slide strikes the bolt, and forward movement ceases.

d. When the bullet passes the gas port in the barrel, some of the gases are vented off into the gas cylinder and drive the piston (fig 185) rearward, compressing the piston spring. The piston strikes the slide and drives the slide rearward; the piston then stops, and its spring returns it forward.

e. The slide travels to the rear, because of the momentum given it by the blow of the piston. After a short period of free travel, during which the firing pin retracts into the slide, cams on the slide contact the bolt and pull its front end down, out of the locking shoulders. A special cam on the slide locks the extractor to the fired cartridge case and, once the slide is unlocked, it moves to the rear with the slide. The slide compresses the driving spring. The extractor pulls the fired cartridge from the chamber and holds it to the bolt until the case strikes the ejector attached to the cover (fig 185) and is expelled down, out of the gun. The slide continues rearward until it strikes the buffer (fig 185) and stops; the driving spring then forces the slide and bolt forward to start another cycle.

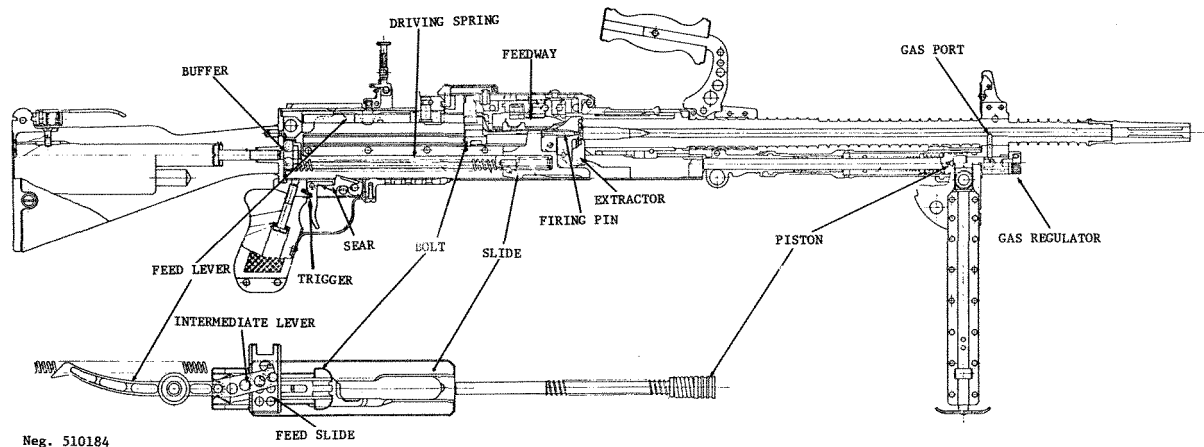

Neg. 510184

Figure 185. Type 62 section.

306

f. If the trigger is released, the sear, under spring pressure, moves upward and catches the slide, causing the gun to stop firing. The safety, when in the fire position, has a cutaway portion on its shaft that provides clearance for the sear (fig 185). When the safety is turned to the safe position, the solid section of the shaft prevents the sear from being depressed by the trigger. The slide thus cannot be released, and the gun is safe.

g. A set of guides on the rear end of the bolt fits along the sides of the belt-feed lever (fig 185) and causes the belt-feed lever to move from side to side. The front end of the belt feed lever is attached to an intermediate feed lever which, in turn, is attached to the feed slide (fig 185). The back-and-forth movement of the bolt during firing thus causes the belt-feed slide to move in and out of the feed cover. As the slide moves in, a set of spring-loaded pawls on the slide snaps over the next cartridge to be fired and, as the feed slide moves in, the pawls move the cartridge into the center of the feed tray where it can be picked up by the feed rib of the bolt. A spring-loaded holding pawl (fig 185) prevents outward movement of the feed belt when the feed slide moves outward.

235. Accessories

a. There are several major accessories used in conjunction with the Type 62 machinegun. These include a tripod mount, a sling, straight tube telescope, periscopic telescope, spare barrel, spare parts set, combination tool, cleaning rod, and ammunition belt boxes.

b. The telescopes are attached by sliding their bases onto the receiver until the retainer snaps into its seat. The telescopes are removed by pulling up the retainer and sliding the telescope off to the rear.

c. The gun is mounted on the tripod by fitting the rails just forward of the trigger onto the rear mount, then moving the gun forward on the mount until the pin can be inserted into the hole and the lower front of the receiver.

H. THE 5.56-MM MINIMI LIGHT MACHINEGUN (BELGIUM)

35.1. General

a. The 5.56-mm Minimi (fig 185.1) is a new multipurpose machinegun produced by Fabrique Nationale Herstal SA of Belgium. It is considered a complete weapon system because of its weight, size, ease of handling, and combat effectiveness (as evidenced by its high rate of fire and high hit probability). A derivative of the Minimi, the M249, has been type-classified for production by the US Army and Marine Corps.

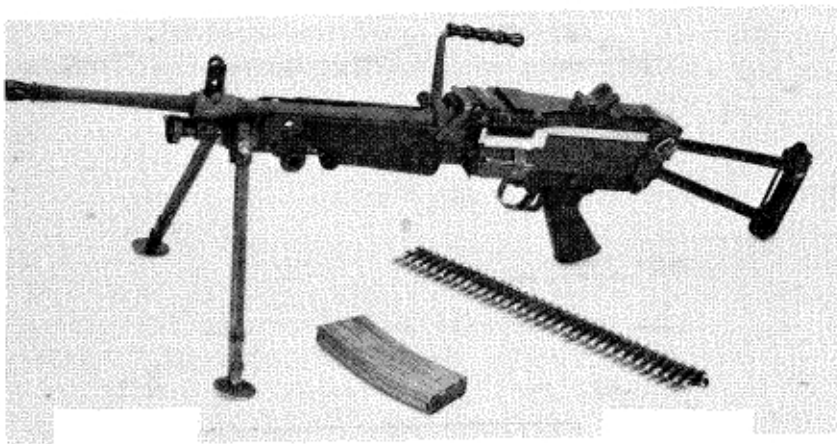

Fig. 527345

Figure 185.1. Belgian Minimi Light Machinegun

b. The weapon operates with an open breech-lock, a rotating bolt, two-position gas adjustment, and quick-change barrel capability. As a support

weapon, the Minimi can sustain a high rate of fire because it can be belt-fed. However, for those countries that prefer to use the Minimi as an individual weapon, a clip or magazine can be used.

c. The usual accessories for this weapon include: A blank-firing device on a flash-hider, a sling for carrying the weapon or firing it from the hip, a cleaning kit provided with the weapon, a sleeve for a grenade launcher, a tripod that can be used to increase firing accuracy or in defensive operations, 200-round ammunition boxes, and M16A1 magazines.

235.2. Technical Data

Technical data for the Minimi are provided in table VII, page 309.

235.3. Operation

No details are yet available. Data will be provided in the next update of this publication and/or through other publications.

I. MAINTENANCE

236. Care and Cleaning

The procedures and materials prescribed for cleaning standard US Army gas-operated machineguns also apply to foreign machineguns. These weapons should be disassembled only to the extent necessary for adequate cleaning to prevent breakage and subsequent loss of use. No repairs on foreign machineguns should be attempted other than the replacement of parts, and this should be done only by a competent armorer.

237. Malfunctions and Stoppages

See table VIII for common malfunctions and their remedies.

Table VII. Machinegun Technical Data

Weapon	MAG L7A1 ¹	Bren L4	AAT-52	M24/29	HK 13 HK 21	MG 1	Type 62	Minimi FN carbine
Caliber (mm)	7.62x51	7.63x51	7.5x54 ²	7.5x54	5.56x45 ²	7.62x51	7.62x51	5.56x45
Length (mm)	1255	1090	1133 ³	1082	1016	1125	1200	1012
Weight, empty (kg)	10.98	9.2	7.5 ⁴	9.2	6.95 ⁶ 7.9	11.0	10.7	8.36
Barrel length (mm)	568	544	492 ⁴	500	450	530	600	465
Barrel changeable	Yes	Yes	Yes	Yes ⁵	Yes	Yes	Yes	Yes
Feed device	Metallic belt	30-rd box magazine	Metallic belt	26-rd box magazine	40-rd box ⁶ metallic belt	Metallic belt	Metallic belt	100-rd box metallic belt
Operation	Gas	Gas	Delayed blowback	Gas	Delayed blowback	Recoil	Gas	Gas
Locking feature	Swing flap	Tilting bolt	None	Tilting bolt	Rollers	Rollers	Tilting bolt	Rotating bolt
Fire-type	Selective	Selective	Automatic	Selective	Selective	Automatic	Automatic	Automatic
Muzzle velocity (m/s)	820	815	850	850	970 ⁷	820	855 ⁸ 770 ⁹	930
Practical range (m)	1000	800	800	550	600	1000	1000	600
Rate of fire, practical (rd/min)	150-200	90-120	150	125	150	250	80-100	?
Rate of fire, cyclic (rd/min)	650-1000	500	700	500	850	700-1300	650 ⁸ 600 ⁹	750-1000
Mount type	Bipod or tripod	Bipod or tripod	Bipod or tripod	Bipod	Bipod	Bipod or tripod	Bipod or tripod	Bipod or tripod
¹ Data for M.A.G.		⁴ w/light barrel		⁷ 5.56x45				
² Also made in 7.62x51-mm		⁵ Not quick change		⁸ NATO round				
³ Stock extended, 972-mm folded		⁶ HK 13 only		⁹ Violet tip round				

Table VIII. Machinegun Malfunctions

Condition	Cause	Remedy
Fails to fire (cartridge in chamber)	Defective cartridge	Retract bolt and fire
	Weak driving spring	Replace spring
	Fouled weapon	Clean and lubricate
Fails to fire (no cartridge in chamber)	Defective magazine	Replace magazine
	Short recoil	Adjust gas regulator to next largest setting
	Short recoil	Clean and lubricate
Ruptured cartridge (repeatedly)	Excessive headspace, loose barrel, worn bolt	Adjust
Fails to extract	Dirty chamber	Clean
	Broken extractor	Replace extractor
Fails to eject	Fouled weapon	Clean and lubricate
	Short recoil	Adjust gas regulator
Runaway gun	Short recoil	Adjust gas regulator, lubricate

1
2
3
4
5
6
7
8
9
10
11
12
13
14
15
16
17
18
19
20
21
22
23
24
25
26
27
28
29
30
31
32
33
34
35
36
37
38
39
40
41
42
43
44
45
46
47
48
49
50
51
52
53
54
55
56
57
58
59
60
61
62
63
64
65
66
67
68
69
70
71
72
73
74
75
76
77
78
79
80
81
82
83
84
85
86
87
88
89
90
91
92
93
94
95
96
97
98
99
100

SECTION V. AMMUNITION

238. General

The ammunition used with free world weapons can be identified by comparing a cartridge with the outline drawing contained in ammunition identification guide (fig 186). Place the cartridge on top the drawing and examine the fit between the drawing and cartridge. If a small uniform line of white shows between the case and the drawing, and if each line on the cartridge case is substantially parallel with its corresponding line on the drawing, the cartridge can reasonably be expected to be that identified with the drawing and will fit the weapons listed. The ammunition for these older weapons can and does vary widely in quality, and samples should be test-fired to assure functioning. Gas regulators should be set to the smallest setting that will permit reliable functioning. Ammunition that is badly corroded, dented, or split in any portion of the case should not be used. Special-purpose bullets are marked various color codes. These bullets should be tested to ascertain their exact type.

239. References

For a more detailed discussion of small arms ammunition see the Small Caliber Ammunition Guide, DST-1160G-514-81-VOL 1, 2. Foreign small arms ammunition should be handled and preserved in the manner as prescribed for US small arms ammunition in TM 9-1305-200 (Small Arms Ammunition).



9 x 19.



11.43 x 23.



7.62 x 51.



7.5 x 54.



7.5 x 55.5.

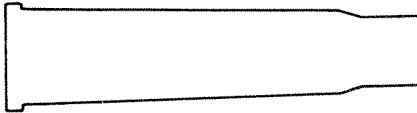

7.7 x 56R.



7.92 x 57.

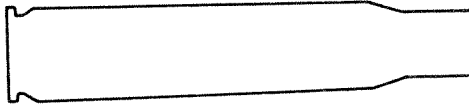

7.62 x 63.

Neg. 510185

Figure 186. Ammunition Identification Guide

PAPER COPYDISTRIBUTION BY DIA/RTS-2C

(397 Copies)

A086 NAT DEF UNIV (SCDC)
 A115 OASD ISA
 A117 OASD PA&E
 A125 OUSDRE
 A341 JCS/J-5 M/UN NEG
 B040 DIA/DIO
 B060 DIA/RTS-2A5 PENT
 B110 DIA/JS-CAJIT (A&T)
 B111 DIA/JS-CAJIT (O&I)
 B136 DIA/DE-3
 B150 DIA/DT
 B155 DIA/RTS-2A4 PP
 B169 DIA/DT-2D (2)
 B312 DIA/JSO-2
 B313 DIA/JSO-2A
 B239 DIA/JSO-1
 B352 DIA/RTS-2A2C STOCK (200)
 B361 DIA/DB-1B1A
 B363 DIA/DB-1B1B
 B364 DIA/DB-1B1C
 B501 DIA/OS-1
 B571 DIA/DB-4G1
 B607 DIA/DB-2B1
 B626 DIA/DB-3C1
 B628 DIA/DB-3D1
 B631 DIA/DB-3E1
 B663 DIA/DB-3B2
 B737 DIA/RTS-2B (LIB) (2)
 B798 DIA/DB-2D1
 B854 USDAO AUSTRALIA
 B855 USDAO AUSTRIA
 B873 USDAO DOMINIC REP
 B879 USDAO FRANCE
 B894 USDAO IVORY COAST
 B900 USDAO LEBANON
 B903 USDAO MALAWI
 B916 USDAO PHILIPPINES
 B918 USDAO PORTUGAL
 B926 USDAO SUDAN
 B928 USDAO SWITZERLAND
 D008 NISC
 D150 CMC (INT) (16)
 D247 NAVSURFWPCEN WOAK
 D947 NIC-522
 E749 HQ USAF/INZR
 P002 NPIC/REG (5)
 P055 CIA/OCR/DSD/SD (18)
 P085 STATE (106)
 P090 NSA (5)
 P175 US CUSTOMS SERVICE
 S030 FRD LIB OF CONG

DISTRIBUTION DIRECT TO RECIPIENT

(2948 Copies)

A305 JSOC
 A306 SFOD-D
 C003 DUSA(OR)
 C061 MP SCH
 C065 USAITIC-PAC
 C202 III CORPS
 C204 TCATA
 C231 2ND ARM DIV
 C234 1ST CAV DIV
 C235 1ST INF DIV
 C238 364TH MI CO (TI) (4)
 C239 11TH MI BN (PROV) (6)
 C241 FIRST US ARMY
 C300 172ND INF BDE (AK)
 C305 18TH ABN CORPS
 C306 82ND ABN DIV
 C307 24TH INF DIV
 C309 500TH MIG
 C314 513TH MIG
 C348 453D MID
 C351 10TH SFG(ABN)1STSF (20)
 C405 MTMC
 C414 4TH INF DIV
 C415 5TH INF DIV (M) (5)
 C417 7TH INF DIV (2)
 C419 9TH INF DIV
 C429 1ST BN(R) 75TH INF (5)
 C459 COMD-GEN STF COL
 C461 INFANTRY SCH
 C465 US MIL ACADEMY
 C470 ARMY WAR COL
 C500 TRADOC (2)
 C507 USAITAC (GIPD) (2)
 C587 CMBT DEV EXPR COMD
 C590 USATAC
 C605 JFK CTR MIL ASSIST
 C617 CONCEPT ANLYS AGCY
 C620 USAITAC (SRD)
 C639 CMBT&TNG DEV DIR (2)
 C667 USAIMA
 C683 INTEL CTR&SCH (4)
 C684 USAISD
 C715 ARMOR CTR (5)
 C763 HQDA DAMI-FIT
 C766 HQDA DAMI-FIC
 C768 USAITAC (LIB) (2)
 C786 HQDA DAMI-FIW
 C788 HQDA DAMI-FIS
 C801 SIXTH US ARMY
 D039 FOURTH MAW/MARTC
 D101 MCLB ALBANY (2200)
 DISTRIBUTION CODE L91

DISTRIBUTION DIRECT TO RECIPIENT Continued)

D152	NISC CBD DET 0003	<u>FSTC</u>
D224	MAG-49	
D246	NAVSURFWPNCEN DAHL	DRXST-IS3 (50)
D263	NOSC	DRXST-MT
D492	NAVSCOLEOD	DRXST-CA (50)
D583	FIRSTPAC 0919 (2)	DRXST-FS (3)
E411	ASD/FTD/NIIS	DRXST-ST2 (5)
E420	FTD/NIIS (2)	DRXST-IS1
E438	3480 TCHTG/TTVL	DRXST-IS2 (2)
E451	AUL/LSE	
E500	3420 TCHTG/TMMNL	
F059	1 SOS/IN	
H010	SOTFE (J-2)	
H101	USAFE 497RTG (IRC)	
H300	ODCS IN(USAREUR)	
H315	21ST SUPPORT COMD (2)	
H321	18TH MI BN	
H350	SFDET (ABN) EUR	
H524	HQ V CORPS	
H527	HQ 8TH INF DIV	
H528	1ST INF DIV (FWD)	
H529	HQ 3RD ARMORED DIV	
H530	HQ 1ST ARMORED DIV (2)	
H531	HQ 56TH FA BDE	
J435	COMNAVSPECWARGRU 2	
J436	COMNAVSPECWARU 2	
J515	FICEURLANT	
J522	COMNAVBASE GTMO (2)	
J586	UDT 21	
K005	CINCPAC	
K010	USFK	
K100	PACAF 548 RTG	
K115	5TH AF	
K120	326 AD/IN	
K300	IPAC (LIBRARY)	
K305	25TH INF DIV	
K314	IPAC (CODE PT)	
K340	CBDFLDARMY(ROK/US) (2)	
K342	2ND INF DIV (8)	
L040	SAC 544 SIW/DAA	
M005	USCINCSO	
M301	193RD INF BDE (PN)	
N005	USREDCOM	

DARCOM

C512	HQTRS DARCOM	DRCDE-FIO
C513	ARRADCOM	DRDAR-SEI (5)
C517	Benet Weapons Lab	DRDAR-SEI-W (2)
C509	Ballistic Res Lab	DRDAR-SEI-B (2)
C515	Chemical Sys Lab	DRDAR-SEI-C
C545	ARRCOM	DRSAR-ASB (10)
C697	Test & Eval Cmd.	DRSTE-TO-F (2)
C538	White Sands Msl Range	STEWS-TE-F
C522	YUMA PG	STEYP-FIO-CD
C505	AMMRC	DRXMR-XFI (2)
C619	MIA REDSTONE	DRSMI-YDL (6)

TOTAL DISTRIBUTION: 3345 Paper Copies

DISTRIBUTION BY DIA/RTS-2C (37 Copies) MICROFICHE

B329	DIA/JSO-1	B922	USDAO SENEGAL
B331	DIA/RTS-2A2	B924	USDAO SOUTH AFRICA
B352	DIA/RTS-2A2C STOCK (10)	B931	USDAO THAILAND
B738	DIA/RTS-2A1A AHS-A	B932	USDAO TUNISIA
B853	USDAO ARGENTINA	B937	USDAO VENEZUELA
B858	USDAO BRAZIL	B938	USDAO YEMEN
B866	USDAO COLOMBIA	B939	USDAO YUGOSLAVIA
B868	USDAO ZAIRE	B942	USDAO SINGAPORE
B870	USDAO CYPRUS	B944	USDAO BANGLADESH
B875	USDAO EL SALVADOR	B948	USDAO EGYPT
B878	USDAO FINLAND	D900	NAVOPINTCEN
B883	USDAO GUATEMALA	P002	NPIC/REG
B885	USDAO HONDURAS		
B888	USDAO INDONESIA		
B892	USDAO ISRAEL		
B914	USDAO PARAGUAY		

DISTRIBUTION DIRECT TO RECIPIENT (13 Copies)

C242	FORSCOM	C667	USAIMA
C500	TRADOC	C768	USAITAC (LIB)
C591	FSTC (ST1) (5)	C772	HQDA DAMI-FIO
C644	LOG CTR	H522	649TH ENGR BN (T) (2)

TOTAL DISTRIBUTION: 50 Microfiche Copies

This Page Intentionally Left Blank