

AD-099 317
RIA-81-U470
C-1507

~~CONFIDENTIAL~~
~~SECRET~~
DOWNGRADING DATA CANNOT BE PREETERMINED
(COPY NO. 48)

file 21198
Not Full Text

FUZE, VT, T2061 (U)

*Group 3 by
authority of DD254
on Fuze, VT, M414
(T2061E1) dtd 1/24/68*



USADACS Technical Library
5 0712 01003634 0

Regraded Unclassified
By authority of DTIC (A0099317)
Date 5 June 81



**TECHNICAL
LIBRARY**

AD 099 317

~~GROUP 3
DOWNGRADED AT 12 YEAR INTERVALS
NOT AUTOMATICALLY DECLASSIFIED~~

DESIGN RELEASE
30 JUNE 1955
REPORT TR-185
PROJECT TA3-6102

D. O. F. L.
027259
DOCUMENT CONTROL

TP
293
.037
1955

DIAMOND ORDNANCE FUZE LABORATORIES
ORDNANCE CORPS . . . DEPARTMENT OF THE ARMY

~~CONFIDENTIAL~~
~~SECRET~~

Oertel, Martin F.

Fuze, VT, T2061

#32553338

ORDNANCE FUZE LABORATORIES

John A. Ulrich, Lt. Col.
COMMANDING

W. S. Hinman, Jr.
TECHNICAL DIRECTOR

The Diamond Ordnance Fuze Laboratories is a Class II Ordnance installation under the Command of the Chief of Ordnance.

The mission of the Laboratories is as follows:

1. Conduct research and development in the various physical science and engineering fields directed toward meeting the military characteristics for fuzes and related items.
2. Provide consulting and liaison services as required in connection with the development, production, and use of items developed in the Laboratories or of related items.
3. Fabricate models and prototypes of items under development at the Laboratories.
4. Perform developmental testing, including destructive testing of prototypes.

The Diamond Ordnance Fuze Laboratories was established by the Ordnance Corps, Department of the Army, on 27 September 1953. The nucleus for these Laboratories was the personnel and facilities of the Ordnance Divisions of the National Bureau of Standards. The Diamond Ordnance Fuze Laboratories is now responsible for the fuze programs formerly conducted at that Bureau.

Typical fields of activity at the Diamond Ordnance Fuze Laboratories include electronics, physics, mechanics, chemistry and applied mathematics. Examples of topics in these activities are radiation and field studies, circuit theory and design, development and engineering of mechanical and electromechanical devices, chemical problems, and special electron tube design. The programs include all phases from basic research to product design.

AD- 099317

SECURITY REMARKING REQUIREMENTS

DOD 5200.1-R, DEC 78

REVIEW ON 30 JUN 75

THIS REPORT HAS BEEN DELIMITED
AND CLEARED FOR PUBLIC RELEASE
UNDER DOD DIRECTIVE 5200.20 AND
NO RESTRICTIONS ARE IMPOSED UPON
ITS USE AND DISCLOSURE.

DISTRIBUTION STATEMENT A

APPROVED FOR PUBLIC RELEASE,
DISTRIBUTION UNLIMITED.

UNCLASSIFIED

AD 99317

CLASSIFICATION CHANGED

TO UNCLASSIFIED

FROM CONFIDENTIAL

AUTHORITY:

HDL, D/A /tr,

20 MAY 80

~~CONFIDENTIAL~~

~~SECRET~~

THIS IS A 87 PAGE DOCUMENT

DIAMOND ORDNANCE FUZE LABORATORIES
DOFL PROJECT DOFL REPORT

WASHINGTON 25, D.C.

6106

TR-185

~~GROUP 3~~
~~DOWNGRADED AT 5 YEAR INTERVALS~~
~~NOT AUTOMATICALLY DECLASSIFIED~~

FUZE, VT, T2061

DESIGN RELEASE

(Ordnance Branch No. TA3-6102)

by: Martin F. Oertel

30 June 1955

This Document contains information affecting the national defense of the United States within the meaning of the Espionage Laws, Title 18, U.S.C., Sections 793 and 794. The transmission or the revelation of its contents in any manner to an unauthorized person is prohibited by law



ORDNANCE CORPS . . . DEPARTMENT OF THE ARMY

~~CONFIDENTIAL~~
~~SECRET~~

Approved by:

P. A. Guarino
Chief, Laboratory 20



VT. T-200

S.O. ON

 S.O. OFF

DEPARTMENT OF HEALTH

11 11 11

~~SECRET~~

~~CONFIDENTIAL~~

PREFACE

The Design Release describes the T2061 fuze at a stage in its development at which it appears to be capable of meeting the required Military Characteristics. Field evaluation and service-board tests of fuzes built in experimental production should precede release for full-scale manufacture, design improvements being made if necessary.

Detailed technical information covering the design, development and evaluation of the major subassemblies is presented in the following DOFL reports:

Fuze, VT, T2031E1, * Oscillator - TR-97
Fuze, VT, T2031E1, * Amplifier - TR-98
Fuze, VT, T2061, Battery - TR-186
Fuze, VT, T2061, Safety and Arming Mechanism - TR-187

* The T2061 fuze differs little from the T2031E1 in certain respects. It has therefore been deemed unnecessary to issue separate reports on some T2061 subassemblies.

~~CONFIDENTIAL~~

~~SECRET~~

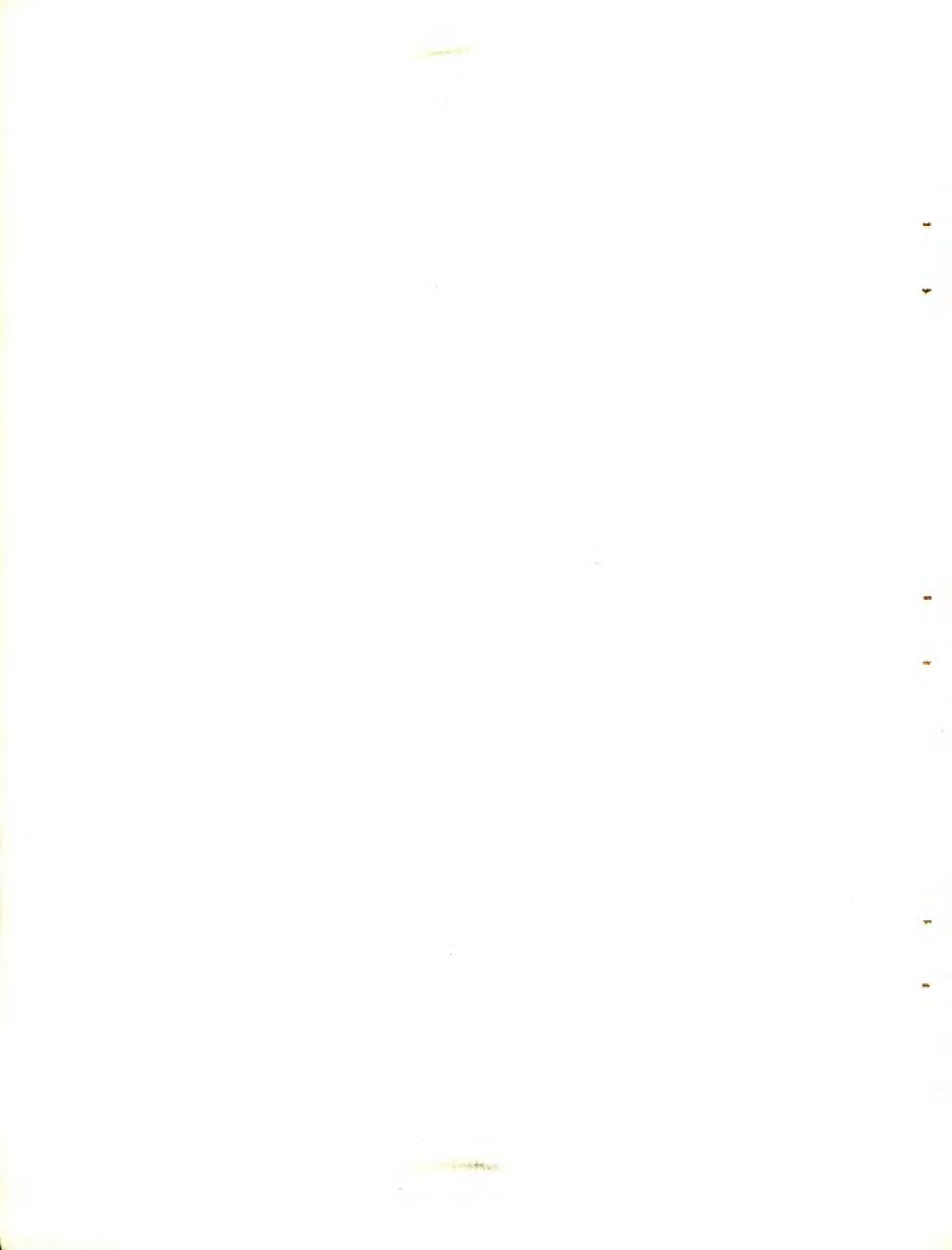

~~SECRET~~

~~CONFIDENTIAL~~

INTRODUCTION

The Design Release for Fuze, VT, T2031E1 for use on the 5-in. HVAR rocket was issued 30 June 1954 together with supplemental technical reports covering the oscillator, amplifier, battery, and safety and arming mechanism. Concurrent with preparation of the design release for the T2031E1, and in anticipation of a requirement that the fuze be operable when mounted on the 5-in. Zuni rocket, an investigation was initiated to determine if a modification of the electronic circuitry of the T2031E1 to adapt it for use with the higher velocity Zuni was feasible. The results of this preliminary investigation indicated that it was feasible to provide a fuze type suitable for use with the Zuni rocket without major redesign, and the nomenclature of T2061 was established for this fuze by OCM Item 35335.

The T2061 fuze was then developed for use on the 5-in. Zuni rocket, primarily for air-to-air application, but also for air-to-ground use. Although not intended for use with the HVAR rocket, the T2061 with the addition of a supplementary booster charge, should perform satisfactorily in air-to-ground applications with this rocket.

This release and referenced reports describe the background, the operation, test results and status of the fuze and its component parts.

~~CONFIDENTIAL~~

~~SECRET~~

~~SECRET~~

~~CONFIDENTIAL~~
1. MILITARY CHARACTERISTICS

The military characteristics for the T2061 fuze are defined in OCM Item 35632 dated December 1954. These characteristics and the degree of achievement are presented. The military characteristics are shown underlined at the beginning of each subparagraph.

a. Have the external configuration as shown in DOFL Drawing B300210 (thread size 2.000-12 NS-1RH, maximum intrusion, 2.980 inches).

The external contour of Fuze, VT, T2061 is in accordance with DOFL Drawing B300210 (depicted in Figure 1). It is designed to mount on either the Mk 24 or Mk 25 head for the Zuni rocket (Figures 2 and 3). The T2061 will replace Fuze, VT, M403 on the Mk 6 Mod 4 HVAR head with the addition of an auxiliary booster. The loaded weight of the T2061 fuze is 1195 grams of which 13.4 grams is the tetryl booster.

b. Detonate the warhead in air-to-air applications upon proximity approach to an aircraft under tail-attack conditions (radius of action on B47 type aircraft 30 feet to 45 feet; on fighter type aircraft 15 feet to 25 feet).

The amplifier section of the T2061 fuze has features intended to give controlled positioning of bursts when approaching an air target in tail-chase attack. The evaluation of its performance has been carried out with model-range techniques. The burst positions obtained in simulated tail-on attack on a B29 are described in Report DOFL R21-55-11, those against a Russian MIG-15 fighter in Report DOFL R21-55-9, and against the B47 class plane in Report DOFL R21-55-23. In general, operability is good out to approximately 40 to 50 ft on the B47 and 20 to 30 ft on the MIG-15.

c. Detonate the warhead in air-to-ground applications at a height for maximum casualty effect (tentative height at burst 40 ft \pm 20 ft above average ground over a range of approach angles from 10° to 50°).

Typical burst heights over ground ($n = 0.75$) are shown in Figure 4. The damage effectiveness zones shown are taken from 105-mm howitzer data.

~~CONFIDENTIAL~~

~~SECRET~~

~~SECRET~~

~~CONFIDENTIAL~~

d. Provide proper proximity function at a level as nearly 100 percent as practical under conditions of normal use.

- (1) in rain, fog or clouds
- (2) at altitudes up to 60,000 ft
- (3) at aircraft speeds from Mach 0.5 to 1.2
- (4) at temperatures from -65°F to $+160^{\circ}\text{F}$ (minimum acceptable -65°F to 125°F)
- (5) at relative humidities from 0 percent to 100 percent
- (6) when fired from multiple launchers (ripple firing as fast as practical without causing activation of the VT fuze from rocket ahead)

The quality level of the T2061 fuze is expected to exceed 90 percent under all conditions of normal use and under conditions specified except that performance may be adversely affected by ice, rain, snow or some type of clouds. No tests have been made under these conditions and therefore the quality level is unpredictable. Performance should be good over the temperature range from -65°F to $+160^{\circ}\text{F}$.

e. Embody safety features to insure a minimum safe air travel of 400 ft and withstand approved drop, jolt and vibration testing without becoming armed. The explosive train shall be interrupted in such a manner that initiation of the detonator will not result in initiation of the booster prior to normal arming.

The safety and arming mechanism will insure a minimum safe air travel of 400 ft under all firing conditions of the Zuni rocket. The primary safety latch is not released in less than 400 ft and impacting the rocket in this interval will not cause detonation of the explosive train. The explosive train is interrupted by a barrier plate which is released at the end of burning of the rocket propellant. A limited number of mechanisms have been subjected to drop, jolt, and vibration tests without becoming armed.

~~CONFIDENTIAL~~

~~SECRET~~

~~SECRET~~

~~CONFIDENTIAL~~

f. Embody an impact element capable of functioning upon impact in the event that proximity function does not occur.

An impact element is incorporated that will function upon impact with the ground or other object sufficient to cause 100 to 150 g deceleration of the round. The element actuates a stab primer and is independent of the functioning of the electronic and power supply portions of the fuze.

g. Embody maximum protection against enemy countermeasures or other interferences.

Protection from enemy countermeasures and/or other interference is good. There is high protection against noise and sweep jamming while the protection against repeater jamming is believed to be adequate. Extensive operational tests should be made to fully establish susceptibility to countermeasures.

h. Require no arming wire or electrical connections.

No arming wires or electrical connections are necessary.

i. Self-destroy with detonation of the warhead after 6 to 10 seconds of flight. The destruction element shall be simple to remove or inactivate.

A self-destruction element is incorporated which will detonate the booster charge after approximately 10 seconds of flight. It may be inactivated by a quarter turn of a slotted shaft on the side of the fuze prior to inserting the fuze in the round.

j. Be capable of withstanding:

- (1) normal rough handling and shipping shocks
- (2) normal storage when suitably packaged without impairment of its capabilities, for a maximum period of 10 years (desired goal 20 years).

No tests have been conducted on a packaged fuze to date. In a suitably designed package (hermetically sealed can) no difficulty is

~~CONFIDENTIAL~~

~~SECRET~~

~~SECRET~~

anticipated in meeting handling and shipping shocks and storage under extreme weather conditions. The storage life of the battery in the fuze is difficult to predict but it is believed that it and other fuze components can meet the minimum requirement of 10-year storage life.

2. FUZE DESCRIPTION

Fuze, VT, T2061 consists of four functional sections within its encasing hardware (Figure 5): an r-f oscillator, an amplifier and electric firing circuit, a reserve-type battery, and a safety and arming system with associated explosive train.

When the fuzed round is accelerated by the burning of the rocket propellant, the arming mechanism starts its cycle. If acceleration is sustained for the proper time, a firing pin is released to activate the battery. If acceleration continues to a minimum of 400 ft of air travel, the primary latch on the explosive train barrier is released and the fuze is committed to arm. When acceleration decreases at the end of burning, a secondary latch releases the barrier plate and the explosive train is put in line and a short is removed from the electric detonator. The battery, meanwhile, has taken about 0.5 second from initiation to reach full voltage and the oscillator and amplifier attain full sensitivity in another 0.1 second. When the rocket acceleration ceases a deceleration-activated switch in the amplifier section opens and allows a firing capacitor to charge through a resistance. This capacitor is fully charged in 0.1 second after acceleration ceases and the fuze is fully armed.

The fuze employs a loop antenna having a figure-8 pattern with maximum sensitivity normal to the rocket axis. The doppler signal resulting from approach to a target (aircraft or ground) is amplified and applied to an integrating circuit. After a suitable number of cycles a thyatron is fired, discharging the firing capacitor through the electric detonator which in turn initiates the explosive train.

2.1 Oscillator

The T2061 oscillator is of the reaction-grid-detection type using an N67 subminiature triode tube. The antenna used is a single-turn transverse loop which acts both as a magnetic dipole and as the high-Q resonant circuit in a Colpitts type Class C oscillator. This system provides

~~CONFIDENTIAL~~

~~SECRET~~

electrical independence of the fuze from the missile and radiation characteristics suitable for use in both air-to-air and air-to-ground applications.

The T2061 oscillator is identical with that used in the T2031E1 fuze which is described in full in DOFL Report TR-97.

2.2 Amplifier

The T2061 amplifier (the FLAF7) is a differential-integrator type designed to respond to the manner in which the amplitude, frequency and envelope rise time of the doppler-signal are interrelated. The circuit provides burst positioning for air-to-air application, control of burst height in air-to-ground use, and immunity to noise and interfering signals. The unit performs electrical arming as well as the fuze sensitizing functions.

The design of the FLAF7 amplifier is very similar to that of the FLAF6 used in the T2031E1 fuze, which was covered in detail in DOFL Report TR-98. The two are schematically the same. For the Zuni application, however, the integration time delay was reduced, and the cut-off frequency of the first amplifier stage was increased to provide proper operation at the higher rocket velocity.

Model-range evaluation of the FLAF7 indicates good burst positions out to 50 ft against a B29 and to about 20 ft against a MIG-15. Data on function heights in air-to-ground application are shown in Figures 4 and 6.

The T2061 circuit diagram and component values along with graphs showing technical details of amplifier performance are given in Appendix A, page 41.

2.3 Battery

The T2061 battery (Figure 7) is of the thermal reserve type comprising separate A, B, and C sections capable of operating over a temperature range of -65° to $+160^{\circ}$ F. The sections are made up of individual cells composed of metal electrodes and solid salt electrolytes, the latter becoming molten from heat supplied by a pyrotechnic composition

~~CONFIDENTIAL~~

surrounding the cells. The battery is initiated by a percussion-type primer, which is set off by an explosive-activated striker in the arming mechanism.

The background, design criteria, and performance characteristics of the T2061 battery together with the results of laboratory tests are described fully in DOFL Report-TR-186. The unit is an advanced version of the T2031E1 battery, with improved over-all performance and increased producibility and reproducibility. In general, the activation times, life and noise now fall consistently within the acceptable ranges. Typical voltage output curves are shown in Figure 8.

The over-all improvement in the T2061 battery over the T2031E1 battery is attributable to a series of refinements in materials, processing, and design. The major design changes are two: the individual B cells are now formed into a continuous spiral rather than in the layers of rings that required interconnecting welds; and the size of all the cells have been reduced permitting the use of more thermal insulation.

2.4 Safety and Arming Mechanism

The T2061 safety and arming mechanism (Figure 9) is a self-contained unit (no arming wires required) that operates only on the setback forces characteristic of the rocket. The unit is an acceleration integrating device that provides initiation of the VT power supply and arms on the deceleration at the end of rocket propellant burning. An independent self-destruction element and an impact element are included.

The background, design criteria and physical characteristics of the T2061 safety and arming mechanism together with the results of tests are covered in detail in DOFL Report TR-187. The T2061 safety and arming mechanism is a revision of the T2031E1 mechanism, and operates equally well in Zuni and in HVAR rockets. The inherent safety feature that causes the unit to fail safe if parts of the delay train are damaged or missing has been retained.

The major improvements in the present mechanism include the use of a rotor barrier, which replaces the shutter barrier of the T2031E1 mechanism; a one-piece aluminum main frame plate and

~~CONFIDENTIAL~~

~~SECRET~~

detonator block instead of the two-piece brass and steel unit; and an assembly clip to hold battery and mechanism together. During the development a comprehensive engineering study resulted in relaxed tolerances, use of less critical material, and simplification of fabrication. The unit therefore lends itself more readily to production techniques.

In the final testing of 180 fuzed rounds, only one malfunction occurred that could be attributable to the safety and arming mechanism.

2.5 Over-all Assembly

The design of the T2061 fuze case hardware and details of assembly on the complete fuze are covered in Report DOFL R22-55-9. Briefly the over-all assembly which is very similar to that of the T2031E1 fuze is as follows:

The contour is that shown in Figure 1. For interchangeability with the M403 for HVAR application the T2061 booster can be replaced by one of sufficient size to fill the cavity of the Mk 6 Mod 4 head.

The case hardware permits disassembly and reassembly without the use of machine tools or destruction of any major parts. The fuze assembly is shown in cross-section in Figure 10.

3. TEST EQUIPMENT

The set of test equipment recommended for use on the T2061 is identical with that for the T2031E1 fuze. A list of the Emerson Test Manuals covering these equipments is given in Appendix B.

4. FIELD PERFORMANCE

Field tests of the T2061 fuze were conducted during the period February 1955 through June 1955, except for one earlier test fired in May 1954. Some 294 fuzes built by Emerson and DOFL were fired in HVAR and Zuni rockets -- 23 launched from the ground at Blossom Point Proving Ground and the remainder from B26 and F80 planes at Aberdeen Proving Ground. The rounds had FLAF7 amplifiers, were powered by Pass and Seymour batteries, and used General Sintering

~~SECRET~~

~~CONFIDENTIAL~~

Company or Hamilton Mod 1 arming mechanisms. (The May 1954 test rounds had Catalyst reserve batteries and Raymond arming mechanisms.)

The detailed results are given in Table 1.

Discussion of Score

Based on the over-all results, there is a significant difference between the percentage of heard duds (0.0%) with fuzes having 0.005-in. thick or punctured diaphragms and that (9.1%) of fuzes having 0.015-in. thick diaphragms, indicating that at least some of the incidence of heard duds is attributable to failure of the tetryl lead to initiate the booster through the 0.015-in. diaphragm. Within each of the above groups, there is no significant difference between the percentage of proper functions with respect to arming mechanism, fuze manufacturer, rocket, launching (air vs ground), or approach (water vs target). The over-all percentages are as follows:

<u>Diaphragm</u>	<u>No. of Rounds</u>	<u>Pw</u>	<u>I</u>	<u>E</u>	<u>M</u>	<u>HD</u>	<u>NHD</u>
0.015 in.	66	81.8	0.0	6.1	1.5	9.1	1.5
0.005 in. or punctured	228	93.0	0.9	4.0	0.4	0.0	1.8

There is 99 percent assurance that the sample of fuzes with 0.005-in. thick or punctured diaphragms came from a population having a proper function score between 86 and 97 percent.

The T2061 function heights are reasonably consistent within all ground-launched rocket tests, there being no significant differences in heights due to fuze manufacturer or type rocket from a damage effectiveness viewpoint. The over-all average height for 137 proper functions over water is about 30 ft with a standard deviation of about 7 ft.

The results to date are insufficient to yield a reliable estimate of the radius of action of the T2061 fuze against the B17 target.

~~CONFIDENTIAL~~

~~SECRET~~

~~CONFIDENTIAL~~

The results of the limited train firing of rockets were satisfactory. Separate trains of 3, 7 and 11 rockets were released in 0.1-sec intervals with all rounds functioning properly.

5. FUTURE CONSIDERATIONS

Further evaluation and some modification of this fuze are still required:

- 1) Tests should be made to establish fuze performance at the required temperature extremes and in inclement weather.
- 2) A study should be made to determine the necessary change in circuitry to effect an improvement in burst positions against the smaller aircraft.
- 3) The A and C voltages should be optimized in terms of the fuze requirements (Report TR-186).

~~CONFIDENTIAL~~

Table 1. T2061 Field Tests.

Ground-Launched Rockets

Test	Report	Date	Arming	Diaphragm (in.)	Rocket	OE (deg)	N	P	I	E	M	HD	NHD	H (ft)	SP
<u>DOFL Fuzes Fired for Water-Approach Function</u>															
RX-T2061-1	23.5-34R	5/11/54	Raymond	0.015	ZUNI	15	8	8	0	0	0	0	0	26	100
-2	R23-55-17	2/16/55	GSC	0.015	ZUNI	15	24	17	0	3	0	3	1	38	71
-28	-17	2/24/55	GSC	0.015	HVAR	18	10	8	0	1	1	0	0	38	80
-6	-27	4/6/55	Hamilton	Punctured	HVAR	18	20	17	0	2	0	0	1	26	85
<u>Emerson Fuzes Fired for Water-Approach Function</u>															
RX-T2061-3	R23-55-18	3/3/55	GSC	0.015	HVAR	18	24	21	0	0	0	3	0	27	88
-5	-27	3/30/55	GSC	Punctured	HVAR	18	30	30	0	0	0	0	0	28	100
-6	-27	4/6/55	Hamilton	Punctured	HVAR	18	20	18	0	1	1	0	0	29	90
-7	-27	4/20/55	Hamilton	Punctured	HVAR	18	20	19	0	1	0	0	0	28	95
-7	-27	4/20/55	Hamilton	Punctured	ZUNI	12	17	16	0	1	0	0	0	33	94
<u>Emerson Fuzes Fired for Target Function</u>															
RX-T2061-4	R23-55-21	3/17/55	GSC	Punctured	HVAR	--	40	39	0	0	0	0	1	40*	98
-11	-36	5/11/55	Hamilton	0.005	HVAR	--	10	8	2**	0	0	0	0	30*	80

Air-Launched Rockets

Test	Report	Date	Arming	Diaphragm (in.)	Rocket	Release Speed (mph)	Alt (ft)	N	P	E	NHD	H (ft)	SP
<u>Emerson Fuzes Fired for Water-Approach Function</u>													
RX-T2061-8	R23-55-37	5/5,9/55	GSC	0.005	HVAR	300	2200	28	22	4	2***		79
-8	-37	5/18,24/55	Hamilton	0.005	HVAR	500	3500	22	22	0	0		100
-12	-38	5/23/55	Hamilton	0.005	HVAR	500	5000	21***	21	0	0		100

*Av Impact Parameter (Distance of function from target center in the plane perpendicular to target axis and containing the target center.)

**Impact functions with ground -- beyond target.

***Very wild flight on one dud round.

****Automatic (rapid fire, 1/10-sec interval) release in groups of 3, 7 and 11 rounds

N(Number) - Total number of rounds fired.

P(Proper Function) - Function near the expected height.

I(Impact Function) - Function on Impact.

E(Early Function) - Function before 10 sec.

M(Midfunction) - Function after 10 sec but appreciably higher than the expected height.

HD(Heard Dud) - No function but carrier received by monitoring station.

NHD(Not-heard Dud) - No function and no carrier received.

SECRET

CONFIDENTIAL

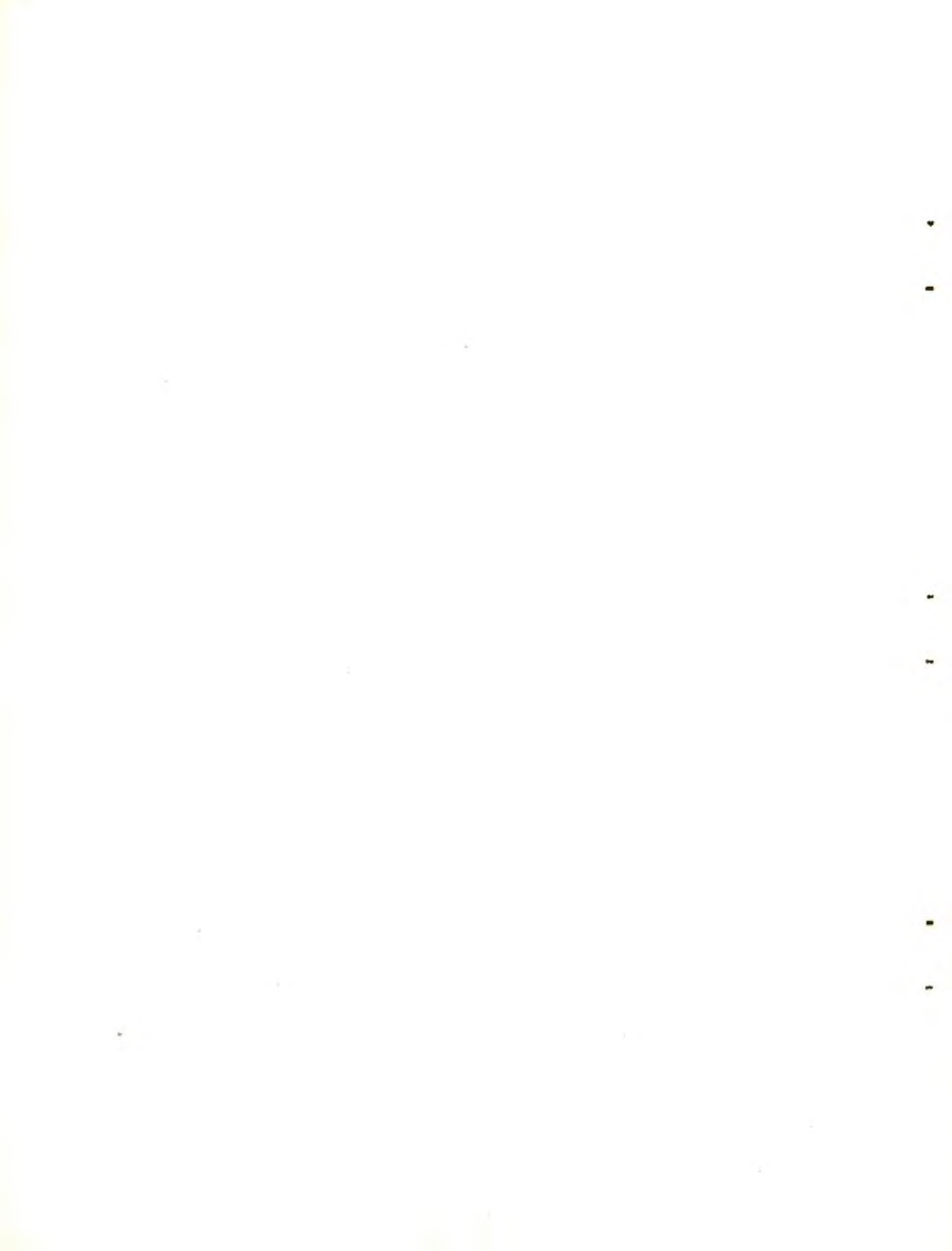

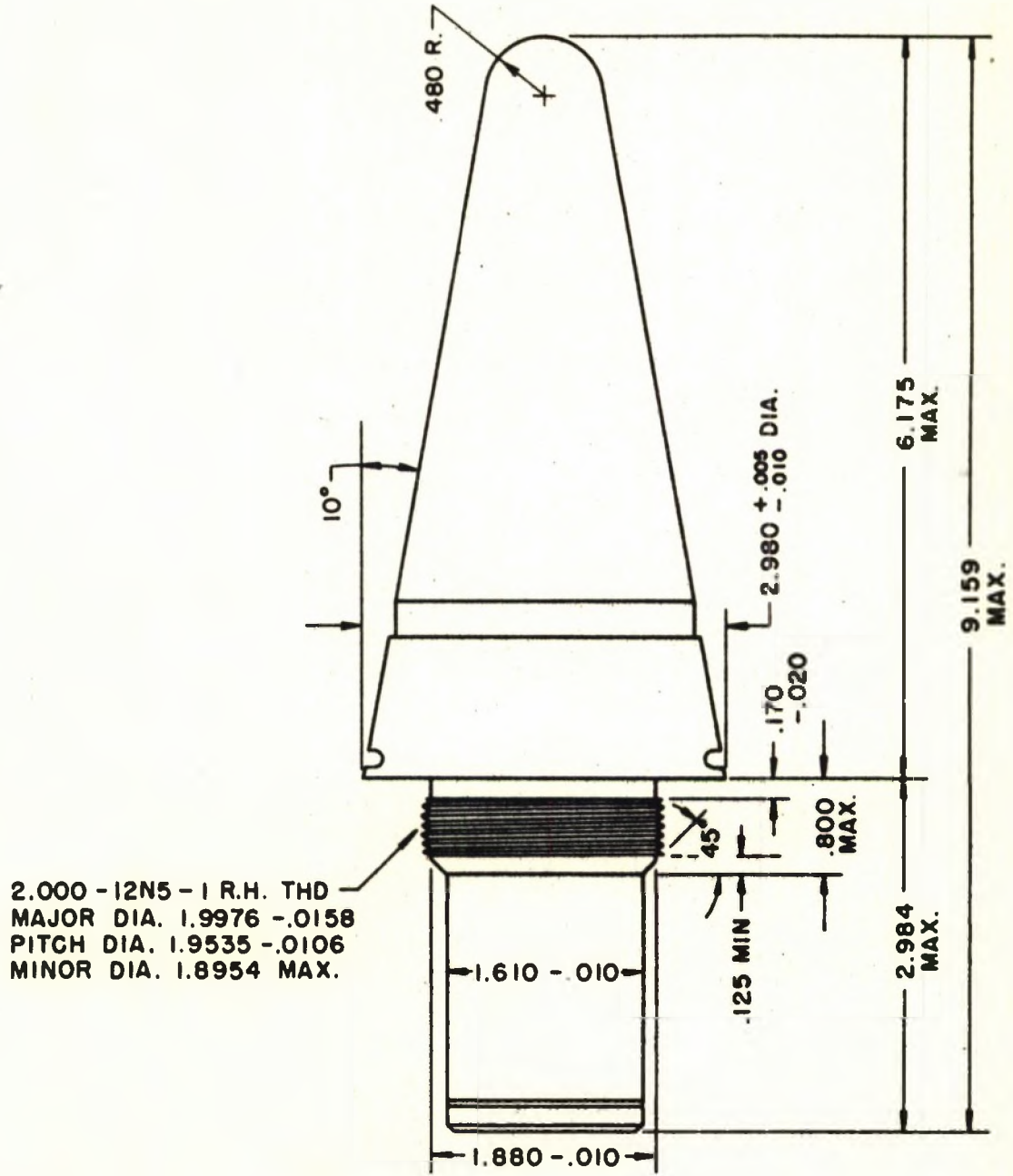

Figure 1. Fuze, VT, T2061 contour.

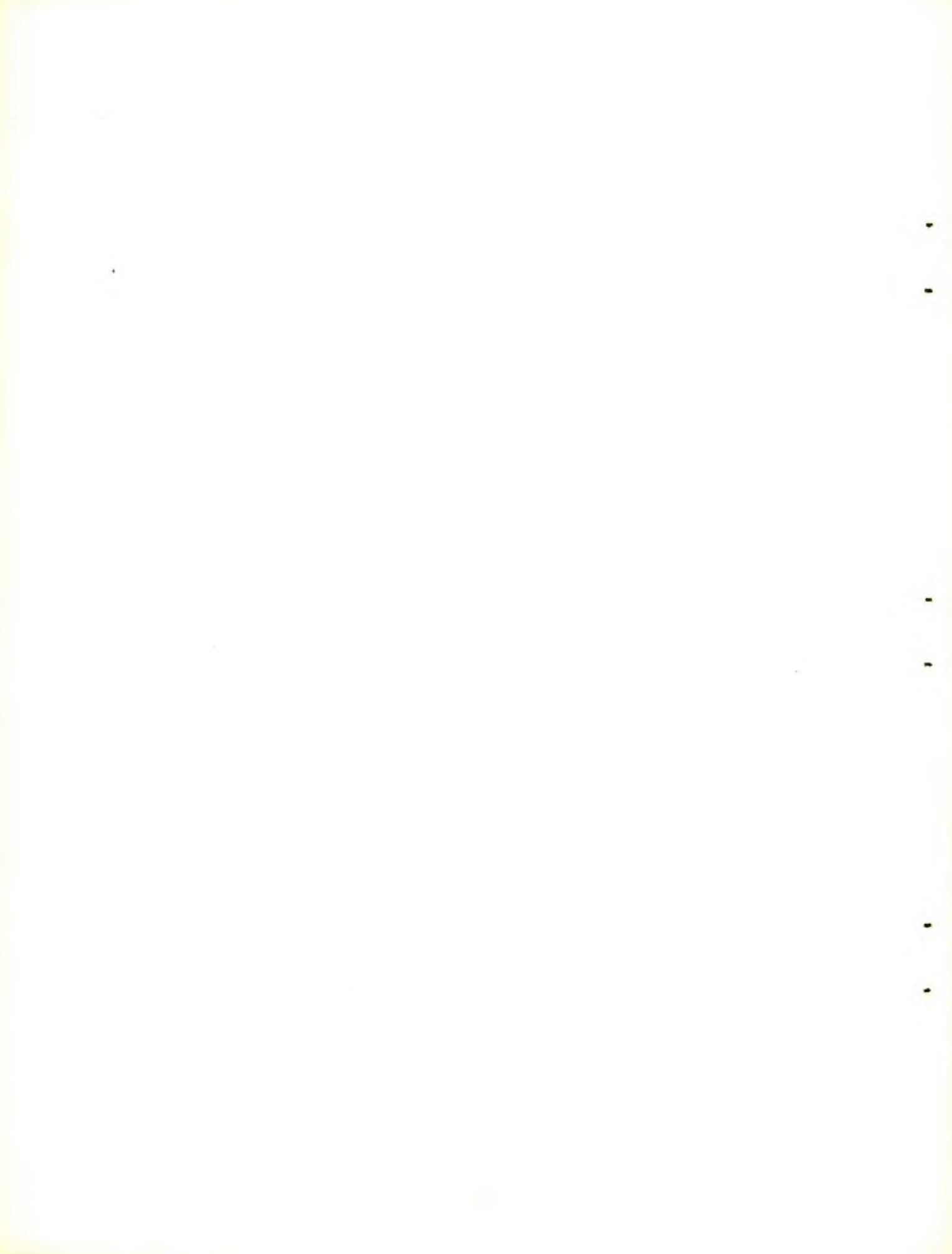



Figure 2. Fuze, VT, T2061, Mark 24 and 25 rocket heads for Zuni.

1000

CONFIDENTIAL

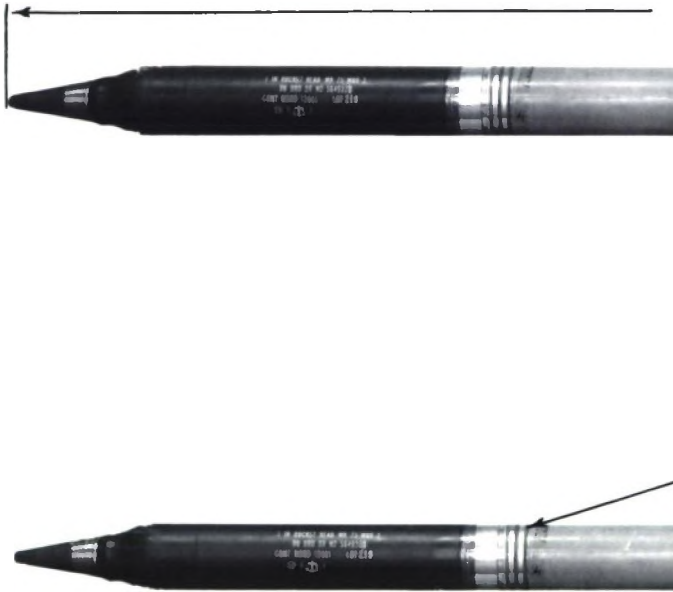
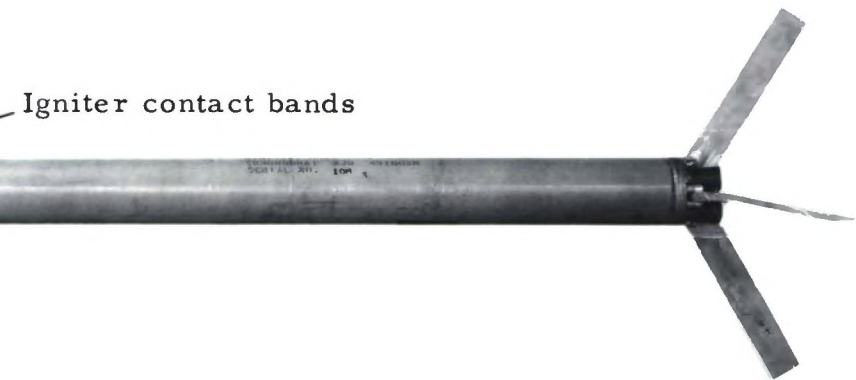

Figure 3. Fuze, V



CONFIDENTIAL

T, T2061, on Zuni, with Mk 25 head.

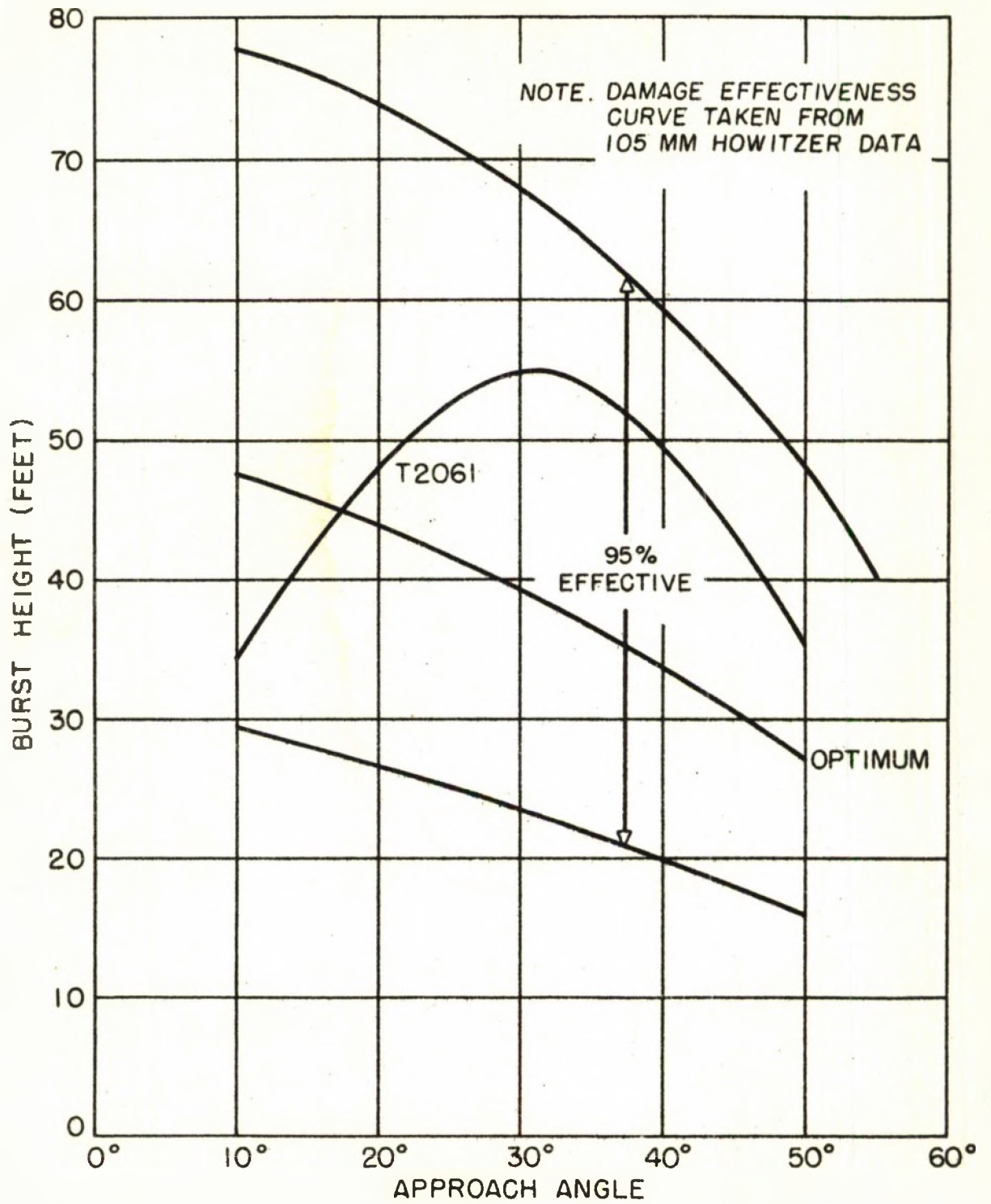

Figure 4. Fuze, VT, T2061 air-to-ground performance (N=.75)



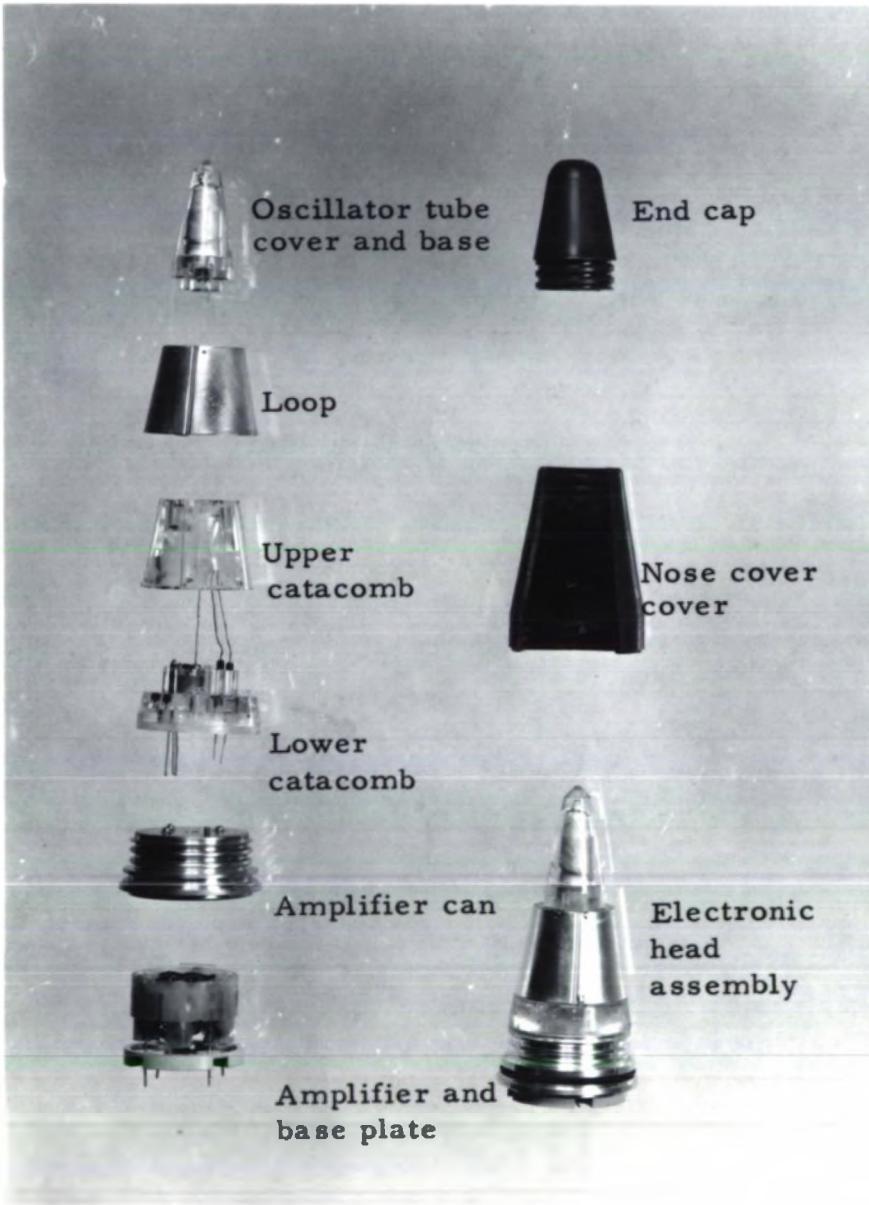

Figure 5 .Fuze, VT, T2061,

Complete
electronic
head
assembly

Sleeve

Battery
with
retainer
ring

Safety
and
arming
mechanism

Arming
chamber

Booster
cavity

End cup

Complete
fuze
assembly



COMBUSTION
No. 10

Layout of components.

2111

11111111

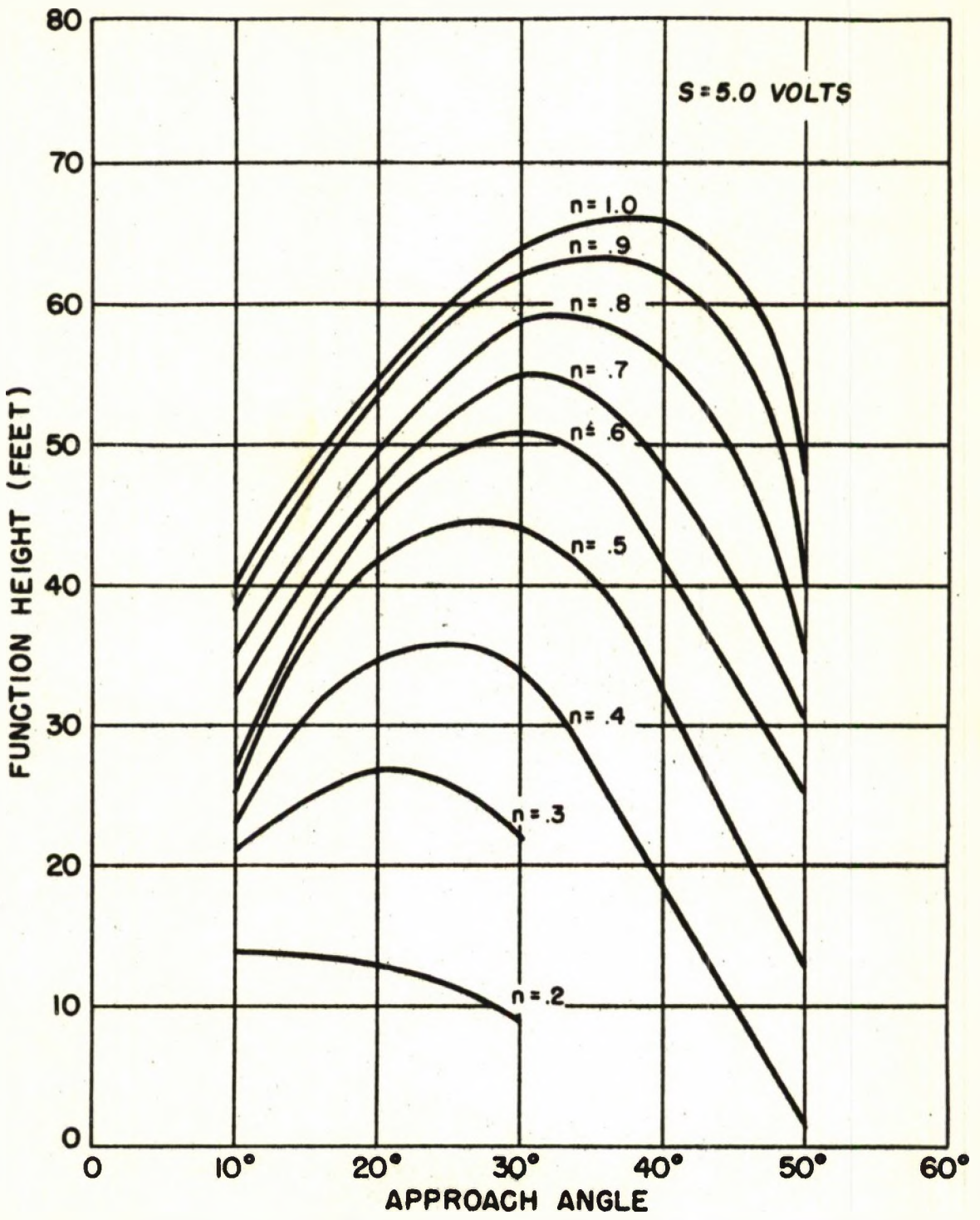

Figure 6 . Fuze, VT, T2061. Function height vs approach angle.

The first part of the document
 discusses the general principles
 of the proposed system.
 It is intended to provide a
 clear and concise overview
 of the key concepts and
 objectives of the project.
 The following sections will
 describe the detailed
 implementation and the
 expected outcomes.

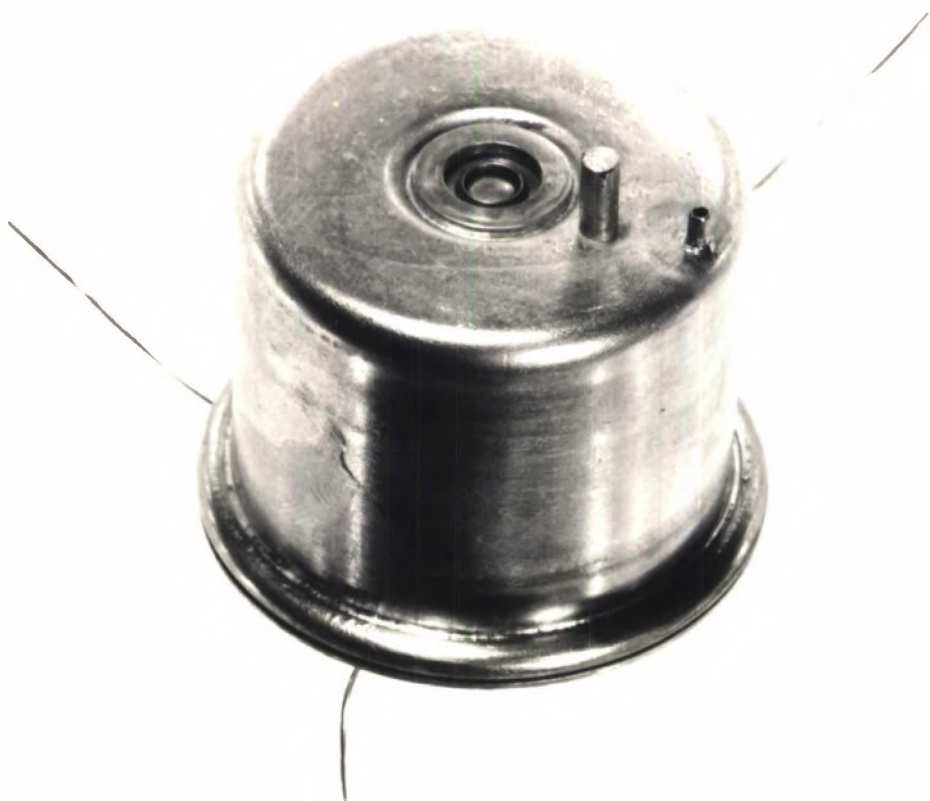
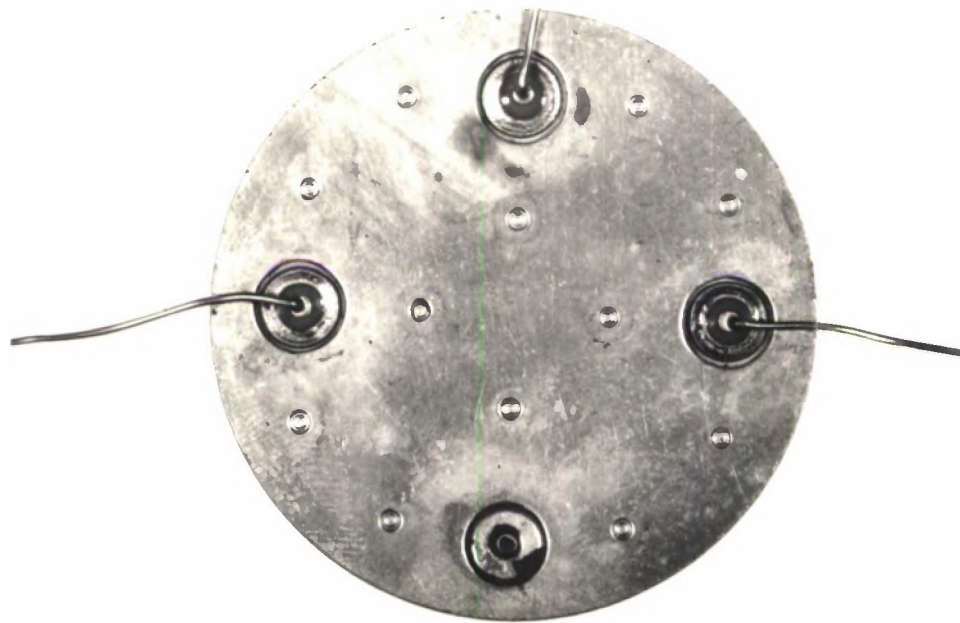

Figure 7. T2061 Power supply.

Handwritten notes in a box, including a date and a name.

11/11/11

11/11/11

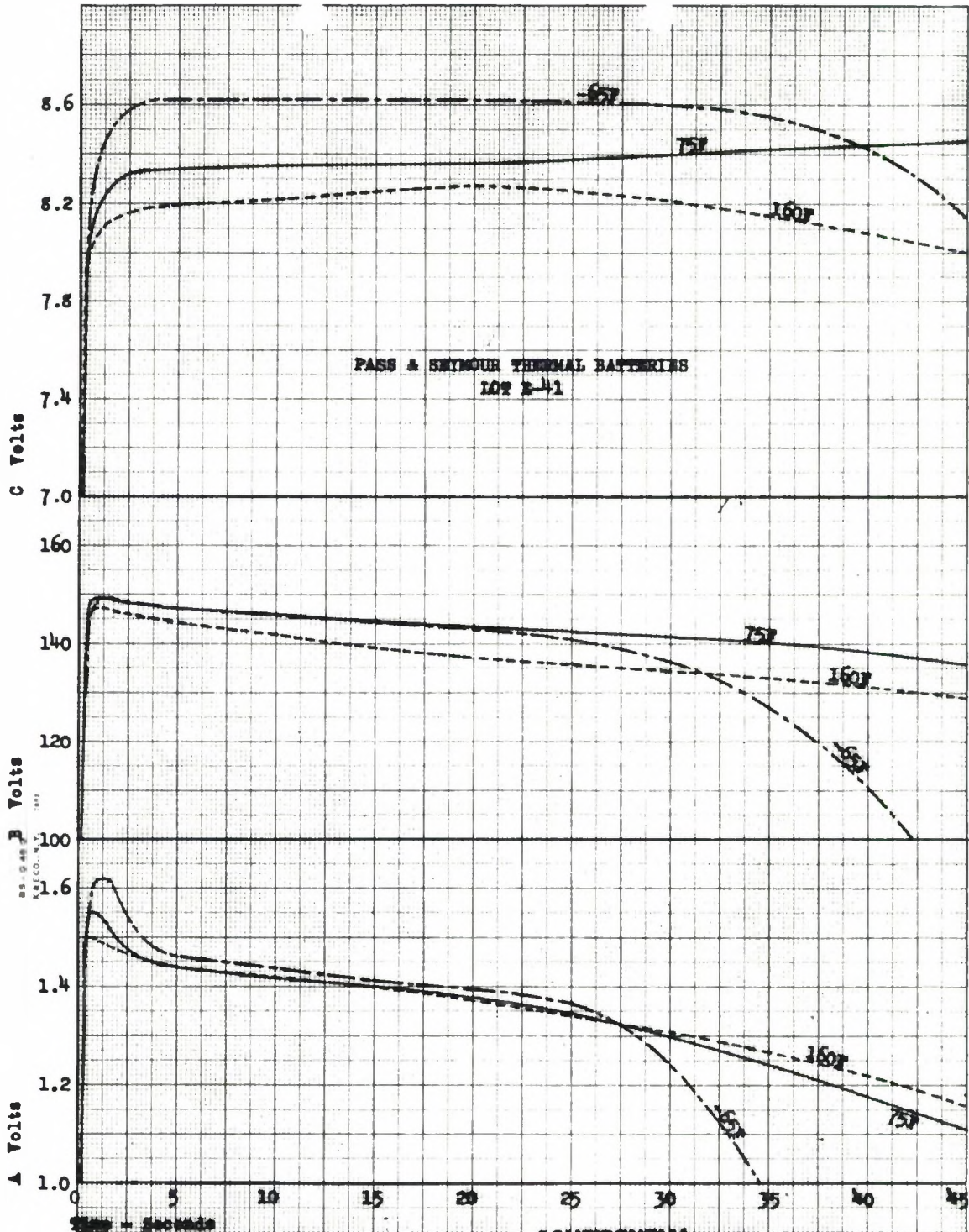

Figure 8. Average voltage curves, T2061 batteries.

03-270

03-270

~~03-270~~

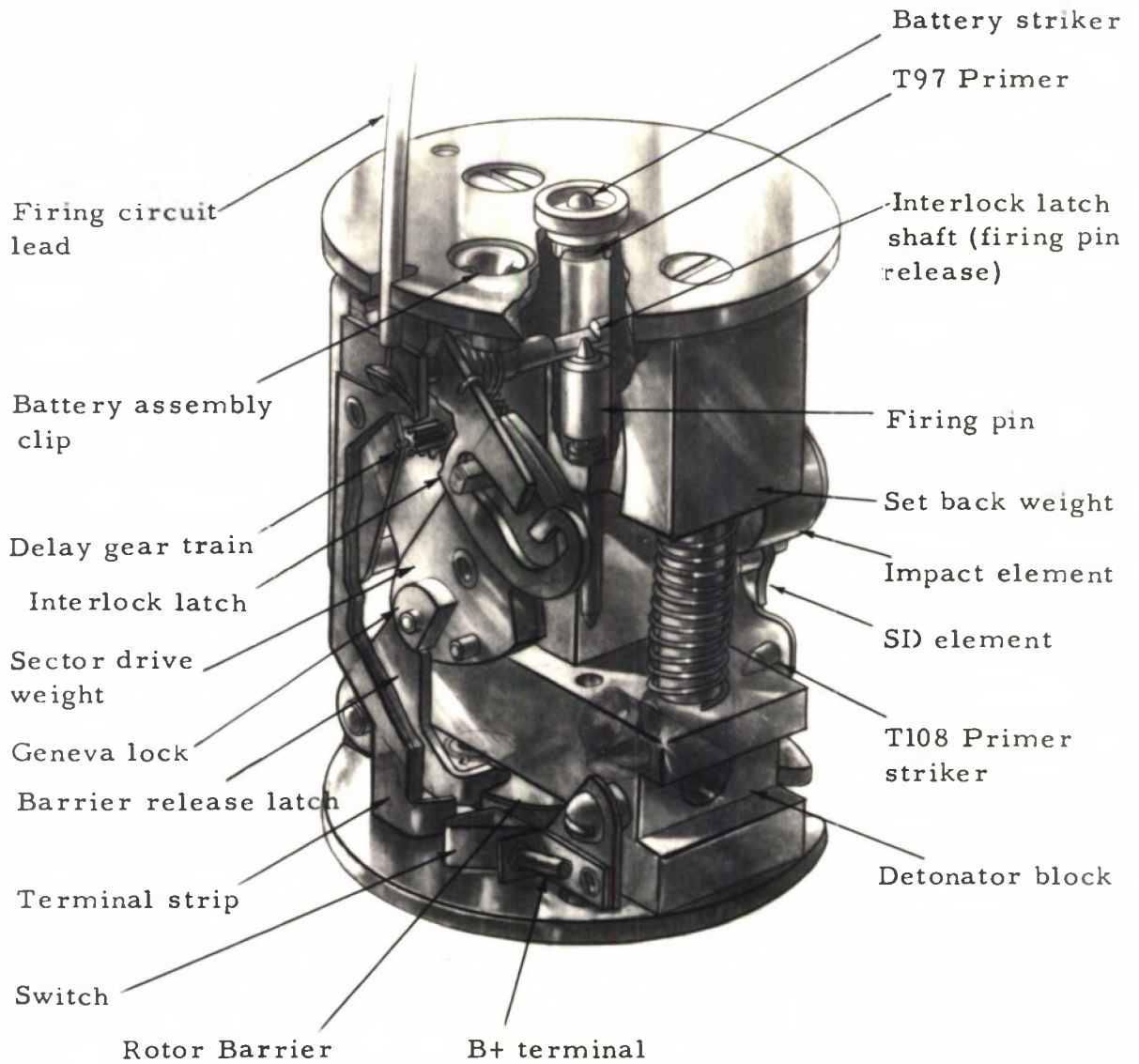

Figure 9. T2061 Safety and arming mechanism.

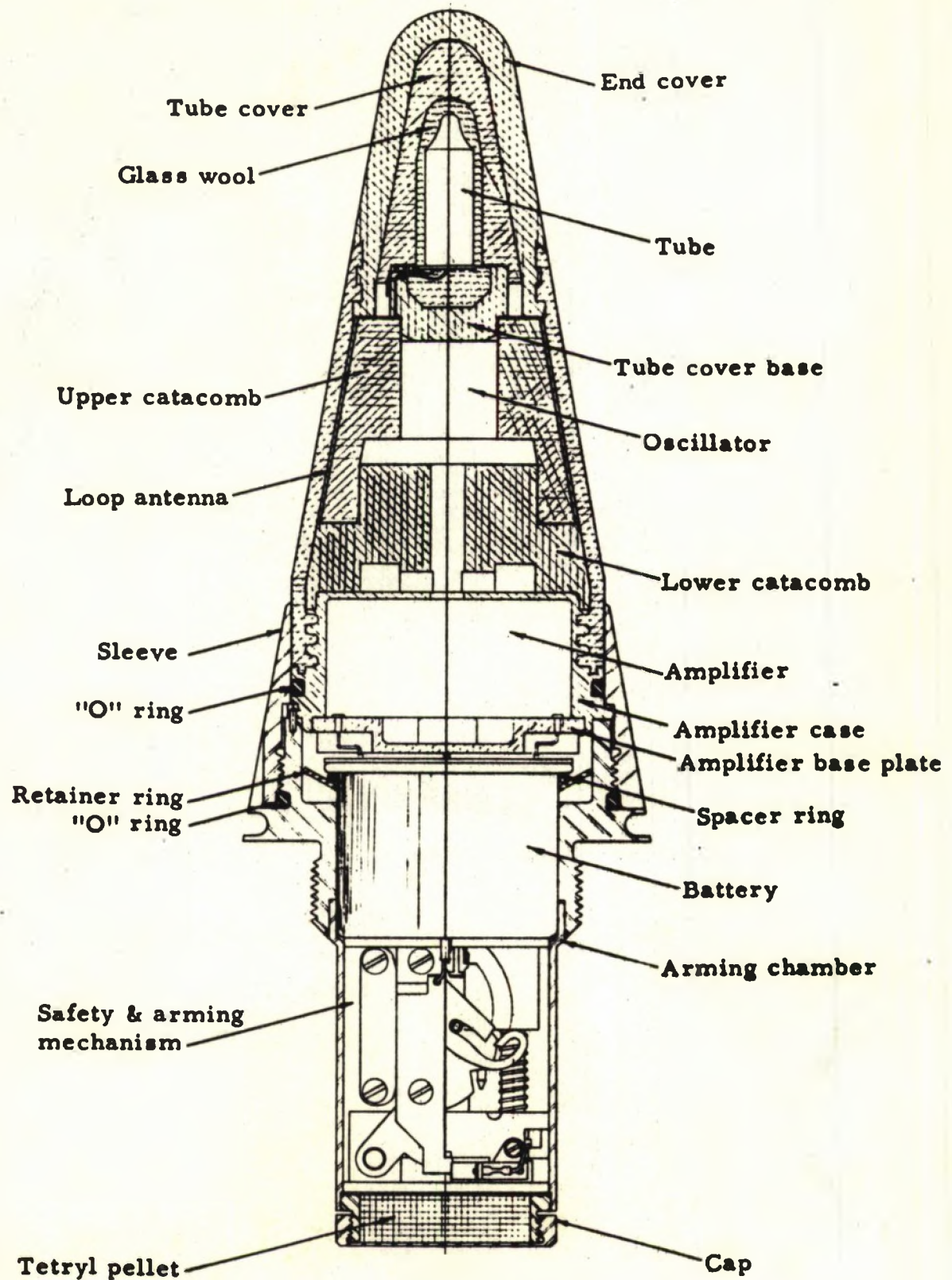
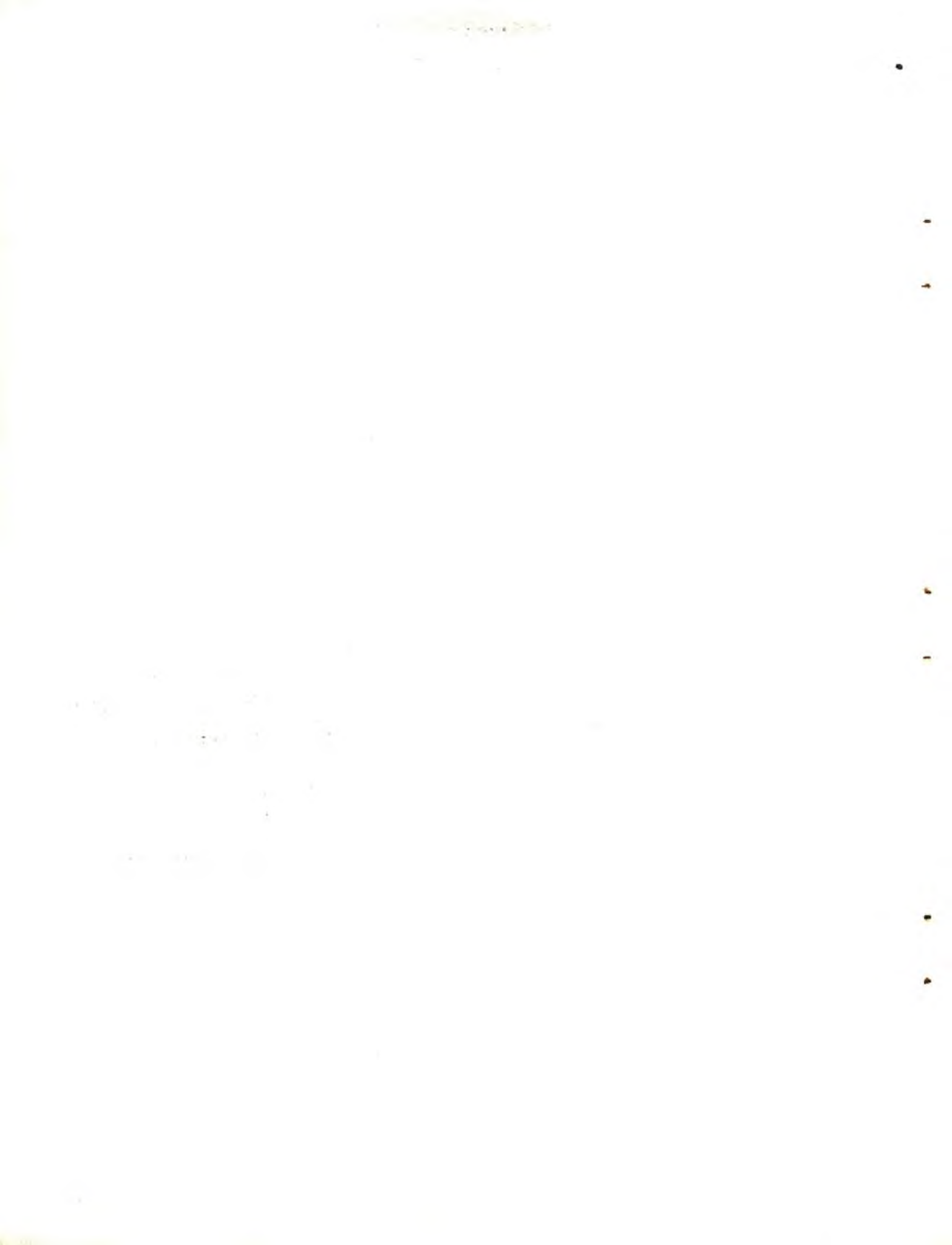

Figure 10. Fuze, VT, T2061, cross section.



~~CONFIDENTIAL~~

~~SECRET~~

BIBLIOGRAPHY

DOFL Reports:

- TR-96 Fuze, VT, T2031E1, Design Release, (including complete Bibliography, p. 57-65) 30 June 1954 - J. W. Fraumann
- TR-186 Fuze, VT, T2061, Battery (Design Release) 1 July 1955 - J. Hoke and G. L. Scillian
- TR-187 Fuze, VT, T2061, Safety and Arming Mechanism (Design Release) 1 July 1955 - Roland A. Ebner
- R22-55-9 Structural Components of the T2061 Fuze, Roland A. Ebner
- R21-55-9 Operation of the T2061 Rocket Fuze with FLAF7 Amplifier in Simulated Tail-On Approach to a Russian MIG-15 Fighter, 14 February 1955 - W. L. Gieseler
- R21-55-11 Operation of the T2061/FLAF7 Rocket Fuze in Simulated Tail-On Approach to a B29 Bomber, 16 March 1955 - W. L. Gieseler
- R21-55-22 Tentative Specifications for Fuze, VT, T2061, M. F. Oertel

Airborne Instruments Laboratory Reports:

- T/M2016 Technical Memoranda - File 2016 CM Susceptibility Test on the T2031E1 Fuze (Preliminary Data), 10 June 1954 - M. Natchipolsky
- 2016-T-21 Test Report on the Susceptibility to CM of the T2031E1 Fuze , May 1955 - M. Natchipolsky and A. M. Levine

~~CONFIDENTIAL~~

~~SECRET~~

Emerson Radio and Phonograph Corporation Reports:

- Special Report No. 3 Tolerance Study of FLAF-7 Amplifier,
3 January 1955 - M. S. Berkoff
- Special Report No. 4 Test Procedures of T2061, 29 June 1955 -
M. S. Berkoff

~~CONFIDENTIAL~~
~~SECRET~~

APPENDIX A
T2061 CIRCUIT DIAGRAM
AND
SUPPLEMENTARY DATA ON PERFORMANCE

~~CONFIDENTIAL~~

~~SECRET~~

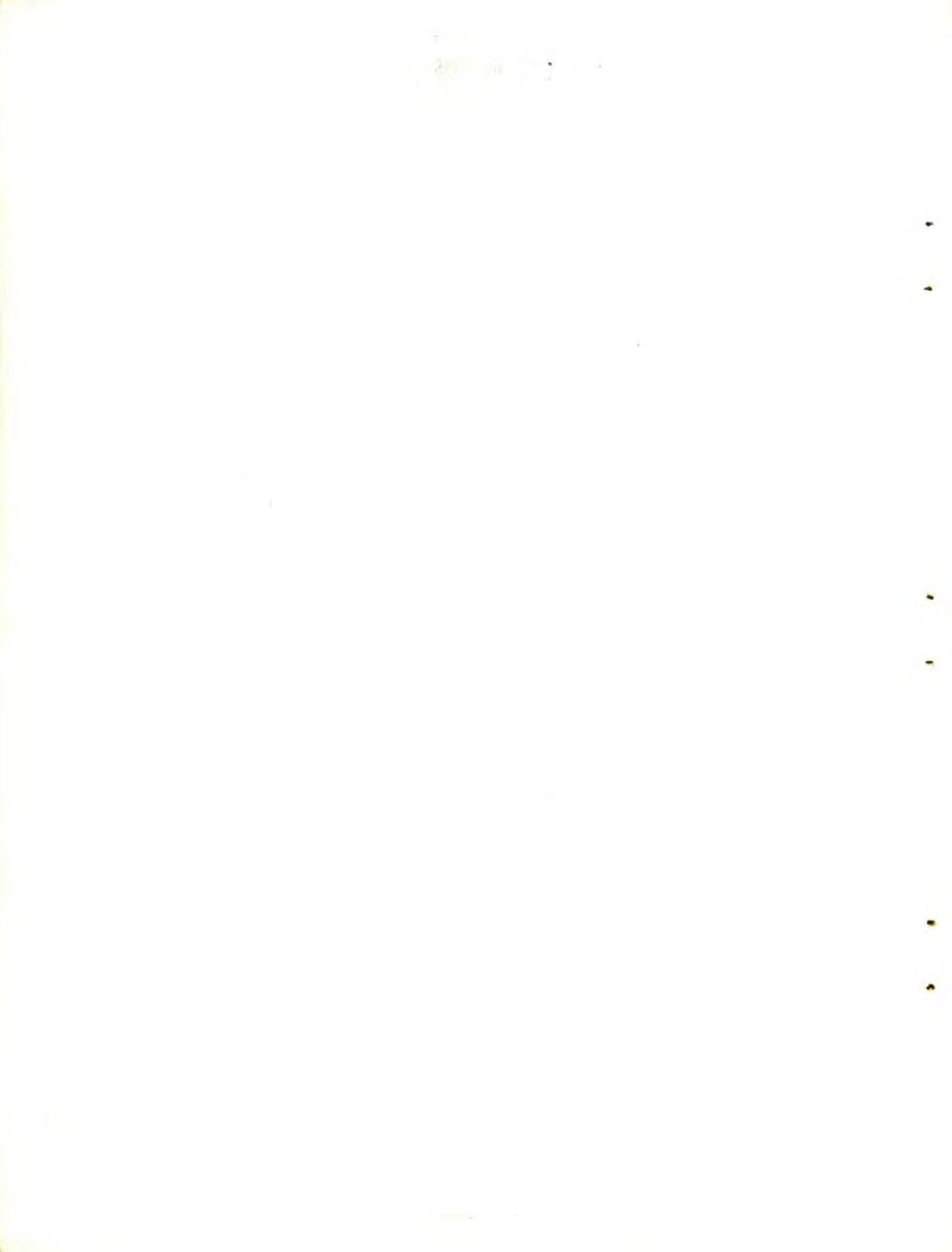

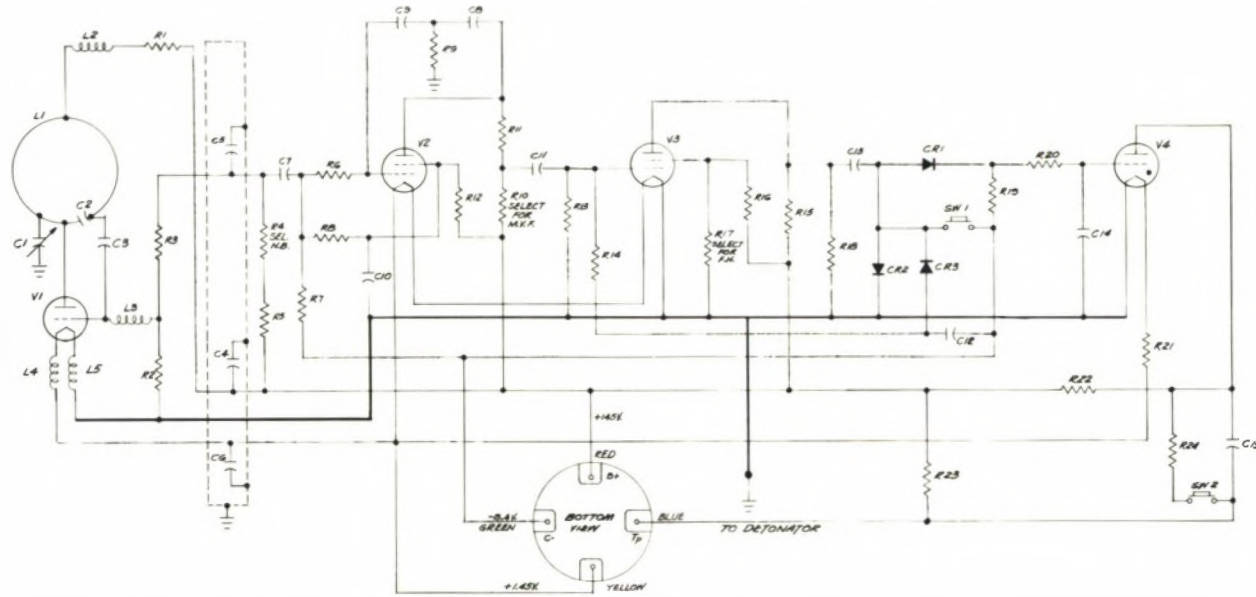

PART	DESCRIPTION	REFERENCE
R1	1 h ± 5%	B-300, 231-1
R2	47 h ± 5%	B-300, 231-2
R3	150 h ± 5%	B-300, 231-3
R4	0 - 200 h Select For Noise Supp.	B-300, 233-1
R5	200 h ± 10%	B-300, 233-2
R6	1.0 meg. ± 10%	B-300, 233-3
R7	5.3 meg. ± 10%	B-300, 233-4
R8	10.4 meg. ± 10%	B-300, 233-5
R9	150 h ± 10%	B-300, 233-6
R10	330 h - 750 h Select For cond.	B-300, 233-7
R11	0.20 h ± 10%	B-300, 233-8
R12	30.0 meg. ± 10%	B-300, 233-9
R13	5.3 meg. ± 5%	B-300, 233-10
R14	10.0 meg. ± 5%	B-300, 233-11
R15	2.20 h ± 10%	B-300, 233-12
R16	0.2 h ± 10%	B-300, 233-13
R17	13 h - 27 h Select For L.h.	B-300, 233-14
R18	420 h ± 10%	B-300, 233-15
R19	7.5 meg. ± 5%	B-300, 233-16
R20	300 h ± 5%	B-300, 233-17
R21	1.0 ohm ± 10%	A-300, 431-1
R22	2.2 meg. ± 10%	B-300, 233-18
R23	1.0 meg. ± 10%	B-300, 233-19
R24	4.7 h ± 20%	B-300, 233-20

PART	DESCRIPTION	REFERENCE
C1	Mechanical Adj. For Loop Balance	A-300, 431
C2	Part of L1	C-300, 441
C3	2.2 mfd. ± 10% 300 v.	A-300, 444-1
C4	300 mfd. ± 20%	B-300, 170
C5	300 mfd. ± 20%	B-300, 170
C6	300 mfd. ± 20%	B-300, 170
C7	.0027 mfd. ± 10% 100 v.	B-300, 233-2
C8	47 mfd. ± 10% 300 v.	A-300, 444-3
C9	27 mfd. ± 10% 300 v.	A-300, 444-2
C10	0.047 mfd. ± 10% 100 v.	B-300, 233-2
C11	0.027 mfd. ± 10% 200 v.	B-300, 233-4
C12	.015 mfd. ± 10% 200 v.	B-300, 232-1
C13	.0027 mfd. ± 10% 200 v.	B-300, 233-4
C14	.022 mfd. ± 5% 100 v.	B-300, 233-5
C15	01 mfd. ± 20% 200 v.	B-300, 232-2

PART	DESCRIPTION	REFERENCE
V1	6X4	A-300, 431
V2	6BM51A	A-300, 237
V3	6BM51A	A-300, 237
V4	6BM52A	A-300, 432
CR1	DIODE	A-300, 171
CR2	DIODE	A-300, 171
CR3	DIODE	A-300, 171
L1	LOOP	C-300, 441
L2	1 oh	B-300, 232
L3	1 oh	B-300, 232
L4	1 oh	B-300, 232
L5	1 oh	B-300, 232
SW1	BALL SWITCH	B-300, 491
SW2	BALL SWITCH	B-300, 493

Figure A1. Fuze, VT, T2061, circuit diagram.

039270

1111

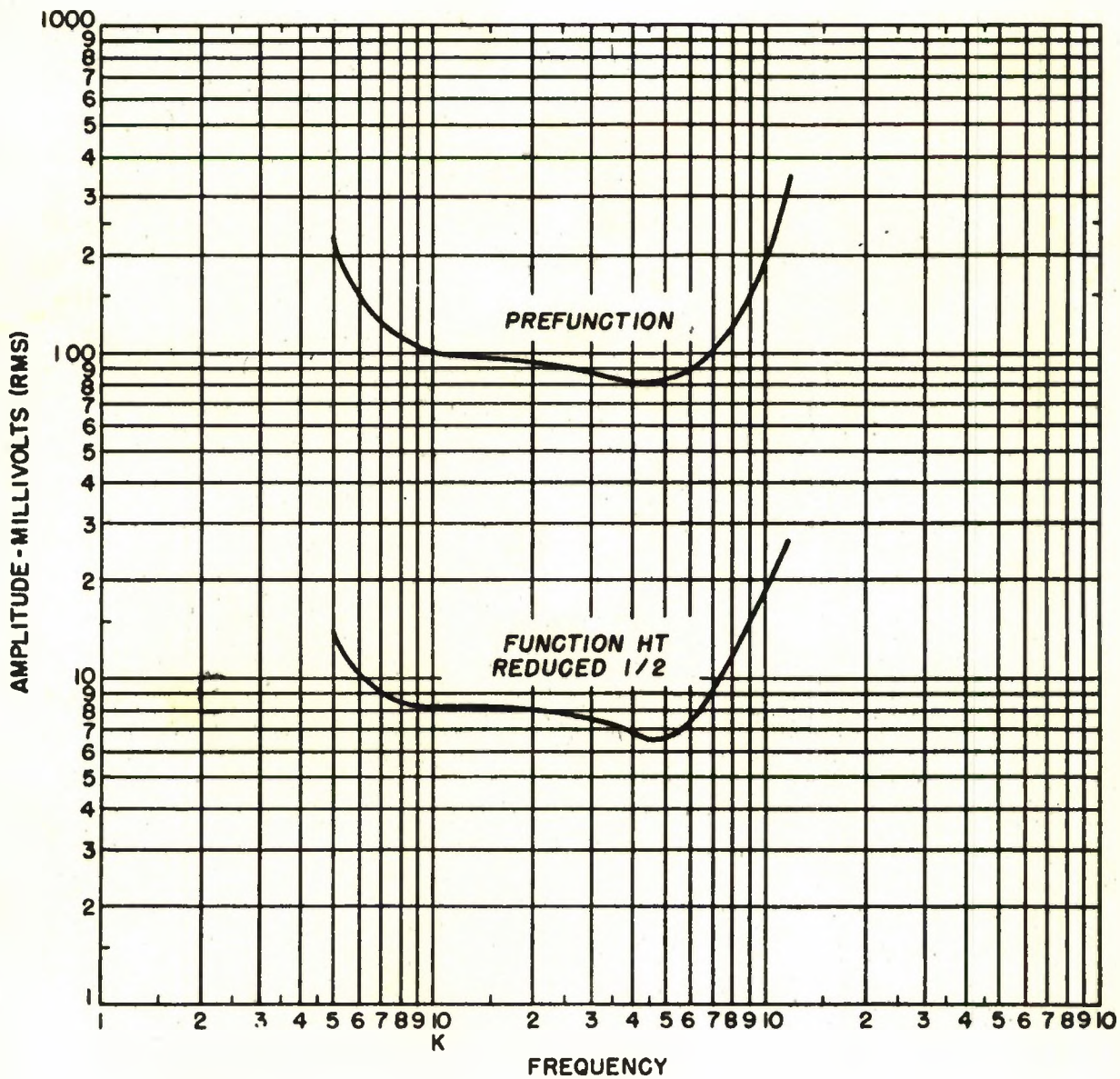

Figure A2. Fuze, VT, T2061, effect of steady state sine wave interference upon function height for 30° air-to-ground approach.



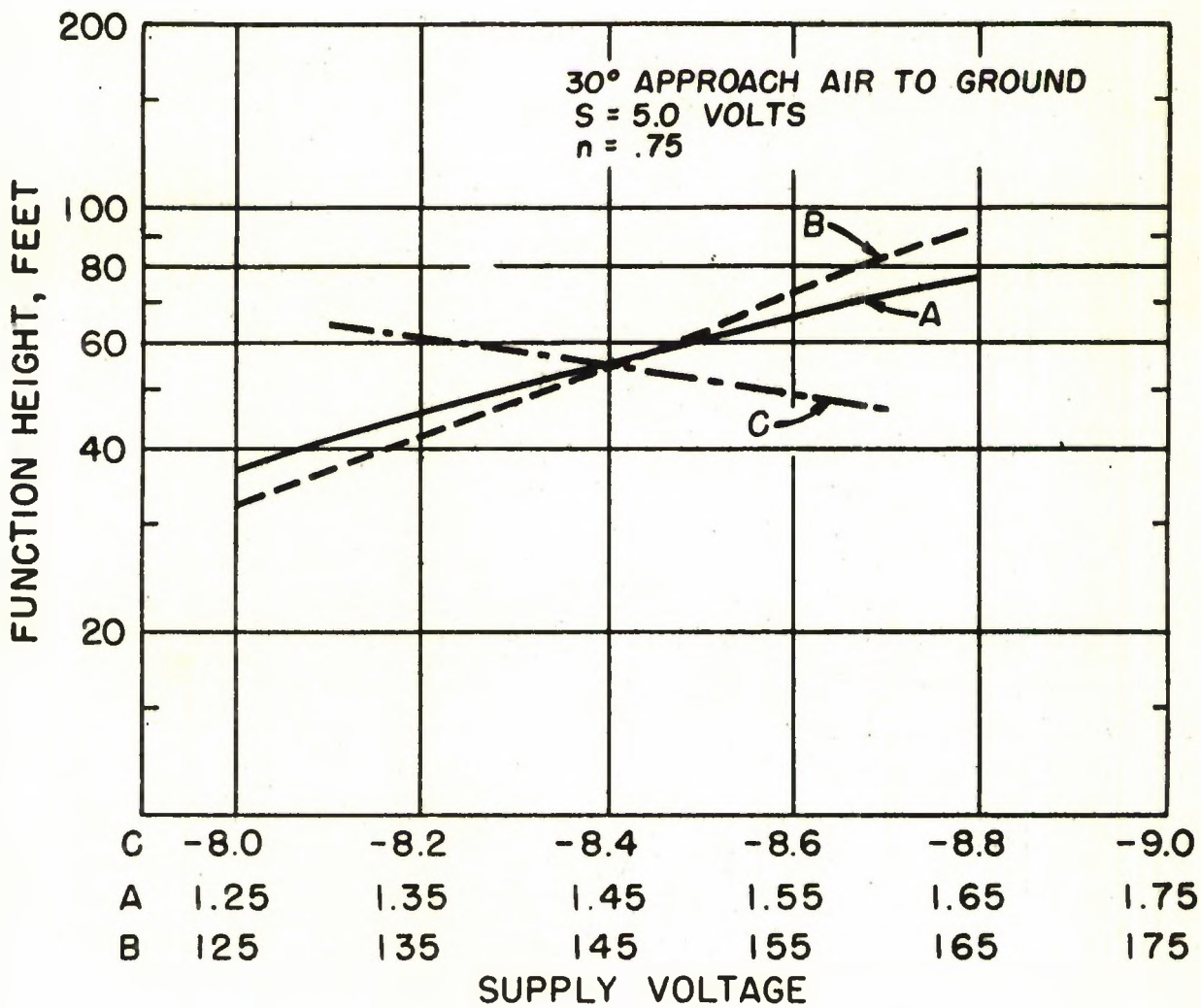

Figure A3. T2061 Amplifier, effect of supply voltage variation upon height.



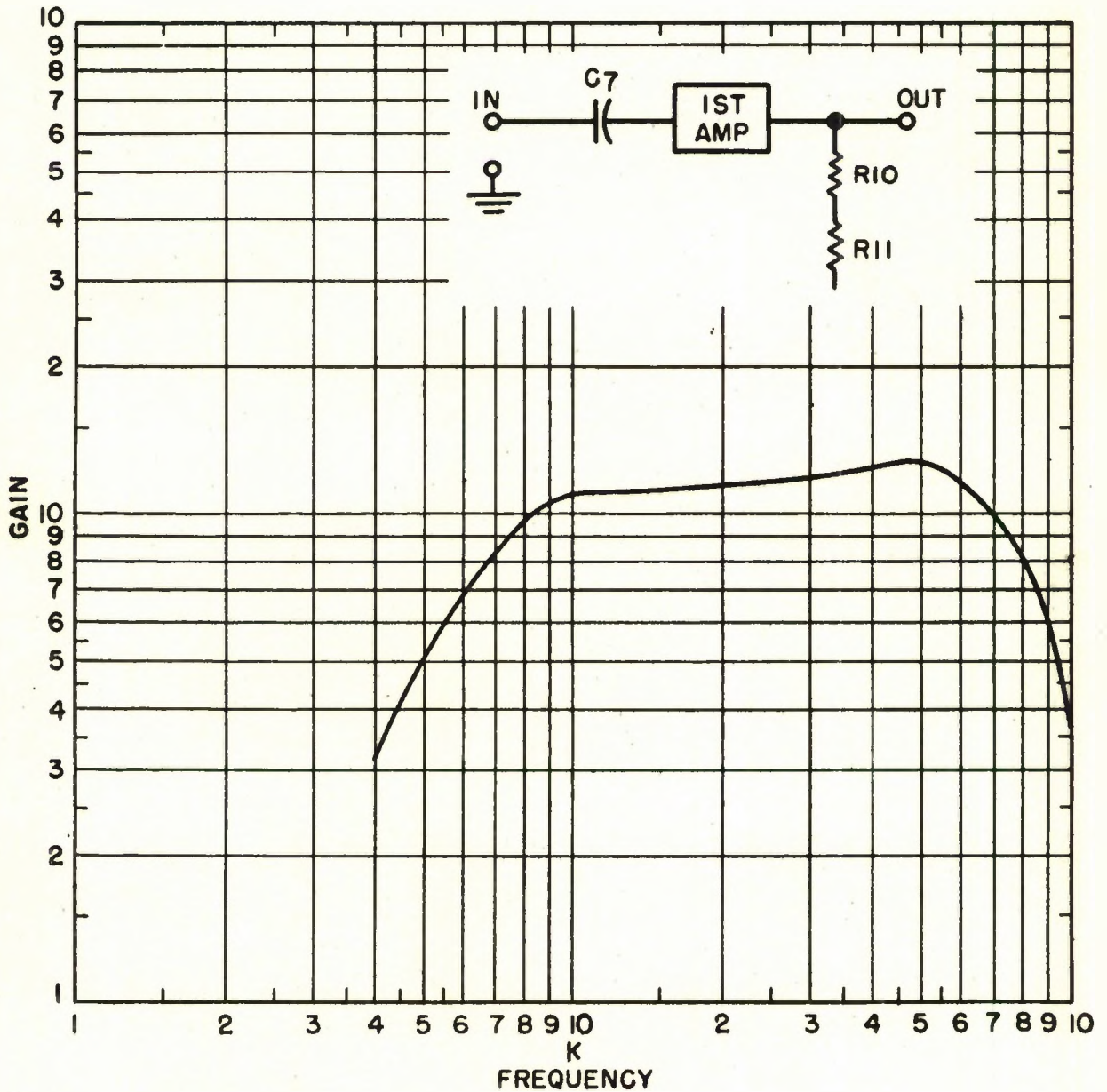
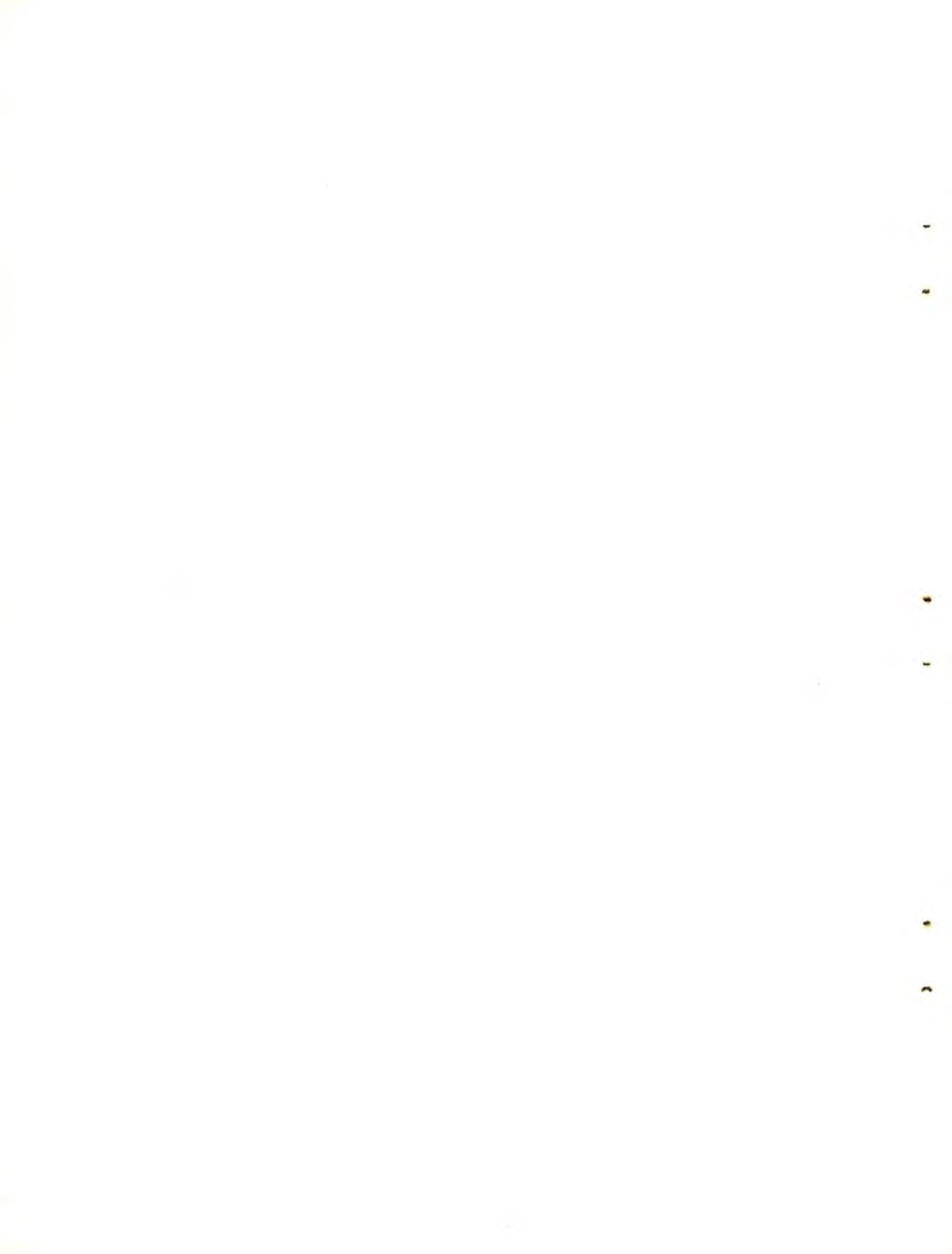

Figure A4. T2061 Amplifier, typical frequency response of first stage.



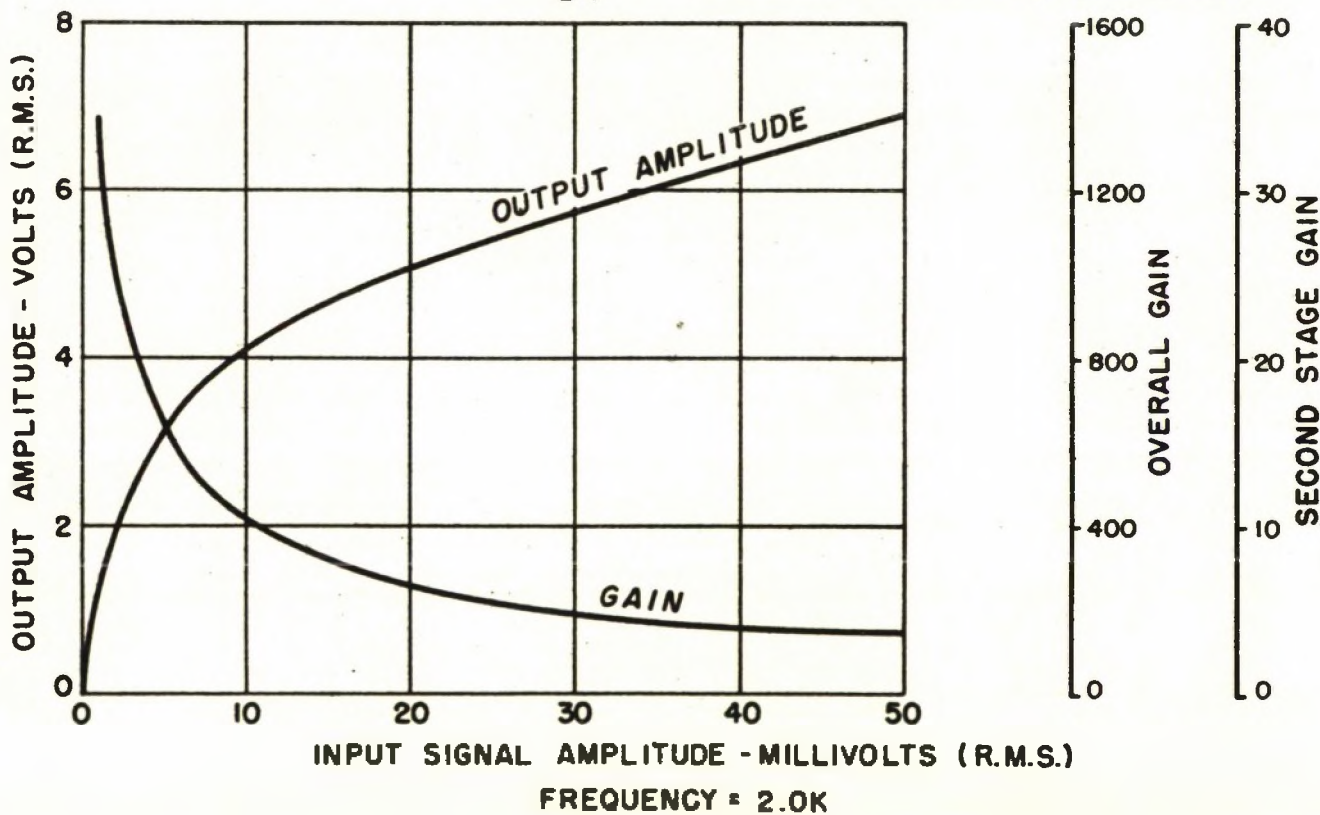
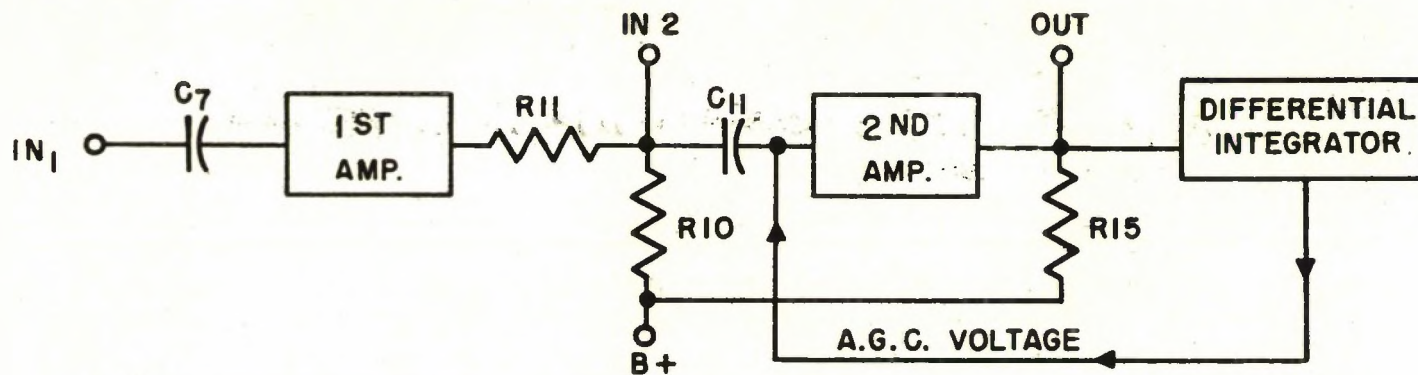

Figure A5. T2061 Amplifier over-all gain and output voltage vs input signal.



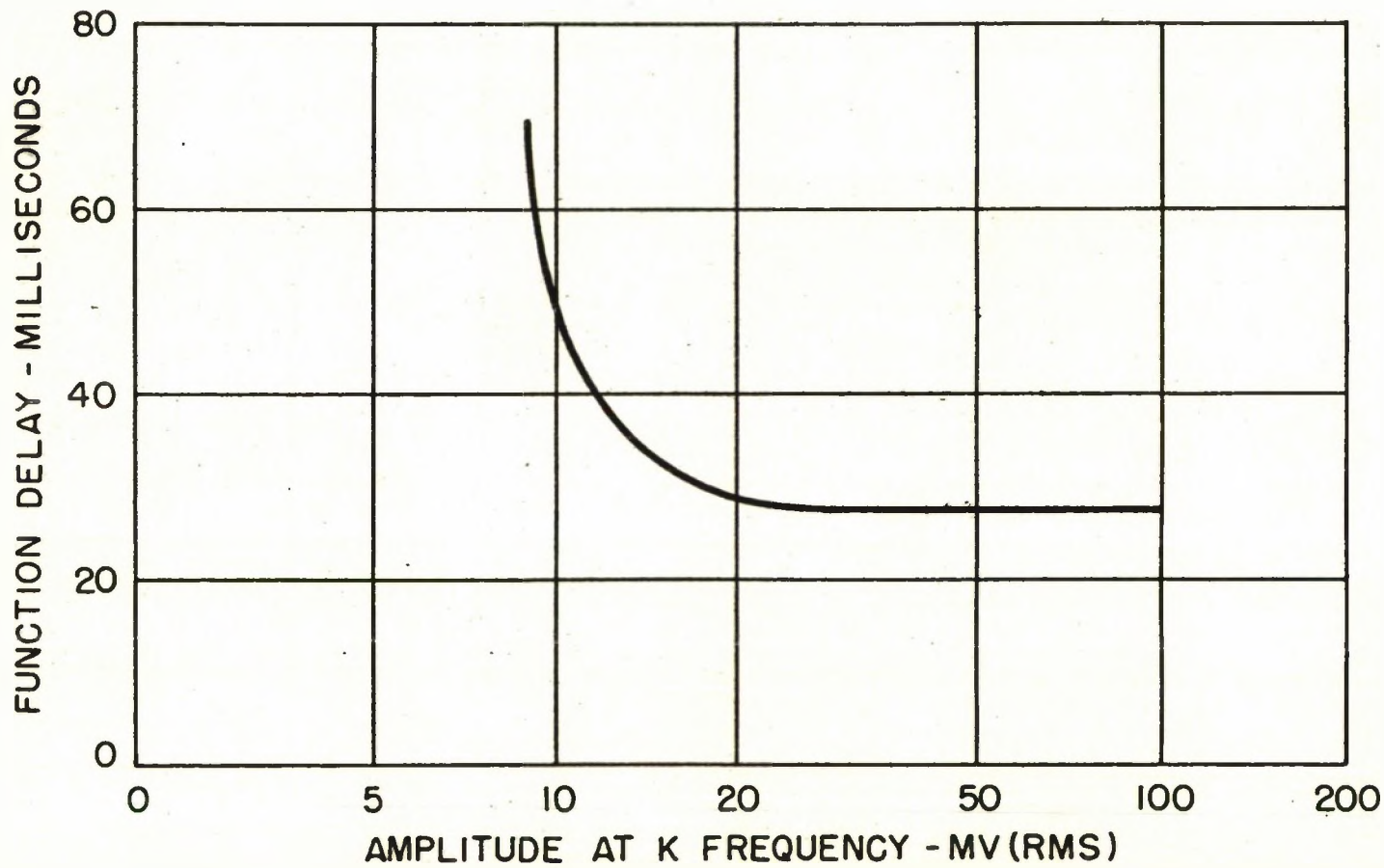

Figure A6. T2061 Amplifier, function delay vs amplitude for sine-wave bursts.



~~SECRET~~

~~CONFIDENTIAL~~

APPENDIX B

EMERSON TEST MANUALS

Amplifier Tube Tester	EG812
Thyratron Tube Tester	EG822
Diode Tester	EG787
Tube Microphonics Tester	EG254
Resistor Noise Tester	EG794
N67 Self-Noise Tester	EG986
Amplifier Test Position	EG1345
Final Test Position	EG1349
Oscillator Test Position	EG1342

~~CONFIDENTIAL~~



~~SECRET~~

~~CONFIDENTIAL~~

APPENDIX C
LIST OF DRAWINGS AND PARTS
OF
FUZE, VT, T2061

~~CONFIDENTIAL~~

~~SECRET~~







~~SECRET~~
~~CONFIDENTIAL~~

~~CONFIDENTIAL~~
~~SECRET~~

DIAMOND ORDNANCE FUZE LABORATORY
PROJECTILE FUZE LABORATORY

L. D. No. B-300482
SHEET 2 OF 2 SHEETS

LIST OF DRAWINGS, PARTS AND SPECIFICATIONS

ORIGINAL DATE:
30 JUNE 1955

FOR: OSCILLATOR - AMPLIFIER ASSEMBLY

DRAFTSMAN	CHECKER	REVISIONS	NO.	SHEET	DATE
PROJ. ENGR.	PROJ. ENGR.				
SUBMITTED BY	CHIEF SEC.				
EXAMINED BY	CHIEF ENGR.				
APPROVED BY	CHIEF DIV.				

LINE NO.	DRAWING NUMBER	N O M E N C L A T U R E	NUMBER REQUIRED		REMARKS
			PER ASSY.	TOTAL	
1	B-300.131	SHOCK MOUNT TUBE ASSY		1	
2	A-300.135	BALANCE ADJUSTMENT SCREW		1	
3	B-300.136	TUBE COVER		1	
4	A-300.137	TUBE NUT		1	
5	C-300.138	TUBE COVER BASE		1	
6	B-300.139	UPPER & LOWER CATACOMB ASSY		1	
7	B-300.140	UPPER CATACOMB ASSY		1	
8	C-300.141	LOOP		1	
9	C-300.142	LOOP RING		1	
10	C-300.143	UPPER CATACOMB		1	
11	A-300.144-1	CAPACITOR SPECIFICATIONS		1	
12	A-300.144-2	CAPACITOR SPECIFICATIONS		1	
13	A-300.144-3	CAPACITOR SPECIFICATIONS		1	
14	B-300.145	LOWER CATACOMB ASSY		1	
15	A-300.146	BALANCE TAB, FORMING DETAIL		1	
16	A-300.147	BALANCE TAB, DEVELOPMENT		1	
17	B-300.148	LOWER CATACOMB		1	
18	B-300.149	AMPLIFIER CASE ASSY		1	
19	C-300.150	AMPLIFIER CASE		1	
20	A-300.151	RESISTOR SPECIFICATIONS		1	
21	A-300.152	TUBE ENG92-A		1	
22	A-300.161	DETONATOR LEAD		1	
23	A-504.271	SELENIUM RECTIFIER		1	
24	A-504.257	TUBE ENG91-A		2	
25	B-600.064	SPECIAL MOLD BASE		1	
26	B-600.072	POTTING MOLD, ELECT. HEAD		1	
27	B-300.193	BALL SWITCH LIST OF INGS.		2	
28	B-300.684	R.F. CHOKE SPECIAL TEST FIXTURE		-	FOR B-300.952
29					
30					
31					
32					
33					
34					
35					
36					
37					

NOTES:

~~CONFIDENTIAL~~

~~SECRET~~



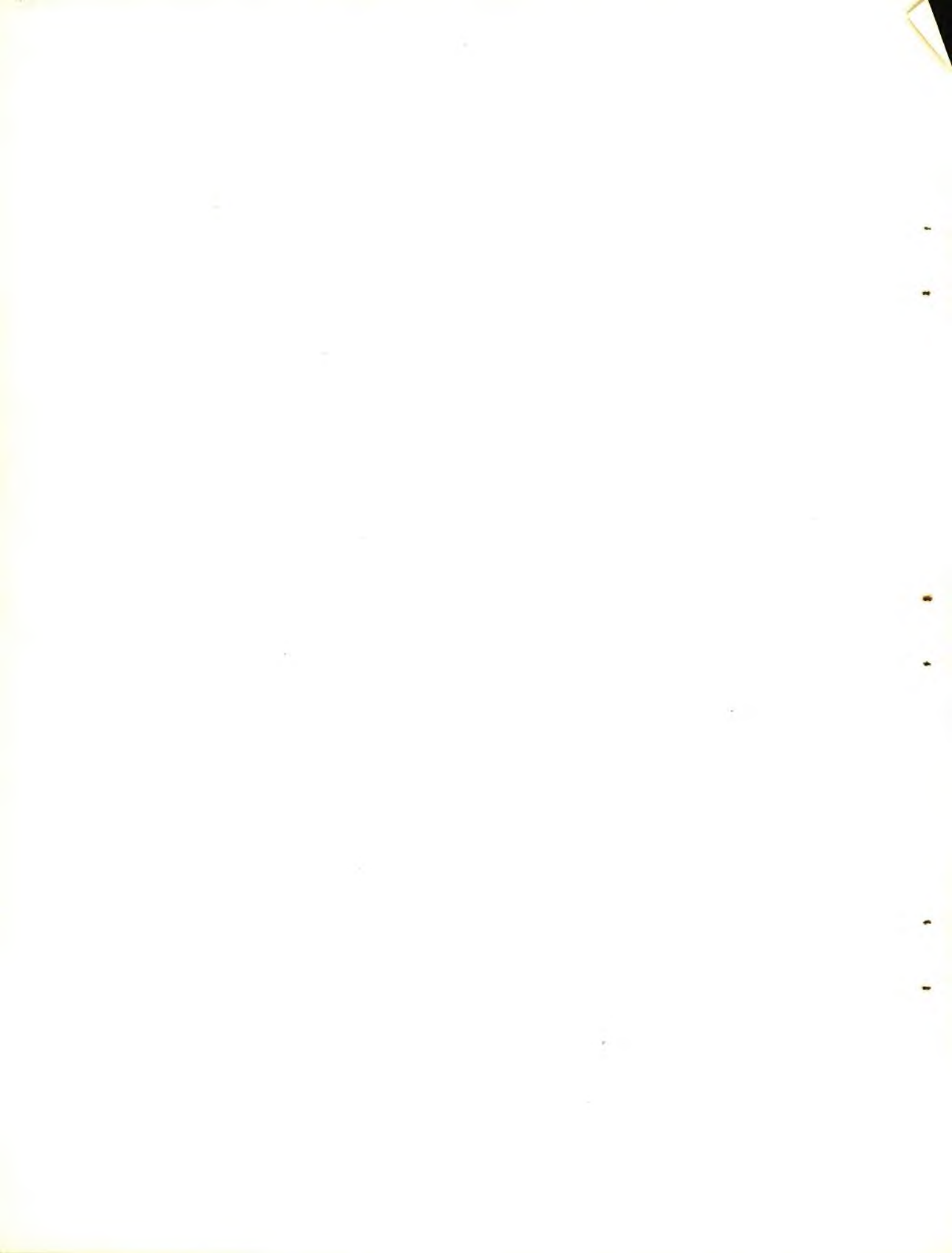

CONFIDENTIAL <small>SECURITY INFORMATION</small>		DIAMOND ORDNANCE FUZE LABORATORY PROJECTILE FUZE LABORATORY		L. D. No. B-300483 SHEET 2 OF 2 SHEETS		
LIST OF DRAWINGS, PARTS AND SPECIFICATIONS				ORIGINAL DATE: 30 June 1955		
FOR: T-2061 POWER SUPPLY, PMS MODEL 62						
DRAFTSMAN	CHECKER	REVISIONS	DATE			
PROJ. ENGR.	PROJ. ENGR.					
SUBMITTED BY	CHIEF SEC.					
EXAMINED BY	CHIEF ENGR.					
APPROVED BY	CHIEF DIV.					
NO SHEET						
LINE NO.	DRAWING NUMBER	N O M E N C L A T U R E		NUMBER REQUIRED PER TOTAL ASSY.	REMARKS	
1	C300.662	B CARRIER STOCK		-		
2	B300.663	B CARRIER		116		
3	C300.664	B ELECTRODE		55		
4	B300.665	B ELECTRODE ASSEMBLY		2		
5	D300.666	HEFTY		1		
6	C300.667	B PAD STOCK		-		
7	B300.668	B PAD		9		
8	B300.669	THICK WRAPPER		1		
9	B300.670	THIN WRAPPER		3		
10	D300.671	STACK ASSEMBLY		1		
11	D300.672	CAN AND STACK ASSEMBLY		1		
12	B300.673	PAD SEGMENT		1		
13	B300.674	THICK SPACER		2		
14	B300.675	THIN SPACER		1		
15	B300.676	ASBESTOS RAFFLE		1		
16	B300.677	MICA		3		
17	B300.678	FILLER		3		
18	B300.679	NOTCHED FILLER		4		
19	D300.680	FILLED CAN ASSEMBLY		1		
20	B300.681	COVER		1		
21	B300.682	PLATE		1		
22	B300.683	COVER WELDMENT		1		
23	B300.684	TERMINAL WIRE		3		
24	B300.685	LARGE SOLDER RING		3		
25	B300.686	TERMINAL WIRE		3		
26	B300.687	COVER ASSEMBLY		1		
27	B300.688	TERMINAL SHIELD		1		
28	B300.689	INNER SHIELD		1		
29	B300.690	SHIELDED COVER ASSEMBLY		1		
30	C300.691	UN-ARMED ASSEMBLY		1		
31	B300.692	CUP		1		
32	B300.693	ANVIL		1		
33	B300.694	PRIMER ASSEMBLY		1		
34	B300.695	WIRING DIAGRAM		-		
35	A300.107	BATTERY RETAINER		1	For Battery Assy	
36	B300.190	SPACER RING		1	For Battery Assy	
37						
NOTES: SPECIFICATIONS OF LATEST ISSUE APPLY						

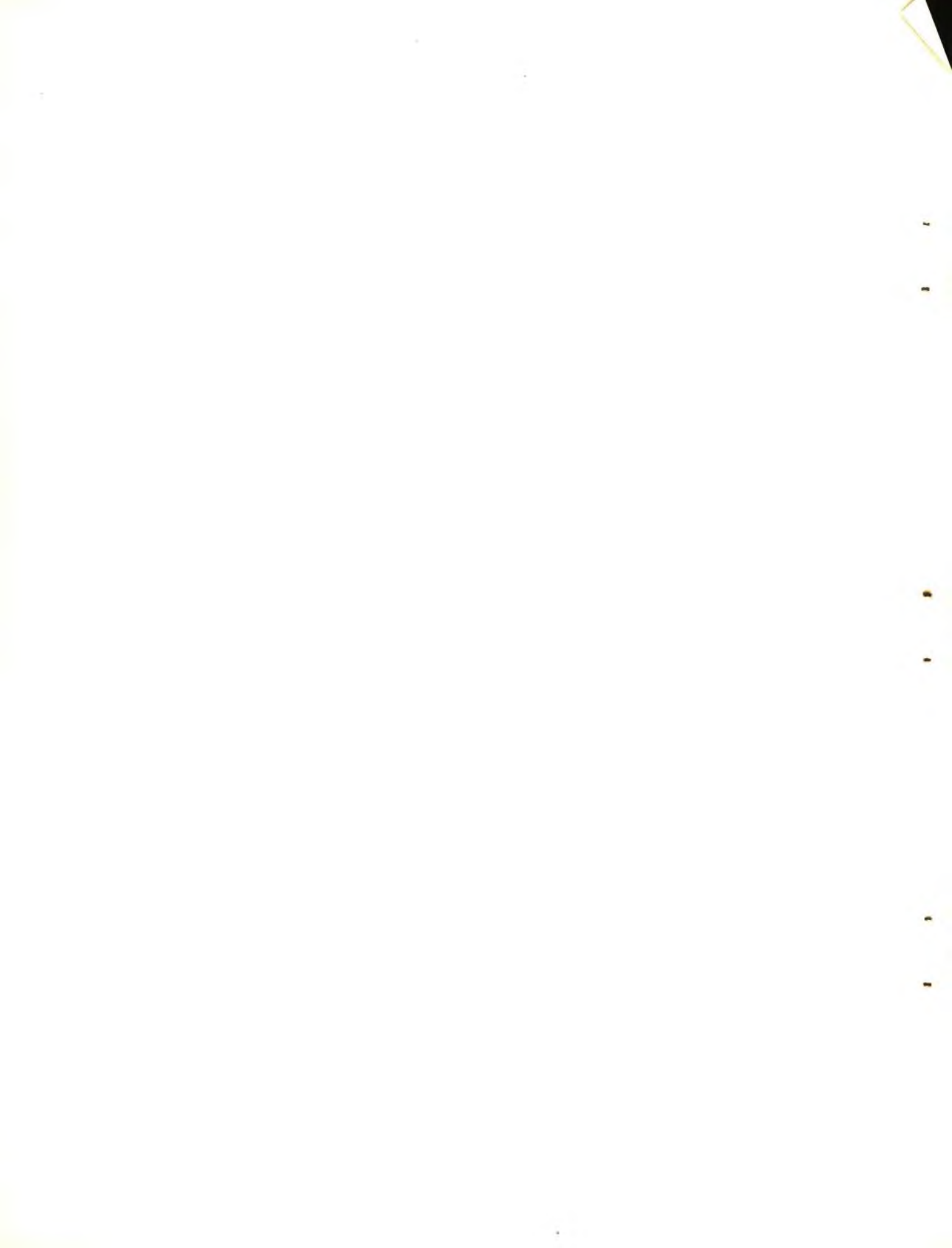

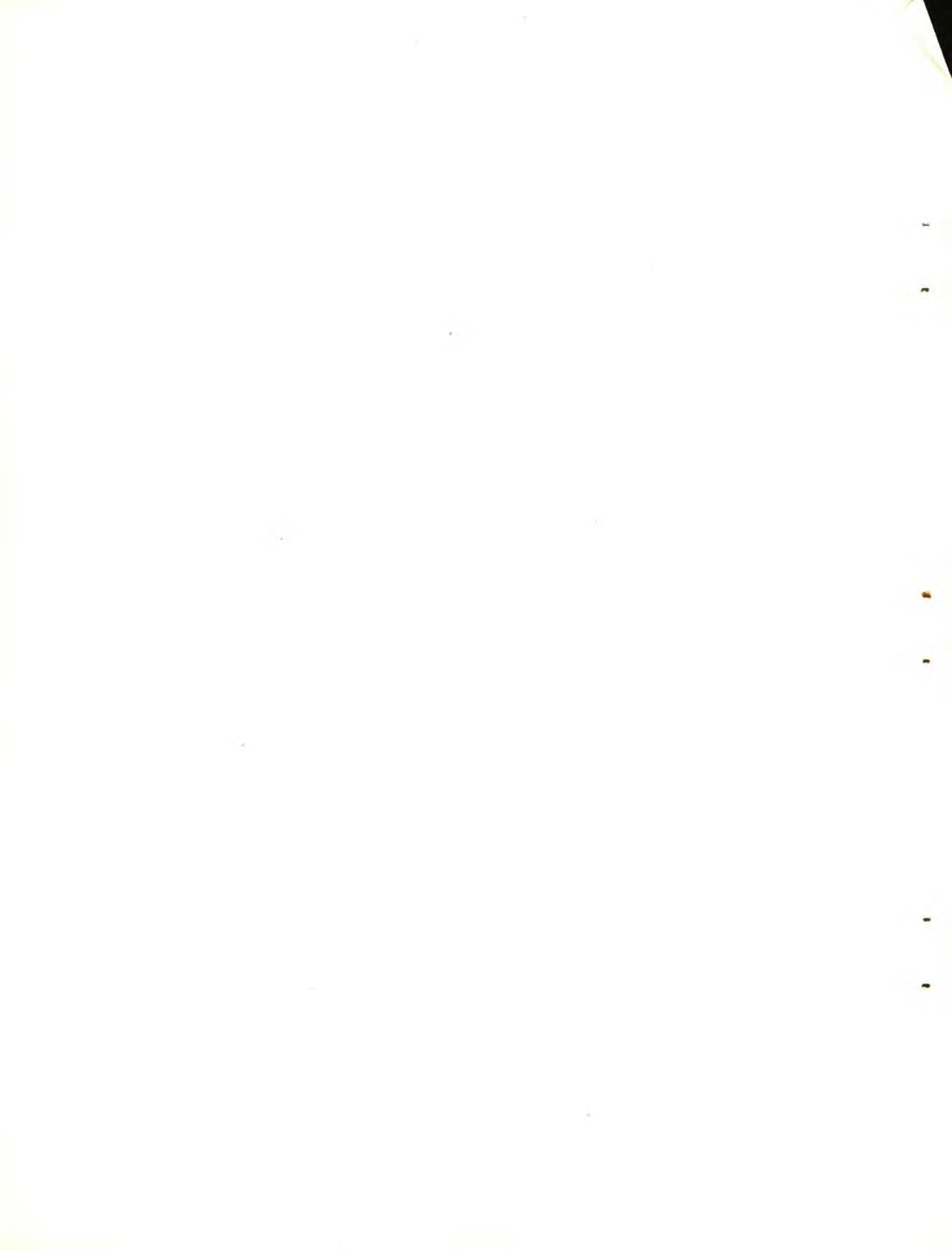

~~CONFIDENTIAL~~

CONFIDENTIAL <small>SECURITY INFORMATION</small>		DIAMOND ORDNANCE FUZE LABORATORY PROJECTILE FUZE LABORATORY		L. D. No. B-300484 SHEET 2 OF 4 SHEETS		
LIST OF DRAWINGS, PARTS AND SPECIFICATIONS				ORIGINAL DATE: 31 MAY 1955		
FOR: T-2061, SAFETY & FENCING TECHNIQUE						
DRAFTSMAN	CHECKER <i>WLD</i>	REVISIONS	NO.	SHEET	DATE	
PROJECT ENGR <i>WLD</i>	PROJ ENGR <i>RE</i>					
SUBMITTED BY	CHIEF SEC <i>RE</i>					
EXAMINED BY	CHIEF ENGR					
APPROVED BY	CHIEF DIV					
LINE NO.	DRAWING NUMBER	N O M E N C L A T U R E		NUMBER REQUIRED PER ASSY.	TOTAL	REMARKS
1	B-300,532	TCP PLATE ASSY		1		
2	B-300,533	TCI PLATE		1		
3	B-300,534	TCP PLATE PUSHING		1		
4	B-300,535	OUTER FRAME PLATE ASSY		1		
5	B-300,536	OUTER FRAME PLATE		1		
6	B-300,537	INSULATOR		1		
7	B-300,538	CONDUCTOR		1		
8	B-300,539	CONDUCTOR (DISCONNECT)		1		
9	B-300,540	SWITCH ASSY		1		
10	B-300,541	SWITCH BLADE		1		
11	B-300,542	SWITCH BRACKET		1		
12	B-300,543	TERMINAL PR/CNT		1		
13	B-300,544	TERMINAL SUB-ASSEMBLY		1		
14	B-300,545	SECTOR DRIVE WEIGHT ASSEMBLY		1		
15	B-300,546	SECTOR WEIGHT		1		
16	B-300,547	SECTOR GEAR		1		
17	B-300,548	AUXILIARY WEIGHT		1		
18	B-300,549	SECTOR HUB (GENEVA LOCK)		1		
19	B-300,550	LATCH PIN		1		
20	B-300,551	KICK PIN		1		
21	C-300,552	S.D. CLOCK ASSEMBLY		1		SEE DETAIL ELEMENT 553 - B-300,550
22	B-300,553	S.D. CLOCK PLATE, BOTTOM		1		
23	B-300,554	S.D. CLOCK PLATE, TOP		1		
24	B-300,555	S.D. CLOCK PLATE ASSY		1		
25	B-300,556	STAND OFF		4		
26	B-300,557	S.D. LEVER SHAFT		1		
27	B-300,558	IMPACT SPRING		1		
28	B-300,559	S.D. MAIN DRIVE SPRING		1		
29	B-300,560	S.D. MAIN SHAFT ASSY		1		
30	B-300,561	S.D. MAIN DRIVE GEAR		1		
31	B-300,562	S.D. MAIN SHAFT		1		
32	B-300,563	S.D. MAIN SHAFT PUSHING		1		
33	B-300,564	NO. 1 GEAR ASSY		1		
34	B-300,565	NO. 2 GEAR ASSY		1		
35	B-300,566	ESCAPE WHEEL ASSY		2		
36	B-300,567	PALLET ASSY		2		
37	B-300,568	NO. 3 GEAR ASSY		2		
NOTES:						

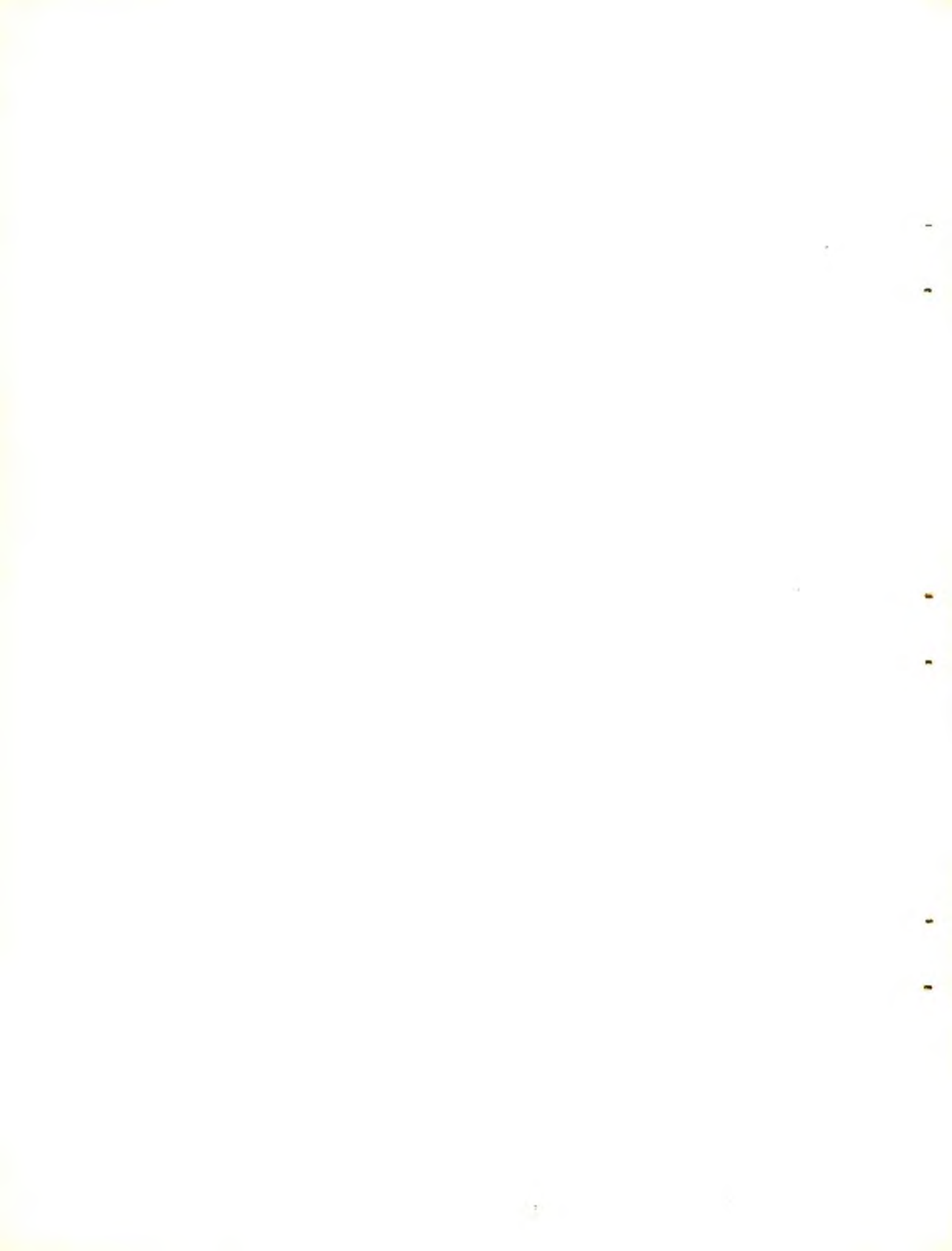

LIST OF DRAWINGS, PARTS AND SPECIFICATIONS FOR: T-2061, SAFETY & ARMING MECHANISM

ORIGINAL DATE: 31 MAY 1955

DRAFTSMAN	CHECKER <i>Wld</i>	REVISIONS	NO. SHEET	DATE
PROJ. ENGR. <i>NLN</i>	PROJ. ENGR. <i>R. G. ...</i>			
SUBMITTED BY	CHIEF SEC. <i>...</i>			
EXAMINED BY	CHIEF ENGR.			
APPROVED BY	CHIEF DIV.			

LINE NO.	DRAWING NUMBER	N O M E N C L A T U R E	NUMBER REQUIRED PER TOTAL ASSY.	REMARKS
1	B-300,569	PALLET	2	
2	B-300,570	PALLET ARBOR	2	
3	B-300,571	NO. 1 PINION	3	
4	B-300,572	NO. 2 PINION	2	
5	B-300,573	ESCAPE WHEEL	2	
6	B-300,574	GEAR NO. 1 & 2	2	
7	B-300,575	GEAR NO. 3	1	
8	B-300,576	S.D. LEVER ASSY	1	
9	B-300,577	S.D. LEVER	1	
10	B-300,578	S.D. LEVER BUSHING	1	
11	B-300,579	S.D. SPRING STUD	1	
12	B-300,580	S.D. LEVER SPRING	1	
13	B-300,581	IMPACT LEVER ASSY	1	
14	B-300,582	IMPACT LEVER	1	
15	B-300,583	IMPACT WEIGHT	1	
16	B-300,584	IMPACT WEIGHT STUD	1	
17	B-300,585	IMPACT LEVER BUSHING	1	
18	B-300,586	PRIMER STRIKER STOP	1	
19	B-300,587	S.D. LEVERLOCK SPRING	1	
20	B-300,588	DELAY TRIP ASSY	1	
21	B-300,589	DELAY CLOCK PLATE ASSY	1	
22	B-300,590	DELAY CLOCK PLATE	1	
23	B-300,591	FIRING PIN (BATTERY STRIKER)	1	
24	B-300,592	FIRING PIN SPRING	1	
25	B-300,593	BATTERY STRIKER	1	
26	B-300,594	SETBACK SPRING	1	
27	B-300,595	GROUNDING CLIP	1	
28	B-300,596	S.D. MAIN DRIVE GEAR, BASIC GEAR DATA	1	
29	B-300,597	GEAR NO. 1 & 2, BASIC GEAR DATA	1	
30	B-300,598	GEAR NO. 3, BASIC GEAR DATA	1	
31	B-300,599	SECTOR GEAR, BASIC GEAR DATA	1	
32	B-300,600	PINION GEAR, BASIC GEAR DATA	1	
33	B-300,605	DETONATOR RETAINER	1	
34	A-300,375	PRIMER RETAINER	1	
35				
36				
37				

NOTES:

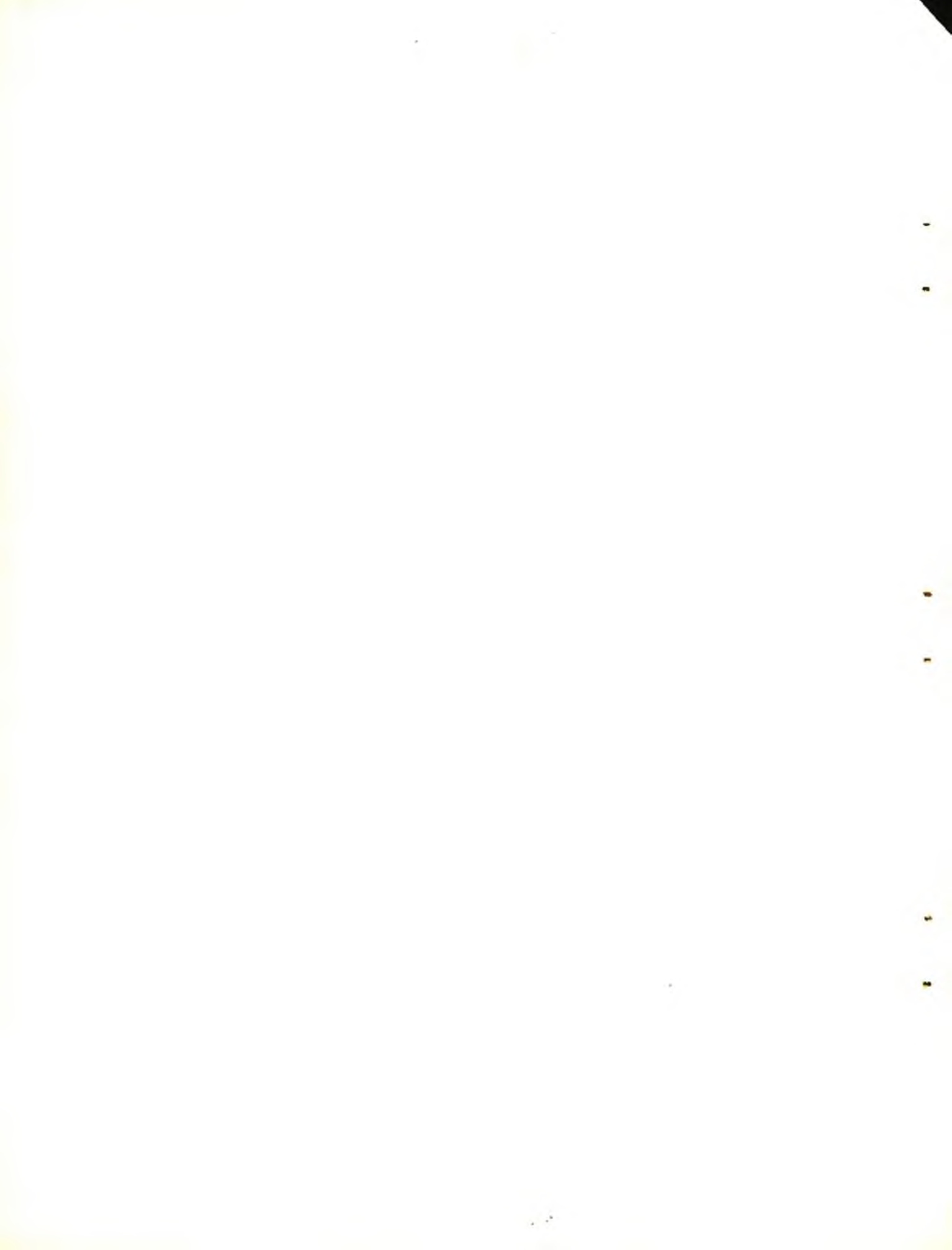

~~CONFIDENTIAL~~

SECURITY INFORMATION	DIAMOND ORDNANCE FUZE LABORATORY PROJECTILE FUZE LABORATORY	L. D. No. B-300484 SHEET 4 OF 4 SHEETS
----------------------	--	---

LIST OF DRAWINGS, PARTS AND SPECIFICATIONS	ORIGINAL DATE:
FOR: T-2061, SAFETY & ARMING MECHANISM	

DRAFTSMAN	CHECKER	PROJ ENGR	SUBMITTED BY	EXAMINED BY	APPROVED BY	NO.	SHEET	DATE	REVISIONS

LINE NO.	DRAWING NUMBER	N O M E N C L A T U R E	NUMBER REQUIRED PER ASSY.	REMARKS
1		IMPACT ELEMENT ASSEMBLY		
2	C-300,601	IMPACT ELEMENT ASSEMBLY	1	
3	B-300,602	BUFFER BRACKET	1	
4	B-300,603	STOP OFF	1	
5	B-300,604	SPACER	1	
6	B-300,551	IMPACT LEVER ASSY	1	
7	B-300,558	IMPACT SPRING	1	
8	B-300,555	S. D. CLOCK PLATE ASSY	1	
9	B-300,553	S. D. CLOCK PLATE (BOTTOM)	1	
10				
11		MECHANICAL COMMERCIAL PARTS		
12		Tinnerman Products, Cleveland, Ohio, Tabular Clip C2733-051-2		
13		or Equal	1	For T-300,532 (For Flight Assy)
14		Flat Flanged Eyelet, A1486	7	
15		Flat Flanged Eyelet, A1523	1	For T-300,540 Switch Assy.
16		Edwin E. Stimpson Co., Inc. Brooklyn, N.Y. or Equal		
17		Retaining Ring Type-E, 5133-6-S	1	B-300,515
18		Retaining Ring, Type-E, 5133-9-S	1	B-300,557 & B-300,560
19		Waldee Robinson Inc. Long Island City, N.Y. or Equal		
20		Lockwasher, Type 19 Internal Tooth For No. 2 Screw,	6	For C-300,552, B-300,588 & B-300,535
21		"Shakerproof" or Equal		
22		Roll Pin, Elastic Stop Nut Corp., New Jersey or Equal	2	
23		No. 4-40 NC-2, 1/4"-Long, Flat Head Mech. Screw Cadmium Plate	1	For B-300,496
24		No. 3-48 NC-2, 3/16"-Long, Flat Head Mech. Screw Cadmium Plate	3	For B-300,532 & B-300,496
25		No. 2-56 NC-2, 7/16"-Long, Round Head Mech. Screw Cadmium Plate	3	For C-300,552 & T-300,560
26		No. 2-56 NC-2, 1/4"-Long, Round Head Mech. Screw Cadmium	2	For B-300,535
27		No. 2-56 NC-2, 1/8"-Long, Binding Head Mech. Screw Cadmium Plate	1	For T-300,595
28		No. 2-56 NC-2, 7/16"-Long, Fillister Head Mech. Screw Cadmium	1	For C-300,552
29		Plate		
30		No. 2-56 NC, 3/16"-Long, Fillister Head Mech. Screw Cadmium	1	For T-300,540
31		Plate		
32				
33		SPECIFICATIONS OF LATEST ISSUE APPLY		
34				
35				
36				
37				

NOTES:

~~CONFIDENTIAL~~



UNCLASSIFIED
SECURITY INFORMATION

DIAMOND ORDNANCE FUZE LABORATORY
PROJECTILE FUZE LABORATORY

L. D. No. B-300485
SHEET 1 OF 1 SHEETS

LIST OF DRAWINGS, PARTS AND SPECIFICATIONS

ORIGINAL DATE:
31 MAY 1955

FOR: ARMING CHAMBER

DRAFTSMAN	CHECKED <i>NLR</i>	REVISIONS	NO	SHEET	DATE
PROJ. ENGR	PRJ. ENGR <i>RE</i>				
SUBMITTED BY	CHIEF SEC <i>RE</i>				
EXAMINED BY	CHIEF ENGR				
APPROVED BY	CHIEF LTY				

LINE NO.	DRAWING NUMBER	N O M E N C L A T U R E	NUMBER REQUIRED		REMARKS
			PER ASSY.	TOTAL	
1	C-300.411	ARMING CHAMBER WELDMENT	1		
2	C-300.412	BASE	1		
3	C-300.413	ARMING CHAMBER	1		
4	B-300.414	RAFFLE SUPPORT	1		
5	B-300.415	BUFFLE	1		
6	B-300.416	S. D. SELECTOR BARREL	1		
7	B-300.417	S. D. SELECTOR	1		
8	A-300.418	DOWEL PIN (LONG)	1		
9	A-300.419	DOWEL PIN (SHORT)	1		
10	A-300.423	FAD	1		
11	C-300.425	SLEEVE	1		
12	A-300.463	S. D. SELECTOR LIMIT PIN	1		
13	C-300.464	ARMING CHAMBER ASS'Y	1		
14	B-300.491	CAP	1		
15	B-300.619	SIZE 1.3765 "Co" & 1.3870 "Co"	1		For C-300.411
16	B-300.620	SIZE .4845, 1.7155 "Co" & .4915, 1.7358 "Co"	1		For C-300.411
17	B-300.621	SIZE 45° & 127° ANGULAR RILL TIEWEL	1		For C-300.411
18					
19					
20		MECHANICAL COMMERCIAL PARTS			
21		Precision Rubber Products Corp.			
22		"O Rings" Dayton 7, Ohio, or Equal			
23					
24		"O" Ring No. 902 1/2 - 1/16 I.D. x 1/8 O.D. x 1/32	1		
25		"O" Ring No. 414 - 41 - 2 5/16 I.D. x 2 1/2 O.D. x 3/32	1		
26					
27		Trust's Retaining Ring, Waldes Kohinoor Inc.			
28		Long Island City, New York, or Equal			
29		Retaining Ring No. 5103 - 12-C Beryllium Copper	1		
30					
31		NOTE			
32		SPECIFICATIONS OF LATEST ISSUE APPLY			
33					
34					
35					
36					
37					

NOTES:

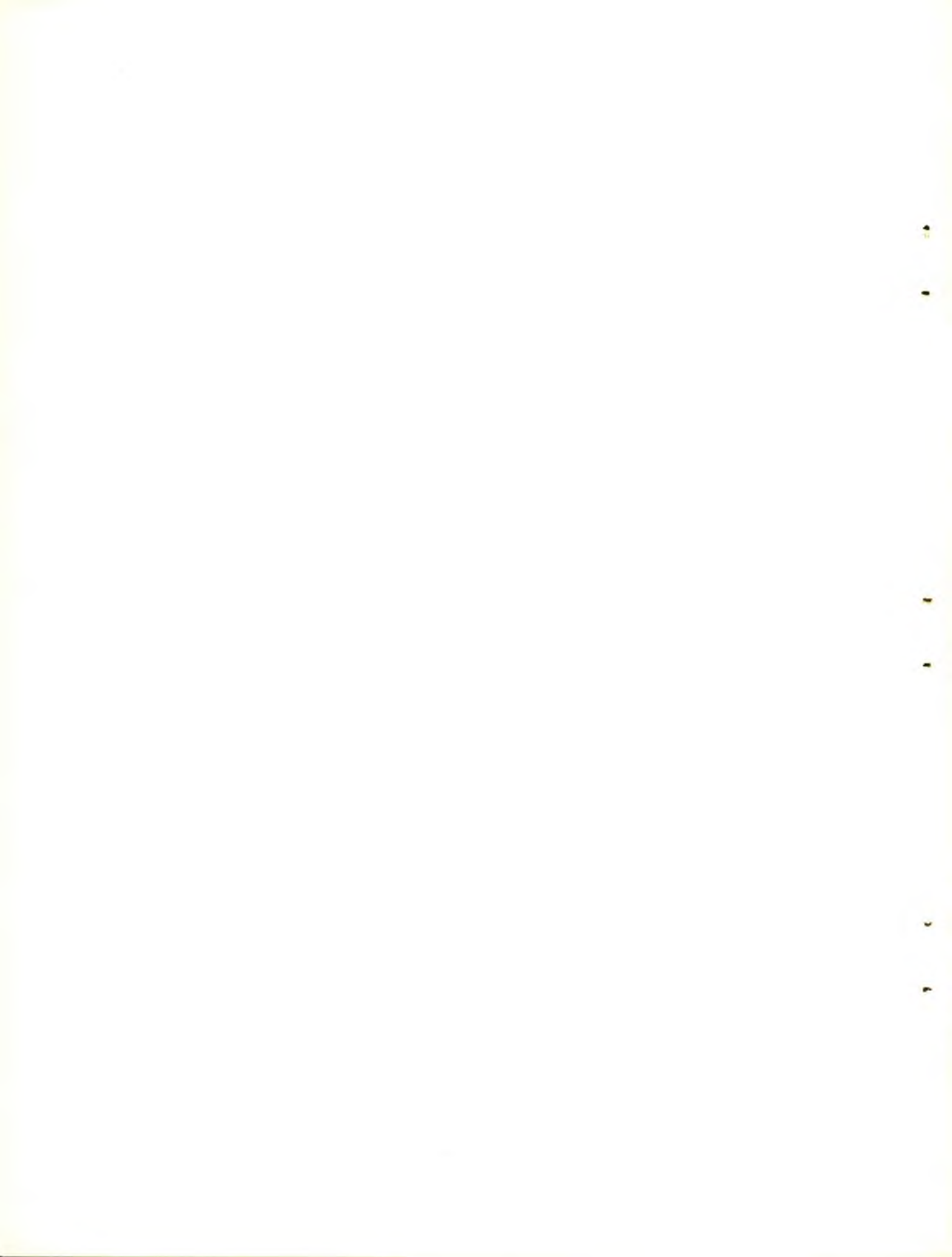

UNCLASSIFIED <small>SECURITY INFORMATION</small>		DIAMOND ORDNANCE FUZE LABORATORY PROJECTILE FUZE LABORATORY		L. D. No. B-300,486 SHEET 1 OF 1 SHEETS	
LIST OF DRAWINGS, PARTS AND SPECIFICATIONS FOR: T-97 STAB PRIMER				ORIGINAL DATE: 31 MAY 1955	
DRAFTSMAN		CHECKER <i>N/A</i>		REVISIONS NO. SHEET DATE	
PROJ. ENGR. <i>N/A</i>		PROJ. ENGR. <i>N/A</i>			
SUBMITTED BY		CHIEF SEC.			
ENGINEER BY		CHIEF ENGR.			
APPROVED BY		CHIEF CIV.			
LINE NO.	DRAWING NUMBER	N O M E N C L A T U R E	NUMBER REQUIRED		REMARKS
			PER ASSY.	TOTAL	
1	R-300,369	T-97 STAB PRIMER	1		
2	A-300,370	ENTER DISC	1		
3	A-300,371	STOPPING DISC	1		
4	A-300,372	PRIMER CUP	1		
5	A-300,492	PRIMER MIXTURE	1		
6					
7					
8					
9					
10					
11					
12					
13					
14					
15					
16					
17					
18		SPECIFICATIONS OF LATEST ISSUE ONLY			
19					
20					
21					
22					
23					
24					
25					
26					
27					
28					
29					
30					
31					
32					
33					
34					
35					
36					
37					
NOTES:					

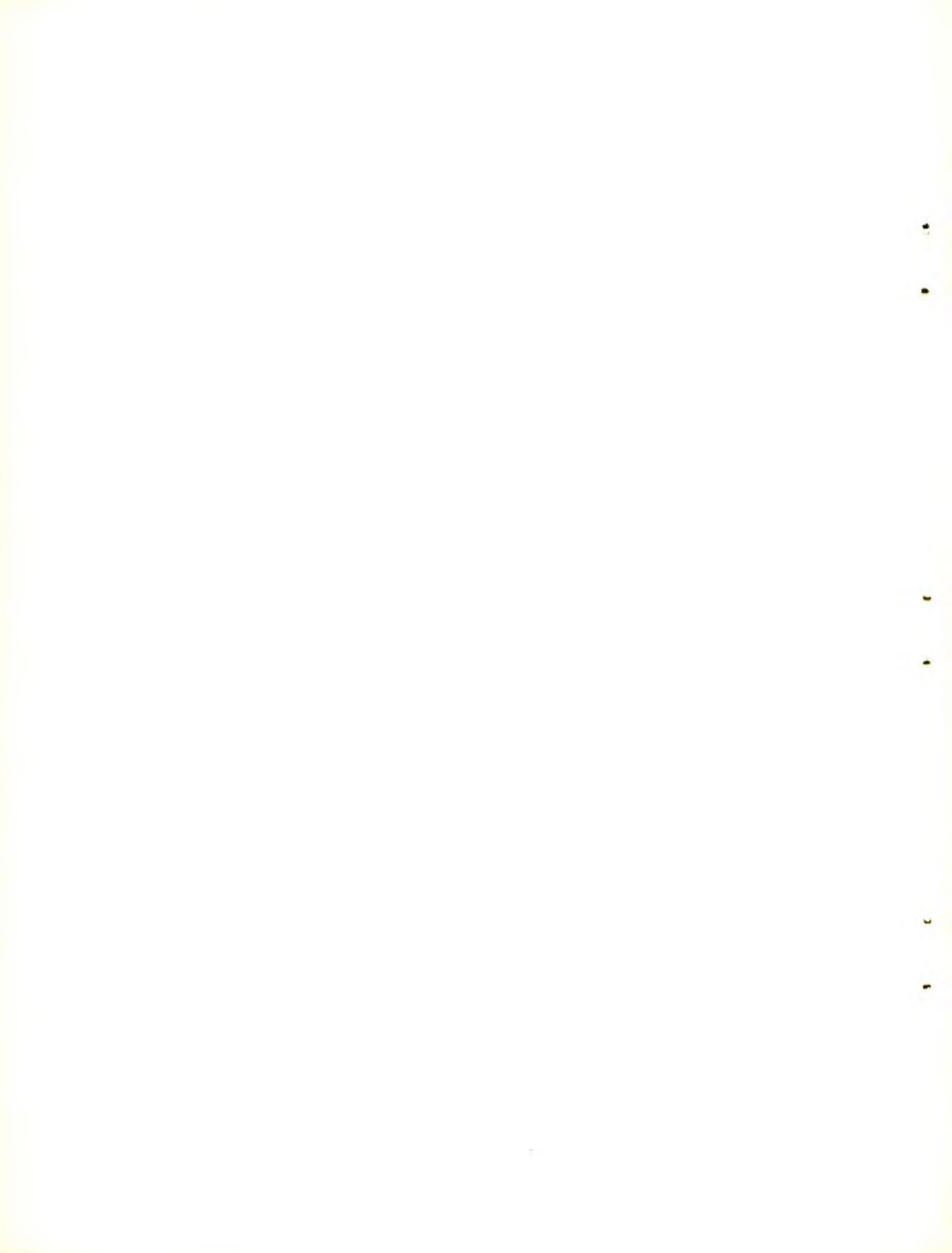

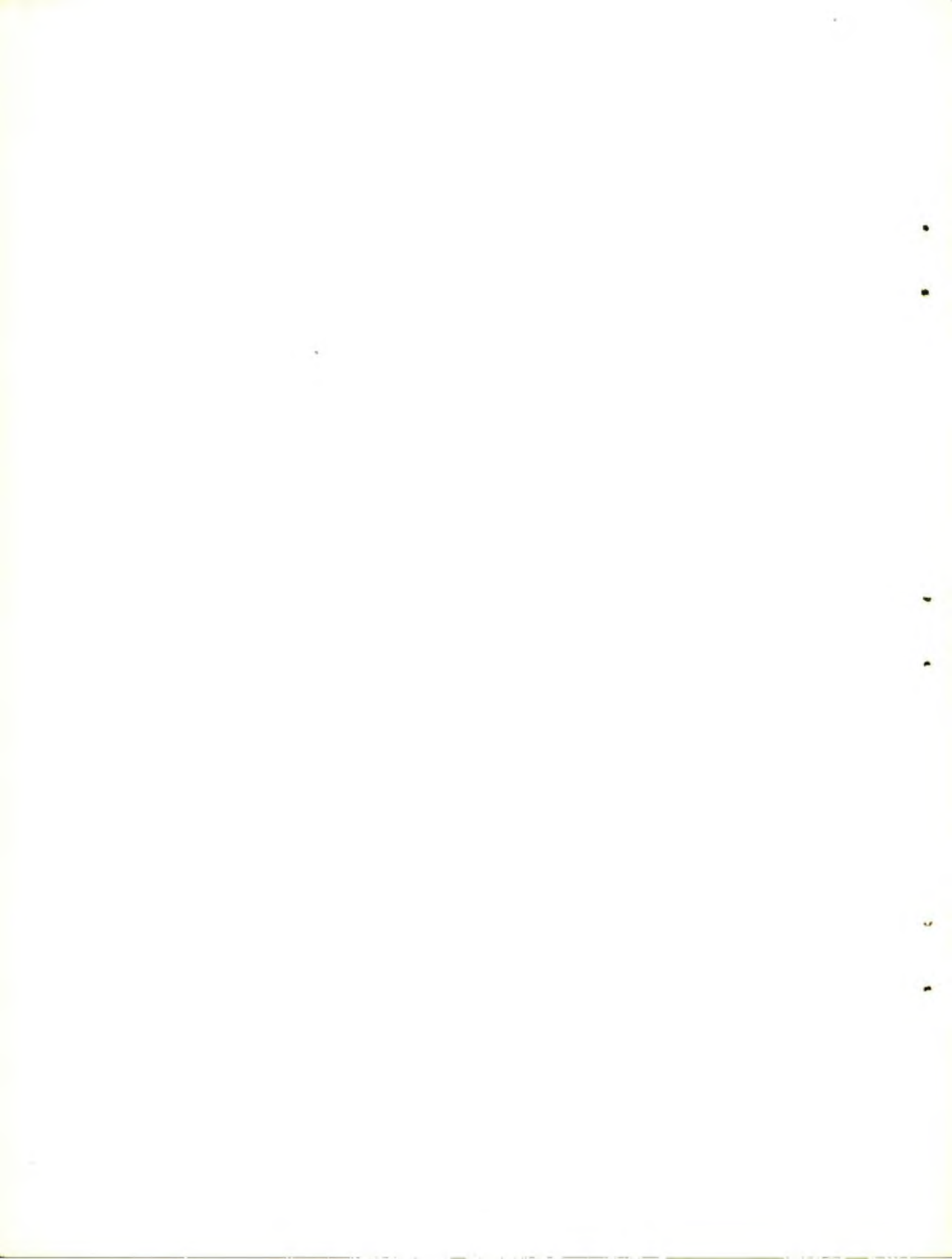

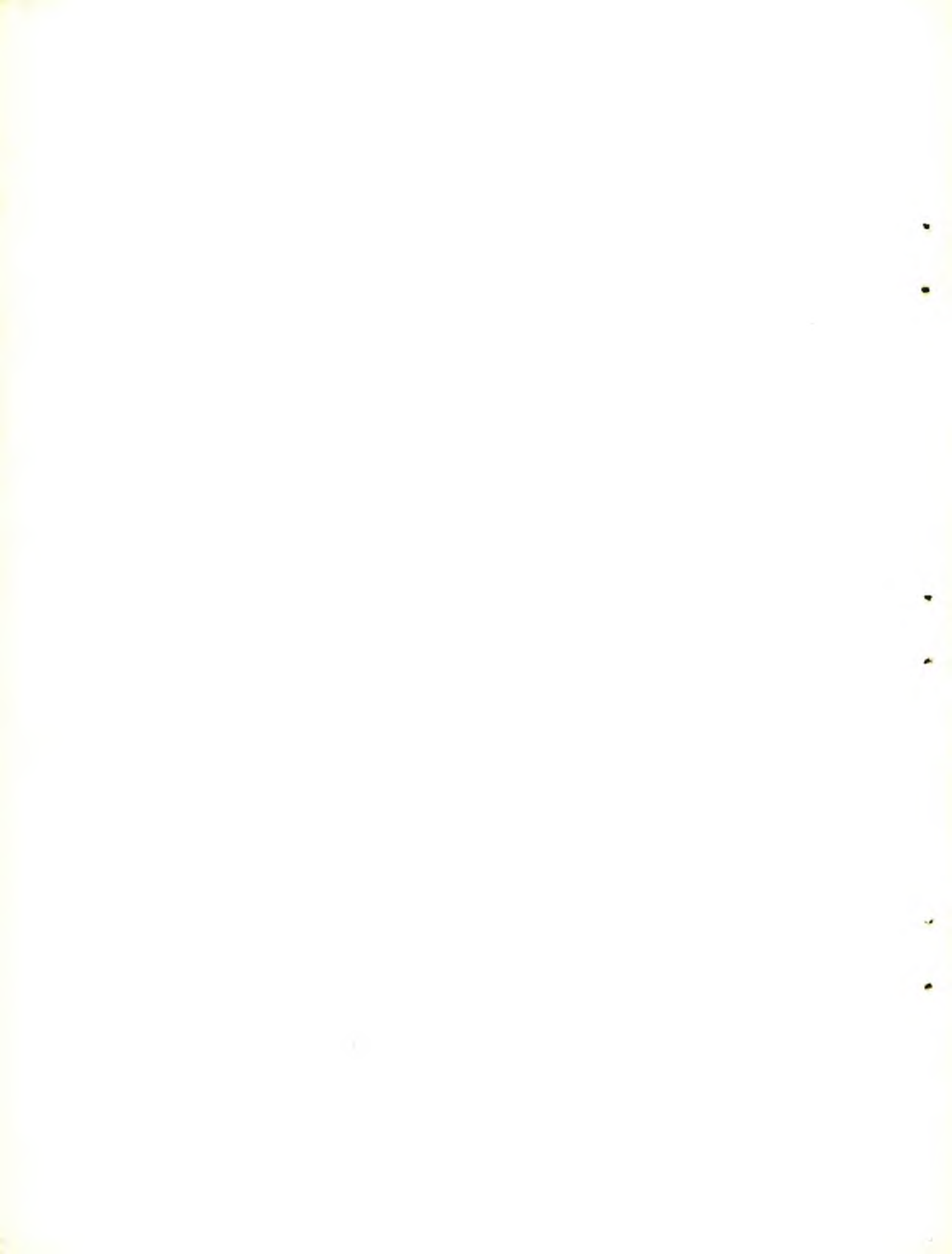

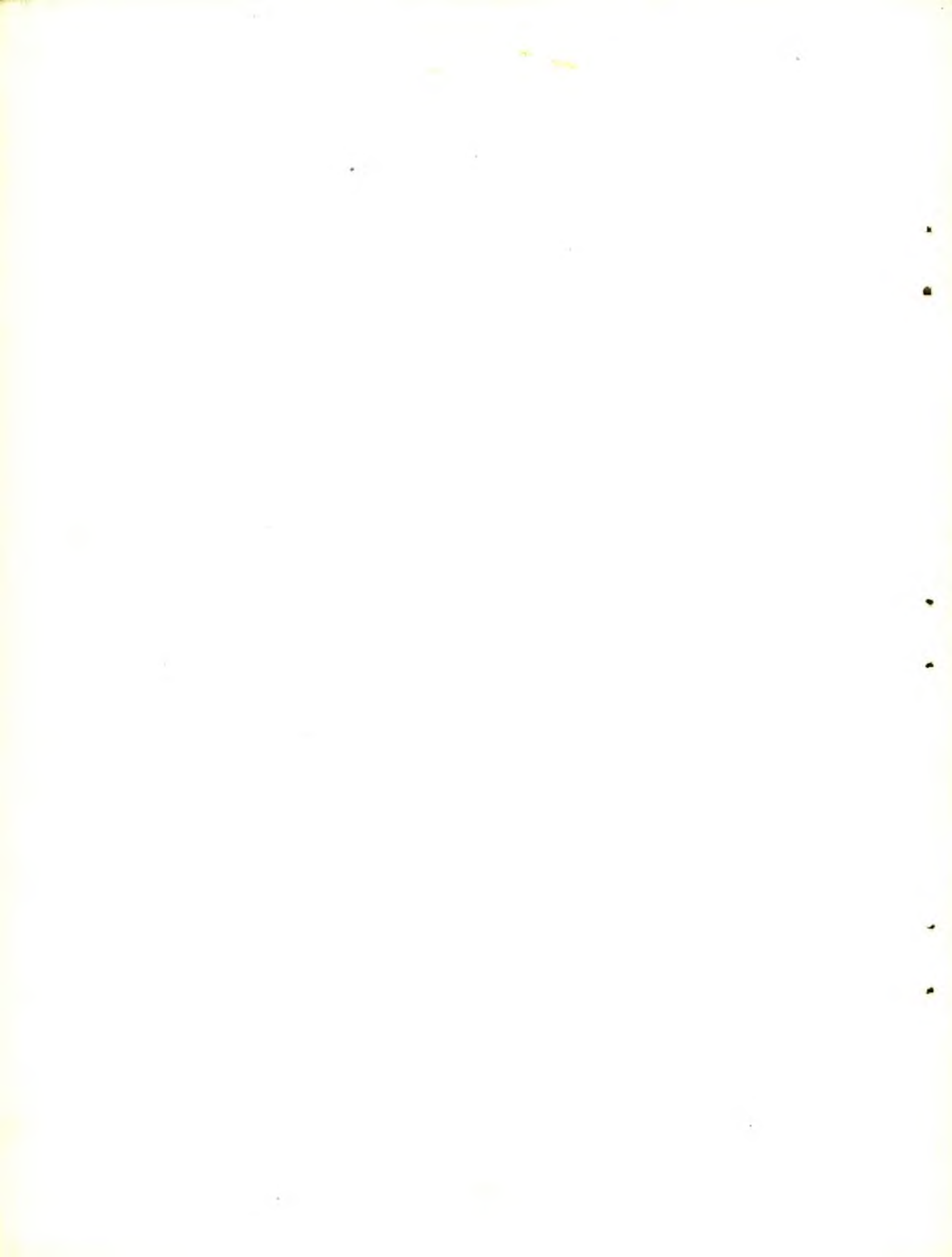

DISTRIBUTION

Copies	1	-	10	ORDTA
			11	ORDIM
			12	ORDTU
	13	-	14	Navy BuOrd, Re2b - Comdr. W. B. Rodman
			15	USAF Headquarters
			16	ARDC (Baltimore)
	17	-	18	Wright Air Development Center - WCEGO
			19	Wright Air Development Center - WCLGW
	20	-	22	VT Fuze Division, NOL - Mr. R. C. Daniel
			23	Naval Ordnance Testing Station - Attn: Code 40
			24	AFAC, Eglin Field - Commanding Officer
			25	Redstone Arsenal - Commanding General
			26	Eastman Kodak - Dr. Totter
			27	Airborne Instruments Lab - Dr. Skifter
			28	Emerson Radio and Phonograph Corp - Mr. Berkoff
			29	University of Florida - Mr. Tedder
			30	Hinman 01.2
			31	Guarino 20.0
			32	Laboratory 40 Library
			33	Kalmus 50.0
			34	Lapham 21.0
			35	Rubinowitz 22.0
			36	Godfrey 23.0
			37	Fraumann 61.0
			38	Williams 21.3
			39	Oertel 21.1
			40	Scillian 22.4
			41	Ebner 22.6
			42	Vorkink 20.02
	43	-	44	DOFL Library
	45	-	48	DOFL File 06.3

To Contractors who are furnished this Report:

This report is on loan only and must be returned to the Government agency from which it was received upon completion of the contract(s) to which this material pertains.