

UNCLASSIFIED

AD 429314

DEFENSE DOCUMENTATION CENTER

FOR

SCIENTIFIC AND TECHNICAL INFORMATION

CAMERON STATION, ALEXANDRIA, VIRGINIA



UNCLASSIFIED

NOTICE: When government or other drawings, specifications or other data are used for any purpose other than in connection with a definitely related government procurement operation, the U. S. Government thereby incurs no responsibility, nor any obligation whatsoever; and the fact that the Government may have formulated, furnished, or in any way supplied the said drawings, specifications, or other data is not to be regarded by implication or otherwise as in any manner licensing the holder or any other person or corporation, or conveying any rights or permission to manufacture, use or sell any patented invention that may in any way be related thereto.

64-8



TR-1155

CATALOGED BY DDC
AS AD No. 429314

429314

SUMMARY REPORT

FUZE, PIBD, T278E8

Louis Richmond

30 October 1963



HARRY DIAMOND LABORATORIES
FORMERLY: DIAMOND ORDNANCE FUZE LABORATORIES
ARMY MATERIEL COMMAND

WASHINGTON 25. D. C.

HARRY DIAMOND LABORATORIES

Milton S. Hochmuth
Lt. Col, Ord Corps
Commanding

B. M. Horton
Technical Director

MISSION

The mission of the Harry Diamond Laboratories is:

(1) To perform research and engineering on systems for detecting, locating, and evaluating targets; for accomplishing safing, arming, and munition control functions; and for providing initiation signals: these systems include, but are not limited to, radio and non-radio proximity fuzes, predictor-computer fuzes, electronic timers, electrically-initiated fuzes, and related items.

(2) To perform research and engineering in fluid amplification and fluid-actuated control systems.

(3) To perform research and engineering in instrumentation and measurement in support of the above.

(4) To perform research and engineering in order to achieve maximum immunity of systems to adverse influences, including counter-measures, nuclear radiation, battlefield conditions, and high-altitude and space environments.

(5) To perform research and engineering on materials, components, and subsystems in support of above.

(6) To conduct basic research in the physical sciences in support of the above.

(7) To provide consultative services to other Government agencies when requested.

(8) To carry out special projects lying within installation competence upon approval by the Director of Research and Development, Army Materiel Command.

(9) To maintain a high degree of competence in the application of the physical sciences to the solution of military problems.

The findings in this report are not to be construed as an official Department of the Army position.

UNITED STATES ARMY MATERIEL COMMAND
HARRY DIAMOND LABORATORIES
WASHINGTON 25, D.C.

DA-5050201909
AMCMS Code 5530.12.54010
HDL Proj. 43500

TR-1155

30 October 1963

SUMMARY REPORT

FUZE, PIBD, T278E8

Louis Richmond

FOR THE COMMANDER:
APPROVED BY

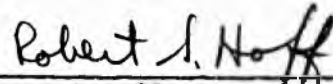
Robert Hoff
Chief, Laboratory 400



Qualified requesters may obtain copies of this report from Defense
Documentation Center 5010 Duke Street, Alexandria, Virginia.

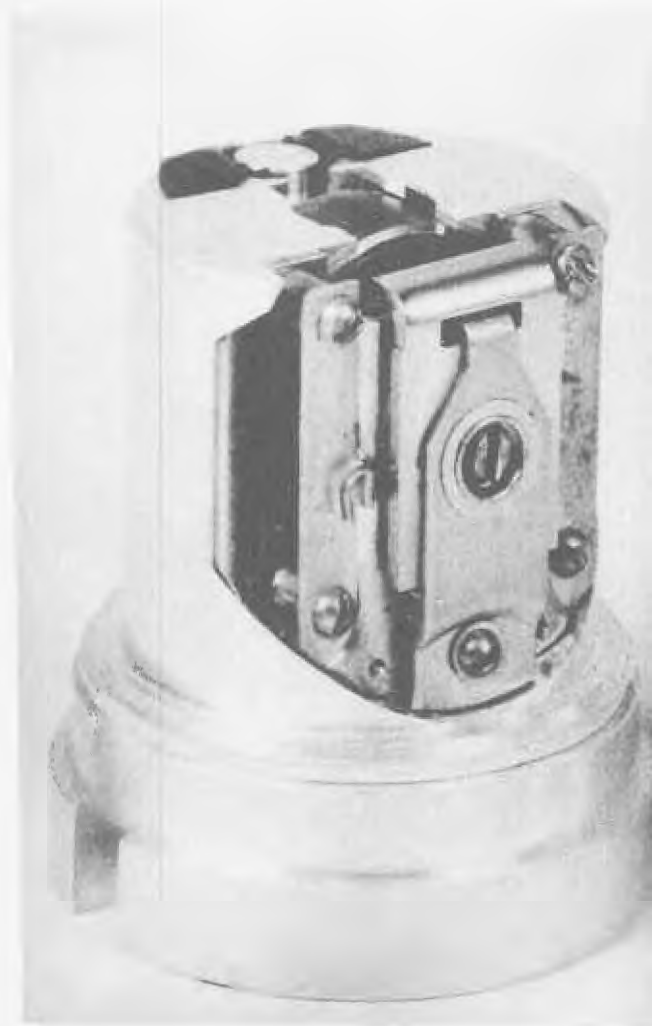

Frontispiece. T278E8 PIBD fuze-



1320-63

-shown without shield and fully assembled.

CONTENTS

ABSTRACT	7
1. INTRODUCTION	7
2. DESCRIPTION OF BASIC DESIGNS	7
2.1 M509 Fuze	7
2.2 M530 (T278E7 Fuze)	9
3. REQUIREMENTS ESTABLISHED FOR T278E8 FUZE	11
3.1 General Design Considerations	11
3.2 Arming Delay Requirements	12
3.3 Sensitivity	12
4. T278E8 DEVELOPMENTAL HISTORY	13
4.1 General Design Description	13
4.2 Design Modifications	13
4.2.1 Tracked Rotor Design	13
4.2.2 Ratchet Delay Design	19
4.2.3 Starwheel and Pallet Delay	19
4.2.4 Modified Starwheel and Pallet Delay	21
4.2.5 Mechanical Escapement Delay—Zenith Design	21
4.2.6 Assembly of Shield to Rotor Housing	26
5. PERFORMANCE	26
5.1 Engineering Design Tests	26
5.1.1 Arming Distance of Fuze-Shell Combination	26
5.1.2 Arming Distance of Tracked Rotor and Ratchet and Spring Designs	29
5.1.3 Modified Starwheel and Pallet Delay	29
5.1.4 Zenith Escapement Design	31
5.1.5 Arming Distance Tests in M371 Shell at APG	32
5.1.6 Graze Element Sensitivity Test	34
5.1.7 Firing Test in T300E56 at APG	34
5.1.8 Laboratory Investigation of Malfunction in T30056 Shell	34
5.1.9 MIL-STD Tests	35
5.2 Engineering Tests	35
5.2.1 Armor Plate Impact Reliability Test	36
5.2.2 Arming Delay	36
5.2.3 Graze Sensitivity	36
5.2.4 Impact Sensitivity	37
5.2.5 Parachute Delivery Tests	38
5.3 Discussion of Performance	38
5.3.1 Graze Element	38
5.3.2 Arming Delay	39
5.4 Safety	42
6. CONCLUSIONS	42

Figure No.		Page No.
Frontispiece.	T278E8 PIBD Fuze--shown without shield and fully assembled.	3
1	T278E7 (M530) and -E8 PIBD fuzes.	8
2	Sequential leaf setback release mechanism . . .	10
3	Exploded view of T278E8 fuze.	14
4	Line drawing of T278E8 fuze (armed)	15
5	Line drawing of rotor housing release assembly (unarmed).	16
6	Circuit diagram of T278E8 fuze and shell assembly	17
7	Diagram showing tracked rotor design (bottom view).	18
8	Starwheel and pallet design	20
9	Modified starwheel and pallet design.	22
10	Pallet designs tested during T278E8 development	24
11	Graph showing frequency distribution of static rotor arming time of T278E8.	27
12	Rotor housings designed for knurl press assembly and 360-deg crimp assembly of shield	28
13	Drag deceleration effect (simulated by centrifuge) on T278E8 rotor arming time.	30
14	Static rotor arming time versus temperature for T278E8 fuze.	33
15	Arming delay characteristics at +160°F and room temperature.	40
16	Arming delay characteristics at -40°F and room temperature.	41

ABSTRACT

Development and performance of the T278E8 point-initiated, base-detonating (PIBD) fuze are summarized. The fuze (standardized M530A1) was designed primarily for use in the M371 90-mm recoilless HEAT cartridge, but may also be used in other low and intermediate velocity HEAT shells whose drag does not exceed about 20 g.

The performance characteristics of the T278E8 are compared with those of the M509E6 and M530 standard electric PIBD fuzes. These fuzes, which have been available for HEAT ammunition in the 76- to 120-mm range, are essentially similar in basic design and operation to the T278E8. The major difference is that the T278E8 fuze provides a minimum of 30 ft delayed arming in the M371 round, a feature that is not attainable by the other standard PIBD fuzes.

1. INTRODUCTION

The M371 90-mm recoilless round requires a minimum arming distance of 30 ft.^{1,2} This was not attainable with the two standard electric PIBD fuzes, the M509E6 and M530. Therefore, development of the T278E8 was initiated by HDL (then Diamond Ordnance Fuze Laboratories) in 1959, with the design objective of modifying the M530 fuze (fig. 1) by employing a mechanical rotor delay device capable of satisfying the arming distance requirement.

The T278E8 passed the ET phase (Engineering Test) in 1962, and was made standard A for the M371 cartridge in March 1963, with standard nomenclature of "Fuze, Point Initiated, Base Detonating, M530A1".³

2. DESCRIPTION OF BASIC DESIGNS

2.1 M509 Fuze

The M509-type fuze was developed during the period 1950-53. The M509-type fuze consists essentially of:

(1) A setback-actuated arming device, comprising three interlocked sequentially operating leaves. The first two of these leaves are restrained by springs so that a minimum acceleration of 2500 to 4000 g is required to permit arming.

¹OTCM 35040, dtd 5 Nov 1953.

²U.S. Army Infantry Board Report, Project Nr. 2757, "Service Test Of Rifle, 90-mm, T219E4, and Ammunition," 24 Mar 1958.

³AMC TC 642, dtd 21 Mar 1963.

T278E7 fuze (M530) in safe position

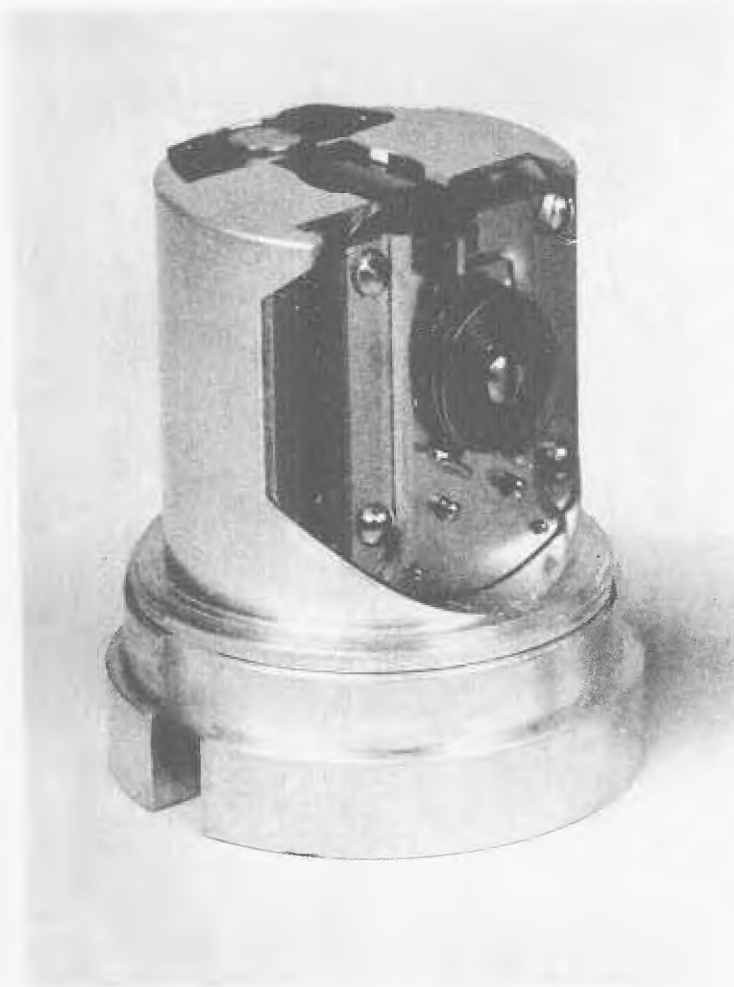

T278E8 fuze in armed position

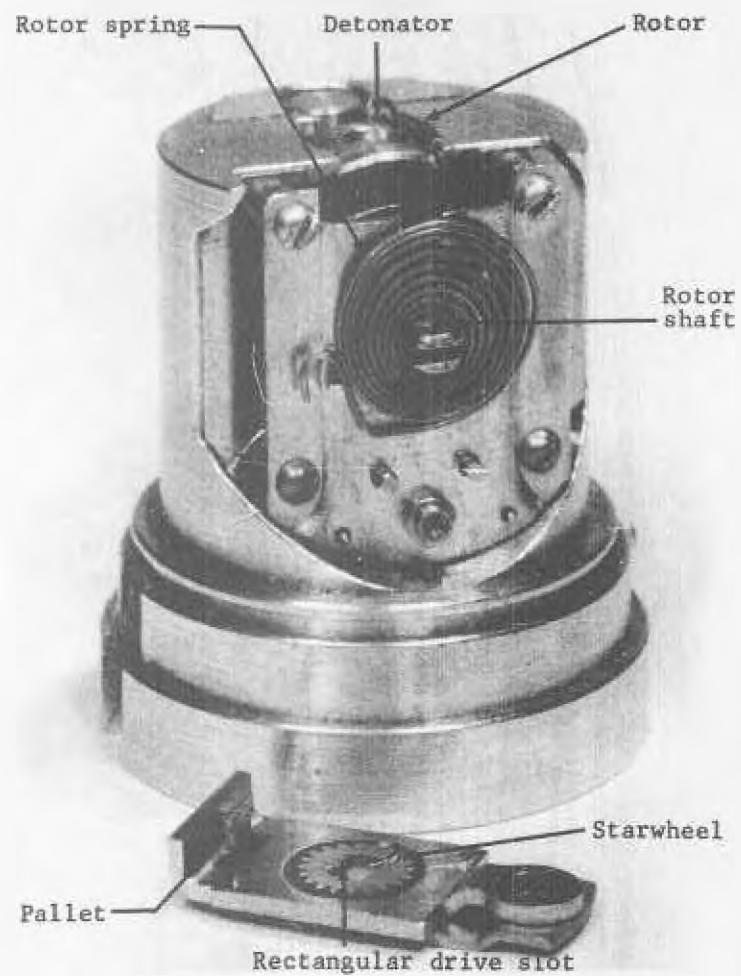

Figure 1. T278E7 (M530) and -E8 PIBD fuzes.

1321-63

(2) A rotor that carries an electric detonator, which in the safe position is 90 deg out of line with the tetryl lead and booster. In the safe position, the detonator is short circuited by grounding its insulated lead to the rotor housing.

When the fuze is subjected to a sustained acceleration of sufficient magnitude (2500 to 4000 g), the leaves are sequentially depressed until the third leaf unlatches the rotor. In the M509E4 and subsequent fuze modifications, this leaf is latched in the depressed position by an antireset spring, which was added to prevent the leaf from rebounding to the safe position and relatching the rotor in a high-acceleration shell. (This antireset spring, as used in the M530 design, is shown in figure 2.)

When the firing acceleration has diminished to a low value (< 100 g), the rotor is turned 90 deg by a torsion spring to align the electric detonator with the tetryl lead and booster. At the same time, an electric circuit is completed between the detonator and piezoelectric power source in the nose of the shell. This piezoelectric element provides the energy to initiate the detonator when the shell impacts a target.

The M509-type fuze is subject to several limitations:

(1) It has no self-contained means of initiation; the fuze is entirely dependent on the external piezoelectric element for function. Therefore, the fuze is not graze sensitive, except to the extent that the piezoelectric element may be sufficiently stressed on grazing impact to cause fuze initiation. This does not normally occur, especially in lower-velocity shell such as the M371.

(2) The static arming time does not exceed approximately 9 msec, which is far too short to provide sufficient delayed arming for low- and intermediate-velocity HEAT ammunition.

(3) The sequential leaf system is only marginally safe in aerial delivery (fouled parachute) and 40-ft drop tests.

2.2 M530 (T278E7) Fuze

The M530 fuze was developed by HDL during 1955-58 to overcome the limitations of the M509 when used with the M371 cartridge. The M530 design differs from the M509 type:

(1) It includes a self-contained inertia-sensitive mechanical graze initiation device in addition to the normal provision for piezoelectric initiation.

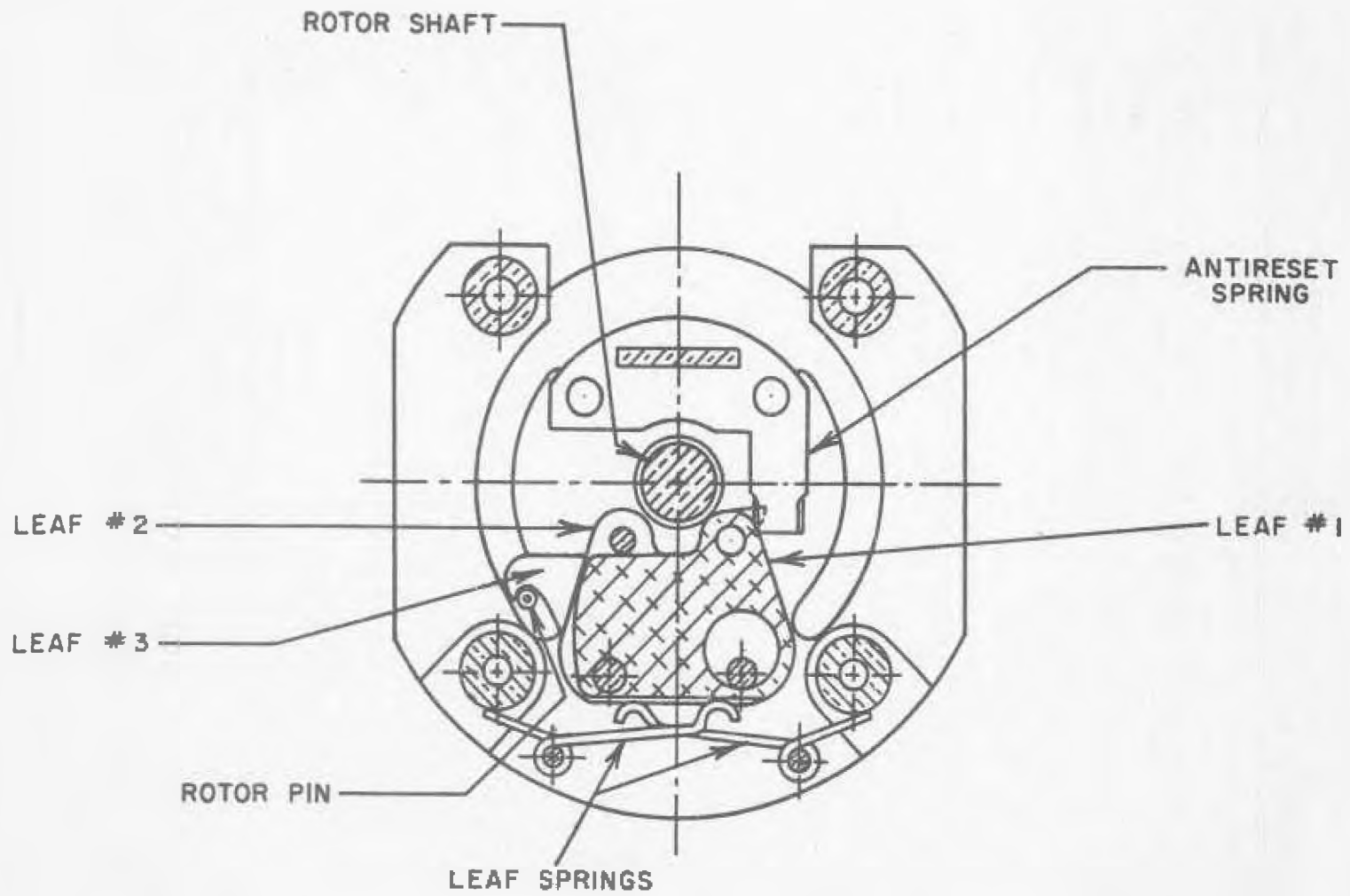

Figure 2. Sequential leaf setback release mechanism.

(2) The static rotor arming time was increased from about 9 msec to about 18 to 25 msec by increasing rotor travel from 90 to 270 deg. This was believed adequate to meet the arming-delay requirements for all HEAT shell except the 700-fps M371, in which the fuze arms in approximately 17 to 20 ft.

(3) The angular travel of each leaf on the setback arming system was increased to provide greater safety in drop and fouled-parachute tests.

(4) The maximum acceptable centrifuge arming acceleration was decreased from 4000 to 3400 g.¹

Although the M530 fuze did not meet the arming-distance requirement for the M371 shell, the fuze was in many functional aspects distinctly superior to the M509 type. Therefore, because of the urgent need for the M371 weapon, the arming-delay requirement was waived, and the M530 was standardized for use in this round² during 1958.

3. REQUIREMENTS ESTABLISHED FOR T278E8 FUZE

3.1 General Design Considerations

The developmental program for the T278E8 fuze was authorized by Picatinny Arsenal in 1959.³ The objective was to modify the M530 design (fig. 1) to provide sufficient delayed arming time to meet the 30-ft minimum arming distance specified for the M371 shell. At the initiation of this program, it was considered that the T278E8 might be applicable in all HEAT-series shell of the 76- to 120-mm range (table I). Such a universal use, however, would necessitate relaxation of the upper limit of permissible arming delay in the high-velocity shell, since a fuze providing 30 to 50 ft delayed arming in the 700-fps M371 shell would be expected to arm in about 170 to 300 ft in shell with 4000-fps muzzle velocity. The advantages of interchangeability, however, were believed sufficient to override the shortcoming. But during the development program, it was determined that this fuze, as well as its prototype (the M530), would not arm reliably in ammunition sustaining drag deceleration greater than about 20 g (sect 5.1.8). The use of these fuzes would therefore be limited to the first three items in table I. The M509-type fuze is the only PIBD fuze that is presently applicable for such high-velocity high-drag shell as the T180, T153, T384, and T300.

¹J. Miscampbell, DOFL Report No. TR-528, "Testing and Modification of Fuze, PIBD, T278E7 for PAT Program," 15 Dec 1957.

²OTCM 36849, dtd 28 Aug 1958.

³Ltr, PA to DOFL, dtd 1 June 1959, Subject: "Fuze, PIBD, T278E8, Project TW-425 (U)."

Table I. HEAT Shell Using PIBD Fuzes

Shell	Caliber (mm)	Max muzzle velocity(approx) (fps)	Max drag in flight (approx) (g)	Peak setback(approx) (g)
M371	90	800	2	7500
M344A1	106	1700	10	8000
XM452	120	1800	12	9000
T180(M496)	76	3700	42	41,000
T153(M469)	120	3900	33	29,000
T384(M456)	105	4000	36	36,000
T300(M431)	90	4100	53	43,000

3.2 Arming Delay Requirements

The minimum 30-ft arming distance for the -E8 fuze was specified by Picatinny Arsenal (ltr dtd 1 June 1959), but no maximum arming distance was formally stated in the program. A 50-ft upper limit, tentatively agreed upon by HDL and Picatinny Arsenal, was to be used unless some other distance was made mandatory later.

The normal muzzle velocity of the M371 shell is about 700 fps, varying from about 600 fps at -40° to about 800 fps at $+160^{\circ}\text{F}$. This velocity range requires that the minimum arming delay be about 50 msec. The initial fuze designs were, therefore, intended to provide this minimum static rotor delay time. But limited field tests with the M371 shell indicated that the fuzes provided somewhat greater arming distance than would be predicted from the static rotor arming time. Therefore, 40 msec was adopted as the minimum acceptable static arming time, pending results from field testing. However, since no additional M371 shell could be obtained for more than a year, it was necessary to freeze the design and manufacture fuzes for remaining ED/ET phases on the basis of the limited test data then available. The acceptable range of static rotor arming time used in this manufacture was 40 to 65 msec, which was later determined to be entirely satisfactory.

3.3 Sensitivity

A possible method of reducing effectiveness of HEAT ammunition is the use of a thin material (skirting armor) in front of the target. The purpose of this material is to initiate (or damage) the fuze at a distance sufficiently removed from the armor to prevent penetration by the jet.

To minimize the possibility of fuze initiation by a shell passing through brush, foliage, or skirting armor, a maximum sensitivity requirement was imposed on the fuze graze element. This requirement specified that the graze element shall not be initiated when the shell impacts a plywood target 1/4 in. thick. (The graze element is then required to function properly on impact with an armor plate placed behind the plywood target.) It was recognized, of course, that the use of a skirting armor requires that the round be made insensitive to normal piezoelectric initiation upon impacting the plywood target. This sensitivity is controlled by the design of the shell nose; therefore, it is not a function of the fuze design.

In all other respects, performance requirements for the T278E8 and the M530 fuzes are identical, as detailed in TL-PD-56.¹

4. T278E8 DEVELOPMENTAL HISTORY

4.1 General Design Description

The T278E8 fuze (fig. 1) consists of three major subassemblies—(1) a release (arming) mechanism and rotor assembly, (2) a rotor housing assembly, and (3) an aluminum shield assembly. An exploded view of these subassemblies and their components is shown in figure 3; the design layout is diagrammed in figure 4.

The release mechanism and rotor assembly includes a sequential-leaf setback release mechanism, a spring-driven brass rotor, and an arming delay mechanism. The rotor housing assembly includes a graze-initiation mechanism (fig. 4, 5) and part of the fuze electrical circuit (fig. 6). The aluminum shield (shown in frontispiece) provides for detonator safety, protects the mechanism from contamination with foreign matter, and houses the tetryl lead and booster pellet in the forward end of the fuze.

The fuze operates on the same principle as that described in section 2 for the M509 and M530. As stated, the only essential difference is that the -E8 model incorporates the longer delayed arming feature.

4.2 Design Modifications

During the T278E8 development, five design modifications were tested. In each instance, effort was made to minimize the extent of modification to the M530 basic fuze by employing a mechanical rotor delay device.

4.2.1 Tracked Rotor Design

The first effort utilized the tracked rotor design shown in figure 7. The fuze rotor was fabricated with a track in the

¹ Purchase Description for "Fuze, PIBD, T278E7," TL-PD-56, dtd Apr 1959,

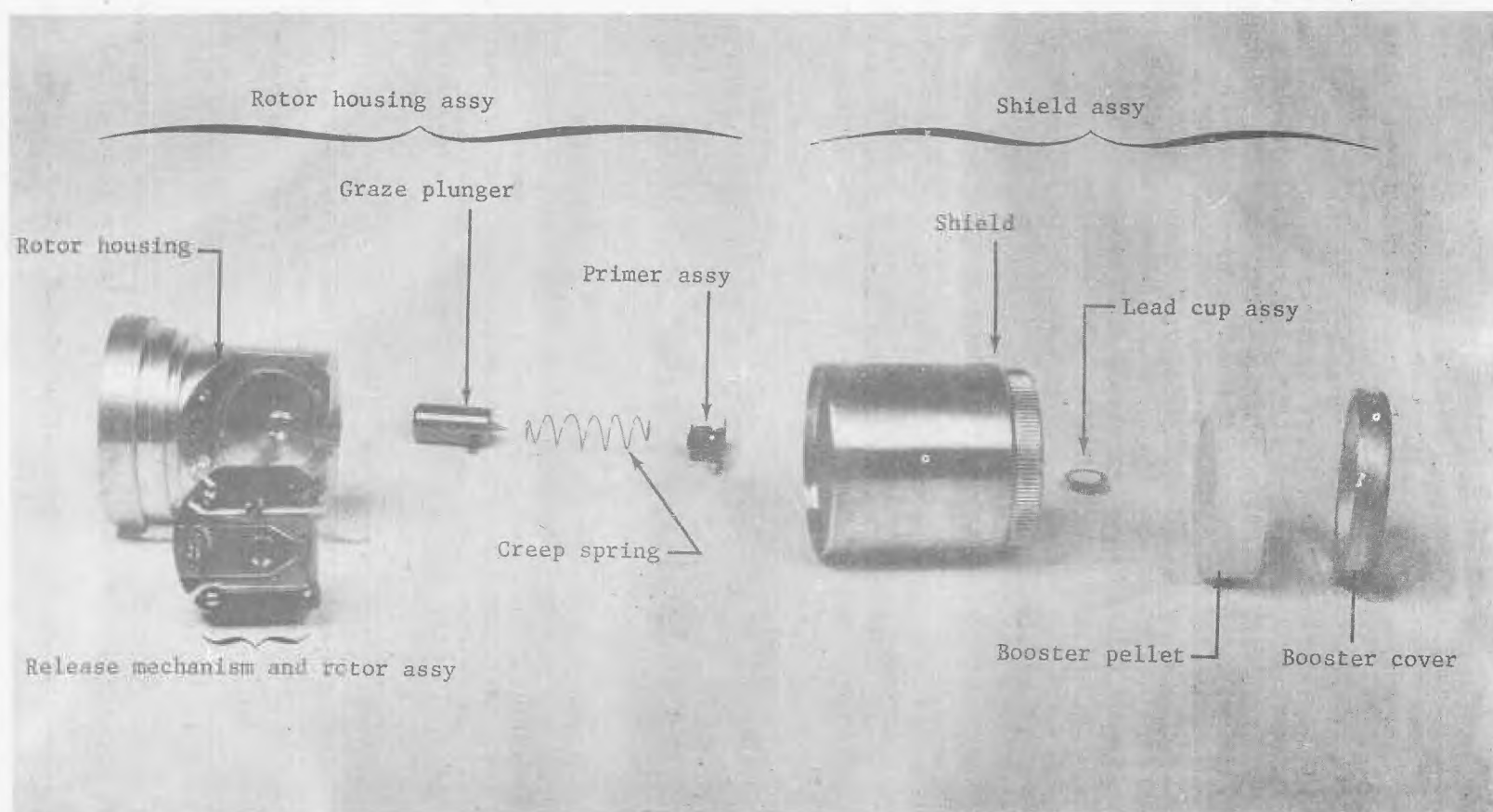

1126-62

Figure 3. Exploded view of T278E8 fuze.

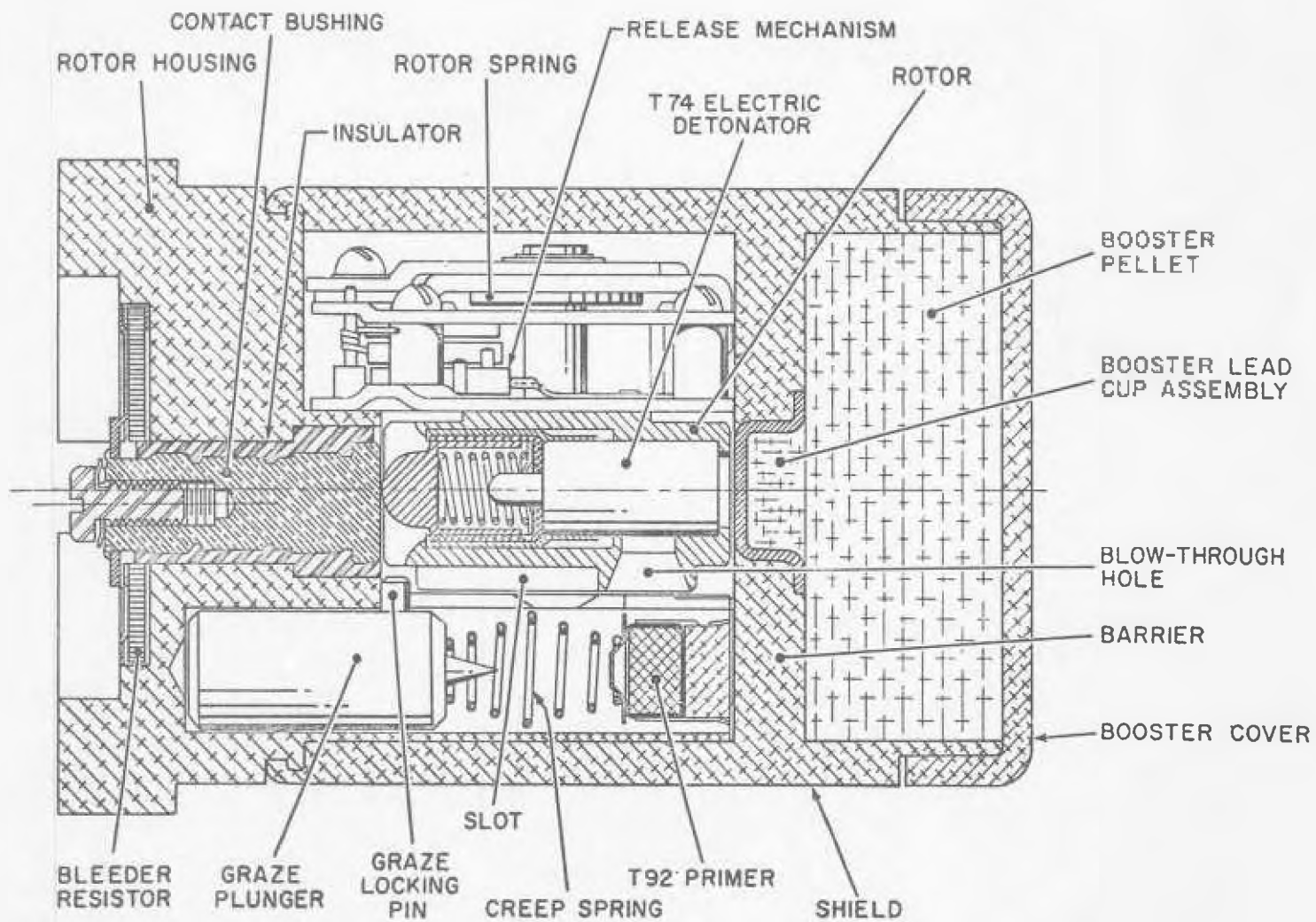

Figure 4. Line drawing of T278E8 fuze (armed).

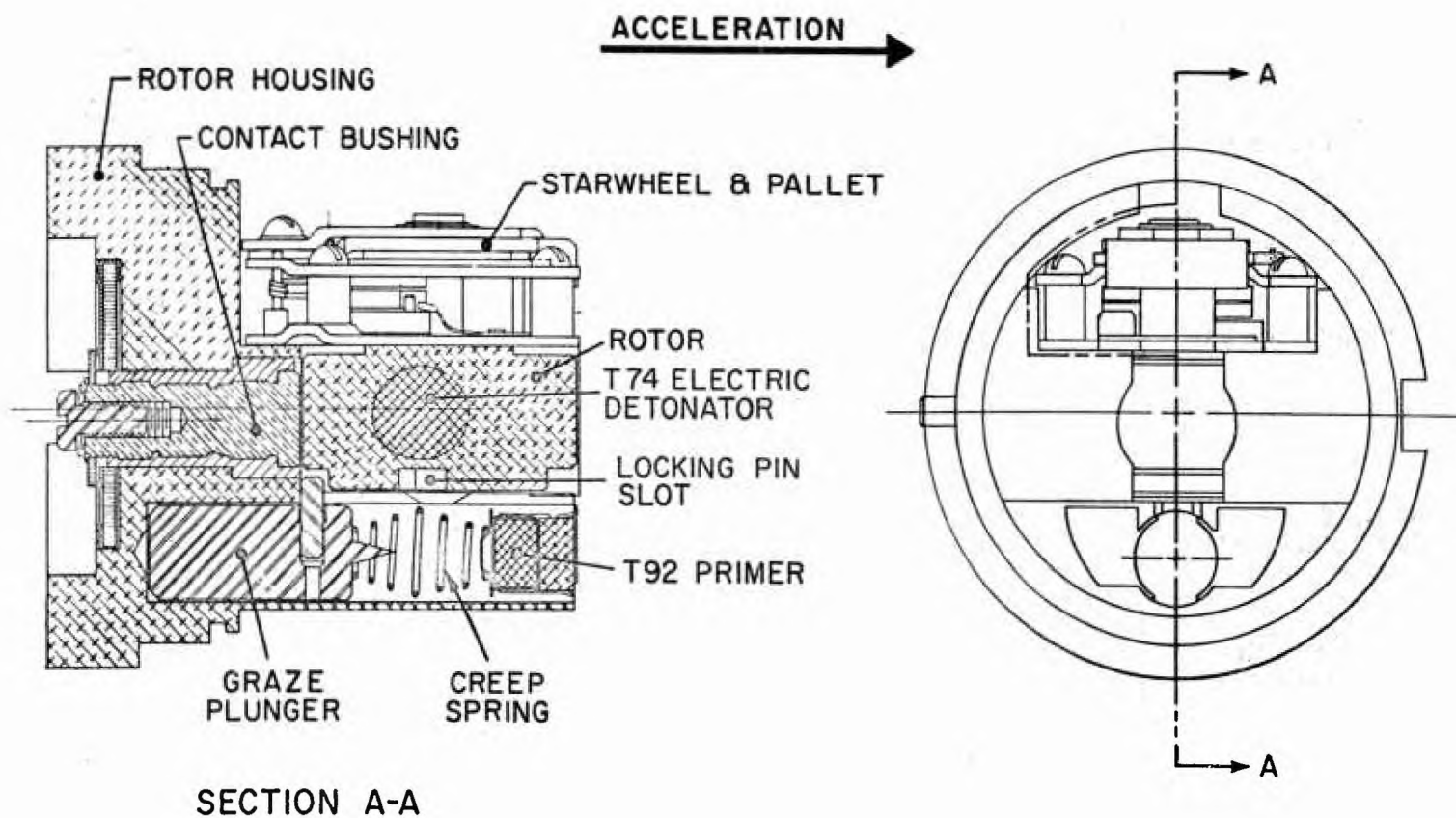

Figure 5. Line drawing of rotor housing release assembly (unarmed).

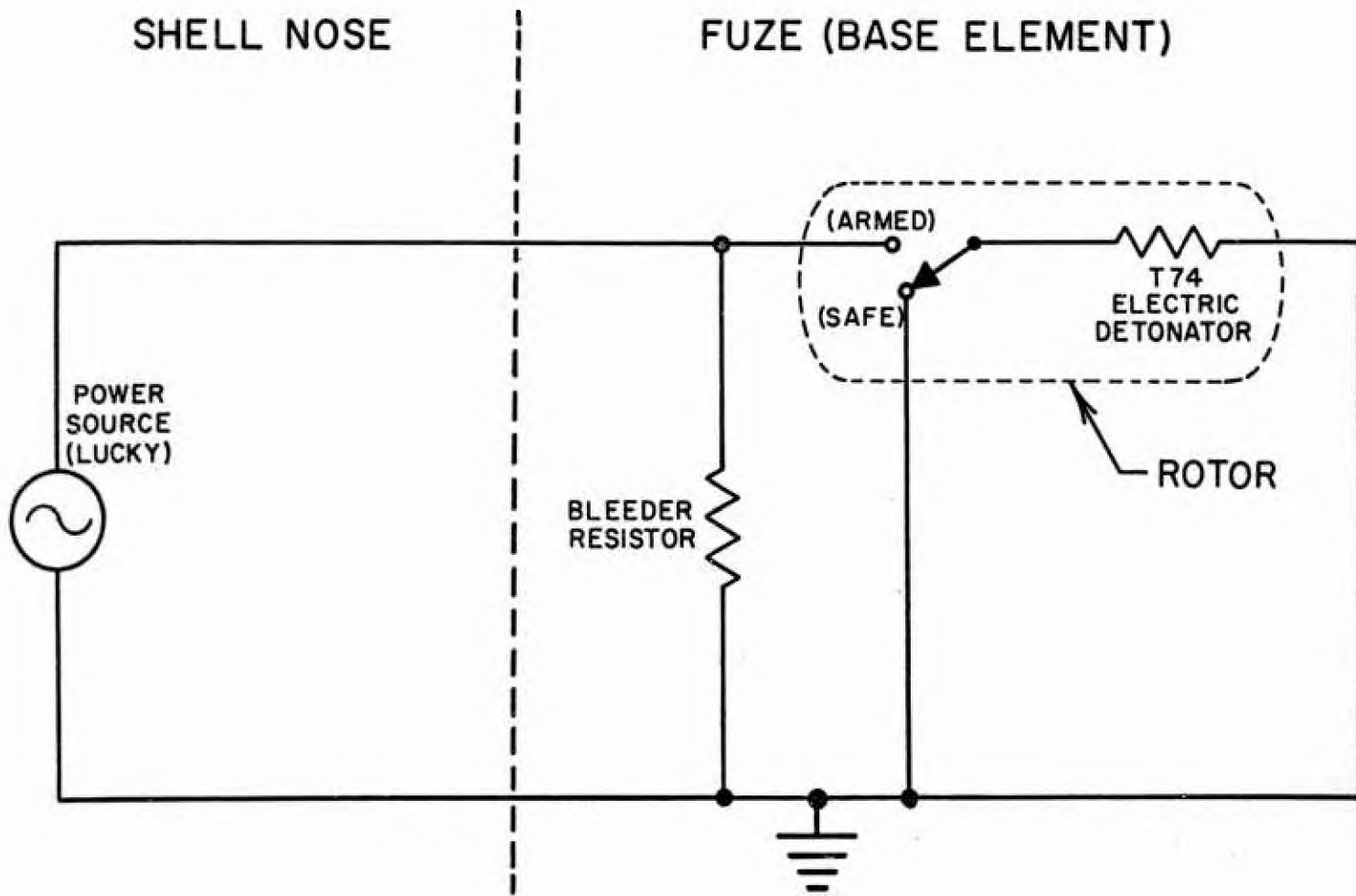
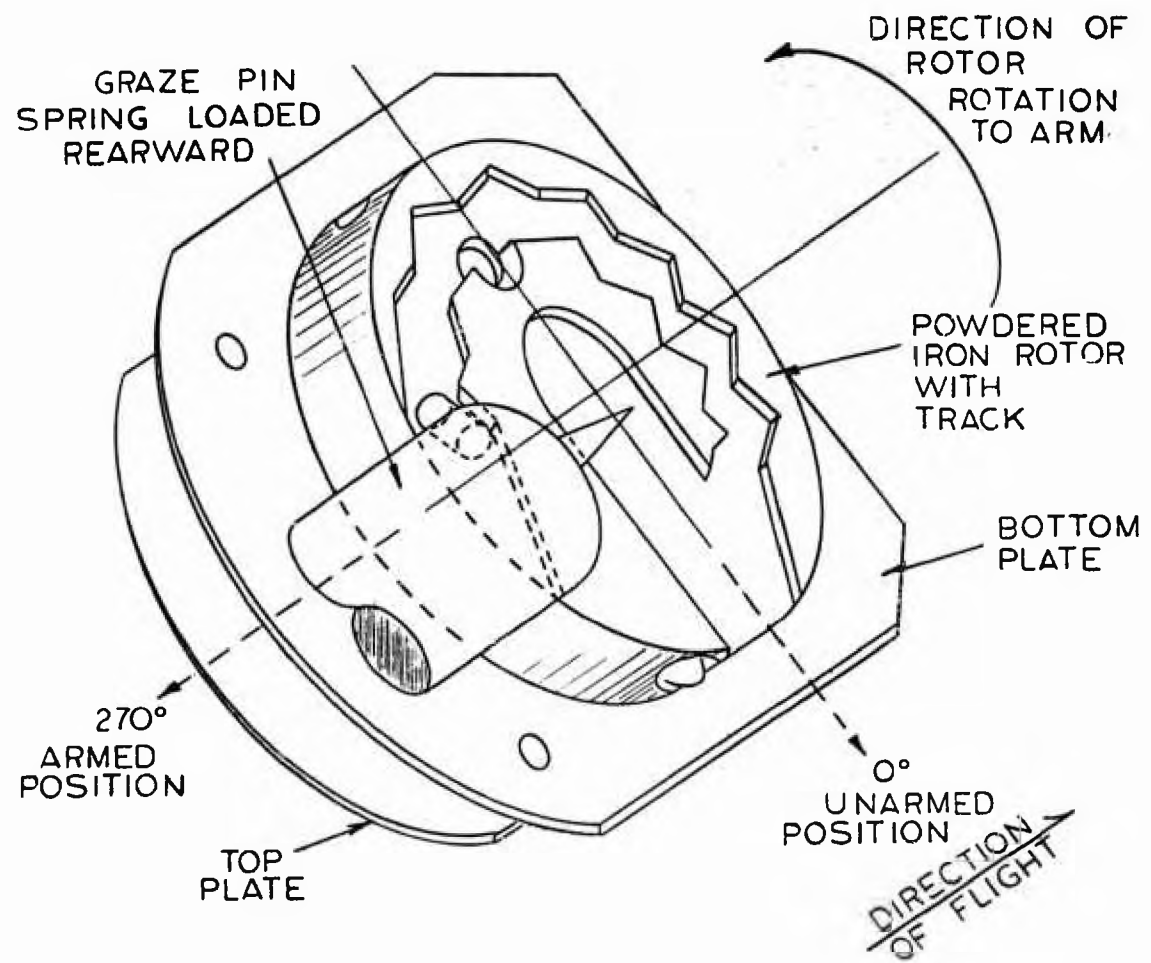

Figure 6. Circuit diagram of T278E8 fuze and shell assembly.



ROTOR SHOWN IN SAFE POSITION

Figure 7. Diagram showing tracked rotor design (bottom view).

flat face adjacent to the graze plunger. The contour of this track was similar to the tooth form of a starwheel. The locking pin projecting from the graze plunger was constrained to move in this zig-zag track as the rotor turned toward the armed position. This constraint caused the plunger to oscillate longitudinally in its cavity, thereby limiting the angular velocity of the rotor and increasing the rotor arming time.

Although this fuze design was considered desirable because of its extreme simplicity, much difficulty was encountered in attempting to attain consistent delay times from the crude escape-ment; in addition, the static arming time was marginally low. The design was believed sufficiently promising, however, to subject it to a firing test. Of five fuzes fired in a function-on-arming (FOA) test in the M371 shell, one failed to arm (sect 5.1.2).

Subsequent laboratory tests disclosed that setback could cause the graze plunger pin to deform the wall of the track and prevent the rotor from turning. Attempts to alleviate this condition by fabricating the rotor from sintered steel instead of brass were ineffective. It was, therefore, necessary to eliminate the initial portion of the track wall, thus reducing the arming time even further. After it appeared that this design would not provide the required performance without major modification to the basic fuze, the tracked-rotor principle was abandoned.

4.2.2 Ratchet Delay Design

This delay design included a ratchet wheel fixed to the rotor shaft of the M530 fuze, above the rotor torsion spring. A flat spring, fabricated from 0.003-in.-thick nickel alloy, was mounted on the front bearing plate of the fuze. Increased rotor arming time was provided by engagement between the ratchet wheel and spring as the rotor turned toward the armed position.

As in the previous design, the static rotor delay provided by this design was marginal. Also, it was very difficult to maintain sufficient control of the engagement between the ratchet and spring to prevent wide variation in delay time or complete arming failure. This problem was particularly noticeable after the fuze had been subjected to simulated firing tests in the air gun. After two of five ratchet units failed to arm in an FOA test (sect 5.1.2), the design was abandoned.

4.2.3 Starwheel and Pallet Delay

This design (shown in fig. 8) included a 40-tooth starwheel fixed to the rotor shaft of the M530 fuze, above the rotor spring and a pallet mass pivoted on the front bearing plate of the fuze.

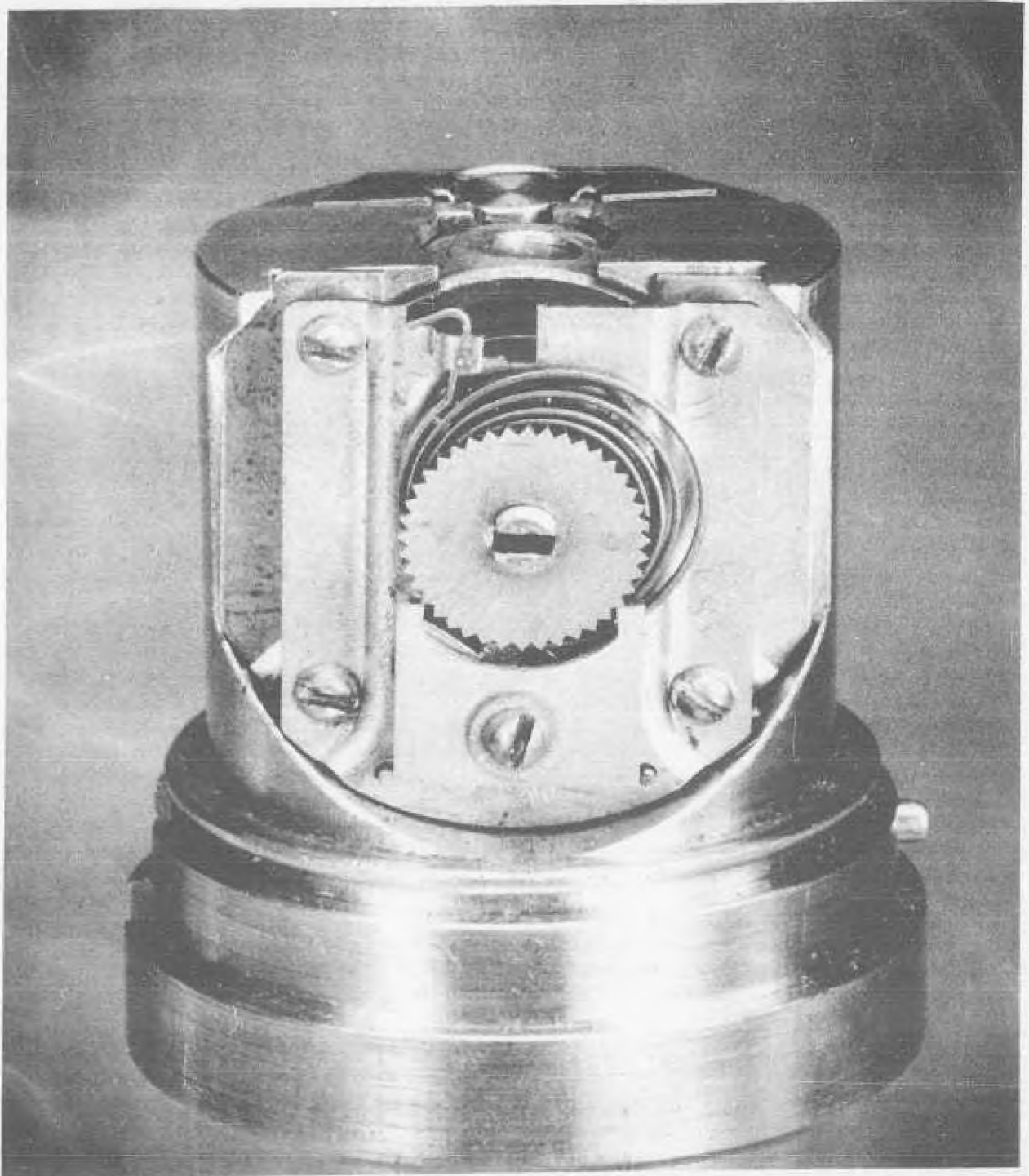

1981-61
Figure 8. Starwheel and pallet design.

Static timing tests indicated that this escapement was not capable of providing sufficient delay time to meet the minimum specified arming delay. Also, the delay time was erratic, because clearance between the rotor shaft and the holes in the bearing plates permitted excessive movement of the starwheel, relative to the pallet. The design was therefore modified as shown in figure 9.

4.2.4 Modified Starwheel and Pallet Delay

This design (fig. 9) included the following:

- (1) A 36-tooth gear fixed to the rotor shaft (close tolerances were placed on the rotor shaft and bearing plate holes to limit movement of the gear);
- (2) A 12-tooth pinion mating with this gear, which was mounted on a shaft pivoted in a third bearing plate fixed to the front bearing plate of the M530 fuze;
- (3) A 22-tooth starwheel mounted on the same shaft as the pinion; and
- (4) A pallet pivoted on the added outer bearing plate to mate with the starwheel. The outer bearing-plate assembly was fixed to the M530 by holding screws.

To provide space for the additional components, the following modifications were required in the basic M530 fuze design: (1) the assembly required a relief in the rotor housing for the added bearing plate; (2) the height of the rotor spring was reduced from 0.065 to 0.030 in. to keep within the existing fuze dimensions. To maintain the necessary rotor torque, the thickness of the rotor spring stock was increased from 0.0095 to 0.0135 in.

Prototype models of this delay design provided adequate rotor arming time (approx 50 to 70 msec) in static laboratory tests. In air-gun tests, the mechanism was subjected to over 40,000 g without failure. Ten units were then prepared for FOA tests in the M344A1 shell. During these tests, indication of arming was obtained in only six of ten fuzes, and the delay distances were not consistent (sect 5.1.3). The design was therefore terminated in favor of the fuze design described in the next section, which was tested at the same time with appreciably better results.

4.2.5 Mechanical Escapement Delay—Zenith Design

A mechanical escapement delay was designed by the Zenith Radio Corp (fig. 1,4) under HDL contract. This design incorporated a starwheel and pallet assembly that was intended to overcome the deficiencies encountered in the earlier designs described. First, it

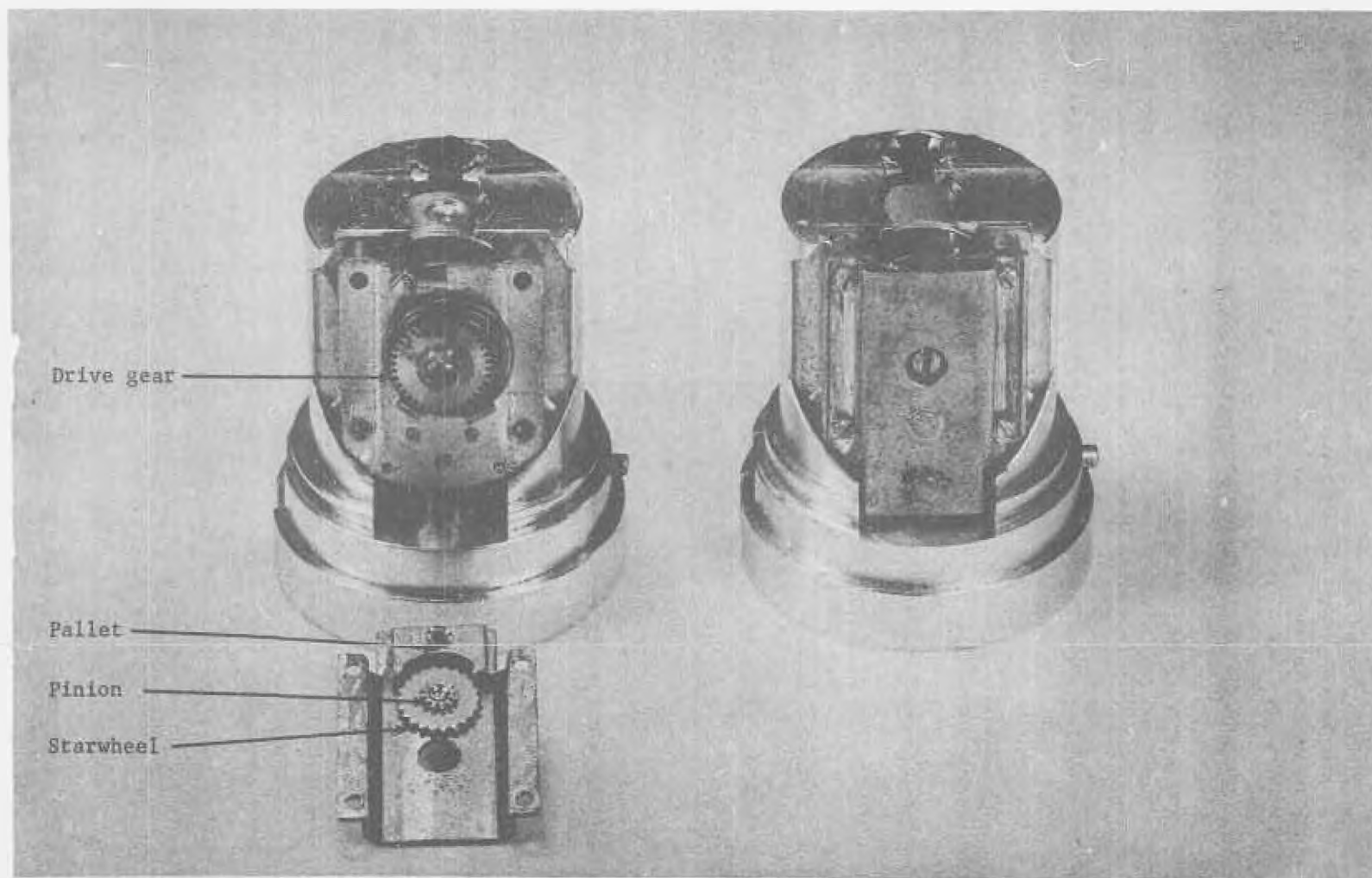

2428-60

Figure 9. Modified starwheel and pallet design.

was apparent that for relatively close control over the range of arming time, the center distance between the starwheel and pallet would have to be rigidly maintained. This was accomplished by mounting the starwheel and pallet on the same plate—an added part mounted in front of the existing front bearing plate.

It was desired to attain the required arming delay without the use of a gear reduction step, which would be undesirable because of space limitations. It was therefore necessary to make the pallet moment of inertia very large. This was accomplished by designing a pallet that passes around the starwheel and extends beyond it to the top of the front bearing plate. The pallet was then formed over this plate to utilize some space available between the front and rear bearing plates. In this configuration, the pallet CG is relatively far from the pivot point at the lower end of the front bearing plate. Thus, the rotational inertia is maximized.

The starwheel was fabricated integral with a hollow stud, which was journaled into a hole in the outboard bearing plate and crimped over a washer. This assembly controls the location of the starwheel closely, and still permits it to turn freely in the bearing plate.

Parallel flat faces were milled on the end of the rotor shaft, so that the shaft could be keyed loosely into a rectangular slot in the face of the starwheel to provide the driving torque. This loose coupling prevents any small eccentricities in the rotor shaft from affecting operation of the starwheel and pallet.

The first two models of this design included 20-tooth starwheels and 0.035-in.-thick pallets fabricated from soft steel. The pressure angle was 45 deg. The static rotor arming times were 40 to 45 msec. One unit was subjected to an air-gun test of 25,000 g, after which the mechanism worked haltingly and tended to bind. Examination of the mechanism showed that the pallet had bent below the points of starwheel engagement (fig. 10a)

The soft steel pallets were then replaced with spring-steel pallets that had a greater web thickness in the area where bending occurs as shown in figure 10b. Both units operated properly after being subjected to successive air-gun tests of 10,000, 20,000, and 40,000 g.

On the basis of this performance, 15 identical units were fabricated, 10 of which were used in an FOA test in M344A1 shell (sect 5.1.4). This group of fuzes had a static rotor arming time ranging from 37 to 46 msec with an average of about 41 msec. Ten units were also fabricated and tested to determine if the static rotor arming time could be increased significantly by increasing the thickness of the pallet from 0.035 to 0.042 in., which is the maximum

(a) Original pallet configuration (soft steel)

(b) Pallet (spring steel) with increased stiffness in lower portion

(c) Final pallet design (brass) with formed-over section at top eliminated

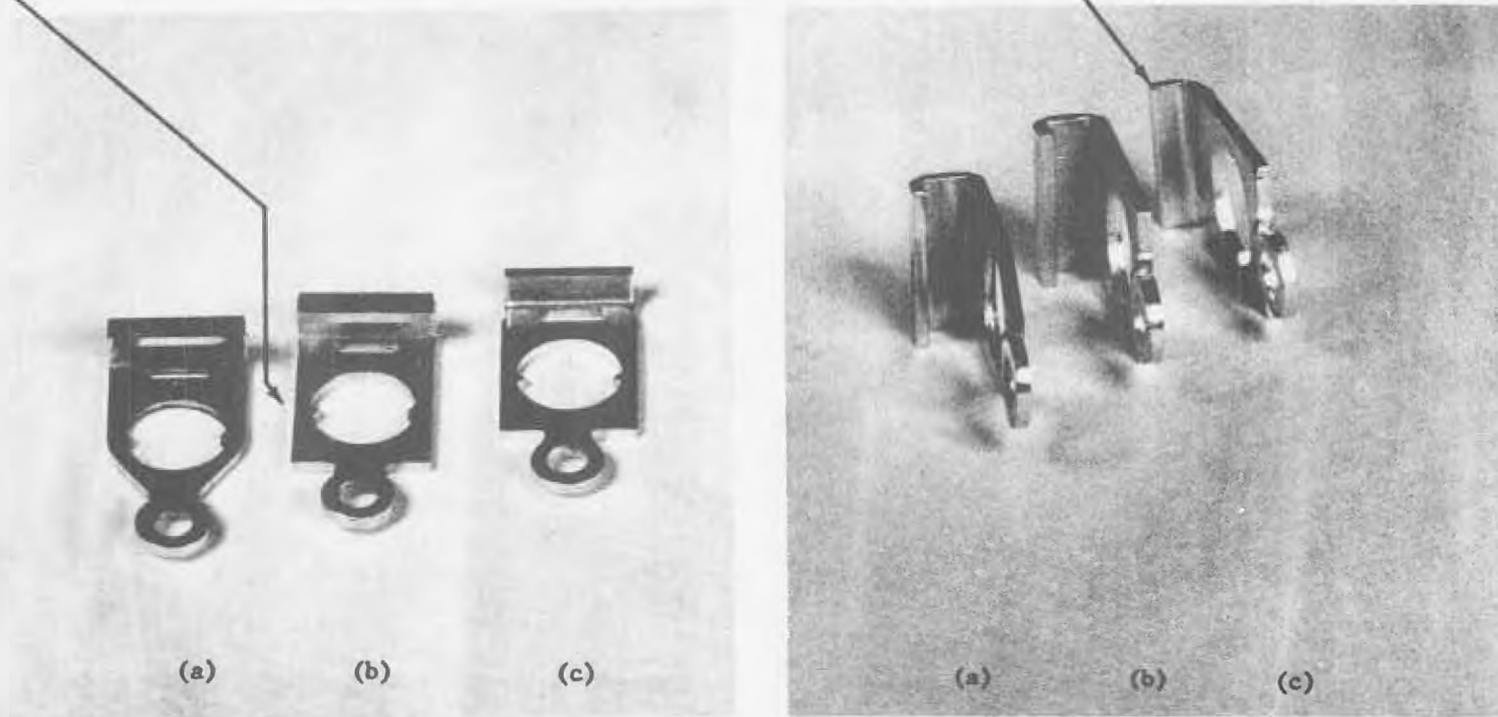

1131-62
Figure 10. Pallet designs tested during T278E8 development.

thickness that space permits. The average static arming time was about 43 msec. The shortest arming time, however, was about the same as that of the previous group.

Following laboratory and FOA tests, it was decided that the performance of this design was sufficiently promising to warrant a function test of the fuze in M371 ammunition. Thirty-five fuzes were constructed for field tests (sect 5.1.5 and 5.1.6). Thickness of the spring-steel pallet material was 0.038 in. Static rotor arming time ranged from about 40 to 65 msec, with an average of 44 msec. Field-test performance of this lot indicated that the design would meet all requirements except operation at -65°F . At this temperature, the rounds were duds either because of nonarming or because of excessively long arming delays. When no positive cause was determined for the -65°F failures, HDL requested that the lower operating temperature limit be changed from -65 to -40°F ; this change was subsequently authorized.¹ This test tended to confirm that a static rotor arming time of 40 msec was adequate to provide the required 30-ft delayed arming.

Following this test in the M371 shell, it was learned that no additional M371 ammunition would be available for an indefinite time. To minimize further delay in the program, developmental test firings were continued with the T300E56 shell.

Before manufacturing fuzes for this test phase, the necessary tooling was completed to assure uniformity of the pallet, since this part included a number of extremely close tolerances essential to proper operation of the timing mechanism. At this time, certain modifications, which were indicated necessary or desirable during laboratory tests, were added to the pallet design:

(1) The pressure angle of the leading edge on the pallet face was decreased to 40 deg to increase the rotor arming time slightly.

(2) The second 90-deg bend (at the top of the pallet and beyond it) was eliminated, since the reduced pressure angle sufficiently lengthened the static rotor arming time. This modification (fig. 10c), facilitates manufacture and reduces cost of the part.

¹Ltr from OCO (ORDTW-CVS) to OSWAC, dtd 20 Feb 1961, Test Program Request No. ASX-T278-37.

(3) The pallets were made of hard cartridge brass. This material was adopted rather than spring steel because it is easier to machine and requires no heat treatment.

Forty fuzes were then manufactured with static rotor arming time ranging from 41 to 55 msec. Performance in the T300E56 shell was unsatisfactory (sect 5.1.7). Investigations disclosed that the T278E8 fuze, as well as the M530 fuze, cannot be used in shell whose drag deceleration exceeds about 20 g. Deceleration of the T300E56 shell within the normal arming range is greater than 50 g. Considerable R&D work would have been required to correct this limitation; therefore, since the T278E8 was intended specifically for use in the M371 round, no attempt was made to alter the fuze design in this program. Accordingly, manufacture of fuzes for the remaining ED/ET phases was completed, with static rotor arming times of 40 to 65 msec (fig. 11).

4.2.6 Assembly of Shield to Rotor Housing

The shield of the M530 fuze is assembled to the rotor housing by roll crimping a thinned section into a groove of the housing, which sometimes breaks the rolled portion. Furthermore, the roll crimped fuze cannot be disassembled without destroying the shield and booster assembly. During the -E8 development, a knurl press fit assembly was used, the knurl replacing the crimping groove on the rotor housing (fig. 12). Preliminary models of this design performed satisfactorily in MIL-STD tests, and it appeared that this assembly method would be more suitable for production than the present M530 assembly technique. Therefore, all T278E8 fuzes fabricated for engineering tests incorporated the knurl assembly. Manufacturing experience, however, indicated that this assembly method was less desirable than previously considered. Very close tolerance control was required to maintain a uniform press fit; also, the shield was sometimes bulged when pressed on to the rotor housing so that assembling of fuze in the cavity was a problem. The roll crimp assembly method is, therefore, indicated on the T278E8 final drawings (app A).

5. PERFORMANCE

5.1 Engineering Design Tests

5.1.1 Arming Distance of Fuze-Shell Combination

The arming distance was determined in FOA tests of the T278E8 fuze by utilizing a 45-v battery and a 0.25- μ f capacitor pack potted with epoxy resin in the shaped-charge cone. One side of the circuit was grounded to the cone by silver soldering the lead. The other lead was connected to the fuze terminal. The fuzes contained all explosive components; the shell were completely inert except for a small pyrotechnic spotting charge placed in front of the booster.

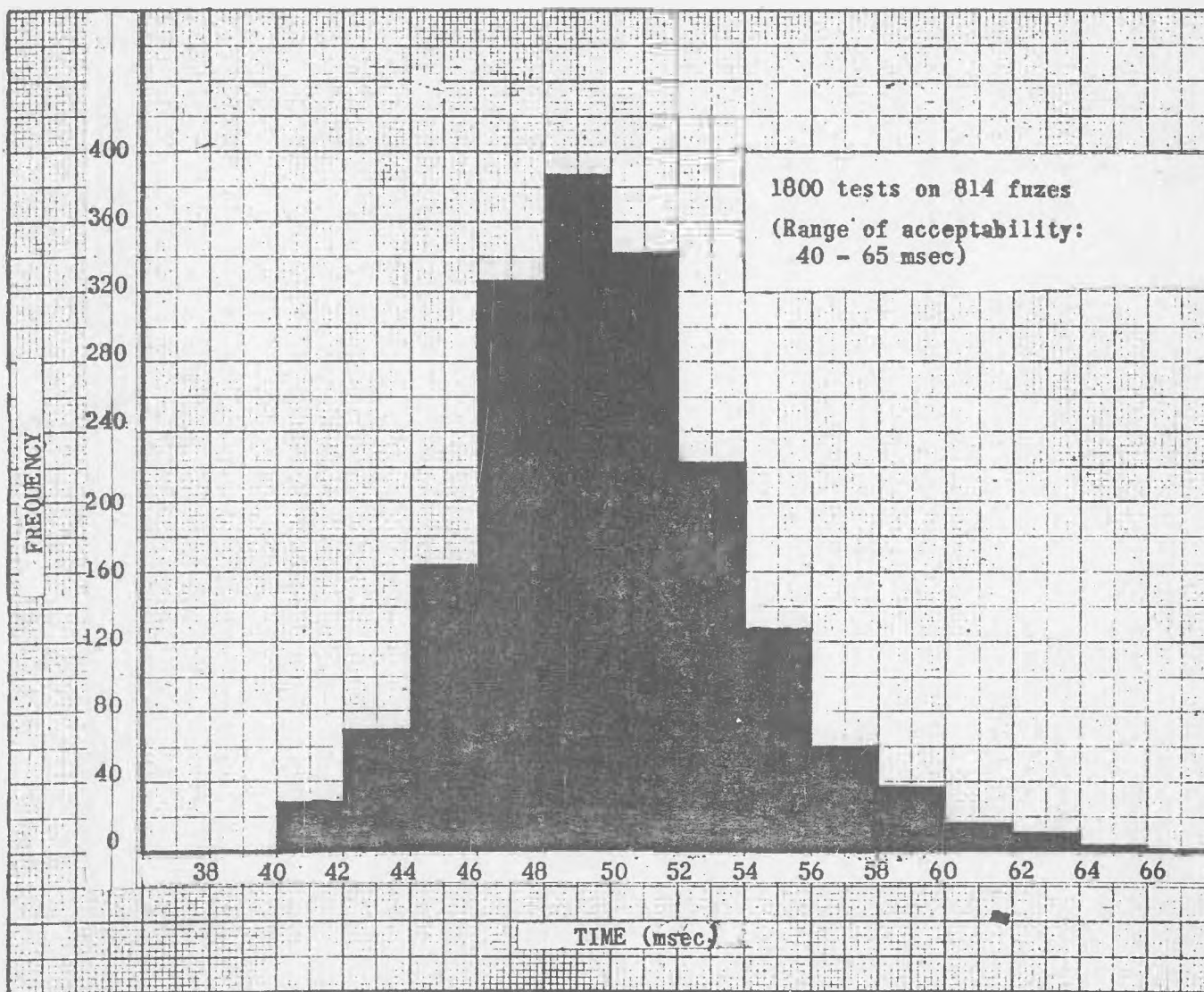
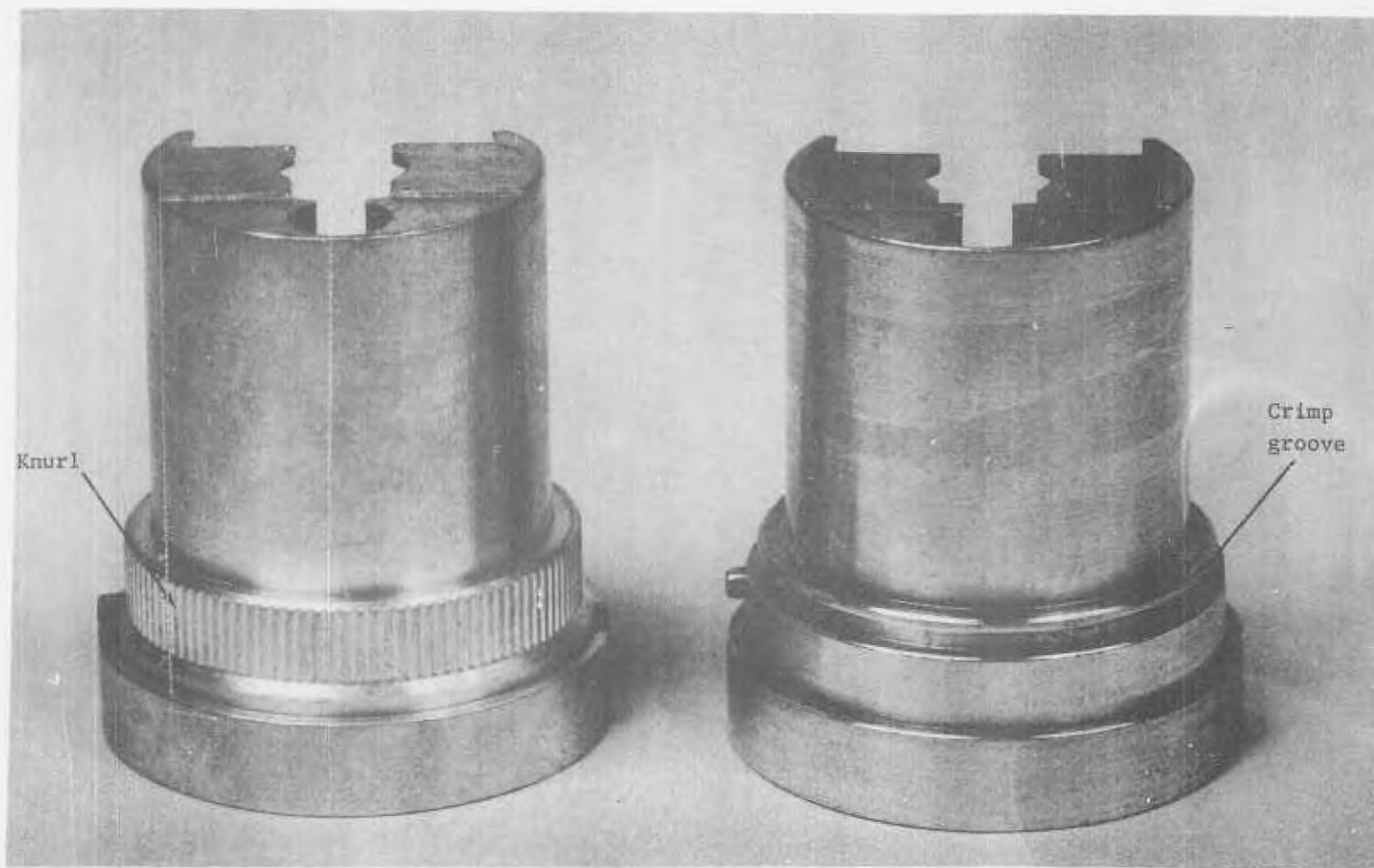

Figure 11. Graph showing frequency distribution of static rotor arming time of T278E8.



1125-62
Figure 12. Rotor housings designed for knurl press assembly and 360-deg crimp assembly of shield.

The total weight of the inert shell and its CG were adjusted to those of an HE-loaded shell. When the rotor armed, the circuit was completed from the battery-capacitor pack to the detonator and the fuze was initiated. The flash of the spotting charge was photographed against a calibrated background, providing an accurate determination of arming distance.

5.1.2 Arming Distance of Tracked Rotor and Ratchet and Spring Designs

Two designs were subjected to FOA tests at Aberdeen Proving Ground (APG), using the battery-capacitor packs in M371 shell. The following arming distances were obtained:

<u>Tracked Rotor</u> (ft)	<u>Ratchet and Spring</u> (ft)
34	no function
34	no function
49	34
no function	34
36	30

5.1.3 Modified Starwheel and Pallet Delay

The modified starwheel and pallet delay was subjected to FOA tests in the M344A1 shell, since M371 shells were not available. Muzzle velocity of the M344A1 is about 1600 to 1650 fps at 70°F; the arming distance obtained in this shell must be corrected by the shell velocity ratio, approximately 700/1600, to determine the approximate arming distance that would be attained in the M371. (This correction may not be completely valid, since the arming delay of this type fuze is affected by drag deceleration of the shell. However, centrifuge timing tests have indicated that variation in delay caused by drag is not a major factor within the range experienced by these two shells, see fig. 13, table I).

The tests were conducted at the HDL Test Area. Shell velocity and arming distance were determined by using a Fastax camera to provide a basis for estimating the expected arming delay in the M371 shell. Static rotor arming time ranged from 52 to 68 msec. The following results were obtained:

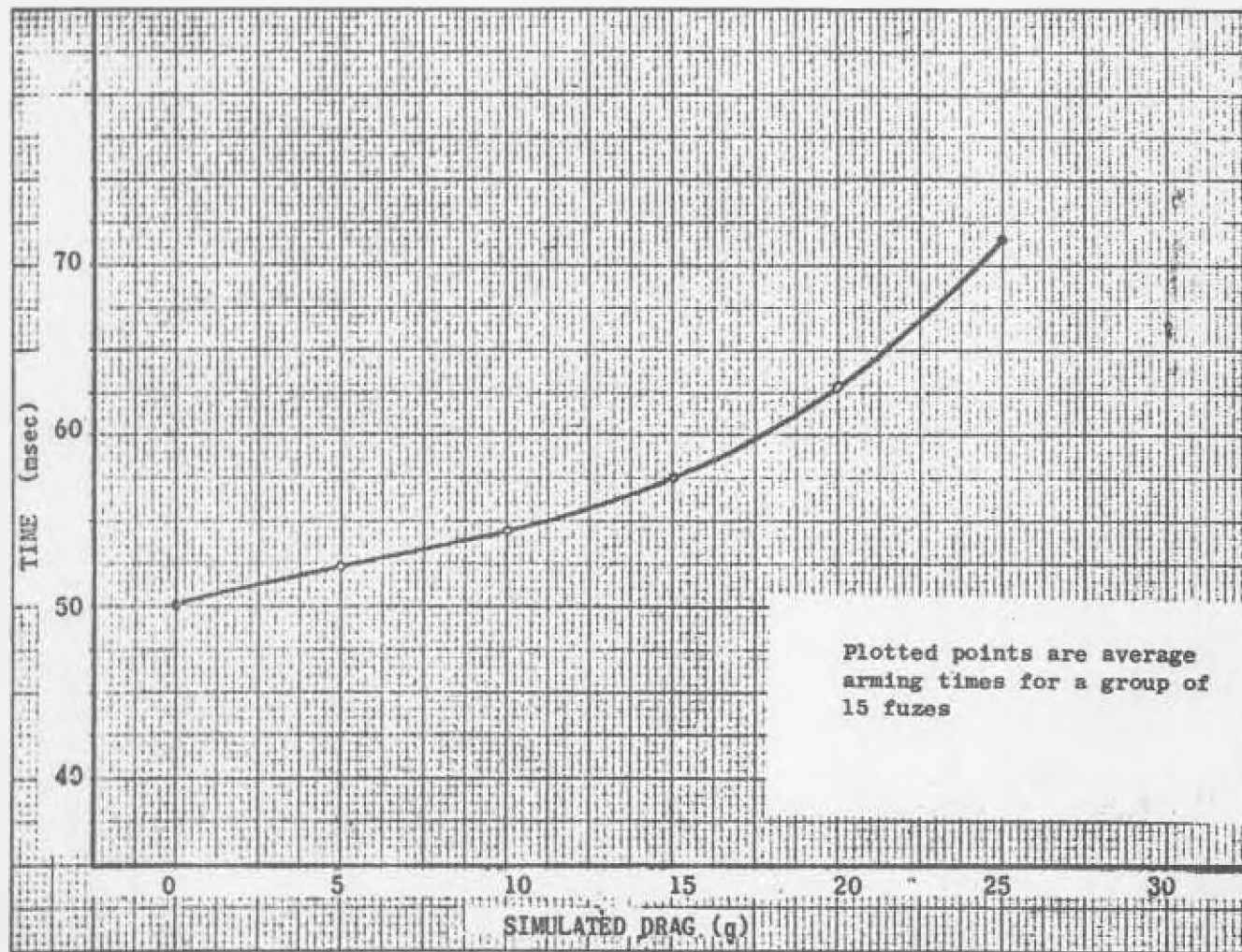

Figure 13. Drag deceleration effect (simulated by centrifuge) on T278E8 rotor arming time.

Arming distance in M344A1 shell (ft)	Calculated arming distance in M371 shell (ft)
90	39
111	49
132	58
138	60
143	63
148	65

(Four fuzes failed to function)

5.1.4 Zenith Escapement Design

Ten fuzes using the Zenith escapement design were also tested at HDL Test Area in M344A1 shell with the following results:

Arming distance in M344A1 shell (ft)	Calculated arming distance in M371 shell (ft)
72	32
76	33
78	34
78	34
78	34
83	36
83	36
83	36
94	41

(The one remaining shell was observed to function within the same arming range as those recorded; exact arming distance was not obtained because of camera failure.)

The static rotor arming time of these fuzes ranged from 37 to 46 msec.

These test results indicate that the Zenith design is more reliable than the other systems tested; also, it appears to provide more closely controlled range of arming delay within the

specified arming-distance limits. The Zenith design, furthermore, is less complex and hence less costly to manufacture. For these reasons, it was adopted as the basic design of the T278E8 fuze. The final fuze design, as manufactured for engineering tests, differs only in minor modifications of the pallet as described in section 4.2.5.

5.1.5 Arming Distance Tests in M371 Shell at APG

Using the Zenith fuze design, a firing test was conducted at APG on 16 Nov 1960 to evaluate the fuze performance in the M371 shell. (This was the only ED firing test using the -E8 design with M371 shell during the development program. No additional M371 shell were available until 1962.) Twenty rounds were fired to test arming delay and impact function on armor plate target.. Ten rounds were fired to test fuze impact sensitivity.

Table II. Arming Distance Test In M371
(piezoelectric initiation by armor plate target)

Rounds fired	Conditioned temp(^o F)	Distance to target (ft)	Test results
3	-65	45	All duds
3	-40	45	All proper functions
4	+70	45	All proper functions
10	-40	29	All duds

These results indicate that the fuzes provided the required minimum arming distance in the M371 shell at temperatures above -40^oF. The only deficiency revealed in this test was in the three rounds that were conditioned at -65^oF. Based on a recommendation by Picatinny Arsenal, a lower temperature of -40^oF for fuze operation was later authorized by OCO. Additional laboratory data indicated that these three fuzes probably dudded at -65^oF because of slow arming rather than nonarming (fig.14). These test results also indicate that the arming distance attained in firing tests was greater than would be predicted from the static rotor arming time (sect 3.2). The average static rotor arming time for this group of fuzes, about 44 msec, would be expected to produce several armed fuzes among the 10 fired at 29-ft range. Since the average muzzle velocity for the shell was slightly over 600 fps, an average arming distance of about 26 ft would be predicted.

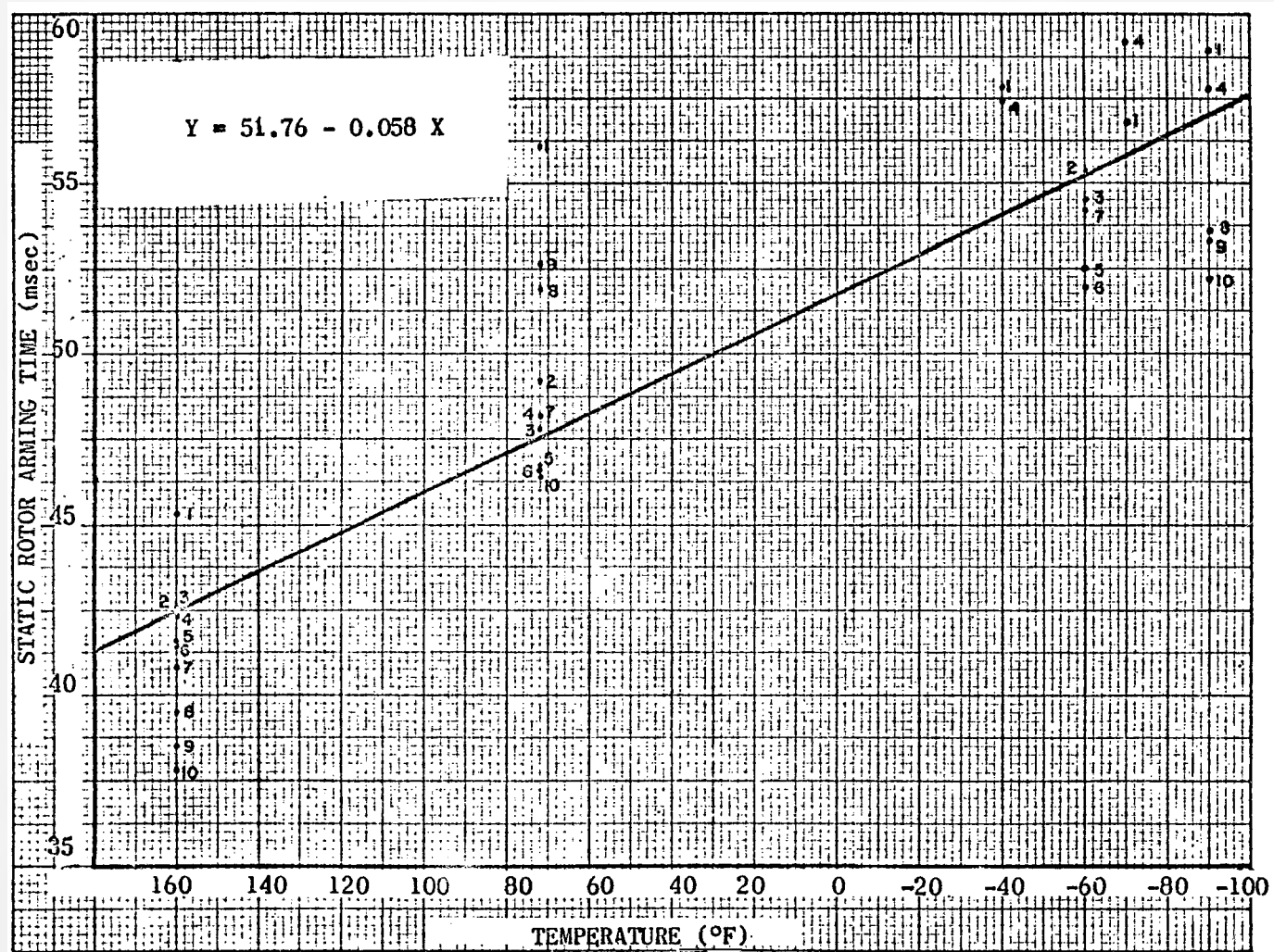

Figure 14. Static rotor arming time versus temperature for T278E8 fuze.

5.1.6 Graze Element Sensitivity Test

Ten shell, with piezoelectric elements removed, were conditioned at 70°F, and fired against a 1/4-in. plywood target from a range of 300 ft. A 4-in. thick armor target was placed 8 ft beyond the plywood. This test arrangement was used to determine if the fuze graze system would pass the minimum sensitivity requirement described in section 3.3. All fuzes functioned properly—failed on plywood but functioned on armor plate.

5.1.7 Firing Test in T300E56 at APG

As noted previously, it was originally thought that the T278E8 fuze might be operable in all shell of the HEAT artillery series, even though a waiver by CONARC might be necessary for the maximum acceptable arming distance in the T300, T384, T180, and T153 shell. Since the T300E56 attained the highest acceleration and velocity in the HEAT series, a firing test with the T278E8 fuze was conducted at APG under ambient temperature conditions.¹ Of nine rounds fired for target function on armor, brick, and 1/4-in. plywood, at a range of 400 to 1000 ft, all were duds. Of five rounds fired for graze action, four were reported by an observer to have functioned on impact with earth at a range of about 800 ft; the remaining round was a dud.

5.1.8 Laboratory Investigation of Malfunction in T300E56 Shell

To determine the reason for malfunction of the fuze in the T300E56, laboratory tests were conducted to ascertain the arming characteristics of the -E8 fuze in an environment of high drag deceleration. (The T300E56 may experience over 50-g drag during the intended arming period.) In these tests, the fuze setback leaf arming system was armed, and the rotor was restrained in the safe position by a locking pin controlled by a solenoid. The assembly was then placed in a centrifuge and an acceleration simulating the drag was applied along the axis of the fuze. When a predetermined deceleration was attained, the rotor locking pin was extracted and the time required for the rotor to turn to the armed position was measured. These tests, conducted with the T278E8, M530, and M509E6 fuzes, conclusively established that the T278E8 and M530 fuzes cannot arm in the high-g deceleration environment experienced by high-velocity HEAT shell. The limit of deceleration under which these fuzes appear capable of operation without excessive increase in arming time is about 25 g (fig. 13). Above this limit, arming time becomes very erratic; and the rotor frequently fails to arm. The principal cause of failure is friction between rotor and cavity as the rotor moves forward and seats on the cavity under deceleration. (The rotor shaft bearings are deliberately made large enough to permit the rotor to seat in its cavity under setback. This is necessary to prevent bending of the rotor shaft during firing acceleration.) A contributing cause for

¹ Aberdeen Proving Ground DFS Firing Record No. P-66601, dtd 21 May 1961.

arming failure at high reverse g is friction exerted on the rotor by the graze weight through the graze-locking pin.

By contrast, the M509E6 fuze, which has a light aluminum rotor turning only 90 deg and no graze weight, is not affected by drag of less than about 80 g. This is far in excess of the deceleration experienced by any shell in the HEAT series.

The cause for the shell detonations attained in the graze test is not known. It is possible that the initial graze impact reduced shell velocity (hence, drag) sufficiently to permit the fuze to arm, and that fuze function actually occurred on a second graze impact. Also, it is possible that the shell could have deflagrated on graze impact.

5.1.9 MIL-STD Tests

Sixty-eight T278E8 fuzes passed the following MIL-STD tests:

<u>No. tested</u>	<u>Test</u>
15	Jolt, MIL-STD-300
15*	Jumble, MIL-STD-301
20**	40-ft Drop, MIL-STD-302
18	Transportation Vibration, MIL-STD-303
20	5-ft Drop, MIL-STD-358
15	Detonator Safety, MIL-STD-315

5.2 Engineering Tests (Conducted in 1962)

All engineering tests were conducted using M371 ammunition (lot IOP-SL-15) fired from an M67 gun.

It had been intended that a final engineering development test of 100 rounds would precede the engineering test. This was prevented, however, by the lack of ammunition. Since the ammunition for both tests became available at the same time and the fuzes were from a single lot, the tests were combined.

*These fuzes were jolt tested before subjection to jumble test.

**These fuzes were subjected to 5-ft drop tests before the 40-ft drops.

5.2.1 Armor Plate Impact Reliability Test

Sixty rounds (conditioned 20 each at +160°, +70° and -40°F) were fired to impact a vertical 5-in. armor-plate target 300 ft from the gun. Proper fuze performance was obtained in all rounds. Shell separation occurred in five at high temperature, but the rounds functioned by graze action on the target. One shell missed the target and the round functioned by graze action down range. The remaining rounds functioned by piezoelectric action on the target.

5.2.2 Arming Delay

The delayed arming feature was tested, using 120 rounds in accordance with MIL-STD-313. These rounds, 60 conditioned at +160°F and 60 at -40°F, were fired to impact a 5-in. vertical armor plate at various ranges. The function data, compiled by the DPS Analytical Lab at APG, indicate the following arming delay performance characteristics:

Table III. Arming Delay Test Results

Distance from muzzle (ft)		Percent armed	Limit of 90% confidence belt (ft)	
+160°F	-40°F		+160°F	-40°F
34.3	38.2	1	28.7 min	32.2 min
36.8	39.8	5	33.1 min	35.9 min
41.2	42.8	50	-	-
45.6	45.7	95	49.4 max	49.0 max
48.0	47.5	99	53.8 max	52.6 max

These data indicate that the fuze arming delay meets the 30- to 50-ft arming distance requirement. However, a larger sample size would be required to establish that the extremes of 90-percent confidence at the 1- and 99-percent function levels fall within these limits.

5.2.3 Graze Sensitivity

Since the graze-function mechanism of the T278E8 fuze is identical with that of the M530, the graze sensitivity function tests were conducted primarily for comparison—to demonstrate

that the arming mechanism modification did not degrade the graze-system performance. Forty rounds were tested for graze function on dirt and hard asphalt targets, as shown in the following table.

Table IV. Graze Sensitivity Test Results

Rounds fired	Temp (°F)	Impact surface	Range (ft)	Number functions first impact	Number functions subsequent impacts	Number duds
10	+160	Asphalt	300	10	0	0
10	+160	Dirt	425	10	0	0
10	-40	Asphalt	300	5	4	1
10	-40	Dirt	425	9	1	0

The T278E8 graze element performance compared favorably with that of the M530 in all cases where comparison data were available—there are no M530 graze test data for impact on asphalt at -40°F. A flat grazing impact with a very hard target at extreme cold temperatures is considered the most severe condition that might be imposed. Since nine of ten fuzes functioned on the first or subsequent impact under this severe test condition, the performance of the graze element is considered adequate.

5.2.4 Impact Sensitivity

The maximum sensitivity requirement for the M371 round was imposed to prevent fuze function on material that the round might be required to penetrate without function. The criterion established for this requirement is that the fuze must not function on 1/4-in. plywood placed normal to the line of flight of the projectile. To ascertain that a nonfunction fuze is not a dud and is not damaged by the plywood impact, an armor plate is positioned several feet behind the plywood as the fuze target. Function should occur on the armor target.

Ten rounds were fired during the ET phase to determine the sensitivity of the T278E8 fuze. Of three complete rounds with piezoelectric assemblies, all functioned on the plywood. Of seven rounds with piezoelectric assemblies removed, all passed through the plywood and functioned by graze action against the armor plate target positioned 12 ft beyond. This performance indicates that although the piezoelectric initiation requirement was not met, the fuze initiation element functioned as required. Since the agency developing the complete round is responsible for the piezoelectric

element, no action will be taken by HDL to alter the fuze sensitivity. (Additional details of these engineering tests have been reported by APG.¹)

5.2.5 Parachute Delivery Tests (Conducted by APG in 1963)

Eight fuzes were assembled to live M371 cartridges and dropped by normal parachute delivery from an altitude of 1100 ft at an airspeed of 90 knots. The fuzes were then disassembled from the ammunition, inspected, and reassembled for firing at ambient temperature. Using an armor plate target, the shells were fired at 0-deg obliquity at a range of 300 ft. All eight fuzes functioned as required. (Two of the fuzes functioned by action of the graze element—one caused by shell separation, and the other because of a damaged nose lead wire, which had been observed when the fuze was assembled to the shell.²)

Eight inert fuzes assembled to inert M371 cartridges were dropped by malfunctioning parachute from an altitude of 1300 ft at an airspeed of 100 knots. The fuzes were examined following the aerial delivery, and determined safe for handling and disposal.

5.3 Discussion of Performance

5.3.1 Graze Element

There was a slight degradation in graze sensitivity on graze impact with a very hard target at the extreme cold temperature. Sensitivity of the graze element could probably be increased by one or both of the following methods:

(a) Decreasing the stiffness of the 20- to 30-g creep spring used to restrain the graze plunger. The deceleration of the M371 shell is only about 2 g. A recent test of 50 M530 fuzes with 10-g springs indicates that an improvement in graze performance could be attained with the weaker springs. Also, it was indicated that the maximum permissible fuze sensitivity was not exceeded with use of the weaker springs. The shells were fired through a 1/4-in. target before the grazing impact; no functions occurred on the plywood. The creep spring used in current production of the M530 fuze has now been changed to a nominal 10-g spring. It is, therefore, anticipated that the M530A1 production fuze will also include the weaker spring. The weaker spring should be employed, however, with the M371 cartridge only.

¹ APG Report No. DPS-924, "USATECOM Project No. 8C-3402-02, Engineering Test of Fuze, PIBD, T278E8, in Cartridge, HEAT, M371 for 90-mm Rifle, M67 (U)," Robert H. Jines, Apr 1963.

² DPS Report No. 1076, "USATECOM Project No. 8-3-4020-OIC, Engineering Test of Fuze, PIBD, T278E8 (M530A1) in Cartridge, HEAT, M371, for Gun, 90-mm, Recoilless, M67 (Parachute Delivery)," Sept 1963.

(b) Because of the relatively high steel-on-aluminum coefficients of static and sliding friction between the graze plunger and housing, the lateral deceleration experienced by the shell grazing a hard surface tends to retard the graze plunger. The fuze performance is thereby limited on this type of target. Coating the graze plunger with a dry lubricant would minimize the friction coefficient and might improve performance at extreme cold temperature. The -E8 fuze was subjected to graze test, subsequent to the engineering tests, in which dry lubricant (a fluorocarbon telomer) was used on the graze weight. Some improvement was attained. Of 15 rounds conditioned at -40°F , 10 functioned on initial grazing impact with an asphalt target; this compares favorably with the 50-percent first-impact functions recorded in the ET.

5.3.2 Arming Delay

During the ED phase, limited field tests had indicated that the fuze provided more delayed arming distance than would be predicted from the static rotor arming time. As a further check on the fuze arming delay, the static rotor arming time of each fuze used in the ET was measured at room temperature. Since the velocity of each shell was also measured, it was believed that the arming distance probability curves for each temperature condition (marked "A" in fig. 15 and 16) would be predictable from the products of static rotor arming times and shell velocities. It may be noted that the predicted arming distance at -40°F was about 19 percent (7 to 8 ft) less than at $+160^{\circ}\text{F}$. The shorter arming distance at the extreme cold temperature is predicted from the corresponding 19 percent reduction in shell velocity at -40°F . Average shell velocity was 788 fps at $+160^{\circ}\text{F}$ and 638 fps at -40°F . The 19-percent predicted variation in arming delay assumes that rotor arming time does not change with temperature.

The arming distance probability curves determined from the ET firings (marked "B" in fig. 15 and 16) are considerably different from the predicted curves. These curves show that the fuze-arming distance was about the same at both temperature extremes despite the 19-percent velocity differential, and in both cases was greater than the predicted curves would indicate.

Laboratory tests were conducted to determine the cause for this behavior of the arming delay. The relatively constant arming distance over the temperature range indicated that the rotor arming time varies inversely with temperature. This performance, however, was contrary to laboratory test results obtained during the fuze development. In these tests, the static arming time was measured after removal of the fuze from the temperature-conditioning chamber; the arming time appeared to be independent of temperature. In tests performed subsequent to the ET, a method was devised for measuring

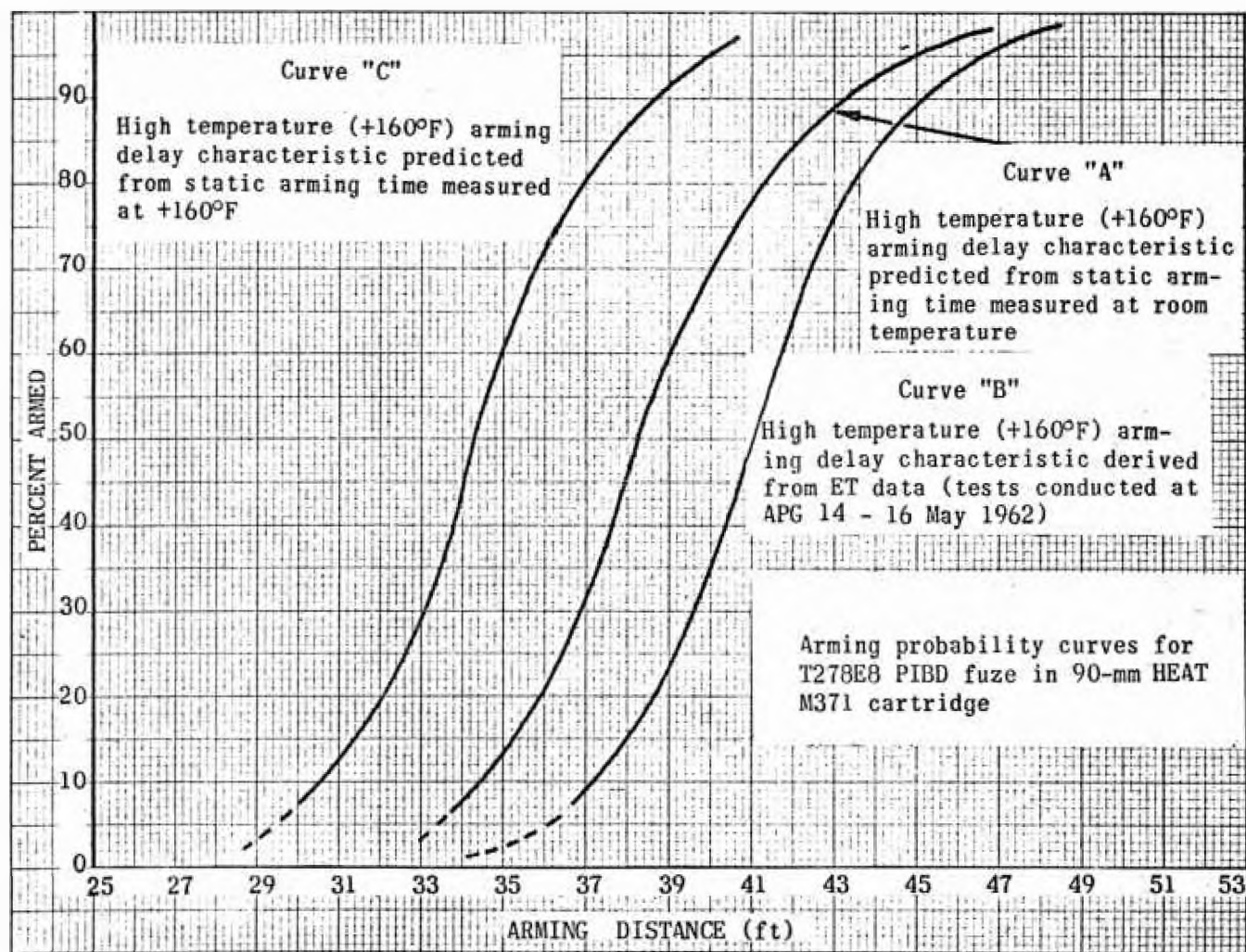

Figure 15. Arming delay characteristics at +160°F and room temperature.

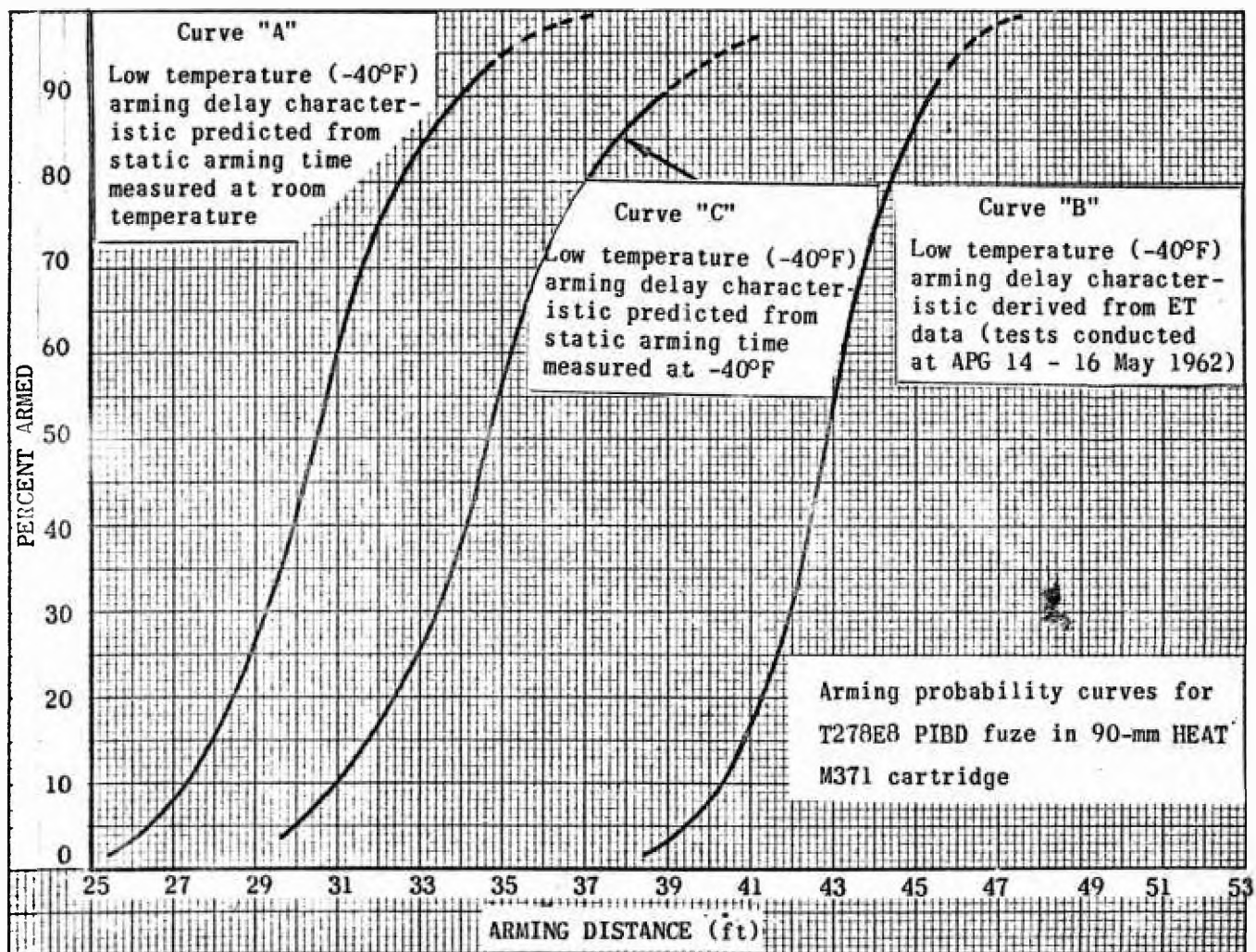

Figure 16. Arming delay characteristics at -40°F and room temperature.

the static rotor time while the fuze was inside the conditioning chamber. These tests confirmed the inverse-temperature relationship (fig. 14). (The linear relationship indicated is subject to revision.) Using these data, new predicted arming distance probability curves were plotted as shown in curves "C" in figures 15 and 16. These curves indicated that the predicted arming distance was almost identical at the temperature extremes, as had been noted in the curves plotted from the firing test data. However, the new predicted arming distance was about 7 to 8 ft (or roughly 20%) less than that recorded in the firing test. The reason for this discrepancy has not been fully established. The effects of projectile drag and spin, measured in separate laboratory tests at room temperature, do not appear to be contributing factors. A drag deceleration of 2 g, maximum for this round, will increase the average static rotor arming time only about 2 percent (fig. 13). There was no discernible increase in rotor arming time resulting from spinning the fuze about its longitudinal axis at rates as high as 15 rps during the arming cycle. The maximum spin rate of the M371 shell is 12 rps.

There is one ballistic phenomenon, however, which is believed capable of increasing the arming distance by several feet. As noted in this report, an acceleration of some 50 g will exert sufficient friction on the surface of the rotor to prevent arming. It has been observed that after a projectile leaves the rifle, propellant gas emerging from the muzzle at high velocity apparently continues to accelerate the round for several feet at a g-level that is believed sufficient to prevent initiation of rotor arming. No attempt has been made in this case to measure by high-speed photography the magnitude or duration of this residual firing acceleration, since the shell is obscured by propellant gas to an extent that makes this technique impractical.

5.4 Safety

The HDL Safety and Arming Certification Board certified the T278E8 PIBD fuze on 30 Oct 1962 for tactical field use in fin-stabilized artillery.

6. CONCLUSIONS

The design objective to develop a PIBD fuze for use in the M371 90-mm recoilless HEAT cartridge has been accomplished in the T278E8 (M530A1) model. Based on the laboratory and field test data:

- (a) The fuze meets the M371 delayed arming requirements;
- (b) The modifications made to attain the desired arming characteristics did not adversely affect the safety or performance.

It should be remembered that:

(c) Neither the -ES fuze nor the M530 is applicable for use in any shell whose deceleration in flight exceeds 20 g; and

(d) The T278E8 fuze should not be considered for standardization in any HEAT ammunition except the M371 cartridge without being first fully evaluated in the specific round.

APPENDIX A: ENGINEERING PARTS LIST FOR T278E8 PIBD FUZE

ORDNANCE CORPS		PARTS LIST NO. 10980600				
ENGINEERING PARTS LIST - LIST OF PARTS		SHEET 1	OF 2 SHEETS			
IDENTITY			DRAWING NO.			
FUZE, PIBD, T278E8			C10980600			
ITEM	ORDNANCE DRAWING NUMBER	PART NUMBER	NOMENCLATURE - DESCRIPTION	QUANTITY	UNIT	REMARKS
1	B10404075	10404075	COVER, ROOSTER	1		
2	B10404113	10404113	PELLET, ROOSTER	1		
3	B10404070	10404070	LEAD CUP ASSEMBLY	1		
4	B10404073	10404073	CUP, LEAD	1		
5	A10404114	10404114	CHARGE	1		
6	C10980594	10980594	ROTOR HOUSING AND SHIELD ASSEMBLY	1		
7	C10404107	10404107	SHIELD (MACHINED)	1		
8	B10404106	10404106	SHIELD, BLANK	1		
9	D10980592	10980592	ROTOR HOUSING AND RELEASE ASSEMBLY	1		
10	B10404091	10404091	SCREW	2		
11	A10404112	10404112	LOCTITE	(2)		
12	C10980597	10980597	HOUSING ASSEMBLY	1		
13	C10404089	10404089	RESISTOR, BLEEDER	1		
14	B10404111	10404111	INSULATOR, RESISTOR	1		
15	B10404097	10404097	WASHER, CONDUCTING	1		
16	C10980599	10980599	HOUSING CONTACT AND PIN ASSEMBLY	1		
17	B10404068	10404068	HOUSING CONTACT ASSEMBLY	1		
18	B10404100	10404100	BUSHING, CONTACT	1		
19	C10980589	10980589	HOUSING, ROTOR	1		
20	B10404084	10404084	ROLL PIN	1		
21	B10404105	10404105	SCREW, TERMINAL	1		
22	B10404069	10404069	GRAZE PLUNGER ASSEMBLY	1		
23	C10404082	10404082	PLUNGER	1		
24	B10404083	10404083	PIN, GRAZE	1		
25	B10404094	10404094	SPRING, CREEP	1		
26	P85700	85700	PRIMER	1		
27	B10404099	10404099	SPACER, BACKUP	1		
28	C10404074	10404074	CLIP, SPEED	1		
29	C10980591	10980591	RELEASE MECHANISM AND ROTOR ASSEMBLY	1		
30	C10980598	10980598	ROTOR ASSEMBLY	1		
31	B10980596	10980596	ROTOR AND PIN ASSEMBLY	1		
32	B10404081	10404081	PIN, ROTOR	1		
33	C10980580	10980580	ROTOR	1		
34	B10404067	10404067	DETONATOR AND CONTACT ASSEMBLY	1		
35	P-85443	85443	T74 DETONATOR	1		
36	B10404077	10404077	HOUSING, CONTACT	1		
37	B10404108	10404108	INSULATOR, CONTACT	1		
38	B10404101	10404101	CONTACT	1		
39	B10404093	10404093	SPRING, CONTACT	1		
40	B10404078	10404078	SPEED NUT	1		
41	D10980595	10980595	RELEASE MECHANISM ASSEMBLY	1		

APPENDIX A: ENGINEERING PARTS LIST FOR T278E8 PIBD FUZE—Cont'd

ORDNANCE CORPS		PARTS LIST NO. 10980600				
ENGINEERING PARTS LIST - LIST OF PARTS		SHEET 2	OF 2 SHEETS			
IDENTITY			DRAWING NO.			
FUZE, PIBD, T278E8			C10980600			
ITEM NO.	ORDNANCE DRAWING NUMBER	PART NUMBER	NOMENCLATURE - DESCRIPTION	REQ'D PER UNIT	QTY	REMARKS
1	C10404061	10404061	REAR BEARING PLATE AND STUD ASSY.	1		
2	C10404088	10404088	PLATE, BEARING, REAR	1		
3	H10404103	10404103	STUD, SPACER	2		
4	H10404104	10404104	STUD, SPRING	2		
5	H10404080	10404080	PIN, LEAF	2		
6	C10404096	10404096	SPRING, ANTI RESET	1		
7	H10404064	10404064	LEAF NO. 3 ASSEMBLY	1		
8	C10404086	10404086	LEAF NO. 3	1		
9	H10404079	10404079	DOG, LEAF	1		
10	H10404063	10404063	LEAF NO. 2 ASSEMBLY	1		
11	C10404085	10404085	LEAF, SETBACK	1		
12	H10404079	10404079	DOG, LEAF	1		
13	C10404085	10404085	LEAF, SETBACK	1		
14	H10404095	10404095	SPRING, LEAF	2		
15	H10980593	10980593	FRONT BEARING PLATE AND			
16			SPACER ASSEMBLY	1		
17	C10980581	10980581	PLATE, BEARING, FRONT	1		
18	H10404098	10404098	SPACER, PLATE	2		
19	H10980584	10980584	STUD, BRACKET	1		
20	H10404090	10404090	SCREW	2		
21	A10404112	10404112	LOCTITE	①		
22	H10980579	10980579	SPRING, ROTOR	1		
23	H10980727	10980727	KEEPER	1		
24	C10980582	10980582	PALLET	1		
25	H10980590	10980590	BRACKET AND STAR WHEEL ASSEMBLY	1		
26	H10980583	10980583	BRACKET	1		
27	H10980585	10980585	STAR WHEEL	1		
28	H10980586	10980586	WASHER, STAR WHEEL	1		
29	H10980578	10980578	WASHER, STUD	1		
30	H10980726	10980726	SCREW, PALLET	1		
31	B7544463	---	APPLICATION OF TOLERANCES			
32						
33						
34						
35						
36						
37						
38						
39						
40						
41						

DISTRIBUTION

Commanding General
U.S. Army Materiel Command
Washington, D. C., 20315
Attn: AMCRD-DE

Commanding Officer
Picatinny Arsenal
Dover, New Jersey
Attn: SMUPA-DR5
Attn: SMUPA-DC3
Attn: SMUPA-VA6

Commanding General
U.S. Army Munitions Command
Dover, New Jersey
Attn: AMSMU-RE-EG

Commanding Officer
Limited Warfare Laboratory
Aberdeen Proving Ground, Maryland
Attn: E. Landis

Commanding General
U.S. Army Test and Evaluation Command
Aberdeen Proving Ground, Maryland
Attn: AMSTE (3 copies)

Defense Documentation Center
Cameron Station, Bldg No. 5
5010 Duke Street
Alexandria, Virginia
Attn: TISIA (20 copies)

Internal

Horton, B. M./Hochmuth, M. S., Lt Col
Apstein, M./Gerwin, H. L./Guarino, P. A./Kalmus, H. P.
Spates, J. E./Schwenk, C. C.

Hardin, C. D., Lab 100
Sommer, H., Lab 200
Hatcher, R. D., Lab 300
Hoff, R. S., Lab 400
Nilson, H. M., Lab 500
Flyer, I. N., Lab 600
Campagna, J. H./Apolenis, C. J., Div 700
DeMasi, R., Div 800
Landis, P. E., Lab 900
Technical Reports Unit, 800
HDL Library (5 copies)
Technical Information Office (010) (5 copies)
Rotkin, I./Godfrey, T. B./Bryant, W. T.
Distad, M. F./McCoskey, R. E./Moorhead, J. G.

Seaton, J. W., 260
Fisher, E., 430
Piper, W., 450
Tokarcik, J. W., 710
DeWaal, W. R., 710
Richmond, L., 620 (6 copies)

UNCLASSIFIED

AD

Accession No. _____

Harry Diamond Laboratories, Washington, D. C.

SUMMARY REPORT—FUZE, FIBD, T27828 - Louis Richmond

TR-1155, 30 October 1963, 29 pp text, 17 illus, DAE050201909
AMCNS Code 5530.12.64010.03, HDL Proj # 43500, UNCLASSIFIED
Report

Development and performance of the T27828 point-initiated, base-detonating (PIBD) fuze are summarized. The fuze (standardized M530A1) was designed primarily for use in the M371 90-mm recoilless HEAT cartridge, but may also be used in other low and intermediate velocity HEAT shells whose drag does not exceed about 20 g.

The performance characteristics of the T27828 are compared with those of the M509E5 and M530 standard electric PIBD fuzes. These fuzes, which have been available for HEAT ammunition in the 76- to 120-mm range, are essentially similar in basic design and operation to the T27828. The major difference is that the T27828 fuze provides a minimum of 30 ft delayed arming in the M371 round, a feature that is not attainable by the other standard PIBD fuzes.

1. Base detonating fuzes—Design modifications
2. Projectile fuzes—PIBD designs
3. Impact fuzes—Design and performance
4. PIBD fuzes—Design summary
5. Antitank ammunition
6. Electric fuzes
 1. HEAT cartridge (M371)

UNCLASSIFIED

AD

Accession No. _____

Harry Diamond Laboratories, Washington, D. C.

SUMMARY REPORT—FUZE, FIBD, T27828 - Louis Richmond

TR-1155, 30 October 1963, 29 pp text, 17 illus, DAE050201909
AMCNS Code 5530.12.64010.03, HDL Proj # 43500, UNCLASSIFIED
Report

Development and performance of the T27828 point-initiated, base-detonating (PIBD) fuze are summarized. The fuze (standardized M530A1) was designed primarily for use in the M371 90-mm recoilless HEAT cartridge, but may also be used in other low and intermediate velocity HEAT shells whose drag does not exceed about 20 g.

The performance characteristics of the T27828 are compared with those of the M509E5 and M530 standard electric PIBD fuzes. These fuzes, which have been available for HEAT ammunition in the 76- to 120-mm range, are essentially similar in basic design and operation to the T27828. The major difference is that the T27828 fuze provides a minimum of 30 ft delayed arming in the M371 round, a feature that is not attainable by the other standard PIBD fuzes.

1. Base detonating fuzes—Design modifications
2. Projectile fuzes—PIBD designs
3. Impact fuzes—Design and performance
4. PIBD fuzes—Design summary
5. Antitank ammunition
6. Electric fuzes
 1. HEAT cartridge (M371)

UNCLASSIFIED

UNCLASSIFIED

AD

Accession No. _____

Harry Diamond Laboratories, Washington, D. C.

SUMMARY REPORT—FUZE, FIBD, T27828 - Louis Richmond

TR-1155, 30 October 1963, 29 pp text, 17 illus, DAE050201909
AMCNS Code 5530.12.64010.03, HDL Proj # 43500, UNCLASSIFIED
Report

Development and performance of the T27828 point-initiated, base-detonating (PIBD) fuze are summarized. The fuze (standardized M530A1) was designed primarily for use in the M371 90-mm recoilless HEAT cartridge, but may also be used in other low and intermediate velocity HEAT shells whose drag does not exceed about 20 g.

The performance characteristics of the T27828 are compared with those of the M509E5 and M530 standard electric PIBD fuzes. These fuzes, which have been available for HEAT ammunition in the 76- to 120-mm range, are essentially similar in basic design and operation to the T27828. The major difference is that the T27828 fuze provides a minimum of 30 ft delayed arming in the M371 round, a feature that is not attainable by the other standard PIBD fuzes.

1. Base detonating fuzes—Design modifications
2. Projectile fuzes—PIBD designs
3. Impact fuzes—Design and performance
4. PIBD fuzes—Design summary
5. Antitank ammunition
6. Electric fuzes
 1. HEAT cartridge (M371)

UNCLASSIFIED

AD

Accession No. _____

Harry Diamond Laboratories, Washington, D. C.

SUMMARY REPORT—FUZE, FIBD, T27828 - Louis Richmond

TR-1155, 30 October 1963, 29 pp text, 17 illus, DAE050201909
AMCNS Code 5530.12.64010.03, HDL Proj # 43500, UNCLASSIFIED
Report

Development and performance of the T27828 point-initiated, base-detonating (PIBD) fuze are summarized. The fuze (standardized M530A1) was designed primarily for use in the M371 90-mm recoilless HEAT cartridge, but may also be used in other low and intermediate velocity HEAT shells whose drag does not exceed about 20 g.

The performance characteristics of the T27828 are compared with those of the M509E5 and M530 standard electric PIBD fuzes. These fuzes, which have been available for HEAT ammunition in the 76- to 120-mm range, are essentially similar in basic design and operation to the T27828. The major difference is that the T27828 fuze provides a minimum of 30 ft delayed arming in the M371 round, a feature that is not attainable by the other standard PIBD fuzes.

1. Base detonating fuzes—Design modifications
2. Projectile fuzes—PIBD designs
3. Impact fuzes—Design and performance
4. PIBD fuzes—Design summary
5. Antitank ammunition
6. Electric fuzes
 1. HEAT cartridge (M371)

UNCLASSIFIED

UNCLASSIFIED

REMOVAL OF EACH CARD WILL BE NOTED ON INSIDE BACK COVER, AND REMOVED CARDS WILL BE TREATED AS REQUIRED BY THEIR SECURITY CLASSIFICATION.

UNCLASSIFIED

UNCLASSIFIED