

# **Communist Block Projected Munitions**

## **Fuzes in Vietnam**



**Information Prepared by Combined Material  
Exploitation Center, RVN, in Conjunction  
with 7AF Mobile EOD Team**

**Reproduction Courtesy HQ PACAF (DMWPE)**

**23 September 1968**

## PURPOSE

This manual is designed as an aid in identifying Communist Bloc projected munition fuzes employed against Free World Forces in Viet Nam. It is a technical catalog with a mission of supplying general technical data, to those personnel who require such information. It is believed that this will assist Explosive Ordnance Disposal teams, Intelligence activities, Wound Ballistics Teams, Ordnance personnel, munition design agencies and Field Commanders in the successful accomplishment of their assigned mission.

## SCOPE

(a) This publication outlines the technical characteristics, current status, brief history of use and detailed functioning of Communist Bloc Projected Munition Fuzes encountered in Viet Nam. The manual covers only standard production fuzes and does not include improvised fuzes produced in VC clandestine munition shops. This manual does not cover emplaced nor air dropped fuzes, nor does it include hand grenade fuzes. Later additions may include **these** items to provide a complete fuze catalog.

(b) The fuzes are arranged by tactical class and are sub-divided by functioning groups. These groups are further sub-divided by country of origin. Within each subdivision the fuzes are arranged alphabetically by designation and model number of the country of origin. Fuzes with numerical designations are listed in ascending order.

(c) The technical information contained herein is general in nature and, in most instances, has been derived from the actual examination of fuzes. In some instances, parts removed from shell craters have been inter-changed to reconstruct fuzes. Some errors in dimensions, weights and completeness of these fuzes must be admitted. Information on those fuzes that have not actually been examined have been extracted from documents considered accurate. It is known that fuzes other than those reported herein exist, but no specimens have been recovered for examination and reliable data is not available.

## GENERAL

Communist Bloc fuzes designed and produced since 1950 show a marked improvement in ability to withstand adverse environment, over earlier fuzes. The Bloc armament industry has lavished great effort and expense to insure that fuzes are completely moisture proof and robust enough to maintain alignment while penetrating hard mediums during delay functioning. This munition philosophy is highly commendable and should serve as a guide for future fuze development by the munition industries of Free World Forces.

## GENERAL (con't)

Generally speaking, Communist Bloc fuzes are exact copies of their Soviet counterparts. However, considerable evidence exists to show that the Chinese Communists are capable of producing efficient and effective indigenous fuzes. This trend is expected to continue, but Soviet munition design philosophies will continue to be followed closely. The ChiComs appear to be adherents to the dual reaction principle for reliable fuze functioning in their indigenous fuzes. This principle includes direct firing pin action upon impact, as well as primer-detonator inertial movement. This principle has been proved sound by its display of extreme reliability as well as offering graze sensitivity.

## ADDITIONS AND CORRECTIONS

Additions and corrections to this publication are invited and encouraged. All such comments should be addressed to: U. S. Director, Combined Materiel Exploitation Center, AFO 96307

CHAPTER 1

SOVIET FUZES FOR AIRCRAFT AND ANTI-AIRCRAFT GUNS

1-1/1-11

## GENERAL

All fuzes of this classification are improved modifications of earlier known fuzes. They are all mechanical, point detonating, impact types that are designed to function reliably on light material targets. The aircraft gun fuzes appear to have been based upon World War II German types of proven reliability. In some instances exact copies of internal elements have been noted. In other cases German mechanical principles have been assimilated with Soviet munition philosophy design practices, resulting in a composite, but highly effective design.

The Soviet Anti-Aircraft gun fuzes all employ pyrotechnic type self-destruct features. Precisely the same principles are employed in fuzes used in weapons from 23mm through 57mm calibers. The purpose of the self-destruct feature is to destroy projectiles that miss targets, at an altitude where the fragmenting projectile will not endanger friendly ground units. A secondary purpose is to provide air bursts as a psychological factor in preventing accurate bombing.

All of the Soviet fuzes in the aircraft and anti-aircraft classification are bore safe, in that they are provided with mechanical features designed to prevent the fuze from arming while in the tube of the weapon. Some of the earlier fuzes are not detonator safe, by American standards, in that the explosive train is not interrupted to positively preclude an in-bore detonation. However, a major trend is indicated toward both bore and detonator safe fuzes. This is evidenced by the introduction of the MG and B series fuzes with their out-of-line detonator rotors.

The extreme effort in designing moisture and environment proof fuzes is seen in Aircraft and Anti-Aircraft Fuzes. It appears that the Soviets have great confidence in the moisture proofness of their ammunition, due to the small amount of attention being given to environment proof packing containers. Soviet shipping containers are little more than a means of protecting the ammunition from the normal hazards of shipping and handling.

Soviet fuzes are marked plainly on the ogive. Each fuze is die stamped with the fuze nomenclature. Where space is available the lot number, year of manufacture, and plant number are included. Anti-Aircraft fuzes are normally "blued" or painted black with an additional coating of varnish or epoxy to inhibit external corrosion. If the fuze is cadmium plated, the exterior epoxy or varnish coating is still applied. Some fuzes have been seen with colored lacquer on the nose. The significance of the color has not been determined. It has been noted that not all fuzes of a specific designation, produced by the same plant, have the color marking.

GENERAL (con't)

Normally air-craft and anti-aircraft fuzes do not require any preparation for firing or linking. The larger calibers, such as 57mm, possess fuzes with removable shipping caps to increase impact sensitivity, but it has not been determined what the presence of a cap signifies, other than as a shipping safety device.

SOVIET POINT DETONATING IMPACT FUZE MODEL A-20

a. General. The A-20 is similiar in construction and functioning to the A-23, although the two fuzes differ noticeably in length and shape. The A-20, by comparison, is short and squat. When assembled to a projectile, it has a visible length of about 0.56 inch (the corresponding dimension of the A-23 is about 0.95 inch). Both the A-20 and the A-23 are bore-safe. The A-20 is used in 20-mm aircraft ammunition. The A-20 employs a gaine type detonator-booster. The gaine is common in Soviet fuzes and was derived from French Schneider designs which were the parents of Russian artillery projectiles and fuzes.

b. Characteristics.

Action ----- instantaneous

Loaded weight ----- ?

Body material ----- steel

c. Functioning. Before firing, the coiled copper arming spring (4) prevents the firing pin (3) from reaching the gaine. The coiled spring presents a solid block to the firing pin and is the only safety device in the fuze. After the projectile has left the bore of the weapon, centrifugal force causes the arming spring to unwind, making the hole in its center large enough for the firing pin to pass through. On impact with the target, the nose disk (1) is crushed and the striker (2) drives the firing pin through the firing pin guide (5) and safety disk (6) into the detonator assembly (7), which activates the main charge of the projectile.

d. Weapons and projectiles with which used.

Weapons	Projectiles
20-mm: ShVAK aircraft gun	20-mm HEI-T ----- OZT

SOVIET POINT DETONATING IMPACT FUZE MODEL A-20

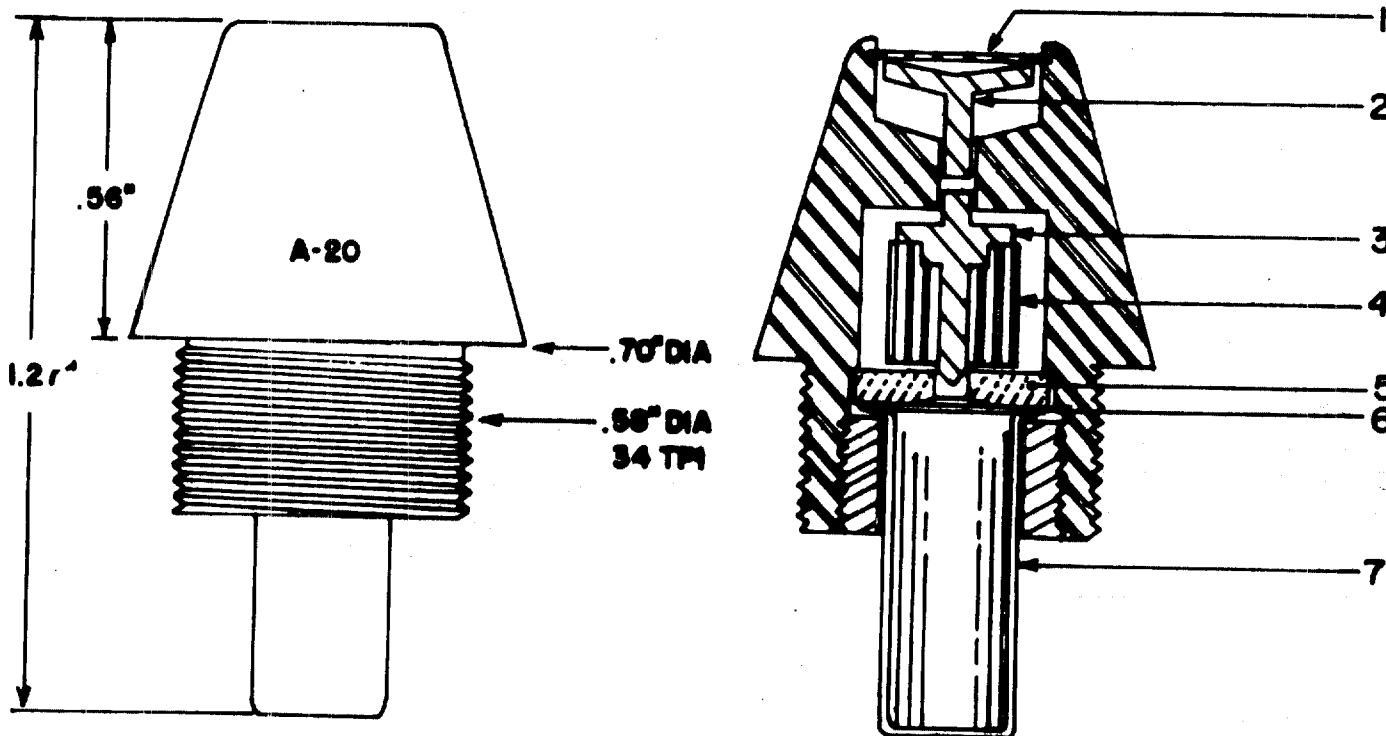

SOVIET POINT DETONATING IMPACT FUZE MODEL A-23

a. General. The A-23, although similar to the A-20 in construction and functioning, has an elongated shape which contrasts markedly with the A-20's stubby appearance. The A-23 consists of the following components: a steel nose disk, a steel fuze body, an aluminum striker and firing pin, a coiled copper arming spring, a brass spacer, a copper safety disk, a detonator, and an aluminium detonator retainer. The A-23, like the A-20, is boresafe. The well known MIG-15 and IL-28 are two types of aircraft that mount the 23-mm NR and NS guns in which the A-23 fuze is used.

b. Characteristics.

Action ----- instantaneous  
Loaded weight ----- 25.4 gm. (0.056 lb.)  
Body material ----- steel

c. Functioning. Before firing, the copper arming spring (4) prevents the firing pin (3) from reaching the detonator assembly (7). After the projectile has left the bore of the weapon, centrifugal force causes the arming spring to unwind, making the hole in its center large enough to allow the firing pin to pass through. On impact with the target, the nose disk (1) is crushed and the striker (2) drives the firing pin through the firing pin guide (5) and safety disk (6) into the detonator assembly (7), which activates the main charge of the projectile.

d. Weapons and projectiles with which used.

Weapons	Projectiles
23-mm: aircraft guns Model NR and Model NS	23-mm HEI-T ----- OZT
25-mm: antiaircraft gun M1940	25-mm Frag-I-T ----- OZR-132

SOVIET POINT DETONATING IMPACT FUZE MODEL A-23

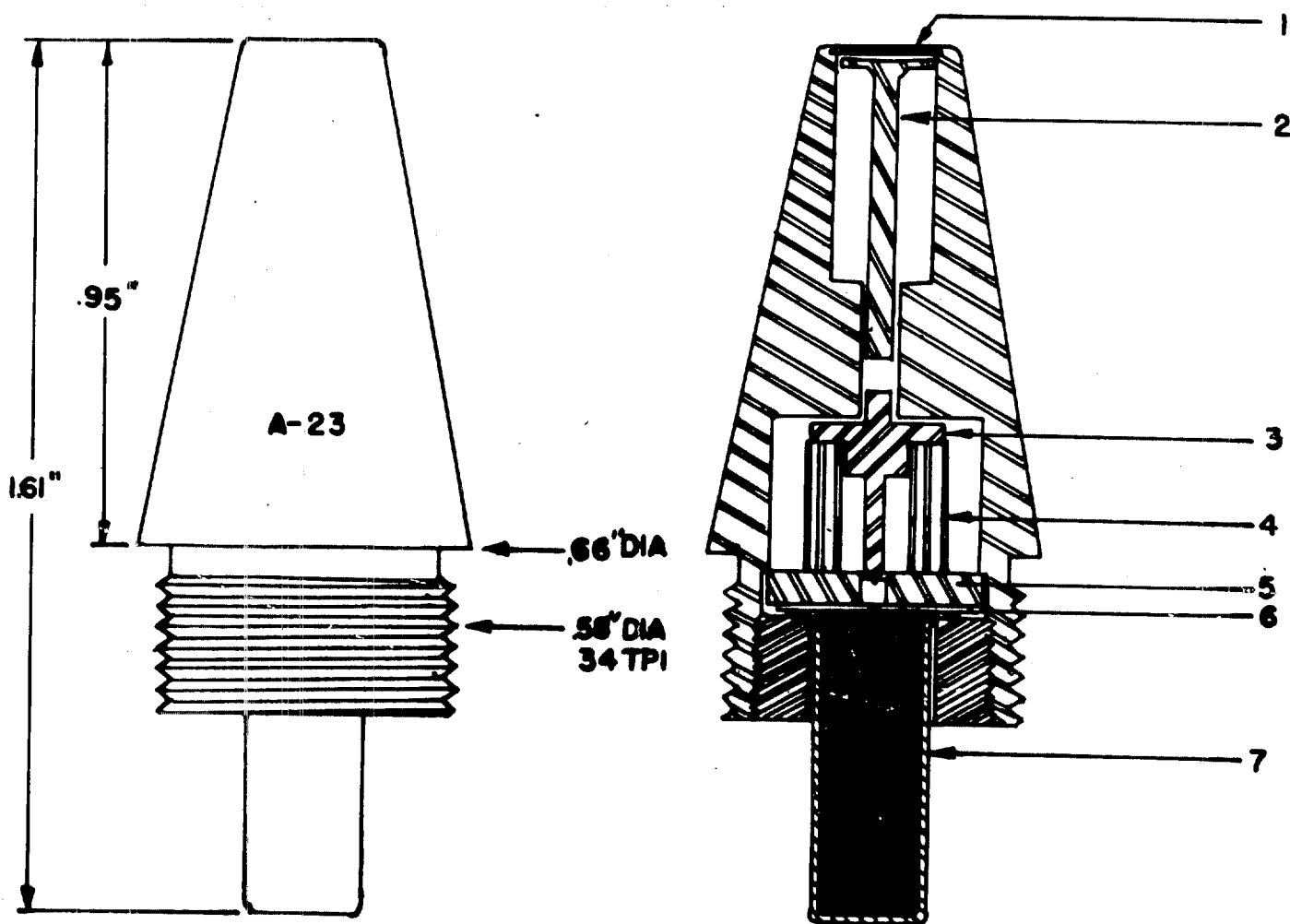

SOVIET POINT DETONATING IMPACT FUZE MODEL A-37

a. General. The A-37 is a sensitive, boresafe fuze with a self-destruction feature, and is designed for use with 37-mm aircraft guns. It is similiar to the MG-8 fuze and almost identical to the MG-37, the MGZ-37, and the B-37, (all of which are used with the 37-mm AA gun M1939), differing significantly from the latter only in having a shorter self-destruction powder train. Apparently because of its short self-destruction time causing undesirably early detonation, destroying the projectile at some point short of the effective combat range of the ammunition, the A-37 has been succeeded by a modified version, the A-37U, with a longer self-destruction powder train. The A-37, unless activated sooner by impact, will destroy itself after a flight of about 3 seconds; a flight of 10 - 12 seconds precedes self-destruction of the A-37U.

b. Characteristics.

Action ----- instantaneous  
Loaded weight ----- 179 gm. (0.39 lb.)  
Body material ----- steel

c. Functioning. On firing, the moveable setback igniter pellet (12) overcomes the resistance of the setback spring (13) and strikes the fixed setback firing pin (14). The resulting flash ignites both the self-destruction powder train (7) and a black powder pellet (15) which holds the centrifugal rotor locking pin (16) in place. As the black powder pellet burns, centrifugal force causes a second rotor locking pin (11) to compress its retaining spring and move outward from a recess in the rotor (3); after the black powder pellet is consumed, the first centrifugal locking pin (16) also moves out of its recess in the rotor, which is then free to rotate in the U-shaped trough of the rotor mount (6). (Since the locking pin (16) retained by the powder pellet immobilizes the rotor until the other locking pin (11) clears its straight-walled recess in the rotor, any possibility of the rotor jamming the latter pin (11) is precluded. The rotor recess for the pellet-retaining pin (16) has sloped walls, so that the movement of the rotor tends to cam this pin out of the recess, rather than to jam it). Centrifugal force causes the freed rotor whose center of gravity is located off the axis of rotation, to turn 90 degrees around the pivot pins (10), thus alining the primer charge (4) with the impact firing pin (2) and the detonator assembly (5). Upon impact with the target, the nose cap is crushed and the impact striker (1) drives the impact firing pin into the primer charge. The flash from the primer charge passes to the detonator assembly, which activates the booster (9), and the booster in turn activates the projectile's charge. If impact does not occur first, the burning powder train in the

SOVIET POINT DETONATING IMPACT FUZE MODEL A-37

self-destruction powder train ring (8) will ignite the black powder flash charge in the detonator, and the fuze will detonate from 2.5 to 3 seconds after the round is fired.

d. Weapons and projectiles with which used.

Weapons

Projectiles

37-mm: aircraft gun Models N & NS

37-mm HEI-T ----- OZT

SCALE 4:1

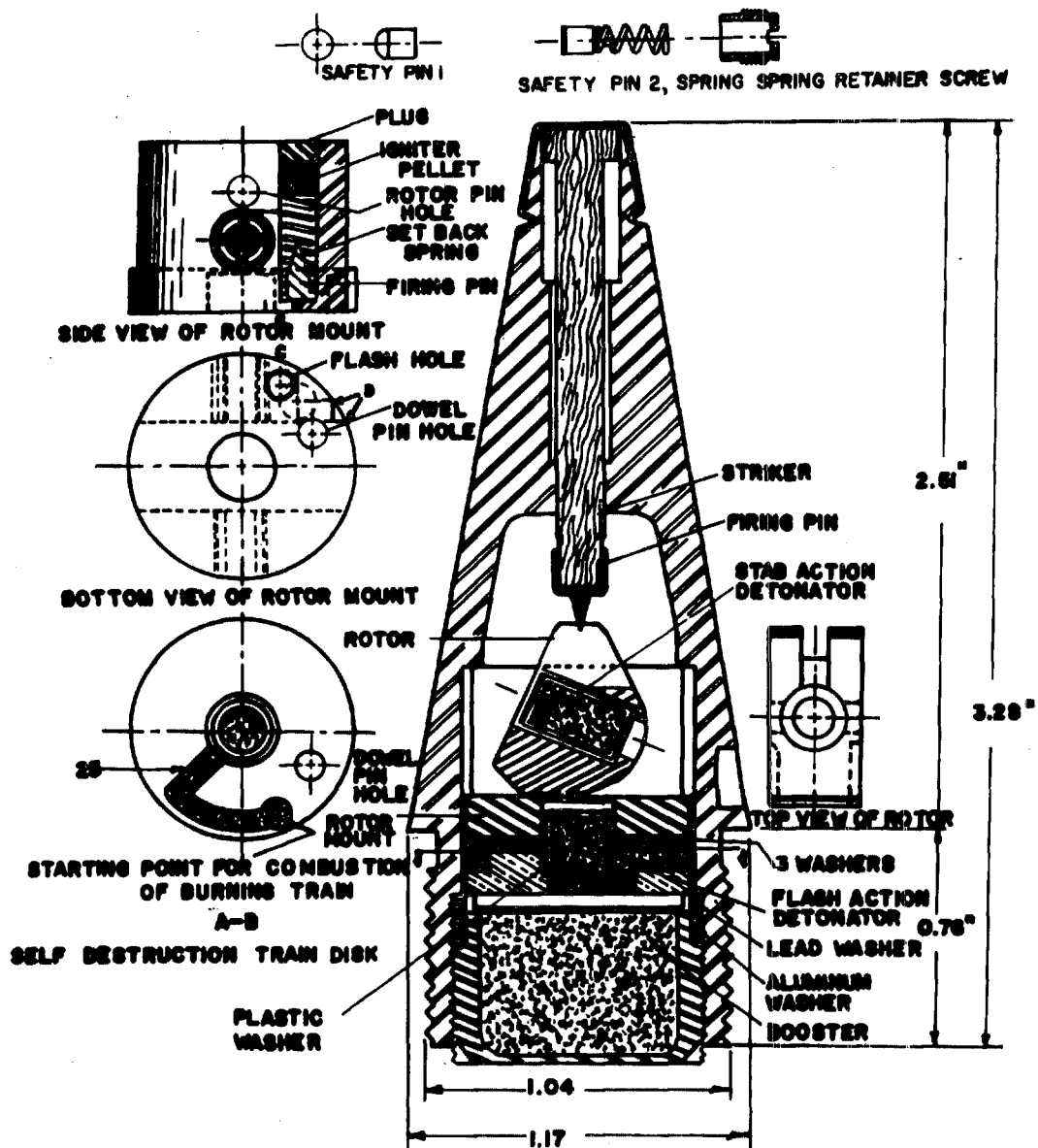

SOVIET POINT DETONATING IMPACT FUZE MODEL A-37U

The A-37U, a later version of the A-37, is essentially identical to the A-37 except for having a longer self-destruction powder train. Where the A-37 destroys itself after a flight of 2.5 - 3 seconds, the A-37U permits a flight of 10 - 12 seconds before self-destruction. It is believed that the time to self-destruction of the A-37U was lengthened in order to prevent detonations from occurring at points short of the effective ammunition combat range. If rounds fuzeed with the A-37U are fired horizontally at altitudes above 2500 feet, the increased time to self-destruction does not endanger ground personnel. This fuze is used with the same weapon and ammunition as the A-37.

SOVIET POINT DETONATING IMPACT FUZE B-30

a. General. Only a dummy version of the B-30 fuze has been examined. From its internal and external configuration it appears to be a slightly enlarged version of the MG-25 fuze. The self-destruct element may or may not be present. The steel fuze body has a single pin spanner hole near the bottom of the ogive. Threads are right handed with 34TPI. The fuze is secured with two stab crimps through the projectile. The dummy fuze examined possessed a steel nose disk and an aluminium striker. The remainder of the components were dummy and screwed into the body of the fuze with left hand threads. A recess for a lead sealing ring is present at the bottom of the fuze body to seal the booster to the body.

b. Characteristics.

Action ----- Instantaneous  
 Loaded weight ----- 1173.87 grains  
 Body material ----- steel

c. Functioning. No information on functioning is available.

d. Weapons and projectiles with which used.

Weapons	Projectiles
30-mm Aircraft Cannon NR-30	30-mm HEI-T ----- ?

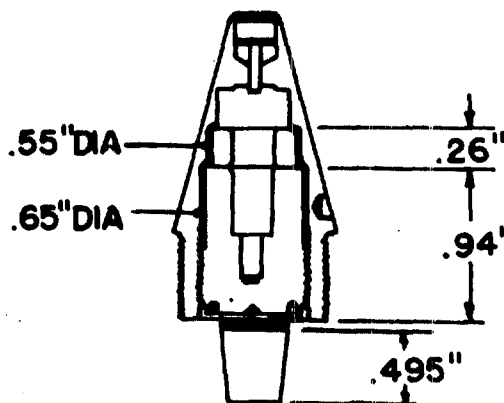
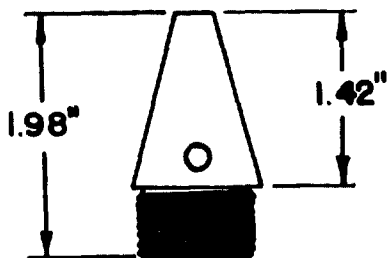

SOVIET POINT DETONATING IMPACT FUZE B-37

a. General. The Soviet B-37 is a modified copy of the Soviet MG-37. The fuzes and their functioning are essentially identical. The B-37 has a rotor lock and a slot (1) cut into the rotor housing to receive the pin. When the rotor rotates, the lock pin is forced into the slot (2) by centrifugal force. The detonator of the B-37 is retained in the rotor by a threaded keep ring (2) rather than by a press fit as in the case of the MG-37. The keep ring is slotted for a common screw driver. The B-37 has a conical depression (3) in the booster. A metal foil liner also has the same shape and covers the shaped explosive in the booster. The B-37 also has a portion of the fuze body and the booster cup relieved and a lead crush ring (4) pressed into the cavity. The lead ring renders the lower part of the fuze waterproof. The nose cup also has a vinyl ring (5) in the crimping groove at the nose of the fuze. When the nose cap is crimped into place, the vinyl ring (5) is compressed, rendering the nose of the fuze waterproof.

b. Characteristics.

Action ----- Instantaneous  
Loaded weight ----- 172 grams (0.38 lbs)  
Body material ----- steel

c. Functioning. This fuze is identical to the Soviet MG-37, except for the additional function of the rotor lock pin.

d. Weapons and projectiles with which used.

Weapons	Projectiles
37-mm Anti-Aircraft Gun M1939	37-mm Frag-T ----- CR-167

SOVIET POINT DETONATING IMPACT FUZE B-37

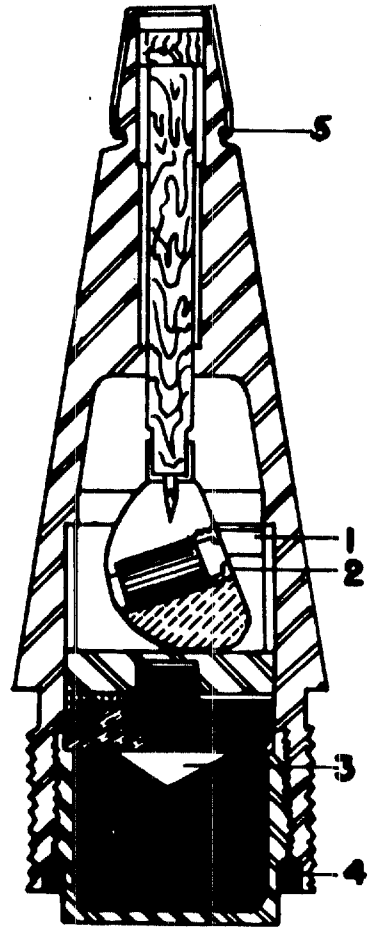
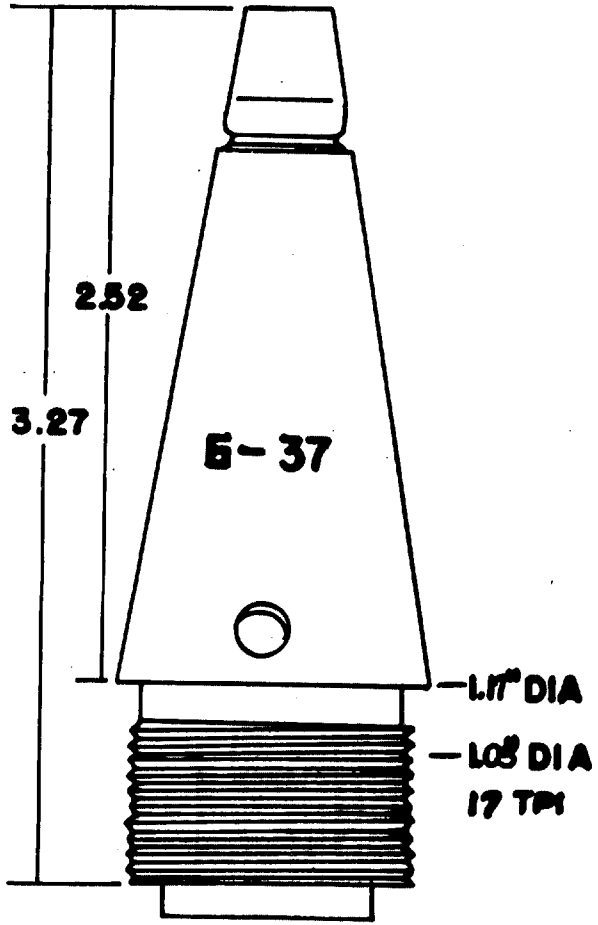

SOVIET POINT DETONATING IMPACT FUZE MODEL K-6

a. General. The K-6 is similar to the K-20 in construction and functioning, but is considerably smaller. It is a single action fuze, requires no special adjustments prior to firing, and is boresafe. A gaine type detonator-booster is employed. The K-6 exhibits an early version of the arming system employed in many current Soviet fuzes. The only modern departure is the addition of the Zig-Zag delay arming system.

b. Characteristics.

Action ----- instantaneous

Loaded weight ----- ?

Body material ----- steel

c. Functioning. Upon firing, inertia causes the arming sleeve (4) to set back, thereby releasing the arming sleeve retaining balls (3) and further compressing the arming spring (7). After the projectile leaves the bore, the arming spring overcomes inertia and moves the arming sleeve forward, freeing the two firing pin check balls (5); the two check balls then are thrown out of their housings in the firing pin guide (2) by centrifugal force, so that they no longer prevent the firing pin (6) from moving rearward. The firing pin is maintained in the forward position by creep action. On impact, The striker (1) is forced rearward, driving the firing pin through the safety disk (8) into the detonator assembly (9), and the resulting detonation activates the explosive charge of the projectile.

d. Weapons and projectiles with which fired.

Weapons

Projectiles

20-mm: ShVAK aircraft gun

20-mm HEI-T ----- OZT

SOVIET POINT DETONATING IMPACT FUZE MODEL K-6

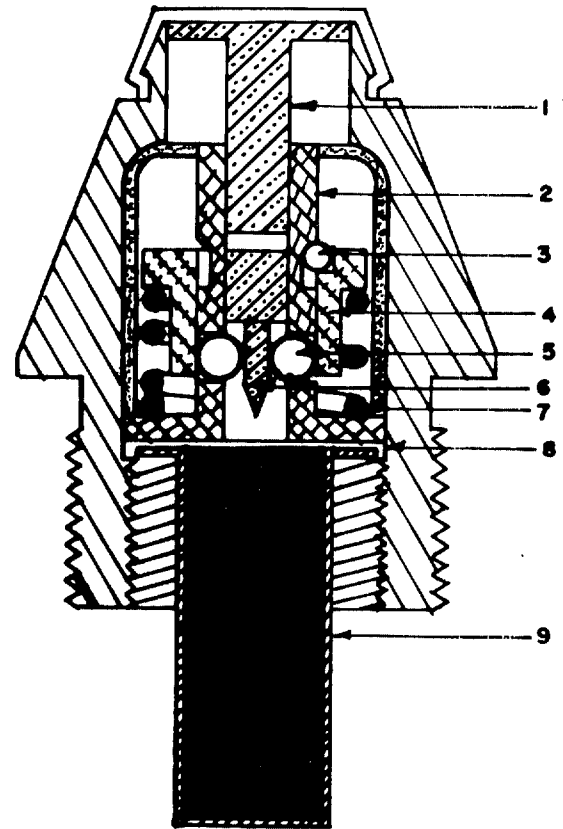
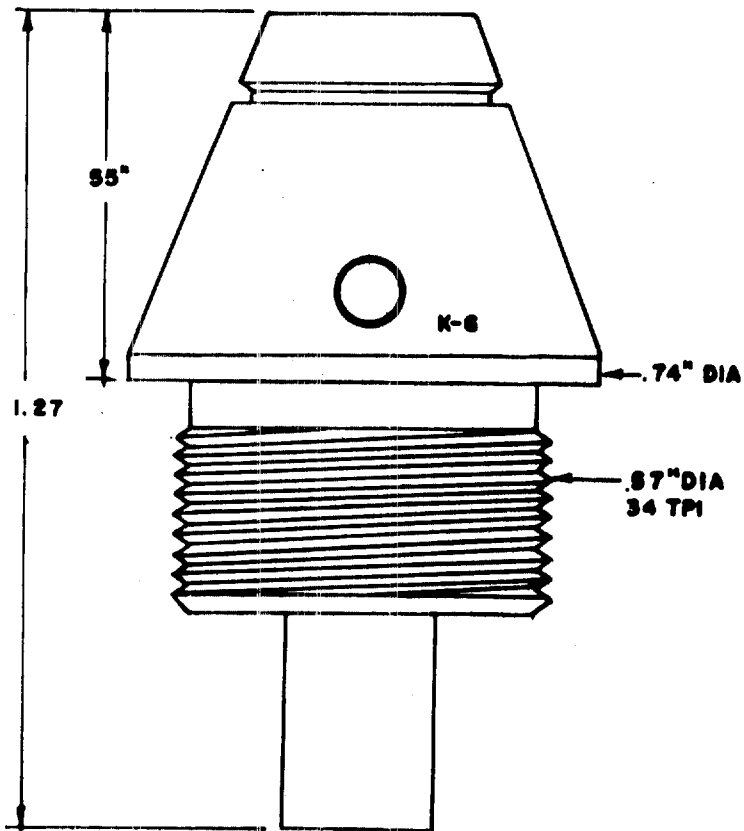

SOVIET POINT DETONATING IMPACT FUZE MODEL K-20

a. General. The K-20 is used with projectiles fired from 23-mm aircraft and 25-mm antiaircraft guns. Since it does not have a self-destroying element, the fuze will detonate upon contact with the ground or any other obstruction, if it misses the target. Although the K-20 is a boresafe fuze, it is supersensitive in the armed condition and should be handled with caution. The Soviet safety classification of the fuze is "unsecured." The K-20 possibly may be used in the 23-mm aircraft gun Models NR and NS, but evidence of its use with these weapons is lacking. The K-20 and the almost identical K-20M appear to have been replaced by the A-23 fuze, presumably because the latter, although less sensitive, is simpler and cheaper to manufacture.

b. Characteristics.

Action ----- instantaneous

Loaded weight ----- ?

Body material ----- steel

c. Functioning. Upon firing, the arming sleeve (4) sets back, compressing the arming sleeve spring (5) and creating an outlet for the three arming sleeve retaining balls (9). After the projectile has left the gun and centrifugal force has thrown the retaining balls out of their housings, the arming spring overcomes the diminishing force of inertia and moves the arming sleeves forward until it frees the two firing pin check balls (10). The check balls pass into the fuze body cavity through openings in the striker guide (3), and only the safety disk (7) remains between the firing pin (6) and the detonator assembly. Upon impact, the foil cap (1) is crushed inward, the striker (2) drives the firing pin through the safety disk into the detonator initiating pellet (8), and the resulting detonation activates the projectile's explosive charge.

d. Weapons and projectiles with which used.

Weapons	Projectiles
23-mm: aircraft gun Model VYa	23-mm HEI ----- ? HEI-T ----- OZT
25-mm: antiaircraft gun MI940	25-mm Frag-I-T ----- OZR-132

SOVIET POINT DETONATING IMPACT FUZE MODEL K-20

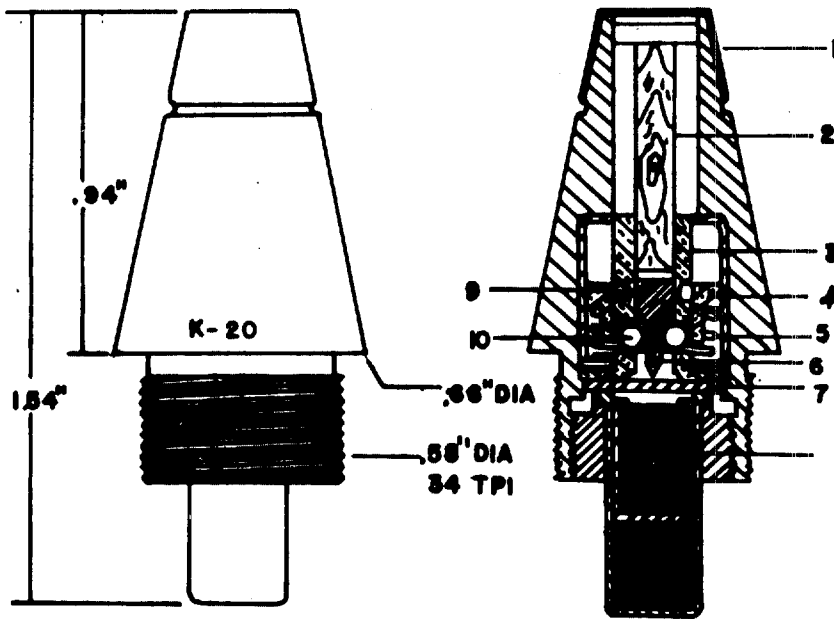

SOVIET POINT DETONATING IMPACT FUZES MODEL K-20M

a. General. The K-20M is identical to the K-20 in external dimensions, body material, functioning, and (except for sizes and the materials of certain parts) internal construction. It differs from the K-20 in outer appearance only by having a smooth, ungrooved body contour, and by mounting a foil disk in the top of the nose cavity instead of having a foil cap crimped over the nose. Any difference in loaded weights of the two fuzes is believed to be negligible.

b. Internal differences from the K-20.

- (1) The K-20M has a steel striker (1) with a shorter length and smaller head diameter; the diameter of the nose cavity, corresponding to the striker head, is likewise smaller. The K-20 striker, besides being larger, is made of wood or aluminum.
- (2) The firing pin (2) in the K-20M is longer than the K-20.
- (3) The full length of the detonator assembly retainer (3) is threaded, in the K-20M; in the K-20, there is an unthreaded shoulder at the top of this retainer.
- (4) The length of the detonator assembly (4) is greater for the K-20 fuze.

c. Weapons and projectiles with which used. The K-20M can be used with the same weapons and ammunitions as the K-20. Both fuzes appear to have been replaced by the A-23

SOVIET POINT DETONATING IMPACT FUZES MODEL K-20M

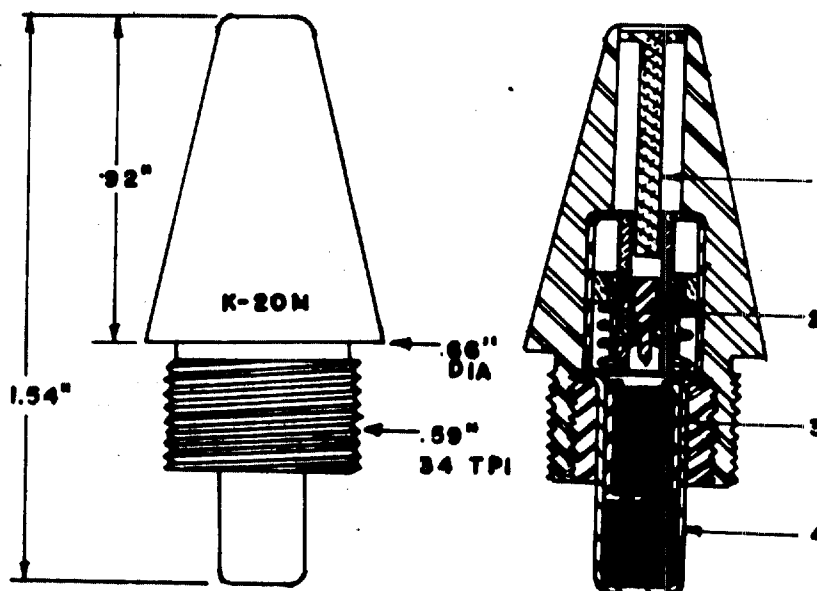

SOVIET POINT DETONATING IMPACT FUZE MODEL MG-8

a. General. The MG-8 (Malokalibernyy, Golovnoy, 8-y Obrazets: small-caliber, point detonating, Model 8) is a boresafe fuze which arms at approximately 50 - 100 meters from the muzzle of the gun. It incorporates a setback-actuated self-destruction feature which will cause the projectile to detonate 8 - 11 seconds after leaving the bore, provided that the target is not struck beforehand. The Soviet safety classification of the fuze is 'safe'. The MG-8 is similar in external appearance and internal construction to the later MG-37 antiaircraft fuze, and also closely resembles the A-37 and A-37U aircraft fuzes.

b. Characteristics.

Action ----- instantaneous

Loaded weight ----- ?

Body material ----- steel

c. Functioning. Upon firing, the setback igniter pellet (13) overcomes the resistance of the safety spring (14) and impings on the setback firing pin (15). The resulting flash simultaneously ignites the self-destruction powder train (11) in the powder train ring (10) and the black powder pellet (7) which holds the rotor locking pin (8) in place. (The flash presumably reaches powder pellet (7) through a channel not visible in the drawing) When the black powder pellet has burned away, centrifugal force moves the rotor locking pin out of the groove in the rotor (3), which is then free to rotate in the trough of the U-shaped rotor mount (4). Centrifugal force causes the freed rotor, whose center of gravity is located off the axis of rotation, to turn 90° around the pivot pins (6), thus alining the primer charge (5) with the impact firing pin (2) and the detonator assembly (9). Upon impact with the target, the nose cap is crushed and the striker (1) drives the impact firing pin into the primer charge. The flash from the primer charge passes to the detonator assembly, which activates the booster (12), thereby detonating the projectile. Should the projectile fail to hit the target, the burning self-destruction powder train ring (10) will ignite the detonator, and the fuze will function from 8 to 11 seconds after the round is fired. This length of time is sufficient to permit the projectile to travel beyond the maximum range at which it is normally used.

SOVIET POINT DETONATING IMPACT FUZE MODEL MG-8

d. Weapons and projectiles with which used.

Weapons

37-mm: antiaircraft gun M1939

Projectiles

37-mm Frag T ----- OR-167

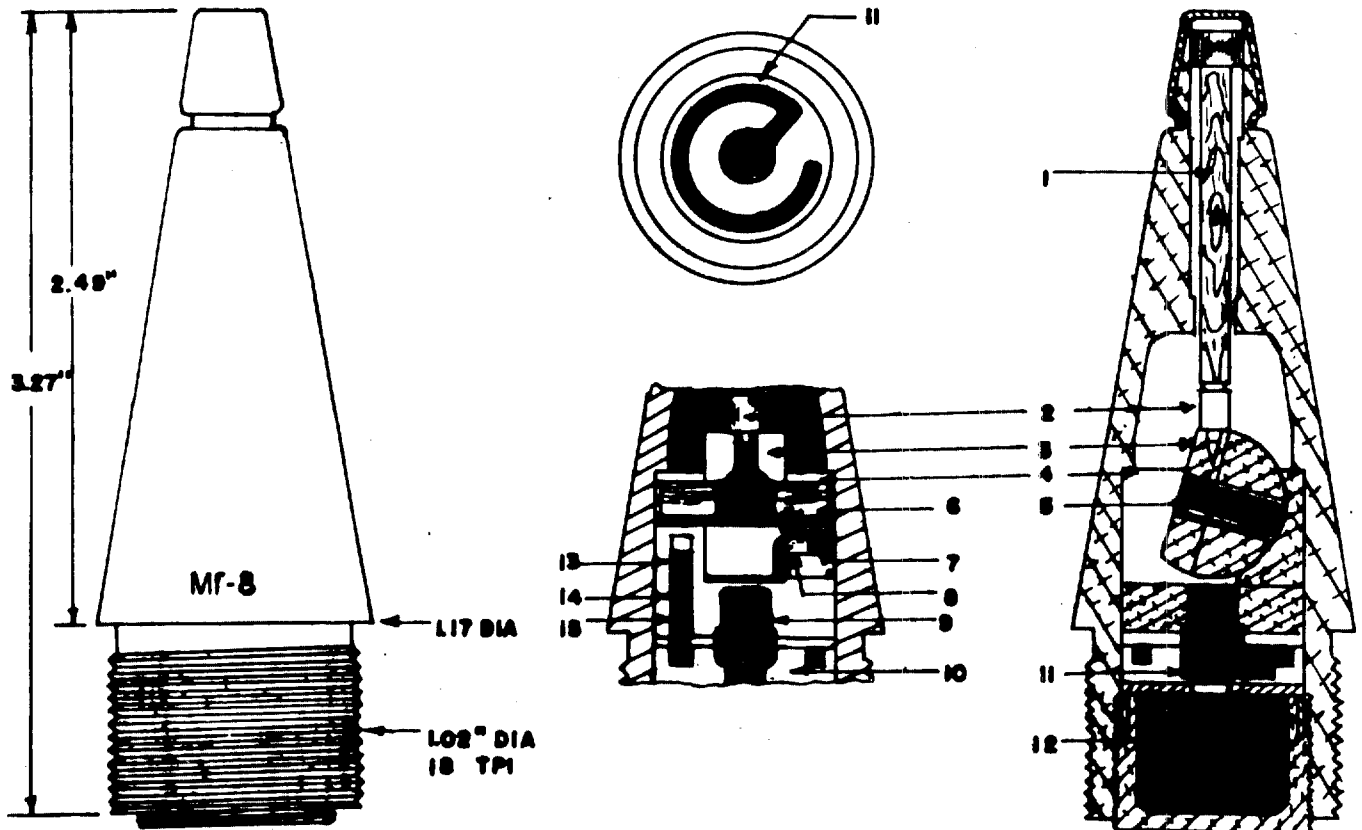

a. General. The MG-25 fuze is boresafe and is supersensitive in the armed condition. It contains a set-back actuated self-destruction feature that destroys the projectile between 5 and 8 seconds after firing, provided the target has not been hit beforehand.

The fuze has a thin aluminium foil membrane (1) over the firing pin cavity in the nose. Beneath the membrane is a floating firing pin extension (2). The floating firing pin extension passes through and is retained by a solid bulkhead, into the main fuze cavity. In this cavity, the firing pin (5) rests on a coiled centrifugal spring tape (4). The tape prevents the firing pin from reaching the primer. Surrounding the tape is a setback detent (3) that rests on a ring with four internal prongs (6). This safety ring (6) rests on top of an internal support (7). An aluminum cylinder (10) containing the self-destruct initiator (16), the self-destruct pyrotechnic delay element (22), the body primer (9) and a relay flash pellet (11) is threaded (left hand) into the steel fuze body. The self-destruct initiator (16) consists of a fixed firing pin (19) in the bottom of a cavity in the cylinder, a setback spring (17), and a weighted primer (16). The booster (13) screws into the bottom of the fuze body. Its twin flash holes (12) are directly beneath the relay flash pellet.

b. Characteristics.

Action ----- Instantaneous  
 Loaded weight ----- 30 grams  
 Body material ----- steel

Upon setback, the setback detent (3) moves downward, forcing its way through the four internal prongs in the safety ring (6). Simultaneously the weighted self-destruct flash pellet (16) moves downward compressing its spring (17) and impales itself on the fixed firing pin (19). The resulting flash passes through a lateral hole (18) from the self-destruct initiator cavity into the pyrotechnic delay cavity (20), igniting the self-destruct element (22). Centrifugal force then causes the coiled tape (4) to expand, releasing the firing pin (5). The firing pin (5) and the firing pin extension (2) move forward into their cavity by creep action. Upon impact, the firing pin extension (2) is driven rearward forcing the firing pin downward into the body primer (9). The resulting flash ignites the relay pellet (11) which causes flame to flash through the two flash holes in the booster cap, detonating the booster (13).

If the fuze fails to impact with the target, the pyrotechnic self-destruct element (22) will burn into a flash pellet (21) which flashes into the two flash holes (12) in the booster cap causing a detonation.

SOVIET POINT DETONATING IMPACT FUZE MG-25

d. Weapons and projectiles with which used.

Weapons

23-mm Anti-Aircraft Gun ZU-23

Projectiles

23-mm Frag HEI-T ----- OPZT

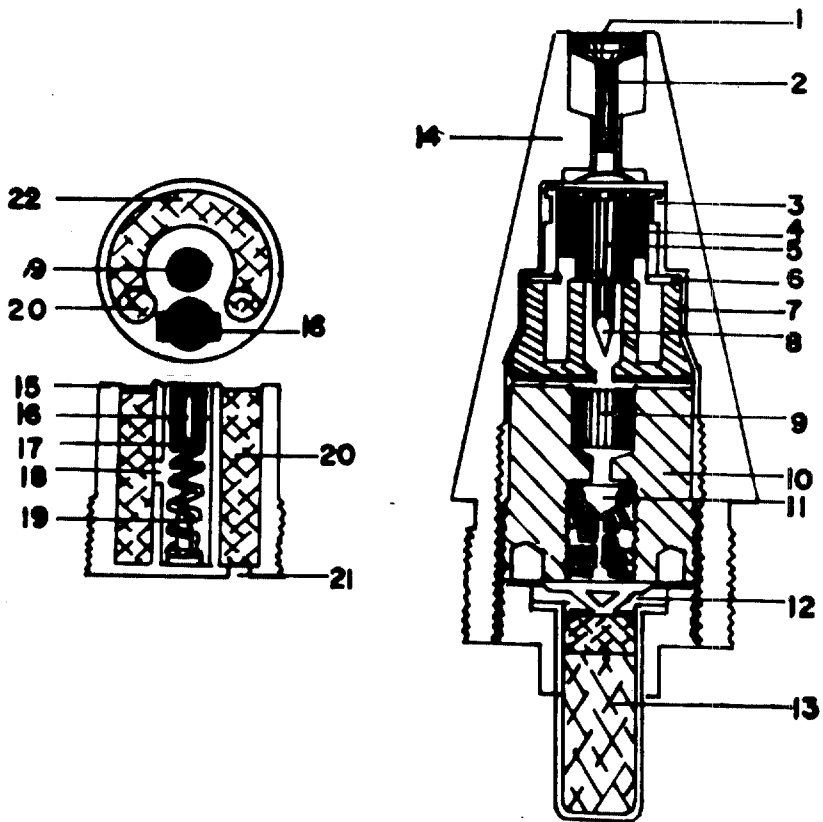

a. General. The MG-37, a later version of the World War II MG-8, is a boresafe fuze with a setback-actuated self-destruction feature that will detonate the fuze 10 - 12 seconds after the round is fired. It is almost identical to the MG-8 in external appearance, and its only major internal differences appear to be a redesigned rotor and an improved arming safety arrangement involving the use of two rotor locking pins instead of one. The MG-37 also bears a close resemblance to the A-37 and A-37U aircraft fuzes in external appearance, internal construction, and demensions, but available evidence indicates that the MG-37 is restricted to antiaircraftgun fire and is not interchangeable with aircraft fuzes.

b. Characteristics.

Action ----- instantaneous  
 Loaded weight ----- 172 gm. (0.38 lb.)  
 Body material ----- steel

c. Functioning. On firing, the setback igniter pellet (12) overcomes the resistance of the safety spring (13) and strikes the setback firing pin (14). The resulting flash ignites both the self-destruction powder train (7) and a black powder pellet (15) which holds a rotor locking pin (16) in place. As the black powder pellet burns, centrifugal force causes a second rotor locking pin (11) to compress its retaining spring and move out of a recess in the rotor (3); after the black powder pellet burns away, the locking pin (16) also moves out of its recess in the rotor, which is then free to rotate in the U-shaped trough of the rotor mount (6). (Since the locking pin (16) retained by the powder pellet immobilizes the rotor until the other locking pin (11) clears its straight-walled recess in the rotor, any possibility of the rotor jamming the latter pin is precluded. The rotor recess for the pellet-retained pin (16) has sloped walls, so the movement of the rotor tends to cam this pin out of the recess, rather than to jam it). Centrifugal force causes the freed rotor, whose center of gravity is located off the axis of rotation, to turn 90° around the pivot pins (10), thus alining the primer charge (4) with the impact firing pin (2) and the detonator assembly (5). Upon impact with the target, the nose cap is crushed and the impact striker (1) drives the impact firing pin into the primer charge. The flash from the primer charge passes to the detonator assembly, which activates the booster (9), and the booster in turn activates the projectile's explosive charge. If impact does not occur first, the burning self-destruction powder train in the powder train ring (8) will ignite the detonator, and the fuze will explode from 10 - 12 seconds after the round is fired.

SOVIET POINT DETONATING IMPACT FUZE MODEL MG-37

d. Weapons and projectiles with which used.

Weapons

37-mm: antiaircraft gun M1939

Projectiles

37-mm Frag T ----- OR-167

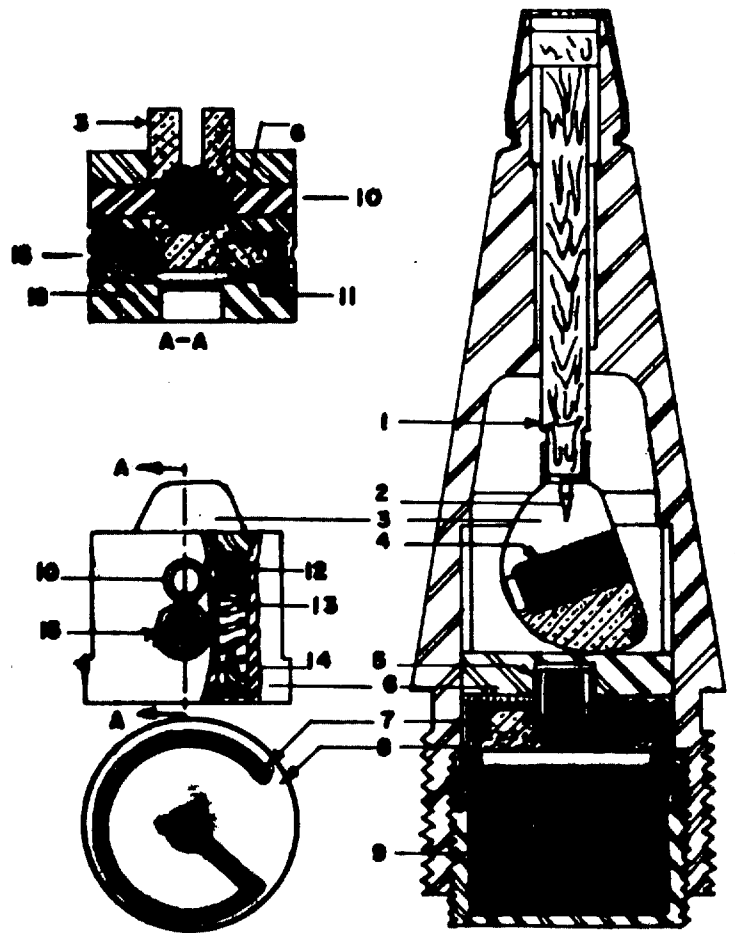
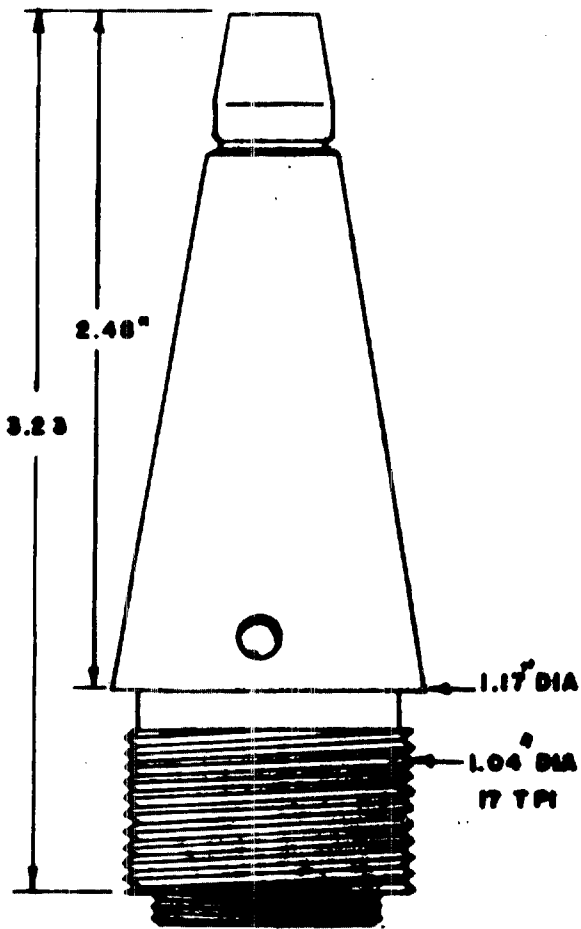

SOVIET POINT DETONATING IMPACT FUZE MODEL MG-57

a. General. The MG-57 is a bore safe, out of line detonator fuze. It employs a setback-actuated self-destruction feature that will cause the projectile to detonate 19 seconds after leaving the bore, providing no prior target impact occurs. A metal shipping cap (1) with pull wire protects the firing pin membrane during shipping. The firing pin is composed of a metal firing pin (4) attached to a wooden shaft (3). It locks the rotor (5) during setback. The rotor housing contains the self-destruct initiating mechanism. This consists of a weighted moveable, detonator, spring, and fixed firing pin. This assembly is parallel to the fuze axis. The main fuze detonator (7) sits in the center of the pyrotechnic self-destruct disc. The fuze features a delay arming, consumable, black powder detent that is initiated by the self-destruct flash pellet upon setback. The fuze arms by centrifugal force. The floating type firing pin used in the MG-57 makes it supersensitive.

b. Characteristics.

Action ----- Instantaneous  
Loaded weight ----- 335 grams (0.738 lbs.)  
Body material ----- Steel

c. Functioning. A detailed description of functioning can be found in the entry under the Soviet MG-37 fuze.

d. Weapons and projectiles with which used.

Weapons	Projectiles
57-mm: Soviet AA guns S-60	57-mm HE-Frag ----- OR-281

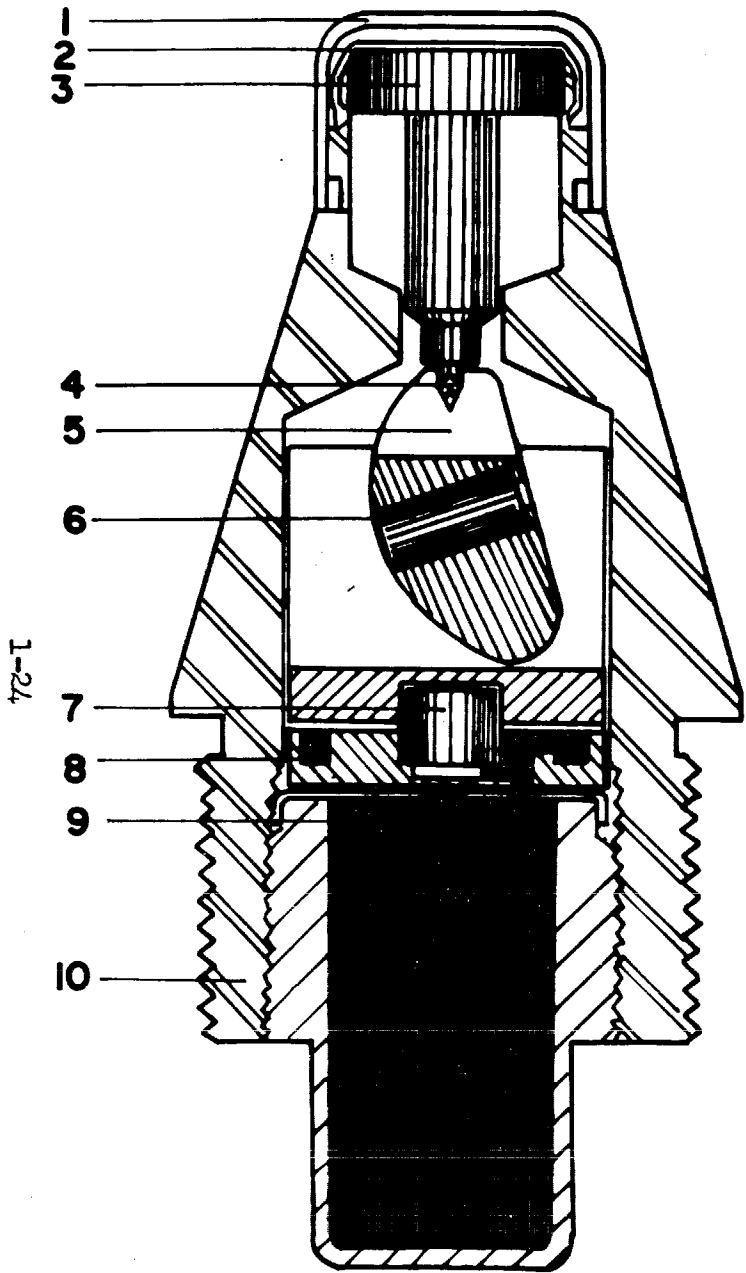

1-24

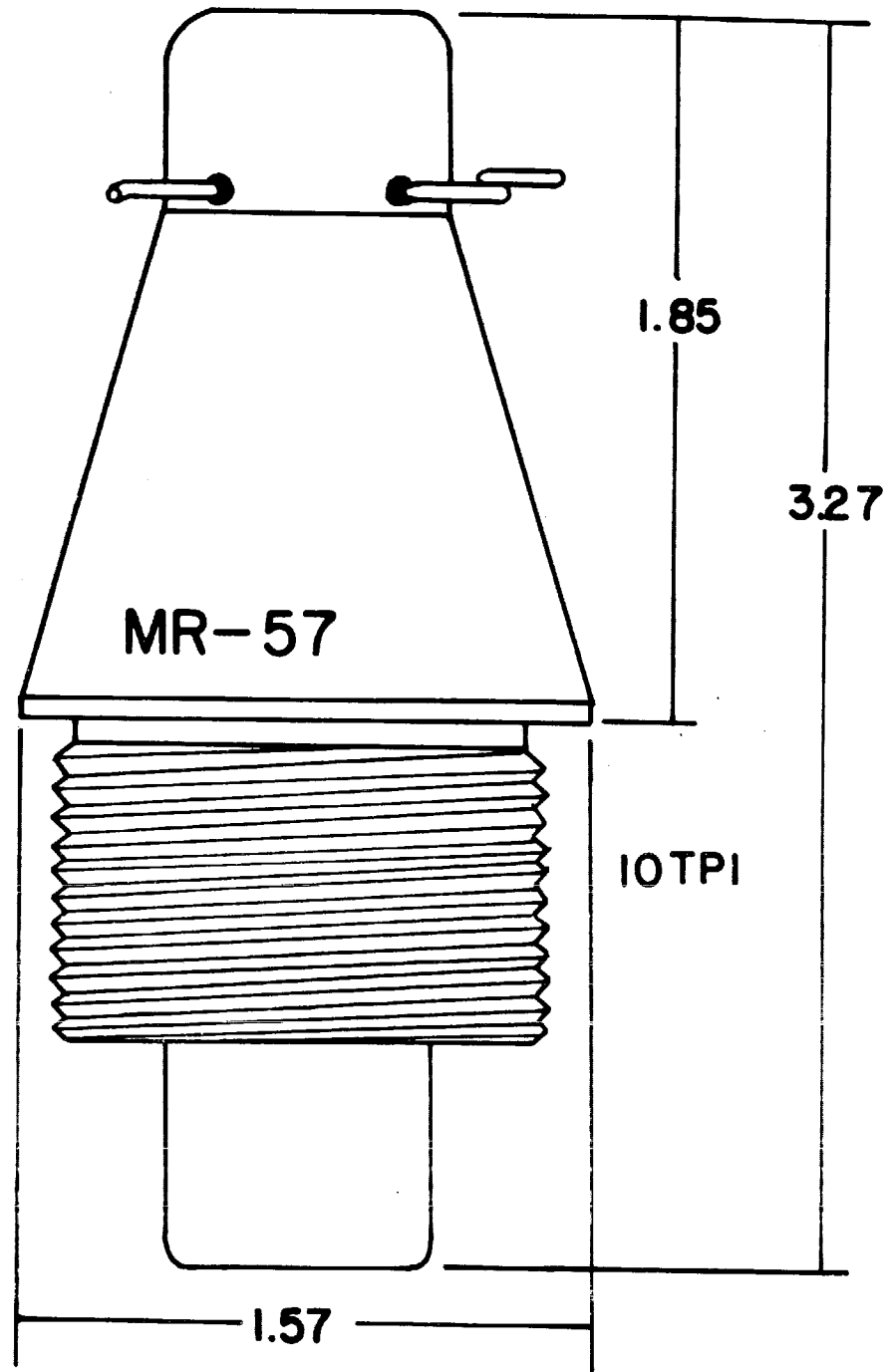

SOVIET POINT DEFORMATING IMPACT FUZE MODEL MC-57

SOVIET POINT DETONATING IMPACT FUZE MODEL MGZ-57

a. General. The MGZ-57 fuze is essentially identical with the MG-57, with certain modifications. It has a threaded metal shipping cap with four equi-distant holes near its upper rim. The thin aluminum crush cap is crimped into a groove cut into the fuze body. A vinyl sealing ring occupies the groove and makes the upper part of the fuze water proof. The firing pin is all metal versus metal and wood in the MG-57. There is also a spring under the firing pin head in lieu of a wax filler in the MG-57. The detonator in the rotor is held in position by a threaded ring. In the MG-57, the detonator is pressed and stab crimped in the rotor. The fuze body is recessed at the booster cavity to accept a vinyl water proofing ring and a steel lock ring. The lock ring employs the booster threads to compress the vinyl ring. The copper foil seal over the booster is conical concave. This same shape is formed into the PETN booster explosive. The booster on the MG-57 has a flat surface. The rotor has centrifugal locking pins to lock the rotor in the armed position.

b. Characteristics.

Action ----- nondelay  
Loaded weight ----- 314 gm. (0.691 lb.)  
Body material ----- steel

c. Functioning. When fired, setback causes the same functioning as occurs in the MG-57 fuze. Centrifugal force moves the spring retaining the rotor lock pin out of the rotor. When the delay arming black powder pellet is consumed the detent is moved into the evacuated cavity. The rotor then rotates to the armed position. Simultaneously, the rotor lock pin moves into a slot cut into the rotor cavity in the rotor housing, locking the rotor in the armed position. Functioning then continues in a manner identical to that of the MG-57 fuze.

d. Weapons and projectiles with which used.

Weapons

Projectiles

Identical to that of the Soviet MG-57 fuze.

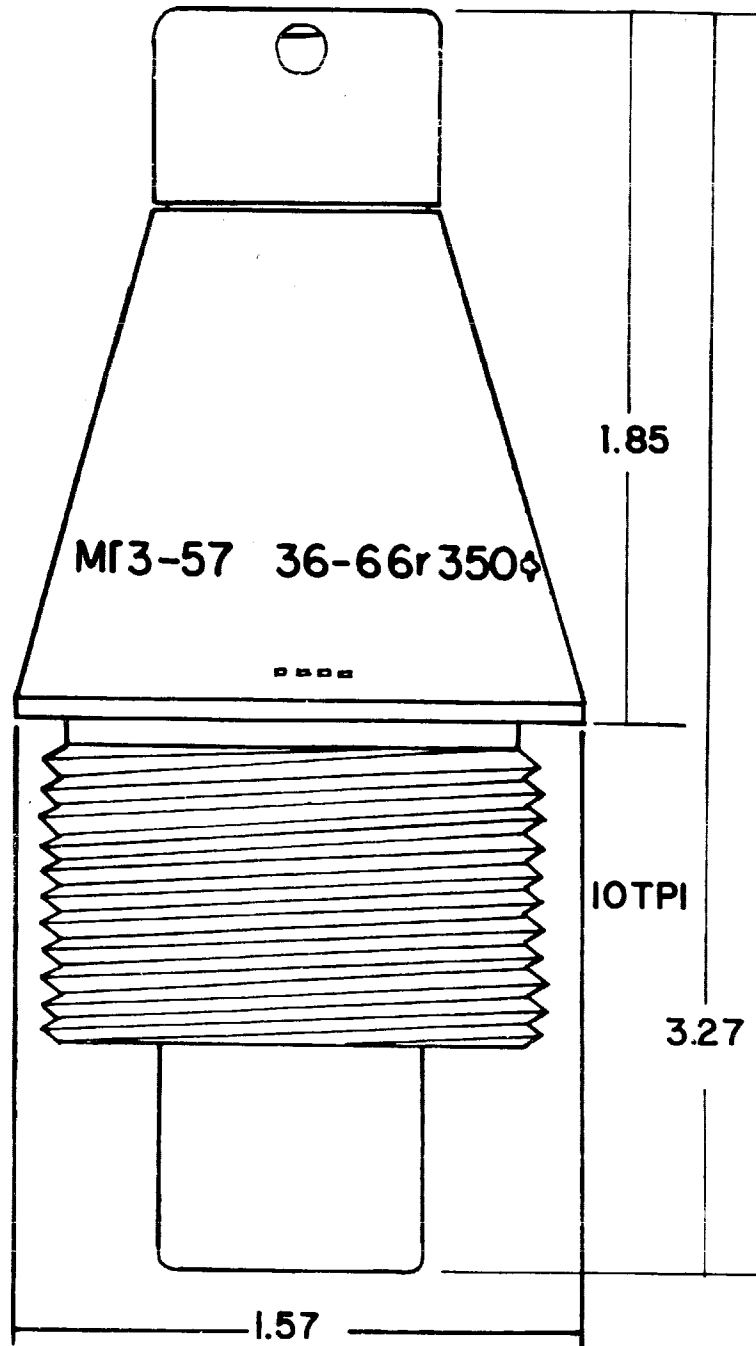
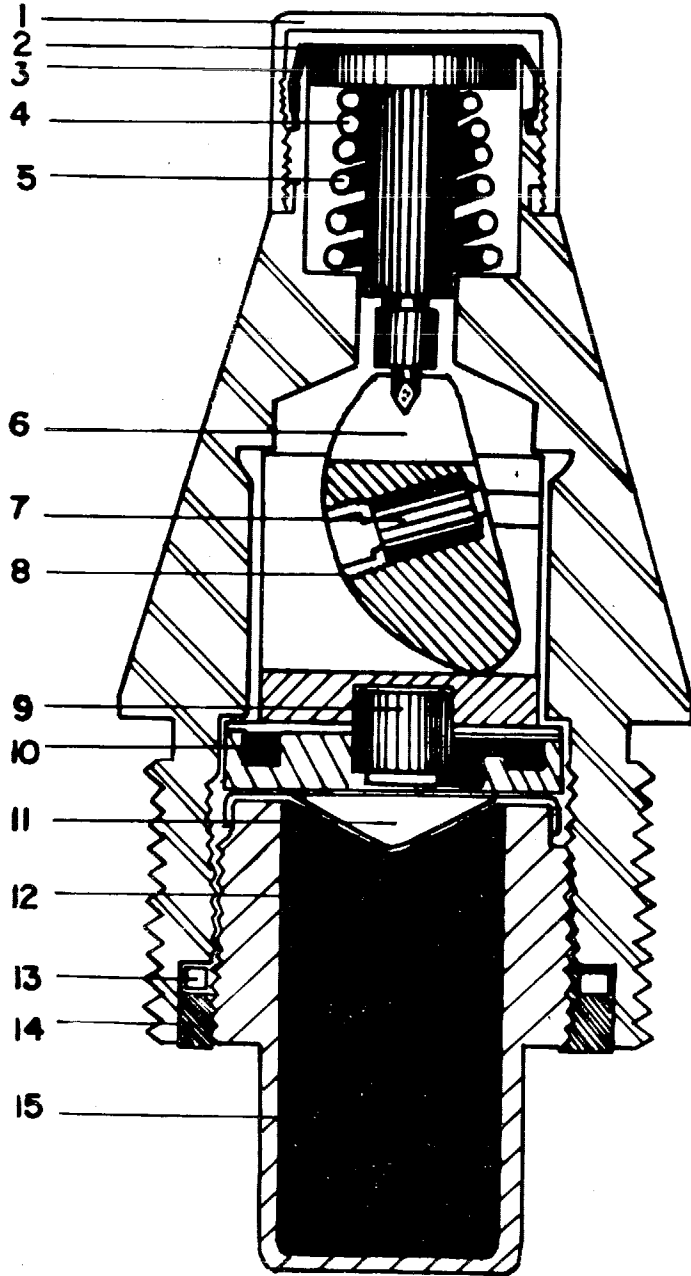

SOVIET POINT DETONATING IMPACT FUZE MODEL 192-57

CHAPTER 2

CHINESE COMMUNIST FUZES FOR AIRCRAFT AND ANTI-AIRCRAFT GUNS

2-1.1

## GENERAL

ChiCom Aircraft and Anti-Aircraft fuzes appear to be exact copies of their Soviet counterparts. In most instances, materials, workmanship, and components are identical. ChiCom fuzes are designated by the Chinese character suffix for "Type". The prefix character normally represents a Chinese character which is similar to the sound of the Russian letter of the model designation. These Chinese characters and the Arabic number for the fuze type are die stamped into the fuze metal in the same manner as employed on Soviet fuzes.

CHICOM POINT DETONATING IMPACT FUZE TYPE 37

a. General. The ChiCom Type 37 is identical to the Soviet B-37 Point Detonating Impact Fuze.

b. Characteristics.

Action ----- Instantaneous

Loaded weight ----- 172 grains (0.38 lbs)

Body material ----- steel

c. Functioning. The functioning of this fuze is identical to the workings of the Soviet B-37 and MG-37 Point Detonating Impact Fuzes.

d. Weapons and projectiles with which used.

37-mm Anti-Aircraft Gun Type ?

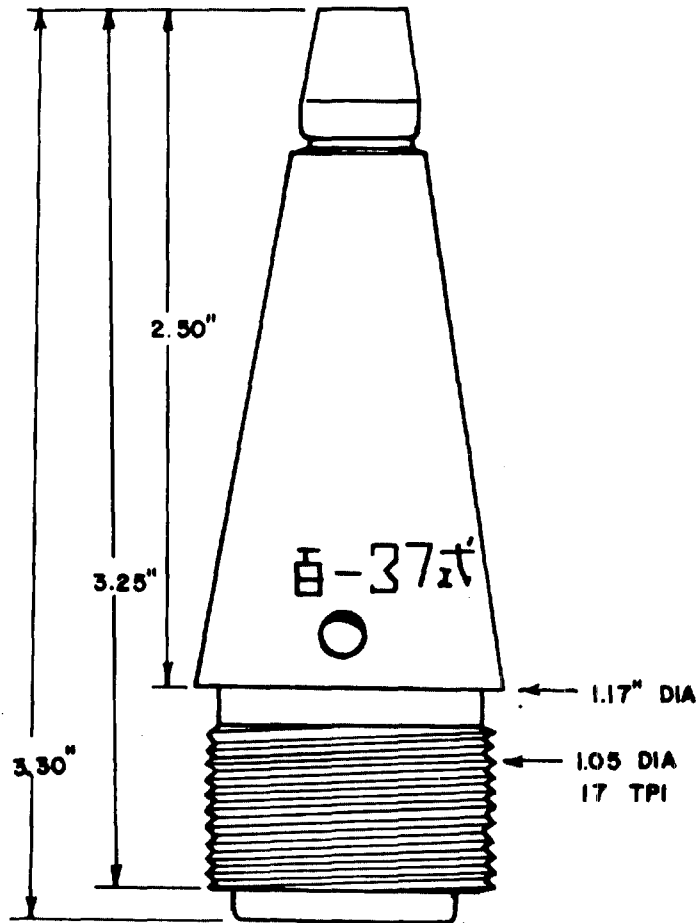

CHAPTER 3  
SOVIET POINT DETONATING FUZES

3-1.1

## SOVIET POINT DETONATING FUZES

Early Soviet fuze designs were based on principles seen in French Schneider Fuzes. The Schneider Company built and operated cannon and projectile manufacturing plants in Tzarist Russia and, quite naturally, exerted a great influence in early Russian artillery thinking. When the Soviet gained control of Russia, after the Russian Revolution in 1917, the French Schneider plants fell under their control. Even though these heavy industrial facilities were completely Sovietized they continued to exert French influence on Soviet artillery munition designs. This condition continued until World War II when German munition philosophies severely modified the original French influence.

Today, basic fuze principles originating in all the major munition producing countries of the world may be seen in Soviet Fuzes. It is quite evident that the Soviet espionage apparatus collected the data and Soviet ordnance engineers incorporated the most desirable features into current designs. Because of this, current Soviet designs show a marked improvement in safety, reliability and workmanship. The most notable improvement is seen in environment proofing. Soviet fuzes, with some minor exceptions, are completely waterproof. It was learned, much to the consternation of Free World Forces, that the Viet Cong and North Vietnamese Army stored Soviet fuzes, rockets and some other ammunition items underwater, as a normal procedure. With all these factors married together, Soviet point detonating fuzes exhibit completely indigenous characteristics and, in a reverse pattern, influence western fuze design philosophies.

The Soviet classify fuzes in two major categories. Literally translated, they are "igniferous" and "disruptive". Igniferous" fuzes (Trubki) contain low explosives and serve as initiators to produce functioning of expelling charges, detonators and detonator-booster combinations. "Disruptive" fuzes (Vzryvalety) contain a stab sensitive detonator, or detonator-booster assembly and are intended to initiate direct functioning only in high explosive-fragmentation or high explosive-armor piercing ammunition.

The two major Soviet fuze classifications are further subdivided into classes that are directly comparable to their American counterparts. These are point detonating fuzes, and base detonating fuzes. The type of functioning action is a basis for a further division into impact, combination time and impact, time and proximity fuzes. Fuzes of the impact type are armed by set-back, centrifugal force, or a combination of both, and function by direct action upon impact with a target. Some incorporate selective instantaneous or delay features.

The degree of safety in handling and firing forms the basis of an additional Soviet fuze classification. "Unsecured" fuzes are unsafe in handling or firing. In this class, the primer and detonator are not shielded or separated from booster. "Semisecure" fuzes are safe for transport, but are not detonator safe. In this class the primer is isolated from the detonator, but the detonator has free access to the

booster. "Safe" fuzes are bore and detonator safe. Newly adopted Soviet fuzes show a marked increase in out-of-line detonator designs indicating a positive trend toward eliminating all but "safe" fuzes.

Soviet artillery fuzes are of conventional design and function on accepted mechanical and explosive principles. Point detonating fuzes are constructed from a wide range of materials. The major proportion of Soviet fuzes have components of steel and are exceedingly robust in design. All point detonating fuzes incorporating selective instantaneous and delay features are of steel and are designed to remain intact and in line even though the fuze may have impacted against a solid target. Fuzes employed in point initiating-base detonating modes are normally made of aluminum. This materiel has proven sufficiently rigid to maintain high explosive-anti tank projectiles at a proper stand-off for maximum penetration. Fuzes which function instantaneously are being constructed of plastic. Urea formaldehyde with a cellulose filler is the most common plastic encountered. Since these fuzes are not required to withstand impact stresses, a molded plastic offers an economical medium from which to mass produce fuze bodies.

Point detonating fuzes are generally equipped with a removable nose cap. For instantaneous fuze action, the cap is removed before firing. If a slight delay is desired (non-delay) the fuze is fired with the cap in place. Soviet fuze terminology defines a delay fuze as one whose functioning delay is 0.01 second or greater. The United States definition is 0.02 second or greater.

The Soviet have apparently abandoned black powder delay pellets as being inconsistent with their environment-proof munition design philosophy. Black powder is notoriously hygroscopic. For this reason, non-hygroscopic, non-gaseous compounds are currently being pressed into delay pellets.

Soviet fuze markings are die-stamped into fuze bodies on or near the greatest diameter. The markings normally consist of a single line of cyrillic letters and arabic numbers. The line of markings is separated, by dashes, into groups which identify the manufacturing plant, fuze designation, lot number and year of manufacture. Sometimes, these markings are found at random locations and may be stenciled rather than die-stamped.

Certain fuzes have different colored nose caps or colored bands around the membrane caps. These markings apparently are employed to identify fuzes which are identical in appearance, but which have different functioning action. Where the color coding is known, it is explained in the text.

The Soviet appear to have adopted the principle of dual fuze action in their point detonating fuzes. Basically, this fuze design philosophy utilizes the principle of forcing a firing pin rearward upon impact, while simultaneously, the primer-detonator moves forward by inertia. To increase the sensitivity of inertial actuated primer-detonator carriers, graze-sensitive cam weights are employed to cam

the carrier forward on impact at flat angles. This principle is commendable and appears to have resulted in great fuze reliability.

SOVIET POINT DETONATING IMPACT FUZE MODEL AD

a. General. The AD fuze is a copy of an old French fuze. It is used with 76-mm and 152-mm high-explosive projectiles of French design, and is made of old French parts. It is a double-action type and has two settings: instantaneous and nondelay. If the fuze cap is removed, the action is instantaneous; with cap on, a nondelay action is obtained.

b. Characteristics.

Action ----- instantaneous and nondelay

Loaded weight ----- 150 gm. (0.33 lb.)

Body material ----- brass

c. Functioning. Upon firing, the stirrup (4) sets back, overriding the primer carrier (6), and compressing the stirrup safety spring (11). The stirrup clips (5) engage the step on the inner circumference of the stirrup, thereby locking the primer carrier to the stirrup. Simultaneously, the primer carrier sets back, firmly pressing the lead gas check ring (7) against the base plug, and the stud on the base of the primer carrier enters the hole in the base plug, effectively sealing off the detonator (8) from the primer (12); this prevents the fuze from detonating in the weapon, should premature ignition of the primer occur. After the projectile leaves the bore, the stirrup safety spring (11) decompresses and moves the stirrup, with the attached primer carrier, forward into position directly beneath the firing pin (3). Upon impact, at the instantaneous setting (fuze cap (1) removed), the striker (10) and firing pin are driven rearward, overcoming the firing pin spring (2). The firing pin strikes the primer, successively initiating the primer, detonator, and booster (9), thus exploding the shell. At the nondelay setting (fuze cap (1) left in place), the fuze cap (1) prevents the movement of striker and firing pin; instead, the primer carrier sets forward at impact, forcing the primer against the firing pin, and in this way initiating the explosive train.

d. Weapons and projectiles with which used.

	Weapons	Projectiles
76-mm:	divisional guns M1902/30, M1933, M1936 (F-22), M1938/39, M1939, (USV), and ,1942 (ZIS-3); regimental gun (howitzer) M1927; tank gun M1927/32	76-mm HE ----- F-354F
152-mm:	howitzer M1909/30	152-mm HE ----- F-533F

SOVIET POINT DETONATING IMPACT FUZE MODEL AD

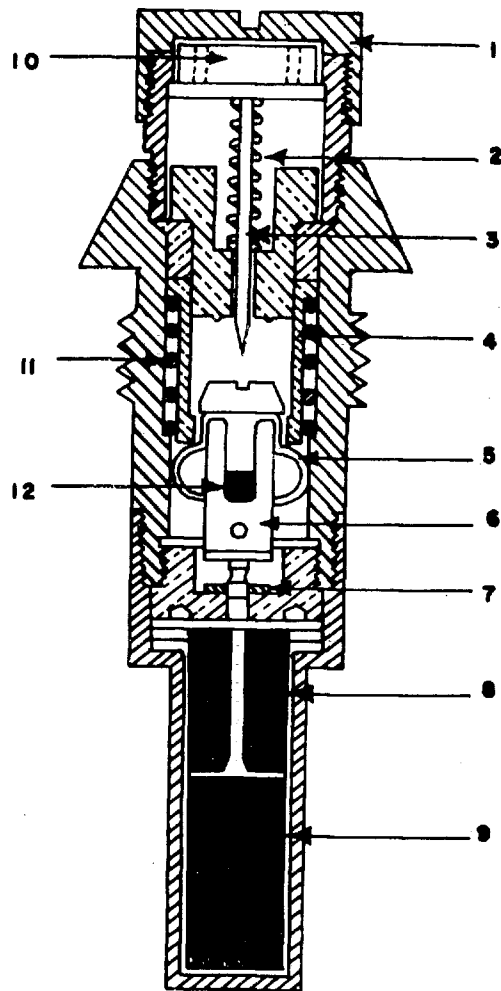
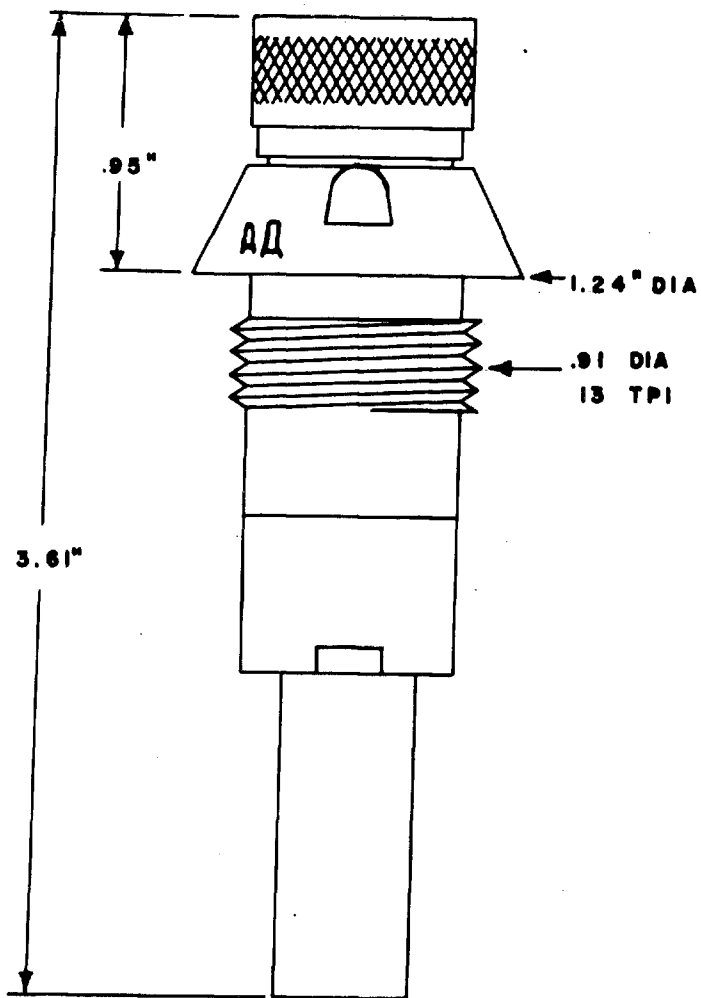

SOVIET POINT DETONATING IMPACT FUZE MODEL AD-2

a. General. This fuze is similar in construction, action, and settings to the Model AD, and differs from the AD fuze only in the shape of the nose. The AD-2 fuze is a copy of the French point detonating fuze Mark 24/31 of the 1899/16 design and is interchangeable with the AD.

b. Weapons and projectiles with which used.

Weapons	Projectiles
76-mm: divisional guns M1902/30, M1936 (F-22), M1939(USV), and M1942 (ZIS-3); regimental gun (howitzer) M1927; tank gun M1927/32	76-mm HE ----- F-354F
152-mm: howitzer M1909/30	152-mm HE F-533F

SOVIET POINT DETONATING IMPACT FUZE MODEL AD-N

a. General. The AD-N is similar in construction, action, and settings to the AD and AD-2 fuzes and differs significantly from them only in that it is assembled not from remade or salvaged parts, but from newly manufactured components. It is interchangeable with the AD and AD-2 fuzes.

b. Weapons and projectiles with which used.

Weapons	Projectiles
76-mm: divisional guns M1902/30, M1936 (F-22), M1939(USV), and M1942 (ZIS-3); regimental gun (how) M1927; tank gun M1927/32	76-mm HE ----- F-354F
152-mm: howitzer M1909/30	152-mm HE ----- F-533F

SOVIET POINT DETONATING IMPACT FUZE MODEL BM

a. General. The BM fuze was designed for use with HEAT ammunition. Its main components are a body, an arming mechanism, a direct-action percussion mechanism, and a detonator assembly. The striker (2) is made of a light alloy and has a head of large sectional area, thereby insuring high sensitivity on impact. Although the fuze is apparently safe to handle and fire, its Soviet safety classification is "unsecured".

b. Characteristics.

Action ----- Instantaneous

Loaded weight ----- ?

Body material ----- Steel

c. Functioning. Upon firing, the arming sleeve (4) sets back and compresses the arming sleeve spring (5), whereupon the arming sleeve retaining balls (11) fall away. When the projectile leaves the bore of the gun, the arming sleeve spring decompresses, thereby moving the arming sleeve forward until the firing pin retaining balls (6) are released from their housings in the firing pin guide (3); the release of the firing pin retaining balls frees the striker (2) and firing pin (7) for rearward movement. Impact drives the striker and firing pin rearward, so that the firing pin pierces the brass foil safety disk (8) and penetrates the detonator assembly (10), which explodes, activating the projectile.

d. Weapons and projectiles with which used.

	Weapons	Projectiles
76-mm:	divisional guns M1902/30, M1933, M1936 (F-22), M1938/39, M1939 (USV), and M1942 (ZIS-3); regimental guns (howitzers) M1927 and M1943; tank gun M1927/32	76-mm HEAT BP-344A; BP-350M; BP-353A; BP-353AM; BP-354AM

SOVIET POINT DETONATING IMPACT FUZE MODEL BM

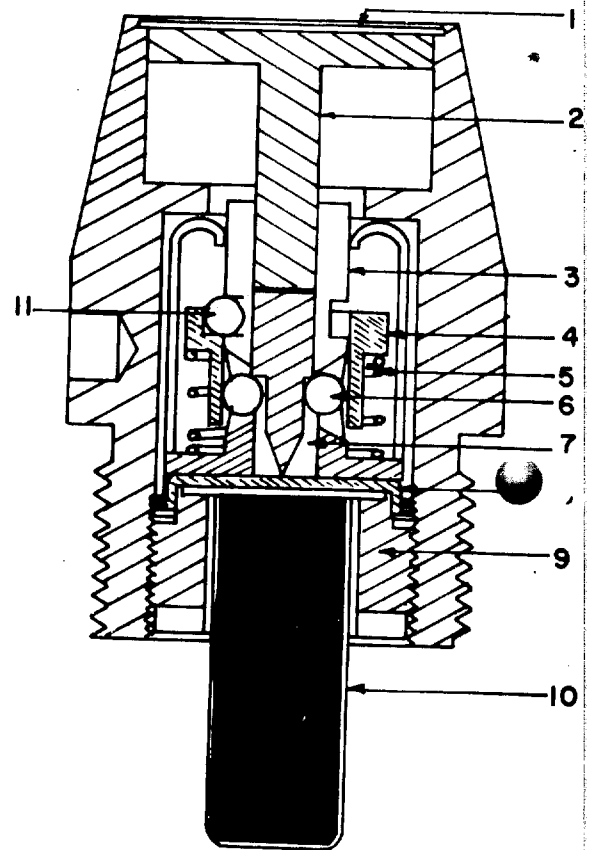
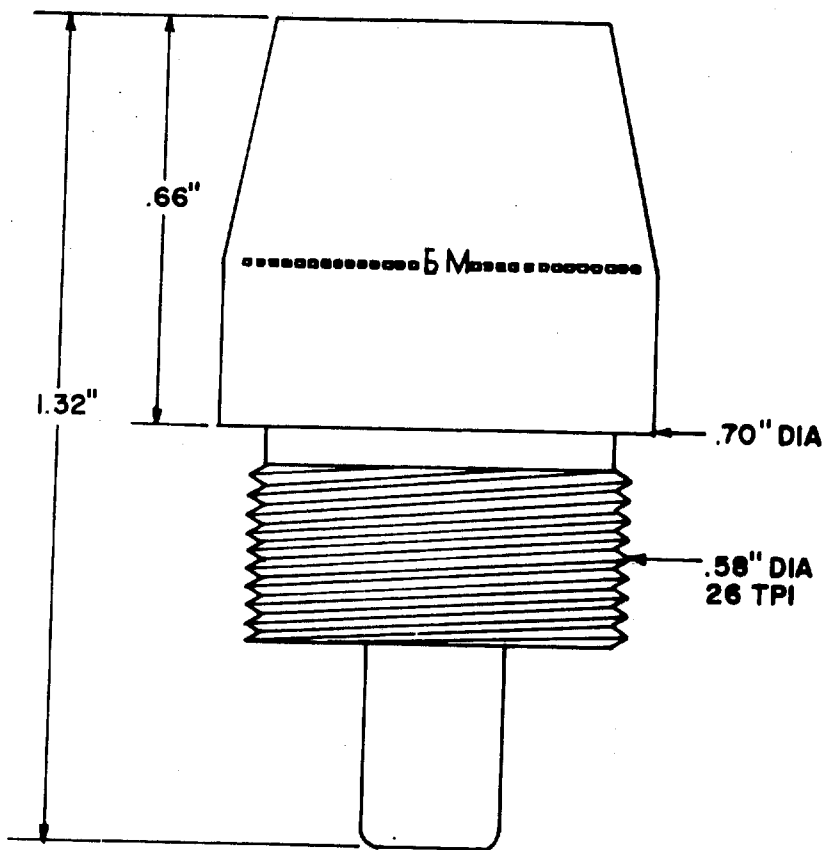

## SOVIET POINT DETONATING IMPACT FUZE DKZ-B

a. General. The Soviet DKZ-B point detonating fuze has been encountered only on the 122-mm fin-spin stabilized rocket DKZ-66. All fuzes recovered have been sanitized. The only marking exhibited on the fuze is the lot number.

The DKZ-B is unique in that the fuze body is of composite construction. It has an outer urea formaldehyde plastic sheath (16) bonded to the inner steel body (15). The DKZ-B is longer and heavier than standard Soviet fuzes. However, it displays the usual Soviet effort toward waterproofness. All openings are sealed with a synthetic rubber compound (2) that renders the fuze completely waterproof. The selection spindal (27) is sealed by a packing gland and nut (34).

The DKZ-B is constructed of four major subassemblies: A nose cap (1) and membrane crimped to the aluminum windshield (21); the aluminum windshield containing the urea formaldehyde plastic arming mechanism housing (23); the plastic bonded steel body (15) containing the selection spindal (27) and three delay elements (17). The steel booster cup (28) containing the relay detonator (19) pressed into the booster charge (20). Two of the delay elements (17) are for short delay "B" setting and are redundant. The third and longer delay element (29) is for long delay.

The ogive (21) is unpainted, but has a thin coat of varnish. Except for the plastic (16) the fuze body and booster cup (28) are black and possess a protective varnish coating. The plastic (16) has been seen painted both blue and black, with blue predominating. The lot number is die stamped near the base of the ogive.

The arming mechanism (23) is setback operated and employs a Zig-Zag slot governor for arming delay. The arming mechanism (23) releases the cocked arming primer (8) that initiates a pyrotechnic delay arming pellet (13) that unlocks the detonator rotor (25). The single purpose of the arming mechanism (23) is to release the primer (8). The pyrotechnic delay arming mechanism (14) consists of a pressed, non-gaseous powder (13) blocking a detent (14), which in turn locks the detonator rotor (25) in the safe position. When the pyrotechnic element (13) is consumed, cam action from the spring loaded detonator rotor (25) forces the detent (14) into the evacuated cavity, unlocking the rotor (25). An acceleration weight (30), is setback upon launch against its spring (31) and also unlocks the rotor (25). Without sustained acceleration locking the weight (30) down until after the delay arming detent (14) is withdrawn, the fuze will not arm.

The selection spindal (27) controls the instantaneous "C", short delay "B" and long delay "M" functioning of the fuze. On instantaneous, a straight through flash channel (32) permits flame from the detonator (26) in the rotor (25) to flash directly into the relay detonator (14). On short delay, the spindal (27) presents a solid block in the flash channel (32) so that the short delay pellets are ignited by flame that is reflected upward and outward by the blocked flash channel (32). On long delay, the spindal (27) has a short longitudinal channel (33) that leads flame to the

SOVIET POINT DEMONSTRATING IMPACT FUZE DKZ-B

long delay pellet (29). Functioning of either one or both of the short delay pellets (17) or the single long delay pellet (29) produce flame from their respective flash pellets (18) which flashes directly into the heat sensitive relay detonator (19) in the booster (28).

b. Characteristics.

Action ----- Instantaneous or delay  
Loaded weight ----- 908 grams (2.0 lbs)  
Body material ----- Steel, aluminum and plastic

c. Functioning. When the DKZ-66 rocket is fired, setback causes the setback sleeve (22) to move rearward while being retarded by the Zig-Zag slot governor and the sleeve spring (4). When the setback sleeve reaches the bottom of its travel, two levers (5) are cammed inward, releasing the lock ball (6) which releases the spring loaded arming primer (8). The arming primer (8) propelled by its spring (7) impinges on the fired firing pin (10). The primer (8) flashes and flame travels through the three flash holes in the firing pin housing (10). This ignites the flash pellet (11) whose flame ignites the relay pellet (12). The relay pellet ignites the delay arming pellet (13). Simultaneously, setback and sustained acceleration cause the weight (30) to move to the rear and remain there partially unlocking the detonator rotor (25). When delay arming pellet (13) burns out, the locking detent (14) is cammed into the pellet cavity by the rotating rotor (25) powered by the rotor spring (35). The fuze is now armed. Upon impact, the nose cap membrane (1) is crushed so that the firing pin plunger (3) is forced downward driving the firing pin (9) downward against its spring into the detonator (26). If the spindal is set for instantaneous action, the straight through flash channel (32) permits flame from the detonator (26) to flash directly into the relay detonator (19) functioning the warhead. If the spindal is set for short delay, the flash channel is blocked and the delay pellets are ignited. When they burn through, the flash pellets flash into the detonator producing warhead functioning. If the spindal is set on long delay, the flash channel (33) transmits flame from the detonator to the long delay pellet (29). When the pellet burns out, the burn out flame completes fuze functioning.

d. Weapons and projectiles with which used.

Weapons	Projectiles
122-mm: rocket launcher Type ?	122-mm HE-PEFrag ----- 9M22M

SOVIET POINT DETONATING IMPACT FUZE DKZ-B

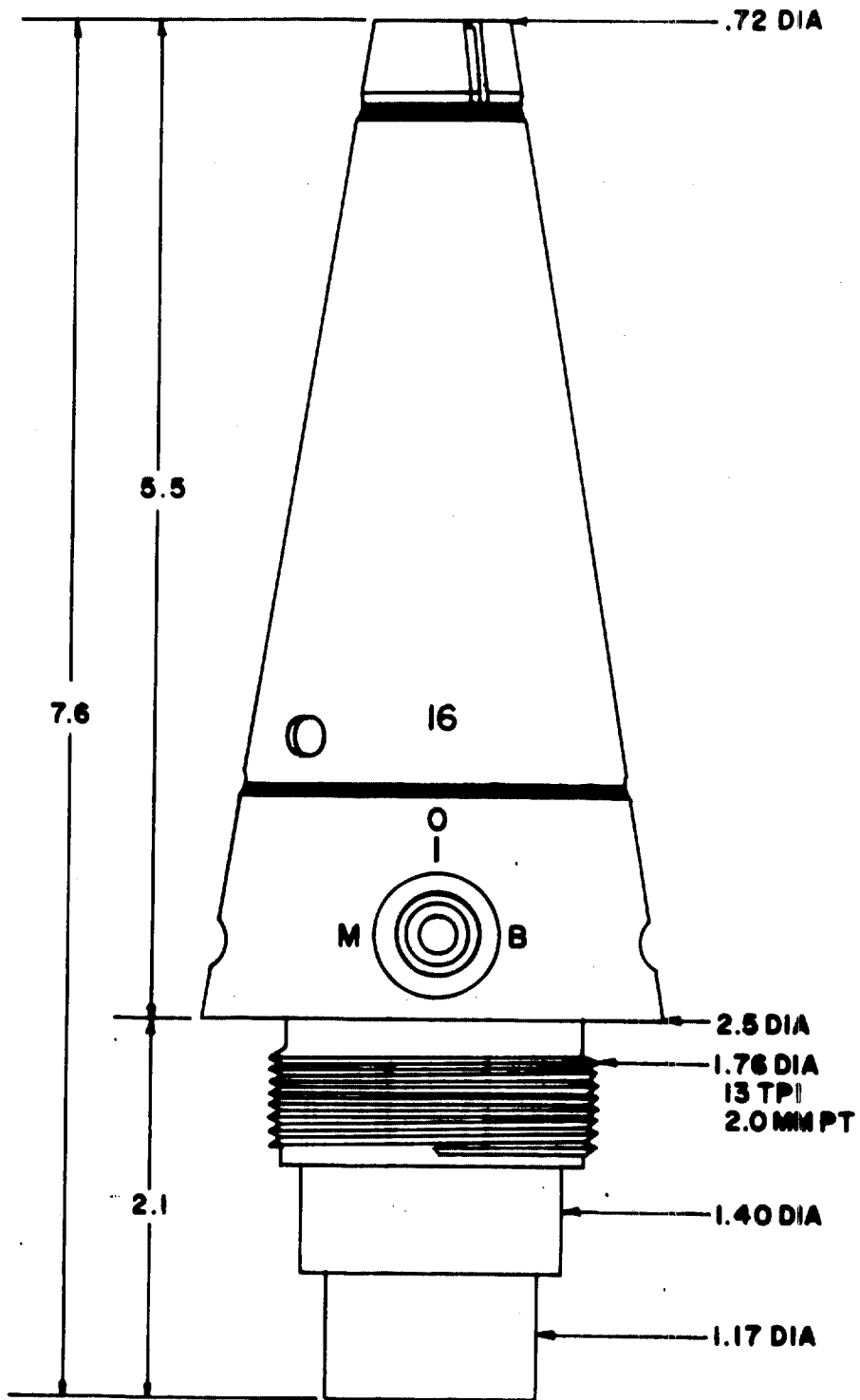

SOVIET POINT DETONATING IMPACT FUZE DKZ-B

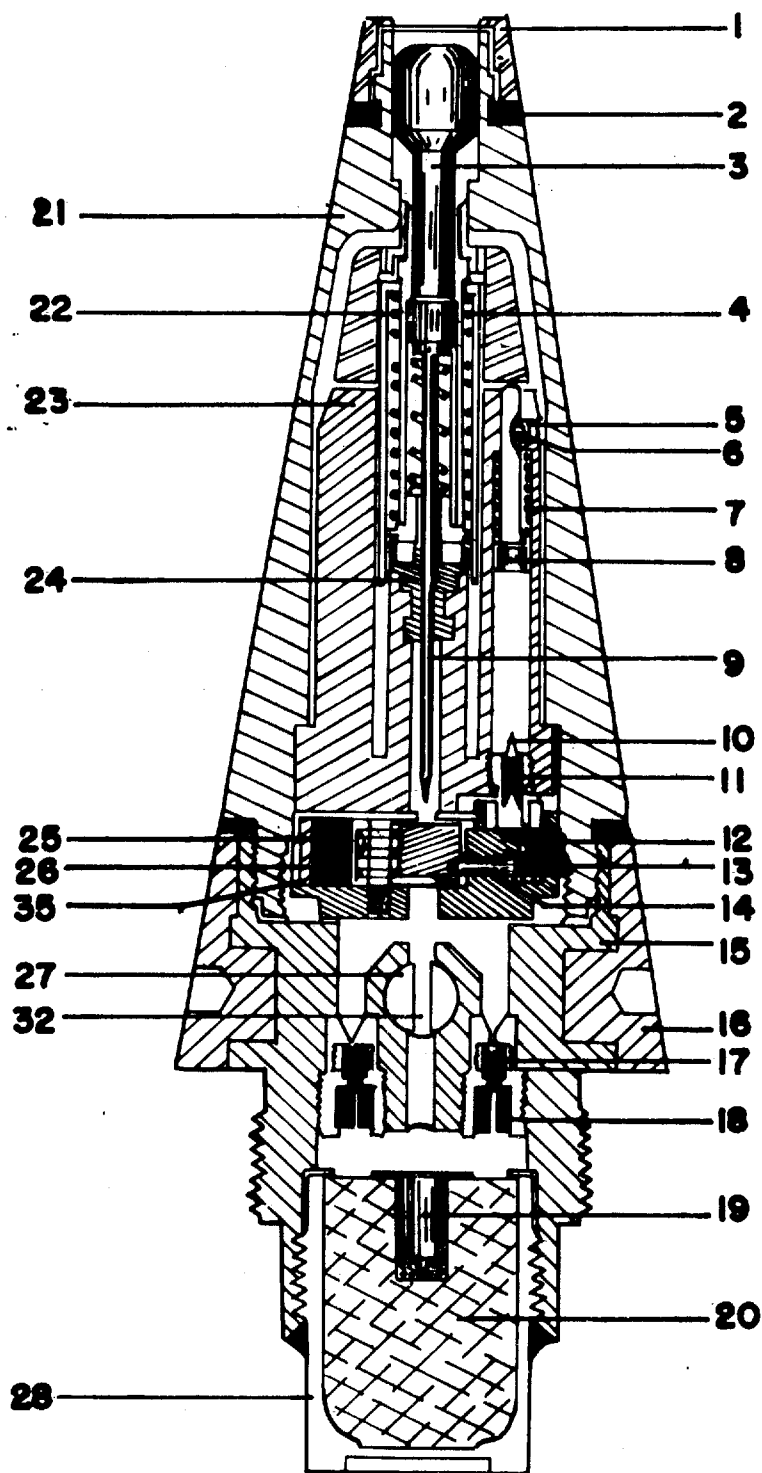

SOVIET POINT DETONATING IMPACT FUZE MODEL DKZ-B

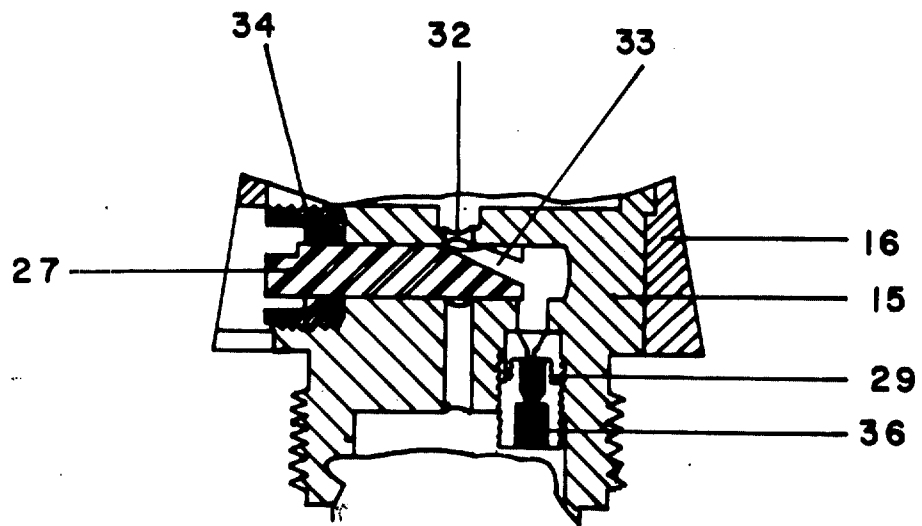
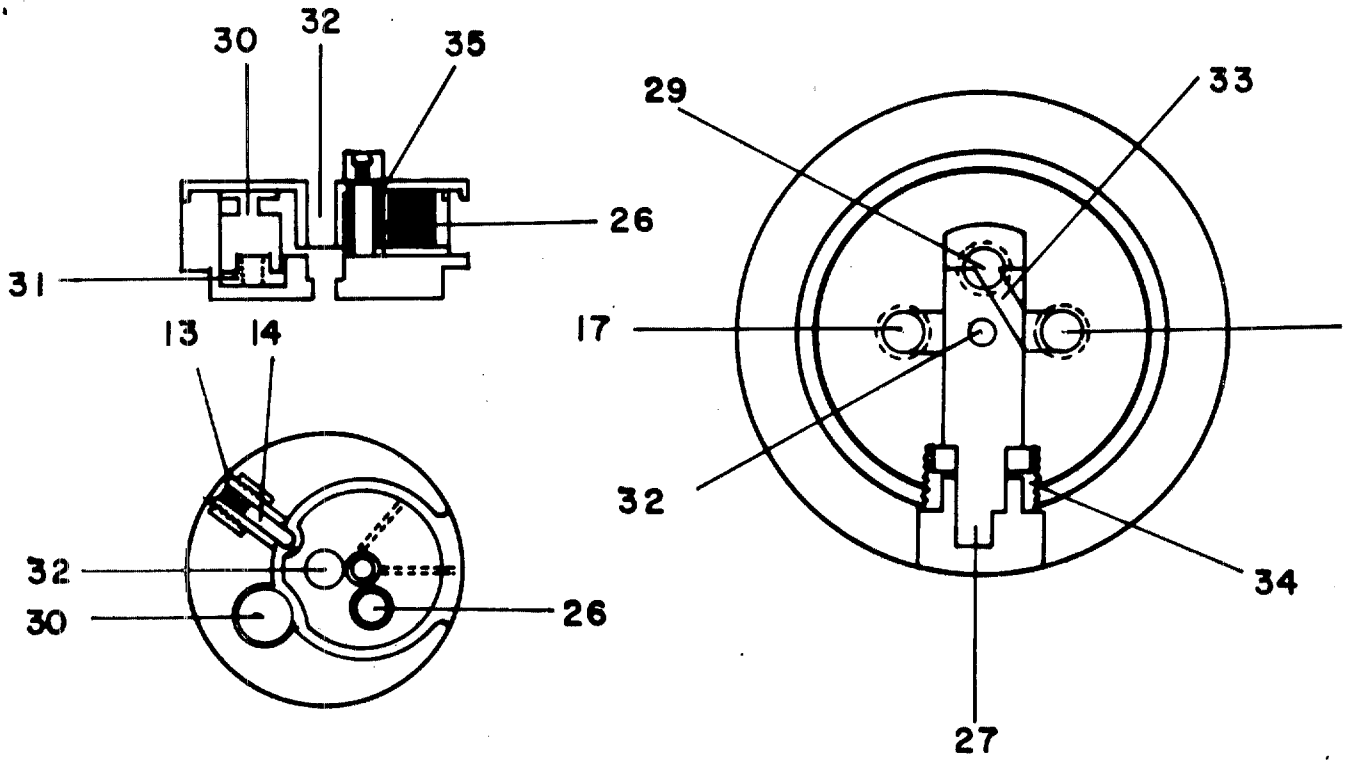

SOVIET POINT INITIATING BASE DETONATING IMPACT FUZE MODEL GK-1

a. General. The Soviet Model GK-1 fuze is a setback armed, nondelay, impact fuze. It was designed to be employed as a point initiating, base detonating fuze for use with high explosive antitank (HEAT) projectiles and as a straight impact fuze for use with high explosive fragmentation projectiles. The GK-1 is an extremely sensitive fuze, as are all of the GK series. The nose of the GK-1 is protected with a shipping cap which is removed prior to firing. Delayed arming is achieved by the use of a zig-zag slot cut in the setback sleeve (5). Because of the in-line explosive train the GK-1 is not detonator safe. Graze sensitivity is achieved through the use of a cam weight positioned in the bottom of the fuze. Any lateral impact causes the weight (12) to cam the primer carrier (7) up into the firing pin (3). The GK-1 is considered obsolete having been replaced by the GK-2 and GK-2M fuzes.

b. Characteristics.

Action ----- Instantaneous  
Loaded weight ----- 155 grams (0.34 lbs.)  
Body material ----- Aluminum

c. Functioning. Upon firing, setback causes the sleeve (5) to move to the rear, releasing the sleeve retaining ball (9), which falls into the fuze body cavity. As setback diminishes, the sleeve spring (4) forces the sleeve (5) to move forward to the head of the firing pin (3). This releases the four firing pin retaining balls (6) allowing them to fall into the fuze cavity. The fuze is now armed with the firing pin (3) separated from the primer (7) only by the expanded firing pin spring (11). Upon impact, the foil cap (1) and the firing pin plunger (2) are driven downward against the head of the firing pin (3), which in turn causes the firing pin to pierce the stab sensitive primer (7). This initiates the detonator (8) which causes the projectile to detonate. On graze impacts, the graze weight (12) moves laterally camming the primer carrier (7) onto the firing pin (3) producing functioning.

d. Weapons and projectiles with which used.

Weapons	Projectiles
82-mm: Soviet AT Rocket Launcher Model SPG-82	82-mm: HEAT----- FG-82

SOVIET POINT INITIATING BASE DETONATING IMPACT FUZE MODLL GK-1

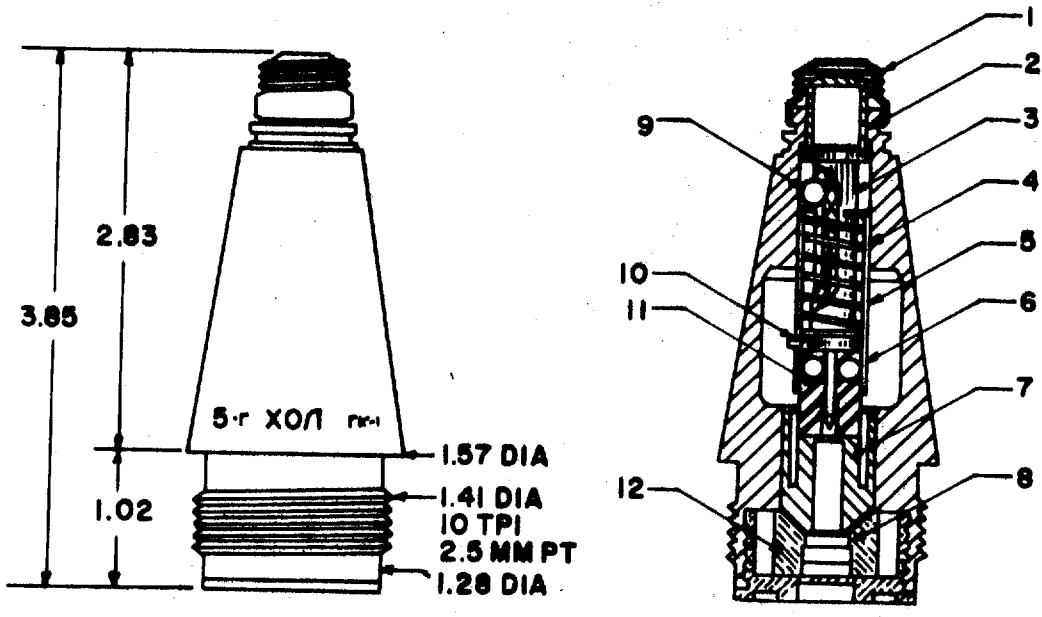

## SOVIET POINT DETONATING IMPACT FUZE MODEL GK-2

a. General. The GK-2 is similar in construction and functioning to the Soviet GK-1. The only noticeable difference between the GK-2 and GK-1 is the Zig-Zag delay arming assembly. This element provides a greater safe arming distance for the GK-2. The basic design for the GK-2 appeared in the Soviet M-50 mortar fuze and is almost identical with the current Soviet M-6 mortar fuze. Due to the in-line explosive train, the GK-2 is not considered detonator safe.

The GK-2 may be fired with or without the shipping cover in place. If the fuze is fired with the shipping cover a slight delay is inherent in functioning.

The GK-2 employs a graze sensitive feature to insure functioning at low angles of impact. The graze sensitive plunger or hammer resides in an enlarged cavity. Its concave surface rests against the conical surfaces of the primer detonator assembly. Any impact, other than one directly on the nose of the fuze, causes the graze hammer to move laterally, thereby forcing the primer-detonator forward through cam action.

### b. Characteristics.

Action ----- instantaneous

Loaded weight ----- 0.39 Lb.

Body material ----- Aluminium

c. Functioning. Upon firing, set back forces the Zig-Zag sleeve (15) to the rear, releasing the sleeve retaining ball (14) which falls into the fuze body cavity. As set back decreases the sleeve spring (4) which was compressed by the sleeve, expands, moving the sleeve (15) forward beneath the head of the firing pin assembly (13) and releasing the four firing pin locking balls (6), allowing them to drop into the fuze body cavity (5). The fuze is now armed. The firing pin is held separated from the primer detonator (9) by the firing pin spring (17). Upon impact, the plunger (2) is driven against the head of the firing pin assembly (13) which pierces the primer detonator (9) causing it to detonate and, in turn, detonate the booster.

If the fuze impacts at a flat angle so that the plunger (2) is not depressed, the graze sensitive plunger moves laterally, overcoming the retaining disc (11) and forcing the primer-detonator assembly (9) forward onto the firing pin (9) achieving detonation.

SOVIET POINT DETONATING IMPACT FUZE MODEL GK-2

d. Weapons and projectiles with which used.

Weapons  
 82-mm Recoiless Rifle  
 107-mm Recoiless Rifle

Projectiles  
 82-mm HE ----- O-881A  
 82-mm HEAT ----- BK-881  
 107-mm HE ----- OF-883A  
 107-mm HEAT ----- BK-883

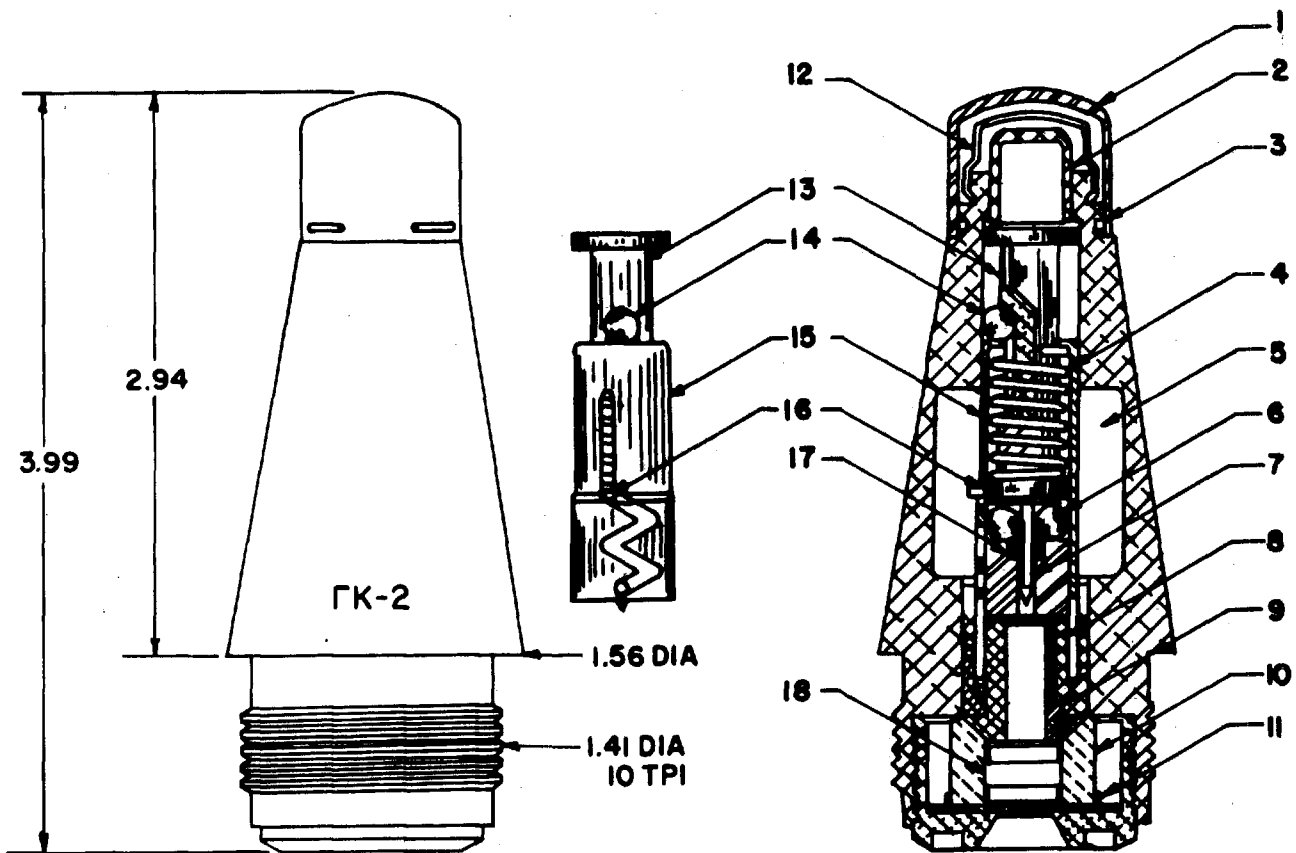

SOVIET POINT INITIATING IMPACT FUZE MODEL GK-2M

a. General. The Soviet GK-2M is a later version of the GK-1 and GK-2 Soviet fuzes. Two major modifications have been incorporated into the GK-2M to improve fuze reliability on graze impact. The firing pin, plunger and nose assemblies have been redesigned. It has a cone shaped plunger and cone shaped cavity in the nose. The second change consists of the addition of an adapter for the primer-detonator assembly. This adapter eliminated the inner body cavity to receive the firing pin locking balls after setback. The cavities were difficult to machine and have been eliminated in the GK-2M. In all other respects the GK-2M is identical with the earlier GK-2.

b. Characteristics.

Action ----- instantaneous

Loaded weight ----- 7.12 Oz.

Body material ----- Aluminium

c. Functioning. Upon firing, setback causes the Zig-Zag sleeve (5) to move to the rear releasing the sleeve retaining ball (3) which falls into the fuze body cavity (6). As setback forces decrease, the sleeve spring (4) which was compressed by the sleeve during setback, recoils, moving the sleeve (5) forward, releasing the four firing pin locking balls (8), allowing them to drop into the body cavity (6). The fuze is now armed, with the firing pin (2) being held away from the stab sensitive detonator (10) by the anti-creep spring. Upon impact, the cone shaped plunger (1) is driven against the firing pin assembly (2) which causes the firing pin to pierce the primer-detonator, detonating the booster. On low angles of impact, the graze impact feature causes the booster impact weight to move laterally overcoming the retainer washer (12), camming the primer-detonator assembly (10) forward into the firing pin (9) causing it to function. If the cone nose strikes at an angle and is crushed out of line with the plunger (2), the cone shaped cavity in the nose causes the plunger to cam downward against the firing pin head, causing it to function.

d. Weapons and projectiles with which used.

82-mm Recoiless Rifle B-10

82-mm HEAT ----- Bk-881M

SOVIET POINT INITIATING IMPACT FUZE MODEL GK-2M

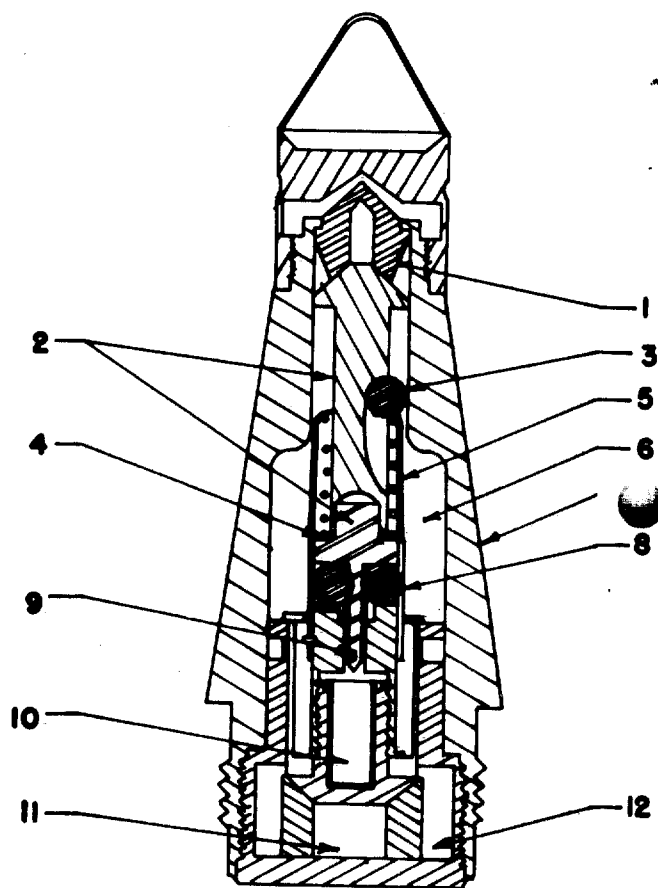
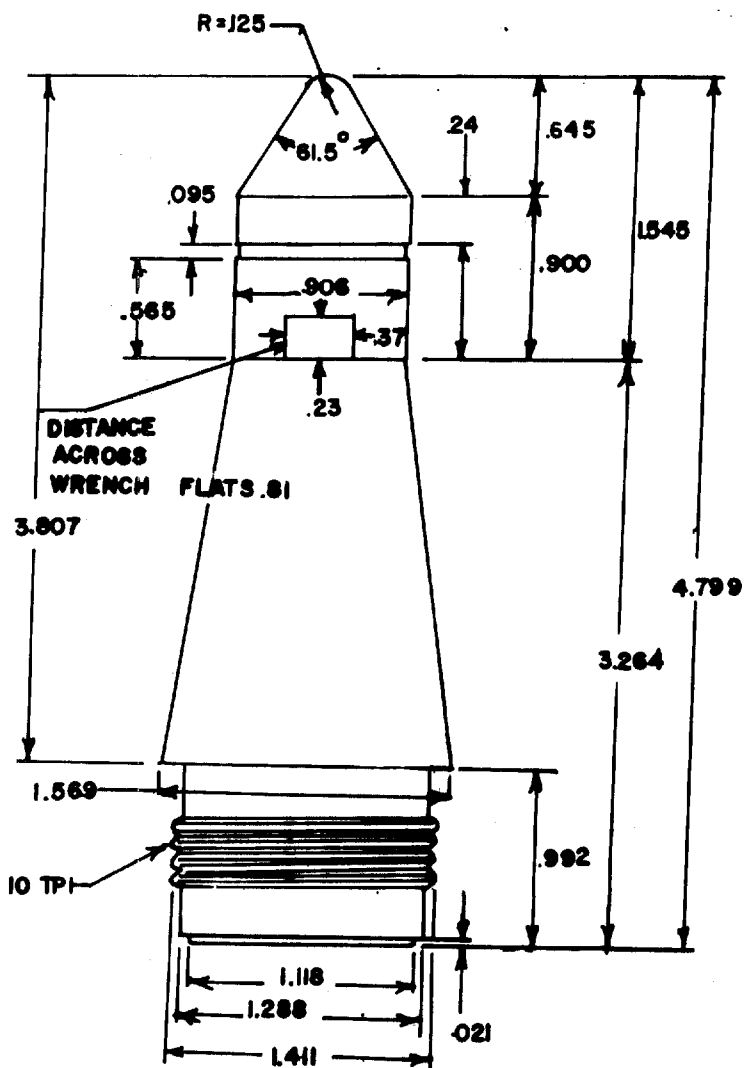

SOVIET POINT DETONATING IMPACT FUZE MODEL GVM

a. General. The GVM fuze differs from the GVMZ and the GVMZ-1 fuze inasmuch as it has no delay element and, consequently, no fuze setting device. It is an instantaneous fuze with one permanent setting. In other respects it is similar to the GVMZ and GVMZ-1. The GVM fuze is not being manufactured at the present time.

b. Weapons and projectiles with which used.

Weapons	Projectiles
120-mm: regimental mortars M1938 and M1943	120-mm Frag-HE --- OF-843, OF-843A Smoke ----- D-843A

SOVIET POINT DETONATING IMPACT FUZE MODEL GVMZ

a. General.

- (1) The GVMZ fuze was originally designed for 122-mm howitzer Frag-HE and Frag shells and 280-mm Frag shells; however, because of membrane ruptures and premature bursts when used for fire from howitzers, it was discontinued for use in gunfire. The weight of the powder delay element was reduced and the fuze was then used with 107-mm and 120-mm Frag-HE and smoke mortar shells. At present the GVMZ is used only with 120-mm Frag-HE mortar shells.
- (2) The GVMZ fuze is a departure from the usual Soviet fuze design in that it is termed a "thermo-pneumatic" fuze which operates on the "air column" principal of activating the initiating pellet rather than the conventional percussion striker. The air, trapped in a compression cup, is compressed to a density sufficient to generate enough heat to ignite an initiation pellet of black powder, lead azide, etc. No mechanical boresafety is incorporated in its design, but its principle of operation makes it boresafe under normal operating conditions (at low velocities). The safety cap (1) must be removed prior to firing the fuze. The settings for the GVMZ are as follows:

<u>Setting</u>	<u>Action</u>
"0"	instantaneous
"3"	delay (0.05 - 0.09 sec.)

b. Characteristics.

Action ----- instantaneous and delay  
Loaded weight ----- 430 gm. (0.946 lb.)  
Body material ----- steel

c. Functioning. On firing, no movement of the component parts takes place until the projectile strikes the ground. Upon impact when the fuze is set for instantaneous action, the nose bushing and diaphragm (8) are driven inward, and in turn, drive the compression plug (2) rearward, compressing the air in the compression cup (9) to a point where a sufficient heat is generated to ignite the black powder initiating pellet (3). The flame jet travels down the flash channel (5), through the transverse hole in the setting selector (4), and sets off the

SOVIET POINT DETONATING IMPACT FUZE MODEL GVMZ

detonator pellet (6), which detonates the booster (7). When set for delay action, the flame jet travels through a longitudinally drilled hole in the setting selector (4), down the delay channel (10) to the delay pellet (11), and sets off the detonator pellet (6), which in turn detonates the booster (7).

d. Weapons and projectiles with which used.

Weapons	Projectiles
107-mm: Mountain-pack regimental mortar M1938	107-mm Frag-HE ----- OF-841; OF-841A OF-841T Smoke ----- D-841
120-mm: Regimental mortars M1938 and M1943	120-mm HE ----- F-843 Frag-HE -- OF-843; Of-843A Smoke ----- OF- 843A

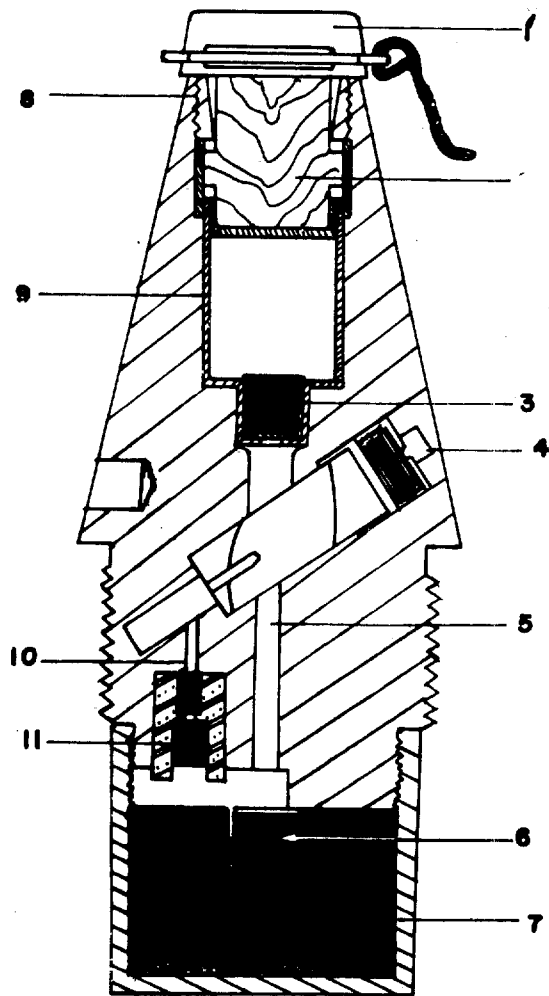
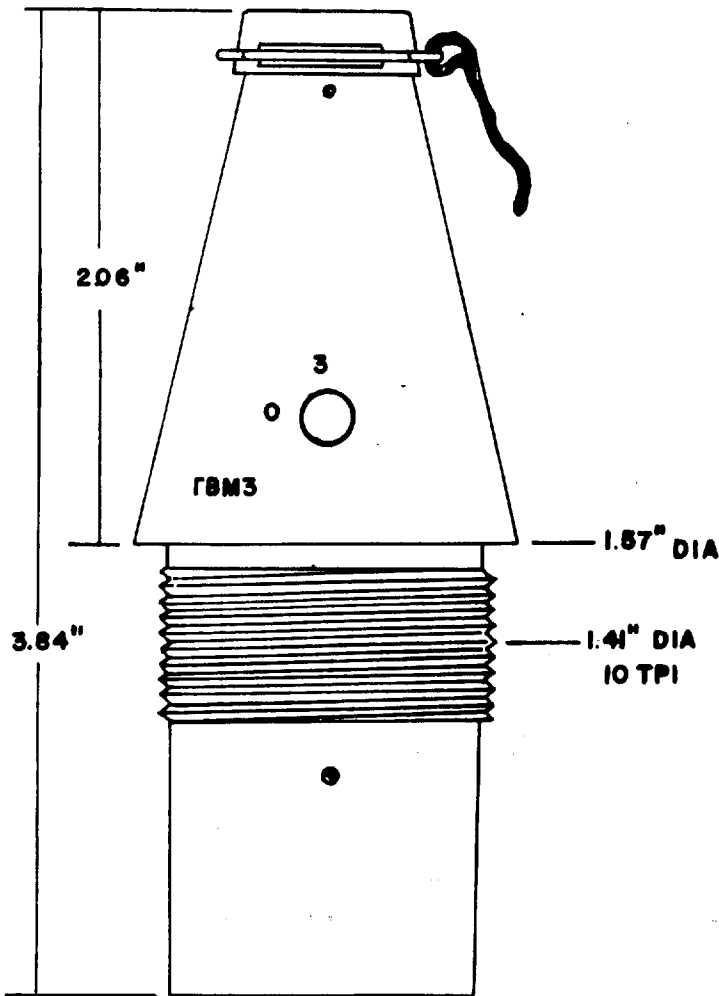

SOVIET POINT DETONATING IMPACT FUZE MODEL GVMZ-1

This fuze is similar in construction and functioning to the GVZM fuze, but has a simplified percussion mechanism with a wooden striker and a copper membrane. The clogging of powder between the delay element and the detonating cap is rendered impossible. Like the GVMZ, the GVMZ-1 fuze also has two settings: instantaneous (device set on "0") and delay (device set on "3"). It is used in the same projectiles and fired from the same weapons as the GVMZ.

3-23/3-24

SOVIET POINT DETONATING IMPACT FUZE MODEL GVMZ-7

a. General. The GVMZ-7 is a point detonating fuze used in the 107-mm and 120-mm mortars and 122-mm and 152-mm howitzers. This fuze is safe to transport and is boresafe. The fuze is prepared for firing by removing the shipping cap, pulling the safety cap retaining wire out of the cloth tab, and removing the safety cap (5). The fuze has settings for either delay or instantaneous action, as indicated below:

<u>Setting</u>	<u>Action</u>
"0" -----	instantaneous
"3" -----	delay

b. Characteristics.

Action ----- delay and instantaneous

Loaded weight ----- ?

Body material ----- steel

c. Functioning.

(1) On firing, setback causes firing pin (8) to be driven into safety powder pellet (10). The flame from the safety powder pellet passes through the grooves in the firing pin and ignites the black powder pellet (3). After the black powder pellet has burned, it allows a centrifugal segment (2) to move outward, which then allows the interrupter (7) to move outward through either one or both flash channels, depending on the setting.

(2) On impact with the target, the piston (1) is driven rearward compressing the air which ignites the primer (6). The flash from the primer then passes directly to the detonator (14) via the instantaneous flash channel (9), or to the delay pellet (13), depending on the setting. Setting "3" allows the interrupter (7) to move only far enough to uncover the delay flash channel (12), forcing the flash from the primer to ignite the delay pellet (13) which activates the detonator (14), and in turn the booster (4). Setting "0" allows the interrupter to move over far enough to uncover both flash channels so that the flash from the primer will pass directly to the detonator (14) and booster (4), resulting in instantaneous action.

SOVIET POINT DETONATING IMPACT FUZE MODEL GVMZ-7

d. Weapons and projectiles with which used.

Weapons	Projectiles
107-mm: mountain-pack regimental mortar M1938	107-mm ----- ?
120-mm: regimental mortars M1938 and M1943	120-mm ----- F-843
122-mm: howitzer M1938 (M-30)	122-mm ----- ?
152-mm: howitzer M1938 (M-10) and M1943 (D-1)	152-mm ----- ?

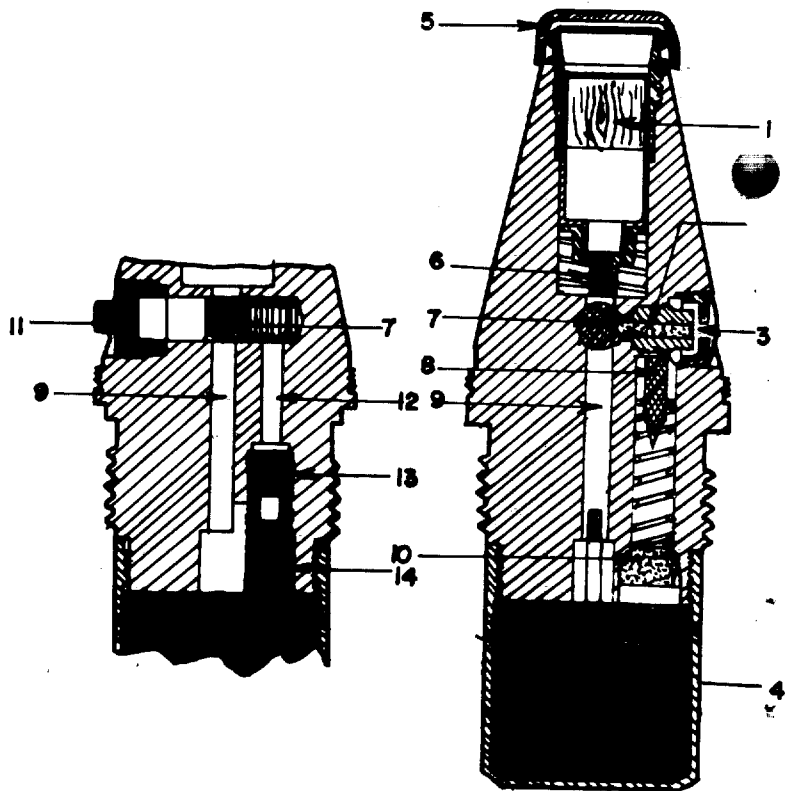
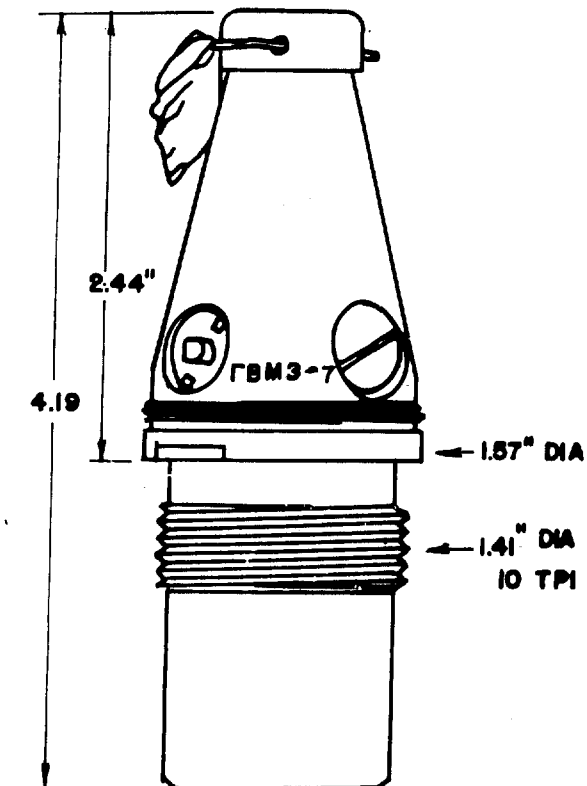

SOVIET POINT DETONATING IMPACT FUZE MODEL KT-1

a. General. The KT-1 is a point detonating, setback-armed fuze used with Frag and Frag-HE projectiles of 45-mm, 57-mm, and 76-mm caliber sizes. The Soviets refer to this fuze as "semisecure" and boresafe. The fuze is capable of nondelay and delay action depending on the use of the fuze cap and the compressed black powder delay pellet (10) which is sometimes inserted in this fuze for special demolition purposes. Fuzes containing the delay pellet are painted black; models without the delay pellet are painted light gray. The fuze action is regulated as indicated below:

<u>Fuze color</u>	<u>Action</u>
Black, w/delay element and cap	Long delay
w/delay element, w/o cap	Short delay
w/o delay element and cap	Instantaneous
w/o delay element, w/cap	Short delay
Light gray, w/o delay element and cap	Instantaneous
w/o delay element, w/cap	Short delay
Black nose only, w/delay element and cap	Long delay
w/delay element, w/o cap	Short delay

b. Characteristics.

Action ----- delay and nondelay  
Loaded weight ----- 370 gm. (.814 lb.)  
Body material ----- steel

c. Functioning. When the KT-1 fuze is set for instantaneous action (nose cap removed), the fuze functions as follows: Setback causes the stirrup (7) to compress the spring (6), override, and lock itself to the primer carrier (8). The primer carrier is also setback and compresses sealing washer (9) over the vent in the body, shielding the detonator (11) from the primer (5) should premature ignition occur. The striker (1) and firing pin (3) are also set back, but the firing pin does not reach the primer. After the projectile leaves the bore, the spring (6) raises the primer carrier (8) and stirrup (7) to a position directly

SOVIET POINT DETONATING IMPACT FUZE MODEL KT-1

under the firing pin (3). At the same time, the spring (2) returns the firing pin (3) and the striker (1) to their original positions. On impact, the striker (1) is driven rearward, forcing the firing pin (3) into the primer (5) which successively sets off the primer, the detonator (11), the booster (12). When the fuze is set for delayed action (nose cap in place), the action is identical to that of instantaneous action except that on impact the cap prevents the striker (1) and the firing pin (3) from being driven rearward. At the same time, inertia drives the primer carrier (8) forward, forcing open the segmented safety shutter (4) and driving the primer (5) against the firing pin to activate the explosive train.

d. Weapons and projectiles with which used.

Weapons	Projectiles
45-mm:	
45-mm: antitank guns M1932, M1937, and M1942; tank guns M1932 and M1934	45-mm Frag ----- 0-240
57-mm: antitank guns M1941 and M1943	57-mm Frag ----- 0-270;0-271
76-mm: tank guns M1927/32, M1938/39 (L-11), M1939 (F-32), M1940 (F-34), and M1941 (ZIS-5); divisional guns M1902/30, M1933, M1936 (F-22), M1939 (USV), and M1942 (ZIS-3); regimental guns (howitzers) M1927 and M1943; mountain guns (howitzers) M1909 and M1938	76-mm Frag-HE -- OF-343; OF-350; OF-350A

SOVIET POINT DETONATING IMPACT FUZE MODEL KT-1

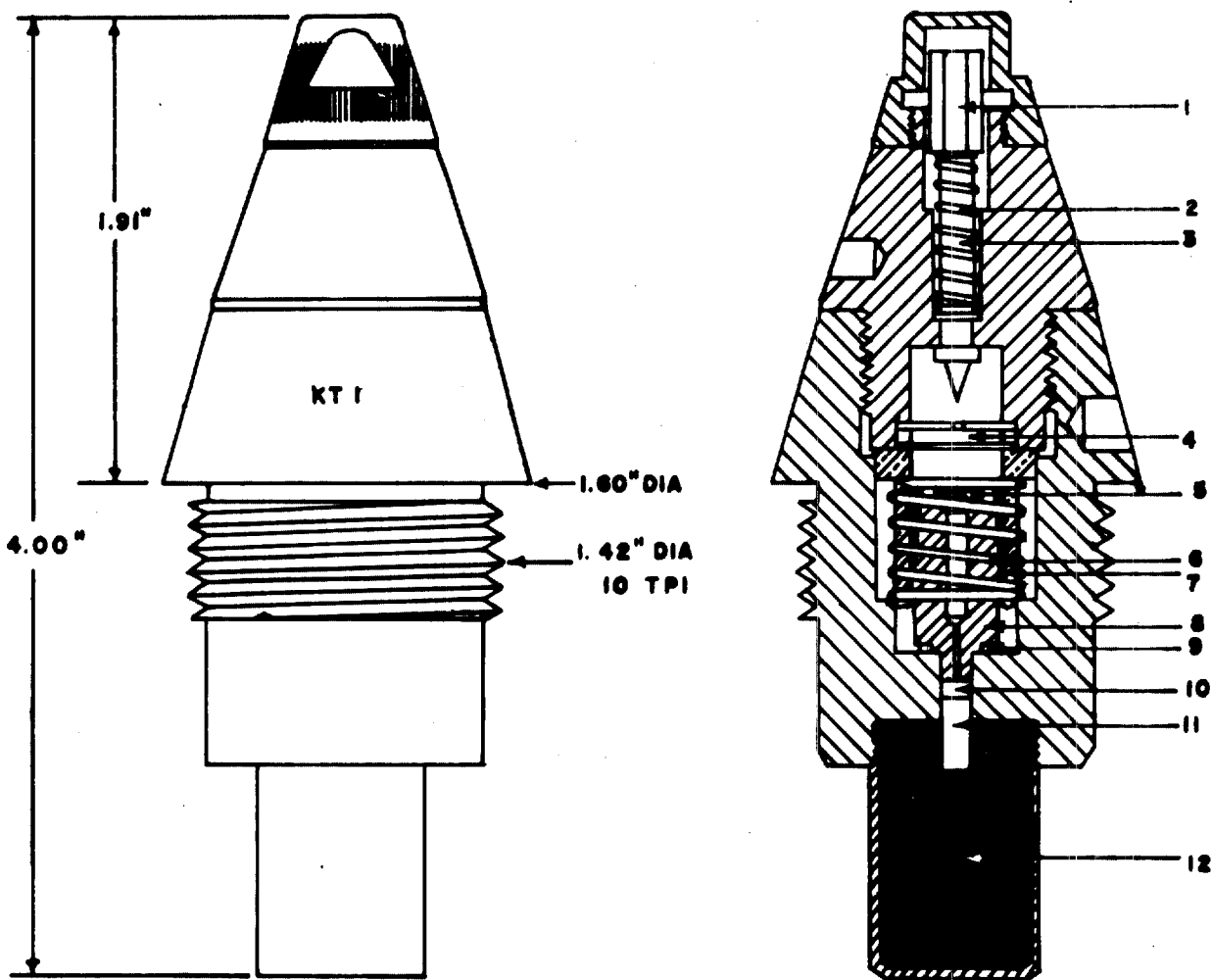

SOVIET POINT DETONATING IMPACT FUZE MODEL KT-2

a. General. This fuze is identical in construction and functioning to the KT-1 and KTM-1 fuzes. It differs from the latter only in having a smaller diameter of the base threads, being designed to screw into a booster cup (adapter) which screws into the well of the projectile. The KT-2 fuze is interchangeable with the KTM-2 fuze.

b. Weapons and projectiles with which used.

Weapons	Projectiles
76-mm: divisional guns M1902/30, M1933, M1936(F-22), M1939 (USV), and M1942 (ZIS-3); tank guns M1938/39 (L-11), M1939(F-32), M1940(F-34), and M1941 (ZIS-5).	76-mm Smoke ----- D-350
122-mm: howitzers M1938(M-30), M1909/37, and M1910/30	122-mm Smoke ----- D-462

SOVIET POINT DETONATING IMPACT FUZE MODEL KT-3

a. General. This fuze is identical in construction and functioning to the KT-1 and KTM-1 fuzes and is used with old 76-mm high-explosive projectiles having a well for the 3GT fuze. The KT-3 differs from the KT-1 and KTM-1 fuzes only in the smaller size of its base threads. The KT-3 fuze is interchangeable with the KTM-3 fuze.

b. Weapons and projectiles with which used.

Weapons	Projectiles
76-mm: divisional guns M1902/30, M1936(F-22), M1939(USV), and M1942(ZIS-3); tank guns M1927/32, M1938/39(L-11), M1939(F-32), M1940(F-34), and M1941(ZIS-5); regimental gun(howitzzer) M1927; mountain gun(howitzzer) M1909	76-mm HE ----- F-354

SOVIET POINT DETONATING IMPACT FUZE MODEL KTM-1

a. General. The KTM-1 is a point detonating, setback-armed fuze used with 45-mm, 57-mm, 76-mm, and 85-mm projectiles. The Soviets refer to this fuze as "semisecure" and boresafe. It is capable of nondelay and delay action depending on the fuze coloring and the use of the fuze cap. Use of the KTM-1 is reported to give greater fragmentation effect than use of the KT-1 fuze; use of the black-bodied KTM-1 fuze results in camouflets, duds, or sometimes a slight cratering effect if used for ranges over 2- $\frac{1}{2}$  miles and striking soft ground. The fuze action is regulated as indicated below:

<u>Fuze color and use of cap</u>	<u>Action</u>
Body and cap painted green, w/cap w/o cap	Short delay Instantaneous
Tinplated body with red nose, w/cap w/o cap	Long delay Short delay
Body and cap painted black, w/cap w/o cap	Short delay Instantaneous
Unplated body with red cap, w/cap w/o cap	Long delay Short delay

b. Characteristics.

Action ----- nondelay and delay  
 Loaded weight ----- 370 gm. (.814 lb.)  
 Body material ----- steel

c. Functioning. On firing, the arming sleeve (10) is set back, compresses the arming sleeve spring (9), overrides the stirrup (8), and locks itself to the primer holder assembly (11). The lower end of the primer holder assembly holds the aluminum sealing cushion (14) over the vent in the fuze body, shielding the detonator (12) from the primer (7), should accidental ignition occur. The striker (3) and the firing pin (5) are also set back, but the firing pin cannot reach the primer (7) at this time. After the projectile leaves the bore, the arming sleeve spring (9) raises the arming sleeve (10) and primer holder assembly (11) to a position directly under the safety disk (6). During the flight of the projectile, the firing pin spring (4) returns the striker (3) and the firing pin (5) to their original positions. On impact, when the fuze is set for instantaneous action (cap in place), the striker (3)

SOVIET POINT DETONATING IMPACT FUZE MODEL KTM-1

drives rearward and forces the firing pin (5) through a hole in the safety disk and into the primer. The primer is thus ignited and in turn sets off the detonator (12) and the booster (13). When the fuze is set for delay action (cap in place), the action is identical with that for nondelay action except that, on impact, the cap (2) prevents the striker (3) from being driven rearward. The primer holder assembly (11) moves forward and, overcoming the resistance of the safety disk (6), drives the primer (7) against the firing pin to initiate the explosive train of the fuze.

d. Weapons and projectiles with which used.

Weapons	Projectiles
45-mm: tank guns M1932, M1934, & M1938; antitank guns M1932 M1937, and M1942	45-mm Frag ----- O-240; O-240A O-240M
57-mm: antitank guns M1941, M1943 (ZIS-2), and M1949	57-mm Frag ----- O-271; O-271U
76-mm: divisional guns M1902/30, M1936 (F-22), M1939 (USV), & M1942 (ZIS-3); regimental gun (howitzer) M1927; mountain gun (howitzer) M1938; tank guns M1938/39 (L-11) & M1939 (F-32)	76-mm Frag ----- O-350; O-350A Frag HE -- OF-343; OF-350; OF-350A Frag-Gas ----- OKh-350 HE ----- F-354
85-mm: antiaircraft gun M1939; Tank guns M1943 (D-5T85) and M1944 (ZIS-S53); SP gun M1944 (D5-S85)	85-mm Frag ----- O-365K

SOVIET POINT DETONATING IMPACT FUZE MODEL KTM-1

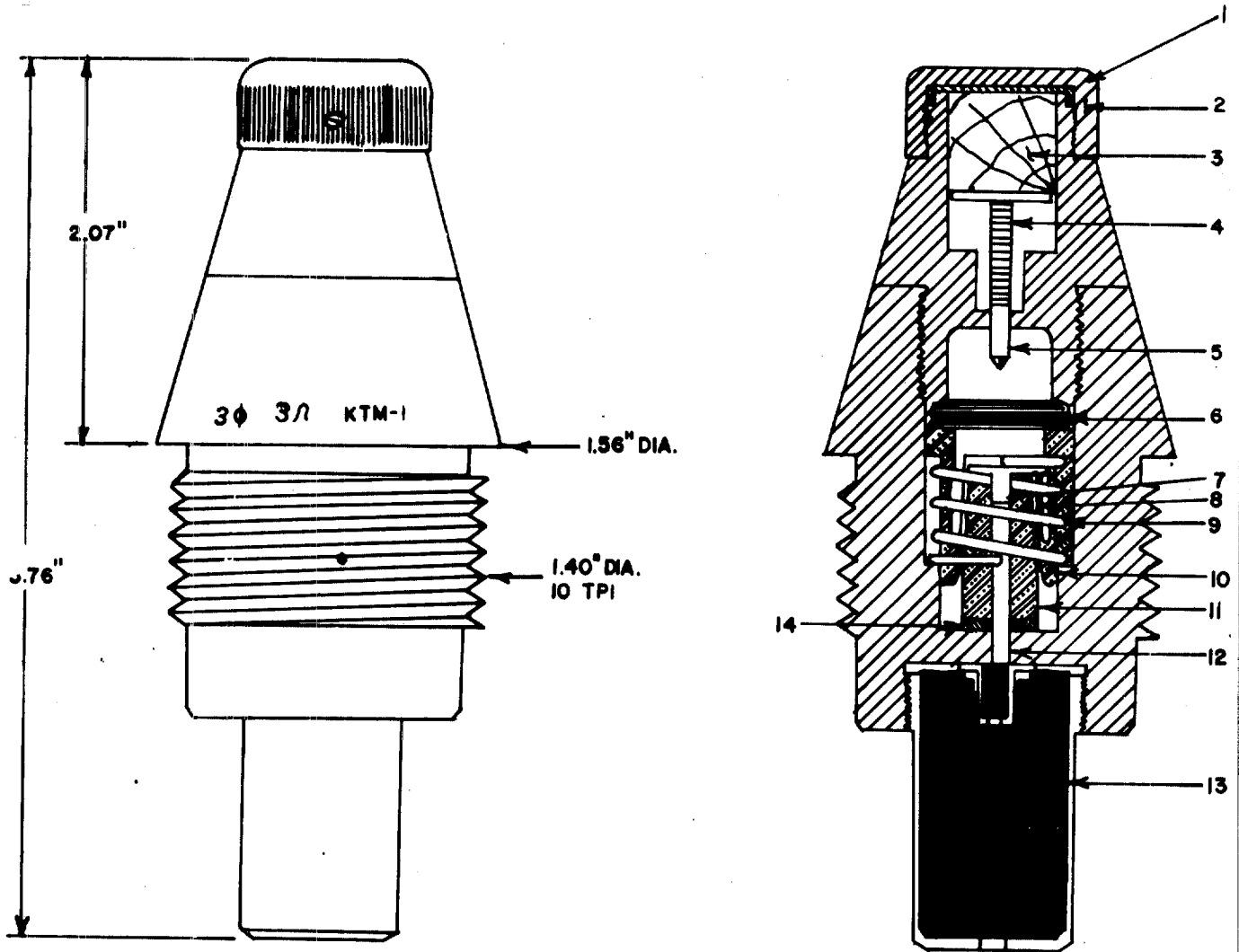

3-35/3-36

SOVIET POINT DETONATING IMPACT FUZE KTM-1-U

a. General. The Soviet KTM-1-U point detonating fuze is an improved, modified version of the earlier KTM-1 and is employed in the same applications. Like the KTM-1, the KTM-1-U is not detonator safe, but is bore safe. Arming is entirely by setback. The KTM-1-U displays a slight modification in the wooden firing pin plunger assembly and in the position and configuration of the detonator (10). Dimensions and configuration of KTM-1-U remain the same as the KTM-1.

b. Characteristics.

Action ----- Instantaneous and non-delay

Loaded weight ----- 370 grams (0.81 lbs.)

Body material ----- Steel

c. Functioning. Upon firing, setback causes the arming sleeve (4) to move rearward compressing the arming spring (6), permitting the stirrup prongs (7) to lock into the groove cut into the sleeve (4). This locks the arming sleeve (4) to the primer carrier (8). The fuze is not armed until this takes place. As acceleration diminishes, the arming spring (6) moves the married arming sleeve (4) and primer carrier (8) forward until the nose of the carrier is stopped by the safety ring (3). For instantaneous action, the nose cap (1) is removed so that upon impact, the direct acting firing pin (2) is driven into the primer (5). Flame from the primer passes through the flash hole (9) in the bottom of the fuze body and functions the detonator (10) and the booster (11). For non-delay action the nose cap (1) is left in place. The direct acting firing pin is not moved upon impact; instead, inertia causes the married arming sleeve (6) and primer carrier (8) to move forward shearing the four lugs on the safety ring (3). The primer impales itself on the stationary firing pin initiating the explosive train functioning. The slight delay produced by inertia functioning is sufficient to permit projectile penetration before detonation.

d. Weapons and projectiles with which used.

Weapons

Projectiles

Same as Soviet KTM-1

SOVIET POINT DETONATING IMPACT FUZE KTM-1-U

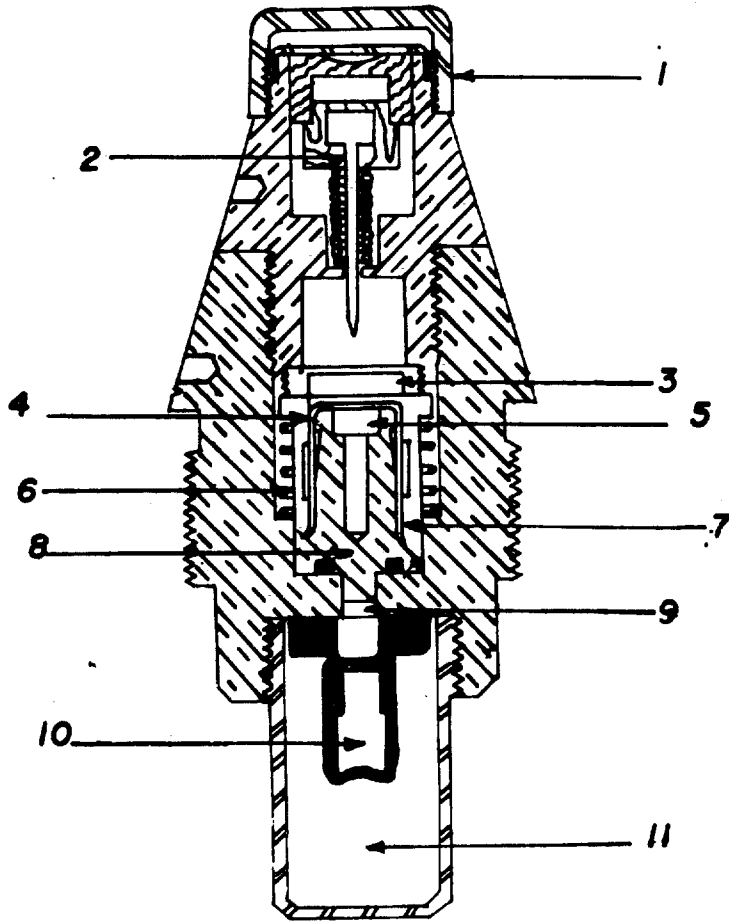

SOVIET POINT DETONATING IMPACT FUZE MODEL KTM-2

a. General. This fuze is identical in construction and design to the KTM-1 fuze and is used with 76-mm divisional guns and 122-mm howitzer smoke projectiles. The KTM-2 and KT-2 fuzes are interchangeable. They differ from the KTM-1 and KT-1 fuzes in the thread size, the thread diameter being somewhat smaller in the KTM-2 and KT-2.

b. Weapons and projectiles with which used.

Weapons	Projectiles
76-mm: divisional guns M1902/30, M1933 M1936 (F-22), M1939 (USV), and M1942 (ZIS-3)	76-mm Smoke ----- D-350
122-mm: howitzer M1938 (M-30)	122-mm Smoke ----- D-462

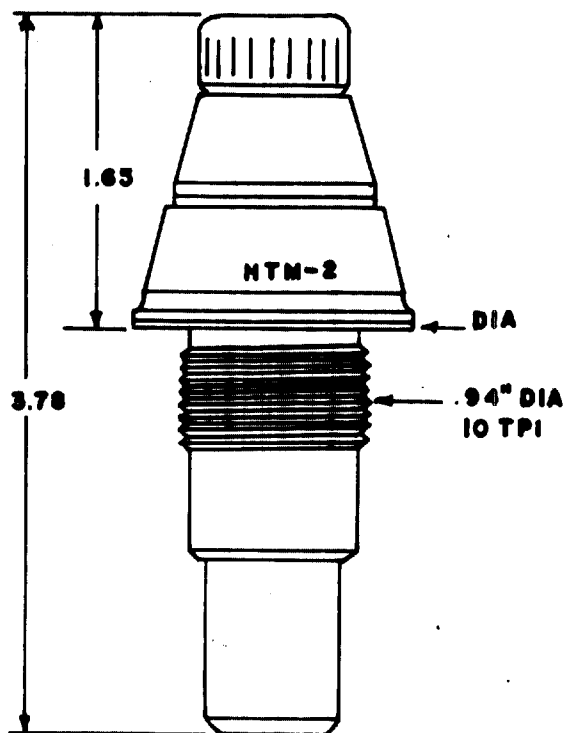

SOVIET POINT DETONATING IMPACT FUZE MODEL KTM-3

a. General. This fuze is identical in construction and functioning to the KTM-1 fuze and is interchangeable with the KT-3 fuze. The KTM-3 fuze differs from the KTM-1 in thread size, the former having a somewhat smaller thread size. The KTM-3 and KT-3 fuzes are used with old 76-mm high-explosive projectiles having a well for the 3GT fuze.

b. Weapons and projectiles with which used.

Weapons	Projectiles
76-mm: regimental gun (howitzer) M1927; tank gun M1927/32; mountain gun (howitzer) M1909	76-mm HE ----- F-354 Frag-HE ----- OF-350

SOVIET POINT DETONATING IMPACT FUZE MODEL KTMZ-1

This fuze is almost identical in construction and functioning to the KTM-1 fuze, although it differs from the KTM-1 by having a delay pellet pressed into the powder plug. It possesses the same delay action, whether capped or uncapped. The KTMZ-1 may be identified by the color of its head plug and setting cap, which are painted either black or red.

SOVIET POINT DETONATING IMPACT FUZE MODEL KTMZ-2

This fuze is identical in construction and functioning to the KTM-2 and KT-2 fuzes, except for the fact that it has a delay pellet pressed into the powder plug. It possesses the same delay action whether it is capped or uncapped.

SOVIET POINT DETONATING IMPACT FUZE MODEL KTZ-2

The KTZ-2 differs from the KT-2 fuze by having a delay pellet, which is pressed into the powder plug. The two fuzes are otherwise identical in construction and functioning.

3-42 | 3-42

SOVIET POINT DETONATING IMPACT FUZE M-1

a. General. The M-1 is a point detonating, nondelay fuze of conventional design. It is known to be used with 50-mm, 82-mm, and 120-mm Soviet mortars, and possibly may be used with 107-mm and 160-mm mortars. This fuze is considered obsolete; however, it is possible that the fuze is still being used. The Soviets refer to the fuze as "unsecured!" During storage and transport the fuze is protected by a metal cap (1) which may be removed prior to firing. If a red stripe is visible on the side of the projecting striker head, the fuze is armed and must not be fired.

b. Characteristics.

Action ----- nondelay  
Loaded weight ----- 250 gm. (.55 lbs)  
Body material ----- ?

c. Functioning. Upon discharge, the arming sleeve (10) sets back and its beveled edge cams the safety pin (11) outward and the upper check ball (3) drops into the recessed portion of a well on top of the arming sleeve (10), thus freeing the sleeve for forward movement. When the projectile leaves the bore, the arming sleeve spring (4) decompresses and forces the sleeve forward, permitting the lower check balls (5) to drop inside a well in the sleeve. This frees the striker (6) for rearward movement. During the flight of the projectile, tension of the safety spring (7) prevents the striker and firing pin (12) from moving rearward, detonating the projectile. Upon impact, the striker (2) is driven rearward, and the firing pin (12) sets off the detonator (8) which in turn actuates the booster (9) and the explosive charge of the Projectile.

d. Weapons and projectiles with which used

Weapons	Projectiles
50-mm: company mortars M1938, M1940 and M1941	50-mm Frag ----- 0-822; 0-822A; 0-822Sh
82-mm: battalion mortars M1937 (82-BM-37), M1941 (82-BM-41), and M1943 (82-BM43)	82-mm Frag ----- 0-832; 0-832D Smoke ----- D-832
120-mm: regimental mortars M1938 and M1943	120-mm Frag-HE ----- OF-843 Incendiary----- Z-843A

SOVIET POINT DETONATING IMPACT FUZE M-1

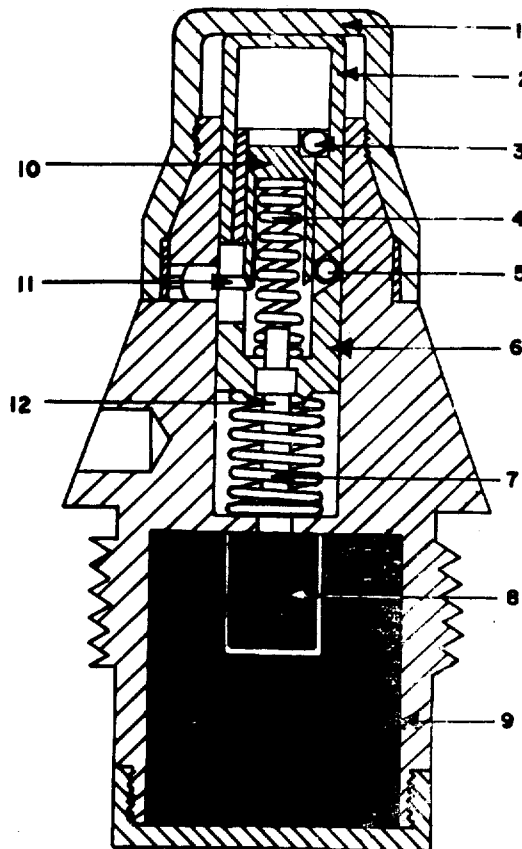
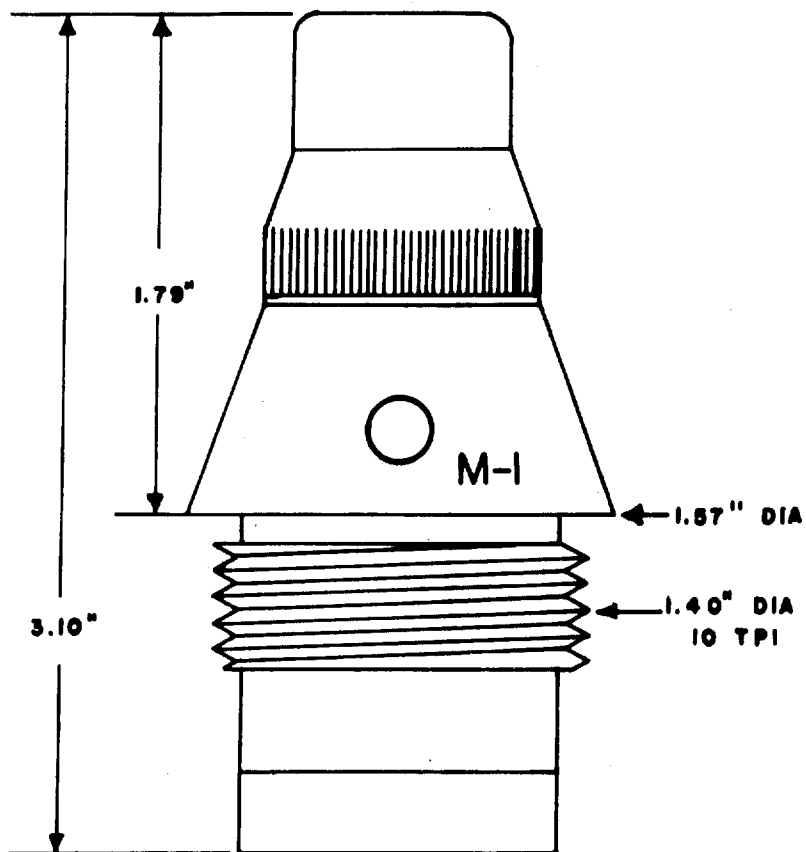

SOVIET POINT DETONATING IMPACT FUZE MODEL M-2

a. General. The M-2 is a point detonating, nondelay action fuze consisting of a plastic body on a wire armature, a direct-action-type percussion mechanism, and a detonator. Although the Soviets refer to this fuze as "unsecured", it is sufficiently safe in spite of its simplicity of structure. Until discharge, the firing pin (2) is separated from the detonator pellet by the safety block (5), which is a steel disc. The safety block is held in position by the safety sleeve (4). One end of the setback spring (3) holds the safety block while the other end of the spring supports the stirrup (1).

b. Characteristics.

Action ----- Instantaneous  
Loaded weight ----- ? grams ( ? lbs)  
Body material ----- Plastic

c. Functioning. On firing, the stirrup (1) sets back, overcomes the resistance of the setback spring (3), and engages the lip of the safety sleeve. When the shell leaves the mortar tube, creep force carries the stirrup forward and the safety block (5) is then free to move away from under the firing pin, thereby providing an uninterrupted path to the detonator assembly (6). Upon impact, the firing pin is driven into and actuates the detonator (6), which in turn actuates the booster (7).

d. Weapons and projectiles with which used.

Weapons	Projectiles
82-mm: battalion mortars M1937 (82-BM37), M1941 (82-BM41), and M1943 (82-BM43)	82-mm Frag ----- O-832; O-832D Smoke ----- D-832

SOVIET POINT DETONATING IMPACT FUZE MODEL M-2

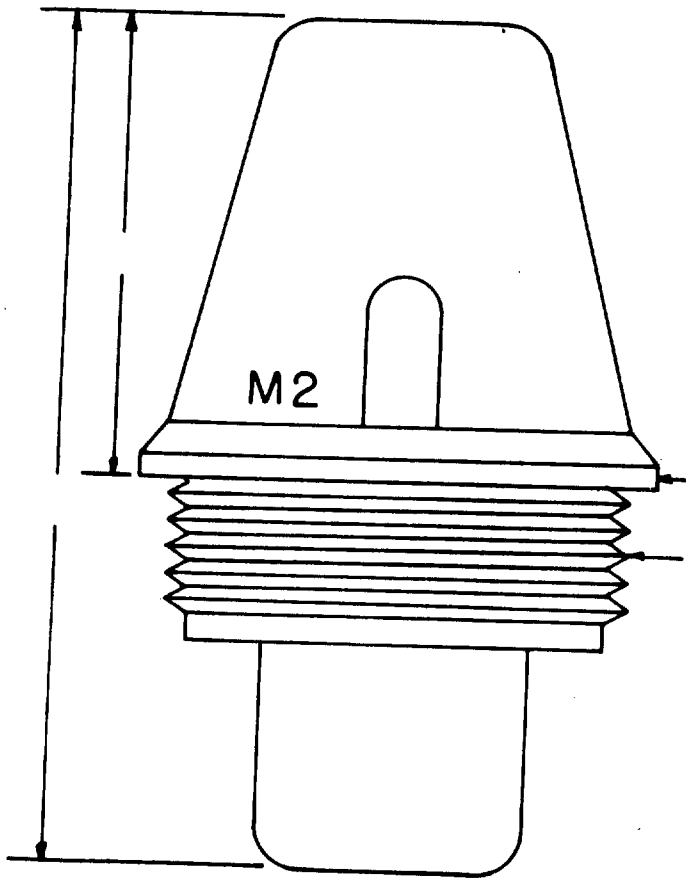

DIA  
DIA  
TPI

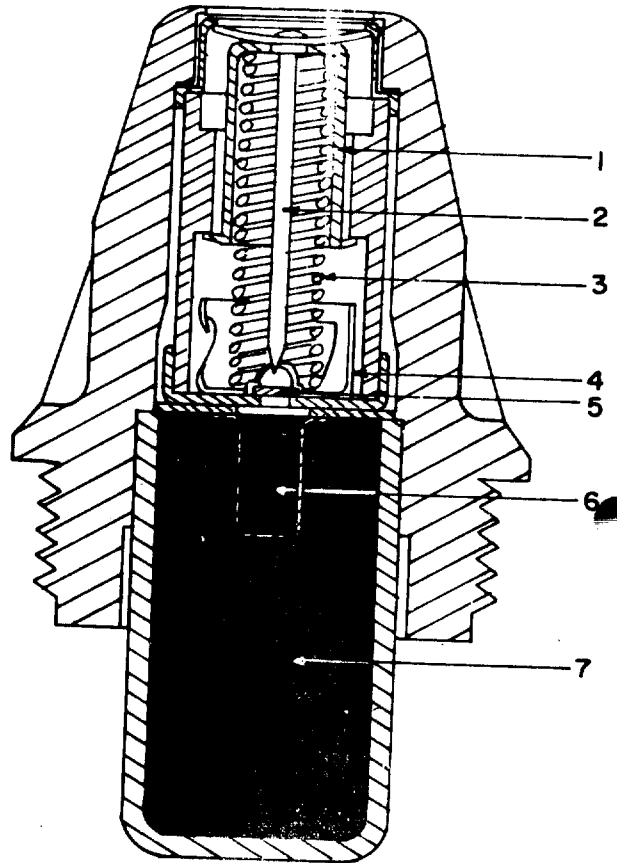

SOVIET POINT DETONATING IMPACT FUZE MODEL M-3

The M-3 is a point detonating, nondelay fuze which is similar in design and functioning to the M-2 fuze, and is used with the same projectiles as the M-2 fuze. The body of the M-3 fuze is constructed of steel, rather than the plastic material used in the M-2; in all other respects the two models appear to be identical.

3-47/3-48

SOVIET POINT DETONATING IMPACT FUZE MODEL M-4

a. General. The M-4 is the fourth model of the "M" series of Soviet mortar fuzes. It is usually used for explosive mortar shells, but can be used with smoke and incendiary shells. It is known to be used with 82mm Mortars and can be used with 107mm and 120mm Mortars. There is no visible means to determine whether the fuze is armed or unarmed.

b. Characteristics

Action----- nondelay  
Loaded weight----- 300gm. (.66 lb.)  
Body material----- steel or plastic

c. Functioning. On firing, the stirrup (4) set back, forces its flanged lower end down into the hollowed-out safety block retainer (9), and compresses the spring (3). This action retains the safety block (5) between the firing pin (8) and the detonator (6) until the projectile has left the mortar tube. After the projectile has left the tube, the spring (3) decompresses and forces the stirrup (4) upward. During this upward movement of the stirrup, its flanged lower end carries the safety block retainer (9) with it. As the safety block retainer moves upward, the cammed surface on its outer circumference engages a vertical tongue, extending upward from the safety block (5) and cams the block outward, away from its position over the detonator (6), thus allowing the firing pin (8) free access to the detonator. On impact, the foil membrane (1) is ruptured and the firing pin is driven rearward, forcing its pointed lower end into the detonator, successively actuating the detonator and the booster (7) which, in turn, detonate the shell.

d. Weapons and projectiles with which used.

Weapons	Projectiles
82mm: battalion mortars M1937 M1941 etc	82mm Frag ----- 0-832; 0-832D Smoke----- D-832
	120mm Frag-HE----- OF-843; OF843A Incendiary -----Z-843A Smoke-----D-843A

SOVIET POINT DETONATING IMPACT FUZE MODEL M-4

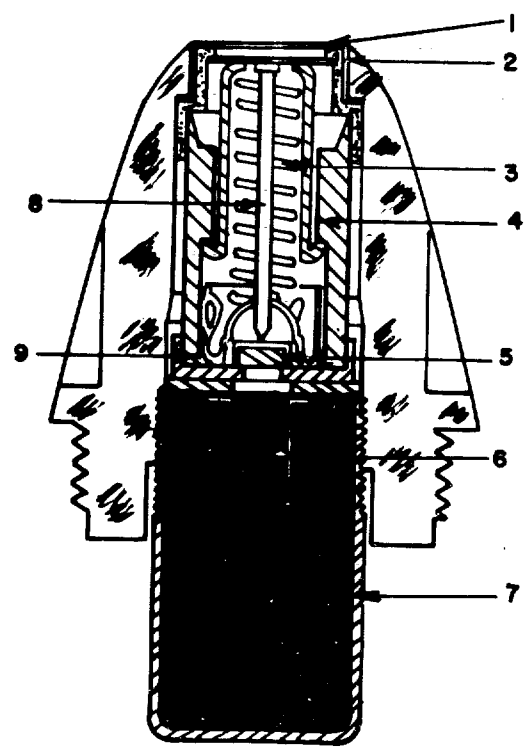
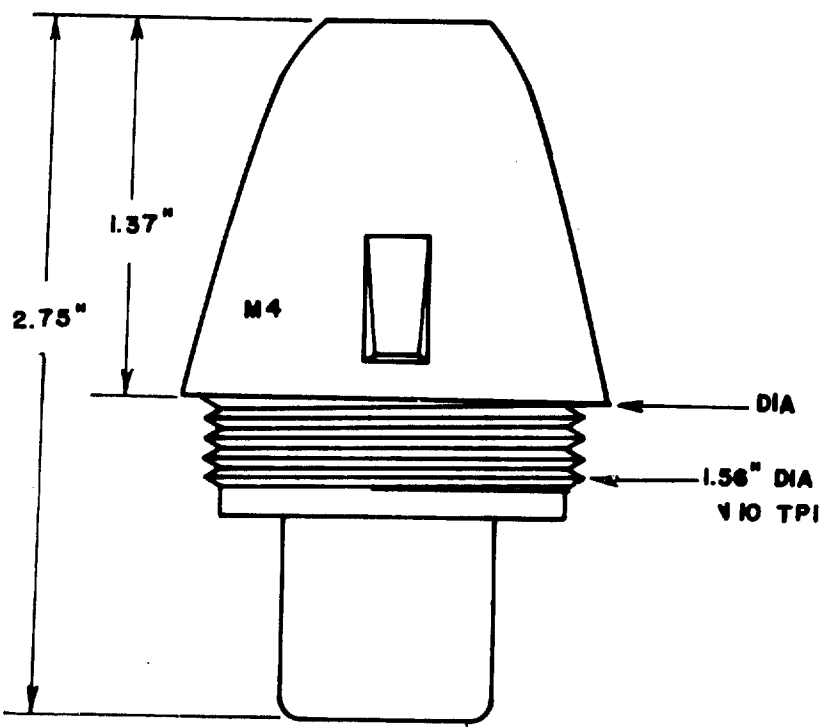

SOVIET POINT DETONATING IMPACT FUZE M-5

a. General. The M-5 is a point detonating, setback-armed, nondelay action fuze. It is used in projectiles fired from 82-mm mortars. The fuze is considered boresafe; however, the Soviets refer to it as "unsecured". The M-5 fuze functions nearly the same as the M-2 and M-3 fuzes and is considered almost identical to the M-4 in construction and functioning.

b. Characteristics.

Action ----- nondelay  
Loaded weight -----77.11 gm. (.17 lb)  
Body material ----- plastic

c. Functioning. The firing pin (5) is separated from the detonator assembly (7) by a small safety disk (9). This disk is held in place by a safety cup (6). The safety spring (4) holds the cup and disk in place. When the mortar is fired, setback causes the stirrup (3) to move rearward and engage the prongs of the safety cup (6). As the shell decelerates during flight, creep force allows the safety unit to move forward and the safety disk to fall away from under the firing pin, thereby providing the pin with free access to the detonator assembly (7). On impact, the foil disk (1) is ruptured and the firing pin strikes the detonator assembly, actuating it and the booster (8) in turn.

d. Weapons and projectiles with which used

Weapons	Projectiles
82-mm: battalion mortars M1937 (82-BM37), M1941 (82-BM-41), and M1943 (82-BM43)	82-mm Frag ----- O-832; O-832D Smoke ----- D-832

SOVIET POINT DETONATING IMPACT FUZE M-5

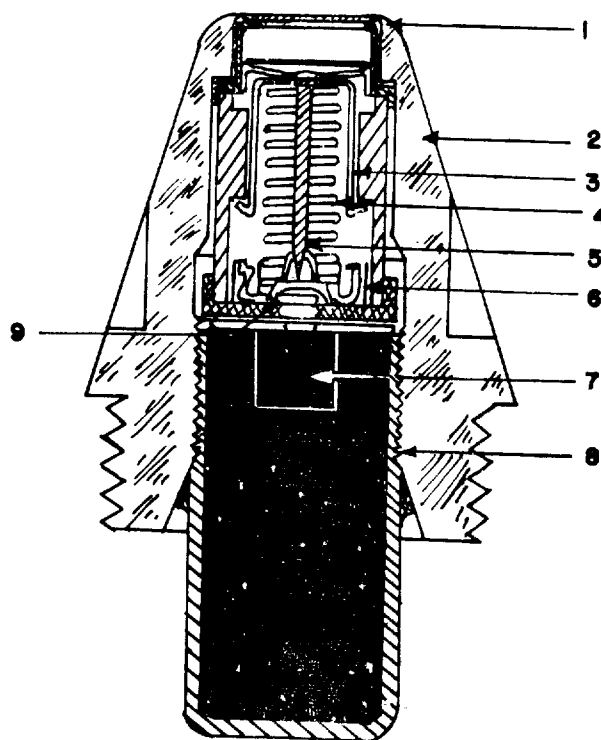
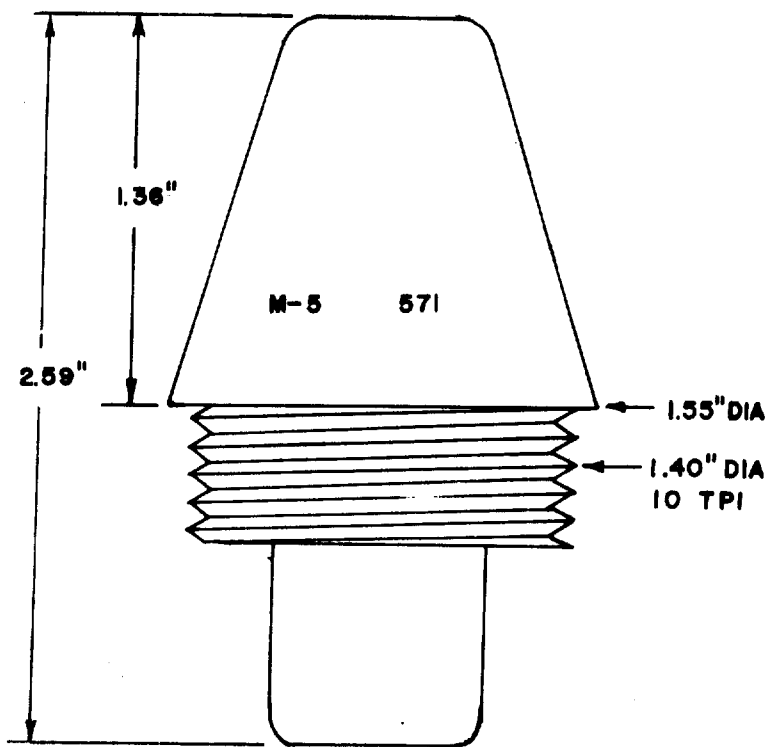

## SOVIET POINT DETONATING IMPACT FUZE MODEL M-6

a. General. The M6 fuze has become the standard 82-mm Mortar fuze almost to the total exclusion of all other fuzes. The M6 is a superquick fuze used with low velocity projectiles. It is bore and detonator safe possessing a lateral moving detonator slider. The fuze consists of a brown plastic body made from compression molded, thermosetting, urea formaldehyde with a cotton filler, arming assembly, slider, detonator, lead charge and booster.

A steel sleeve with a Zig-Zag slot, a spring, three steel balls and a slider comprise the arming assembly. The slider, with its out-of-line detonator, is maintained in the safe condition by the firing pin, which extends into a hole in the slider, preventing its movement. A coil spring is compressed between the slider and inner fuze wall and provides power to move the slider at arming.

The protective steel cap (1) which is secured by a pull wire is removed prior to firing. This exposes the thin crush cap (12) which is entirely water proof. The firing pin (8) prevents the slider (9) from moving and thus holds the detonator out-of-line. The firing pin (8) is locked in position by two steel balls (7) which are housed in the arming sleeve (2). The coiled arming spring (6) is held compressed under the arming sleeve (2), while the arming sleeve is held by the sleeve retaining ball (3) wedged between the firing pin head and arming sleeve.

### b. Characteristics.

Action ----- Instantaneous

Loaded weight ----- 127.1 grams (0.28 lbs.)

Body material ----- Plastic

c. Functioning. Upon firing, setback forces the arming sleeve (2) downward. This releases the arming sleeve retaining ball (3) which falls into the fuze body cavity (4). The arming sleeve (2) continues rearward, delayed by the Zig-Zag slot in the arming sleeve and guided by a pin on the slider holder (5) until it reaches the end of its travel. As setback ceases, the arming spring (6) expands moving the arming sleeve (2) forward, releasing the two firing pin retaining balls (7), which fall into the body cavity. This permits the firing pin (8) to rise, powered by the arming spring (6), moving the point of the firing pin (8) out of its hole in the slider (9). The slider (9), powered by the slider spring (10), moves laterally aligning the detonator (11) with the firing pin (8). The fuze is now armed. Upon impact, the firing pin (8) is driven downward by a combination of compressed air and debris crushing the copper membrane. The point of the firing pin pierces the detonator (11) initiating the lead charge (13) and the booster (14).

SOVIET POINT DETONATING IMPACT FUZE MODEL M-6

d. Weapons and projectiles with which used.

Weapons

82-mm: Mortar M1937, M1942, & M1943

Projectiles

82-mm HE-Frag --- O-832; O-532D

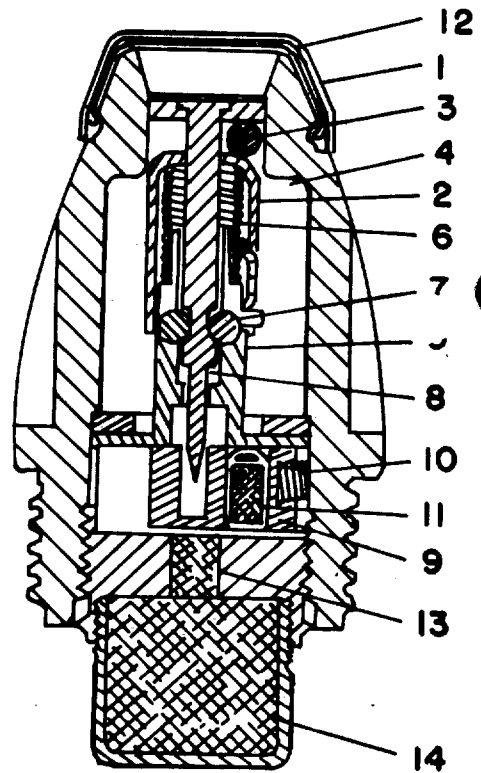
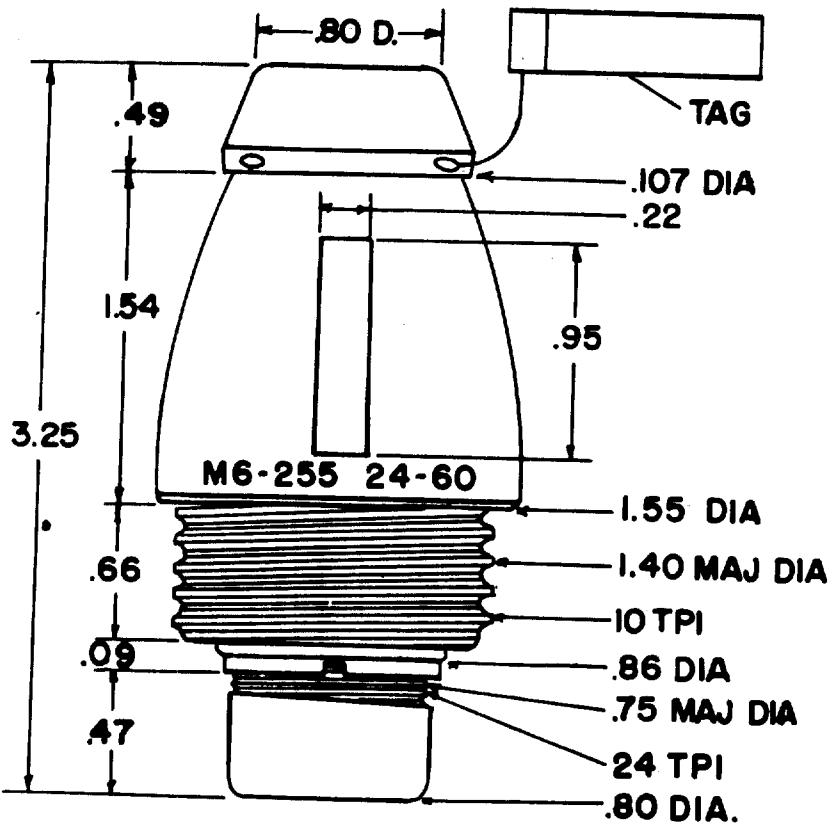

## SOVIET POINT DETONATING IMPACT FUZE MODEL M12

a. General. The M12 fuze is a setback armed, point detonating fuze with optional superquick and fractional second delay functioning upon impact. The fuze consists of three assemblies; the striker assembly, the delay assembly, and the booster assembly.

The striker assembly is identical with that used in the M6 fuze, except the M12 possesses a primer instead of a detonator, and is interchangeable. Basically the fuze is an M6 with selective superquick or delay action. The assemblies are mounted in a rugged steel body which is completely waterproof. There are two delay elements mounted in parallel. Both provide the same delay period. Superquick action is selected by rotating the interrupter within its packing gland, until the indicator arrow points to "0". In the delay setting the arrow points to the "3" position.

### b. Characteristics.

Action ----- Superquick or delay  
Loaded weight ----- 536.3 grams (1.18 lbs.)  
Body material ----- steel

c. Functioning. The arming functioning is identical with that of the M6 fuze. Upon impact, the firing pin initiates the primer which produces a flash. On the superquick option the flash passes through the axial hole in the body of the delay housing (13) igniting the flash detonator (15) and detonating the booster. Simultaneously both delay elements are ignited but serve no purpose since the fuze detonates prior to their functioning the attached flash pellets. If the interrupter (14) is set for delay action, the primer flash is blocked in the axial hole and the black powder in the upper chamber of both delays (12) is ignited. After the delays burn through, the flash charge in the bottom of each delay is ignited, which then flashes into the detonator (15) producing fuze detonation.

### d. Weapons and projectiles with which used.

Weapons	Projectiles
120-mm Mortars M1938 and M1943	120-mm Frag ----- F-843, OF-843, OF-843A



SOVIET POINT DETONATING IMPACT FUZE MODEL M-50

a. General. The M-50 is a point detonating, setback-armed, nondelay action fuze used only with fragmentation projectiles. The M-50 is an extremely sensitive fuze which the Soviets consider "unsecured". Prior to use, the nose of the fuze is covered with a lead foil cap. This cap must be removed before firing. The firing pin (3) is immobilized by two check balls (6) which are lodged between the bottom of the striker head (1) and the top of the stirrup (2), and two check balls (8) lodged at the lower end of the firing pin (3). This prevents any movement of the firing pin until firing takes place. It is not recommended that the fuze be removed from duds; however, if removal must be accomplished, loosen the grub screw that secures the fuze to the projectile and unscrew the fuze from the projectile. If the striker head is protruding, and a red line can be seen across its diameter, it is recommended that the fuze be blasted in place.

b. Characteristics.

Action ----- nondelay

Loaded weight ----- 112 gm. (.25 lbs)

Body material ----- steel

c. Functioning. On firing, the stirrup (2) sets back and allows the upper check balls (6) to fall away, thus releasing the firing pin (3) for forward movement. After the projectile leaves the mortar tube, the anti-creep spring (7) forces the stirrup forward, allowing the lower check balls (8) to fall away, freeing the firing pin for rearward movement. At this point, the striker head (1) protrudes approximately one-half its length above the top of the body of the fuze, showing a red line across its diameter. On impact, the firing pin is driven rearward, initiating the detonator (4) and booster (5), functioning the fuze.

d. Weapons and projectiles with which used

Weapons

Projectiles

50-mm: company mortars M1938,  
M1940, and M1941

50-mm Frag ----- O-822;  
O-822A; O-822Sh

SOVIET POINT DETONATING IMPACT FUZE MODEL M-50

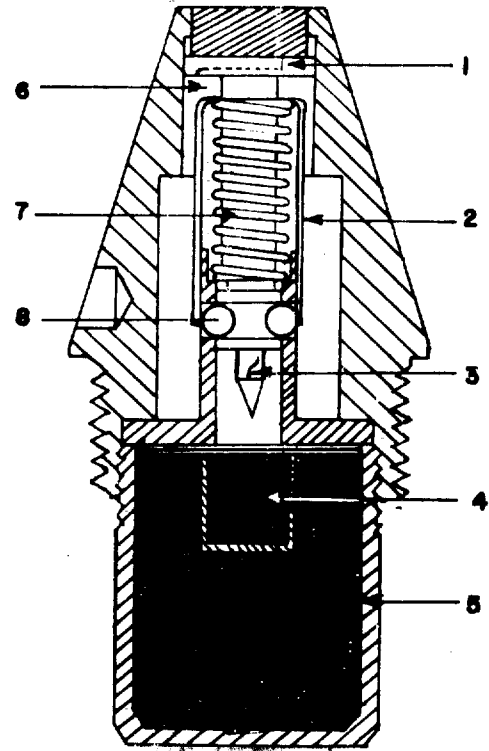
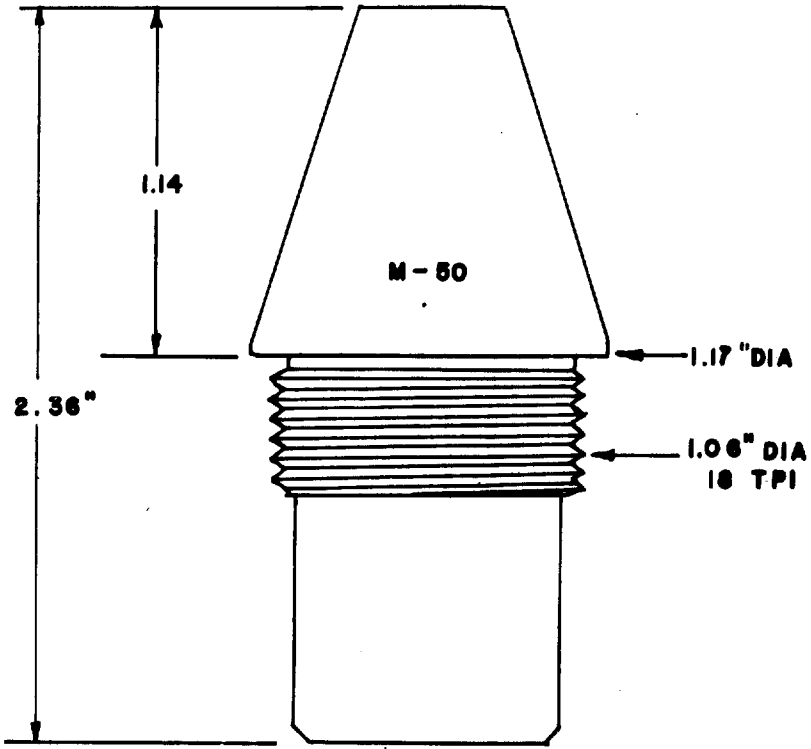

## SOVIET POINT DETONATING IMPACT FUZE MG-N

a. General. The MG-N is a bore safe, out-of-line detonator fuze. It employs a setback initiated, pyrotechnic, arming delay feature seen in the MG-57 fuze. The MG-N is a representative of the current Soviet effort to produce bore safe, detonator safe fuzes to replace the earlier "unsecured" and "semisecure" fuzes. It is expected that the MG-N will replace the KTM series fuzes in all applications. The MG-N has a single piece steel body that has been waterproofed at its two openings by sealing compound. The shipping cap protects the firing pin membrane (2). When the cap is removed the fuze functions instantaneously; when the cap is left on, a slight functioning delay is obtained. The firing pin (3) is a hollow aluminum, two piece assembly. It assists in locking the rotor (4) in the safe position during set-back. The rotor rotates on pins in the rotor housing. It is held out-of-line by two centrifugal detents. One is of the direct arming type (18) and the other is of the delay arming type (19) employing a consumable black powder pellet to block the detent. Rotor arming is delayed until the pellet is consumed and the detent is moved into the evacuated cavity. The rotor delay arming detent (19) is initiated by the set-back primer assembly that consists of a weighted moveable primer (13), setback spring (15), and a fixed firing pin (16). This assembly is parallel to the fuze axis. This assembly is employed only to ignite the delay arming pellet (20). The fuze body detonator (7) rests in the center of the lower part of the rotor housing (5) and is initiated by the rotor detonator (6). The booster (11) is separated from the rotor housing (5) by a paper disc and a plastic disc (8). These body discs are employed as space fillers to render the internal components rigid. The booster cup (11) contains the booster explosive (12) which is pressed to form a rounded, convex head. The purpose of this configuration has not been determined.

### b. Characteristics.

Action ----- Instantaneous  
Loaded weight ----- 347 grams (0.76 lbs.)  
Body material ----- Steel

c. Functioning. When fired, the setback causes the weighted delay arming primer (14) and weight (13) in the rotor housing (5) to move rearward against its spring (15) and impale itself upon the firing pin (16). The resulting flame flashes through a groove (21) in the side of the rotor housing initiating the black powder delay arming pellet (20) holding the rotor locking detent (19) in position. The rotor (4) remains locked. As the powder (20) burns, the rotor locking detent moves into the evacuated area by centrifugal force and cam action of the rotor (4). Simultaneously, the opposite rotor locking detent (18) moves outward against its spring by centrifugal force. This unlocks the rotor (4). The rotor is now turned

SOVIET POINT DETONATING IMPACT FUZE MG-N

by centrifugal force until the detonator (6) is aligned under the firing pin (3). Upon impact, the firing pin is driven into the stab sensitive rotor detonator (6), which initiates the body detonator (7) and booster.

d. Weapons and projectiles with which used.

Weapons	Projectiles
76-mm: Gun M1942(ZIS-3)	76-mm HE-Frag O-350A
76-mm: Tank Gun D-56T	76-mm HE-Frag OF-350 & OF-350A

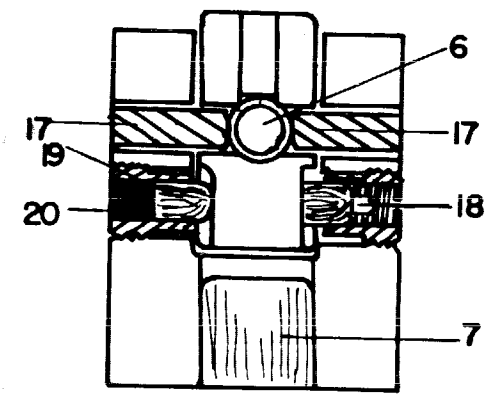
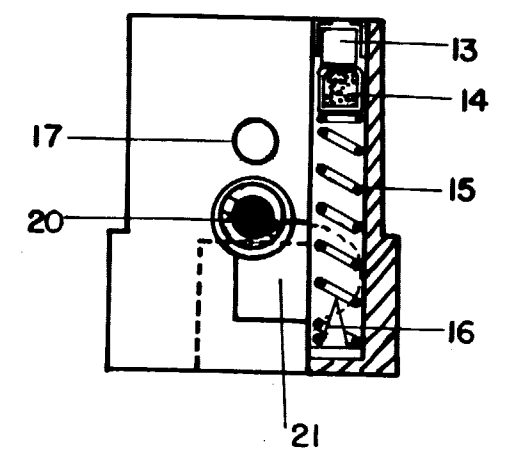
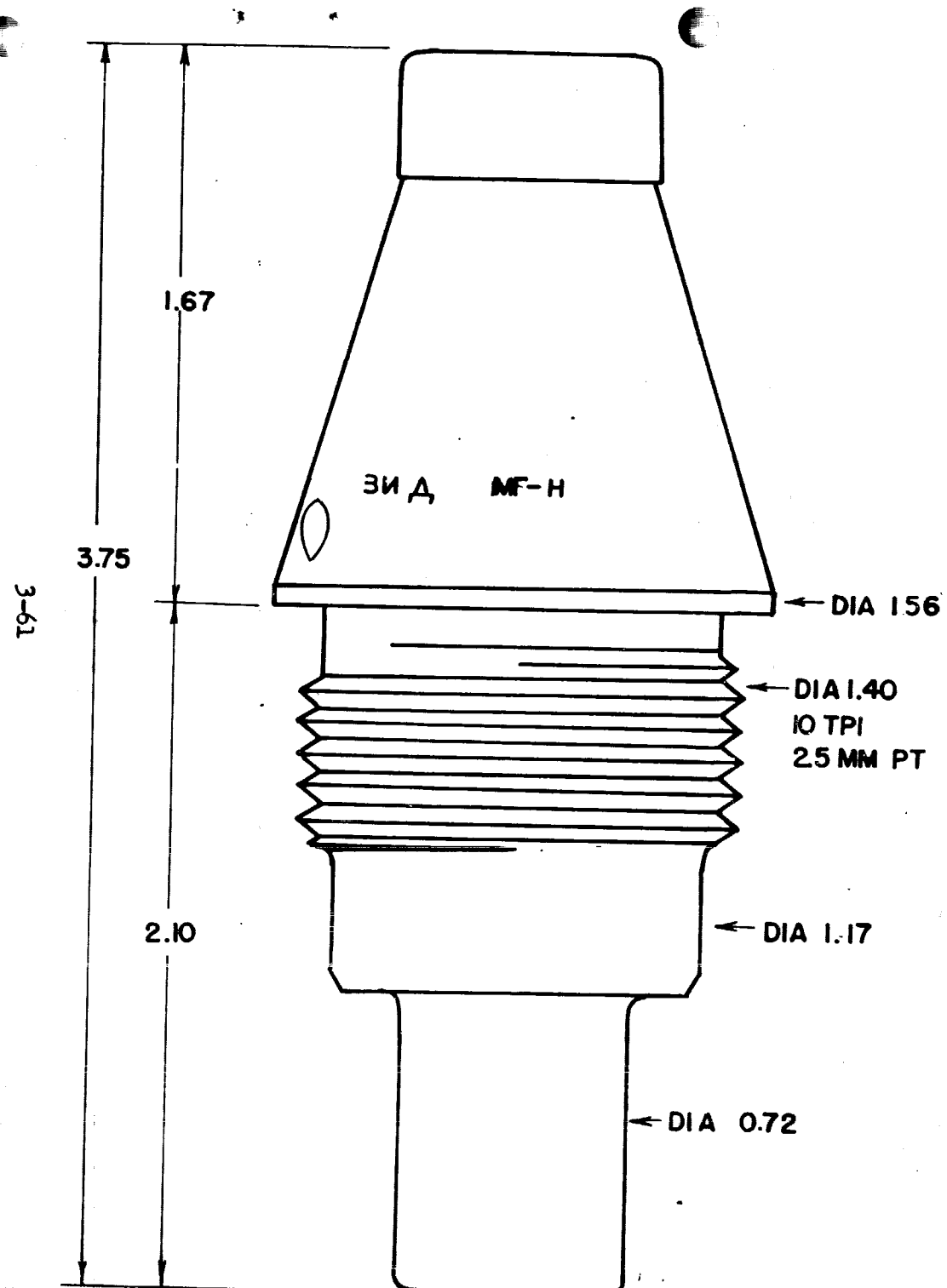

SOVIET POINT DETONATING IMPACT FUZE NG-K

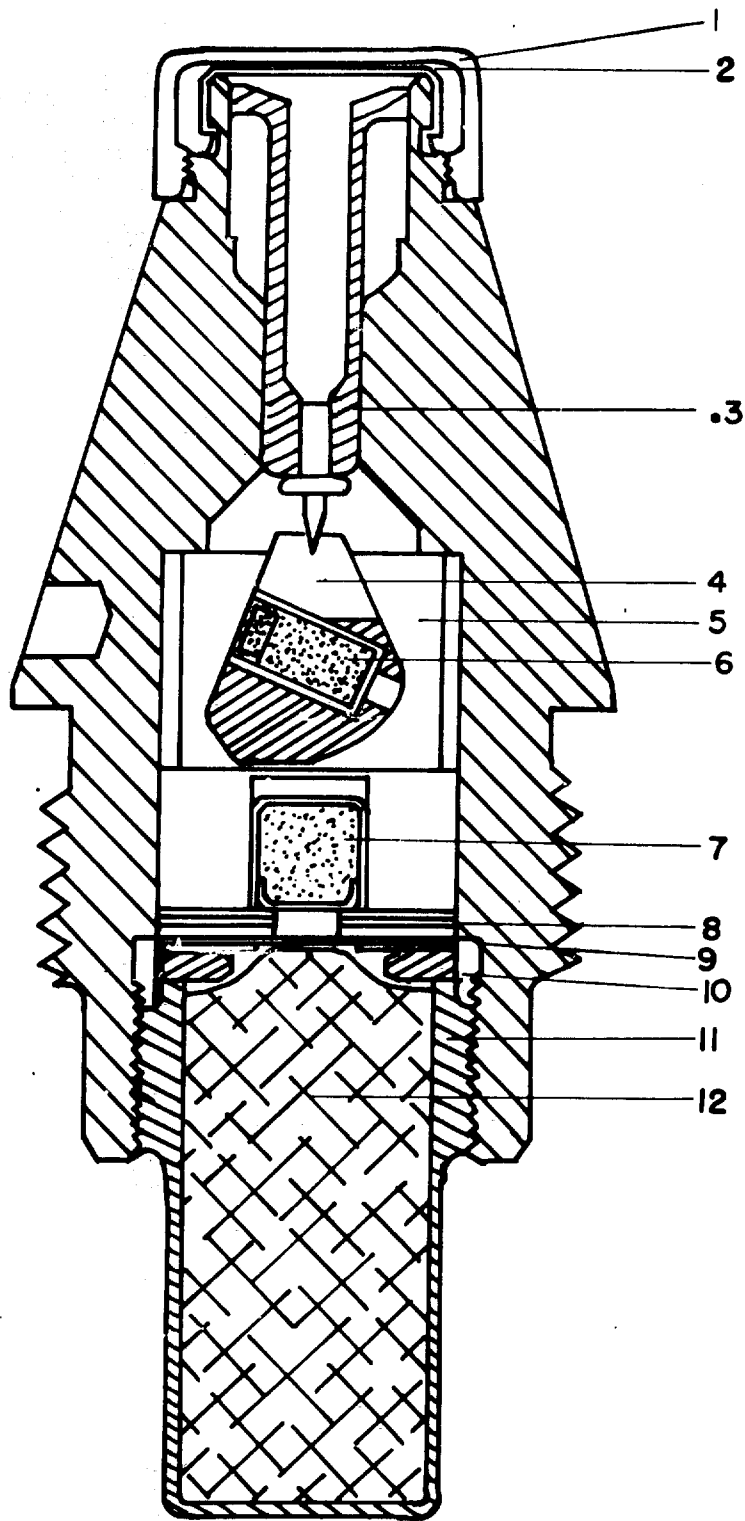

SOVIET POINT DETONATING IMPACT FUZE MODEL MP

a. General. The MP (Minnyy Plastmassovyy: literally, "Mortar, Plastic") fuze was originally developed for use with 50-mm HE mortar projectiles, but can be used with 82-mm projectiles. The body of this fuze is made of plastic, which accounts for its light weight. The entire fuze, including the metal cap, is black. It is boresafe through a setback-actuated mechanical block safety. The Soviet safety classification of the "MP" fuze is "unsecured". It is believed that the fuze is no longer used with 82-mm projectiles, having been replaced with the MP-82 mortar fuze. This fuze has been found inerted and used as a closing plug in 122-mm HE and HEAT projectiles.

b. Characteristics.

Action ----- nondelay  
Loaded weight ----- 80 gm. (.176 lb.)  
Body material ----- plastic

c. Functioning. Prior to firing, the small metal boresafety cylinder (6) located in the base of the bushing (4) is held in position by the arming spring (10) so as to prevent the firing pin (3) from contacting the primer pellet (7). Upon firing, the arming weight (5) is violently set back against the arming spring (10), freeing one end of the arming spring from its recess in the bushing (4). The tension of the arming spring then causes the arming spring to move in an oblique direction carrying with it the boresafety cylinder (6), thereby clearing the path of the firing pin. Upon impact, the nose cap (1) is crushed rearward, driving the firing pin (3) into the primer pellet (7) in the bushing cup (11) and setting off the detonator (8), which in turn explodes the booster (9). The booster then detonates the explosive filler of the projectile.

d. Weapons and Projectiles with which used.

Weapons	Projectiles
50-mm: company mortars M1938, M1939, M1940, and 1941	Frag ----- 0-822 0-822A
82-mm: battalion mortars M1937 (82-BM37), M1941 (82-BM41), and M1943 (82-BM43)	Frag ----- 0-832

SOVIET POINT DETONATING IMPACT FUZE MODEL MP

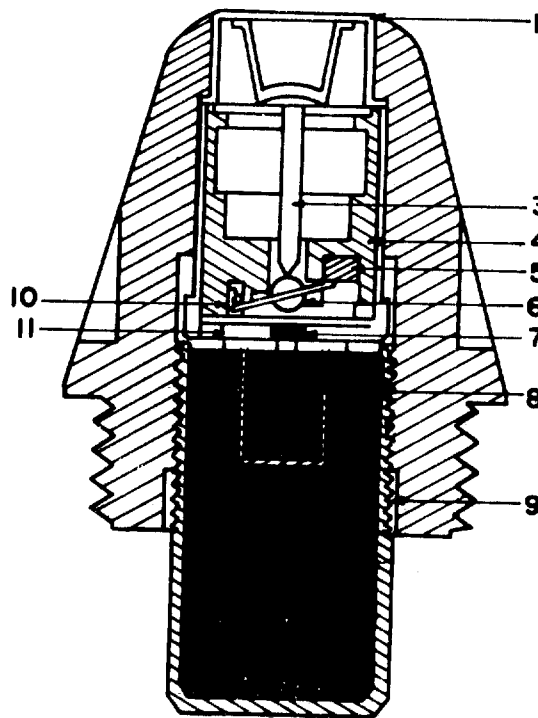
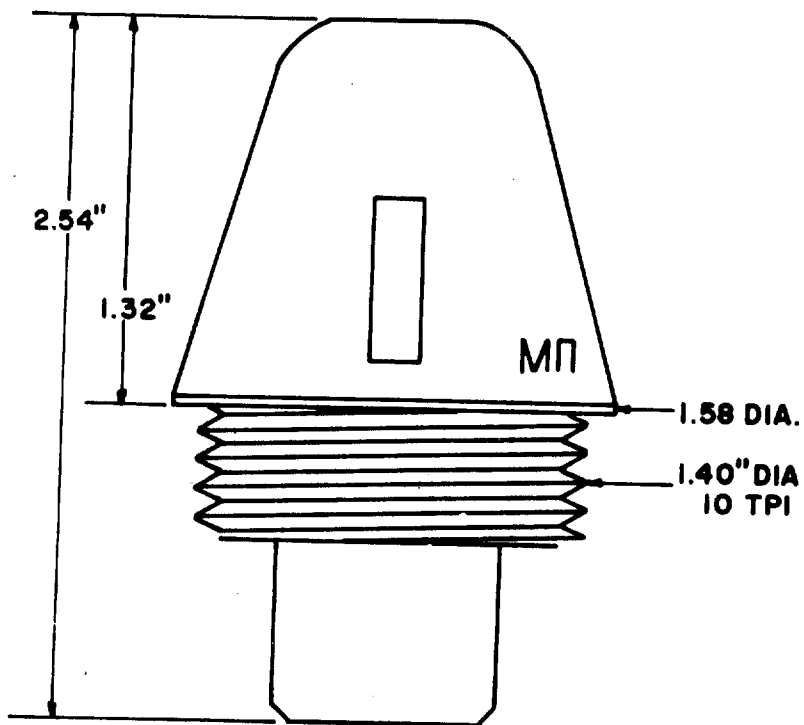

SOVIET POINT DETONATING IMPACT FUZE MODEL MP-82

This fuze is similar in construction to the MP fuze, from which it differs only by the increased resistance of its membrane. The MP-82 is interchangeable with the MP mortar fuze and is used in 82-mm mortar shells. This fuze may be used in the same shells and fired from the same weapons as the MP fuze. This fuze is considered "unsecured" by the Soviet safety classification.

3-65/3-66

a. General.

- (1) The RG-6 has been replaced by the later RGM and RGM-2 fuzes because its striker action is less sensitive than that of the other two fuzes and it is unsafe to fire when set for delay action. It is not to be used at temperatures below freezing, or in firing guns and howitzers with a full charge. The Soviets consider the fuze to be in the "safe" category, presumably because the explosive train is interrupted between the detonator and the booster until the projectile leaves the bore of the weapon. In the case of premature primer ignition at the delay setting, however, the powder delay element would burn until the explosive train was aligned, so that the projectile would burst dangerously close to the weapon.
- (2) The RG-6 differs in construction from the RGM and RGM-2 at several points. It has an elongated nose cap with a rounded top, into which the head of its striker extends; the other fuzes have a relatively short, flat-topped cap, a striker which does not extend beyond the nose of the fuze proper, and membranous metal cover cup designed to prevent air pressure from activating the fuze when it is fired without the nose cap. Another major difference is that the RG-6 has no safety device to prevent premature activation at the delay setting; the RGM and RGM-2 have been provided with a safety plunger to eliminate this drawback.
- (3) The different settings of the RG-6 give a fragmentation, high-explosive, ricochet, or delayed high-explosive effect.

<u>Setting</u>	<u>Action</u>
"0" w/o cap -----	instantaneous (Frag)
"0" w/cap -----	nondelay (HE)
"3" w/o or w/cap -----	delay (delayed HE or ricochet)

NOTE: The fuze cap may be either removed or left in place when the fuze setting is "3", since its influence at this setting is insignificant.

b. Characteristics.

Action ----- instantaneous, nondelay, and delay  
Loaded weight ----- 430 gm. (0.946 lb.)  
Body material ----- steel

c. Functioning.

(1) On firing, the arming sleeve (2) sets back, compresses the arming sleeve spring (3), and locks with the retaining ball sleeve (4). Simultaneously the inertia sleeve (17), overcoming the opposition of the prongs of the inertia pin safety clamp (18), sets back, compresses the inertia sleeve spring (19), and locks with the inertia pin (20). The springs (3) and (19) remain compressed until the shell leaves the bore of the gun, when they overcome the force of inertia. Then the arming sleeve spring moves the arming sleeve and the retaining ball sleeve forward, releasing the three retaining balls (11), and centrifugal force causes the balls to escape from their housings in the striker (1) so that they no longer prevent the movement of the striker or the primer holder (5). At the same time, the inertia sleeve spring moves the inertia sleeve forward, drawing the attached inertia pin out of its socket in the relay charge housing (16) and thereby unlocking the rotor body (14). The rotor body turns under the influence of the spiral spring (8) and brings the detonator (15) into alignment with the relay charge (9) leading to the booster (10), and comes to rest on a check pin.

(2) If the fuze is set to instantaneous action ("0"), with fuze cap removed, the striker (1) is driven rearward on impact with the target, overcoming the anticreep spring (12), and the firing pin strikes the primer (6). At the same setting, but with the fuze cap on, the primer holder and primer move forward, and the primer strikes the firing pin. In either case, the flash passes directly through an opening in the setting selector (13), and into the detonator in the rotor body. The detonation wave from the detonator travels through the relay charge and activates the booster.

(3) If the fuze is set for delayed action ("3"), the setting selector blocks the direct channel from the primer to the detonator, and the flash must pass to the detonator by way of the powder delay pellet (7). (The fuze cap has the same effect on the operation at the delay setting as at the instantaneous setting: without fuze cap, the firing pin moves rearward to strike the primer; with fuze cap, the primer moves forward to strike the firing pin.)

SOVIET POINT DETONATING IMPACT FUZE MODEL RG-6

d. Weapons and projectiles with which used.

Weapons	Projectiles
122-mm: howitzers M1910/30 M1909/37, and M1938(M-30); corps guns M1931 and M1931/37 (A-19)	122-mm HE -- F-460;F-460A;F460K; F-460N;F-460U Frag HE-- OF-462;OF-462A OF-462L;OF-462N
152-mm: howitzers M1909/30,M1938 (M-10), and M1943 (D-1); tank howitzer M1938/40; gun-howitzer M1937(ML-20); gun M1910/34; SP gun M1937/43 (ML-20S)	152-mm HE--F-533;F-533K;F-533L; F-533M;F-533N; F-533U Frag HE---OF-530;OF-530A Frag ----- O-530A

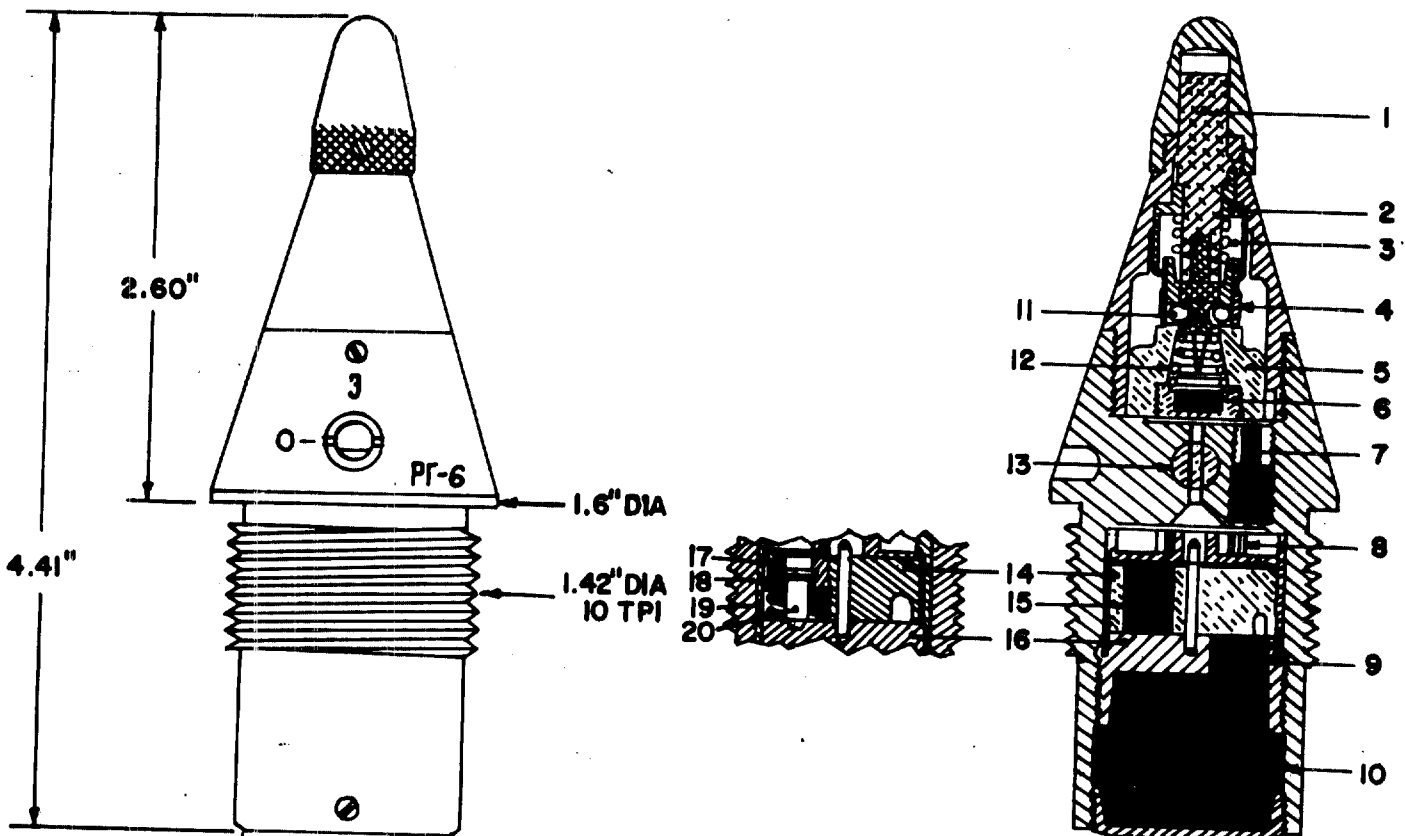

SOVIET POINT DETONATING IMPACT FUZE MODEL RGM

a. General. The RGM and RGM-2 fuzes have replaced the RG-6, which they closely resemble in design and functioning, largely because they are more sensitive than the RG-6 when set at instantaneous action and are boresafe at all three settings. The chief disadvantage of the RGM lies in the relatively high resistivity of its safety devices, which may prevent the fuze from arming when setback is insufficient ( a condition sometime occurring in howitzer fire with low charges). It is presumably for this reason that the Soviets, according to documentary evidence, have not issued the RGM with howitzer shells since 1949. The arming difficulties were corrected in the RGM-2. The body of the RGM may be either smooth-surfaced as depicted, or identical to that shown in the illustration of the RGM-2, so that the two fuzes may be distinguished externally only by the stamped model designation. The RGM is designed to provide fragmentation, high-explosive, ricochet, or delayed high-explosive effect, depending on the speed of action determined by the fuze setting and the presence or absence of the fuze cap, as indicated below.

<u>Setting</u>	<u>Action</u>
"0" w/o cap -----	instantaneous (Frag)
"0" w/cap -----	nondelay (HE)
"3" w/o or w/cap -----	delay (delayed HE or ricochet)

NOTE: The fuze cap may be either removed or left in place when the fuze setting is "3", since its influence at this setting is insignificant.

b. Characteristics.

Action ----- instantaneous, nondelay, and delay  
Loaded weight ----- 460 gm. (1.012 lb.)  
Body material ----- steel

c. Functioning.

(1) On firing, the arming sleeve (2) sets back, compresses the arming sleeve spring (3), and locks with the retaining ball sleeve (5). Simultaneously, the inertia sleeve (16), overcoming the opposition of the prongs of the inertia pin safety clamp (17), sets back, compresses the inertia sleeve spring (18), and locks with the inertia pin (19). The

SOVIET POINT DETONATING IMPACT FUZE MODEL RGM

springs (3) and (18) remain compressed until the shell leaves the bore of the gun, when they overcome the force of inertia. Then the arming sleeve spring moves the arming sleeve and the retaining ball sleeve forward, releasing the three retaining balls (6), and centrifugal force causes the balls to escape from their housings in the striker (4) so that they no longer prevent the movement of the striker or the primer holder (8). At the same time, the inertia sleeve spring moves the inertia sleeve forward, drawing the attached inertia pin out of its socket in the relay charge housing (12) and thereby unlocking the rotor body (11). The rotor body turns under the influence of the spiral spring (10), brings the detonator (21) into position opposite the relay charge (23) leading to the booster (13), and comes to rest on a check pin.

(2) If the fuze is set to instantaneous action ("0"), with fuze cap removed, the striker (4) is driven rearward on impact with the target, and the firing pin (14) strikes the primer (9). At the same setting, but with fuze cap on, the primer holder and primer move forward, shearing the claws of the primer holder retainer (7), and the primer strikes the firing pin. In either case, the flash passes directly through an opening in the setting selector (15), and into the detonator (21) in the rotor body. The detonation wave from the detonator travels through the relay charge (23) and activates the booster.

(3) If the fuze is set on delayed action ("3"), the setting selector blocks the direct channel from primer to detonator, and the flash must pass to the detonator by way of the powder delay pellet (22). (The fuze cap has the same effect on the operation at the delay setting as at the instantaneous setting: without fuze cap, the firing pin moves rearward to strike the primer; the primer moves forward to strike the firing pin when the cap is used.) A safety plunger (20) prevents muzzle bursts at this setting, should the fuze primer ignite while the shell is in the bore of the weapon. Premature action of the primer forces the safety plunger to shear its retaining pin, move rearward, and immobilize the rotor body, thereby preventing the rotor body from moving the detonator into alinement with the relay charge and booster. Accordingly, the flash travels from the powder delay pellet to the detonator but, unable to pass from the detonator to the relay charge and booster, cannot activate the projectile.

d. Weapons and projectiles with which used.

Weapons	Projectiles
100-mm: field (AT) gun M1944 (BS-3); SP gun M1944 (D-10S)	100-mm HE ----- F-412

SOVIET POINT DETONATING IMPACT FUZE MODEL RGM

Weapons (Cont)

Projectiles (Cont)

107-mm: corps guns M1910/30 and M1940 (M-60)

107-mm HE ----- F-422L;F-422M  
Frag HE ----- OF-420

122-mm: howitzers M1910/30, M1909/37, and M1938 (M-30); corps guns M1931 and M1931/37(A-19); tank gun M1943(D-25); SP guns M1944(D-25S) and M1931/44(A-19S)

122-mm HE ----- F-460; F-460K; F-460N; F-460U  
Frag HE ----- OF-462; OF-462A  
OF-462L; OF-462M  
OF-471; OF-471N

152-mm: howitzers M1909/30, M1938(M-10), and M1943(D-1); guns M1910/34 and M1935; gun-howitzer M1937 (ML-20); SP gun M1937/43(ML-20S)

152-mm HE ----- F-533; F-533K; F-533L; F-533M; F-533N; F-533U; F-540Sh; F-542  
Frag HE OF-530; OF-530A; OF-540

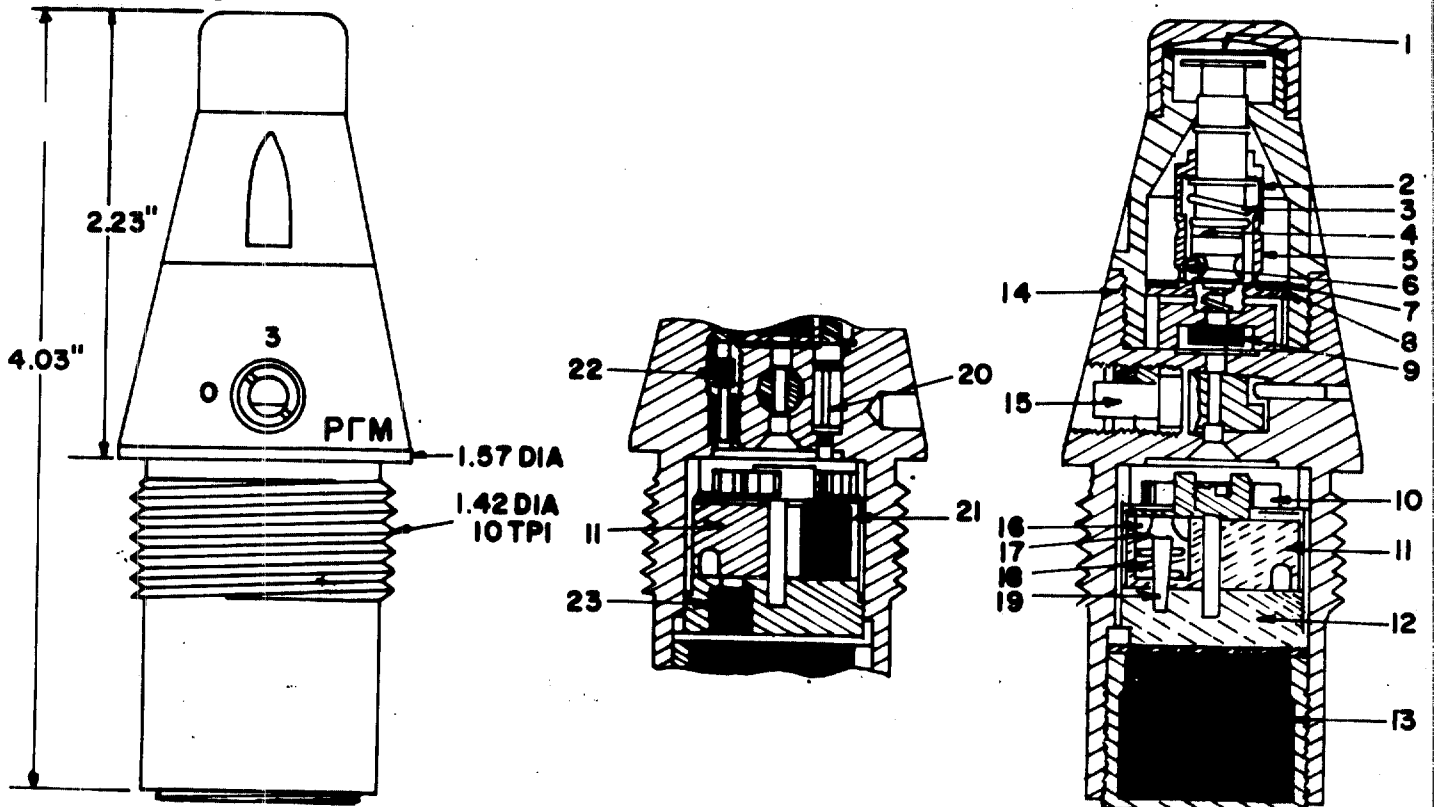

3-73/3-74

SOVIET POINT DETONATING IMPACT FUZE MODEL RGM-2

a. General. The RGM-2 (Rdultovskogo, Golovnoy, Membranny, 2-y Obrazets: literally, "Rdultovskiy (designer's name), Point detonating, Membrane, Model 2") differs structurally from the RGM only in the percussion safety mechanism and in the rotor body locking device. This objectionable rigidity (and the consequent high resistance to setback) of these parts in the RGM, which led to arming failures in low-velocity fire, has been corrected in the RGM-2 principally by using springs instead of rigid parts. According to a Soviet publication, the RGM-2 is used in fragmentation, fragmentation high-explosive, and high-explosive shells for guns and howitzers of 122-mm caliber and above. The fuze is boresafe, and falls under the Soviet classification "safe" because the explosive train from the detonator to the booster is interrupted until the fuze arms. Like the RGM, the RGM-2 provides fragmentation, high-explosive, ricochet, or delayed high-explosive effect. The effect is determined by the fuze setting and by the use or omission of the fuze cap, as shown below.

<u>Setting</u>	<u>Action</u>
"0" w/o cap	instantaneous (Frag)
"0" w/cap	nondelay (HE)
"3" w/o or w/cap	delay (delayed HE or ricochet)

NOTE: The fuze cap may be either removed or left in place when the fuze setting is "3", since its influence at this setting is insignificant.

b. Characteristics.

Action ----- instantaneous, nondelay, and delay  
Loaded weight ----- 470 gm. (1.034 lb.)  
Body material ----- steel

c. Functioning. The functioning of the RGM-2 is identical to that of the RGM.

SOVIET POINT DETONATING IMPACT FUZE MODEL RGM-2

d. Weapons and projectiles with which used.

Weapons	Projectiles
122-mm: howitzer M1938(M-30); corps guns M1931 and M1931/37(A-19); tank gun M1943(D-25); SP guns M1944 (D-258) and M1931/44 (A-19S)	122-mm Frag-HE ——— OF-462; OF-471N
152-mm: howitzers M1938(M-10) and M1943 (D-1); tank howitzer M1938/40; gun M1910/34; gun-howitzer M1937 (M-20); SP gun M1937/43 (M-20S)	152-mm Frag-HE ——— OF-530; OF-530A; OF-540

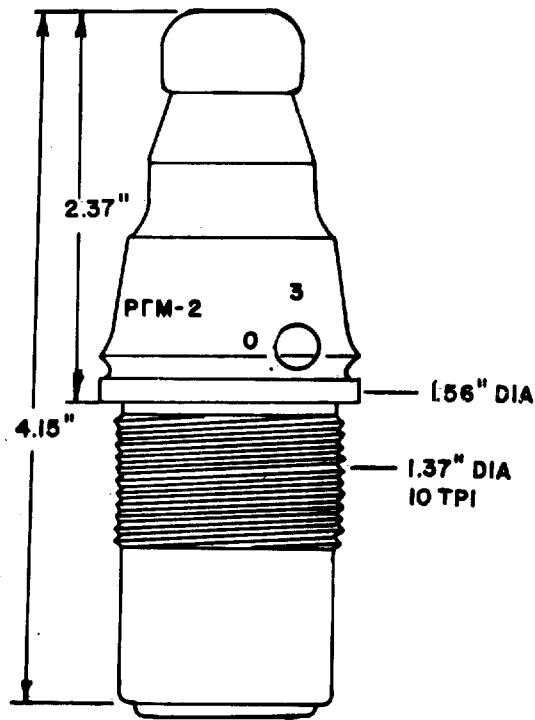

SOVIET POINT DETONATING IMPACT FUZE MODEL RGM-3

The RGM-3 fuze is known to exist, but no information as to its design and functioning is available. It is believed likely, however, that the RGM-3 is similar in construction and functioning to the RGM-2 fuze.

3-77/3-78

SOVIET POINT DETONATING IMPACT FUZE MODEL UGT

a. General. The UGT fuze (Universal'nyy Golovnoy, Tetrilovyy: literally, "Universal, Point detonating, Tetryl") is a nondelay fuze of early Soviet design which has been replaced by the Model UGT-2 fuze. HE projectiles of old design are currently using the UGT; however, new model projectiles now use the UGT-2. The UGT is termed "universal" because of its versatility of use in projectiles of varying caliber. Prior to firing, the primer carrier (5) is held in the rearmost portion of the fuze by the anticreep spring (1) so that the primer is isolated from the detonator (6). The fuze is considered "safe" by Soviet standards prior to firing. In the armed position this fuze is extremely sensitive and a very light blow on its nose may detonate it. It is recommended that any dud projectiles armed with this fuze be blasted in place.

b. Characteristics.

Action ----- nondelay

Loaded weight ----- 330 gm. (0.726 lb.)

Body material ----- steel

c. Functioning. On firing, setback forces the stirrup (3) rearward over the primer carrier clamping spring (4) which springs outward behind the shoulders on the inner surface of the stirrup (3) and thus locks the stirrup to the primer carrier (5). On impact, the stirrup with the carrier locked to it, and the primer (7) which is firmly affixed to the end of the carrier, drive forward and bring the primer into position in the center of the detonator (6). On striking the firing pin (2), the primer is activated, and in turn activates the detonator (6), exploding the projectile filler.

d. Weapons and projectiles with which used.

Weapons	Projectiles
107-mm: corps guns M1910/30, M1940 (M-80), and M1941	107-mm HE ----- F-422L
152-mm: gun M1910/34; gun-howitzer M1937 (ML-20)	152-mm HE ----- F-542G
203-mm: howitzer M1931 (B-4)	203-mm HE ----- F-621
305-mm: howitzer M1940 (BR-18)	305-mm ----- ?

SOVIET POINT DETONATING IMPACT FUZE MODEL UGT

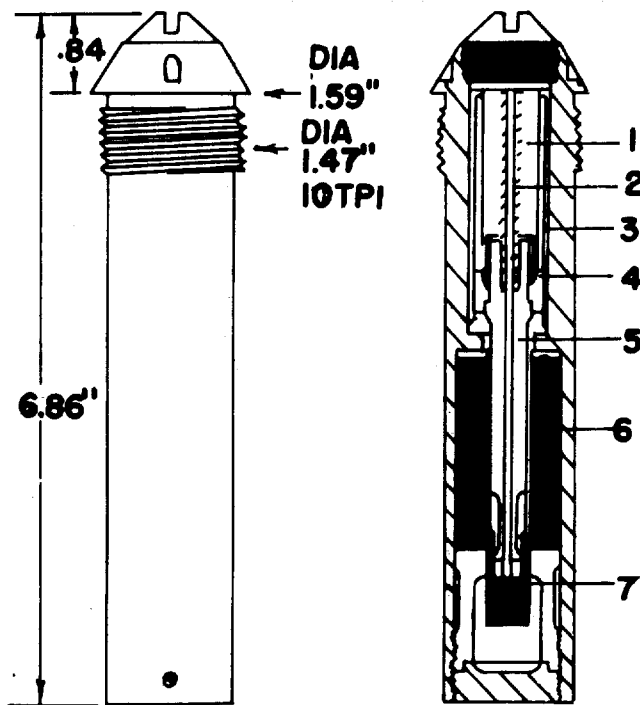

SOVIET POINT DETONATING IMPACT FUZE MODEL UGT-2

a. General. The UGT-2 fuze (Universal'nyy, Golovnoy, Tetrilovyy, S Dvumya Ustanovkami: literally, "Universal, Point detonating, Tetryl, With two settings") was designed for use with high-explosive and fragmentation high-explosive projectiles of 76-mm, 107-mm, 122-mm, and 152-mm caliber. The fuze is capable of nondelay action with fuze cap removed, and delay action (approximately 0.01 second) with the fuze cap attached. The fuze cap may be removed by means of a tool inserted in a slot in the cap. This fuze is boresafe and armed by setback action; it differs from the UGT chiefly in having a fuze cap which may be removed to vary the action, a firing pin attached to a heavy striker head, and an arming spring that forces the primer carrier forward on arming, there-by positioning the primer just under the firing pin.

b. Characteristics.

Action ----- nondelay or delay  
 Loaded weight ----- 330 gm. (0.726 lb.)  
 Body material ----- steel

c. Functioning. The functioning of the UGT-2 is essentially the same as that of the UGT fuze.

d. Weapons and projectiles with which used.

76-mm: divisional guns M1902/30, M1933, M1936 (F-22), M1938/39, M1939 (USV), & M1942 (ZIS-3)	76-mm HE ----- F-354U
107-mm: corps guns M1910/30 and M1941	107-mm HE ----- F-420U Frag-HE ----- OF-420U Smoke ----- D-422; D-422U
122-mm: tank gun M1943 (D-25); corps guns M1931 and M1931/37 (A-19); SP gun M1944 (A-19S); howitzers M1910/30 and M1909/37	122-mm HE ----- F-460K; F-460N; F-460U
152-mm: gun M1910/34, M1910/30; gun-howitzer M1937 (ML-20); howitzers M1909/30 and M1910/37	152-mm HE - F-533; F-533K; F-533L F-533M; F-533N; F-533U; F-542ShU; F-542U

SOVIET POINT DETONATING IMPACT FUZE MODEL UGT-2

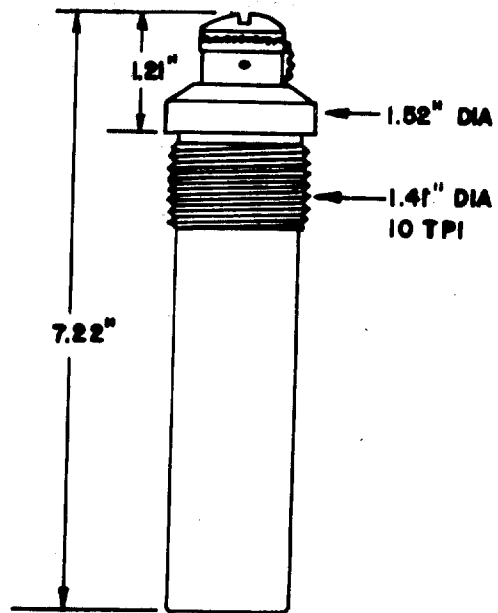

SOVIET POINT DETONATING IMPACT FUZE MODEL UGT-3

This fuze is the third model of the UGT series and is similar in design and functioning to the UGT-2 fuze. The UGT-3 differs from the UGT-2 only in the shape of the nose.

3-83/3-84

SOVIET POINT DETONATING IMPACT FUZE MODEL V-25

a. General. The Soviet V-25 is a selective superquick or delay point detonating fuze employed in the 140-mm rocket. The V-25 employs graze sensitive weights and detonator carrier producing impact inertia-non-delay functioning when impacting at flat angles. The entire fuze is made of cadmium plated steel, except for the selector assembly which is brass. The steel body is heavy and robust and is capable of attacking reinforced structures. An indication of its penetration capabilities is the 1-second long delay feature. The fuze is well constructed making extensive use of plating of set-back and centrifugal detents as well as plastic sealing rings at all fuze body openings rendering the fuze body completely waterproof.

The V-25 is considered bore safe and provides handling and shipping safety. The fuze nose is protected by a shipping cap (1) that may or may not be removed for firing. The striker head and firing pin assembly (11) are maintained in the upper part of the fuze by the striker spring (2). The striker is held away from the detonator (16) by two centrifugal detents (14). The detents (14) are maintained under the firing pin (11) by the detent springs (13). The detents and springs are loaded through the closing cap (12) which is sealed by a plastic ring. The centrifugal detents (14) are further held in the locked position by two set-back detents (3) and springs (4). The graze sensitive weights (17) cam the detonator carrier (6) upward into the firing pin (11) upon flat impact. The delay assemblies (19) consist of non-gaseous powder pressed into threaded housings that screw into the fuze body. The selector (18) is a cylindrical piece of brass in which two holes have been drilled. The superquick hole provides a straight flash channel from the upper detonator (16) to the lower detonator (7); the second hole is the short delay channel (21). It is drilled at a 45 degree angle and when the selector is turned to "M", it accepts the flash from the upper detonator and transmits it to the short delay pellet which burns for 0.5 seconds. With the selector set on , the central flash hole is completely blocked. This permits the long delay pellets (20) to be ignited and produce their 1-second delay. It should be noted that the long delay pellets are ignited during superquick and short delay action, but are not permitted to complete their function prior to detonation of the fuze.

<u>Setting</u>	<u>Action</u>
"0"	----- superquick
"S"	----- long delay (1.0 second)
"M"	----- short delay (0.5 second)

SOVIET POINT DETONATING IMPACT FUZE MODEL V-25

b. Characteristics.

Action ----- superquick or delay

Loaded weight ----- 605 grams (1.30 lbs.)

Body material ----- steel

c. Functioning. When the rocket is fired, setback causes the two setback detents (14) to move downward against their springs, unlocking their centrifugal weights (14) which move outward against their springs (13) by centrifugal force. As the centrifugal detents (14) move outward the positive block is removed from the firing pin (11). The striker is prevented from firing the detonator by the striker spring (2). When setback ceases, the centrifugal detent blocking cup (15) rises under the influence of its spring to prevent the centrifugal detents from returning to their original positions and blocking the striker. The fuze is now armed and will function upon impact or grazing action. Upon impact, the striker assembly (11) is driven rearward. Simultaneously, the graze weights (17) slide laterally camming the detonator carrier (6) forward. The firing pin pierces the detonator, initiating the explosive train. If the fuze strikes a target at a low angle, the striker assembly (11) may not be driven rearward. The graze weights (17) move laterally camming the detonator carrier (6) upward. The detonator carrier overcomes the resistance of the carrier spring (5) and impales itself on the detonator, initiating the explosive train.

d. Weapons and projectiles with which used.

140-mm: Soviet rocket launcher  
Model ?

140-mm HE-Frag ----- M140F

SOVIET POINT DETONATING IMPACT FUZE MODEL V-25

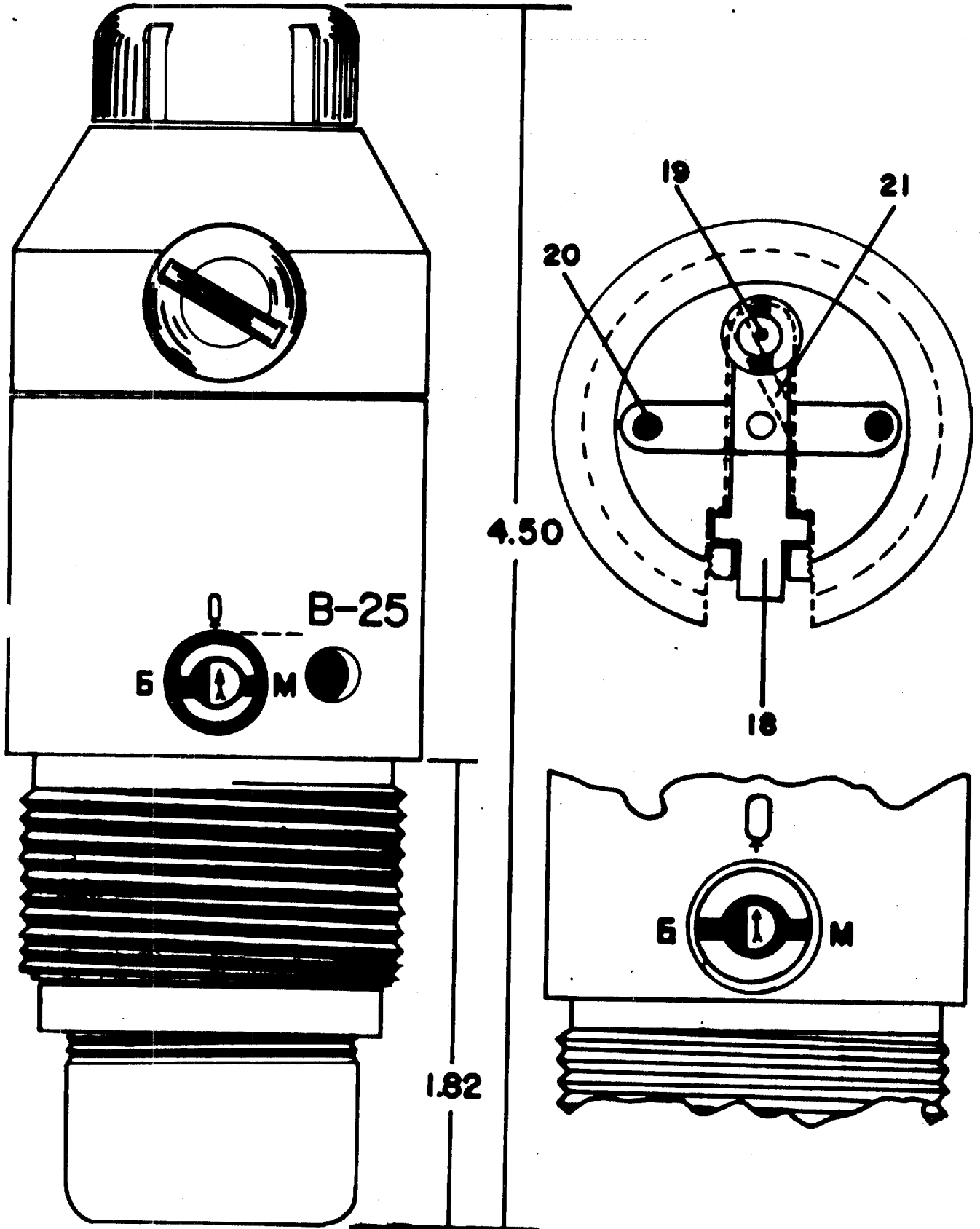

SOVIET POINT DETONATING IMPACT FUZE MODEL V-25

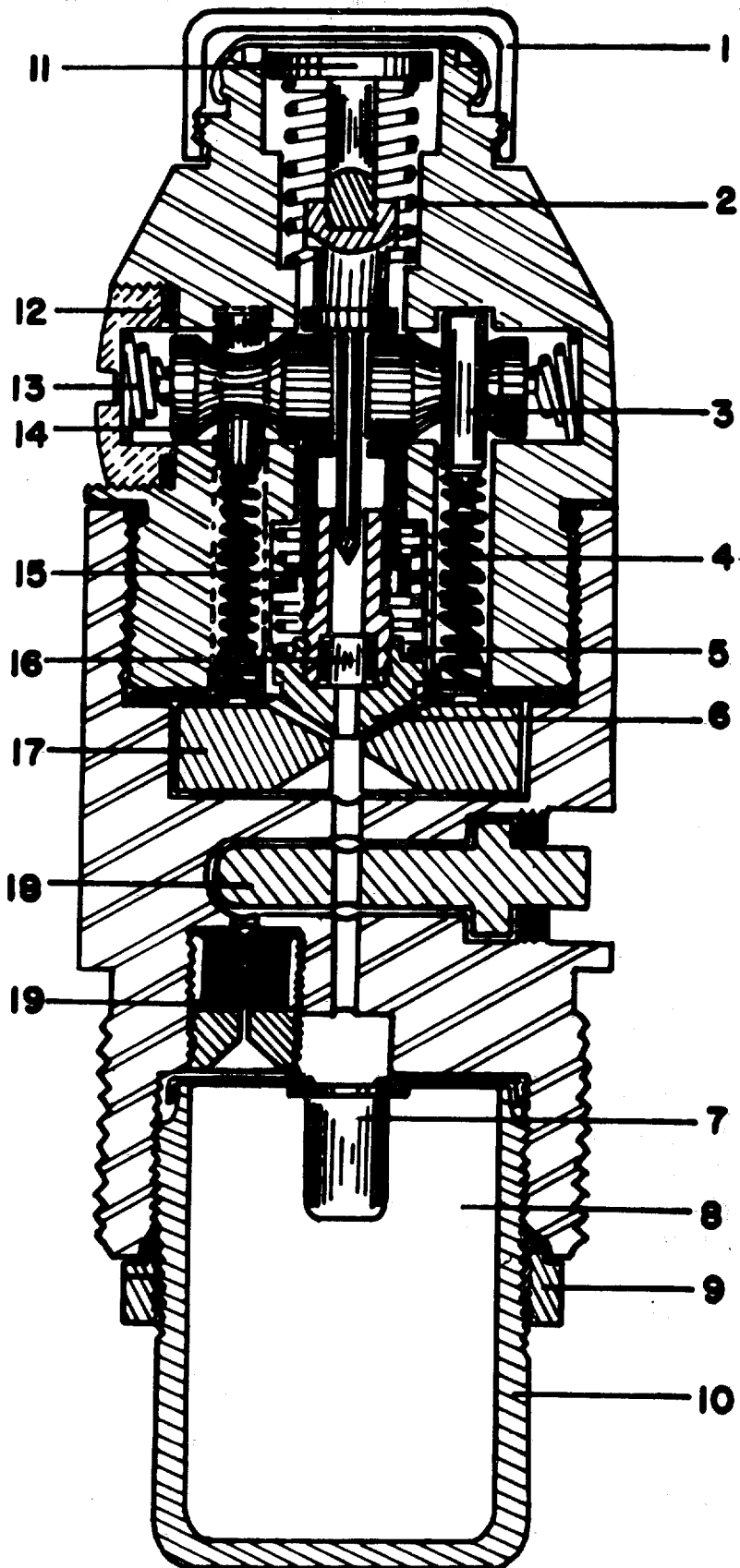

SOVIET POINT DETONATING IMPACT FUZE MODEL V-229

a. General. The V-229 is an instantaneous, nose-percussion-type fuze of conventional design, used only on HE,AT projectiles fired from 122-mm howitzers. The fuze body is plastic. Three check balls, positioned above the stirrup to prevent forward movement of the firing pin, and three steel rollers, positioned at the lower end of the striker to prevent rearward movement, make this fuze mechanically boresafe. The fuze is extremely sensitive when armed and caution should be exercised in handling it. To remove it from the dud or an unfired projectile, loosen the grub screw which secures it to the projectile nose, and unscrew the fuze (left-hand thread). A visual examination will not reveal whether the fuze is armed or unarmed.

b. Characteristics.

Action ----- instantaneous

Loaded weight ----- ?

Body material ----- plastic

c. Functioning. On firing, the stirrup (4) sets back and compresses the arming spring (5) and, at the same time, frees the check balls (3) from the recess and allows them to drop down into the fuze body. This frees the stirrup for forward movement, although it is momentarily held rearward by the force of inertia. After the projectile has left the gun tube, the arming spring (5) decompresses and forces the stirrup forward until it contacts the under surface of the striker head (2). This frees the safety rollers (6) and permits them to drop down into the fuze body, freeing the striker for rearward movement. On impact, the foil cap (1) is ruptured, the striker is driven downward, forcing the firing pin (7) into the detonator assembly (8), and exploding the projectile.

d. Weapons and projectiles with which used.

Weapons	Projectiles
122-mm: howitzers M1910/30, M1909/37, and M1938 (M-30)	122-mm HE,AT ----- BP-460A

SOVIET POINT DETONATING IMPACT FUZE MODEL V-229

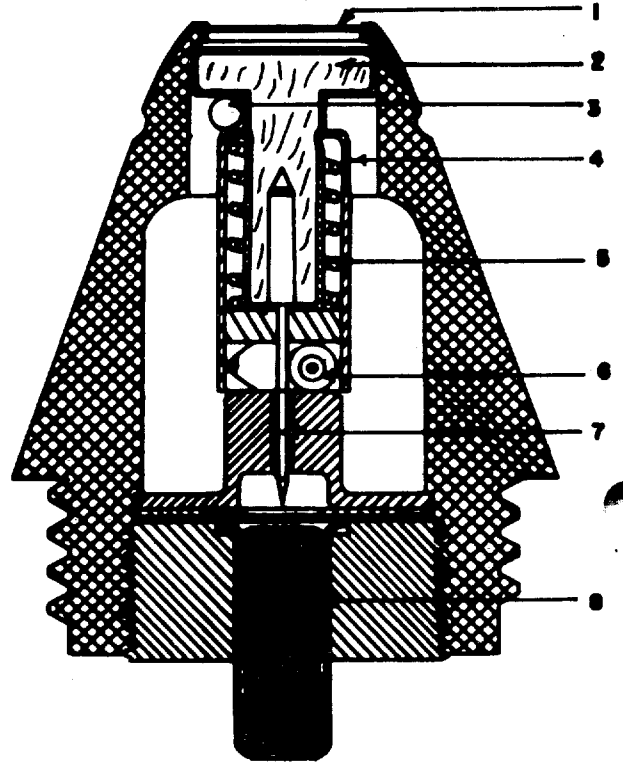
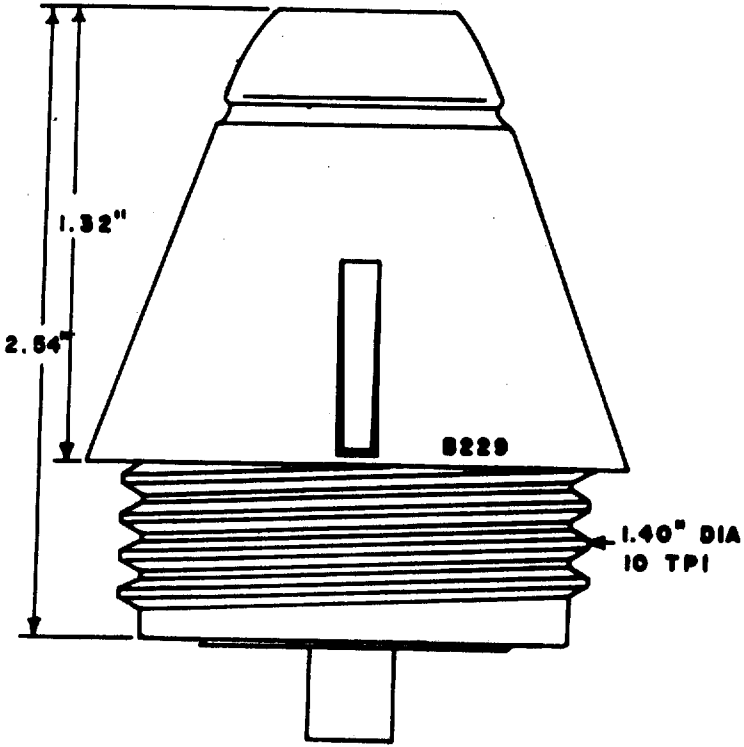

SOVIET POINT DETONATING IMPACT FUZE V-429

a. General. The Soviet V-429 is the latest product in the evolution of the Soviet RG-6 and RGM series fuzes. The V-429 contains a firing pin arming mechanism identical in principal to that seen in the Soviet M-50 mortar fuze and in the Soviet V-229 fuze. The selector spindle is the same as that employed on the RGM. The coiled, flat spring powered, out-of-line detonator system is the same as that employed on the Soviet D-1 and RGM series fuzes. The setback operated rotor unlocking system is identical with the one used on the later version of the RGM-2. The Soviet V-429 is armed only by setback.

The Soviet V-429 closely resembles the RGM series fuzes in that it is machined from steel, the upper body is cadmium plated while the lower body is blued. The entire fuze is sprayed with varnish for corrosion protection. All openings in the fuze are sealed by vinyl sealing rings. The selector is made waterproof through a compound packing gland. Externally, The Soviet V-429 differs from the RGM in having a slightly longer booster containing 12.0 grams of tetryl and wax as well as a booster lock ring.

The safety plunger (9) prevents muzzle bursts should the primer (8) premature. When the primer fires, the gasses drive the plunger (9) downward shearing the pin (10). The shank of the plunger prevents the lug on the rotor spring mechanism (11) from turning the rotor (20) to align the detonator with the booster lead (16). In this case the fuze will be a dud. The safety plunger (9) also functions when the primer is fired to lock the rotor (20) in the armed position. This prevents the rotor (20) from bouncing out of line upon impact so that delay functioning will be normal.

b. Characteristics.

Action ----- Instantaneous and delay  
Loaded weight ----- 434 grams (0.95 lb)  
Body material ----- Steel

c. Functioning. Prior to firing, a selection is made of the desired fuze functioning. The nose cap (1) may be removed for superquick functioning or left in place for non-delay functioning. The selector is turned to the "0" position for superquick or to the "3" position for a delay setting.

Upon setback, the setback sleeve (5) moves down, compressing its spring (4), and releasing the locking ball (3). The setback collar (13) moves downward against its spring (15) and the lock pin (14) releases its pressure on the ball (12). Setback and centrifugal force causes the ball (12) to move into the collar (13) cavity. As acceleration diminishes,

the setback sleeve (5) moves forward, powered by its spring (4) into the space occupied by the locking ball. This uncovers the firing pin locking balls (6), which are removed from their cavities by centrifugal force. The lock pin (14) is also forced upward by its spring withdrawing its shank from the lock pin hole in the booster lead disc. This unlocks the out-of-line rotor (20). The rotor (20) is then rotated by the clock type spring (11) aligning the detonator with the booster lead (16). The stop pin (21) limits the travel of the rotor to assure it stops in line with the detonator and booster lead.

Upon impact, the firing pin (2) is driven into the primer (8) if the shipping cap is removed. If the cap remains in position the primer cover moves forward impaling the primer (8) on the firing pin (7). When the primer fires the flash passes through the flash channel and ignites the delay element (17) and drives the safety plunger (9) downward shearing its pin (10). The safety plunger locks the rotor in the armed position. If the selector (18) is set for superquick functioning, the primer flash initiates the detonator in the rotor (20) which in turn functions the booster lead and booster. If the selector (18) is set on delay the flash channel is blocked and the delay initiates detonator functioning.

d. Weapons and projectiles with which used.

Weapons	Projectiles
122mm: Gun D-74 Gun - Howitzer M1963 Gun M1931/37 (A-19)	122mm: HE-Frag. OF-472 HE-Frag. OF-462
130mm: Gun M46	130mm: HE-Frag. OF-482M
152mm: Gun ML-20 Gun D-20	152mm: HE-Frag. OF-540

SOVIET POINT DETONATING IMPACT FUZE V-429

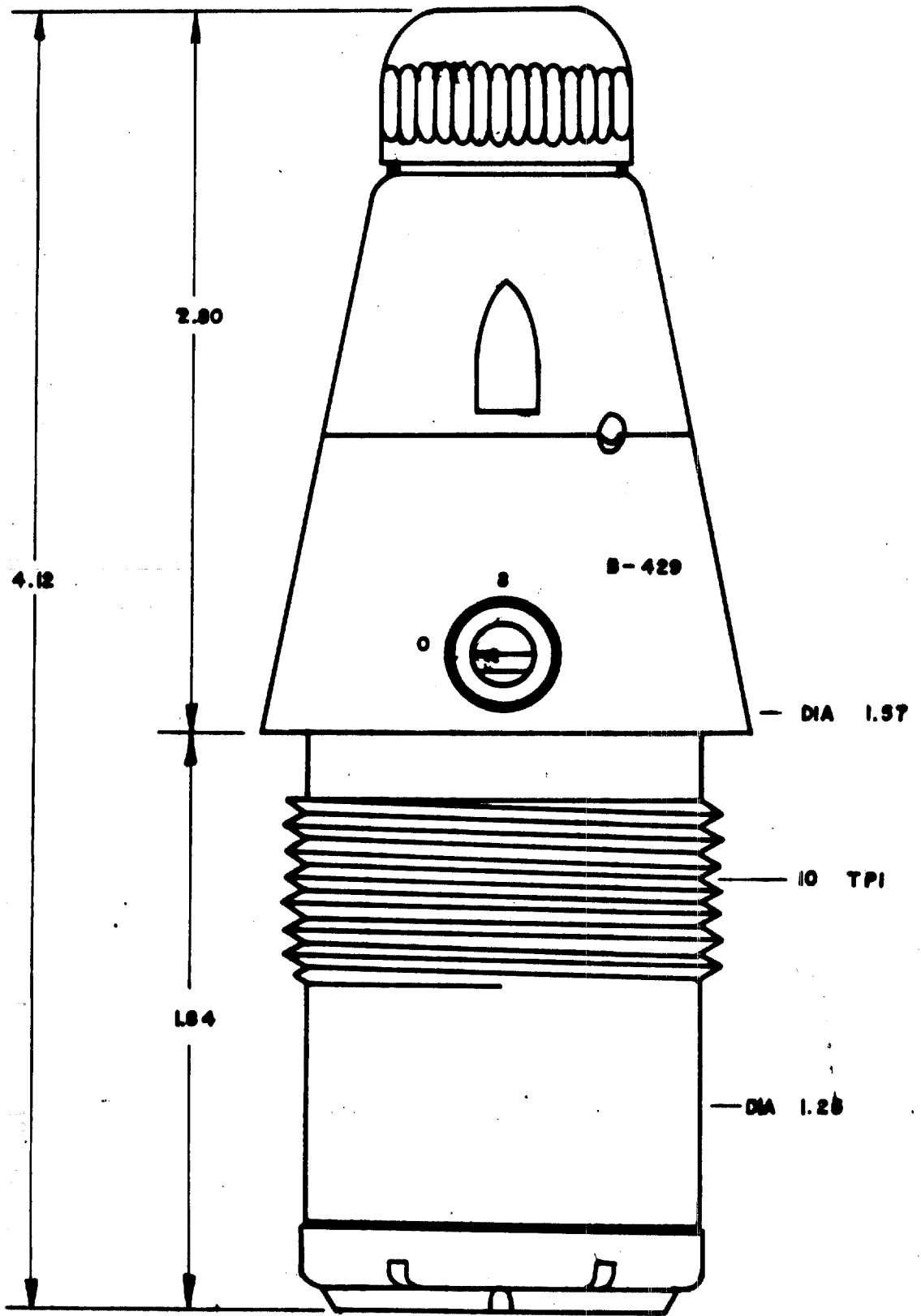

3-93

SOVIET POINT DETONATING IMPACT FUZE V-429

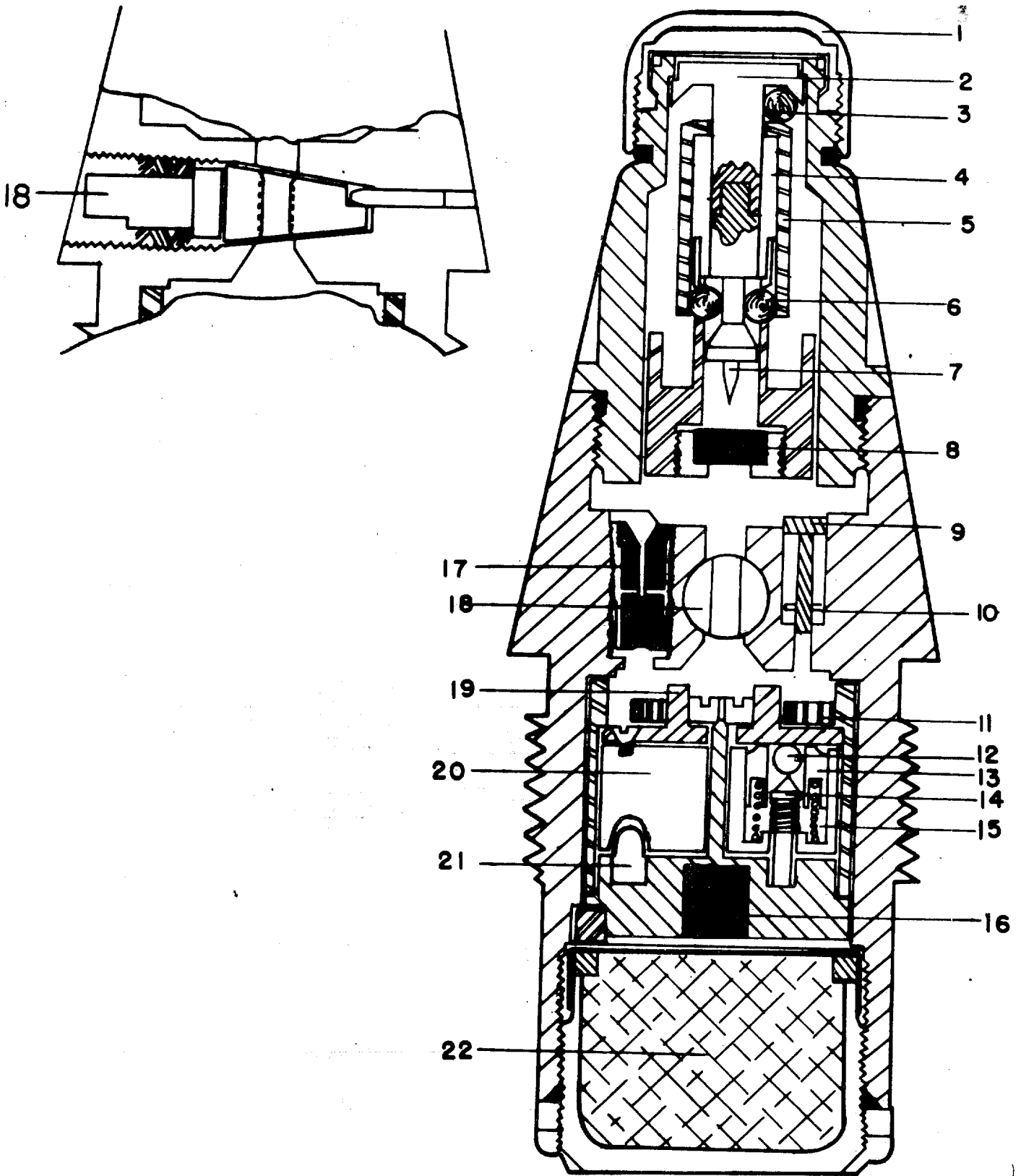

SOVIET POINT DETONATING IMPACT FUZE MODEL 3GT

a. General. The 3GT fuze (Golovnoy, Tetrilovy, 3-y Obrazets: literally, "Point detonating, Tetryl, 3rd Model") is used on old high-explosive projectiles. It has been replaced on later model projectiles by the UGT series of fuzes (UGT, UGT-2, and UGT-3). The 3GT fuze is painted black. When the fuze is properly seated, only its nose plug (1) protrudes from the projectile (approximately one-half inch). The fuze is considered semisecure by Soviet standards because the primer is isolated from the detonator until the projectile leaves the bore of the gun.

b. Characteristics.

Action ----- nondelay

Loaded weight ----- 720 grams (1.58 lbs)

Body material ----- steel

c. Functioning. On firing, the stirrup (3) sets back, overrides the stirrup clamp (4), and is locked to the striker (5). On impact, the stirrup (3), striker (5), firing pin (6), primer carrier (8), the primer (9) set forward, compressing the anticreep spring (2). When the spring is fully compressed, the sleeve, striker, and firing pin stop while the primer continues forward, forcing the pellet against the firing pin and igniting the primer which successively actuates the detonator (7) and explodes the projectile.

d. Weapons and projectiles with which used.

Weapons	Projectiles
76-mm: divisional guns M1902/30, M1933 M1936(F-22), M1939(USV), and M1942(ZIS-3); tank guns M1927/32, M1938/39 (L-11), M1939 (F-32), M1940 (F-34), and M1941 (ZIS-5); mountain gun (howitzer) M1909; regimental gun (howitzer) M1927	76-mm HE ----- F-354;F-354G

SOVIET POINT DETONATING IMPACT FUZE MODEL 3GT

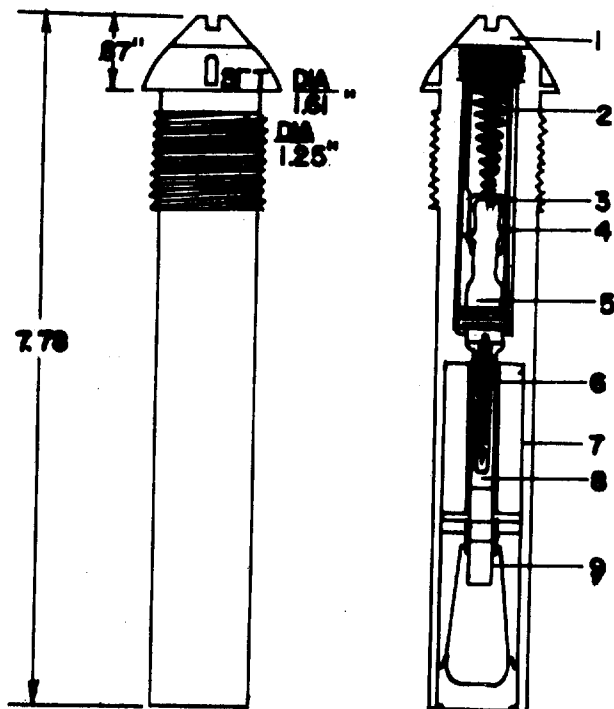

SOVIET POINT DETONATING IMPACT FUZE MODEL 4GT

a. General. The 4GT is a single action, short delay-type fuze which has been replaced by the UGT-series fuzes in current use. Information relative to this fuze is very limited. The fuze is used in old-type high-explosive projectiles of the 152-mm and 203-mm caliber. The safety pin (1) must be removed before the projectile is fired. The powder charge (9) is sealed off from the primer (5) by a lead washer and a shaft (8).

b. Characteristics.

Action ----- short delay

Loaded weight ----- ?

Body material ----- ?

c. Functioning. On firing, the upper firing pin (3) sets back and is locked in position by the clip (2). During flight, the primer holder (6) is held in position by the anticreep spring (4). On impact, the primer holder moves forward because of inertia, and impinges the primer (5) on the point of the upper firing pin (2). The flash from the primer (5) passes through the flash channel (7) and ignites the powder charge (9). The gases produced by the burning of the powder charge forces the firing pin (10) into the detonator assembly (11). The action of the detonator causes the booster (12) to explode, thus actuating the main charge of the projectile.

d. Weapons and projectiles with which used.

	Weapons	Projectiles
152-mm:	guns M1910/30 and M1910/34; gun-howitzer M1937 (ML-20)	152-mm HE ----- F-542G;F-542ShG; F-542Sh
203-mm:	howitzer M1931 (B-4)	203-mm HE ----- F-621G

SOVIET POINT DETONATING IMPACT FUZE MODEL 4GT

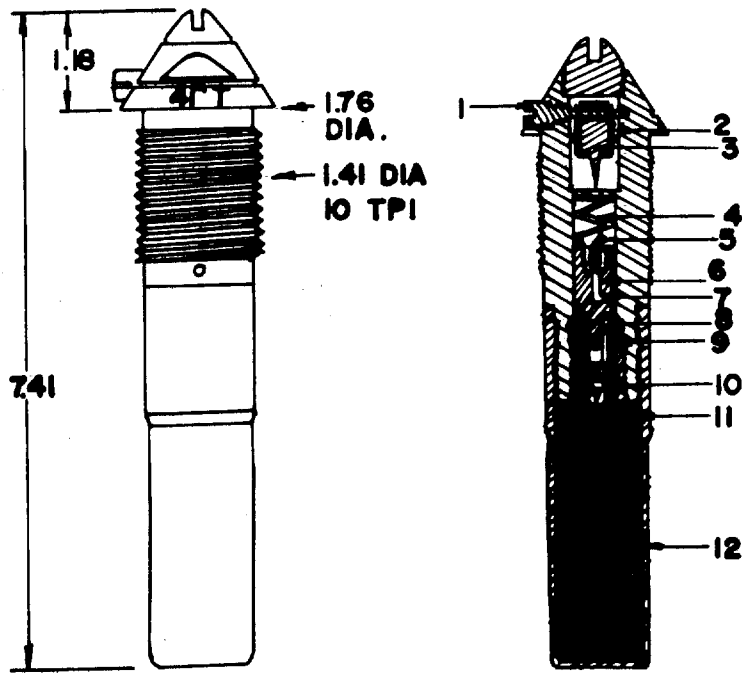

CHAPTER 4

CHINESE COMMUNIST POINT DETONATING FUZES

4-1.1

## CHINESE COMMUNIST POINT DETONATING FUZES

The greater population of ChiCom fuzes, regardless of class, have been direct copies of standard Soviet designs. However, a trend toward indigenous fuze designs has been noted. This is manifest in artillery calibers peculiar to the ChiComs. Where common caliber and projectile design exist between the ChiComs and Soviet, the Soviet fuze copy is normally employed.

In all cases workmanship has been excellent, indicating careful adherence to quality control procedure and employment of machine tools to western standards. Soviet fuze design philosophy, including environmental proofing, has been carefully incorporated into ChiCom fuze designs and workmanship. This reflects mastery of intricate machine tools, plating, plastics and assembly line procedures.

Those fuzes that are direct copies of Soviet fuzes, are in practically every case exact copies, down to identical tool marks. In these cases it is quite evident that Soviet drawings and Soviet built machine tools and dies have been employed to produce the fuze. The only departure from Soviet ordnance drawings are in the fuze markings.

Chinese Communist fuze designations at first appear to have no meaning. The Arabic number is simply a type designation. The key lies in the Chinese character that precedes the Arabic number. These characters are sometimes abbreviations of more complex Chinese characters. In other cases the characters represent a phonetic that resembles the Soviet spoken word. For example, mortar fuzes that are copies of the Soviet M series have a Chinese character that translates into "MU" ("EM in English") which is as close as the Chinese phonetic can come to the Russian Cyrillic sounds. A second example is the Chinese character appearing on their copy of the Soviet V-429 fuze. The character represents "FU" phonetically which approximates the "V" sound.

There are some designation markings on copies of Soviet fuzes, appearing both in Chinese characters and English type letters, that have not been deciphered. This may represent a new type designation system, but only one fuze possessing this type designation has been examined.

The Viet Nam conflict caused large quantities of Soviet and ChiCom "Sanitized" ordnance to be produced. The ChiComs produced weapons and ammunition with no designations, lot numbers, or manufacturing dates at all, or exerted great effort to grind this information off the fuzes. Where this was done on metallic fuzes, the markings were restored by etching and appear in this report.

A direct comparison of current ChiCom fuzes with those of Korean war vintage show remarkable advances in design and quality. Currently, ChiCom fuzes appear on a direct par with all other countries. The greater portion of ChiCom fuzes are direct copies of Soviet fuzes, but this does not detract from ChiCom workmanship or quality.

CHICOM POINT INITIATING BASE DETONATING IMPACT FUZE TYPE UNKNOWN

a. General. The ChiCom fuze for the 57-mm HEAT projectile is a centrifugally armed, point detonating fuze with a superquick action. Externally, the ChiCom fuze resembles the U.S. 57-mm HEAT fuze. Internally, the fuzes are vastly different. Functioning of the ChiCom fuze is almost identical with the ChiCom type 57 and early Type 53 fuzes. It has brass centrifugal detents that are mated together and they lock each other in position. They are retained in the unarmed position by a brass, leaf type, centrifugal spring. A wooden firing pin plunger transmits the force of impact to a brass firing pin. The firing pin plunger transmits the impact to a brass firing pin. The firing pin is maintained forward in its cavity, away from the primer, by a spring. The 57-mm RR fuze is machined from a solid block of aluminum and is assembled entirely from threaded components except for the nose diaphragm disc. There is no preparation for firing required.

b. Characteristics.

Action ----- Instantaneous  
Loaded weight ----- 175 grams (0.38 lbs)  
Body material ----- Aluminum

c. Functioning. Upon firing, setback seats the firing pin (2) firmly on the centrifugal detents (4) and restrains any outward rotation. After setback decreases, centrifugal forces cause the detents (4) to rotate about their pins against the tension of the centrifugal spring (3), which encircles the detents (4). When the noses of the detents (4) reach their outermost travel, they tend to engage the rear of the detent in front of it. As spin decreases, the centrifugal spring attempts to force the detents inward and become locked in the open position. The firing pin is maintained in the upper end of its cavity by the firing pin spring. Upon impact, the wooden firing pin plunger (1) forces the firing pin (2) downward into the primer (6). The primer flashes into the detonator (7), which, because of its shaped charge design, sends a "spit-back" jet of incandescent particles into the base detonator of the HEAT projectile.

d. Weapons and projectiles with which used.

57-mm: ChiCom Type 36 RR

57-mm HEAT ----- Type ?

CHICOM POINT INITIATING BASE DETONATING IMPACT FUZE TYPE UNKNOWN

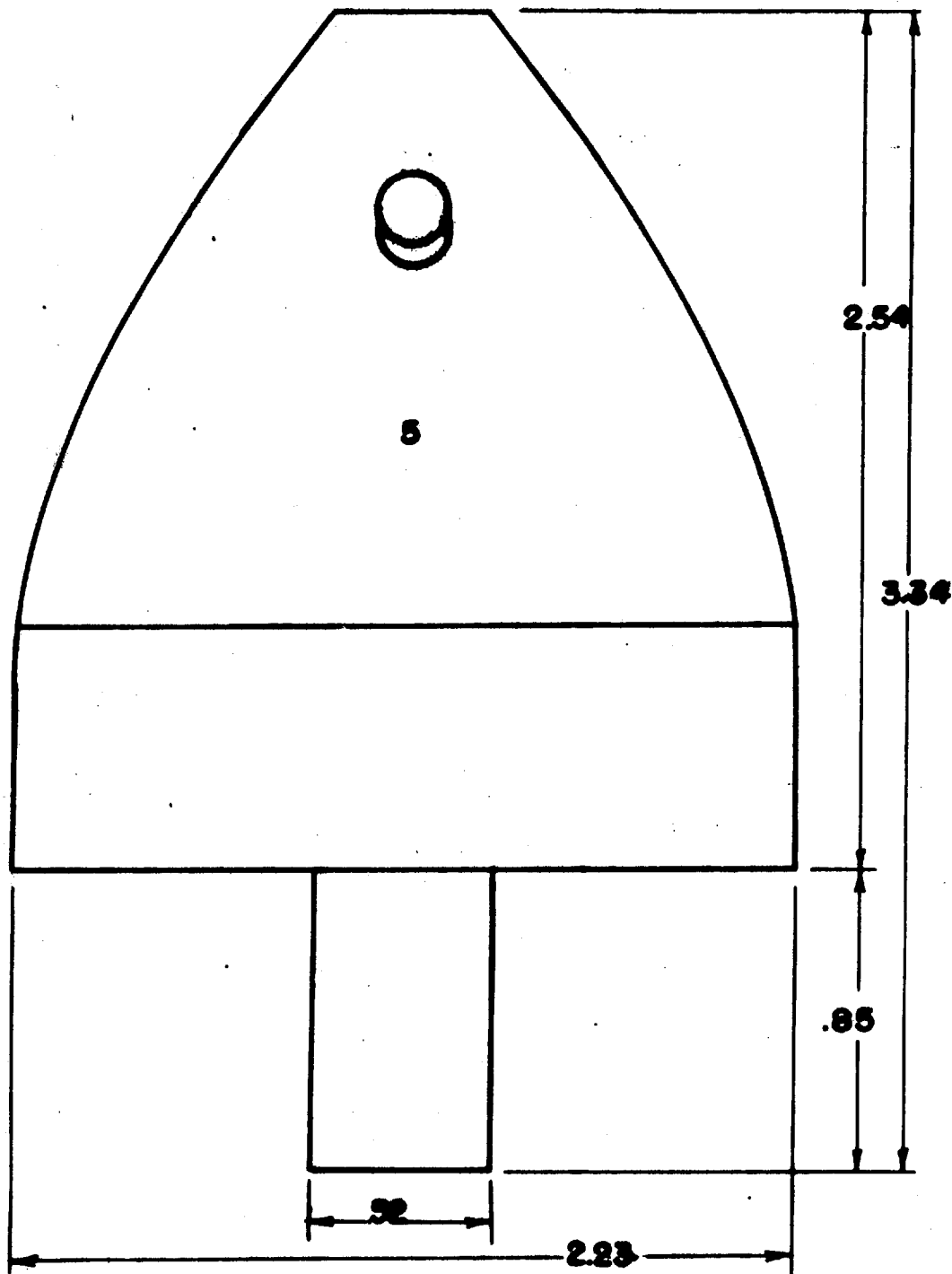

CHICOM POINT INITIATING BASE DETONATING IMPACT FUZE TYPE UNKNOWN

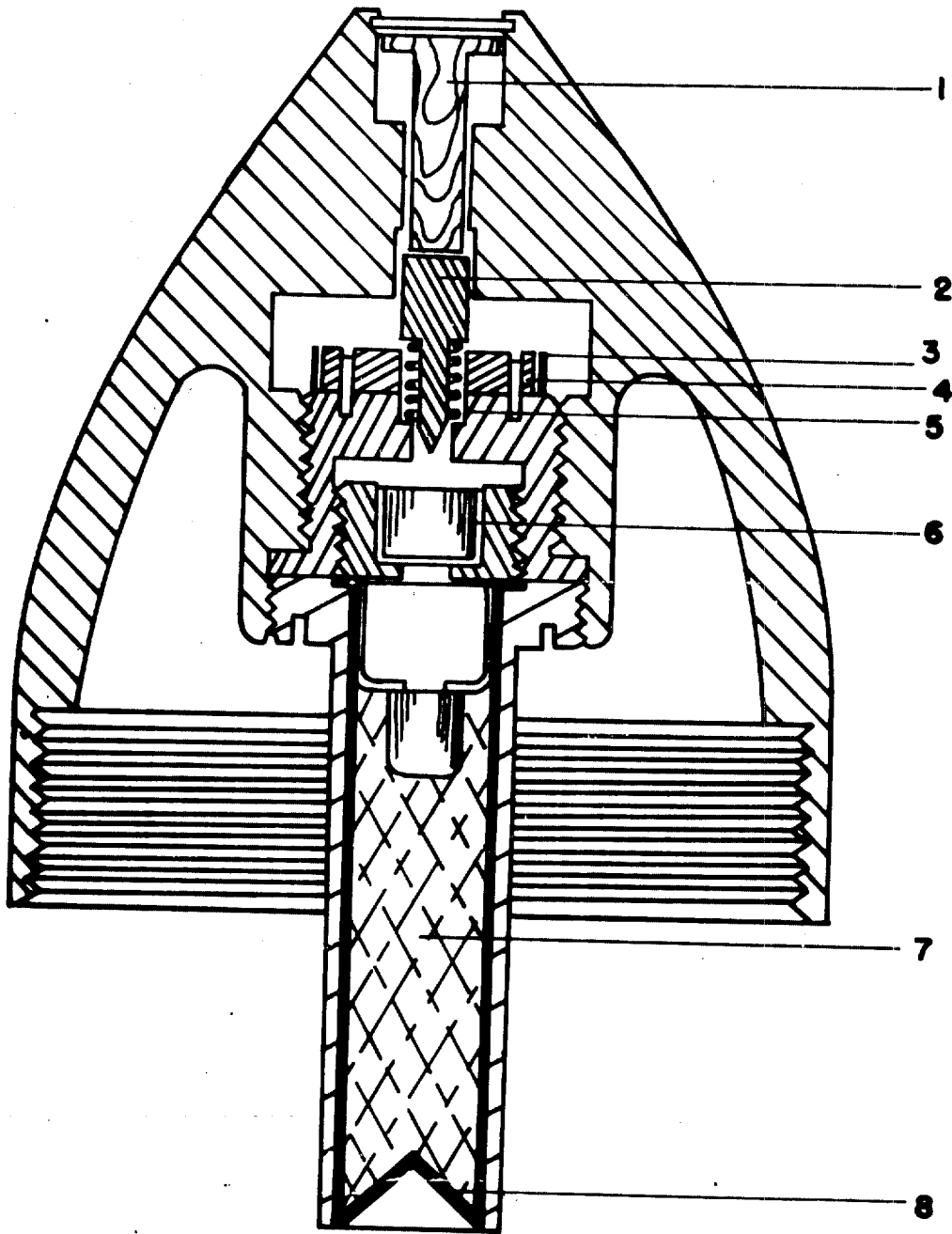

4-3/4-4

## CHICOM POINT DETONATING IMPACT FUZE TYPE 1 (ROCKET)

a. General. The ChiCom Type 1 (Rocket) fuze is a modified version of the Soviet V-25 rocket fuze and is employed interchangeably with the V-25 on the Soviet 140-mm rocket ML40F. It is a selectable superquick or delay impact fuze that arms entirely by centrifugal force. The Type 1 is very robust. Each opening is sealed with a plastic ring so that the fuze is completely waterproof. The fuze is cadmium plated internally and certain moveable parts such as detents, are chromeplated. All setback detents seen in the Soviet V-25 have been eliminated in the ChiCom Type 1 and an additional centrifugal element has been added. This additional component increases the length of the Type 1 over that of the Soviet V-25. The Type 1 has only one delay setting of 0.025 seconds. The Soviet V-25 has two selectable delays of 0.025 and 0.1 seconds. In all other ways the fuzes are identical. The centrifugal safety device added to the Type 1 consists of a flat, circular housing machined from steel. All parts are chrome plated against corrosion and to reduce friction. The housing has a central flash channel that aligns with the upper detonator and the flash channel in the fuze body. Two lateral grooves act as a track for a "U" shaped, sliding detent. This detent is rectangular in shape with a notch in each leg as a recess for a spring loaded detent to lock. The detents are located in cavities drilled through the housing. A thin cup is pressed over the machined housing to secure all components within the housing.

### b. Characteristics.

Action ----- Selective instantaneous or delay

Loaded weight ----- 694 grams (1.53 lbs)

Body material ----- Steel

c. Functioning. Upon firing, setback causes the firing pin (2) to seat firmly upon the centrifugal detents (4) locking them in place. The detent locking cup (6) is also setback compressing its spring. As acceleration ceases and centrifugal forces increase, the centrifugal detents (4) under the firing pin (2) move outward against their springs (5). The detent blocking cup spring forces the detent blocking cup (6) upward until it rests against the shoulder of the firing pin. In this position it blocks any return of the detents (4). Simultaneously, centrifugal force causes the sliding detent to move outward along its track opening the flash channel. The fuze is now armed. With the selector set on superquick, the flash channel is open from the upper detonator (8) to the lower detonator (14) in the booster cup. Upon impact, the firing pin is driven into the upper detonator (8) or upon impact at flat angles, the graze weights (10) move laterally and cam the detonator carrier (9) upward so that the detonator (8) is impaled on the firing pin (2). The detonator flashes down into the lower detonator (14) which initiates the booster.

CHICOM POINT DETONATING IMPACT FUZE TYPE 1 (ROCKET)

If the selector (13) is set on delay, the delay elements (20) are ignited upon functioning of the upper detonator (8). However, the selector blocks the flash channel on the delay setting so that the flash from the upper detonator cannot reach the lower detonator (14). When the delays (20) burn through after approximately 0.025 seconds, they flash into the lower detonator (14) causing the booster to detonate.

d. Weapons and projectiles with which used.

Weapons

Projectiles

107-mm: rocket launcher Type ?

107-mm HE-Frag ----- Type H-12

CHICOM POINT DETONATING  
IMPACT FUZE TYPE 1 (ROCKET)

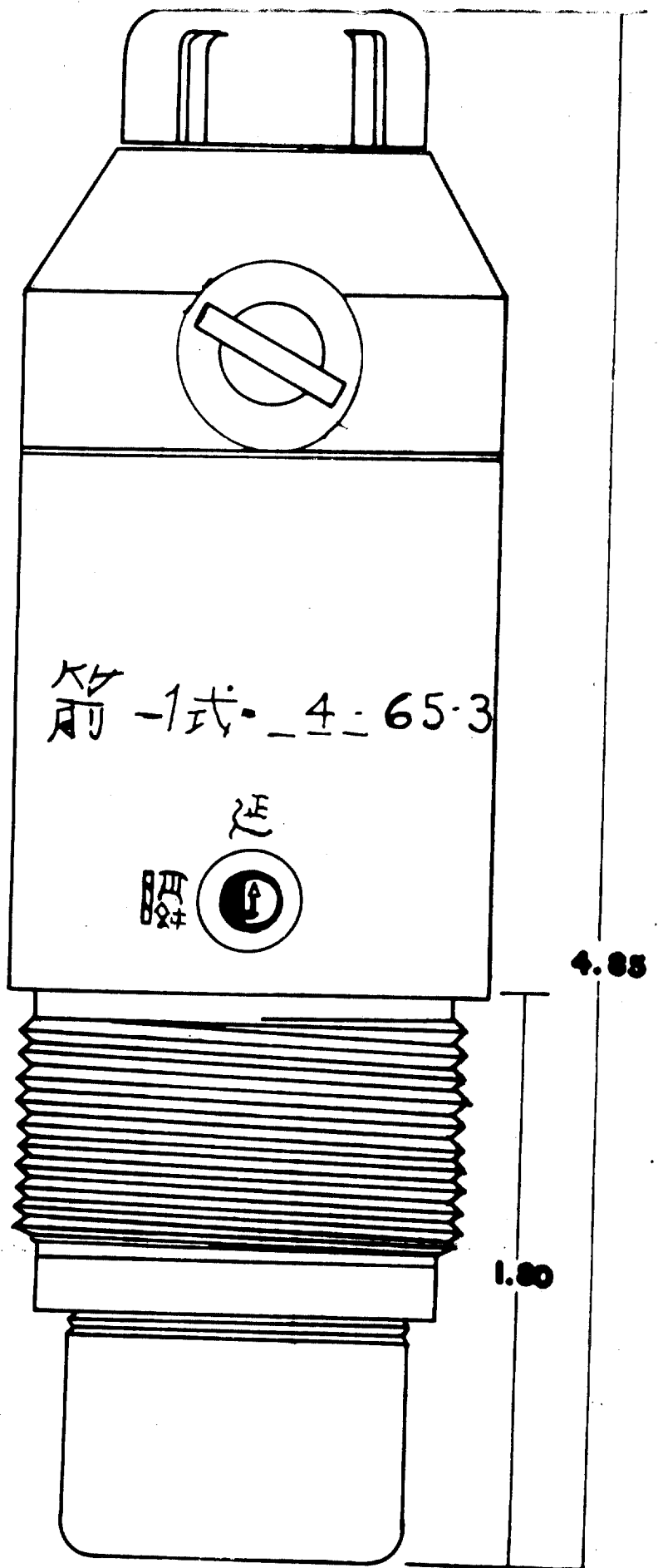

CHICOM POINT DETONATING  
IMPACT FUZE TYPE 1 (ROCKET)

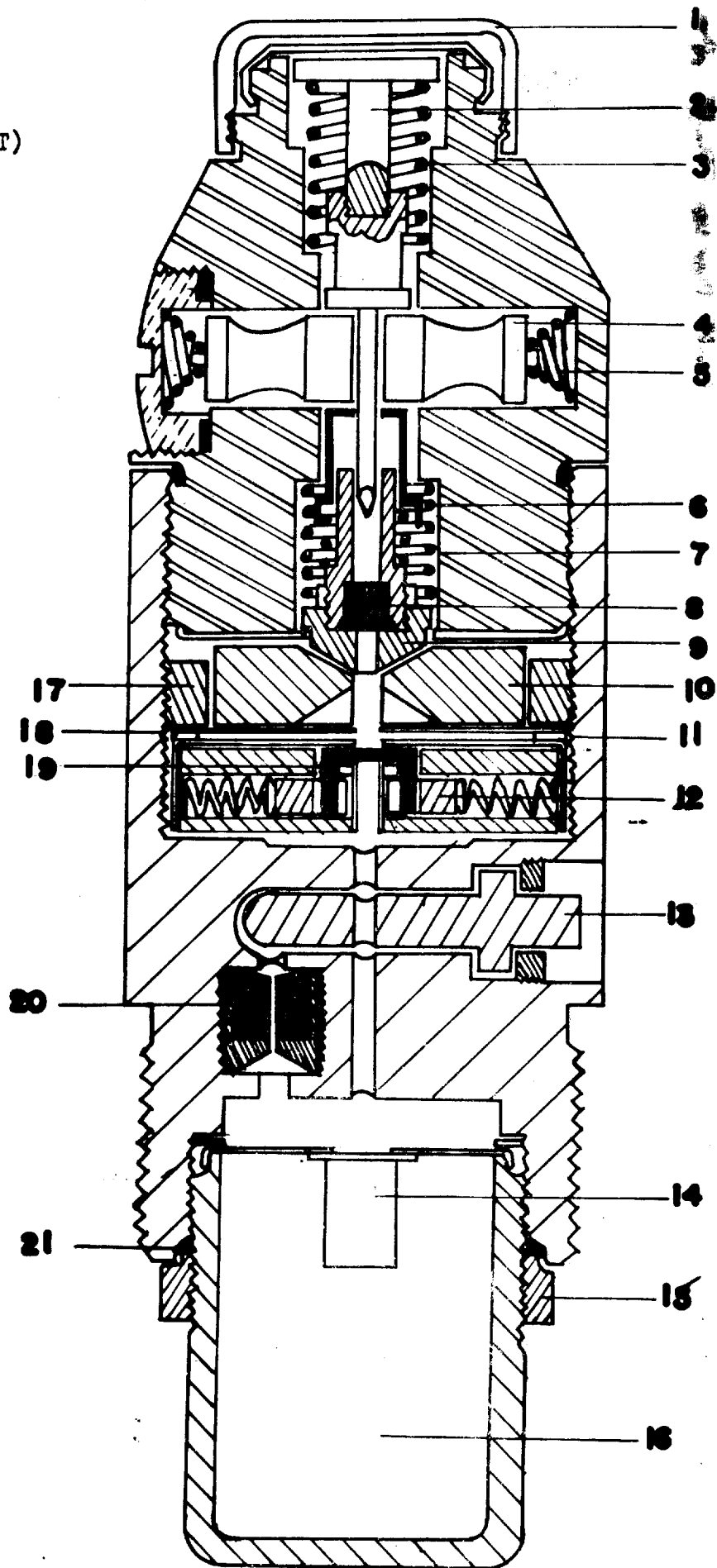

CHICOM POINT DETONATING IMPACT FUZE TYPE 1 (RECOILLESS RIFLE)

a. General. The ChiCom Type 1 recoilless rifle fuze is another exact copy of the Soviet GK-2. The relationship between the Type TS-2 is not understood. The Type TS-2 examined was manufactured earlier than the Type 1. Both were produced by plant 34 and appear to be identical. The booster cup is sealed with nylon pipe sealant and the entire fuze appears waterproof. Workmanship appears to be excellent.

b. Characteristics.

Action ----- Instantaneous

Loaded weight ----- 176 grams (0.38 lbs)

Body material ----- Aluminum

c. Functioning. For a discription of the functioning of the Type 1, refer to the Soviet GK-2.

d. Weapons and projectiles with which used.

Weapons

75-mm: recoilless rifle Type 52

Projectiles

75-mm RR Fin-Stabilized HEAT

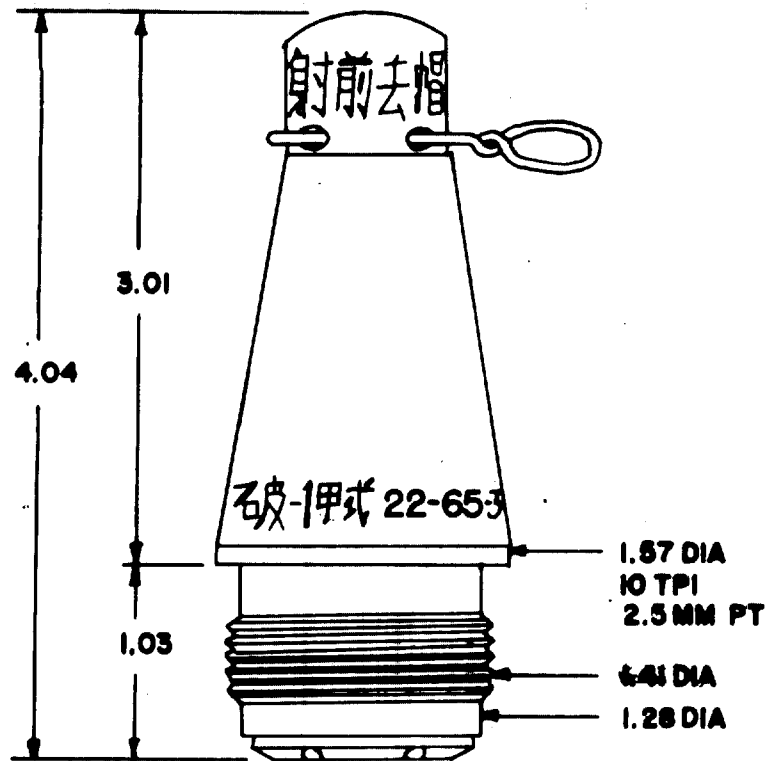

4-9 / 4-10

## CHICOM POINT DETONATING IMPACT FUZE TYPE 1 (ARTILLERY)

a. General. The ChiCom Type 1 is a setback and centrifugal force armed fuze, with pyrotechnic delay arming and a graze sensitive feature. Its most notable feature is its cocked detonator. Overall color is black and the markings are stamped into the upper fuze body. The Type 1 is very robust, but the design does not display the current trend toward extreme waterproofness noted in other ChiCom/Soviet fuzes. The Type 1 is indiganeous to Communist China and is not a copy of any known fuze.

The TYPE 1 has an upper and lower fuze body that are threaded together. The upper body is then roll crimped with the lower body. The cap at the nose of the fuze is normally removed for instantaneous action or left on for nondelay, graze sensitive action. A thin metal membrane covers the firing pin opening in the fuze and is securely crimped to an annular groove. The firing pin head (1) is a separate flanged metal disc that fits over the firing pin shank (2). The firing pin is of two piece construction. The firing pin is not restrained by an anti-creep spring. The firing pin is locked in the unarmed position by two centrifugal detents. One detent (7) is a direct arming type that is spring loaded inward by the detent spring (6). The detent and spring are retained in the cavity by the detent plug (5). The opposite detent is of the delay arming type. Its housing (18) contains a solid, consumable, black powder pellet (19) that is ignited by the setback primer (29). As the pellet is consumed, centrifugal force causes the detent to retract into the evacuated cavity, unlocking the firing pin (20). A detent locking sleeve (8) is forced forward by its spring to lock the two centrifugal detents in the armed position. In the unarmed position the locking sleeve (8) is held downward by the two extended detents.

The graze sensitive firing assembly (21) is held locked in the unarmed position by the two centrifugal detents. When the two detents move out and are locked by the locking sleeve (8), the firing assembly is then held in position by the anti-creep spring (17). The graze firing assembly has three locking ball recesses that house the three locking balls (10) that lock the primer carrier (22) in the cocked position. An annular groove, cut into the inner wall of the lower fuze body, is located just above the locking ball recesses. When the graze firing assembly (21) moves forward, by impact inertia, the locking balls (10) are forced into the groove and release the cocked primer carrier (22). The primer carrier (22) is spring loaded upward by the compressed primer carrier spring (11). The spring (11) propells the primer carrier forward on graze impacts so that the primer (9) is impaled upon the firing pin (20). The primer carrier spring (11) is retained in the primer carrier by the thread plug (12) that is perforated by a single flash channel. The graze firing mechanism (21) is prevented from rotating by a locking ball (23) positioned in a recess that is cut into both the fuze body and the graze firing mechanism housing. The entire assembly is closed by a threaded plug (13). This plug possesses two spanner holes and a central flash channel leading to the detonator (15). The detonator rests on a shaped detonator holder (14), which in turn is separated from the booster explosive (16) by cardboard discs (24). The booster is sealed to the fuze

# CHICOM POINT DETONATING IMPACT FUZE TYPE 1 (ARTILLERY)

body by an epoxy sealing compound.

A vertical cavity in the upper fuze body houses the setback primer (29) and firing pin assembly (27). The primer is fixed in the bottom of the cavity. The firing pin is moveable and is separated from the primer by the setback spring (28). The firing pin has two vertical grooves cut into its surface that act as flash channels. The firing pin (27), and primer (29), are retained in the cavity by a slotted plug (25). A horizontal flash channel (30) connects the primer cavity with the consumable black powder pellet (19) in the delay arming detent assembly. The flash channel (30) permits flames from the primer (29) to be transmitted to the delay arming pellet (19). Dud Type 1 and Type 3 fuzes are considered hazardous due to the armed, cocked primer assembly.

## b. Characteristics.

Action ----- Instantaneous  
Loaded weight ----- 405 grams (0.87 lbs.)  
Body material ----- Steel

c. Functioning. Prior to firing, the fuze cap may be removed for instantaneous action or left on for non-delay action. Upon firing, the detent locking collar (8) moves down compressing its spring, removing frictional resistance from the centrifugal detents. Simultaneously, the set-back firing pin (27) moves downward against the spring (28), firing the primer (29). The resulting flame passes through the flash channels (26) in the firing pin (27) and passes through the channel (30) igniting the delay arming pellet (19). Centrifugal force causes the detent (7) to move outward against its spring (6), partly unlocking the firing pin (20). As the pellet (19) is consumed, centrifugal force causes the delay arming detent to move into the evacuated cavity. This produces delay arming of the firing pin (20) and the graze firing assembly (21). As acceleration diminishes, the locking collar spring forces the collar (8) forward, preventing the centrifugal detents from extending upon spin decay. The fuze is now armed. In flight, the anti-creep spring prevents the graze firing assembly (21) from moving forward prematurely, firing the fuze. Upon impact, the firing pin (20) is driven downward into the primer (9) which flashes through the channel into the detonator (15) initiating the booster (16). On graze impacts, inertia causes the graze firing mechanism (21) to move forward until the locking balls (10) are forced out of their recesses into the annular groove. The compressed primer carrier spring (11) propels the primer carrier (22) forward, impaling the primer (9) on the sharp pointed firing pin (20), initiating functioning. Dud Type 1 and Type 3 fuzes are rare due to the combined impact and graze action functioning.

CHICOM POINT DETONATING IMPACT FUZE TYPE 1 (ARTILLERY)

d. Weapons and projectiles with which used.

Weapons

75-mm: recoilless rifle type 52

Projectiles

75-mm RR HE-Frag ----- Type ?

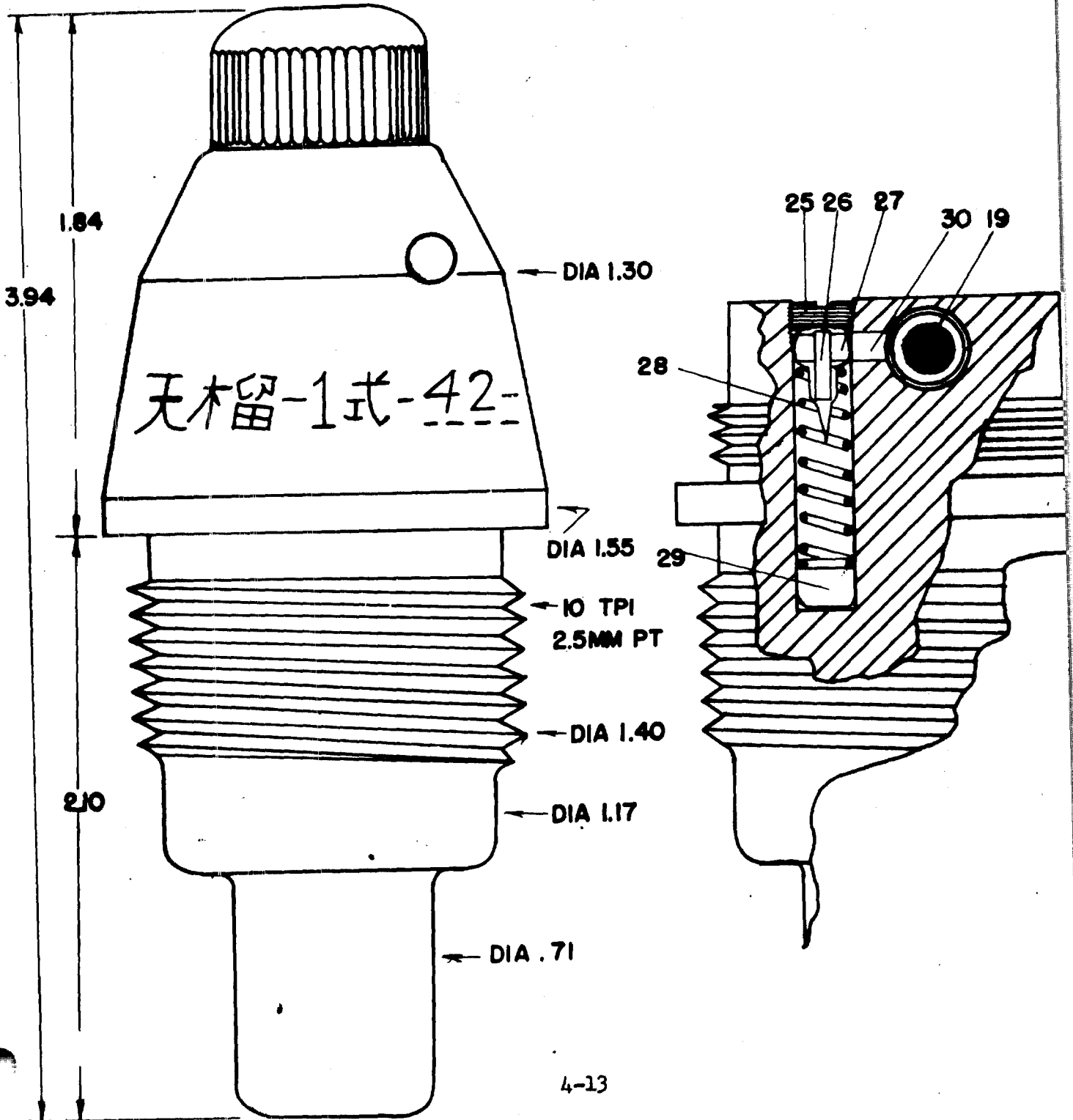

CHICOM POINT DETONATING IMPACT FUZE TYPE 1 (ARTILLERY)

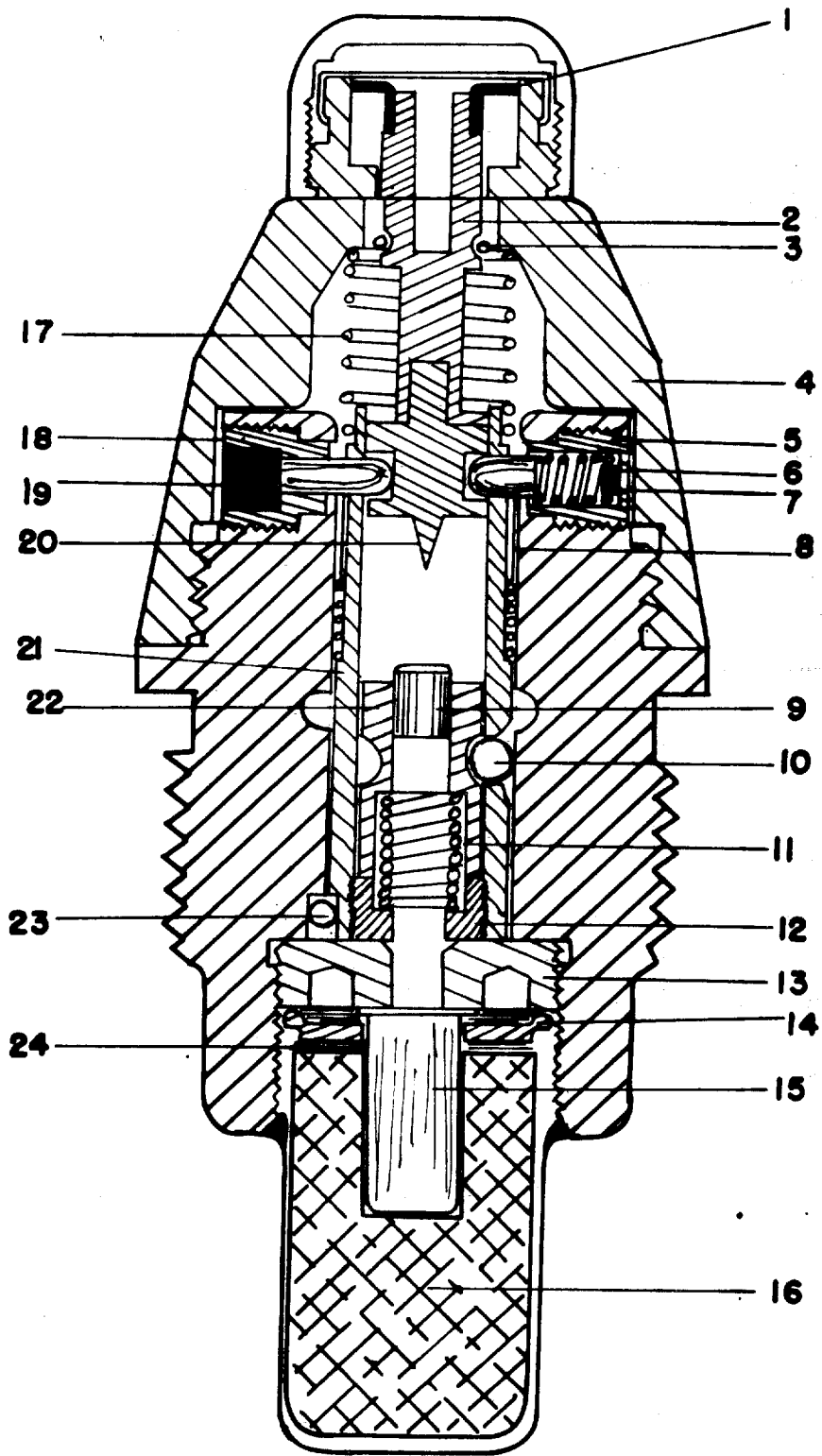

CHICOM POINT DETONATING IMPACT FUZE TYPE 1 (ARTILLERY)

a. General. The ChiCom Type 1 (Artillery) fuze is an exact copy of the Soviet KTM-1. The upper portion of the fuze body is cadmium plated while the lower fuze body is blued. The entire fuze is sprayed with varnish as a corrosion resistant. The Type 1 (Artillery) is entirely waterproof. This is in keeping with current ChiCom and Soviet fuze design philosophy.

b. Characteristics.

Action ----- Instantaneous  
Loaded weight ----- 365 grams (0.80 lbs.)  
Body material ----- Steel

c. Functioning. For detailed functioning of the ChiCom Type 1 (Artillery) see the entry for the Soviet KTM-1.

d. Weapons and projectiles with which used.

Weapons	Projectiles
57-mm: AT Gun Type 55	57-mm HE-Frag ----- Type 271
76-mm: Field Gun Type 54	76-mm HE-Frag ----- Type 354
85-mm: Field Gun Type 7	85-mm HE-Frag ----- Type 367
100-mm: Field Gun Type ?	100-mm HE-Frag ----- Type 412

CHICOM POINT DETONATING IMPACT FUZE TYPE 1 (ARTILLERY)

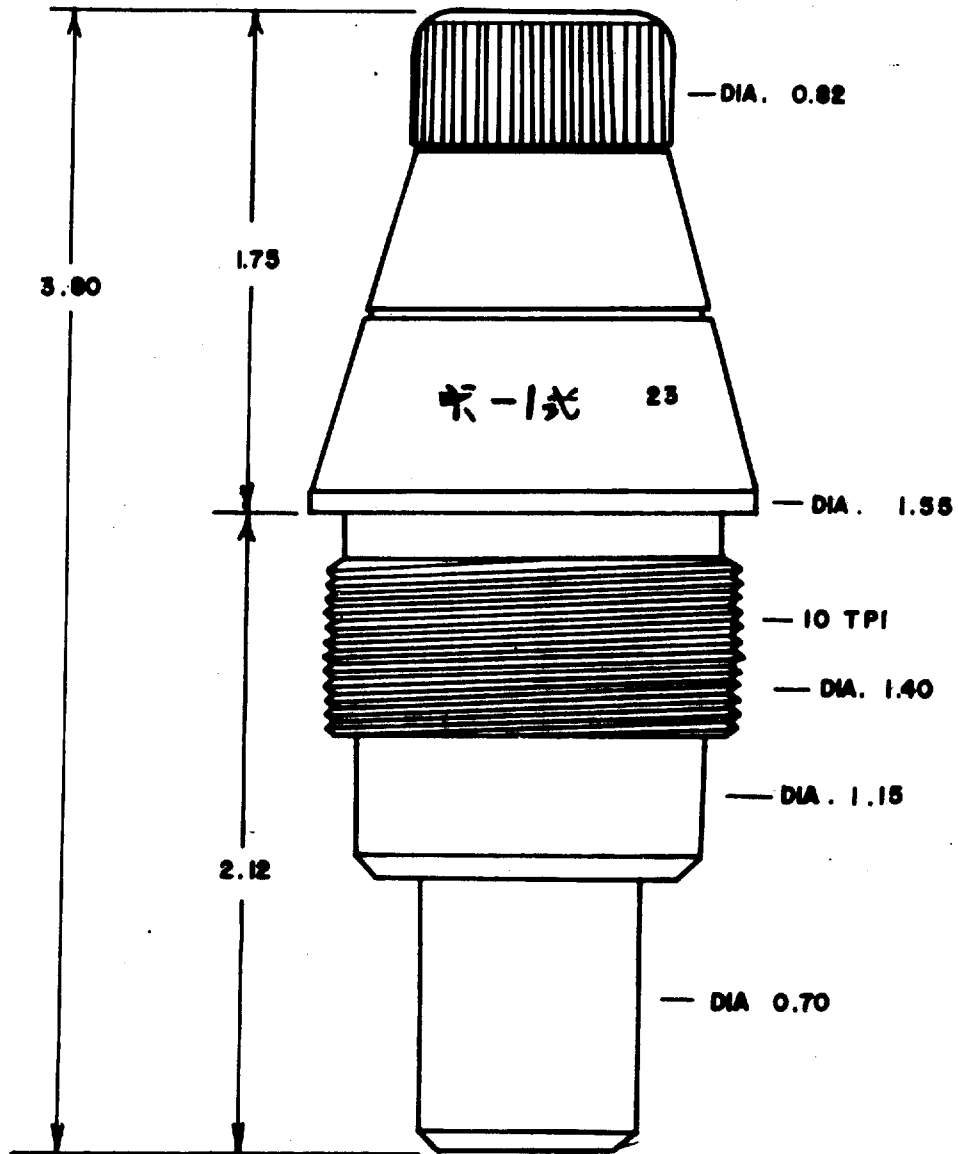

CHICOM POINT DETONATING IMPACT FUZE TYPE TS-2

a. General. The ChiCom Type TS-2 is an exact copy of the Soviet GK-2 fuze. The only major departure from normal ChiCom practices is the fuze designation. The TS-2 is the first ChiCom fuze encountered with an alphabetical designation and may signal the arrival of a new nomenclature system. Like its Soviet counterpart, the TS-2 is employed on fin stabilized recoilless rifle ammunition.

b. Characteristics.

Action ----- Instantaneous

Loaded weight ----- 180 gm. (0.39 lb.)

Body material ----- aluminum

c. Functioning. The operation of the ChiCom Type TS-2 is identical to that of the Soviet GK-2 fuze.

d. Weapons and projectiles with which used.

Weapons

Projectiles

75-mm: Recoilless Rifle Type 52

75-mm Fin Stabilized HEAT ---- ?

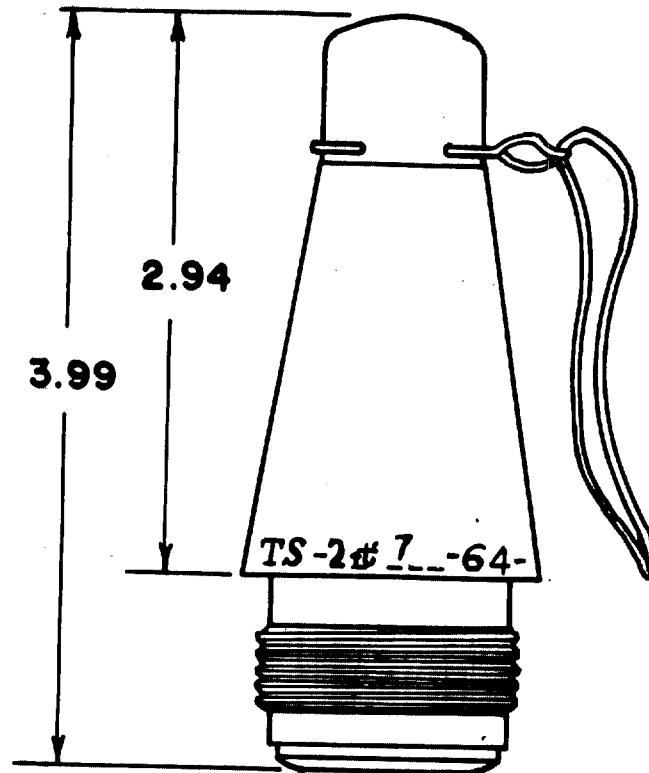

4-17/4-18

CHICOM POINT DETONATING IMPACT FUZE TYPE 3 (SPECIAL)

a. General. The ChiCom Type 3 (Special) is identical in every detail with the Type 1, except for color and markings. Parts are interchangeable between fuzes and it is apparent the same drawings were used for both fuzes. The reason for the different nomenclature on identical fuzes is unknown. The fuzes have been employed interchangeably. The ChiCom Type 3 (Special) fuze has a black lower fuze body. The upper fuze body is cadmium plated and presents a slightly yellow appearance. The ChiCom Type 1 fuze is black overall.

b. Characteristics.

Action ----- Instantaneous

Loaded weight ----- 405 grams (0.87 lb.)

Body material ----- Steel

c. Functioning. Information on the functioning of the Type 3 (Special) can be found in the entry under the ChiCom Type 1 fuze.

d. Weapons and projectiles with which used.

Weapons

Projectiles

75-mm: ChiCom Recoilless Rifle,  
Type 52

75-mm HE-Frag ----- T28

CHICOM POINT DETONATING IMPACT FUZE TYPE 3 (SPECIAL)

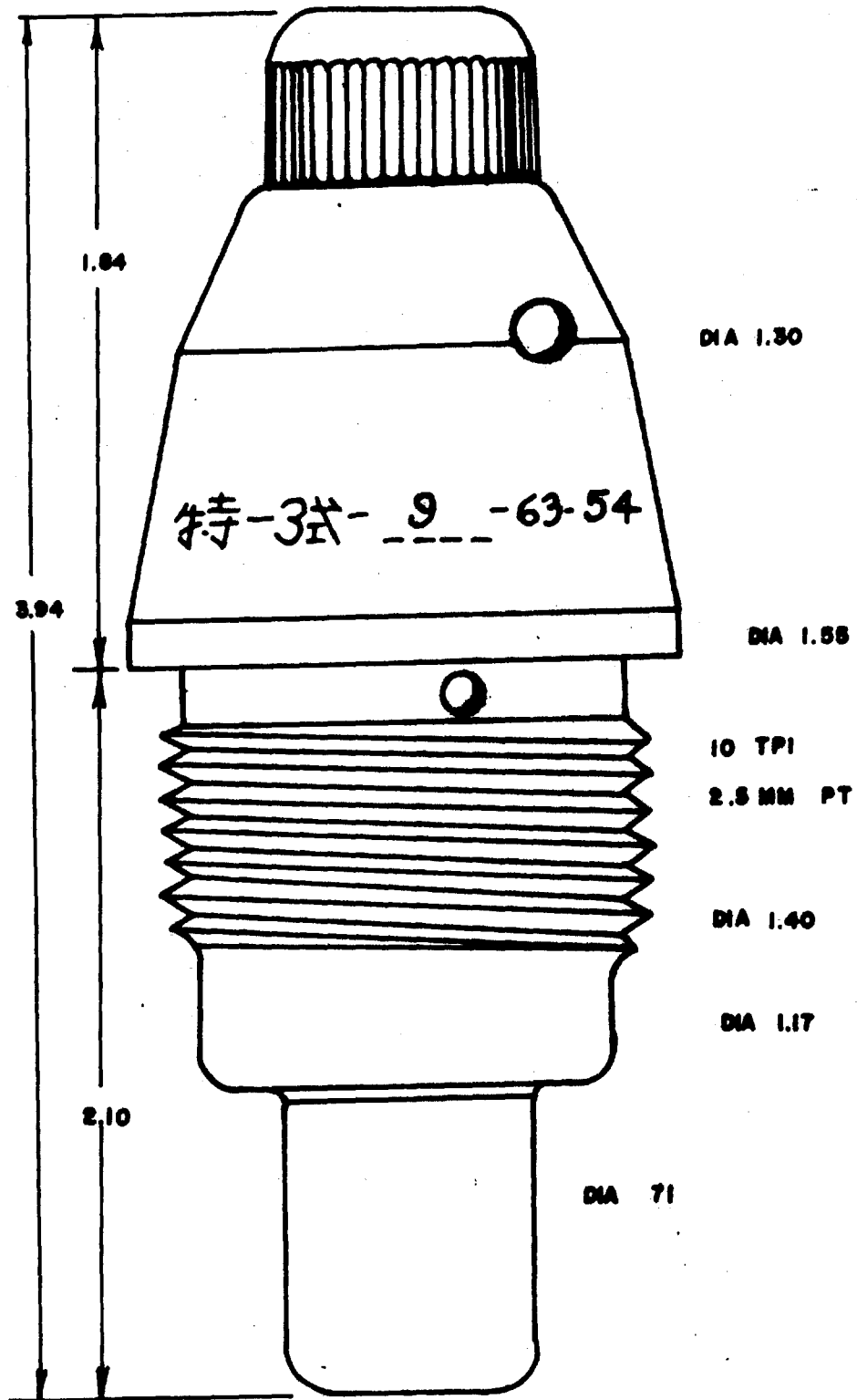

CHICOM POINT DETONATING IMPACT FUZE TYPE 5

a. General. The ChiCom Type 5 point detonating impact fuze is an exact copy of the Soviet M-5 fuze. Some fuzes have been "sanitized", i.e., factory markings and fuze nomenclature have been machined off the fuze body. Further information about this fuze can be found in the entry for the Soviet M-5 fuze.

b. Characteristics.

Action ----- Instantaneous

Loaded weight ----- 77 grams (0.16 lbs.)

Body material ----- Plastic

c. Functioning. Detailed functioning for this fuze can be found in the entry for the Soviet M-5 fuze.

d. Weapons and projectiles with which used.

60-mm: ChiCom Type 31 and Type 63 mortars

60-mm HE-Frag ----- Type 7

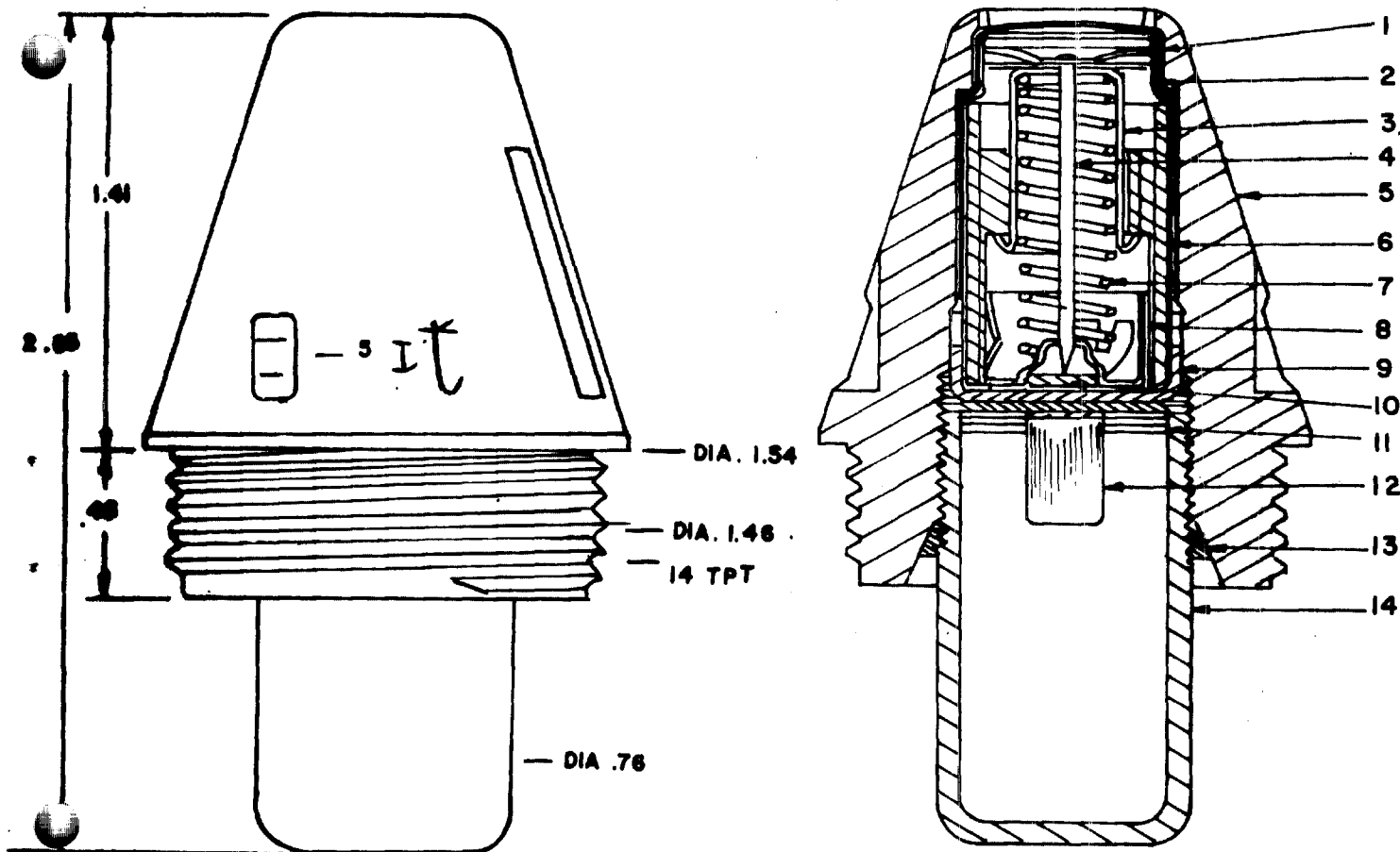

CHICOM POINT DETONATING IMPACT FUZE TYPE 6

a. General. The ChiCom Type 6 fuze is an exact copy of the Soviet M-6 mortar fuze, using the same body and internal components. A detailed description of the ChiCom Type 6 is needless due to the similarities between it and the Soviet M-6.

b. Characteristics.

Action ----- Superquick

Loaded weight ----- 127.1 gm. (0.28 lb)

Body material ----- plastic

c. Functioning. The operation of the ChiCom Type 6 is identical to that of the Soviet M-6 mortar fuze.

d. Weapons and projectiles with which used.

Weapons

82-mm: ChiCom Type 53

Projectiles

82-mm HE ----- Type 53; M-30

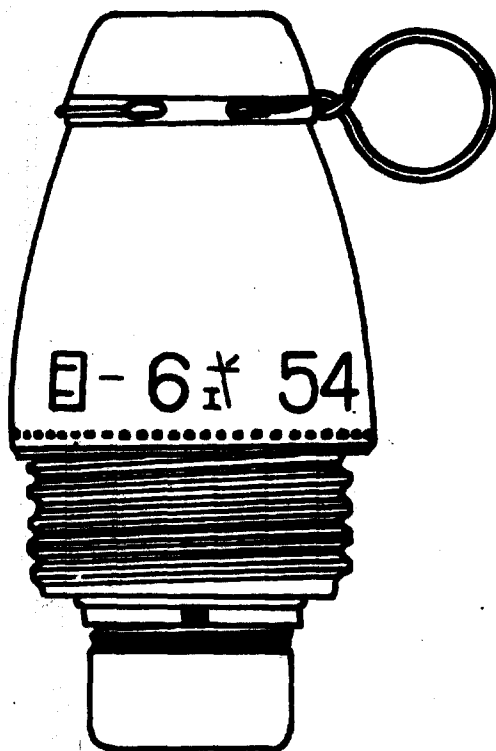

CHICOM POINT DETONATING IMPACT FUZE TYPE 7 (ARTILLERY)

a. General. The ChiCom Type 7 (Artillery) fuze is an identical copy of the Soviet GVMZ-7 fuze. It is employed in the same 120-mm mortar applications. The Type 7 (Artillery) appears to be obsolescent and is being replaced by the ChiCom Type 12 fuzes in all 120-mm mortar applications. See the entry under the Soviet GVMZ-7 for more detailed information.

b. Characteristics.

Action ----- Instantaneous or delay  
 Loaded weight ----- 460 grams (1.01 lbs.)  
 Body material ----- Steel

c. Functioning. See the entry under the Soviet GVMZ-7 for detailed functioning of this fuze.

d. Weapons and projectiles with which used.

Weapons

120-mm: ChiCom Type 53 mortar

Projectiles

120-mm HE-Frag ----- Type ?

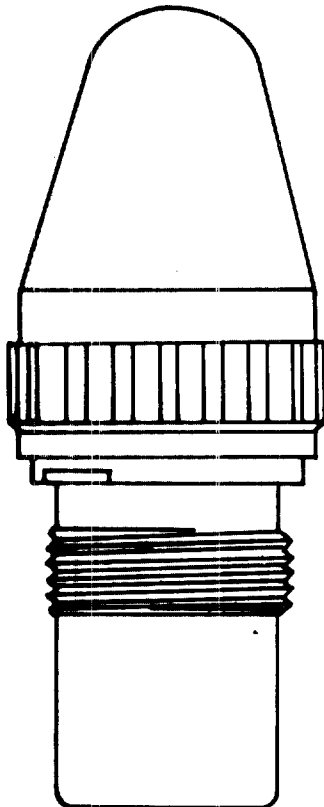

WITH SHIPPING CAP

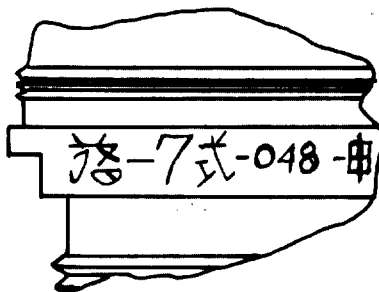

4-23/4-24

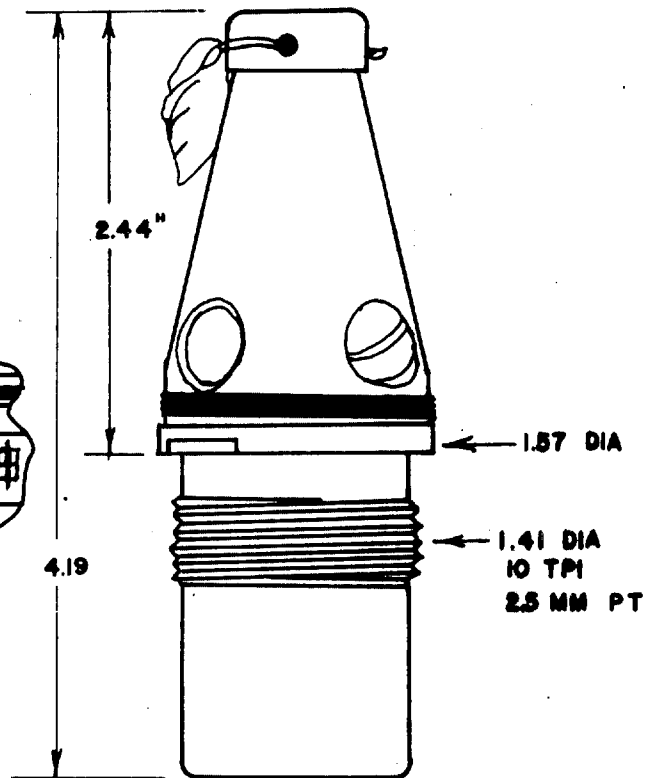

WITHOUT SHIPPING CAP

CHICOM POINT DETONATING IMPACT FUZE TYPE 7 (MORTAR)

a. General. The ChiCom Point Detonating Impact Fuze Type 7 (Mortar) consists of a brass body, firing pin assembly, primer assembly, and a detonator assembly. It is a setback armed, bore safe fuze. The firing pin assembly consists of a firing pin (4), an arming sleeve (2), an arming sleeve retaining ball (1), two firing pin locking balls (5), an arming sleeve spring (3) and a firing pin guide. The Type 7 fuze is considered an improved version of the Soviet M-50. The head of the firing pin is raised above the head of the fuze body producing superquick functioning rather than non-delay as in the case of the M-50. The Type 7 has a clear cellulose cover glued over the nose of the fuze, partially waterproofing this end of the fuze. The Type 7 is considered obsolete, having been replaced almost completely by the ChiCom Type 100-3 fuze.

b. Characteristics.

Action ----- Instantaneous  
Loaded weight ----- 156 grams (0.34 lbs.)  
Body material ----- Brass

c. Functioning. Once the fuze is assembled to the round no further preparation is necessary before firing. Upon firing, setback causes the arming sleeve (2) to move rearward compressing its spring (3). This releases the arming sleeve retaining ball (1) which falls down into the fuze body. When setback diminishes, the arming sleeve spring (3) forces the arming sleeve (2) forward into the place formerly occupied by the arming sleeve retaining ball. This uncovers the two firing pin locking balls (5) which escape from their cavities into the fuze body, completely unlocking the firing pin (4). Upon impact, the firing pin is driven into the primer (7) which in turn initiates the gain (8).

d. Weapons and projectiles with which used.

Weapons	Projectiles
60-mm;: ChiCom Type 31 and Type 63	60-mm HE-Frag ----- Type 7

CHICOM POINT DETONATING IMPACT FUZE TYPE 7 (MORTAR)

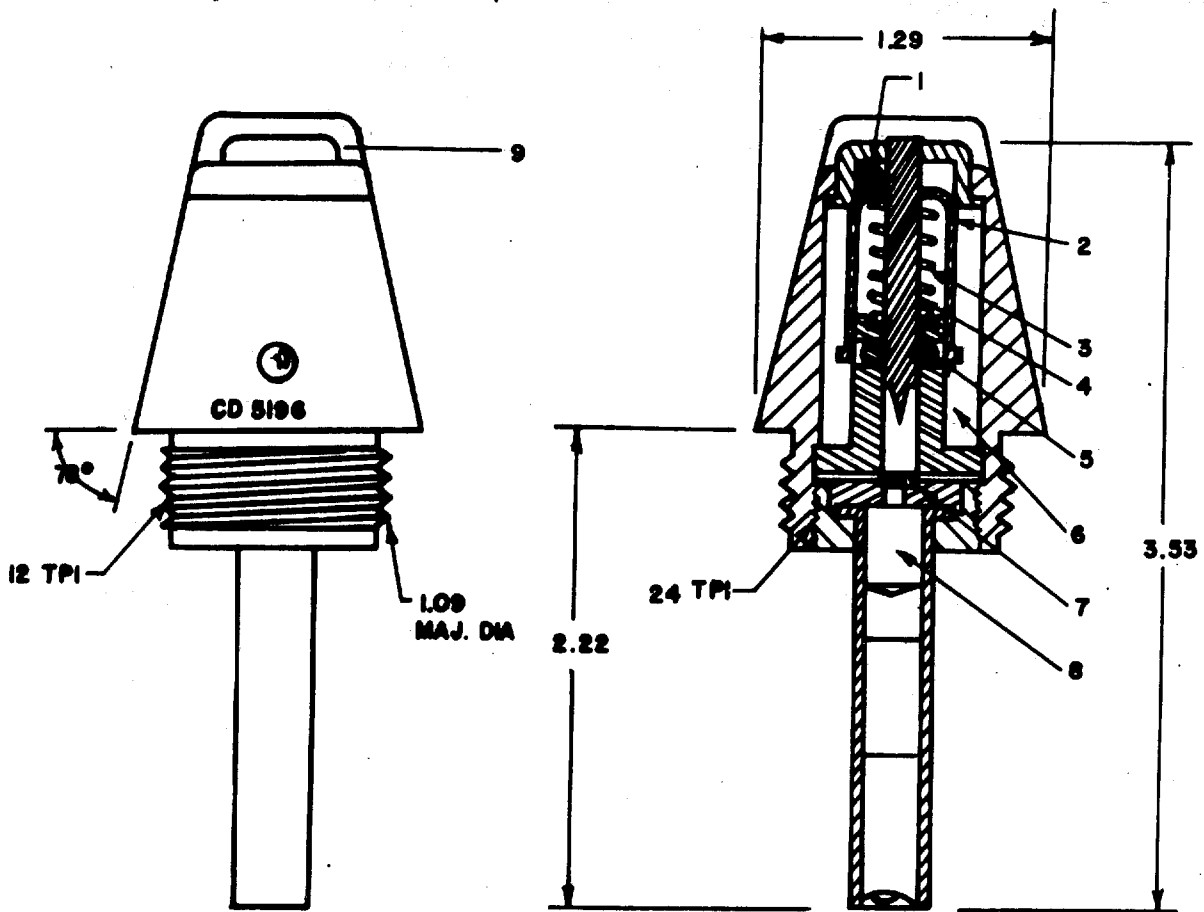

CHICOM POINT DETONATING IMPACT FUZE TYPE 8

a. General. The ChiCom Type 8 fuze was first encountered during the Korean War. It has largely been superseded by more modern fuzes, but is still periodically encountered. The Type 8 fuze is constructed of brass and is easily identified by its configuration. It is straight point detonating, setback armed and is currently employed only in the cast iron 60-mm mortar shell.

b. Characteristics.

Action ----- Instantaneous  
Loaded weight ----- 167 grams (0.36 lbs)  
Body material ----- Brass

c. Functioning. When the round is fired, setback causes the setback sleeve (6) to move to the rear, striking the beveled set-back locking ring (10) with sufficient force to adhere by tension and remain secured in the rearward position. The primer carrier locking ball (7) falls out of its recess in the primer carrier (8). The primer carrier is now free to creep forward. As the angle of fall of the round increases, the primer carrier (8) moves forward to the front of the primer carrier housing (5) until it comes to the primer carrier stop collar.(4). At this point the two primer safety balls (14) are out into the recess in the end of the primer carrier housing (5) by the tip of the striker. Upon impact, the two primer safety balls (14) in the primer carrier housing (5) securely lock the primer carrier (8) in the forward position so that the firing pin (1) can produce a full blow on the primer (9), which in turn functions the detonator (13). At short ranges, or low angles of fire, the primer carrier (8) is carried forward upon impact by inertia to impale itself on the firing pin (1) and thereby function the detonator.

d. Weapons and projectiles with which used.

Weapons	Projectiles
60-mm: ChiCom Type 31 & Type 63	60-mm HE-Frag ----- Type ?

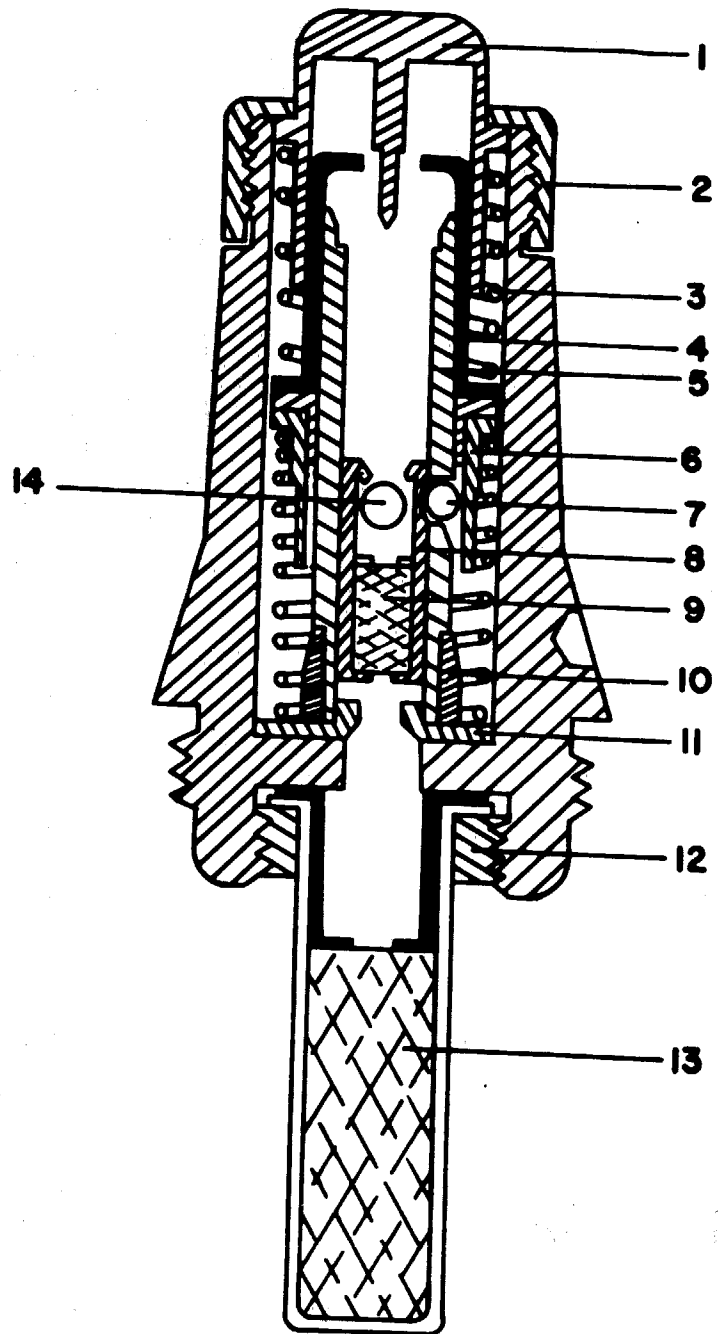
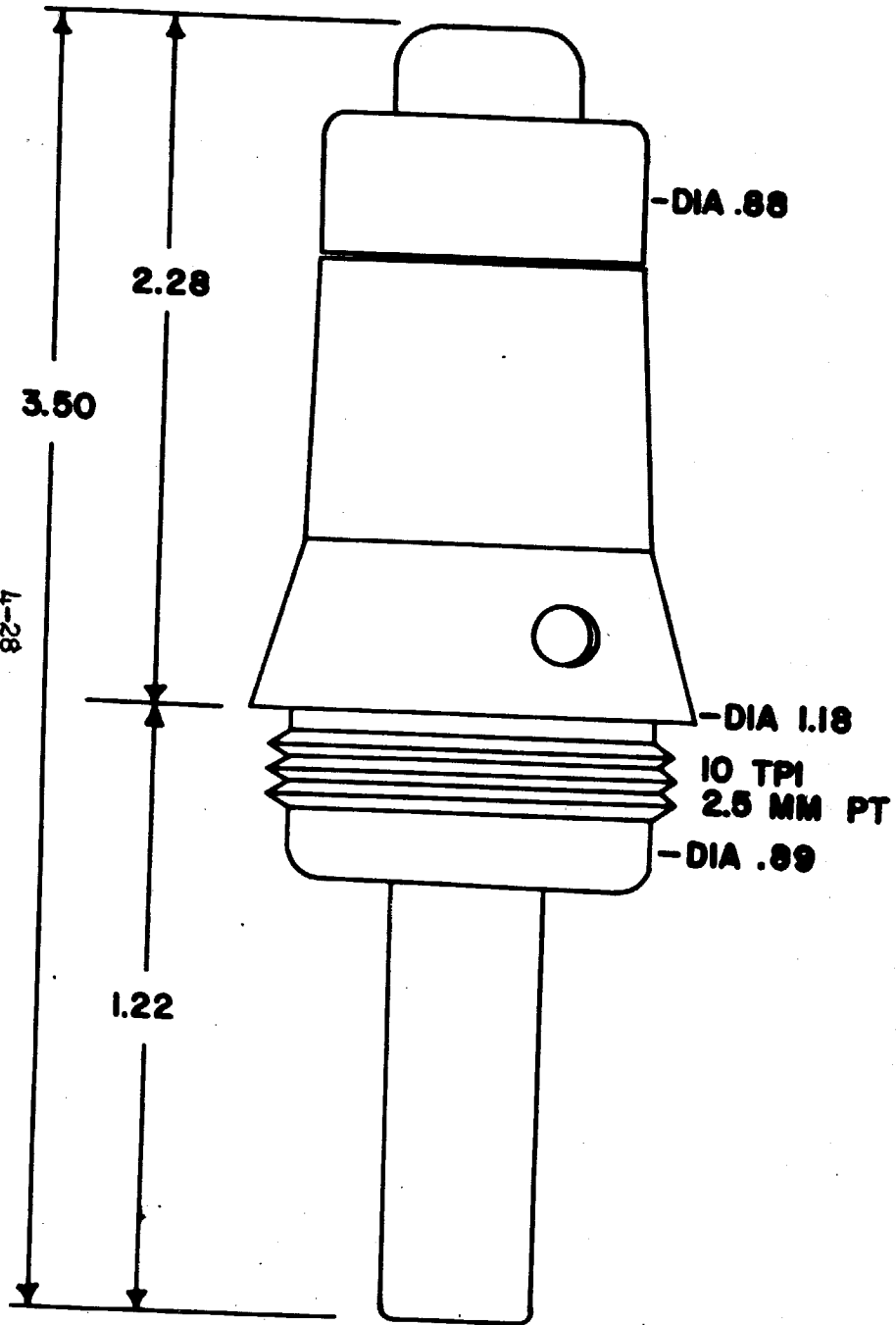

CHICOM POINT DETONATING IMPACT FUZE TYPE 8

## CHICOM POINT DETONATING IMPACT FUZE TYPE 9

a. General. The ChiCom Type 9 point detonating fuze is setback armed and functions non-delay. It has been employed in the 60-mm, 82-mm, and 120-mm mortars, but is currently considered obsolete in the ChiCom inventory. The Type 9 is identified by the markings stamped on the ogive; however, in most cases there are no markings at all. The Type 9 is identical internally to the Type 10 fuze which has been employed on the ChiCom 120-mm mortar projectile. The Type 9 has a brass body, threaded at the nose to receive a fixed firing pin nose plug. Internally, a cylindrical arming sleeve (3) rests on top of the arming clip (5). The arming clip is a "U" shaped brass clip with the ends of its legs curving outward. The arming clip (5) fits over the end of the primer holder (7). The arming sleeve (3) is prevented from moving downward, removing its solid mass from between the primer and the firing pin, by the outward bent legs of the arming clip (5). The primer (6) is secured in the primer holder by a threaded plug. The detonator-booster is composed of a copper tube containing the initiating charge in an inverted clip and the base charge. The booster is closed by a copper cup perforated by a single hole. The booster is assembled to the fuze body by an externally threaded brass plug with spanner wrench slots.

### b. Characteristics.

Action ----- non-delay  
Loaded weight ----- 172 grams (0.38 lbs.)  
Body material ----- brass

c. Functioning. The safety wire (4) is removed prior to the fuze being screwed into the projectile. The fuze cannot be assembled to the round until the safety wire (4) is removed. Thus, there are no dud rounds because of the safety wire being left in the fuze. Upon firing, setback causes the arming sleeve (3) to move rearward slipping over the arming clip (5). Movement over the arming clip (5) causes the legs to bend inward slightly, permitting the arming sleeve (3) to move completely over the primer holder (7). With the arming sleeve (3) fully to the rear, the solid block it presented between the primer (6) and the firing pin (1) is removed. The arming sleeve is held to the rear by the spring action of the legs of the arming clip (5). The primer holder (7) and the arming sleeve (3) are locked together and held away from the firing pin by the anti-creep spring (2). Upon impact, the primer carrier (7) moves forward and the primer (6) is impaled upon the sharp pointed firing pin (1). The primer (6) flashing initiates the detonator-booster (9).

CHICOM POINT DETONATING IMPACT FUZE TYPE 9

d. Weapons and projectiles with which used.

Weapons	Projectiles	
60-mm: mortar Type 31 and Type 63	60-mm HE-Frag	Type ?
82-mm: mortar Type 53	82-mm HE-Frag	Type ?
120-mm: mortar Type 53	120-mm HE-Frag	Type ?

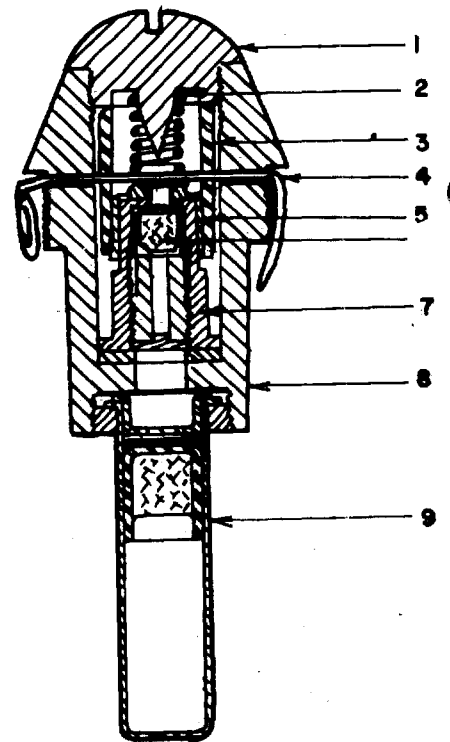
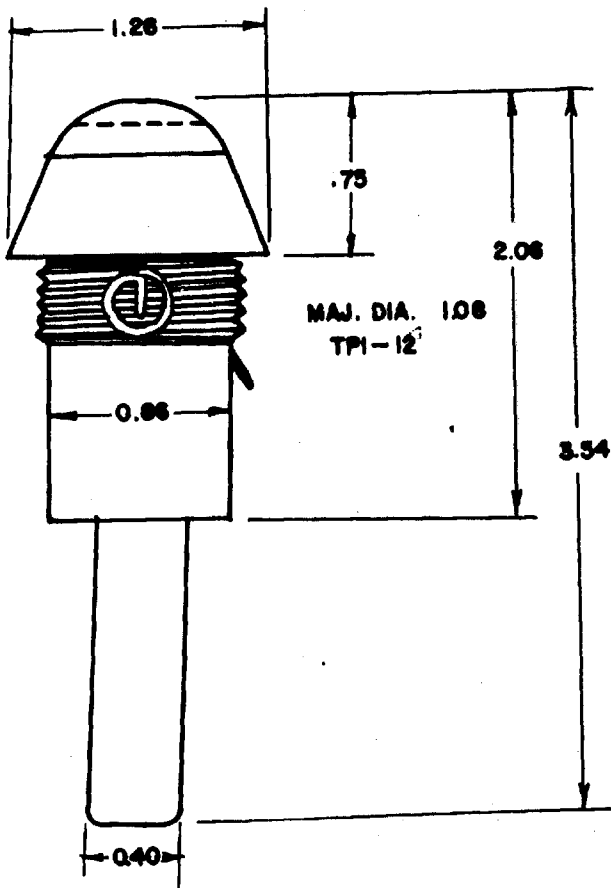

CHICOM POINT DETONATING IMPACT FUZE TYPE 12

a. General. The ChiCom Type 12 fuze is an exact copy of the Soviet M-12 mortar fuze. The Type 12 fuze is employed interchangeably with its Russian counterpart in 120-mm Mortar ammunition. For a description and functioning of the ChiCom Type 12, see the Soviet M-12 mortar fuze.

b. Characteristics.

Action ----- instantaneous and delay  
 Loaded weight ----- 536.3 gm. (1.18 lbs.)  
 Body material ----- steel

c. Functioning. The operation of the ChiCom Type 12 is identical to that of the Soviet M-12 mortar fuze.

d. Weapons and projectiles with which used.

Weapons	Projectiles
120-mm : ChiCom Type 53 Mortar	120-mm Frag-HE ----- ?

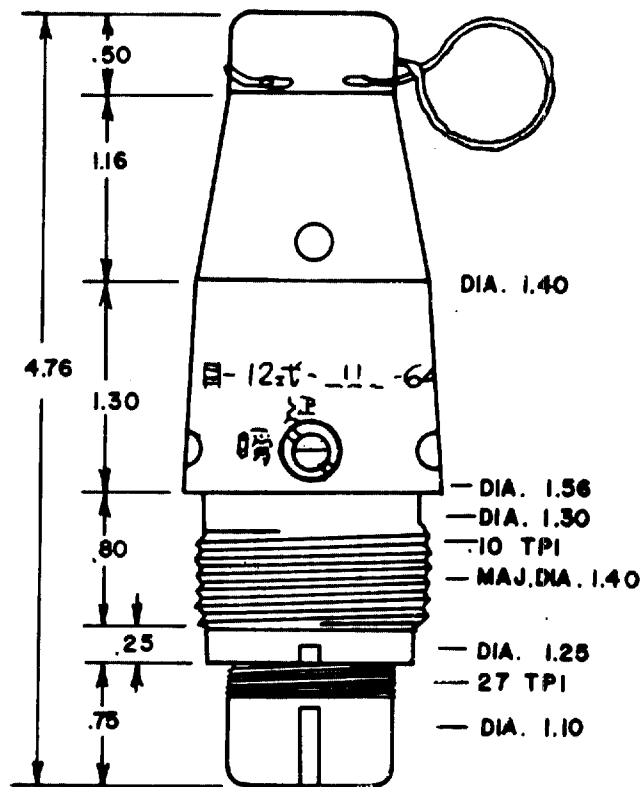

4-31/4-32

# CHICOM POINT DETONATING IMPACT FUZE TYPE 51

a. General. The drawing of this fuze has been made with information taken from two impacted fuzes that were removed from shell craters after detonation had taken place. Internally the fuzes were distorted and out-of-line. Some errors may therefore be expected in the internal configuration. The ChiCom Type 51 fuze was first encountered in Korea. It has been changed slightly in configuration, but basically the fuze is identical with its earlier counterparts. It employs five centrifugal detents nested together under the firing pin that prevent the firing pin from moving downward in the armed position. The detents are prevented from moving outward by a coiled brass spring. The detents are arranged so that they are interlocked and must rotate in a specific order to open the firing pin cavity. The removeable shipping cap may be removed for instantaneous fuze action or left on for non-delay action. Impacted fuzes have been recovered with caps painted red as well as unpainted. The color code is unknown. The Type 51 fuze is normally made in Communist China at a plant designated as Factory Number 524 and later as Factory Number 54.

## b. Characteristics.

Action ----- Instantaneous  
Loaded weight ----- 380 grams (0.83 lbs)  
Body material ----- Steel

c. Functioning. Upon firing, setback causes the firing pin (3) to move downward compressing its spring (4) and locks the centrifugal detents in position. As acceleration diminishes, the firing pin spring (4) moves forward permitting centrifugal force to act upon the detents. The first detent has its weighted end moved outward against the coiled spring (5), which has been expanded by centrifugal force. When the first detent has rotated out of the path of the second detent, the second detent rotates out of the path of the third. This action continues until all detents have rotated from beneath the firing pin. The fuze is now armed. Upon impact, the wooden plug drives the firing pin (3) down into the primer (8). When the nose cap (1) is left on, the wooden nose plug (2) and firing pin cannot move a sufficient distance to strike the primer (8). In this instance, the primer carrier moves forward impaling the primer (8) on the sharp pointed firing pin (3) producing a detonation.

## d. Weapons and projectiles with which used.

Weapons	Projectiles
105-mm: ChiCom howitzer Type ?	105-mm HE-Frag ----- Type ?

CHICOM POINT DETONATING IMPACT FUZE TYPE 51

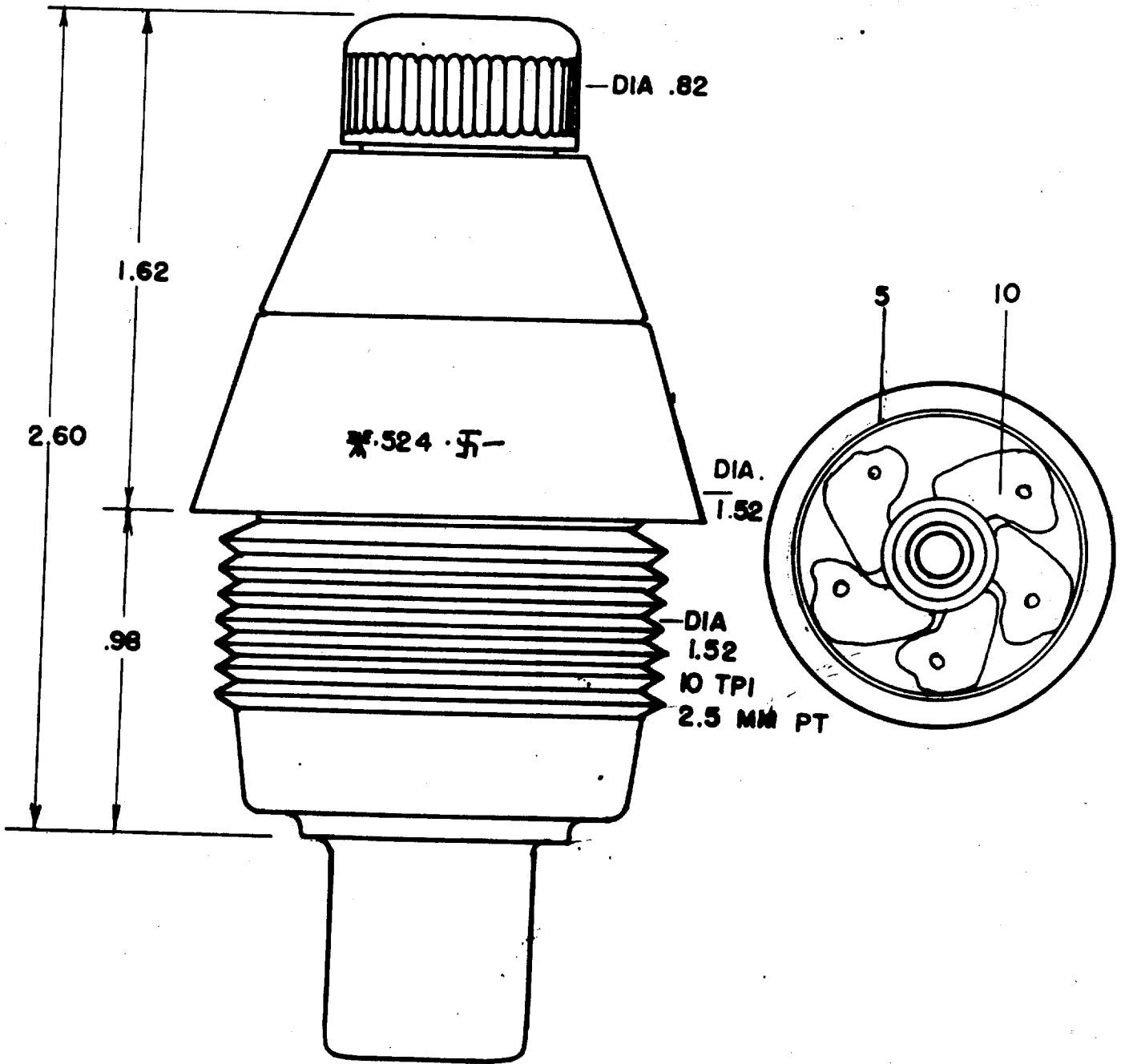

CHICOM POINT DETONATING IMPACT FUZE TYPE 51

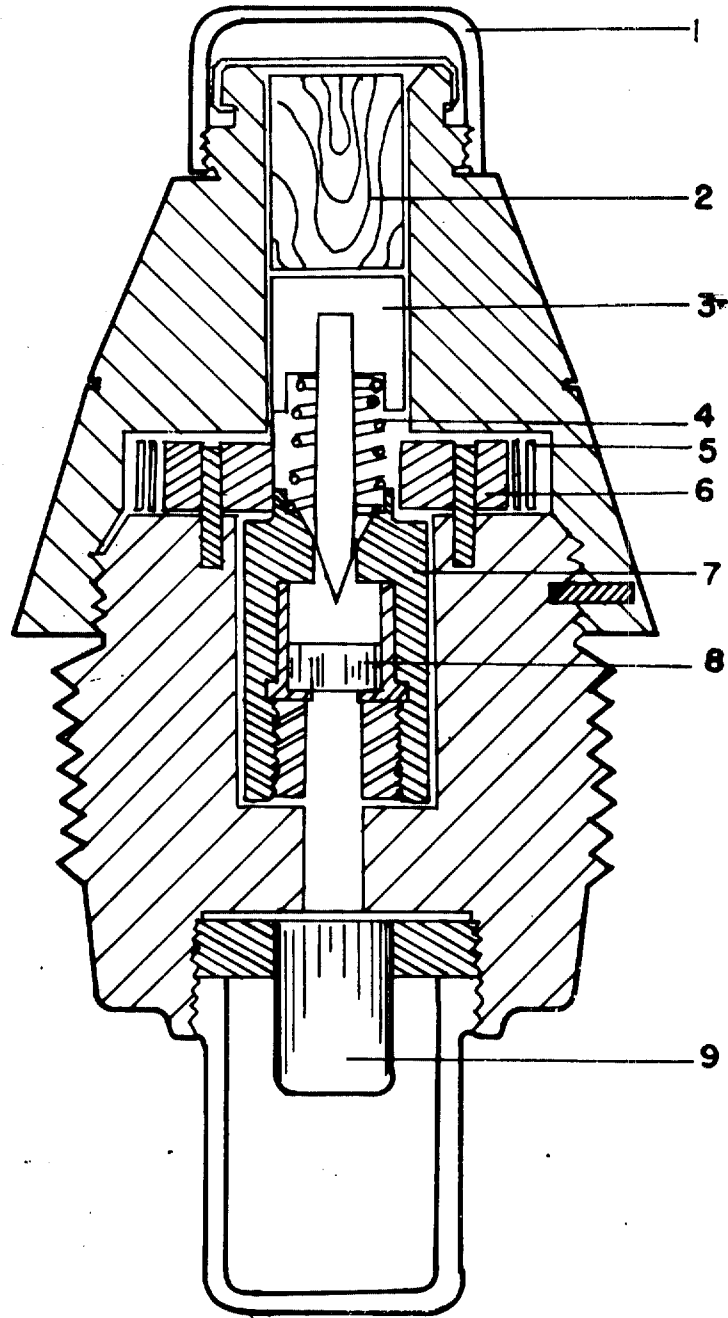

4-35/4-36

CHICOM POINT DETONATING IMPACT FUZE TYPE 53

a. General. The ChiCom Point Detonating Impact Fuze Type 53 is a copy of the ChiCom Type 51 fuze. Internally the fuzes are identical and function in the same manner. The only difference noted between the Type 53 and the Type 51 is that the Type 53 has a larger diameter booster, a thicker detonator, and a slightly longer detonator cavity. The Type 53 is the father of the improved Type 53 Mod 1 and Mod 2 fuzes being used in the 75-mm recoilless rifles.

b. Characteristics.

Action ----- Instantaneous  
Loaded weight ----- 380 grams (0.83 lbs)  
Body material ----- Steel

c. Functioning. Functioning is identical to that of the ChiCom Type 51 fuze.

d. Weapons and projectiles with which used.

Weapons	Projectiles
105-mm: ChiCom howitzer Type ?	105-mm HE-Frag ----- Type ?

CHICOM POINT DETONATING IMPACT FUZE TYPE 53

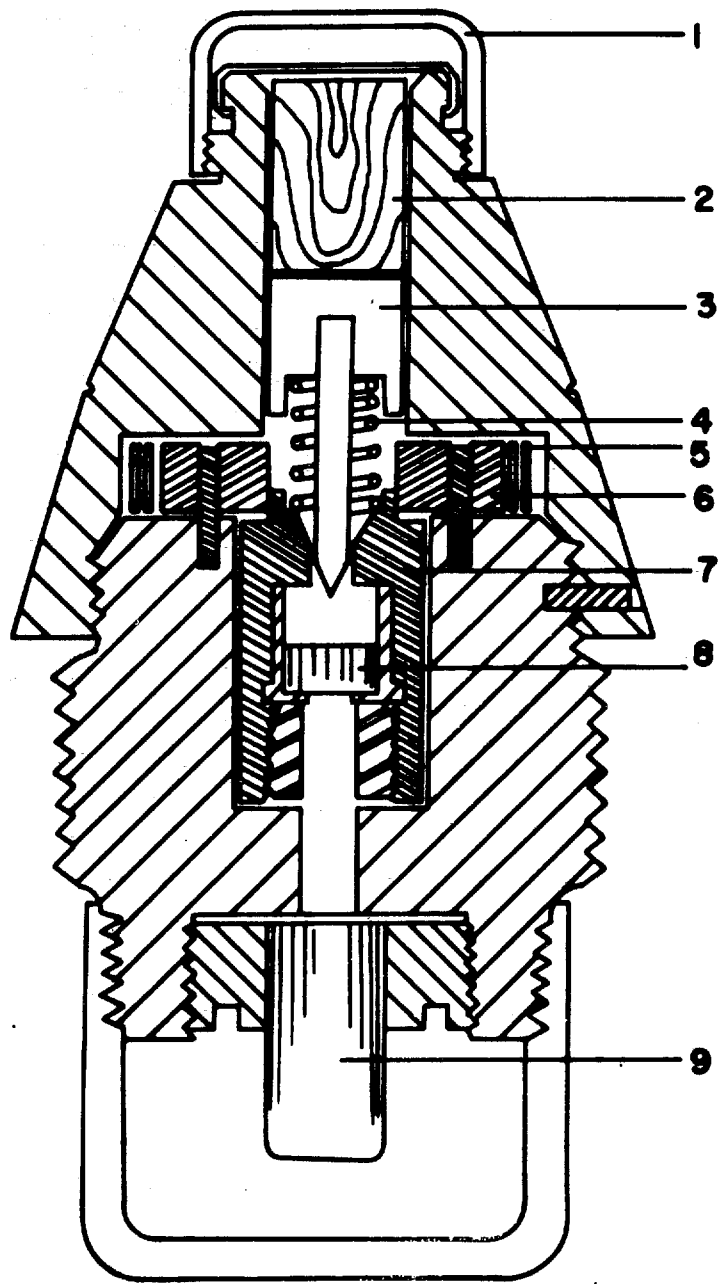

CHICOM POINT DETONATING IMPACT FUZE TYPE 53

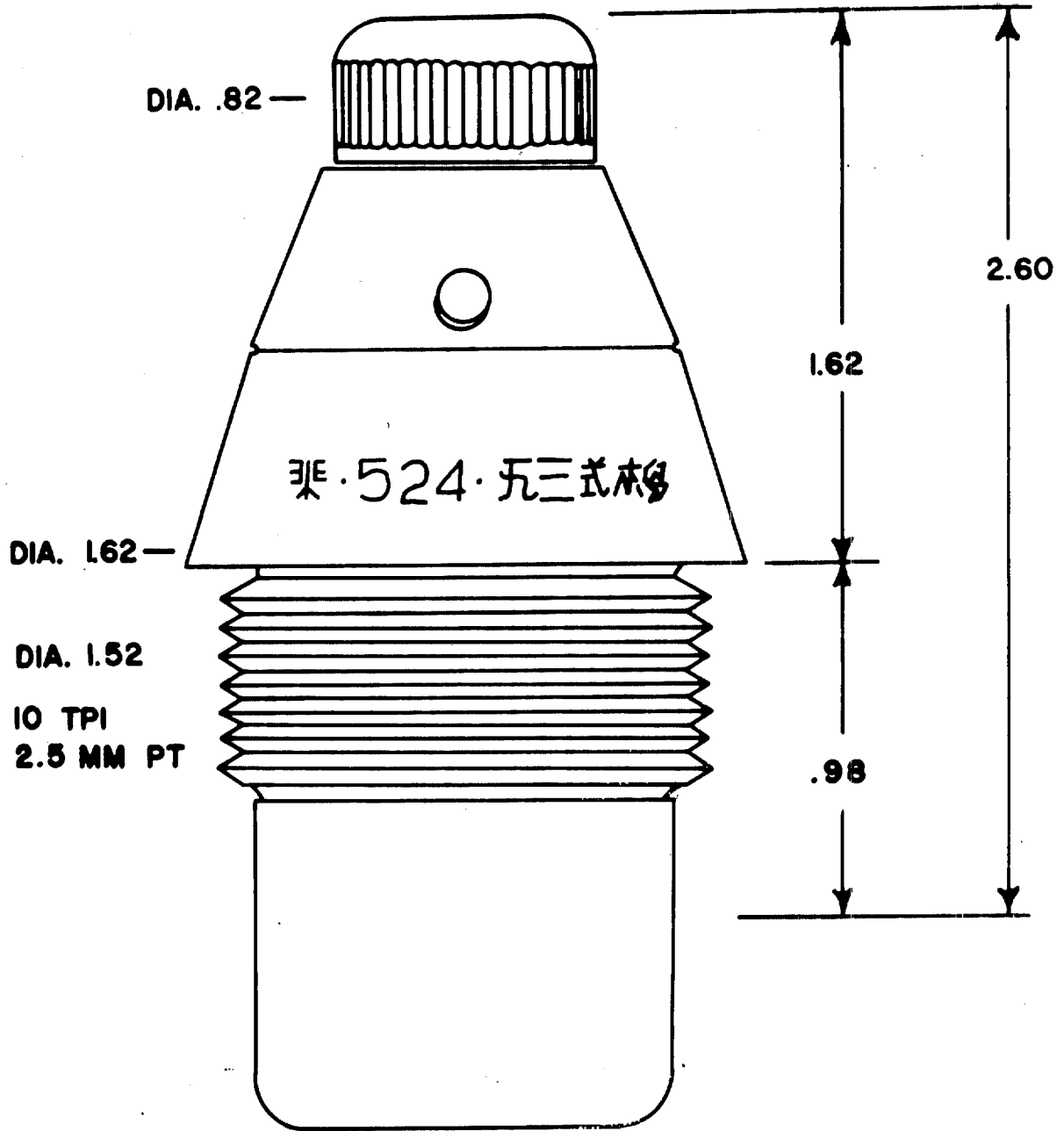

4-39/4-40

# CHICOM POINT DETONATING IMPACT FUZE TYPE 53 Mod 1

a. General. The ChiCom Type 53 Mod 1 fuze is practically identical to the earlier Type 51 and Type 53 ChiCom fuzes. The Type 53 Mod 1 uses the small booster seen on the Type 51. Construction and materials seem to be identical with the Type 53. The Type 53 Mod 1 is a centrifugal force armed, superquick action fuze that possesses a graze sensitive capability. The fuze is not detonator safe nor bore safe. It consists of an upper and lower fuze body machined from bar stock. A groove is cut into the fuze body surface at the junction of the upper and lower sections. This groove apparently has no purpose. The upper and lower bodies are secured by a single stake, rather than with a pin as in the Type 51 and Type 53 fuzes. Internally the fuze is identical with the Type 51 and Type 53 fuzes. It contains a firing pin assembly, with a wooden plunger and a steel firing pin spring. There are five brass centrifugal segments enclosed by a brass, coiled, leaf spring that form the arming elements. The primer assembly consists of a brass primer holder, two chip board spacers, a primer and a retaining slug. The centrifugal detents rotate on pins seated in the lower fuze body. The nose cap is painted red and the fuze body appears to be made from stainless steel.

## b. Characteristics.

Action ----- Instantaneous  
Loaded weight ----- 393 grams (0.86 lbs.)  
Body material ----- Steel

c. Functioning. When the round is loaded into the weapon is loaded, the firing pin (4) is seated on the coil spring (5) which holds the firing pin (4) above the centrifugal segments (7). The centrifugal segments are prevented from moving outward by the centrifugal spring (6). Upon firing, setback causes the firing pin to move rearward compressing the spring (5) until it is seated on the centrifugal segments, holding them in position. As acceleration ceases and centrifugal force increases, the spring forces the firing pin forward. The centrifugal segments rotate about their pins simultaneously as the centrifugal spring (6) expands. This leaves an unobstructed passage for the firing pin (4) to reach the primer (9). Creep action moves the firing pin forward into the nose of the fuze against the wooden plunger. The coil spring (5) prevents the primer holder from moving forward onto the firing pin. Upon impact, the firing pin is driven rearward by the wooden plunger. Impact at flat angles cause the primer holder to move forward permitting the primer (9) to hit the firing pin. This initiates the booster (11) which detonates the projectile.

d. Weapons and projectiles with which used.

Weapons

105-mm: howitzer Type ?

Projectiles

105-mm HE-Frag ----- Type ?

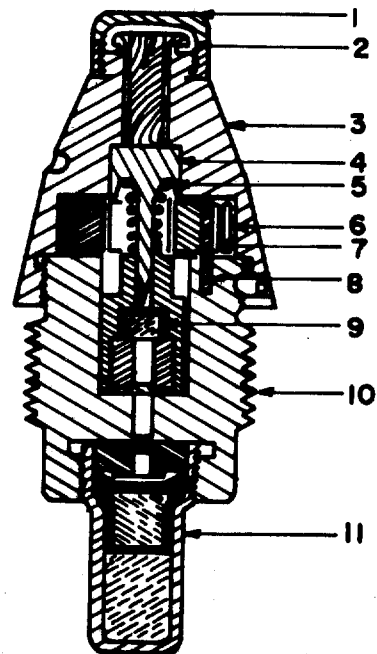
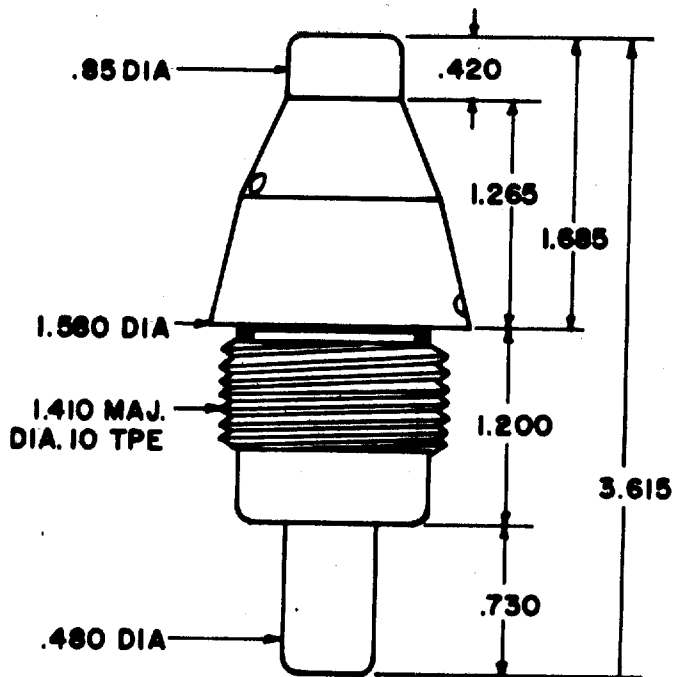

CHICOM, POINT DETONATING IMPACT FUZE, TYPE 53 MOD 2

a. General: The ChiCom type 53 mod 2 fuze is the latest fuze in the type 53 family that has been identified. All fuzes recovered of this type to date have been "sanitized". Markings were restored by etching. Externally the type 53 mod 2 appears identical to the type 1 and type 3 Special. All are employed on the 75mm Recoilless Rifle type 52. The cocked detonator fuzes, the type 1 and type 3, have slightly longer nose caps and a spanner wrench hole between the shoulder and threads. The type 53 does not possess the hole. All nose caps of the type 1 and type 3 are also black, while the type 53 nose cap is cadmium plated.

The type 53 mod 2 is practically identical internally with the earlier type 53 fuzes. The modification consists of the addition of a set-back pin and spring that blocks outward movement of the key centrifugal detent. The set-back pin must remain down long enough for the key detent to move outwards. This is provided by sustained acceleration.

b. Characteristics:

Action ----- Instantaneous  
Loaded weight ----- 399 grams (0.88 lb)  
Body material ----- Steel

c. Functioning: Upon firing, set-back causes the set-back pin (13a) to move downward and remain in this position throughout sustained acceleration. When centrifugal force overcomes the friction produced by set-back, the key detent (7) permits the remaining detents to pivot outward in sequence. When all base pivoted from beneath the firing pin (5) the fuze is armed. Creep action causes the lockout sleeve (9) to move forward and prevents the centrifugal spring from forcing the detents (7) to return to their original positions upon spin delay. With the detents (7) locked out by the sleeve (9) the firing pin (5) is separated from the detonator (11) by the anticreep spring (6).

Upon impact the firing pin (5) is driven downward by the impact plunger (3) piercing the detonator (11). The detonator (11) flashes through flash channel initiating the lead cup (15) and boosters (16). If the projectile impacts at a flat angle, or the nose cap (1) was left in position, the detonator housing (10) slides forward in its cavity impaling the detonator (11) on the primer, initiating fuze action. This twin movement of the firing pin and detonator is characteristic of the new Soviet/ChiCom fuze series and results in excellent fuze confidence.

d. Weapons and projectiles with which used:

75mm: ChiCom Type 52 RR                      75mm RR HE ----- type 52

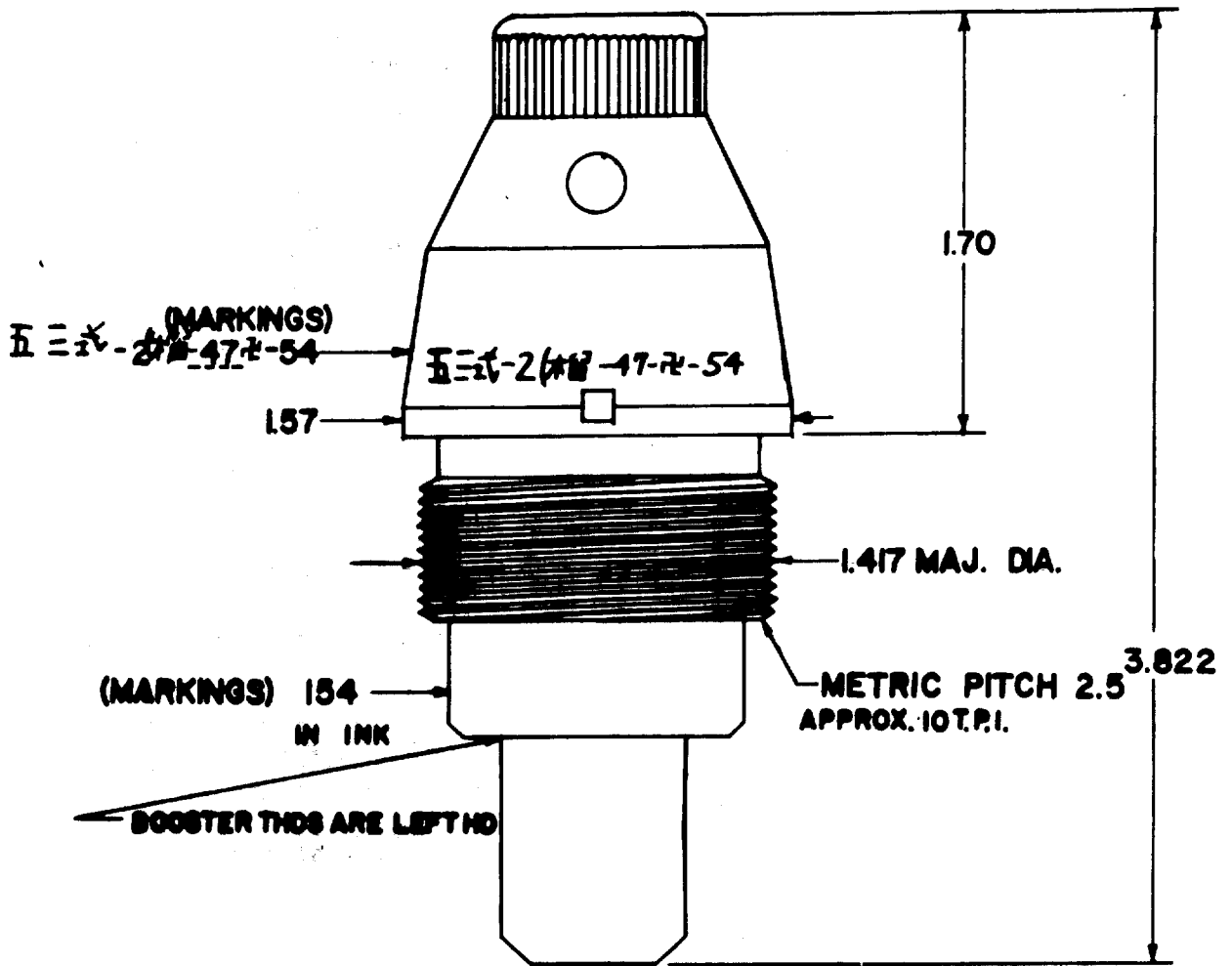

CHICOM POINT DETONATING IMPACT FUZE, TYPE 53 MOD 2

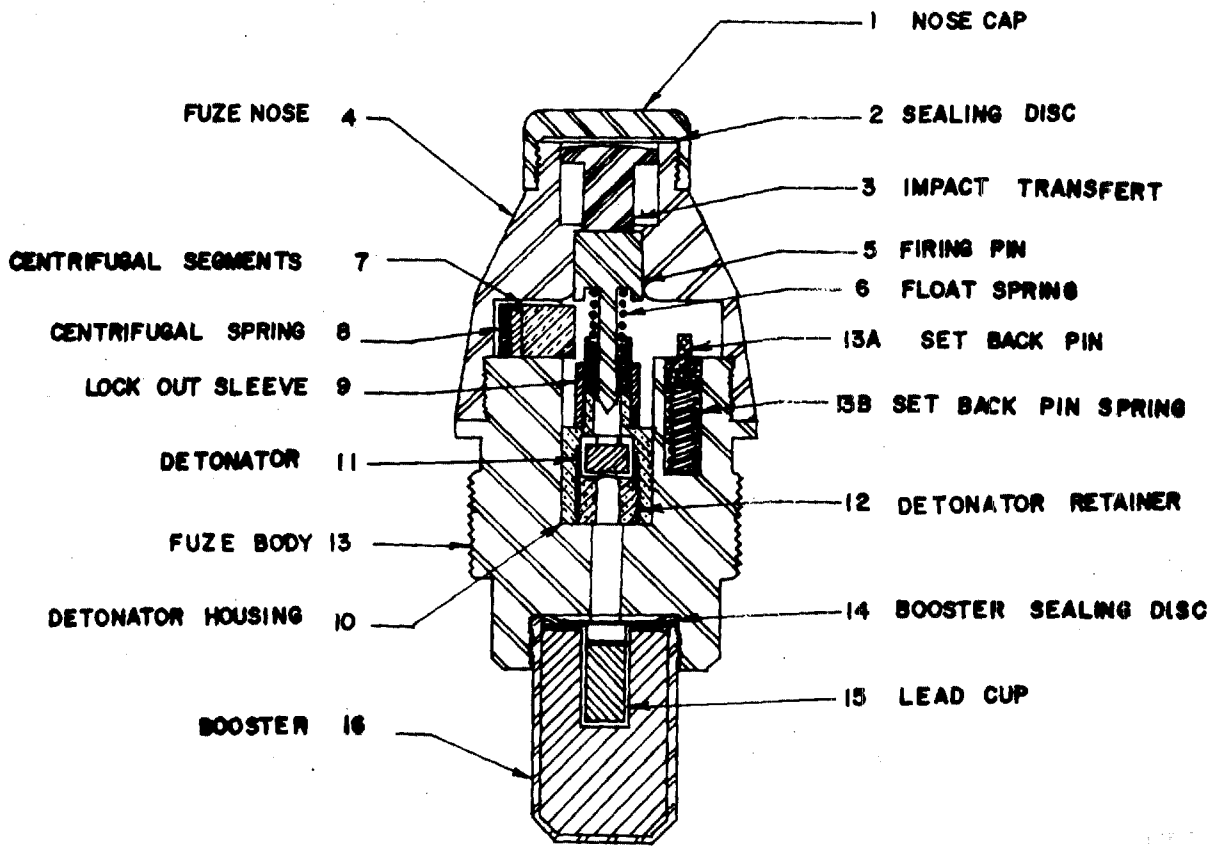

4-45/4-46

# CHICOM POINT DETONATING IMPACT FUZE TYPE 88

a. General. The ChiCom Type 88 point detonating fuze is an exact copy of the World War II Japanese Type 88 fuze. Prior to and during the Korean War, the fuze was produced for several applications. In Viet Nam it has been observed only on the ChiCom copy of the Japanese 70-mm howitzer projectile. According to markings, the fuze was produced in North East China (Manchuria) by factory 724. This factory, plus factory 524 were noted for their fuze production during the Korean War.

The Type 88 fuze is bore safe, but is not detonator safe. It is made of brass and employs the typical Japanese "gaine" explosive train. The upper fuze body (8) threads into the lower fuze body (10) by left hand threads. The gaine has right hand threads. All threaded sections are secured by stab crimps. The fuze is given a coating of varnish to render the fuze corrosion resistant. No effort was made toward water-proofing. The firing pin plunger (1) is machined from aluminum. The firing pin (11) is steel.

## b. Characteristics.

Action ----- Instantaneous  
Loaded weight ----- 170 grams (0.37 lbs)  
Body material ----- Brass

c. Functioning. The safety fork (9) must be removed prior to firing. Upon firing, setback causes the setback sleeve (2) to move rearward compressing the four legs of the stirrup (4). When the internal circumferential groove in the setback sleeve (2) is presented to the legs of the stirrup (4), these legs snap into the groove locking the set-back sleeve (2) to the stirrup (4). This frees the four safety segments (3) which are moved from under the firing pin (11) by centrifugal force. The fuze is now armed. Upon impact, the plunger is driven downward which permits the firing pin (11) to pierce the primer (5) initiating the detonator (6), which functions the projectile.

## d. Weapons and projectiles with which used.

Weapons	Projectiles
70-mm: ChiCom copy of Japanese Type 92 howitzer	70-mm HE-Frag --- ChiCom Type ?

CHICOM POINT DETONATING IMPACT FUZE TYPE 88

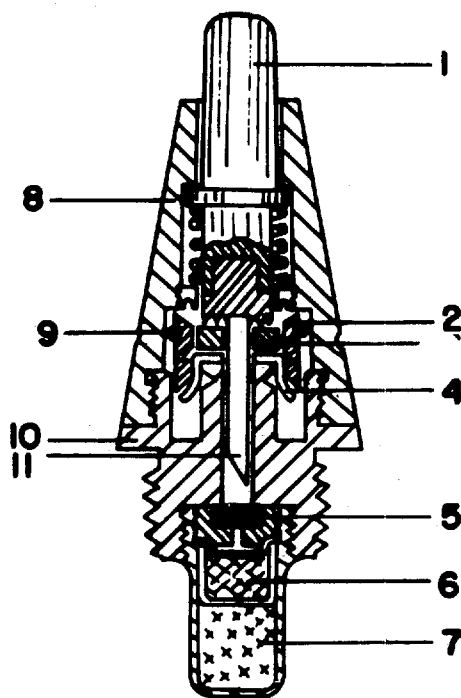
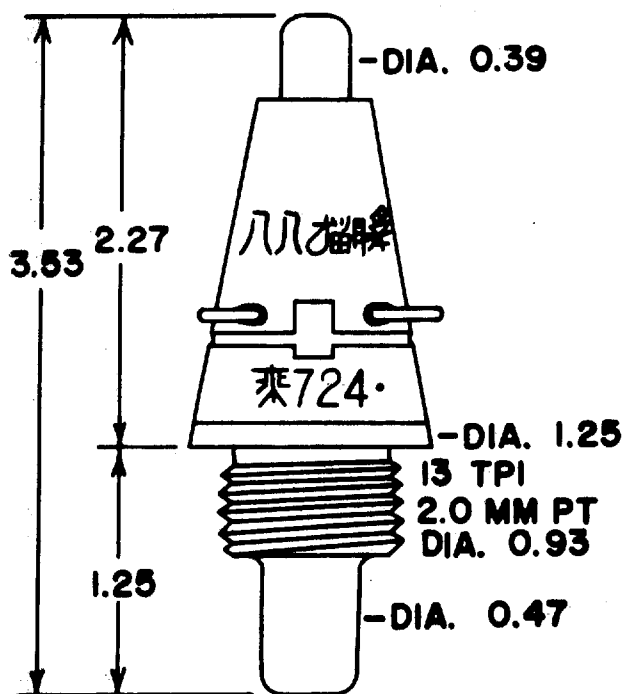

CHICOM POINT DETONATING IMPACT FUZE TYPE 100

a. General. The ChiCom Type 100 point detonating fuze represents the early type ChiCom fuzes that appeared during the Korean War and is now obsolete. Its application has been assumed by other more modern fuzes. The current ChiCom Type 100 has not been examined internally due to the lack of a serviceable sample for exploitation. However, its functioning appears to be similar to the Soviet M-50. A more detailed description will be supplied at a later date.

b. Characteristics.

Action ----- Instantaneous

Loaded weight ----- ?

Body material ----- Steel

c. Functioning. Detailed functioning will be supplied at a later date.

d. Weapons and projectiles with which used.

Weapons	Projectiles
60-mm: mortar Type 53	60-mm HE-Frag ----- Type ?
102-mm: rocket launcher Type ?	102-mm HE-Frag ----- Type 488

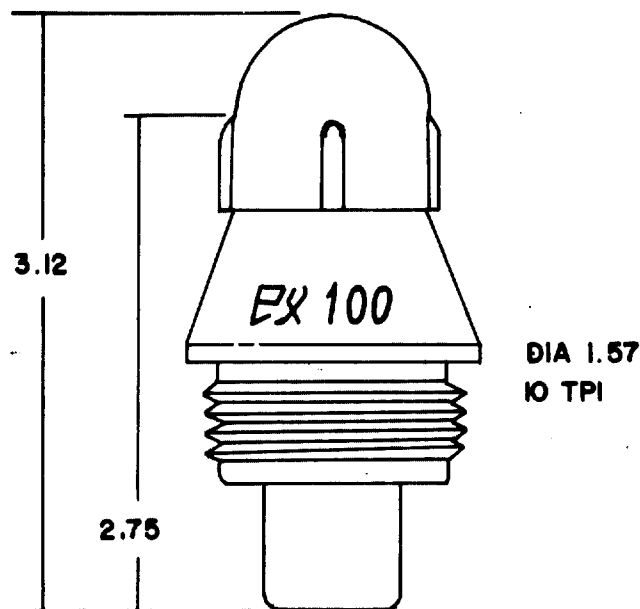

4-49/4-50

## CHICOM POINT DETONATING IMPACT FUZE 100-3

a. General. The ChiCom 100-3 is the latest in the evolution of the old Korean War "Universal" series fuzes. The early fuzes, could, with slight exception, be employed on the 60-mm, 81-mm, 82-mm, and 120-mm mortar projectiles. Currently the 100-3 fuze is employed only on the 60-mm Mortar. Several variants of the 100-3 exist; however, the variations are in body materials and the method by which the shipping cap is attached to the body. Bodies have been seen made of aluminum with the steel shipping cap threaded to the body. Other bodies have been of phenolic plastic with the shipping cap attached by a semi-circular clip engaging slots in the cap that are aligned with similar slots in the body. The shipping cap is removed prior to firing. The 100-3 is entirely waterproof. The opening in the nose of the body is sealed with a foil disc which in turn is sealed with a ring crimp around the nose. The booster opening is sealed with either a lead washer and glue or plastic washer and glue. The only safety device in the 100-3 is the shear wire and the fact that the primer is held stationary by the locking plate and locking plate spring. The locking plate is also held rigid by a bulkhead in the inner fuze cavity.

### b. Characteristics.

Action ----- Non-delay

Loaded weight ----- 129.5 grams (0.28 lbs.)

Body material ----- Aluminum or plastic

c. Functioning. The shipping cap (1) is removed prior to firing. The closing cup (2) and the primer housing (4) are held immovable by the shear pin (3). These, in turn, block the firing pin (6) and firing pin disc (5) in position. The primer (9) is held in its position at the bottom of the primer housing (4) by a locking plate (8) which rides in slots cut through the primer housing (4). The plate is held stationary by its lugs riding in the recesses cut into the inner fuze cavity bulkhead. The locking plate spring (7) assists in maintaining the locking plate (8) and primer (9) in the lower end of the primer housing (4) if the shear pin (3) is sheared by set-back. Upon impact, the shear pin (3) is sheared and the primer housing (4) is moved rearward by the closing cup into the inner fuze cavity. The firing pin (6) and firing pin disc (5) are also forced rearward by the closing cup (2). The primer (9) moves forward by inertia, sliding the locking plate (8) ahead of it. The locking plate (8) moves in the slots cut in the primer housing (4), compressing the locking plate spring (7). The primer and firing pin (6) make contact, initiating the primer (9), which functions the detonator and booster (11).

CHICOM POINT DETONATING IMPACT FUZE 100-3

d. Weapons and projectiles with which used.

Weapons

Projectiles

60-mm: ChicCom Type 31 and Type 63

60-mm HE-Frag ----- Type 7

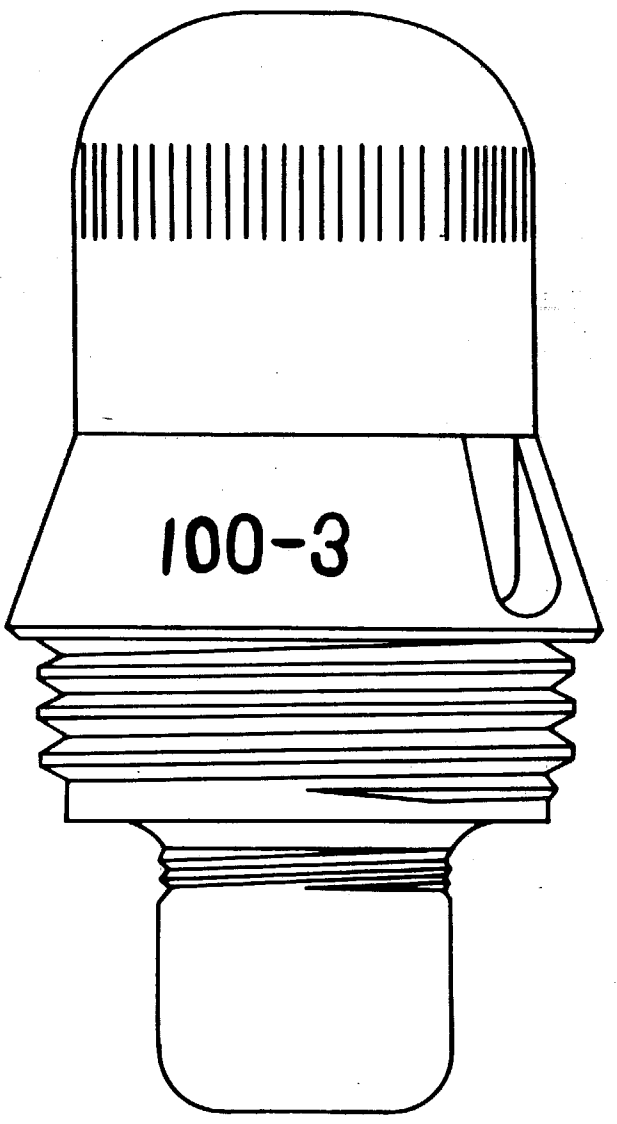
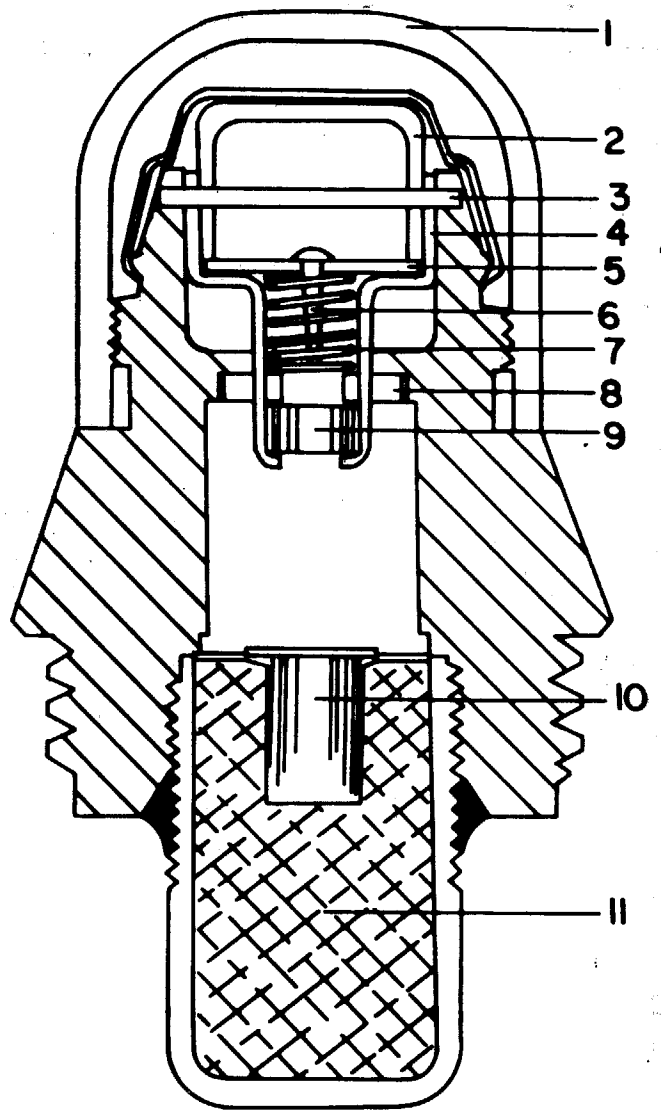

CHICOM POINT DETONATING IMPACT FUZE TYPE 429

a. General. The ChiCom Type 429 is an exact copy of the Soviet V-429 fuze. Design, materials and workmanship appear to be identical between the two fuzes. Further details can be found in the section covering the Soviet V-429 fuze.

b. Characteristics.

Action ----- instantaneous & delay

Loaded weight ----- 434 gms. (0.95 lbs)

Body material ----- steel

c. Functioning. The operation of the ChiCom Type 429 fuze is identical to that of the Soviet V-429 fuze.

d. Weapons and projectiles with which used.

Weapons

Projectiles

Same as Soviet V-429

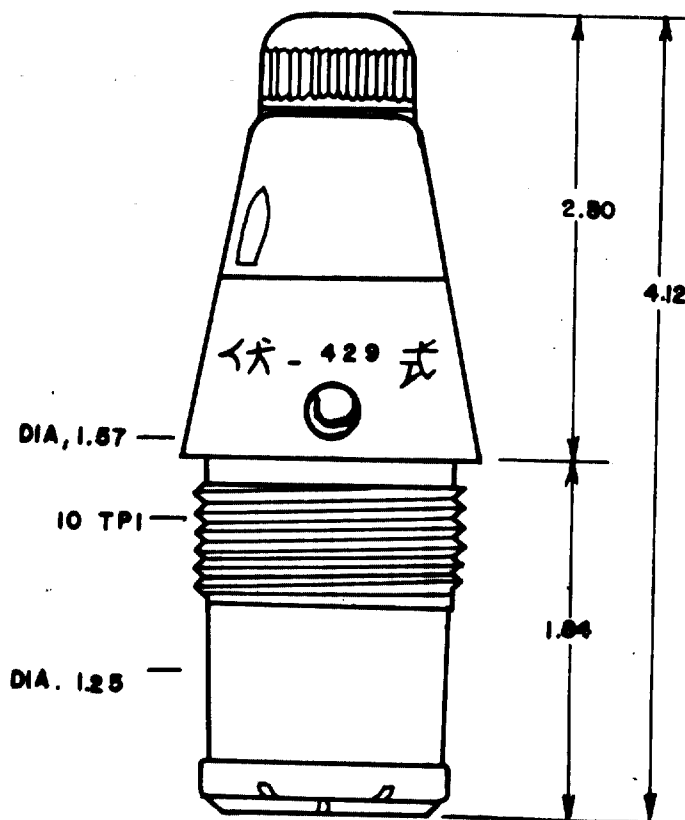

CHAPTER 5

SOVIET BASE DETONATING FUZE

5-1.1

## SOVIET BASE DETONATING FUZES

The major population of all base detonating fuzes employed by the Communist bloc are direct copies or modifications of Soviet Base Detonating Fuzes. The Soviet fuzes, when taken as a group are conventional in all respects and offer few remarkable features. The mechanical characteristics of individual fuzes, especially in later designs, possess features that reveal a positive trend toward increased safety in handling and firing. The piezo-electric VI-7 displays the greatest departure from standard Soviet Base Detonating fuze design. This fuze is the first piezo-electric recovered, revealing positive Soviet acceptance of the importance of the principle. It also is the first detonator safe base detonating fuze, incorporating a vertically sliding detonator carrier in lieu of the normal detonator rotor.

Soviet base detonating fuzes are employed in concrete piercing and armor piercing ammunition that is fired from field, anti-tank, or anti-aircraft artillery or grenade and rocket launchers. All Soviet base detonating fuzes, less the point initiating, base detonating types, are designed to function by impact inertia. Some incorporate delay pellets that may have the conventional pressed black powder pellet or the newer, non-aseous, di-chromate pellet. A few base detonating fuzes have an automating deceleration discrimination feature that acts as a delay feature to regulate delay fuze functioning until the projectile has achieved complete target penetration, regardless of target thickness.

The Soviets expend the same effort upon environment proofing base detonating fuzes as they do upon the other fuze classes. Lead sealing rings, nylon pipe threads sealant, plastic rings and sealing compounds are all employed for complete water proofing. Although base detonating fuzes are mounted inside explosive ordnance and do not require the same lavish effort toward environment proofing, it appears that current Soviet munition design philosophy requires that all explosives receive this treatment.

Base detonating fuzes receive the same care in marking as do the other classes of fuzes. Each is die stamped with the fuze designation, lot number and factory, when space permits. Those base detonating fuzes that are permanently mounted in projectiles are marked on body flanges so that the information can be read directly from that portion of the fuze that protrudes from the projectile.

## SOVIET BASE DETONATING IMPACT FUZE, DBR

a. General. The base detonating fuze DBR is new in the Soviet inventory and has been seen only in large caliber armor piercing projectiles. It features a delay pellet to provide maximum penetration of projectile prior to detonation. Its companion fuze, the DBR-2, does not possess a delay pellet. Basic functioning of the DBR and DBR-2 fuzes are nearly identical.

The DBR is fired directly by impact inertia and has a graze sensitive weight (14) in the bottom that is retained in position by a thin metal clip (15). This same type arrangement is employed in the GK-2 series fuze. The arming mechanism is contained within a cylindrical housing (24). This housing contains the primer carrier (13) and primer (21). This assembly is also the inertial assembly that causes fuze functioning upon impact. The primer carrier (13), thereby, securely locking the carrier against all movement. The detents are prevented from moving outward until set back ceases by a set-back collar (11) which moves rearward covering the detent stems (24). Upon impact, an impact collar (23) moves forward restraining the detents (22) from moving inward under the influence of their springs. The detents (22) are retained in their cavities by the detent springs and a hollow cap.

An anti-creep spring (9) maintains separation of the primer carrier (13) and the fixed firing pin (7) when the fuze is armed. The primer end of the anti-creep spring (9) contains a de-sensitizer cup (10). The cup has a central hole for the firing pin to pass through, but the hole is smaller in diameter than the firing pin. It requires more than a normal amount of force for the firing pin to enlarge the hole so that it can reach the primer (21).

The firing pin (7) rests on top of the delay pellet (6). The firing pin has three holes through its body and grooves in its side to permit flame from the primer (21) to reach the delay pellet (6). The delay pellet is pressed black powder and possesses three deep depressions in its upper surface to increase its ignition area. The delay pellet (6) and fixed firing pin (7) are secured in the delay pellet housing by a threaded slug (8). The entire assembly threads into an adapter (20) that screws into the fuze body. The booster (1) contains the detonator (3) and detonator cushion (2). These components are retained in the booster cup by the threaded plugs (4) and (5).

The tracer element (17) is contained in an aluminum cup that is sealed at its open end by a celluloid disc (18). Two gas escape ports (16) are drilled through the tracer housing to permit hot air to escape so that the tracer will not be blown from the tracer housing.

The fuze is entirely water proof. The booster (1) is sealed to the fuze body by a vinyl ring and a lead crush ring (19). In addition the fuze is secured to the fuze adapter by a lead crush ring (25). The presence of the ring (25) requires considerable force to remove the fuze from the adapter.

The DBR fuze is bore safe, but is not detonator safe by U.S. standards. Arming is by centrifugal force only. Firing is accomplished by straight impact through the inertia movement of the primer carrier (13) or upon graze impacts by the lateral movement of the graze weight (14) forcing its way through the legs of the clip (15). This action cams the primer carrier (13) onto the firing pin (7).

**b. Characteristics.**

Action ----- Impact inertia

Loaded weight ----- 430 grams (0.94 lb)

Body material ----- Steel

**c. Functioning.** When the round is fired, set-back causes the set-back collar (11) to move downward compressing its spring (12) and covering the detents (22) so they cannot retract until after set-back diminishes. When set-back ceases the spring (12) forces the collar (11) forward uncovering the detents (22). Centrifugal force, acting on the three detents (22) cause them to be withdrawn from the annular groove in the primer carrier (13). This compresses the detent springs. With the detents withdrawn from the primer carrier (22) the fuze is now armed. The carrier is prevented from moving forward only by the anti-creep spring (12).

Upon impact the impact collar (23) moves forward against the spring (12) restraining the detents (22) from prematurely moving inward locking the primer carrier (13). Simultaneously, inertia causes the primer carrier (13) to move forward compressing the anti-creep spring (9) and seating the desensitizer cups (10) and primer (21). The primer then flashes through the grooves and holes in the firing pin housing (7). The flame ignites the delay pellet (6) which, in turn, flashes into the flame sensitive detonator (3). This initiates the booster (1) and projectile.

If the projectile impacts at flat angles the graze weight (14) is forced laterally by inertia. The graze weight (14) bends down one or more of the legs of the clip (15) carrying the weight. With the weight (14) free it continues to move laterally so that its conical cam surface contacts the cam on the primer carrier (13) forcing the carrier forward onto the firing pin(7). Action then continues as described.

**d. Weapons and projectiles used with.**

122mm: Soviet gun D-74

122mm Soviet APC BC HE-7-BR-472

SOVIET BASE DETONATING IMPACT FUZE, DBR

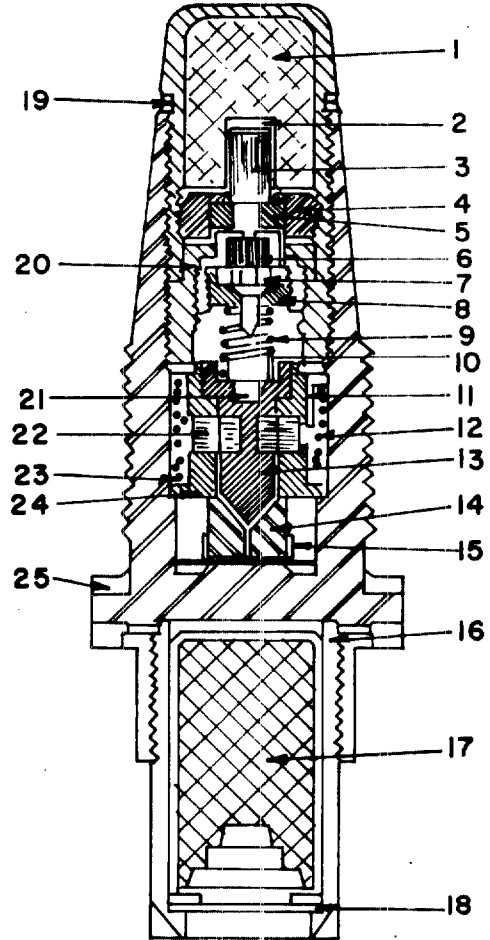
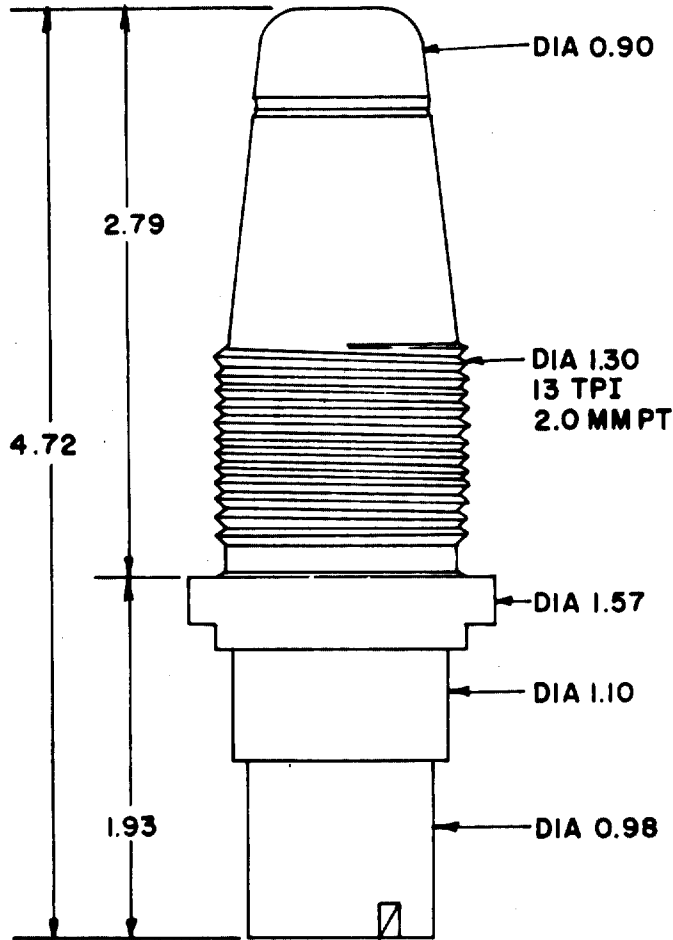

5-3/5-4

a. General. The DBR-2 base detonating fuze represents the second fuze in the DBR series. These fuzes are a new series of simple, reliable, well built, bore safe fuzes introduced into the Soviet arsenal since 1950. The only major fault the fuze possesses, by American standards, is that it is not detonator safe. Arming is by centrifugal force only.

The DBR-2 has a tracer element (18) that threads into the fuze body (28) and becomes an integral part of the fuze. The tracer composition (18) is pressed into an aluminum cup (17). The cup, in turn, is pressed into the tracer housing (29). The tracer composition is waterproofed and protected by a celluloid disc (30) positioned at the mouth of the tracer housing (29). The tracer element is stepped to increase its ignition surface. The fuze body and tracer housing (29) have pressure escape ports (16) drilled into the tracer cavity.

The arming element of the fuze consists of a cylindrical housing containing the moveable primer carrier (27) and three centrifugal detents (12) that lock the primer carrier until setback ceases and centrifugal force overcomes the detent springs (13). The detents (12) are spring loaded downward and fit into an annular groove cut into the primer carrier (27), thereby securely locking the carrier against all movement. The detents are prevented from moving outward until after setback ceases by a setback collar which moves downward covering the detent stems (12). Upon impact, an impact collar (14) moves forward restraining the detents from moving inward under the influence of their springs (13). The detents are retained in their housing by the detent spring (13) and the "Do-Nut" shaped cap (11).

An anti-creep spring (23) maintains separation of the primer carrier (27) and the fixed firing pin (8) when the fuze is armed. The small diameter of the spring surrounds the firing pin (8).

The firing pin-relay-detonator-booster assembly is combined into one assembly and is threaded into the fuze body. The firing pin assembly (8) consists of a hollow, threaded plug that is threaded into the open end of the booster housing (2). The firing pin housing (9) possesses a vertical and horizontal, combination flash channel and gas expansion channel (7). These channels relay flame from the primer to the flash pellet (6). The flash pellet consists of a wheel and hub shaped assembly. The wheel is perforated with by-pass flash holes. The center of the wheel has a single tapering hole filled with a flash composition (6). The flash pellet assembly (6) is maintained in correct position with the flash channel in the retaining cup (21) by a single coil lock spring.

The detonator is covered by a convex plate (5) that has a single flash hole in the center. This insures that only the flame from the flash pellet (6) reaches the detonator (3). The detonator (3) rests inside an aluminum collar (20) that seats on shoulders inside the booster cup (2). The collar rests on a lead and felt ring. The open end of the detonator is closed by a cap, perforated by a single hole.

The booster cup is sealed in the fuze body (28) by a lead caulking ring (4) that is pressed into an annular dovetail groove cut into the base of the fuze body. The fuze body is sealed to the projectile body by a

lead crush washer (26). The combination of these lead rings effectively seal and waterproof the fuze.

b. Characteristics.

Action ----- Impact inertia  
 Loaded weight ----- 372 grams (0.81 lbs)  
 Body material ----- Steel

c. Functioning. When the round is fired, setback causes the setback collar to move downward, compressing the spring (25) and covering the detent cups (11) preventing the detents (12) from retracting until after acceleration ceases. As setback diminishes, the spring (25) forces the setback collar (10) forward uncovering the detent stems (12). Centrifugal force acting on the three detents (12) cause them to move outward, compressing their springs (13). With the detents withdrawn from the annular groove in the primer carrier, the carrier is prevented from moving forward only by the anticreep spring (23). The fuze is now armed. Upon impact, the impact collar moves forward putting frictional restraint on the detent. This is done to prevent them from moving inward prematurely. Simultaneously, inertia causes the primer carrier (27) to move forward against the anti-creep spring (23) permitting the primer (24) to impale itself on the fixed firing pin (8). When the primer (24) flashes, flame and hot gasses pass into the flash channels (7), igniting the flash pellet (6). The flash pellet sends its flame through the flash channel in the convex plate (5) into the heat sensitive detonator (3). This causes the detonator (3) to initiate the booster and projectile main charge.

If the projectile strikes at a flat angle so that friction restrains the forward movement of the primer carrier (27) the split, graze sensitive cam weights (15) move laterally coming the primer carrier into the firing pin, producing functioning.

d. Weapons and projectiles with which used.

Weapons	Projectiles
100-mm: field gun M1944; tank gun M1944 (D10-T); AA gun KS-19 SP assault gun M1944	100-mm APCBC-T ----- BR-412D

SOVIET BASE DETONATING IMPACT FUZE DBR-2

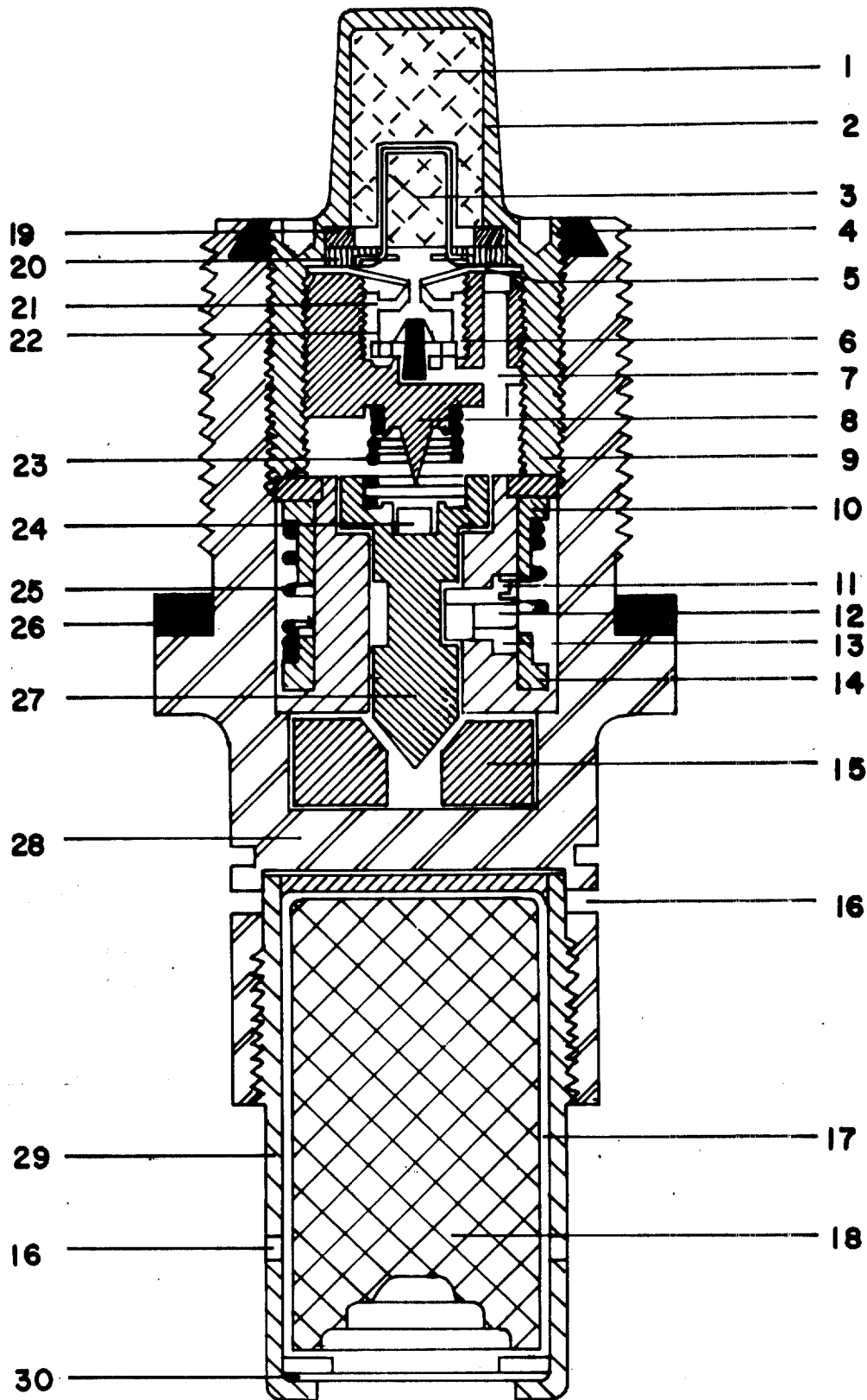

SOVIET BASE DETONATING IMPACT FUZE DBR-2

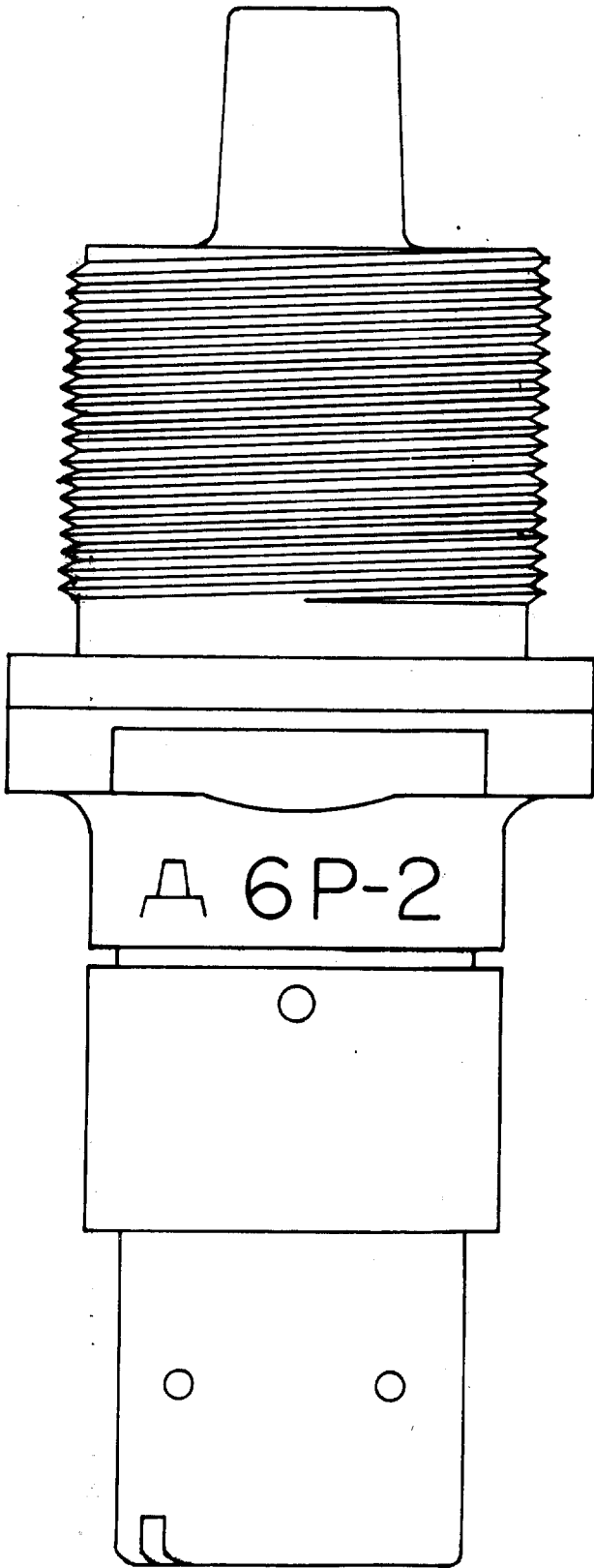

11  
13  
12  
27  
10

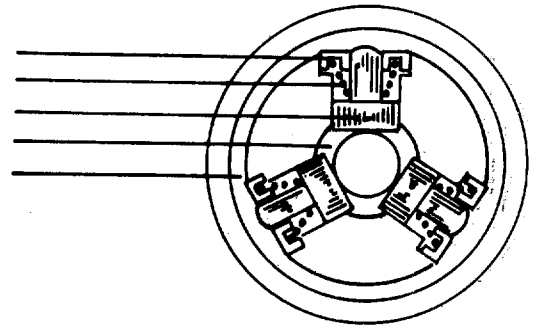

## SOVIET BASE DETONATING IMPACT FUZE MODEL DK-2

a. General. The Soviet base detonating fuze DK-2 is one of the many in the Soviet family of fuzes that employ the Zig-Zag delay arming feature originated by the French and employed in the ENERGA rifle grenade.

The DK-2 is set back armed, impact fired and contains a graze sensitive feature. The in-line explosive train classifies the fuze as non-bore safe.

The DK-2 is a small, hollow cylinder with a separate booster (1) crimped to the fuze body. The detonator (2) is retained in the end of the fuze by a threaded, hollow, plug. The fuze end cap (8) is threaded into the fuze body. The firing pin (9) is weighted, containing a lead core. It has a transverse plunger (5) with a large lug at one end and a smaller one on the other end. The plunger is spring loaded toward the small lug. The firing pin assembly (10) resides inside a sleeve (11) flanged at the rear. The tube has a longitudinal slot to accommodate the small end of the plunger after setback and a single opposed hole for the larger plunger end. The Zig-Zag sleeve (4) contains two opposed Zig-Zag slots. One narrow one for the small plunger end and a wider one for the large end. The set-back spring (6) is compressed between the inner sleeve (11) and the Zig-Zag sleeve. In the unarmed condition, the larger end of the transverse plunger (5) is in its slot. The small plunger end is depressed inside the firing pin assembly (10) by the Zig-Zag sleeve (4). The large plunger end protrudes into the small hole in the flanged sleeve locking the firing pin to the fixed sleeve against all movement, until setback.

### b. Characteristics.

Action ----- non-delay

Loaded weight -----

Body material -----

c. Functioning. Upon firing, setback causes the Zig-Zag arming sleeve (4) to compress the setback spring (6) as it moves rearward. The end of the transverse plunger (5) rides through the large Zig-Zag slot to the forward end of the sleeve. This allows the small end of the plunger to move to the right, forced by the plunger spring (10), and into the small slot. The setback spring (6) then forces the sleeve forward. The Zig-Zag slot causes the sleeve to move forward by a reciprocating action. This action produces sufficient arming delay until the grenade has traveled a safe distance from the launcher. Upon impact, the striker assembly (9) moves forward overcoming the anti-creep spring (3) and the sharp pointed firing pin pierces the primer detonator. This initiates the detonator and booster. If the round impacts at a low angle, the steel

SOVIET BASE DETONATING IMPACT FUZE MODEL DK-2

hammer (7) placed below the striker assembly (9) moves laterally in its cavity carrying the firing pin assembly into the primer detonator.

d. Weapons and projectiles with which used.

Weapons

Projectiles

RPG-2 Anti-Tank Grenade Launcher.

PG-2 grenade

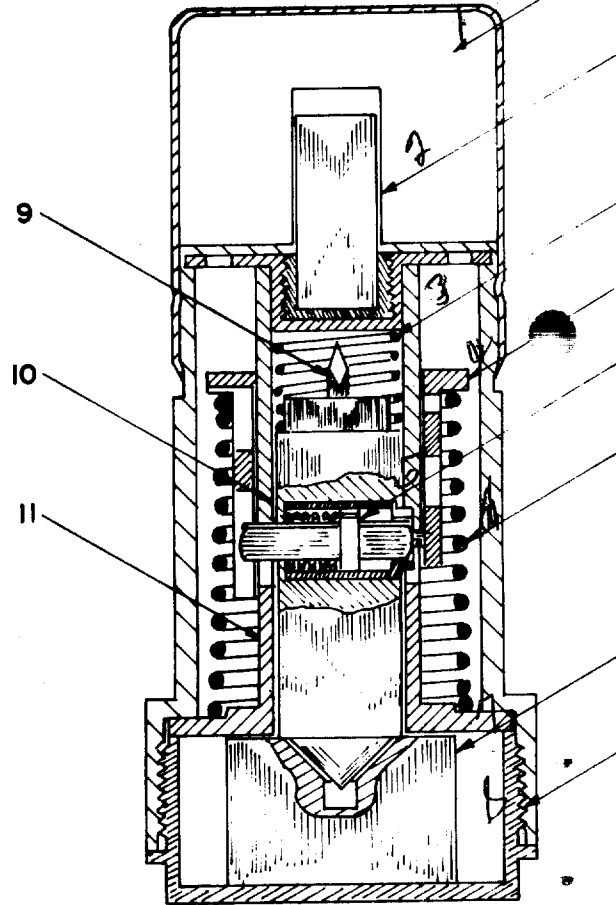
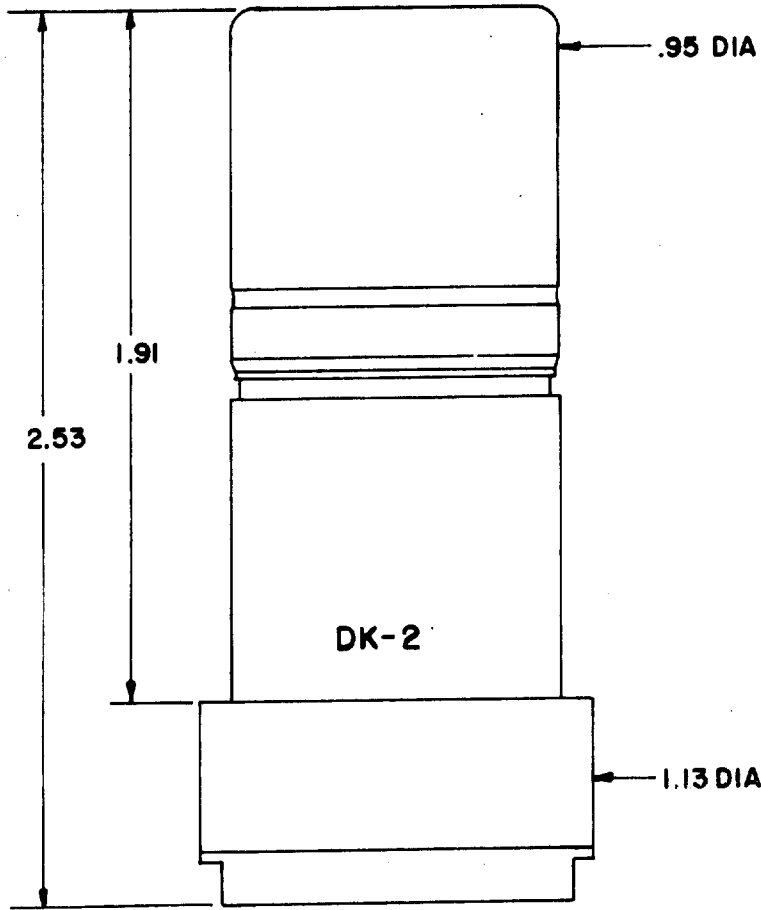

## SOVIET BASE DETONATING IMPACT FUZE DK-4

a. General: The Soviet DK-4 base detonating fuze is employed on the DG-2 grenade projectile. It is set-back armed, impact fired and incorporates a self-destruct feature. The DK-4 is considered an improved version of the DK-2. The purpose of the self-destruct feature is not understood, but a bonus dividend is an air burst capability.

The DK-4 fuze is made of aluminum, except for the springs, set-back sleeve, detents, firing pin and closing cap. The closing cap (18) threads onto the fuze body rather than threading internally, as in the DK-2. The booster cap (2) crimps into two circumferential grooves cut into the fuze body. The stab sensitive detonator (3) is held in the bottom of the fuze body by a threaded keep ring (5). A copper desensitizer disc (6) covers the detonator (3). A felt shock pad (2) is positioned in the bottom of the detonator cavity. Two waxpaper discs (4) separate the RPX wax booster charge from the fuze body.

The arming and firing mechanism of the DK-4 is housed in a flanged aluminum cylinder (9). The arming sleeve (10) and set-back spring (16) fit externally on the housing (9). The housing (9) contains a longitudinal channel that contains the flash pellet (21), safety spring (22) and the fixed firing pin (23). A lateral flash channel and gas escape port (13) connects the flash channel and the self-destruct delay element (15). The set-back sleeve locking detent (12) is spring loaded outward to lock the set-back sleeve to the rear upon set-back. A large external cut (27) leads from the flash pellet channel (24) around the side of the housing (9) to the pyrotechnic arming delay pellet (25). This pellet (25) is contained within a threaded housing (26). The pellet (25) prevents the set-back sleeve delay pin (11) from moving inward, powered by its spring, until a suitable arming delay has occurred, the pin (11) moves into the space originally occupied by the pyrotechnic pellet (25). This assembly prevents fuze arming unless suitable set-back and sustained acceleration has been applied to the fuzes. If acceleration ceases prior to arming delay pellet (25) burn out, the set-back sleeve (10) will move forward and be captured by the delay pin (11) and prevent the housing (9) from moving forward upon impact or self-destruct pellet functioning. This pin (11) acts as a positive shipping, handling and firing safety. The pin (11) in the extended position rests against the internal shoulder in the fuze body positively blocking all movement by the housing (9) until the arming delay pellet (25) has been consumed and the pin (11) has moved into the evacuated space. The pin (11) is notched near the end. The notch rides in a partial zig zag groove (28) cut into the set-back sleeve (10). This is a further arming delay feature.

### b. Characteristics:

Action ----- Instantaneous  
Loaded weight ----- 76 grams (0.16 lbs)  
Body material ----- Aluminum

c. Functioning: Upon firing, set-back causes the weighted primer (21) to move rearward against its spring (22). If set-back is of sufficient magnitude the primer (21) is impaled upon the fixed firing pin (23). The resulting flash travels through the flash channel (13) and ignites the self-destruct ignitor (14) starting the self-destruct delay element (15) burning. Flame also passes into the large cut (24) and ignites the pyrotechnic arming delay pellet (25). Simultaneously, the set-back sleeve (10) moves rearward, compressing its spring (16). When the mouth of the sleeve (10) clears the lock pin (12), the pin is forced outward by its spring locking the sleeve (10) to the rear. At this time the pyrotechnic delay pellet (25) burns out permitting the pin (11) to be forced into the evacuated cavity by its spring. The fuse is now armed. The housing (9) acting as an inertia weight is restrained only by the anti-creep spring (11).

Upon impact, the housing (9) moves forward permitting the firing pin (8) to pierce the stab-sensitive detonator (3) which initiates the booster and main charge. In the event the grenade misses the target the self-destruct element (15) burns through igniting the propelling charge (19). Forces from the charge (19) expand against the cap (18) forcing the housing (9) forward in the same manner as inertia forces will normally produce functioning.

d. Weapons and projectiles used with:

Soviet RPG-2 Grenade Launcher

PG-2 HEAT Grenade

SOVIET BASE DETONATING IMPACT FUZE DK-4

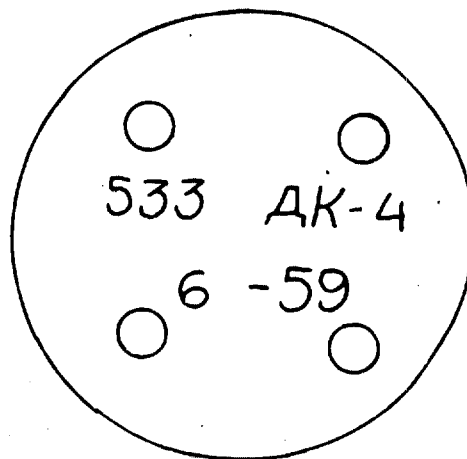
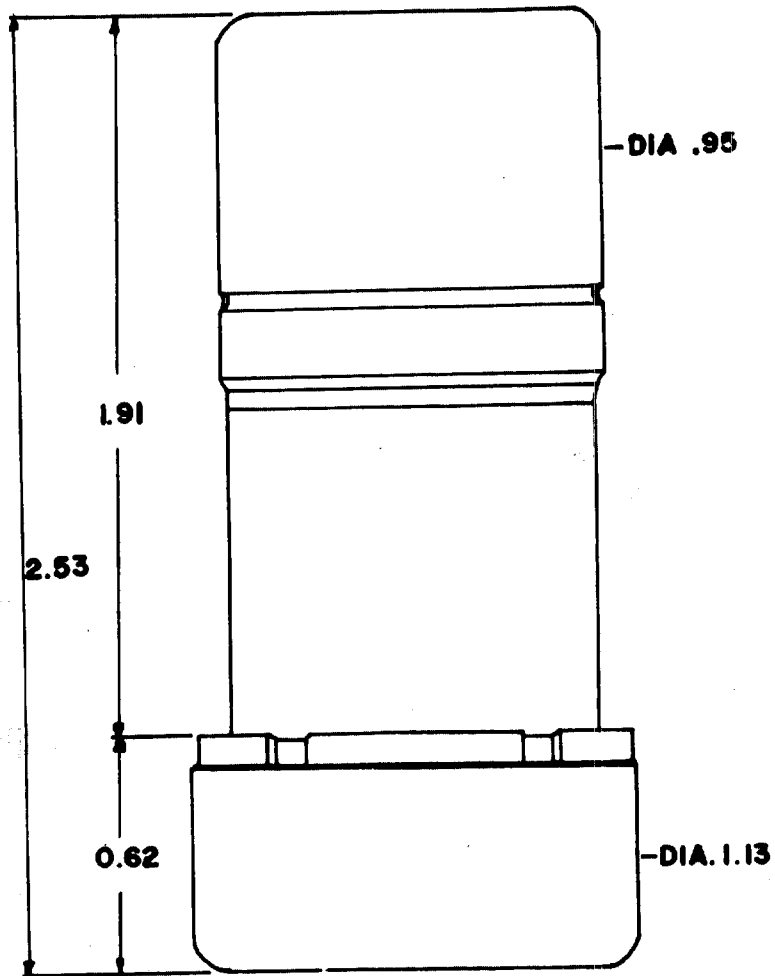

5-13

SOVIET BASE DETONATING IMPACT FUZE DK-4

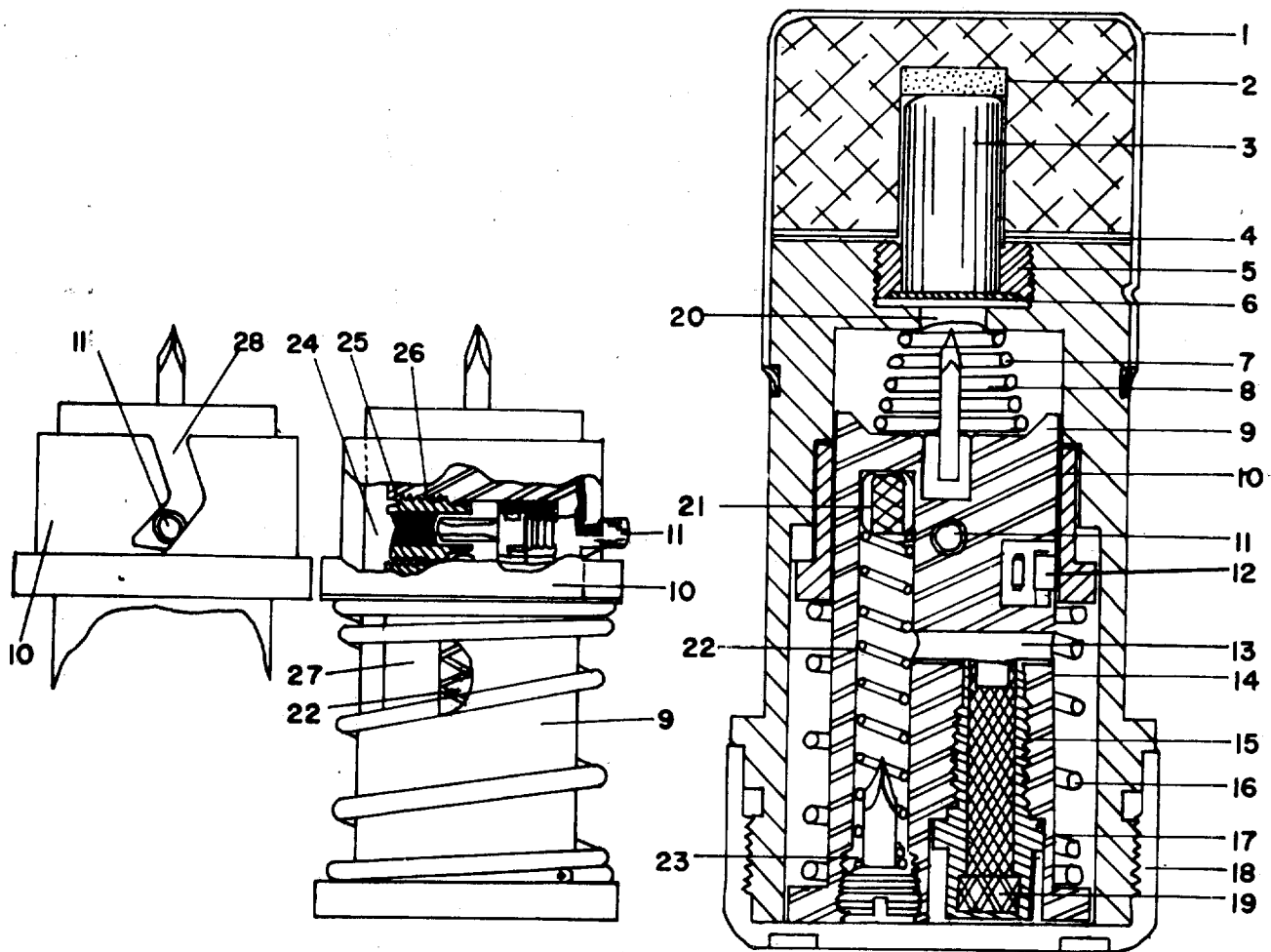

SOVIET BASE DETONATING IMPACT FUZE MODEL DP

The DP fuze is reportedly quite similar to the MD-5 fuze in functioning; however, in construction it differs from the latter by having larger external dimensions, increased weight of booster, and an anti-creep spring which, during the flight of the projectile, holds the primer carrier and primer and prevents them from striking the firing pin. The delay pellet is of pressed black powder, and delays functioning of the fuze until the projectile has penetrated the target. No illustration of this fuze is available, and there is no further information on it at this time.

5-25/5-16

a. General. The DR-5, because of manufacturing difficulties occasioned by its complex design, is no longer in production. No preparation of the fuze is required before loading.

b. Characteristics.

Action ----- short delay

Loaded weight ----- ?

Body material ----- ?

c. Functioning. Upon discharge, the tracer (9) is ignited by the burning propellant. The stirrup (6) sets back, overcoming the resistance of claws on the striker safety clamp (8). The latter then engages the striker (7). Simultaneously the bolt (13) sets back into a recess in the body of the fuze, locking the centrifugal shutter (1) until the shell has left the bore. It is necessary for the bolt (13) to immobilize the shutter because the only other shutter locking devices, two centrifugal segments (not shown), move free of the shutter while the shell is still traveling through the bore of the gun. When the shell leaves the bore, the centrifugal shutter is released and comes into the armed position, in which the detonator (12) lies opposite the relay charge (11). The striker (7) is prevented from moving during the flight of the shell by the anti-creep spring (5). Upon impact, the striker and the stirrup (6) move forward, driving the firing pin (15) into the primer (4). The flash from the primer passes to the powder delay element (14) by traveling along the lateral grooves of the set forward valve (3). On impact, inertia forces the set forward valve against the powder delay element; the gases generated by the combustion of the delay composition, however, pass through grooves on the front and sides of the set forward valve and escape from the powder delay element casing (2), thereby providing an even pressure and a normal rate of delay composition combustion. When the force of inertia exerted on the set forward valve decreases until its intensity is less than that of the pressure of the gasses on the valve, the latter is forced rearward by the gas pressure and closes the exit from the delay element casing. The gas pressure in the casing is therefore sharply increased and the delay element burns more rapidly. Its flame passes to the detonator (12) whose flash reaches the booster (10) by way of the relay charge (11). The force of inertia decreases when the shell has pierced the armor, and this insures the automatic regulation of the delay for the perforation of any given thickness of armor within the limits of the armor-piercing capacity of the given shell.

SOVIET BASE DETONATING IMPACT FUZE MODEL DR-5

d. Weapons and projectiles with which used.

Weapons	Projectiles
107-mm: corps guns M1910/30 & M1940 (M-60)	107-mm AP-T ----- BR-240
122-mm: corps guns M1931 & M1931/37 (A-19); tank gun M1943(D-25); SP gun M1944 (D-258)	122-mm AP-T BR-471 & ER-471B

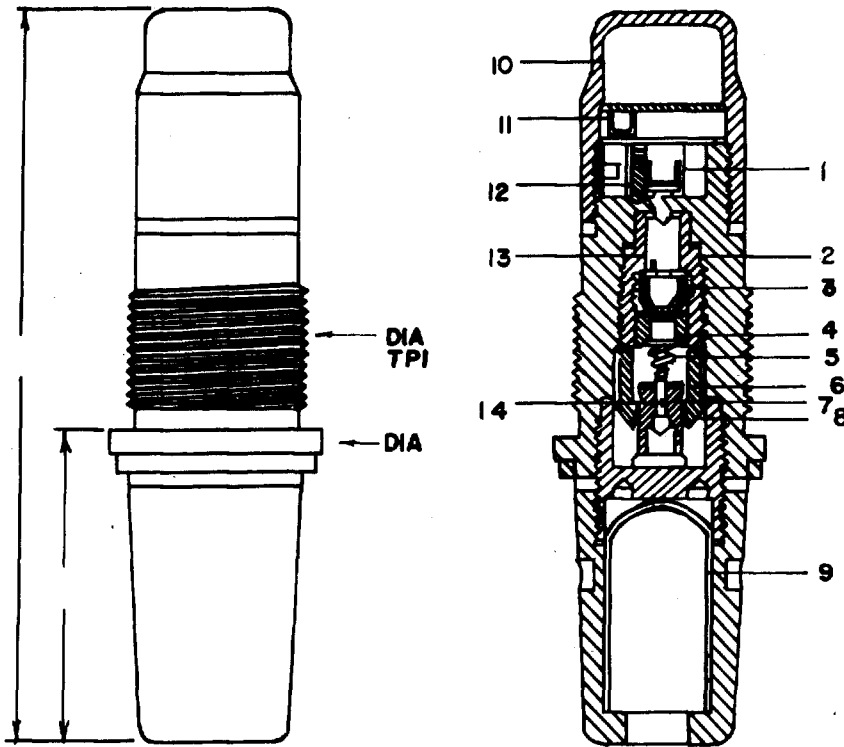

## SOVIET BASE DETONATING IMPACT FUZE MODEL KTD

a. General. The KTD (Kollektiv Trubochnikov, Donnyy: literally, "Group of fuze designers, Base detonating") fuze is the safety type and is used with a concrete-piercing projectile in both 122-mm and up to 280-mm caliber sizes. The fuze consists of a striking mechanism, safety mechanism, a setting selector, and a detonating device, all assembled in a sturdy steel body which is provided with a left-hand thread for attachment to the projectile. Settings for the fuze are as follows:

<u>Setting</u>	<u>Action</u>
"MK" -----	none (for transportation)
"3" -----	delay
"0" -----	nondelay

b. Characteristics.

Action ----- delay and nondelay

Loaded weight ----- ?

Body material ----- steel

c. Functioning. Upon firing, the arming rod (10) is set back by the force of inertia, compressing the arming rod spring (12), and comes into a position where the arming rod recess is opposite the striker check ball (11). The striker check ball drops into the recess in the arming rod and frees the striker (8). The anticreep spring (6) prevents the striker from moving forward against the primer (5). After the projectile leaves the bore of the weapon, the arming rod spring decompresses, forcing the arming rod into the extreme forward position, so that the recess in the rod is opposite the shutter check ball (4). Under centrifugal force, the shutter check ball drops into the recess in the rod and frees the centrifugal shutter (2). Centrifugal force moves the shutter in the guideway of the shutter housing (3) until it stops on the wall of the fuze body, thereby aligning the detonator (located in the shutter, but not shown) with the relay charge (9). Upon impact, inertia drives the striker forward and the firing pin (7) strikes the primer. If the fuze is set for nondelay action ("0"), the flash from the primer passes along a groove in the setting selector (13) and ignites the detonator. The detonator activates the relay charge, which initiates the booster (1), and the booster detonates the projectile. When the fuze is set for delay action ("3"), the groove in the setting selector is turned 180° away from the primer (5) and the direct passage from primer to detonator is closed. As a result, the flame from the primer is transmitted through a powder delay element (located in the shutter housing, beside the primer; not

SOVIET BASE DETONATING IMPACT FUZE MODEL KTD

shown in the drawing) to the detonator. The detonation wave then travels through the relay charge to the booster, just as in nondelay action.

d. Weapons and projectiles with which used.

Weapons	Projectiles
122-mm: corps guns M1931 & M1931/37 (A-19); tank gun M1943 (D-25) SP gun M1944 (D-25S)	122-mm CP ----- G-471
152-mm: guns M1910/34 and M1935; gun-howitzer M1937 (M-20); howitzers M1909/30 and M1938 (M10); tank howitzer M1938	152-mm CP ----- G-530; G-540; G-545
203-mm: howitzer M1931 (B-4)	203-mm CP ----- G-620
280-mm: mortar (howitzer) M1939 (BR-17)	280-mm CP ----- G-675

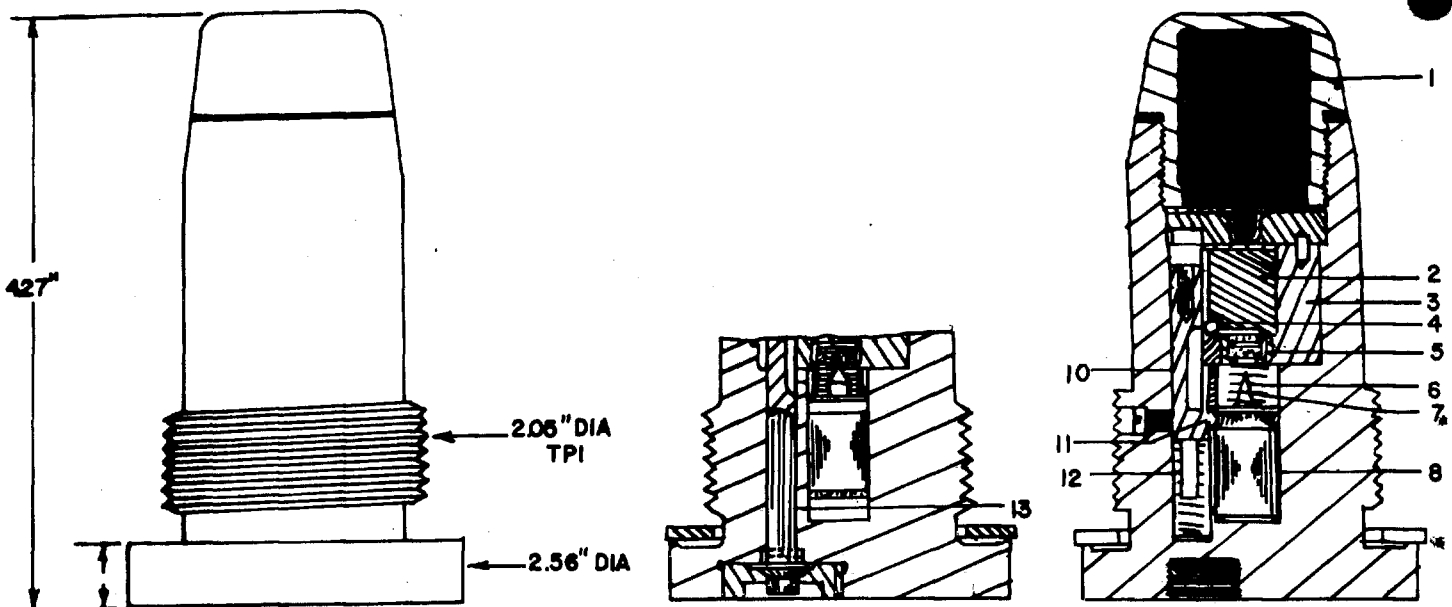

a. General.

- (1) The KTD-2 (Kollektiv Trubochnikov, Donnyy, 2-y Obrazets: literally, "Group of fuze designers, Base detonating, 2nd Model") is an improved model of the KTD fuze. However, the KTD has not been replaced altogether, because the KTD-2 cannot be used for low-velocity fire. For this reason the KTD-2 fuze is employed for priming 122-mm and 152-mm CP gun shells. The KTD-2 is almost identical in construction to the KTD, except as described below:
  - (a) The steel arming rod of the KTD has been replaced in the KTD-2 by a lighter, aluminum arming rod, in order to improve the arming qualities at high muzzle and angular velocities; because of the rod's lighter weight, there is less friction arising from the effect of centrifugal force, and the arming rod spring can easily move the arming rod forward.
  - (b) Increased sensitivity has been obtained by giving more weight to the striker (4); this was achieved by pressing a lead core (5) into its center.
  - (c) The sealing off of gases from the primer (3) by the setting selector (7) has been improved by the fact that the forward part of the selector has a circular section, the groove in the surface of the selector being replaced by an internal channel (6).
- (2) The KTD-2 fuze is not employed for fire at low velocities because of its poor arming qualities under such conditions. Because of the lightness of the arming rod, setback force at relatively low pressures is not sufficient to overcome the resistance of the arming rod spring.
- (3) Both the KTD and KTD-2 fuzes are completely safe, should spontaneous action of the primer (3) occur, at both non-delay and delayed action settings. If the fuze is set to delayed action ("3"), premature action is impossible since the primer's explosion would cause a bulge in the thin floor of the centrifugal shutter housing (2) that would jam the centrifugal shutter (1) in the safe position.

SOVIET BASE DETONATING IMPACT FUZE MODEL KTD-2

b. Characteristics.

Action ----- nondelay and delay

Loaded weight ----- ?

Body material ----- steel

c. Functioning. The KTD-2 is identical in functioning to the KTD.

d. Weapons and projectiles with which used.

Weapons	Projectiles
122-mm: corps guns M1931 and M1931/37 (A-19); tank gun M1943 (D-25); SP gun M1944 (D-258)	122-mm CP ----- G-471
152-mm: guns M1910/34 and M1935; gun-howitzer M1937 (ML-20)	152-mm CP ----- G-530; G-545

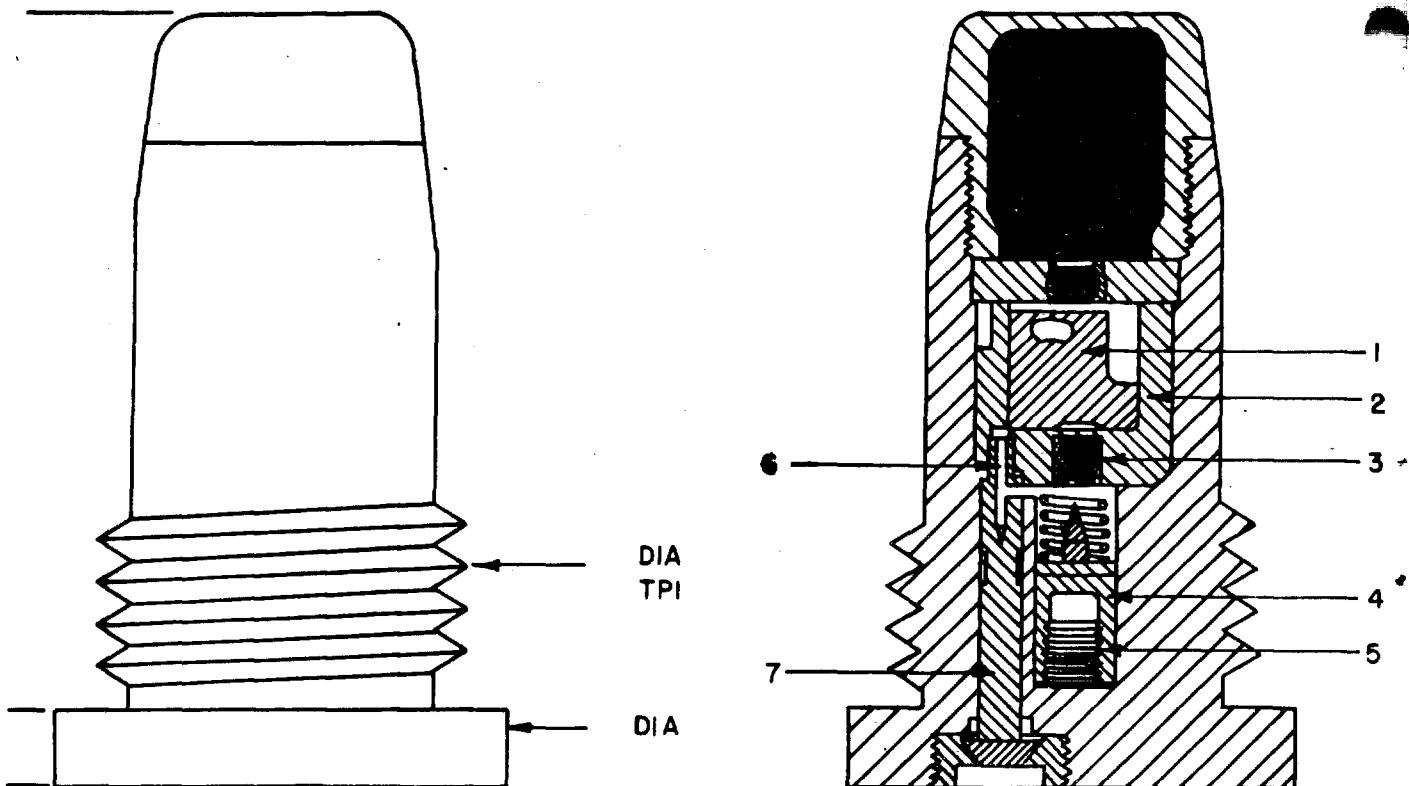

SOVIET BASE DETONATING IMPACT FUZE MODEL KTMF

A KTMF fuze is known to exist, but information on it is quite limited. Reportedly a modification of a French base detonating fuze, it is used with the "Morskoy" ("Naval") semi-armor-piercing high-explosive projectile in the 152-mm howitzers M1938 (M-10) and M1943 (D-1). Its overall length is 4.60 inches, its maximum diameter 2.70 inches, and its major thread diameter 2.15 inches.

SOVIET BASE DETONATING IMPACT FUZE MODEL MD-1, MD-2, MD-3 & MD-4

Thses are earlier models in the series of MD (Malokalibernyy, Donnyy: small caliber, base detonating) fuzes. Although there is little available information on them, they are thought to be essentially very similar, and are presumably obsolete. The MD-2 is illustrated below.

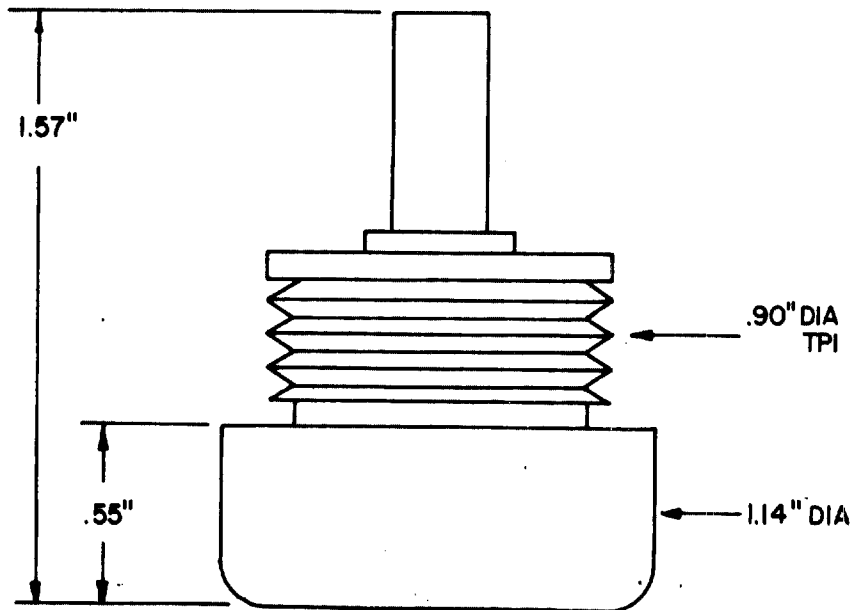

5-23/5-24

SOVIET BASE DETONATING IMPACT FUZE MODEL MD-5

a. General. The MD-5 (Malokalibernyy, Donnyy, 5-y Obrazets: small caliber, base detonating, 5th Model) is the fifth model of the MD series of Soviet fuzes used with armor-piercing high-explosive projectiles. Previous models of this series are numbered MD-1 through MD-4, and known later models are the MD-6, MD-7, MD-8, and MD-10. The MD-5 is of conventional design, and incorporates a primer, a delay pellet, and a detonator in the explosive train. It is equipped with a removable tracer. An "initiator," which is inserted separately in the projectile, is used to initiate the main charge. This initiator is kept separate from the fuze and projectile, and is inserted in the fuze well just prior to use. The Soviet safety classification of the MD-5 is "unsecured."

b. Characteristics.

Action ----- short delay  
Loaded weight ----- 110 gm. (0.242 lb.)  
Body material ----- steel

c. Functioning. Upon firing, the tracer mixture (8) is ignited by the propellant gases. Flame from the tracer is prevented from entering the fuze body and causing premature detonation by the solid end of the fuze body. At the same time, the stirrup (5) sets back over the primer carrier (7) and clamps itself to the carrier. This action brings the primer (6) flush with the forward end of the stirrup in a position to impinge upon the firing pin (4) at impact. Upon impact, the stirrup and primer carrier set forward, driving the primer against the firing pin. The primer ignites and emits a jet of flame through holes drilled in the firing pin holder, thence through a hole in the base plug (2) to the black powder delay pellet (3). The pellet burns sufficiently long to permit the projectile to penetrate the armor, and then activates the detonator (1), which in turn detonates the explosive filler of the projectile. CAUTION: In the armed state, this fuze is extremely sensitive and a light blow upon the nose of the projectile may detonate it.

SOVIET BASE DETONATING IMPACT FUZE MODEL MD-5

d. Weapons and projectiles with which used.

Weapons	Projectiles
45-mm: antitank guns M1932, M1937, and M1942; tank guns M1932, and M1934	45-mm AP-T ----- BR-240; B-240
57-mm: antitank guns M1941 and M1943 (ZIS-2)	57-mm AP-T ----- BR-271
76-mm: divisional M1902/30, M1933, M1936 (F-22), M1939 (USV), & M1942 (ZIS-3); tank guns M1938/39 (L-11) and M1939 (F-32); regimental guns (howitzers) M1927 and M1943	76-mm AP-T --- BR-350; BR-350A; BR-361

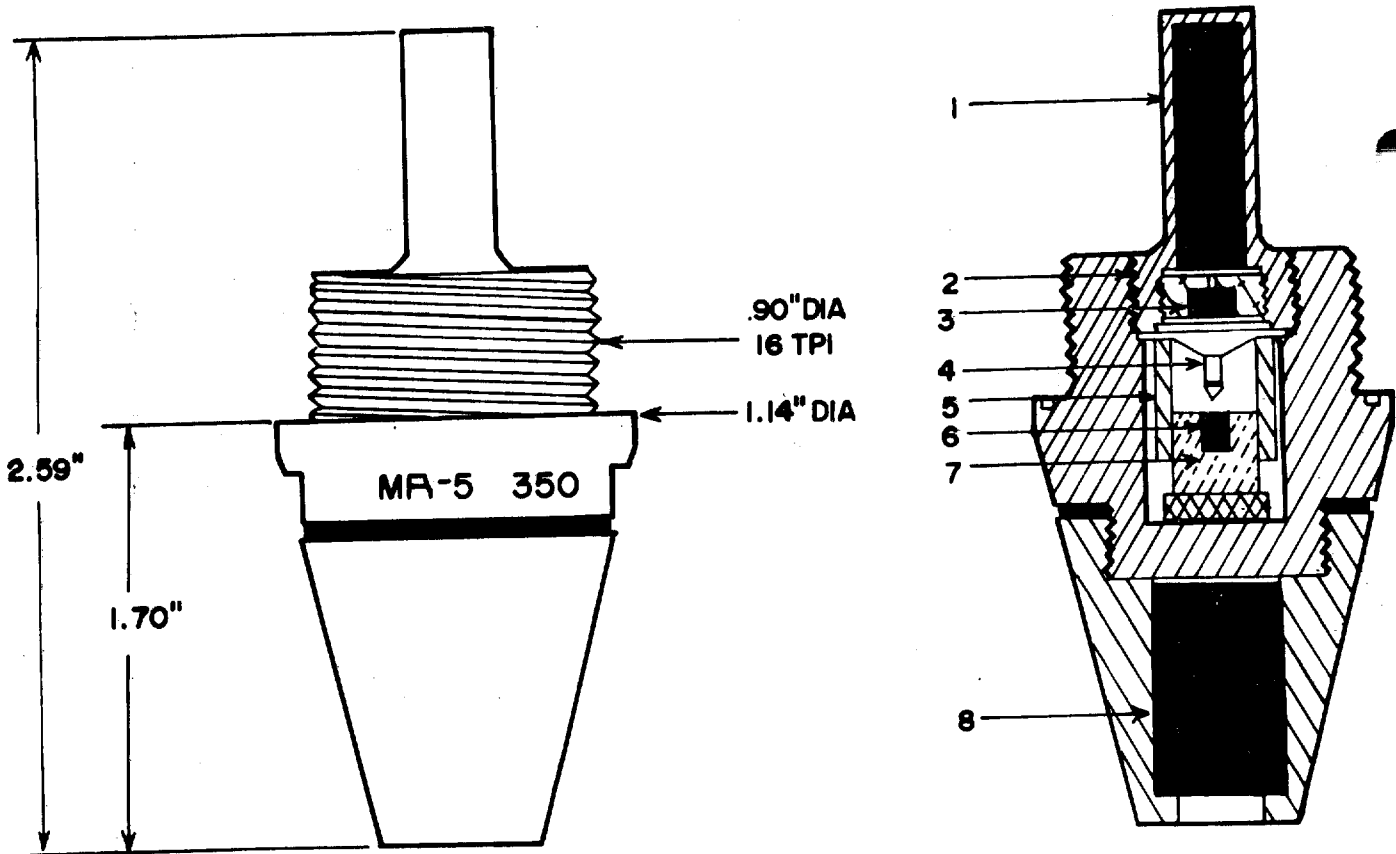

SOVIET BASE DETONATING IMPACT FUZE MODEL MD-6

This is the sixth model of the MD series of Soviet fuzes used with armor-piercing high-explosive projectiles. Previous models of this series are numbered MD-1 through MD-5, and known later models are MD-7, MD-8, and MD-10. The MD-6 differs from the MD-5 only in thread size. Accordingly, it cannot be used in the same projectiles as the MD-5. The designs of the two fuzes are otherwise identical. The MD-6 is interchangeable with the MD-8 and MD-10 fuzes. The main drawback of the MD-6 is the constant delay. This time cannot be varied according to the thickness and hardness of the target armor plate. The result is that the fuze action is not always effective against different armor plate thicknesses. The automatic retarding feature of the fuze models DR-5, MD-7, and MD-8 has partly corrected this fault.

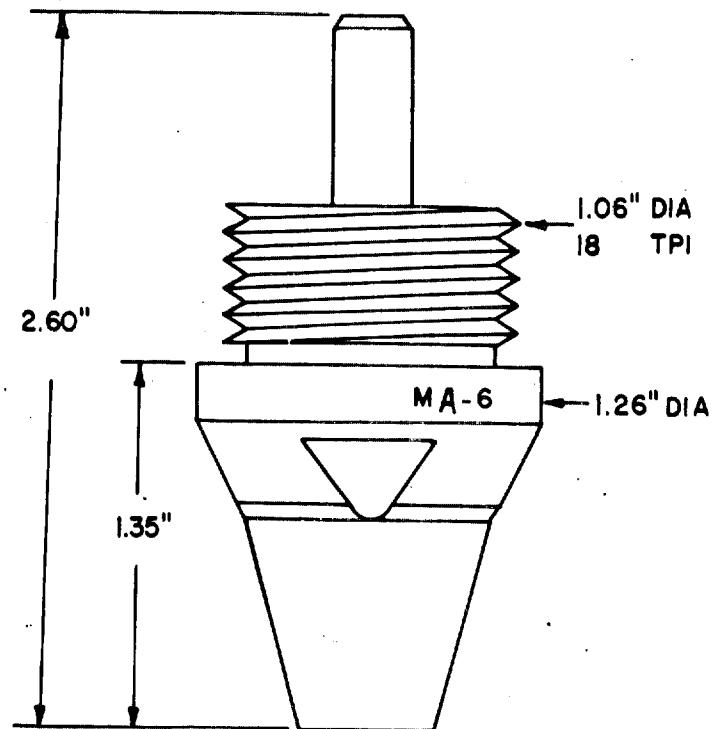

5-27/5-28

a. General. The MD-7 (Malokalibernyy, Donnyy, 7-y Obrazets: small caliber, base detonating, 7th model) is similar to the MD-5 in internal structure, but differs from it by having an anticreep spring, a tin foil safety disk, and an automatically regulated delay. The anticreep spring and the tin foil safety disk on the primer insure a high degree of safety from premature bursts of the shell while in the tube of the weapon, and the Soviets classify the MD-7 as "safe". There are further differences in the shape of the tracer nut. This fuze is used with armor-piercing tracer projectiles.

b. Characteristics.

Action ----- delay  
 Loaded weight ----- ?  
 Body material ----- ?

c. Functioning. Upon firing, the burning propellant ignites the tracer (10) and setback causes stirrup (7) to move rearward, overriding the primer carrier (9), which is then held in the rearward position only by the anticreep spring (6). Upon impact with a target, the primer (8) and primer carrier move forward against the firing pin (5). The flash from the primer passes through a hole drilled in the firing pin holder and ignites the delay composition (3). The set forward valve (4) moves forward, because of inertia, and remains in the forward position until the projectile has penetrated the armor, at which time the gases produced by the delay pellet force the valve rearward, thus sealing off the gases. This causes a rapid increase in pressure which in turn causes the delay element to burn almost instantaneously. When the delay element has burned through, it actuates the detonator (2), which detonates the booster (1).

d. Weapons and projectiles with which used.

Weapons	Projectiles
57-mm: antitank gun M1941 and M1943 (ZIS-2)	57-mm AP-T ----- BR-270; BR-271
152-mm: gun M1910/34; gun-howitzer M1937 (ML-20)	152-mm AP-T ----- BR-540

SOVIET BASE DETONATING IMPACT FUZE MD-7

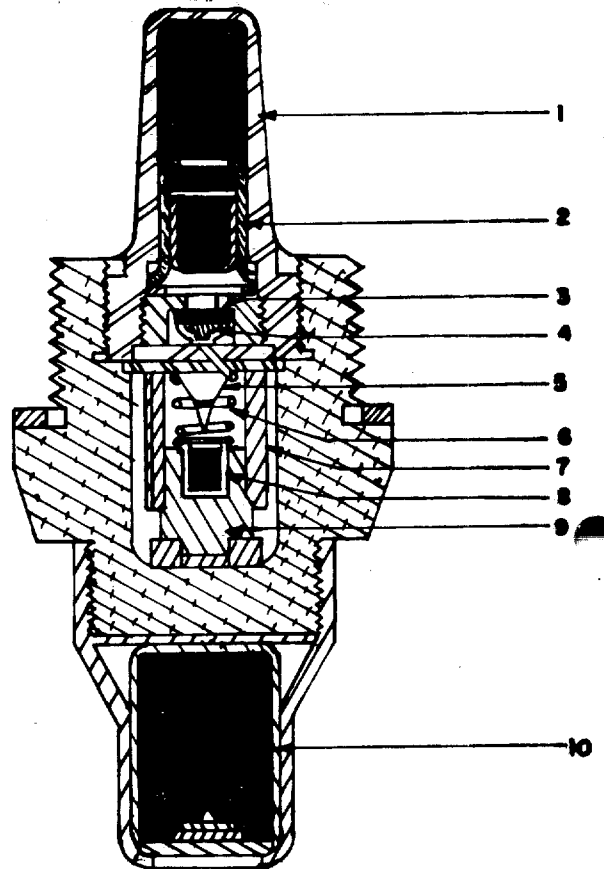
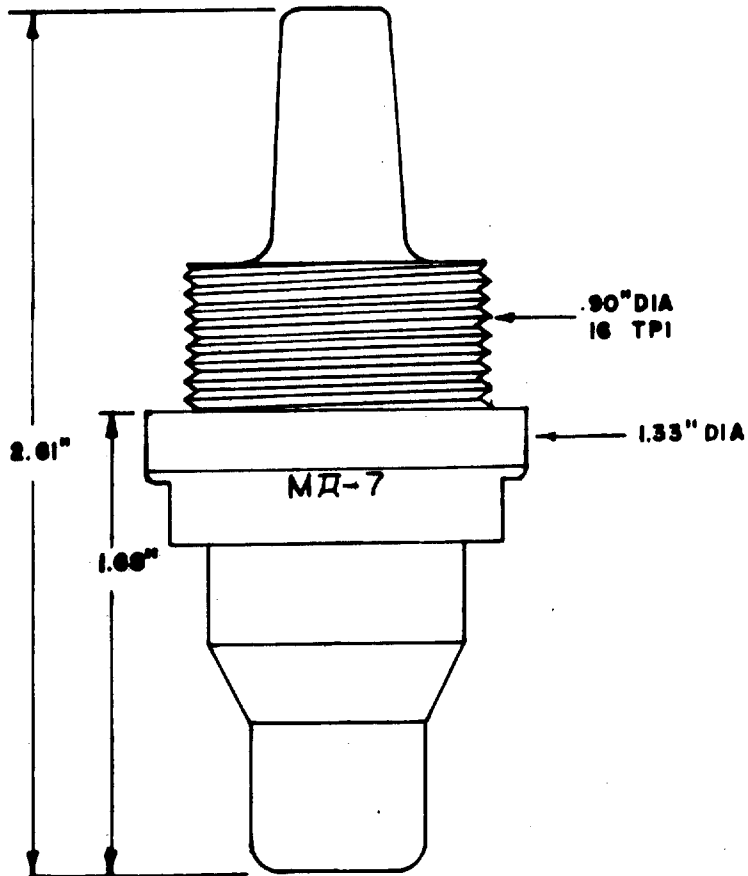

SOVIET BASE DETONATING IMPACT FUZE MD-8

a. General. The Soviet MD-8, base detonating, impact fuze is the eighth model in the MD series employed with armor-piercing high explosive projectiles. The MD-8 is interchangeable with the MD-6 and MD-10 fuzes, and is used in 76-mm, 85-mm, 100-mm, and 122-mm AP projectiles. The MD-8 is of conventional design, employing a primer, delay pellet, detonator and booster type explosive train. It is equipped with removeable tracer assembly and can be encountered with or without the tracer. The MD-8 has been designed with a delay pellet to permit greater target penetration prior to projectile detonation.

b. Characteristics.

Action ----- delay  
Loaded weight ----- ?  
Body material ----- steel.

c. Functioning. Upon firing, setback forces the split safety sleeve (7) off the shoulder of the primer carrier (6) and down onto the lead cushion ring (8). The moveable primer carrier is then separated from the firing pin (4) only by the anti-creep spring (5). Upon impact with the target, inertia causes the primer carrier to move forward impaling the primer onto the firing pin (4). Flame from the primer passes through a flash channel at the base of the firing pin igniting the delay pellet (3). Upon burnout, the delay pellet flashes into the detonator (2) which initiates the booster and main charge.

d. Weapons and projectiles with which used.

Weapons

Projectiles

Various types of ammunition to fit 76-mm, 85-mm, 100-mm, and 122-mm guns, too numerous to list here.

SOVIET BASE DETONATING IMPACT FUZE MD-8

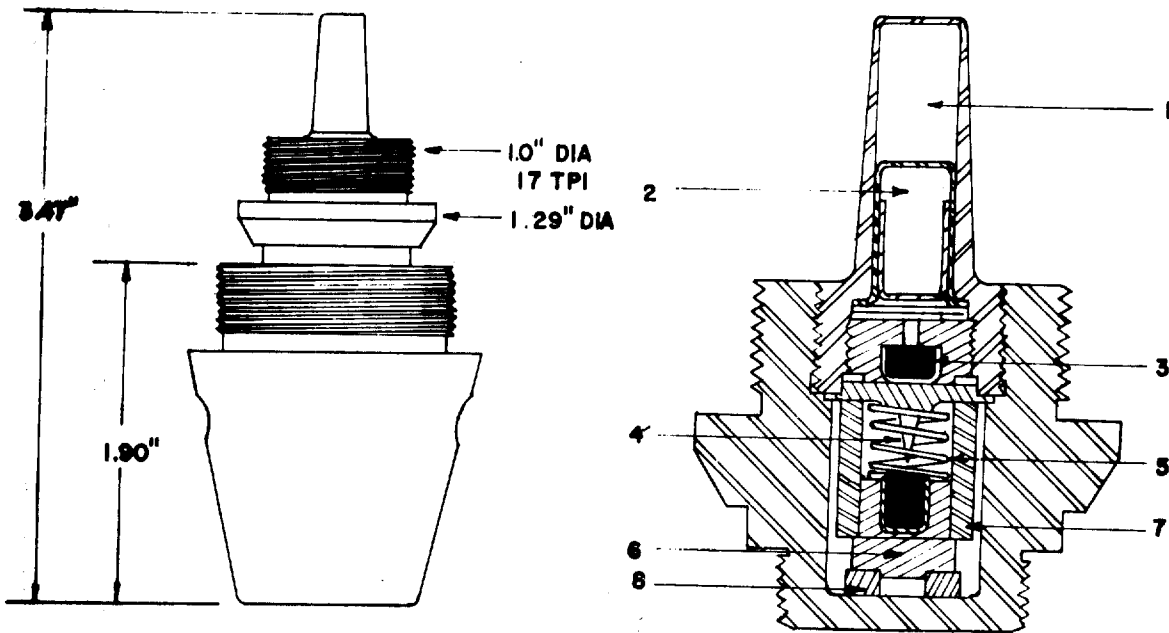

SOVIET BASE DETONATING IMPACT FUZE MODEL MD-10

a. General. The MD-10 is the tenth model of the MD series of Soviet fuzes used with armor-piercing high-explosive projectiles. Previous known models of this series are numbered MD-1 through MD-8. The MD-10 is of conventional design and incorporates a primer, a delay, and a detonator. It is equipped with a removable tracer. The simplicity of this fuze, in contrast with more complicated self-regulating delays employed in earlier models of the series, tends to indicate that the self-regulating delay, although good in theory, has proven impractical. The MD-10 has two safety features: the stirrup (6) which rests on the shoulder of the primer carrier (7), preventing it from moving forward; and the anticreep spring (5), which also tends to hold the primer carrier in the rearward position. This fuze is interchangeable with the MD-6 and MD-8.

b. Characteristics.

Action ----- short delay

Loaded weight ----- ?

Body material ----- steel

c. Functioning. Upon firing, the tracer mixture (8) is ignited by the propellant gases. Flame from the tracer is prevented from entering the fuze body and causing premature detonation by the solid end of the fuze body. At the same time, the stirrup (6) sets back over the primer carrier (7) and clamps itself to the primer carrier. The fuze is then armed and the primer carrier is prevented from carrying the primer (10) forward only by the resistance of the anticreep spring (5). Upon impact, inertia causes the primer carrier to overcome the anticreep spring and move forward, driving the primer into the firing pin (4). The flash from the primer passes through the flash channel (9) in the firing pin and ignites the delay element (3). The delay element burns through and actuates the detonator (2), which initiates the booster (1).

SOVIET BASE DETONATING IMPACT FUZE MODEL MD-10

150

d. Weapons and projectiles with which used.

501

Weapons	Projectiles
76-mm: divisional guns M1902/30, M1933 M1936(F-22), M1939(USV), and M1942(ZIS-3); tank guns M1938-/39(L-11) and M1939(F-32)	76-mm AP-T ----- BR-350B
85-mm: antiaircraft gun M1939; tank guns M1943(D-5T85) & M1944 (ZIS-S53); SP gun M1943(D5-S85)	85-mm AP-T BR-365K; BR-365
122-mm: corps guns M1931 & M1931/37 (A-19); tank gun M1943 (D-25); SP guns M1943(D-25S) & M1944 (A-19S)	122-mm AP-T ----- BR-471B

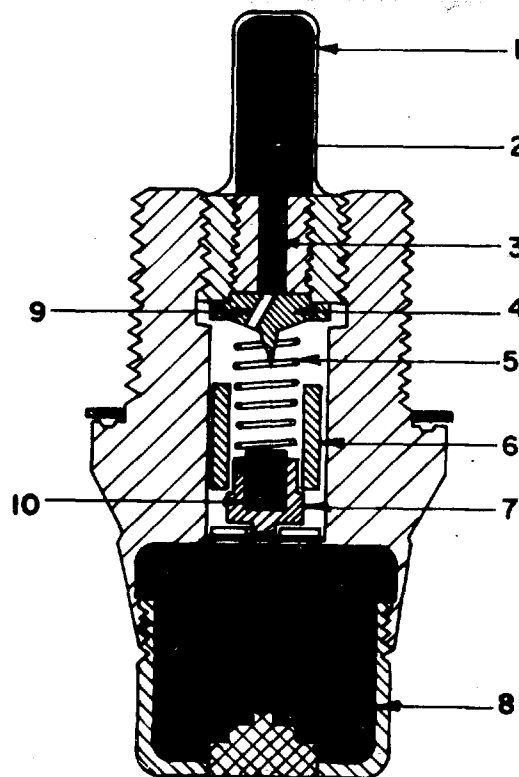
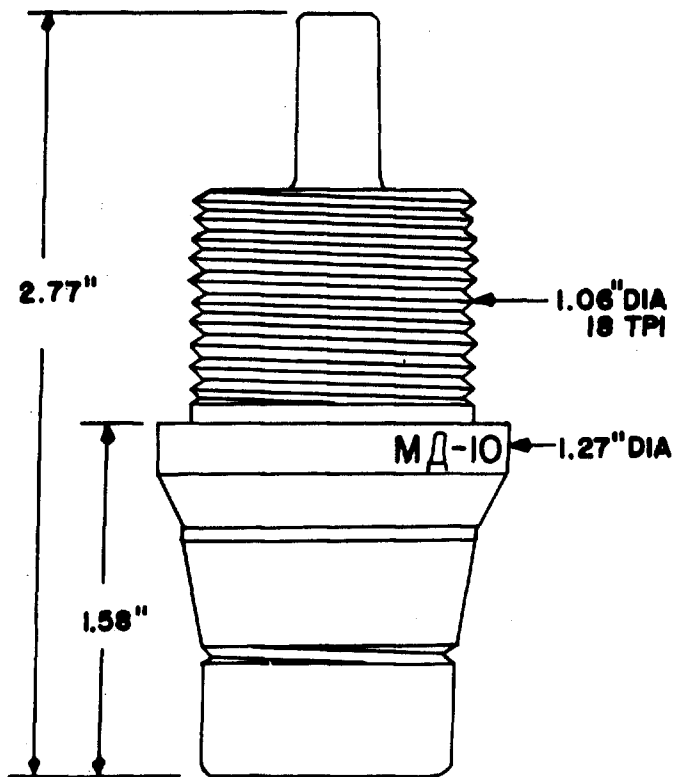

SOVIET BASE DETONATING IMPACT FUZE MODEL MD-76

An MD-76 fuze is reported to exist, and is said to be a conventional base detonating type designed for use with 76-mm armor-piercing projectiles. No further information on this fuze is available at this time.

5-35/536

SOVIET BASE DETONATING IMPACT FUZE MR-Z

a. General. The Soviet MR-Z base detonating impact fuze is a set-back armed, boresafe fuze that may incorporate a delay pellet. The fuze has a steel body and employs large pitch, modified-buttress type threads. It is employed on large caliber concrete-piercing and armor-piercing projectile.

b. Characteristics.

Action ----- delay  
Loaded weight ----- ? grams (? lbs)  
Body material ----- Steel

c. Functioning. The fuze diagram depicts the fuze in the armed condition. Prior to being fired, the arming sleeve (4) is in the forward position, resting against the primer housing (2). This effectively masks the firing pin, preventing contact with the primer. Upon being fired, set-back causes the arming sleeve (4) to move to the rear, coming the legs of the stirrup (5) inward so that they can expand into the internal groove cut into the arming sleeve (4), locking the sleeve to the moveable firing pin (6). The firing pin is held away from the primer by the anti-creep spring (3). When the projectile is fired, a lock pin (not shown) moves to the rear permitting the rotor to turn by centrifugal force. When the flash channel is opened between the primer and the detonator, a spring locks the rotor in position. Upon impact, inertia causes the firing pin with the added weight of the arming sleeve (4), to move forward, piercing the stab sensitive primer and initiating the explosive train.

d. Weapons and projectiles with which used.

Weapons	Projectiles
130-mm: Field gun M1946	130-mm APC ---- BR-482, BR-482B
	130-mm CP ----- G-482

SOVIET BASE DETONATING IMPACT FUZE MR-2

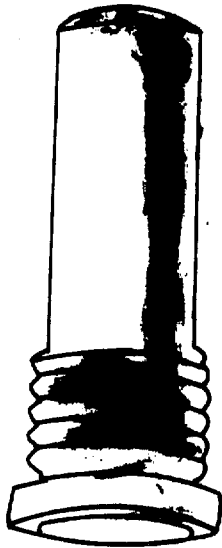

MR-2

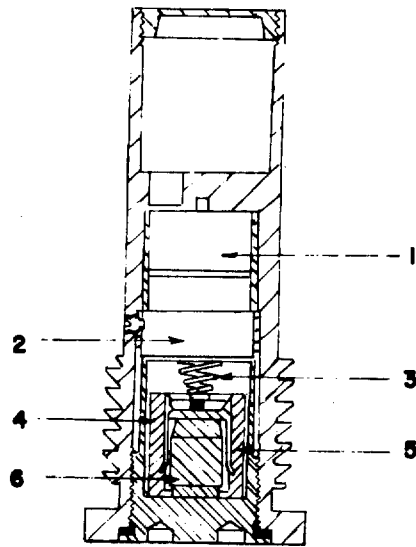

SOVIET PIEZO-ELECTRIC, POINT INITIATING, BASE DETONATING, IMPACT FUZE VP-7

a. General. The Soviet VP-7 fuze is a piezo-electric fuze incorporating an impact nose element containing twin crystals and a base detonating element containing all mechanical and electrical arming and firing components. The fuze employs a pyrotechnic delay, self-destruct element (8). Delayed arming is accomplished through a pyrotechnic delay (23) that is initiated by set-back. The fuze is both bore safe and detonator safe. The electrical detonator (29) is contained in a vertical sliding detonator carrier. An electrical shorting contact (27) is mounted in the slider beneath the detonator. This contact provides a dead short across the detonator bridge wire until the slider is in the armed position.

The VP-7 fuze housing is milled from an aluminum cylinder. The vertical slot contains the slide. One leg of the housing contains the set-back primer (17) which initiates the self-destruct element (8) and the arming delay element (23). The self-destruct delay (8) and detonator (7) are contained in the same leg. A flash channel (20) connects the flash pellet cavity with the self-destruct cavity. Another flash channel (21) connects with an external milled groove (22) so that the delay arming pellet can be ignited. Ignition of the self-destruct delay train is accomplished by flame passing through the four holes (9) in the self-destruct housing. The delay arming pellet (32) blocks the retraction of the locking pin (26), which holds the detonator slides in the safe position. When the pellet (32) is consumed the pin (26) is forced into the evacuated cavity by the caming surface on the slider. The slide is further held locked by a set-back pin (24) that holds locking ball (11) in a groove in the slide. The ball (12) prevents the pin (24) from moving too far forward. The slide is powered downward by two springs that rest in the twin cavities (13). The cover (28) compresses the springs. A blast channel (6) leads from the self-destruct detonator (7) to the electric detonator (29) in the slide. When the self-destruct delay (8) burns out the detonator (7) is initiated. The detonating wave passes through the channel (6) and sympathetically detonates the electric detonator, which initiates the explosive train. A steel block (5) protects the booster lead (3) should the electric detonator premature with the slide in the unarmed position.

The piezo-electric nose element employs the warhead body as one electrical lead and an inner cone as the other. Contact is made with the electric detonator by the pin (1) and the integral stud on the closing cap (10). The contact (29) completes the circuit when the slide is armed.

b. Characteristics.

Action ----- Piezo-electric instantaneous  
Loaded weight ----- Not applicable. internal, non-removable  
Body material ----- Aluminum and plastic

c. Functioning. Upon firing set-back causes the weighted flash primer (17) to move rearward compressing its spring (18) and impales itself on the fixed firing pin (19). The resulting flame travels up the flash channel (20), ignites the self-destruct delay element (8) through the holes (9) in the delay housing and continues on up the flash channel (21) where the flame spreads in the groove (22) and ignites the arming delay pellet (23) that begins to burn.

Simultaneously the set-back pin (24) moves rearward against its spring (14) depositing the ball (12) in the fuze cavity (15). The slight rotation of the rocket plus the cam surface on the slider causes the slide lock ball (11) to move inward, unlocking one side of the slider. As the arming delay pellet (23) is consumed the slider moves downward under action of the twin compressed springs (13), camming the lock pin (26) into the evacuated pellet cavity (23). When completely unlocked the slide moves downward, aligning the electric detonator (29) with the booster lead (3) and further aligning the self-destruct blast cavity (6) with the hole in the slide leading to the detonator (29). With the downward movement of the slider the shorting pin (27) is disconnected from the stud on the closing cap and the electric detonator contact (29) moves with the stud. The fuze is now mechanically and electrically armed.

Upon impact with a target the twin piezo-electric crystals in the nose element are stressed. This generates a pulse of current that travels through the inner and outer cones of the ogive, through the pin (1), through the fuze housing, onto the bridge wire of the electric detonator. The detonator is initiated, which functions the explosive train.

If the rocket does not impact with a target. The self-destruct delay (8) burns into the self-destruct detonator (7) which flashes through the channel (6) to detonate the electric detonator, initiating the rocket explosive train in the normal manner.

d. Weapons and projectiles used with.

Weapons	Projectiles
Soviet Anti-Tank Rocket Launcher RPG-7	Anti-Tank rocket PG-7
Rumanian Anti-Tank Rocket Launcher RPG-7	

SOVIET PIEZO-ELECTRIC POINT INITIATING, BASE DETONATING, IMPACT FUZE VP-7

5-41

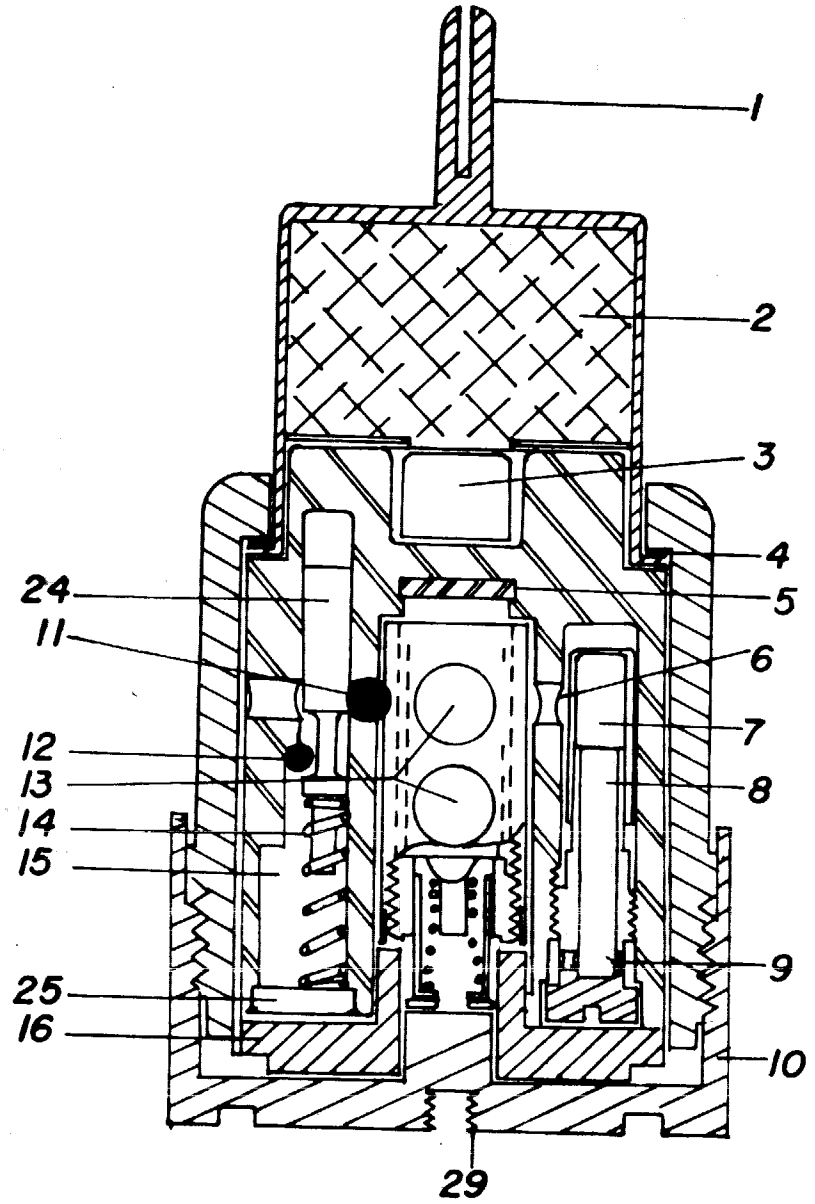
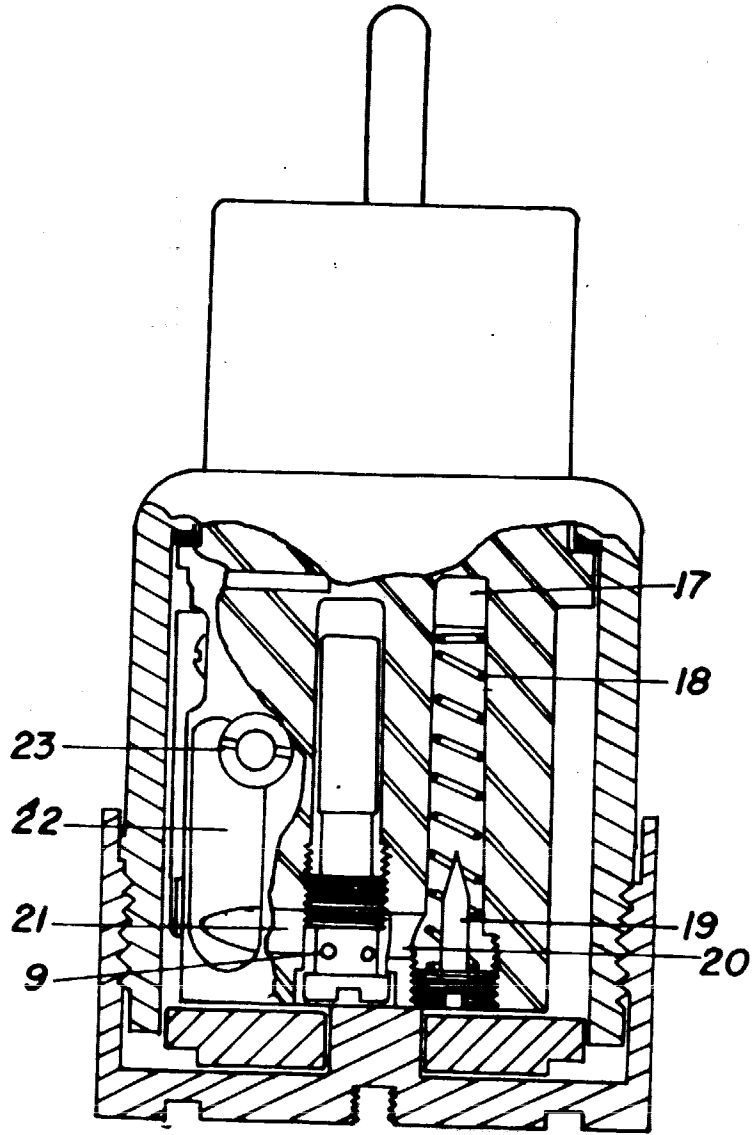

**SOVIET PIEZO-ELECTRIC POINT INITIATING, BASE DETONATING, IMPACT FUZE VP-7**

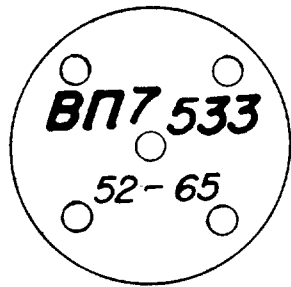

**SOVIET**

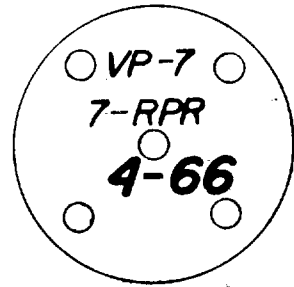

**RUMANIAN**

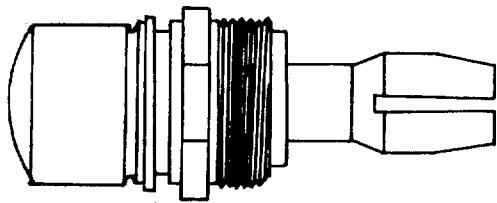
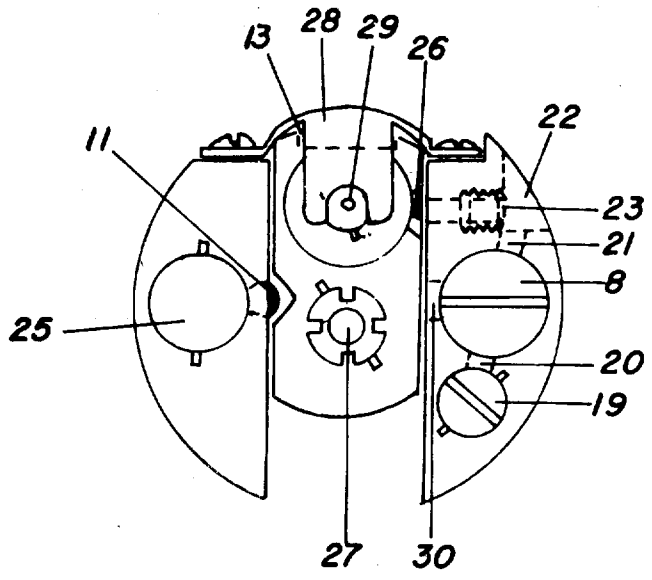

**PIEZO ELECTRIC NOSE ELEMENT**

SOVIET BASE DETONATING IMPACT FUZE MODEL 5DM

a. General. Information on the 5DM is based entirely on documentary sources, and is extremely limited.

b. Characteristics.

Action ----- delay  
Loaded weight ----- ?  
Body material ----- ?

c. Functioning. Apparently, upon firing, setback causes the stirrup (8) to shear the safety pin (10), move rearward, and override the striker clip (9), an action which secures the stirrup to the striker (12). Then only the anticreep spring (7) prevents forward movement of the striker. Upon impact with the target, inertia causes the striker to overcome the anticreep spring and drive the firing pin (11) forward into the primer (6). The primer emits a jet of flame through a flash channel, igniting the delay element (5). When the delay burns through, it ignites the powder charge (4) which forces the firing pin (3) into the detonator (2). The detonator activates the booster (1), which detonates the main charge.

d. Weapons and projectiles with which used. Information on this subject not available.

SOVIET BASE DETONATING IMPACT FUZE MODEL 5DM

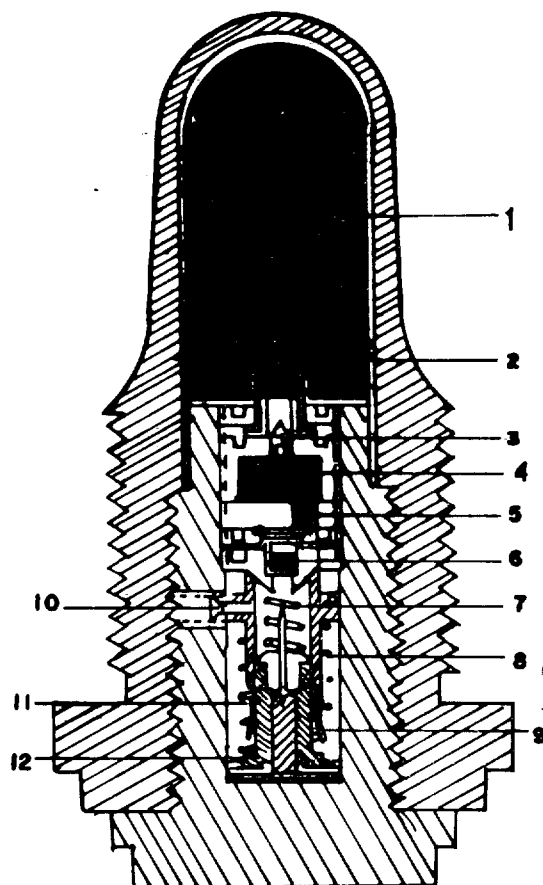
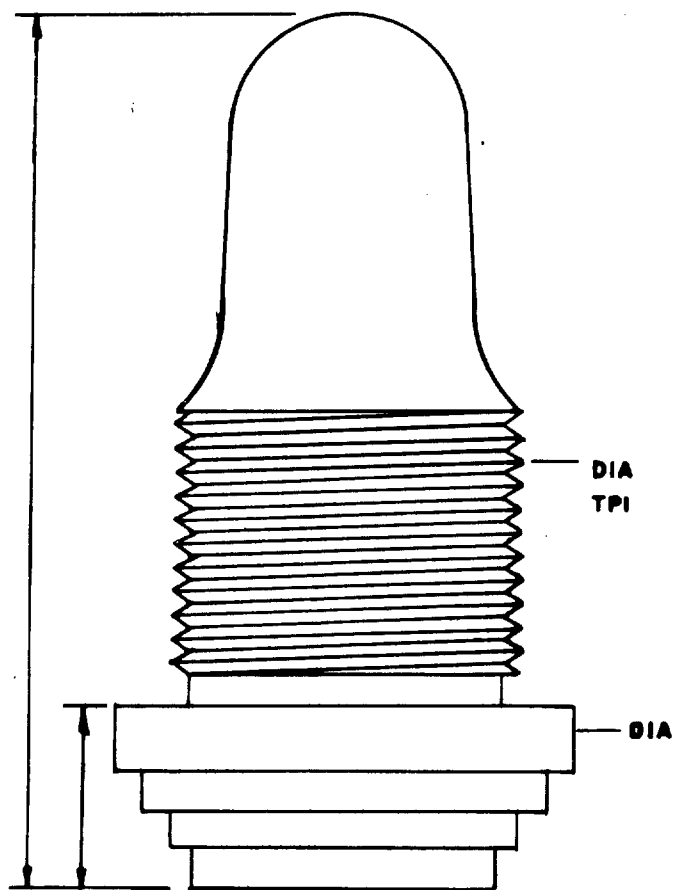

SOVIET BASE DETONATING IMPACT FUZE MODEL 5DT-2

a. General. The 5DT-2 is an inefficient fuze because of the overcomplexity of its detonating device and the poor gas obturation of its closing cap. This fuze is not boresafe. Settings for the 5DT-2 are as follows:

<u>Setting</u>	<u>Action</u>
"II" -----	none (for transportation)
"3" -----	delay
"M" -----	likelihood of premature bursts in the bore; this setting must not be used

Before loading the weapon, the fuze must in all instances be set for delay action!

b. Characteristics.

Action -----	delay
Loaded weight -----	?
Body material -----	?

c. Functioning. On firing, the stirrup (12) sets back, overcomes the resistance of the stirrup retaining spring (14), pushes the locking ball (8) into the socket of the setting selector (10), and locks itself to the stirrup retaining spring. On impact with the target, inertia causes the striker (9) to overcome the anticreep spring (7) and to drive the impact firing pin (13) forward into the primer (6). The flash from the primer passes through the powder delay pellet (11) to the powder magazine (5). Under the pressure of the gasses produced by the burning of the powder magazine, the detonator firing pin (4) breaks through the brass disk (3) and pierces the detonator (2). The resulting explosion then detonates the booster (1).

SOVIET BASE DETONATING IMPACT FUZE MODEL 5DT-2

d. Weapons and projectiles with which used.

Weapons	Projectiles
203-mm: howitzer M1931 (B-4)	203-mm HE ----- F-620
280-mm: Mortar (howitzer) M1939 (BR-5)	280-mm HE ----- ?
305-mm: howitzer M1915	305-mm HE ----- ?

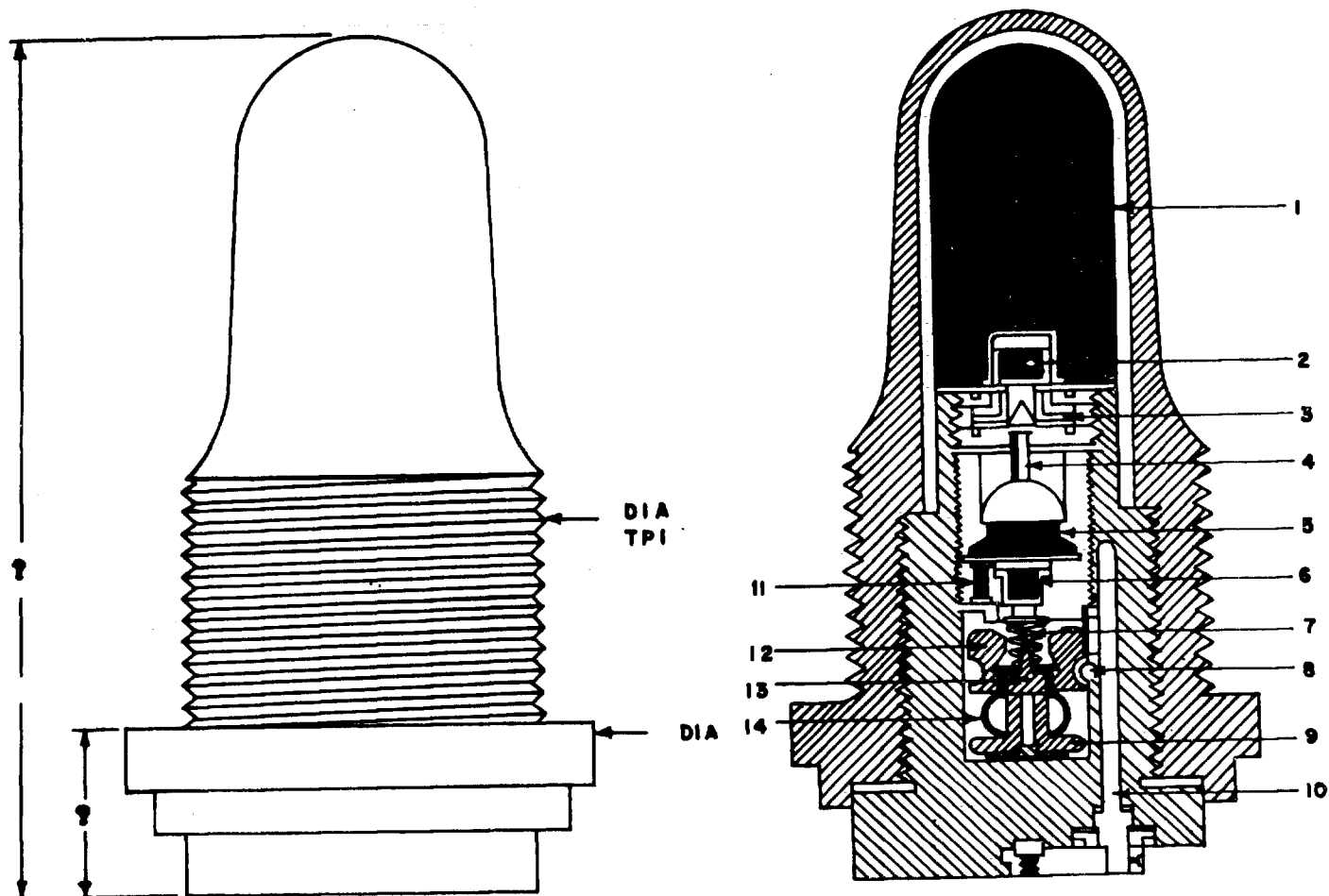

SOVIET BASE DETONATING IMPACT FUZE MODEL 7DT

a. General. Information on the 7DT is limited and unverified. The fuze appears to be a conventional base detonating type and is reportedly used in medium and large-caliber naval and coastal artillery in both high-explosive and armor-piercing projectiles.

b. Characteristics.

Action ----- nondelay

Loaded weight ----- ?

Body material ----- ?

c. Functioning. Apparently, upon firing, setback force causes the stirrup (3) to move rearward and engage the detonator carrier (5). During flight the detonator carrier is prevented from moving forward by the anticreep spring (1). On impact with the target inertia causes the stirrup and the attached detonator carrier to move forward until the detonator (6), which is secured to the detonator carrier, strikes the fixed firing pin (2). At this point, the detonator is approximately in the center of the booster (4). The explosion of the detonator initiates the booster, which activates the main charge of the projectile.

d. Weapons and projectiles with which used. Information is not available as to the specific naval and coastal artillery weapons or ammunition associated with this fuze.

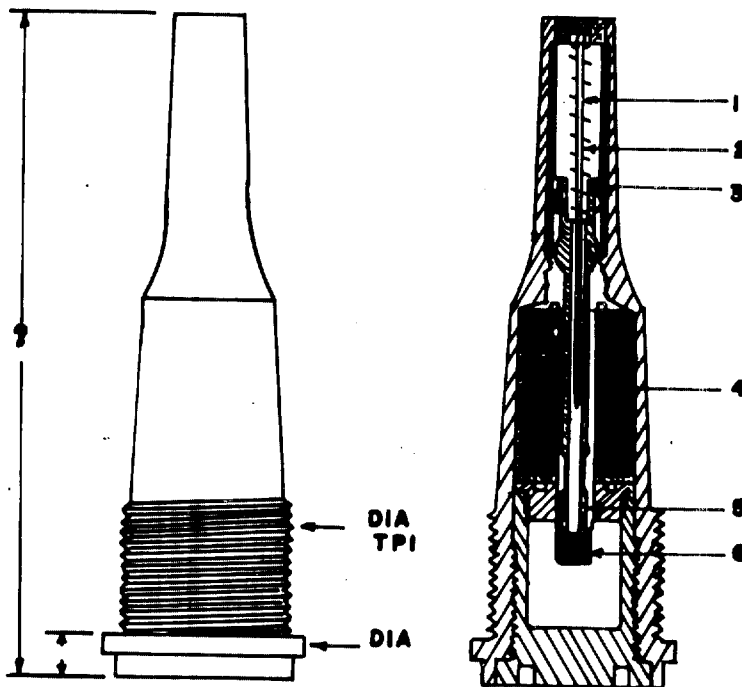

5-47/5-48

SOVIET BASE DETONATING IMPACT FUZE MODEL 10 DT

a. General. The 10 DT is unusual in that it has an automatic mechanism which enables it to function as either a nondelay or delay action fuze without setting previous to firing. This feature enables the fuze to detonate a projectile almost instantaneously upon encountering a thin-skinned target, or after a delay upon encountering a thick-skinned target, thus allowing the time necessary to embed the projectile in the target before detonation. The 10 DT, which is fired only in large caliber weapons, differs slightly for each type weapon in which it is used. This difference is necessitated by the difference in terminal velocity, which dictates the tensile strength of the shutter wire (12) that controls the action of the fuze (c below).

b. Characteristics.

Action ----- nondelay and delay

Loaded weight ----- ?

Body material ----- ?

c. Functioning. On firing, the stirrup (8) sets back, cutting the shear pin (14). The stirrup safety clamp (10) is crushed, and the stirrup remains to the rear, fixed with the striker (11) as one piece. The striker, though its forward movement is no longer prevented by the stirrup, is held to the rear by the anticreep spring (7) until impact. On impact with a thick-skinned target, the stirrup and striker move forward, carrying the impact firing pin (9) into the primer (6). At the same time the metal shutter (13) cuts the shear wire (12), and sets forward to plug the direct flash channel that leads to the black powder pellet (4). The flash from the primer (6) ignites the delay pellet (5) which burns through and ignites the black powder pellet. Gases from the burning black powder pellet drive the detonator firing pin (3) into the detonator. The detonator actuates the booster (1), which in turn explodes the projectile. On impact with a thin-skinned target, the force of inertia is not sufficient for the metal shutter (13) to cut the shear wire (12) and plug the direct flash channel to the black powder pellet (4). Therefore, the primer flash is transmitted directly to the black powder pellet, bypassing the delay pellet (5), so that the action of the fuze is accelerated.

d. Weapons and projectiles with which used: The 10 DT is used with armor-piercing and concrete-piercing projectiles in weapons of 152-mm or larger. The specific using weapon and projectile has not been identified.

SOVIET BASE DETONATING IMPACT FUZE MOD. L 10 DT

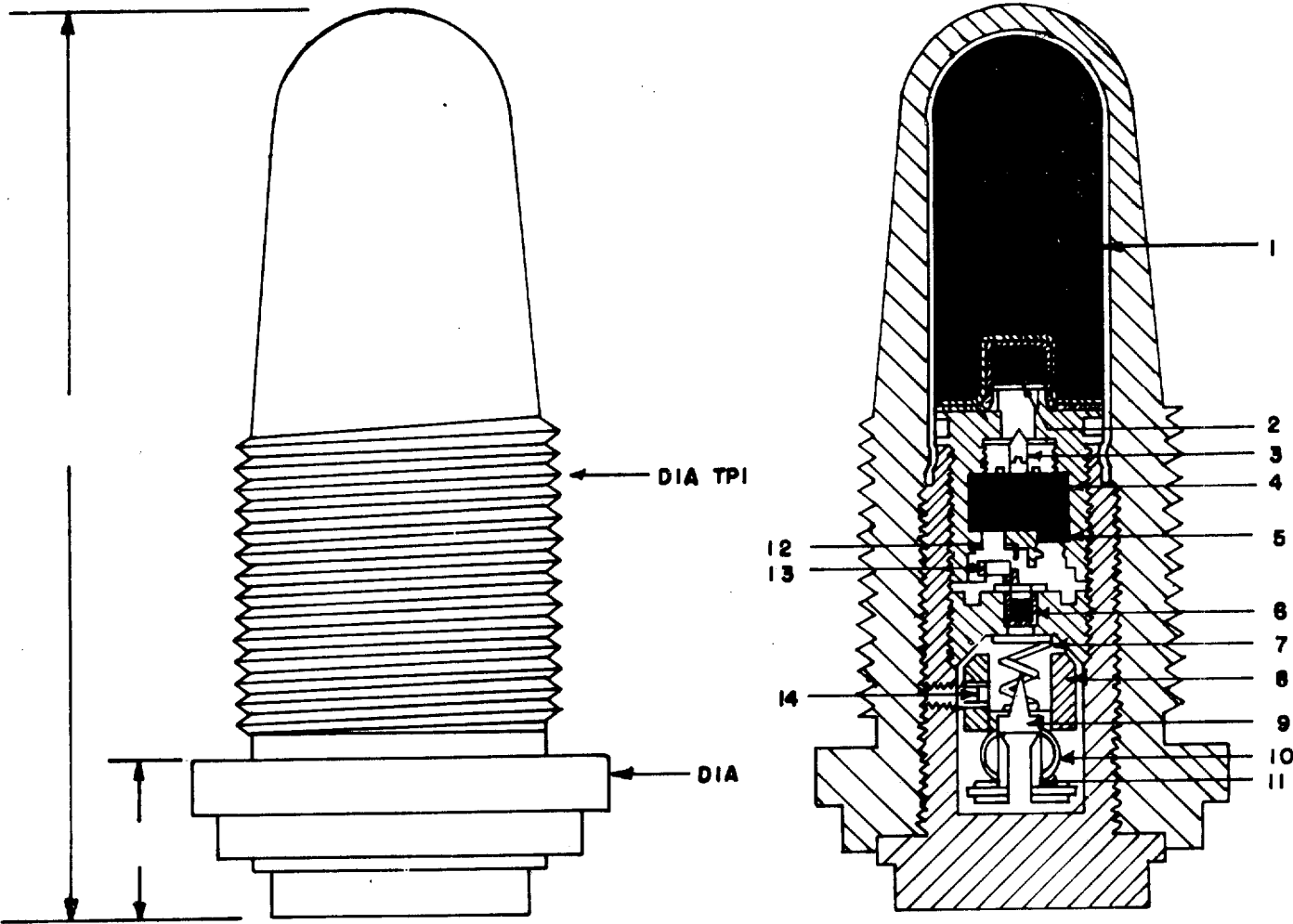

CHAPTER 6

CHINESE COMMUNIST BASE DETONATING FUZES

6-1.1

## CHINESE COMMUNIST BASE DETONATING FUZES

Chinese Communist base detonating fuzes are all exact copies of their Soviet counterparts. In many instances it appears that the ChiCom fuzes were made on the same machines that produced the Soviet fuzes. The only differences noted was in the marking of the fuzes. For this reason all general remarks made on Soviet base detonating fuzes are equally applicable to the ChiCom fuzes.

Since the ChiCom munitions industry has displayed the ability to produce quality explosive ordnance from indigenous designs, it is expected that new base detonating fuzes will appear based entirely upon native designs. **This trend is evident** in projectiles and point detonating fuzes. However, Soviet munitions design philosophies will continue to be employed as standard guides.

6-1.2

CHICOM BASE DETONATING IMPACT FUZE TYPE 2 (ARTILLERY)

a. General. The ChiCom base detonating fuze, Type 2, is an exact copy of the Soviet DBR-2 Base Detonating Impact Fuze. Differences were noted only in the paint and markings. For a more complete description of the ChiCom Type 2 see the Soviet DBR-2

b. Characteristics.

Action ----- Impact inertia

Loaded weight ----- 372 grams (0.81 lbs.)

Body material ----- steel

c. Functioning. See the Soviet DBR-2 for functioning information.

d. Weapons and projectiles with which used.

85-mm ChiCom Field Gun Type ?

85-mm APBC-T ----- 367 Series

CHICOM BASE DETONATING IMPACT FUZE TYPE 2 (ARTILLERY)

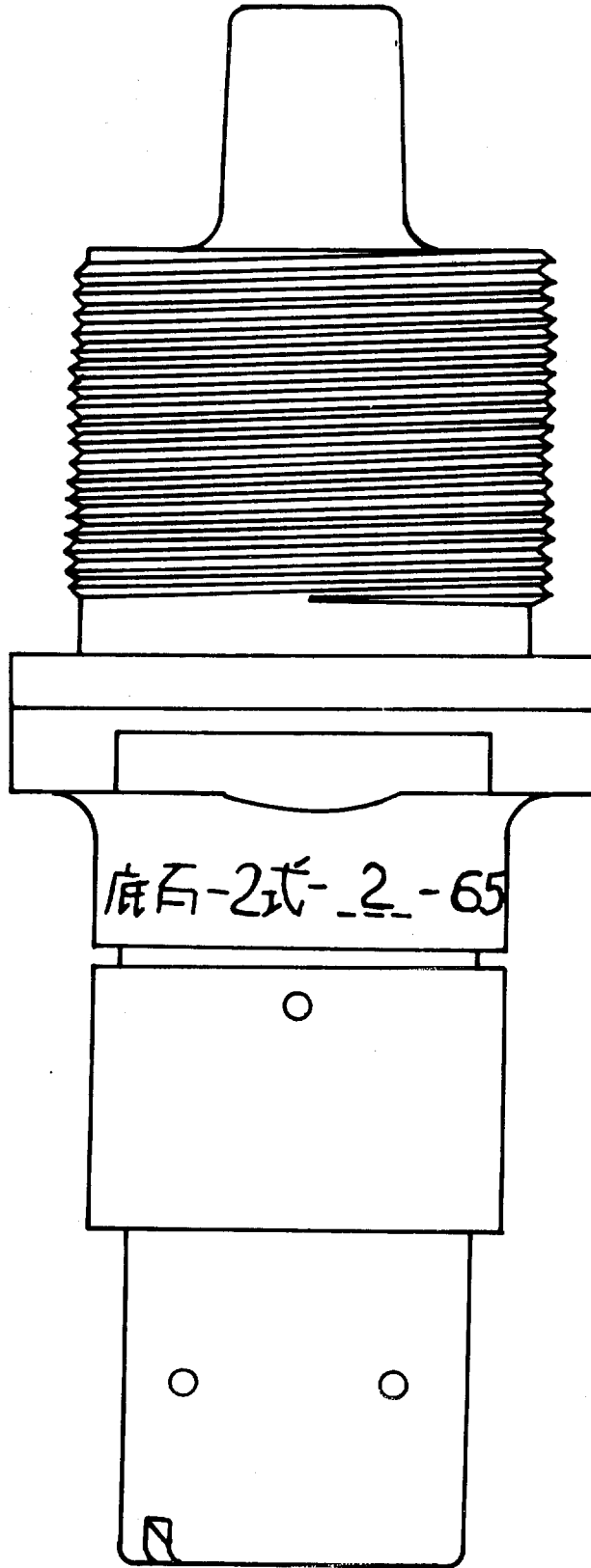

6-2

CHICOM BASE DETONATING IMPACT FUZE TYPE 2 (GRENADE LAUNCHER)

a. General. The ChiCom base detonating impact fuze Type 2 (Grenade Launcher) is an identical copy of the Soviet DK-2 fuze employed in the Soviet PG-2 grenade. For a discussion of this fuze see the entry under the Soviet DK-2 fuze.

b. Characteristics.

Action ----- Instantaneous

Loaded weight ----- 98 grams (0.23 lbs.)

Body material ----- Aluminium

c. Functioning. For a detailed discussion of the functioning of this fuze, see the entry made under the Soviet DK-2 fuze.

d. Weapons and projectiles with which used.

Weapons	Projectiles
40/80-mm: ChiCom Type 56 AT Grenade Launcher	40/80-mm HEAT ----- Type 50

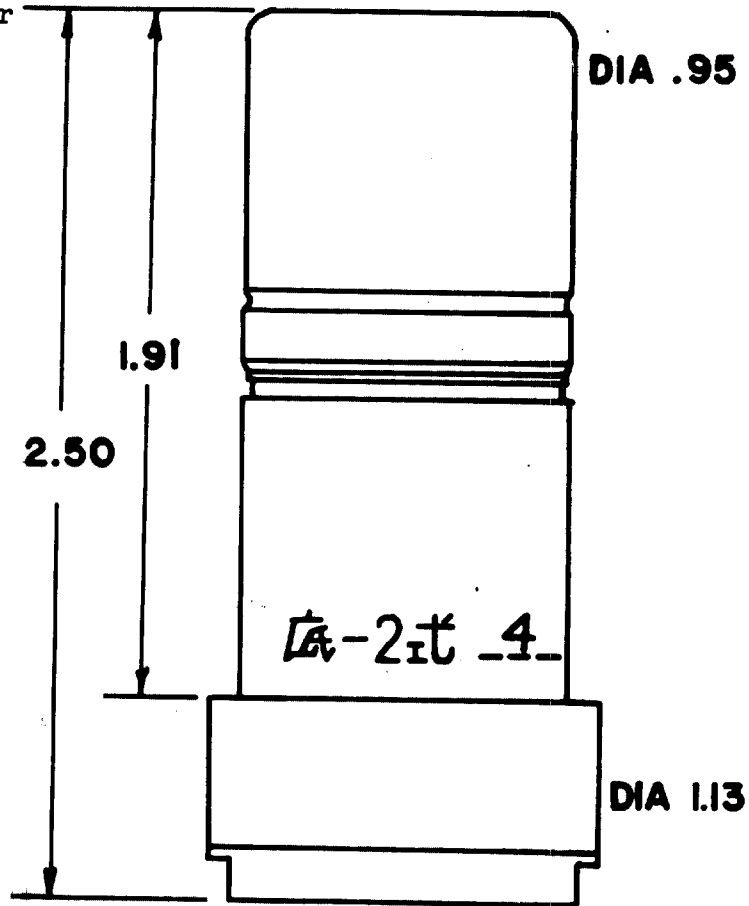

CHAPTER 7

MISCELLANEOUS CONCEPTS ALSO ASSOCIATED WITH METONATING MIXES

7-1.1

## MISCELLANEOUS COMMUNIST BLOC BASE DETONATING FUZES

This miscellaneous Communist Bloc base detonating fuze chapter is necessary due to the increasing number of base detonating fuzes credited to countries in the bloc other than the major suppliers; Soviet Russia and Communist China. Fuzes have been recovered which are native to Poland and North Vietnam. In addition, fuzes produced in North Korea and Rumania that are copies of their Soviet counterparts have been recovered and examined.

Since the Rumanian VP-7, piezo-electric, point initiating-base detonating fuze is an exact copy of the Soviet VP-7 and markings appear in Gothic letters and Arabic numerals, which are readily identifiable in English, it was not felt necessary to make a separate listing of the fuze under Rumania. The fuze is adequately covered under its Soviet counterpart.

NORTH KOREAN BASE DETONATING IMPACT FUZES, TYPE 2 (GRENADE LAUNCHER)

a. General. The North Korean base detonating impact fuze type 2 (Grenade Launcher) is practically an identical copy of the Soviet DK-2 and the ChiCom type 2 employed in the PG-2 grenade. The only major difference is in the body material. The North Korean fuze employs cadmium slated steel in lieu of aluminum, as in the case of its Soviet and ChiCom counterparts. Workmanship and close adherence to tolerances leave little to be desired. The fuze is entirely waterproof. For a discussion of the fuze employed in the PG-2, boosted grenade, see the entry under the Soviet DK-2.

b. Characteristics.

Action ----- Instantaneous  
Loaded weight ----- 105 grams (0.23 lb)  
Body material ----- Steel

c. Functioning. For a detailed discussion of the functioning of this fuze, see the entry for the Soviet DK-2 fuze.

d. Weapons and projectiles with which used.

<u>Weapons</u>	<u>Projectiles</u>
40/80mm: North Korean Copy of RPG-2	40/80mm HEAT Grenade

NORTH KOREAN BASE DETONATING IMPACT FUZES, TYPE 2 (GRENADE LAUNCHER)

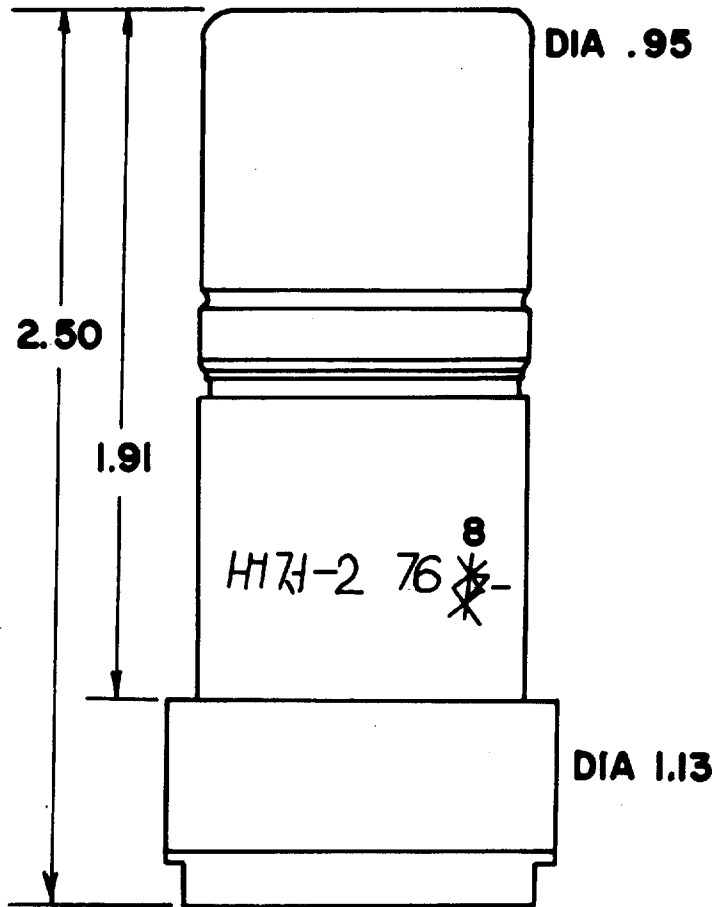

NORTH VIETNAMESE BASE DETONATING IMPACT FUZE B-50

a. General. The B-50 base detonating fuze is employed in the B-50 boosted grenade. The fuze presents no new features worthy of note. However, it is bore safe, non-detonator safe and appears reliable. It is an impact inertia fuze that employs a jump-out pin as its lone safety device.

The fuze housing (2) is made of steel and is an intragal part of the warhead to stabilizer boom adapter. The booster cup (1) and lock plug (3) are made of aluminum. The cup (1) fits inside the plug (3). The plug has two wrench flats for assembly and disassembly. The internal fuze housing (11) is made of aluminum and directly houses the stainless steel, inertia firing pin (5). The primer-detonator (8) is secured by an aluminum adapter (9). The firing pin (5) is separated from the primer-detonator (8) by an anti-creep spring (10). Prior to firing the firing pin is retained in a locked condition by the brass jump-out pin (6) and spring (7). The fin assembly of the B-50 grenade retains the jump-out pin within the fuze housing until firing.

b. Characteristics.

Action ----- Non-delay (impact inertia)

Loaded weight ----- N/A

Body Material ----- Steel and aluminum

c. Functioning. Upon firing the B-50 grenade inertia causes the fin assembly to shear a pin and move to the rear of the wooden boom. This uncovers the jump-out pin (6) which is expelled from the fuze housing (2), by the jump-out pin spring (7). This frees the firing pin (5) which is held away from the primer detonator (8) only by the anti-creep spring (10). The fuze is now armed. When the grenade impacts the inertia firing pin (5) moves forward and presses the stab-sensitive primer-detonator (8). This initiates the booster (1) and the shaped charge warhead of the B-50 grenade.

d. Weapons and projectiles used with.

Weapons	Projectiles
50/100mm: NVA/VC grenade launcher B-50	50/100mm HEAT grenade-----Type B-50

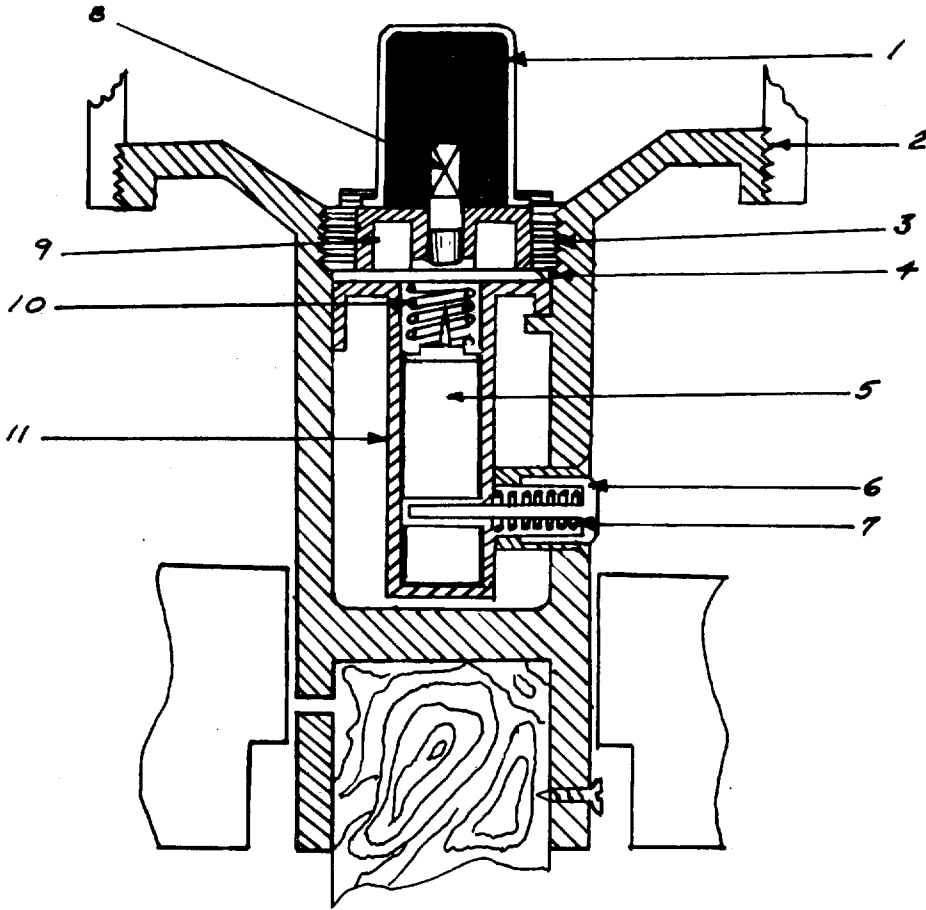

POLISH BASE DETONATING IMPACT FUZE DC-1

a. General. The Polish DC-1 base detonating, impact inertia fuze functions non-delay upon direct impact with a target. It is an extremely safe, very reliable fuze incorporating a graze-sensitive weight. In the unfired condition, all internal components are interlocked, effectively producing handling and bore safety. The fuze is not detonator safe. Following the practice of the French STRIM rifle grenade fuze, the DC-1 arms only upon the positive application of high pressure propelling gases on the rear diaphragm (12) and set-back.

The fuze is a completely sealed, waterproof assembly, made from a machined steel cylinder with closing discs at each end. The fuze body is roll crimped at each end to hold the discs in place. The discs are further sealed with shellac. The lower disc is embossed in three lines with fuze identification information. The upper fuze disc contains the primer-flash element. Two hemispherical spanner wrench grooves are cut into the external shoulder of the fuze body.

The machined steel body (1<sup>a</sup>) is the rigid element of the fuze and contains all arming and firing components. The lower disc (12) acts as the arming diaphragm. Internally, resting on the diaphragm and supported by the cam block (10) is a small piston (11) that is forced upward by the diaphragm. The piston (11) passes through the cam block (10) and forces a second piston (8) forward. The two pistons are then disengaged to permit the graze sensitive weight (9) to move laterally. The second piston (8) passes through the weight (9) and has its enlarged head positioned firmly against a slightly bent wire (7). This wire rests in a groove cut through the firing pin plunger (5). Each end of the wire (7) rests under the set-back weight (6) preventing it from moving downward. Inside the set-back weight (6) is a coiled, spring steel, clock type spring (4). This spring is held coiled by the set-back weight (6) and is positioned over the firing pin plunger (5) presenting a solid block against any forward movement of the firing pin (13) toward the primer (1). An anti-creep spring (14) separates the firing pin (13) and primer (1) when the fuze is armed. One end of the spring rests in a groove cut into the face of the firing pin plunger (5). The other end, which is slightly larger in diameter, fits over a guide beneath the primer. The cam block (10) and graze sensitive weight (9) are cut on an angle so that at near flat angles of impact, the weight (9) will move laterally and be cammed forward, forcing the firing pin assembly into the primer.

b. Characteristics.

Action ----- Non-delay  
Loaded weight ----- 57 grams (0.12 lbs)  
Body material ----- Steel

POLISH BASE DETONATING IMPACT FUZE DC-1

c. Functioning. There are no fuze safety devices to be removed prior to firing. When the high pressure propelling gases force the diaphragm (12) inward the lower piston (11) moves forward against the upper arming piston (8). The upper piston bends the wire (7) inward causing the wire ends to be pulled inward, unblock the set-back weight (6) at this time the two pistons are disengaged, permitting free, lateral movement of the graze sensitive weight (9). Set-back causes the weight (6) to move downward, releasing the coiled safety spring (4), which uncoils and expands into the fuze cavity. The positive block has now been removed from the firing pin (13) and the fuze is armed.

Upon impact, the firing pin assembly (5) compresses the anti-creep springs (14) and the sharp pointed firing pin (13) pierces the stab-sensitive primer (1) initiating the grenade explosive train. If the grenade impacts at a flat angle or attempts ricochet, the graze sensitive weight (9) will move laterally, through inertia and be cammed forward by the cam block (10), moving the firing pin assembly (5) into the primer (1).

d. Weapons and projectiles used with.

Polish Rifle Grenade, HEAT PGN-60

Polish Rifle Grenade, Fragmentation, F-IR-60

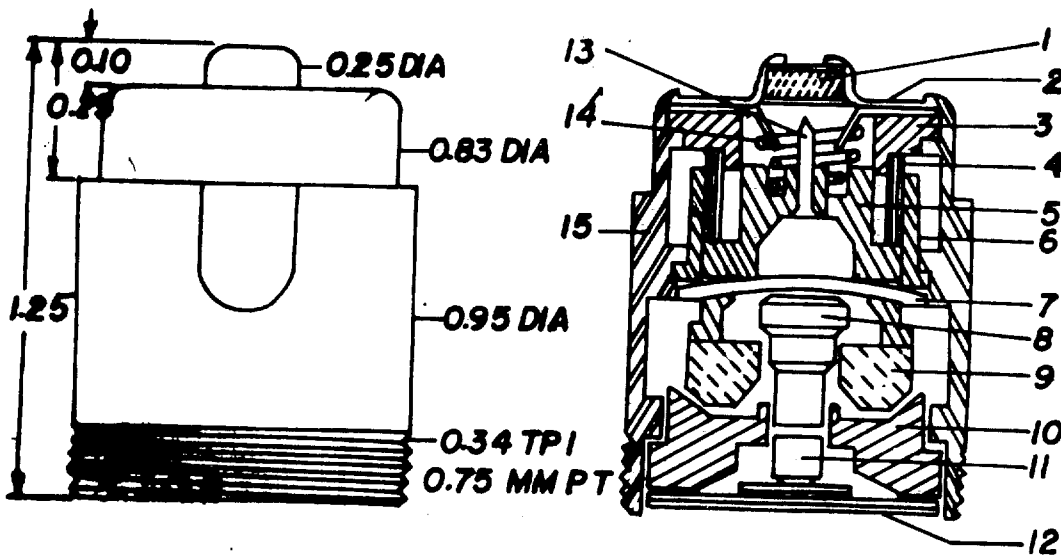

**CHAPTER 8**

**SOVIET TIME AND COMBINATION FUZES**

8-1.1

## SOVIET TIME AND COMBINATION FUZES

The Soviets possess and distribute to the Communist Bloc a complete range of time fuzes and combination and impact fuzes. These fuzes are both the mechanical time and powder time train types.

Tactically the major population of this fuze class is employed in an antiaircraft role. However, it appears that an increasing proportion are being employed as air burst on anti-personnel missions. Currently, both powder time train fuzes and mechanical time fuzes have been seen only in medium caliber projectiles, such as the 85mm and 100mm. This suggests that the antiaircraft guns are being employed as terrestrial artillery on certain fire missions.

The greater majority of the time fuzes recovered have been the powder time train T-5 and the mechanical time VM-30. Both of these fuzes require a wide mouth projectile capable of accepting a 2.03 diameter intrusion at 9 threads per inch. Standard point detonating fuzes with their 1.40 intrusion at 10 threads per inch cannot be fitted to the wide mouth 85mm G-365 projectile and the 100mm F-412 projectile. The projectiles may be employed interchangeably between antiaircraft and terrestrial field artillery weapons.

Powder time train fuzes employing pressed black powder in time rings are notoriously affected by altitude and humidity. Burning rates may vary to such an extent to render the fuze ineffective for anti-aircraft purposes. For this reason most countries now employ mechanical time fuzes in the antiaircraft role. However, mechanical time fuzes are more expensive and more difficult to manufacture. The Soviets took cognizance of the advantages and disadvantages of powder time train fuzes and initiated a redevelopment program. Since the pressed black powder delay train produced the undesirable factor, this material is being replaced by a non-gaseous, dichromate, burning mixture that is relatively unaffected by the antiaircraft envelope. Because of this redevelopment powder time train fuzes have retained their position within the Soviet fuze family.

It is known that the Soviet have developed mechanical time and powder time train fuzes that are not covered in this document. The VM-60 and TM-16L are notable examples. There have not been sufficient fuze fragments collected to positively identify these fuzes.

It is also known that the Soviets and other members of the Communist Bloc possess variable time (VT) fuzes. There is evidence that this class of fuze may have been employed in Vietnam, but this has not been solidified by fuze fragments or fuzes.

Currently, no time fuzes or combination fuzes of ChiCom manufacture have been recovered. It is certain that such fuzes exist, if only for antiaircraft purposes, but all dud ChiCom 85mm and 100mm antiaircraft projectiles recovered have been equipped with Soviet fuzes.

SOVIET POINT DETONATING COMBINATION FUZE MODEL D

a. General. The Model D fuze is provided with a threaded protective cover (not shown). The initial setting of the fuze, as issued, is "K", for canister action. Upon loading the shell, the protective fuze cover is removed (right-hand thread), and the fuze is set by turning the bottom time ring until the desired graduation of the scale is in line with the setting index on the platform of the fuze body. The burning time may be adjusted from 1 through 21 seconds. The time mechanism consists of two time rings. On the external surface of the bottom time ring is engraved a scale of 100 or 130 sight graduations, the value of each graduation being 50 m., and, in addition to this, two lines marked with the Russian letters "K" and "YA", which correspond to the settings of the fuze for canister effect and for nondelay (impact) action, respectively. The graduation scale of the fuze corresponds to the sights of the 76-mm regimental gun (howitzer) M1927. Special firing tables are required to use the fuze in other 76-mm guns. The Model D fuze is believed to be obsolete.

b. Characteristics.

Action ----- Time and nondelay  
Loaded weight ----- 400 grams (0.882 lb.)  
Body material ----- Brass

c. Functioning. No reliable information on the functioning of this fuze is now available.

d. Weapons and projectiles with which used.

Weapons	Projectiles
76-mm: divisional guns M1902/30, M1933, M1936 (F-22), M1939 (USV), and M1942 (ZIS-3); regimental gun (howitzer) M1927; tank guns M1927/32 and M1938/39 (L-11); mountain gun (howitzer) M1909	76-mm Shrapnel ----- Sh-354 Incendiary ----- Z-354S

SOVIET POINT DETONATING COMBINATION FUZE MODEL D

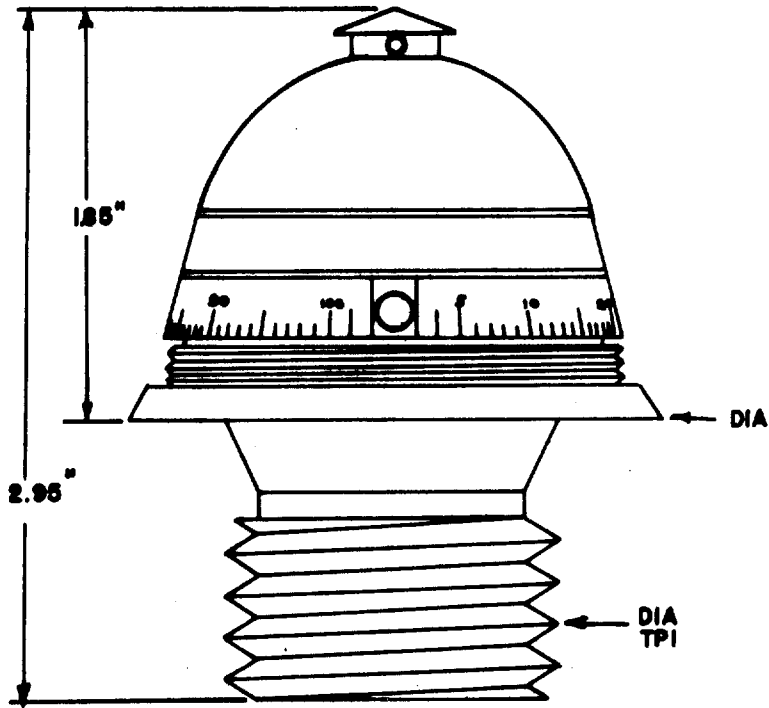

a. General. The maximum burning time of the D-1 fuze varies from 35 to 45 seconds, depending on the conditions under which it is used. The bottom time ring (6) has a scale of 125 graduations; the minimum setting on this scale is 10 graduations on the older D-1 fuzes, and 5 graduations on the newer ones. If the fuze is set between 115 and 125, the impact mechanism will not arm. Nondelay (impact) action is obtained by setting the bottom time ring at "УД."

b. Characteristics.

Action ----- time and nondelay  
 Loaded weight ----- 430 gm. (0.946 lb.)  
 Body material ----- brass

c. Functioning.

(1) For a time setting: Upon firing, the setback striker (11) sets back, igniting the initiating pellet (12), which ignites the powder train in the upper time ring (2). The flame travels around the upper time ring, burns through a transmission hole, and ignites the powder in the middle time ring (4), at the same time igniting a powder blocking pellet (13). The blocking pellet burns away, releasing the safety interrupter (3). Centrifugal force causes the safety interrupter to move outward. This action is also accelerated by the safety interrupter spring. This action frees the impact striker (1), which will activate the fuze in the event the projectile strikes an object before the powder train is consumed. Meanwhile the flame from the middle time ring passes into the lower time ring (6) through the flash channel (14), and then through a flash channel in the safety rotor (8) (which has been centrifugally rotated to align its flash channel with the detonator pellet (9)). The flame thus reaches the detonator pellet (9), which activates the booster (10), exploding the projectile filler.

(2) For nondelay (impact) action (setting "УД"): The "УД" setting positions the time rings so that the maximum burning time of 45 seconds is assured. Up until the moment of impact, the fuze functions exactly as described above. Upon impact, the impact striker (1) is driven rearward and forces the firing pin (5) into a primer (7) aligned with the flash channel of the safety rotor (8). Flame from this primer passes to the detonator pellet (9), which then sets off the booster (10) and the projectile filler.

SOVIET POINT DETONATING COMBINATION FUZE MODEL D-1

d. Weapons and projectiles with which used.

Weapons	Projectiles
107-mm: corps guns M1910/30 and M1940 (M-60)	107-mm Frag-HE ----- OF-420
122-mm: corps guns M1931 and M1931/37 (A-19); tank gun M1943 (D-25); SP gun M1944 (A-19S)	122-mm Frag-HE - OF-462; OF-471; OF-471N
152-mm: gun M1910/34; gun-howitzer M1937 (M1-20)	152-mm Frag-HE -- OF-530; OF-540

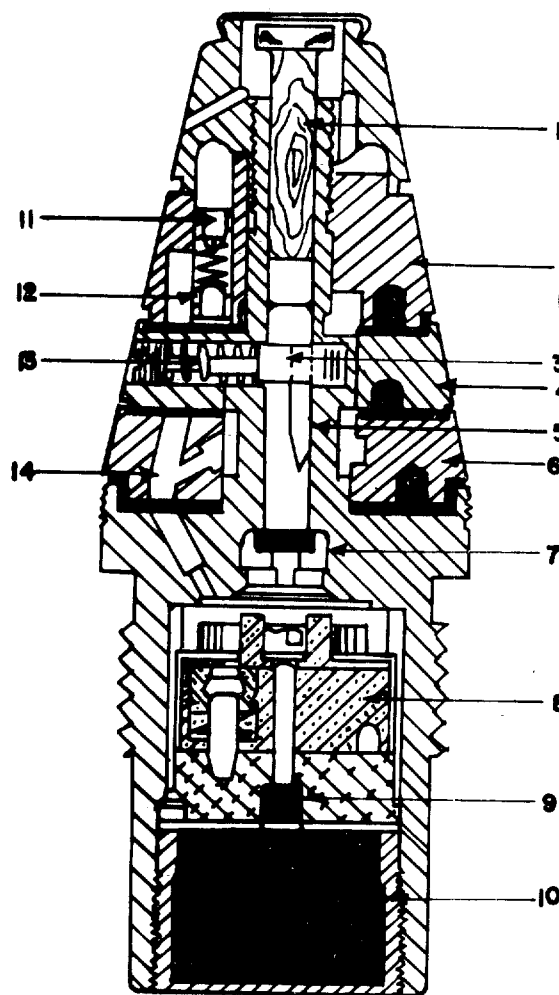
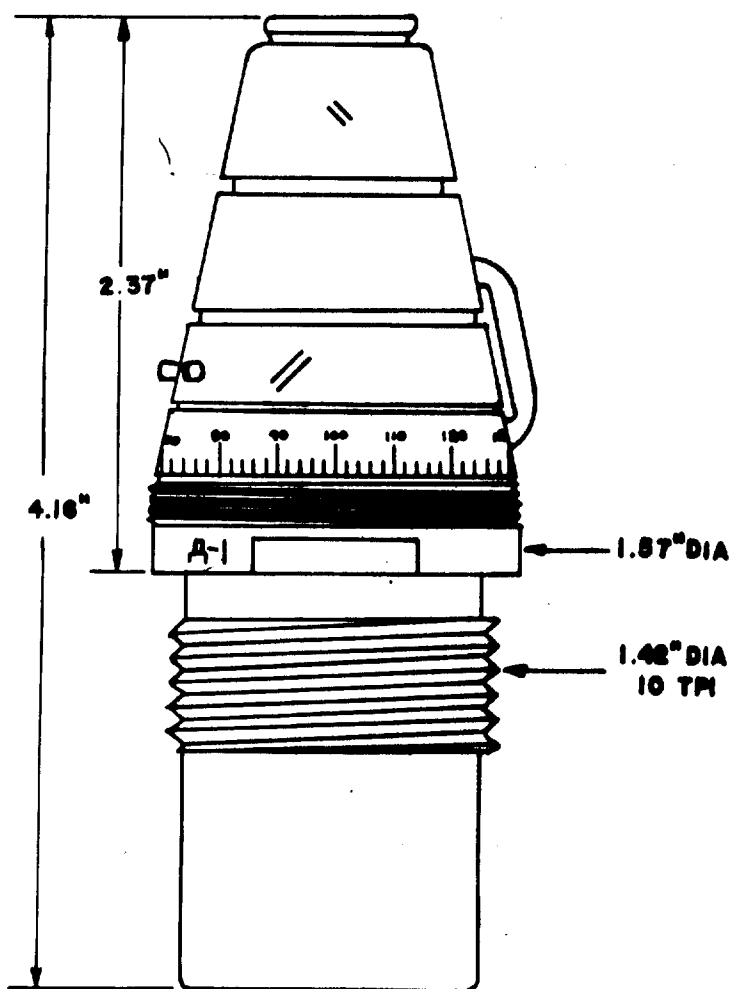

SOVIET POINT DETONATING COMBINATION FUZE MODEL OM-82

a. General. The OM-82 is a powder train time fuze used to ignite the expelling charge in the Soviet 82-mm mortar propaganda shells. The base portion of the body is threaded, apparently to receive a safety cap. No data is available on the safety cap.

b. Characteristics.

Action ----- time

Loaded weight ----- ?

Body materials ----- brass and steel

c. Functioning. When the round is fired, setback causes the firing pin (1) to overcome the resistance of the spring (2) and move rearward until it strikes and ignites the primer (4). The flash from the primer moves along a flash channel until it ignites the powder train in the upper time ring (3). The burning powder train follows a path within the upper time ring (3), through a passage to the center time ring (5), within the center time ring (5), through a passage to the lower time ring (6), to flash channel (8), and then ignites the powder magazine (7), which in turn functions the bursting charge of the projectile.

d. Weapons and projectiles with which used.

Weapons

Projectiles

82-mm: battalion mortars M1937  
(82-BM37), M1941 (82-BM41),  
and M1943 (82-BM43)

82-mm Propaganda ----- A-832

SOVIET POINT DETONATING COMBINATION FUZE MODEL OM-82

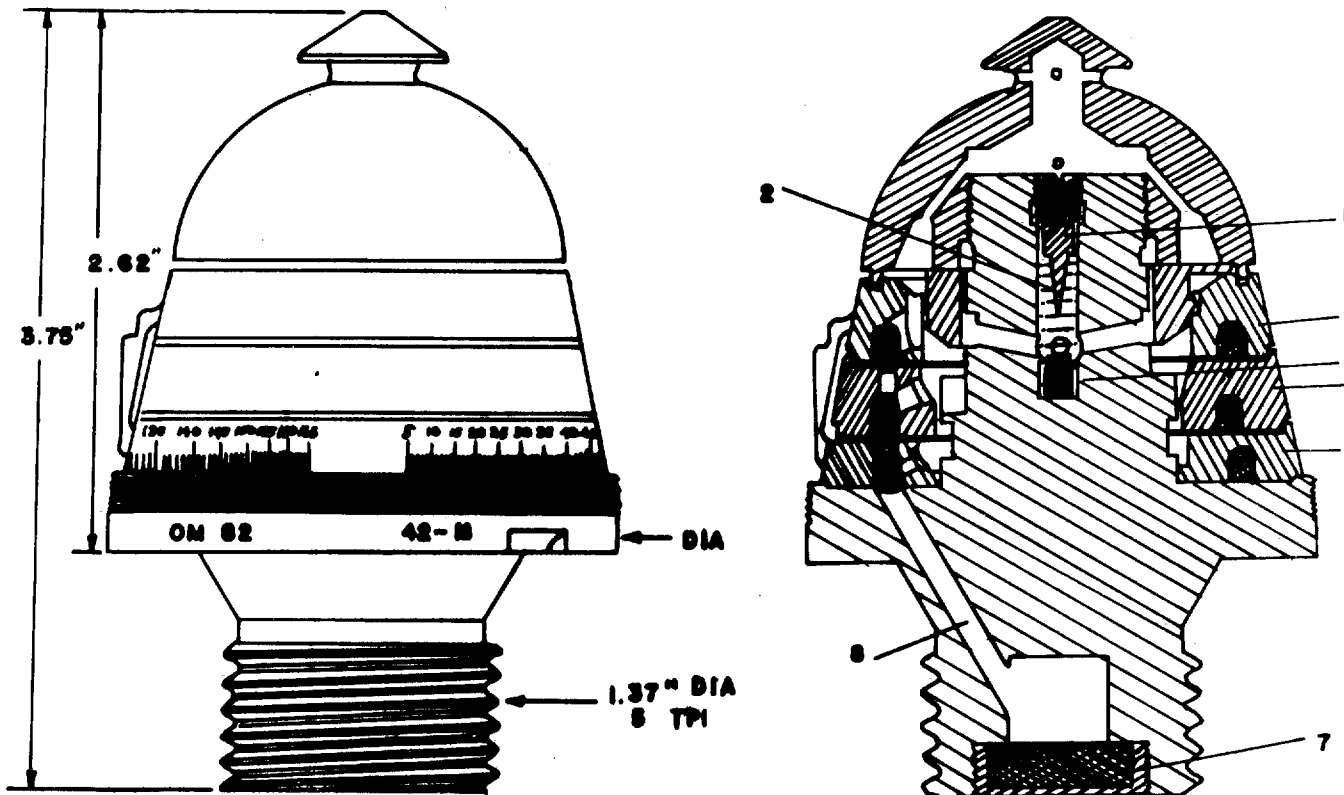

SOVIET POINT DETONATING TIME FUZE MODEL T-3

a. General. The T-3 fuze is used with shrapnel shells in 76-mm divisional, tank, and antiaircraft guns. It is used for both ground and antiaircraft fire. Construction of the T-3 fuze is simple in comparison to fuzes in the 22-second series and other time fuzes, but it is subject to failure during flight. This fuze has a setting scale graduated up to 32. This fuze will arm at a distance of 30 to 60 feet from the muzzle of the gun and has a maximum burning time of 21.7 seconds. The T-3 fuze does not have percussion action upon impact. The base portion of the fuze body is threaded for a safety cap which must be removed at the firing point.

<u>Setting</u>	<u>Action</u>
"YD" -----	will not function
"K" -----	canister
(Other) -----	time

b. Characteristics.

Action ----- Time, canister effect, and solid shot effect

Loaded weight ----- 650 grams (1.43 lb.)

Body material ----- Steel

c. Functioning. With the fuze set for time functioning, upon firing, setback causes the firing pin (1) to overcome the resistance of the spring (6) and move rearward until it strikes and ignites the primer (7). The flash from the primer is transmitted to the upper time ring (2), where it ignites the powder train. The burning powder train follows a path within the upper time ring (2), through a passage to the center time ring (3), within the center time ring through a passage to the lower time ring (4), and within the lower time ring to the channel (8). The burning powder train then flashes through the channel to ignite the black powder magazine (5) which functions the projectile. When the fuze is set on "K", for canister effect, the passages of the time rings are directly aligned to the channel (8); consequently, after the burning powder train consumes the path within the upper time ring (2), it goes directly to the channel, to the magazine, and functions the projectile. When the fuze is set on "YD", it will not function. The powder train in the upper time ring (2) is consumed, but the time rings have been positioned so that the passages are blocked and the powder train is prohibited from burning beyond the upper time ring. The "YD" setting results in the projectile having a solid shot effect against the target.

SOVIET POINT DETONATING TIME FUZE MODEL T-3

d. Weapons and projectiles with which used.

Weapons

76-mm: divisional guns M1902/30, M1933, M1936(F-22), M1939(USV), and M1942(ZIS-3); tank guns M1938/39 (L-11) and M1939.(F-32); anti-aircraft guns M1931, M1931/33, and M1938

Projectiles

76-mm Shrapnel—Sh-361; Sh361A; Sh-354R; Sh-355

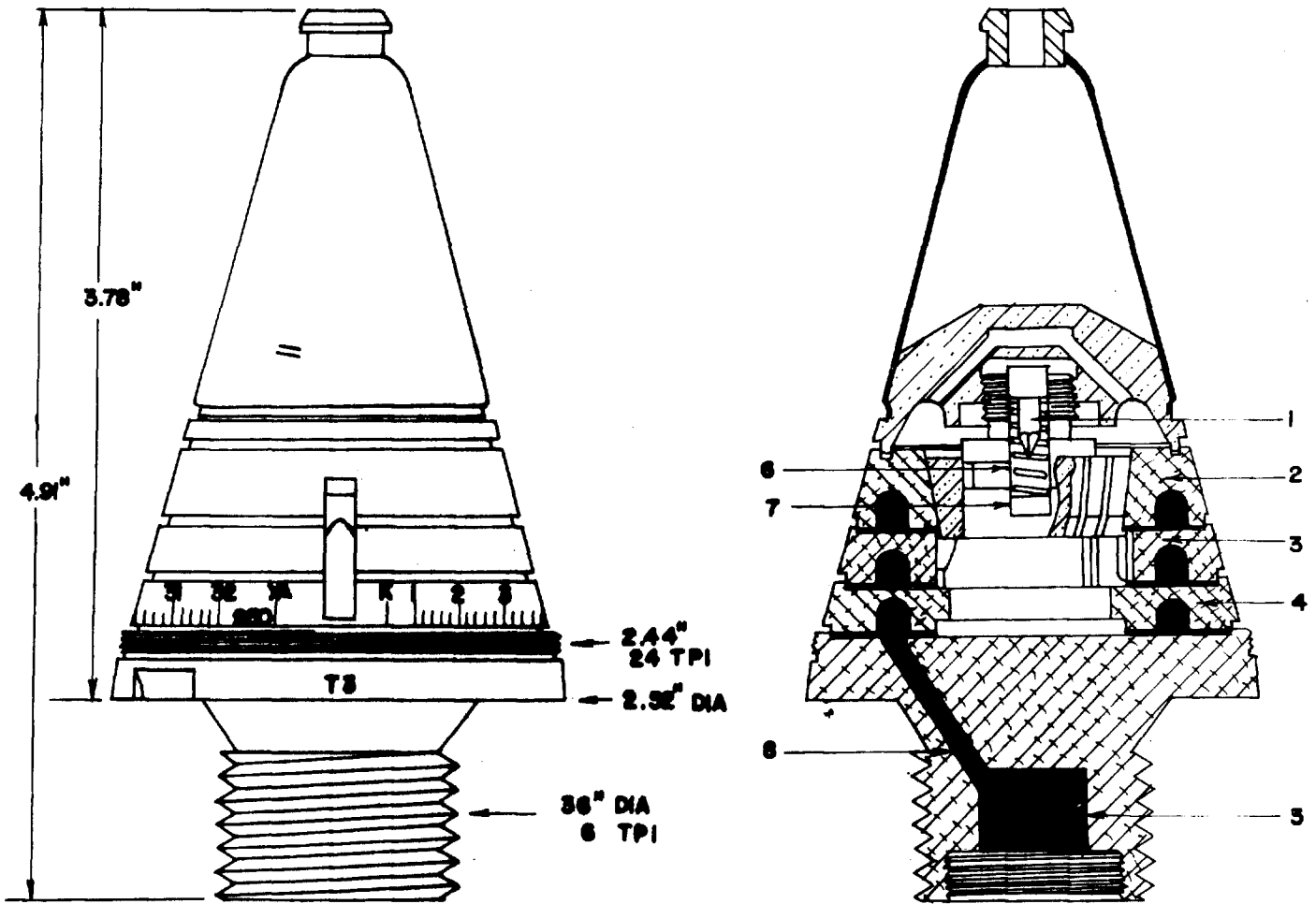

SOVIET POINT DETONATING TIME FUZE MODEL T3(UG)

a. General. The T3 (UG) (Trubka, 3-go Obraztsa, Uluchshennogo Gabarita: literally, "Fuze, 3rd Model, Improved Dimensions") was designed for use with bar shrapnel shells used in 76-mm antiaircraft guns and has been used with shrapnel projectiles for Soviet 76-mm divisional, regimental, and tank guns. This fuze is designed only for an air burst, since it contains no arrangement for impact functioning. This fuze has 165 graduations on the time scale ring. The maximum burning time of the T3 is 32 seconds. The powder train of the T3 fuze burns more uniformly than the powder train of the 45-second fuze because of the arrangement of openings in the nose and sides of the streamlined fuze windshield; consequently, the T3 has a greater height of action. This fuze is fitted with a safety cap which must be removed just prior to setting

<u>Setting</u>	<u>Action</u>
"YD" -----	solid shot effect (fuze does not function)
"K" -----	canister
(Other) -----	time

b. Characteristics.

Action ----- time, canister effect, and solid shot effect

Loaded weight ----- 636 grams (1.40 lb.)

Body material ----- steel

c. Functioning. The firing pin (1) is retained within the stem of the fuze body (5) by a retaining plug (8) and held away from the primer (10) by the spring (9). With the fuze set for time functioning, upon firing, setback causes the firing pin (1) to overcome the resistance of the spring (9) and move rearward until it strikes and ignites the primer (10). The flash from the primer is transmitted to the upper time ring (2) where it ignites the powder train. The burning powder train follows a path within the upper time ring (2), through a passage to the center time ring (3), within the center time ring through a passage to the lower time ring (4), and within the lower time ring to the channel (11). The burning powder train then flashes through the channel to ignite the black powder magazine (6) and send a jet of flame through base plug (7) to explode the projectile. When the fuze is set on "K" for canister effect, the passages of the time rings are directly aligned to the channel (11); consequently, after the burning powder train consumes the path within the upper time ring (2), it

SOVIET POINT DETONATING TIME FUZE MODEL T3(UG)

goes directly to the channel, to the magazine, and explodes the projectile at about 100 to 165 feet from the gun muzzle. Normally the T3(UG) fuze is not fired with the setting of "YD"; the exception would arise when no armor-piercing rounds were available and direct fire against tanks was needed. In this case, with the fuze set on "YD", the fuze would not function and the projectile would produce a solid shot effect against the target. When the fuze is fired with the "YD" setting, the powder train in the upper time ring (2) is consumed, but the time rings have been positioned so that the passages are blocked and the powder train is prohibited from burning beyond the upper time ring.

d. Weapons and projectiles with which used.

Weapons	Projectiles
76-mm: antiaircraft guns M1931, M1931/33 and M1938; divisional guns M1902 M1936(F-22), M1939(USV) and M1942 (ZIS-3); tank guns M1938/39(L-11) M1939(F-32), M1940(F-34), & M1941 (ZIS-5); regimental guns M1900, M1902, and M1927	76-mm Shrapnel ----- Sh-361
85-mm: tank gun M1944 (ZIS-S-53)	85-mm Frag ----- O-365

SOVIET POINT DETONATING TIME FUZE MODEL T3(UG)

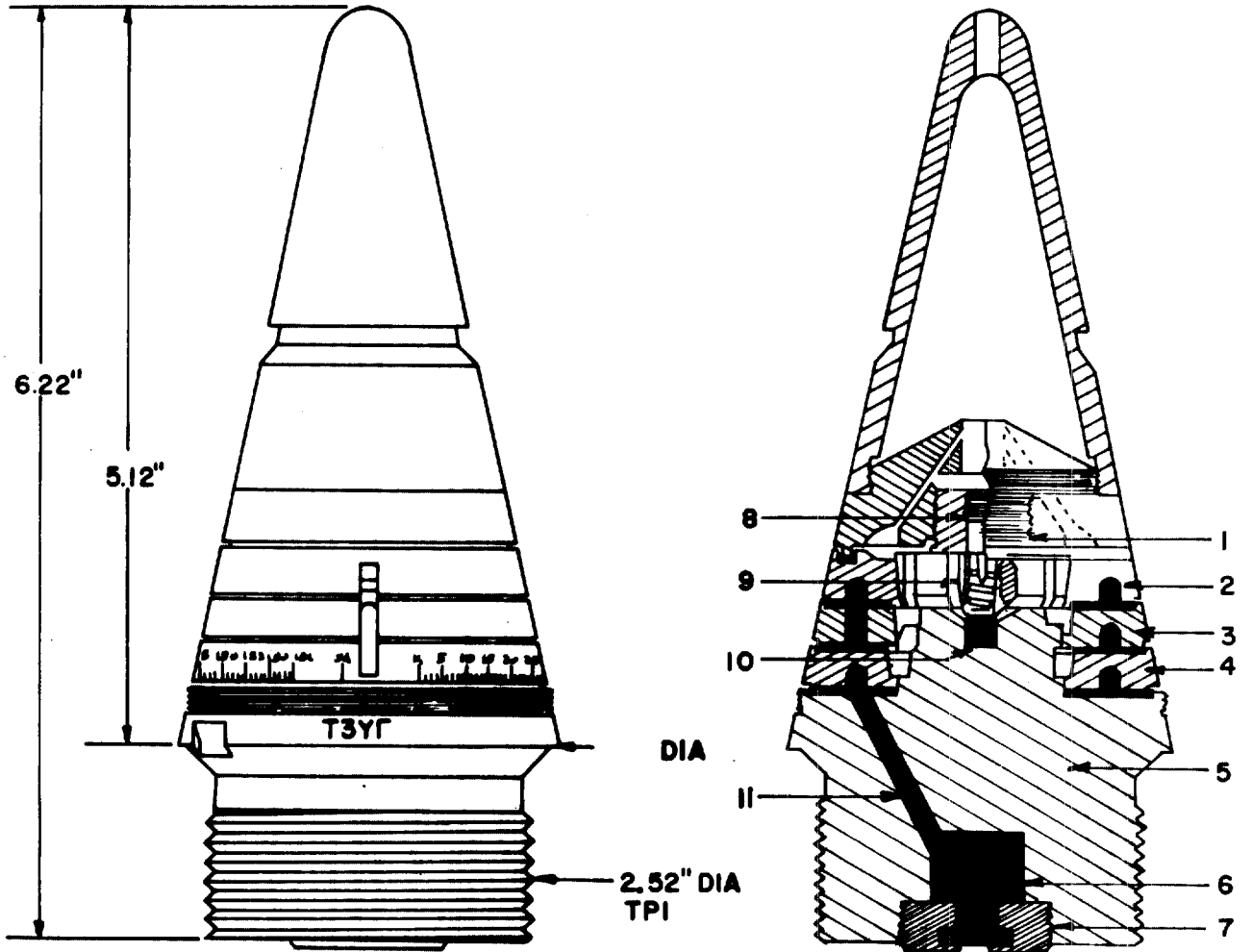

8-11/8-12

ring (3), when the projectile is fired the slider setback locking pin (7) overcomes the tension of its spring and sets back into the slider which houses the detonator to hold it immovable. As the projectile rotates through the bore centrifugal force causes the two slider locking pins, one on each side of the slider to compress their springs and move outward, away from the slider. After the projectile has left the bore and the setback force ceases, the slider setback locking pin spring returns the slider setback locking pin to its original position away from the slider.

SOVIET POINT DETONATING TIME FUZE MODEL T-5

Centrifugal force then acts upon the counterweight in the slider to move the slider so that the detonator in the slider becomes aligned with the flash channel (8) and the magazine charge or booster (4). At the same time, the firing pin (5) overcomes the resistance of its spring and moves rearward until it strikes and ignites the primer (6). The flash from the primer is transmitted to the upper time ring (1) where it ignites the powder train. If the fuze is set for time functioning, the powder train burns successively through the center time ring (2) and the lower time ring (3), passes the flame through the flash channel (8) to ignite the detonator in the slider, the detonator functions the booster, and the booster in turn explodes the projectile. If the fuze is set for canister effect the action is essentially the same except that the powder train burns through the time rings in the most direct manner and the projectile bursts dangerously close to the gun muzzle. If the fuze is set so as not to function, the time rings are positioned to stop the powder train from burning beyond the upper time ring.

d. Weapons and projectiles with which used.

Weapons

76-mm anti-aircraft guns M1931, M1931/33, and M1938	76-mm Frag -- 0-361; 6-361D
85-mm anti-aircraft gun M1939; tank guns M1943 (D-5T85) and M1944 (ZIS-S53); SP guns M1943 (D5-S85 and D5-S85A)	85-mm Frag ----- 0-365



T-5 fuze correspond to the sight graduations of the 75-mm gerimental gun M1927 and special range tables are needed if the fuze is to be employed in other weapons. Two additional indexes, "y" and "K", may appear stamped on the time scale rings of the T-5, T-6, and T-7 fuzes; however, more recently manufactured fuzes discard one or both of these indexes. The letters "y" indicate a setting whereby the shell functions with nondelay action on impact with the target. The letter "K" indicates a canister-effect setting to be used with shrapnel and fragmentation shells, but only in a last-ditch effort to defend a battery position. The "K" setting produces an airburst 65 to 100 feet from the gun.

b. Characteristics.

Action ----- time, nondelay, and canister effect

Loaded weight ----- 540 grams (1.19 lbs)

Body material ----- aluminum

c. Functioning. When the round is fired, the primer housing (12) in the base of the fuze body (5) is setback over the stirrup (7) and the prongs of the stirrup become engaged in a groove inside the primer housing in the rearmost position, thus arming the fuze for impact functioning. Simultaneously, the firing pin (9) overcomes the resistance of its spring and moves rearward until it strikes and ignites the primer (2). The flash from the primer is transmitted to the upper time ring (1) where it ignites the powder train. If the fuze is set for time functioning the powder train continues to burn successively through the center time ring (3) and the



SOVIET POINT DETONATING COMBINATION FUZE MODEL T-6

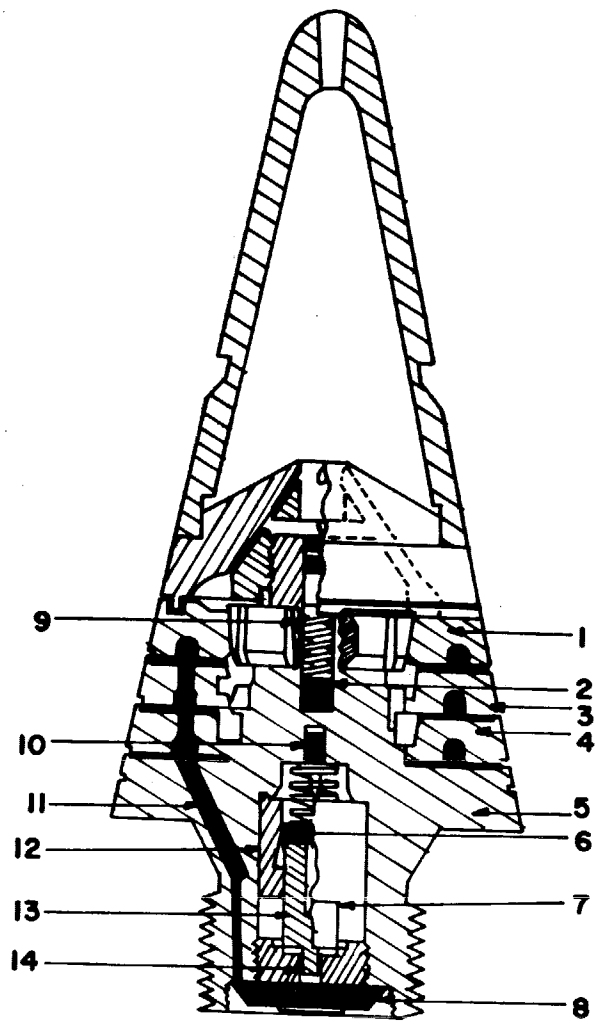
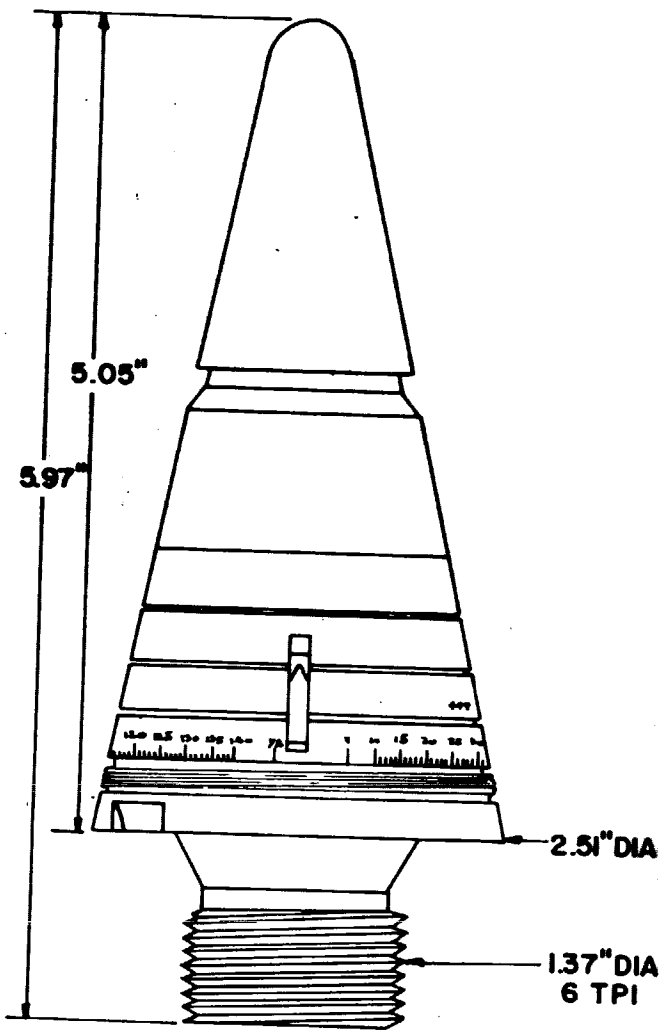

8-19/8-20

(13) and bushing (11) move forward by inertia, impaling the primer (8) on the fixed firing pin (9). Flame from the primer flashes into the magazine charge (10) functioning the projectile. When the fuze is set for muzzle burst action, the flame transfer channels in the three time rings are all set in line with the flash channel (6). The projectile will travel 65 to 100 feet from the muzzle before functioning. This setting is normally employed in cannister ammunition.

SOVIET POINT DETONATING COMBINATION FUZE MODEL T-7

d. Weapons and projectiles with which used.

Weapons	Projectiles
122-mm: howitzer M1938	122-mm Shrapnel ----- Sh-460T Illuminating ----- S-426 Propaganda ----- A-462
152-mm: howitzer M1943	152-mm Shrapnel ----- Sh-501T

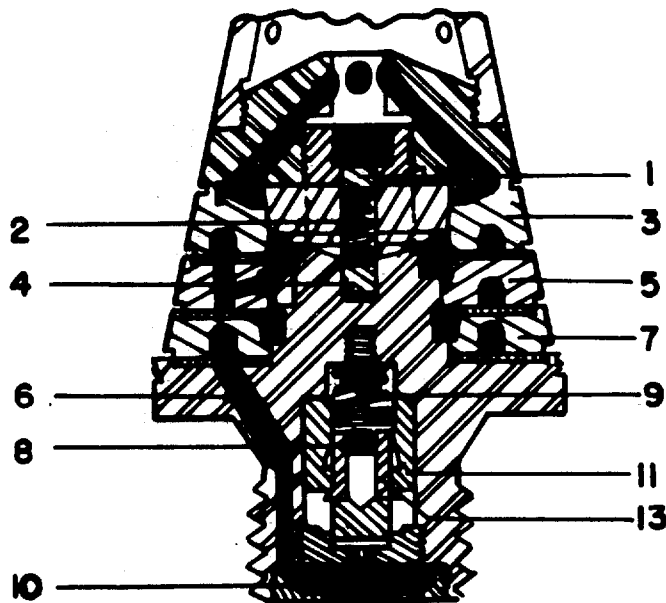

SOVIET POINT DETONATING IMPACT FUZE MODEL T-11

The T-11 time fuze is similar in overall appearance and construction to the T-5 fuze, but differs from the latter in having a time powder train of an improved slow-burning gasless powder composition. This composition burns more slowly than the usual powder used, and does not fail at high altitudes as does the powder used in the T-3 fuze. The T-11 does not have a percussion arrangement for impact firing, and must therefore be set only for aerial bursts. It is used with the O-361 and O-361D projectiles in the 76-mm antiaircraft guns M1931, M1931/33, and M1938

8-23/824

clockwork mechanism and has no provision for function upon impact. It can be set for longer burning time than any other Soviet fuze known to be used in the 85-mm antiaircraft gun M1939. The windshield and fuze body are made of aluminum; the locking ring and internal mechanism are made of brass. The settings in seconds are inscribed on the windshield and the time setting indicator point is inscribed on the fuze body. The fuze is set to desired time of function by rotating the windshield until the desired time graduation lines up with the indicator line on the fuze body. The entire fuze mechanism closely resembles the German ZT. Z S/30 artillery fuze which was used with 88-mm antiaircraft guns.

**b. Characteristics.**

Action ----- mechanical time  
 Loaded weight ----- 755 grams (1.66 lbs)  
 Body material ----- aluminum

**c. Functioning.** On firing, setback causes the trigger (8) to move rearward and release the hand (7). The hand, upon being released, is rotated in a counterclockwise direction by the main spring and clockwork mechanism. The complete clockwork mechanism has not been shown in the drawing. When the hand has cleared the safety bridge (1) it is pressed up against the hand race on the under surface of the top of the retainer cup (9) by a spring (2) under the center of the hand (7). When the hand reaches the portion of the hand race which is cut out to receive it, it is forced upward by its spring and the ring-like section of the hand clears the prong of the safety lever (3), allowing it to move outward under the pressure of its spring and centrifugal force. This pulls the lower section of the safety lever out of the safety slot of the firing pin (4), allowing the firing pin to go rearward under the influence of its spring and activate the primer (6) which in turn detonates the booster (10). The fuze has an additional safety feature in its spring-loaded shutter (5) which remains in place, blocking the primer from the firing pin until the centrifugal force of the rotation of the shell in flight pulls it to the side and leaves a clear passage to the primer.

**d. Weapons and projectiles with which used.**

Weapons	Projectiles
85-mm: antiaircraft gun M1939	85-mm Frag ----- O-365M

7.14"

DM-2

2.50"<sup>±0.005</sup>  
DIA

2.05" DIA  
9 TPI

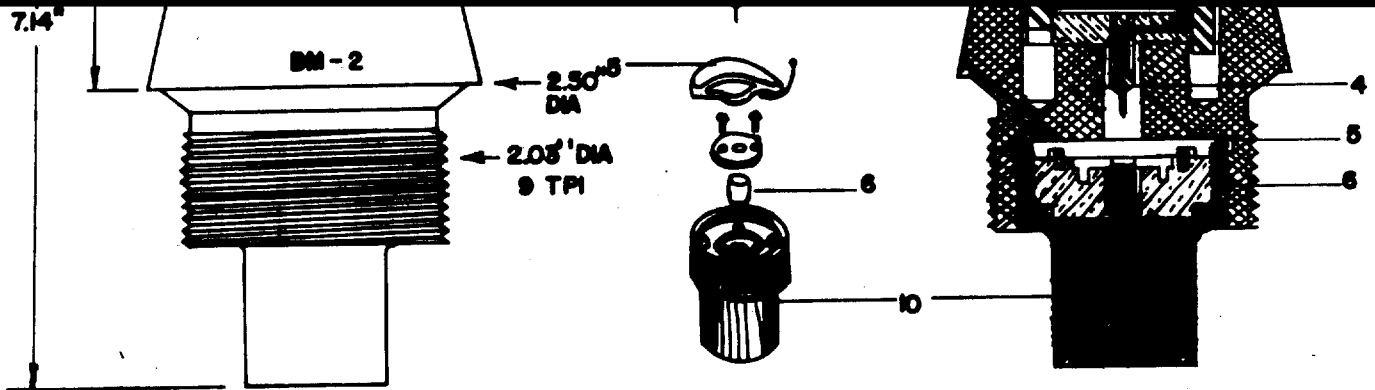

SOVIET MECHANICAL TIME FUZE VM-30

a. General. The Soviet Mechanical Time fuze VM-30 has not been recovered intact. Only fragments of various components have been studied. Due to the distortion of these fragments, caused by the detonating projectile it has not been entirely possible to reconstruct the fuze as in was the case with the U-429 and RGM series fuzes.

The VM-30 appears to have most of the characteristics of the VM-2. The clock type main spring is present along with a spring powered firing pin. Evidence is not conclusive, but the VM-30 may incorporate a centrifugally operated detonator slider of the type seen in the T-5 powder time train fuze. This would be in keeping with current fuze design philosophy on bore and detonator safe fuzes.

b. Characteristics.

Action ----- Mechanical, time

Loaded weight ----- Unknown

Body material ----- Aluminum

c. Functioning. Similar to the Soviet VM-2.

8-27/8-28

SOVIET POINT DETONATING COMBINATION FUZE MODEL 22G

a. General. The 22G is one of the fuzes in the 22-second series, which also includes the models 22-sec., 22P, and 22PG. The Model 22-sec. fuze appeared in 1899 and was standard until the outbreak of World War II. The 22G is similar to all other fuzes in the 22-second series in internal construction. The major difference between these fuzes lies in the arming safety arrangements. The 22G fuze may be set for time, canister, or nondelay action, as can all other fuzes of the 22-second series. Some of the fuzes in the series have been found with safety caps which are removed prior to firing. In all probability, the 22-second series fuzes have been replaced by the "T" series in the Soviet services.

<u>Setting</u>	<u>Action</u>
"0" - "130" graduations	----- Time
"YD"	-----Nondelay
"K"	-----Canister effect

b. Characteristics.

Action ----- Time, nondelay, and canister effect  
 Loaded weight ----- ?  
 Body material ----- Aluminum

c. Functioning. On firing, when the fuze is set for time action, the setback firing pin (1) overcomes the resistance of the primer carrier spring (2) and ignites the primer (10) which ignites the upper time ring (3) and lower time ring (4). When the lower time ring burns through, the flame passes through the flash channel (11) and actuates the detonator assembly (9). When set for instantaneous action, setback causes the arming sleeve (7) to move rearward and over the safety ring (8), compressing the arming spring (6), and temporarily holding the split safety ring (8) closed; this action prevents the split safety ring from opening to release the detonator assembly for forward movement while the round is in the bore of the weapon. After the projectile leaves the bore, the arming spring (6) lifts the arming spring upward, making it possible for the split safety ring (8) to spread apart (by centrifugal force) and free the detonator assembly (9) for forward movement. On impact with the target, the detonator moves forward and strikes the impact striker (5) and the explosive train is actuated. When set for canister, the time rings (3 and 4) are lined up and the flash from the primer (1), after burning through the

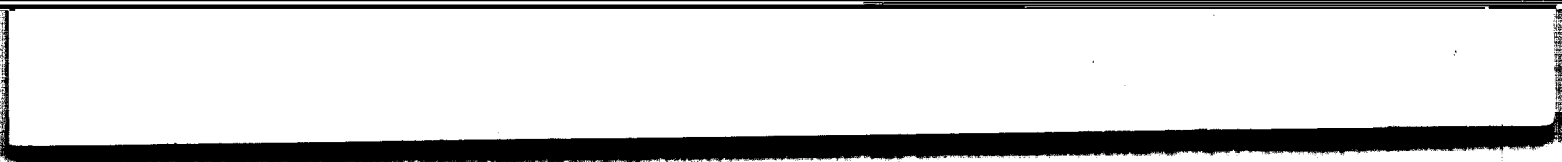
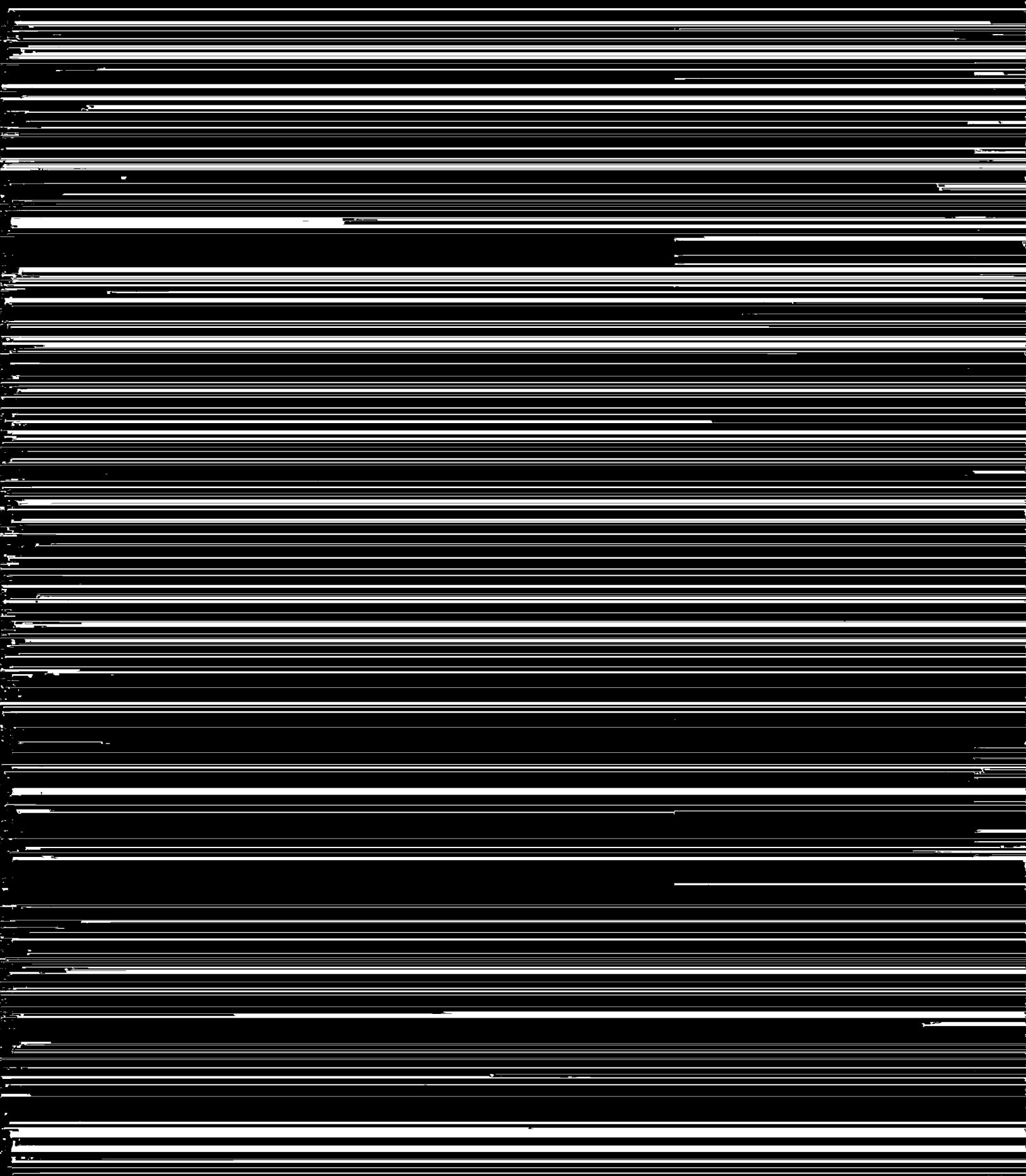

SOVIET POINT DETONATING COMBINATION FUZE MODEL 22P

a. General. Except that it differs slightly in the arming safety arrangement, the 22P fuze is virtually identical to the 22G.

b. Weapons and projectiles with which used.

Weapons	Projectiles
76-mm: divisional guns M1902/30, M1936 (F-22), M1939 (USV), and M1942 (ZIS-3)	76-mm Shrapnel - Sh-354; Sh-354G; Sh-354U Incendiary ----- Z-354

and M1938, divisional guns  
M1902/30, M1936 (F-22), M1939  
(USV), and M1942 (ZIS-3); regi-  
mental gun (howitzer) M1927

overcome the resistance of the spring (2) and strike the primer (3). The flash from the primer travels through the upper flash channel and ignites the powder train in the upper time ring (4) which burns successively through the middle time ring (5) and lower time ring (6). The flash from the lower time ring passes through the flash channel (7) and ignites the powder magazine (8) which in turn explodes the projectile.

d. Weapons and projectiles with which used.

Information on this subject is not available.

8-34

channel holes in all three rings with the channel (15) and the flame jet passes directly to the detonator (9) without passing around the time rings.

SOVIET POINT DETONATING COMBINATION FUZE MODEL 45-SEC

(3) Impact (nondelay). The setting of "УД" blocks the flame holes in the time rings and upon firing, setback forces the impact stirrup (5) rearward, over the impact primer carrier (8) and retainer (7) where it is held during the flight of the projectile. On impact, carrier (8) and stirrup (5) go forward, overcoming the resistance of the retainer (7) and the anticreep spring. The impact primer (6) is ignited by the firing pin (4) and activates the detonator (10) which in turn actuates the time detonator (9). The flame jet then passes through the hole in the plug (16) into the burster tube of the projectile or, in the case of a conventional shrapnel shell, into the detonator-booster.

d. Weapons and projectiles with which used.

Weapons	Projectiles
107-mm: corps guns M1910/30, M1940 (M-60), and M1941	107-mm Shrapnel ----- Sh-422
122-mm: howitzers M1910/30, M1909/37, and M1938 (M330)	122-mm Shrapnel ----- Sh-460
152-mm: howitzers M1909/30, M1938 (M-10), and M1943 (D-1)	152-mm Shrapnel ----- Sh-501

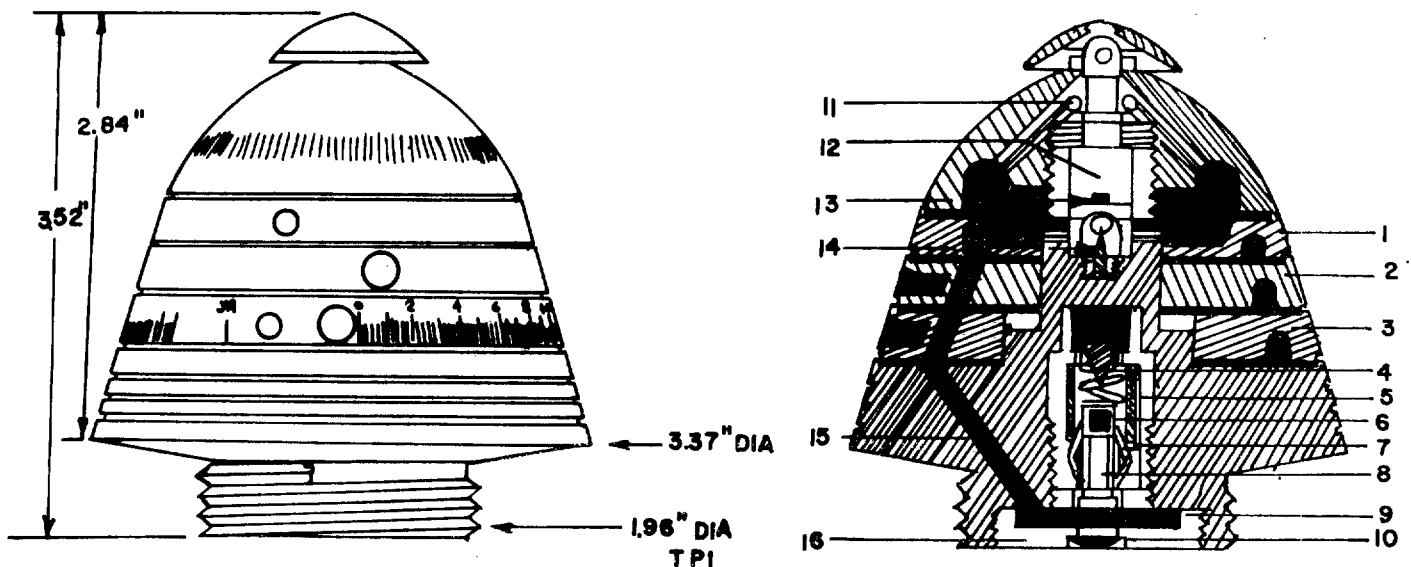

9-1.1

## MISCELLANEOUS FUZES

This chapter includes those fuzes that do not, by definition, fit securely in the other sections of this document. However, these fuzes are no less important than those residing in conventional classification.

A case in point is the Long Delay Fuze, NNC-32. This fuze holds a unique position in the worlds explosive ordnance in that it is the only known long delay fuze employed with projected munitions. Employment of the fuze has been limited, but the threat the fuze presents is real.

The NNC is bore safe, well constructed and unique in that it arms only upon impact. By American standards its only disadvantage is its lack of detonator safety.

The NVA/VC air burst fuze is an interim attempt to fill a void in their ordnance family. They currently lack a fuze for use in infantry weapons that will produce air bursts for anti-personnel or antiaircraft purposes. It is expected that additional fuzes of this classification will appear.

Since the Vietnamese conflict may be classed, in some stages, as a clandestine guerrilla war, it can be assumed that additional special purpose fuzes will be developed that will reside in the miscellaneous classification.

the nose cap is held to the M-6 fuze. The firing pin housing (13) contains the firing pin (14) and spring. The locking balls (4) lock the firing pin (14) in the cocked position. The firing pin housing threads into the delay housing (15). The delay housing (15) contains a rifle primer (7) and safety fuze (8) with a burning time of 2.5 to 3.0 seconds. This time may be varied during manufacture of the fuze. The detonator holder (9) fits inside the delay housing (15) and contains the modified M-6 fuze detonator. The firing pin housing (13) and the delay housing (15) are the ridged elements of the fuze. They are locked into position by the booster adapter (11). The booster (12) is the conventional M-6 fuze booster

b. Characteristics.

Action ----- air burst  
 Loaded weight ----- ?  
 Body material ----- Plastic

c. Functioning. Upon firing, the setback sleeve (3) moves rearward compressing its spring. The ball (2) falls into the ogive cavity. When the compressed setback spring overcomes the forces of acceleration, it forces the setback sleeve (3) upward into the space formally occupied by the ball (2). This uncovers the locking ball recess. The locking balls are cammed out of their recess by the cocked firing pin (14). This releases the firing pin which strikes the primer. The primer (7) flashes, igniting the safety fuze (8) which burns for 2.5 to 3.0 seconds. Upon safety fuze burnout, flame initiates the detonator (10), which functions the booster. The height of burst is dependent entirely upon the number of increments employed on the projectile and the angle of the mortar tube.

d. Weapons and projectiles with which used.

Weapons	Projectiles
Soviet or ChiCom 82-mm mortars	82-mm HE-Frag - Soviet or ChiCom

9-2

of the ampule cavity (22). The delay element support (8) rests under the body washer (6). The firing mechanism housing (15) is the rigid support for all fuze components. It threads into the bottom of the main fuze body and has recesses for the locking balls (11) and an annular groove for the balls to fall into. The two 0.25 inch locking balls (11) positively lock the striker (12) until impact frees them. The locking balls (11) are further retained in their recesses by a brass impact arming collar (13). The collar is maintained in the rear position by the impact arming spring (7).

9-4

NORTH VIETNAMESE CHEMICAL LONG DELAY FUZE MODEL NNC 82

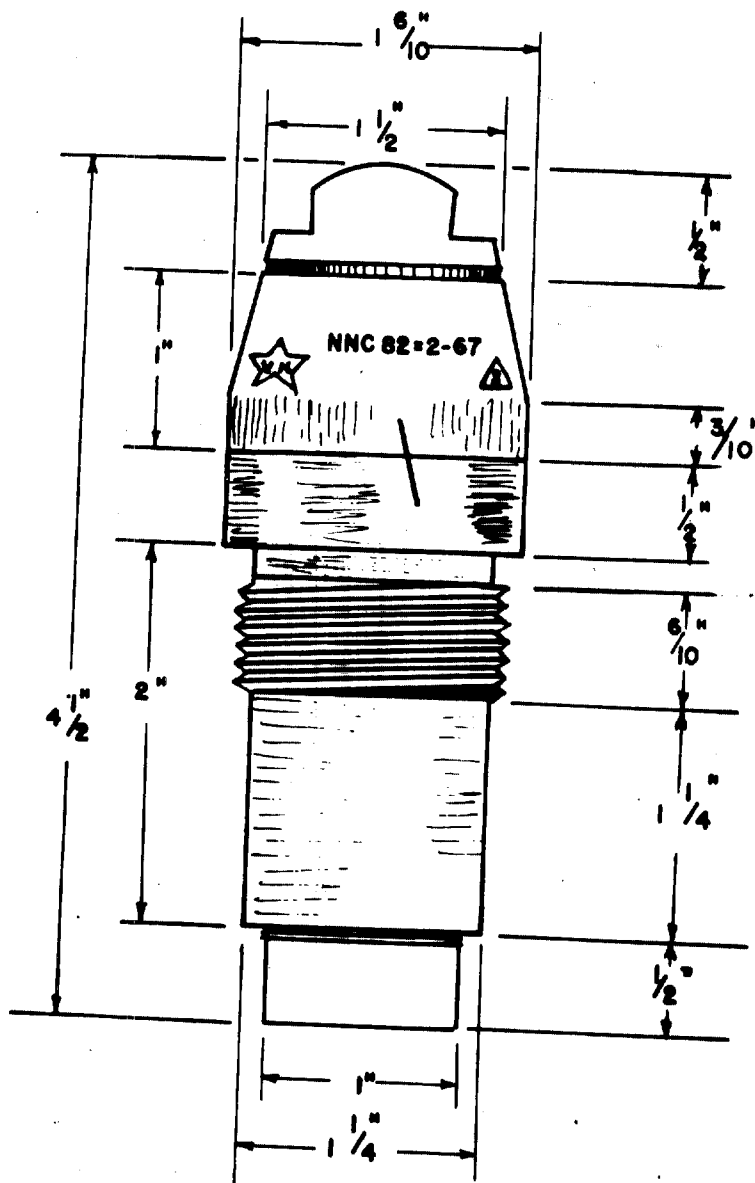

NORTH VIETNAMESE CHEMICAL LONG DELAY FUZE MODEL NNC 82

