

PEOPLE'S SOCIALIST REPUBLIC OF ALBANIA
PEOPLE'S MINISTER OF DEFENCE

THE MUNITIONS HANDBOOK
SPECIFICATIONS AND INFORMATION FOR THE USE OF MUNITIONS

for internal use

TIRANA 1983

**Produced by Turabi Bebeçi, Engineer
The drawings were made by Jani Beba, Engineer
and partly by Gani Mema, Engineer**

"LET US KEEP OUR POWDER DRY AT ALL TIMES, IN ORDER TO MAKE OUR BELOVED ALBANIA STRONGER AND MORE INVOLABLE AGAINST EVERY ENEMY"

ENVER HOXHA

PREFACE

Knowledge of the construction of munitions and of the regulations for the preparation of munitions for firing is essential for their safe and effective use on the battlefield. On the other hand munitions are objects which lose their military effectiveness with the passage of time, and ultimately have an expiry date. The period during which munitions can be used until they reach their expiry date depends to a great extent on the conditions under which they are stored and maintained, and can, if continuous attention is paid, be greatly prolonged. It is also well-known that sustained firing with munitions from one production batch ensures the most effective spread of strikes, and effectively saves ammunition, because each batch of ammunition has different ballistic characteristics. From this arise two most important requirements:

- a. The rigorous implementation of the criteria for expending the oldest ammunition, and
- b. The timely laboratory analysis of each batch of gunpowder.

Failure to implement these two requirements can lead to the gunpowder's reaching the phase of intensive decomposition and if the relevant munitions cannot be identified and separated in time, then self-detonation can result. The basic condition for the complete and correct implementation of the criterion of expending the oldest ammunition and the timely carrying out of laboratory analysis is the storage and administration of munitions by production batch.

From what is said above it will be understood that the precise knowledge of the types of munitions, of their preparation for and use during firing, and of the details of production of munitions is essential to the implementation of the requirements of the People's Military Manual for strict economy in the use of munitions.

This manual detailing specifications of and directions for the use of munitions, which contains technical details of all types of artillery munitions – field, anti-aircraft and coastal, tank and SPG munitions, and munitions for Aircraft cannon and naval guns - has the specific purpose of providing a basic reference work for our armed forces, from which they can study and extract the necessary information about the munitions used in their arms of service and units. By means of the explanations of the codes used for the indicators, tables, and figures provided in this text, the identification and method of use of munitions can be established.

For this purpose it is necessary for the contents of the text to be studied, and above all Chapter I, in which the most essential explanations are given about the construction of the various types of artillery rounds, and of their constituent parts. In this chapter there are set out in detail the methods of decoding the indicators and the distinguishing colours of munitions. The meaning of the letters and various symbols of the indicators on munitions produced by ourselves, Russia or China is shown in special accompanying tables.

In Chapters II-IX the types of munitions used in various weapons are set out, together with their constituent parts and principal data. For the weight and dimensions of munitions, nominal (average) figures are given, because it is known that these can vary within specified limits within the technical conditions of production. For shells the weight is given together with that of the fuze.

In Chapter X the types, characteristics and use of fuzes are set out.

In Part II (Illustrations) the drawings of the munitions are presented in two views, a cross-section to show the internal construction, and an exterior view to show the indicators on the munition (principally their indices.) Two numbers are shown against each drawing; the first of these indicating the chapter in which the munition shown is covered, while the other is the serial number of the drawing. Thus for example the drawings with 2 as their first number (e.g. 2-1, 2-2 etc.) are munitions covered in Chapter II, while those with 3 as their first number are covered in Chapter III, and so on. In order to show the construction of weapons as clearly as possible, they are drawn to different scales. Accordingly to enable the user of this work to visualise the actual size from the drawings the length of the rounds, shells and cases has been given in millimetres.

PREFACE

SECTION ONE

1. Types and construction of artillery munitions
2. The principles of location of indicators on munitions and key to these.
3. Colour coding of munitions

CHAPTER II

MUNITIONS FOR ARTILLERY WEAPONS

- I. MUNITIONS FOR 23 mm. AIRCRAFT CANNON (FIGURES 2-1 AND 2-2)
- II. MUNITIONS FOR 25 mm. AA GUN MODEL 1940 (SEE FIGURES No. 2-3 and 2-4)
- III. MUNITIONS FOR 25 mm. NAVAL GUN (FIGURE No. 2-5)
- IV. MUNITIONS FOR 30 mm. AIRCRAFT CANNON (FIGURES 2-6 TO 2-8)
- V. MUNITIONS FOR 37 mm. AIRCRAFT CANNON (FIGURES 2-9 AND 2-10)
- VI. MUNITIONS FOR 37 mm. GUNS (SINGLE BARREL 37 mm. AA GUN 1939 AND 1955 MODELS AND TWIN BARREL 1965 MODEL AND 37 mm. NAVAL GUN) (FIGURES 2-11 AND 2-12)

- VII. MUNITIONS FOR 45 mm. GUNS (45 mm. ANTI-TANK GUN 1937 AND 1942 MODELS AND 45 mm. NAVAL GUN (FIGURES 2-13 TO 2-18.))
- VIII. MUNITIONS FOR 57 mm. AA GUN, 1958 MODEL (FIGURES 2-19 AND 2-20)
- IX. MUNITIONS FOR 76 mm. GUNS (76 mm. FIELD GUN 1942 MODEL (MOD 54) 76 mm. SP GUN AND 76 mm. REGIMENTAL GUN 1943 MODEL) (FIGURES 2-21 TO 2-30)
- X. MUNITIONS FOR 85 mm. GUNS (85 mm. FIELD GUN 1956 MODEL, 85 mm. TANK-MOUNTED GUN , 85 mm. AA GUN 1939 MODEL AND 85 mm. NAVAL GUN) (FIGURES 2-31 TO 2-38)
- XI. MUNITIONS FOR 100 mm. GUNS (100 mm. FIELD GUN 1954 MODEL (1944); 100 mm. AA GUN 1959 MODEL, 100 mm. TANK-MOUNTED AND SP GUN, 100 mm. COASTAL ARTILLERY GUN WITH MECHANICAL EXTRACTION) (FIGURES 2-39 TO 2-48.)
- XII. MUNITIONS USED IN 122 mm. HOWITZER 1954 MODEL (1938) (FIGURES 2-49 TO 2-58)
- XIII. MUNITIONS FOR 122 mm. GUN 1960 MODEL. (FIGURES 2-59 TO 2-61)
- XIV. MUNITIONS FOR 130 MM. COASTAL ARTILLERY GUN WITH MECHANICAL EXTRACTION (FIGURES 2-62 TO 2-66).
- XV. MUNITIONS FOR 130 mm. COASTAL ARTILLERY GUN (SEPARATE-LOADING) (FIGURES 2-67 TO 2-70)
- XVI. MUNITIONS FOR 130 mm. FIELD GUN (1959 AND 1959-1MODELS) (FIGURES 2-71 TO 2-74)
- XVII. MUNITIONS FOR 152 mm. GUN AND GUN-HOWITZER (FIGURES 2-75 TO 2-87)

CHAPTER III

MUNITIONS FOR RECOILLESS GUNS

- I. MUNITIONS FOR 75mm. RECOILLESS GUNS, 1956 AND 1956-2 MODELS (FIGURES 3-1 AND 3-2)
- II. MUNITIONS FOR 82 mm. RECOILLESS GUN MODEL B-10 (FIGURES 3-3 TO 3-5)
- III. MUNITIONS FOR 107 mm. RECOILLESS GUN MODEL B-11 (FIGURES 3-6 TO 3-9)

CHAPTER IV

MUNITIONS FOR GRENADE LAUNCHERS

- 40 mm. grenade launcher (light) (56 model and 1969 model) (Figures 4-1 to 4-4)

CHAPTER V.

MORTAR MUNITIONS

- I. MUNITIONS FOR 60 mm. MORTAR MODEL 63 (FIGURES 5-1 AND 5-2)
- II. MUNITIONS FOR 82 mm. MORTARS, (1937, 1941, 1943 AND 1953 MODELS)(FIGURES 5-3 TO5-6)
- III. MUNITIONS FOR 107 mm. MORTAR (1938 MODEL) (FIGURES 5-7 AND 5-8)
- IV. MUNITIONS FOR 120 mm. MORTAR (1938, 1945 AND 1955 MODELS) (FIGURES 5-9 TO 5-12)
- V. MUNITIONS FOR 160 mm. MORTAR (1956 MODEL) (FIGURES 5-13 AND 5-14)

CHAPTER VI.

BARREL LAUNCHED ROCKETS

(107 mm. rocket launcher (1963 model) 130 mm. rocket launcher SP rocket launcher (1963 model) and ML –13 SP rocket launcher (Figures 6-1 to 6-3)

CHAPTER VII.

SMALL ARMS AMMUNITION: PISTOLS, RIFLES, AUTOMATIC RIFLES, LIGHT AND HEAVY MACHINE GUNS AND AA MACHINE GUNS (FIGURES 7-1 TO 7-20)

Pistol rounds

Rounds for 7.62 mm. weapons (56 model): (automatic rifle, rifle, and light machine gun)

Rounds for 7.62 mm. weapons (53 model): (rifle, and light and heavy machine guns)

12.7 mm. rounds

14.5 mm. rounds

CHAPTER VIII.

HAND GRENADES (FIGURES 8-1 TO 8-11)

1. ANTI-PERSONNEL HAND GRENADES

2. ANTI-TANK HAND GRENADES

CHAPTER IX.

SIGNAL AND ILLUMINATING ROUNDS (FIGURES 9-1 TO 9/7)

CHAPTER X.

CHARACTERISTICS AND USE OF SHELL FUZES

1. Fuzes for mortar bombs

2. Fuzes for ground artillery shells

3. Fuzes for AA artillery and aircraft cannon shells

4. Fuzes for shells for recoilless guns, reactive weapons and grenade launchers

PART II

DRAWINGS OF MUNITIONS FOR ARTILLERY WEAPONS WITH RIFLED BARRELS

Figure 2-1 Round for 23 mm. aircraft cannon with fragmentation-incendiary-tracer shell.

Figure 2-2 Round for 23 mm. aircraft cannon with AP incendiary shell.

Figure 2-3 Round with fragmentation tracer shell for 25 mm. AA gun.

Figure 2-4 Round with AP tracer shell for 25 mm. AA gun.

Figure 2-5 Round for 25 mm. naval gun with fragmentation incendiary tracer shell.

Figure 2-6 Round for 30 mm. aircraft cannon with fragmentation incendiary shell.

Figure 2-7 Round for 30 mm. aircraft cannon with fragmentation incendiary tracer shell.

[Figure 2-8](#) [Round for 30 mm. aircraft cannon with AP tracer shell.](#)
[Figure 2-9](#) [Round for 37 mm. aircraft cannon with fragmentation incendiary tracer shell.](#)
[Figure 2-10](#) [Round for 37 mm. aircraft cannon with AP incendiary tracer shell.](#)
[Figure 2-11](#) [Round for 37 mm. AA gun with fragmentation tracer shell.](#)
[Figure 2-13](#) [45 mm. round with short range fragmentation shell.](#)
[Figure 2-14](#) [45 mm. round with AP tracer shell.](#)
[Figure 2-15](#) [45 mm. round with AP incendiary tracer shell.](#)
[Figure 2-16](#) [45 mm. round with AP sub-calibre shell.](#)
[Figure 2-17](#) [45 mm. round with AA fragmentation shell for naval gun.](#)
[Figure 2-18](#) [45 mm. round with practice tracer shell](#)
[Figure 2-19](#) [Round for 57 mm. AA gun with fragmentation tracer shell.](#)
[Figure 2-20](#) [Round for 57 mm. AA gun with AP tracer shell.](#)
[Figure 2-21](#) [Round for 76 mm. regimental gun \(model 43\) with fragmentation shell.](#)
[Figure 2-22](#) [Round for 76 mm. regimental gun \(model 43\) with HE-fragmentation shell.](#)
[Figure 2-23](#) [Round for 76 mm. regimental gun \(model 43\) with shaped charge shell.](#)
[Figure 2-24](#) [Round for 76 mm. field and SP guns with fragmentation shell.](#)
[Figure 2-25](#) [Round for 76 mm. field and SP guns with fragmentation shell \(reduced charge.\)](#)
[Figure 2-26](#) [Round for 76 mm. field and SP guns with HE-fragmentation shell.](#)
[Figure 2-27](#) [Round for 76 mm. field and SP guns with AP shell shaped as illustrated.](#)
[Figure 2-28](#) [Round for 76 mm. field and SP guns with flat-nosed AP shell.](#)
[Figure 2-29](#) [Round for 76 mm. field and SP guns with solid AP shell \(with ballistic cap\).](#)
[Figure 2-30](#) [Round for 76 mm. field and SP guns with sub-calibre AP shell.](#)
[Figure 2-31](#) [85 mm. round with steel fragmentation shell and full charge.](#)
[Figure 2-32](#) [85 mm. round with steel fragmentation shell and reduced charge.](#)
[Figure 2-33](#) [85 mm. round with cast-iron fragmentation shell and reduced charge.](#)
[Figure 2-34](#) [85 mm. round with AA fragmentation airburst round.](#)
[Figure 2-35](#) [85 mm. round with sharp-nosed AP tracer shell.](#)
[Figure 2-36](#) [85 mm. round with blunt-nosed AP tracer shell with ballistic cap.](#)
[Figure 2-37](#) [85 mm. round with AP tracer shell with AP nose and ballistic cap.](#)
[Figure 2-38](#) [85 mm. round with sub-calibre AP tracer shell.](#)
[Figure 2-39](#) [100 mm. round with full charge and HE fragmentation shell.](#)
[Figure 2-40](#) [100 mm. round with reduced charge and HE fragmentation shell.](#)
[Figure 2-41](#) [100 mm. round with blunt-nosed AP tracer shell and ballistic cap.](#)
[Figure 2-42](#) [100 mm. round with sharp-nosed AP tracer shell.](#)
[Figure 2-43](#) [100 mm. round with reduced charge and practice tracer shell.](#)
[Figure 2-44](#) [Round for 100 mm. AA gun with fragmentation airburst shell.](#)

[Figure 2-45](#) [Round for 100 mm. coastal artillery gun \(mechanical extraction\) with full charge and HE shell.](#)
[Figure 2-46](#) [Round for 100 mm. coastal artillery gun\(mechanical extraction\) with full charge and fragmentation airburst shell.](#)
[Figure 2-47](#) [Round for 100 mm. coastal artillery gun \(mechanical extraction\) with reduced charge and practice shell.](#)
[Figure 2-48](#) [Round for 100 mm. coastal artillery gun \(mechanical extraction\) with illuminating shell.](#)
[Figure 2-49](#) [122 mm. HE-fragmentation shell for model 54 \(38\) howitzer.](#)
[Figure 2-50](#) [Cast-iron one-piece fragmentation shell for 122 mm. howitzer model 54 \(38\).](#)
[Figure 2-51](#) [Cast-iron fragmentation shell howitzer with screwed-in nose-piece for 122 mm. howitzer model 54 \(38\).](#)
[Figure 2-52](#) [Cast-iron shaped charge shell for 122 mm. howitzer model 54 \(38\).](#)
[Figure 2-53](#) [Steel shaped charge shell for 122 mm. howitzer model 54 \(38\).](#)
[Figure 2-54](#) [Steel smoke shell for 122 mm. howitzer model 54 \(38\).122 mm.](#)
[Figure 2-55](#) [Cast-iron smoke shell for 122 mm. howitzer model 54 \(38\).](#)
[Figure 2-56](#) [Illuminating shell \(index No. S-463\) for 122 mm. howitzer model 54 \(38\).](#)
[Figure 2-57](#) [Illuminating shell \(index No. S-462.\) for 122 mm. howitzer model 54 \(38\).](#)
[Figure 2-58](#) [Propellant \(full charge\) for 122 mm. howitzer.](#)
[Figure 2-59](#) [HE-fragmentation shell for 122 mm. howitzer 1960 model.](#)
[Figure 2-60](#) [Propellant \(full charge\) for 122 mm. howitzer 1960 model.](#)
[Figure 2-61](#) [Propellant \(reduced charge\) for 122 mm. howitzer 1960 model.](#)
[Figure 2-62](#) [Semi-AP shell for 130 mm. coastal artillery gun \(mechanical extraction.\)](#)
[Figure 2-63](#) [HE-fragmentation shell for 130 mm. coastal artillery gun \(mechanical extraction.\)](#)
[Figure 2-64](#) [Fragmentation airburst \(AA\) shell for 130 mm coastal artillery gun \(mechanical extraction.\)](#)
[Figure 2-65](#) [Propellant \(full charge\) for 130 mm. coastal artillery gun \(mechanical extraction.\)](#)
[Figure 2-66](#) [Propellant \(reduced charge\) for 130 mm coastal artillery gun \(mechanical extraction.\)](#)
[Figure 2-67](#) [HE-fragmentation shell for 130 mm. coastal artillery gun \(separate loading.\)](#)
[Figure 2-68](#) [Semi-AP shell for 130 mm. coastal artillery gun \(separate loading.\)](#)
[Figure 2-69](#) [Propellant \(full charge\) for 130 mm. coastal artillery gun \(separate loading.\)](#)
[Figure 2-70](#) [Propellant \(reduced charge\) for 130 mm. coastal artillery gun \(separate loading.\)](#)
[Figure 2-71](#) [HE-fragmentation shell for 130 mm. field gun model 1959.](#)
[Figure 2-72](#) [Practice shell for 130 mm. field gun model 1959.](#)
[Figure 2-73](#) [Propellant \(reduced charge\) for 130 mm. field gun model 1959.](#)
[Figure 2-74](#) [Propellant \(full charge\) for 130 mm. field gun model 1959.](#)
[Figure 2-75](#) [Steel HE-fragmentation shell for 152 mm. howitzer.](#)
[Figure 2-76](#) [Cast-iron fragmentation shell for 152 mm. howitzer.](#)
[Figure 2-77](#) [Concrete-piercing shell for 152 mm. howitzer.](#)
[Figure 2-78](#) [HE-fragmentation shell for 152 mm. gun-howitzer.](#)
[Figure 2-79](#) [AP shell for 152 mm. gun-howitzer.](#)
[Figure 2-80](#) [Propellant \(full charge\) for 152 mm. howitzer.](#)

- Figure 2-81 Propellant (full charge) for 152 mm. gun-howitzer model 1966.
- Figure 2-82 Propellant (Charge no. 2) for 152 mm. gun-howitzer model 1966.
- Figure 2-83 Propellant (full charge) (Index No. Zh-545) for 152 mm. gun-howitzer model 1937.
- Figure 2-84 Propellant (full charge) (Index No. ZHN-545) for 152 mm. gun-howitzer model 1937.
- Figure 2-85 Propellant (reduced charge) (Index No. Zh-545U) for 152 mm. gun-howitzer model 1937.
- Figure 2-86 Propellant (reduced charge) (Index No. ZHN-545U) for 152 mm. gun-howitzer model 1937.
- Figure 2-87 Propellant (special charge) for 152 mm. gun-howitzer model 1937.
- Figure 2-88 ZTN primer.
- Figure 2-89 KV-2 primer.
- Figure 2-90 KV-4 primer
- Figure 2-91 KV-5 primer.
- Figure 2-92 KV-13 primer.
- Figure 2-93 UT-36 mechanical primer for charges used in 130 mm. coastal artillery gun (separate loading.)
- Figure 2-94 GT-2 electrical primer for charges used in 130 mm. coastal artillery gun (separate loading.)

PART III

DRAWINGS OF MUNITIONS FOR RECOILLESS GUNS

- Figure 3-1 75 mm. recoilless gun round with fragmentation shell.
- Figure 3-2 75 mm. recoilless gun round with shaped charge shell.
- Figure 3-3 82 mm. recoilless gun round with fragmentation shell.
- Figure 3-4 82 mm. recoilless gun round with shaped charge shell.
- Figure 3-5 82 mm. recoilless gun round with practice shell.
- Figure 3-6 Components of rounds for 107 mm. recoilless gun.
- Figure 3-7 Round for 107 mm. recoilless gun with shaped charge shell.
- Figure 3-8 Round for 107 mm. recoilless gun with HE-fragmentation shell.
- Figure 3-9 Round for 107 mm. recoilless gun with practice shell.
- Figure 3-10 Construction of primer cartridge for recoilless gun propellant charges.
- Figure 3-11 Method of packing recoilless rounds in container and box.

PART IV

DRAWINGS OF GRANADE LAUNCHER MUNITIONS

- Figure 4-1 Shape charge projectile for 40 mm Granade Launcher (Light) Model 56
- Figure 4-2 Components of shape charge projectile for 40 mm Granade Launcher (Light) Model 56
- Figure 4-3 Method of placing wire ring over stabiliser fins of shape charge projectile for 40 mm Granade Launcher (Light) Model 56
- Figure 4-4 In the drawings items 1.8 appear above the words contact part of fuze

PART V

DRAWINGS OF MORTAR MUNITIONS

- Figure 5-1 Eight-finned fragmentation bomb for 60 mm. mortar.
- Figure 5-2 Ten-finned fragmentation bomb for 60 mm. mortar.
- Figure 5-3 Ten-finned fragmentation bomb for 82 mm. mortar.
- Figure 5-4 Six-finned fragmentation bomb for 82 mm. mortar.
- Figure 5-5 Additional annular nitro-cellulose (Pyroxiline) charge for propellant charge for 82 mm. mortar; Positioning of this in the projectile.
- Figure 5-6 82 mm. mortar bomb – illuminating.
- Figure 5-7 Cast-iron HE-fragmentation bomb for 107 mm. mortar.
- Figure 5-8 Steel HE-fragmentation bomb for 107 mm. mortar.
- Figure 5-9 Cast-iron HE-fragmentation bomb for 120 mm. mortar.
- Figure 5-10 Steel HE-fragmentation bomb for 120 mm. mortar.
- Figure 5-11 Smoke bomb for 120 mm. mortar.
- Figure 5-12 Incendiary bomb for 120 mm. mortar.
- Figure 5-13 Steel HE bomb with long-range charge for 160 mm. mortar.
- Figure 5-14 Cast-iron HE bomb with variable charge for 160 mm. mortar.

PART VI

DRAWINGS OF ROCKETS

- Figure 6-1 View of components of rockets for 107 mm. and 130 mm. model 63 rocket launchers.
- Figure 6-2 HE-fragmentation rocket for 107 mm. rocket launcher model 63 with primer placed behind rocket.
- Figure 6-1. HE-fragmentation rocket for 107 mm. rocket launcher model 63 with primer adjacent to turbine.
- Figure 6-4 HE-fragmentation rocket for 130 mm. rocket launcher model 63.
- Figure 6-5 HE-fragmentation rocket for 130 mm. ML-13 launcher.

PART VII

DRAWINGS OF SMALL-ARMS MUNITIONS

- Figure 7-1 7.62 mm. round for pistol and automatic rifle model 54.
- Figure 7-2 7.62 mm. round for Nagant revolver.
- Figure 7-3 9 mm. round for pistol model 1959.
- Figure 7-4 7.62 round with standard bullet
- Figure 7-5 7.62 bullet with tracer bullet.
- Figure 7-6 7.62 round model 56 with AP- incendiary bullet.
- Figure 7-7 7.62 round model 56 with incendiary bullet.
- Figure 7-8 7.62 exercise [BLANK] round model 56.
- Figure 7-9 7.62 round model 53 with lightweight bullet.
- Figure 7-10 7.62 round model 53 with heavyweight bullet.
- Figure 7-11 7.62 round model 53 with AP-incendiary bullet.
- Figure 7-12 7.62 round model 53 with tracer bullet.
- Figure 7-13 7.62 round model 53 with incendiary tracer bullet.
- Figure 7-14 Model 53 round with lightweight bullet with steel core.
- Figure 7-15 7.62 mm. Exercise [BLANK] round model 53.
- Figure 7-16 12.7 mm. round with AP-incendiary bullet.
- Figure 7-17 12.7 mm. round with AP-incendiary-tracer bullet.
- Figure 7-18 14.5 mm. round with AP-incendiary bullet.
- Figure 7-19 14.5 mm. round with AP-incendiary bullet with special core.
- Figure 7-20 14.5 mm. round with AP-incendiary-tracer bullet.
- Figure 7-21 14.5 mm. round with incendiary bullet.

PART VIII

DRAWINGS OF HAND GRENADES

- Figure 8-1 Assault hand grenade model 42.
- Figure 8-2 Assault hand grenade model 59.
- Figure 8-3 Defensive hand grenade.
- Figure 8-4 Design of the one-piece primer for hand grenades (This primer is used in the assault hand grenades models 42 and 59, and in the defensive grenade model F-1.)
- Figure 8-5 Assault hand grenade with wooden stick.
- Figure 8-6. Assault Hand Grenade with wooden stick

- Figure 8-7 Anti-tank hand grenade model 43.
- Figure 8-8 Anti-tank hand grenade model 6.
- Figure 8-9 Anti-tank hand grenade model 3 (external view.)
- Figure 8-10 Handle of anti-tank hand grenade model 3.
- Figure 8-11 Body of anti-tank hand grenade model 3.

PART IX

DRAWINGS OF SIGNAL AND ILLUMINATING ROUNDS

- Figure 9-1 Design of 26 mm. night signalling round.
- Figure 9-2 Design of 26 mm. daylight signalling round.
- Figure 9-3 26 mm. night signalling rounds.
- Figure 9-4 26 mm. night signalling rounds.
- Figure 9-5 26 mm. daylight signalling round.
- Figure 9-6 26 mm. daylight signalling round (red.)
- Figure 9-7 40 mm. illuminating rocket.

PART X

DRAWINGS OF FUZES

- Figure 10-1 M-5 Fuze.
- Figure 10-2 GVMZ-1 Fuze.
- Figure 10-3 GVMZ-7 Fuze.
- Figure 10-4 M-12 Fuze.
- Figure 10-5 M-6 Fuze.
- Figure 10-6 K-107 Fuze.
- Figure 10-7 T-1 Fuze.
- Figure 10-8 KTM-1 Fuze.
- Figure 10-9 KTM-1U Fuze.
- Figure 10-10 KTMZ-1U Fuze.
- Figure 10-11 KTM-2 Fuze.
- Figure 10-12 MGN Fuze.
- Figure 10-13 RGM Fuze.
- Figure 10-14 RGM-2 Fuze.
- Figure 10-15 RGM-6 Fuze.

Figure 10-16 V-429 Fuze.
Figure 10-17 D-1U Fuze.
Figure 10-18 BM Fuze.
Figure 10-19 V-229 Fuze.
Figure 10-20 GKV Fuze.
Figure 10-21 VGU-1 Fuze.
Figure 10-22 T-6 Fuze.
Figure 10-24 VM-16 Fuze.
Figure 10-25 VM-60 Fuze.
Figure 10-26 MD-5 Fuze.
Figure 10-27 MD-7 Fuze.
Figure 10-28 MD-8 Fuze.
Figure 10-29 2-MR Fuze.
Figure 10-30 ZMR Fuze.
Figure 10-31 V-350 Fuze.
Figure 10-32 KTD Fuze.
Figure 10-33 K-20 Fuze.
Figure 10-34 A-23 Fuze.
Figure 10-35 B-23 Fuze.
Figure 10-36 A-30 Fuze.
Figure 10-37 30-1 Fuze.
Figure 10-38 A-37 Fuze.
Figure 10-39 MG-37 Fuze.
Figure 10-40 MG-57 Fuze.
Figure 10-41 MD-10 Fuze.
Figure 10-42 T-5 Fuze.
Figure 10-43 VM-30 Fuze.
Figure 10-44 GK-2 Fuze.
Figure 10-45 TS-1 Fuze.
Figure 10-46 K-1 Fuze.
Figure 10-47 DMK Fuze.
Figure 10-48 Fuze for shaped charge shell for 40 mm. grenade launcher (light) model 56.
Figure 10-49 Fuze for shaped charge shell for 40 mm. grenade launcher (light) model 69.

SECTION ONE

COMPONENTS AND USE OF MUNITIONS

CHAPTER I

GENERAL INFORMATION

1.Types and construction of artillery munitions

The set of munitions and other elements which are essential for firing is called a round.

Artillery rounds can be divided according to use into the following categories: combat, blank (simulation) practice and training.

Combat rounds are in general made up of the following components:

1. Shell, with appropriate filling.
2. Fuze.
3. Propellant charge.
4. Case or sac.
5. Primer for the propellant and
6. Auxiliary components of the propellant filling, which may be: primer, flash suppressant, a normal cover, a hermetically sealing cover, a decoppering agent, a phlegmatiser and devices to locate components within the case.

The principal components of each round are the shell and the propellant.

The shell is that part of the round which directly performs the combat function of the artillery. Shells can be of various construction types depending on the targets which they are intended to annihilate or destroy. The following types of shells are used predominantly in artillery firing:

1. **Fragmentation shells** (Fig. 2) for striking enemy personnel and equipment, mainly by means of small fragments.

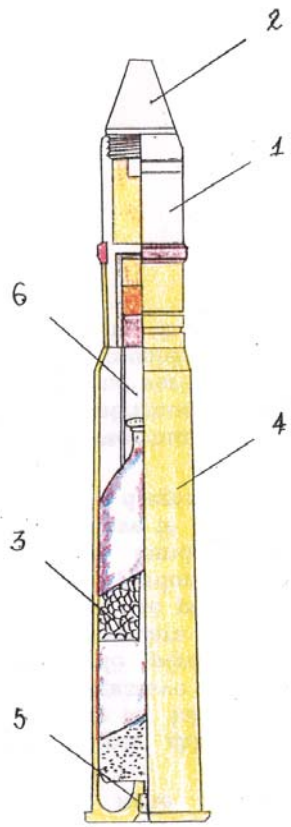

Figure 1. Components of a combat round.

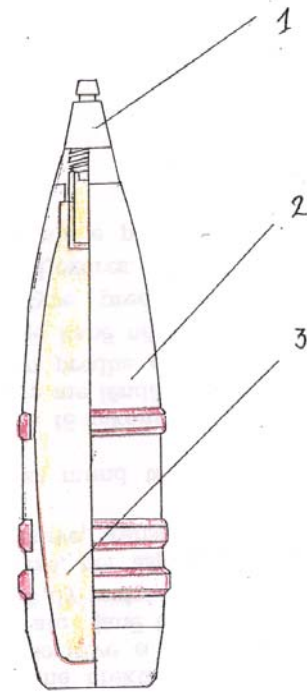

Figure 2. Fragmentation shell.

1. Shell.
2. Fuze
3. Propellant
4. Shell-case.
5. Detonator capsule.
6. Cardboard cylinder.

1. Fuze.
2. Body.
3. Explosive.

1. (continued) These can be used both for the destruction of infantry light defensive works, as well as for the opening of routes through wire obstacles and minefields. In the absence of other munitions, fragmentation shells can also be used against armoured vehicles and gunports in concrete defensive points. Fragmentation shells always have nose-mounted fuzes.

2. **High Explosive (HE) shells** (figure 3) for the destruction of non-concrete fortifications and enemy equipment, mainly from the force of the gas from the HE charge. These shells can be used for the opening of routes through minefields by means of ricochet fire. In the absence of other munitions HE shells can also be used against armoured vehicles, live targets, and concrete fortifications. HE shells can have either nose-mounted or base-mounted fuzes.

3. **HE-fragmentation shells** can be used as HE or as fragmentation shells, depending on the fuze-setting employed. When the fuze of an HE-fragmentation shell is set for immediate activation, the shell functions as a fragmentation shell, whereas when the fuze is set on an inertial or delayed setting, the shell functions as an HE shell. HE-fragmentation shells always have a nose-mounted fuze. In the fragmentation role they produce a slightly less powerful effect than fragmentation shells, likewise when used in an HE role by comparison with HE shells.. The positive side of HE-fragmentation shells is that they represent single shells which can be used in both roles.

4. **Armour-piercing (AP) shells** for the annihilation of armoured targets (tanks, APC's etc). AP shells can be of the following types:

a. **Standard AP shells (Figures 4 & 5)** which are filled with HE and have a base-mounted fuze. These shells pierce the armour with the kinetic energy which they have on impact. They detonate after the delay period to which the fuze has been set. The interval of the delay is calculated so that the explosion of the HE charge occurs after the armour has been pierced.

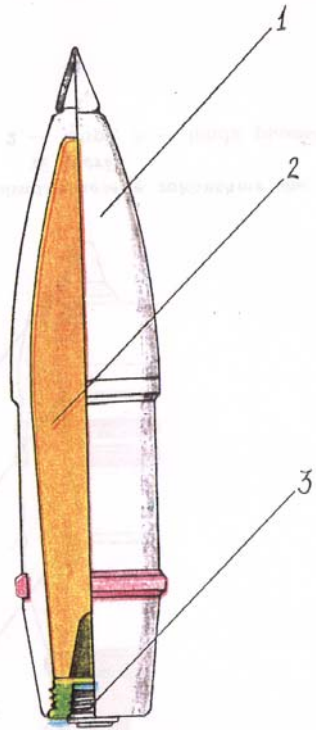

Figure 3. HE shell:
1. Body.
2. Explosive charge.
3. Fuze.

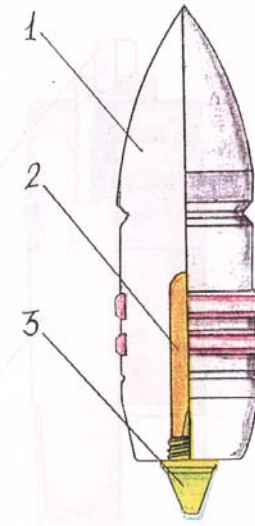

Figure 4. Standard sharp-nosed AP shell:
1. Body.
2. Explosive charge.
3. Fuze.

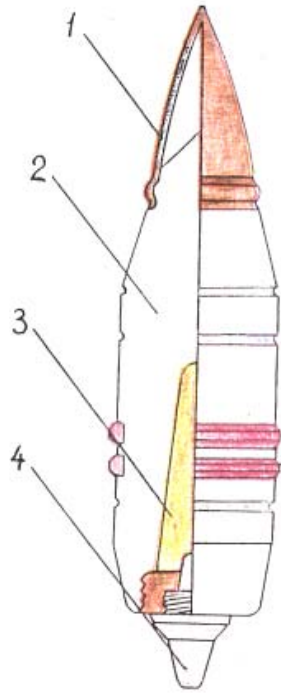

Figure 5. Standard blunt-nosed AP shell:
 1. Ballistic cap.
 2. Body.
 3. Explosive charge.
 4. Fuze.

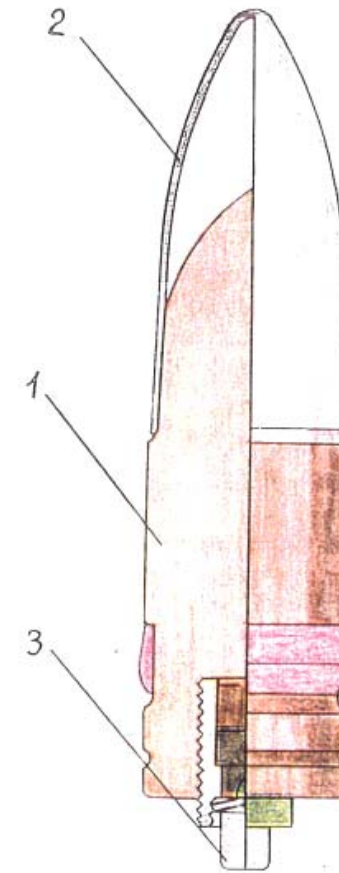

Figure 6. Solid AP shell with ballistic cap
 1. Body
 2. Cap
 3. Tracer.

b. Solid *AP shell with ballistic cap* (Figure 6.)

These shells are not filled with an explosive charge. They pierce armour thanks to the kinetic energy which they possess and after piercing the armour they damage the target with loose fragments and fragments detached from the armour.

c. **Sub-calibre AP shells.** These shells are characterised by the high initial speed which they attain during firing, because they are lighter in weight than other shells (see Figure 7.)

The part which pierces (i.e. the core) of these shells is made of special steel with high penetrative capability. Their external appearance is distinguished by their drum-like form (the central part is smaller in diameter than the gun-barrel.)

Sub-calibre AP shells are more effective at striking heavy AFV's from closer range.

5. **Shaped charge shells** for the destruction of AFV's by means of the concentrated flow of gases. (Figure 8.)

6. **Concrete-piercing shells** for the destruction of concrete fortifications. (Figure 9.)

7. **Incendiary shells** for setting fire to various enemy targets. (Figure 10.)

8. **Canister-shot shells** for destroying personnel detected at short range. (Figure 11.)

9. **Smoke shells** to deprive the enemy of visibility. (Figure 12.)

10. **Illuminating shells** for the illumination of ground and targets by night. (Figure 13.)

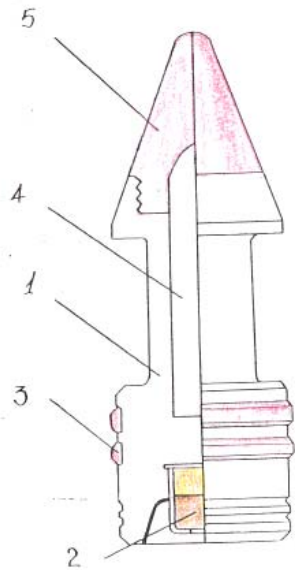

Figure 7. Sub-calibre AP shell

- 1. Body.
- 2. Tracer.
- 3. Driving band.
- 4. Armour-piercing core.
- 5. Cap.

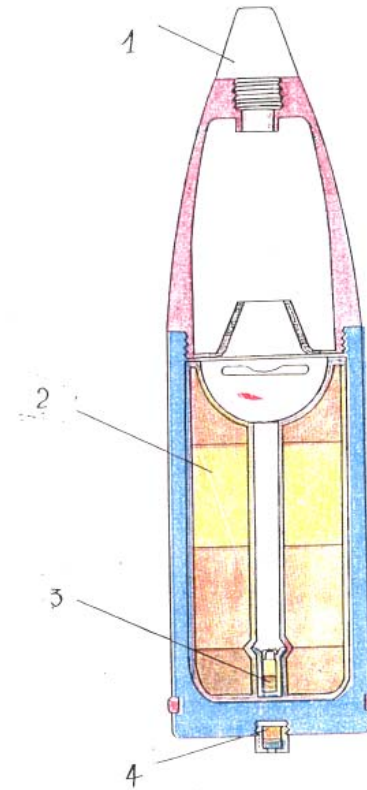

Figure 8. Shaped charge shell

- 1. Fuze
- 2. Explosive charge.
- 3. Detonator capsule.
- 4. Tracer.

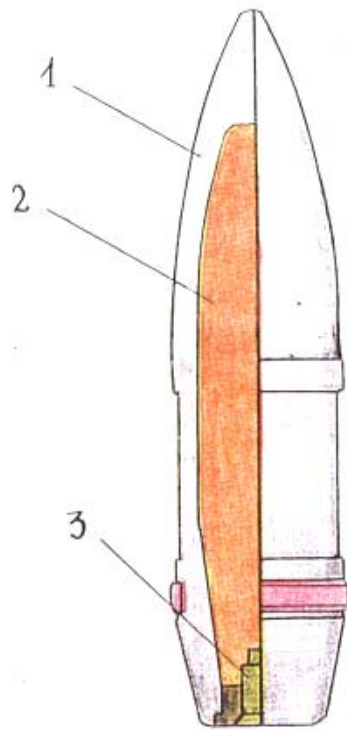

Figure 9. Concrete-piercing shell.

1. Body.
2. Explosive charge.
3. Base-mounted fuze.

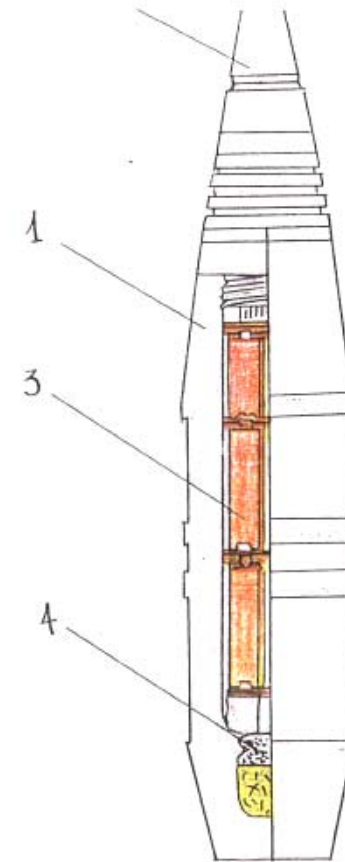

Figure 10. Incendiary shell.

1. Body.
2. Fuze
3. Incendiary material
4. Dispersant filling (gunpowder with smoke.)

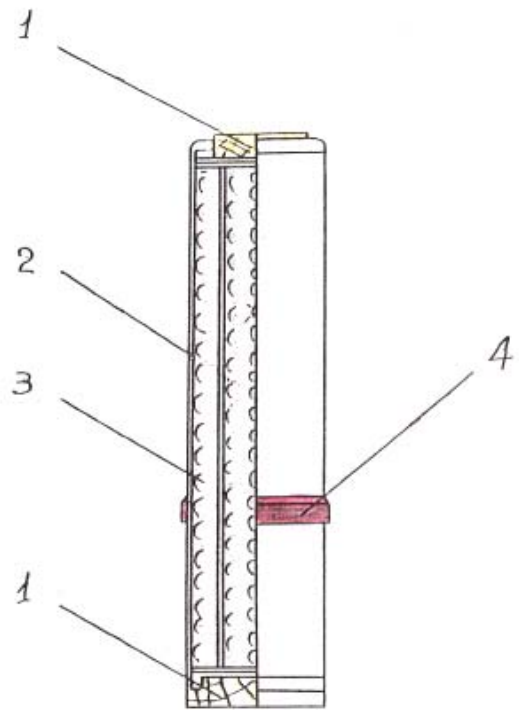

Figure 11. Canister shot shell

- 1. Packing.
- 2. Cylinder
- 3. Canister shot.
- 4. Centring band

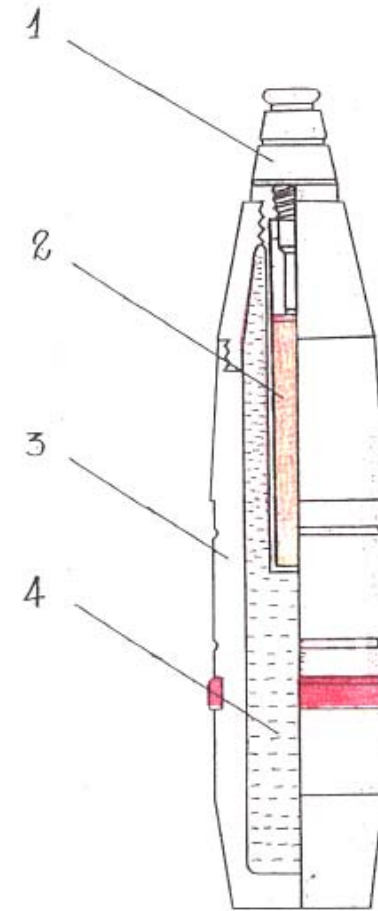

Figure 12. Smoke shell

- 1. Fuze.
- 2. Explosive charge
- 3. Body
- 4. Smoke charge.

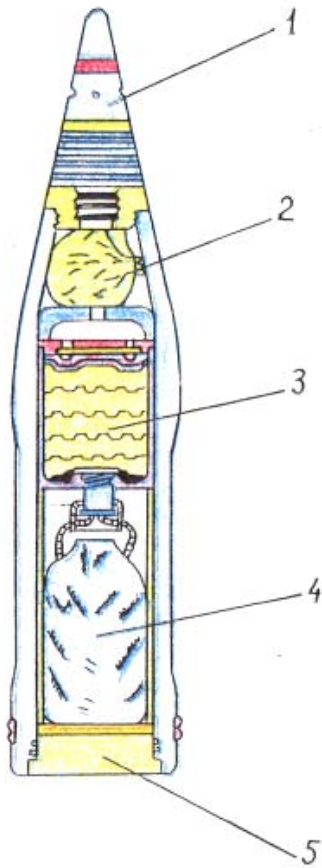

Figure 13. Illuminating shell.

1. Fuze.
2. Gunpowder and smoke.
3. Illumination charge.
4. Parachute
5. Base of shell body.

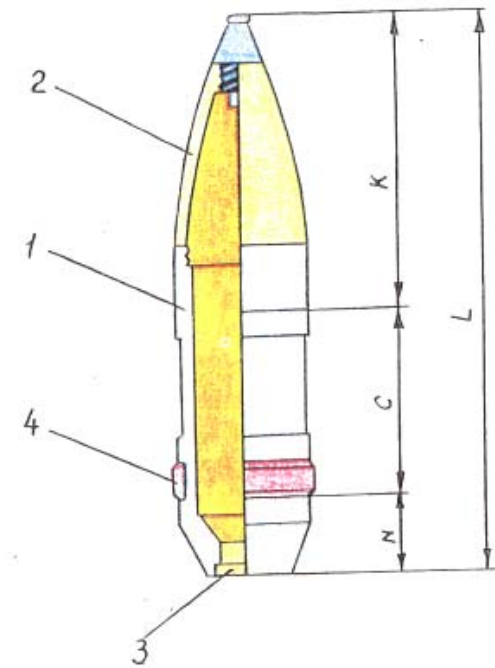

Figure 14. External view of shell.

1. Body.
2. Threaded head.
3. Threaded base.
4. Driving band.
- k. Nose section.
- c. Cylinder section.
- N. Section below band.

In the external view of the shell (Figure 14) the various sections are shown, namely nose section, cylinder section and below-band section.

In the cylinder section are the driving and centring bands. The centring bands are parts which have been machined flush and with a precision fit to the body of the shell. The diameter of these bands is 0.1-0.25 mm. smaller than the calibre of the weapon in which it is used. The driving bands are usually made of copper and are pressed into the annular channels of the body of the shell. The diameter of these bands is some tenths of a millimetre greater than the gun-barrel in accordance with the rifling.

The fuze is a special mechanism which serves to cause the detonation of the shell at the required point in its trajectory; in the air, on impact with an object, or a certain time after impact.

Accordingly, and depending on the target, fuzes can have mechanisms which are capable of causing detonation during the trajectory, or on impact, either immediate or delayed. Fuzes designed to cause detonation in flight are called airburst fuzes, while those which cause detonation on impact are called impact fuzes.

There are fuzes which can perform these two functions. These are called double-action fuzes or distance/impact fuzes. According to their functioning speed impact fuzes may be immediate acting (the interval between impact and detonation is very small), inertial (detonation occurs after the shell penetrates the target by a small amount), or delayed (when the shell detonates at a specified time after impact.)

In fuzes, usually, the initial explosive impulse is received from the ignition of the igniter capsule, from which the detonator capsule detonates, then the fuze detonator, and then the explosive charge of the shell. In connection with this, various mechanisms are used in the fuzes to isolate the igniter capsule from the detonator capsule, or to isolate the latter from the detonator. When the igniter capsule is isolated from the detonator capsule, the fuze is known as "semi-secured", thus even if the igniter capsule detonates prematurely because of some defect, the detonation of the detonator capsule and consequently that of the shell does not take place. Fuzes in which the detonator capsule is isolated from the detonator are known as "secured". In these fuzes premature detonation of the capsules cannot cause premature detonation of the shells.

The classification of fuzes on the basis of the degree of isolation of the capsules in the secured fuze, the semi-secured fuze and the unsecured fuze (where nothing is isolated from the capsules) should not be taken to mean that there is no guarantee of their reliable functioning. For each type of fuze the factories guarantee reliable functioning on the basis of the design calculations, inspections and rigorous testing.

This guarantee of reliable functioning is also made on the basis of the choice of the fuze having the correct type of security, in conformity with the conditions under which and the targets against which it is to be used, the level of guarantee of the capsules etc. Fuzes can be screwed into the nose or the base of the shell. In AP and concrete-piercing shells the fuzes are screwed into the base of the shell (while they are still in the factory) whereas in other shells the fuze is screwed into the nose of the shell. For these shells the fitting of the fuze by the producing factory is usually carried out only for small-calibre munitions (up to 25 mm. and up to 37 mm. in the case of aviation weapons.) On occasion fuzes can be fitted in the factory to certain other types of shells, as for example 60 mm. and 82 mm. mortars, etc. There are many varieties of design in fuzes, and each fuze has its own distinguishing mark and can be used only in one or more varieties of shell..

The propellant charge is a specific quantity of gunpowder placed in the shell-case or sac with the function of propelling the shell towards its target. According to its construction the propellant charge can be variable or non-variable. With variable charges the weight of gunpowder can be altered by removing chargebags containing a specific quantity of gunpowder. Propellant charges, whether variable or not, can be full or reduced.

The shell case contains the gunpowder fumes produced, and forms a base for the assembly of the components of the round and the protection of the propellant charge from physical damage and damp. In some weapons, instead of a shell case, a special sac is used which has the sole tasks of retaining the gunpowder in a specific shape and of preserving it from physical damage to some extent. For protection against damp, bagged charges of this sort are placed in hermetically sealed tubular canisters.

Primers for the propellant can be of percussion or electrical types. Percussion primers are more widely used; they are activated by the striking of the firing pin of the weapon's firing mechanism.

According to the method of loading, rounds can be divided into:

1. **Fixed rounds** (Figure 15) in which all components are fitted into a single case, when loading of the weapon is carried out in one operation.
2. **Semi-fixed rounds (with a shell case)** (Figure 16) in which the shell is separate from the shell case.

In the latter the propellant charge and the igniter capsule are placed in the shell case. The loading of the weapon with these rounds is done in two operations. The propellant charges of semi-fixed rounds are usually variable and consist of a quantity of textile charge bags filled with a specific quantity of gunpowder. Such a method of loading makes it possible to alter the charge during firing by removing the necessary quantity of chargebags.

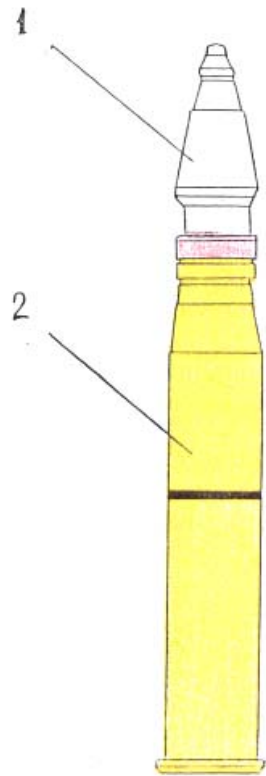

Figure 15. Fixed round
 1. Shell.
 2. Case with propellant charge.

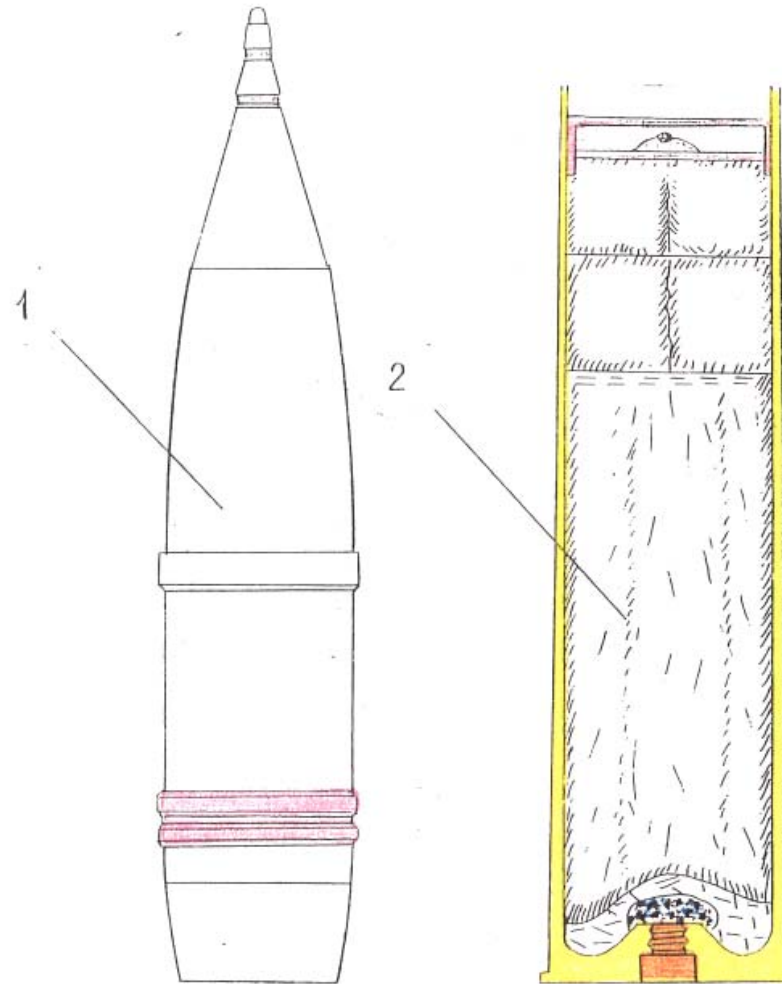

Figure 16. Semi-fixed round (with case)
 1. Shell.
 2. Propellant charge in case.

3. **Separate-loading rounds (with chargebags)** (Figure 17) which can be identified by the lack of case. In these rounds the primer is of a special type. Loading of weapons with this type of ammunition takes place in three phases. Initially the shell is placed in the breech, and then the propellant charge; then the bolt is closed, and finally the primer is inserted.

Blank rounds do not have shells. They consist of a case into which gunpowder of the rapid igniting variety is placed together with a closing cap. (Figure 18.)

Practice rounds (Figure 19) are used for gunnery instruction. They are different from combat rounds because they have simpler shells which during firing simply provide the necessary effect to enable hits to be observed. Practice rounds are filled with inert material.

Training rounds (Figure 20) consist of components which in shape resemble those of combat rounds and do not contain any explosive material.

Mortar rounds (Figure 21) consist of the body of the shell, the stabiliser, the fuze, the base cartridge, and supplementary charges.

The stabiliser serves to stabilise the shell in flight, given that mortar shells do not rotate in flight. The stabiliser consists of a tail unit and two fins. In the tail unit is a specific number of holes which conduct the gases from the gunpowder from the base cartridge to the muzzle and ignite the supplementary charges.

Mortars can fire the following types of shell: fragmentation, HE-fragmentation, HE, incendiary and illuminating (see Illustrations, Figures 5-1 to 5-14).

The base cartridge (figure 22) is placed in the shaft of the tail unit. The supplementary charges are usually in the form of charge bags or in annular strips, which are placed in the frame above the fins of the stabiliser. But occasionally the supplementary charges may be boat-shaped (see Figure 5-4) or in the form of small chargebags which are placed in the slots of the stabiliser fins (see Figure 5-1.)

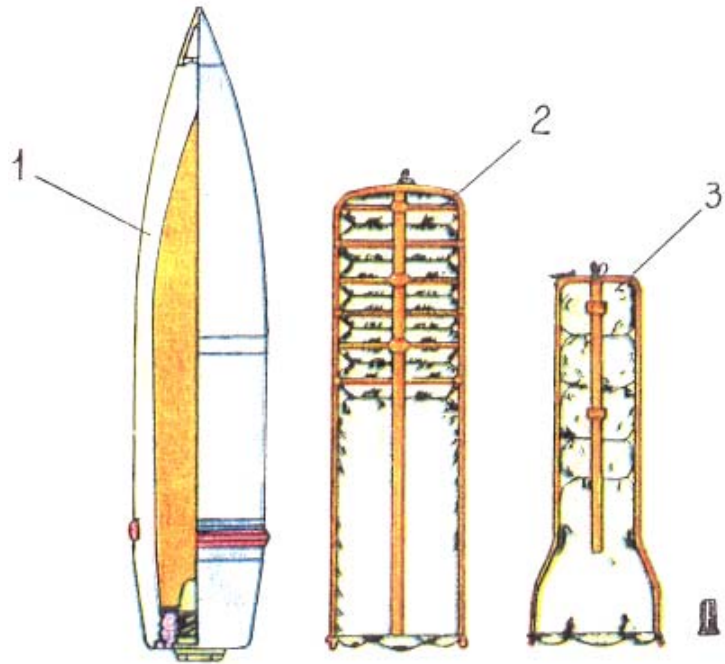

Figure 17. *Separate-loading round with chargebag*

1. Shell.
2. Full propellant charge.
3. Reduced propellant charge.

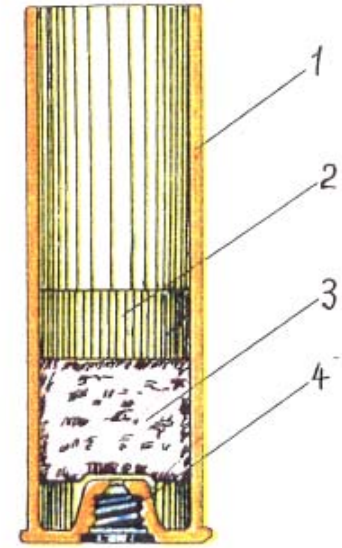

Figure 18. *Blank round*

1. Case.
2. Packing.
3. Gunpowder.
4. Primer.

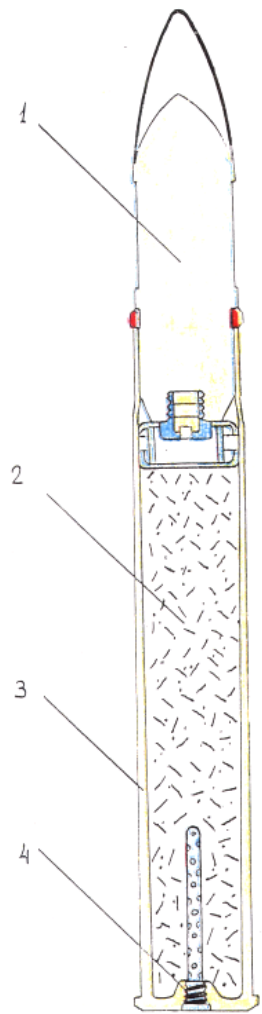

Figure 19. Practice round.

- 1. Shell.
- 2. Propellant charge.
- 3. Case.
- 4. Primer.

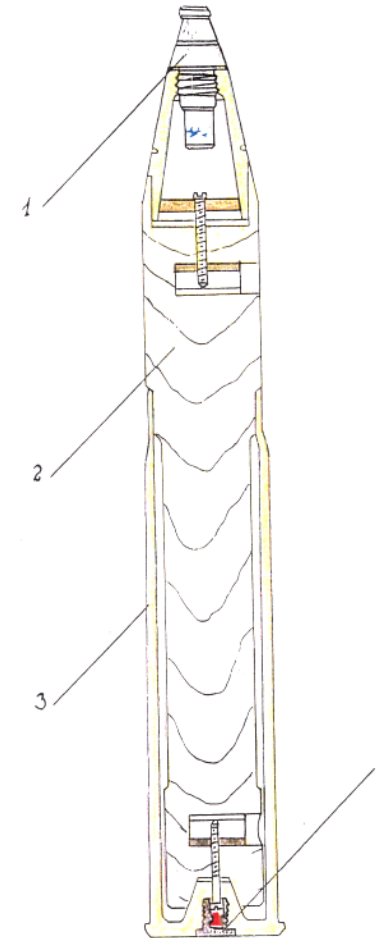

Figure 20. Training round.

- 1. Dummy fuze.
- 2. Wooden or metal shell.
- 3. Case.
- 4. Dummy primer.

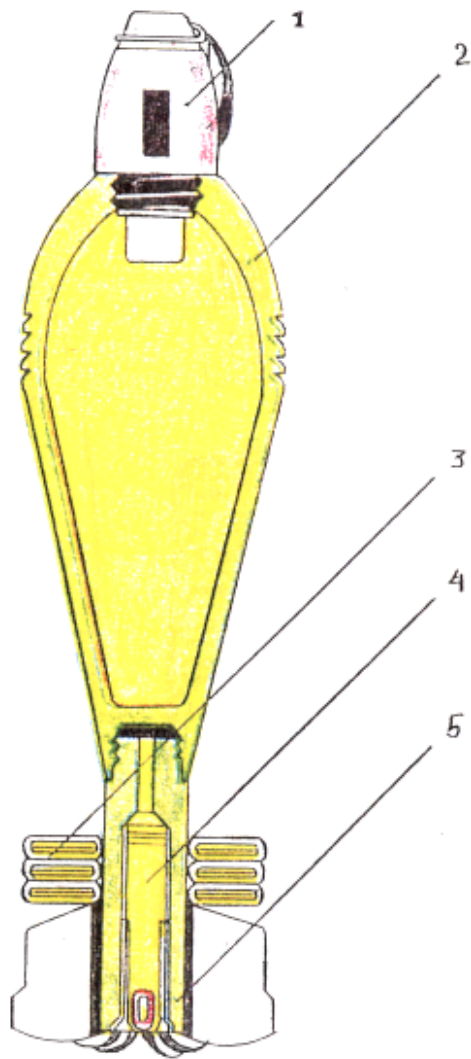

Figure 21. Mortar Round.

1. Fuze.
2. Shell.
3. Propellant charge.
4. Base cartridge.
5. Stabiliser.

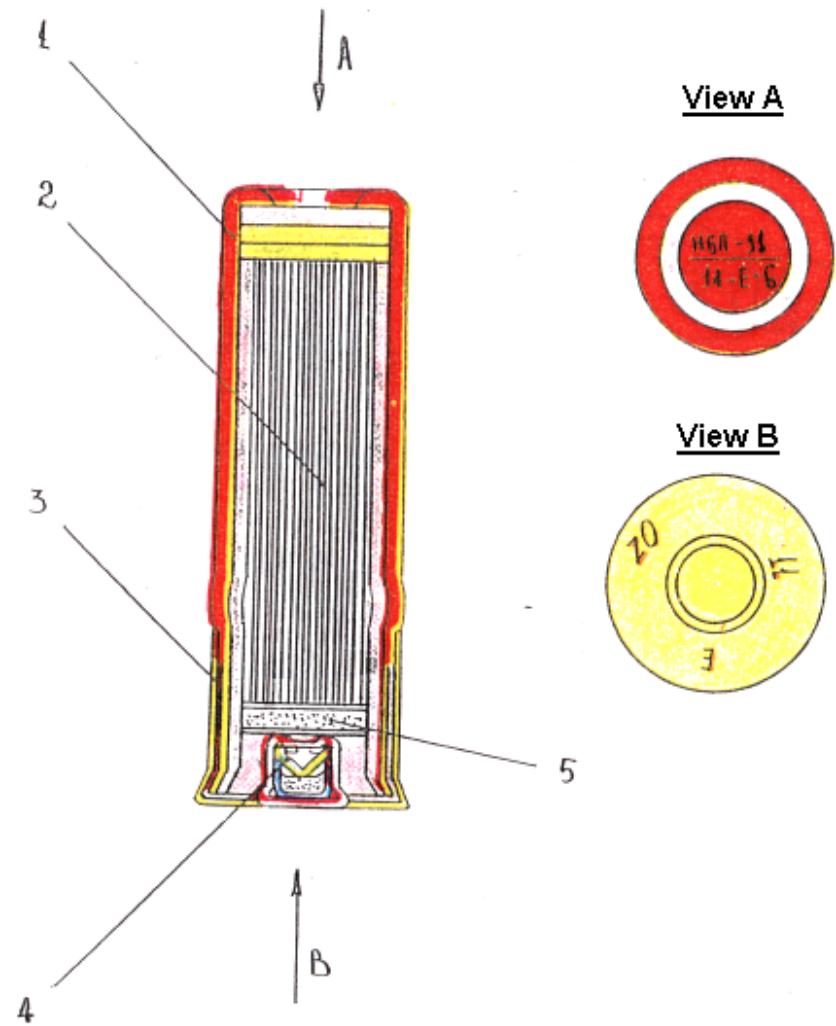

Figure 22. Base cartridge of mortar rounds.

1. Cardboard cylinder.
2. Smokeless gunpowder.
3. Metal base.
4. Primer for gunpowder.
5. Gunpowder (smoke-producing.)

2. The principles of location of indicators on munitions and key to these.

The multiplicity of models dictates the need for the existence of a clear system of designations and distinguishing marks for munitions and their components to avoid confusion in supply and in combat use. Given that it is impossible to write the full designation, normally only conventional signs are shown on weapons and their containers. These show the type, characteristics and use of the munitions. These distinguishing marks consist of indicators and colourings.

The indicators are letters, numbers and other special signs, which are stencilled on to or stamped into the shells (bullets) cases and other munitions components, as well as their containers. Distinguishing colours consist of bands of various colours applied to the shells (bullets), cases and containers, showing the type or special design characteristics of the munitions.

The principles of allocation and the interpretation of the indicators are explained below.

The indicator stencilled on to artillery shells normally contains the information shown in Figure 23. On shells with a base-mounted fuze the type of the fuze is also shown.

The index on the shell consists of a number of letters and three numbers, and there may be one or two letters after the numbers. The letters before the figures show the type of shell, whereas the three numbers show the number and model of the weapon. The letters after the weapon model number show the particular composition of the shell. Thus the index Th – 462 g can be interpreted as follows:

Th	Fragmentation shell.
462	Weapon model number – in this case the 122 mm. howitzer, 1954 model.
g	The body of the shell is cast iron.

Tables 1, 2 and 3 show the meaning of the letters indicating the type of shell, the particular composition of the shell, and the type of explosive for weapons of Albanian, Chinese and Soviet manufacture.

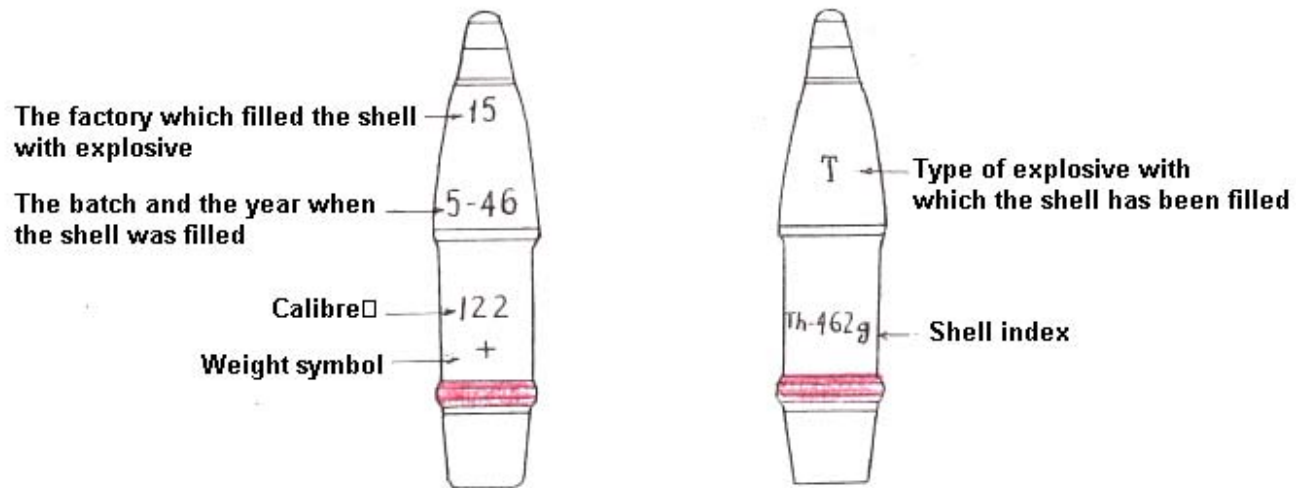

Figure 23. The allocation and interpretation of indicators stencilled on to artillery shells.

Table No. 1

Key to letters indicating type of shell
(these letters are found at the start of the index number)

Serial/ column no.	Type of letter			Designation of shell	Remarks
	Albanian	Chinese	Soviet		
	2	3	4	5	6
1	T _h	杀	o	Fragmentation	
2	E	炸	φ	HE	
3	E TH	杀 炸	o φ	HE/Fragmentation	
4	B	甲	Б	AP	
5	B GJ	电 甲	БP	AP – tracer	
6	D	燃	з	Incendiary	
7	B D GJ	电 甲 燃	зP	AP/Incendiary/tracer	
8	A	石皮	БП осе Бк	HEAT	
9	Bc	-	Г	Concrete-piercing	
10	T	烟	Д	Smoke	
11	N	明	С	Illuminating	
12	TH GJ	电 炸	OP	Fragmentation-tracer	
13	K	-	-	Canister shot	

Table No. 2

**Key to letters showing particular features in the configuration of shells
(These letters are found in the index number after the weapon model number)**

Serial/ Column. no.	Type of letter			Remarks	
	Albanian manufacture	Chinese manufacture	Soviet manufacture		
1	2	3	4	5	6
1	g	—	Λ	1. Fragmentation shells: cast iron body 2. AP shells: the nose of the shell is shaped as illustrated	<i>See Figure 2-27 on page 187</i>
2	—	—	Λ		
2	sh	—	Б	The body of the shell has a flat nose	
3	pl	—	сп	Solid shell	
4	Nen	—	п	Sub-calibre shell	
5	t	—	к	Shell for ground attack	
6	p	—	γ	Shell with improved design	
7	—	—	Д	Mortar bomb with 10 stabilising fins	
8	ç	—	с	Steel-bodied mortar bomb	

Table No. 3

Key to letters indicating the type of explosive with which the shell has been filled.

Serial	Type of letter			Remarks	
	Albanian	Chinese	Soviet		
1	2	3	4	5	6
1	T	梯	T osc TNT	Tritol	
2	Tit	梯 铝	T A Y	Tritol with a quantity of smoke-generator	
3	TD-42	梯 壳 -42	T A -42	Mixture of Tritol (58%) with dinitronaftalin (42%)	
4	H	黑	Г	Hexogen	
5	TH-50	黑 梯 -50	ГГ - 50	Mixture of Tritol (50%) and hexogen (50%)	
6	Hf1-1	黑 铝	A-IX-1	Phlegmatised hexogen	
7	Hf1-2	黑 铝	A-IX-2	Mixture of phlegmatised hexogen (80%) with powdered aluminium (20%)	
8	Sh	毒	Ш	Schneiderite (surrogate explosive)	
9	ShT	梯 毒	ШТ	Schneiderite with a quantity of tritol, which is placed in the upper part of the shell as damp-protection.	
10	A-40 dhe A-90	-	A-40 dhe A-90	Amatol (mixture of tritol and ammonium nitrate); the numbers 40 and 90 indicate the percentage of ammonium nitrate in the amatol.	
11	AT-90	-	AT-90	Amatol with 10% tritol and 90% ammonium nitrate and with a tritol capping for damp protection.	
12	F	-	F-4	Smoke generator (phosphor)	
13	HTT1	-	ГТТ	Mixture of Hexogen with tritol and tetryl.	

Weight designators – indicate the underweight/overweight of the shell as against the nominal weight (as per drawing). The meaning of these is given in Table 4.

Table 4

	Weight designators	Underweight/overweight in %
Underweight	L	More than 3%
	----	From 2 1/3 to 3%
	---	From 1 2/3 to 2 1/3%
	--	From 1 to 1 2/3%
	-	From 1/3 to 1%
Overweight	N or ±	Between □% underweight and 1/3% overweight
	+	From 1/3 to 1%
	++	From 1 to 1 2/3%
	+++	From 1 2/3 to 2 1/3%
	+++	From 2 1/3 to 3%
	R	More than 3%

Instead of the letter L, Soviet munitions display the letters ЛЛ.

Instead of the letter N, Chinese munitions display the marking ±, and Soviet munitions the letter H.

Instead of the letter R, Soviet munitions display the letters ТЖ.

On artillery shells the information depicted in Figure 24 is shown both stencilled on the exterior and stamped into the metal.

The information stamped into the metal of the shell can be clearly seen if the layer of paint is removed. This will only be done when some defect has occurred, in order to obtain the data from the metal body of the shell.

On the cases of artillery rounds the coloured indicators appear on the cylindrical section, whereas on the base section the indicators are stamped. In figures 25 and 26 the information normally contained in these indicators is shown.

The index number on the rounds is almost identical to that on the shell, with one alteration, namely that in front of the letters indicating the type of shell there is a letter which indicates the type of round. These letters can be one of two:

U designates a fixed round (where the shell is in one piece with the case and the charge).

V designates a semi-fixed round (where the shell is separate from the propellant charge placed in the case).

With munitions of Chinese and Soviet manufacture the letter Y replaces the letter U and the letter B replaces the letter V.

In some cases the letters ZV (Russian equivalent Y) will appear after the weapon model number, indicating that the round has a reduced quantity of propellant.

The words "Type of gunpowder" mean the letters and numbers which indicate the composition, form and dimensions of the gunpowder. Often in this designation there appear letters which indicate the distinctive characteristics of the composition or manner of production of the gunpowder.

Gunpowders made from nitro-cellulose (Pyroxiline) do not have any type indicator letter, but the specific absence of such letter indicates that the powder is made from nitro-cellulose, such as for example powder of types 9/7; 12/7 etc.

Nitro-glycerine-based gunpowders have at the beginning of the type designator the letter N (** for Chinese-made munitions, and H for those of Soviet manufacture), while those made from dinitroglycol have the letters Dg (** for Chinese munitions, and ДГ for those of Soviet manufacture.)

Gunpowders made from nitro-cellulose are usually produced in the form of granules and only rarely in tubular form. In the latter case after the make numbers the letter g appears (** on Chinese munitions and Tp on those of Soviet origin.)

Gunpowders made from nitro-glycerine and dinitroglycol are not produced in granular form, therefore in all cases when the make designator of these has a divided number e.g. NDT 18/1 etc., this means that the gunpowder is in tubular form.

The key to type designators and to the letters which indicate special characteristics in the composition and production of the gunpowder are shown in Tables 5, 6 and 7.

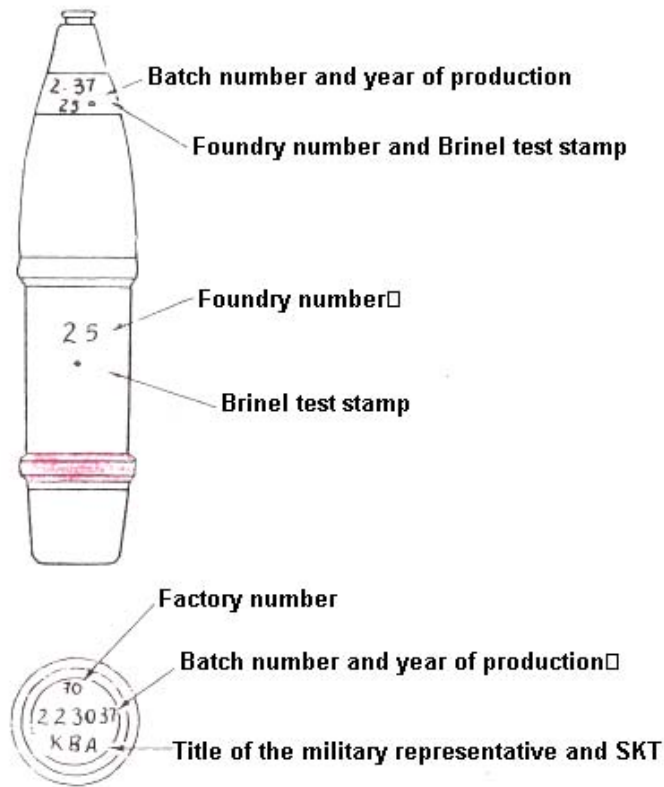

Figure 24. Allocation of and key to indicators stamped into artillery shells

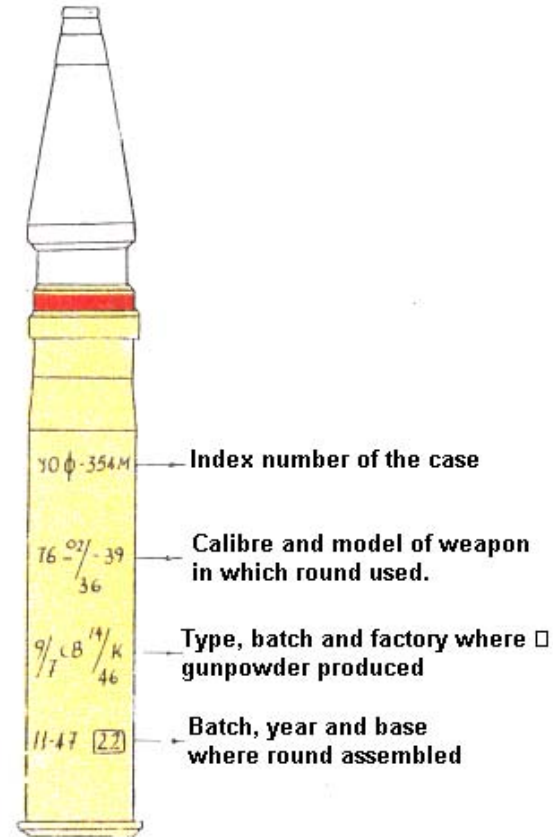

Figure 25. Allocation of and key to coloured markers stencilled on the cylinder section of fixed round cases.

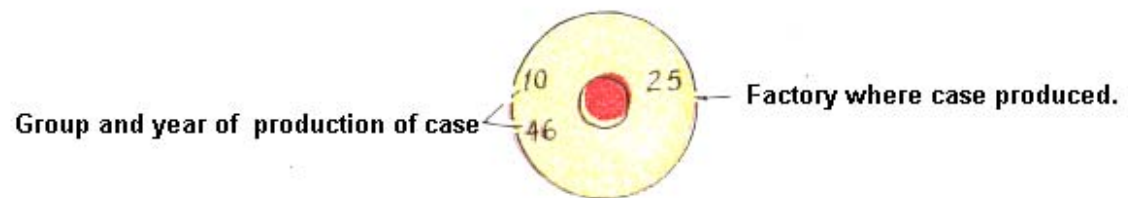

Figure 26. Allocation of and key to indicators stamped on base of case.

Table No. 5

Key to types of gunpowder

TN; The Chinese characters have been omitted, only numbers and blanks being shown. Where numbers accompany characters, the accompanying characters are shown by asterisks

Serial	Albanian production	Chinese production	Soviet production	Key to letters
1	2	3	4	5
1	2/1 4/1 12/1, 18/1 etj.	4/1 12/1, 18/1 etj.	4/1 12/1, 18/1 etj.	Nitro-cellulose gunpowder in granular form with one channel and with respective thickness of 0.2, 0.4, 1.2, 1.8 mm. etc.
2	4/7, 5/7 6/7, 7/7 9/7, 11/7 12/7, 14/7 etj.	4/7, 5/7 6/7, 7/7 9/7, 11/7 12/7, 14/7 etj.	4/7, 5/7 6/7, 7/7 9/7, 11/7 12/7, 14,7 etj.	Nitro-cellulose gunpowder in granular form with seven channels and with respective thickness of 0.4, 0.5, 0.6, 0.7, 0.9, 1.1, 1.2, 1.4 mm. etc.
3	7/14 9/14 etj.	7/14 9/14 etj.	7/14 9/14 etj.	Nitro-cellulose gunpowder in granular form with fourteen channels and with thickness of 0.7, 0.9 mm. etc.
4	P	—	β _{II}	Porous nitro-cellulose gunpowder for pistol rounds
5	3/1	—	BT o _{sc} β.Λ	Nitro-cellulose gunpowder for model 53 (small arms) rounds
6	2/1	结单	BY	Nitro-cellulose gunpowder for model 56 (small arms) rounds

Serial	Albanian manufacture	Chinese manufacture	Soviet manufacture	Key to letters
Column no.	2	3	4	5
7	P-45 P-220 etj.	—	П-45 П-220 etj.	Porous nitro-cellulose (with many pores) with 45%/220% potassium nitrate inserted during production for the formation of pores.
8	PI-10-10	双片 -10-10	ПЛ-10-10 etj.	Nitro-cellulose gunpowder in square slab form with sides of 1 mm. length and with 0.1 mm. thickness.
9	NBSH-11 NGB-35 NBSH-50 NBSH-80 etj.	双片 -11 双片 -35 双片 -50 双片 -80 etj.	НБЛ -11, НБЛ -35 НБЛ -50 НБЛ -80 etj.	Nitro-glycerine gunpowder (ballistite variety) in strip form with respective thicknesses of 0.11, 0.35, 0.5 and 0.8 mm.
10	NBPI-42-20	双片 -42-20	НБПЛ-42-20	Nitro-glycerine gunpowder (ballistite variety) in square slab form with sides of 2 mm. length and with 0.42 mm. thickness.
11	NBU-32/65-14 osc NGB-14-32x65	双片 32/65-14	НБК 32/65-14	Nitro-glycerine gunpowder (ballistite variety) in annular form with internal diameter of 32 mm. and external diameter of 65 mm., and thickness of 0.14 mm.
12	NBTH-13-47	双片 中甲 13-47	НБТН-13-47	Nitro-glycerine gunpowder (ballistite variety) in rod form with length of 47 mm. and thickness of 0.13 mm.

Serial	Albanian manufacture	Chinese manufacture	Soviet manufacture	Key to letters
Column no.	2	3	4	5
13	—	—	WMD 17/32	Nitro-glycerine gunpowder (cordite) in rod form with length of 32 mm. and thickness of 0.17 mm.
14	NDT-3 18/1	双赤 - 3-18/1	HAT-3 18/1	Nitro-glycerine gunpowder (ballistite variety) with added dinitrotoluol with flash point 3, in tube form with thickness of 1.8 mm.
15	DG-3 18/1	双赤 - 3 18/1	ДГ -3 18/1	Dinitroglycol gunpowder with combustion level 3, in tube form with thickness of 1.8 mm.
16	—	—	KM	Cordite gunpowder for mortars
17	3/1 M	单红	BTM	Nitro-cellulose gunpowder for mortars
18	—	75/50	75/50	Gunpowder for Reduced Charges for coastal artillery gun
19	—	100/56	100/56	Gunpowder for 100 mm. coastal artillery gun with barrel length of 56 x calibre
20	—	130/50	130/50	Gunpowder for 130 mm. coastal artillery gun with barrel length of 50 x calibre
21	—	130/58	130/58	Gunpowder for 130 mm coastal artillery gun with barrel length of 58 x calibre

Table No. 6

Key to letters indicating special features of composition of gunpowders

Serial	Albanian letters	Chinese characters	Russian letters	Key
1	r	新	CB	Gunpowder produced with new nitro-cellulose
2	rs	—	CT	Gunpowder with other stabilising material added by factory.
3	rp	—	ПЕР	Gunpowder reprocessed in factory
4	fl	—	ФЛ	Phlegmatised gunpowder
5	—	—	ОД	Gunpowder imported by the Soviets during the Second World War
6	px	—	CM	Gunpowder manufactured in the factory from a mixture of various old batches.
7	gt	—	ГР	Graphited gunpowder
8	fsh	松	УГ	Gunpowder containing flash suppressant
9	pf	—	БП	Flashless gunpowder

Table No. 7

Key to letters indicating special features of composition of gunpowder

Serial	Albanian letters	Chinese characters	Russian letters	Key
1	-	-	СФ	Gunpowder produced by incomplete technological process
2	-	-	В/В	Wartime production
3	-	-	УФ	Gunpowder produced by abbreviated technological process

The combustion of gunpowder takes place simultaneously (*on all exposed surfaces*), so that its combustion time is proportional to one half of its thickness.

For this the term "Gunpowder combustion thickness" is often used, which we understand to mean half the thickness of the layer of the granule, tube or slab of gunpowder (see figure 27.)

On the cases of semi-fixed rounds and the chargebags the indicators shown in Figures 28 and 29 are shown.

The letters at the beginning of the index number of the charge can be of three types: a key is given in Table No. 8.

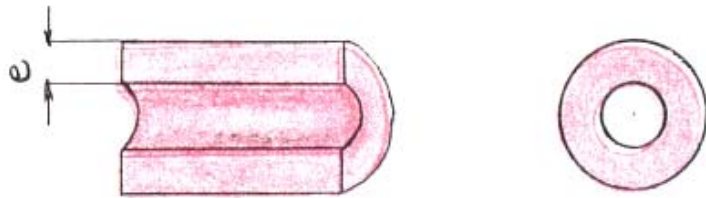

One half of the thickness of the gunpowder layer, i.e. $\frac{e}{2}$ is called "Combustion thickness."

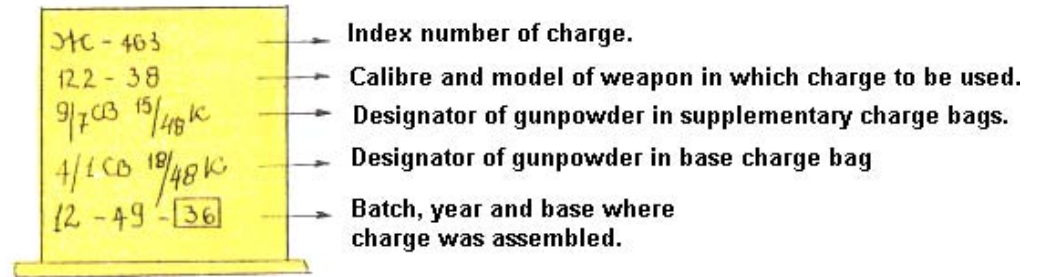

Figure 27. Combustion thickness of gunpowder.

Figure 28. Allocation of and key to coloured indicators on the cylinder section of cases for semi-fixed rounds.

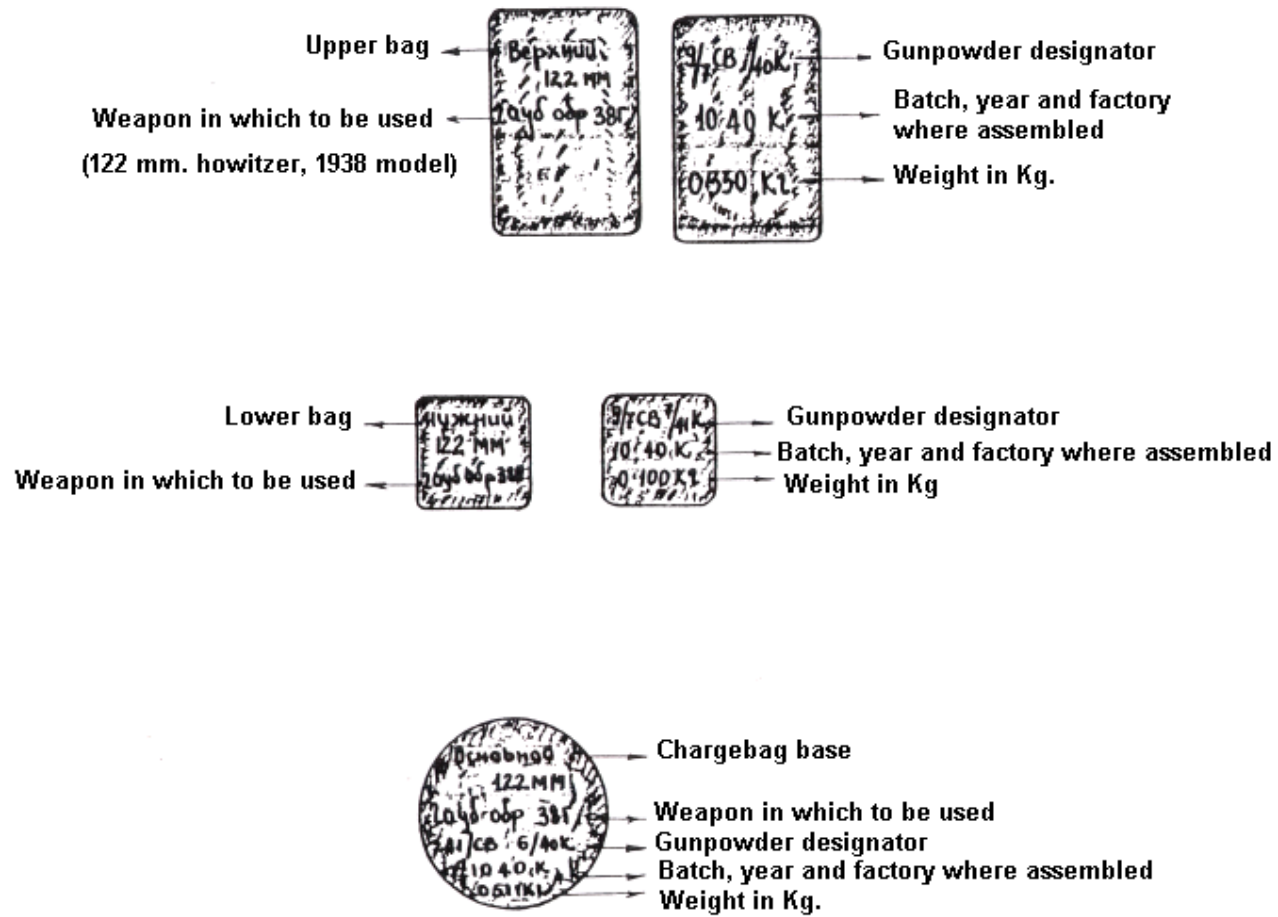

Figure 29. Allocation of and key to Designators on chargebags.

TN; the words upper, lower and base are written in Russian on the respective bags as illustrated above, and are therefore used throughout.

Table No. 8

Serial	Albanian letters	Chinese characters	Russian letters	Key
1	M	-	Ж	Charge placed in case
2	Mq	-	З	Charge placed in chargebag
3		-	Б	Bagged charge for placing in case

Cases and packaging of Soviet and Chinese manufacture often carry other special indicators, the key to which is given in Table No. 9

Table No. 9

The Russian words have not been reproduced, as they correspond to the translation

Serial	Designation or special mark –Chinese production	Designation or special mark – Soviet production	Translation of designation or meaning of blank
1	全	ЗАР. ПОЛНЫЙ	Full Charge
2	—	Полный переменный	Full Variable Charge
3	—	ЗАР. Специальный	Special Charge
4	—	Уменьшенный	Reduced Charge
5	—	Уменьшен. перемен.	Reduced Variable Charge
6	—	дальнобойный	Long range Charge
7	—	Боев. зар.	Combat Charge
8	—	Боев. беспламенный	Flashless Combat Charge
9	—	Зар. №3, №4, etc.	Charge No. 3, No. 4, etc.
10	消	ПГ	Charge includes flash suppressant
11	护	Ф	Charge includes phlegmatiser
12	除銅封	ФР	Charge includes phlegmatiser and decoppering agent

The designators shown in Figure 30 are stamped into the cases of fuzes and primers. The settings of fuzes are shown by letters. Table 10 provides the key.

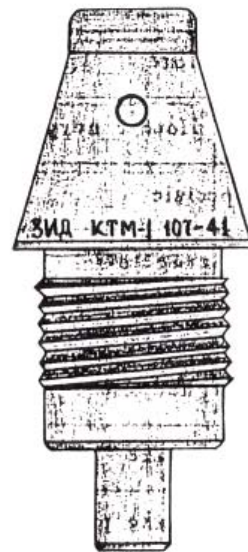

Key

- Producing Factory**
- KTM-1-Type of fuze**
- 107--Production batch**
- 41--Year of production (1948)**

Key

- 42-M--Producing factory**
- 2--Production batch**
- 54--Year of production (1954)**
- KB-4--Primer designator**
- Stamp of military representative**
- Stamp of technical control section**



Figure 30. Allocation of and key to designators stamped into the metal body of fuzes and primers

Table No. 10

Key to letters indicating fuze settings

Serial	Albanian letters	Chinese characters	Russian letters	Fuze setting
1	th	茶	0	Fragmentation
2	v	延	3	Delay
3	pm	—	к	Transport setting
4	g	—	у/д	Impact
5	k	—	к	Canister shot

The coloured indicators on artillery ammunition boxes as shown below(Figures 31,32,33) indicate as follows:

On small arms ammunition the factory number and year of production are stamped on the base of the round.

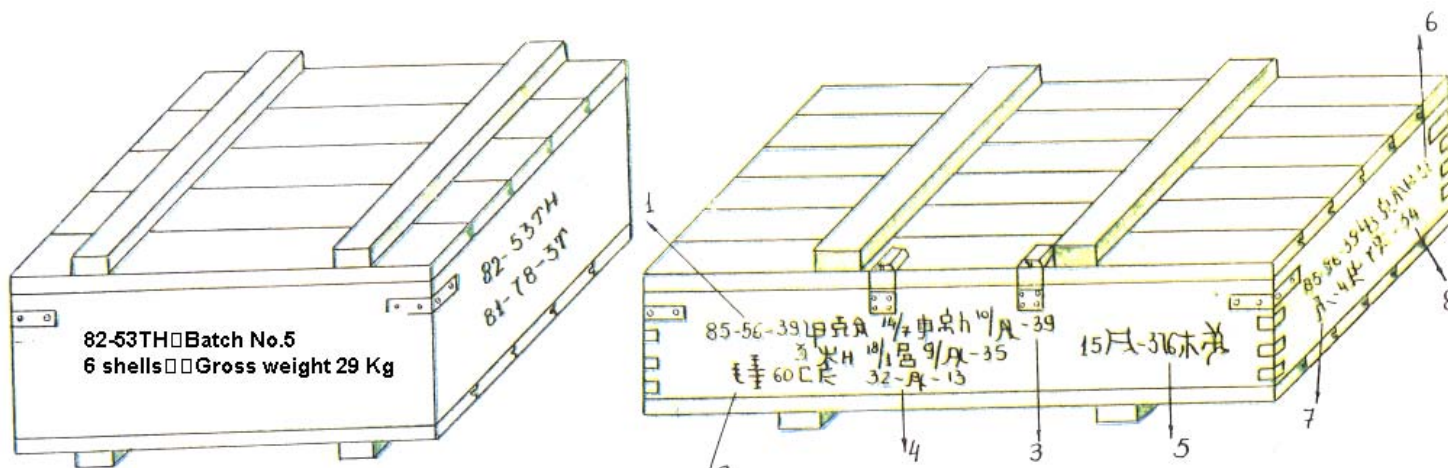

Key:

- 82-53 Th Fragmentation shell for 82 mm. mortar, model 53
- 81-78-3T Batch No.(81), year of production (78), factory No. 3, T is type of charge (tritol.)

Figure 31. Allocation of and key to designators on Albanian-produced artillery ammunition.

Key:

- 1. Calibre and model of weapon in which round is to be used
- 2. Gross weight of box.
- 3. Gunpowder designator.
- 4. Batch (32), year (59) and factory (13) of assembly.
- 5. Batch, year factory where shell filled, indicator showing explosive used in shell (tritol.)
- 6. Calibre and model of weapon.
- 7. Designator of primer. (KV-4)
- 8. Batch, year and factory where primer produced.

The designators used on ammunition boxes containing small-arms ammunition are shown in the examples below. (see figures 35, 36, 37.)

Table 11 gives the key to the letters indicating types of small arms ammunition on boxes.

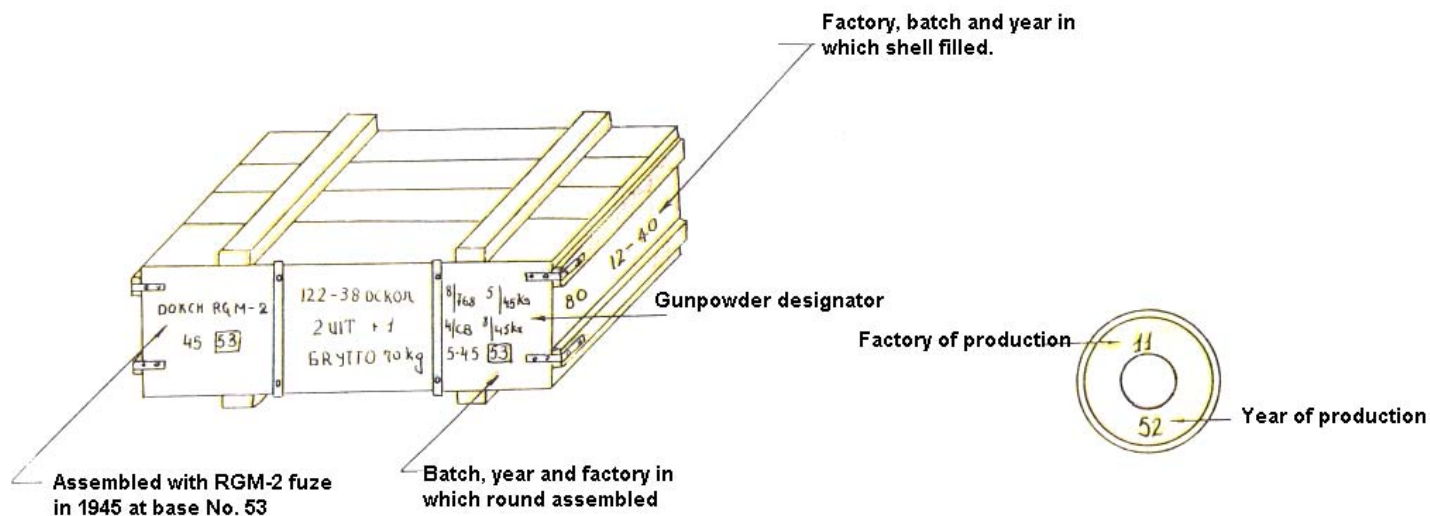
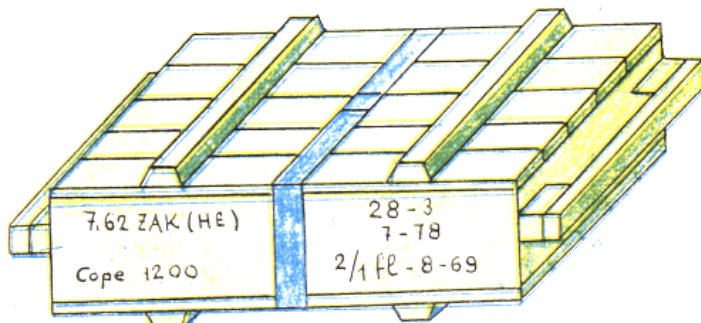

Figure 33.-Allocation of and key to designators on Soviet artillery ammunition boxes

Figure 3-Key to designators stamped on the base of small-arms rounds.



Key:

- 7.62 ZAK (HE): 7.62 mm. rounds , model 56, with bimetallic case.
- 28-3: Number of batch (28) and Factory (3) of production.
- 7-78: Month and year of production of rounds.
- 2/1fl-8-69: Type, batch number (8) and year (1969) of production of gunpowder.

Figure 35. Allocation of and key to designators on boxes containing small arms ammunition of Albanian manufacture.

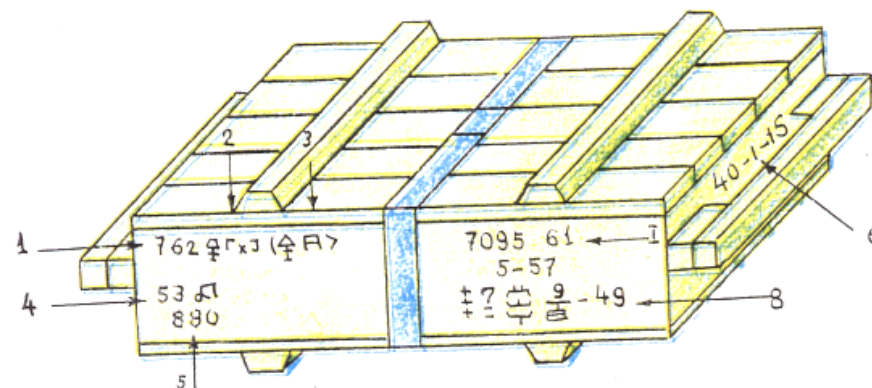

Key:

- 1. Calibre of rounds.
- 2. Type of rounds.
- 3. Type of case.
- 4. Model type (1953 model.)

Note:

- 1. 1953 model rounds are identical to old-model Soviet rounds.
- 2. 1956 model rounds are identical to new-model Soviet rounds.
- 5. Quantity contained in box.
- 6. Designator for small arms ammunition.
- 7. Batch (7095), factory (61) month (5) and year of manufacture (1957) of the rounds.
- 8. Type, batch, year and factory of production of gunpowder.

Figure 36. Allocation of and key to indicators on small arms ammunition boxes of Chinese manufacture

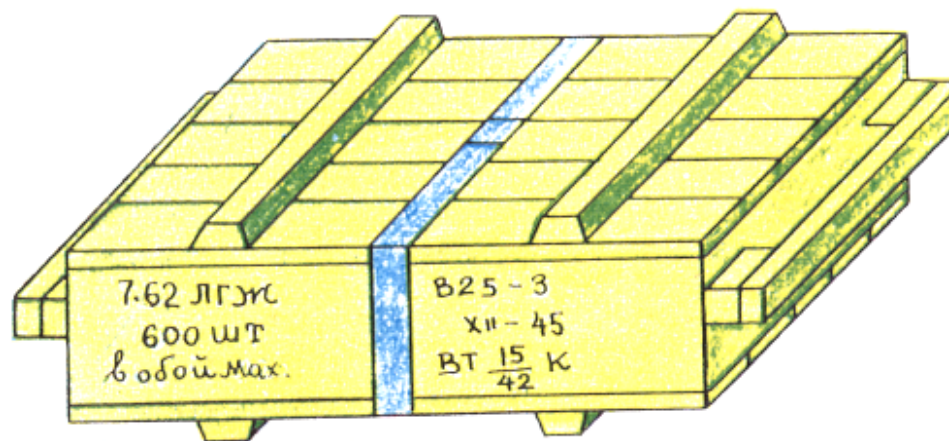

KEY

7.62	Calibre of rounds.
ЛГЖ	Type of rounds and of type of metal used for case .
600 ШТ	Number of rounds.
В 25-3	Batch and factory of production.
XII-45	Month and year of production.
ВТ $\frac{15}{42}$ -К	Type, batch, year and factory in which gunpowder produced.

Figure 37. Allocation of and key to indicators on small arms ammunition boxes of Soviet manufacture.

Table No. 11

Key to letters which indicate types of small arms ammunition.

Serial	Albanian letters	Chinese characters	Russian letters	Key to letters
1	p	手 普	п*	Pistol round
2	pl	普	л	Lightweight round
3	pc	—	д	Heavy round
4	bd	穿 火 燃	БЗ осе Б-32	AP incendiary round
5	kd	識 火 燃	пЗ	Incendiary tracer round
6	d	燃	з	Incendiary round
7	gj	电	Т-46	Tracer round
8	bdgj	穿 火 燃 电	БЗТ	AP incendiary tracer round
9	—	—	БС-41	AP incendiary round with special core
10	—	钢	пс	Conventional round with steel core

The type of metal of the round is indicated by letters: the key is in Table 12.

Table No. 12

Key to letters which indicate the type of metal used for small arms rounds.

Serial	Albanian letters	Chinese characters	Russian letters	Key to letters
1	GHE	鐵	ГЖ	Iron case
2	GÇ	鋼	ГС	Steel case
3	GT	銅	ГЛ	Brass case

The year of production or assembly of the munitions is usually indicated by the last two numbers, but on Soviet munitions produced in the period 1949-1956 the year of production (assembly) is indicated by letters: the key to these is in Table No.13. Likewise with some Chinese-produced munitions the year of production (assembly) is indicated by letters, signs, or a number: the key to these is in Table 14.

Table No.13

Key to letters indicating year of production (assembly) of Soviet-manufactured munitions

Serial	Letter	Year	Serial	Letter	Year
1	A	1949	5	Д	1953
2	Б	1950	6	Е	1954
3	В	1951	7	И	1955
4	Г	1952	8	К	1956

Table No.14

Key to letters (symbols) and numbers indicating year of production (assembly) of Chinese-manufactured munitions

Serial	Letter (symbol)	Number	Year indicated	Remarks
1	—	1	1951	
2	—	2	1952	
3	—	3	1953	
4	54 052 2	4	1954	
5	牛	5	1955	
6	未	6	1956	
7	申	7	1957	
8	由	8	1958	
9	戊	9	1959	
10	子	10	1960	
11	61	11	1961	

Boxes of hand grenades have indicators as shown in Figures 38,39 and 40.

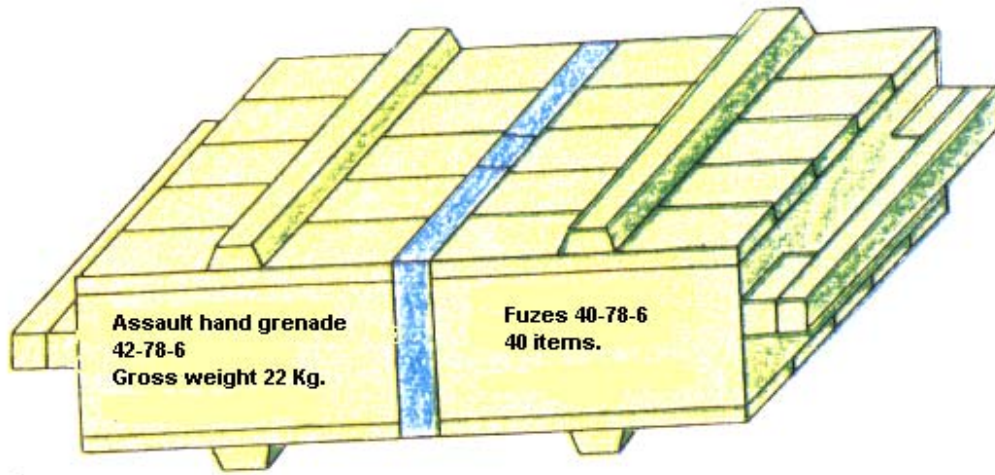

KEY

42-78-6: Batch number (42), year (78) and factory in which grenades produced.

40-7B-6: Batch number (40), year (7B) and factory in which igniters produced.

Figure 38. Allocation of and key to designators on Albanian-manufactured grenades.

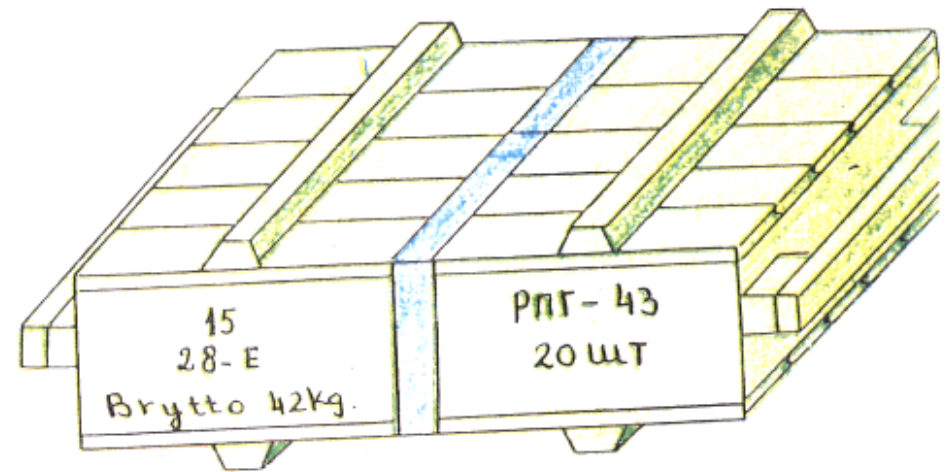

Key

15

28-E: Factory (15), batch number (28) and year (1954) of production of grenades.

PHГ-43 (RPG-43): Grenade model (handheld anti-tank grenade, model 43.)

Brytto 42 KГ: Gross weight 42 Kg.

20 шт: Quantity in box – 20.

Figure 39. Allocation of and key to designators on Soviet-produced grenades

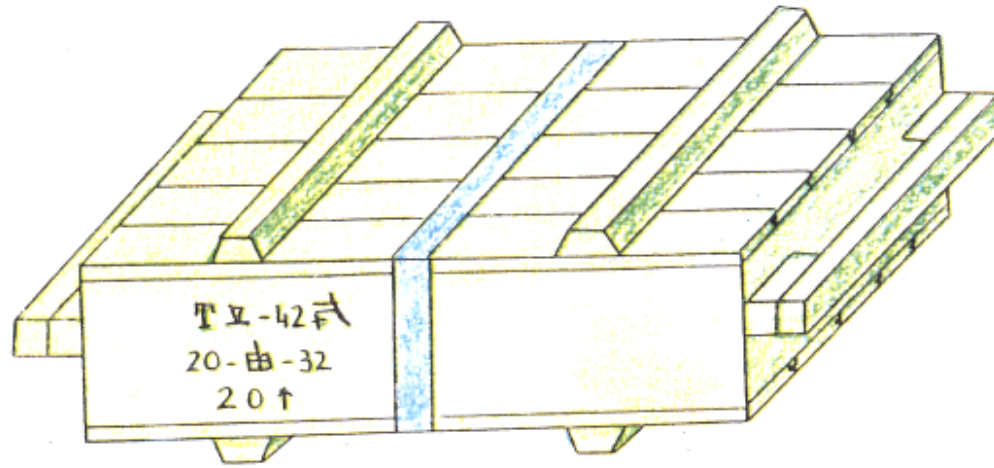

Key

- IX-42 *: Grenade model (Assault hand grenade model 42.)
- 20-*-32: Batch number (20), year (1958) and factory (32) in which grenades produced.
- 20: Quantity of grenades in box. (20).

Figure 40. Allocation of and key to designators on Chinese-manufactured grenades

Table No. 15

Key to grenade designators

Serial	Index on Albanian production	Index on Chinese production	Index on Soviet production	Key to index
1	—	攻 -42 式	РГ - 42	Assault hand grenade model 42
2	541	攻 -59 式	—	Assault hand grenade model 59
3	542	防 -1 式	Ф -1	Defensive hand grenade
4	—	—	РПГ -43	Anti-tank hand grenade model 43
5	—	—	РПГ -6	Anti-tank hand grenade model 6
6	—	РКГ - 3 Т 3 式	РКГ - 3	Anti-tank hand grenade model 3

3. Colour coding of munitions

The colour coding of munitions can be either protective or for distinguishing purposes. Protective colour-coding is usually applied to shells and to metal and wooden ammunition boxes. As a rule shells produced in wartime are not colour-coded, but are simply greased with summer shell grease.

Distinctive colouring is applied to shells, small arms rounds, and their packaging. This colouring is applied both in peacetime and wartime.

Distinctive colouring is applied to artillery shells in the form of coloured bands, which signify as follows:

Blue band – concrete-piercing shell.

White band – illuminating shell.

Red band – incendiary or AP-incendiary – tracer.

A black band, if it is close to the upper centring band, indicates a smoke round, whereas if it is close to the lower centring band, (with mortar rounds under the centring band), it indicates that the body of the shell is made of cast iron.

On the cases of artillery rounds a black band indicates that there is a reduced quantity of propellant.

A white band on the base of the primer or the case indicates that they have been used and refilled.

On small arms rounds distinctive colouring is applied to the nose of the bullet, and to packaging; the meaning of such colouring is given in Table No. 16.

Table No. 16

Serial	Distinctive colouring on small arms rounds	Distinctive colouring on boxes	Meaning
1	Yellow nose	Single yellow band	Round with heavyweight bullet
2	Red nose	Single red band	Round with incendiary or incendiary tracer bullet
3	Green nose	Single green band	Round with tracer bullet
4	White nose	Single white band	Round with lightweight (conventional) bullet with steel core
5	Black nose	Single black band	AP round
6	Black nose with red ring below	Two bands – black and red	Round with AP-incendiary bullet
7	Violet nose with red ring below	Two bands – violet and red	Round with AP-incendiary-tracer bullet
8	Black nose – remainder red	Two black rings and black sides to box	Round with AP-incendiary bullet with special core

TN; Different words are used for "band" and "ring."

CHAPTER II

MUNITIONS FOR ARTILLERY WEAPONS

I. MUNITIONS FOR 23 mm. AIRCRAFT CANNON (FIGURES 2-1 AND 2-2)

Rounds for all calibres of Aircraft cannon are fixed-type with fuzes fitted to the shells at the factory.

1. Shells for 23mm. Aircraft cannon

Serial	Designation of shell	Index	Weight (Kg).	Length including fuze (mm.)	Charge		Fuze fitted	Colour code
					Type	Weight		
1	Fragmentation incendiary tracer	-	0.196	109.35	Mixture of phlegmatised hexogen with powdered aluminium	0.011	A-23 K-20M	None
2	AP incendiary with shaped charge	-	0.199	102	None	-	None	None

Note: Self-destruction of the fragmentation incendiary tracer round in the air is effected by means of the tracer.

2. Rounds for 23mm. Aircraft cannon

Serial	Designation of round	Index	Weight (Kg.)	Length (mm).	Propellant Charge		Case			Colour coding
					Type of powder	Weight (Kg.)	Weight (Kg.)	Length (mm.)	Primer type	
1	Fixed round with fragmentation incendiary tracer shell	NS -23 OZT	0.340	200	4/7 GR	0.033	0.111	115	ZTN	Green band above driving band; <i>see note below</i>
2	Fixed round with AP incendiary shell	NS -23 BZ	0.340	200	4/7 GR	0.033	0.111	115	ZTN	None

TN: The word used for green is jeshil, as opposed to the normal word i/e gjelbër. No difference in meaning can be established from the dictionaries consulted.

3. Packaging for munitions for 23mm. Aircraft cannon

Serial	Type of munition	Quantity in box	Dimensions of box (cm.)	Weight of box (Kg.)	Remarks
1	Rounds	132	75 x 36 x 16	58	

II. MUNITIONS FOR 25 mm. AA GUN MODEL 1940 (SEE FIGURES No. 2-3 and 2-4)

Rounds for the 25 mm. AA gun are fixed. The cases of these rounds differ from those of naval 25 mm. guns in the dimensions of the flange and the channel for the case extractor.

1. Shells for 25 mm. AA gun

Serial	Designation of shell	Index	Weight (Kg.)	Length with fuze (mm.)	Charge		Fuze	Colour coding
					Type	Weight (Kg.)		
1	Fragmentation incendiary tracer	OZR-132 N	0.281	100	Mixture tritol/hexogen/tetryl	0.012	B-23 or K-20	None
2	AP tracer	BR-132	0.295	112	None	-	None	None

Note: In fragmentation-incendiary-tracer shells the fuzes are fitted at the factory. Self-destruction of the fragmentation-incendiary-tracer round in the air is effected by means of the tracer.

2. Rounds for the 25 mm. AA gun

Serial	Designation of round	Index	Weight (Kg.)	Length (mm.)	Propellant Charge		Case		
					Type of powder	Weight (Kg.)	Weight (Kg.)	Length (mm.)	Primer type
1	Fixed round with fragmentation incendiary tracer shell	UOZR -132-N	0.650	292	6/7 or 6/7gr	0.1	0.275	219	KV-2 or ZTN
2	Fixed round with AP Tracer shell	UBR-132	0.684	292	ditto	0.1	0.275	219	"

3. Packaging of munitions for the 25 mm. AA gun

Serial	Type of munition	Quantity in box	Dimensions of box (cm.)	Weight of box (Kg.)	Remarks
1	Rounds with fragmentation incendiary tracer shells	54	67 x 38 x 17	45	
2	Rounds with AP tracer shells	30	52 x 48 x 15	30	

III. MUNITIONS FOR 25 mm. NAVAL GUN (FIGURE No. 2-5)

1. Shells for 25 mm. naval gun

Serial	Designation of shell	Index	Weight (Kg.)	Length with fuze (mm.)	Charge		Fuze	Colour coding
					Type	Weight (Kg.)		
1	Fragmentation incendiary tracer	-	0.246	100	Hexogen	0.012	B-23	Red band on shell

Note: With fragmentation incendiary tracer shells the fuzes are screwed in at the factory.

2. Rounds for 25 mm. naval gun

Serial	Designation of round	Index	Weight (Kg.)	Length (mm.)	Propellant Charge		Case			Colour coding
					Type of powder	Weight (Kg.)	Weight (Kg.)	Length (mm.)	Primer	
1	Fixed round with fragmentation incendiary tracer shell	-	0.637	292	7/14	0.094	0.262	219	KV -2 or ZTN	

Note: Rounds for this gun differ from those for the 25 mm. AA gun because the flange and channel in the case have different dimensions

3. Packaging for munitions for 25 mm. naval gun

Serial	Type of munition	Quantity	Dimensions of box (cm.)	Weight of box (Kg.)	Remarks
1	Rounds for 25 mm. naval gun	34	34 x 33 x 22	31	

Note: Rounds are packed in metallic cassettes.

IV. MUNITIONS FOR 30 mm. AIRCRAFT CANNON (FIGURES 2-6 TO 2-8)

1. Shells for 30 mm aircraft cannon

Serial	Designation of shell	Index	Weight (Kg.)	Length with fuze (mm.)	Charge		Fuze	Colour coding
					Type	Weight (Kg.)		
1	Fragmentation incendiary	-	0.335	100	Hexogen	0.056	A-30	Red band on cylinder section
2	Fragmentation incendiary-tracer	-	0.335	100	Hexogen	0.056	A-30	
3	AP-tracer	-	0.405	134	Hexogen	0.017	30-1	None

Note: Fuzes are fitted to the round in the factory.

2. Rounds for 30 mm. Aircraft cannon

Serial	Designation of round	Index	Weight (Kg.)	Length (mm.)	Propellant Charge		Case			Colour coding
					Type of gunpowder	Weight (Kg.)	Weight (Kg.)	Length (mm.)	Primer	
1	Fixed round with fragmentation incendiary shell	--	0.843	268	7/7	0.095	0.330	154	KV-2	
2	Fixed round with fragmentation incendiary tracer shell	--	0.843	268	7/7	0.095	0.330	154	KV-2	
3	Fixed round with AP shell	--	0.827	268	7/7	0.095	0.327	154	KV -2	

3. Packaging for munitions for 30 mm. Aircraft cannon

Serial	Type of munition	Quantity	Dimensions of box (cm.)	Weight of box (Kg.)	Remarks
1	Fixed round with fragmentation incendiary shell	36	76 x 37 x 14	47	
2	Fixed round with fragmentation incendiary-tracer shell	36	76 x 37 x 14	47	
3	Fixed round with AP shell	36	76 x 37 x 14	47	

V. MUNITIONS FOR 37 mm. AIRCRAFT CANNON (FIGURES 2-9 AND 2-10)

Rounds for the 37 mm. Aircraft cannon are of the fixed type, but differ from those used in the 37 mm. AA and naval guns by being shorter. The shells for the 37mm.Aircraft cannon are almost identical to those used in the 37 mm. AA and naval guns except for having different fuzes.

1. Shells for 37 mm. Aircraft cannon

Serial	Designation of shell	Index	Weight (Kg.)	Length with fuze (mm.)	Charge		Fuze	Colour coding
					Type	Weight (Kg.)		
1	Fragmentation-incendiary-tracer	--	0.735	174	Hexogen aluminium mixture	0.037	A-37 or MG-37	Red band
2	Solid AP-incendiary-tracer(with ballistic cap)	--	0.753	167	none	-	None	None

Note: Fuzes are fitted to the shell in the factory.

2. Rounds for 37 mm. Aircraft cannon

Serial	Designation of round	Index	Weight (Kg.)	Length (mm.)	Propellant Charge		Case			Colour coding
					Type of powder	Weight (Kg.)	Weight (Kg.)	Length (mm.)	Primer type	
1	Fixed round with fragmentation-incendiary-tracer shell	N-37 OZT	1.28	284 to 287	4/1 fl	0.127	0.390	155	KV-2 or ZTN	-
2	Fixed round with AP-incendiary-tracer shell	N-37 BZT	1.28	284 to 287	4/1 fl	0.127	0.390	155	KV-2 or ZTN	

3. Packaging of munitions for 37 mm. Aircraft cannon

Serial	Type of munition	Quantity in box	Dimensions of box (cm.)	Weight of box (Kg.)	Remarks
1	Rounds	20	73 x 38 x 10	38 to 43	
		30	89 x 37 x 30	56	

VI. MUNITIONS FOR 37 mm. GUNS (SINGLE BARREL 37 mm. AA GUN 1939 AND 1955 MODELS AND TWIN BARREL 1965 MODEL AND 37 mm. NAVAL GUN) (FIGURES 2-11 AND 2-12)

The rounds for these guns are identical, and so can be used in each of the above guns according to the fire-mission selected.

1. Shells for aircraft-mounted 37 mm. gun

Serial	Designation of shell	Index	Weight (Kg.)	Length with fuze (mm.)	Charge		Fuze	Colour coding
					Type	Weight (Kg.)		
1	Fragmentation-tracer	OR-167	0.732	155.4	Phlegmatised hexogen and powdered aluminium mixture	0.078	MG-37	None
2	Solid AP-tracer (with ballistic cap)	BR-167	0.758	155.4	none	-	None	None

2. Rounds for the 37 mm. naval gun and 37 mm. AA gun

Serial	Designation of round	Index	Weight (Kg.)	Length (mm.)	Propellant Charge		Case			Colour coding
					Type of gunpowder	Weight (Kg.)	Weight (Kg.)	Length (mm.)	Primer type	
1	Fixed round with fragmentation-tracer shell	UOR-167	1.48	385	7/14 or 7/7 or 6/7 fl	0.205 0.210	0.492	251	KV-2 or KV-2U or ZTN	None
2	Fixed round with AP-tracer shell	UBR-167	1.48	385	7/14 or 7/7 or 6/7 fl	0.205 0.210	0.492	251	KV-2 or KV-2U or ZTN	None

3. Packaging of munitions for the 37 mm. naval gun and 37 mm. AA gun

Serial	Type of munition	Quantity in box	Dimensions of box (cm.)	Weight of box (Kg.)	Remarks
1	Rounds with fragmentation-tracer shell	30	65 x 45 x 23	57	
2	Rounds with AP tracer shell	30	65 x 45 x 23	58	
3	MG – 37 fuzes	168	51 x 46 x 14	42	

VII. MUNITIONS FOR 45 mm. GUNS (45 mm. ANTI-TANK GUN 1937 AND 1942 MODELS AND 45 mm. NAVAL GUN (FIGURES 2-13 TO 2-18.)

Munitions for these guns are identical: rounds can be used in any of the guns depending on the fire-mission selected. The round with the AA-fragmentation shell is used only on the naval gun. 45 mm. rounds are fixed-type.

1. Shells for 45 mm. guns

Serial	Designation of shell	Index	Weight (Kg.)	Length without fuze (mm.)	Charge		Fuze	Colour coding
					Type	Weight Kg.		
1	Short-range fragmentation	0-240	2.14	207	Tritol or amatol	0.118	KTM-1U or KTM-1	-
2	AP-tracer	BR-240	1.43	171	Phlegmatised hexogen	0.018	MD-5	-
3	AP-incendiary-tracer	BZR-240	1.43	171	Phlegmatised hexogen + powdered aluminium	0.012 0.013	MD-5	Single red ring
4	Sub-calibre AP	BR-240P	0.87	122	None	-	-	None
5	AA fragmentation	-	1.43	171	Hexogen and aluminium mixture	0.118	MG-37	-
6	Practice-tracer	PBR-240	1.43	171	None	--	None	-

Note: AA-fragmentation shells are only used in naval guns.

2. Rounds for 45 mm. guns

Serial	Designation of round	Index	Weight (Kg.)	Length (mm.)	Propellant Charge		Case			Colour coding
					Type of powder	Weight (Kg.)	Weight (Kg.)	Length (mm.)	Primer type	
1	Fixed round with short-range fragmentation-shell	UO-243	2.6	450	4/1 or 7/1	0.10	0.61	310	ZTN or KV-4	-
2	Fixed round with AP-tracer shell	UBR-243	2.5	450	7/7 or 8/7	0.36	0.61	310	ZTN or KV-4	-
3	Fixed round with AP-incendiary-tracer shell	UBZR-243	2.5	450	7/7 or 8/7	0.36	0.61	310	ZTN or KV-4	-
4	Fixed round with AP sub-calibre shell	UBR-243P	2.5	420	7/7 or 8/7	0.38	0.61	310	ZTN or KV-4	-
5	Fixed round with AA fragmentation-shell for naval guns	-	2.5	450	7/7 or 8/7	0.38	0.61	310	ZTN or KV-4	-
6	Fixed round with practice tracer shell	UPBR-243	2.5	450	4/1	0.38	0.61	310	ZTN or KV-4	-

Note: AA-fragmentation rounds are only used in naval guns

3. Packaging of munitions for 45 mm. guns

Serial	Type of munition	Quantity in box	Dimensions of box (cm.)	Weight of box (Kg.)	Remarks
1	Rounds with fragmentation shell	10	53 x 39 x 19	39	
2	Rounds with AP-tracer shell or AP-incendiary-tracer shell	10	53 x 39 x 19	39	
3	Rounds with sub-calibre AP tracer shell	10	53 x 39 x 19	39	
4	KTM-1 and KTM –1U fuzes	80	51 x 46 x 15	43	
5	MG – 37 fuzes	168	51 x 46 x 14	42	

VIII. MUNITIONS FOR 57 mm. AA GUN, 1958 MODEL (FIGURES 2-19 AND 2-20)

This gun uses fixed rounds.

1. Shells for 57 mm. AA gun

Serial	Designation of shell	Index	Weight (Kg.)	Length without fuze (mm.)	Charge		Fuze	Colour coding
					Type	Weight (Kg.)		
1	Fragmentation-tracer, AA	0R-281	2.8	176.7	Mixture of phlegmatised hexogen with powdered aluminium	0.153	MG-57	None
2	AP-tracer	BR-281	2.8	176.7	Mixture of phlegmatised hexogen with powdered aluminium	0.020	MD-10	None

2. Rounds for the 57 mm. AA gun

Serial	Designation of round	Index	Weight (Kg.)	Length (mm.)	Propellant Charge		Case			Colour coding
					Type of powder	Weight (Kg.)	Weight (Kg.)	Length (mm.)	Primer type	
1	Fixed round with fragmentation-tracer AA shell	UOR-281	6.61	540	11/7 fl	1.2	2.420	348	KV-5 or KV5-U	None
2	Fixed round with AP-tracer shell	UBR-281	6.61	540	11/7 fl	1.2	2.420	348	KV-5 or KV-5U	None

3. Packaging of munitions for the 57 mm. AA gun

Serial	Type of munition	Quantity in box	Dimensions of box (cm.)	Weight of box (Kg.)	Remarks
1	Rounds for 57 mm. AA gun	5	65 x 58 x 17	48	

Note: Fixed rounds with fragmentation shell also use the MGZ-57 fuze. This fuze differs from the MG-57 only in that its firing pin is not of wood but aluminium. The MGZ-57 has a cap whereas the MG-57 does not.

IX. MUNITIONS FOR 76 mm. GUNS (76 mm. FIELD GUN 1942 MODEL (MOD 54) 76 mm. SP GUN AND 76 mm. REGIMENTAL GUN 1943 MODEL) (FIGURES 2-21 TO 2-30)

These guns use fixed rounds, and the shells are identical for all. The rounds for the 1943 model regimental gun are shorter, while the 76 mm. field gun and the SP version use the same rounds. Rounds for the SP gun are fitted only with the KTM 1-U fuze.

1. Shells for 76 mm. guns

Serial	Designation of shell	Index	Weight (Kg.)	Length without fuze (mm.)	Charge		Fuze	Colour coding
					Type	Weight (Kg.)		
1	Cast-iron fragmentation	0-350-A	6.2	304	Tritol or amatol	0.54	KTM-1U or KTM-1	Single black ring
2	HE-fragmentation	OF-350	6.2	304	Tritol or amatol	0.71	KTM-1U or KTM-1	-
3	Shaped charge (HEAT)	BP-350 M	3.94	319	Tritol or mixture of tritol and hexogen	0.623	BM	Black nose
4	AP-tracer with nose shaped as illustrated <i>(see figure 2-27, page 187)</i>	BR-350A	6.3	319	Mixture of phlegmatized hexogen with powdered aluminium	0.155	MD-7	-
5	AP-tracer with flat nose	BR-350B	6.5	274	Mixture of phlegmatized hexogen with powdered aluminium	0.119	MD-7 or MD-8	-
6	Solid AP	BR-350SP	6.5	266	None	-	None	None
7	AP sub-calibre	BR-350P	3.02	175	None	-	None	None

2. Rounds for 76 mm. field gun 1954 model (mod 1942) and 76 mm. SP gun

Serial	Designation of round	Index	Weight (Kg.)	Length (mm.)	Propellant Charge		Case			Colour coding
					Type of powder	Weight(Kg.)	Weight (Kg.)	Length (mm.)	Primer type	
1	Fixed round with fragmentation shell	UO-354A	8.83	620	9/7 or 9/7 OD	1.080	1.69	384	KV-4	-
2	Fixed round with fragmentation shell and Reduced Charge	UO-353	8.2	620	4/1	0.455	1.69	384	KV-4	Single black ring on case
3	Round with HE-fragmentation shell	UOF-354M	8.84	620	9/7 or 9/7 OD or 8/7 OD	1.080	1.69	384	KV-4	-
4	Round with AP shell with nose shaped as illustrated in <i>Figure 2-27, page 187</i>	UBR-354A	9.07	635	9/7	1.080	1.69	384	KV-4	-
5	Round with AP shell with flat nose	UBR-354B	9.27	590	9/7	1.080	1.69	384	KV-4	-
6	Round with solid AP shell	UBR-354SP	9.27	620	9/7	1.080	1.69	384	KV-4	
7	Round with AP- sub-calibre shell	UBR-354-P	5.8	530	9/7	1.3	1.69	384	KV-4	

3. Rounds for the 76 mm. regimental gun 1943 model

Serial	Designation of round	Index	Weight (Kg.)	Length (mm.)	Propellant Charge		Case			Colour coding
					Type of powder	Weight(Kg.)	Weight (Kg.)	Length(mm.)	Primer type	
1	Round with fragmentation shell	UO-344	7.36	376	4/1 or 5/1	0.15	1.0	165	KB-4	
2	Round with HE-fragmentation shell	UOF-344	7.36	376	4/1 or 5/1	0.15	1.0	165	KB-4	
3	Round with shaped charge (HEAT)shell	UBP-344-	5.09	376	4/1 or 5/1	0.15	1.0	165	KB-4	

4. Packaging of munitions for 76 mm. guns

Serial	Type of munition	Quantity in box	Dimensions of box (cm.)	Weight of box (Kg.)	Remarks
1	Rounds for 76 mm. regimental gun 1943 model	5	81 x 52 x 16	51	Boxes with shaped charge (HEAT) rounds weigh 47 Kg.
2	Rounds for 76 mm. field gun 1954 model (1942) and 76 mm. SPG	5	80 x 54 x 15	59	Boxes with sub-calibre AP rounds weigh 44 Kg.
3	KTM-1 and KTM-1U fuzes	80	52 x 46 x 15	43	

Note: In boxes of Chinese-manufactured rounds the fuzes are also included, placed in hermetically sealed metal boxes.

X. MUNITIONS FOR 85 mm. GUNS (85 mm. FIELD GUN 1956 MODEL, 85 mm. TANK-MOUNTED GUN , 85 mm. AA GUN 1939 MODEL AND 85 mm. NAVAL GUN) (FIGURES 2-31 TO 2-38)

Munitions for these guns are identical, and so can be used in any gun, dependent on the task. Rounds with AA shells are used only in AA guns and naval guns. 85 mm. rounds are fixed-type.

1. Shells for 85 mm. guns

Serial	Designation of shell	Index	Weight (Kg.)	Length without fuze (mm.)	Charge		Fuze	Colour coding
					Type	Weight (Kg.)		
1	Fragmentation, steel	O-365K	9.54	340	Tritol or amatol	0.74	KTM-1-U MGN KTMZ-1-U	
2	Fragmentation, cast-iron	O-367A	9.54	357	Tritol or amatol	0.67	ditto	Single black ring on shell
3	Fragmentation, AA with airburst fuze	O-365	9.2	215	Tritol with a quantity of smoke generator	0.67	VM-30 VM-30LI T-5	
<i>Note: This shell is used only in AA and naval guns</i>								
4	Sharp-nosed AP-tracer	BR-365K	9.34	263	Mixture of phlegmatized hexogen with powdered aluminium	0.048	MD-8	-
5	AP-tracer with flat nose and ballistic cap	BR-365	9.2	365	Mixture of phlegmatized hexogen with powdered aluminium	0.164	MD-7	-
6	AP-tracer with blunt nose and ballistic cap	BR-367	9.2	306	ditto	-0.044	MD-8	
7	AP-tracer sub-calibre	BR-365P	4.99 or 5.35	255	None	--	None	

2. Rounds for 85 mm. guns

Serial	Designation of round	Index	Weight (Kg.)	Length (mm.)	Propellant Charge		Case			Colour coding
					Type of powder	Weight (Kg.)	Weight (Kg.)	Length (mm.)	Primer type	
1	Round with steel fragmentation shell with Full Charge	UO-365K	15	845	14/7 + 18/1tr +8/1Ug or 14/7 +18/1tr	2.6	3.79	627	KV-4	-
2	Round with steel fragmentation shell and Reduced Charge	UO-367	15	900	9/7	1.66	3.79	627	KV-4	Single black ring on case
3	Round with cast-iron fragmentation shell and Reduced Charge	UOF-367A	15	900	9/7	1.6	3.79	627	KV-4	ditto
4	Round with AA fragmentation airburst shell Note: only AA and naval guns use this round	UO-365	15.9	900	14/7 + 18/1tr +8/1Ug or 14/7 +18/1tr	2.6	3.79	627	KV-4	-
5	Round for sharp-nosed AP shell	UBR-365K	15.6	830	14/7 + 18/1tr	2.6	3.79	627	KV-4	-
6	Round with AP-tracer shell with blunt nose and ballistic cap	UBR-365	15.842	830	14/7 +18/1tr	2.6	3.79	627	KV-4	-
7	Round with AP-tracer shell with AP nose and ballistic cap	UBR-367	15.842	830	14/7 +18/1tr	2.67	3.79	627	KV-4	-
8	Round with AP-tracer-sub-calibre shell	UBR-367-P	11.632	860	12/7 or 14/7	2.85	3.79	627	KV-4	-

Note:

1. The round with AA fragmentation shell is used only in AA and naval guns.
2. As well as the types of gunpowder shown in the table the following types may be found in 85 mm. rounds:
 1. 12/7 OD +NDT-2 16/1
 2. NDT-3 14/7
 3. 12/7 OD + 18/1tr
 4. 14/7 OD + 18/1tr
 5. 12/7 OD + WM 130/30.5

6. 14/7 OD + WM 130/30.5
7. 12/7 OD + WMT 211/100/25.5
8. 14/7 OD + WMT 211/100/25.5
9. 12/7 OD + 17/10D
10. 14/7 OD + 17/10D
11. 14/7
12. 12/7 + WM +WMT
13. NDT-3 14/1
14. NDT 3 17/1

3. Packaging of munitions for 85 mm. guns

Serial	Type of munition	Quantity in box	Dimensions of box cm.	Weight of box Kg.	Remarks
1	85 mm. rounds	2	102 x 30 x 16	42	
		3	85 x 63 x 23	58	Boxes with sub-calibre rounds weigh 46 Kg.
		4	110 x 54 x 20	80	Boxes with sub-calibre rounds weigh 63 Kg.
2	KTM-1-U fuzes	80	52 x 46 x 15	43	
3	MGN fuzes	80	52 x 46 x 15	43	

Note: In some of the rounds boxes the appropriate fuzes are included, packed in hermetically sealed boxes.

XI. MUNITIONS FOR 100 mm. GUNS (100 mm. FIELD GUN 1954 MODEL (1944); 100 mm. AA GUN 1959 MODEL, 100 mm. TANK-MOUNTED AND SP GUN, 100 mm. COASTAL ARTILLERY GUN WITH MECHANICAL EXTRACTION) (FIGURES 2-39 TO 2-48.)

100 mm. rounds are fixed-type. The 100 mm. field gun, and the tank-mounted and SP 100 mm. gun use the same munitions. The 100 mm. AA gun, as well as the AA round with fragmentation shell, can use all the same rounds as the 100 mm. field gun and tank-mounted and SP gun, for firing at ground and sea targets. The 100 mm. coastal artillery gun with mechanical extraction uses, apart from its own rounds, the round with HE-fragmentation shell as used in the 100 mm. field gun and the tank-mounted and SP gun.

1. Shells for 100 mm. field gun and tank-mounted and SP gun

Serial	Designation of shell	Index	Weight (Kg.)	Length without fuze (mm.)	Charge		Fuze	Colour coding
					Type	Weight (Kg.)		
1	HE –fragmentation	OF-412	15.6	429	Tritol or amatol	1.46	RGM RGM-6 V-429	
2	AP-tracer with blunt nose and ballistic cap	BR-412B	15.88	360	Mixture of phlegmatised hexogen with powdered aluminium	0.065	MD-8	
3	AP-tracer with sharp nose	BR-412	15.88	308	ditto	0.065	MD-8	-
4	Practice tracer	PBR-412	15.88	308	None	-	None	Black colour

2. Shells for 100 mm. AA gun

Serial	Designation of shell	Index	Weight (Kg.)	Length without fuze (mm.)	Charge		Fuze	Colour coding
					Type	Weight (Kg.)		
1	Fragmentation airburst with distance fuze	O-415	15.6	400	Tritol with a quantity of smoke generator	1.4	VM-30 or VM-30L1	

3. Shells for 100 mm. coastal artillery gun with mechanical extraction

Serial	Designation of shell	Index	Weight (Kg.)	Length without fuze (mm.)	Charge		Fuze	Colour coding
					Type	Weight (Kg.)		
1	HE	FB-56	15.8	520	Tritol	1.46	ZMR	
2	Fragmentation with distance fuze	ZB-56	15.6	510	Tritol or stronger explosive	1.2	VM-16 or VM-16 M	
3	Practice	PJa-56	15.8	370	None	-	None	Body of shell coloured black
4	Illuminating	SB-56	15.8	510	Illuminating material Gunpowder with smoke	1.55 0.01	T-66 or MT-6	Body of shell coloured white

4. Rounds for 100 mm. field gun and 100 mm. tank-mounted and SP gun

Serial	Designation of round	Index	Weight (Kg.)	Length (mm.)	Propellant Charge		Case			Colour coding
					Type of powder	Weight(Kg.)	Weight (Kg.)	Length (mm.)	Primer type	
1	Round with HE fragmentation shell with Full Charge	UOF-412	29.6	1030	NDT-3 18/1 or 100/56 or NT-3 18/1 or DGT-3	5.5 5.3 5.5 5.5	8.5	693	KV-13	-
2	Round with HE fragmentation shell with Reduced Charge	UOF-412U	26.5	1030	9/7 or 12/7 or 9/7 OD+ 75/50 or 9/7 OD + +WMT211/100/ 26.5	2.4 2.47 2.44	8.5	693	KV-4	Single black ring on case
3	Round with AP tracer shell with blunt nose and ballistic cap	UBR-412B	29.8	961	NDT-3 18/1 or NT-3 18/1 or 100/56	5.5 5.5 5.3	8.5	693	KV-13	-
4	Round with fragmentation-tracer shell with sharp nose	UBR-412	29.6	909	NDT-3 18/1 or NT-3 18/1 or 100/56 or DGT-3	5.5 5.5 5.3 5.5	8.5	693	KV-13	-
5	Round with practice tracer shell with Reduced Charge	UPBR-412	26.7	909	9/7 or 12/7 +12/1g	2.47	8.5	693	KV-4	Single black ring on case

5. Rounds for 100 mm. AA gun (1959 model)

Serial	Designation of round	Index	Weight (Kg.)	Length (mm.)	Propellant Charge		Case			Colour-coding
					Type of gunpowder	Weight (Kg.)	Weight (Kg.)	Length(mm.)	Primer type	
1	Round with fragmentation shell with distance fuze	UO-415	29.8	1030	NDT-3 18/1 or NT-3 18/1 or DGT-3	5.5	8.5	693	KB-13	-

Note: In this gun all rounds designated for the field gun and the tank-mounted and SP gun can be used for firing against ground targets.

6. Rounds for 100 mm. coastal artillery gun with mechanical extraction

Serial	Designation of round	Index	Weight (Kg.)	Length (mm.)	Propellant Charge		Case			Colour coding
					Type of gunpowder	Weight (Kg.)	Weight (Kg.)	Length (mm.)	Primer type	
1	Round with HE shell with Full Charge	UFSB-56	29.8	1012	100/56	5.3	8.5	693	KV-13	-
2	Round with fragmentation airburst shell and Full Charge	UZSB-56	29.1	1012	100/56	5.3	8.5	693	KV-13	-
3	Round with HE-fragmentation shell with Full Charge	UOF-412	26.5	1030	NDT-3 18/1 or 100/56 or NT-3 18/1 or DGT-3	5.5 5.3 5.5 5.5	8.5	693	KV-13	-
4	Round with practice shell with Reduced Charge	UPSB-56	26.7	1012	75/56	2.5	8.5	693	KV-4	Single black ring on case
5	Round with illuminating shell	SB-56	29.8	1012	100/56	5.3	8.5	693	KV-13	White shell

Note: The UOF-412 round is the one which is used in the 100 mm. field gun and the tank-mounted and SP 100 mm. gun.

7. Packaging of munitions for 100 mm. guns

Serial	Type of munition	Quantity in box	Dimensions of box (cm.)	Weight of box (Kg.)	Remarks
1	Rounds	1	121 x 20 x 20	42	Boxes with Reduced Charge rounds weigh 70 Kg.
		2	122 x 41 x 23	75	
2	RGM or RGM-6 fuzes	64	51 x 46 x 14	44	
3	V-429 fuzes	64	51 x 46 x 14	44	
4	VM-30 or VM-30 L1 fuzes	36	53 x 50 x 22	48	

Note: In some of the rounds boxes the appropriate fuzes are included, packed in hermetically sealed boxes.

XII. MUNITIONS USED IN 122 mm. HOWITZER 1954 MODEL (1938) (FIGURES 2-49 TO 2-58)

The 1938 and 1954 models of the 122 mm. howitzer use the same munitions

With 122 mm. howitzers the propellant charge is placed in a special case

1. Shells for 122 mm. howitzer

Serial	Designation of shell	Index	Weight (Kg.)	Length without fuze (mm.)	Charge		Fuze	Colour coding
					Type	Weight (Kg.)		
1	HE -fragmentation	OF-462	21.76	500	Tritol or amatol	3.528	RGM-2 D-1-U	
2	Fragmentation with single piece cast-iron body	O-460A	21.76	451	Tritol or amatol	1.984	RGM-2 D-1-U	Single black band
3	Fragmentation with cast iron body and threaded head section	O-462A	21.76	451	Tritol or amatol	1.984	RGM-2 D-1-U	Single black band
4	Shaped charge HEAT, cast-iron	BP-460A	13.34	329	Tritol or stronger explosive	1.450	V-229	Single black band
5	Shaped charge, HEAT steel	BP-463	14.8	329	Tritol or stronger explosive	2.950	GKV	-
6	Smoke, steel	D-462	22.55	500	Smoke generator + tritol	3.635	KTM-2	-
						0.160		
7	Smoke, cast-iron	D-462A	22.77	476	Smoke generator + tritol	2.545	RGM-2	
						0.181		
8	Illuminating	S-463	22.0	427	Illuminating material	0.100 of black gunpowder	T-7	Single white band
9	Illuminating	S-462	22.3	427	Illuminating material	ditto	T-6	Single white band

2. Propellant charges for 122 mm. howitzer

Serial	Designation of charge	Type of gunpowder	Weight of gunpowder (Kg.)	Composition of charge	Case			Used with shells as below
					Weight (Kg.)	Length (mm.)	Primer type	
1	Full Charge	4/1 + 9/7	2.20	Base bag + 4 lower bags + 4 upper bags	2.98	285	KV-4	OF-462, O-460A, D-462, BP-463, S-463
2	Charge No.1	4/1 + 9/7	1.875	Base bag + 4 lower bags + 3 upper bags	2.98	285	KV-4	O-462A, D-462A, S-462
3	Charge No. 4	4/1 + 9/7	0.8	Base bag + 4 lower bags	2.98	285	KV-4	BP-460

Note: The approximate weight of the gunpowder in the base bag is 0.34 Kg., in each upper bag 0.325 Kg. and in each lower bag 0.115 Kg.

The various charges are made up by the removal of chargebags as follows:

Full Charge: Only the hermetic cover is removed.

- Charge No. 1: 1 upper chargebag and the hermetic cover are removed.
- Charge No.2: 2 upper chargebags and the hermetic cover are removed.
- Charge No.3: 3 upper chargebags and the hermetic cover are removed.
- Charge No.4: 4 upper chargebags and the hermetic cover are removed.
- Charge No. 5: 4 upper chargebags, 1 lower chargebag and the hermetic cover are removed.
- Charge No.6: 4 upper chargebags, 2 lower chargebags and the hermetic cover are removed.
- Charge No.7: 4 upper chargebags, 3 lower chargebags and the hermetic cover are removed.
- Charge No.8: 4 upper chargebags, 4 lower chargebags and the hermetic cover are removed.

Note: After extraction of the hermetic cap and removal of the specified quantity of chargebags the chargebags which remain are placed in a suitable position and are held there by the normal cap.

3. Packaging of munitions for 122 mm. howitzer

Serial	Type of munition	Quantity in box	Dimensions of box (cm.)	Weight of box (Kg.)	Remarks
1	Rounds	1	57 x 32 x 18	35	Boxes with shaped charge rounds weigh 27 Kg.
		2	76 x 49 x 19	68	Boxes with shaped charge rounds weigh 51 Kg.
2	RGM-2 fuzes	64	51 x 46 x 14	44	
3	D-1-U fuzes	80	49 x 49 x 24	64	
4	V-229 fuzes	120	52 x 46 x 15	24	

Note:

1. The rounds are put into the boxes fully assembled (shells with the appropriate propellants)
2. In some of the rounds boxes the appropriate fuzes are included, packed in hermetically sealed boxes.

XIII. MUNITIONS FOR 122 mm. GUN 1960 MODEL. (FIGURES 2-59 TO 2-61)

Rounds for the 122 mm. gun have the propellant placed in a special case.

1. Shells for 122 mm. gun.

Serial	Designation of shell	Index	Weight (Kg.)	Length without fuze (mm.)	Charge		Fuze	Colour coding
					Type	Weight (Kg.)		
1	HE -fragmentation	OF-472	27.3	622	Tritol or amatol	3	V-429 or RGM-6	-

2. Propellant charges for 122 mm. gun

Serial	Designation of charge	Type of gunpowder	Weight of gunpowder (Kg.)	Composition of charge	Case			Colour-coding
					Weight (Kg.)	Length (mm.)	Type of gunpowder (<i>sic: primer?</i>)	
1	Full Charge	NDT 19/1	9.8	Invariable	10.10	760	KV-5	
2	Reduced Charge	12/1 Tr + 13/7	6.53	Base bag + 2 equal bags	10.10	760	KV-5	Black band on case

Note: The approximate weight of the gunpowder in the Reduced Charge is 3.75 Kg., whereas that of each supplementary bag is 1.39 Kg.

The various charges are made up by removal of the chargebags, as follows:

Full Charge: Only the hermetic cap is removed.

Charge No.1 Only the hermetic cap is removed from the Reduced Charge (denoted by black ring on case).

Charge No. 2: The hermetic cap and one chargebag are removed from the Reduced Charge.

Charge No. 3: The hermetic cap and two chargebags are removed from the Reduced Charge.

Note: Sometimes the cases with Reduced Charge are marked as "Charge No. 1." In some cases rounds are assembled with Charge 2 in the factory.

3. Packaging of munitions for the 122 mm. gun

Serial	Type of munition	Quantity in box	Dimensions of box (cm.)	Weight of box (Kg.)	Remarks
1	Rounds with Full Charge	1	85 x 44 x 24	56	
2	Rounds with Reduced Charge	1	85 x 44 x 24	50	

XIV. MUNITIONS FOR 130 MM. COASTAL ARTILLERY GUN WITH MECHANICAL EXTRACTION (FIGURES 2-62 TO 2-66).

Rounds for the 130 mm. coastal artillery gun with mechanical extraction have the propellant charge in a special case.

1. Shells for 130 mm. coastal artillery gun with mechanical extraction.

Serial	Designation of shell	Index	Weight (Kg.)	Length without fuze (mm.)	Charge		Fuze	Colour coding
					Type	Weight (Kg.)		
1	Semi AP	PB-42	33.4	608	Tritol or stronger explosive	0.8	V-350	-
2	HE –fragmentation	OF-42	33.4	615	Tritol or amatol	3.64	VGU-1	-
3	AA –fragmentation	OF/ZS	32.67	623	Tritol or mixture of tritol and hexogen	3.5	VM-60	-

2. Propellant charges for 130 mm. coastal artillery gun with mechanical extraction

Serial	Designation of charge	Type of gunpowder	Weight of gunpowder (Kg.?)	Composition of charge	Case			Used with shells as listed
					Weight (Kg.)	Length (mm.)	Type of primer	
1	Full Charge	130/58 BP	15.3	Invariable	12.4	991	UV-4	With all three types of shells
2	Reduced Charge (indicated by black ring on case)	130/58 BPSH	8.5	Invariable	12.4	991	KV-4	Only with semi-AP and HE-fragmentation shells

3. Packaging of munitions for 130 mm. coastal artillery gun with mechanical extraction

Serial	Type of munition	Quantity in box	Dimensions of box (cm.)	Weight of box (Kg.)	Remarks
1	Shells	2	88 x 50 x 20	80	
2	Propellants	2	116 x 45 x 27	81	
3	VGU-1 fuzes	18	49 x 27 x 24	38	
4	VM-60 fuzes	36	53 x 50 x 22	42	
5	V-350 fuzes	40	51 x 47 x 14	41	

XV. MUNITIONS FOR 130 mm. COASTAL ARTILLERY GUN (SEPARATE-LOADING) (FIGURES 2-67 TO 2-70)

Rounds for the 130 mm. static coastal artillery gun have the propellant charge placed in a chargebag (without case). The primer is peculiar to this round. Loading of the gun is carried out in three phases: first the shell is placed in the breech, then the chargebag and lastly the primer.

1. Shells for 130 mm. coastal artillery gun (separate loading)

Serial	Designation of shell	Index	Weight (Kg.)	Length without fuze (mm.)	Charge		Fuze	Colour coding
					Type	Weight (Kg.)		
1	HE –fragmentation	OF/ZS-46	33.4	600	Tritol or amatol	3.64	RGM or RGM-6	-
2	Semi AP	PB-46	33.4	600	Tritol or stronger explosive	0.8	2MR	

Note: The 2MR fuze is fitted to the shell in the factory.

2. Propellant charges for 130 mm. coastal artillery gun (separate loading)

Serial	Designation of charge	Type of gunpowder	Weight of gunpowder Kg.	Composition of charge	Type of primer	Used in the shells listed
1	Full Charge	130/50	11.665	Invariable	UTK-36 (mechanical) or GT-2 (electrical)	With both types of shells
2	Reduced Charge (indicated by black ring on case)	130/50	5.345	Invariable	UTK-36 (mechanical) or GT-2 (electrical)	With both types of shells

3. Packaging of munitions for 130 mm. coastal artillery gun (separate loading)

Serial	Type of munition	Quantity in box	Dimensions of box (cm.)	Weight of box (Kg.)	Remarks
1	Shells	2	88 x 50 x 20	80	
2	Propellants	4	110 x 50 x 40	92	
3	RGM fuzes	64	51 x 46 x 14	44	
4	RGM-6 fuzes	64	51 x 46 x 14	44	

XVI. MUNITIONS FOR 130 mm. FIELD GUN (1959 AND 1959-1 MODELS) (FIGURES 2-71 TO 2-74)

The 1959 and 1959-1 models of the 130 mm. field gun use the same munitions. The rounds for 130 mm. field guns have the propellant charge placed in special cases.

1. Shells for 130 mm. field gun (1959 model) and 130 mm. field gun (1959-1 model)

Serial	Designation of shell	Index	Weight (Kg.)	Length without fuze (mm.)	Charge		Fuze	Colour coding
					Type	Weight (Kg.)		
1	HE -fragmentation	OF-482M	33.4	611	Tritol or amatol	3.64	RGM-6 or V-429	-
2	Practice	-	33.4	611	Inert substance	3.64	dummy	Shell is black, with white band on the fuze

2. Propellant charges for 130 mm. field gun (1959 model) and 130 mm. field gun (1959-1 model)

Serial	Designation of charge	Type of gunpowder	Weight of gunpowder (Kg.)	Composition of charge	Case		
					Weight (Kg.)	Length (mm.)	Type of primer
1	Full variable charge with index no. ZhN-482	NDT-3 23/1 or Dg-3 23/1	13.2	Lower group of bags + upper bag	11.250	845	KV-5
2	Reduced variable charge with index no. ZhN-482U	12/1 + 9/7 or 12/1 tr + 9/7	6.5	Base bag and two chargebags of identical weight	11.250	845	KV-5

Note: The approximate weight of the gunpowder is as follows: with Full Charge the lower group weighs 11.5 Kg. and the upper 1.7 Kg., while with the Reduced Charge the base bag weighs 3.9 Kg. and each supplementary bag 1.3 Kg.

The various charges are made up as follows:

Full Charge: Only the hermetic cap is removed from the full variable charge.

Charge No. 1: The hermetic cap and the upper bag are removed from the full variable charge.

Charge No. 2: Only the hermetic cap is removed from the reduced variable charge.

Charge No. 3: The hermetic cap and one upper bag are removed from the reduced variable charge.

Charge No. 4: The hermetic cap and the two upper bags are removed from the reduced variable charge.

Note: In the reduced variable charge each upper bag consists of two parts sewn together.

3. Packaging of munitions for 130 mm. field gun (1959 model) and 130 mm. field gun (1959-1 model)

Serial	Type of munition	Quantity in box	Dimensions of box (cm.)	Weight of box (Kg.)	Remarks
1	Rounds with Full Charge	1	562 x 95 x 44	80	The rounds are placed in the boxes fully assembled with all components (shell, propellant charge and fuze)
2	Rounds with Reduced Charge	1	562 x 95 x 44	75	

XVII. MUNITIONS FOR 152 mm. GUN AND GUN-HOWITZER (FIGURES 2-75 TO 2-87)

152 mm. rounds have the propellant charge placed in a special case.

152 mm. rounds are of two kinds: howitzer rounds and gun-howitzer rounds. Howitzer rounds are shorter than gun-howitzer rounds and weigh 40 Kg. whereas gun-howitzer rounds are longer and weigh over 43 Kg. The 152 mm. howitzer can use only howitzer rounds, whereas the gun-howitzer can use both howitzer and gun-howitzer rounds.

1. Shells for 152 mm. howitzer

Serial	Designation of shell	Index	Weight (Kg.)	Length without fuze (mm.)	Charge		Fuze	Colour coding
					Type	Weight (Kg.)		
1	HE –fragmentation, steel	OF-530	40	608	Tritol or amatol	5.83	RGM-2 or D-1U	-
2	Fragmentation, cast-iron	O-530 A	40	608	Tritol or amatol	5.66	RGM-2 or D-1U	Single black ring on shell
3	Concrete-piercing	G-530	40	593	Tritol	5.10	KTD	Single blue ring on shell

Note: RGM, RGM-3 and RGM-8 fuzes can also be used on the HE and HE-fragmentation rounds.

2. Shells for 152 mm. gun-howitzers

Serial	Designation of shell	Index	Weight (Kg.)	Length without fuze (mm.)	Charge		Fuze	Colour coding
					Type	Weight (Kg.)		
1	HE –fragmentation	OF-540	43.56	638	Tritol or amatol	6.25	RGM, V-429 D-1-U	
2	Concrete-piercing tracer	BR-540	48.78	593	Tritol mixed with phlegmatised hexogen	1.2	MD-7	

Note:

1. These shells may be used only in 152 mm. gun-howitzers. Use of gun-howitzer rounds in the howitzer is forbidden, because this may cause destruction of the barrel or premature explosion of the shell.
2. The 1966 model gun-howitzer is used only with the OF-540 shell, whereas the 37 model gun-howitzer uses both these shells, as well as rounds for the 152 mm. howitzer.

3. Propellant charges for 152 mm. howitzer

Serial	Designation of charge	Type of gunpowder	Weight of gunpowder (Kg.)	Composition of charge	Case			Used with shells as below
					Weight (Kg.)	Length (mm.)	Primer type	
1	Full Charge Zh-356	4/1 + 12/7	3.62	Base bag + 4 lower bags + 4 upper bags	4.55	340	KV-4	OF-530 and O-530 A
2	Charge No. 1 Zh-356	4/1 + 12/7	3.09	Base bag + 4 lower bags + 3 upper bags	4.55	340	KV-4	G-530
3	Charge No. 3 Zh-356	4/1 + 12/7	2.03	Base bag + 4 lower bags + 1 upper bag	4.55	340	KV-4	OF-530 and O-530 A

Note: The approximate weights of the gunpowder are: base bag 0.640 Kg., upper bag 0.530 Kg., and lower bag 0.215 Kg.

The various charges are made up by removal of chargebags as follows:

- Full Charge: Only the hermetic cap is removed.
- Charge No.1: The hermetic cap and 1 upper charge bag are removed.
- Charge No.2: The hermetic cap and 2 upper chargebags are removed.
- Charge No.3: The hermetic cap and 3 upper chargebags are removed.
- Charge No.4: The hermetic cap and 4 upper chargebags are removed.
- Charge No.5: The hermetic cap, 4 upper chargebags and 1 lower chargebag are removed.
- Charge No.6: The hermetic cap, 4 upper chargebags and 2 lower chargebags are removed.
- Charge No.7: The hermetic cap, 4 upper chargebags and 3 lower chargebags are removed.
- Charge No.8: The hermetic cap, 4 upper chargebags and 4 lower chargebags are removed.

4. Propellant charges for 152 mm. gun-howitzer 1966 model

Serial	Designation of charge	Type of gunpowder	Weight of gunpowder (Kg.)	Composition of charge	Case			Used with shells as below
					Weight (Kg.)	Length (mm.)	Primer type	
1	Full Charge	NDT-3 16/1 + 8/1	8.69	Lower group + upper group + 2 bags of equal weight	7.65	546	KV-4	OF-540
2	Charge No.2	9/7 4/1 8/1	4.13	Base bag + 5 supplementary bags of equal weight	7.65	546	KV-4	OF-540

The approximate weights of the gunpowder in the Full Charge are: in the two groups combined 8.0 Kg., in each supplementary bag 0.345 Kg., whereas in Charge No. 2 the base bag weighs 1.282 Kg. and each supplementary bag 0.570 Kg.

The charges are made up as follows:

- Full Charge: Only the hermetic cap is removed.
- Charge No 1: The two bags of equal weight are removed from the Full Charge.
- Charge No. 2: Only the hermetic cap is removed from Charge No. 2.
- Charge No. 3: 1 supplementary bag is removed from Charge No. 2.
- Charge No. 4: 2 supplementary bags are removed from Charge No. 2.
- Charge No. 5: 3 supplementary bags are removed from Charge No. 2.
- Charge No. 6: 4 supplementary bags are removed from Charge No. 2.
- Charge No. 7: 5 supplementary bags are removed from Charge No. 2.

Note: In all cases the hermetic cap is removed.

5. Propellant charges for 152 mm. gun-howitzer 1937 model

Serial	Designation of charge	Type of gunpowder	Weight of gunpowder (Kg.)	Composition of charge	Case			Used with shells as below
					Weight (Kg.)	Length (mm.)	Primer type	
1	Full variable charge Zh-545 or ZHN-545	NT-3 16/1 or 15/7 or NF 16/1 or NDT-3 16/1	8.12	Base bag + 8 bags of equal weight	7.65	546	KV-4	OF-540 OF-530 O-530A
2	Reduced variable charge Zh-545U or ZHN-545U	NC 5/1 or NF 5/1 or 4/1 + 7/7OD or WM 017/32 + 7/7 OD (7/7) or 4/1 + 7/7	2.92	Base bag + 6 bags of equal weight	7.65	546	KV-4	OF-540 OF-530 O-530A G-530
3	Special charge Zh-545B	NF 16/1 or NDT-3 16/1 or 18/1 Tr	7.22	A cluster with gunpowder in tubular form	7.65	546	KV-4	BR-540

Note: In all cases the hermetic cap is removed. The Special Charge Zh-545 B is invariable, and as a distinguishing feature it has a black ring on the case.

The approximate weights of the gunpowder in the Full Charge are: in the base bag 5.4 Kg., in each supplementary bag 0.341 Kg.; in the Reduced Charge the base bag weighs 1.3 Kg. and each supplementary bag 0.270 Kg.

The charges are made up as follows:

Full Charge: Only the hermetic cap is removed.
Charge No 1: 2 bags are removed from the Full Charge.
Charge No 2: 3 bags are removed from the Full Charge.
Charge No 3: 4 bags are removed from the Full Charge.
Charge No 4: 6 bags are removed from the Full Charge.
Charge No 5: 8 bags are removed from the Full Charge.
Charge No 6: Only the hermetic cap is removed from the Reduced Charge.
Charge No 7: 1 bag is removed from the Reduced Charge.
Charge No 8: 2 bags are removed from the Reduced Charge.
Charge No 9: 3 bags are removed from the Reduced Charge.
Charge No 10: 4 bags are removed from the Reduced Charge.

Note: Charges No. 1, 2 and 3 may be made up as such at the factory.

6. Packaging of munitions for 152 mm. howitzer and gun-howitzers

Serial	Type of munition	Quantity in box	Dimensions of box (cm.)	Gross weight of box (Kg.?)	Remarks
1	Rounds for 152 mm. howitzer	1	73 x 44 x 26	65	Shells and charges are in the same box.
2	Rounds for 152 mm. gun-howitzer (1966 model)	1	80 x 45 x 27	78	
3	Rounds for 152 mm. gun-howitzer (1937 model)	1	92 x 52 x 25	74	

CHAPTER 11I

MUNITIONS FOR RECOILLESS GUNS

1. MUNITIONS FOR 75mm. RECOILLESS GUNS, 1956 AND 1956-2 MODELS (FIGURES 3-1 AND 3-2)

Both these guns use the same munitions. The rounds for 75 mm. recoilless guns are unitary and are identifiable by the holes in the case

1. Shells for 75 mm. recoilless guns

Serial	Designation of shell	Index	Weight (Kg.)	Length without fuze (mm.)	Charge		Fuze	Colour coding
					Type	Weight (Kg.)		
1	Fragmentation	S-323	6.1	300	Tritol or amatol	0.67	K-1 or K-3	-
2	Shaped charge	BK-323	3.75	310	Tritol mixed with hexogen	0.623	TS-1 or TS-2	-

Note: There also exists a steel fragmentation shell, produced between 1957 and 1959, which has the same details as the fragmentation round index S-323. The S-323 fragmentation round began to be produced in 1960.

2. Rounds used in 75 mm. recoilless guns

Serial	Designation of round	Index	Weight (Kg.)	Length (mm.)	Propellant charge		Case			Colour coding
					Type of gunpowder	Weight (Kg.)	Weight (Kg.)	Length (mm.)	Primer type	
1	Round with S-323 fragmentation shell	-	9	658	9/14	1.5	2.2	407	KV-2	-
2	Round with squash-head shell	-	6.45	717	9/14	1.0	2.2	407	KV-2	-

3. Packaging for munitions for 75 mm. recoilless guns

Serial	Type of munitions	Quantity	Dimensions of box cm.	Weight of box Kg.	Remarks
1	Rounds	2	80 x 33 x 20	33	Boxes with shells produced in 1953 weigh 28.5 Kg.

Note:

1. In the boxes there are, as well as the rounds, the relevant fuzes, placed in hermetically-sealed boxes or screwed into the shell.
2. Each round is placed in a hermetically sealed metal canister.

11. MUNITIONS FOR 82 mm. RECOILLESS GUN MODEL B-10 (FIGURES 3-3 TO 3-5)

Rounds for the 82 mm. recoilless gun have no case. The propellant force is provided by the igniter cartridge and supplementary bag, which are placed into the shell in the factory.

1. Shells for 82 mm. recoilless gun

Serial	Designation of shell	Index	Weight (Kg.)	Length with fuze (mm.)	Charge		Fuze	Remarks
					Type	Weight (Kg.)		
1	Shaped charge	BK-881	3.89	689	Tritol or stronger explosive	0.547	GK-2	
2	Fragmentation	O-881A	3.89	607	Tritol or amatol	0.456	GK-2	
3	Practice	PBK-881	3.89	689	Inert substance	0.547	Dummy	

2. Rounds for 82 mm. recoilless gun

Serial	Designation of round	Index	Weight (Kg.)	Length (mm.)	The propellant charge consists of the igniter cartridge (base) and the supplementary bag				Remarks
					Base Cartridge (igniter)		Supplementary bag		
					Type of gunpowder	Weight (Kg.)	Type of gunpowder	Weight (Kg.)	
1	Shaped charge round	MK-10	4.87	689	KZDP	0.05	NBL-50	0.85	
2	Fragmentation round	MO-10	4.87	607	KZDP	0.05	NBL-50	0.85	
3	Practice round	MPK-10	4.87	689	KZDP	0.05	NBL-50	0.85	

Note:

1. The propellant charges for this gun are invariable.

2. KZDP is a gunpowder with granular smoke generator .

(For clarity items 2 & 3 in Table No. 2. - Rounds for 82 mm. recoilless gun – which are on Page 116 in the original, are shown on Page 115, together with the footnote..

3. Packaging for munitions for 82 mm. recoilless gun

Serial	Type of munitions	Quantity	Dimensions of box (cm.)	Weight of box (Kg.)	Remarks
1	Rounds	4	86 x 54 x 20	46	Each round is packed in a hermetically sealed metal canister
2	GK-2 fuzes	These are fitted to the shells in the factory			

III. MUNITIONS FOR 107 mm. RECOILLESS GUN MODEL B-11 (FIGURES 3-6 TO 3-9)

Rounds for the 107 mm. recoilless gun do not have a case and have a special propellant charge. The propellant charge consists of a retaining device, a primer and a chargebag with gunpowder. The primer is fitted into the tube of the retaining device, with the charge bag surrounding the tube. The connection between the propellant and the shell is made by attachment to the tube of the retaining device. This is inserted into the shell stabiliser and fixed there by a peg with springs.

1. Shells for 107 mm. recoilless gun

Serial	Designation of shell	Index	Weight (Kg.)	Length with fuze (mm.)	Charge		Fuze	Remarks
					Type	Weight (Kg.)		
1	Shaped charge	BK-883	7.52	621	Tritol or stronger explosive	1.08	GK-2	
2	HE-fragmentation	OF-883A	8.51	546	Tritol or amatol	1.06	GK-2	
3	Practice	PBK-883	7.52	621	Inert substance	1.08	Dummy	

2. Propellant charge for rounds used in 107 mm. recoilless gun

Serial	Designation of charge	Composition of charge	Primer		Supplementary chargebag		Remarks
			Type of gunpowder	Weight (Kg.)	Type of gunpowder	Weight (Kg.)	
1	Invariable charge	Primer cartridge + chargebag with gunpowder	DRP (gunpowder with smoke)	0.12	NBL-80	2.45	The length of the propellant charge is approximately 434 mm.

Note: This charge is used for all three types of shell.

3. Packaging for munitions for 107 mm. recoilless gun

Serial	Type of munition	Quantity	Dimensions of box (cm.)	Weight of box (Kg.)	Remarks
1	Rounds with shaped charge shell	2	123 x 42 x 22	52	In each box the shells are complete with the propellant charges
2	Rounds with HE-fragmentation shell	2	123 x 42 x 22	52	In each box the shells are complete with the propellant charges
3	GK-2 fuzes	These are screwed into the shells in the factory			

Note: Every propellant charge is packed in a hermetically sealed canister, separate from the shells.

CHAPTER IV

MUNITIONS FOR GRENADE LAUNCHERS

40 mm. grenade launcher (light) (56 model and 1969 model) (Figures 4-1 to 4-4)

Rounds for the 40 mm. grenade launcher (56 model and 1969 model) consist of a shell (grenade) and the propellant charge, which is special and is attached to the shell before firing.

1. Shells for 40 mm. grenade launcher (1956 and 1969 models)

Serial	Designation of shell (grenade)	Index	Weight (Kg.)	Length (mm.)	Charge		Fuze	Remarks
					Type of charge	Weight (Kg.)		
1	Shaped charge over-calibre grenade for grenade launcher (light) 1956 model	-	1.675	500	Mixture of hexogen and tritol	0.535	Base fuze with inertial activation	The shell has an external diameter of 80 mm.
2	Shaped charge over-calibre grenade for grenade launcher (light) 1969 model	-	1.87	635	Mixture of hexogen and tritol	0.535	Base fuze (secured type) with piezo-electrical activation by impact	The shell has an external diameter of 85 mm.

2. Propellant charges for grenades for 40 mm. grenade launchers

Serial	Charge designator	Type of gunpowder	Weight of gunpowder (Kg.)	Packaging of charge			Remarks
				Type	Length (mm.)	Type of primer	
1	Propellant charge for 40 mm. grenade launcher 1956 model	Gunpowder with smoke	0.170	Cardboard shaped packaging	170	Mechanical primer	
2	Propellant charge for 40 mm. grenade launcher 1969 model	Gunpowder without smoke made from nitro-glycerine in tube or strip form	0.343	Cardboard shaped packaging	293	Mechanical primer	Gunpowder in tube form – 0.219 Kg. gunpowder in strip form 0.124 Kg.

3. Packaging of munitions for 40 mm. grenade launchers

Serial	Type of munition	Quantity	Dimensions of box (cm.)	Weight of box (Kg.)	Remarks
1	Rounds for 40 mm. grenade launcher (light) 1956 model	6	65 x 35 x 23	22	In each box the shells are complete with the propellant charges
2	Rounds for 40 mm. grenade launcher (light) 1969 model	4	81 x 55 x 13	18	In each box the shells are complete with the propellant charges

Note: The fuzes are fitted to the shells in the factory

CHAPTER V.

MORTAR MUNITIONS

I. MUNITIONS FOR 60 mm. MORTAR MODEL 63 (FIGURES 5-1 AND 5-2)

1. Bombs for 60 mm. mortar

Serial	Designation	Index	Weight (Kg.)	Length without fuze (mm.)	Charge		Colour coding	Fuze
					Type of charge	Weight (Kg.)		
1	Fragmentation bomb with 8 fins	-	1.3	200	Tritol or amatol	0.08	None	M-5 M-6
2	Fragmentation bomb with 10 fins	Th-520	1.3	200	Tritol or amatol	0.08	None	M-5 or type of M-6

2. Propellant charges for 60 mm. mortar bombs

Serial	Designation	Components of propellant	Base cartridge		Supplementary charge	
			Type of gunpowder	Weight (Kg.)	Type of gunpowder	Weight (Kg.)
1	Variable charge for eight-finned bombs	Base cartridge + 3 large bags +2 small bags	NBL-10	0.0033	NB in square format	0.008
2	Annular variable charge for ten-finned bombs	Base cartridge + 3 rings	NBL-10 or NGB-10-2.5 X 33	0.0033	NGB-10-23 x 48 or NBK 23/48-10	0.0081

Note:

1. The large bags each have 2 grammes of gunpowder, the small bags 1 gramme each.
2. Each ring has 2.6 grammes of gunpowder.

The charges are made up as follows:

1. For eight-finned bombs with bagged propellant:

Charge No. 0	Base cartridge.
First Charge	Base cartridge + 2 small bags.
Second Charge	Base cartridge + 2 large bags.
Third Charge	Base cartridge + 2 large bags + 2 small bags.
Fourth Charge	Base cartridge + 3 large bags + 2 small bags. (The two small bags are placed together.)

2. For ten-finned bombs with annular propellant:

Charge No. 0	Base cartridge.
Charge No. 1	Base cartridge + 1 annular charge.
Charge No. 2	Base cartridge + 2 annular charges.
Charge No. 3	Base cartridge + 3 annular charges.

3. Packaging of munitions for 60 mm. mortar

Serial	Type of munition	Quantity	Dimensions of box (cm.)	Weight of box (Kg.)	Remarks
1	Bombs complete with propellant and fuzes	10	61 x 28 x 19	21	
2	Bombs complete with propellant and fuzes	12	57 x 27 x 17	24	

Note: Propellants and fuzes are placed in special hermetically sealed boxes within the box containing the bombs.

II. MUNITIONS FOR 82 mm. MORTARS, (1937, 1941, 1943 AND 1953 MODELS)(FIGURES 5-3 TO5-6)

The 1937, 1941, 1943 and 1953 models of the 82 mm. mortar use the same munitions.

1. Bombs for 82 mm. mortar

Serial	Designation	Index	Weight (Kg.)	Length without fuze (mm.)	Charge		Colour coding	Fuze
					Type of charge	Weight (Kg.)		
1	Fragmentation bomb with 10 fins	Th-521 or O-832 D	3.10	279	Tritol or amatol (AT-90, TD-42 etc.)	0.43	-	M-5, type 11 M-6, type 2 K-82
2	Fragmentation bomb with 6 fins	O-832	3.10	279	Tritol or amatol (AT-90, TD-42 etc.)	0.43	-	M-5 M-6
3	Illuminating bomb	S-832 S	3.10	279	Illuminator and one bag of gunpowder with smoke	Illuminator 0.8 Gunpowder with smoke 0.005	Single white ring	T-1

Note: With the S-832S illuminating round the bag containing gunpowder and smoke must be inserted before the fuze is screwed in.

2. Propellant charges for 82 mm. mortar bombs

Serial	Designation	Components of propellant	Base cartridge		Supplementary charge	
			Type of gunpowder	Weight (Kg.)	Type of gunpowder	Weight (Kg.)
1	Variable charge for ten-finned bombs	Base cartridge + 3 annular bags	NBSP-13-47 or NBL-11 or NGB-11	0.008	NGB-14-32 x 65 or NBK 32/65-14	0.047
2	Variable charge for six-finned bombs	Base cartridge + 6 supplementary boat-shaped charges	NBSP-13-47 or BM	0.008	P-45 or VTM	0.0050

Note:

1. Some ten-finned bombs of Soviet manufacture are assembled with only two annular supplementary charges.
2. Six-finned bombs are assembled with only 4 boat-shaped supplementary charges.
3. Each annular bag has approximately 0.013 Kg. of gunpowder, while the boat-shaped charge has 0.007 Kg.
4. Propellants of Chinese manufacture produced up to 1951 (inclusive) showed a failure rate of 1 + 2 % during firing with the First Charge.. To prevent this happening , when firing with the First Charge an additional Pyroxiline ring charge must be placed above the bomb stabiliser in addition to the annular bag. These annular charges are packed separately.

The charges are made up as follows:

1. For ten-finned bombs

First Charge	Base cartridge + 1 annular charge.
Second Charge	Base cartridge + 2 annular charges.
Third Charge	Base cartridge + 3 annular charges.

2. For six-finned bombs:

First Charge	Base cartridge + 1 boat-shaped charge.
Second Charge	Base cartridge + 2 boat-shaped charges.
Third Charge	Base cartridge + 3 boat-shaped charges.
Fourth Charge	Base cartridge + 4 boat-shaped charges.
Fifth Charge	Base cartridge + 5 boat-shaped charges.
Sixth Charge	Base cartridge + 6 boat-shaped charges.

3. Packaging of munitions for 82 mm. mortar

Serial	Type of munition	Quantity	Dimensions of box (cm.)	Weight of box (Kg.)	Remarks
1	Bombs	3	45 x 32 x 15	15	
		6	62 x 46 x 16	29	
		10	54 x 51 x 24	45	
		12	66 x 64 x 24	53	
2	Propellant charges (sets)	320	59 x 54 x 49	68	
		450	59 x 56 x 48	76	
3	Fuzes: M-5 and M-6 T-1	120	52 x 46 x 15	24	
		128	49 x 49 x 23	48	

Note:

1. Boxes containing bombs of Albanian and Chinese manufacture also contain the relevant number of propellant charges. The base cartridges and supplementary charges are put in hermetically sealed tinplate or plastic boxes.
2. In some instances the fuzes are placed in the bomb boxes. The fuzes in these boxes are placed in hermetically sealed metal or plastic boxes.

III. MUNITIONS FOR 107 mm. MORTAR (1938 MODEL) (FIGURES 5-7 AND 5-8)

1. Bombs for 107 mm. mortar

Serial	Designation	Index	Weight (Kg.)	Length without fuze (mm.)	Charge		Colour coding	Fuze
					Type of charge	Weight (Kg.)		
1	Cast-iron HE-fragmentation bomb	ETh-522 OF-841A	8.8	503	Tritol or amatol (AT-90 etc.)	0.9	Single black ring	GVMZ-1 GVMZ-7 K-107
2	Steel HE-fragmentation bomb	Th-522C OF-841T	9.1	503	Tritol or amatol (AT-90 etc.)	1.76	Single black ring	GVMZ-1 GVMZ-7 K-107

Note:

1. With bombs of Chinese manufacture (in white boxes with rope handles) only K-107 fuzes are used. GVMZ-1 and GVMZ-2 fuzes can not be used in these rounds, because the fuze can not be fully screwed into the bomb.
2. Propellants are identical for the 107 mm. and 120 mm. mortars.

2. Packaging of 107 mm. mortar munitions

Serial	Type of munition	Quantity in box	Dimensions of box (cm.)	Weight of box (Kg.)	Remarks
1	Bombs of Albanian and Chinese manufacture	2	75 x 30 x 19	26	The fuzes and propellants are found in the boxes fully assembled
2	Bombs of Soviet manufacture	4	88 x 57 x 18	50	
3	GVMZ-1 fuzes	40	51 x 47 x 14	34	
4	GVMZ-7	40	51 x 47 x 14	34	

IV. MUNITIONS FOR 120 mm. MORTAR (1938, 1945 AND 1955 MODELS) (FIGURES 5-9 TO 5-12)

1. Bombs for 120 mm. mortar

Serial	Designation	Index	Weight (Kg.)	Length without fuze (mm.)	Charge		Colour coding	Fuze
					Type of charge	Weight (Kg.)		
1	Cast-iron HE-fragmentation bomb	ETH-523 OF-843A	15.9	612	Tritol or amatol	1.58	Single black ring on lower section	M-12 GVMZ-7
2	Steel HE-fragmentation bomb	ETH-523C OF-843 OF-843B	15.9 16.0	660	Tritol or amatol	3.0		M-12 GVMZ-7
3	Smoke bomb	D-843A	16.6	612	Smoke generator + one moulded piece of tritol	1.97 + 0.073	Single black ring under centring band	M-12 GVMZ-7
4	Incendiary bomb	Z-843A	17.0	612	Illuminator + one moulded piece of tritol and one moulded piece of igniter.	1.900 + 0.05 + 0.03	Single red ring	M-5 M-6

Note:

1. In smoke bombs of Chinese manufacture the moulded tritol is placed in the cup of the bomb, whereas in those of Chinese manufacture it is separate and during preparation for firing it must be inserted in the bomb before the fuze is screwed in.
2. In incendiary bombs during preparation for firing the moulded igniter is inserted first, then the moulded tritol, and lastly the fuze is screwed in.

2. Propellant charges for 107 and 120 mm. mortar bombs

Serial	Designation	Components of propellant	Base cartridge		Supplementary charge	
			Type of gunpowder	Weight of gunpowder (Kg.)	Type of gunpowder	Weight of gunpowder (Kg.)
1	Variable charge	Base cartridge + 6 annular bags	NBL-33 or NBL-35 or NGB-35-2 x 100	0.03	VTM or 3/1M or VTOD or NBP1 42-20	0.42

The charges are made up as follows:

First Charge	Base cartridge + 1 annular bag.
Second Charge	Base cartridge + 2 annular bags.
Third Charge	Base cartridge + 3 annular bags.
Fourth Charge	Base cartridge + 4 annular bags.
Fifth Charge	Base cartridge + 5 annular bags.
Sixth Charge	Base cartridge + 6 annular bags.

Note:

1. The 107 mm. mortar is fired only with charges up to 4th Charge, therefore 107 mm. bombs are assembled with only 4 supplementary annular bags.
2. 120 mm. rounds of Soviet manufacture are assembled with only 4 supplementary annular charges.
3. Every supplementary charge has approximately 0.07 Kg. of gunpowder.

3. Packaging of 120 mm. mortar munitions

Serial	Type of munition	Quantity in box	Dimensions of box (cm.)	Weight of box (Kg.)	Remarks
1	Bombs	2	96 x 33 x 20	48	
		1	86 x 20 x 20	23	
2	Propellant charges (sets)	60	57 x 56 x 47	59	
		88	62 x 56 x 47	76	
		90	62 x 56 x 47	76	
3	Fuzes	GVMZ-7	40	51 x 47 x 14	34
		M-12	48	51 x 46 x 14	40
		M-5 or M-6	120	52 x 46 x 15	24

Note: In boxes containing bombs of Chinese manufacture the fuzes and propellant charge sets are placed in hermetically sealed boxes.

V. **MUNITIONS FOR 160 mm. MORTAR (1956 MODEL) (FIGURES 5-13 AND 5-14)**

1. Bombs for 160 mm. mortar

Serial	Designation	Index	Weight (Kg.)	Length without fuze (mm.)	Charge		Colour coding	Fuze
					Type of charge	Weight (Kg.)		
1	Steel HE bomb	E-524Ç F-853S	41.14	1056	Tritol or amatol (AT-90 etc.)	9.0	-	M-12 or GVMZ-7
2	Cast-iron HE bomb	E-524g F-853A	41.14	1056	Tritol or amatol (AT-90 etc.)	7.72	Single black ring	M-12 or GVMZ-7
3	Cast-iron HE bomb	F-853	40.87	1072	Tritol or amatol (AT-90 etc.)	7.78	Single black ring	M-12 or GVMZ-7

2. Propellant charges for 160 mm. mortar bombs

Serial	Designation	Components of propellant	Base cartridge		Supplementary charge	
			Type of gunpowder	Weight (Kg.)	Type of gunpowder	Weight (Kg.)
1	Long-range charge	Base cartridge and one special bag	NBL-95 or NGB-95-5 x 250	0.065	NPBL 130-50 or NGB-130-5 x 5	1.6
2	Variable charge	Base cartridge + 3 annular bags	NBL-95 or NGB-95-5 x 250	0.065	NPBL-50-50 or NGB-130 x 5 x 5	0.84

The long-range charge is used as delivered for firing, with no alteration.

The variable charges can be made up as follows:

First Charge Base cartridge + 1 annular bag.
 Second Charge Base cartridge + 2 annular bags.
 Third Charge Base cartridge + 3 annular bags.

Note: Each annular bag has approximately 0.28 Kg. of gunpowder.

3. Packaging of 160 mm. mortar munitions

Serial	Type of munition	Quantity in box	Dimensions of box (cm.)	Weight of box (Kg.)	Remarks	
1	Bombs	1	142 x 26 x 24	57		
2	Long-range propellant charges	28	59 x 56 x 49	72		
3	Variable propellant charges	36	59 x 56 x 49	65		
4	Fuzes	M-12	48	51 x 46 x 14	40	
		GVMZ-7	40	51 x 47 x 14	37	

Note: In boxes containing bombs of Chinese manufacture the fuzes and propellant charge sets are in hermetically sealed boxes.

CHAPTER VI.

BARREL LAUNCHED ROCKETS

(107 mm. rocket launcher (1963 model) 130 mm. rocket launcher SP rocket launcher (1963 model) and ML –13 SP rocket launcher (Figures 6-1 to 6-3)

Rockets consist of an active and a reactive part. The forward piece of the rocket is called active; it is filled with explosive and the fuze is screwed into its nose. The reactive part comprises the rear part of the rocket and is filled with reactive gunpowder.

Rounds for the 107 mm. and 130 mm. (1963 model) rocket launchers have slanting holes in the base of the reactive part. 107 mm. rockets have 6 such holes, whereas the 130 mm. rockets have 8. The gases from the reactive gunpowder, while escaping through these holes, not only provide the propelling force for the projectile, but also force it to spin thus giving it stability in flight.

For rockets used in the ML-13 stabilisation is provided by the stabiliser fins attached to the reactive part.

1. Rockets

Serial	Designation of rocket	Index	Weight (Kg.)	Length without fuze (mm.)	Charge for active part		Charge for reactive part		Fuze
					Type of explosive	Weight (Kg.)	Type of gunpowder	Weight (Kg.)	
1	HE-fragmentation rocket for 107 mm. (1963 model) rocket launcher	ETh-141 or Th-141g	18.36	848	Tritol or amatol	1.255	NGDT-1	3.57	DMK
2	HE-fragmentation rocket for 130 mm. rocket launcher on 1963 model SP launch vehicle	ETh-142 or Eth-142g	32.8	1040	Tritol or amatol	4.5	NGDT-2	6.74	DMK
3	HE-fragmentation rocket for ML-13 SP launcher	OF-941 or OF-942	42.5	1500	Tritol or amatol	4.75	N or NM or NM-2	7	GVMZ-1

Note: The index is not normally shown on rockets of Chinese manufacture.

2. Packaging of rockets

Serial	Type of munition	Quantity in box	Dimensions of box (cm.)	Weight of box (Kg.)	Remarks
1	Rockets for 107 mm. reactive gun (1963 model)	1	90 x 18 x 20	25	Fuzes are also in the boxes
2	Rockets for 130 mm. SP rocket launcher (1963 model)	1	102 x 22 x 25	42	Fuzes are also in the boxes
3	Rockets for ML-13 SP rocket launcher	2	161 x 54 x 28	124	

CHAPTER VII.

SMALL ARMS AMMUNITION: PISTOLS, RIFLES, AUTOMATIC RIFLES, LIGHT AND HEAVY MACHINE GUNS AND AA MACHINE GUNS (FIGURES 7-1 TO 7-20)

Pistol rounds

Serial	Designation of rounds	Round			Bullet		Case		Distinguishing markings	
		Weight (gr.)	Length (mm.)	Weight of gunpowder (gr.)	Weight (gr.)	Length (mm.)	Weight (gr.)	Length (mm.)	On rounds	On boxes
	2	3	4	5	6	7	8	9	10	11
1	7.62 mm. round for pistol and for 1954 model automatic rifle								None	None
2	7.62 round for "Nagant" revolver								"	"
3	9 mm. round for 59 model pistol								"	"

Rounds for 7.62 mm. weapons (56 model): (automatic rifle, rifle, and light machine gun)

Serial	Designation of rounds	Round			Bullet		Case		Distinguishing markings	
		Weight (gr.)	Length (mm.)	Weight of gunpowder (gr.)	Weight (gr.)	Length (mm.)	Weight (gr.)	Length (mm.)	On rounds	On boxes
	2	3	4	5	6	7	8	9	10	11
1	7.62 mm. round with conventional bullet, with or without clip								None	None
2	7.62 mm. round with AP incendiary bullet								Black nose and single red ring or black nose only	Two bands- one black and one red – or single black band
3	7.62 mm. round with tracer bullet								Green nose	Single green band
4	7.62 mm. round with incendiary bullet								Red nose	Single red band
5	7.62 mm. blank round				None	-			-	-

Rounds for 7.62 mm. weapons (53 model): (rifle, and light and heavy machine guns)

(incorporating rows 6 & 7 from Page 142)

Serial	Designation of rounds	Round			Bullet		Case		Distinguishing markings	
		Weight (gr.)	Length (mm.)	Weight of gunpowder (gr.)	Weight (gr.)	Length (mm.)	Weight (gr.)	Length (mm.)	On rounds	On boxes
	2	3	4	5	6	7	8	9	10	11
1	7.62 mm. round with lightweight bullet, with or without clip								None (see note at end)	None (see note at end)
2	7.62 mm. round with heavy bullet								Yellow nose	Single yellow band
3	7.62 mm. round with lightweight bullet with steel core								White nose	Single white band
4	7.62 mm. round with AP-incendiary bullet								Black nose and single red ring	Two bands-one black and one red
5	7.62 mm. round with tracer bullet					-			Green nose	Single green band-
6	7.62 mm. with incendiary tracer bullet								Red nose	Single red band
7	7.62 mm. blank round (simulation)				None				-	-

(Columns 6 & 7 of the Table of rounds for 53 model weapons are attached to the main body of the table on page 141)

12.7 mm. rounds

Serial	Designation of rounds	Round			Bullet		Case		Distinguishing markings	
		Weight (gr.)	Length (mm.)	Weight of gunpowder (gr.)	Weight (gr.)	Length (mm.)	Weight (gr.)	Length (mm.)	On rounds	On boxes
	2	3	4	5	6	7	8	9	10	11
1	12.7 mm. round with AP-incendiary-tracer bullet								Violet nose and single red ring	Two bands: one red, one violet
2	12.7 mm. round with AP-incendiary bullet								Black nose and single red ring or black nose only	Two bands: one black and one red, or single black band only

Row 1 of the table of 14.5 mm. rounds is reproduced with the rest of the table on page 143.

14.5 mm. rounds

Serial	Designation of rounds	Round			Bullet		Case		Distinguishing markings	
		Weight (gr.)	Length (mm.)	Weight of gunpowder (gr.)	Weight (gr.)	Length (mm.)	Weight (gr.)	Length (mm.)	On rounds	On boxes
	2	3	4	5	6	7	8	9	10	11
1	14.5 mm. round with AP-incendiary bullet								Black nose and red ring or black nose only	Two bands-black and red – or single black band
2	14.5 mm. round with AP-incendiary bullet with special core								Black nose and remainder of bullet red	Two black rings
3	14.5 mm. round with AP-incendiary-tracer bullet								Violet nose and single red band or violet nose only	One violet band and one red or single violet band only
4	14.5 mm. round with incendiary bullet								Red nose	Single red band

Note:

1. 7.62 rounds for model 53 weapons with lightweight bullet and of Chinese manufacture may have a steel (bimetallic) case or a brass case. The distinguishing marks showing the metal used are on the outside of the boxes as follows:

- (*) *Brass case*
- (*) *Steel case*

Rounds with a brass case produced in 1952 and 1953 when fired from the tank-mounted heavy machine gun have proved to be defective. Separation of bullet and case occurs, causing blockage of the gun.

Heavy machine guns mounted on tanks or carried by infantry units must therefore be supplied with rounds with steel (bimetallic) cases or with rounds with brass cases manufactured after 1953. If during training brass-case rounds manufactured in 1952-3 are used the gas regulator of the above-mentioned machine gun must be placed in position 1 or 2

Company machine guns (1958 model), light machine guns (1953 model) and tank-mounted light machine guns do not suffer jamming during firing with the above-mentioned rounds.

CHAPTER VIII.

HAND GRENADES (FIGURES 8-1 TO 8-11)

(As in the previous chapters the headings have been removed from the continuous table, and the table split up. This results in variable column widths as between tables. The separate tables are reproduced without page breaks, although each table starts on the same page as in the original.)

1. ANTI-PERSONNEL HAND GRENADES

Serial	Designation	Index	Weight of grenade (Kg.)	Weight of explosive (Kg.)	Fragment dispersal radius (metres)	Penetration capability (mm.)	Method and activation time of detonator	Remarks
	2	3	4	5	6	7	8	9
1	Assault Hand Grenade model 42	RG-42	0.4	0.1	15-20	-	Time-delay (2.8-3.2 seconds after launching)	The NUGD unified detonator is used for the Assault Grenade model 42 and the Defensive Grenade model 1
2	Assault Hand Grenade model 59	-	0.3	0.1	15-20	-	"	
3	Defensive Hand Grenade model 1	F-1	0.7	0,05	200	-	"	
4	Assault Hand Grenade with wooden stick	-	0.3	0.05	15-20	-	Time activation 2.5-3 seconds after removal of the ring	
5	Defensive Hand Grenade with wooden stick	-	0.7	0.1	200	-	Time activation 2.5-3 seconds after removal of the ring	

2. ANTI-TANK HAND GRENADES

Serial	Designation	Index	Weight of grenade (Kg.)	Weight of explosive (Kg.)	Fragment dispersal radius (metres)	Penetration capability (mm.)	Method and activation time of detonator	Remarks
	2	3	4	5	6	7	8	9
1	Anti-tank Hand Grenade model 43	RPG-43	1.2	0.34	15-20	75	Immediate activation on impact	Before use the detonator must be fully screwed into the holder in the handle
2	Anti-tank Hand Grenade model 6	RPG-6	1.1	0.34	15-20	75	""	The detonator is in a cylindrical recess in the body
3	Anti-tank Hand Grenade model 3	RKG-3	1.1	0.34	15-20	75	""	""

CHAPTER IX.

SIGNAL AND ILLUMINATING ROUNDS (FIGURES 9-1 TO 9/7)

Serial	Designation	Weight of round (gr.)	Weight of gunpowder (gr.)	Length of round (mm.)	Height to which element rises (metres)	Duration of signal (seconds)	Strength of illumination (candlepower)	Radius of illumination (metres)	Visibility of signal (Km.)	Distinguishing marks
	2	3	4	5	6	7	8	9	10	11
1	26 mm. night signalling round (red)	50-52	2.5	75	90	6.5	10,000	-	7	Red cap with one circular projection
2	26 mm. night signalling round (green)	50-52	2.5	75	90	6.5	10,000	-	7	Green cap with two circular projections
3	26 mm. night signalling round (yellow)	54-56	2.5	75	90	6.5	10,000	-	7	Yellow cap with one longitudinal projection
4	26 mm. day signalling round (red)	47-50	3.5	100	65	7-15	10,000	-	2	Square red cap with one red ring on case
5	26 mm. day signalling round (green)	47-50	3.5	100	65	7-15	10,000	-	2	Square green cap with one green ring on case
6	26 mm. day signalling round (blue)	47-50	3.5	100	65	7-15	10,000	-	2	Square blue cap with one blue ring on case
7	26 mm. illuminating round	56-58	3	75	120	6.5	70,000	100	- By day 1-2 By night 7	White cap with three circular projections
8	40 mm. illuminating rocket	390-400	3 +20	260	400	25	100,000	250	By day 3-4 Km., by night 15 Km.	White cap with one semi-circular projection

Page blank; see previous page.

CHAPTER X.

CHARACTERISTICS AND USE OF SHELL FUZES

(FIGURES 10-1 TO 10-49)

(As in previous chapters the headings have been removed from within the continuous table, and the table split up. This results in variable column widths as between tables. The separate tables are reproduced without page breaks, although each table starts on the same page as in the original. Column 4 has been split so as to show weapons and types of munitions in tabular form)

1. Fuzes for mortar bombs

Serial	Make or designation of fuze 2	Characteristics 3	Use 4	
			Shell	Type
			1	M-5
2	GVMZ-1	Nose-mounted-fuze, unsecured type, activated on impact, with two settings: A) Immediate acting (arrow on setting screw pointing to "O") B) Delayed action (arrow on setting screw pointing to "Z") Before firing it is essential to remove the securing cap and to use the key to make the appropriate setting.	107-120 mm. mortars ML-13 SP rocket launcher:	HE-fragmentation (Soviet manufacture) HE-fragmentation
3	GVMZ-7	Nose-mounted-fuze, semi-secured type, activated on impact, with two settings: A) Immediate acting (arrow on setting screw pointing to "O") B) Delayed action (arrow on setting screw pointing to "Z") Before firing it is essential to remove both caps, the hermetic cap and the securing cap and to select the appropriate setting.	120 mm. mortar 160 mm. mortar also: 107 mm. mortar	HE-fragmentation HE HE-fragmentation (Soviet manufacture)
4	M-12	Nose-mounted-fuze, semi-secured type, activated on impact, with two settings: A) Immediate acting (arrow on setting screw pointing to "O") B) Delayed action (arrow on setting screw pointing to "Z")	120 mm. mortar	HE-fragmentation Smoke

		Before firing it is essential to remove the securing cap and to select the appropriate setting.	160 mm. mortar	HE
5	M-6 or Type-1A	Nose-mounted fuze, secured type, immediate acting and with inertial activation. Before firing the securing cap must be removed.	60 mm. mortar 82 mm. mortar 120 mm. mortar	Fragmentation Fragmentation Incendiary
6	K-107	Nose-mounted fuze, unsecured type, immediate acting. It is essential to remove the securing cap before firing.	107 mm. mortar	HE-fragmentation (Chinese manufacture) (two shells per box)
7	T-1	Nose-mounted flash-producing fuze, with distance and impact activation. Before firing the hermetic cap must be removed, and the fuze setting selected, aligning the required setting-mark with the red line on the body of the fuze. Impact activation occurs if the fuze does not detonate in flight. There are 125 setting-marks on the lower annulus of the fuze, each one corresponding to 0.385 seconds. A setting of less than 10 is not permitted..	82 mm. mortar	Illuminating

2. Fuzes for ground artillery shells

Serial	Make or designation of fuze	Characteristics	Use	
			4	
			Shell	Type
1	KTM-1	Nose-mounted-fuze, semi-secured type, with delayed activation.	45 mm gun) 76 mm. regimental gun) 76 mm. field gun)	HE and HE-fragmentation
			Use of this fuze in guns mounted on tanks and SPG is forbidden. Also in 45 mm. guns when positioned among other artillery pieces.	
2	KTM-1-U	The design and characteristics of this fuze are identical with those of the KTM-1. The only change is the resistance of the springs.	45 mm. field and tank guns) 76 mm. field and tank guns) 85 mm. field and tank guns)	Fragmentation and HE-fragmentation
3	KTMZ-1U	Nose-mounted-fuze, semi-secured type, with delayed activation. The only difference from the KTM-1-U is that it contains gunpowder retardant	45 mm. field and tank guns) 76 mm. field and tank guns) 85 mm. field and tank guns)	Fragmentation and HE-fragmentation
4	KTM-2	Identical with KTM-1, differing only in the dimensions of the screw thread	122 mm. howitzer	Smoke
5	MGN	Nose-mounted fuze, secured type, immediate-acting	76 mm. tank and SP guns) 85 mm. tank and SP guns)	Fragmentation and HE-fragmentation
6	RGM	Nose-mounted fuze, secured type, activated on impact, with three settings: A) Immediate acting (without cap and with arrow pointing to "O") B) Inertial action (with cap, and arrow pointing to "O") C) Delayed action (with cap and with arrow pointing to "Z")	100 mm. gun) 122 mm. gun) 130 mm .gun) 152 mm. gun-howitzer)	Fragmentation and HE-fragmentation
7	RGM-2 or RGM-3, 4 5	The characteristics of these fuzes are identical with those of the RGM. There are some design differences from the RGM fuze.	122 mm. howitzer) 152 mm. howitzer) 152 mm. gun-howitzer)	Fragmentation and HE-fragmentation
			122 mm. howitzer	Smoke (cast-iron body)

Serial	Make or designation of fuze	Characteristics	Use	
			4	
			Shell	Type
8	RGM-6	Characteristics and design are approximately the same as the RGM-2 fuze. The only difference is the strength of the springs.	100 mm. gun (model 44)) 130 mm. coastal artillery) gun (separate loading)) 152 mm. gun-howitzer)	Fragmentation and HE-fragmentation
9	V-429	Identical to the RGM-6.	100 mm. gun (model 44)) 130 mm. coastal artillery) gun (separate loading)) 152 mm. gun-howitzer) (1966 model))	Fragmentation and HE-fragmentation
10	D-1-U	Secured type fuze with distance and impact activation, with two settings: A) Distance activation (in-flight detonation.) B) Immediate activation (impact.) Before firing the hermetic cap is removed from the fuze and the appropriate setting selected. The distance setting is obtained by aligning the required (distance) marking on the lower annulus with the red line on the body of the fuze. The setting for immediate (impact) activation is obtained by aligning the letters "UD" on the lower annulus with the red line on the body of the fuze.	122 mm. howitzer) 152 mm. gun-howitzers) (for destructive fire)	Fragmentation and HE-fragmentation
11	BM	Nose-mounted fuze, unsecured type, immediate-acting. No preparation required before firing.	76 mm. regimental gun (model 43)	Shaped charge
12	V-229	Identical to BM fuze.	122 mm. howitzer	Shaped charge

Serial	Make or designation of fuze	Characteristics	Use	
			4	
			Shell	Type
13	GKV	Nose-mounted fuze, secured type, immediate acting.	122 mm. howitzer	Shaped charge
14	VGU-1	Secured type fuze with distance and impact activation, with three settings: A) Immediate activation (without cap, setting screw lever at "O".) B) Inertial activation (with cap, arrow on setting screw at "O".) C) Delayed activation (with cap, arrow on setting screw at "Z")	130 mm. coastal artillery gun (mechanical extraction)	HE-fragmentation
15	T-6	Nose-mounted flash-producing fuze, with distance and impact activation. Before firing the hermetic cap must be removed, and the fuze setting selected, aligning the required setting-mark with the red line on the body of the fuze. Impact activation occurs if the fuze does not detonate in flight.	122 mm. howitzer	Illuminating (index S.462)
16	T-7	The same as the T-6 fuze, except that the scale on the lower annulus has 165 divisions, each with a value of 0.5 seconds.	122 mm. howitzer	Illuminating (index S.463)
17	VM-16	Mechanical fuze, secured type, distance operating with clockwork, setting obtained by aligning marker required with red line on body of fuze..	100 mm. coastal artillery gun (mechanical extraction)	Fragmentation airburst
18	VM-60	The same as the VM-16, the only difference by the length of activity (activation?) time.	130 mm. coastal artillery gun (mechanical extraction)	Fragmentation airburst
19	MD-5	Base-mounted fuze, unsecured type, impact-activate (inertial). The fuze is screwed into the base of the shell in the factory.	45 mm .anti-tank gun	AP
			Use of this fuze is prohibited in 76 mm. and 85 mm. calibre shells.	
20	MD-7	Delayed activation impact fuze, unsecured type. The fuze is screwed into the base of the shell in the factory.	76-152 mm. calibre weapons	AP
21	MD-8	Identical as for the MD-7 fuze. except for the pitch and diameter of the thread.	76-152 mm. calibre weapons	AP

Serial	Make or designation of fuze	Characteristics	Use	
			4	
			Shell	Type
22	2 MR	Base-mounted fuze, secured type, impact activated, with two settings. A – Inertial activation (arrow on lever at "O") B- Delayed activation (arrow on lever at "Z".) The fuze is screwed into the base of the shell in the factory	130 mm. coastal artillery gun (separate loading)	Semi-AP
23	ZMR	Base-mounted fuze, secured type, impact activated with delay. The fuze is screwed into the shell in the factory	100 mm. coastal artillery gun with mechanical extraction	HE
24	V-350	Identical to the 2MR fuze. This fuze may or may not be screwed into the shell in the factory.	130 mm. coastal artillery gun with mechanical extraction	Semi-AP
25	KTD	Base-mounted fuze, secured type, impact activated with two settings A – Inertial activation (arrow on setting screw at "O") B- Delayed activation (arrow on setting screw at "Z".) The fuze is screwed into the base of the shell in the factory. It leaves the factory, and should at all times be stored, with the setting screw in the transit position, (PK.) Before firing the setting screw should be turned to the selected setting.	152 mm. howitzer) 152 mm. gun-howitzer)	Concrete-piercing

3. Fuzes for AA artillery and aircraft cannon shells

Serial	Make or designation of fuze	Characteristics	Use	
			4	
			Shell	Type
1	K-20 and K-20M	Nose-mounted fuze, unsecured type, immediate activation. No preparation required before firing	25 mm. AA gun) 23 mm. aircraft) cannon)	Fragmentation
2	A-23	Unsecured type, immediate activation. No preparation required before firing	23 mm. aircraft cannon	Fragmentation- incendiary-tracer

Serial	Make or designation of fuze 2	Characteristics 3	Use 4	
			Shell	Type
3	B-23	Identical to A-23	25 mm. AA gun) 23 mm. naval gun)	Fragmentation- incendiary
4	A-30	Nose-mounted fuze, unsecured type, delayed activation. No preparation required before firing	30 mm. aircraft cannon	Fragmentation- incendiary
5	30-1	Unsecured type with inertial activation. Fuze has self-destruct mechanism.	30 mm. aircraft cannon	Fragmentation- incendiary
7	A-37	Nose-mounted fuze, secured type, with immediate activation and self-destruct mechanism. No preparation required before firing.	37 mm. aircraft cannon	Fragmentation- incendiary-tracer
8	MG-37	Nose-mounted fuze, secured type, with immediate activation. May or may not have securing cap. Where present this must be removed without fail before firing. Fitted with self-destruct mechanism.	37 mm. AA gun	Fragmentation- tracer
9	MG-57	The same as the MG-37, but with larger dimensions.	57 mm. AA gun	Fragmentation- tracer
10	MD-10	Base-mounted fuze, unsecured type, impact activation with delay The fuze is screwed into the base of the shell in the factory.	57 mm. AA gun	AP-tracer
11	T-5	Nose-mounted fuze, secured type, distance activation, with timing by gunpowder rings. Before firing the hermetic cap is removed and the setting selected by aligning the required setting mark with the red line on the body of the fuze.	85 mm. AA gun	Fragmentation- airburst
12	VM-30	Nose-mounted mechanical fuze, secured type, distance activated, with timing by clockwork.	85 mm. AA gun) 100 mm. AA gun)	Fragmentation- airburst

4. Fuzes for shells for recoilless guns, reactive weapons and grenade launchers

Serial	Make or designation of fuze 2	Characteristics 3	Use 4	
			Shell	Type
			1	GK-2
2	TS-1 and TS-2	Identical with GK-2	75 mm. recoilless guns	Shaped charge
3	K-3-75 K-1	Nose-mounted mechanical fuze, unsecured type, impact activation, with two settings: A Immediate activation (without cap.) B Inertial activation (with cap.)	75 mm. recoilless guns	Fragmentation
4	DMK	Nose-mounted fuze, semi-secured type, impact activated with three settings: A – Immediate activation (without cap, arrow on setting screw pointing to "O.") B - Inertial activation (with cap, arrow on setting screw pointing to "O.") C - Delayed activation (with cap, arrow on setting screw pointing to "Z.")	107 mm. rocket launcher) (1963 model)) 130 mm .rocket launcher) (1963 model)) Note: shells for the ML-13 SP launcher use GVMZ-1 fuzes (see entry 2 of this table.)	HE-fragmentation
5	Fuze for shells for 40 mm. Grenade launcher (light) 56 model	Base-mounted fuze, unsecured type, inertial activation.	40 mm. Grenade launcher (light) 56 model	Shaped charge
6	Fuze for shells for 40 mm. Grenade launcher (light) 1969 model	Base-mounted fuze, secured type, with piezo-electric activation on impact.	40 mm. Grenade launcher (light) 1969 model	Shaped charge

Page blank

PART II

DRAWINGS OF MUNITIONS FOR ARTILLERY WEAPONS WITH RIFLED BARRELS

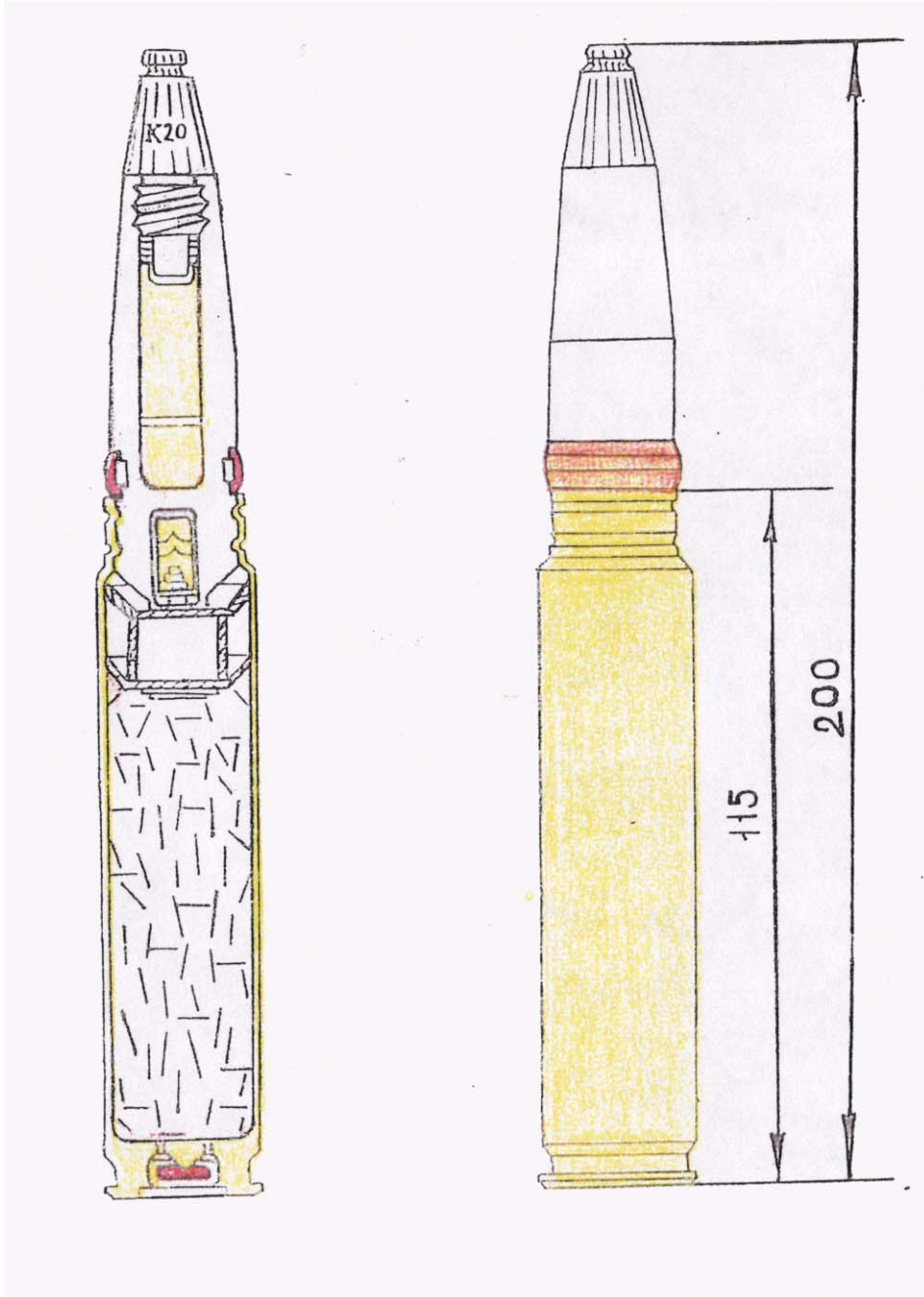

Figure 2-1 Round for 23 mm. aircraft cannon with fragmentation-incendiary-tracer shell.

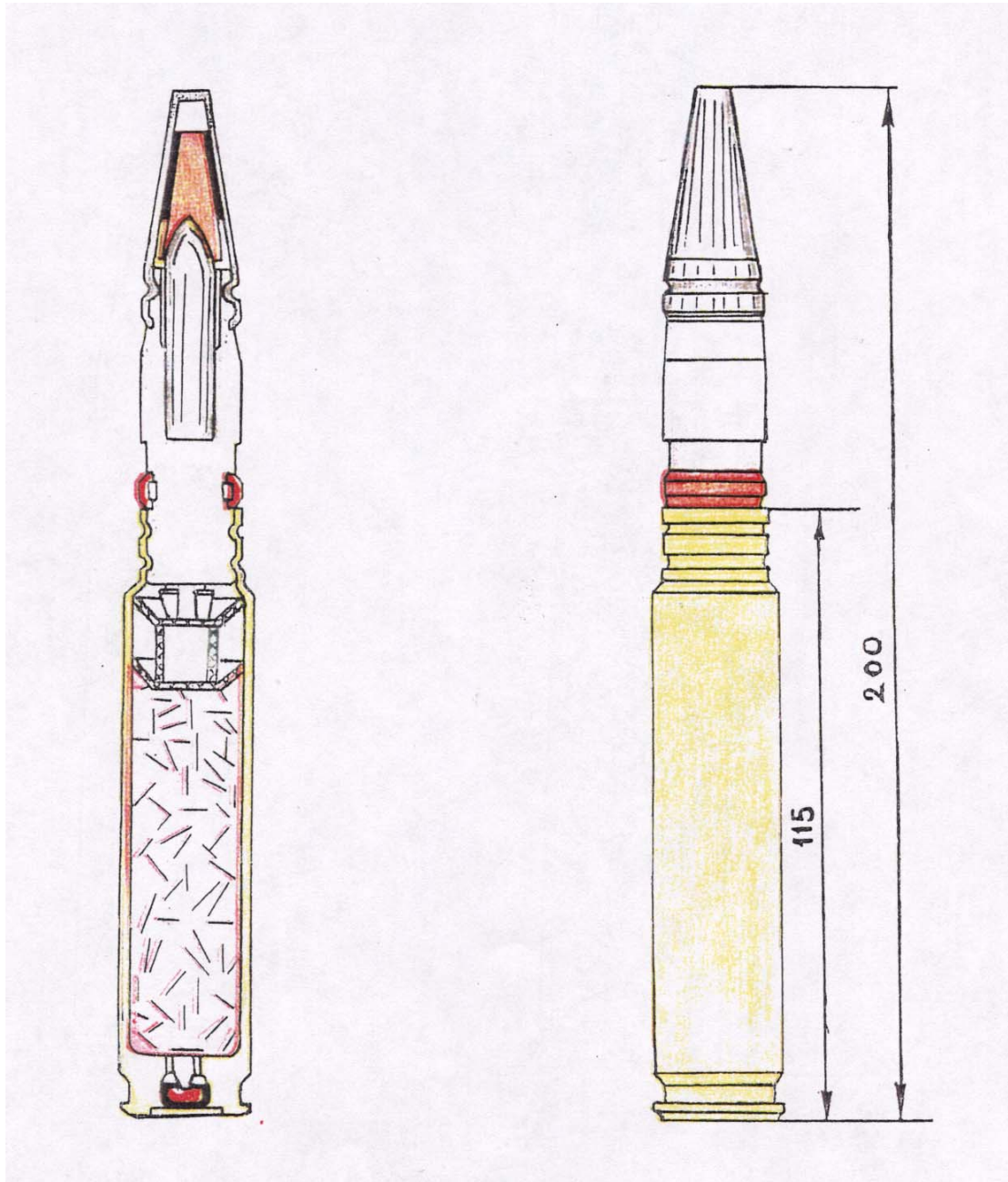

Figure 2-2 Round for 23 mm. aircraft cannon with AP incendiary shell.

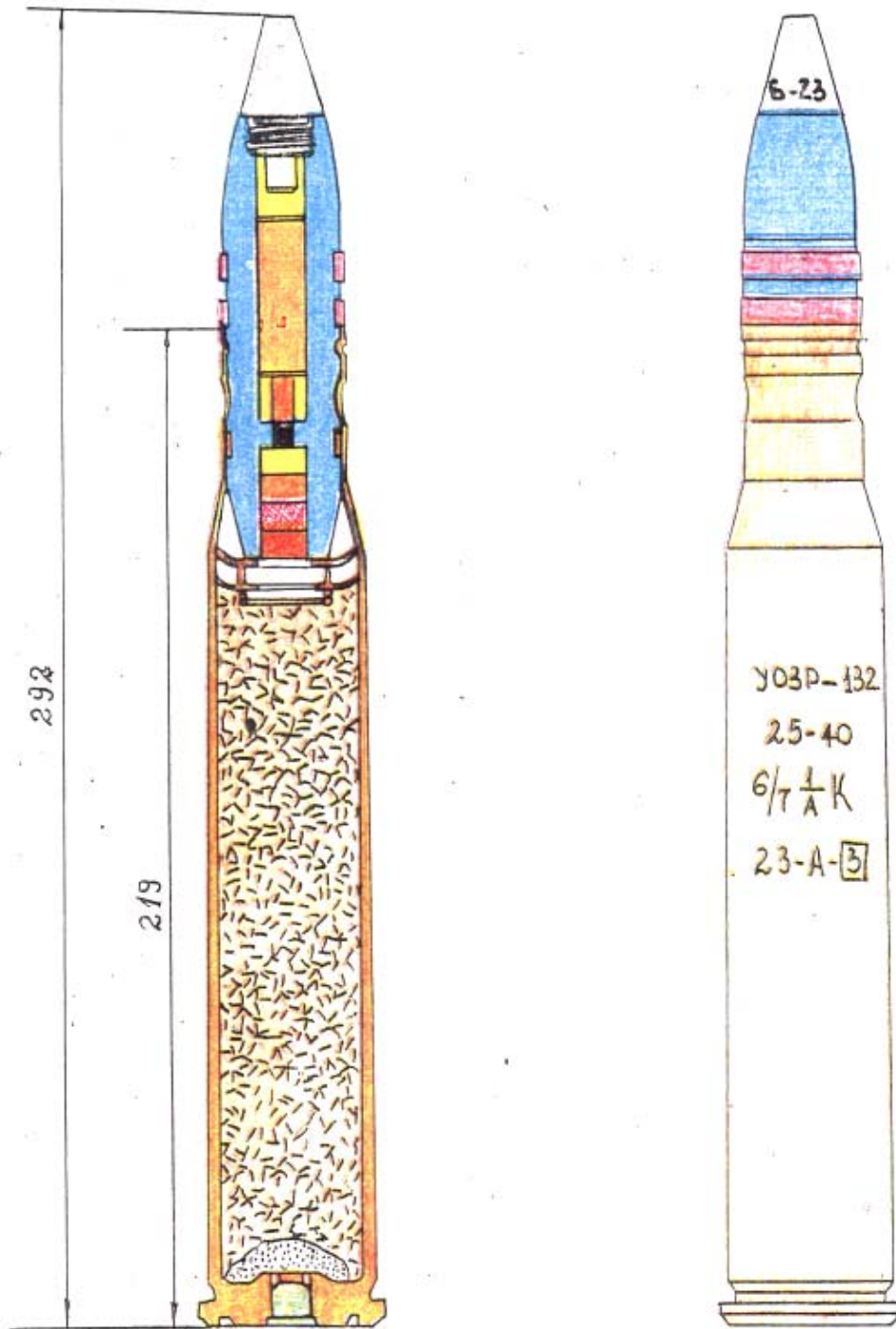

Figure 2-3 Round with fragmentation tracer shell for 25 mm. AA gun.

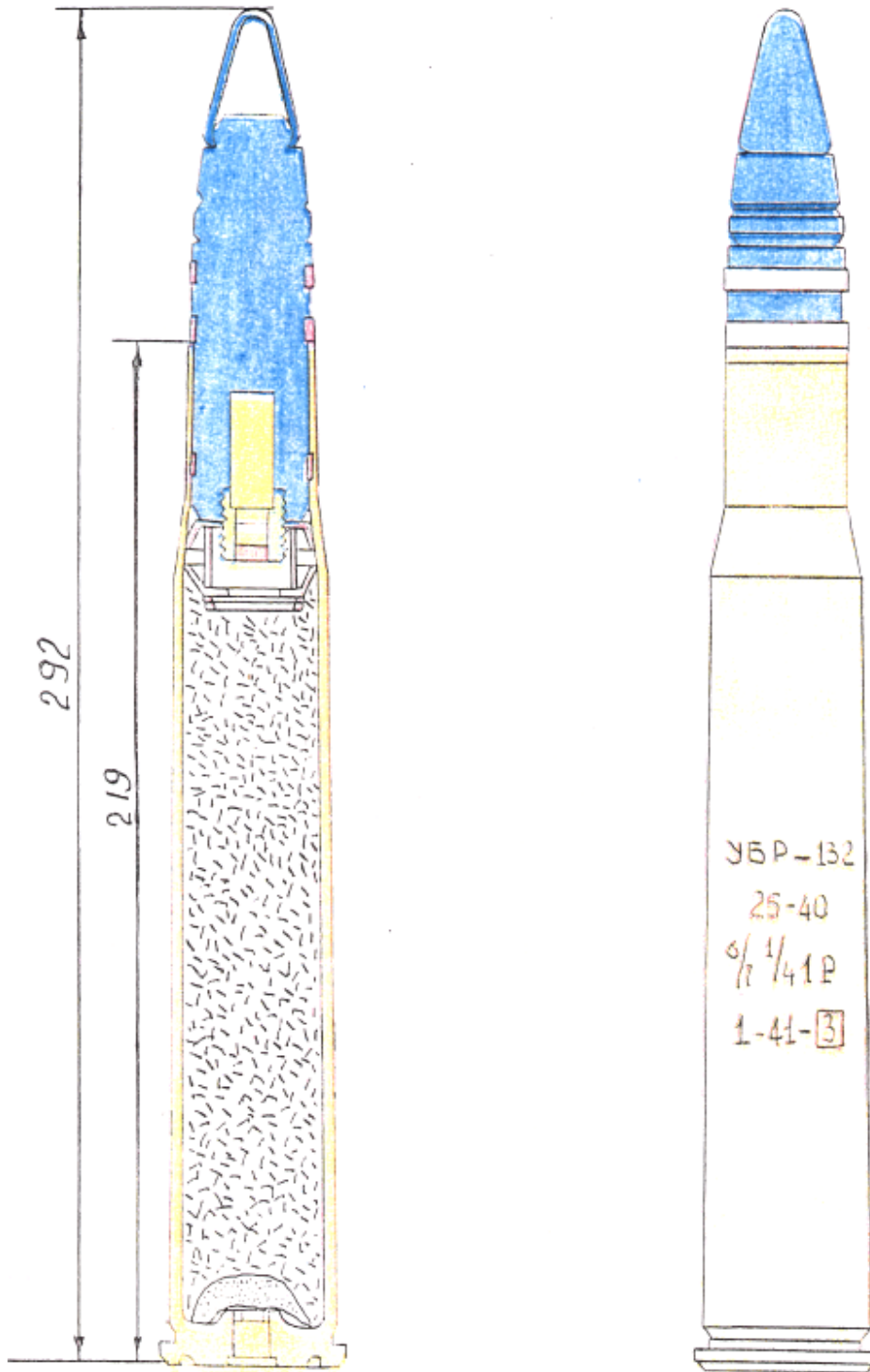

Figure 2-4 Round with AP tracer shell for 25 mm. AA gun.

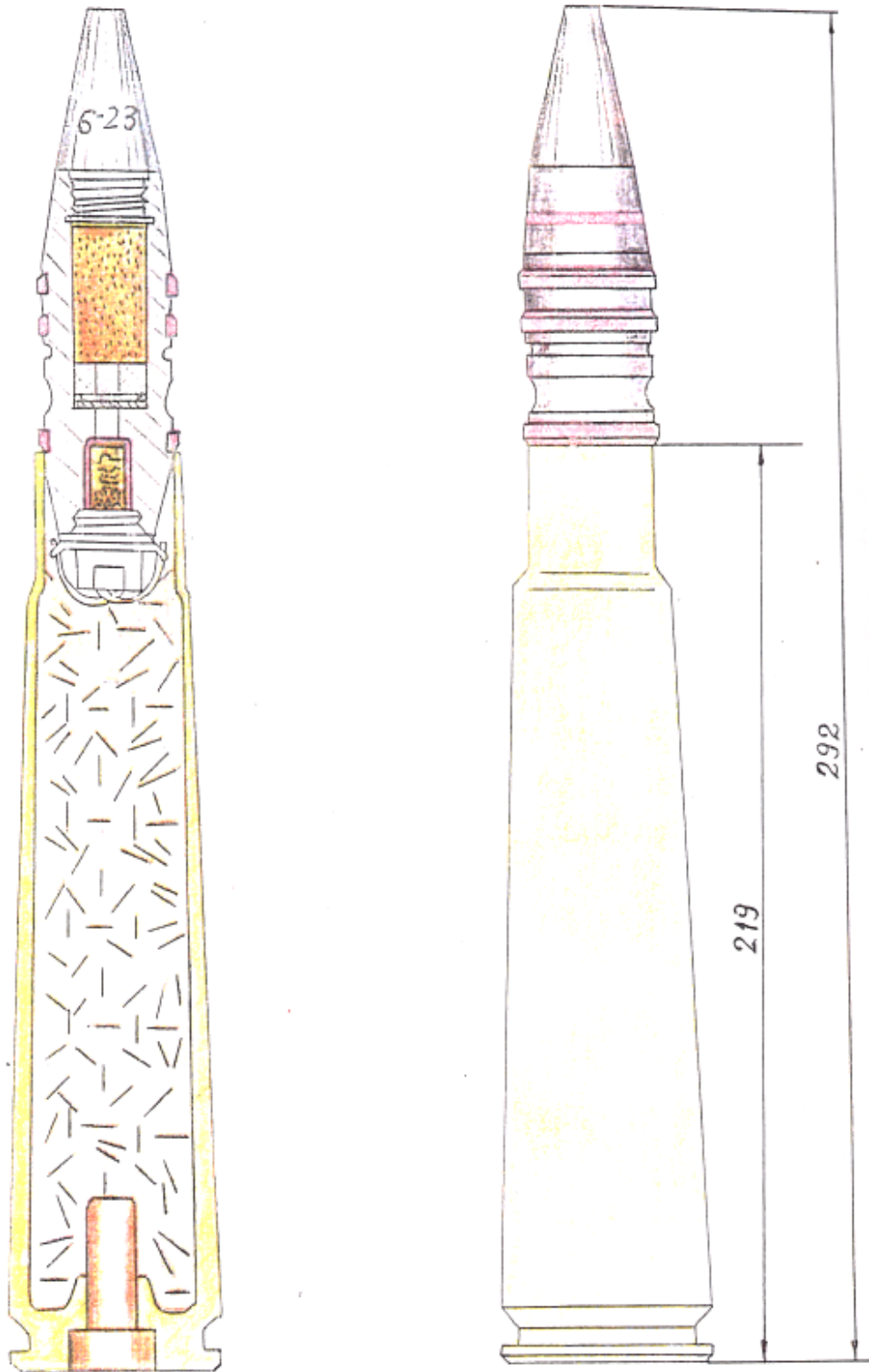

Figure 2-5 Round for 25 mm. naval gun with fragmentation incendiary tracer shell.

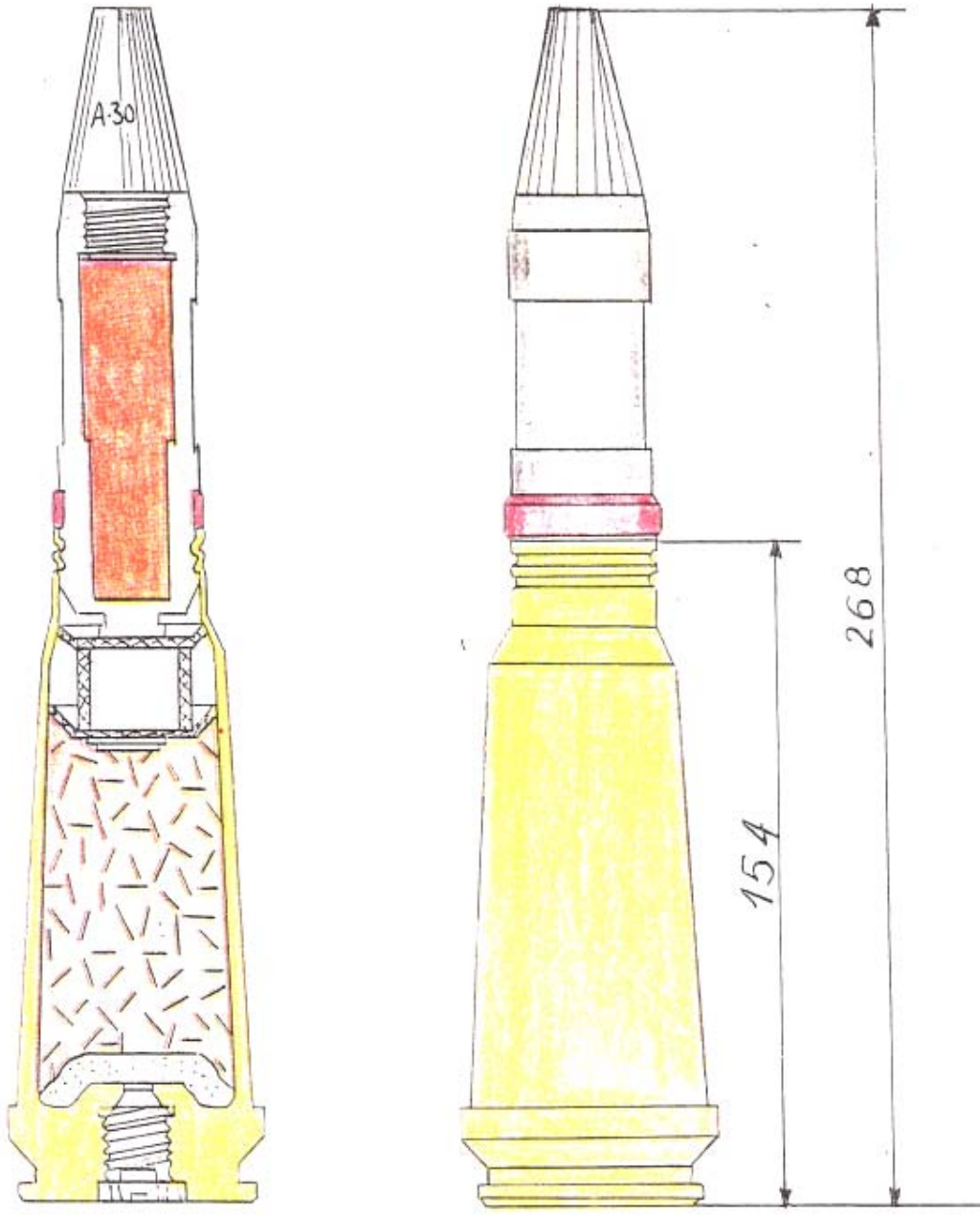

Figure 2-6 Round for 30 mm. aircraft cannon with fragmentation incendiary shell.

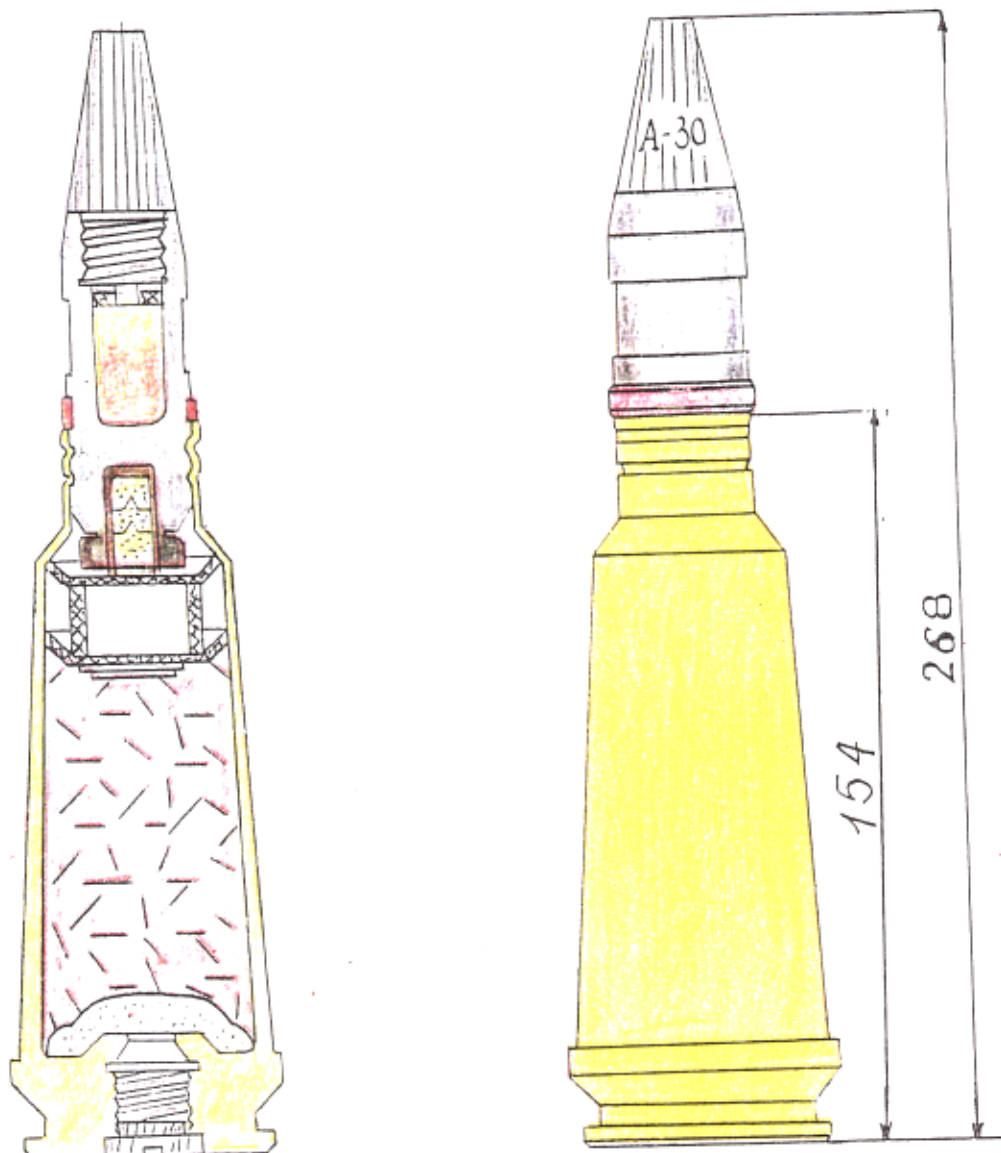

Figure 2-7 Round for 30 mm. aircraft cannon with fragmentation incendiary tracer shell.

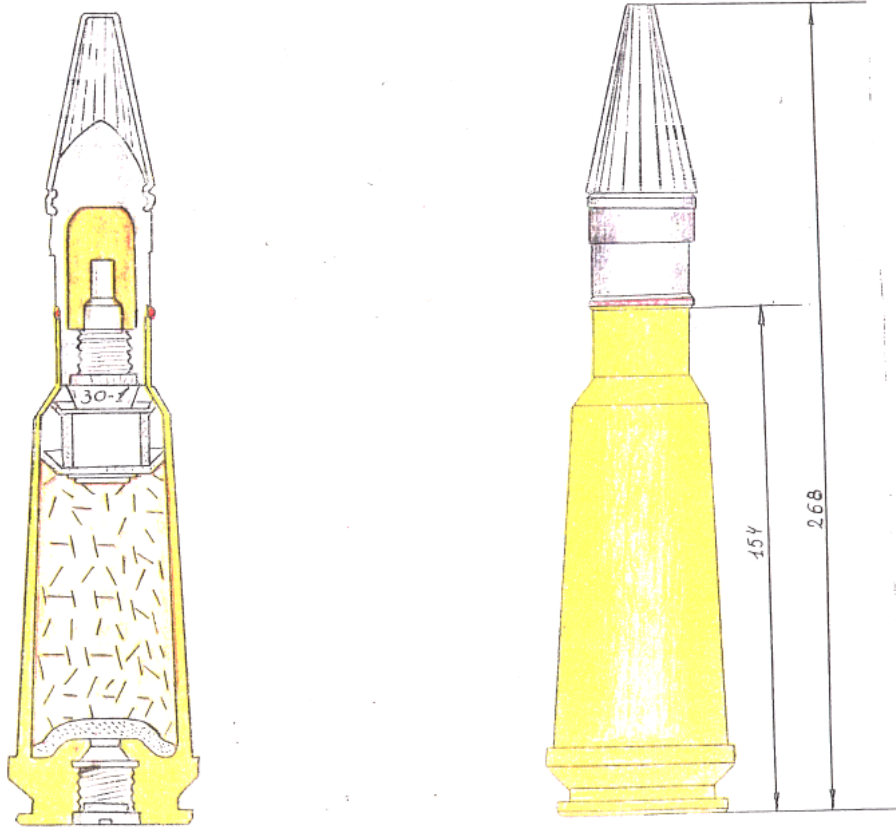

Figure 2-8 Round for 30 mm. aircraft cannon with AP tracer shell.

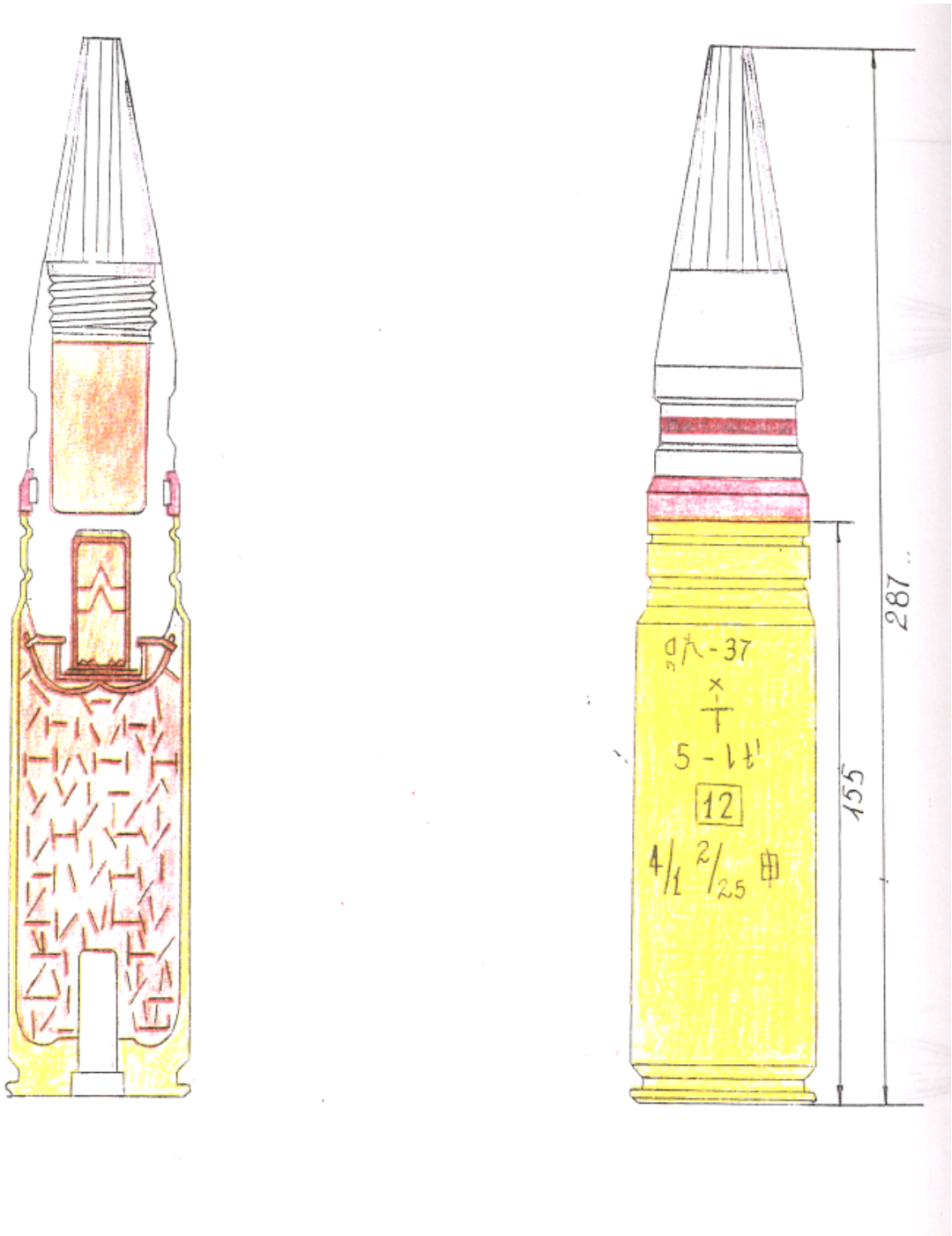

Figure 2-9 Round for 37 mm. aircraft cannon with fragmentation incendiary tracer shell.

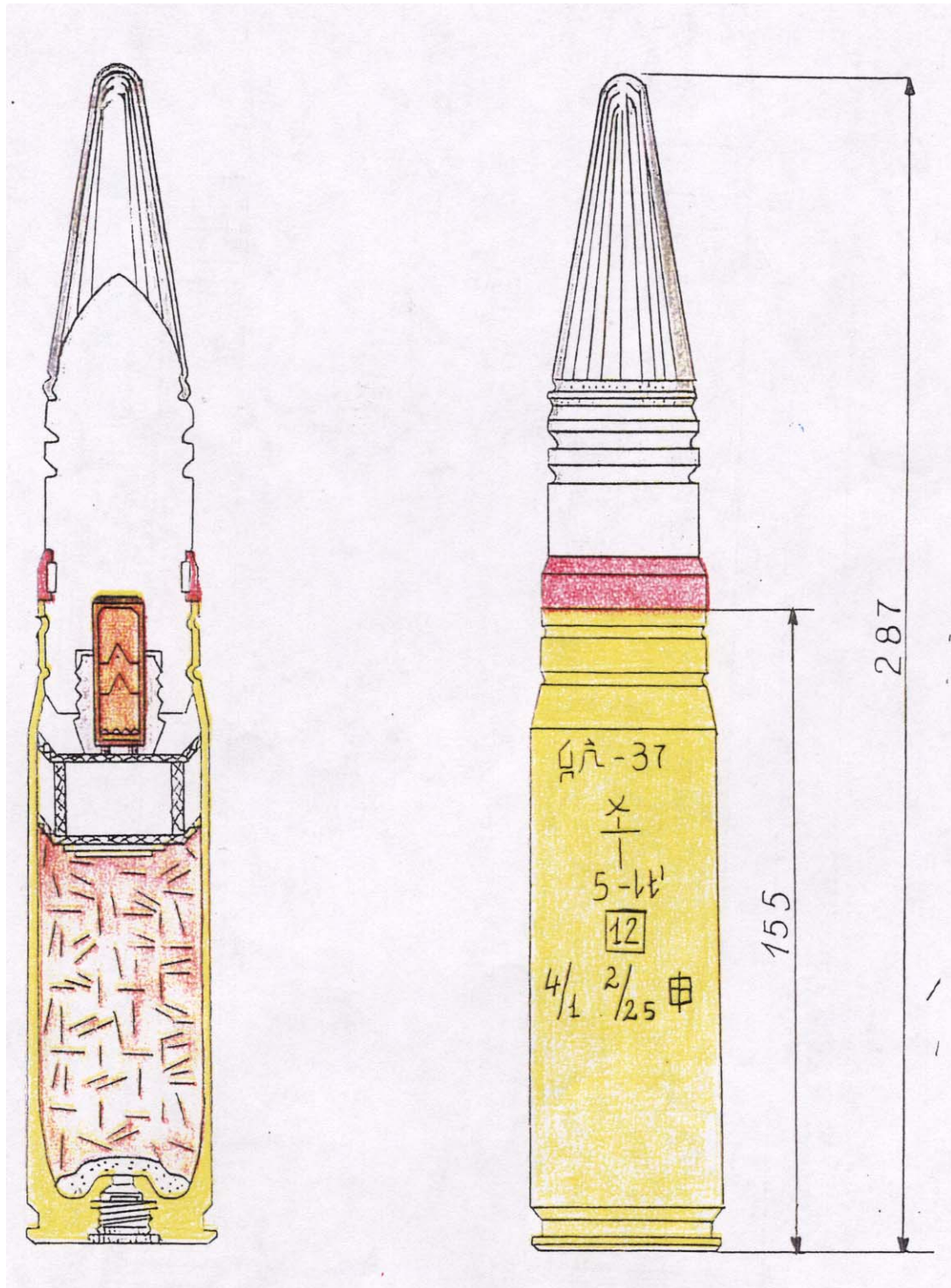

Figure 2-10 Round for 37 mm. aircraft cannon with AP incendiary tracer shell.

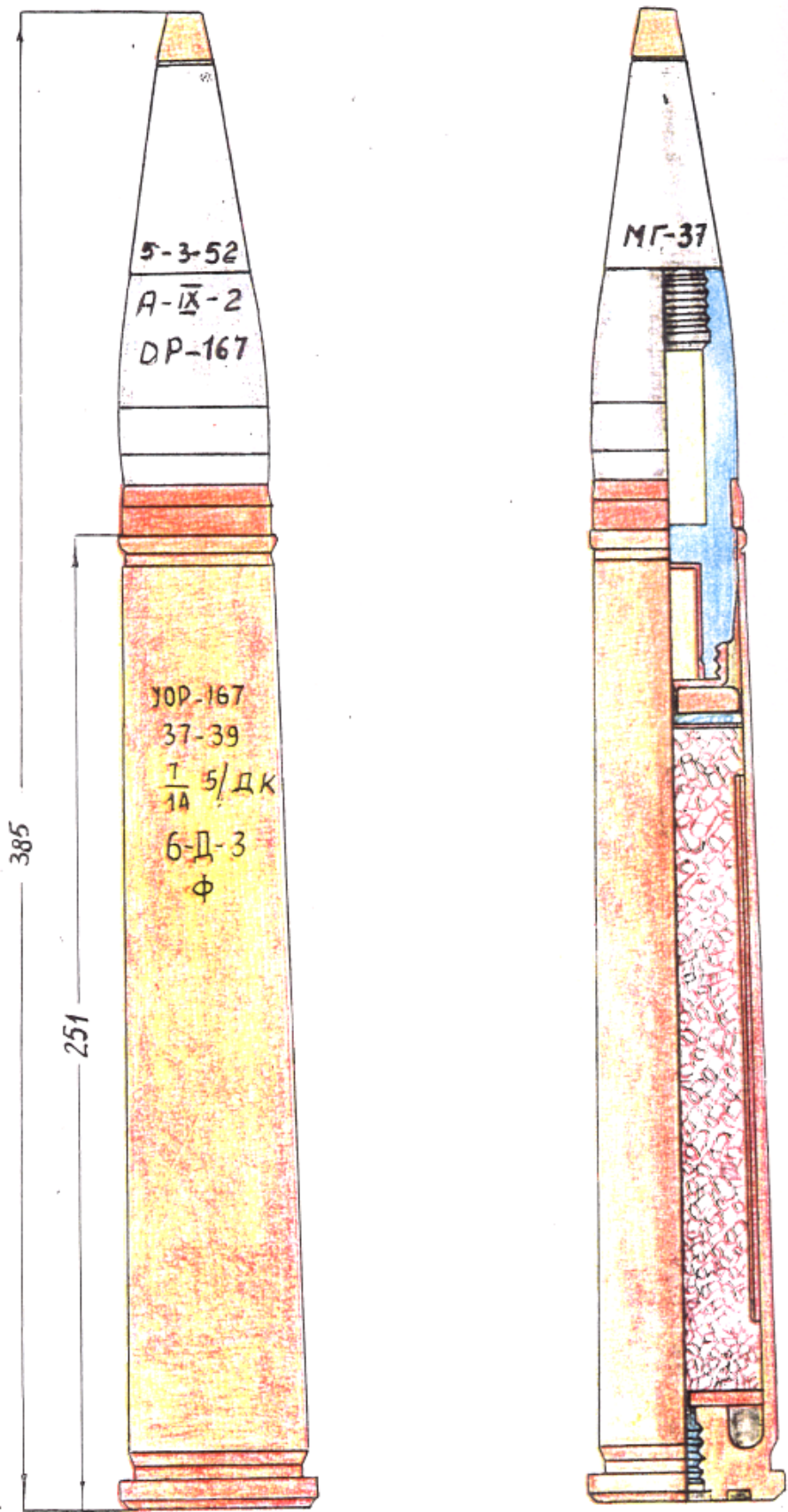

Figure 2-11 Round for 37 mm. AA gun with fragmentation tracer shell.

Figure 2-12 is likewise omitted, although is referred to on Page 70. Figure 2-12 should presumably show the round with solid AP tracer shell (index BR-167) for the 37 mm. gun family (excluding aircraft cannon.)

Figure 2-12 See above

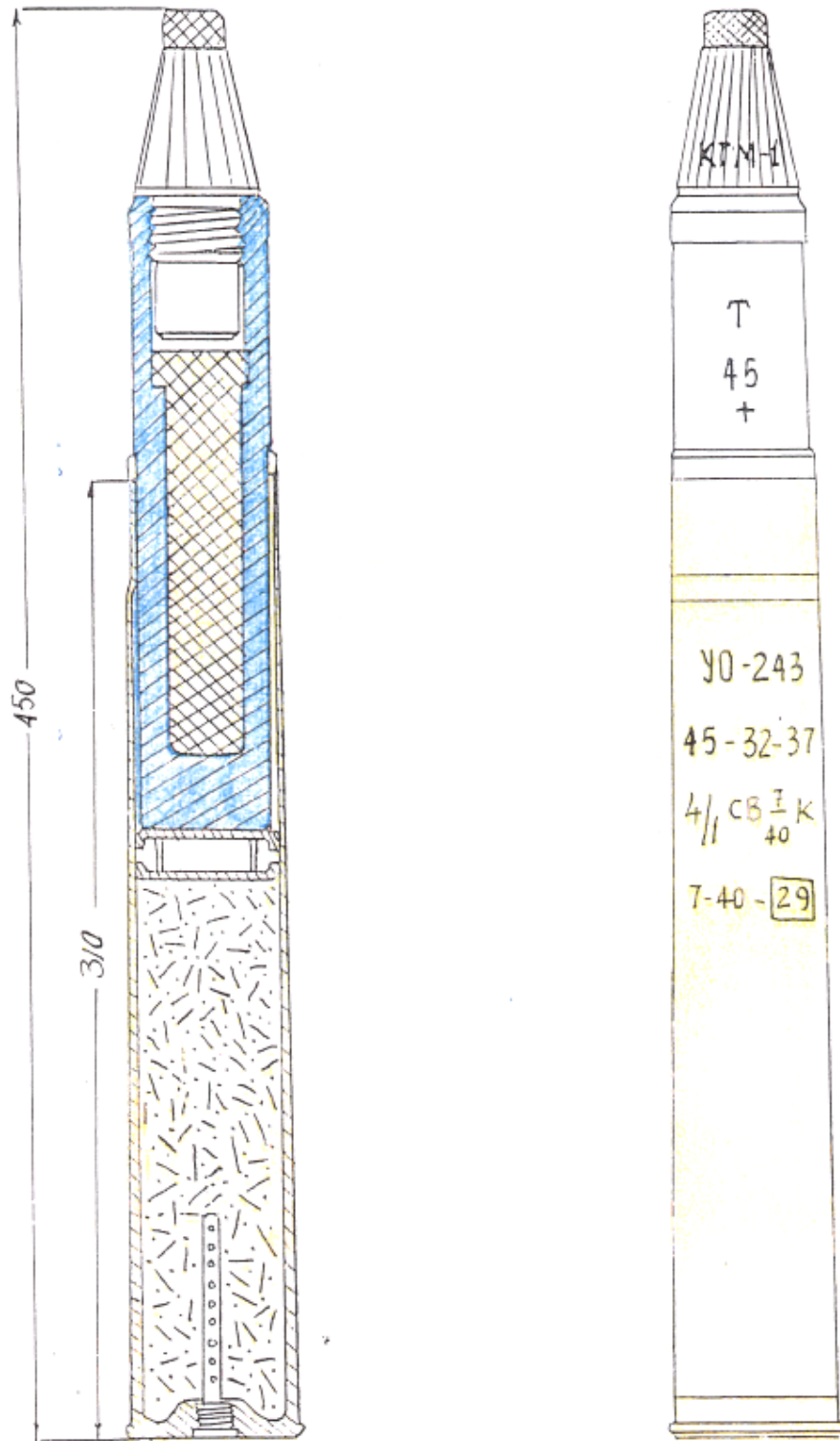

Figure 2-13 45 mm. round with short range fragmentation shell.

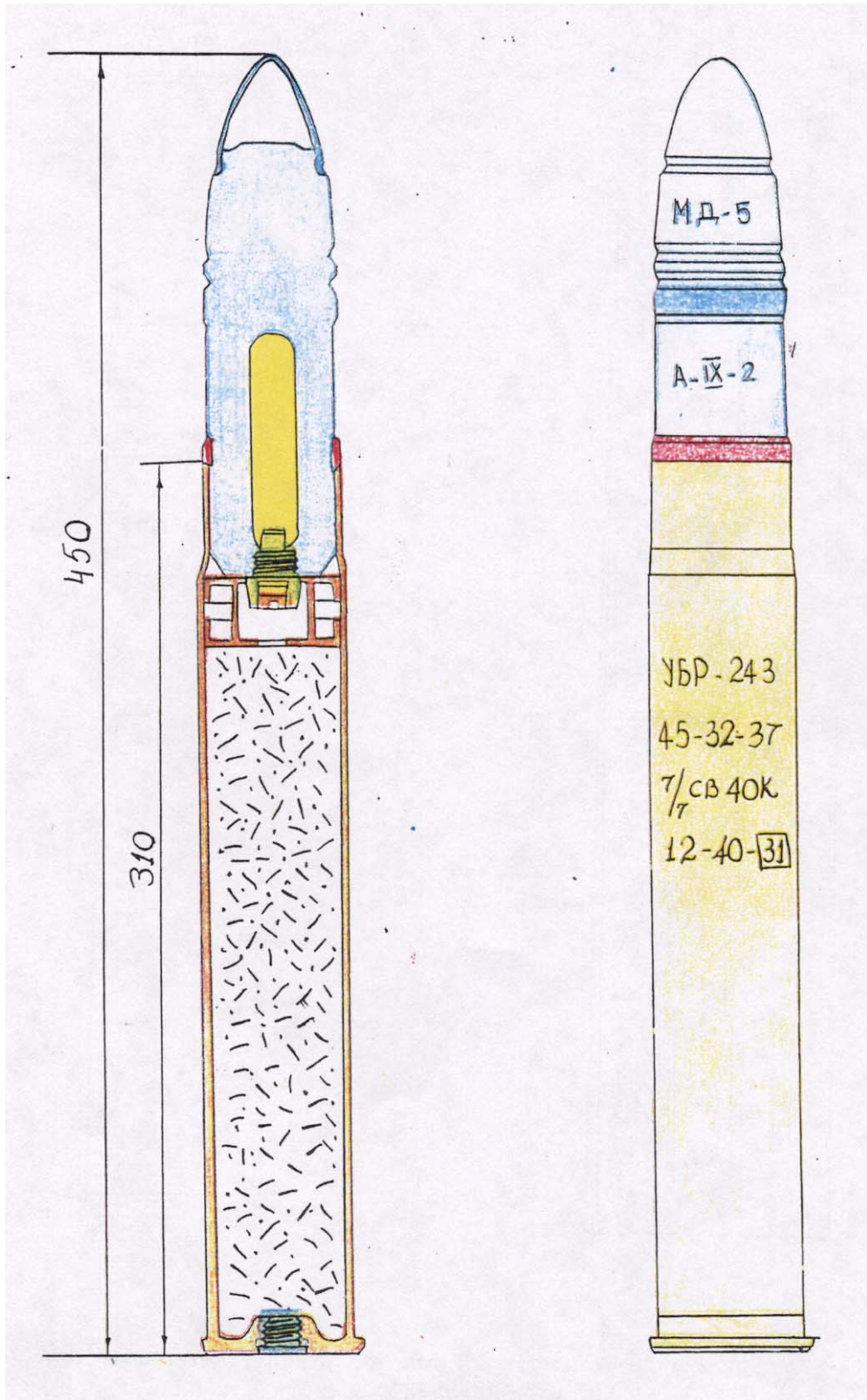

Figure 2-14 45 mm. round with AP tracer shell.

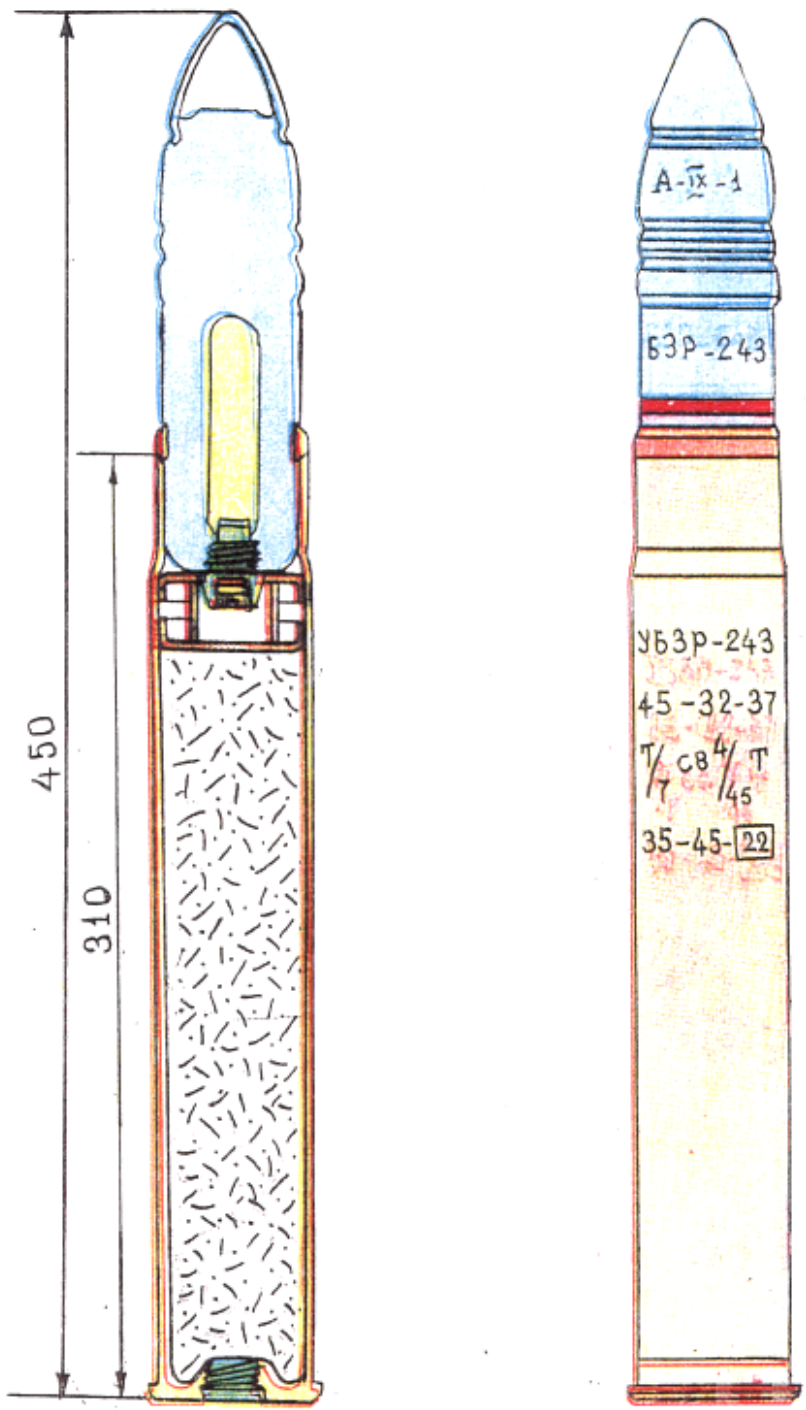

Figure 2-15 45 mm. round with AP incendiary tracer shell.

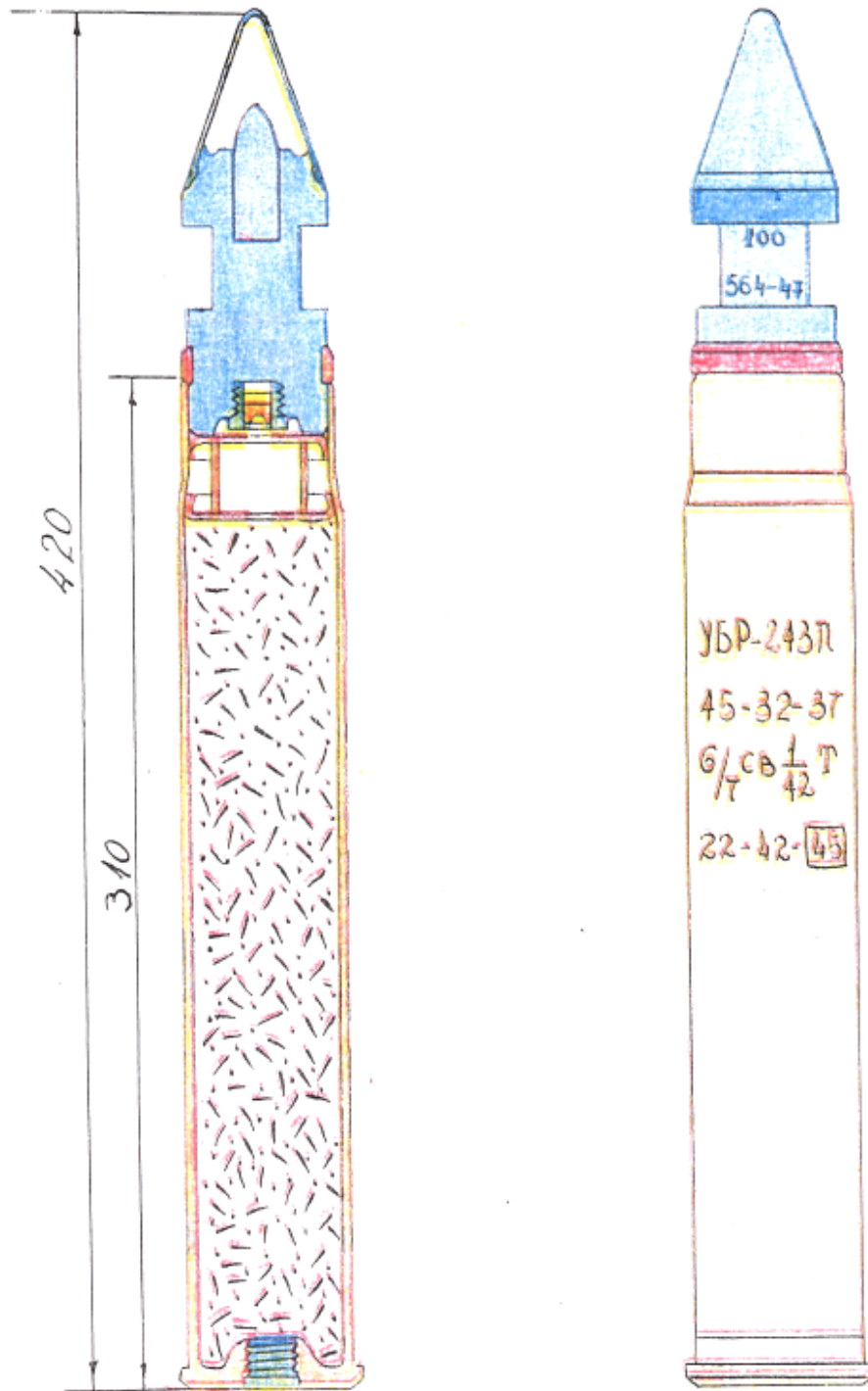

Figure 2-16 45 mm. round with AP sub-calibre shell.

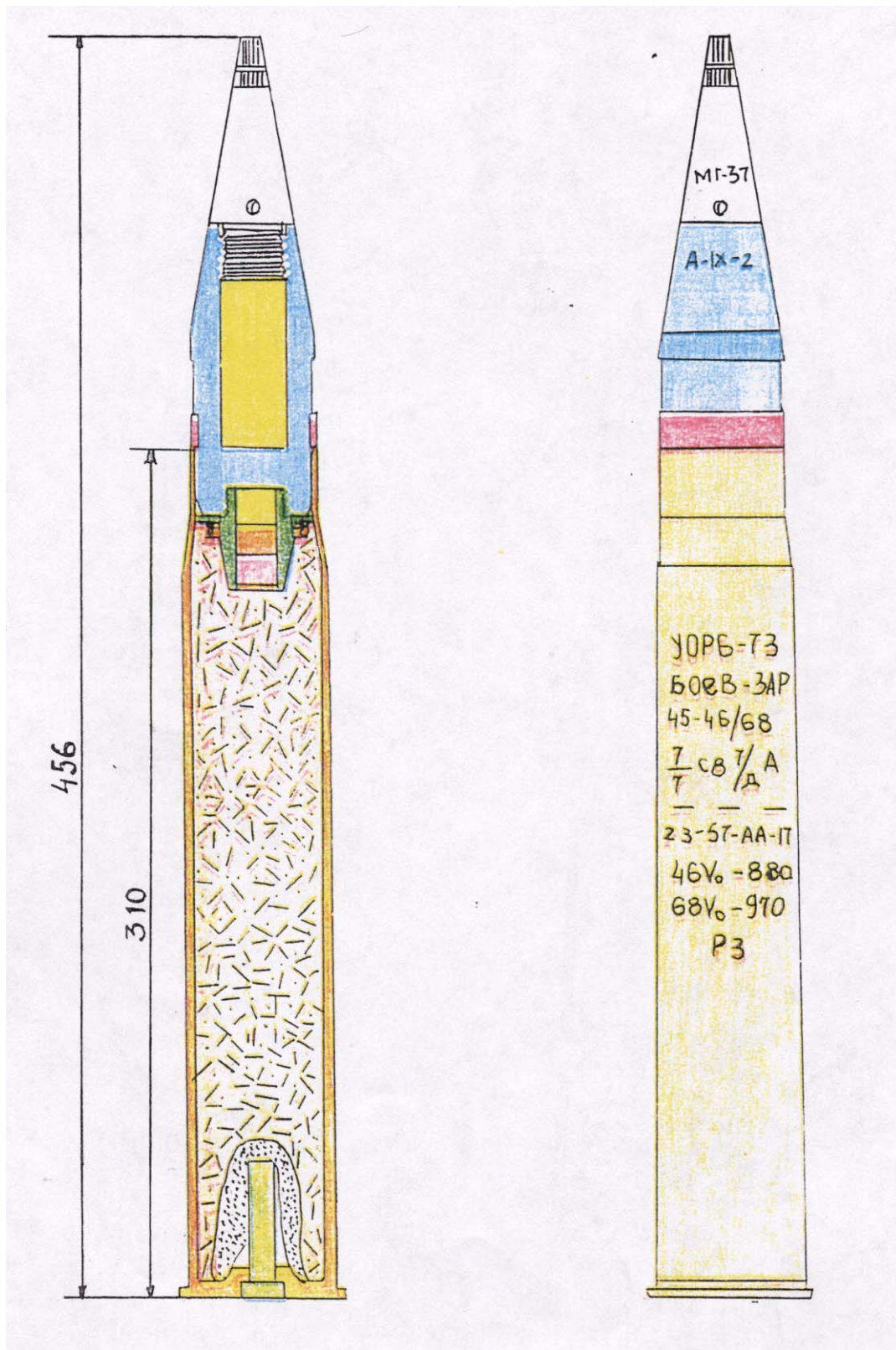

Figure 2-17 45 mm. round with AA fragmentation shell for naval gun.

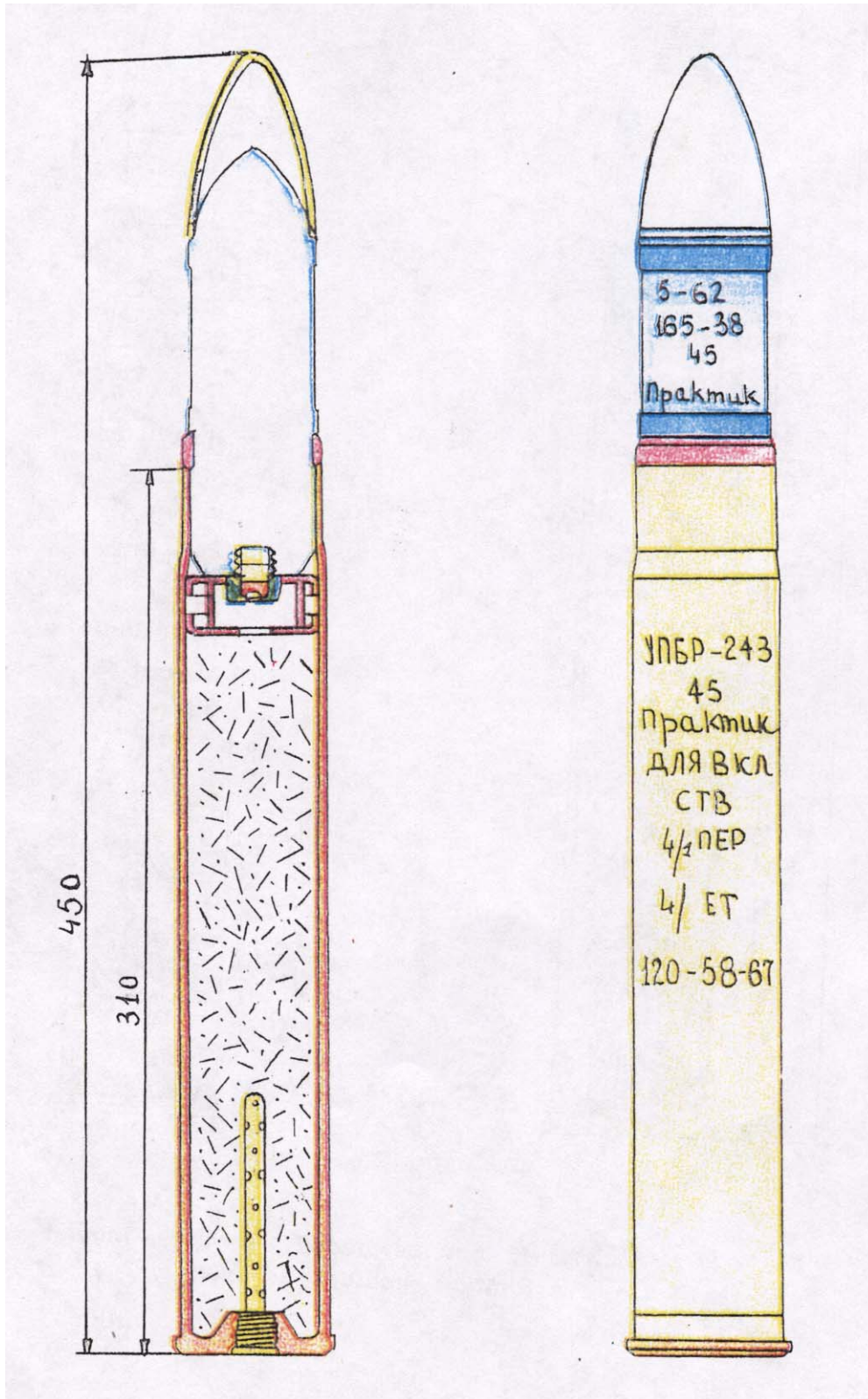

Figure 2-18 45 mm. round with practice tracer shell

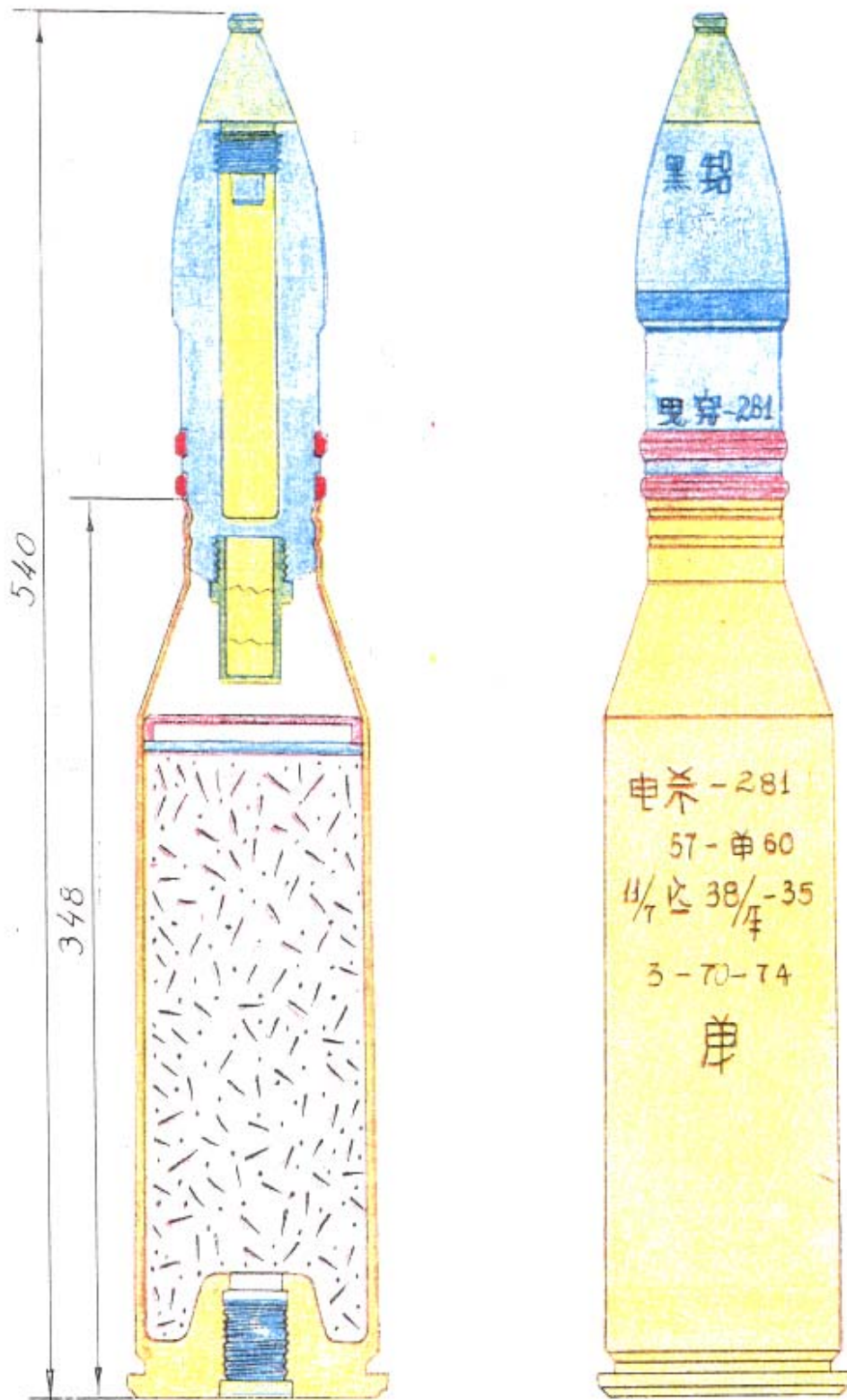

Figure 2-19 Round for 57 mm. AA gun with fragmentation tracer shell.

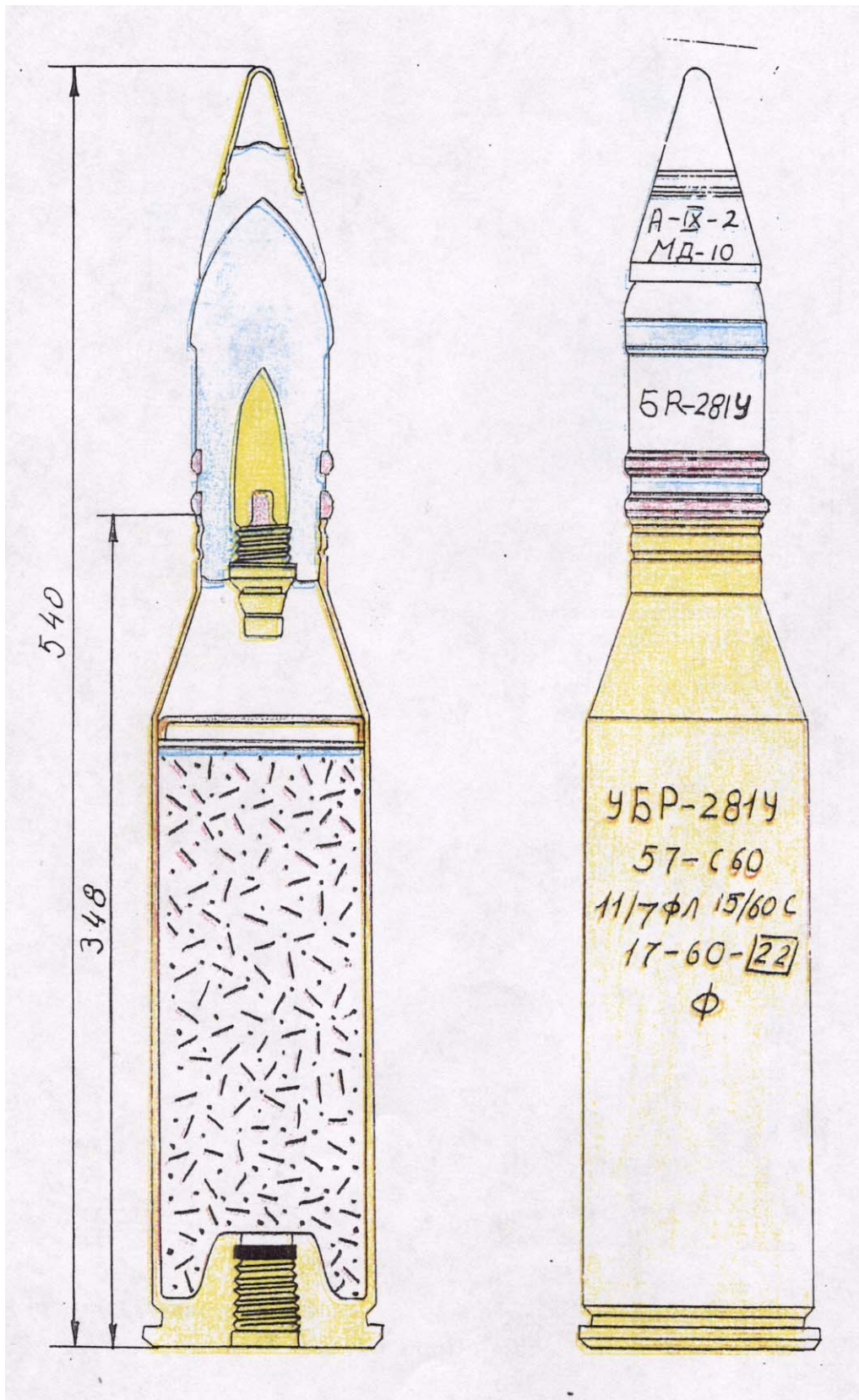

Figure 2-20 Round for 57 mm. AA gun with AP tracer shell.

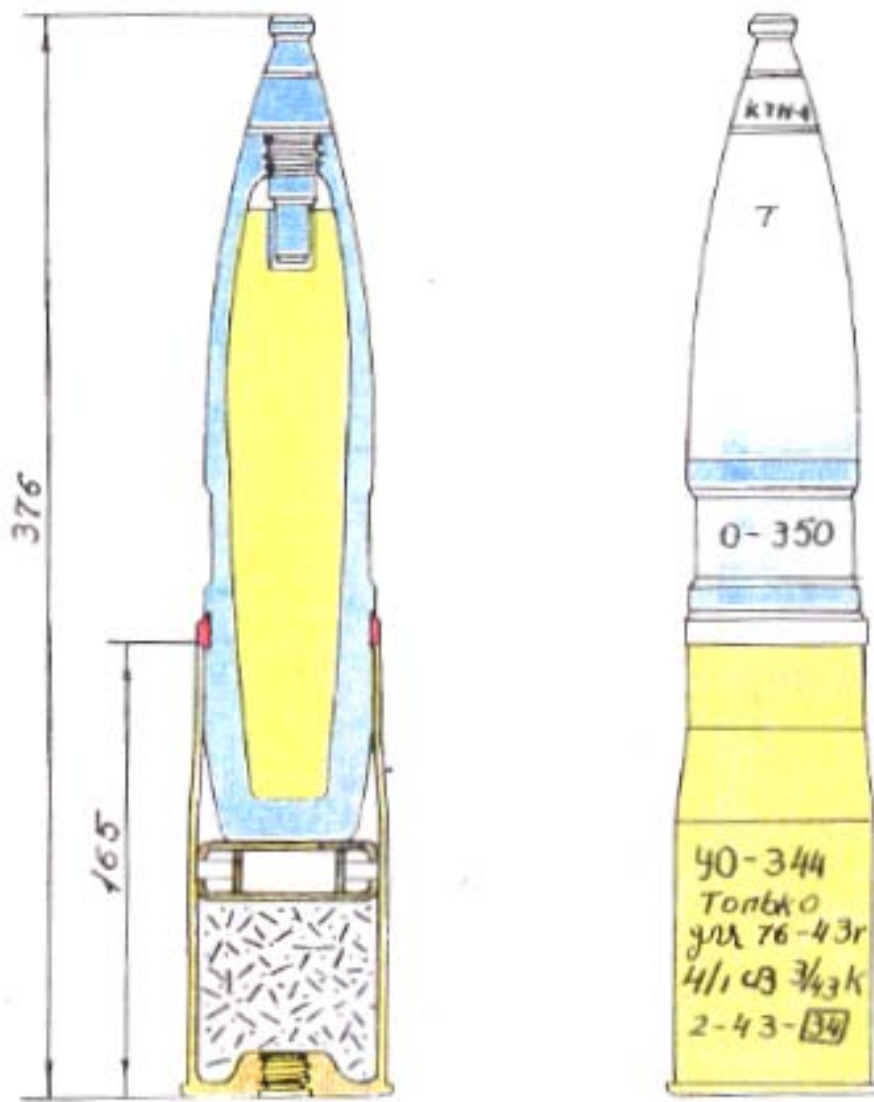

Figure 2-21 Round for 76 mm. regimental gun (model 43) with fragmentation shell.

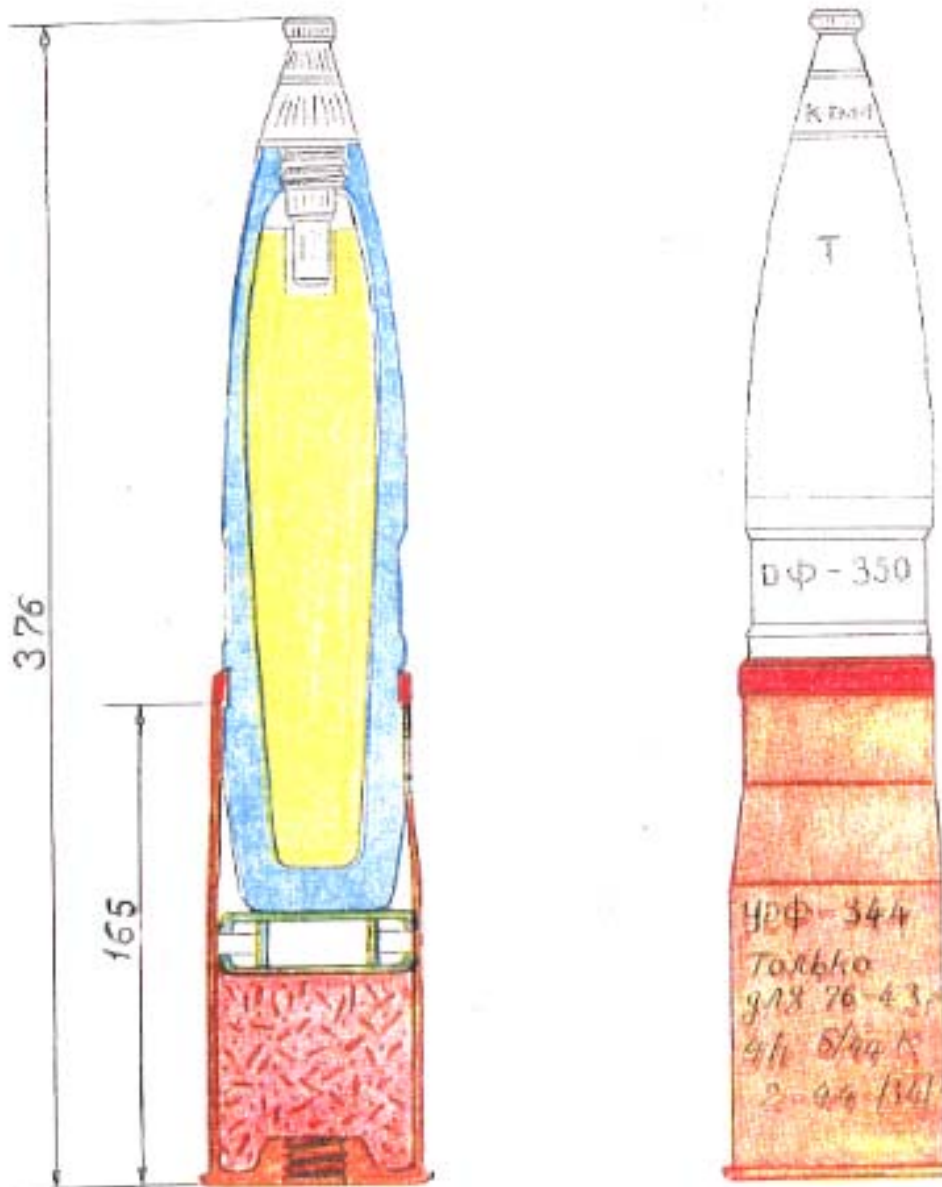

Figure 2-22 Round for 76 mm. regimental gun (model 43) with HE-fragmentation shell.

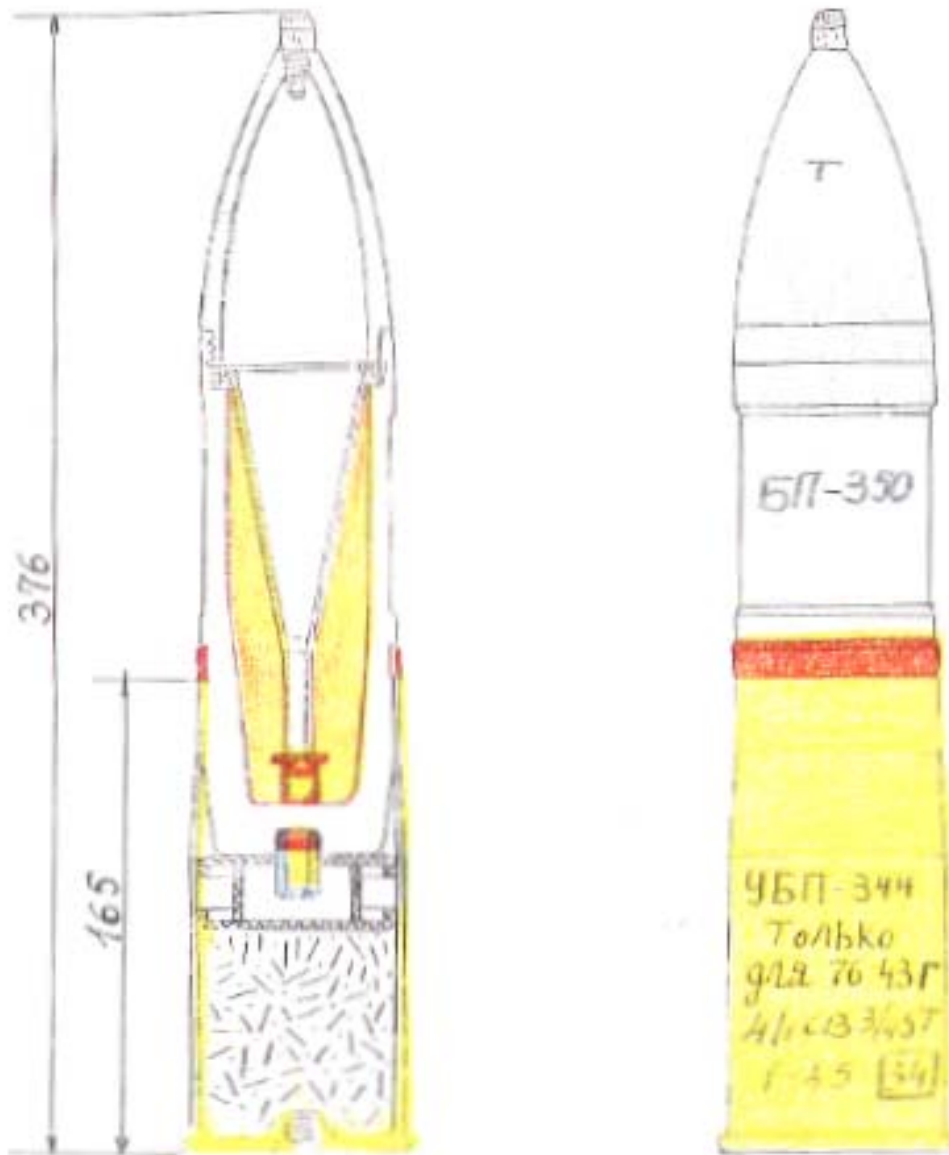

Figure 2-23 Round for 76 mm. regimental gun (model 43) with shaped charge shell.

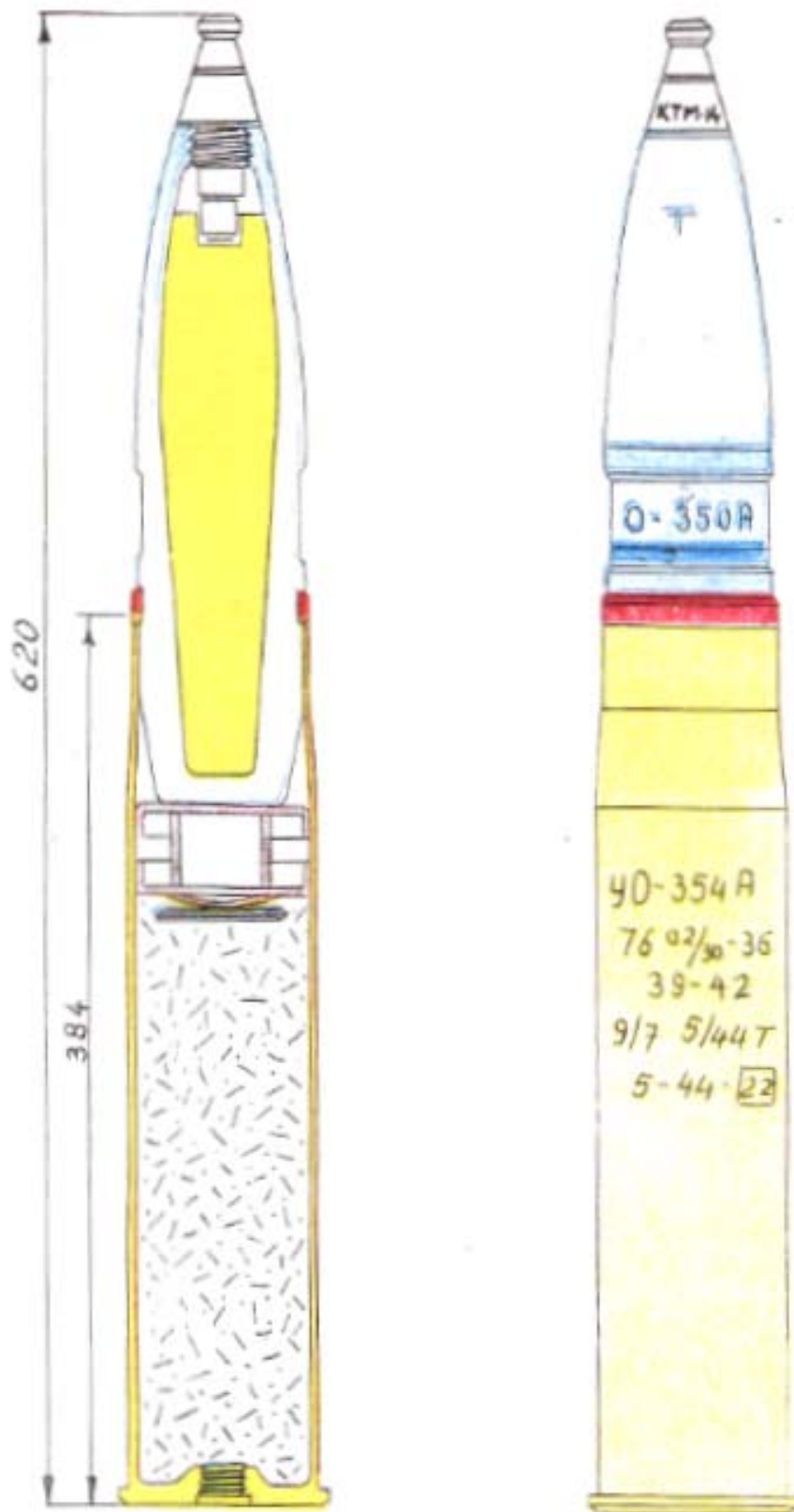

Figure 2-24 Round for 76 mm. field and SP guns with fragmentation shell.

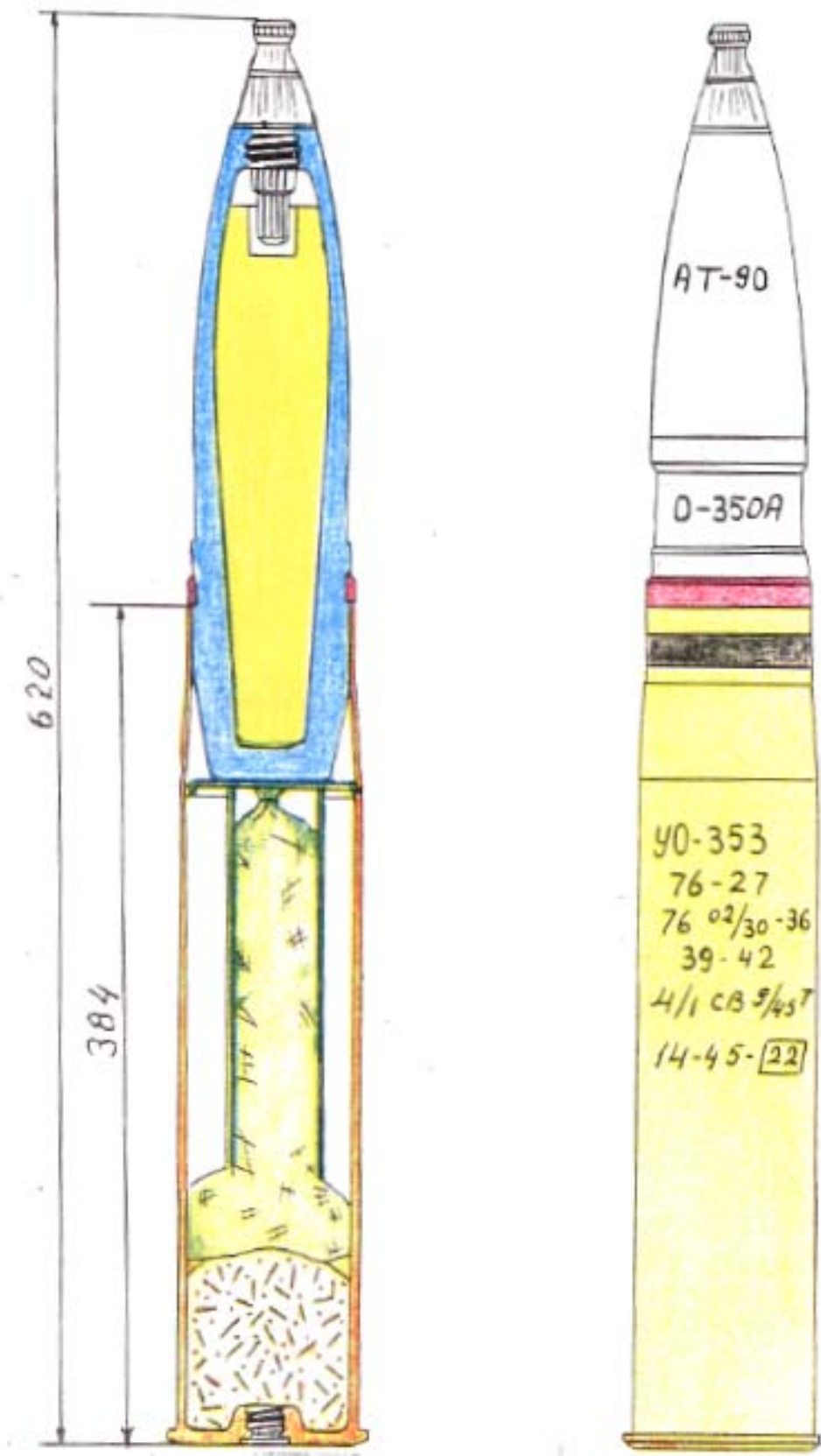

Figure 2-25 Round for 76 mm. field and SP guns with fragmentation shell (reduced charge.)

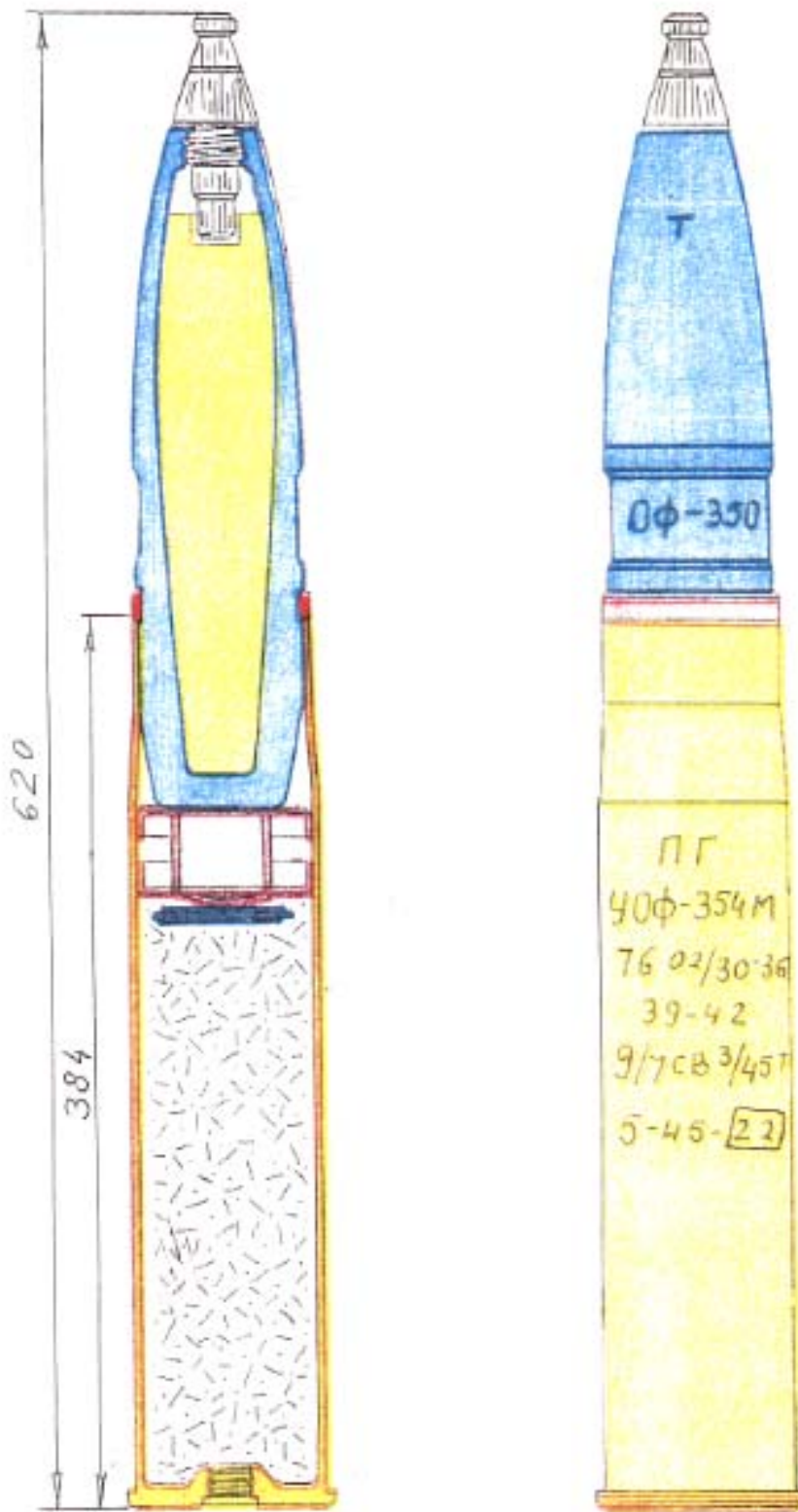

Figure 2-26 Round for 76 mm. field and SP guns with HE-fragmentation shell.

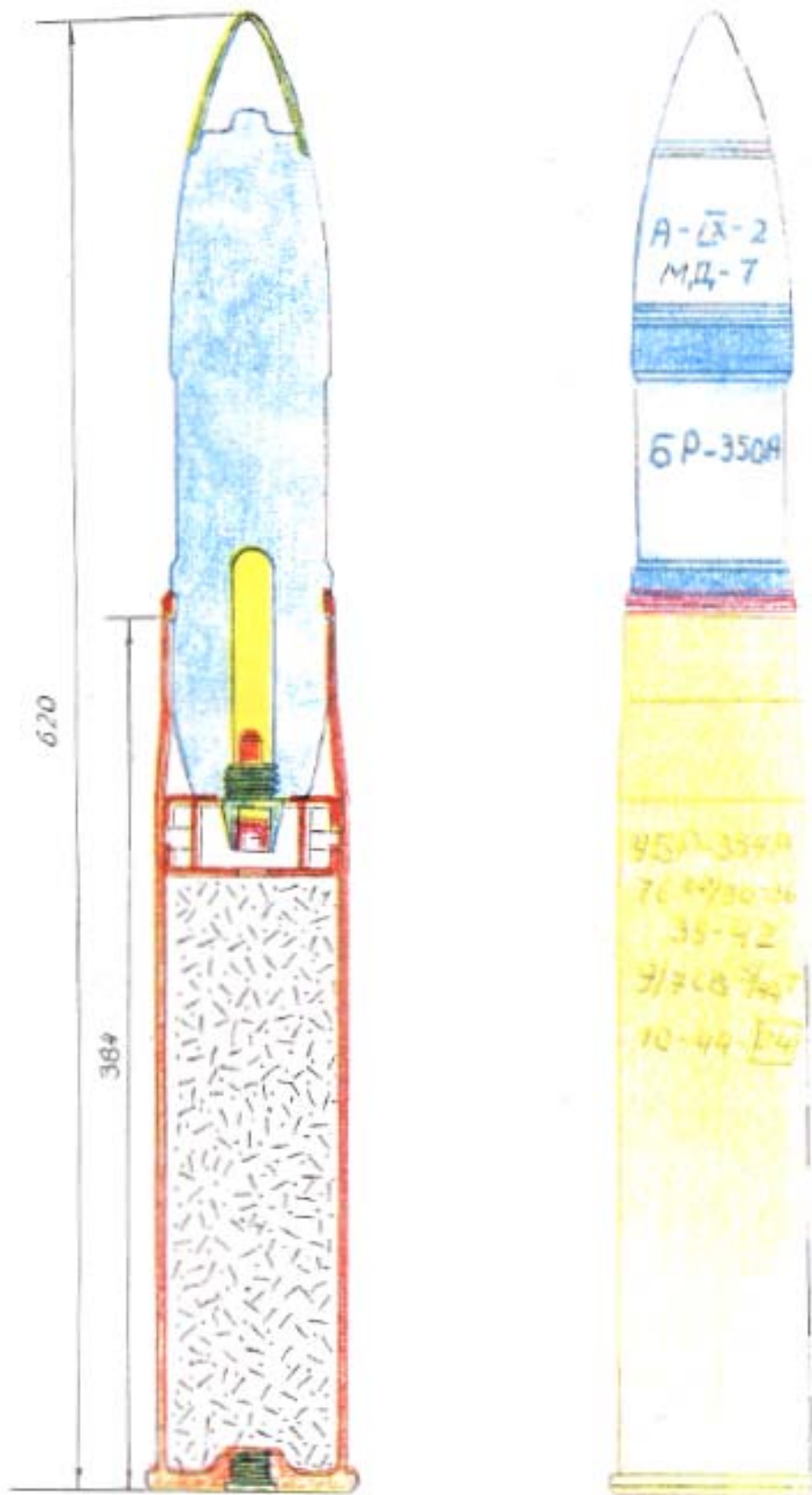

Figure 2-27 Round for 76 mm. field and SP guns with AP shell shaped as illustrated.

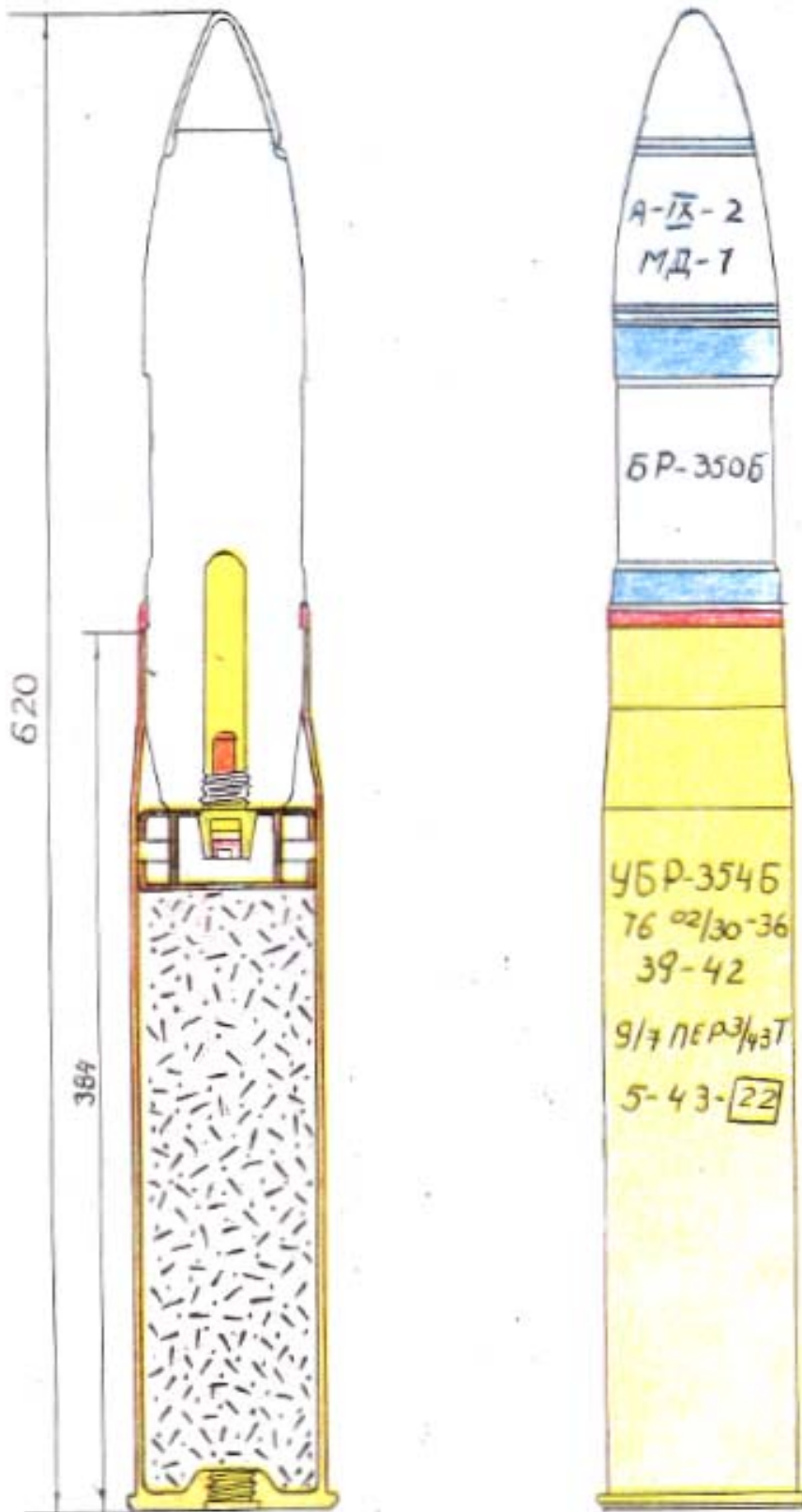

Figure 2-28 Round for 76 mm. field and SP guns with flat-nosed AP shell.

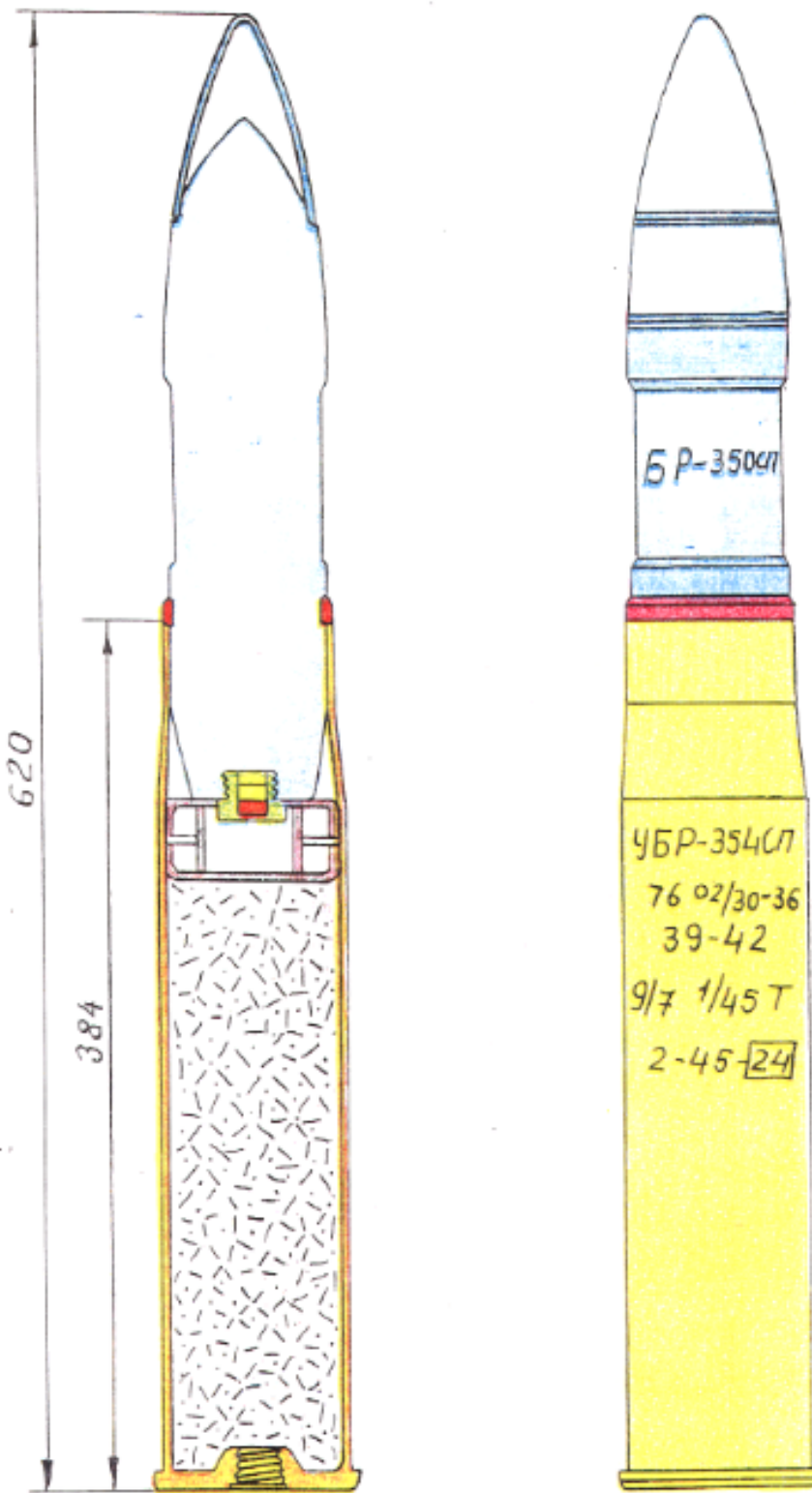

Figure 2-29 Round for 76 mm. field and SP guns with solid AP shell (with ballistic cap).

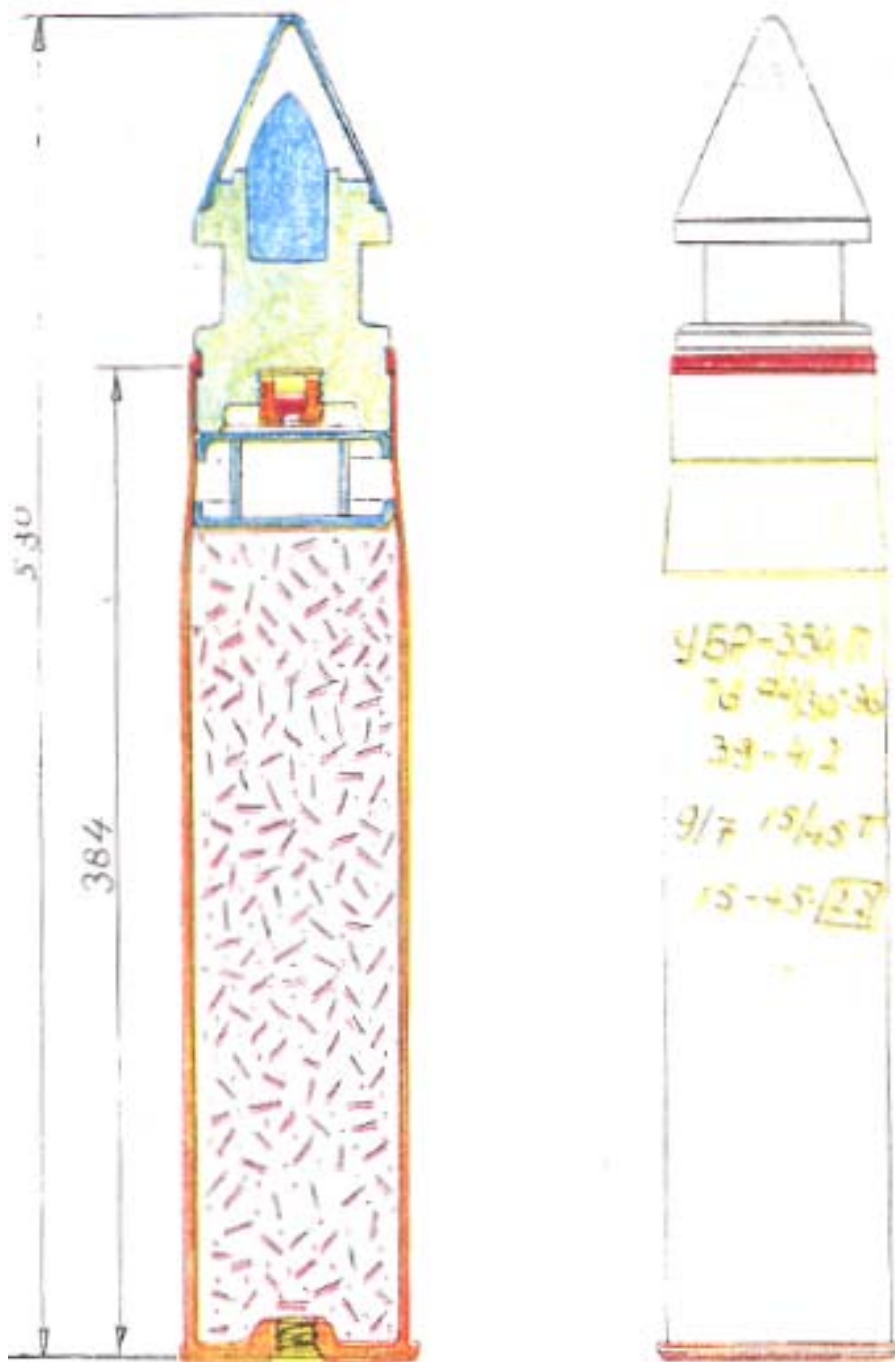

Figure 2-30 Round for 76 mm. field and SP guns with sub-calibre AP shell.

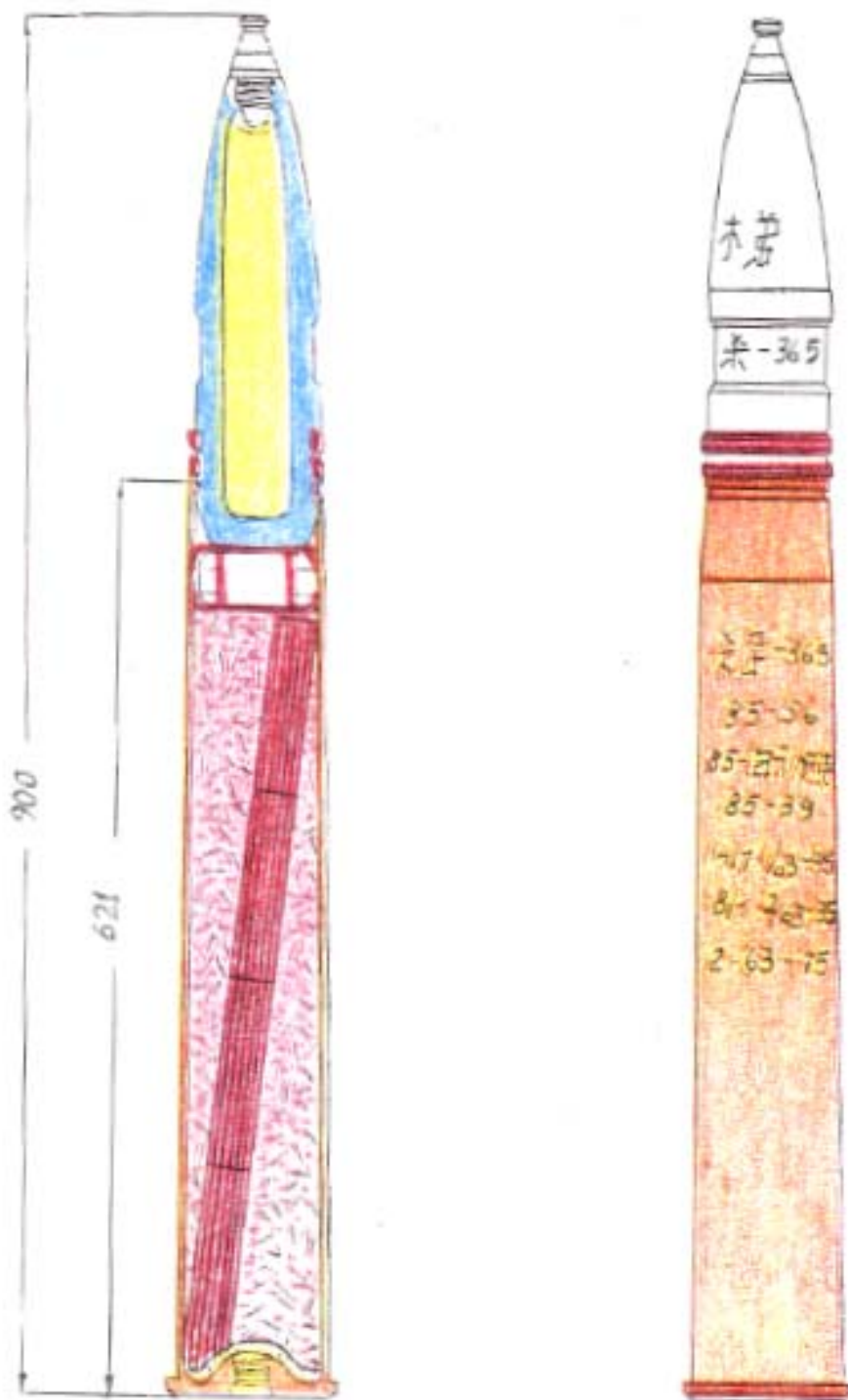

Figure 2-31 85 mm. round with steel fragmentation shell and full charge.

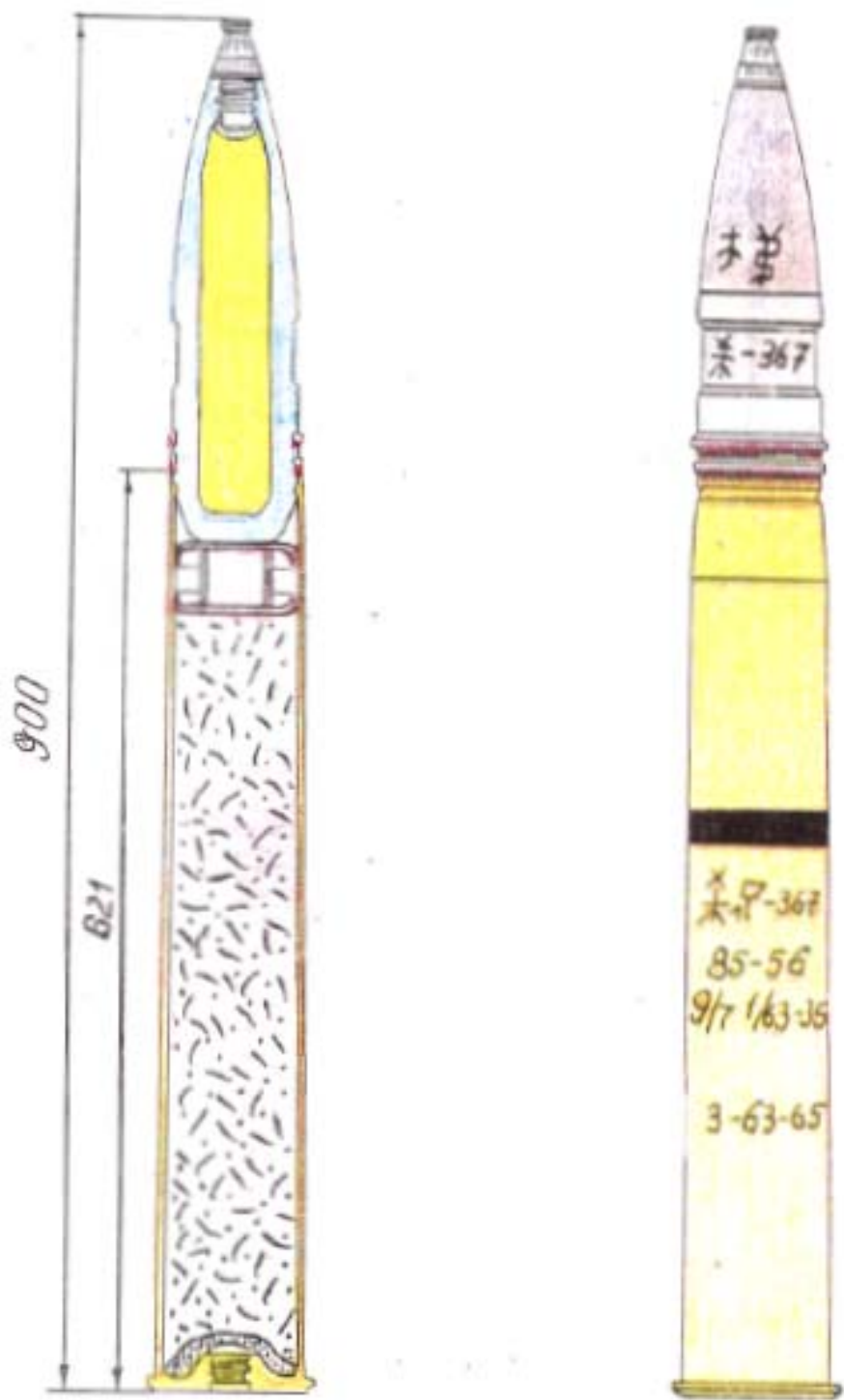

Figure 2-32 85 mm. round with steel fragmentation shell and reduced charge.

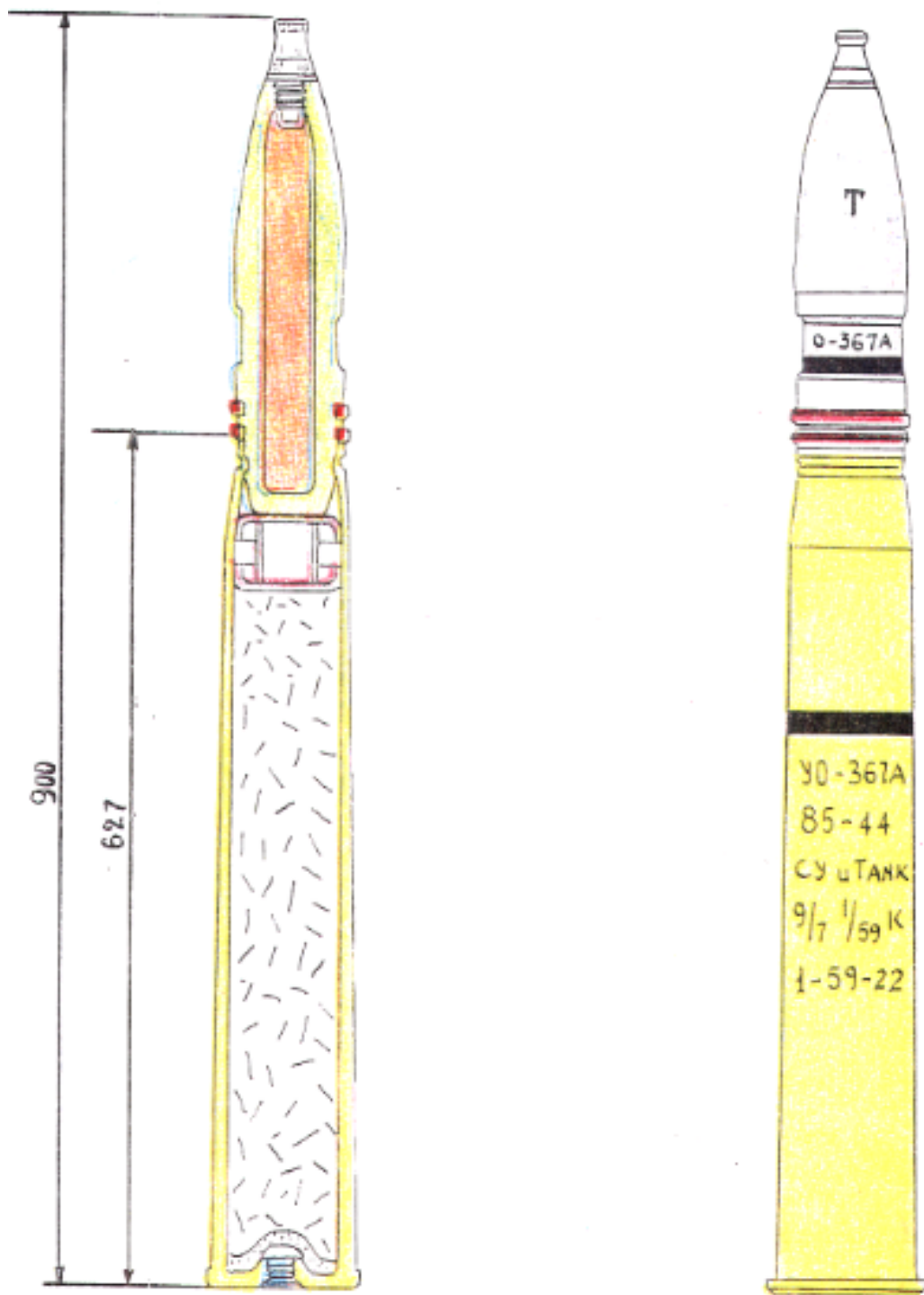

Figure 2-33 85 mm. round with cast-iron fragmentation shell and reduced charge.

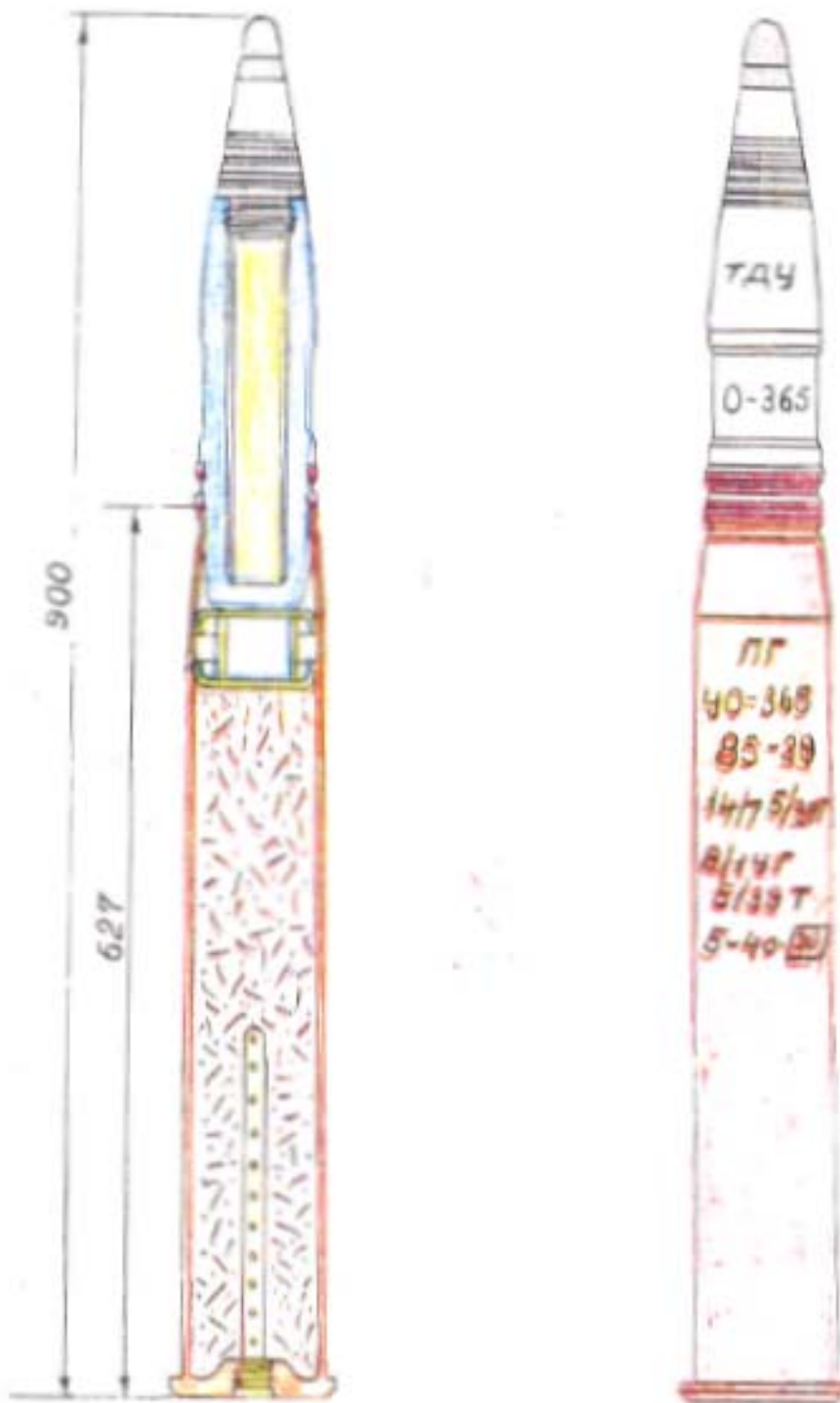

Figure 2-34 85 mm. round with AA fragmentation airburst round.

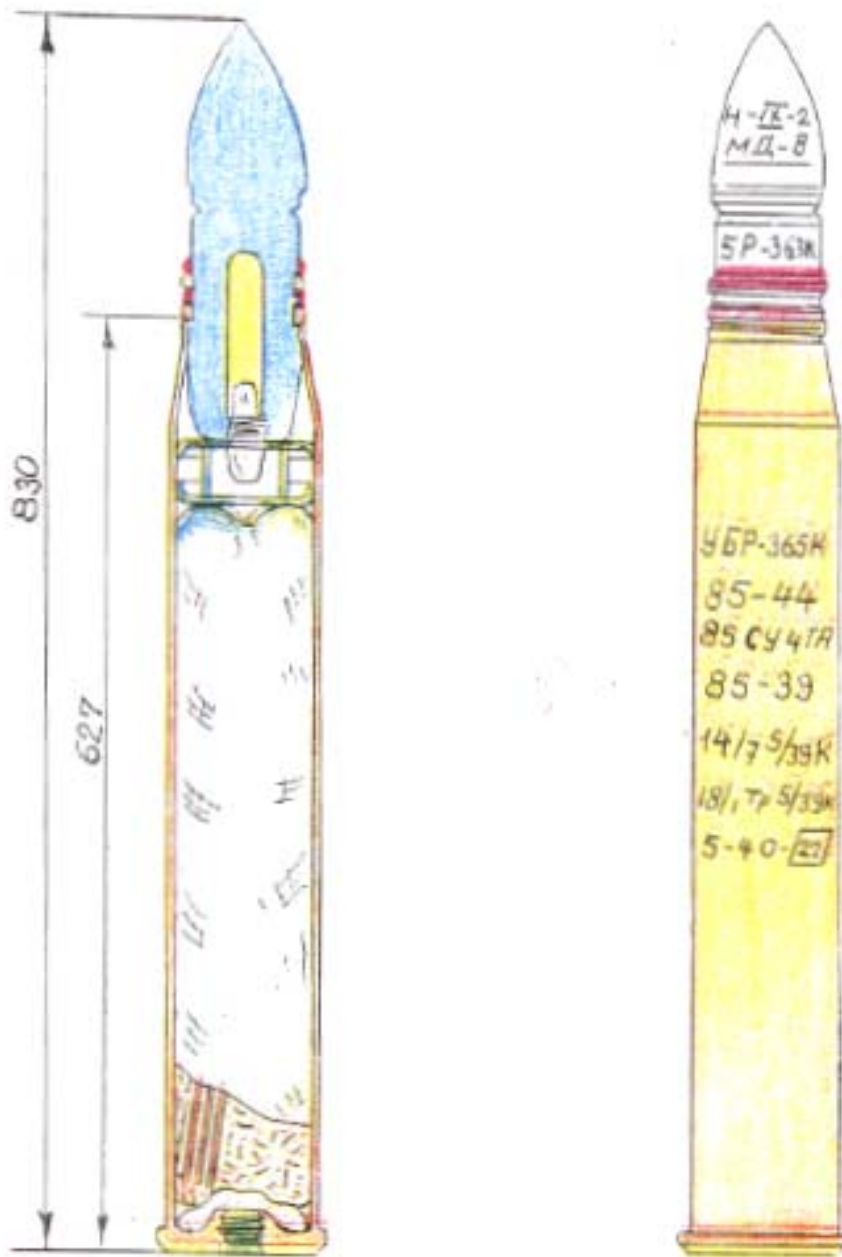

Figure 2-35 85 mm. round with sharp-nosed AP tracer shell.

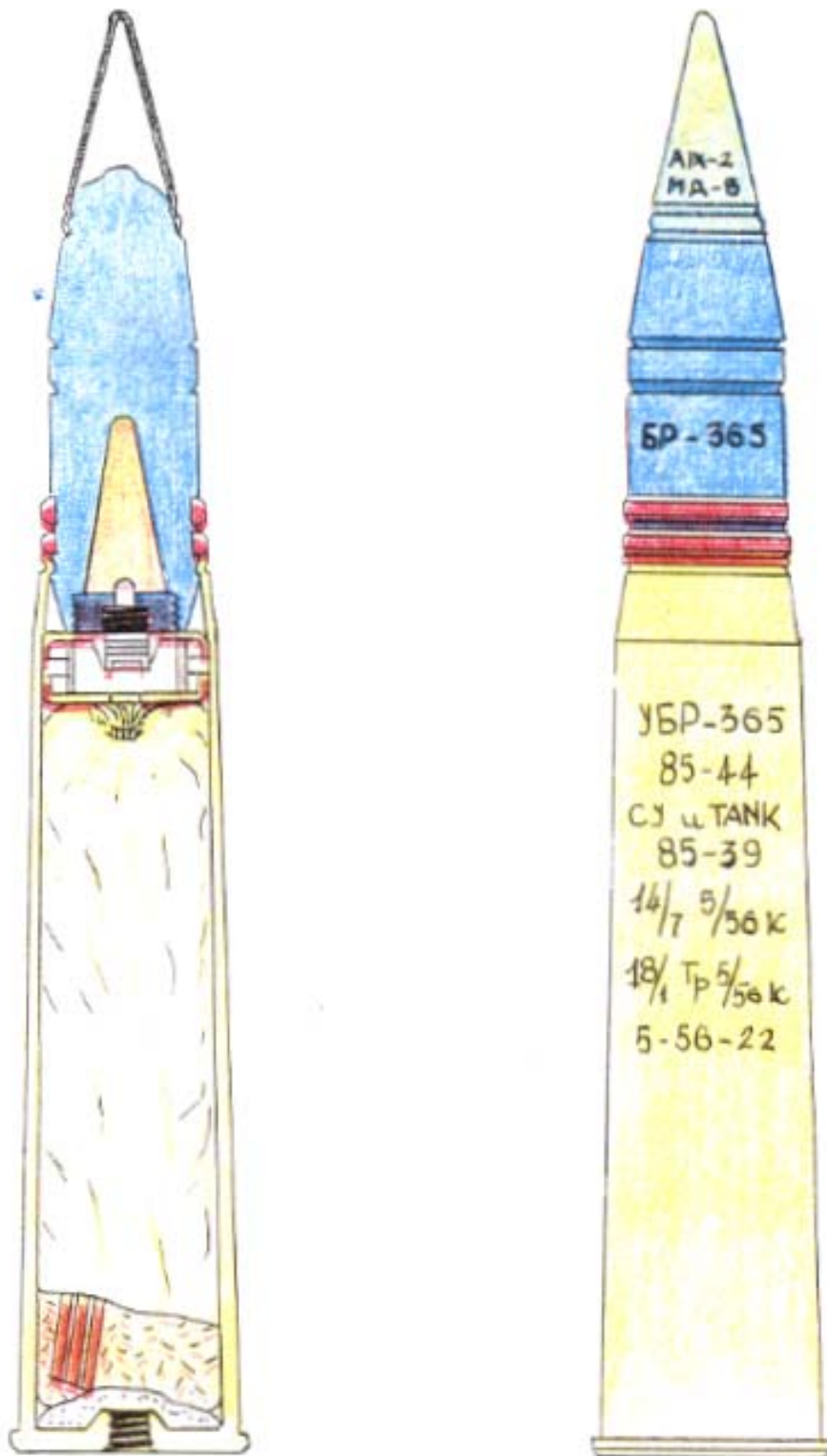

Figure 2-36 85 mm. round with blunt-nosed AP tracer shell with ballistic cap.

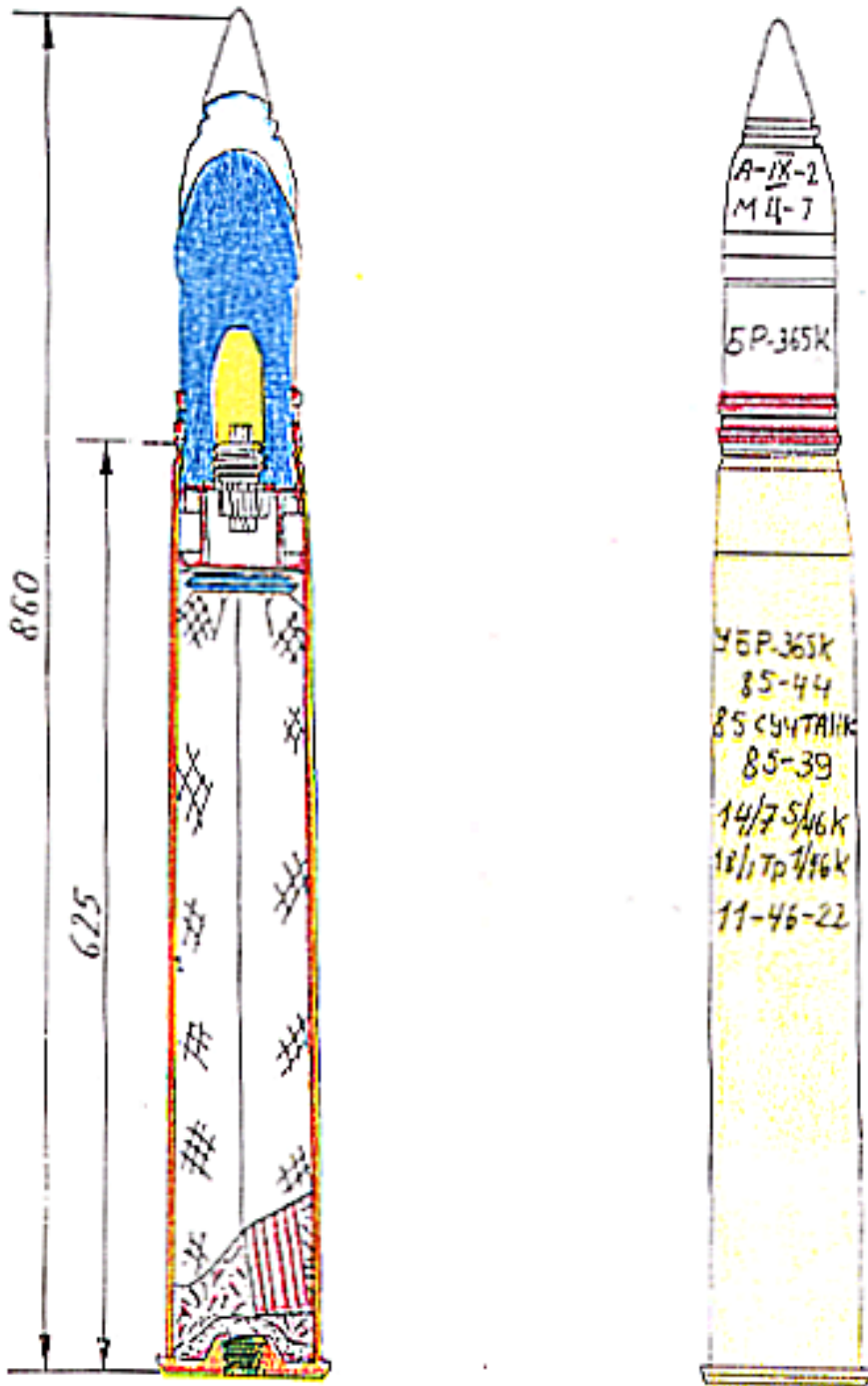

Figure 2-37 85 mm. round with AP tracer shell with AP nose and ballistic cap.

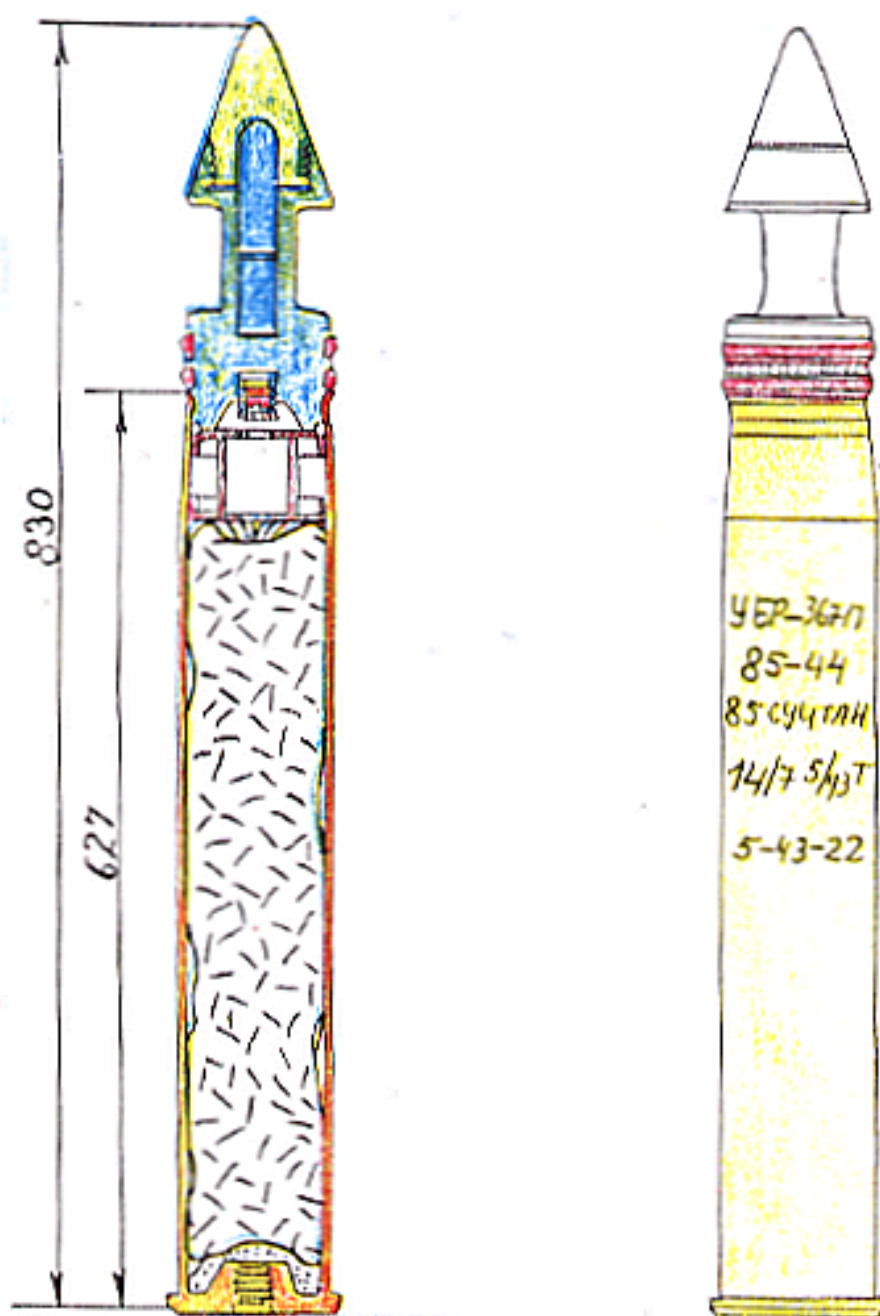

Figure 2-38 85 mm. round with sub-calibre AP tracer shell.

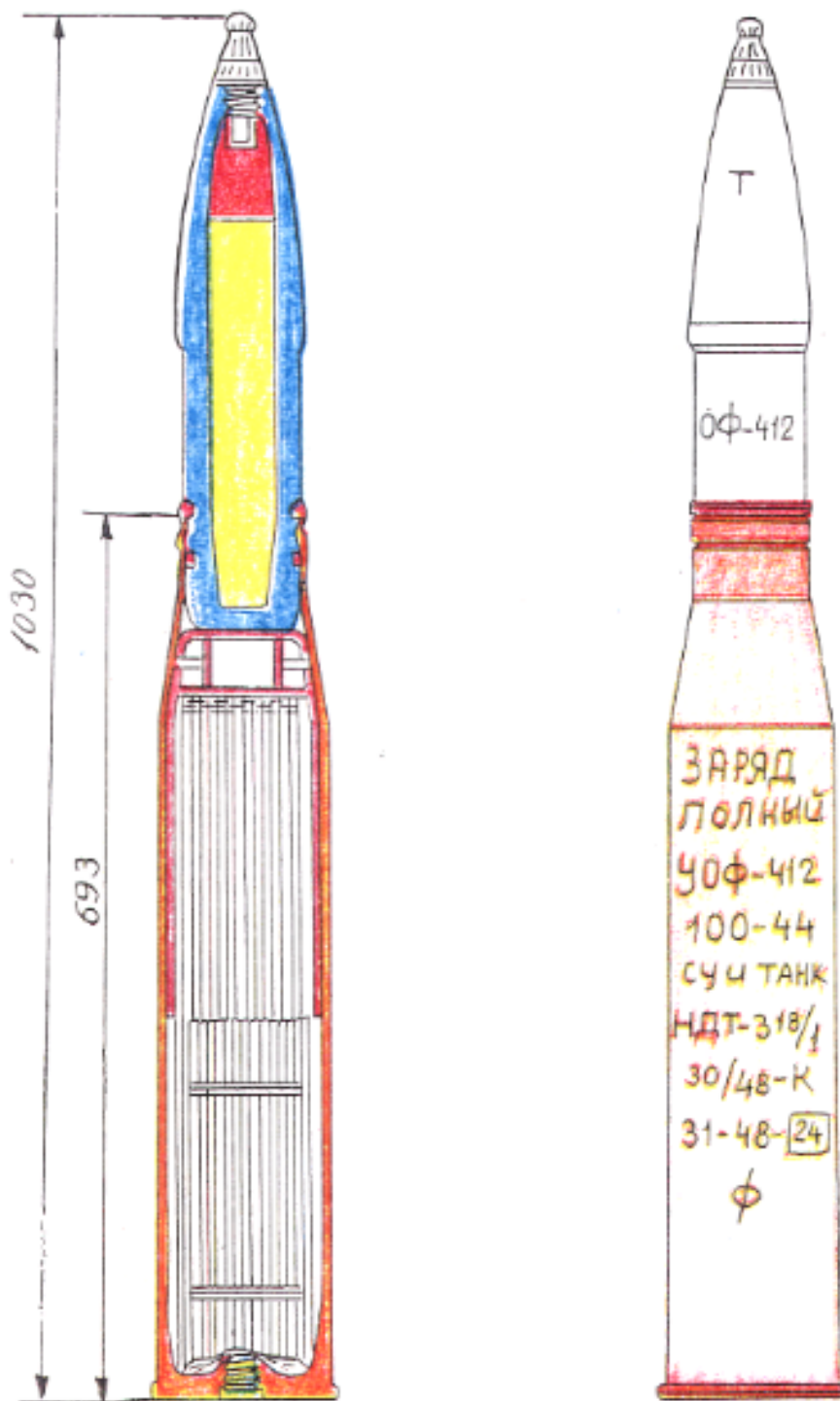

Figure 2-39 100 mm. round with full charge and HE fragmentation shell.

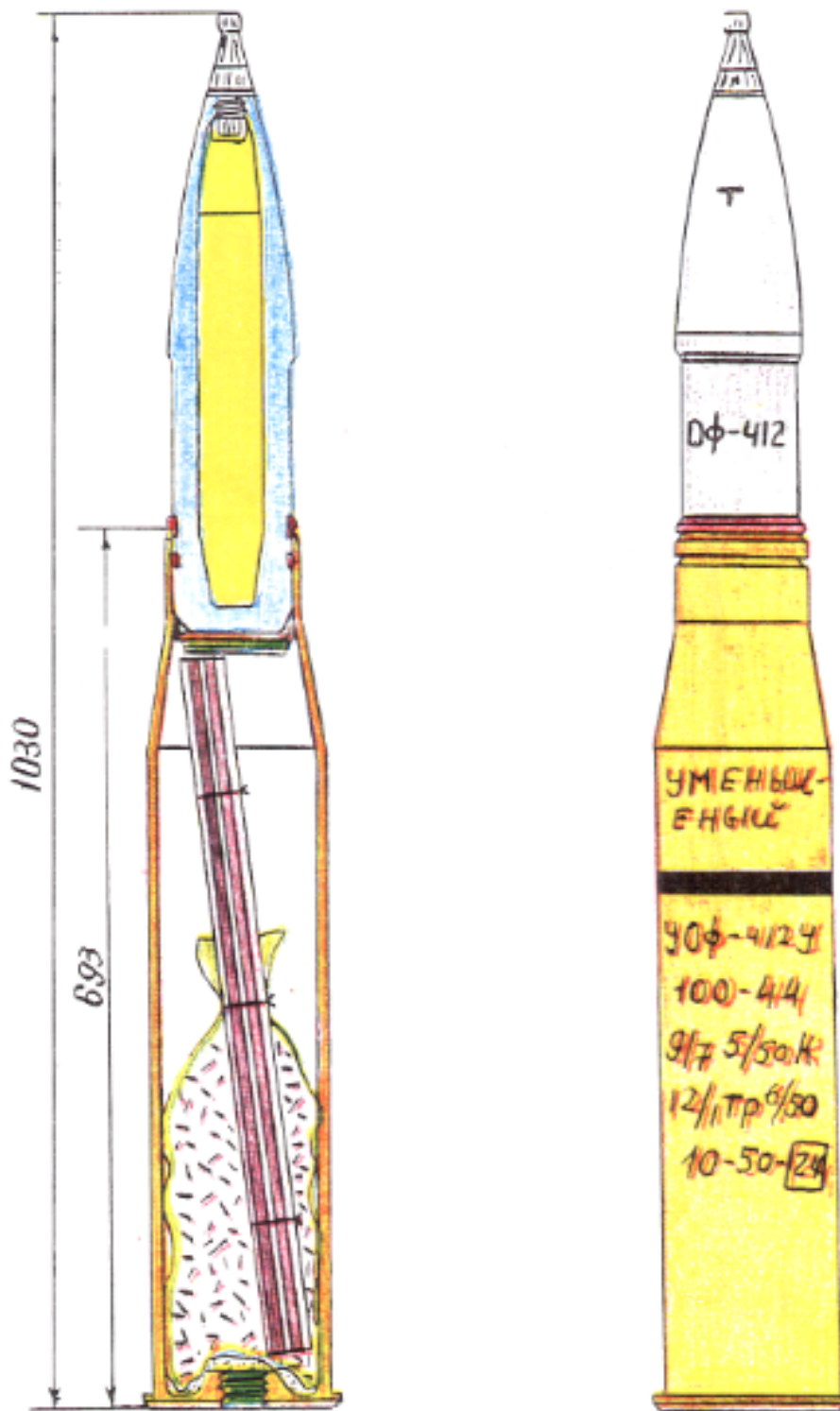

Figure 2-40 100 mm. round with reduced charge and HE fragmentation shell.

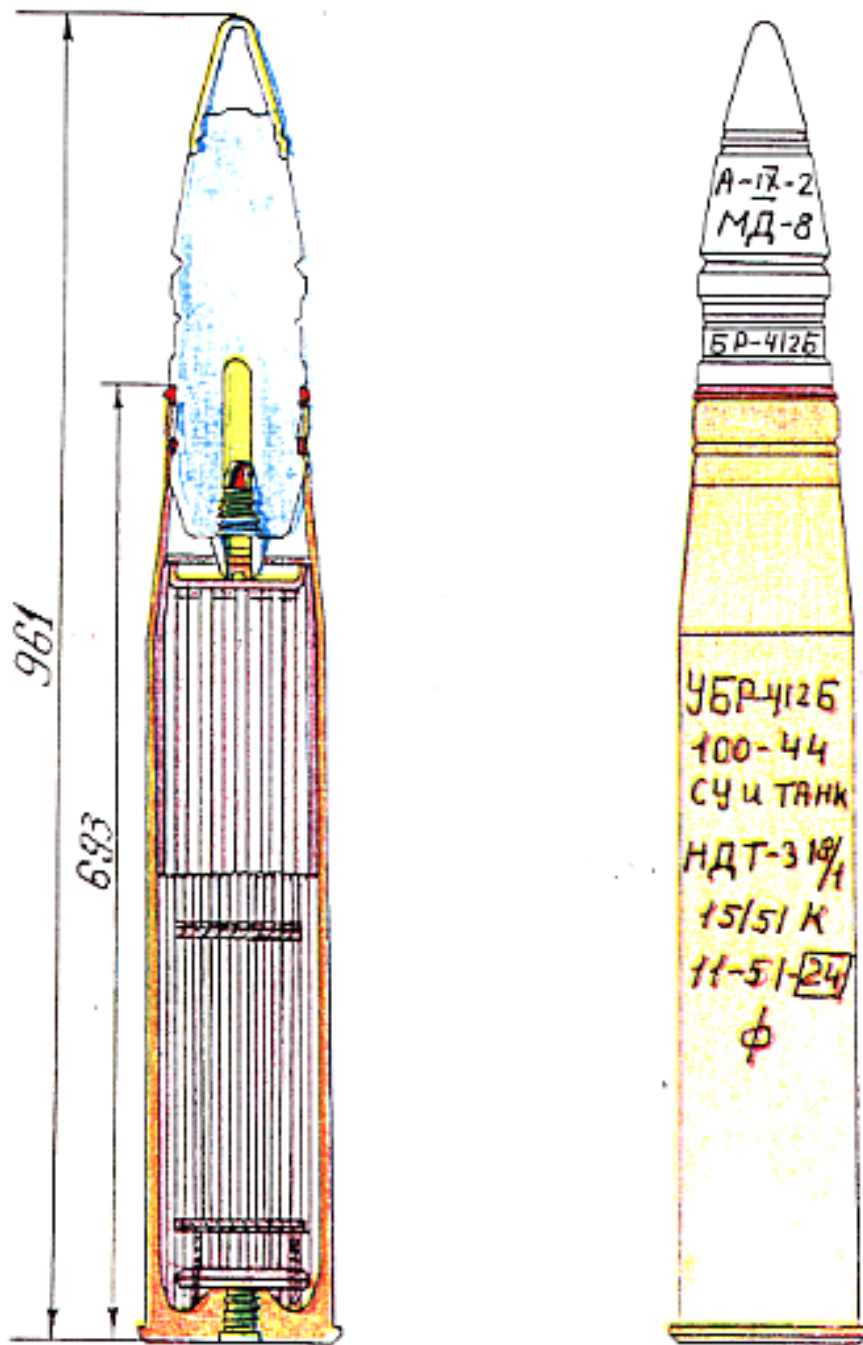

Figure 2-41 100 mm. round with blunt-nosed AP tracer shell and ballistic cap.

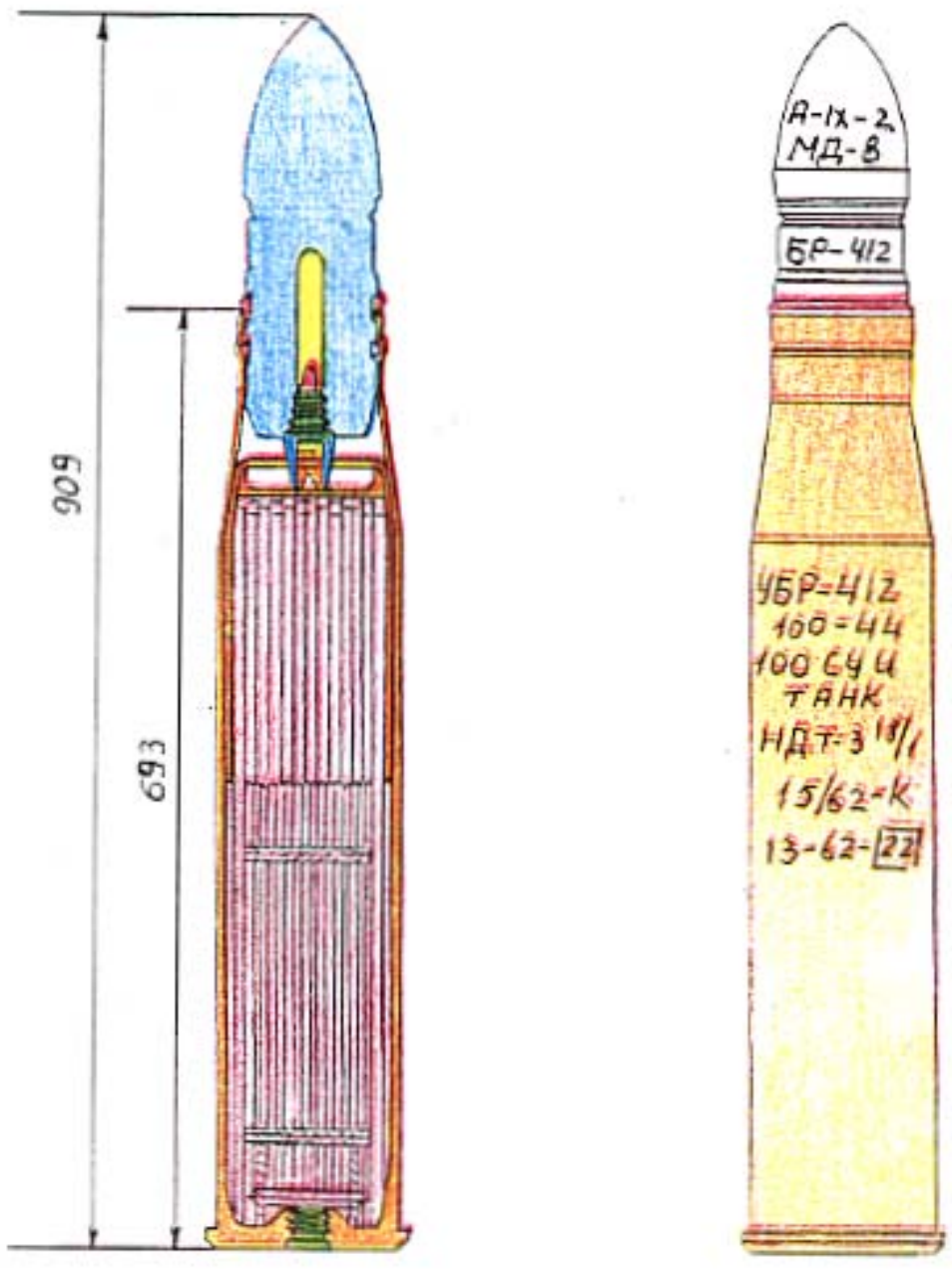

Figure 2-42 100 mm. round with sharp-nosed AP tracer shell.

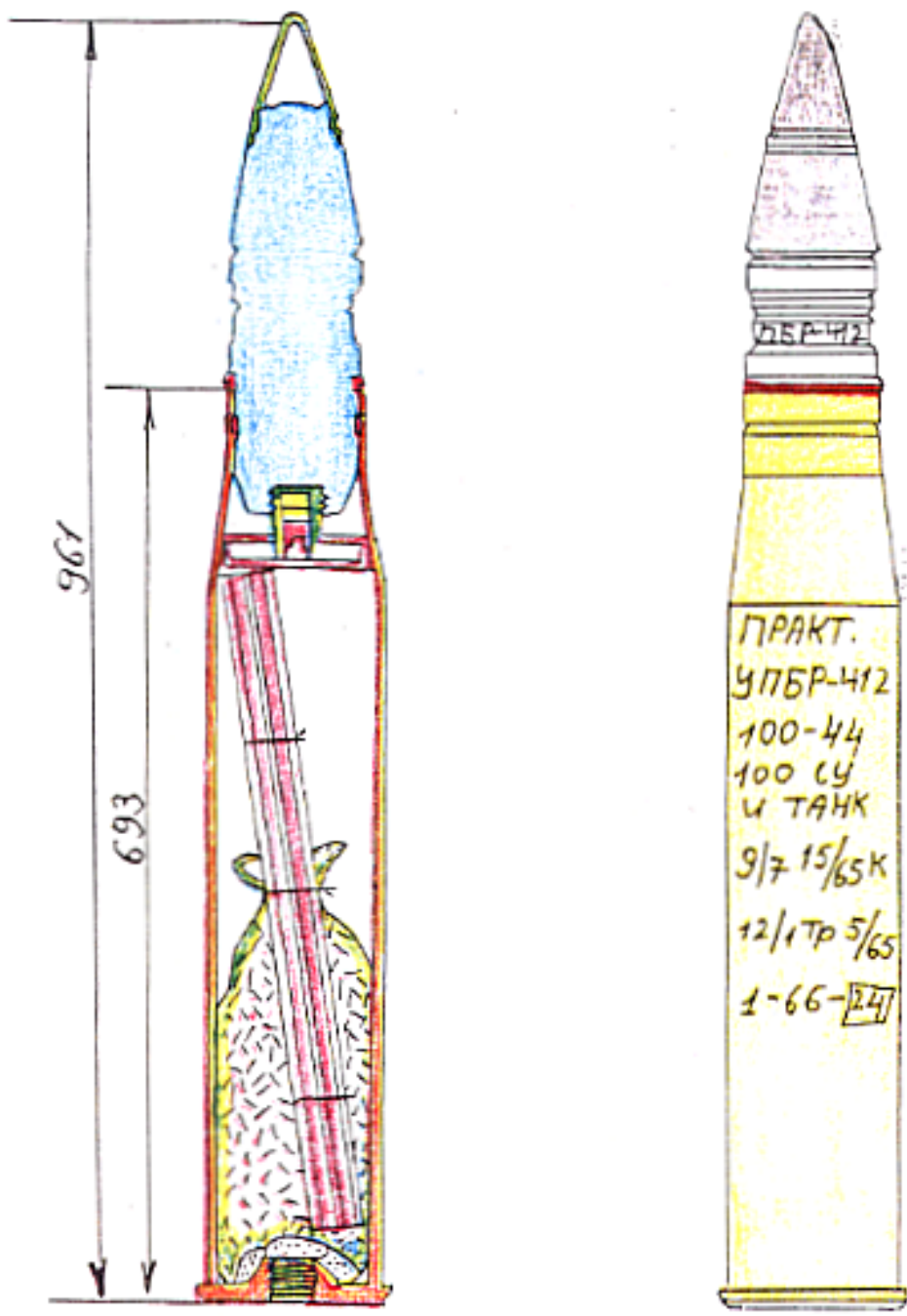

Figure 2-43 100 mm. round with reduced charge and practice tracer shell.

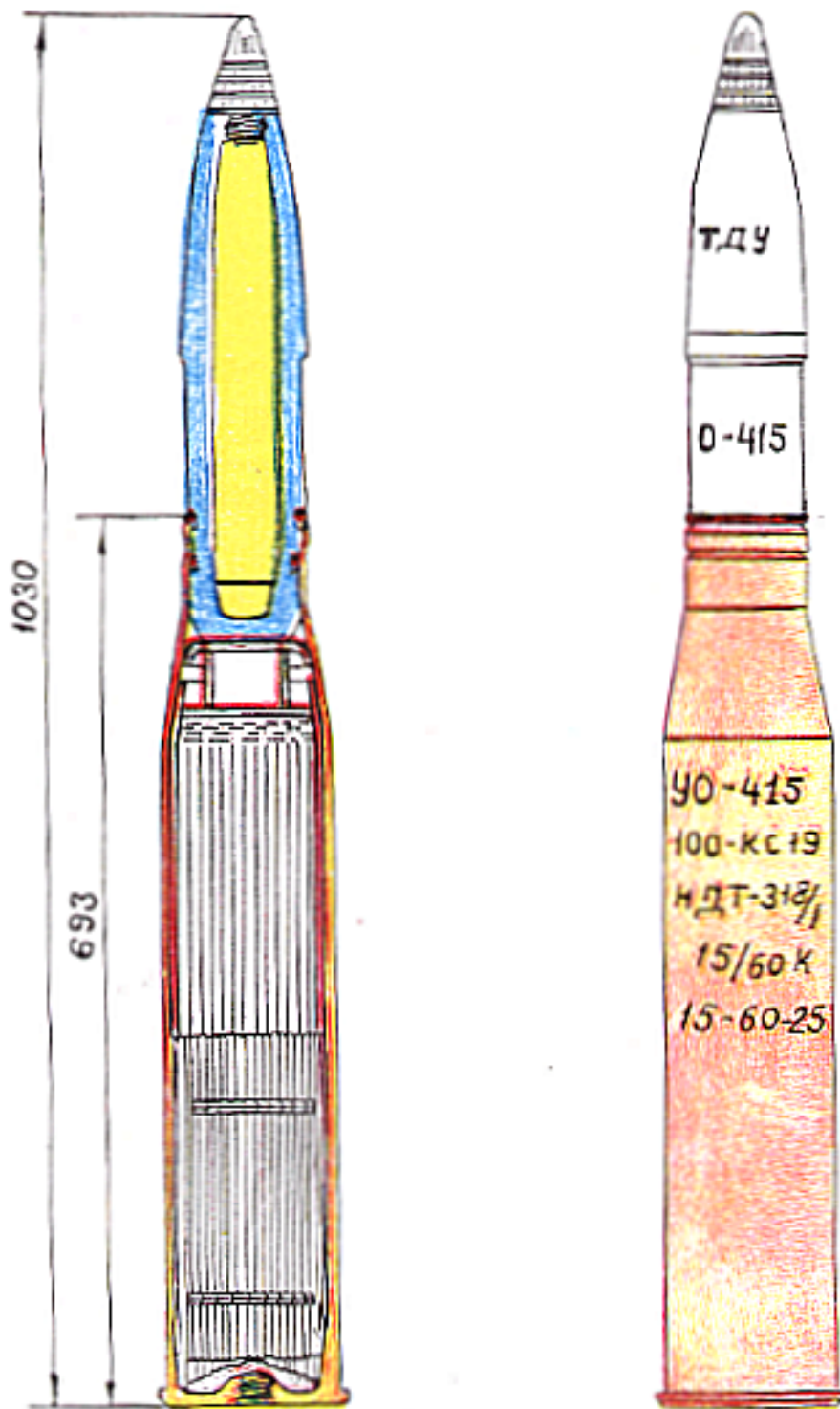

Figure 2-44 Round for 100 mm. AA gun with fragmentation airburst shell.

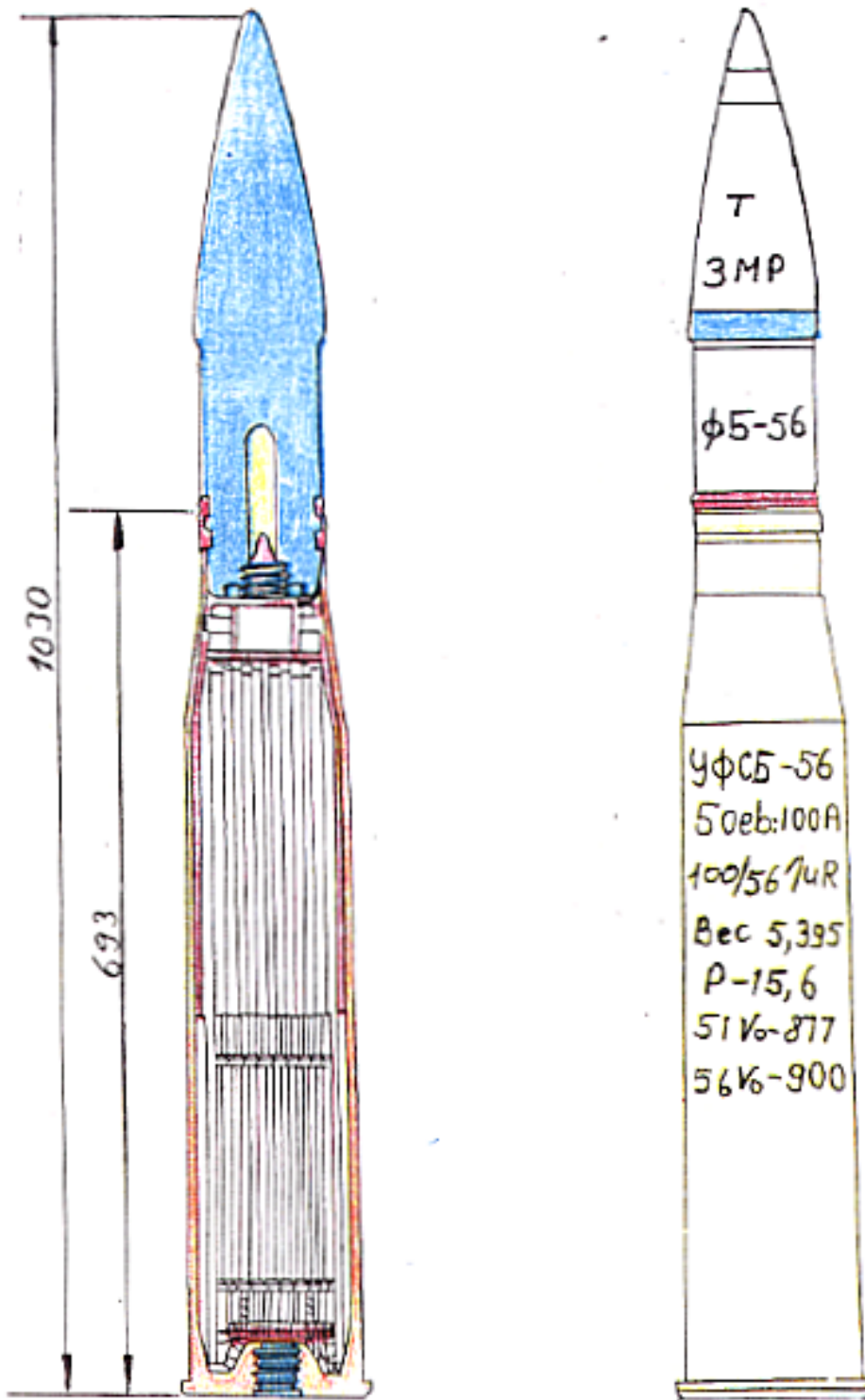

Figure 2-45 Round for 100 mm. coastal artillery gun (mechanical extraction) with full charge and HE shell.

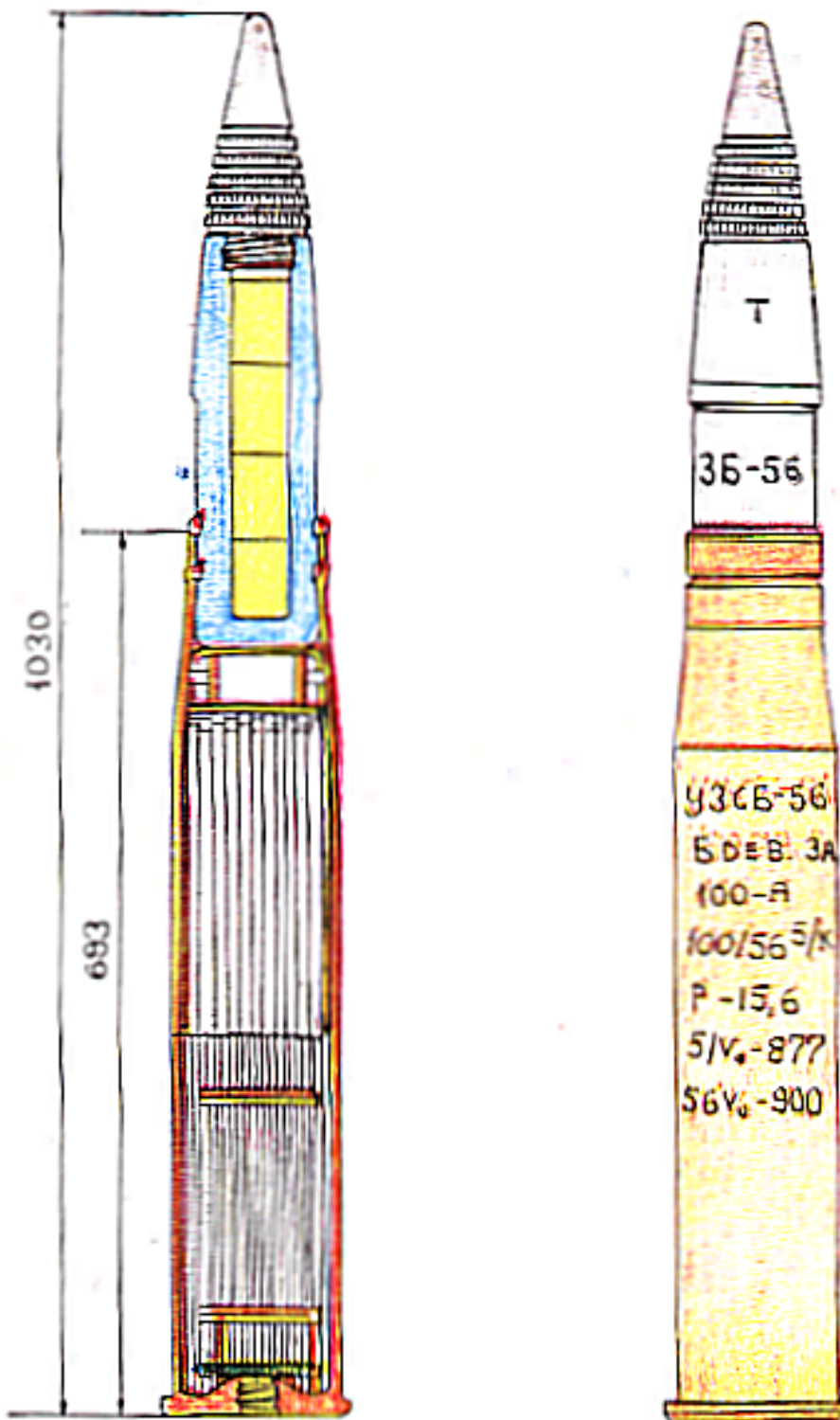

Figure 2-46 Round for 100 mm. coastal artillery gun(mechanical extraction) with full charge and fragmentation airburst shell.

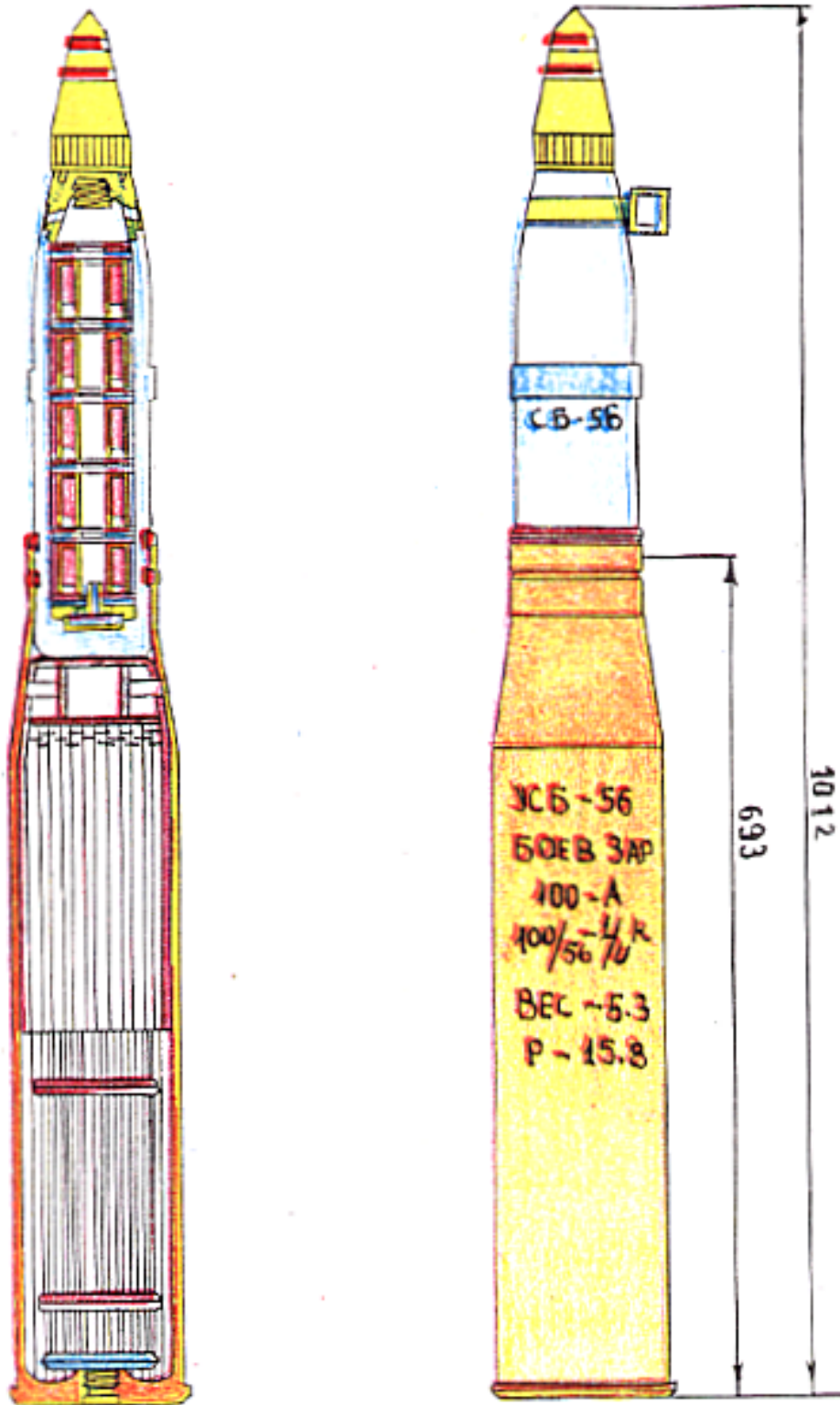

Figure 2-47 Round for 100 mm. coastal artillery gun (mechanical extraction) with reduced charge and practice shell.

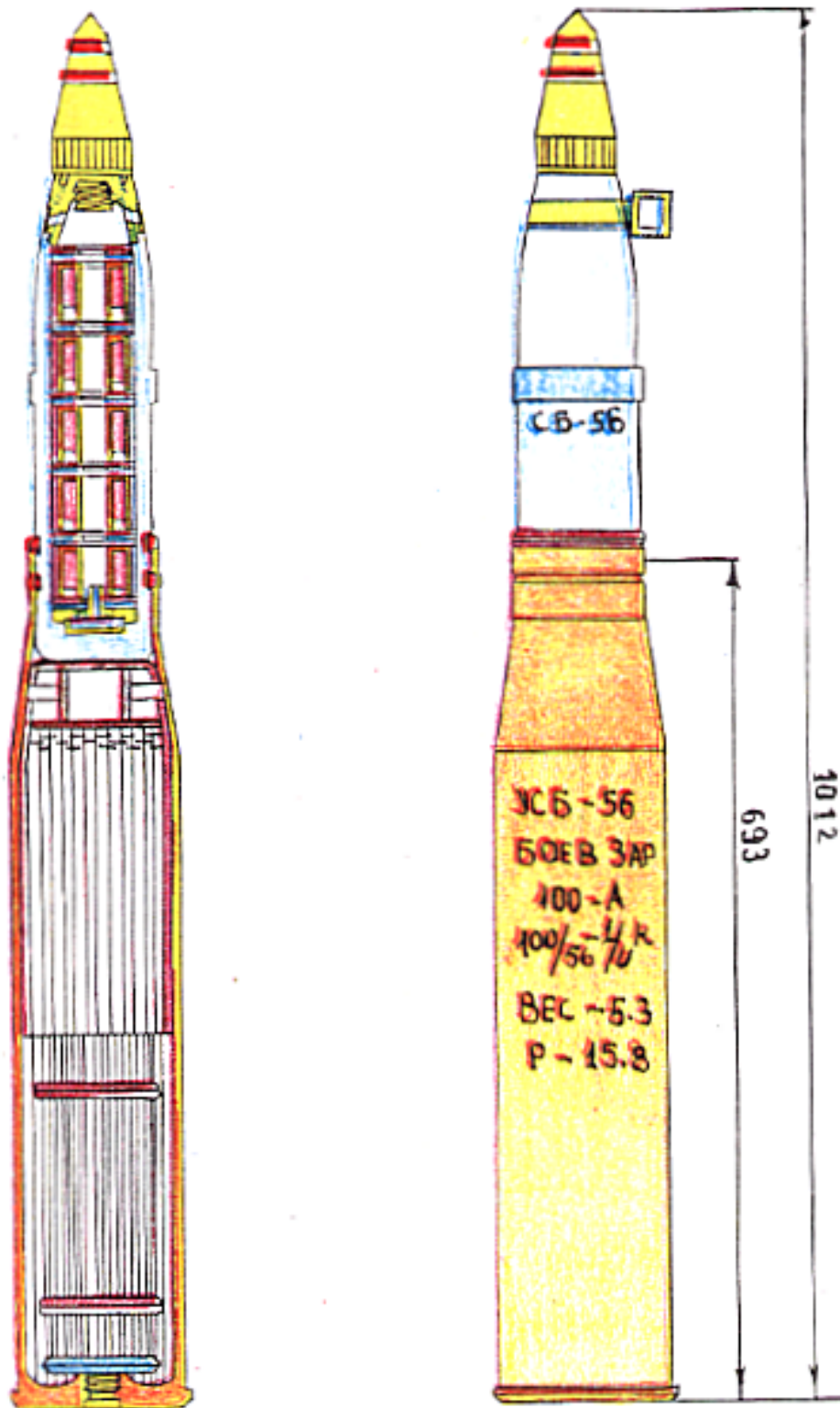

Figure 2-48 Round for 100 mm. coastal artillery gun (mechanical extraction) with illuminating shell.

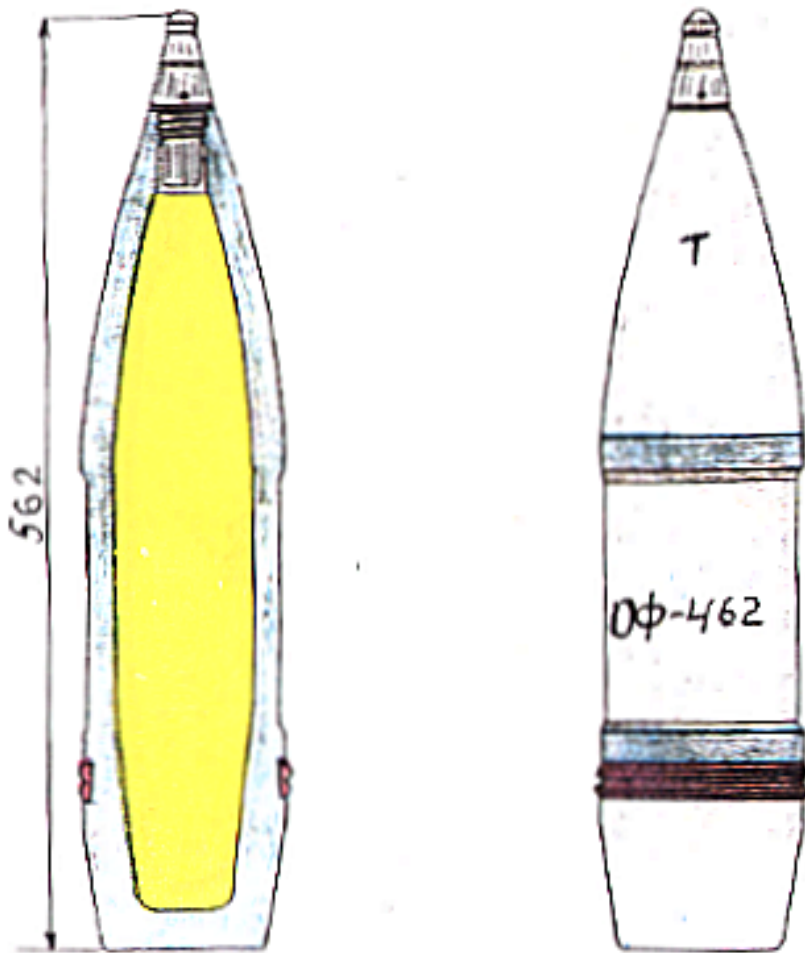

Figure 2-49 122 mm. HE-fragmentation shell for model 54 (38) howitzer.

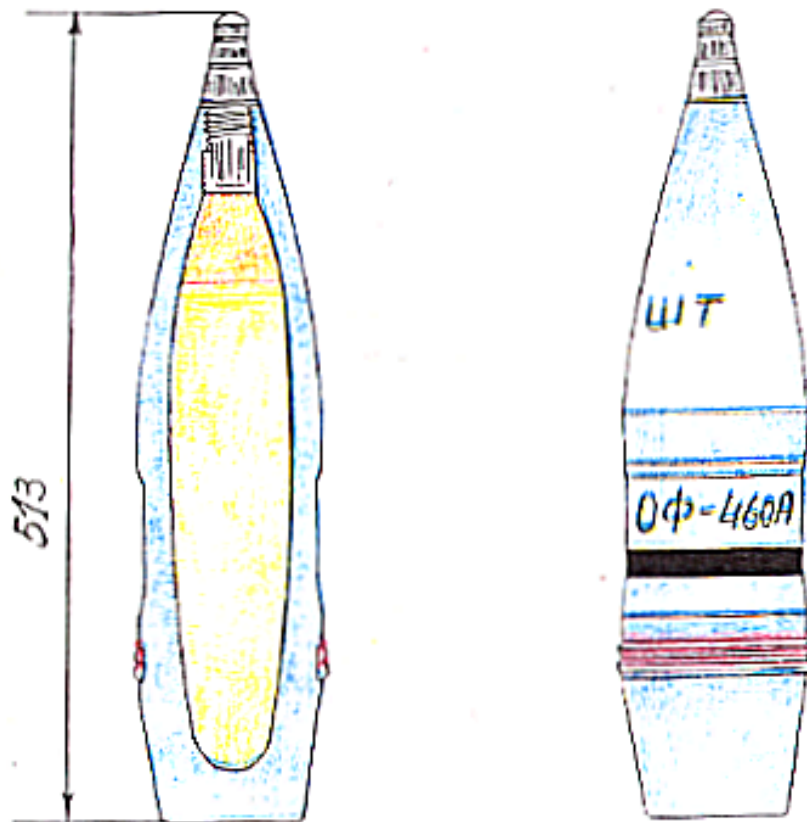

Figure 2-50 Cast-iron one-piece fragmentation shell for 122 mm. howitzer model 54 (38).

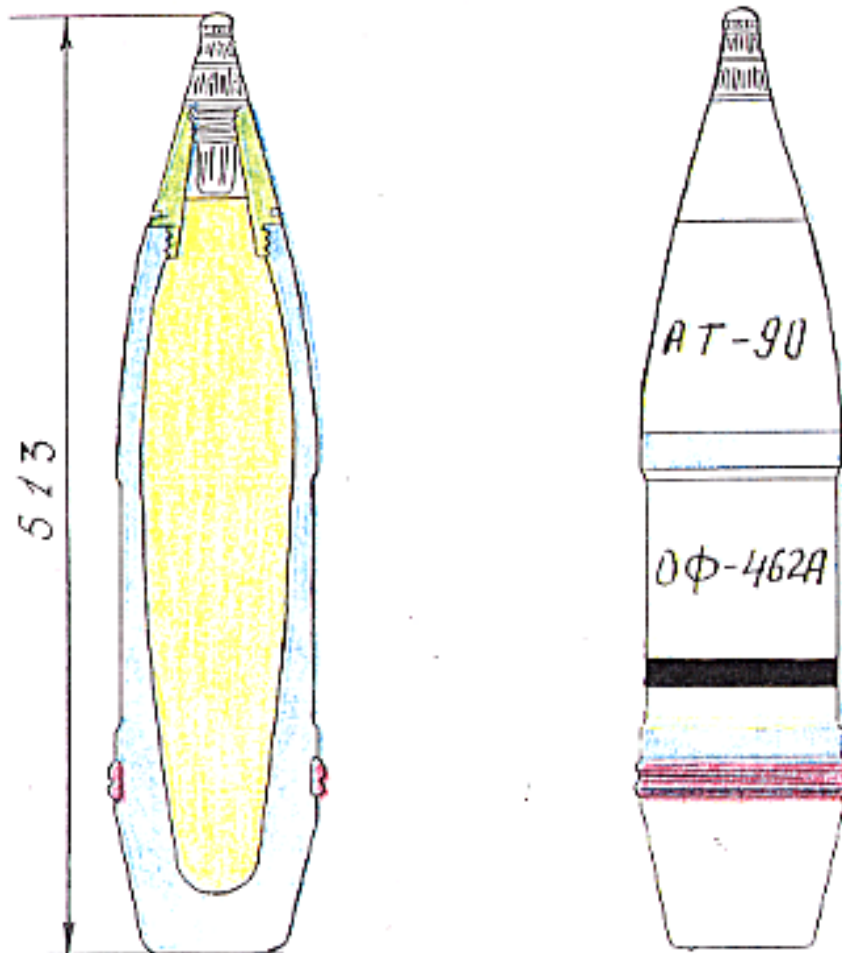

Figure 2-51 Cast-iron fragmentation shell howitzer with screwed-in nose-piece for 122 mm. howitzer model 54 (38).

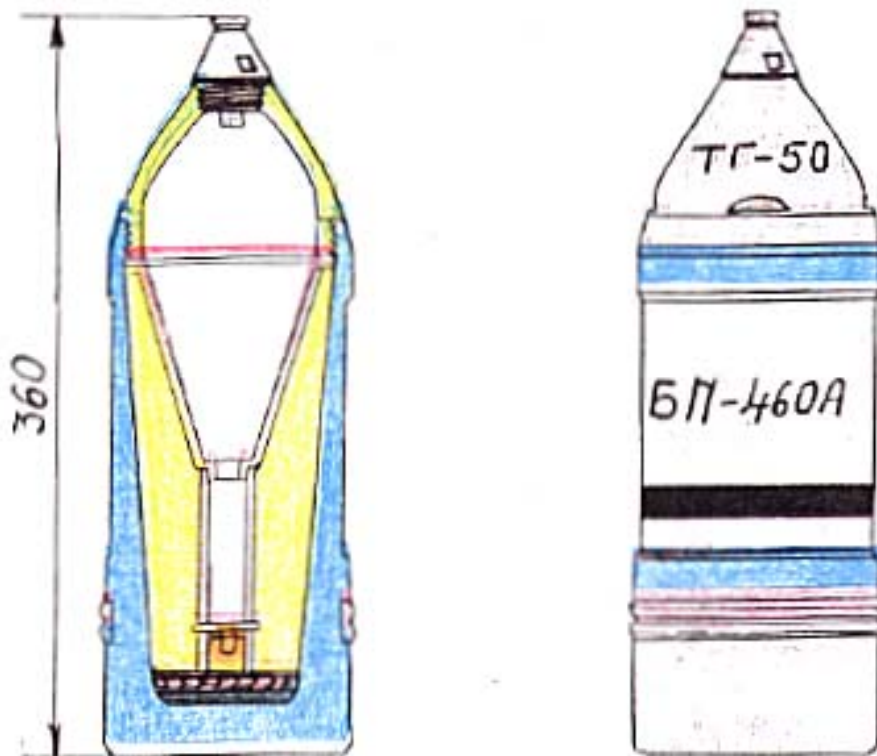

Figure 2-52 Cast-iron shaped charge shell for 122 mm. howitzer model 54 (38).

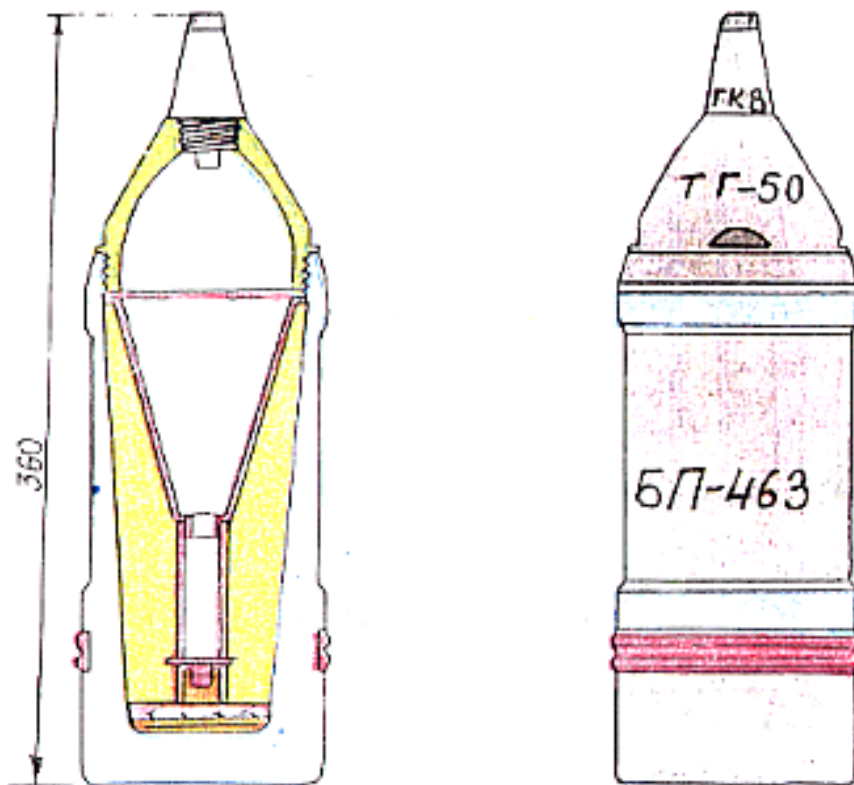

Figure 2-53 Steel shaped charge shell for 122 mm. howitzer model 54 (38).

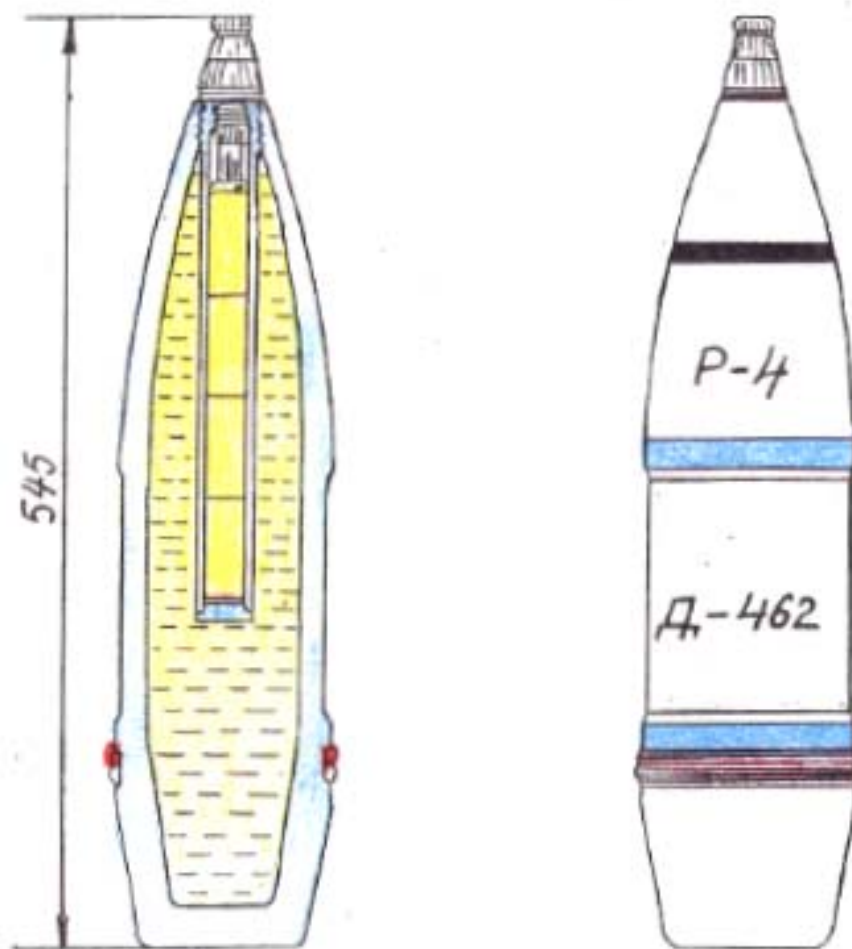

Figure 2-54 Steel smoke shell for 122 mm. howitzer model 54 (38).122 mm.

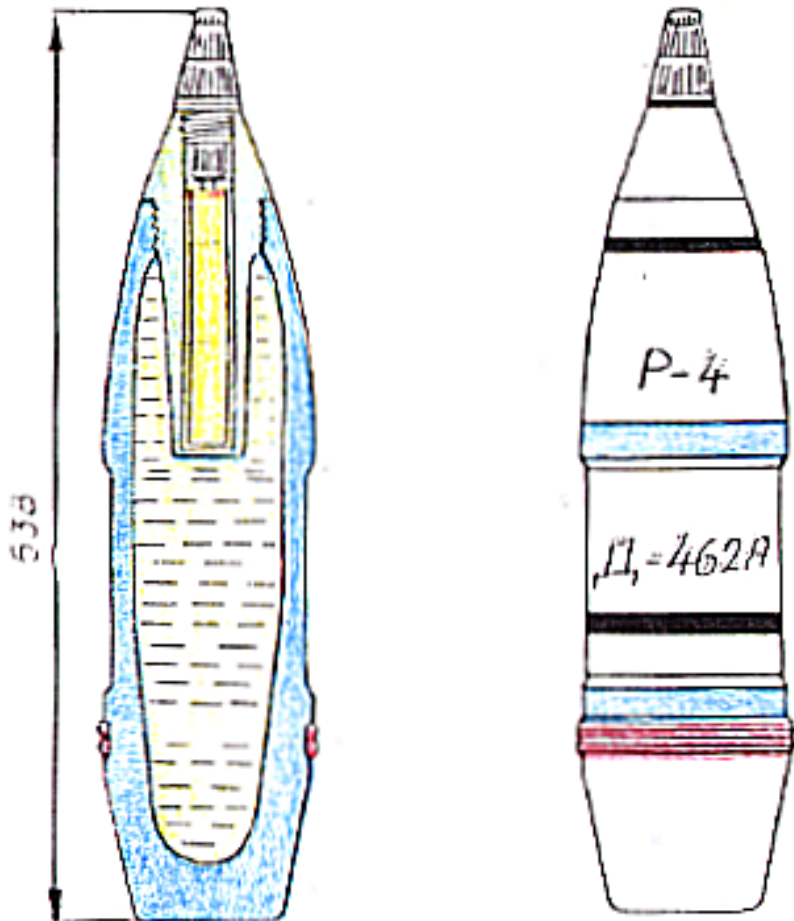

Figure 2-55 Cast-iron smoke shell for 122 mm. howitzer model 54 (38).

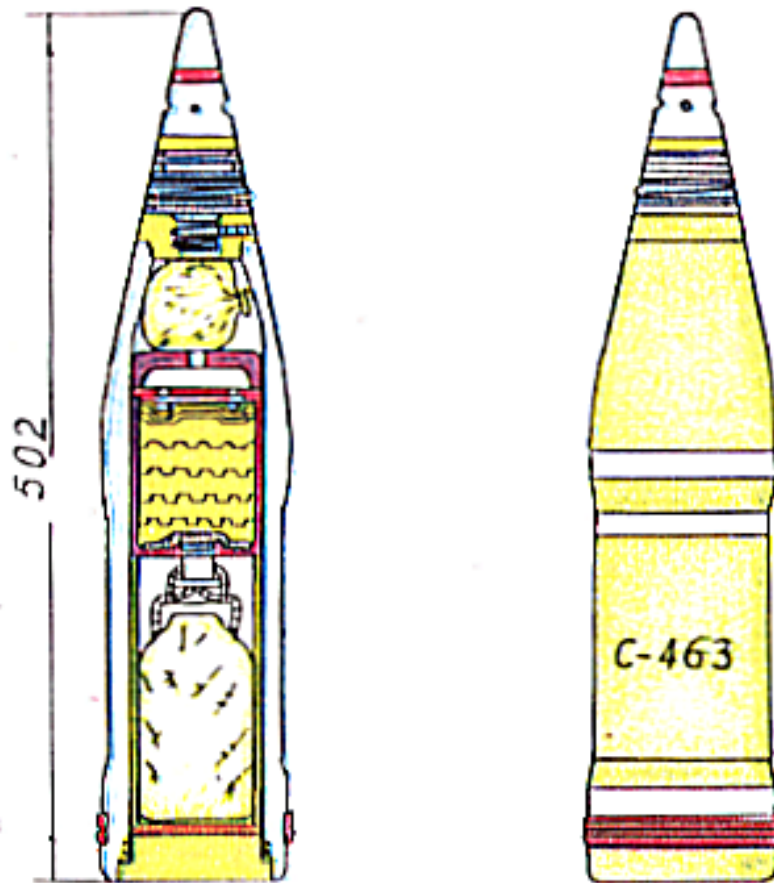

Figure 2-56 Illuminating shell (index No. S-463) for 122 mm. howitzer model 54 (38).

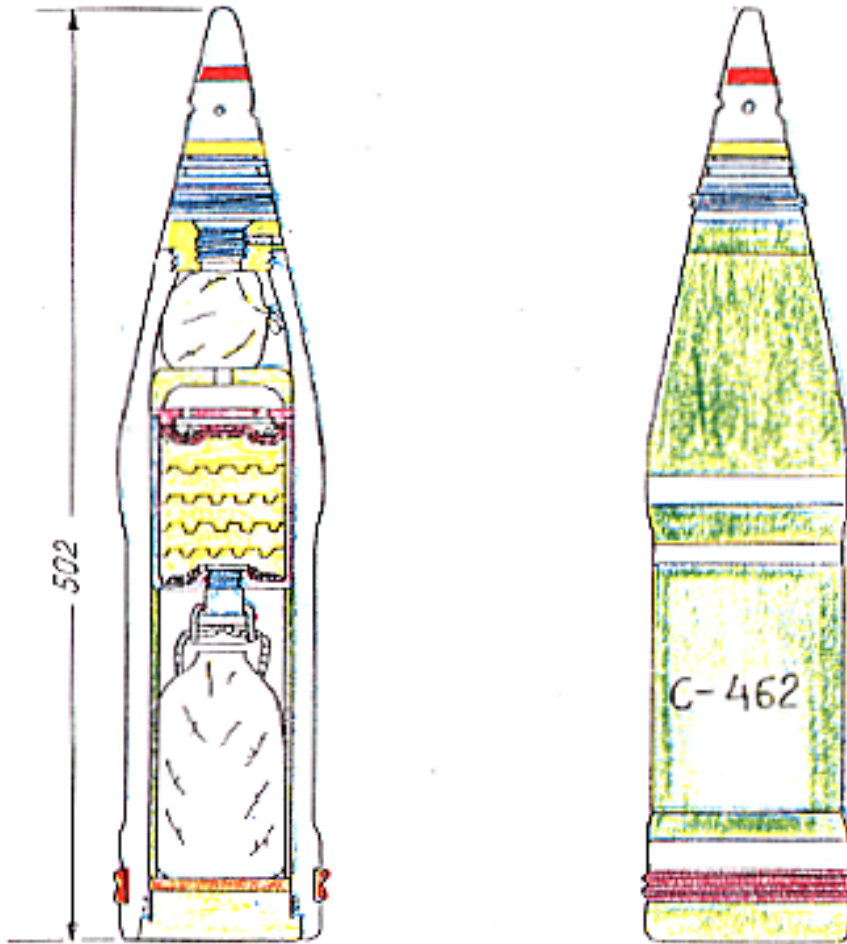

Figure 2-57 Illuminating shell (index No. S-462.) for 122 mm. howitzer model 54 (38).

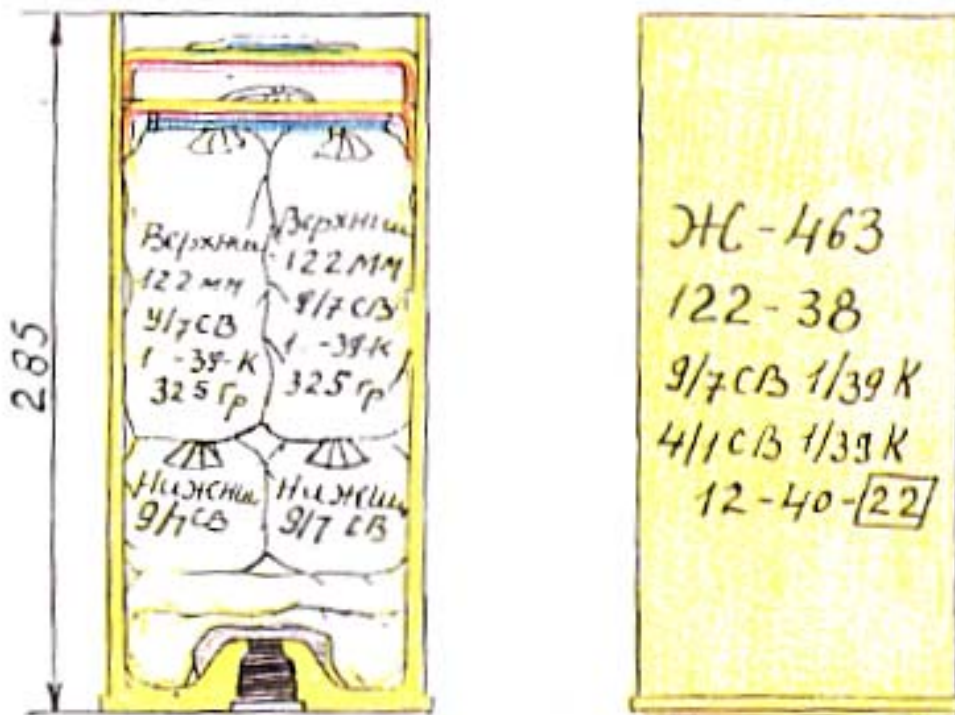

Figure 2-58 Propellant (full charge) for 122 mm. howitzer.

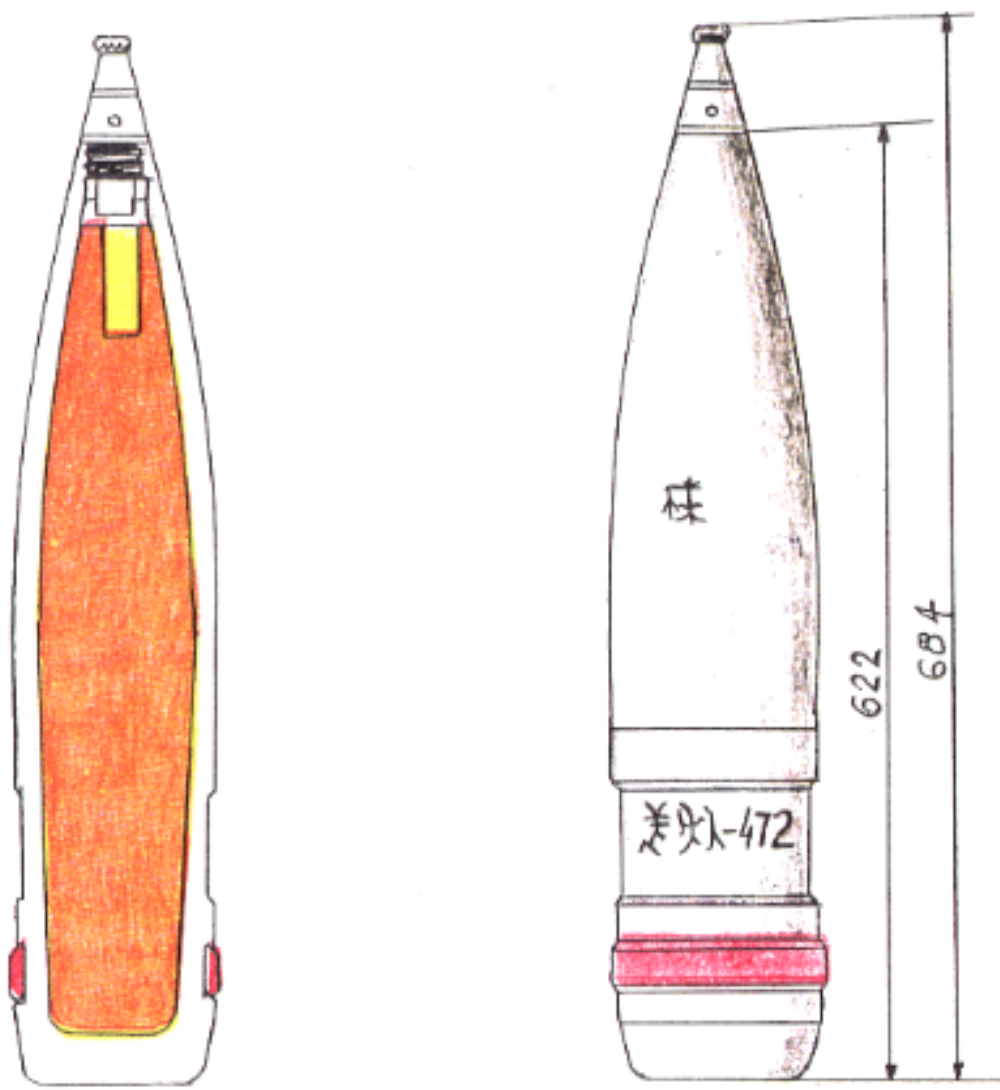

Figure 2-59 HE-fragmentation shell for 122 mm. howitzer 1960 model.

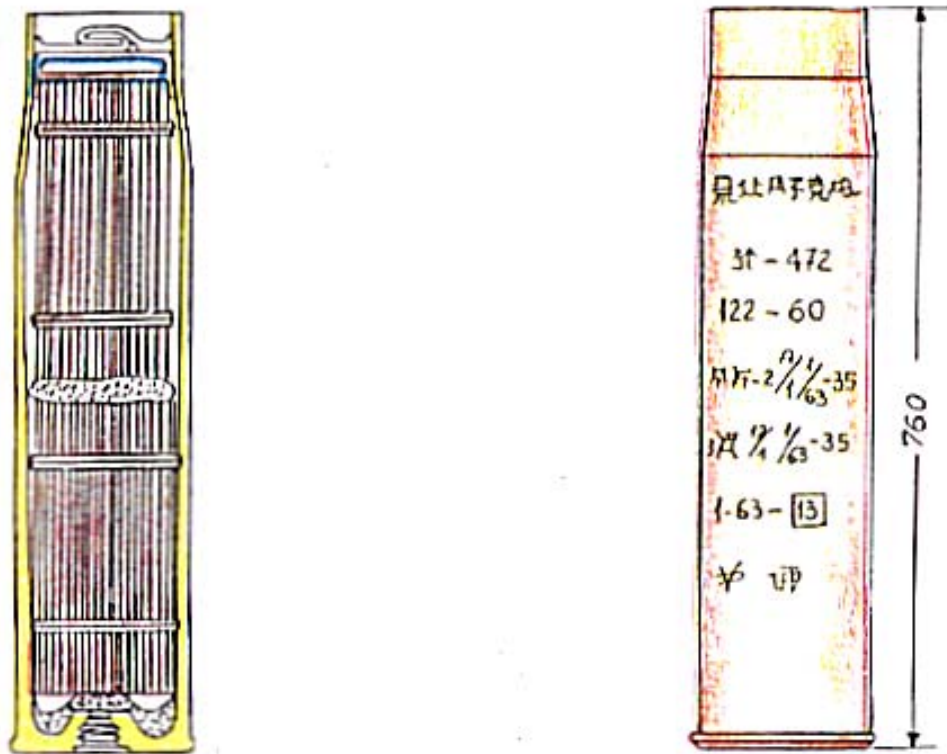

Figure 2-60 Propellant (full charge) for 122 mm. howitzer 1960 model.

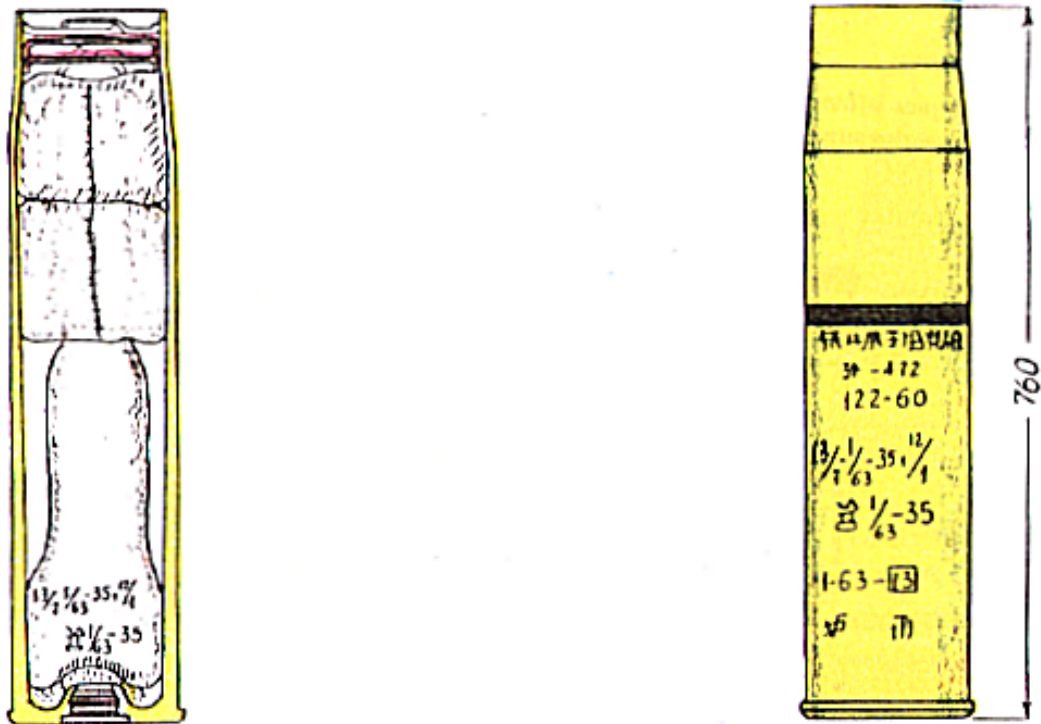

Figure 2-61 Propellant (reduced charge) for 122 mm. howitzer 1960 model.

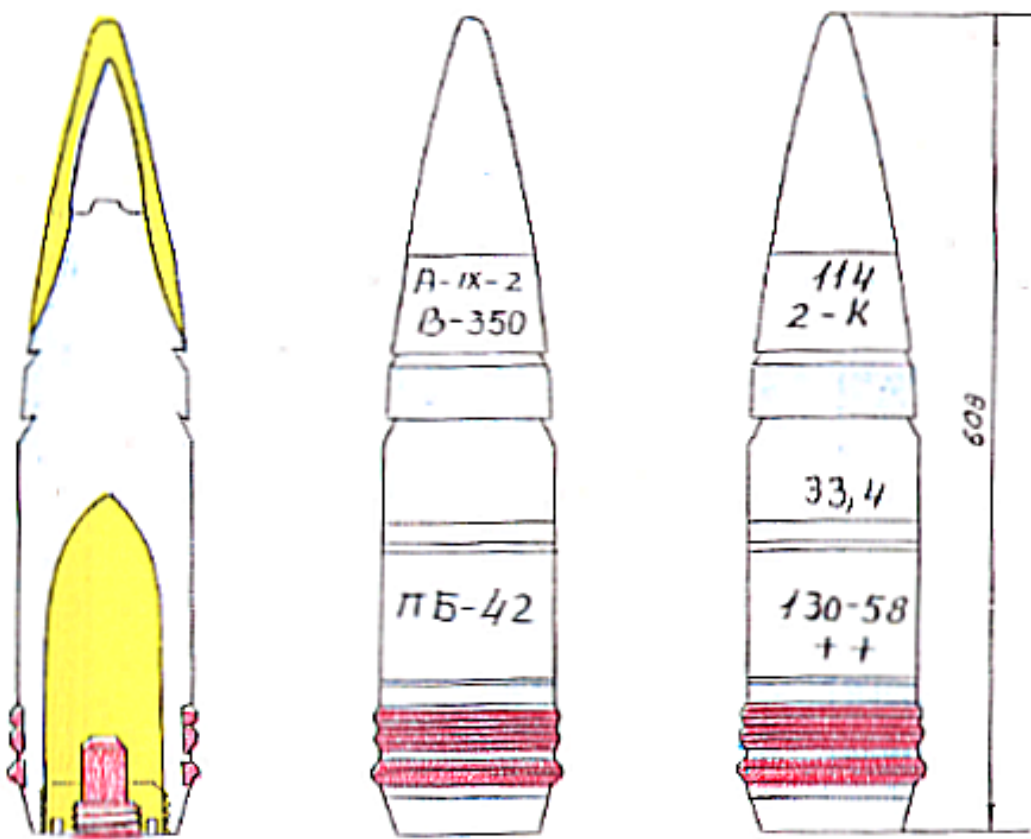

Figure 2-62 Semi-AP shell for 130 mm. coastal artillery gun (mechanical extraction.)

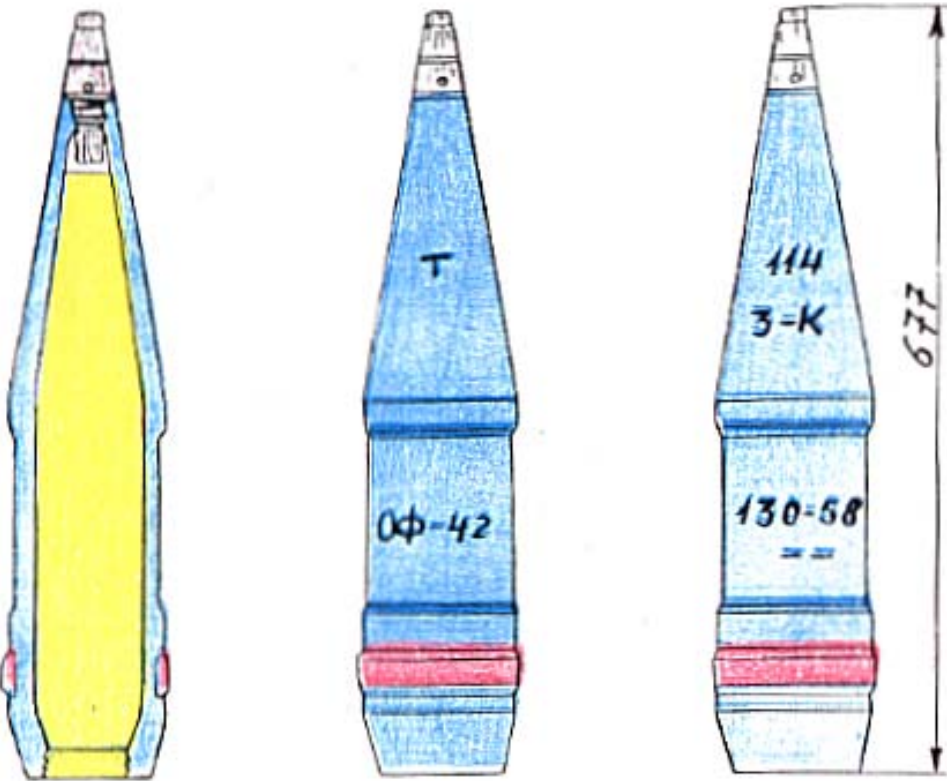

Figure 2-63 HE-fragmentation shell for 130 mm. coastal artillery gun (mechanical extraction.)

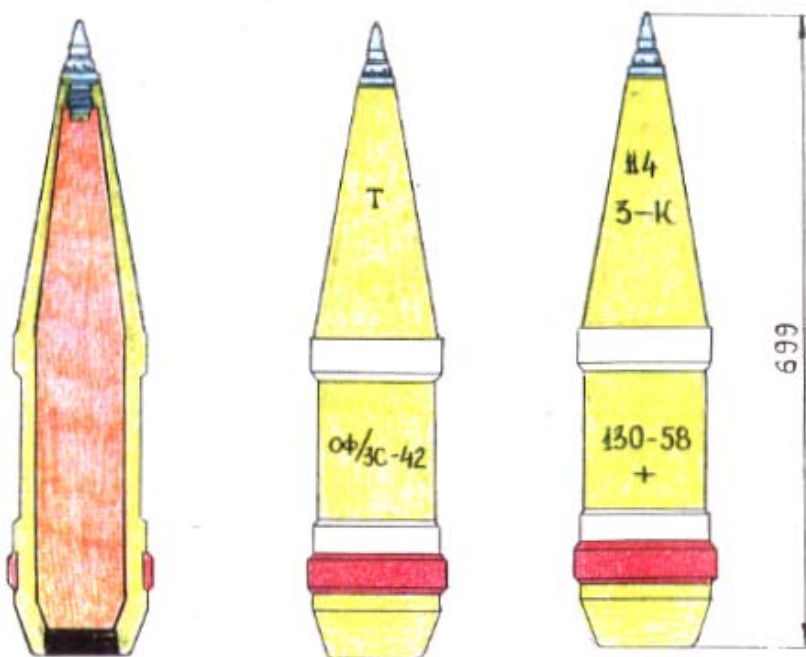

Figure 2-64 Fragmentation airburst (AA) shell for 130 mm coastal artillery gun (mechanical extraction.)

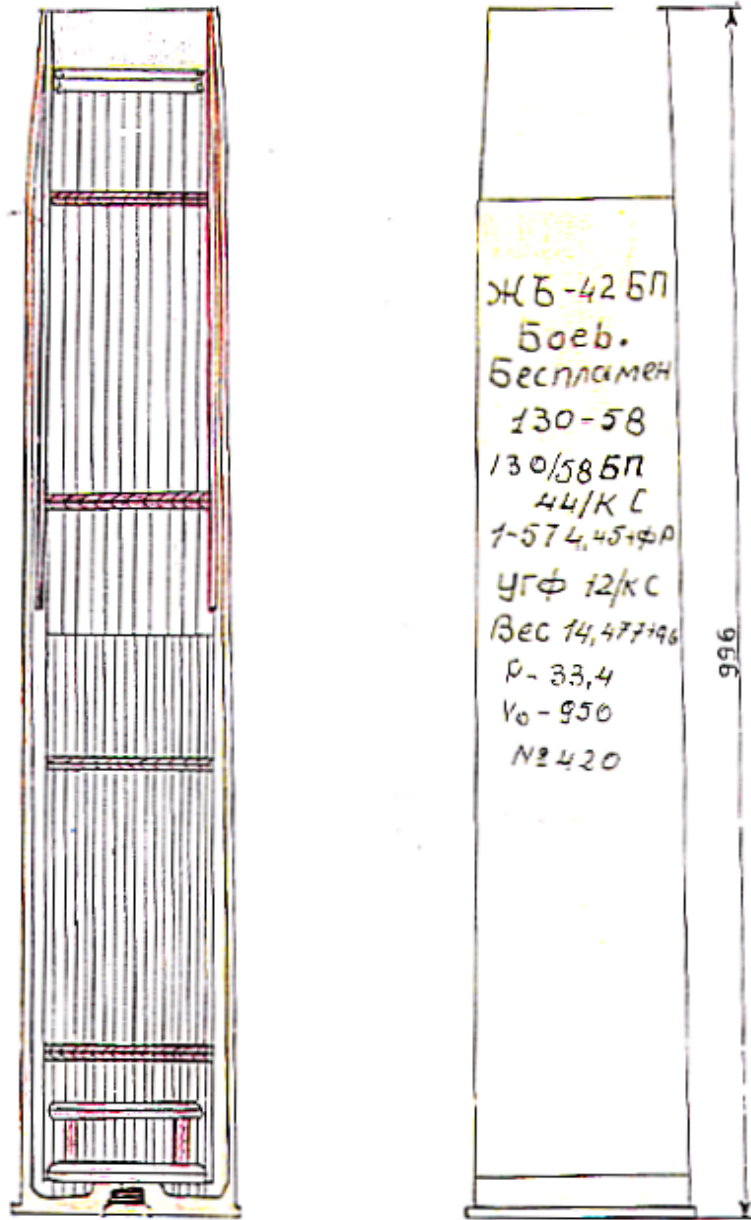

Figure 2-65 Propellant (full charge) for 130 mm. coastal artillery gun (mechanical extraction.)

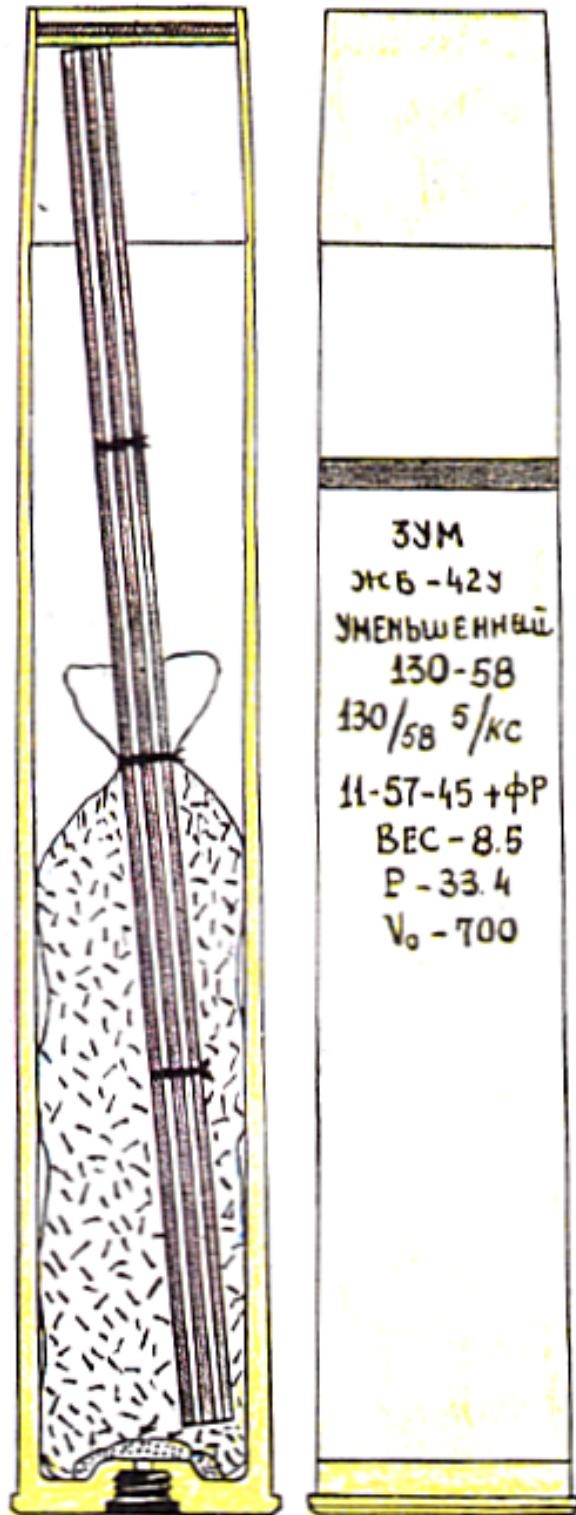

Figure 2-66 Propellant (reduced charge) for 130 mm coastal artillery gun (mechanical extraction.)

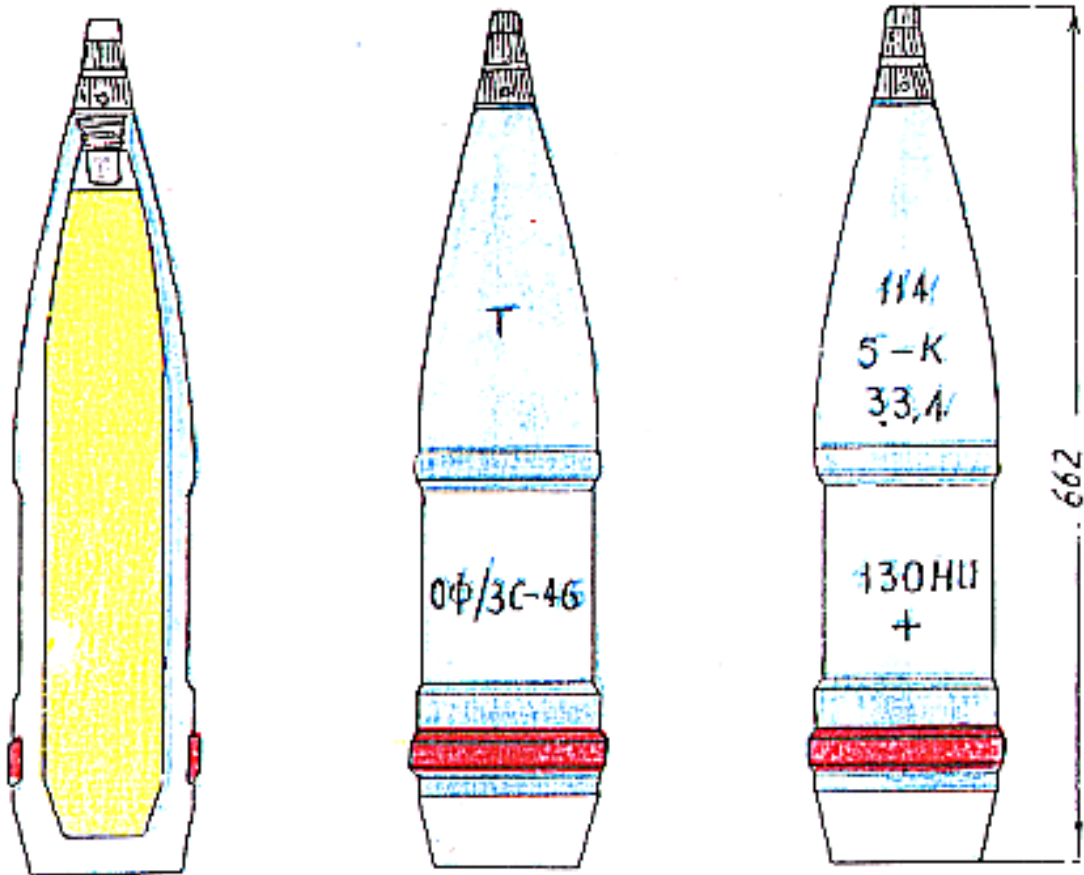

Figure 2-67 HE-fragmentation shell for 130 mm. coastal artillery gun (separate loading.)

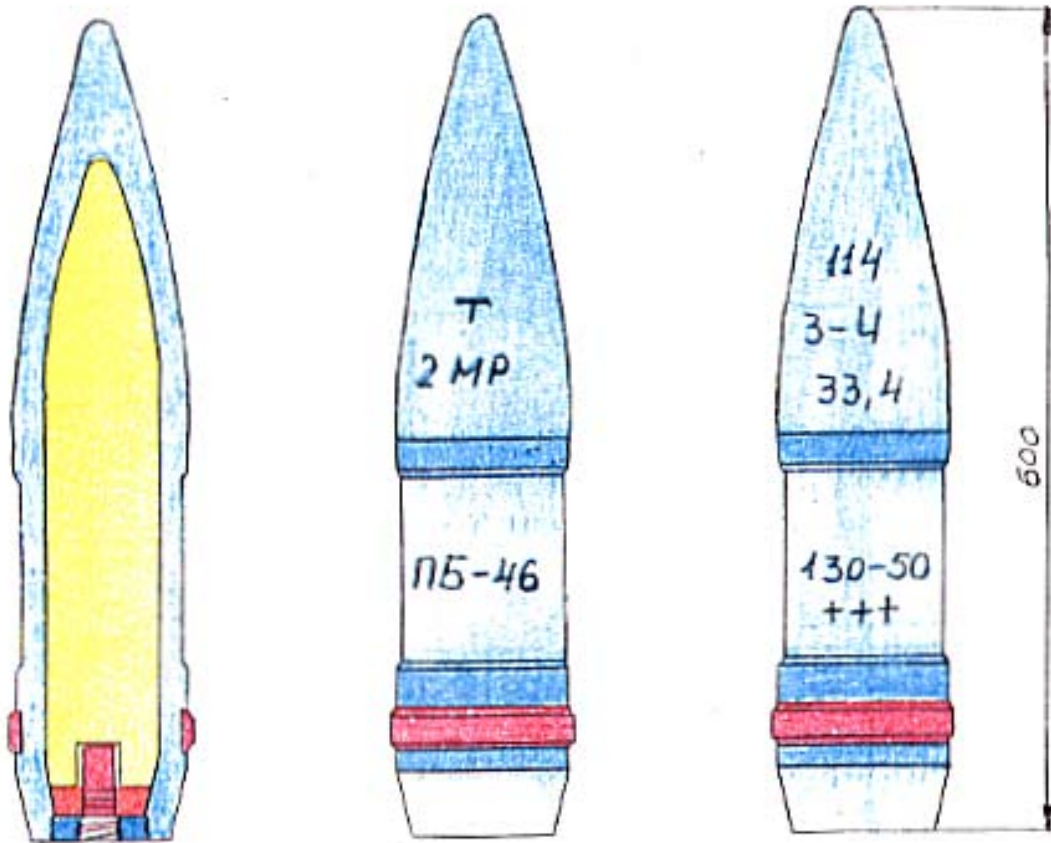

Figure 2-68 Semi-AP shell for 130 mm. coastal artillery gun (separate loading.)

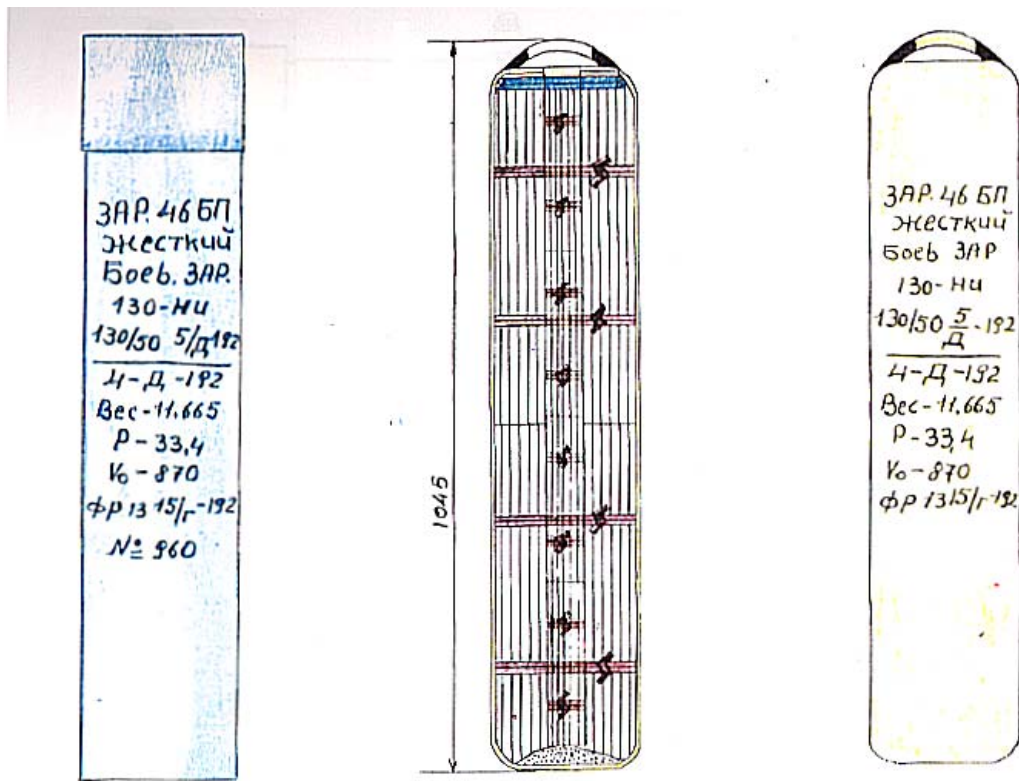

Figure 2-69 Propellant (full charge) for 130 mm. coastal artillery gun (separate loading.)

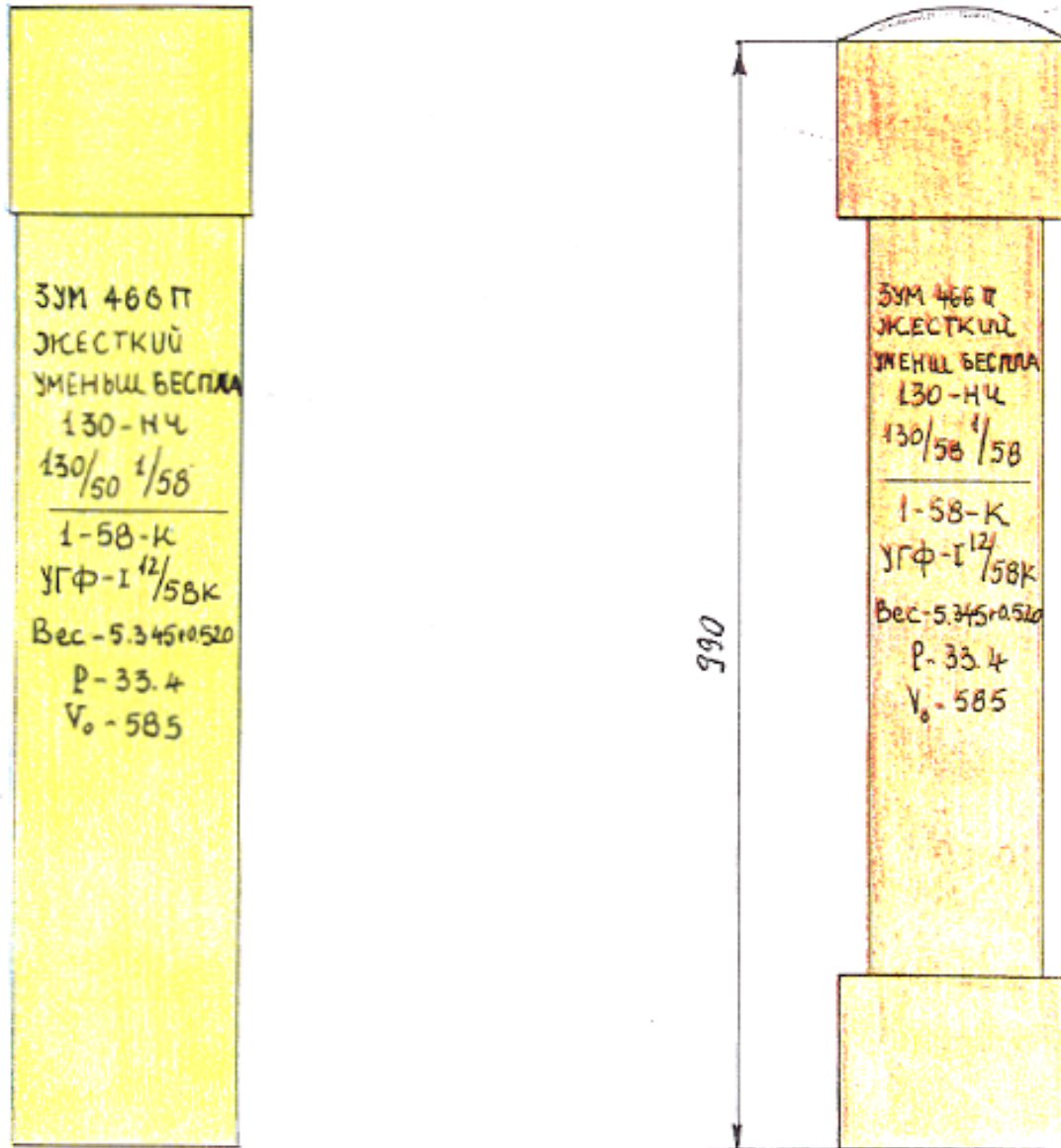

Figure 2-70 Propellant (reduced charge) for 130 mm. coastal artillery gun (separate loading.)

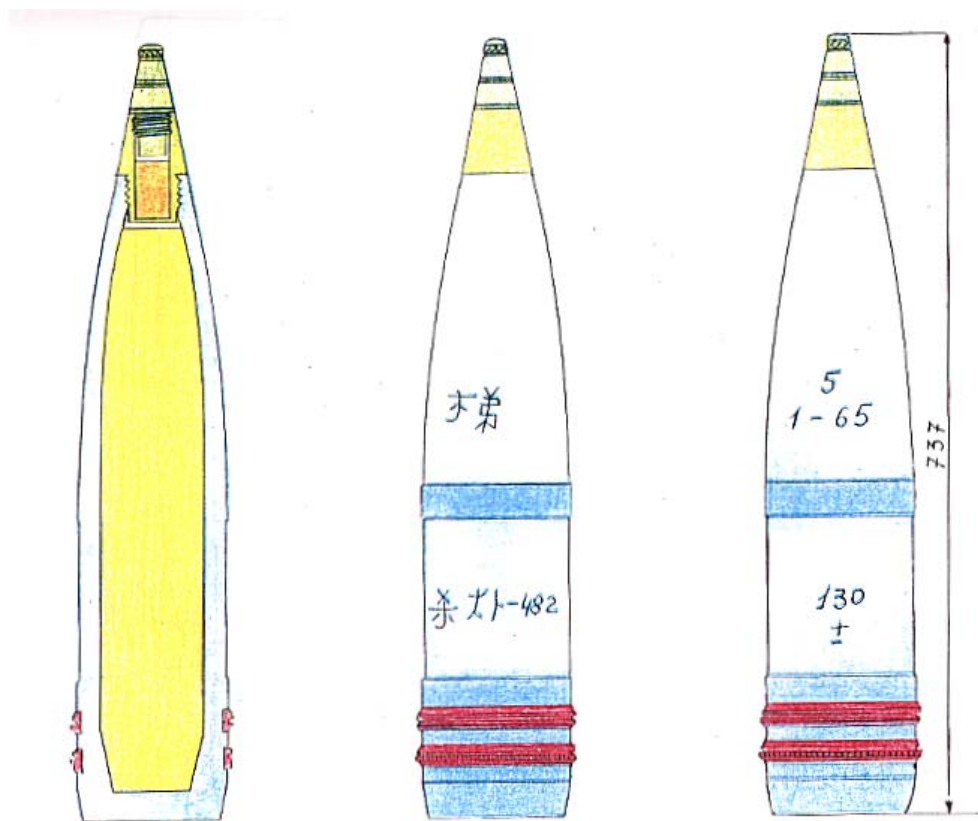

Figure 2-71 HE-fragmentation shell for 130 mm. field gun model 1959.

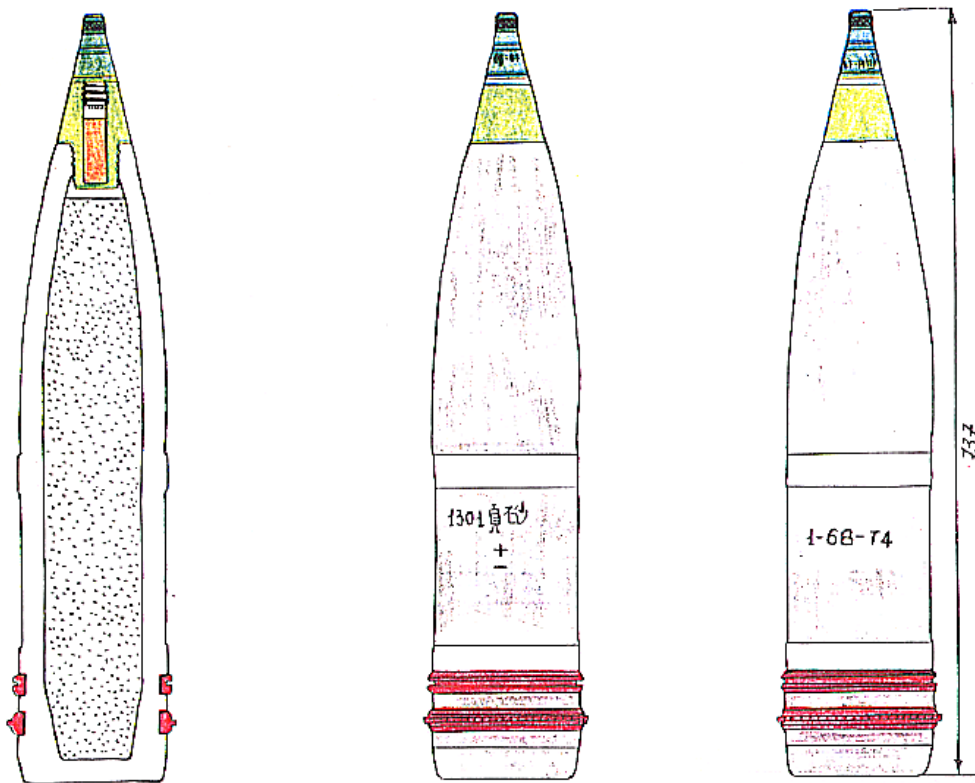

Figure 2-72 Practice shell for 130 mm. field gun model 1959.

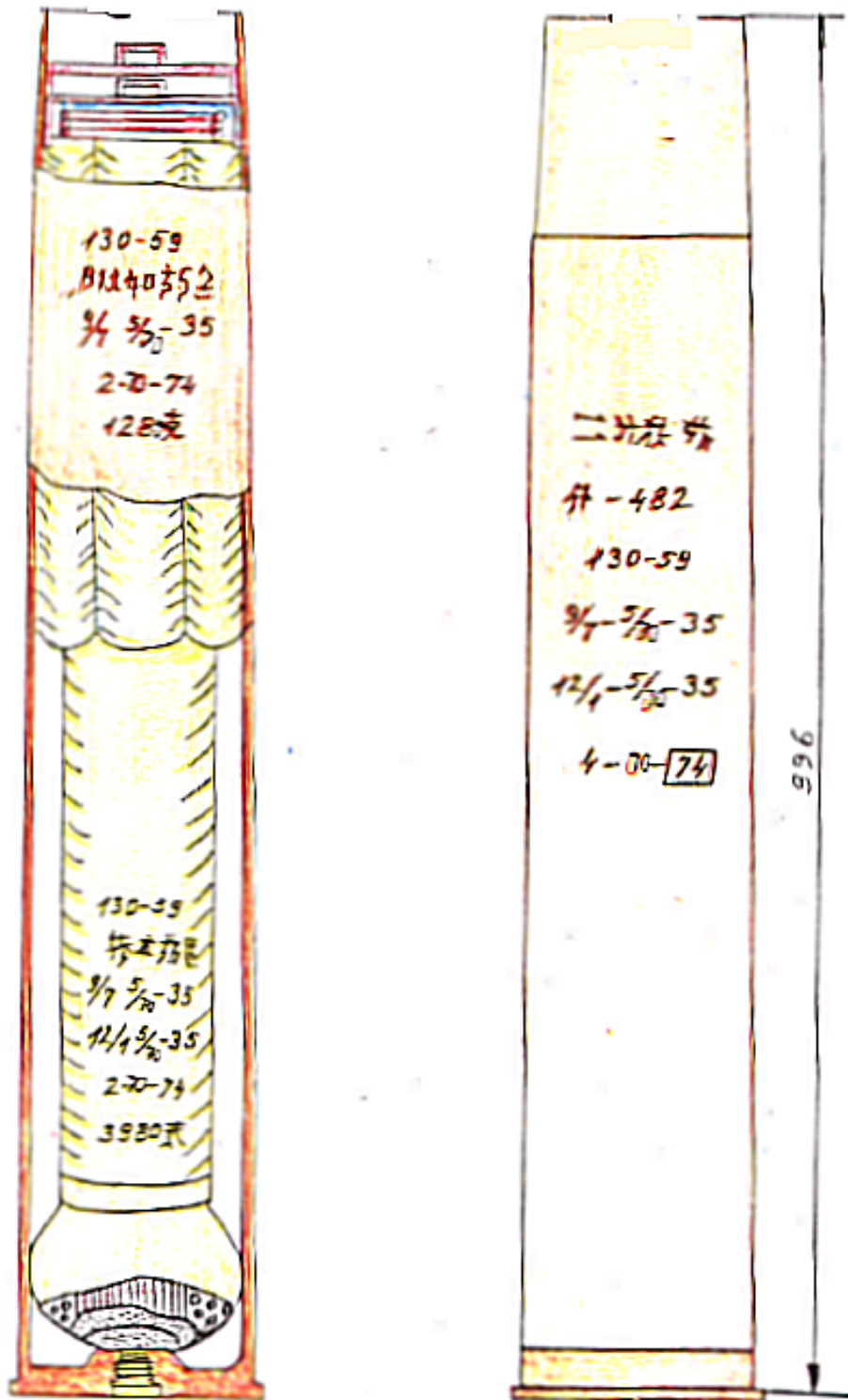

Figure 2-73 Propellant (reduced charge) for 130 mm. field gun model 1959.

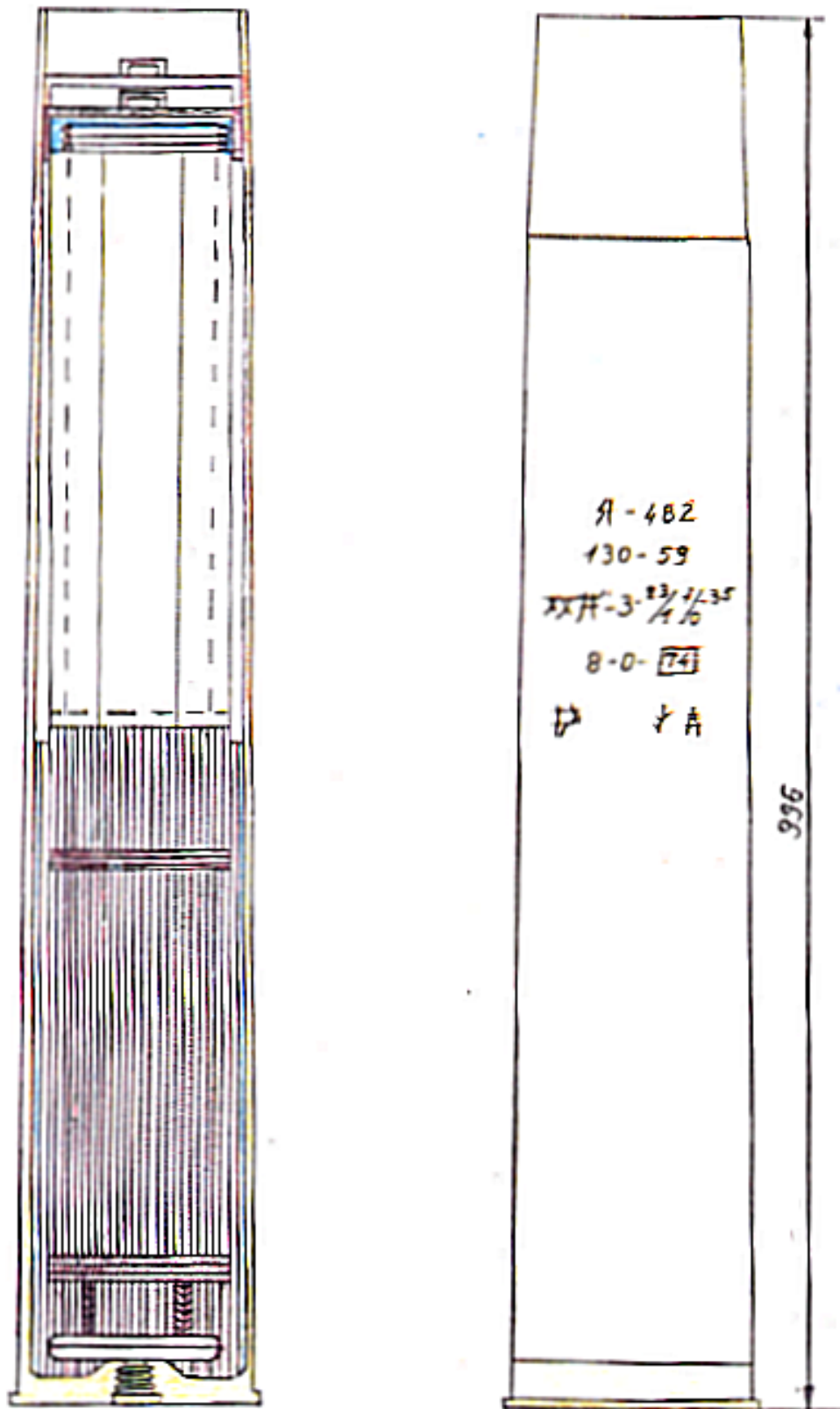

Figure 2-74 Propellant (full charge) for 130 mm. field gun model 1959.

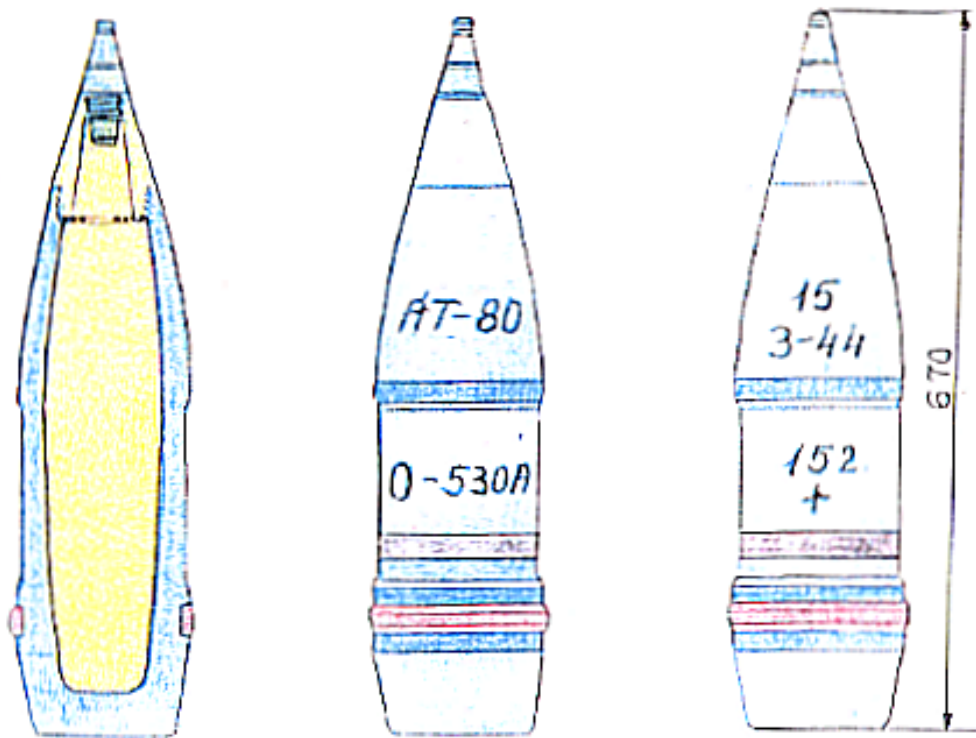

Figure 2-75 Steel HE-fragmentation shell for 152 mm. howitzer.

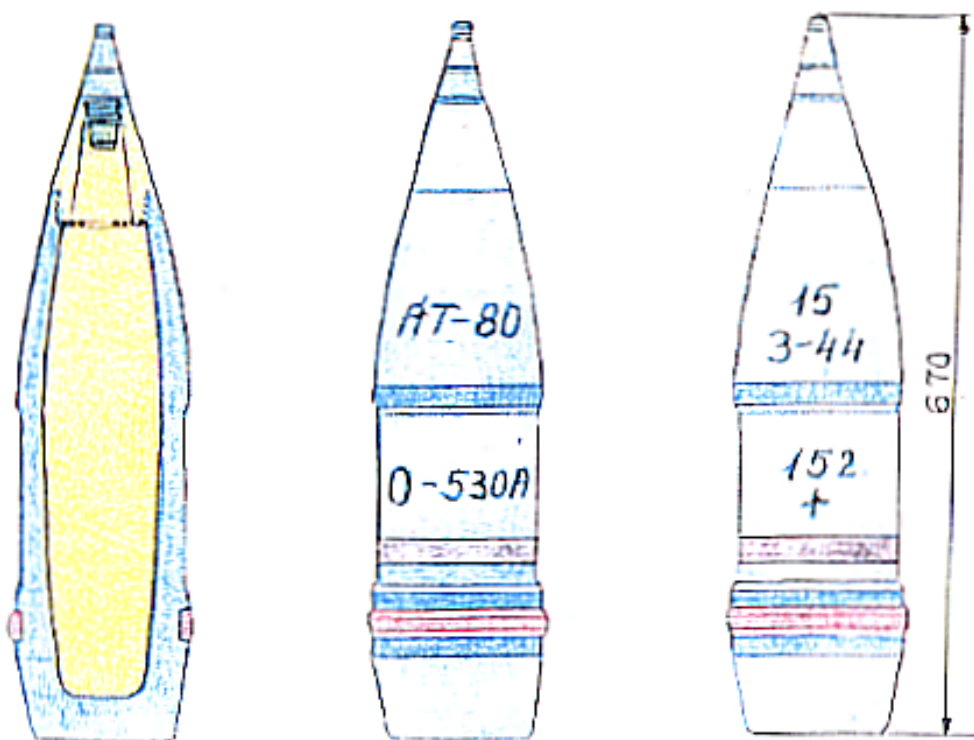

Figure 2-76 Cast-iron fragmentation shell for 152 mm. howitzer.

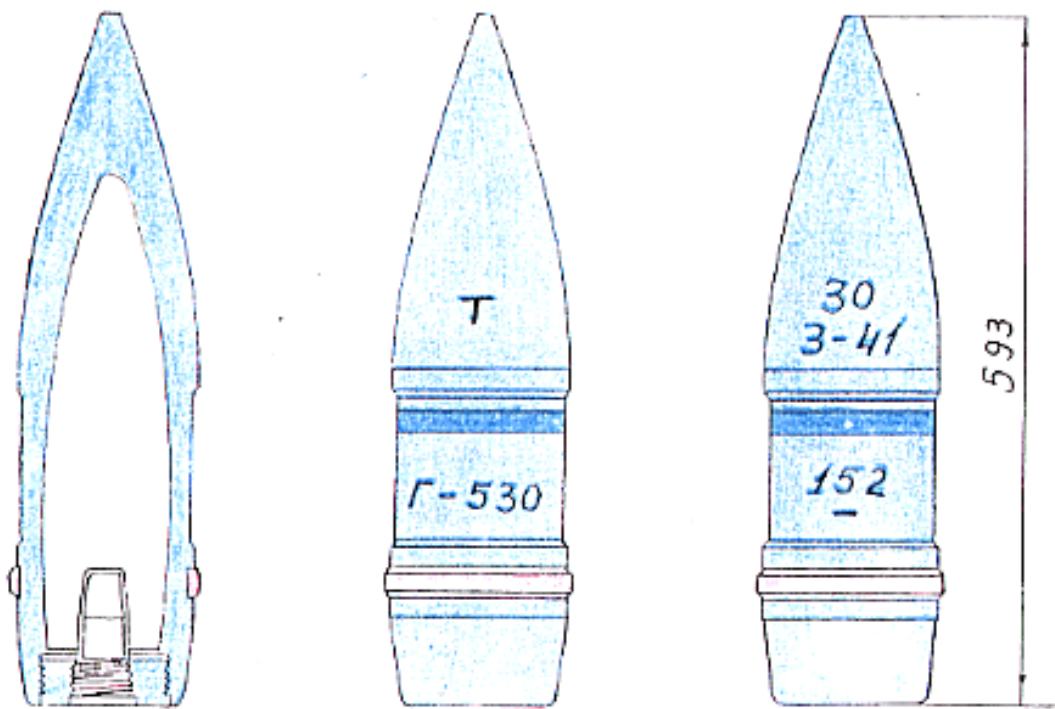

Figure 2-77 Concrete-piercing shell for 152 mm. howitzer.

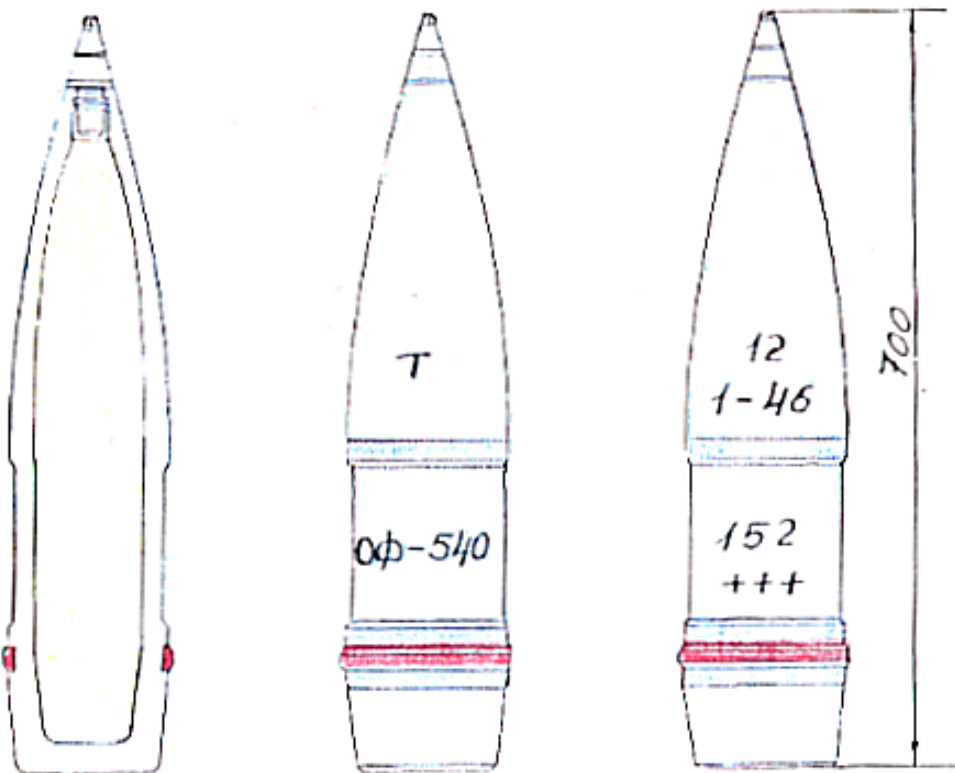

Figure 2-78 HE-fragmentation shell for 152 mm. gun-howitzer.

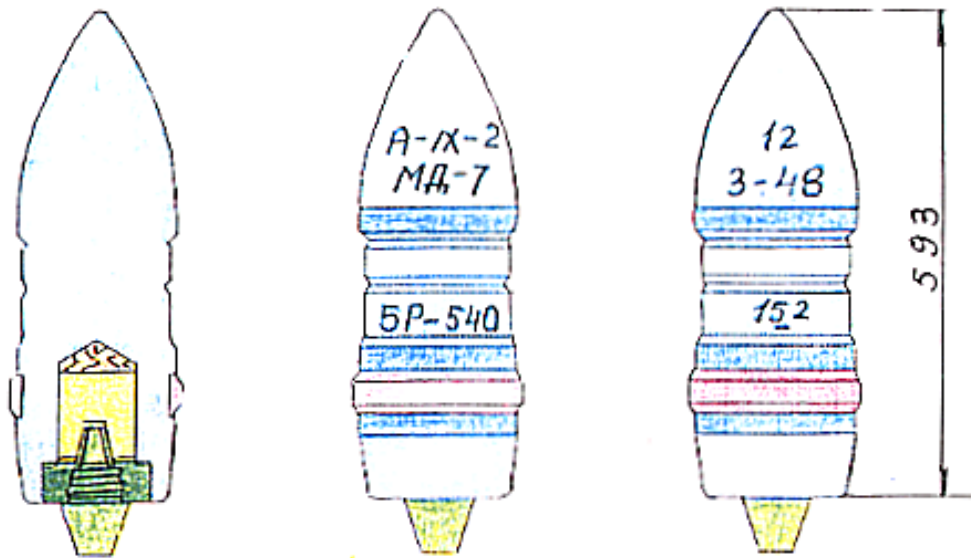

Figure 2-79 AP shell for 152 mm. gun-howitzer.

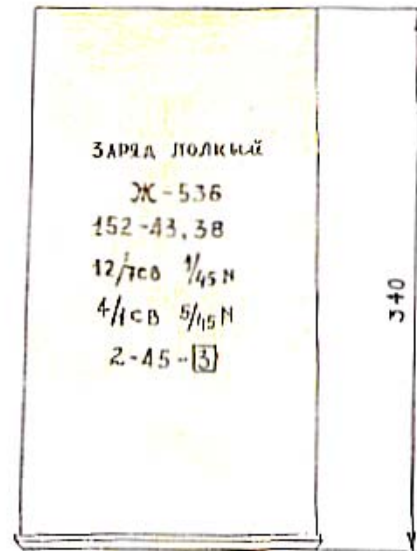
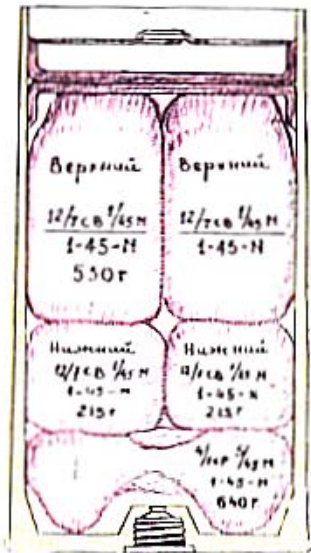

Figure 2-80 Propellant (full charge) for 152 mm. howitzer.

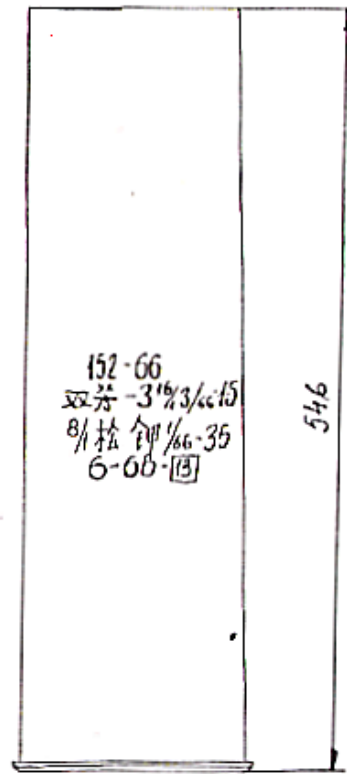
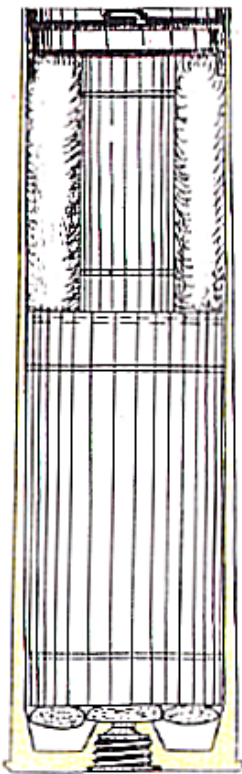

Figure 2-81 Propellant (full charge) for 152 mm. gun-howitzer model 1966.

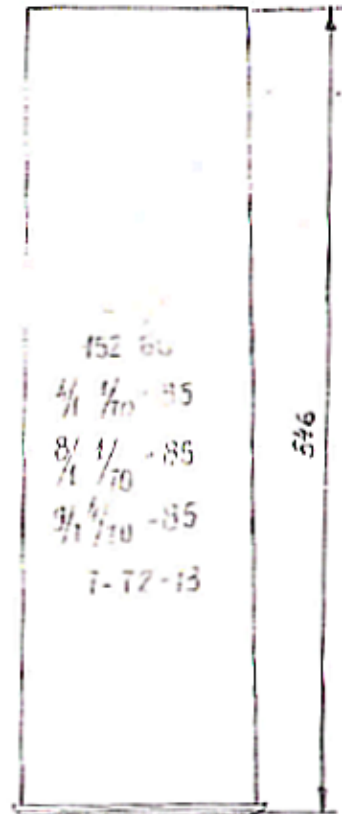
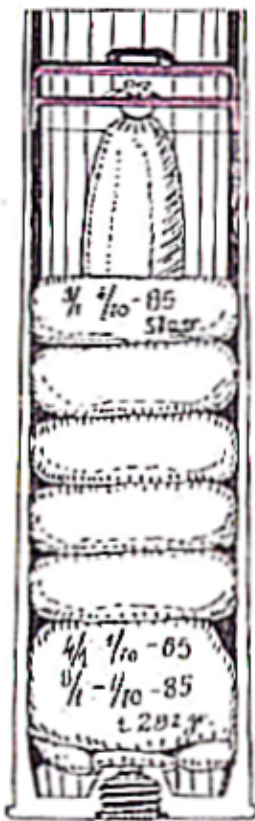

Figure 2-82 Propellant (Charge no. 2) for 152 mm. gun-howitzer model 1966.

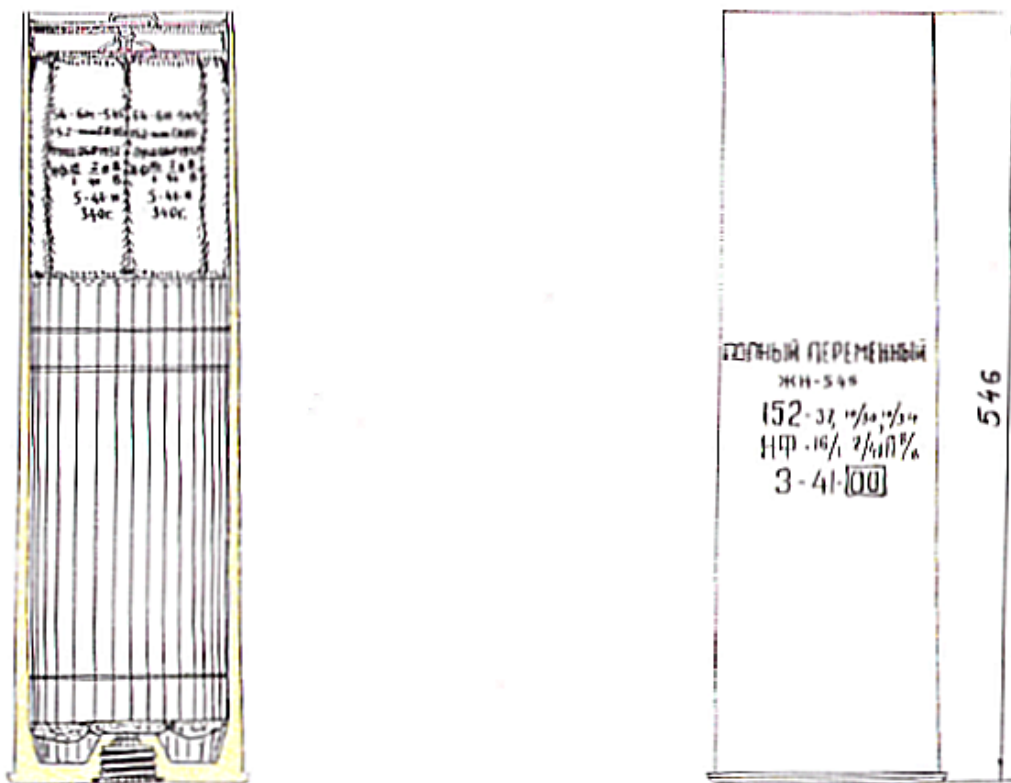

Figure 2-84 Propellant (full charge) (Index No. ZHN-545) for 152 mm. gun-howitzer model 1937.

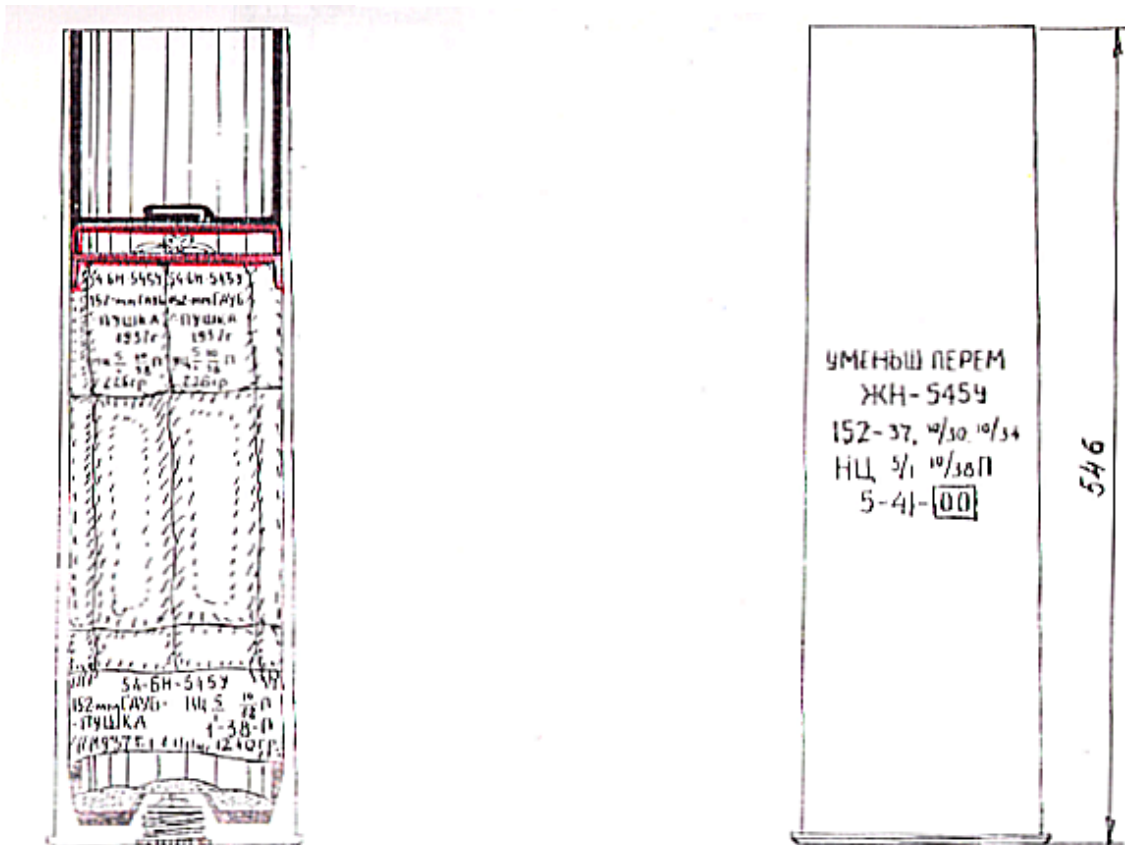

Figure 2-85 Propellant (reduced charge) (Index No. Zh-545U) for 152 mm. gun-howitzer model 1937.

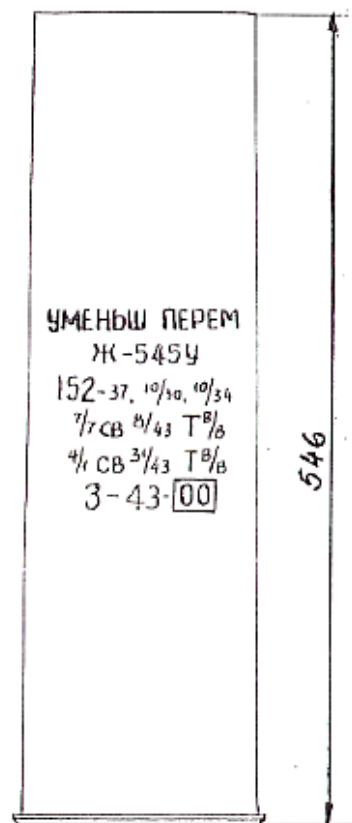
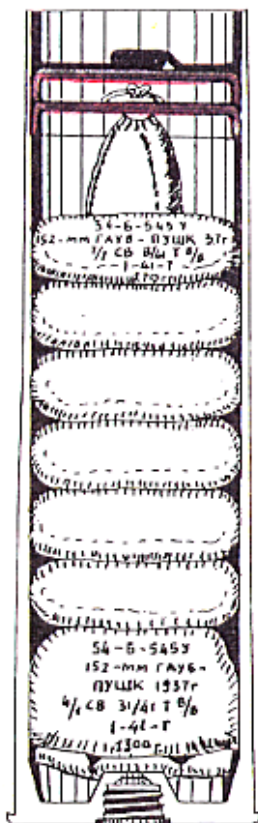

Figure 2-86 Propellant (reduced charge) (Index No. ZhN-545U) for 152 mm. gun-howitzer model 1937.

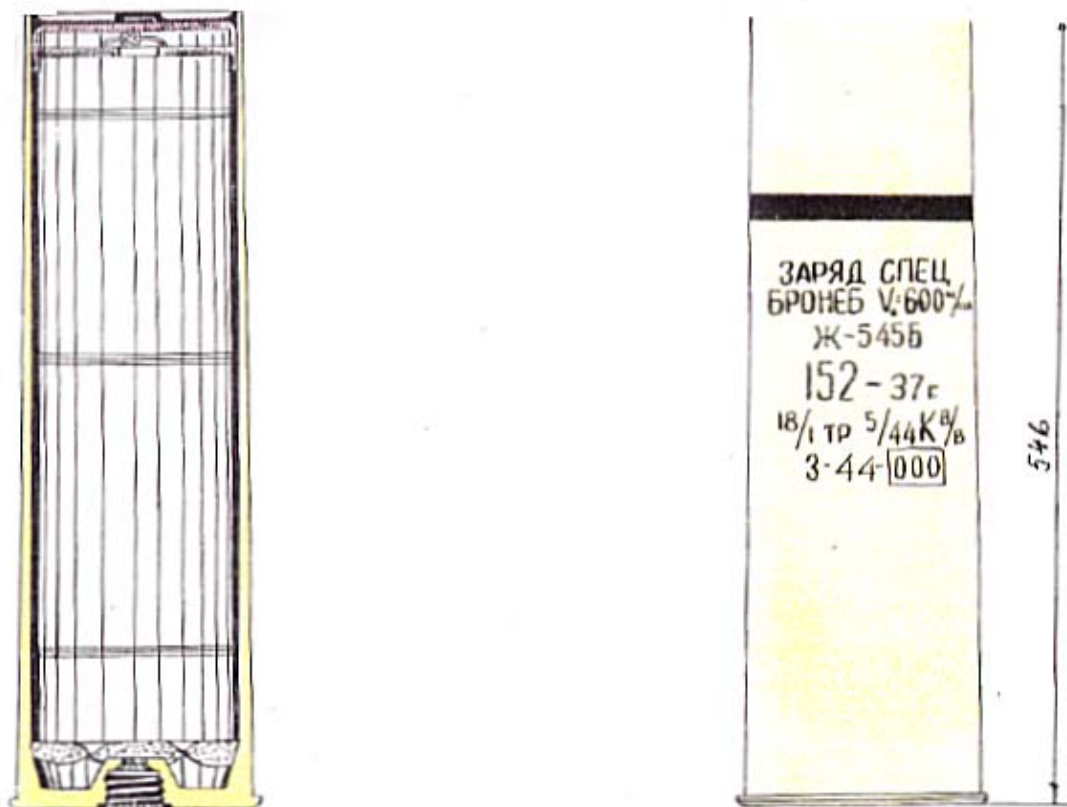

Figure 2-87 Propellant (special charge) for 152 mm. gun-howitzer model 1937.

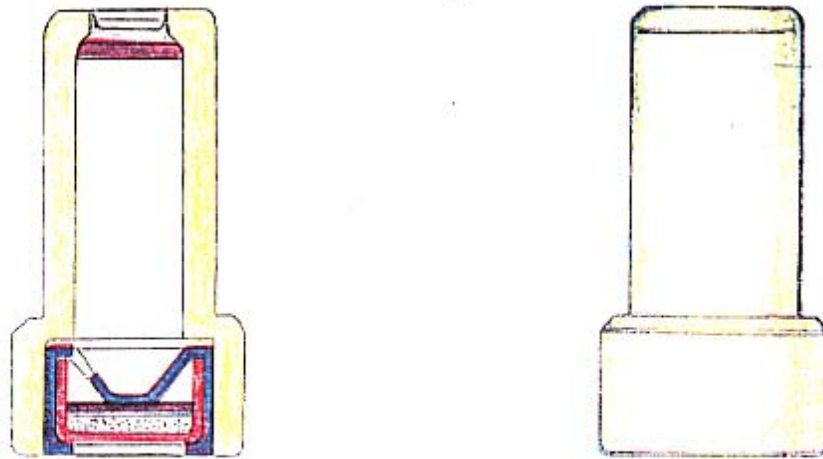

Figure 2-88 ZTN primer.

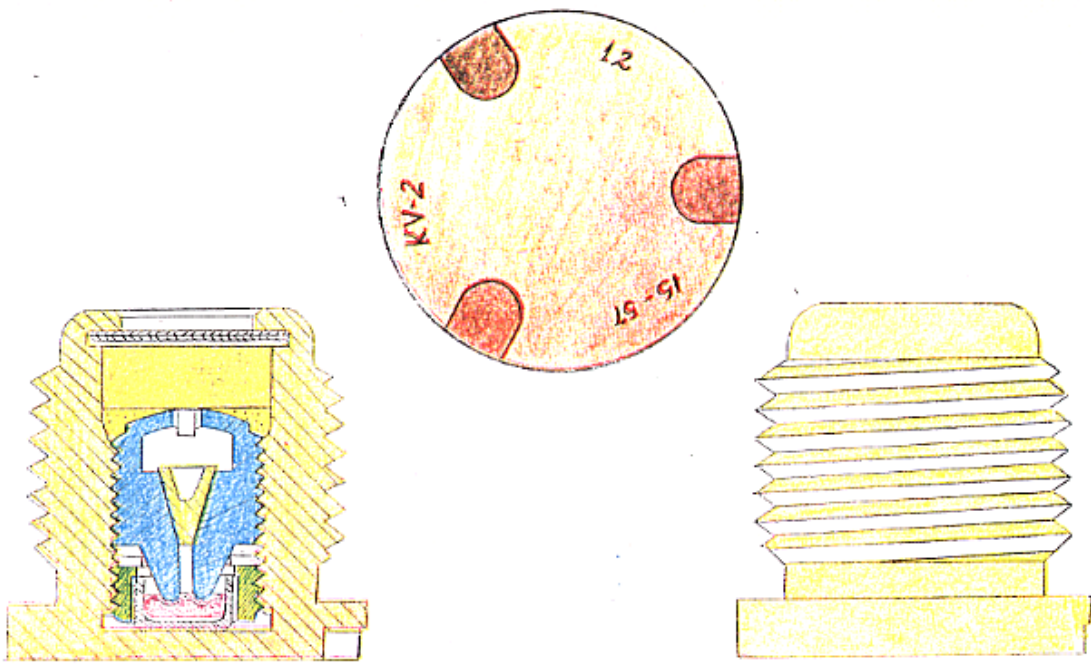

Figure 2-89 KV-2 primer.

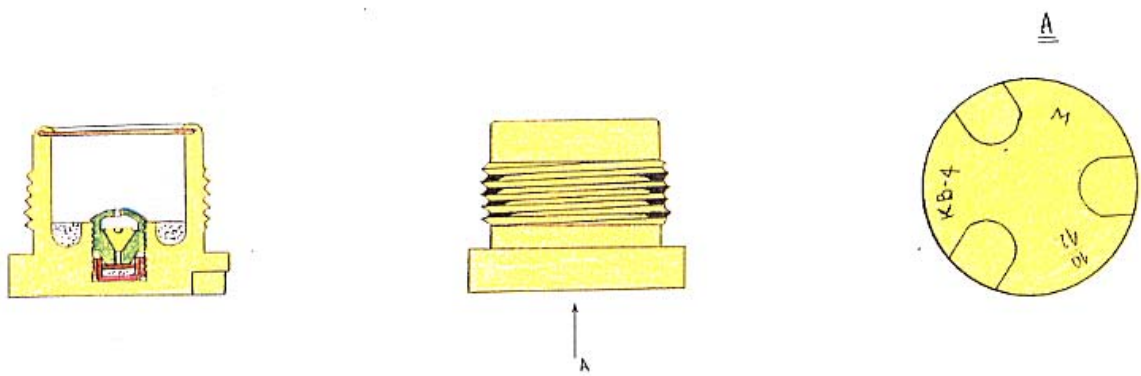

Figure 2-90 KV-4 primer

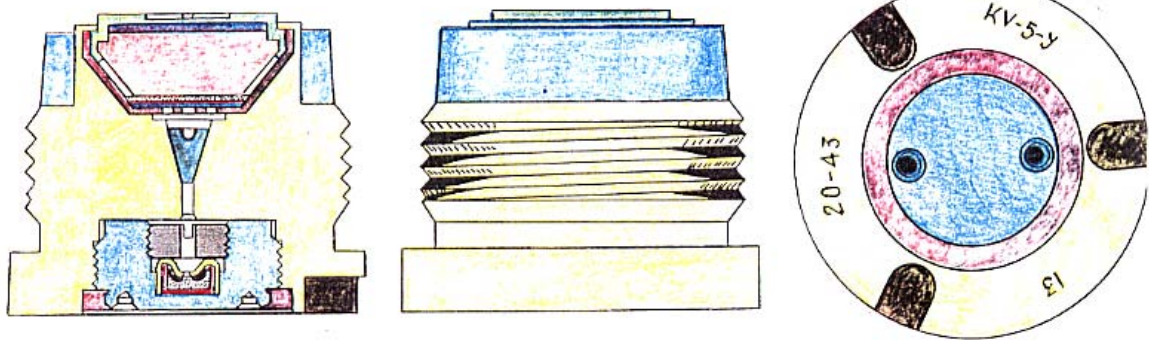

Figure 2-91 KV-5 primer.

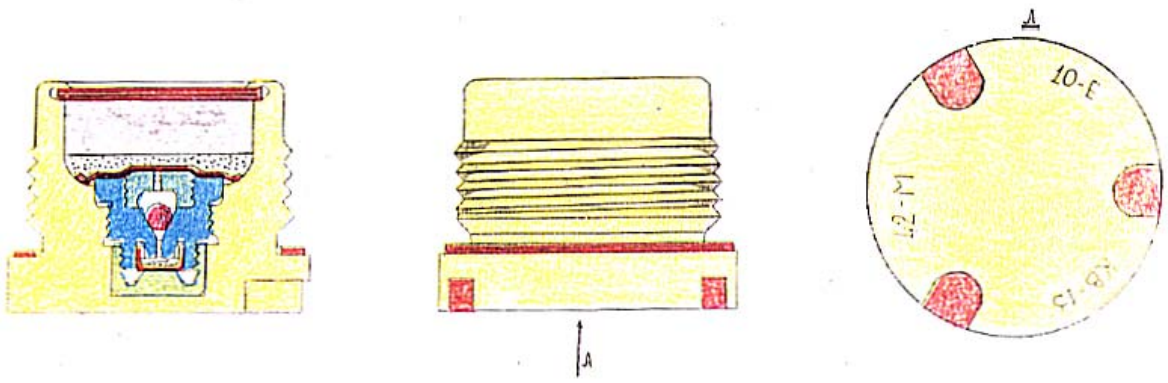

Figure 2-92 KV-13 primer.

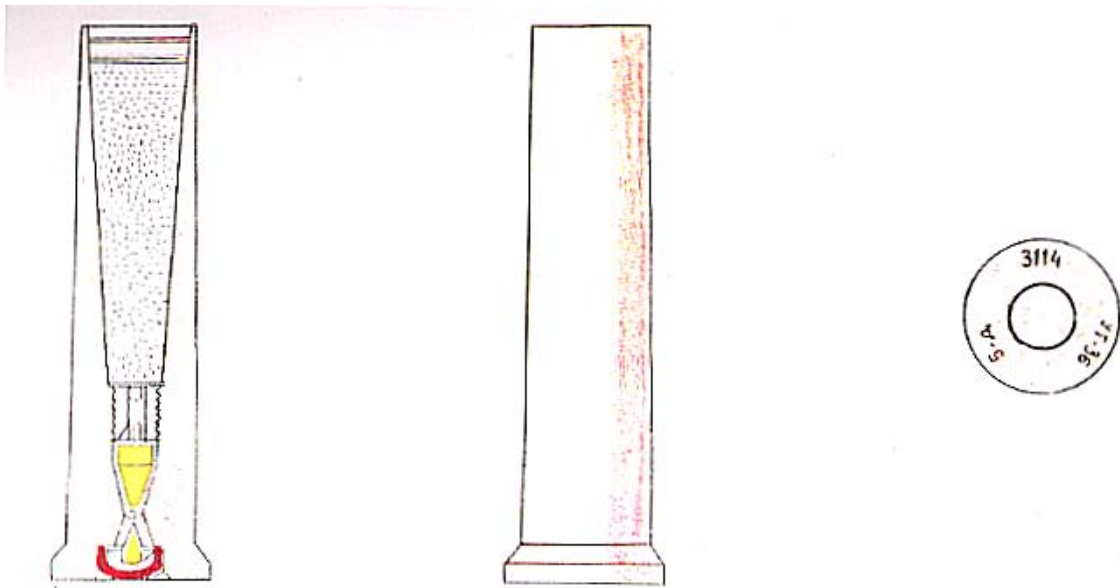

Figure 2-93 UT-36 mechanical primer for charges used in 130 mm. coastal artillery gun (separate loading.)

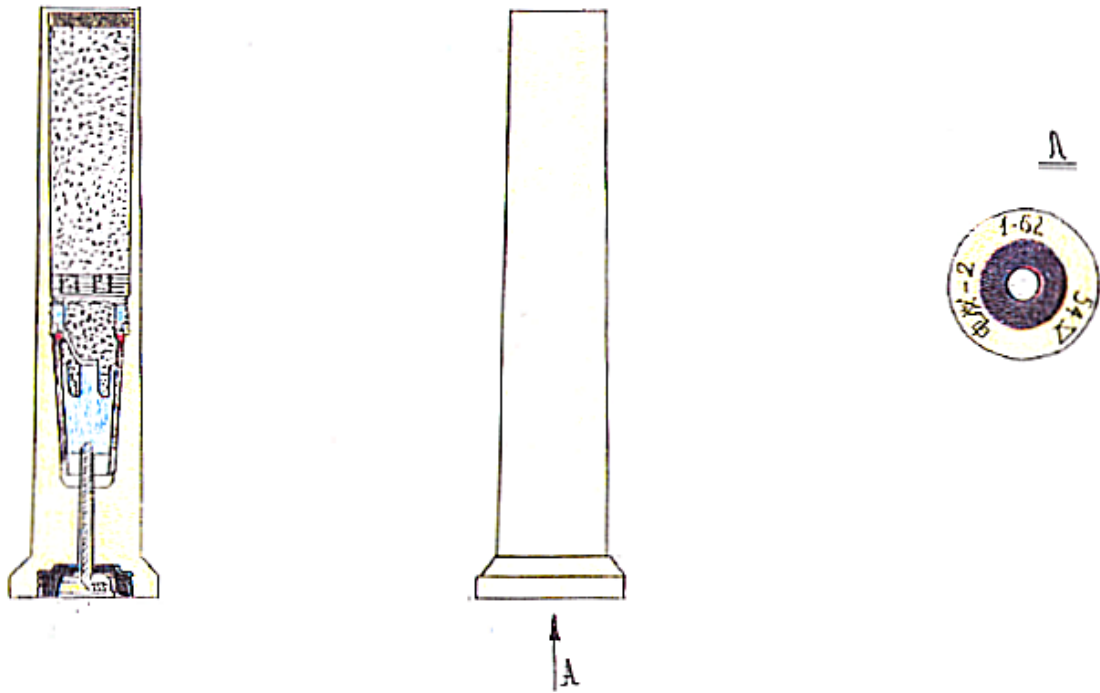

Figure 2-94 GT-2 electrical primer for charges used in 130 mm. coastal artillery gun (separate loading.)

PART III

DRAWINGS OF MUNITIONS FOR RECOILLESS GUNS

Presumably Page 256 is blank, since the next numbered page is 257.[IN ORIGINAL]

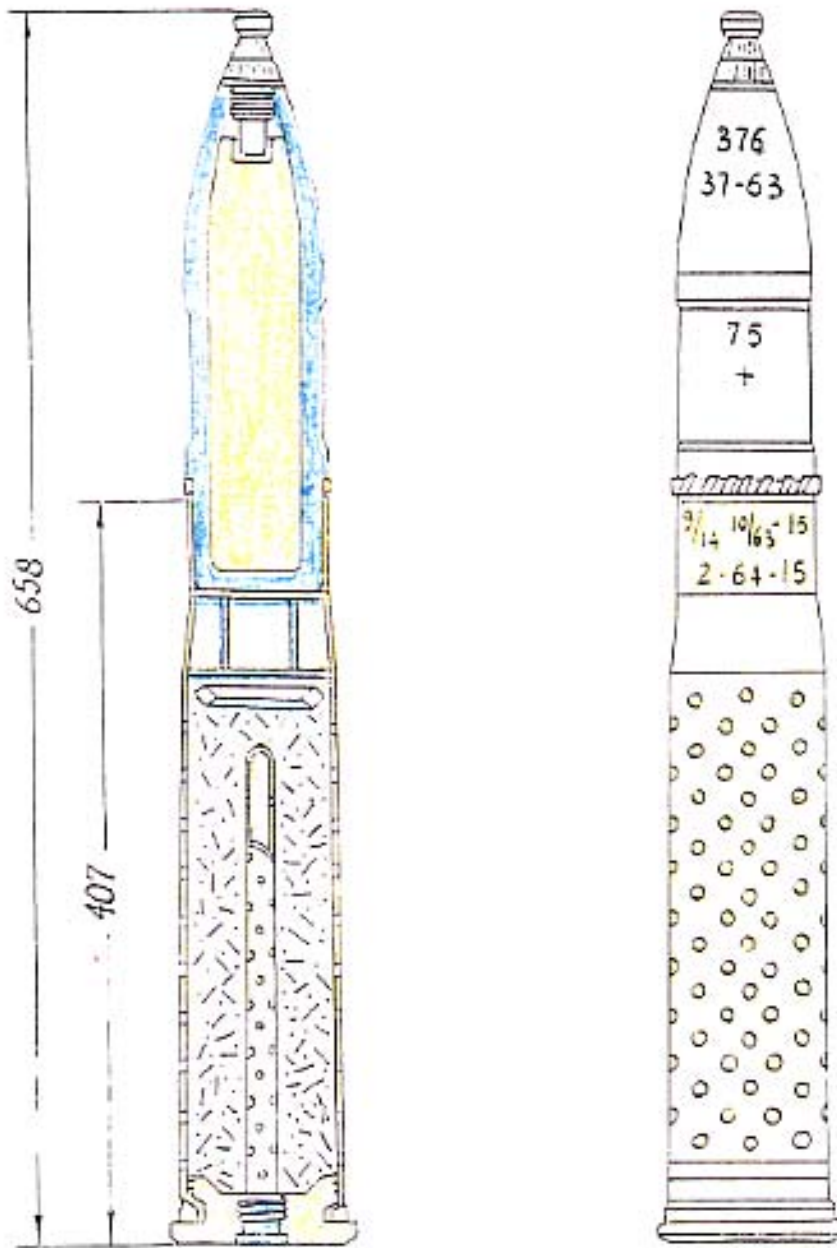

Figure 3-1 75 mm. recoilless gun round with fragmentation shell.

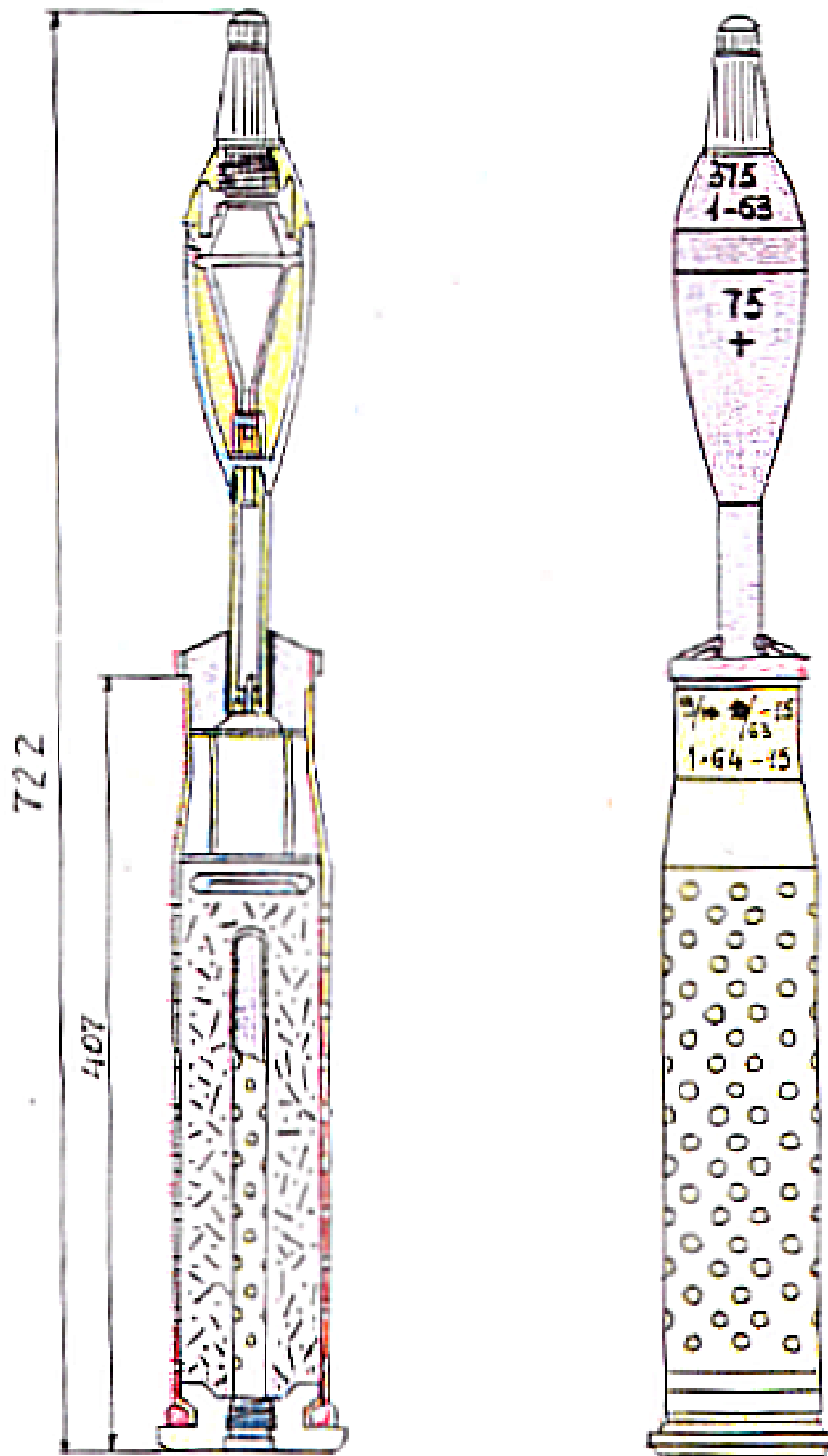

Figure 3-2 75 mm. recoilless gun round with shaped charge shell.

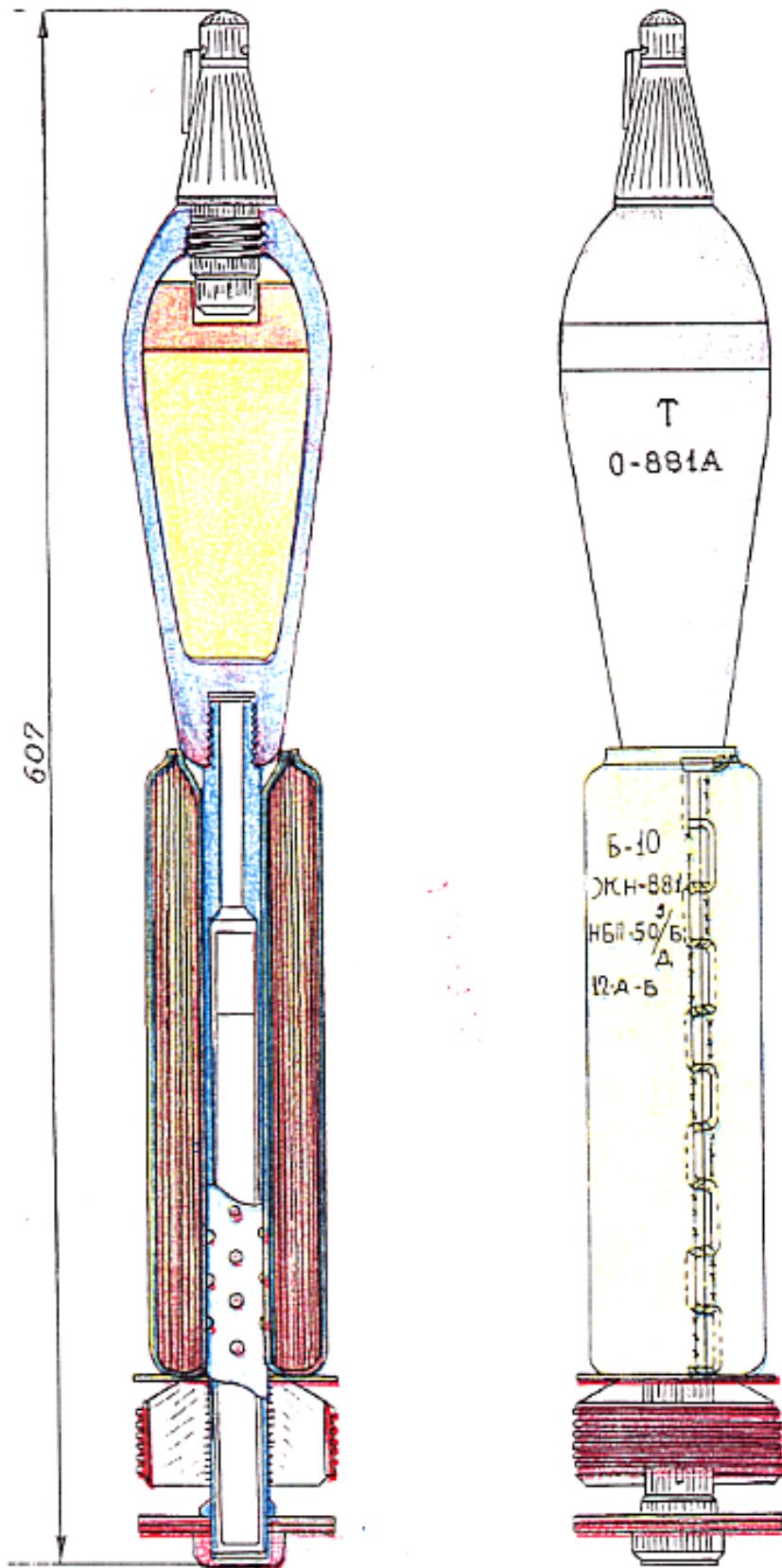

Figure 3-3 82 mm. recoilless gun round with fragmentation shell.

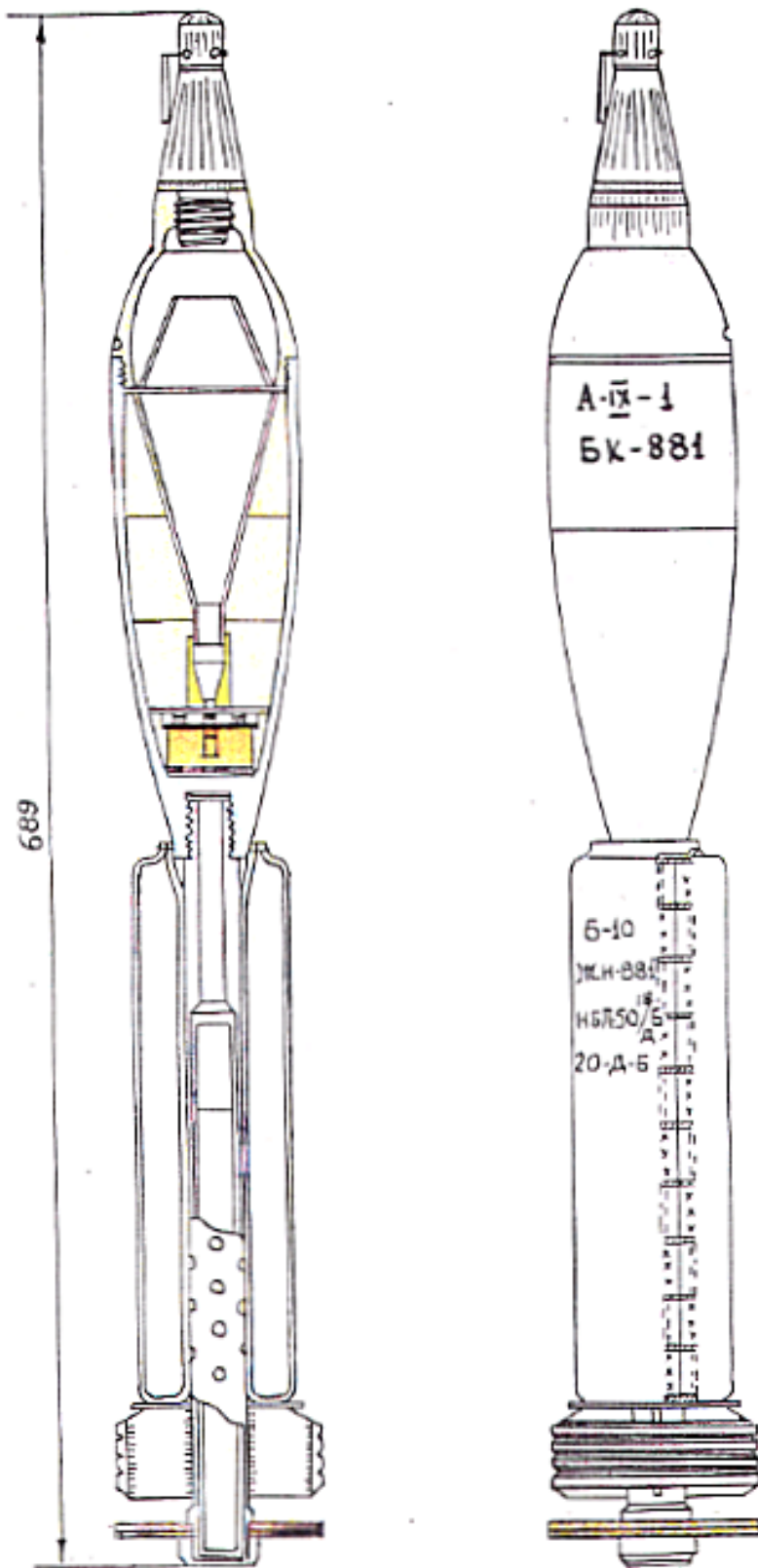

Figure 3-4 82 mm. recoilless gun round with shaped charge shell.

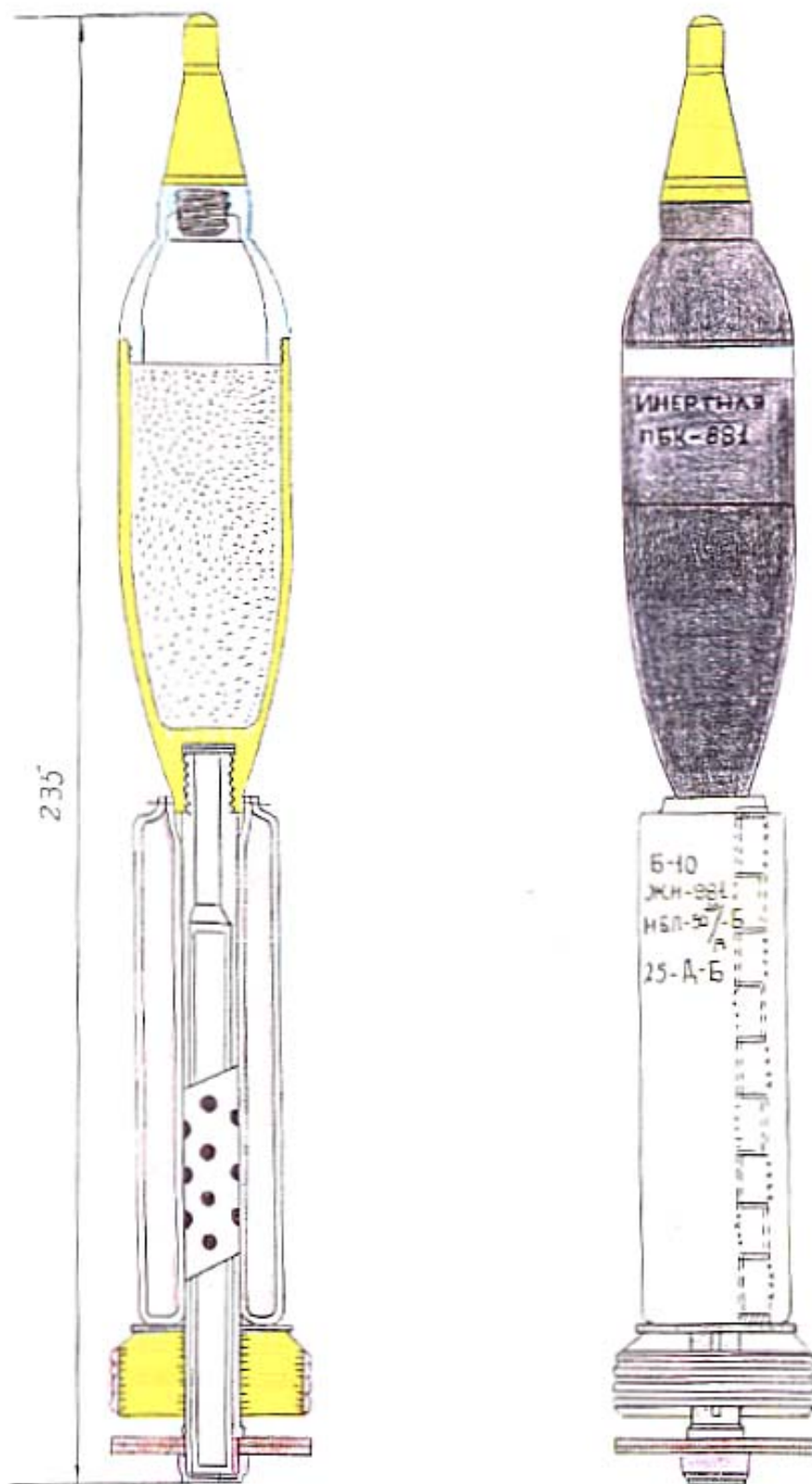
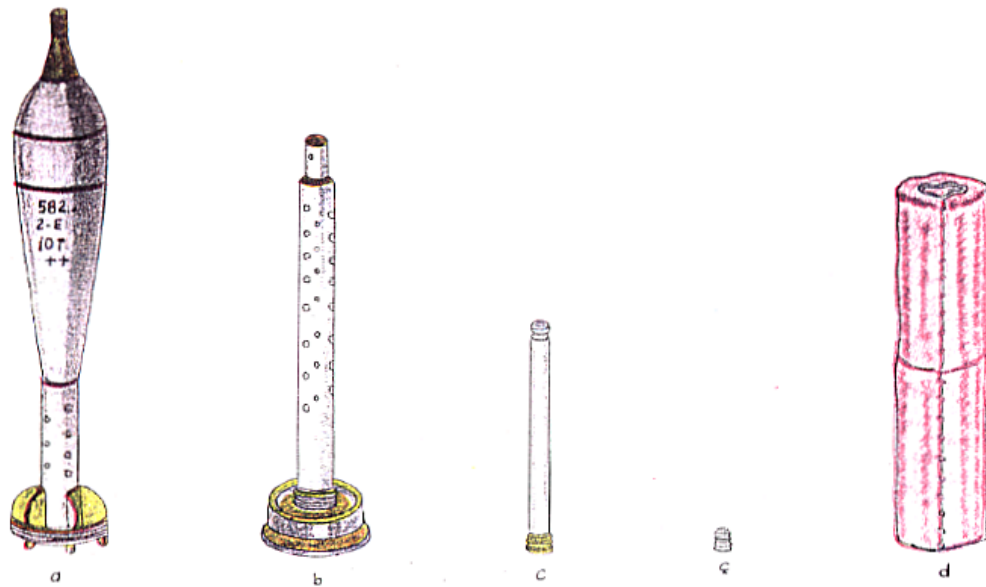

Figure 3-5 82 mm. recoilless gun round with practice shell.



- a. Shell
- b. Retaining member for propellant charge.
- c. Primer/primer cartridge.
- d. Propellant charge.

Figure 3-6 Components of rounds for 107 mm. recoilless gun.

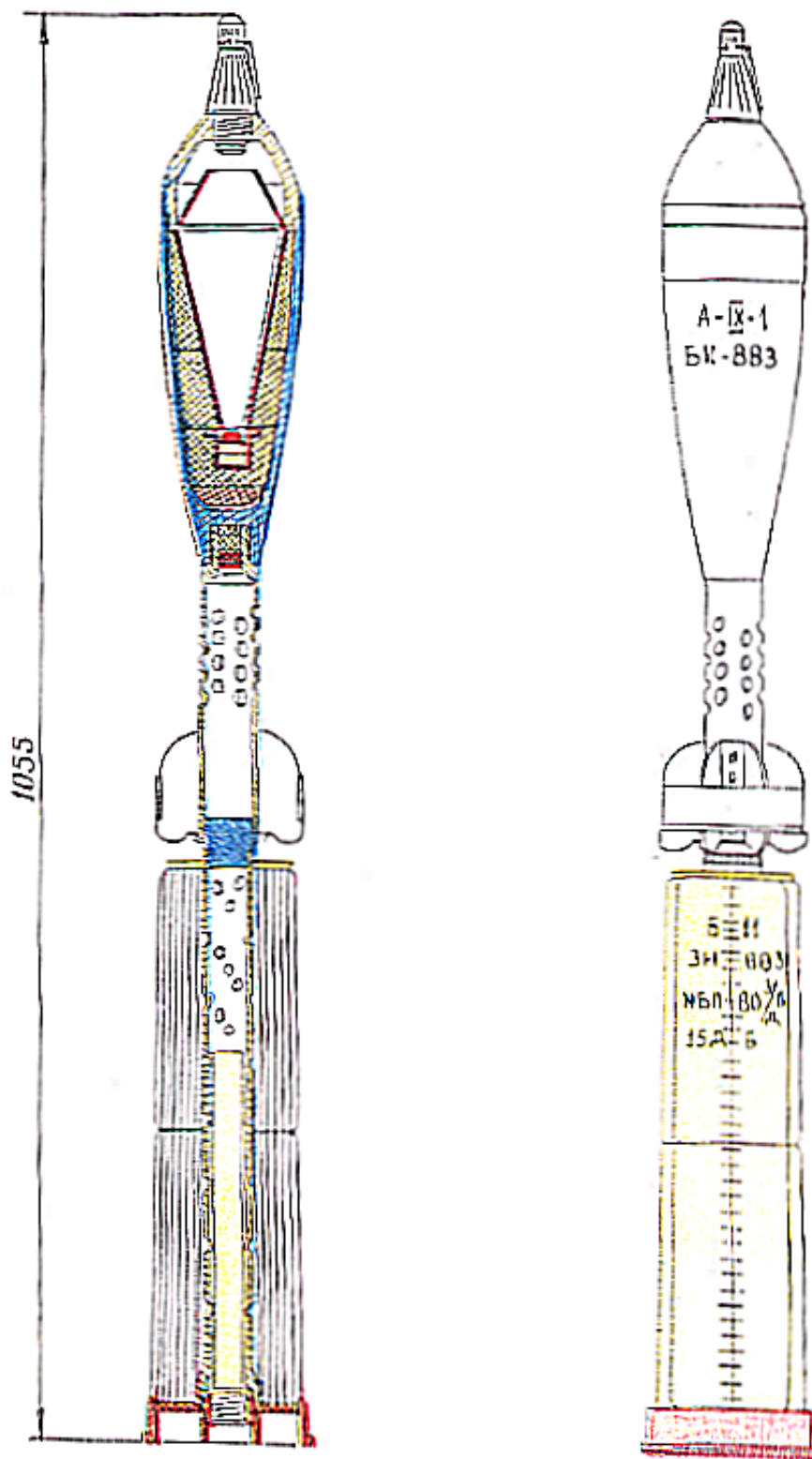

Figure 3-7 Round for 107 mm. recoilless gun with shaped charge shell.

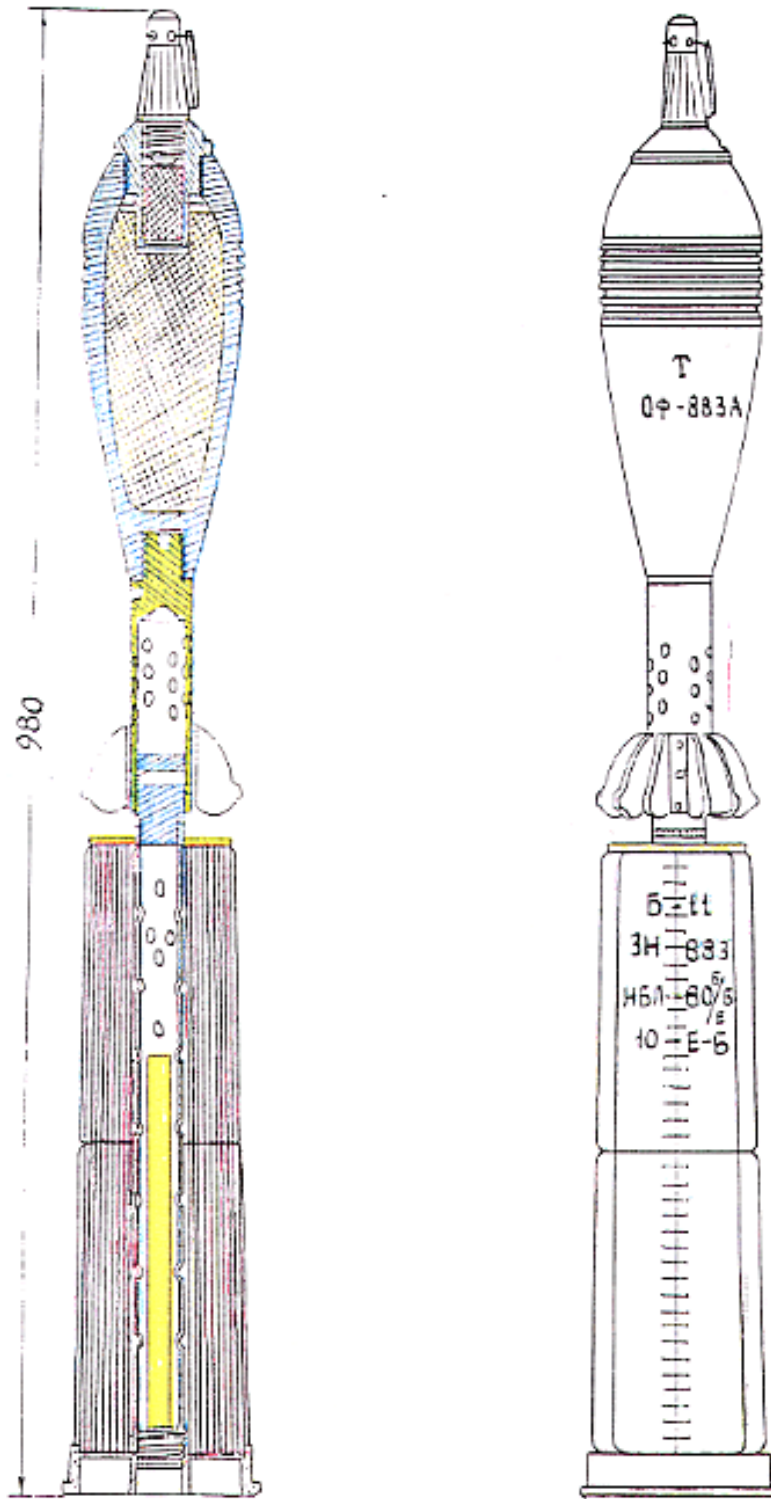

Figure 3-8 Round for 107 mm. recoilless gun with HE-fragmentation shell.

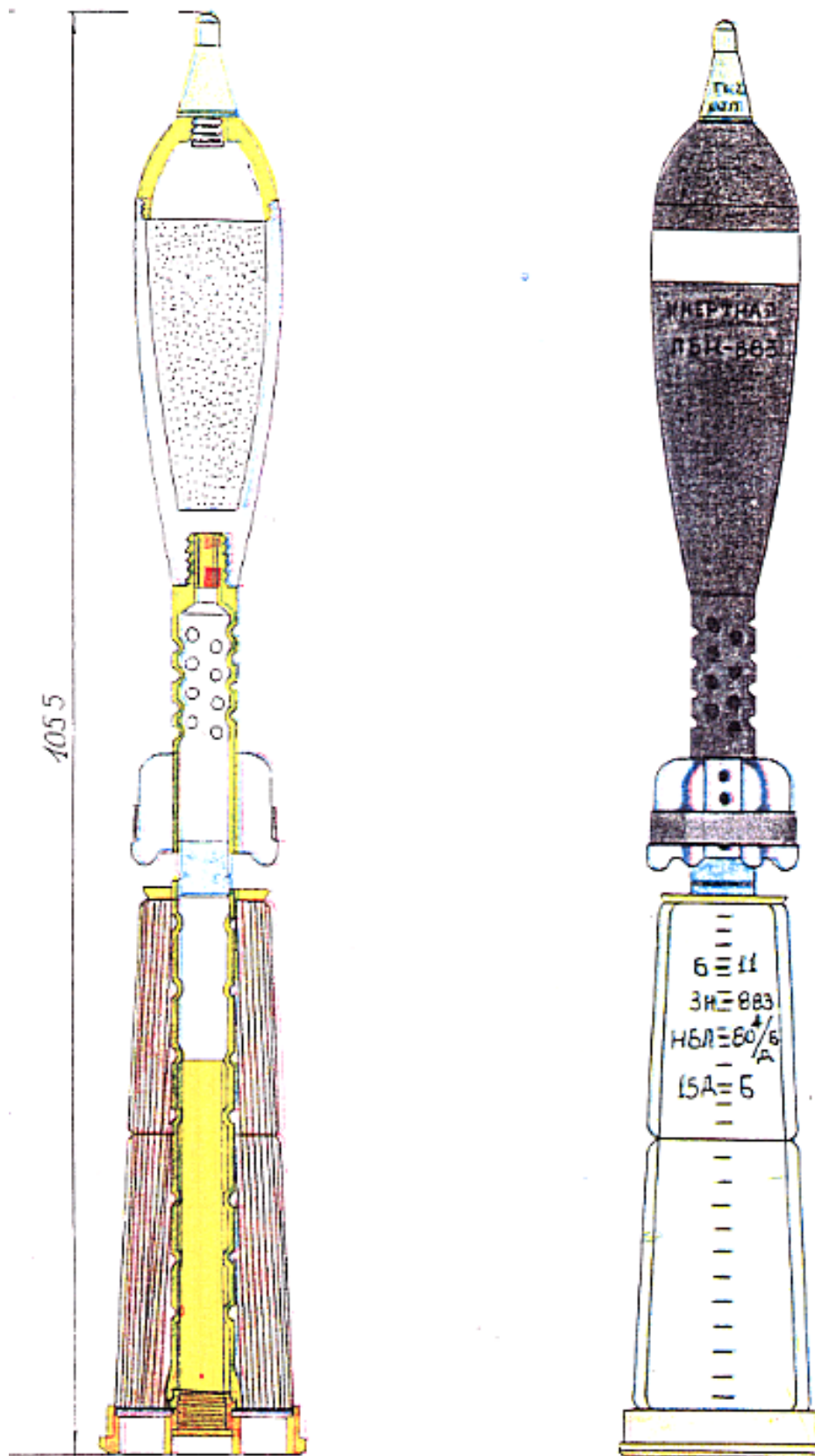

Figure 3-9 Round for 107 mm. recoilless gun with practice shell.

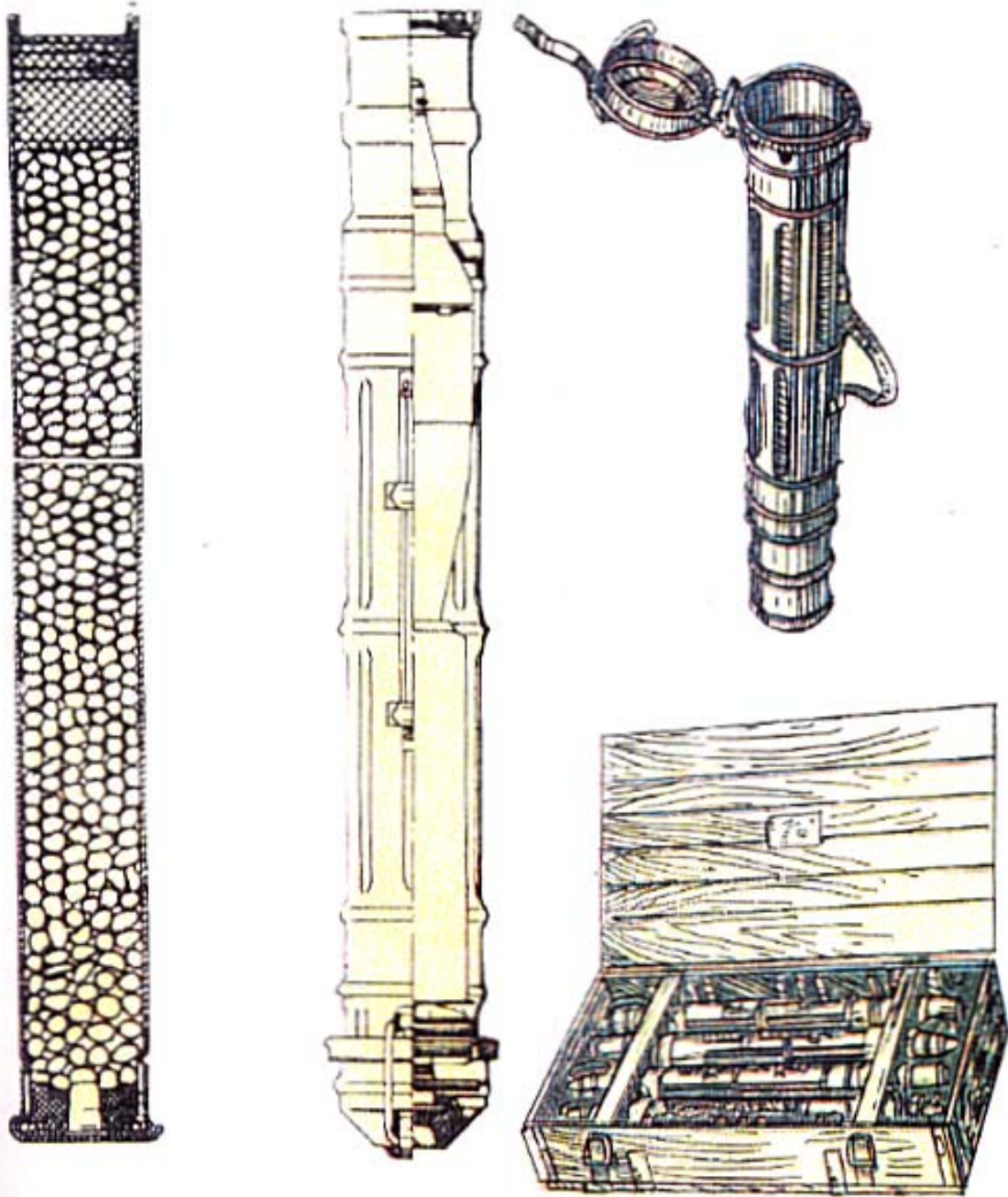
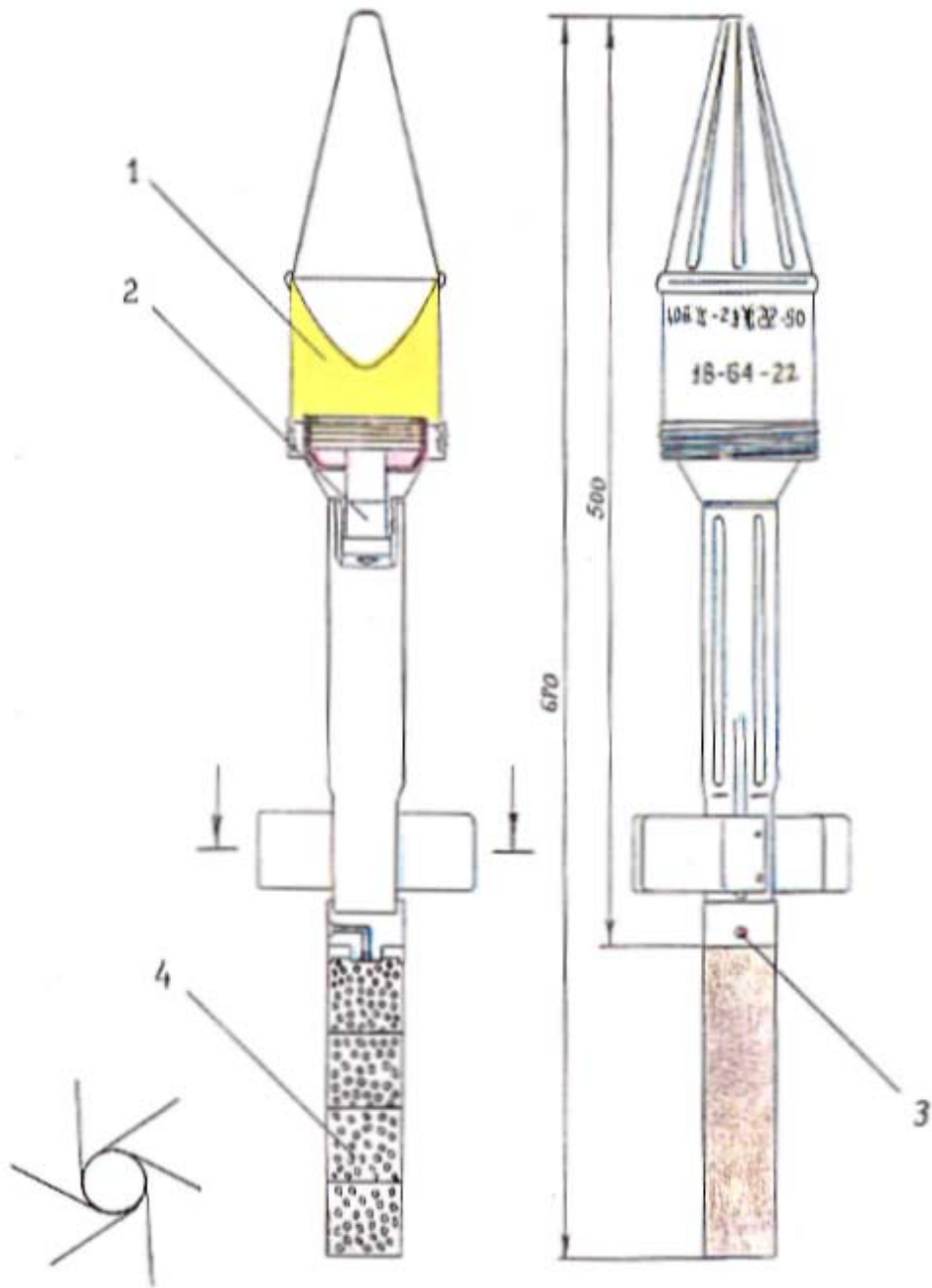

Figure 3-10 Construction of primer cartridge for recoilless gun propellant charges.

Figure 3-11 Method of packing recoilless rounds in container and box.

PART IV
DRAWINGS OF GRENADE LAUNCHER MUNITIONS

There is no page 258. The next page is 259.



1. Explosive.
2. Fuze.
3. Primer.
4. Gunpowder.

Figure 4-1 Shaped charge projectile for 40 mm. grenade launcher (light) model 56.

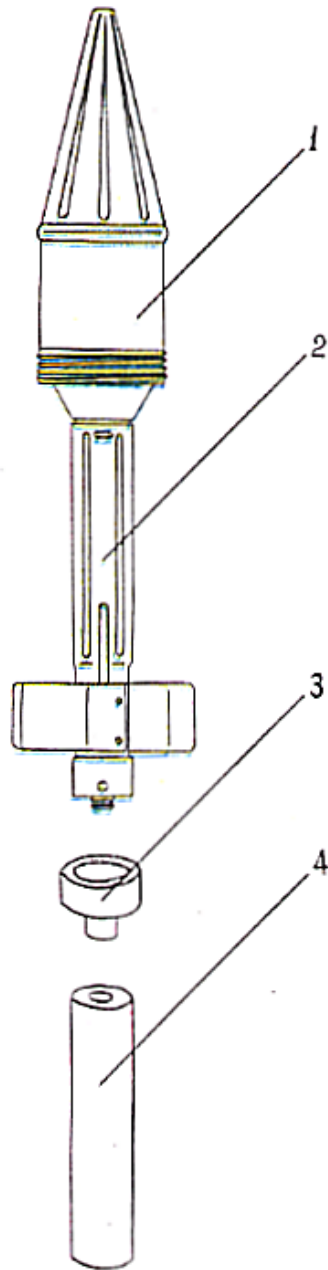

1. Projectile body.
2. Stabiliser with fins.
3. Cap.
4. Propellant charge – gunpowder.

Figure 4-2 Components of shaped charge projectile for 40 mm. grenade launcher (light) model 56.

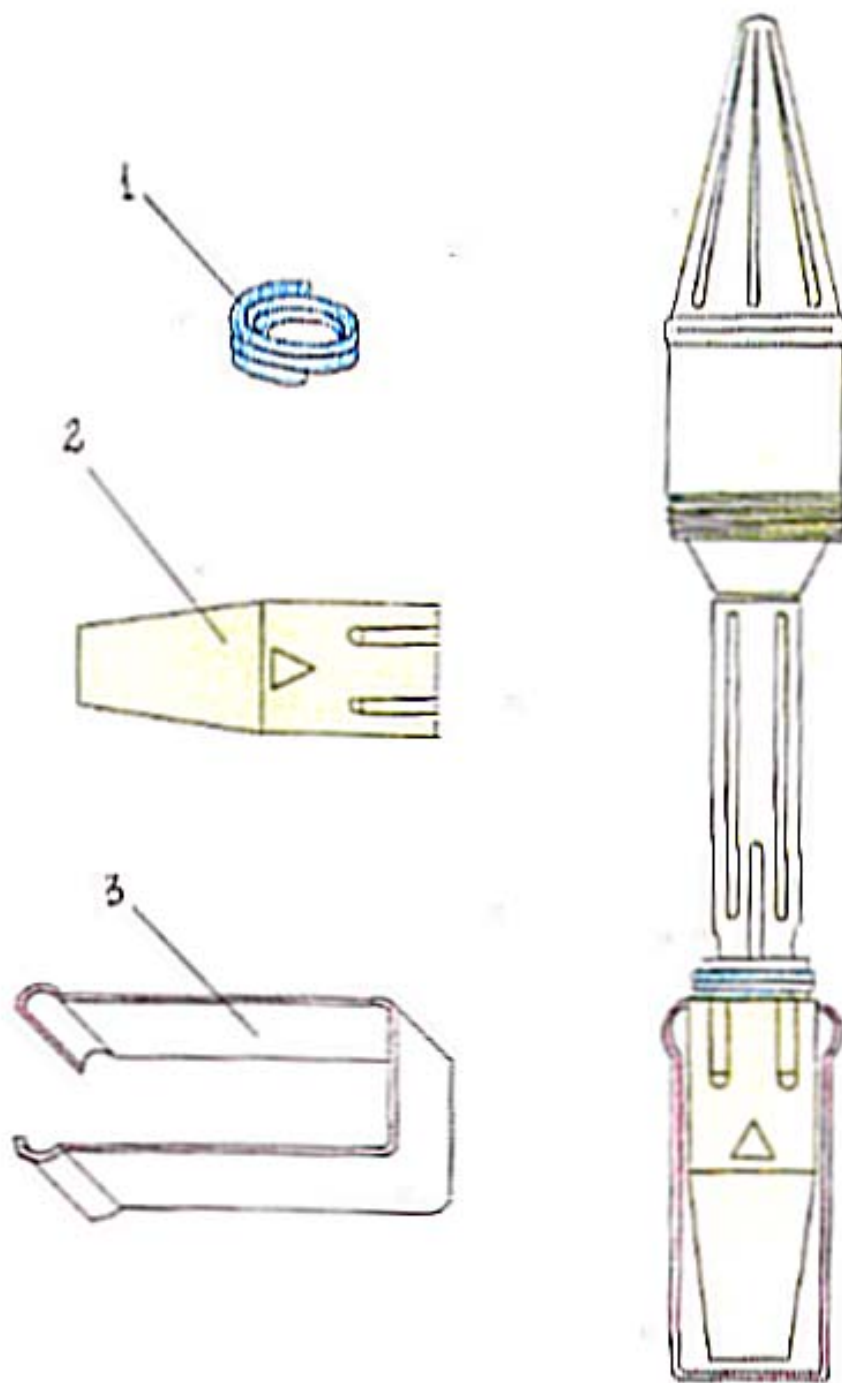

- | | | |
|----|----|--------------------|
| 1. | - | Projectile |
| 2. | 1. | Wire ring. |
| 3. | 2. | Conical container. |
| 4. | 3. | Pronged clip. |

Figure 4-3 Method of placing wire ring over stabiliser fins of shaped charge projectile for 40 mm. grenade launcher (light) model 56.

Figure 4-4 Shaped charge grenade for 40 mm. grenade launcher (light) model 1969.

- | | | | |
|-----|---|------|---------------------------------------|
| 1. | Protective cap. | 18. | Steel tube. |
| 2. | Cap. | 19. | Primer. |
| 3. | Sleeve. | 20. | Firing pin. |
| 4. | Hemisphere. | 21. | Connecting sleeve. |
| 5. | Piezo-electric quartz. | 22. | Cardboard tube. |
| 6. | Steel cylinder. | 23. | Rivet. |
| 7. | Plastic sleeve. | 24. | Base of fin. |
| 8. | Retaining sleeve. | 25. | Body of projectile. |
| 9. | Contact sleeve. | 26. | Fixed washer. |
| 10. | Nose of projectile | 27. | Capping. |
| 11. | Funnel. | 28.) | Cylinder. |
| 12. | Cover for shaped charge hollow section. | 29.) | |
| 13. | Explosive | 30. | Spring. |
| 14. | Plastic sleeve. | 31. | Plastic box of gunpowder. with smoke. |
| 15. | Fuze mechanism. | 32. | Gunpowder with smoke. |
| 16. | Base of projectile. | 33. | Stabiliser fins (retracted.) |
| 17. | Reactive gunpowder. | 34. | Smokeless gunpowder strips. |

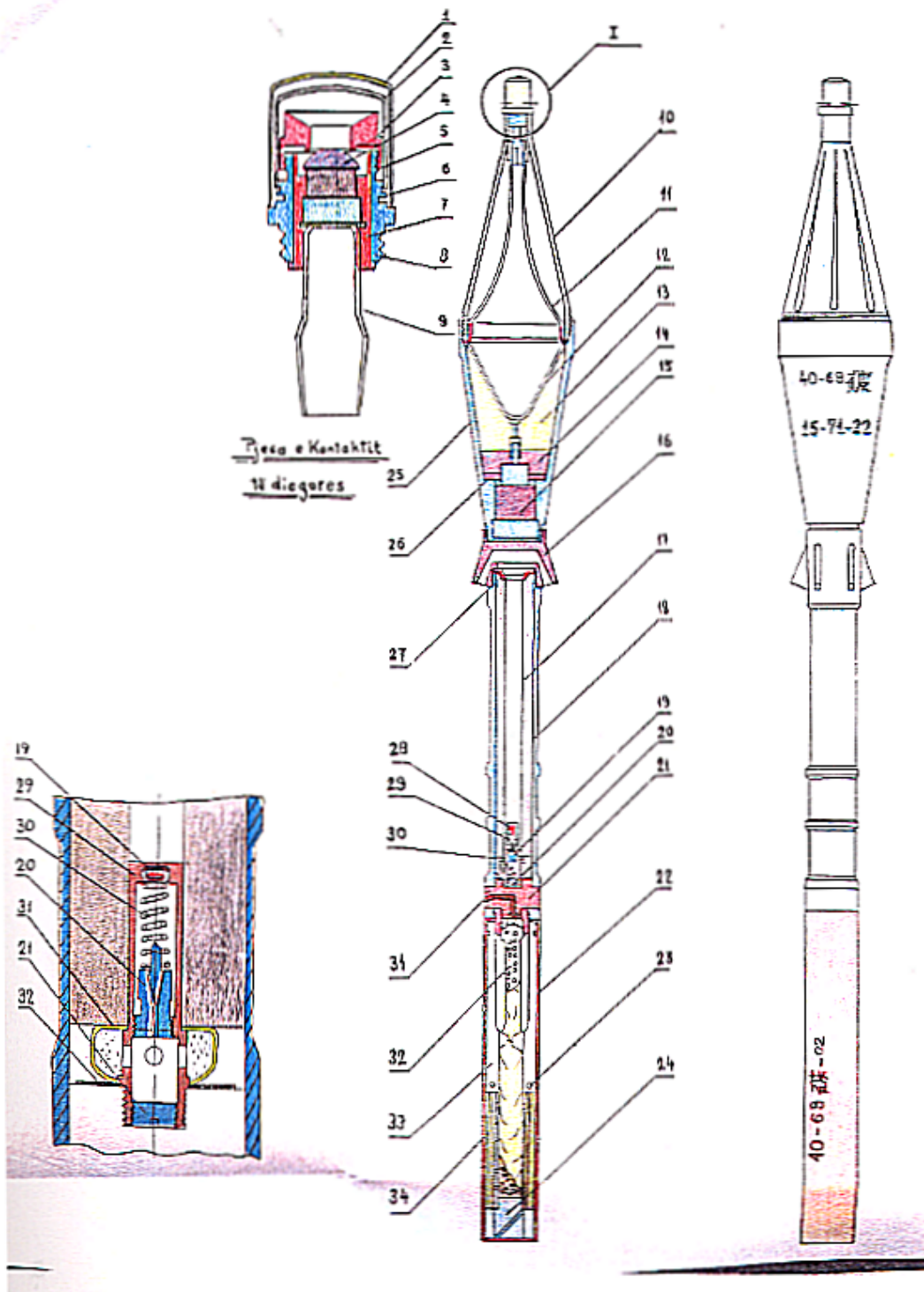

Figure 4-4 In the drawing items 1-8 appear above the words "Contact part of fuze."

PART V

DRAWINGS OF MORTAR MUNITIONS

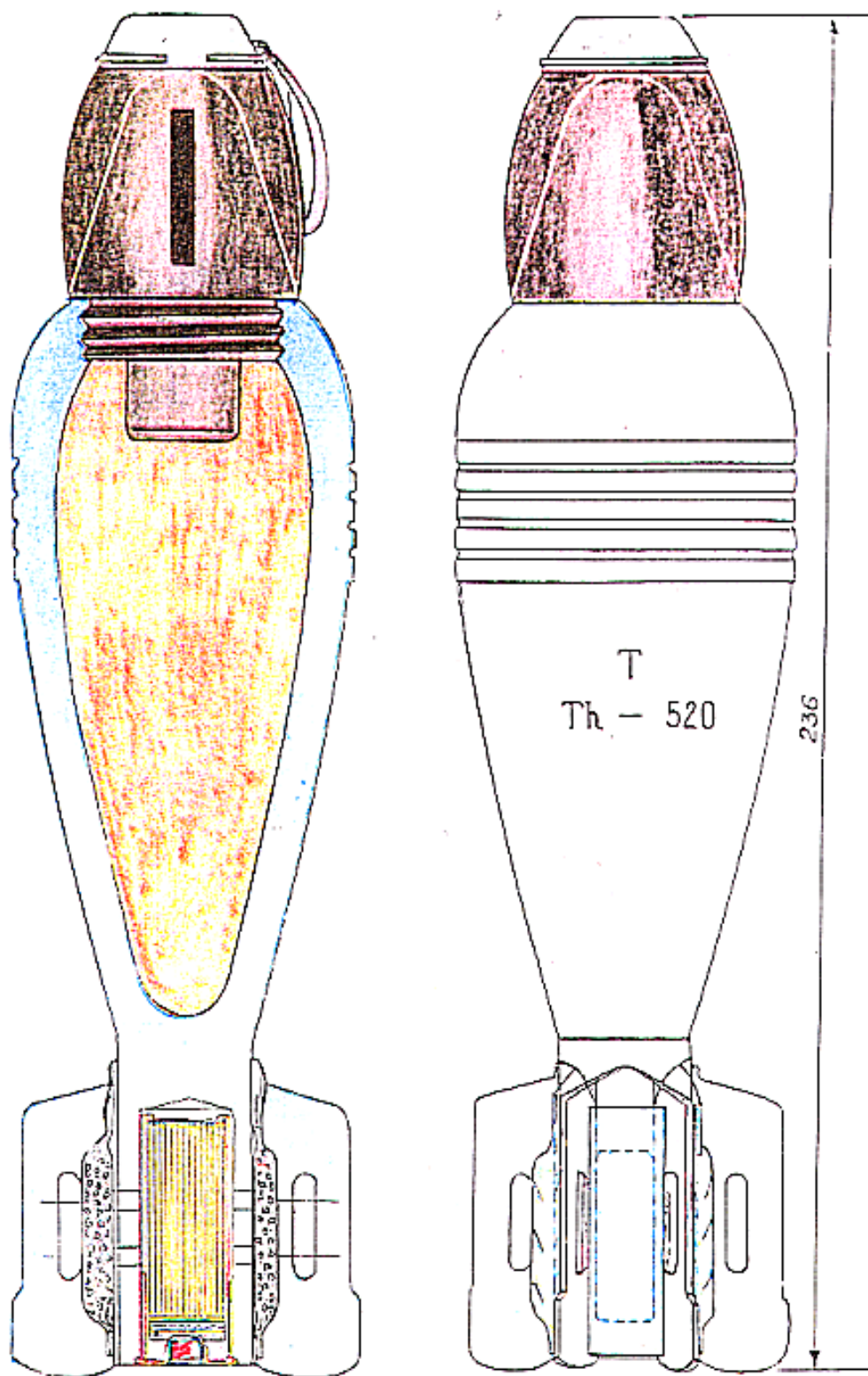

Figure 5-1 Eight-finned fragmentation bomb for 60 mm. mortar.

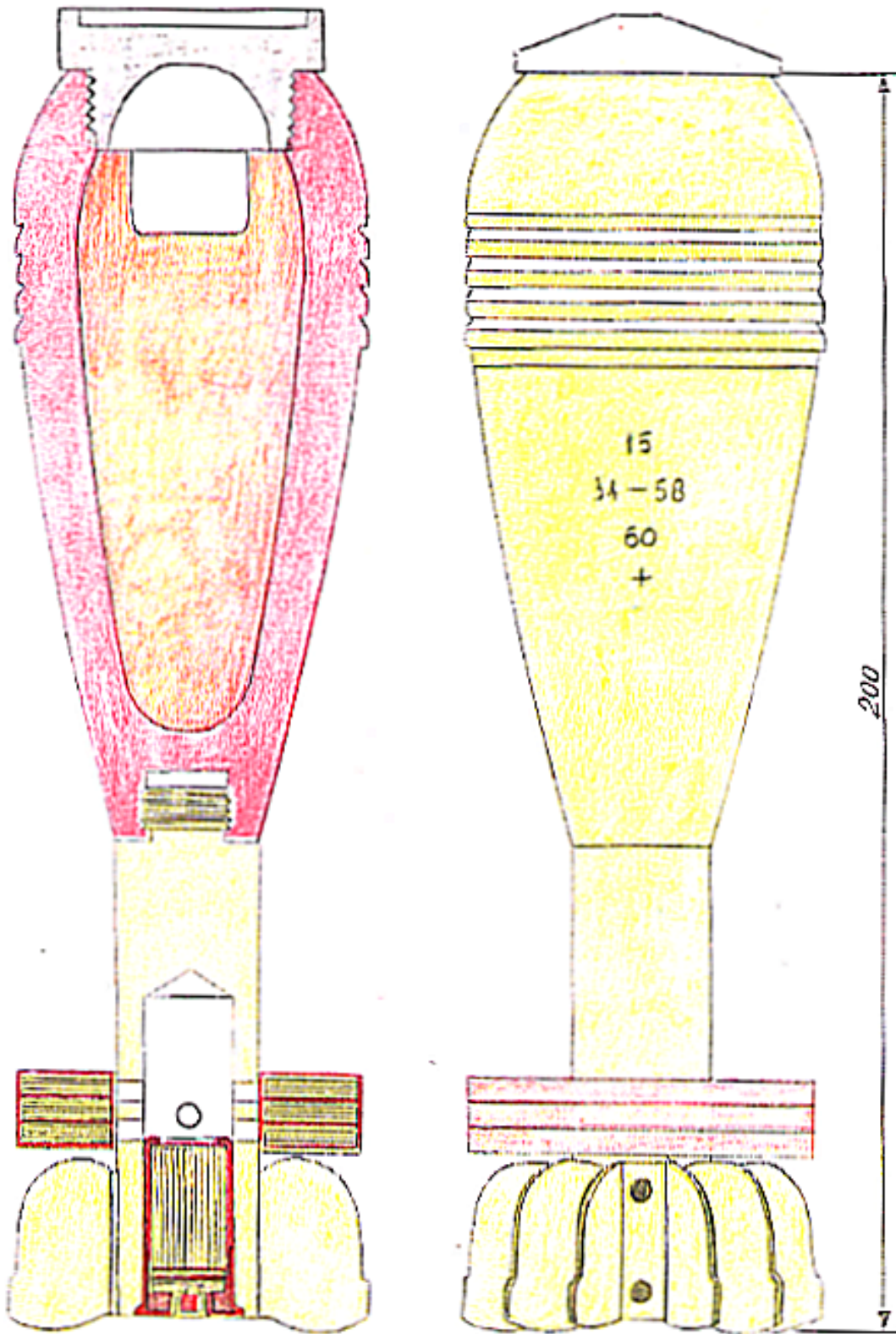

Figure 5-2 Ten-finned fragmentation bomb for 60 mm. mortar.

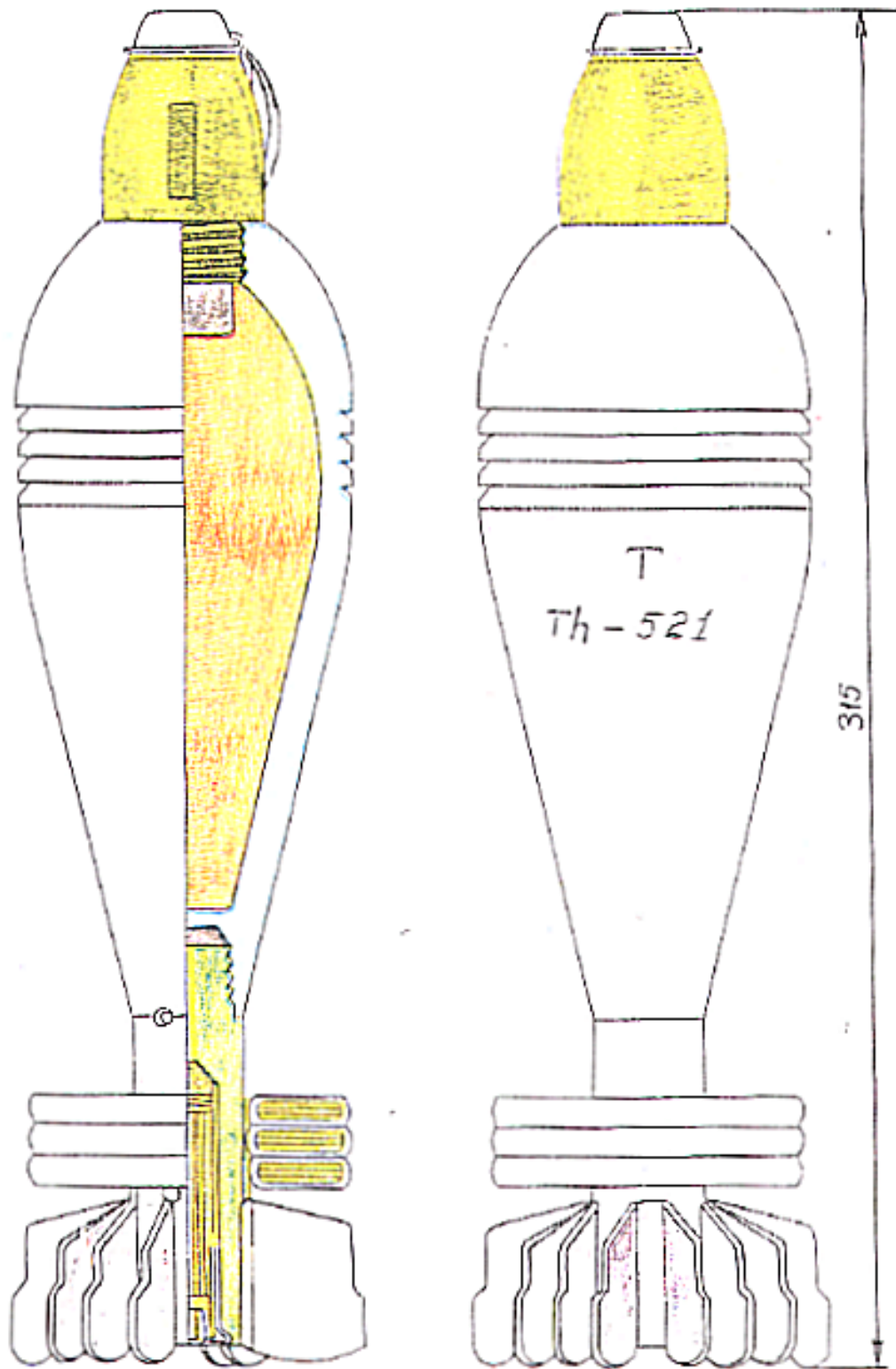

Figure 5-3 Ten-finned fragmentation bomb for 82 mm. mortar.

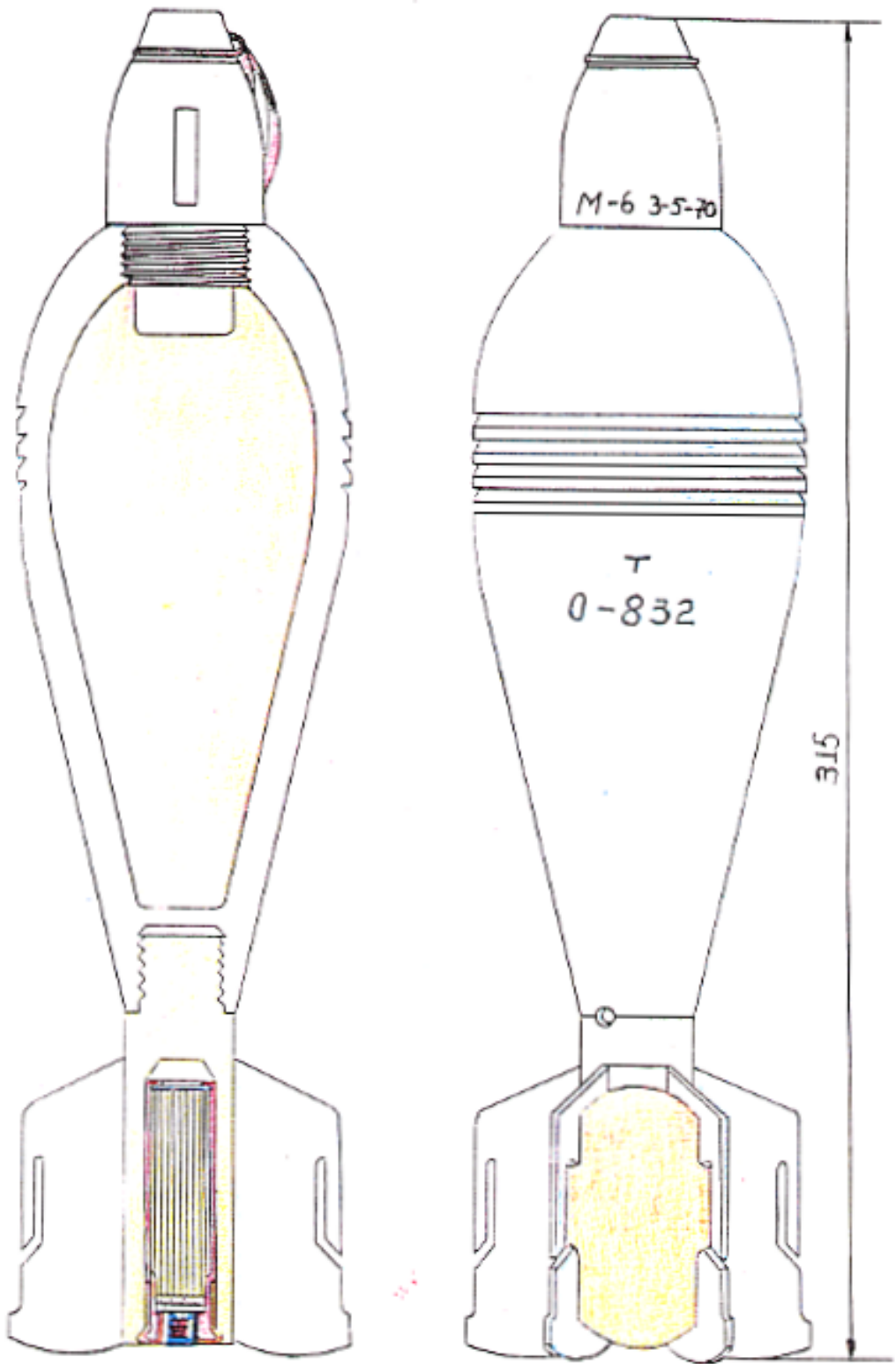

Figure 5-4 Six-finned fragmentation bomb for 82 mm. mortar.

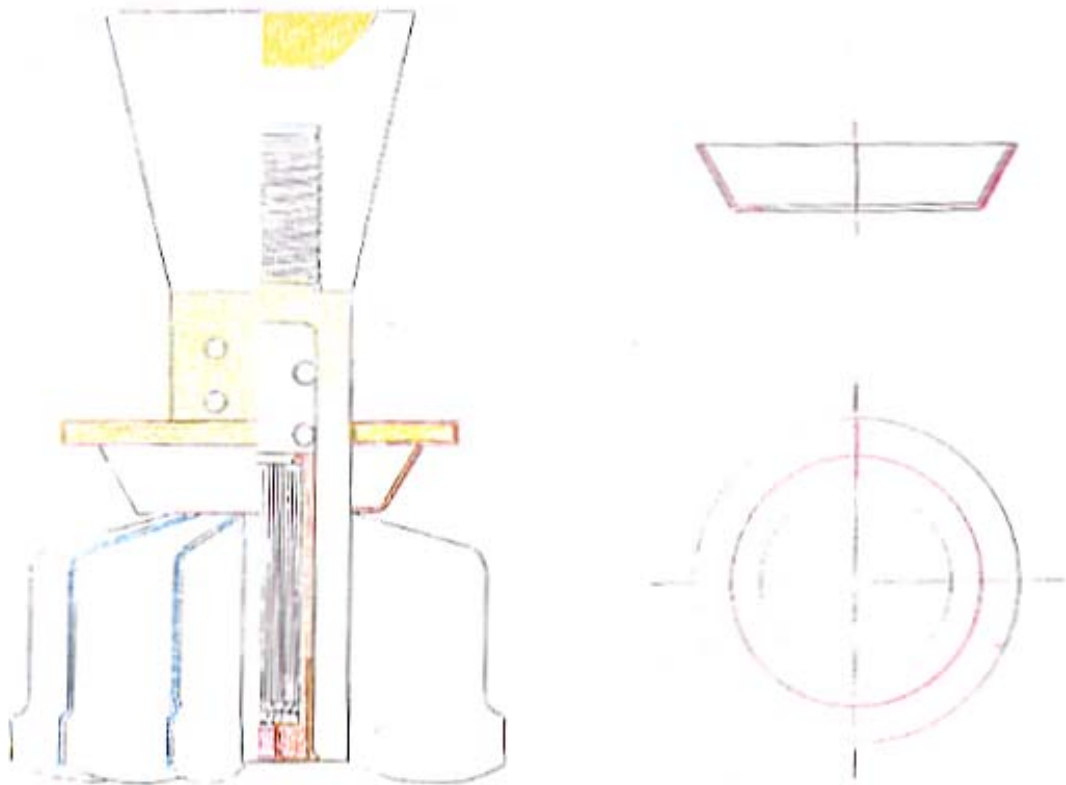

Figure 5-5 Additional annular nitro-cellulose (Pyroxiline) charge for propellant charge for 82 mm. mortar; Positioning of this in the projectile.

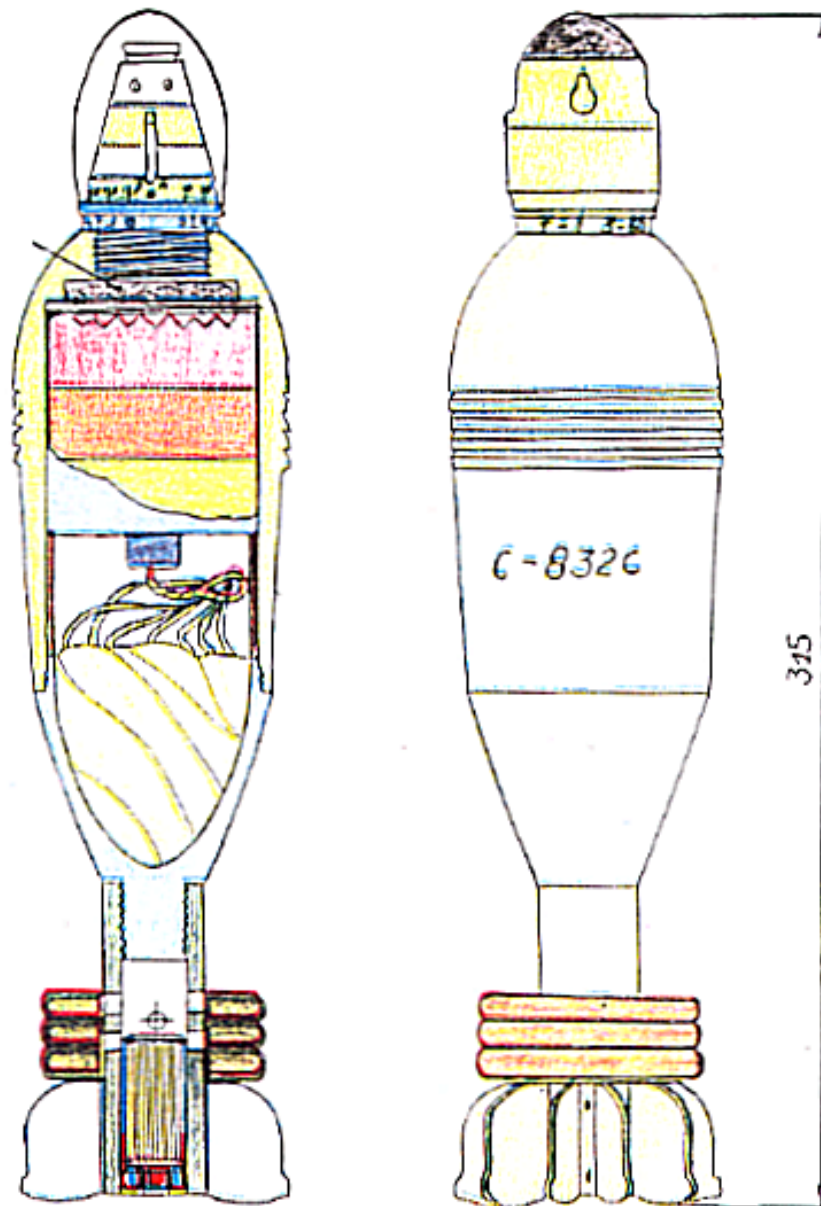

Figure 5-6 82 mm. mortar bomb – illuminating.

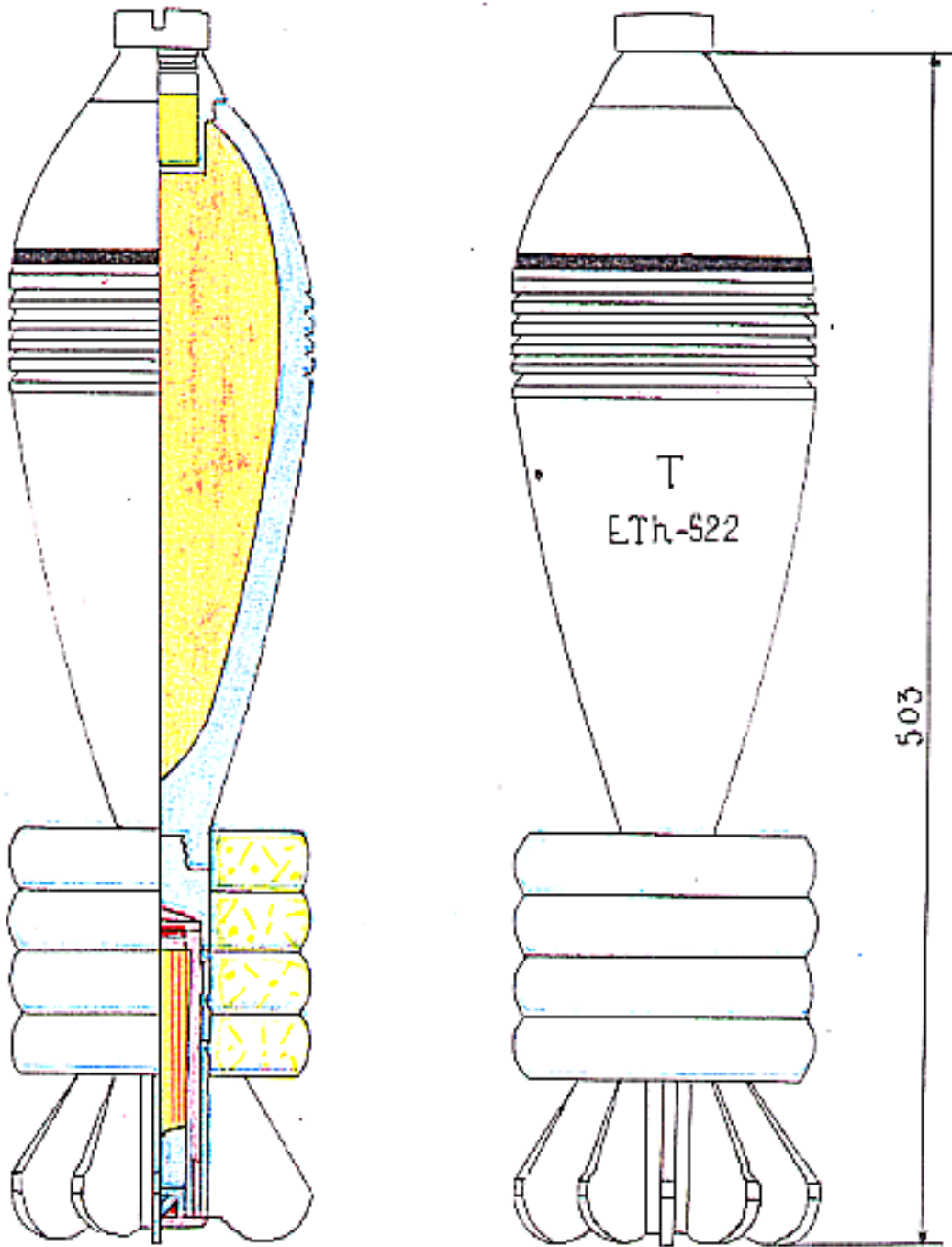

Figure 5-7 Cast-iron HE-fragmentation bomb for 107 mm. mortar.

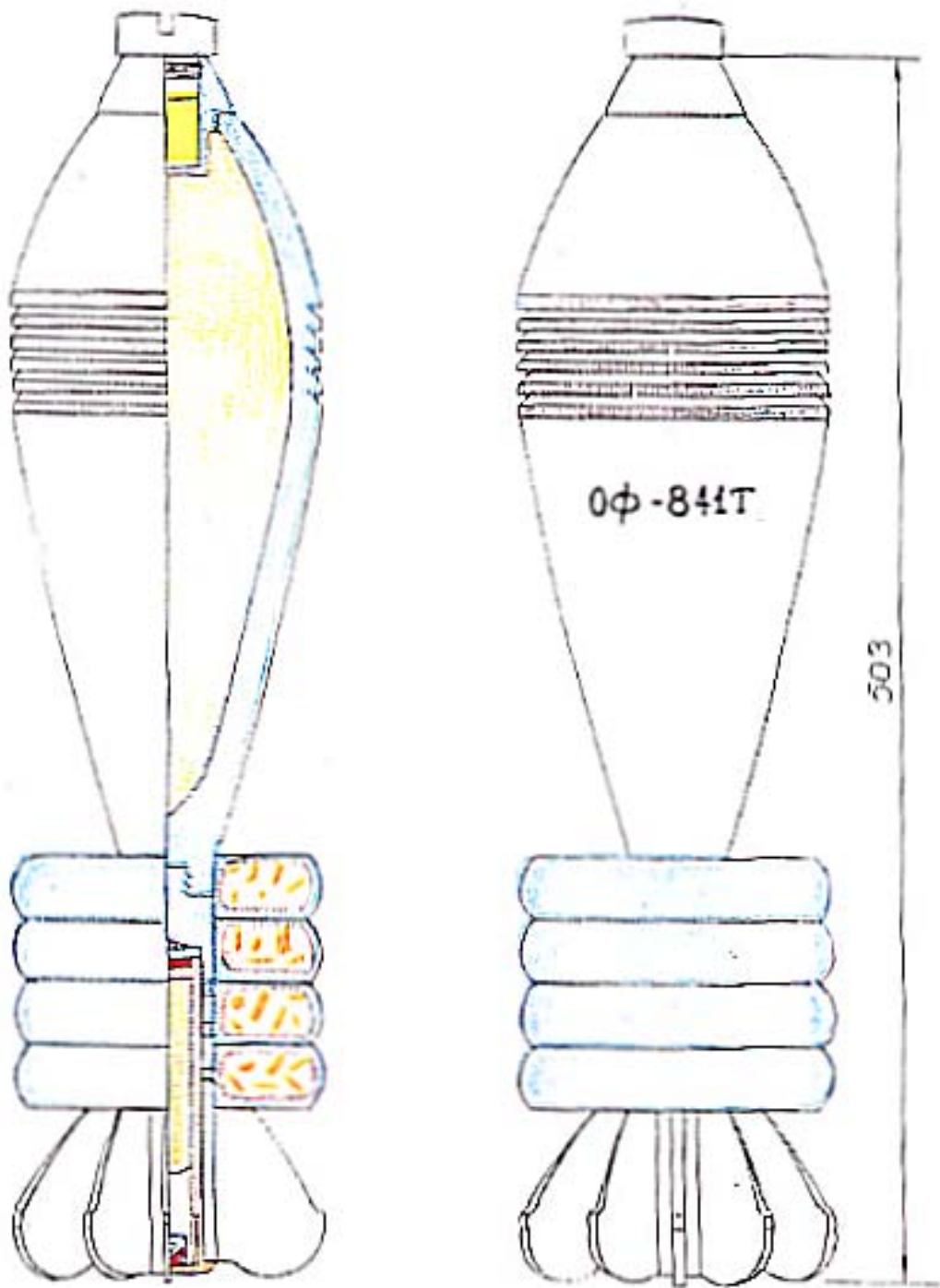

Figure 5-8 Steel HE-fragmentation bomb for 107 mm. mortar

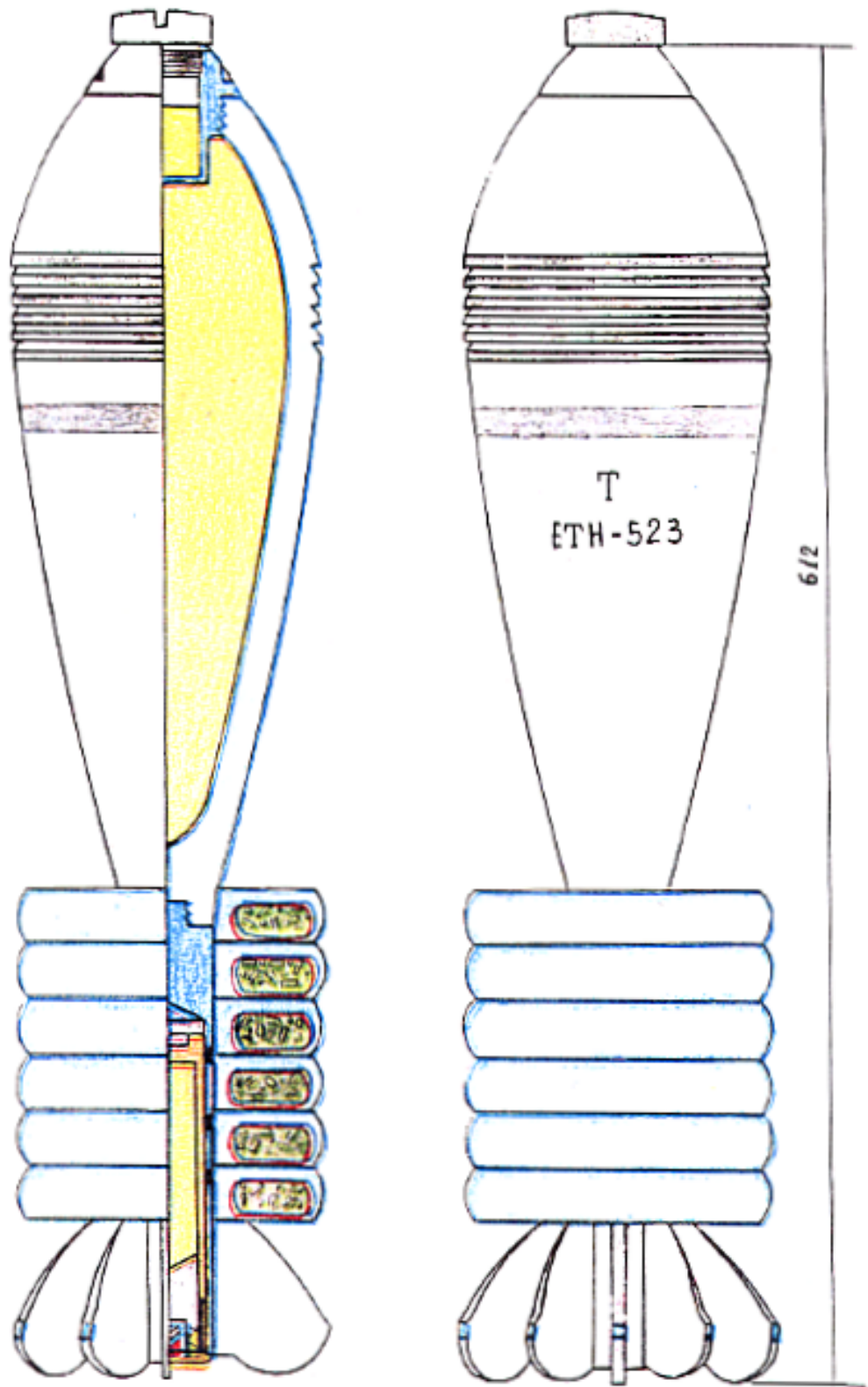

Figure 5-9 Cast-iron HE-fragmentation bomb for 120 mm. mortar.

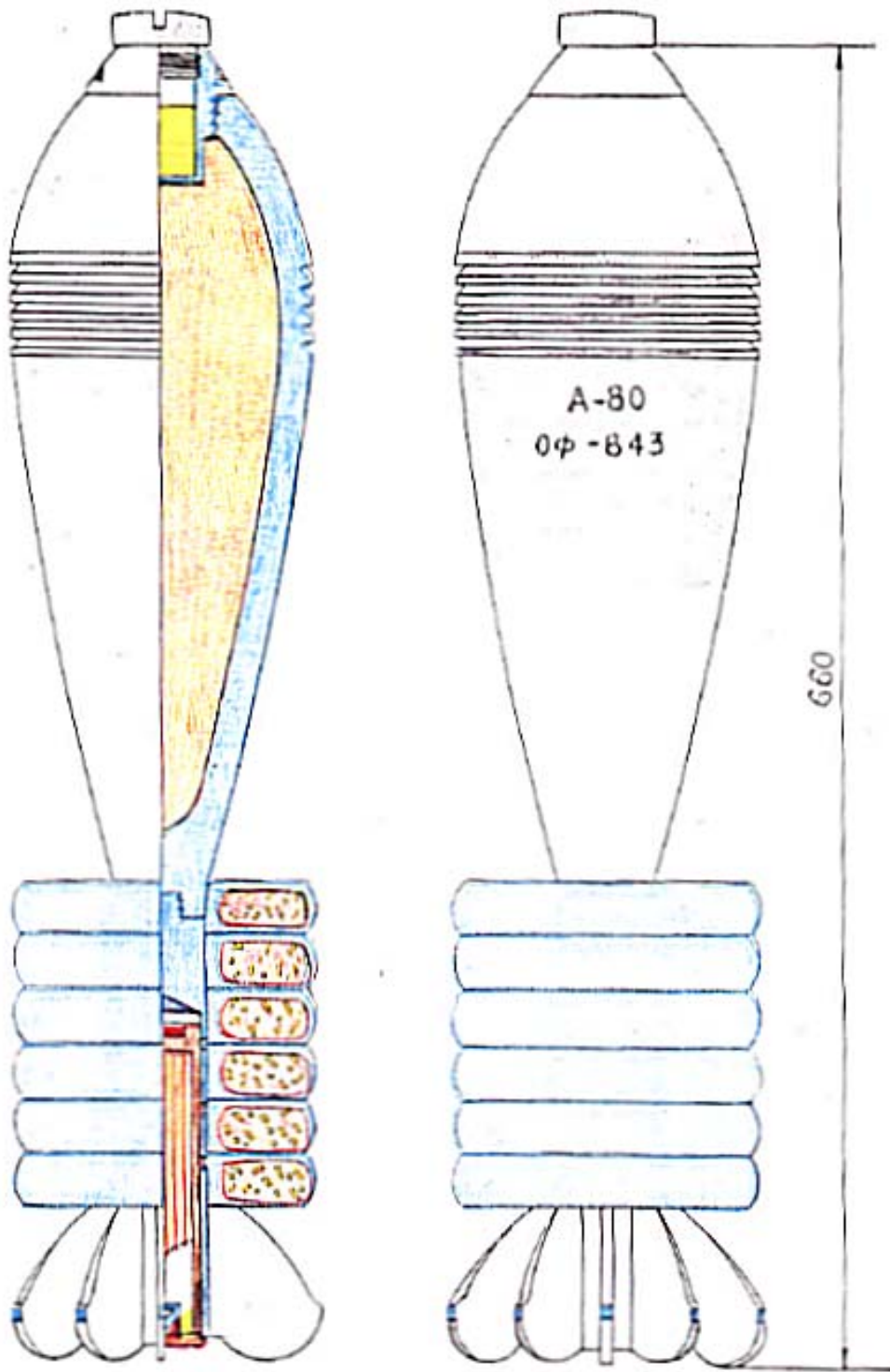

Figure 5-10 Steel HE-fragmentation bomb for 120 mm. mortar.

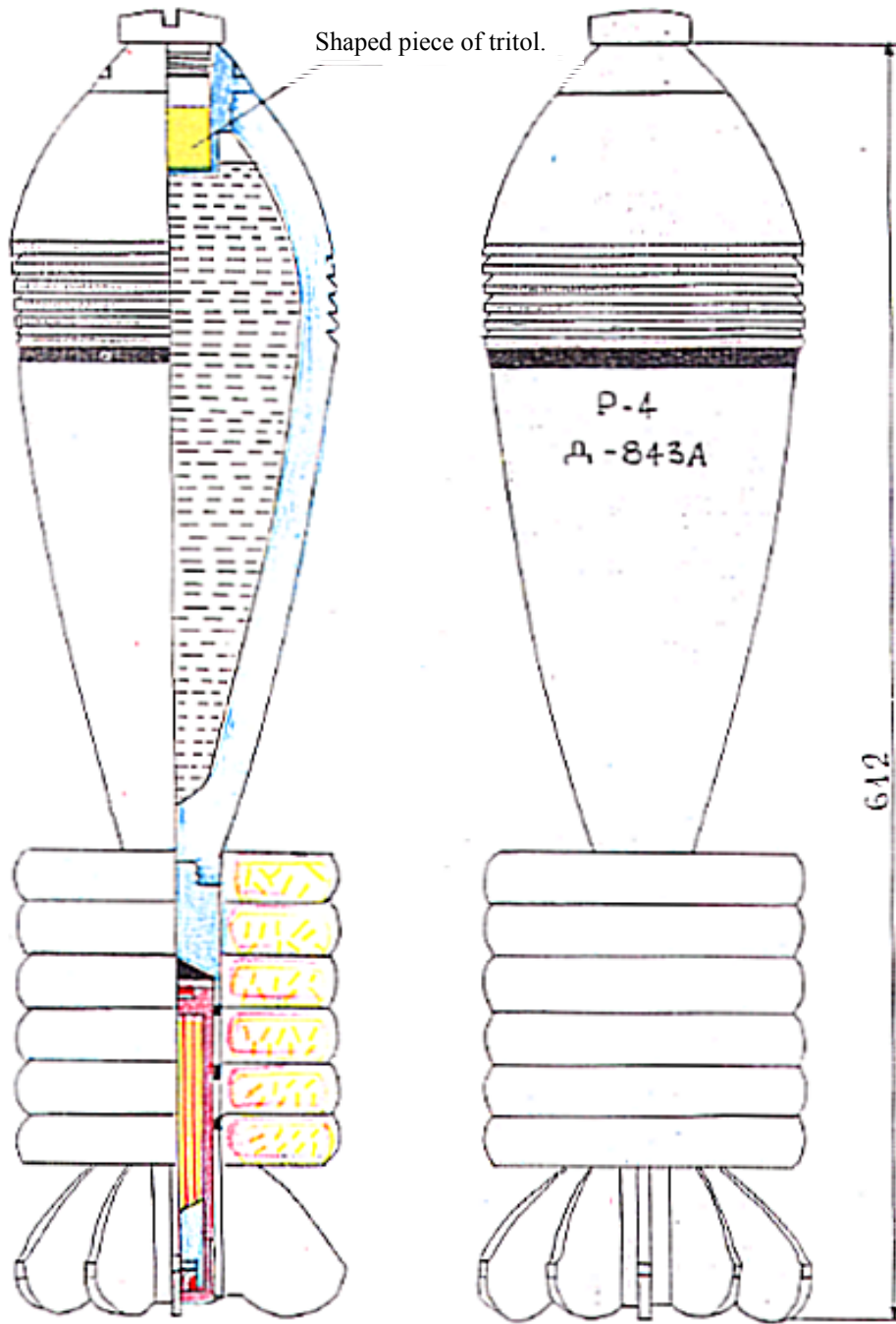

Figure 5-11 Smoke bomb for 120 mm. mortar.

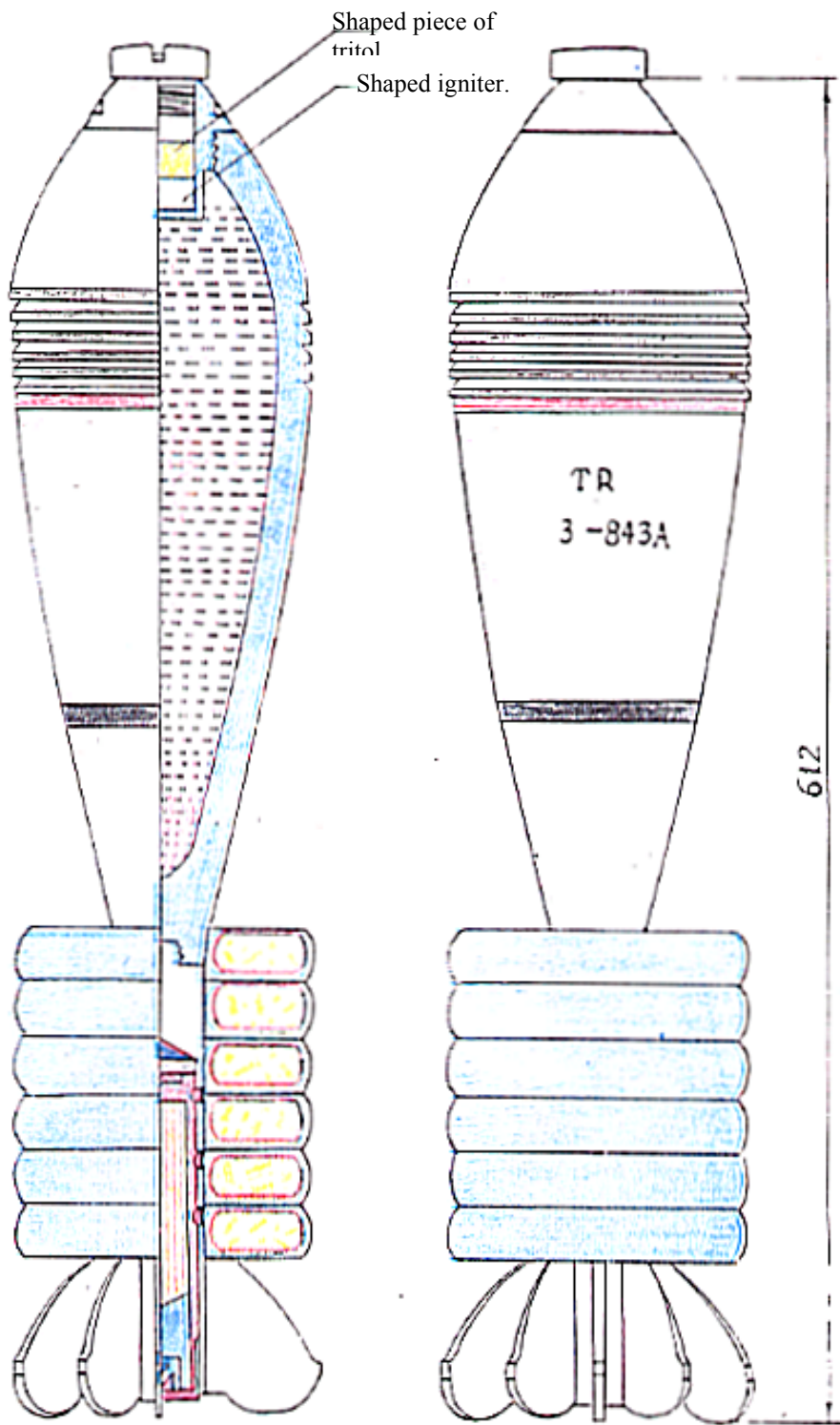

Figure 5-12 Incendiary bomb for 120 mm. mortar.

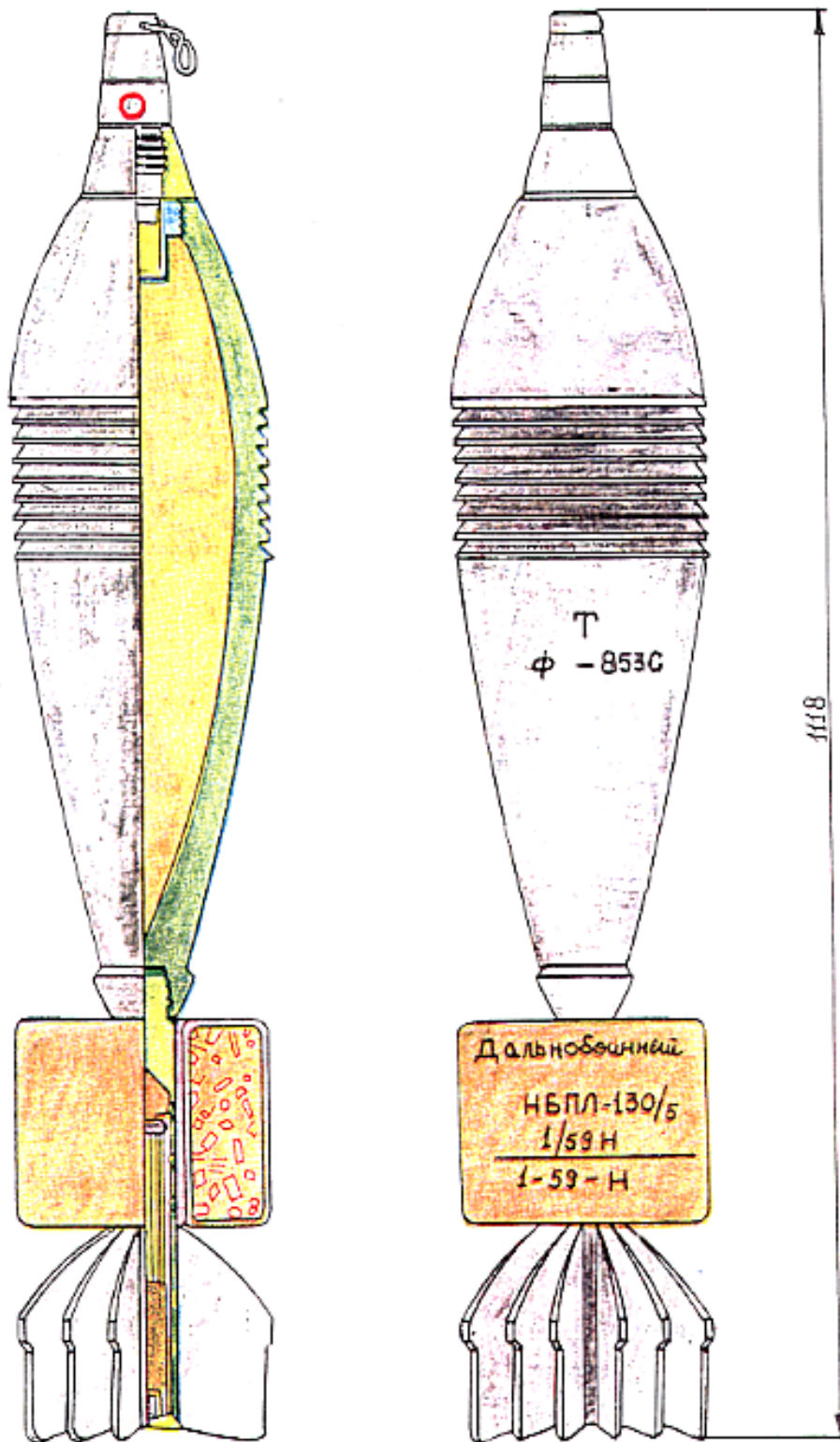

Figure 5-13 Steel HE bomb with long-range charge for 160 mm. mortar.

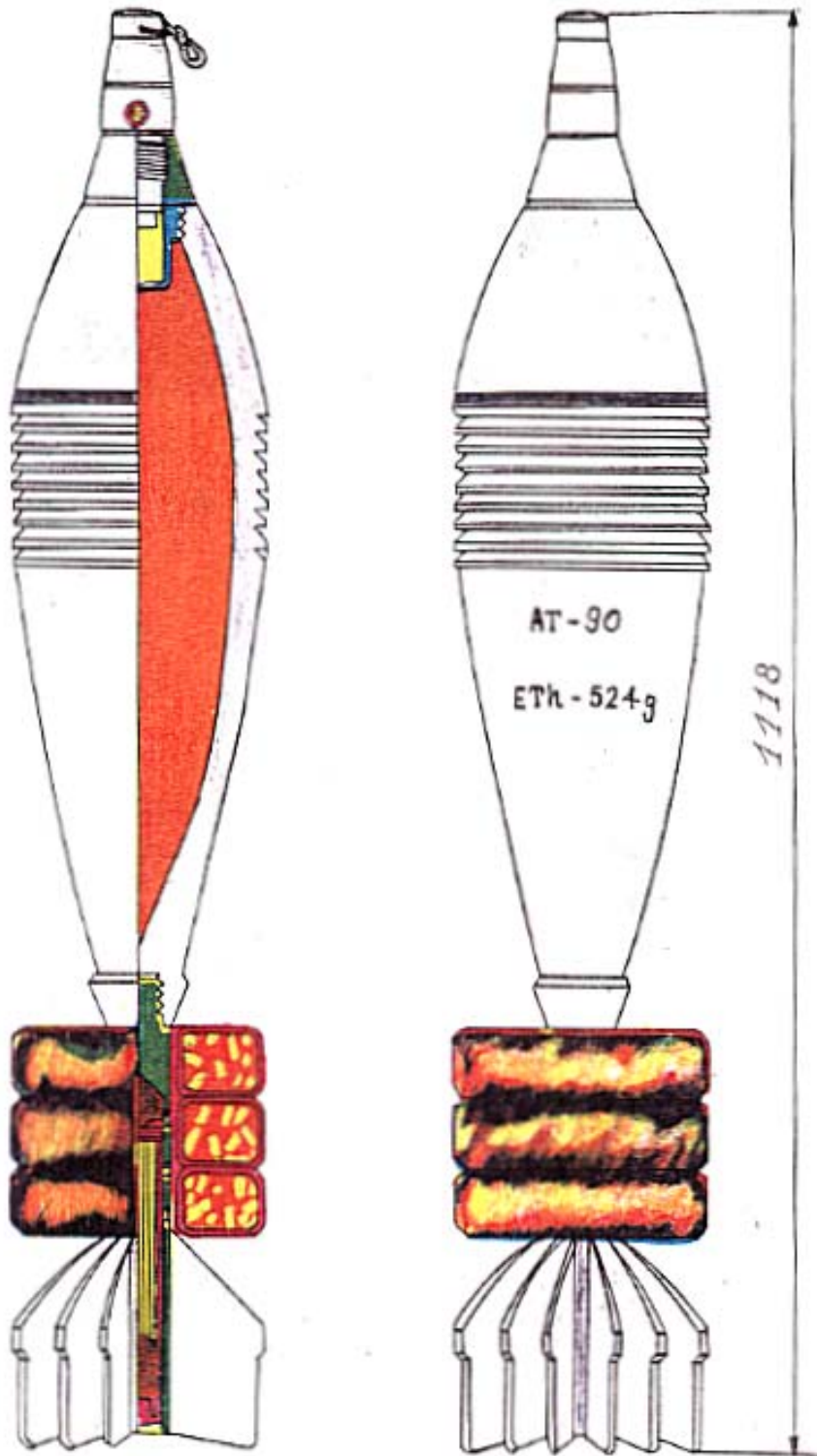

Figure 5-14 Cast-iron HE bomb with variable charge for 160 mm. mortar

PART VI

DRAWINGS OF ROCKETS

Page 290 is presumably blank. [IN ORIGINAL]

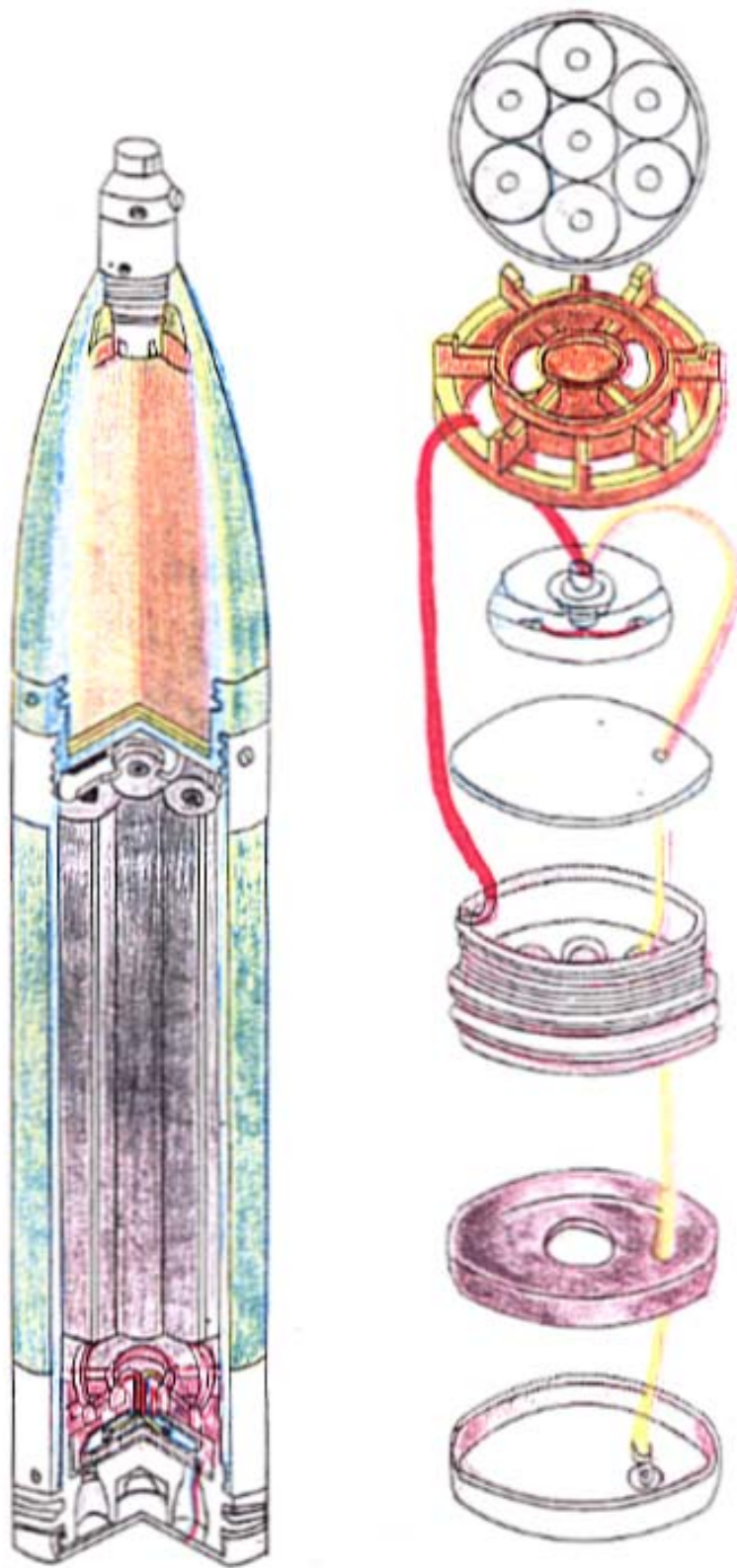

Figure 6-1 View of components of rockets for 107 mm. and 130 mm. model 63 rocket launchers.

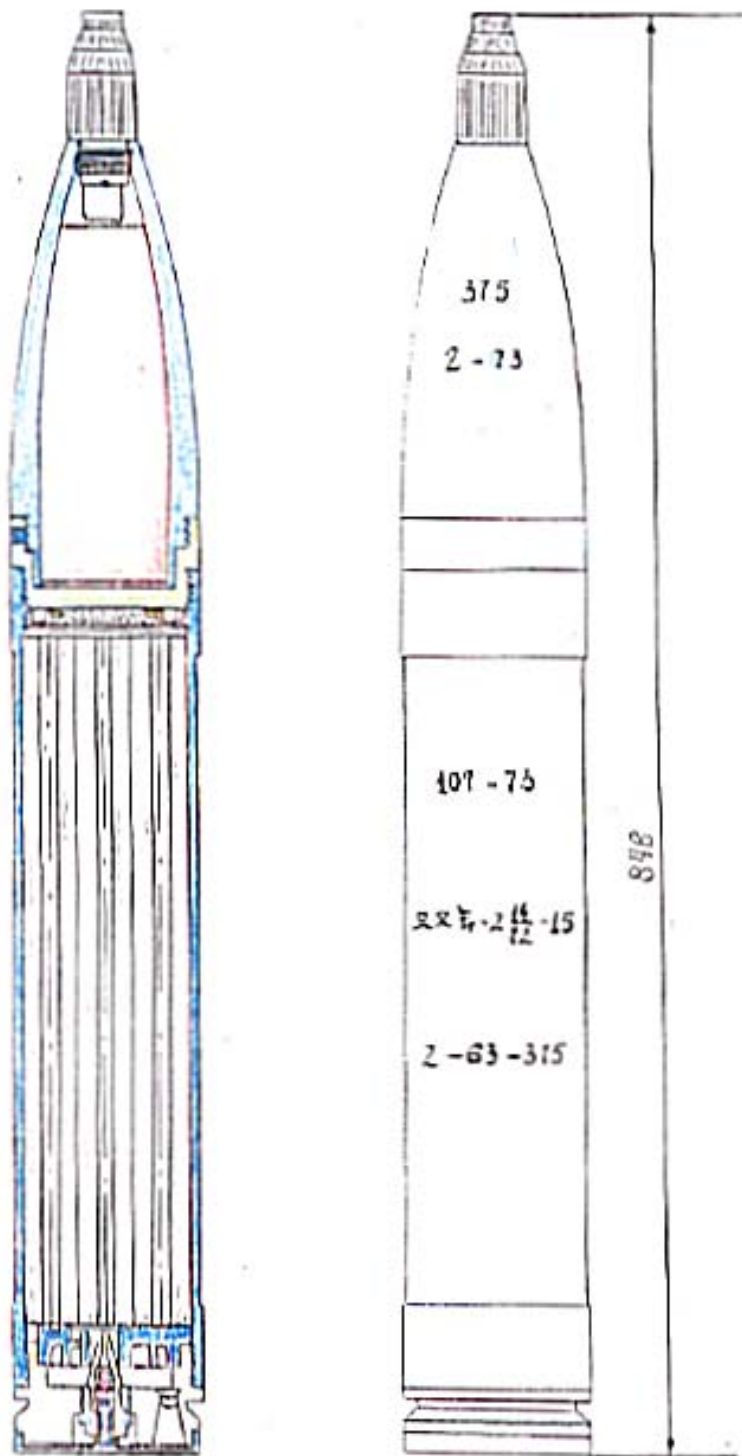

Figure 6-2 HE-fragmentation rocket for 107 mm. rocket launcher model 63 with primer placed behind rocket.

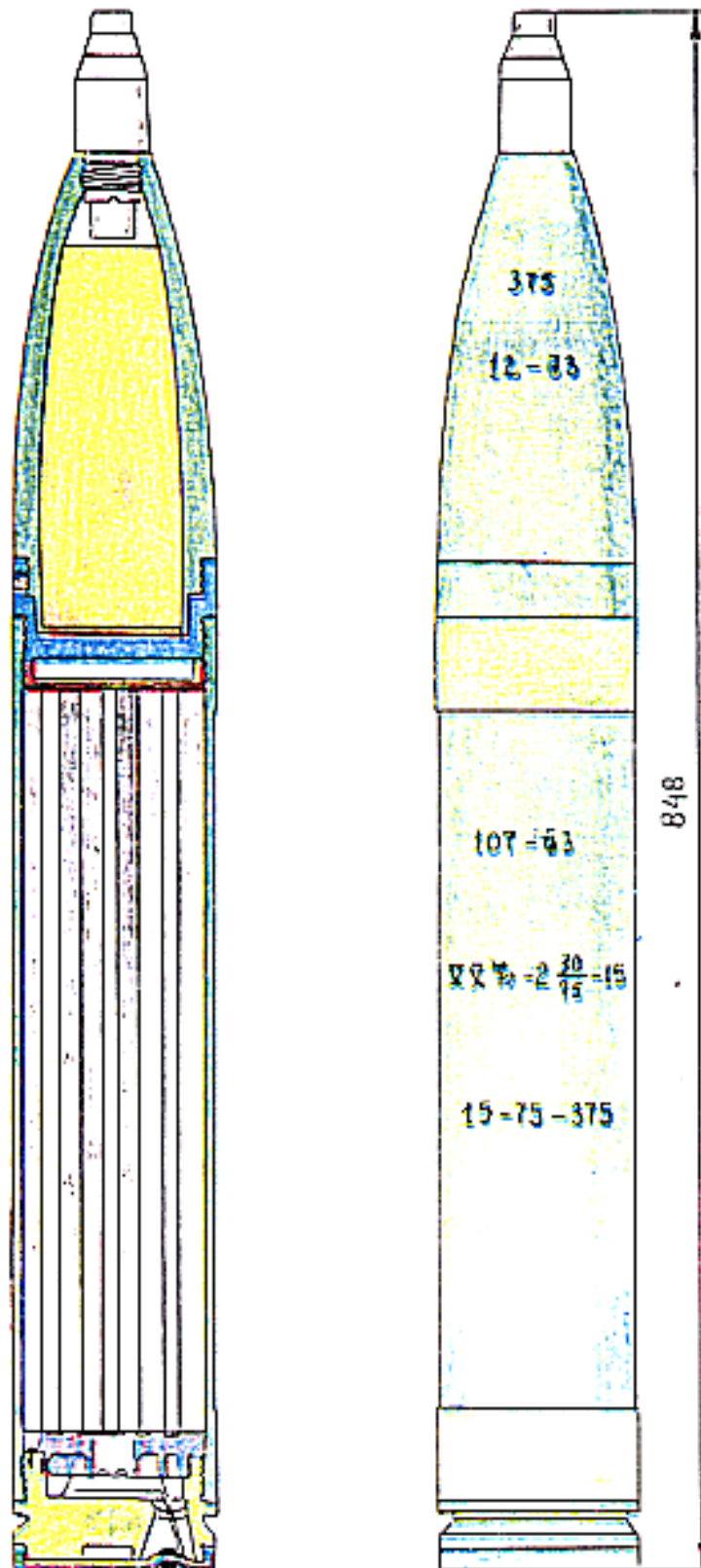

Figure 6-1. HE-fragmentation rocket for 107 mm. rocket launcher model 63 with primer adjacent to turbine.

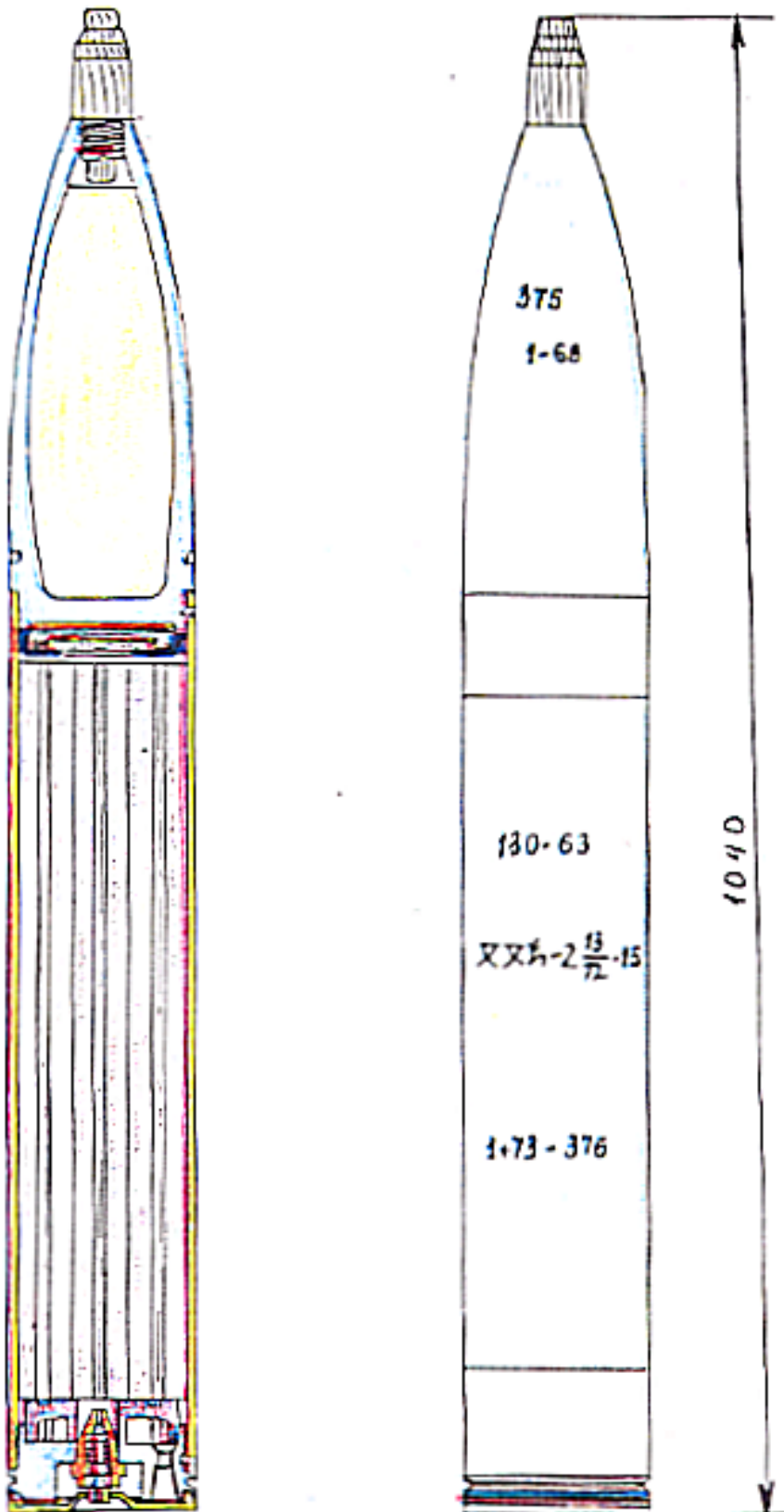

Figure 6-4 HE-fragmentation rocket for 130 mm. rocket launcher model 63.

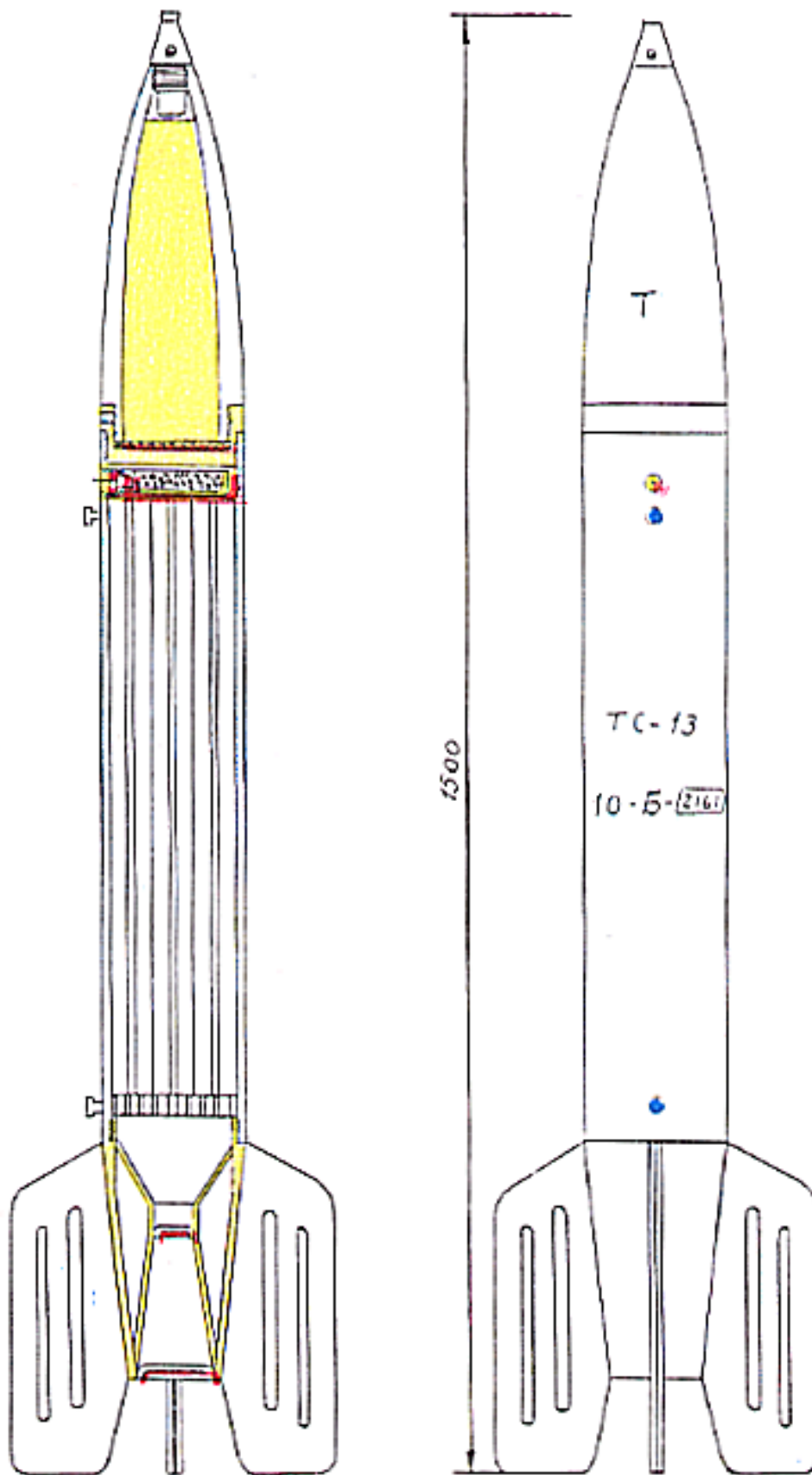

Figure 6-5 HE-fragmentation rocket for 130 mm. ML-13 launcher.

PART VII

DRAWINGS OF SMALL-ARMS MUNITIONS

Pages 297 and 298 are presumably blank. [IN ORIGINAL]

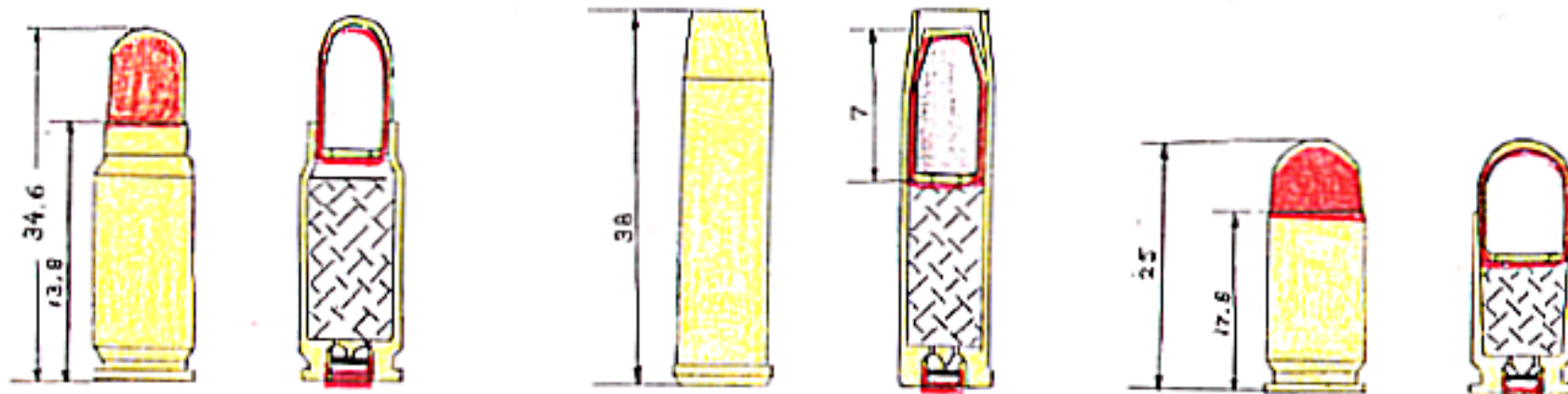

Figure 7-1 7.62 mm. round for pistol and automatic rifle model 54.

Figure 7-2 7.62 mm. round for Nagant revolver.

Figure 7-3 9 mm. round for pistol model 1959.

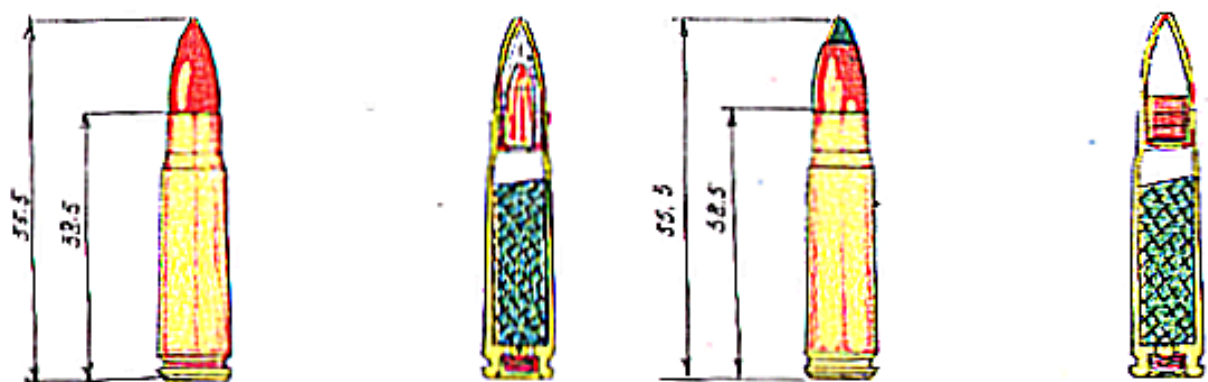

Figure 7-4 7.62 round with standard bullet

Figure 7-5 7.62 bullet with tracer bullet.

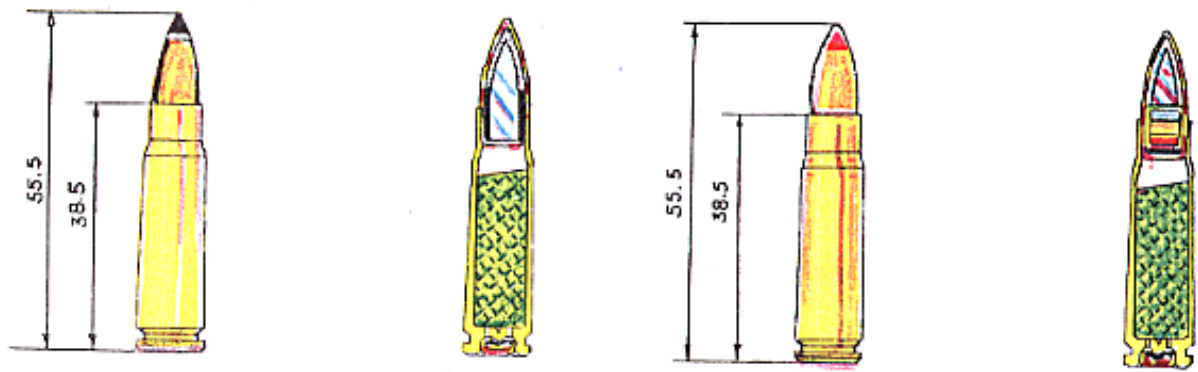

Figure 7-6 7.62 round model 56 with AP- incendiary bullet.

Figure 7-7 7.62 round model 56 with incendiary bullet.

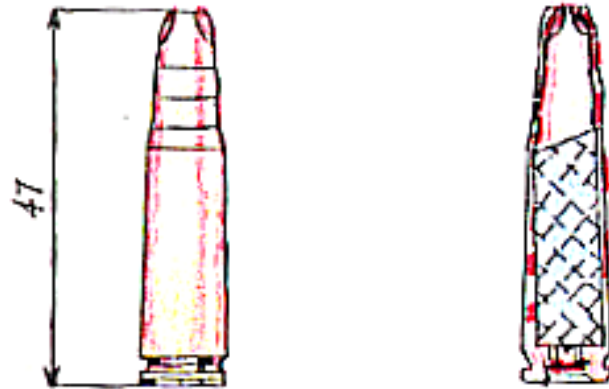

Figure 7-8 7.62 exercise [BLANK] round model 56.

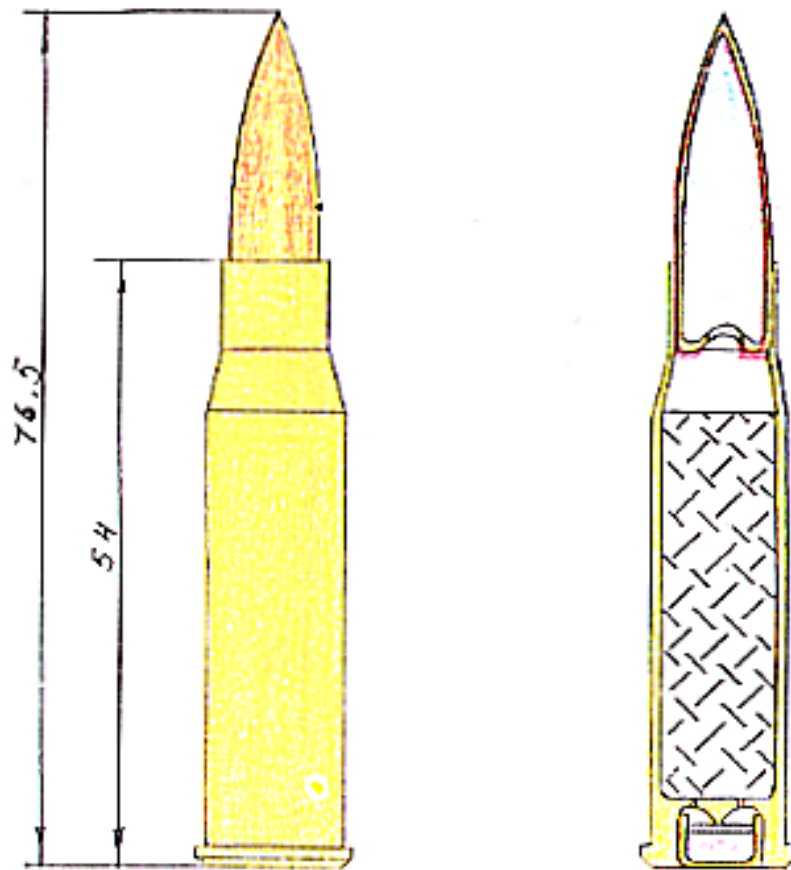

Figure 7-9 7.62 round model 53 with lightweight bullet.

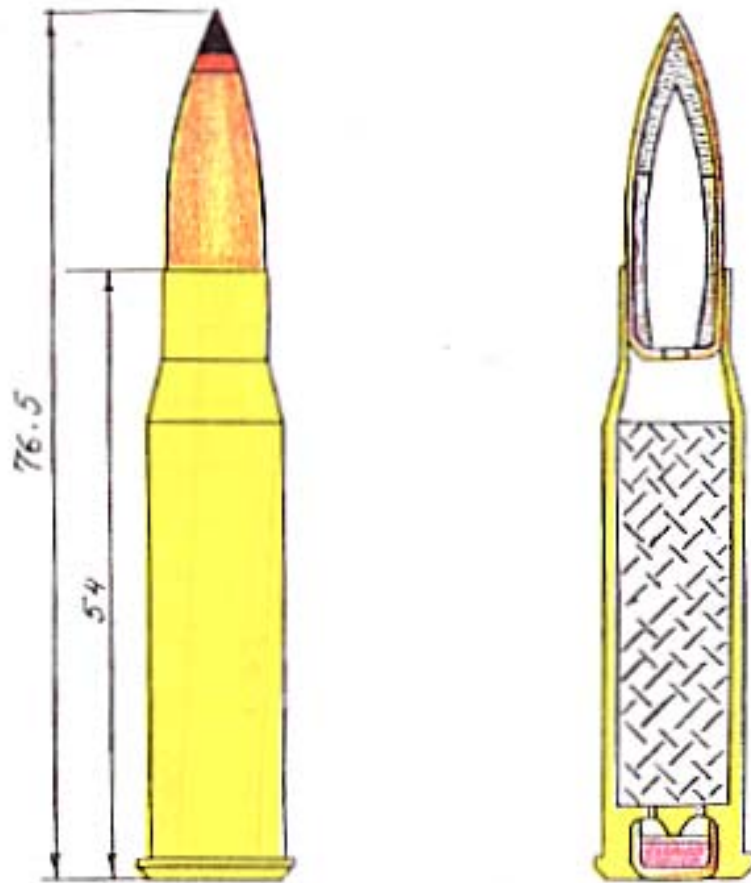

Figure 7-11 7.62 round model 53 with AP-incendiary bullet.

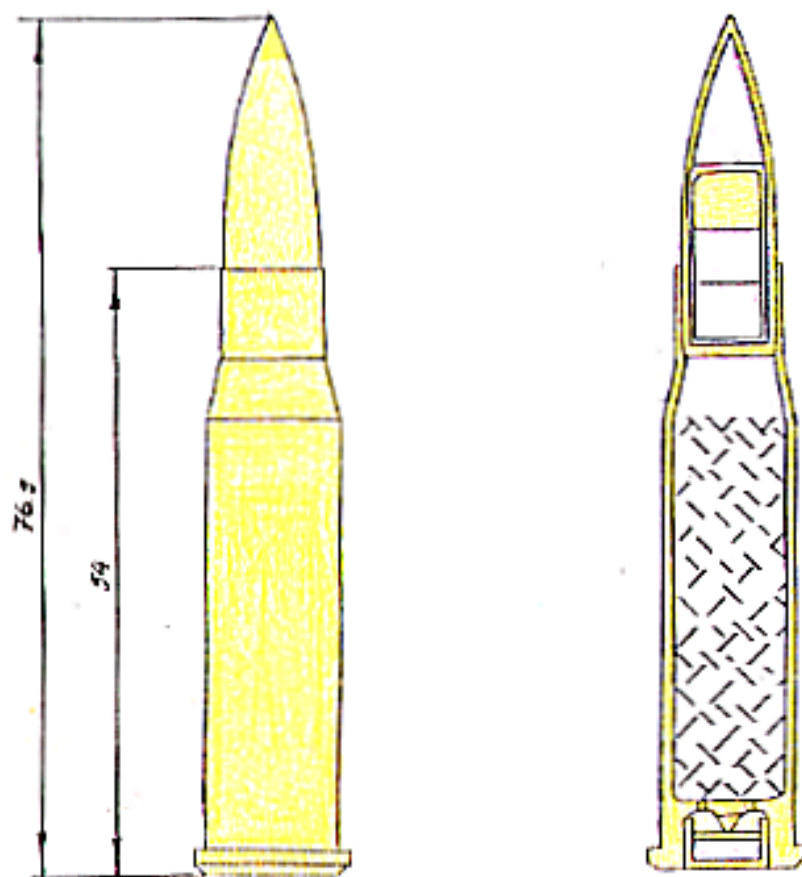

Figure 7-12 7.62 round model 53 with tracer bullet.

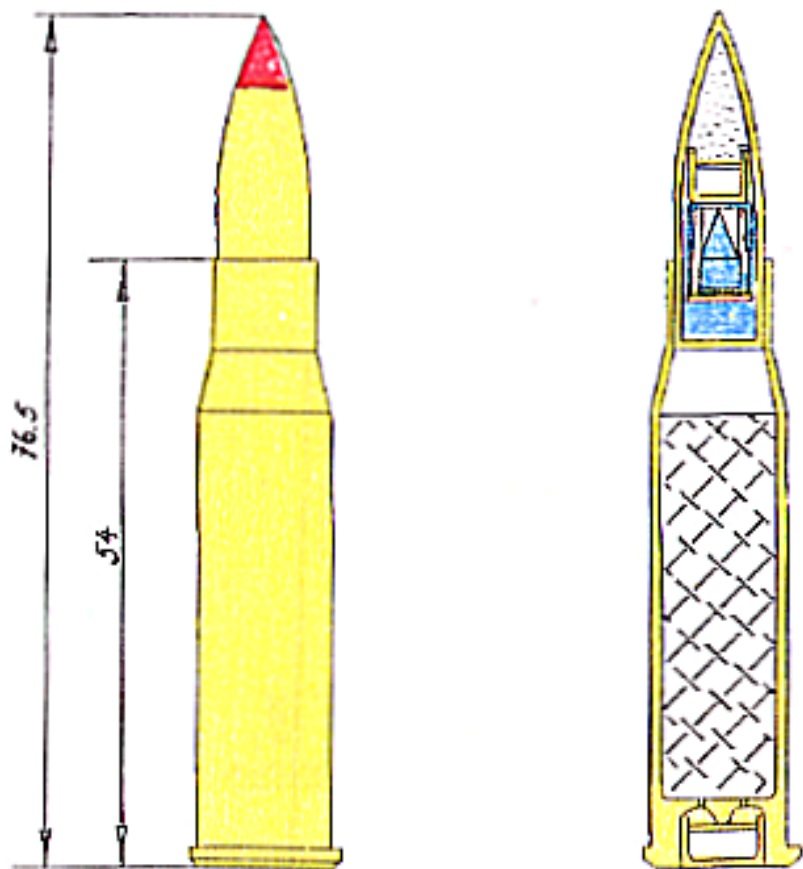

Figure 7-13 7.62 round model 53 with incendiary tracer bullet.

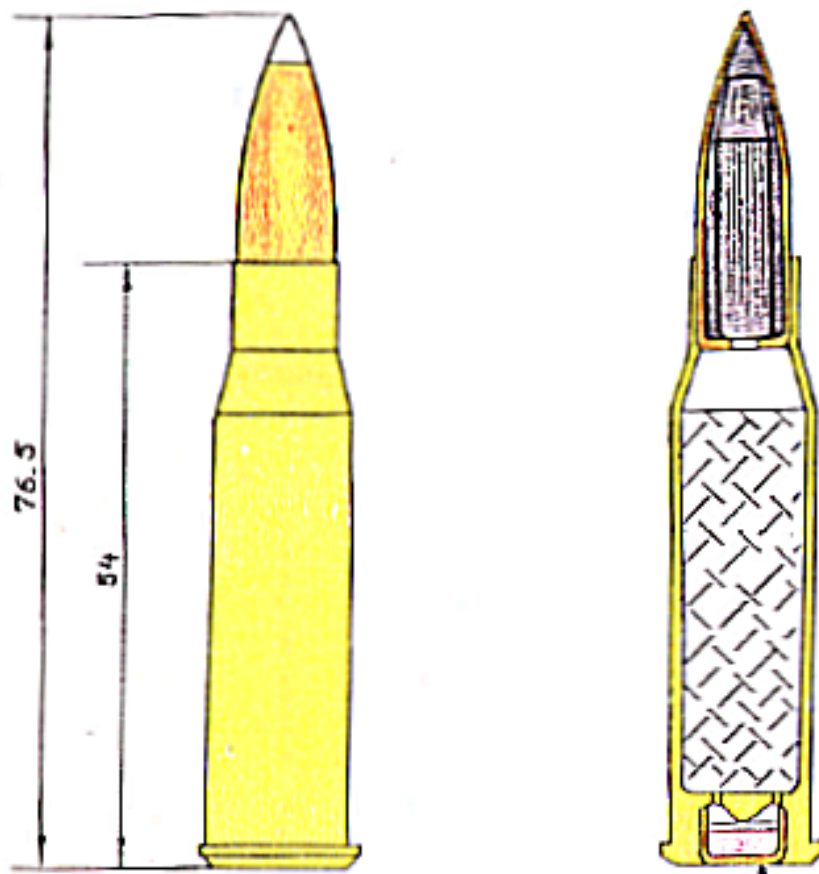

Figure 7-14 Model 53 round with lightweight bullet with steel core.

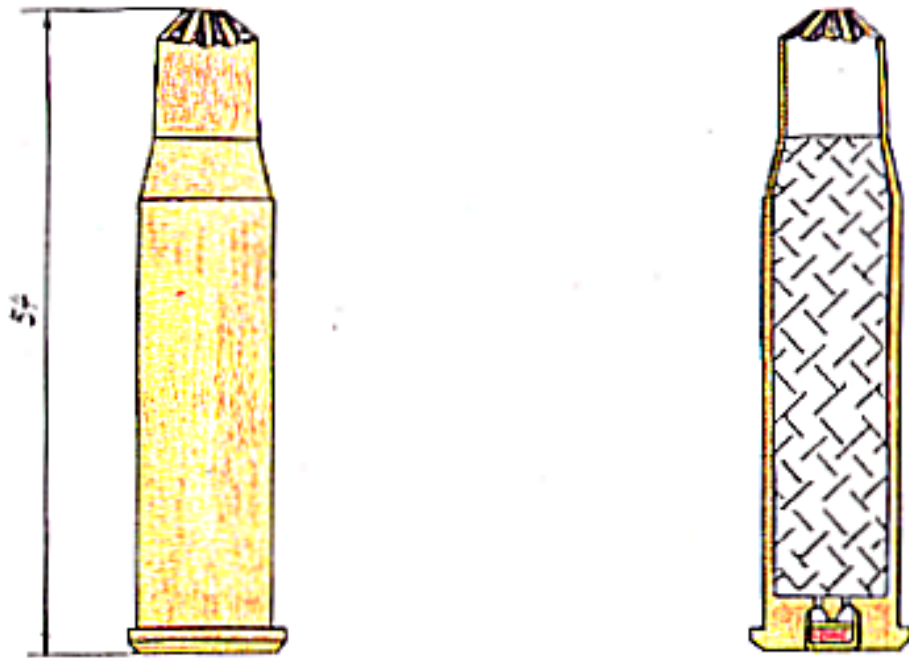

Figure 7-15 7.62 mm. Exercise [BLANK] round model 53.

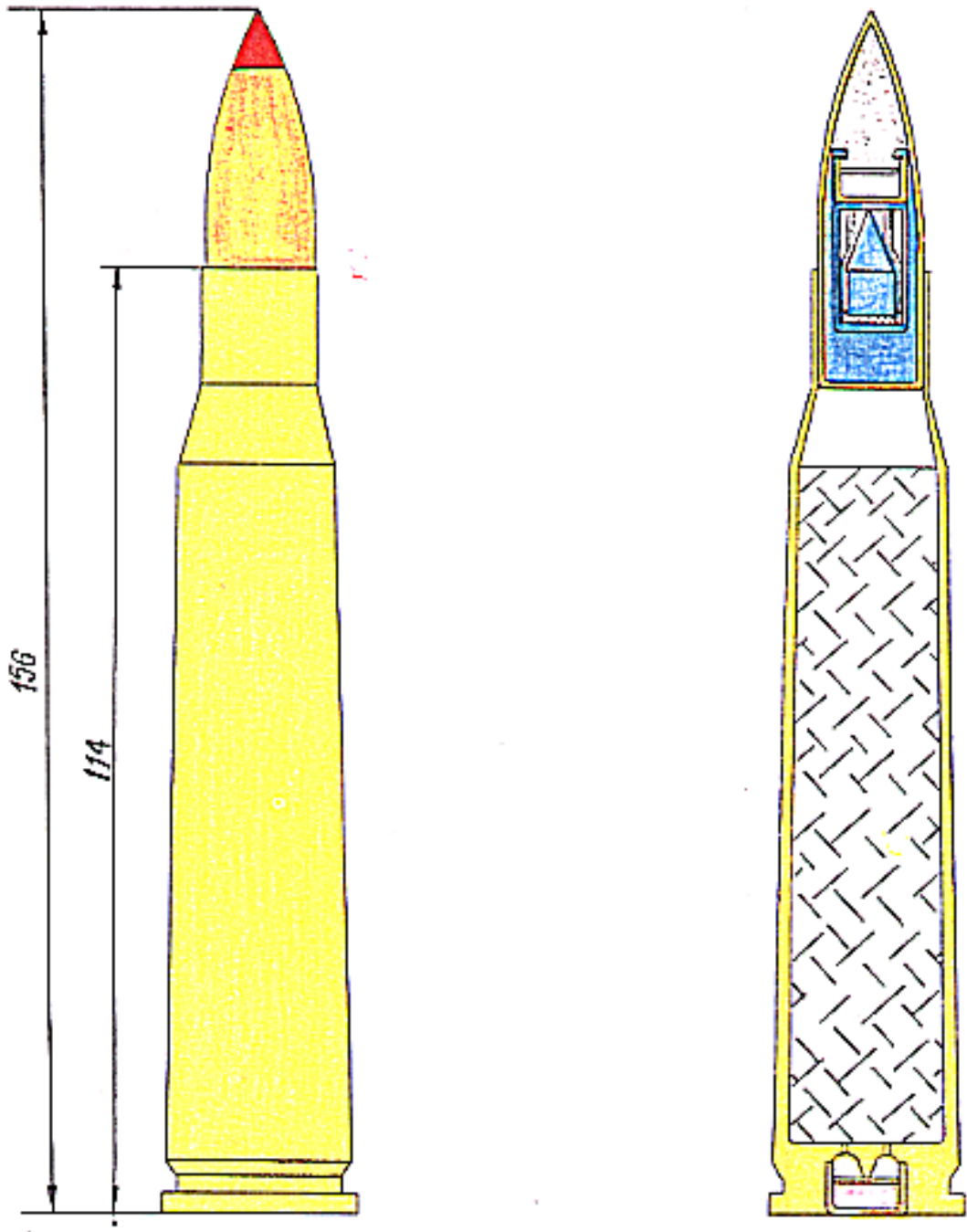

Figure 7-16 12.7 mm. round with AP-incendiary bullet.

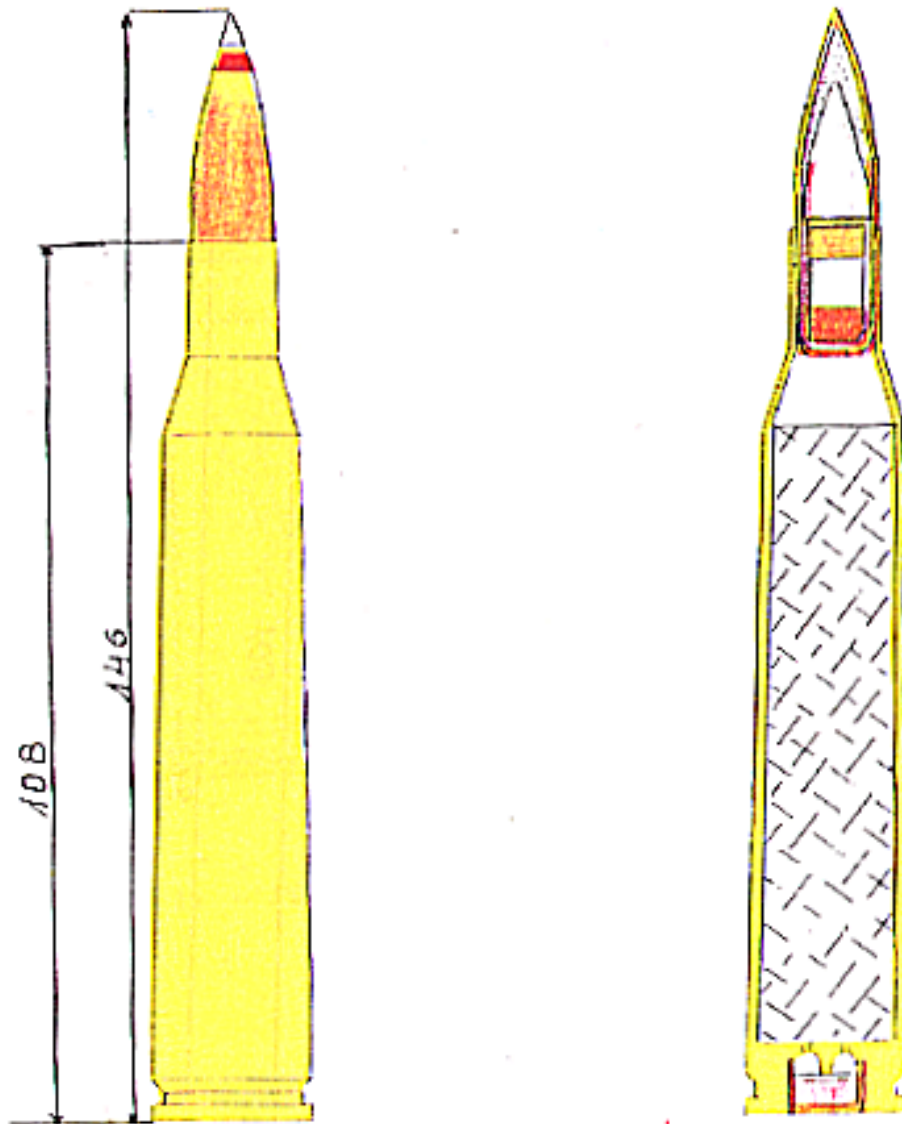

Figure 7-17 12.7 mm. round with AP-incendiary-tracer bullet.

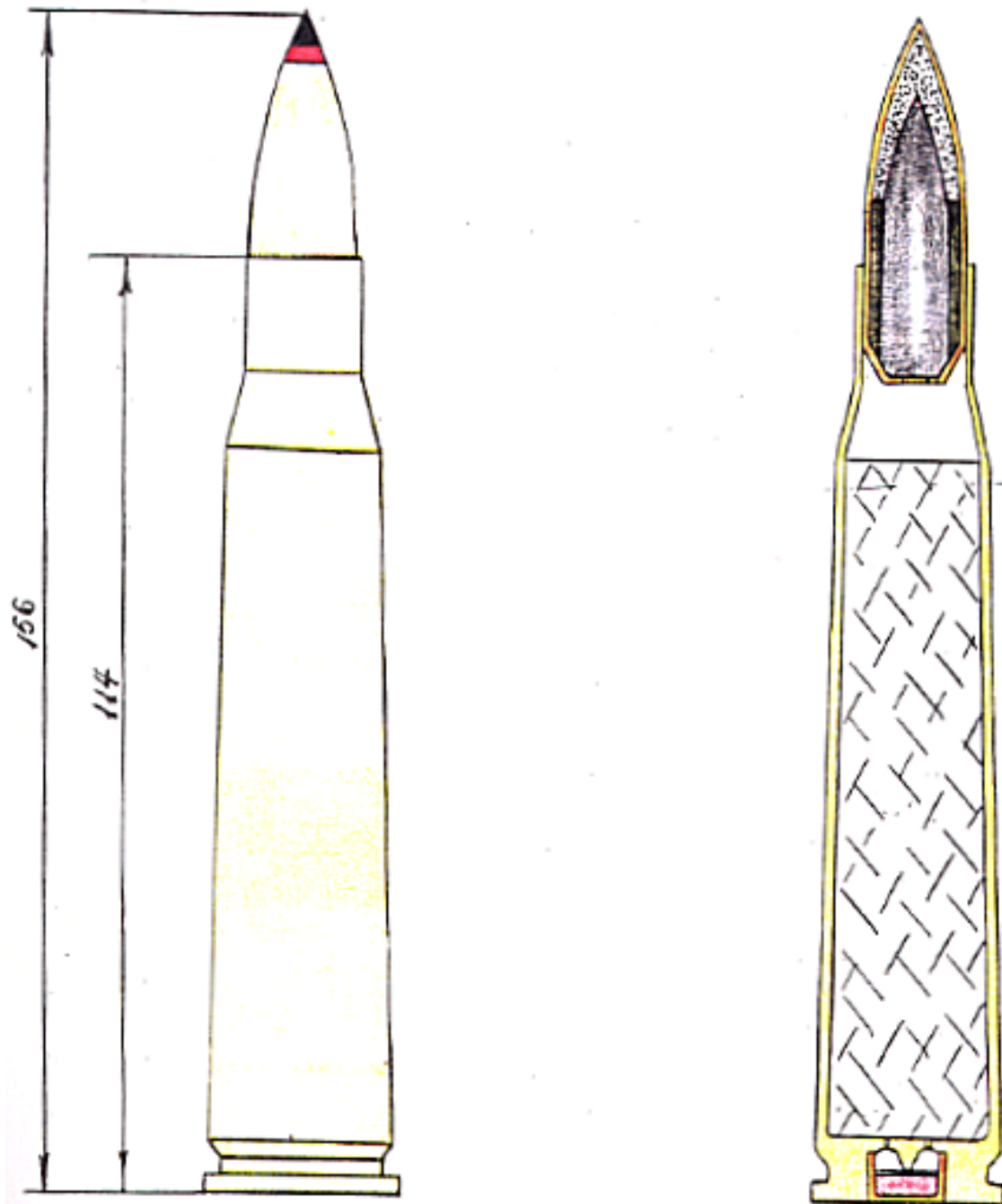

Figure 7-18 14.5 mm. round with AP-incendiary bullet.

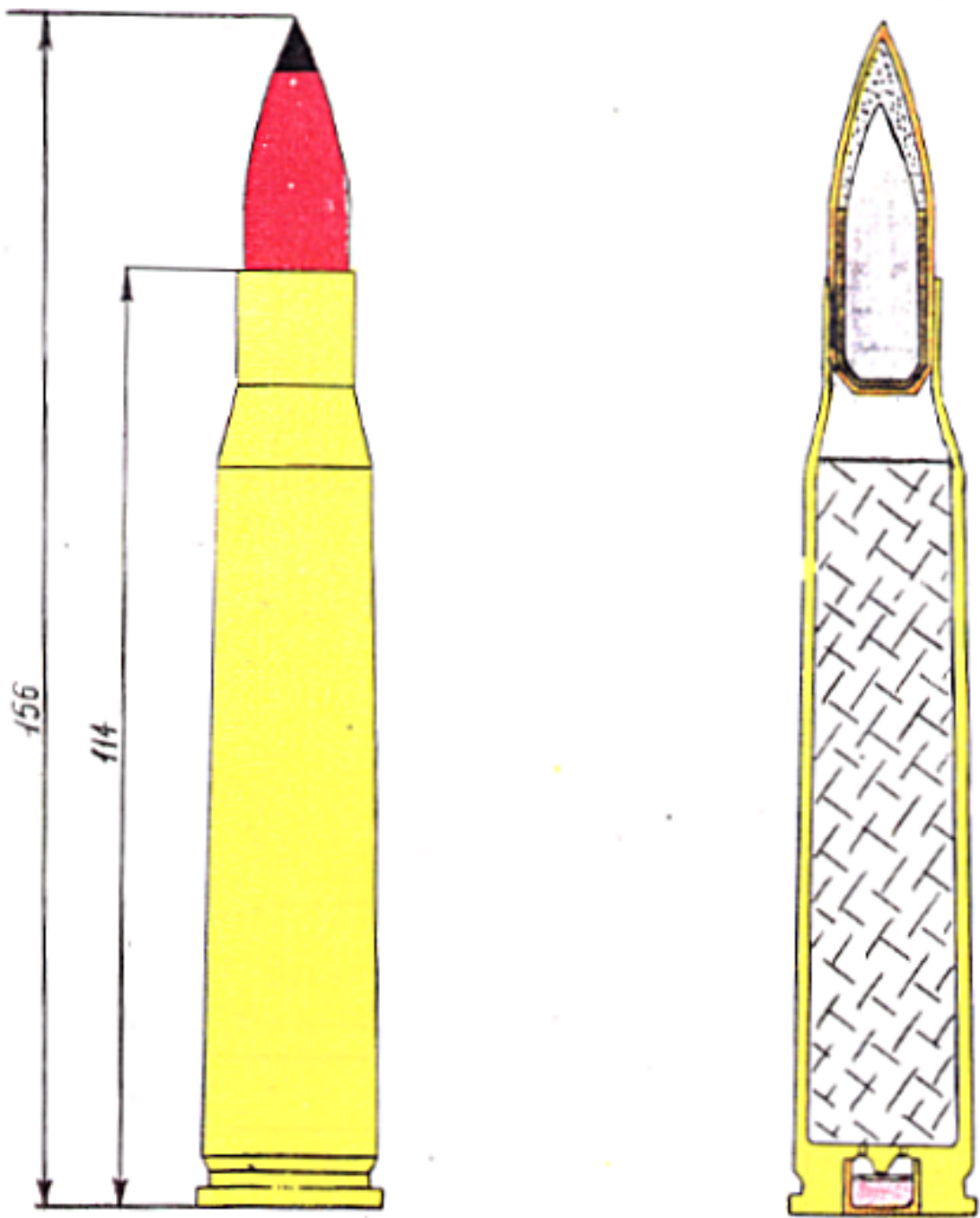

Figure 7-19 14.5 mm. round with AP-incendiary bullet with special core.

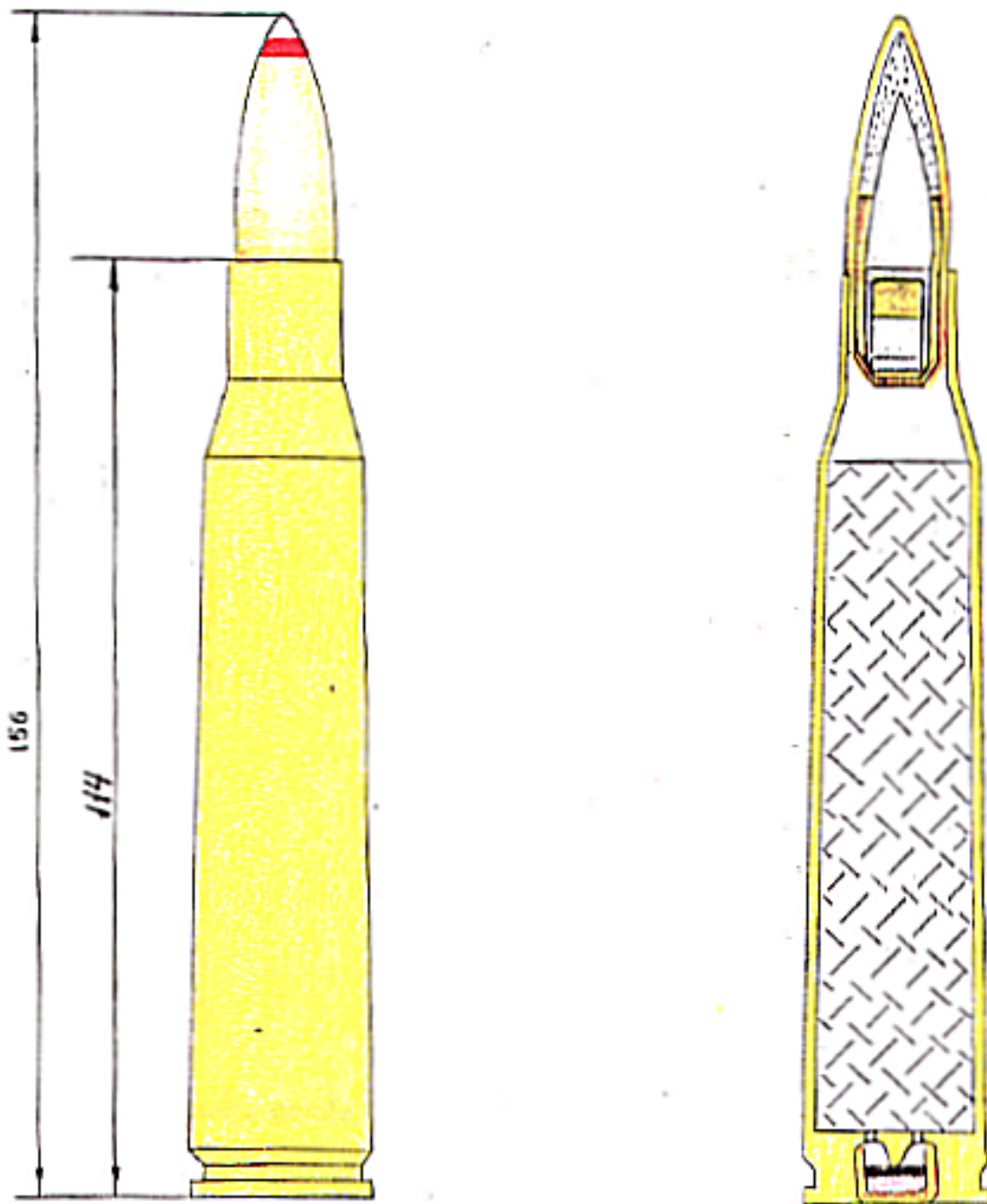

Figure 7-20 14.5 mm. round with AP-incendiary-tracer bullet.

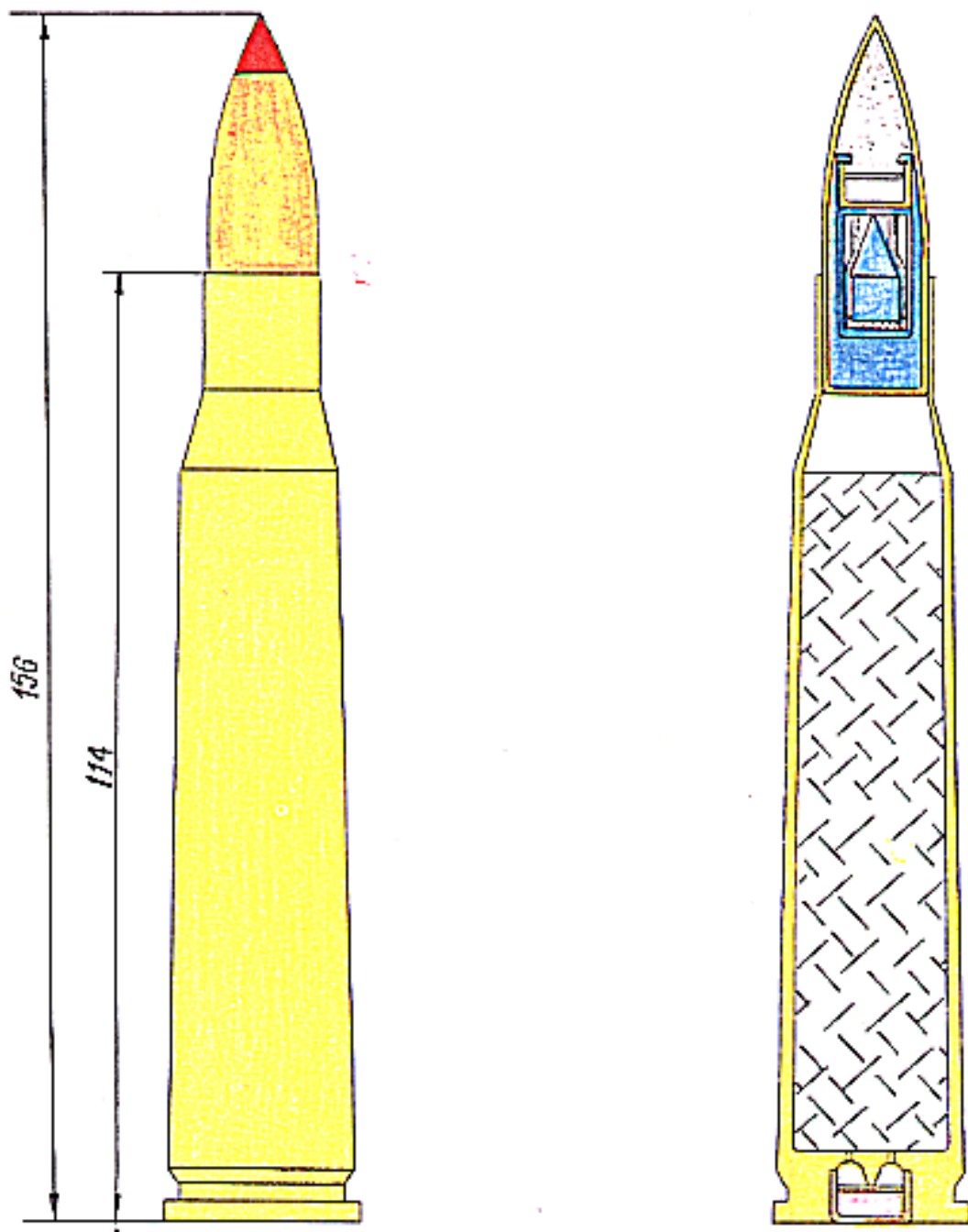

Figure 7-21 14.5 mm. round with incendiary bullet.

PART VIII

DRAWINGS OF HAND GRENADES

Pages 317 and 318 are presumably blank. [IN ORIGINAL]

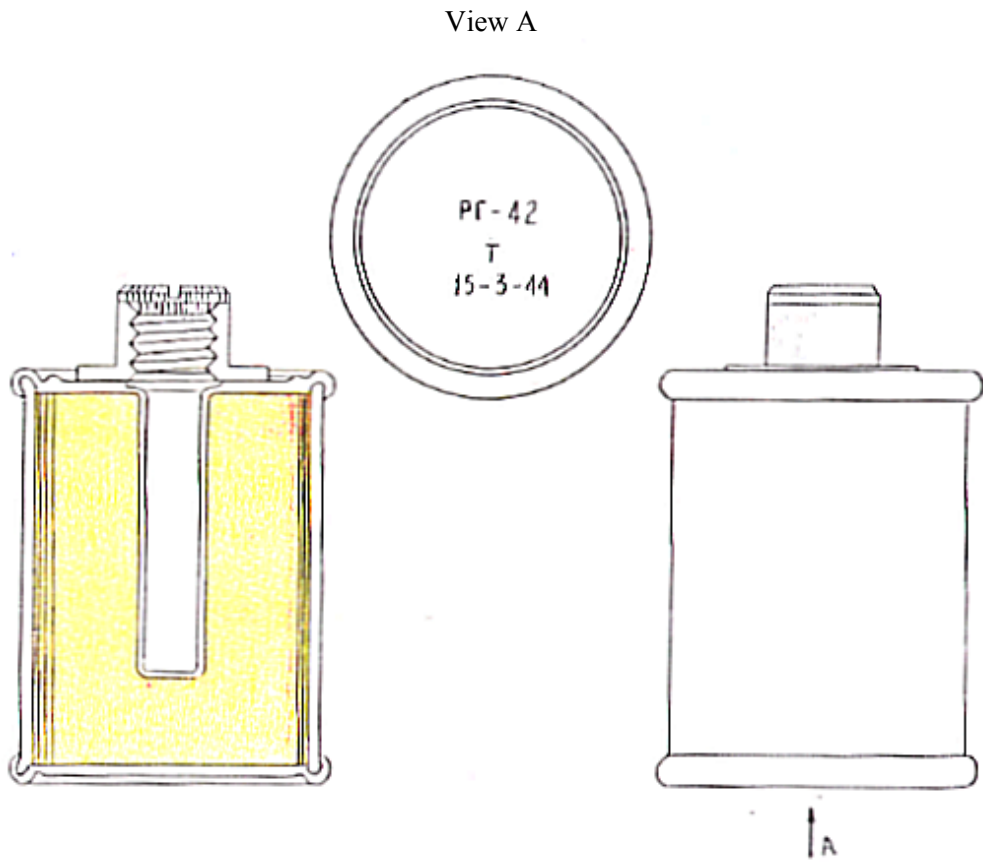

Figure 8-1 Assault hand grenade model 42.

View A

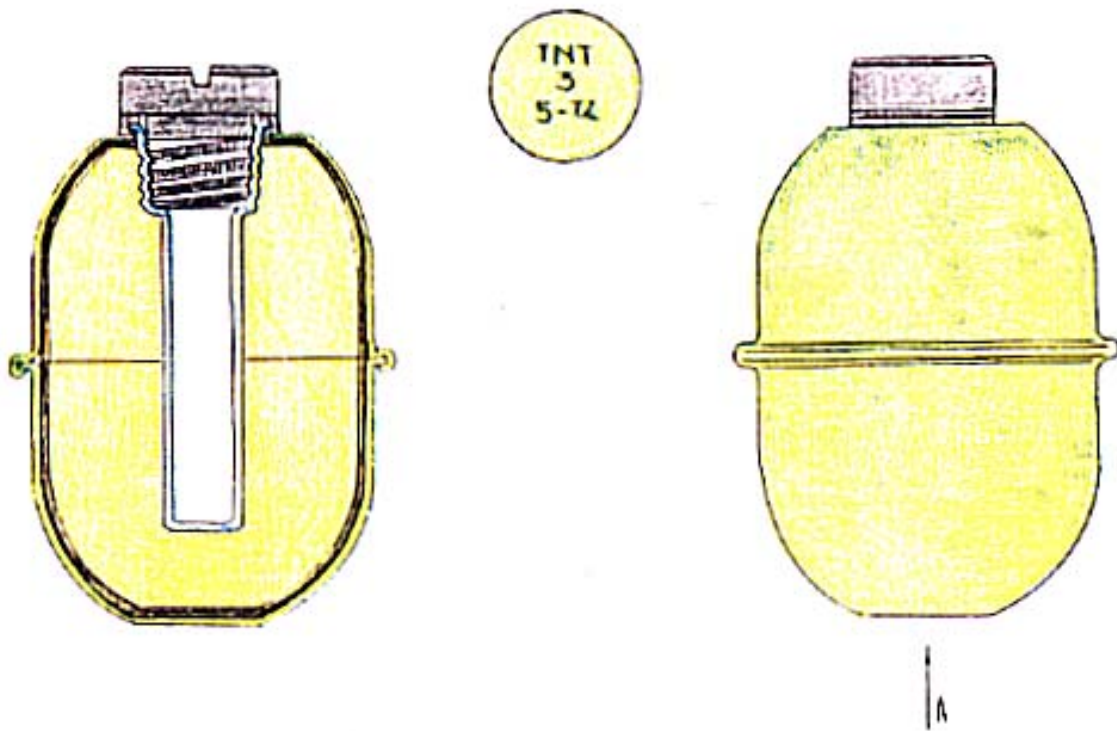

Figure 8-2 Assault hand grenade model 59.

View A.

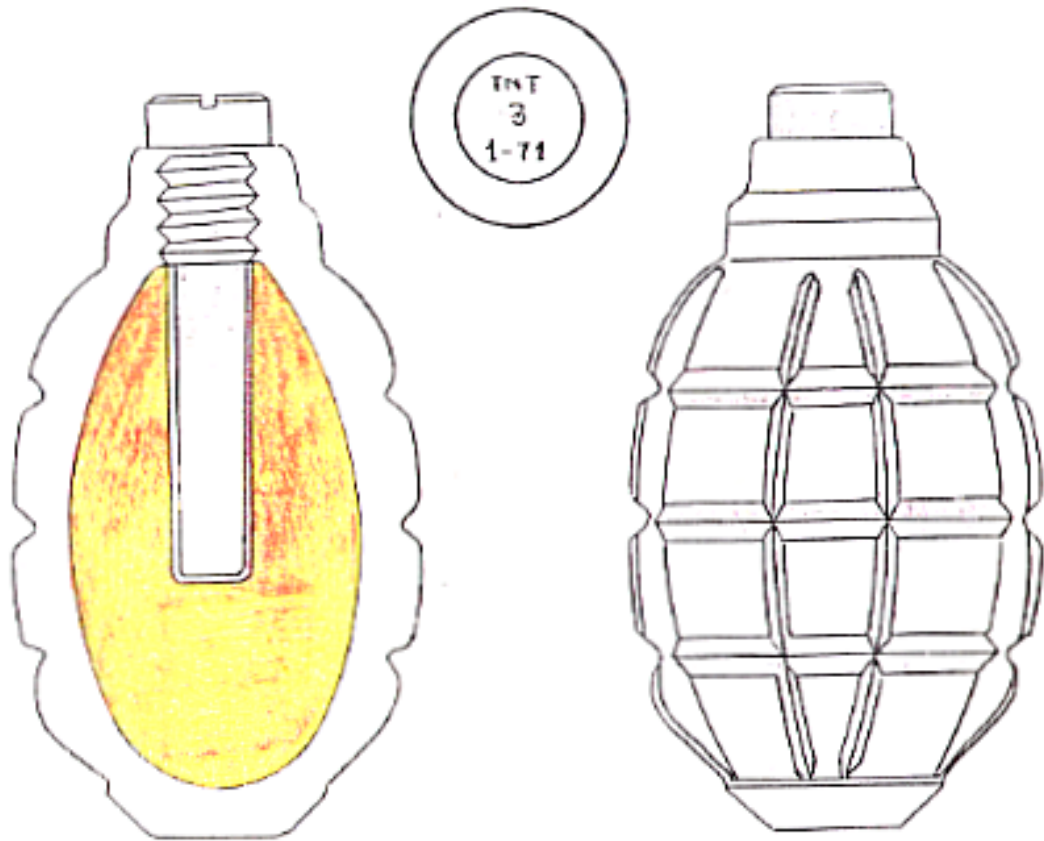
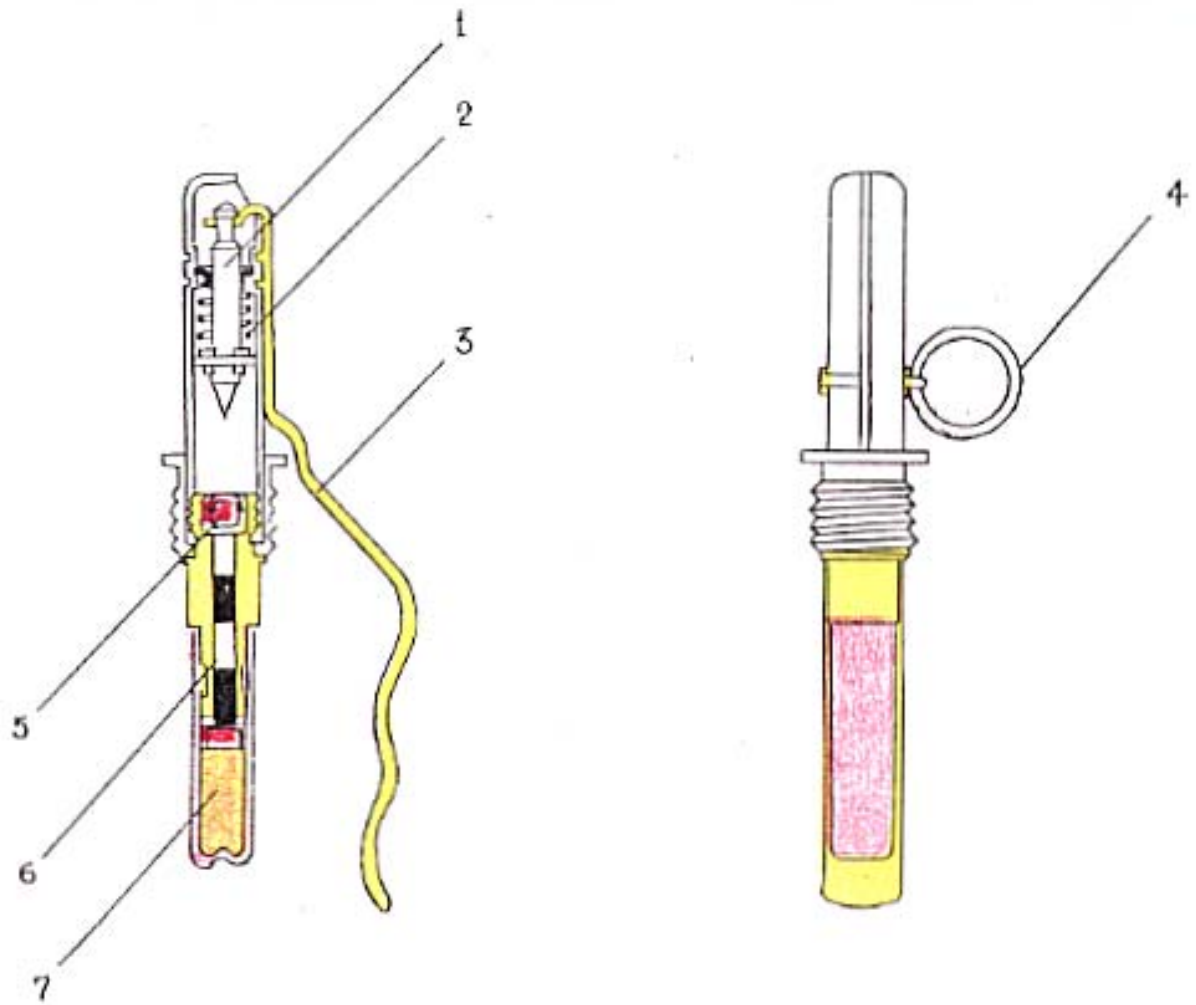
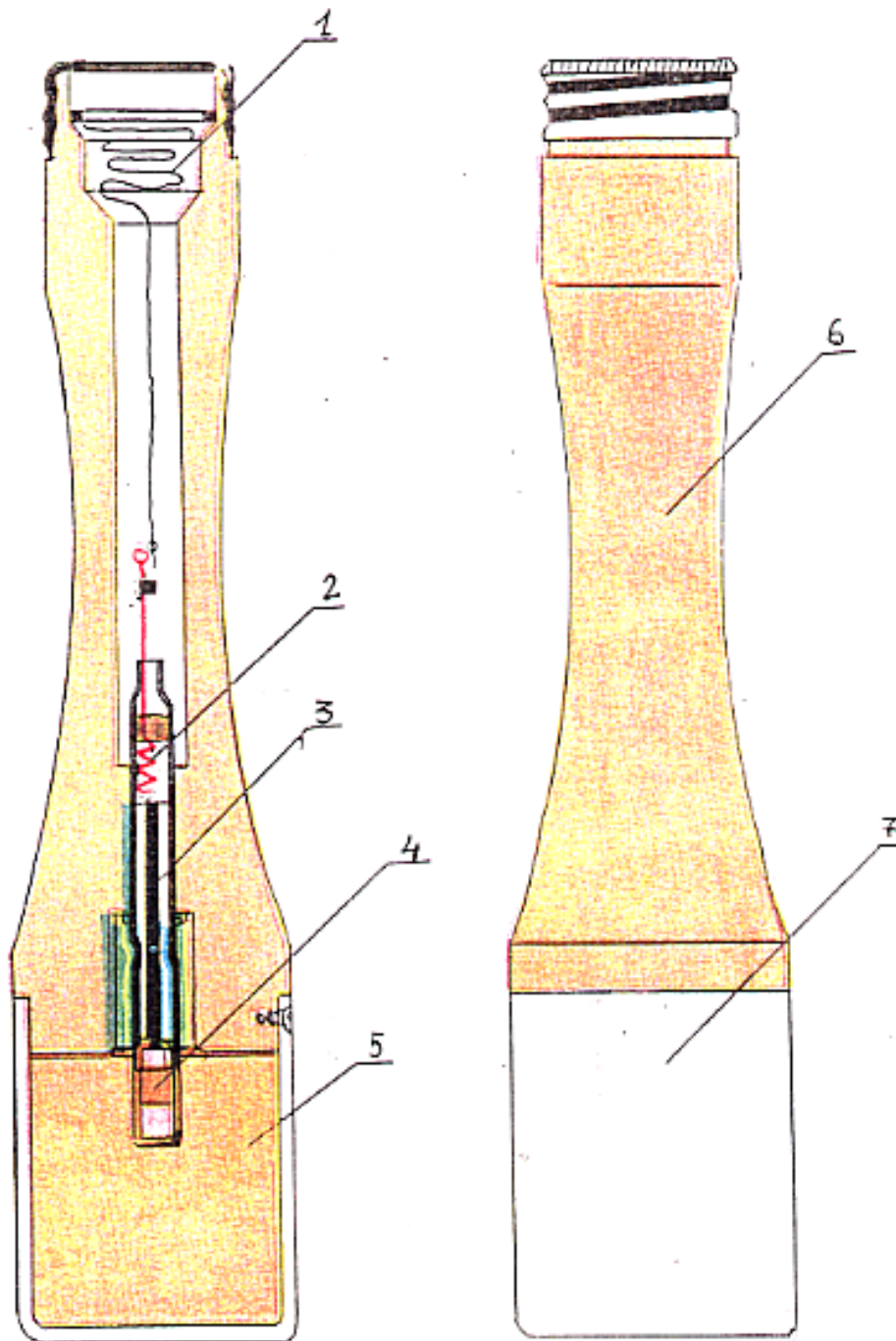

Figure 8-3 Defensive hand grenade.



- | | | | |
|----|---------------------|----|--------------------|
| 1. | Firing pin. | 5. | Primer capsule. |
| 2. | Firing pin springs. | 6. | Retardant. |
| 3. | Handle. | 7. | Detonator capsule. |
| 4. | Securing pin. | | |

Figure 8-4 Design of the one-piece primer for hand grenades (This primer is used in the assault hand grenades models 42 and 59, and in the defensive grenade model F-1.)



- | | | | |
|----|--------------------|----|---------------|
| 1. | Pull-cord. | 5. | Explosive. |
| 2. | Friction igniter. | 6. | Grenade body. |
| 3. | Retardant. | 7. | Wooden stick. |
| 4. | Detonator capsule. | | |

Figure 8-5 Assault hand grenade with wooden stick.

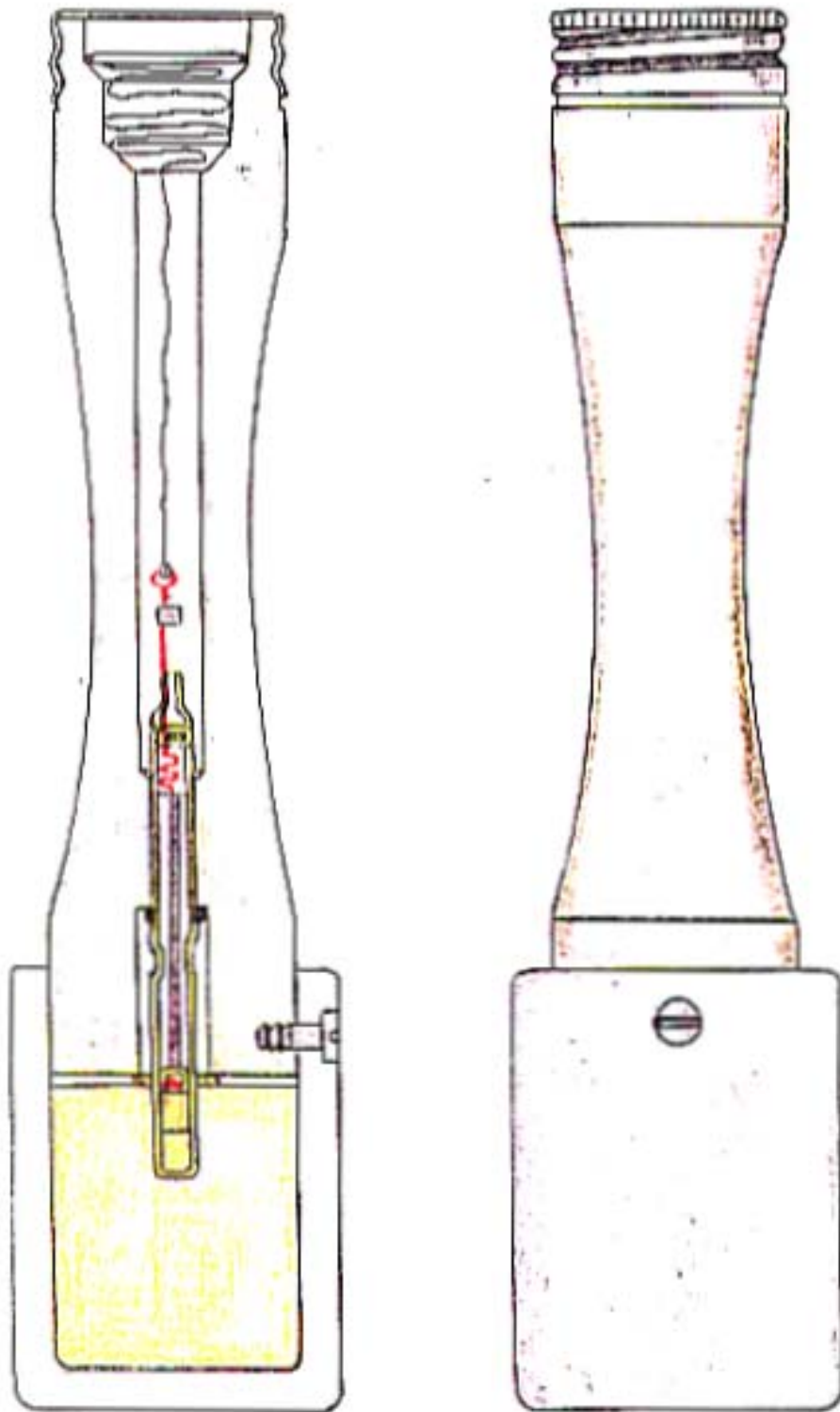
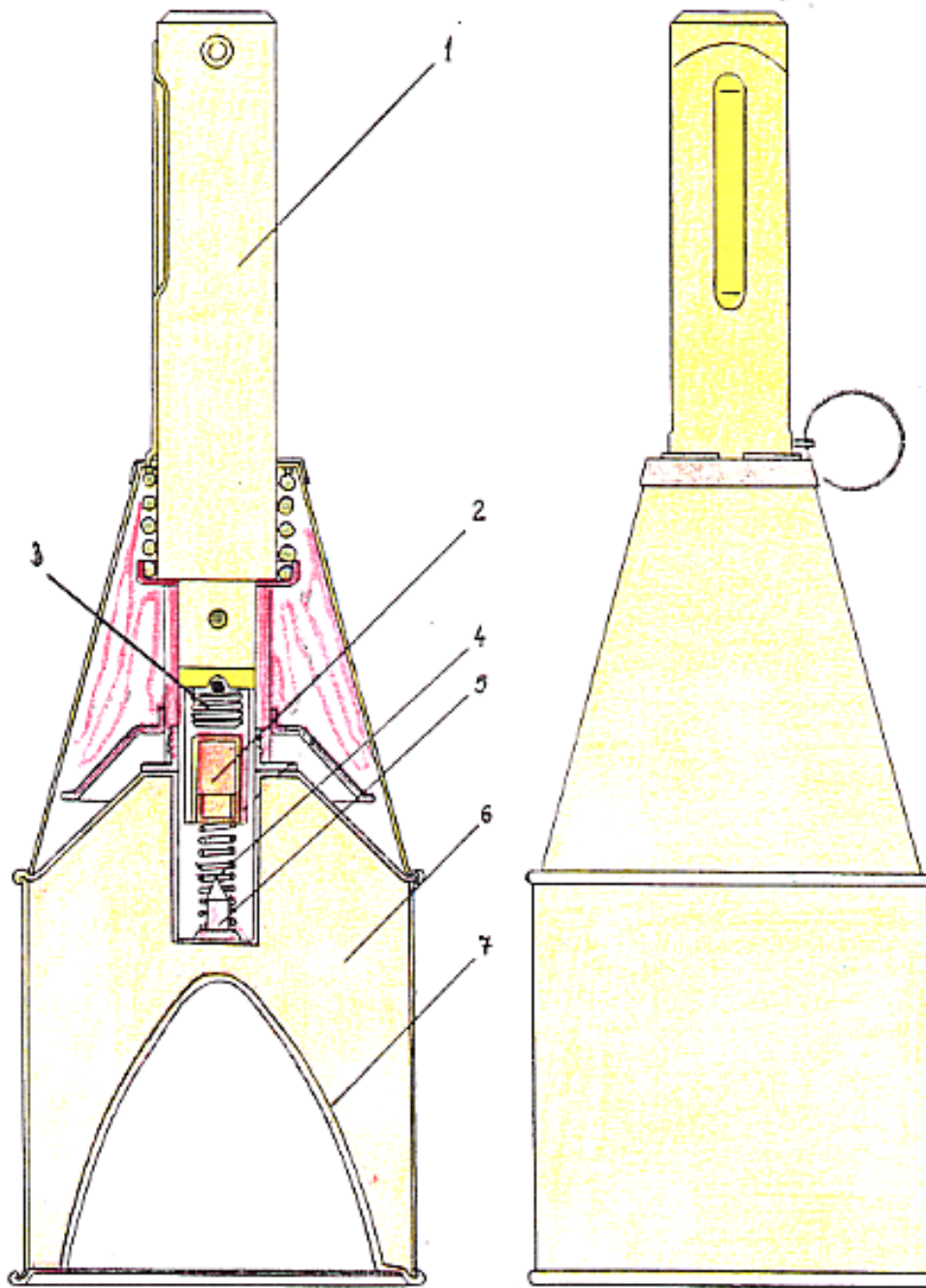

Figure 8-6. Assault Hand Grenade with wooden stick



- | | | | |
|----|--------------------|----|----------------|
| 1. | Handle. | 5. | Firing pin. |
| 2. | Primer. | 6. | Explosive. |
| 3. | Retaining device. | 7. | Hollow funnel. |
| 4. | Firing-pin spring. | | |

Note: To prepare the grenade for launching, the primer is screwed in as far as the end of the retaining device in the handle.

Figure 8-7 Anti-tank hand grenade model 43.

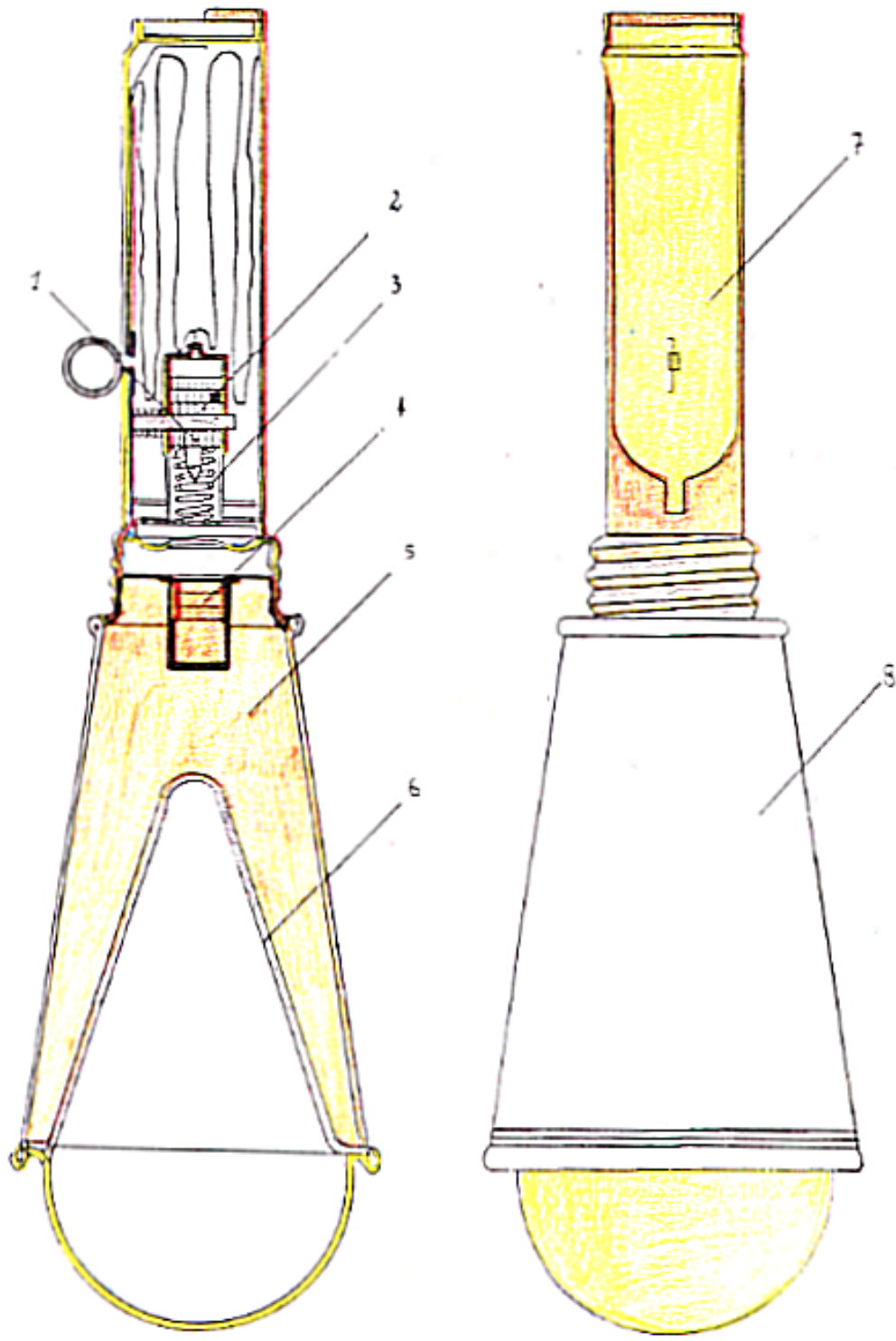

- | | | | |
|----|-----------------------------|----|----------------|
| 1. | Firing pin. | 5. | Explosive. |
| 2. | Firing pin support shaft. | 6. | Hollow funnel. |
| 3. | Firing pin spring. | 7. | Handle. |
| 4. | Primer (detonator capsule.) | 8. | Grenade body. |

Note: (illegible except for "the primer is inserted.")

Figure 8-8 **Anti-tank hand grenade model 6.**

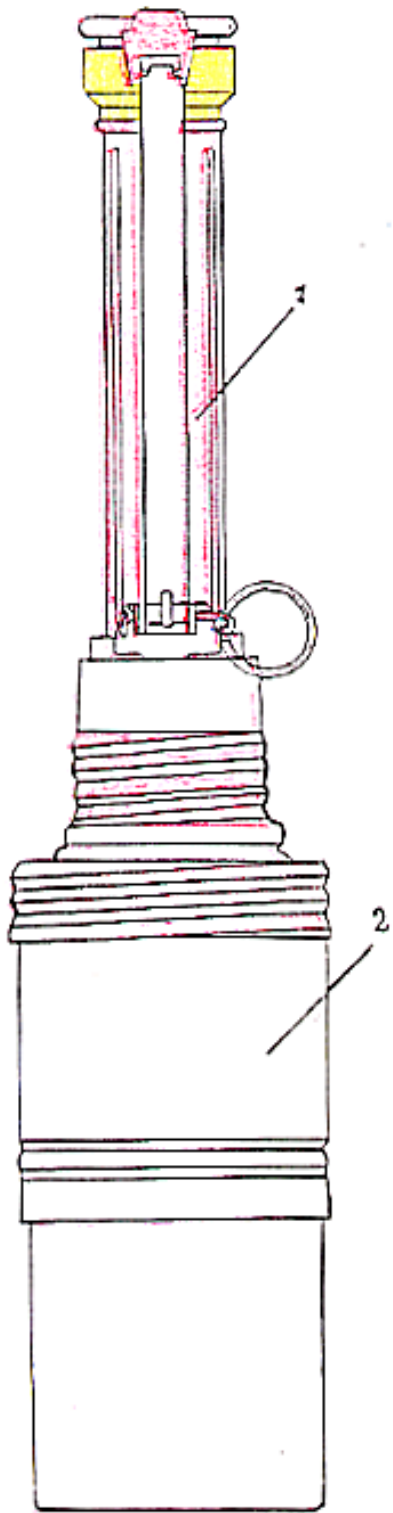

1. Handle.

2. Grenade body.

Note: To prepare the grenade for throwing the detonator capsule is placed in the aperture in the body of the grenade.

Figure 8-9 Anti-tank hand grenade model 3 (external view.)

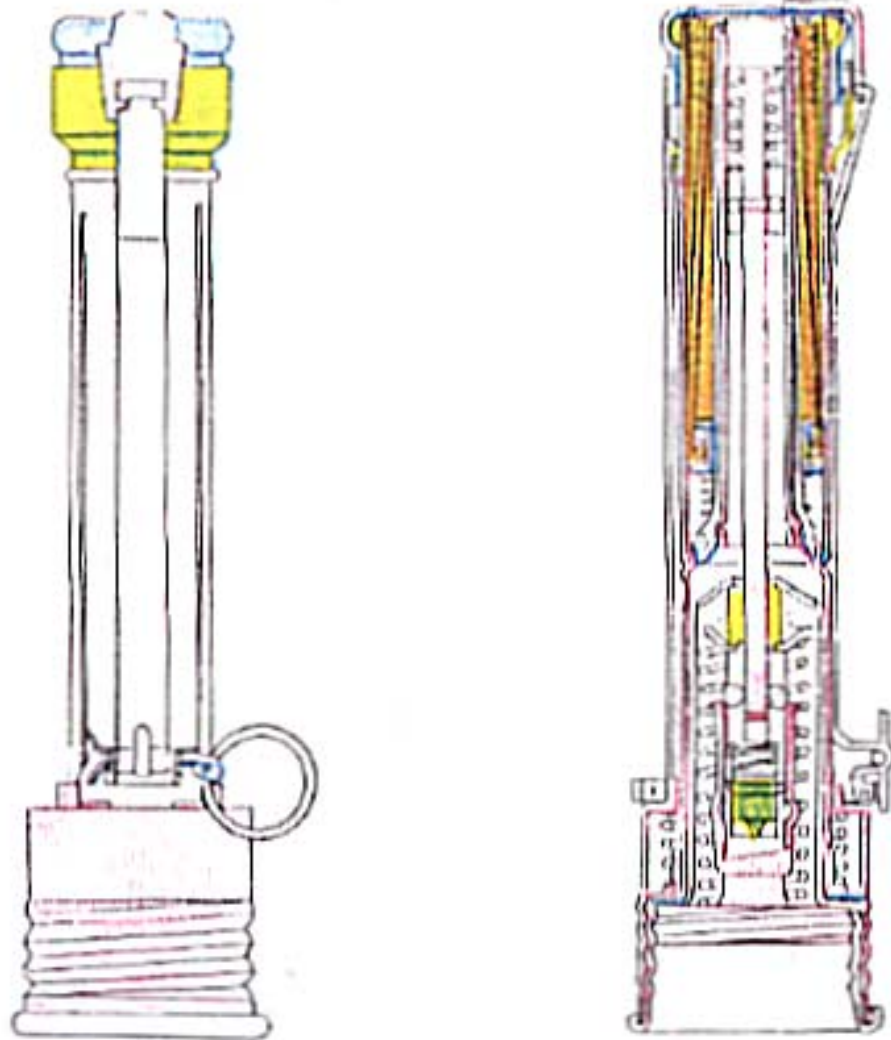
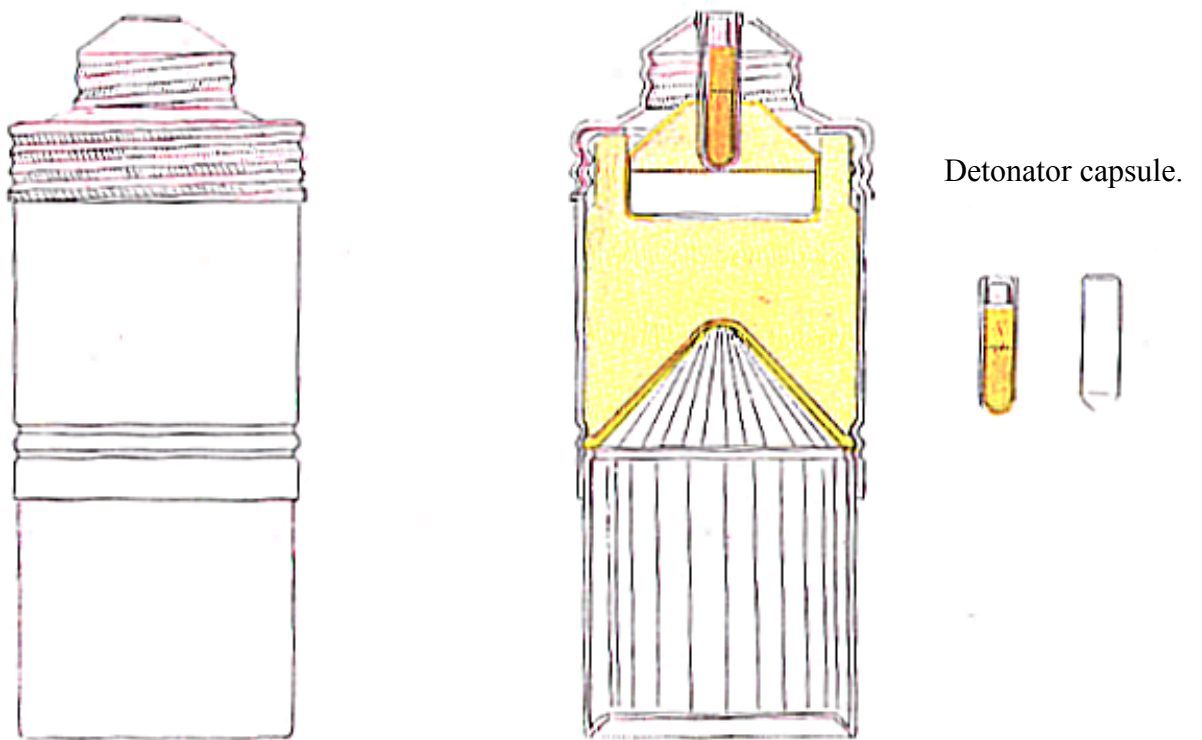

Figure 8-10 Handle of anti-tank hand grenade model 3.



Note: To prepare the grenade for throwing the detonator capsule is placed in the aperture in the body of the grenade.

Figure 8-11 Body of anti-tank hand grenade model 3.

PART IX

DRAWINGS OF SIGNAL AND ILLUMINATING ROUNDS

Pages 331 and 332 are presumably not printed.[IN ORIGINAL]

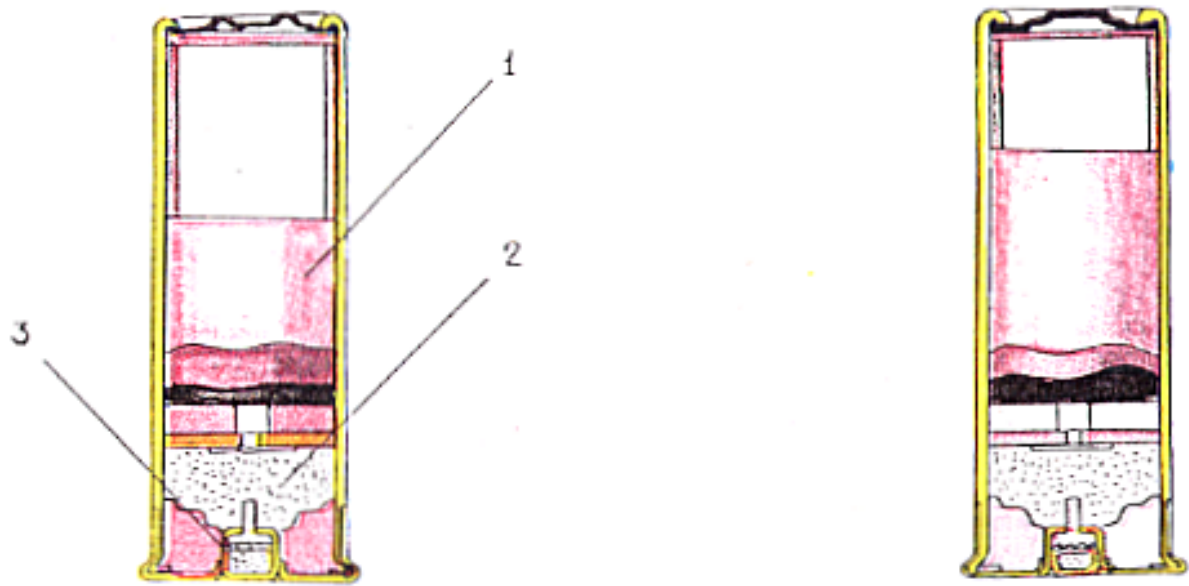

1. Signalling charge.
2. Gunpowder with smoke.
3. Primer capsule for gunpowder.

Figure 9-1 Design of 26 mm. night signalling round.

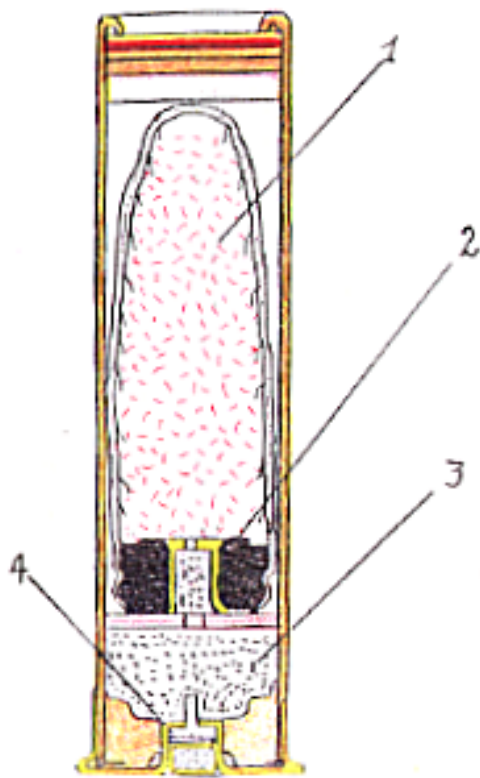

1. Signalling charge.
2. Retardant.
3. Gunpowder with smoke.
4. Primer capsule for gunpowder.

Figure 9-2 Design of 26 mm. daylight signalling round.

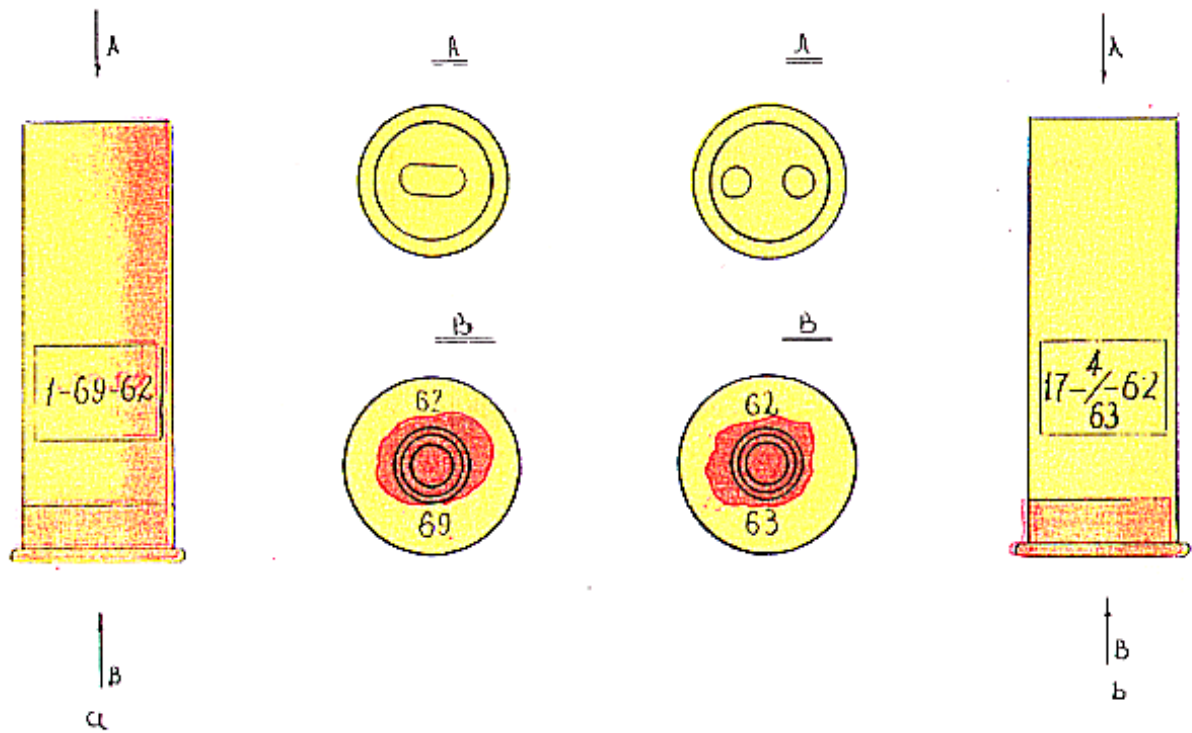

a. Yellow.

b. Green.

Figure 9-3 26 mm. night signalling rounds.

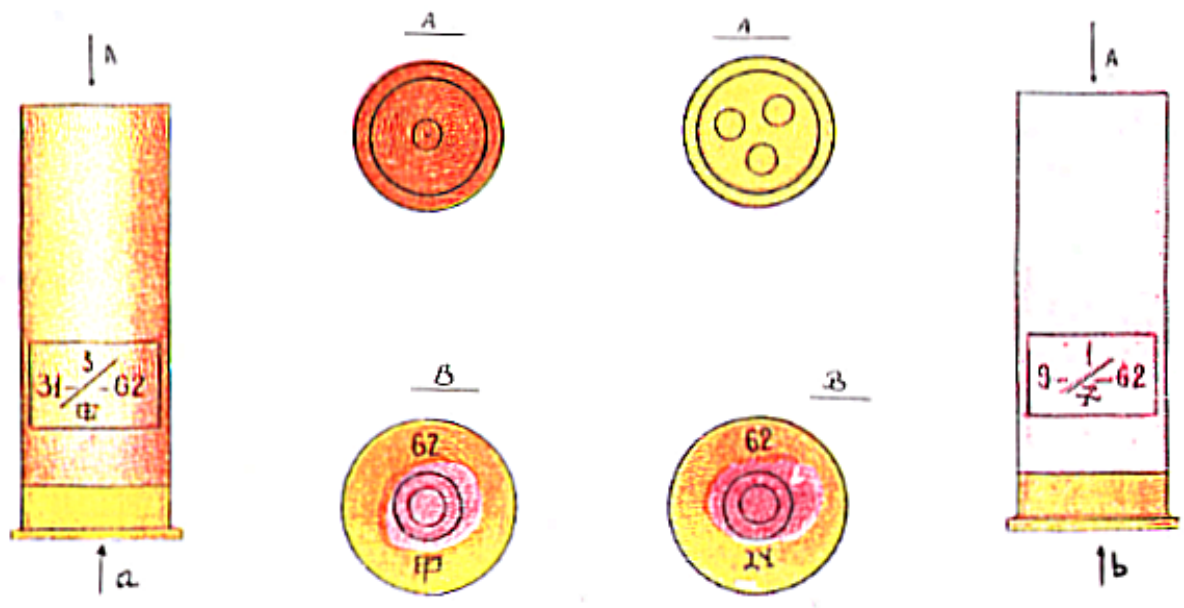

a. Red. b. White (illuminating).

Figure 9-4 26 mm. night signalling rounds.

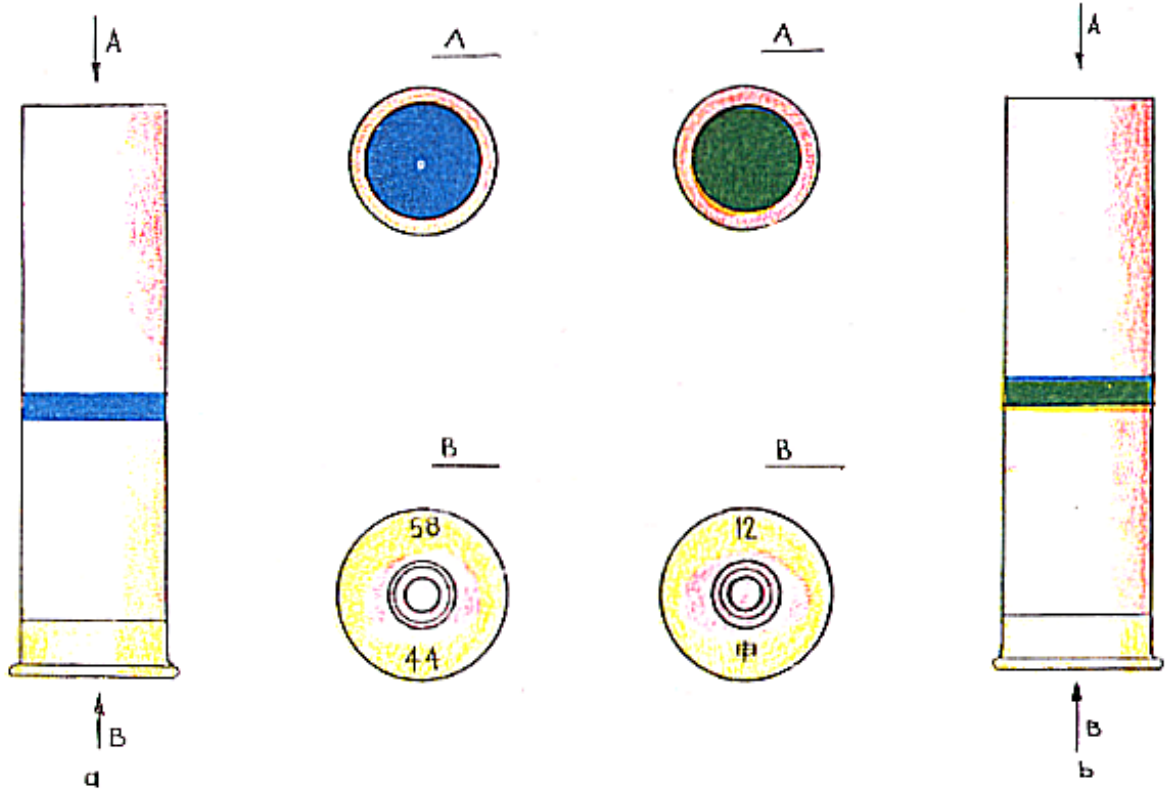

a. Blue.

b. Green.

Figure 9-5 26 mm. daylight signalling round.

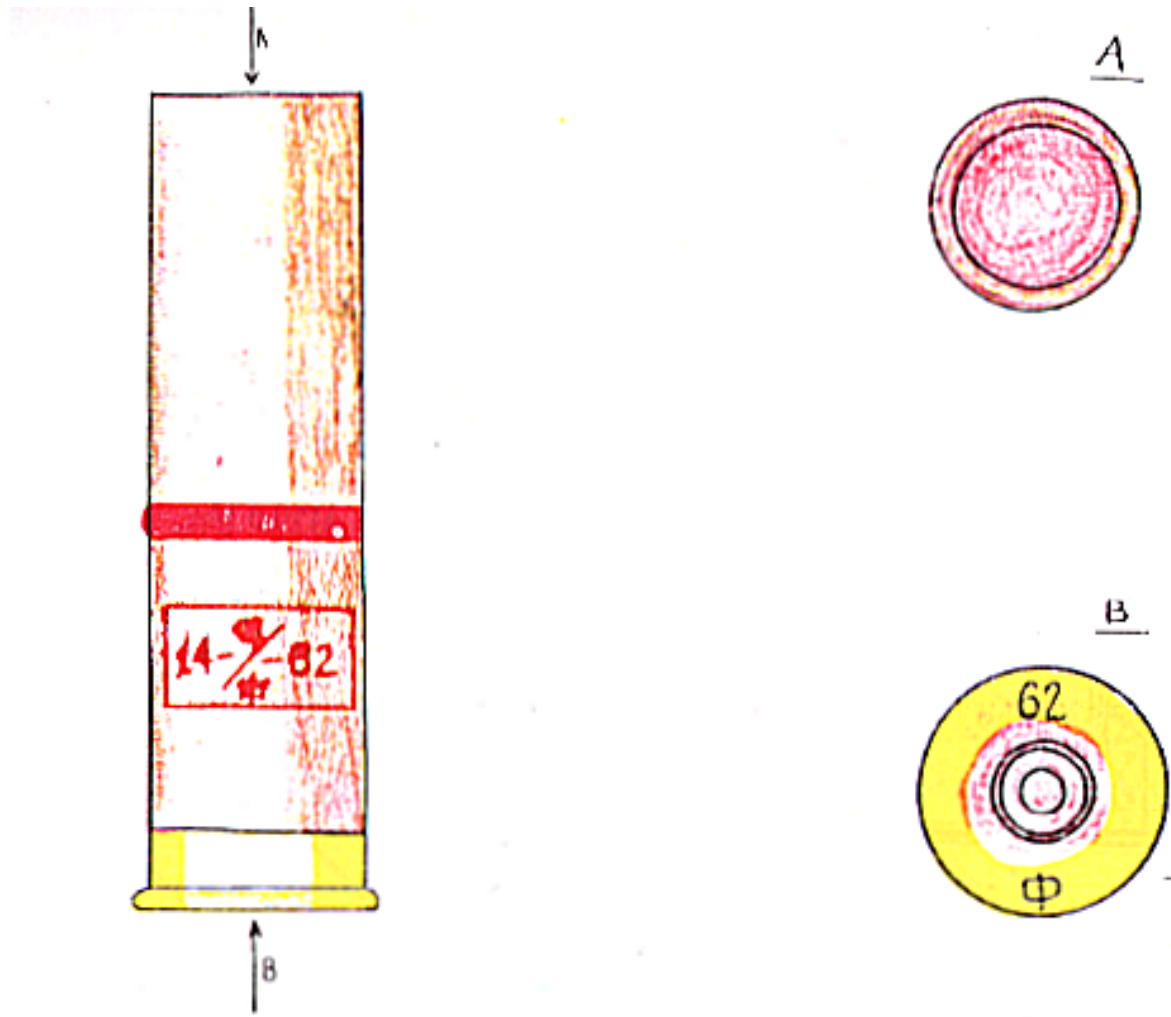
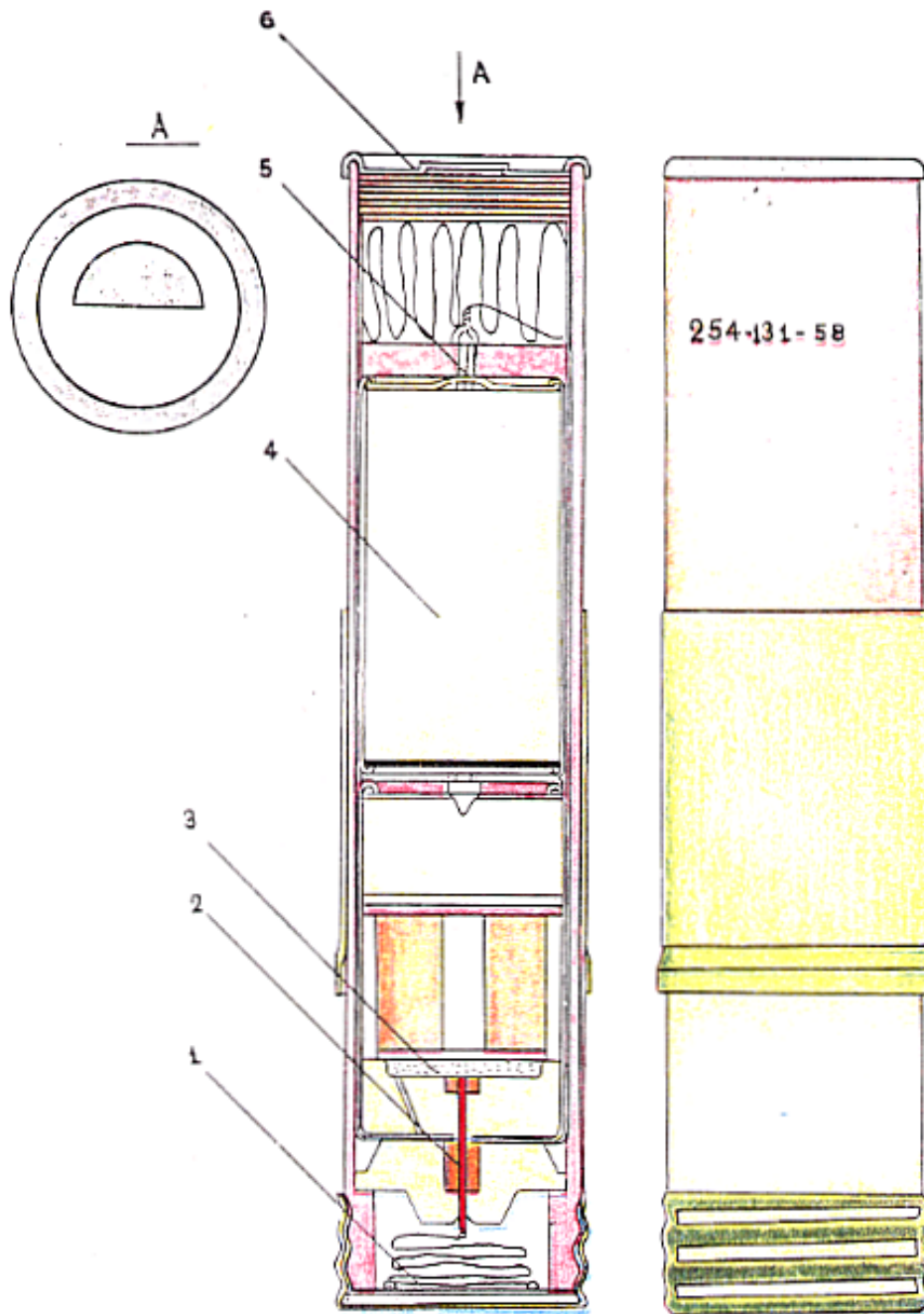

Figure 9-6 26 mm. daylight signalling round (red.)



- | | | | |
|----|-----------------------|----|------------------------|
| 1. | Pull-cord. | 4. | Illuminating material. |
| 2. | Friction igniter. | 5. | Parachute. |
| 3. | Gunpowder with smoke. | 6. | Cap. |

Figure 9-7 40 mm. illuminating rocket.

PART X

DRAWINGS OF FUZES

Presumably pages 341 and 342 are blank.[IN ORIGINAL]

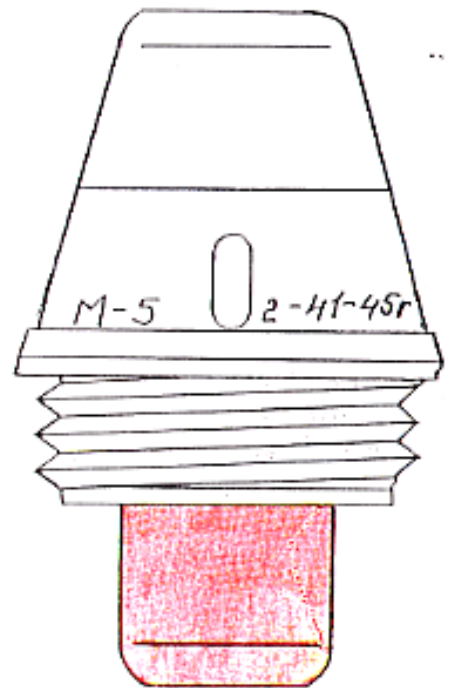
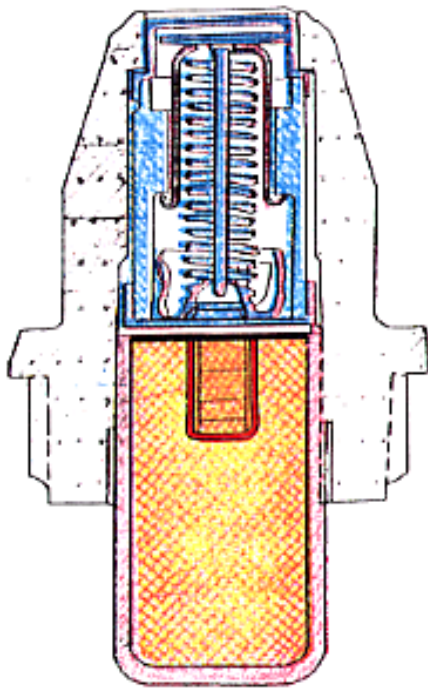

Figure 10-1 M-5 Fuze.

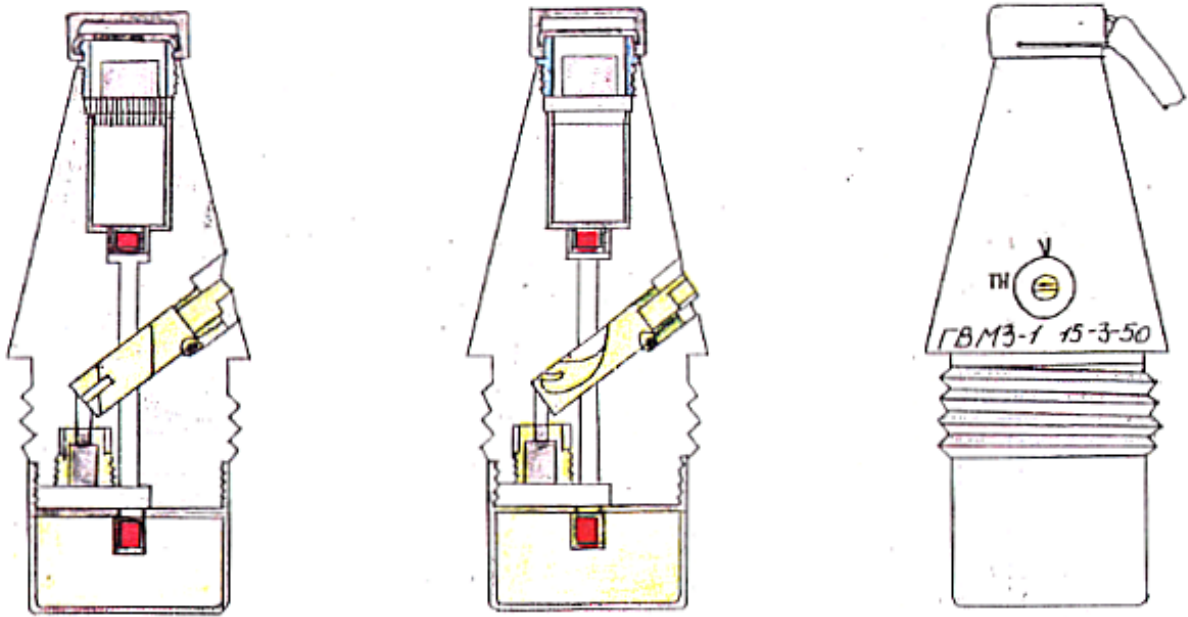

Figure 10-2 GVMZ-1 Fuze.

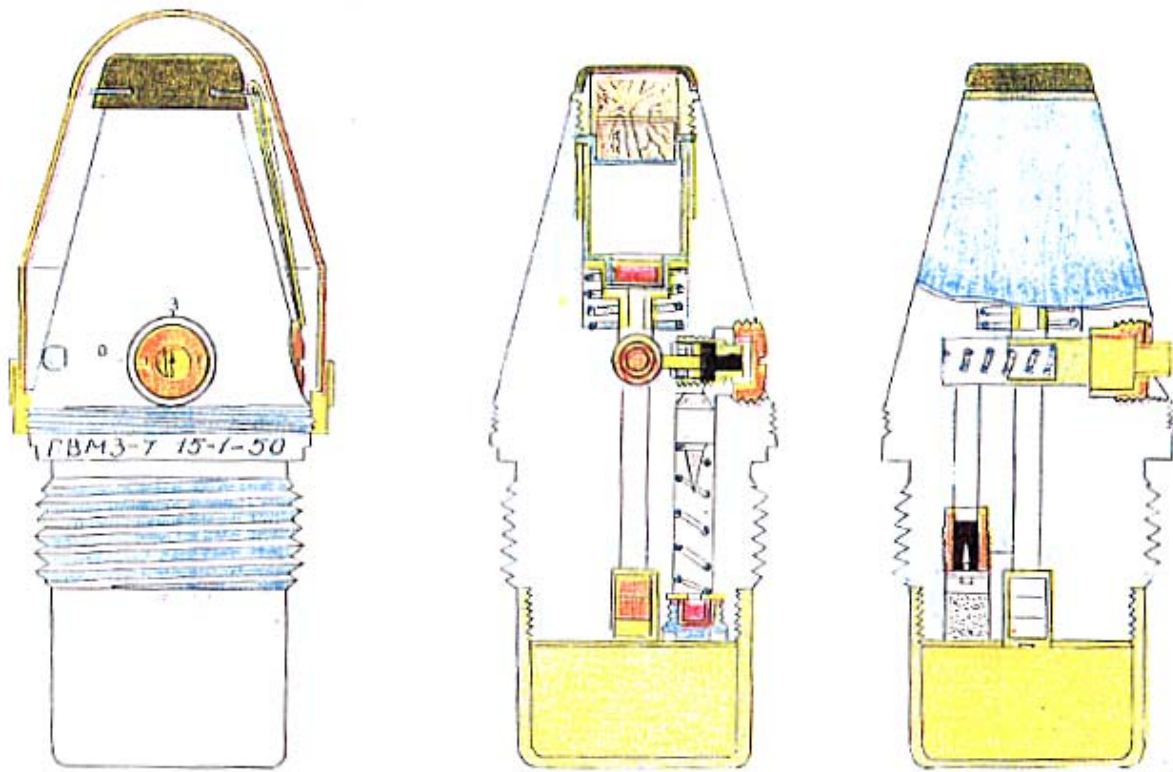

Figure 10-3 GVMZ-7 Fuze.

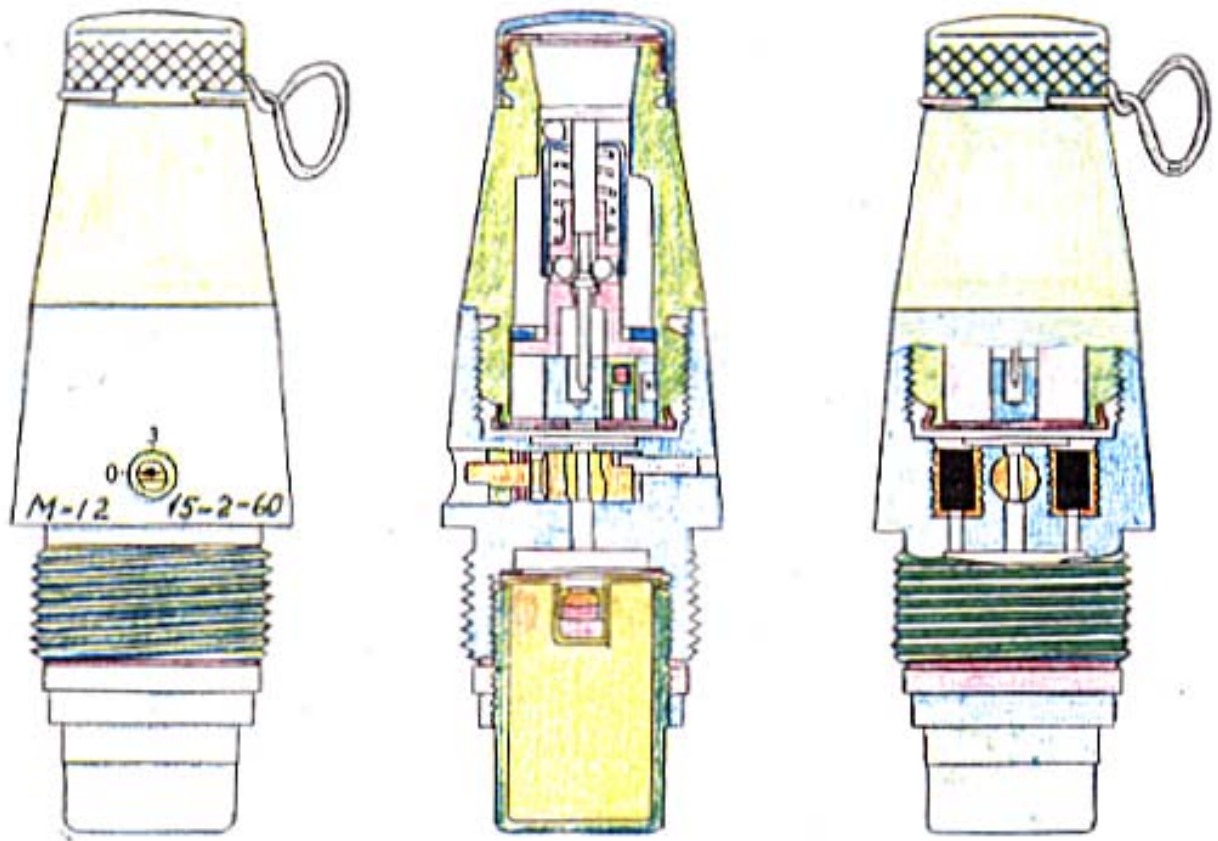

Figure 10-4 M-12 Fuze.

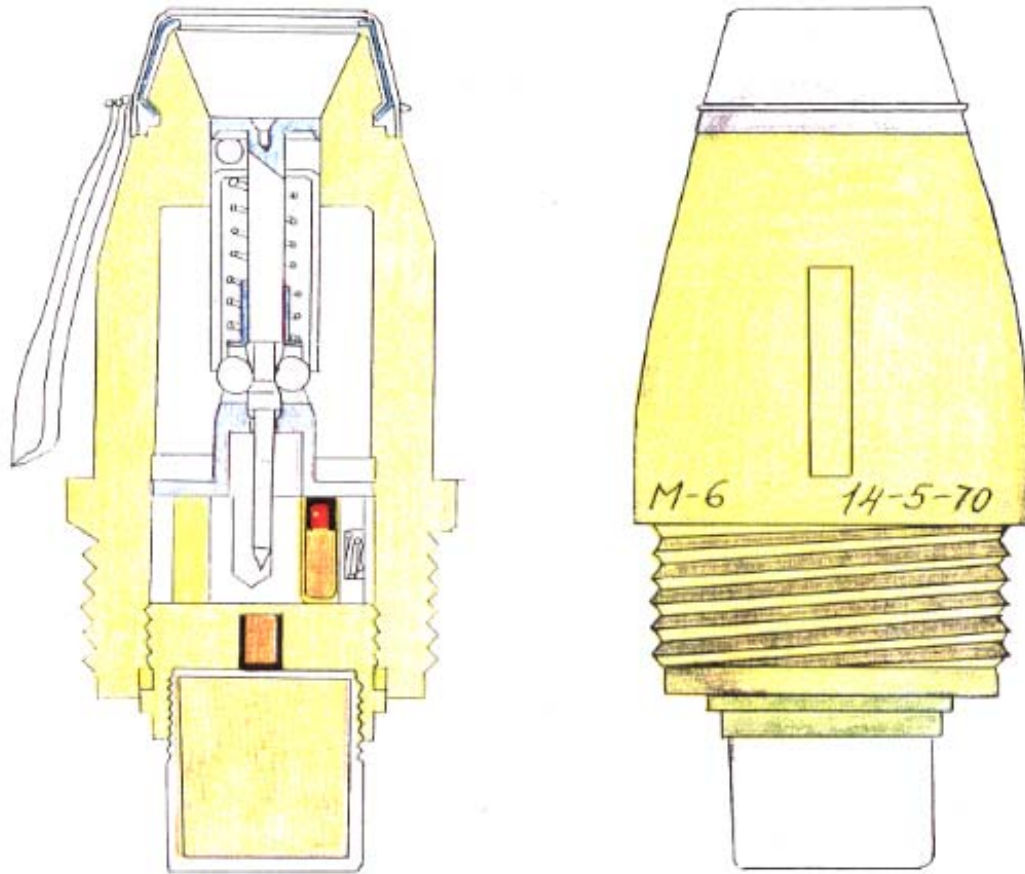

Figure 10-5 M-6 Fuze.

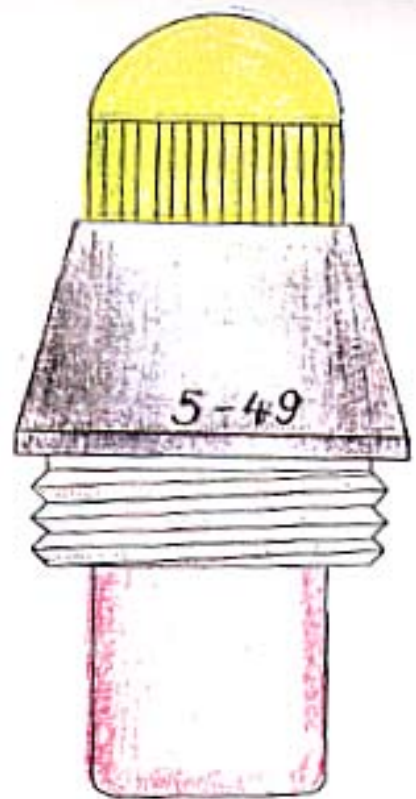
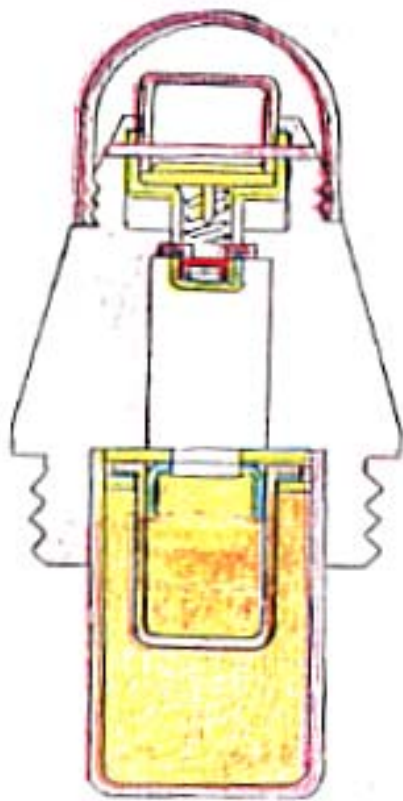

Figure 10-6 K-107 Fuze.

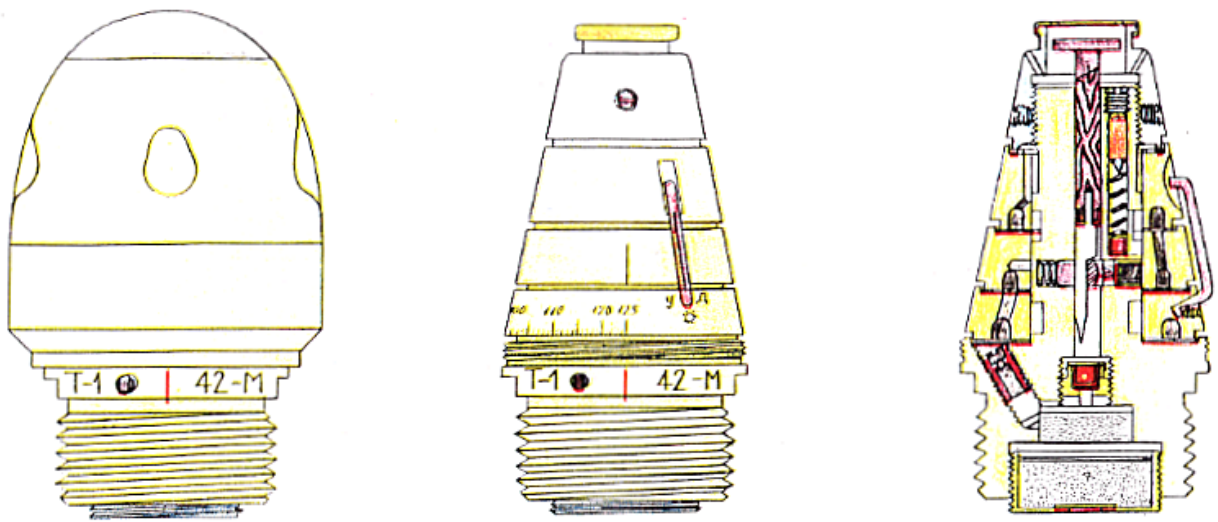

Figure 10-7 T-1 Fuze.

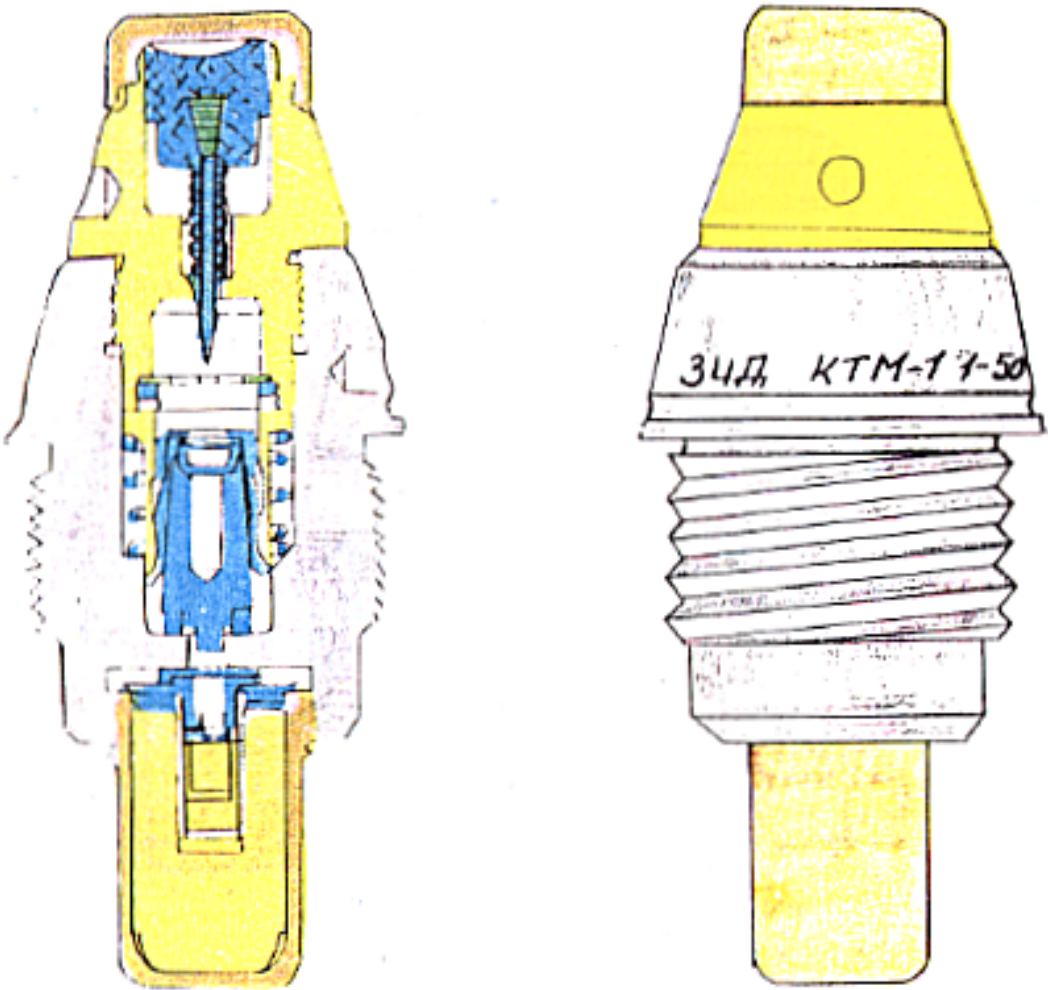

Figure 10-8 KTM-1 Fuze.

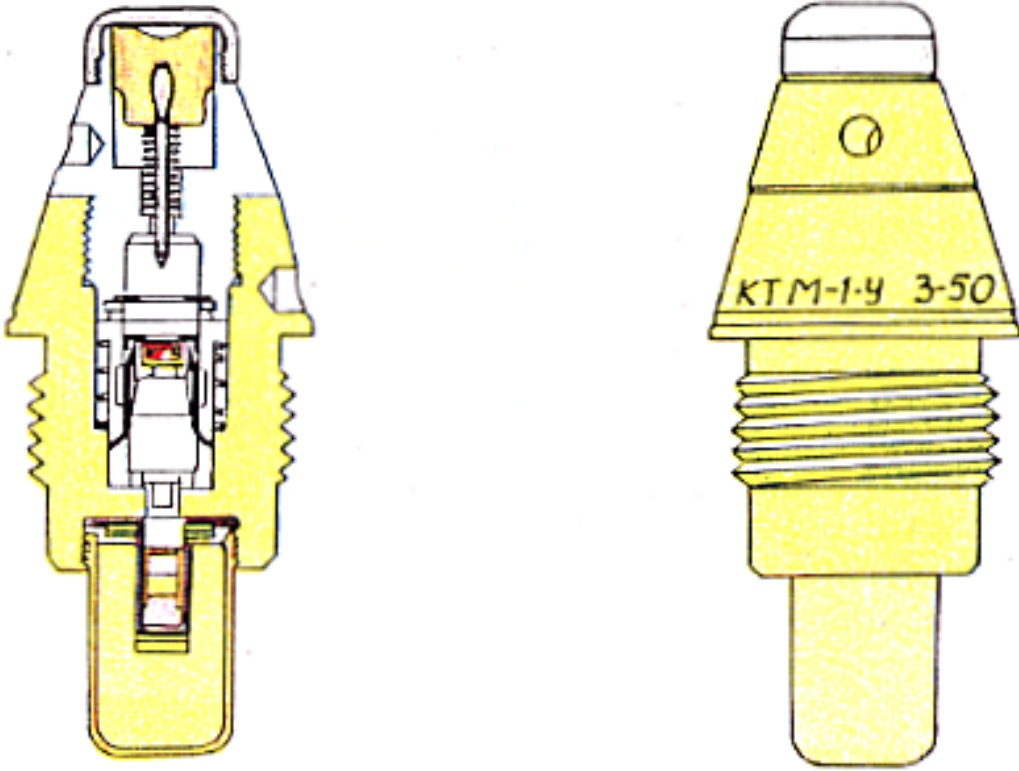

Figure 10-9 KTM-1U Fuze.

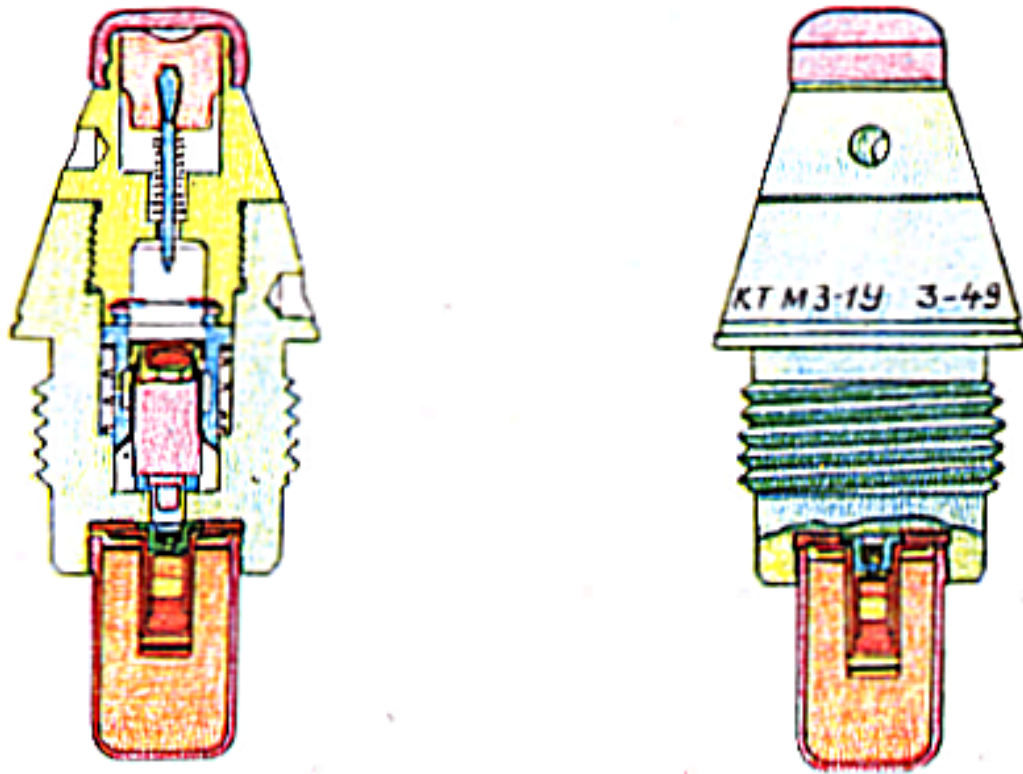

Figure 10-10 KTMZ-1U Fuze.

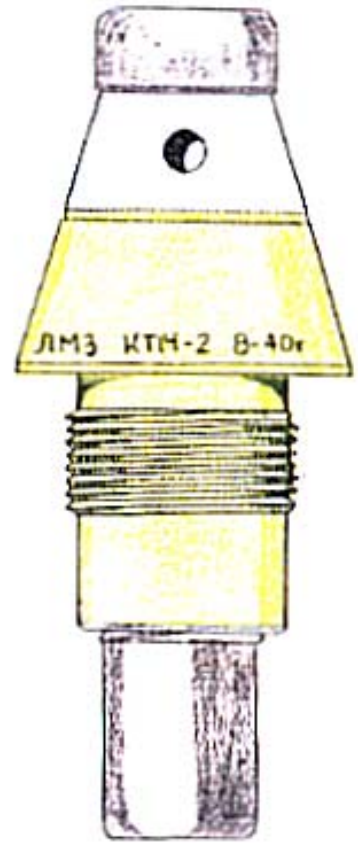
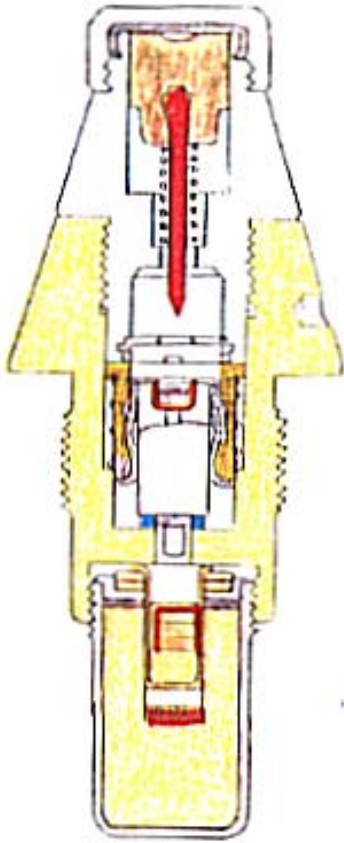

Figure 10-11 KTM-2 Fuze.

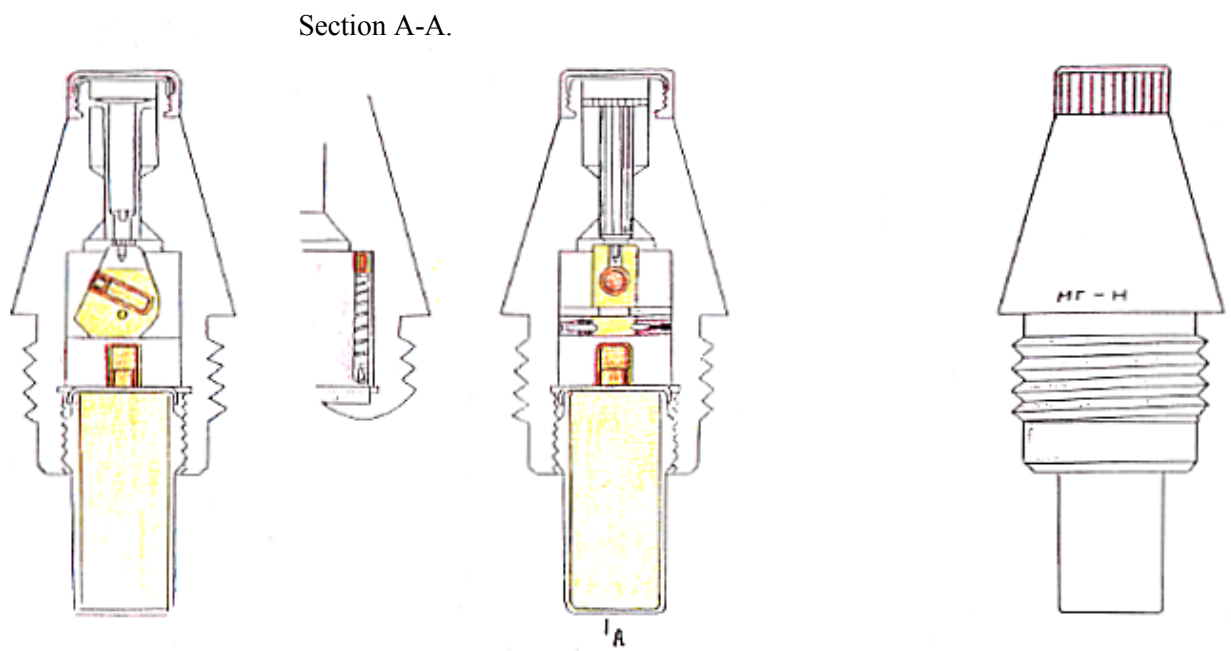

Figure 10-12 MGN Fuze.

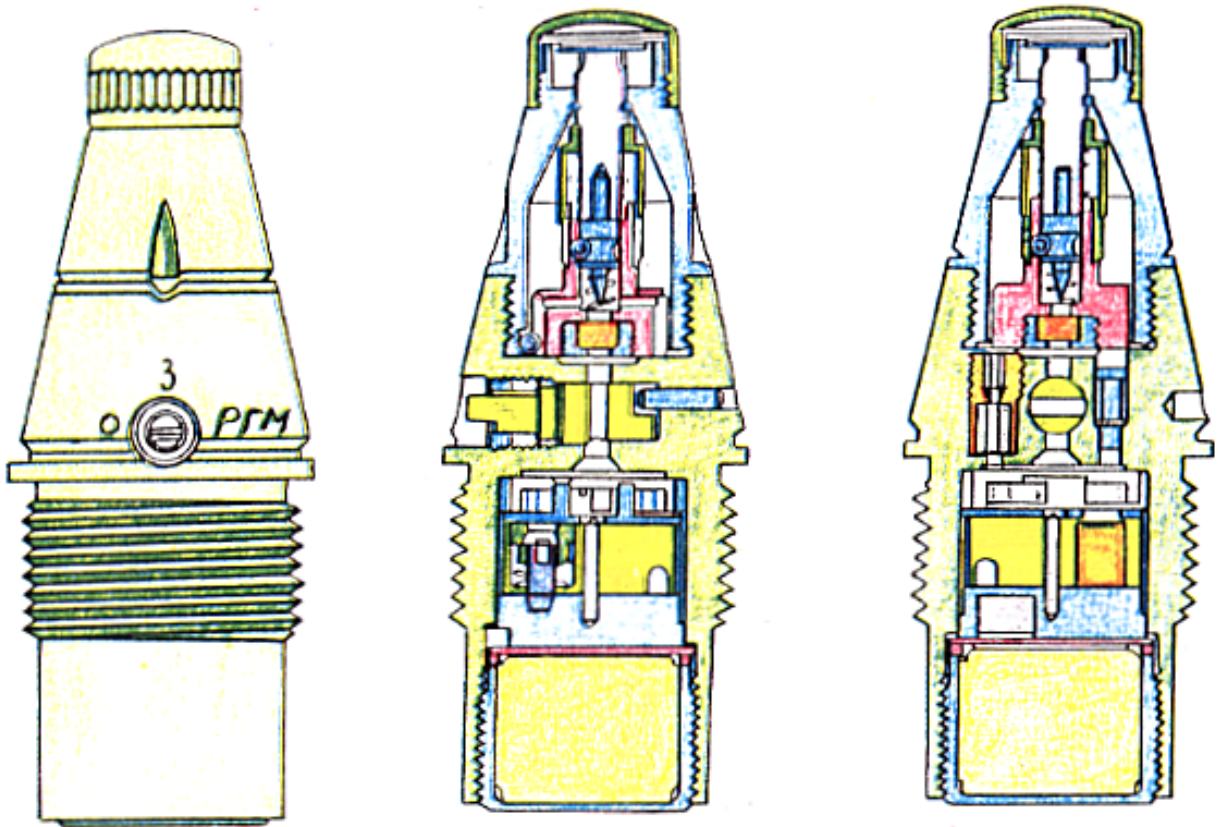

Figure 10-13 RGM Fuze.

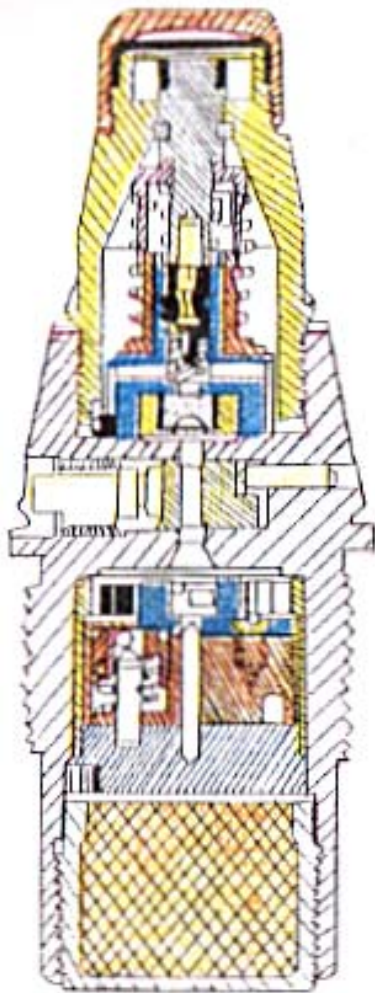

Figure 10-14 RGM-2 Fuze.

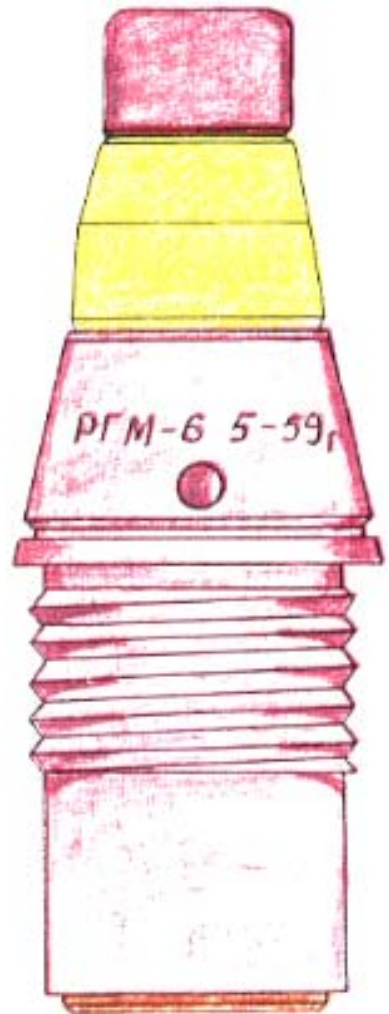
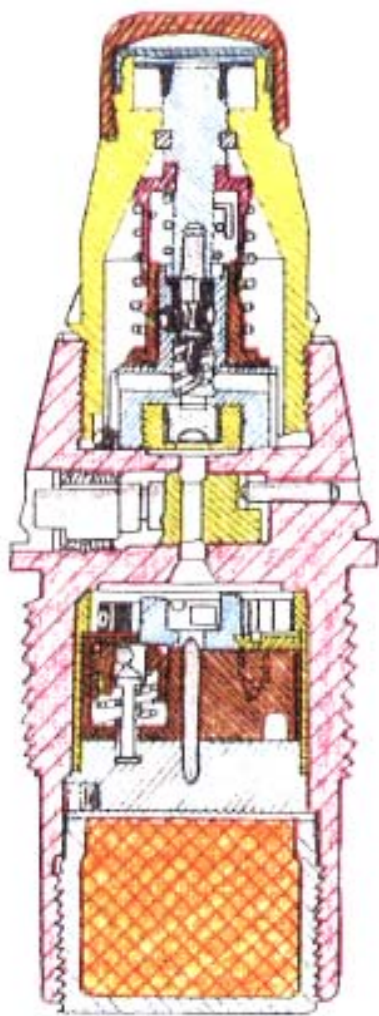

Figure 10-15 RGM-6 Fuze.

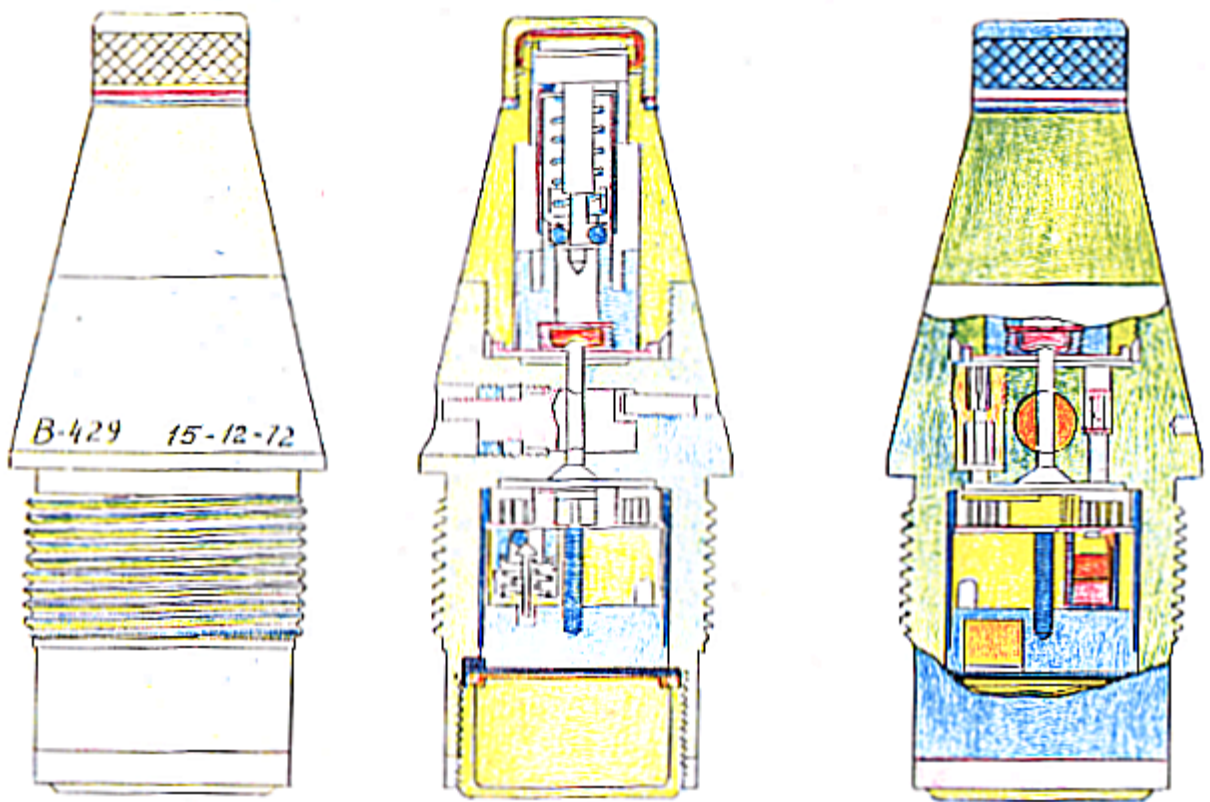

Figure 10-16 V-429 Fuze.

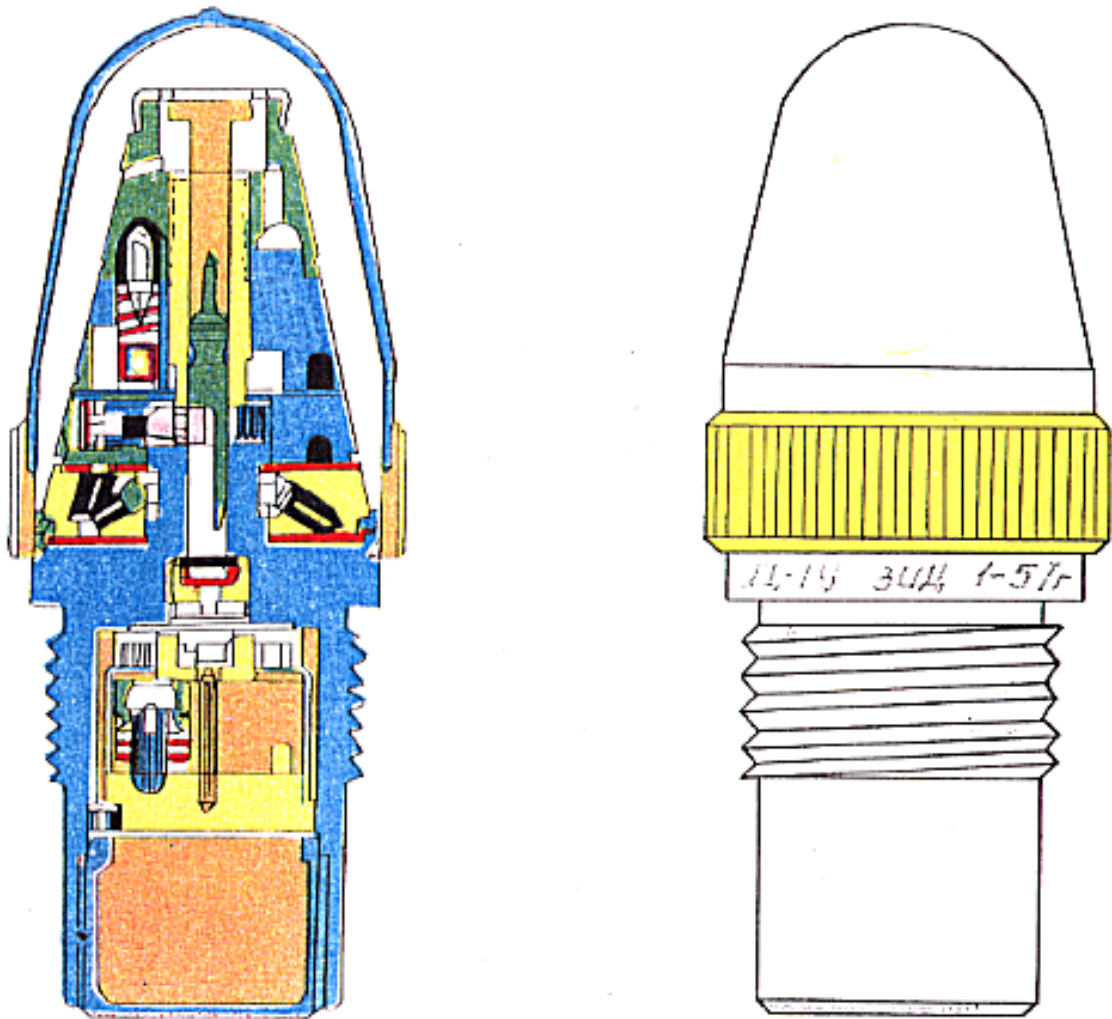

Figure 10-17 D-1U Fuze.

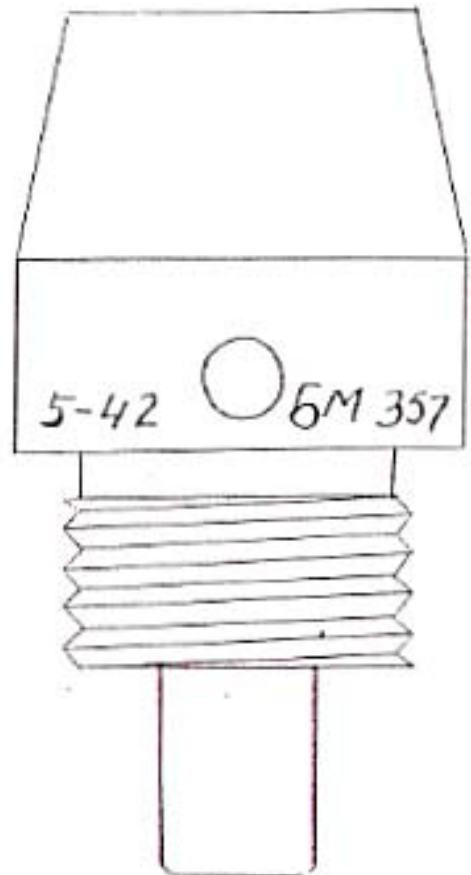
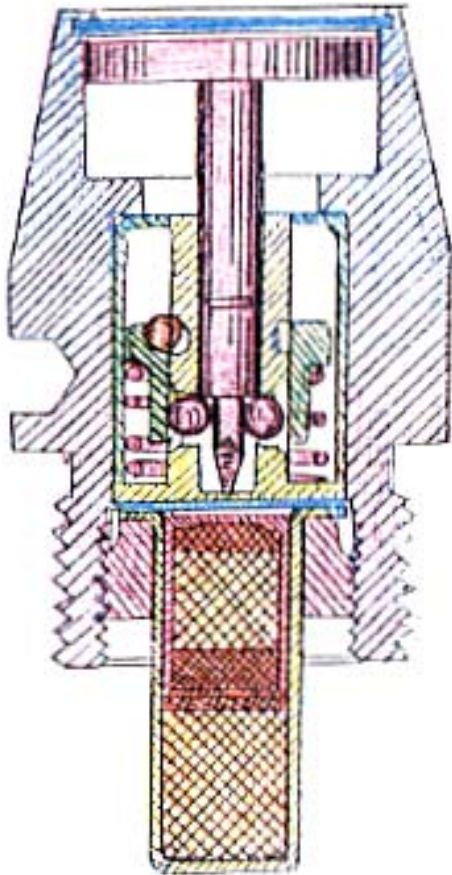

Figure 10-18 BM Fuze.

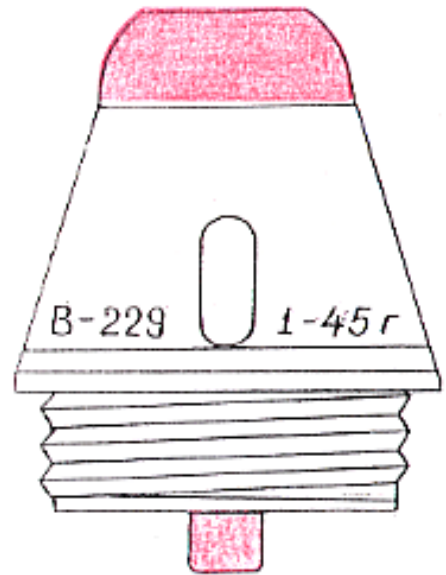
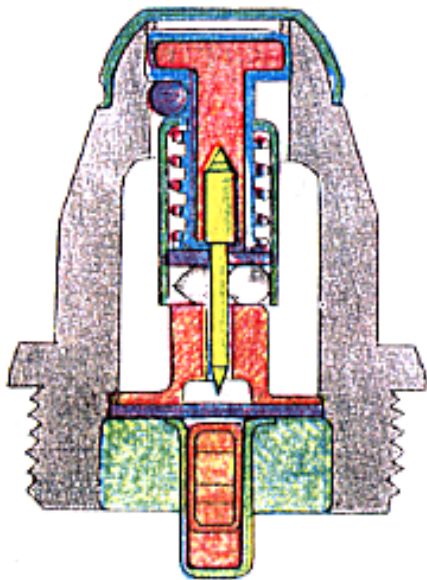

Figure 10-19 V-229 Fuze.

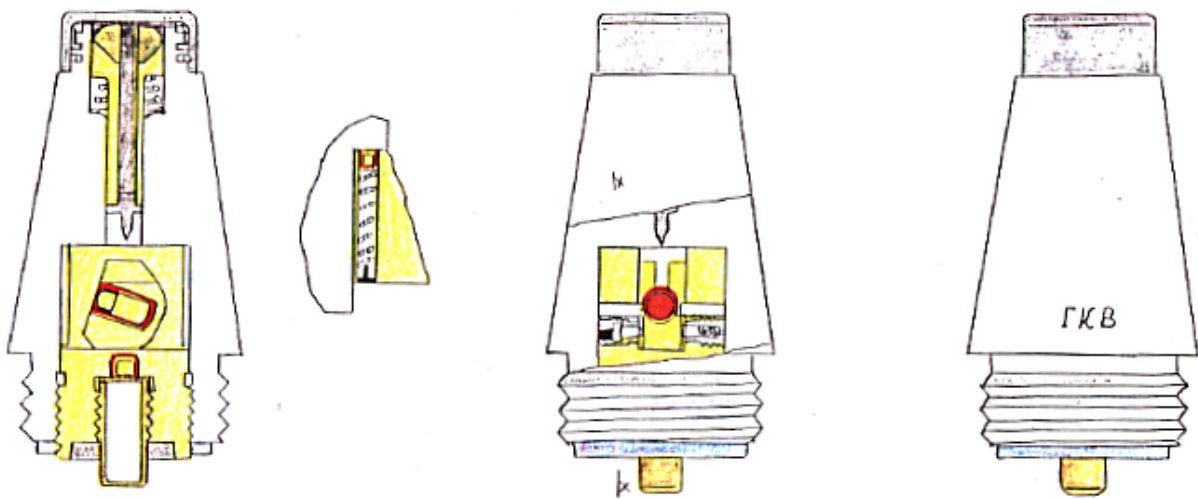

Figure 10-20 GKV Fuze.

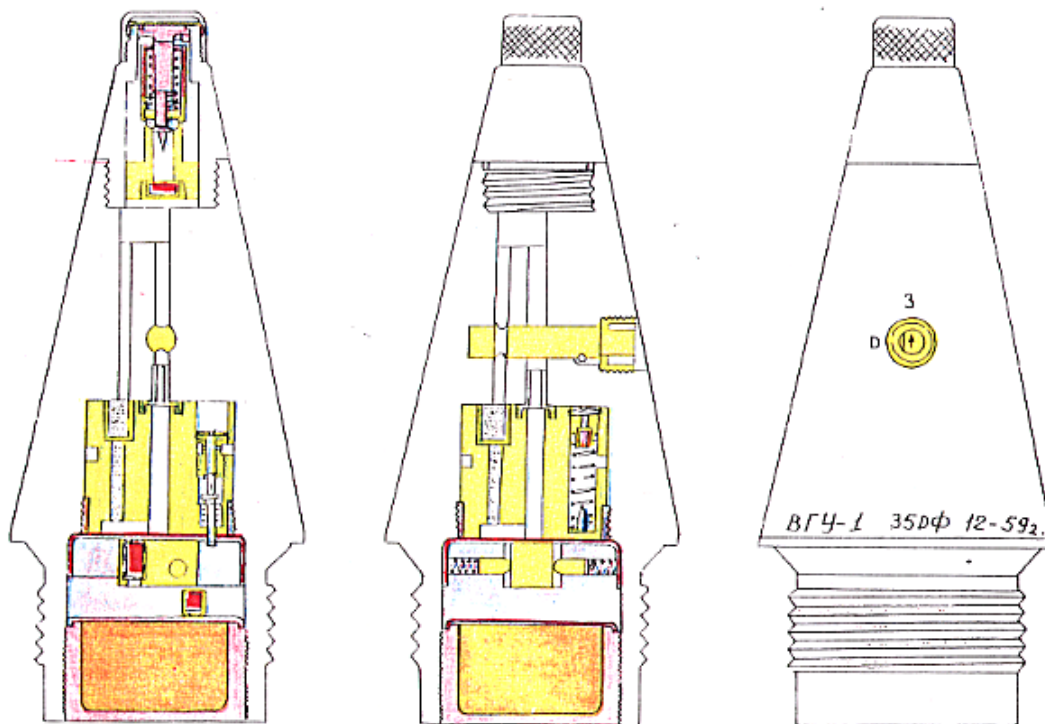

Figure 10-21 VGU-1 Fuze.

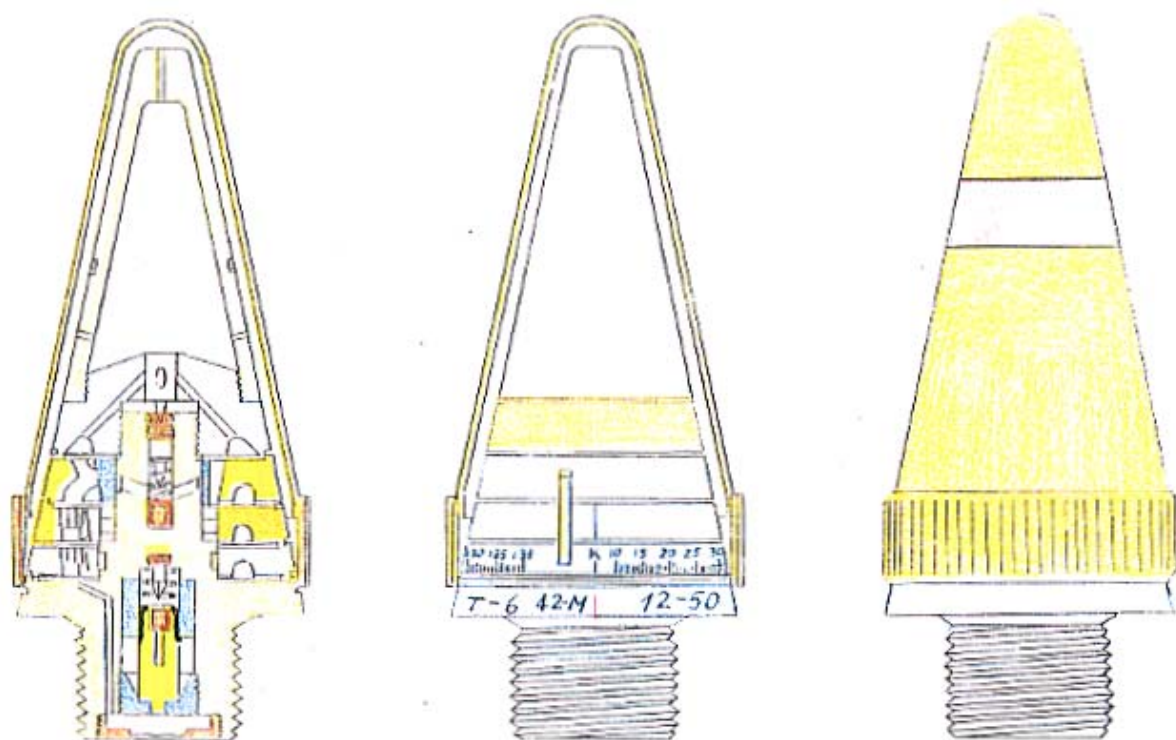

Figure 10-22 T-6 Fuze.

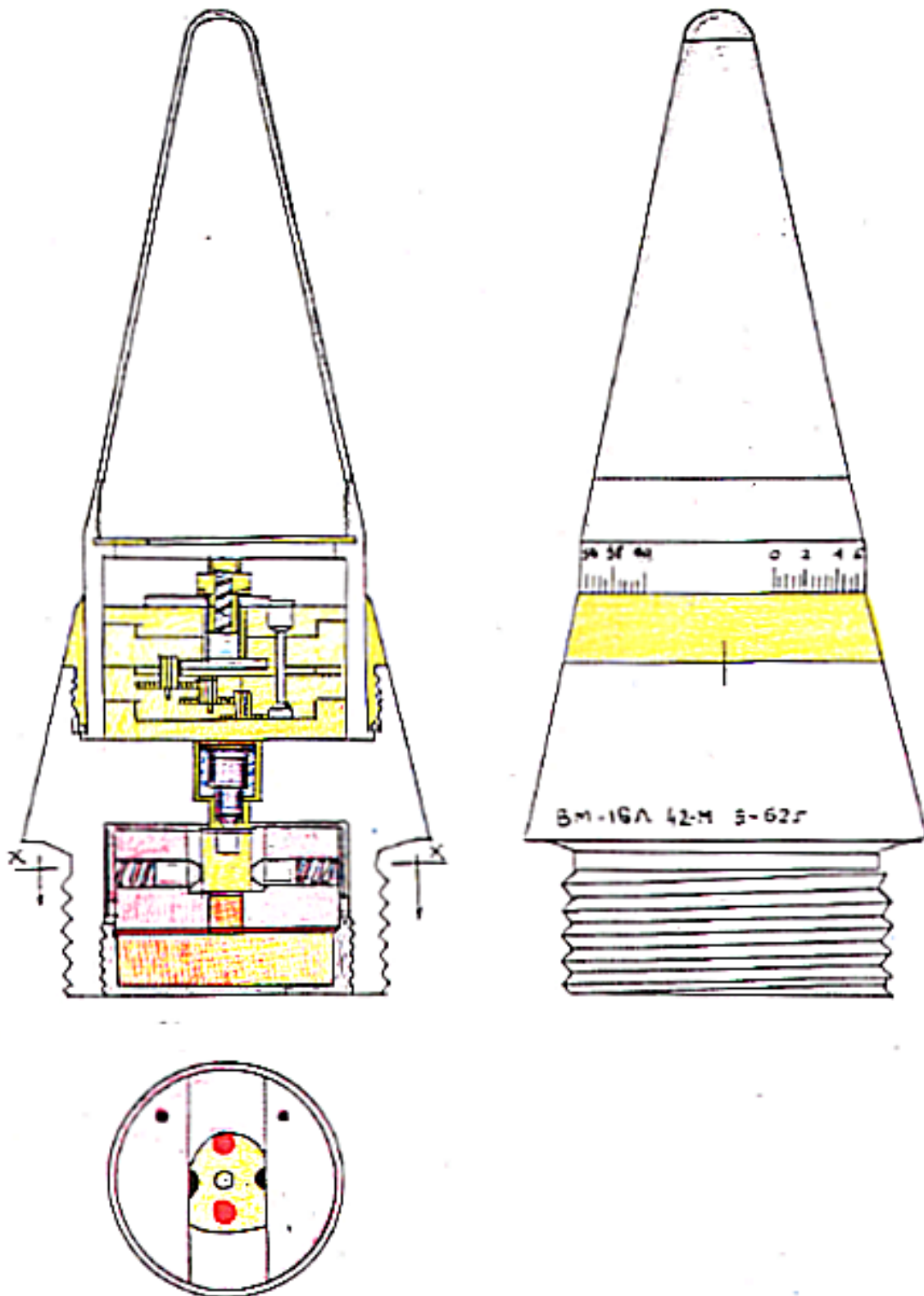

Figure 10-24 VM-16 Fuze.

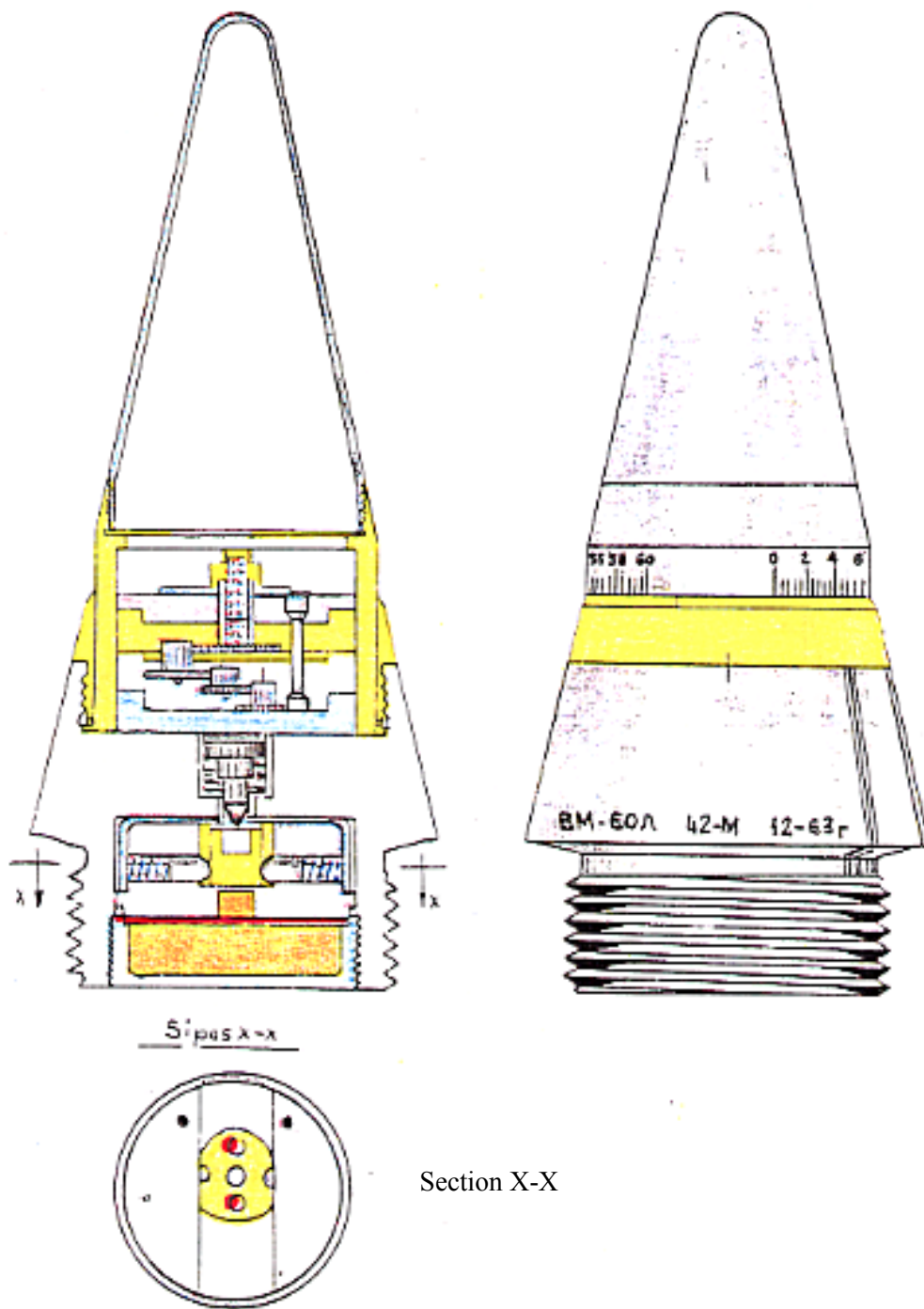

Figure 10-25 VM-60 Fuze.

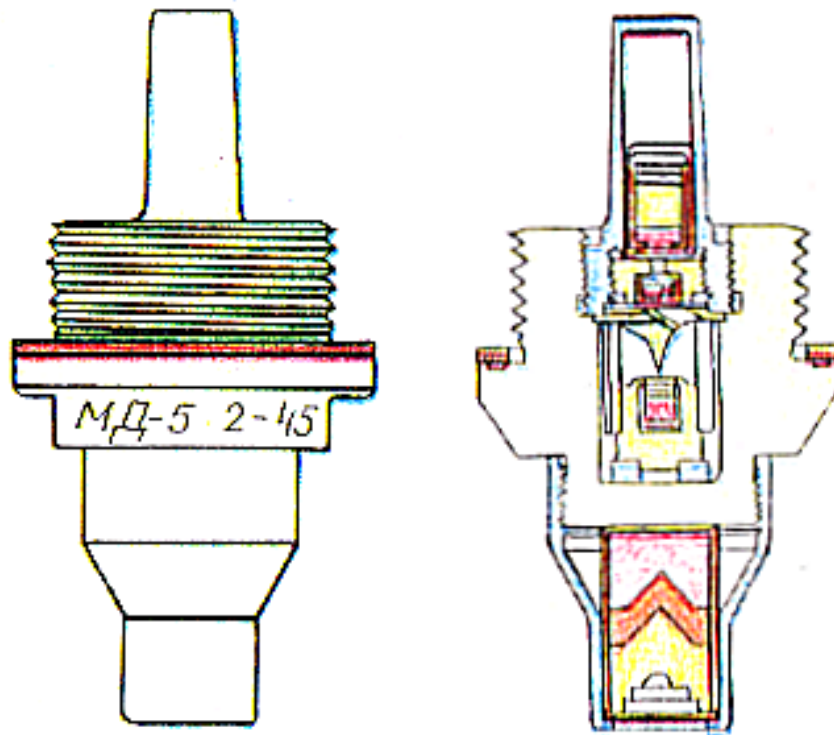

Figure 10-26 MD-5 Fuze.

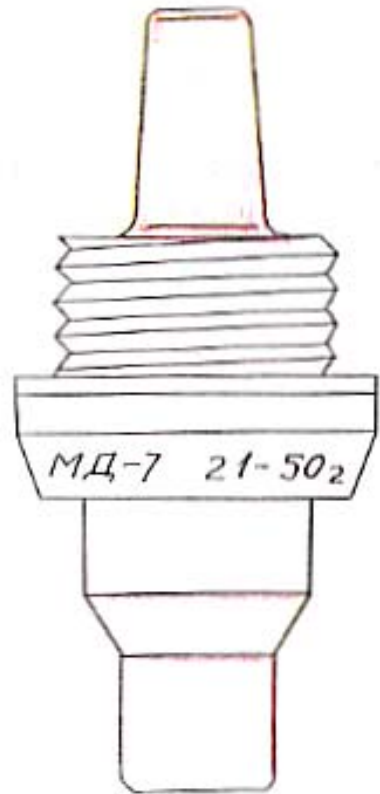
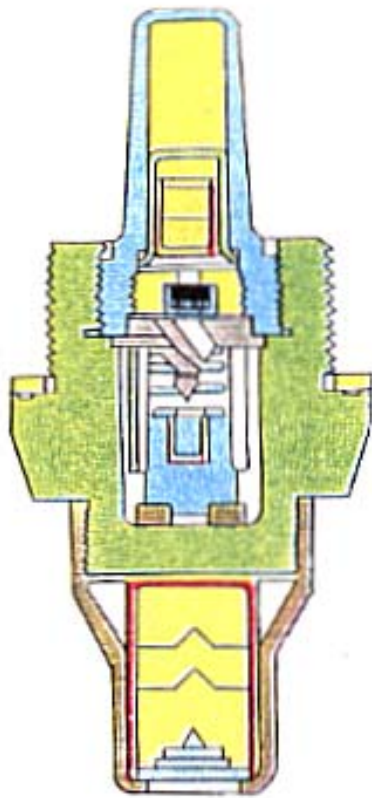

Figure 10-27 MD-7 Fuze.

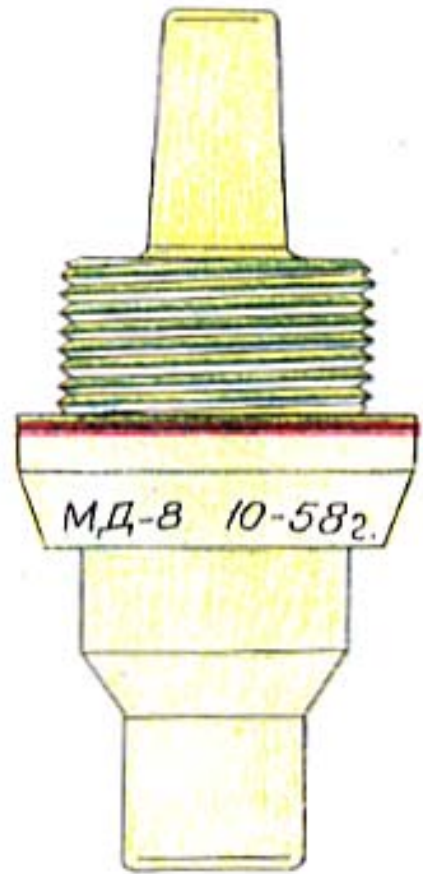
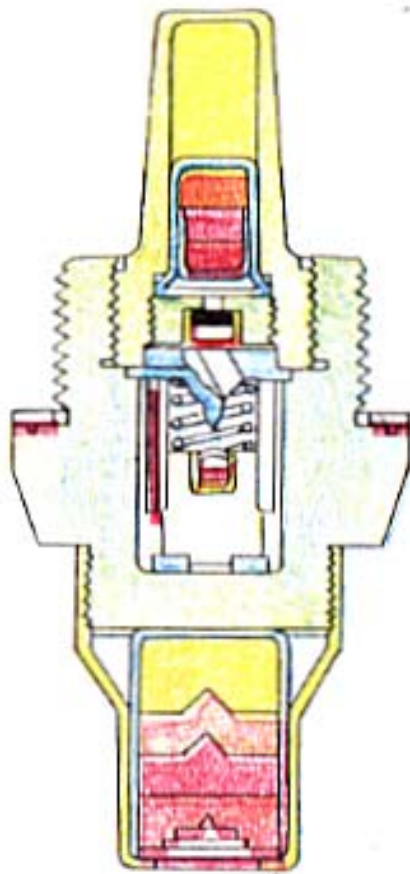
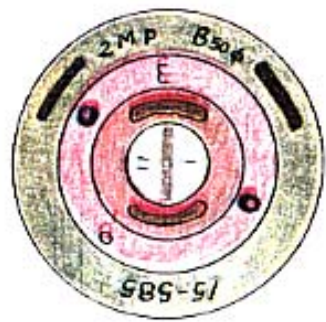

Figure 10-28 MD-8 Fuze.



View A

Figure 10-29 2-MR Fuze.

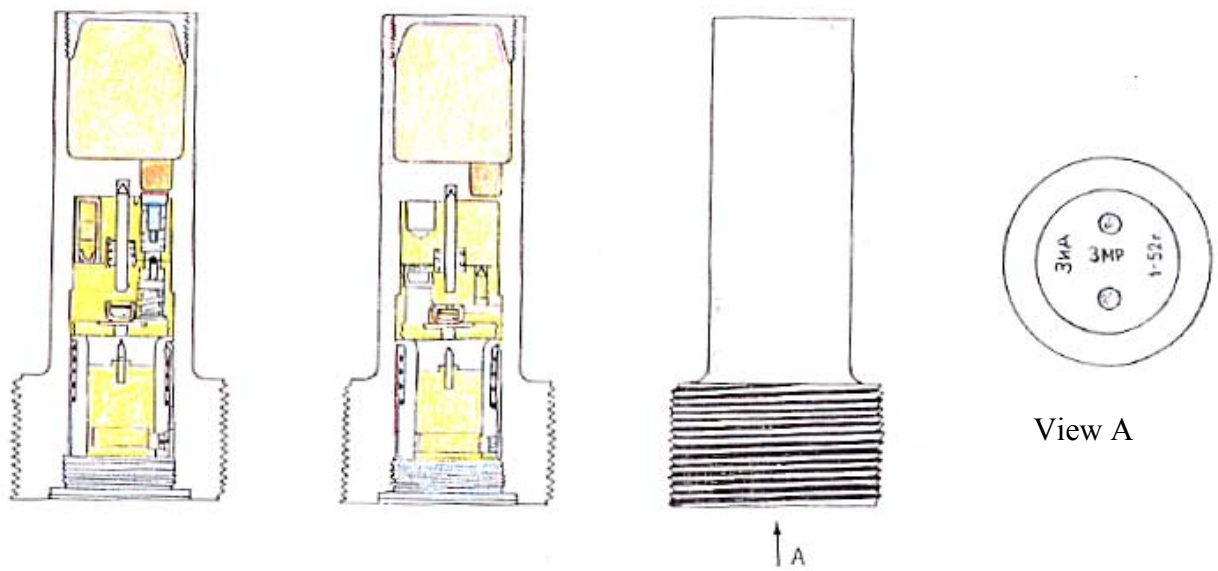

Figure 10-30 ZMR Fuze.

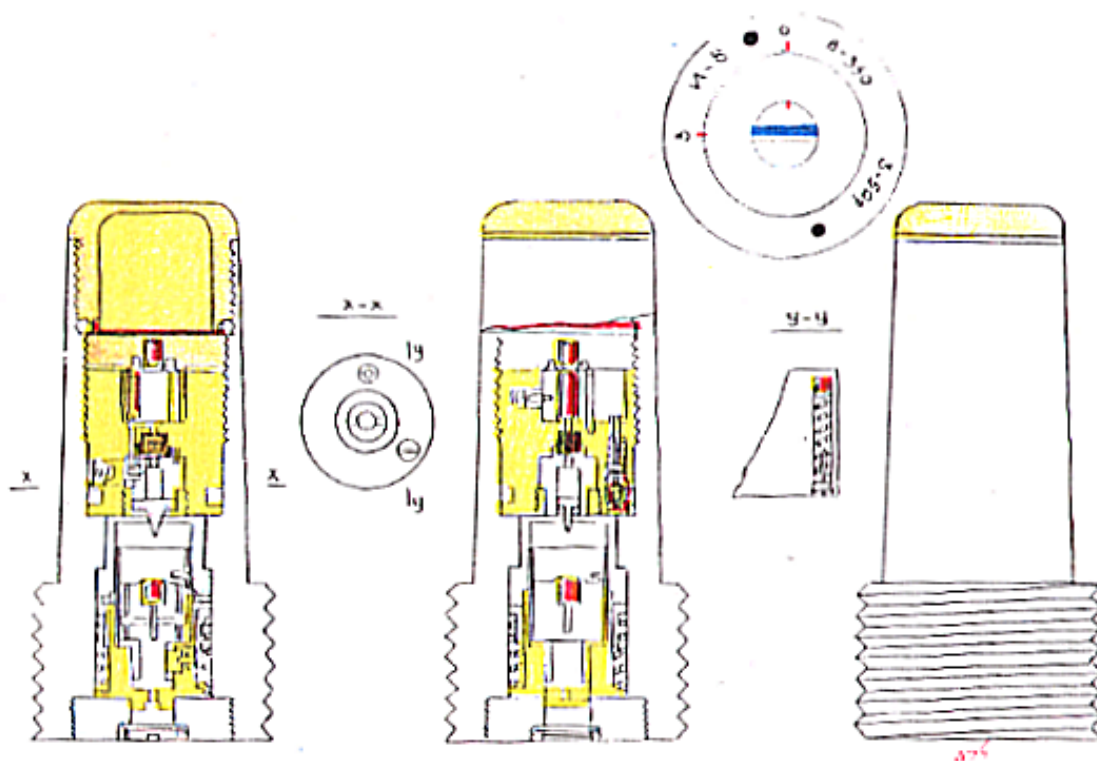

Figure 10-31 V-350 Fuze.

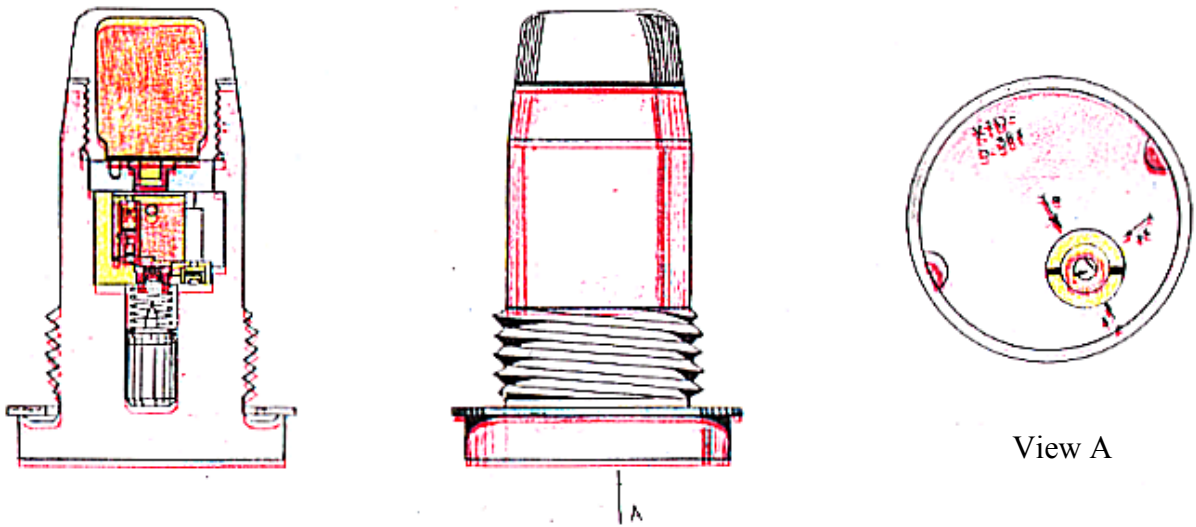

Figure 10-32 KTD Fuze.

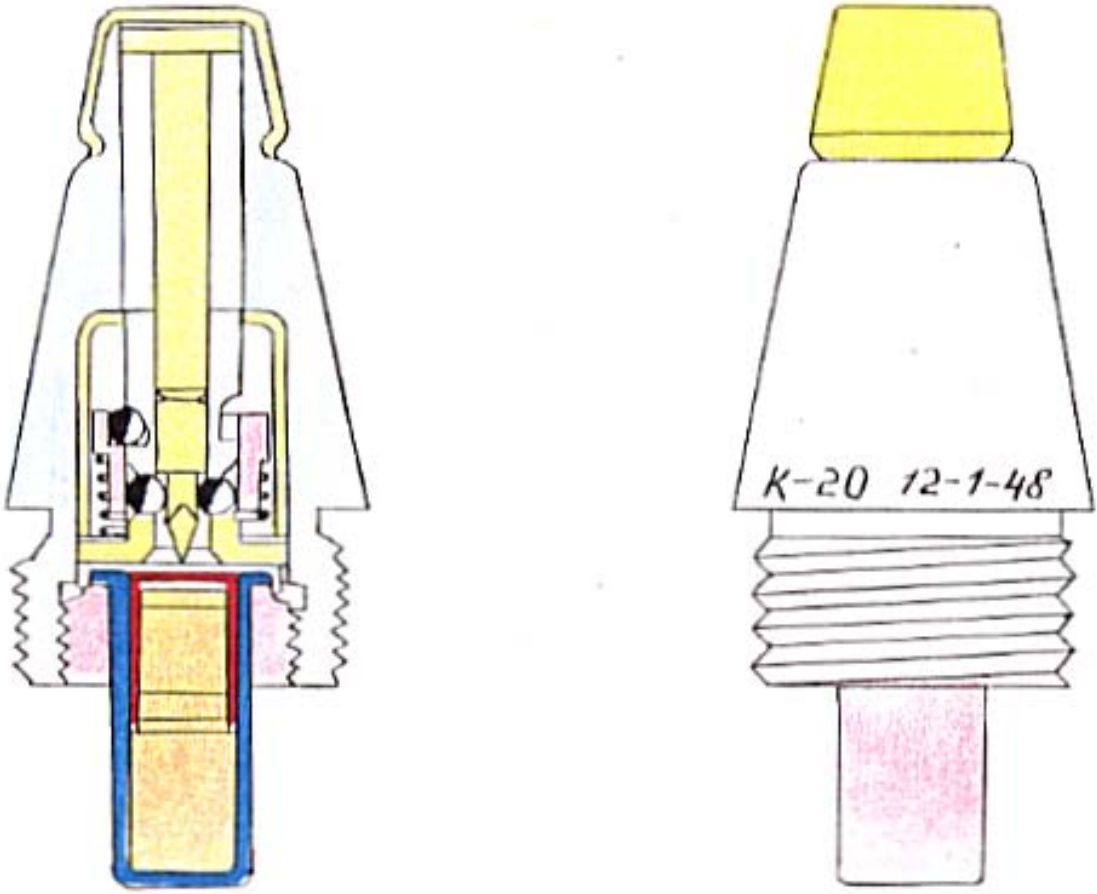

Figure 10-33 K-20 Fuze.

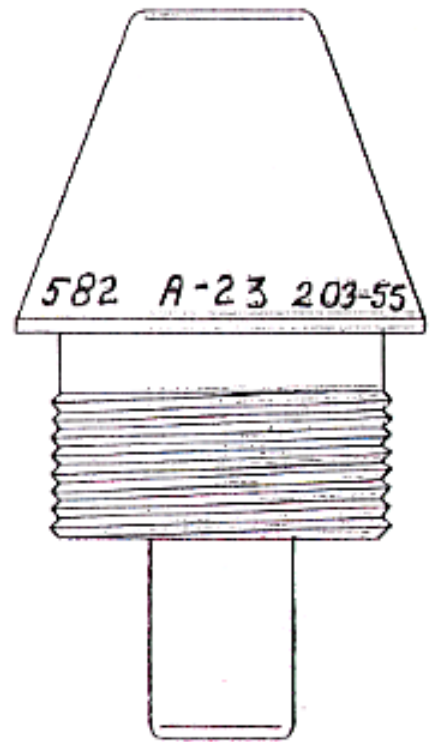
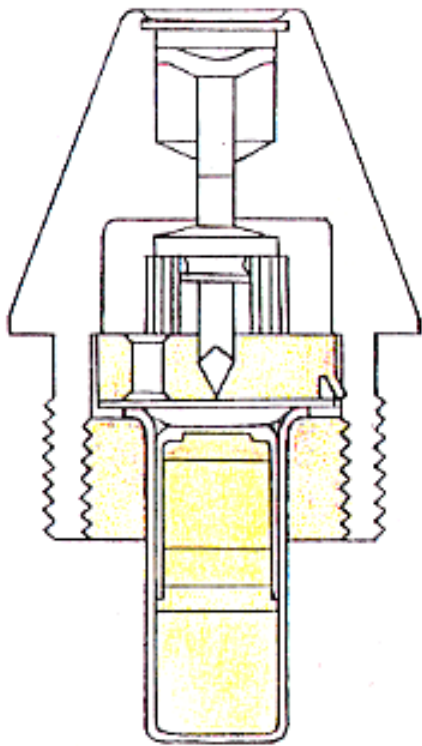

Figure 10-34 A-23 Fuze.

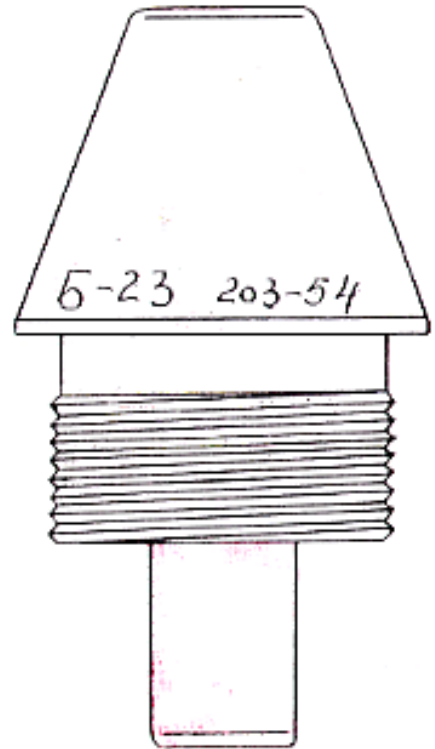
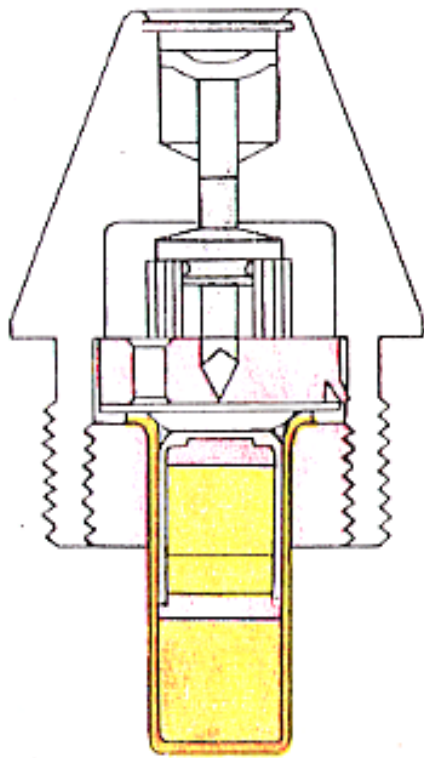

Figure 10-35 B-23 Fuze.

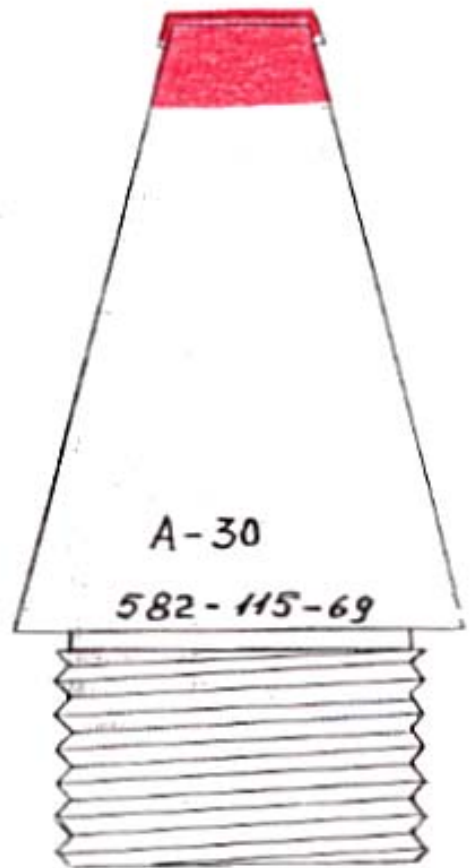
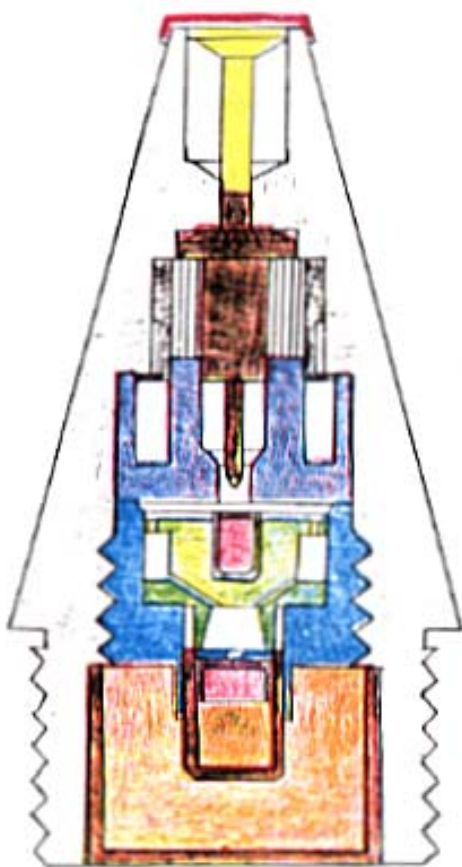

Figure 10-36 A-30 Fuze.

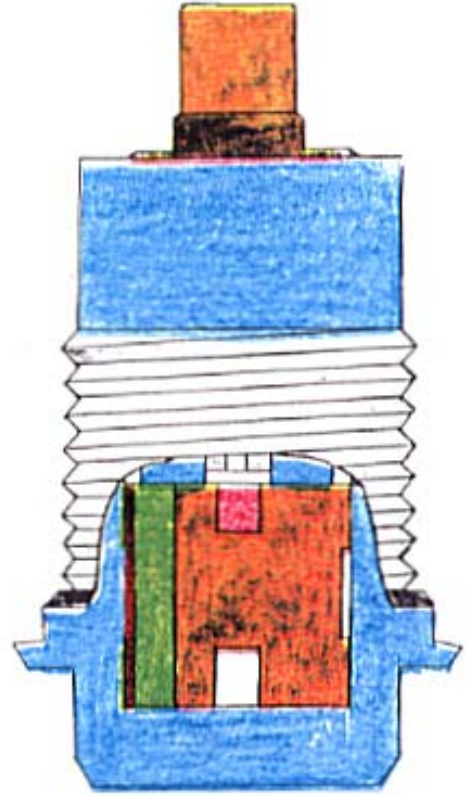
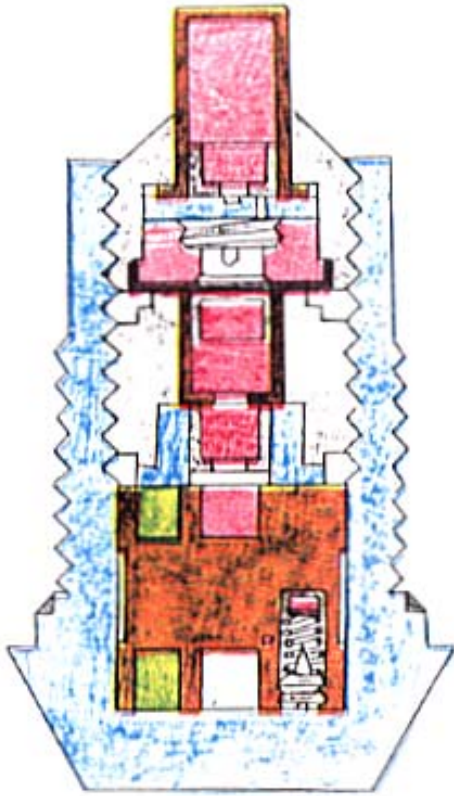

Figure 10-37 30-1 Fuze.

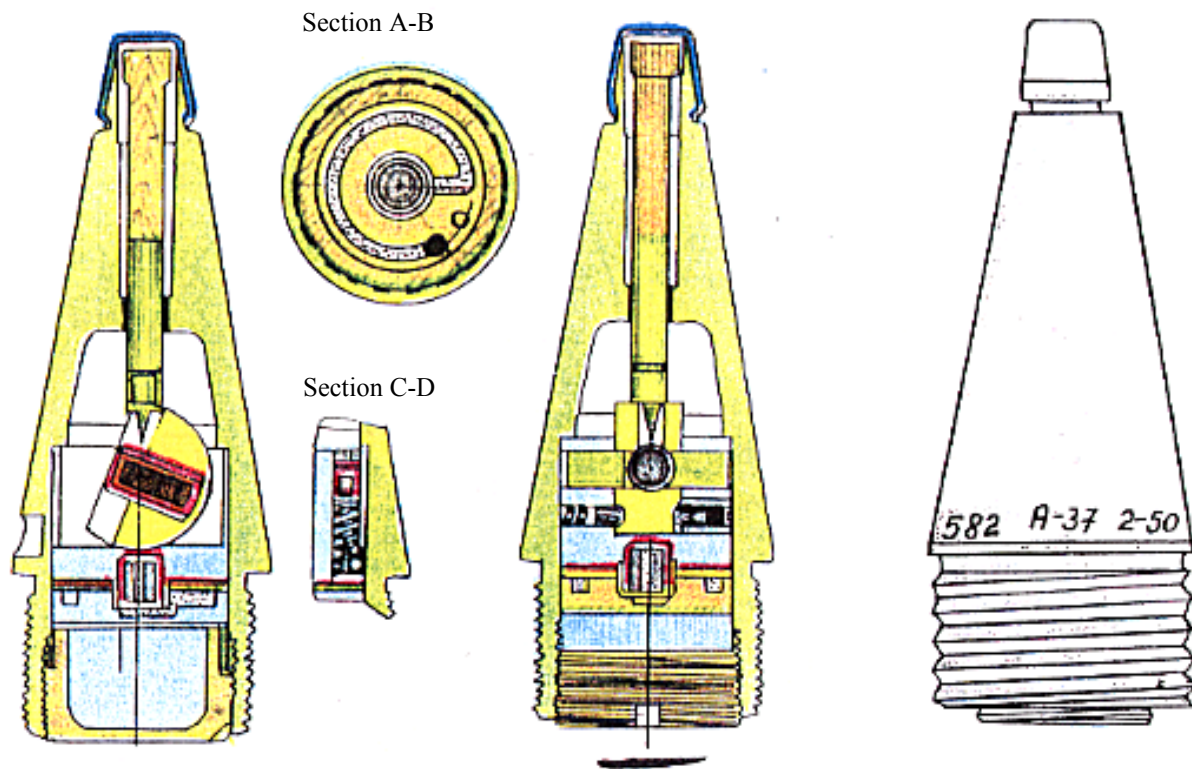

Figure 10-38 A-37 Fuze.

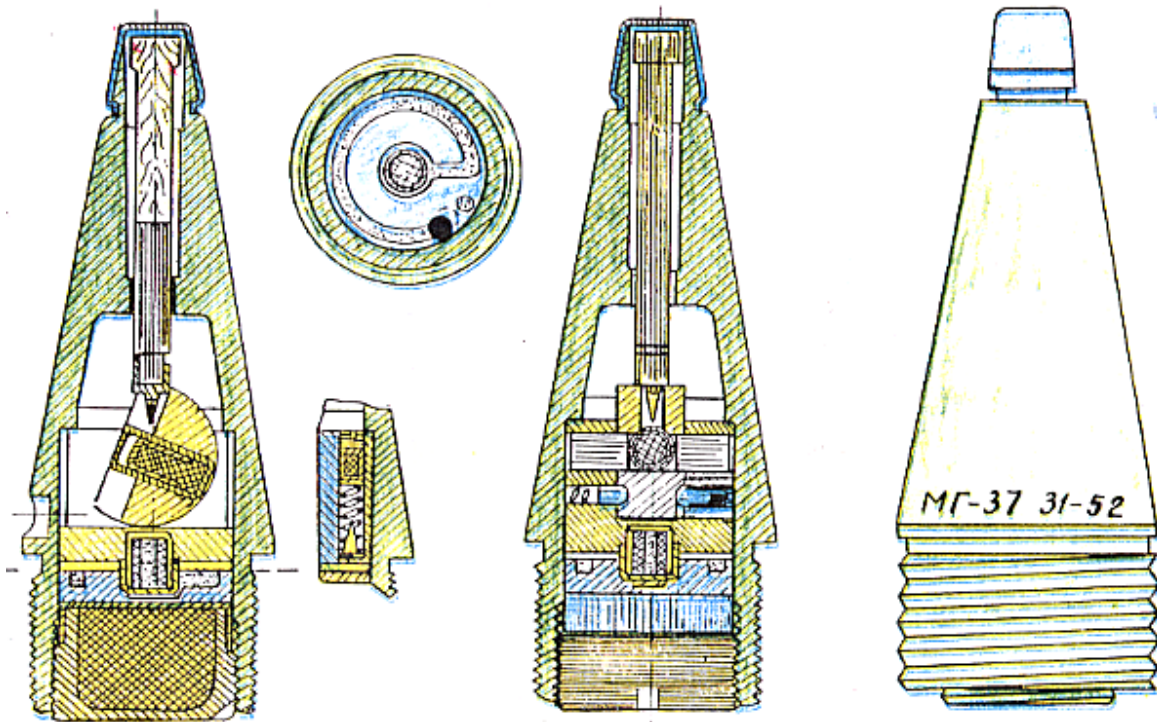

Figure 10-39 MG-37 Fuze.

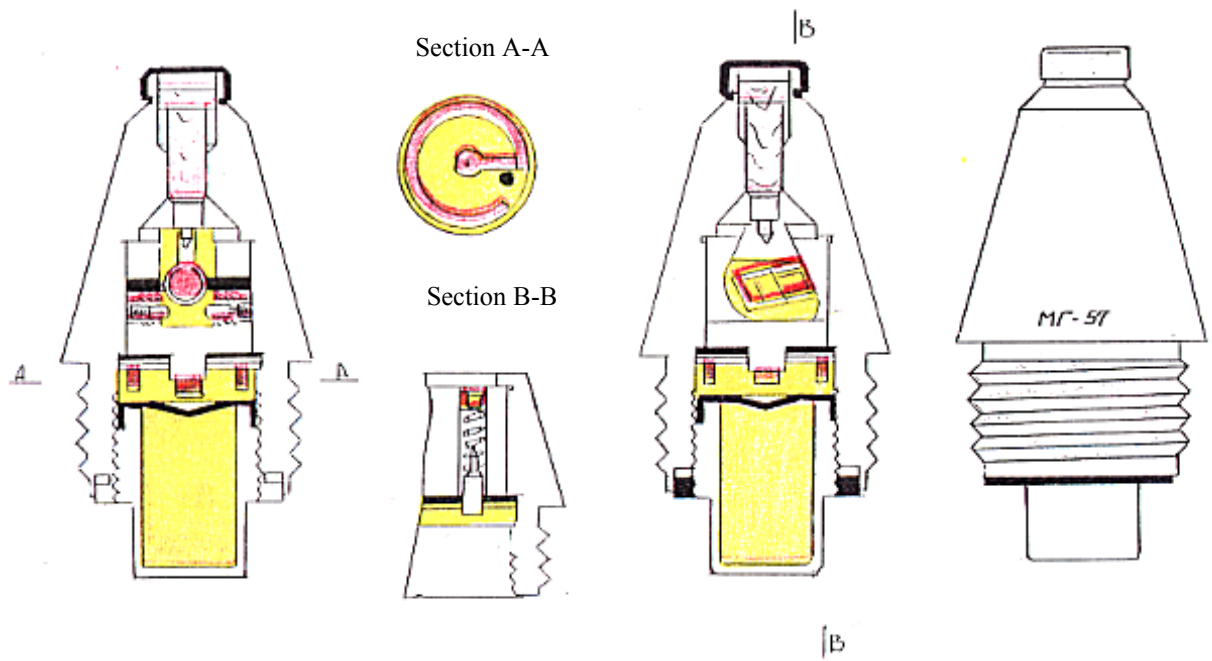

Figure 10-40 MG-57 Fuze.

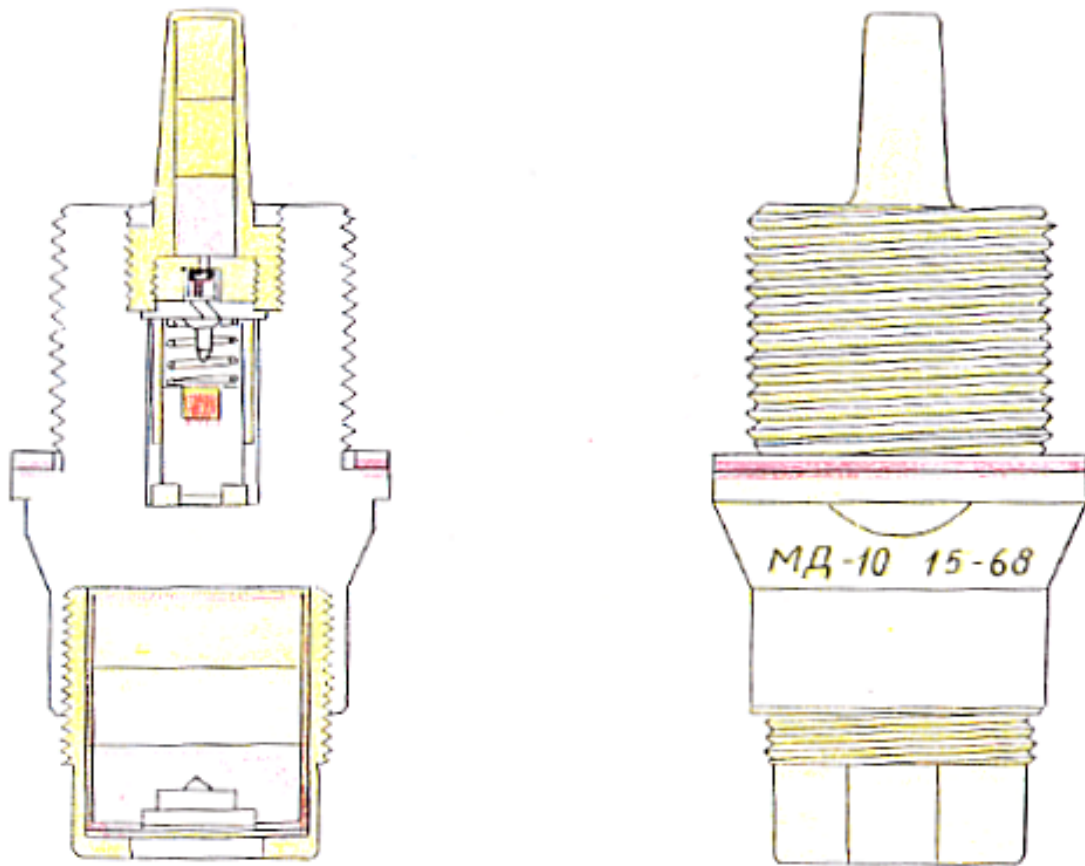

Figure 10-41 MD-10 Fuze.

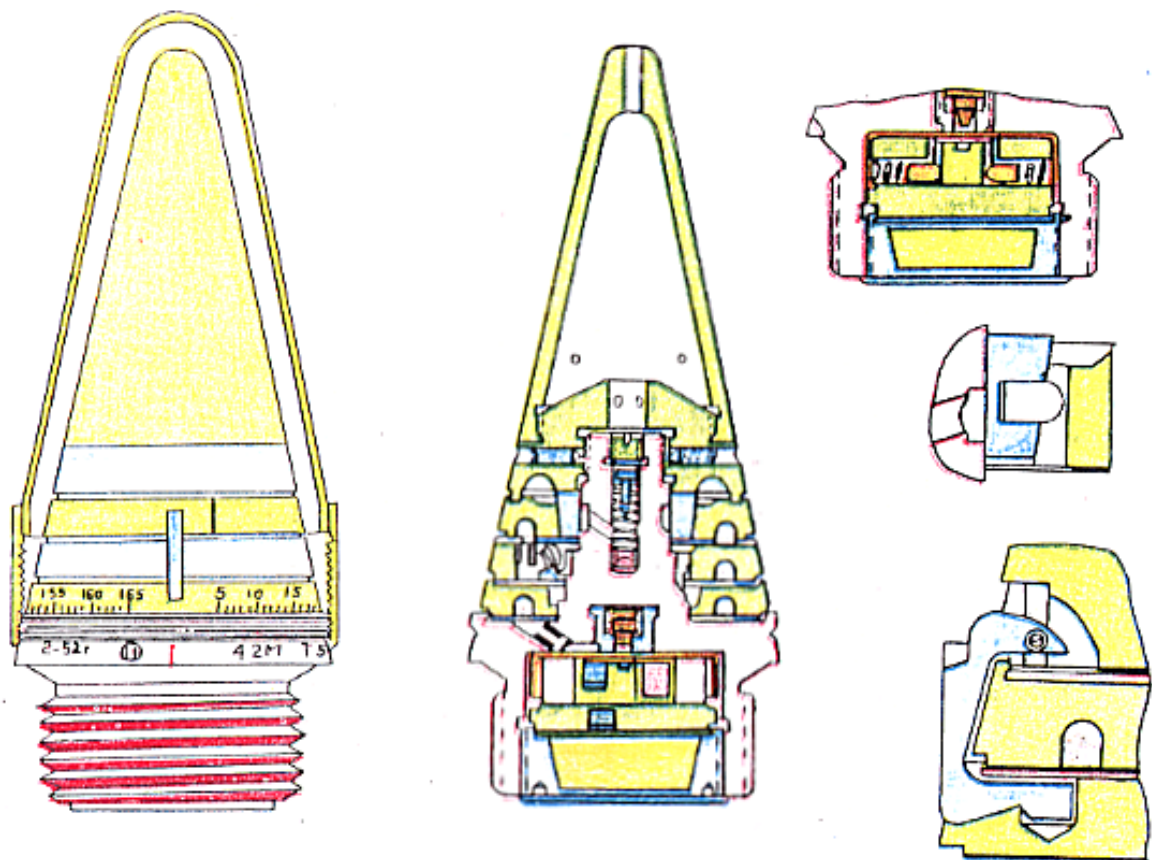
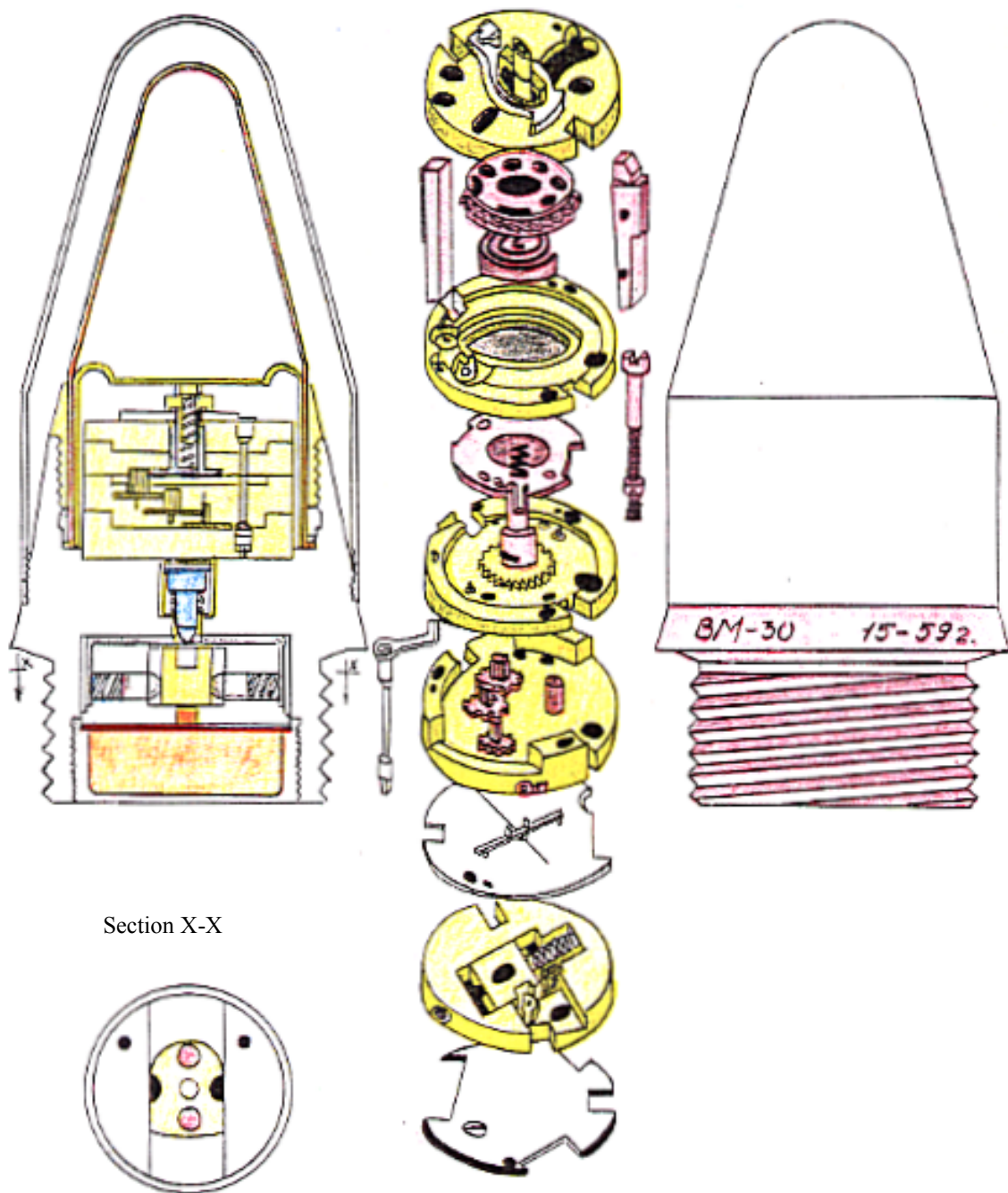

Figure 10-42 T-5 Fuze.



Section X-X

Figure 10-43 VM-30 Fuze.

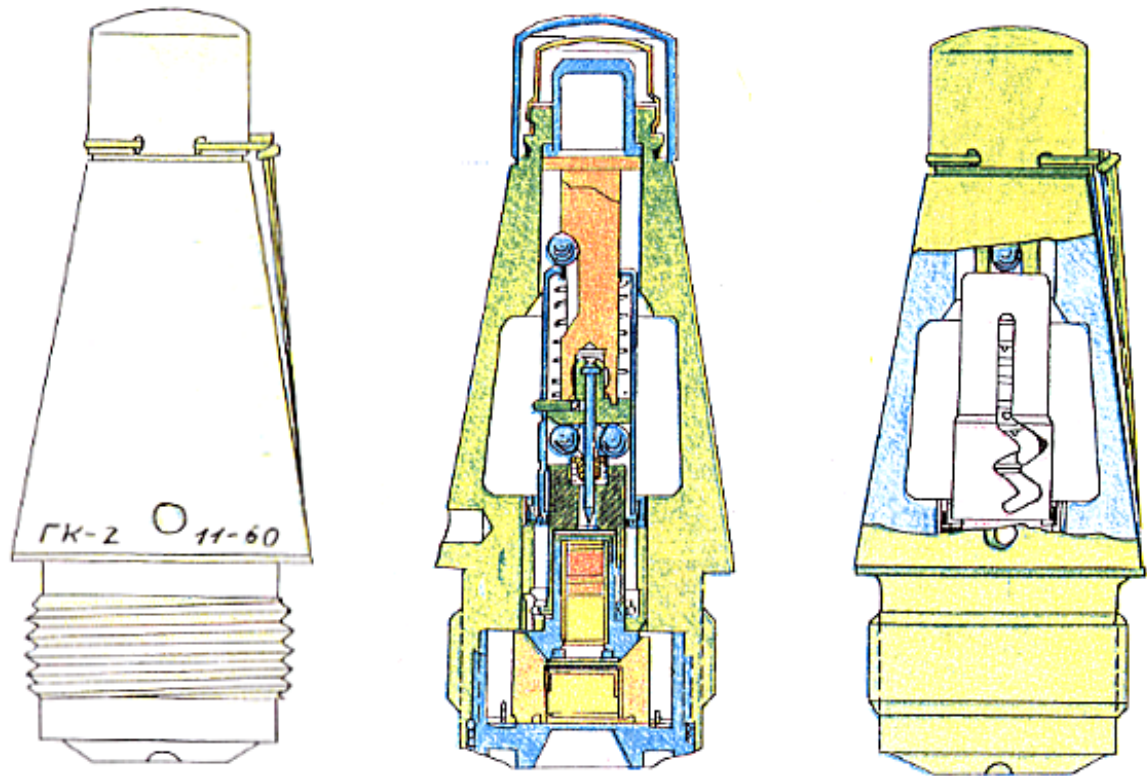

Figure 10-44 GK-2 Fuze.

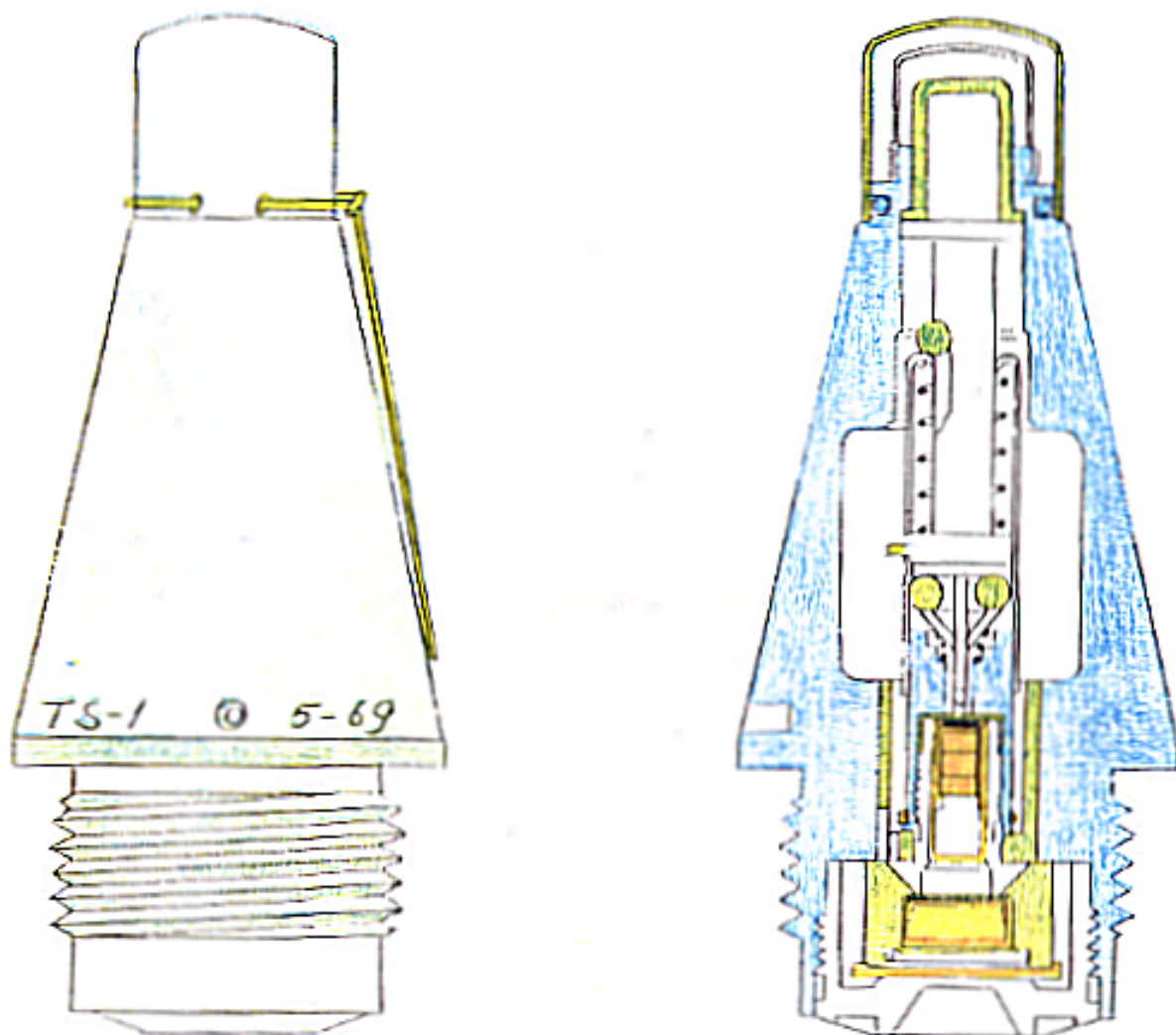

Figure 10-45 TS-1 Fuze.

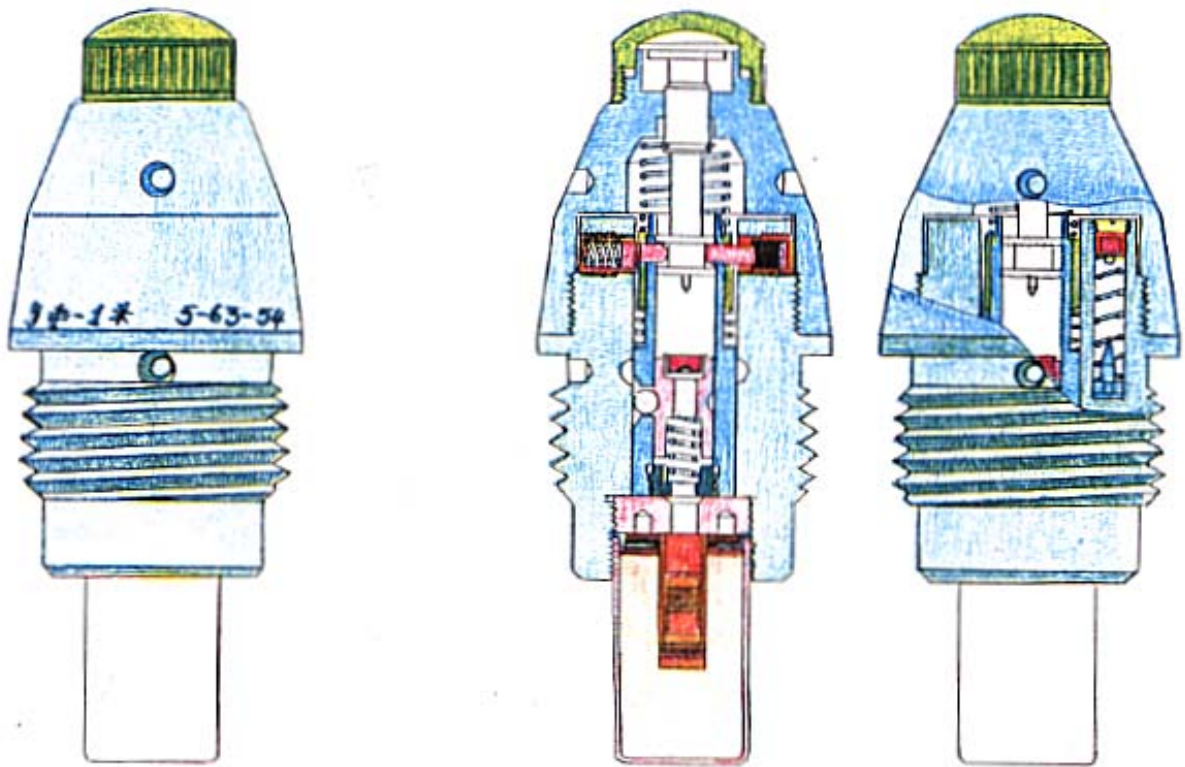

Figure 10-46 K-1 Fuze.

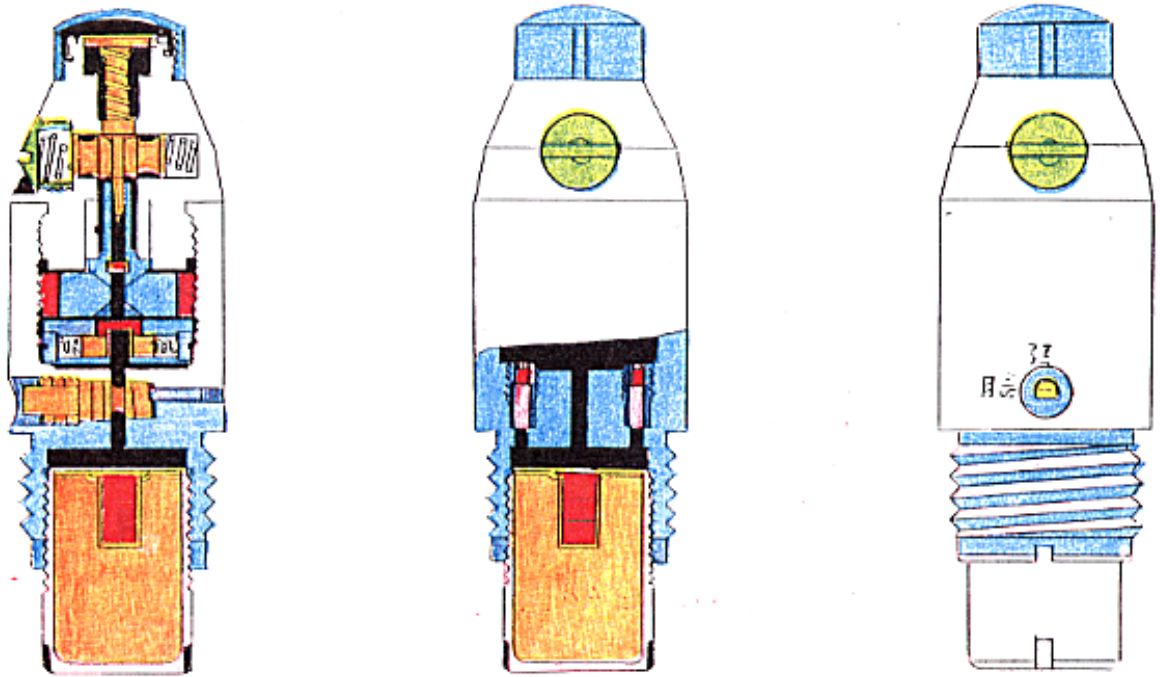

Figure 10-47 DMK Fuze.

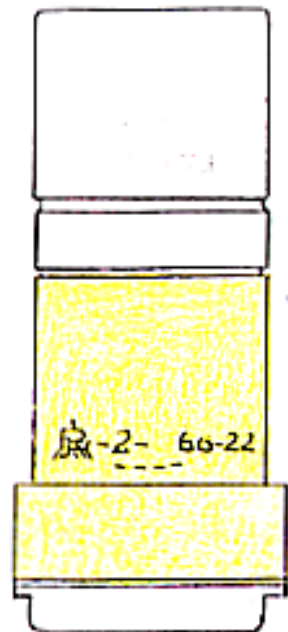
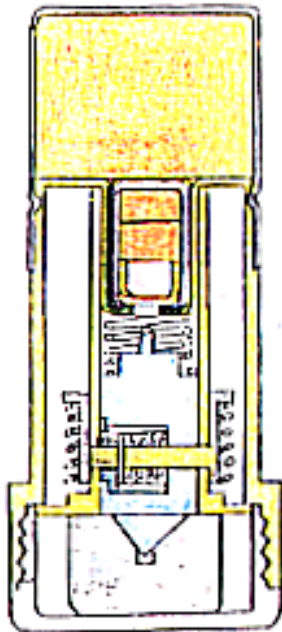

Figure 10-48 Fuze for shaped charge shell for 40 mm. grenade launcher (light) model 56.

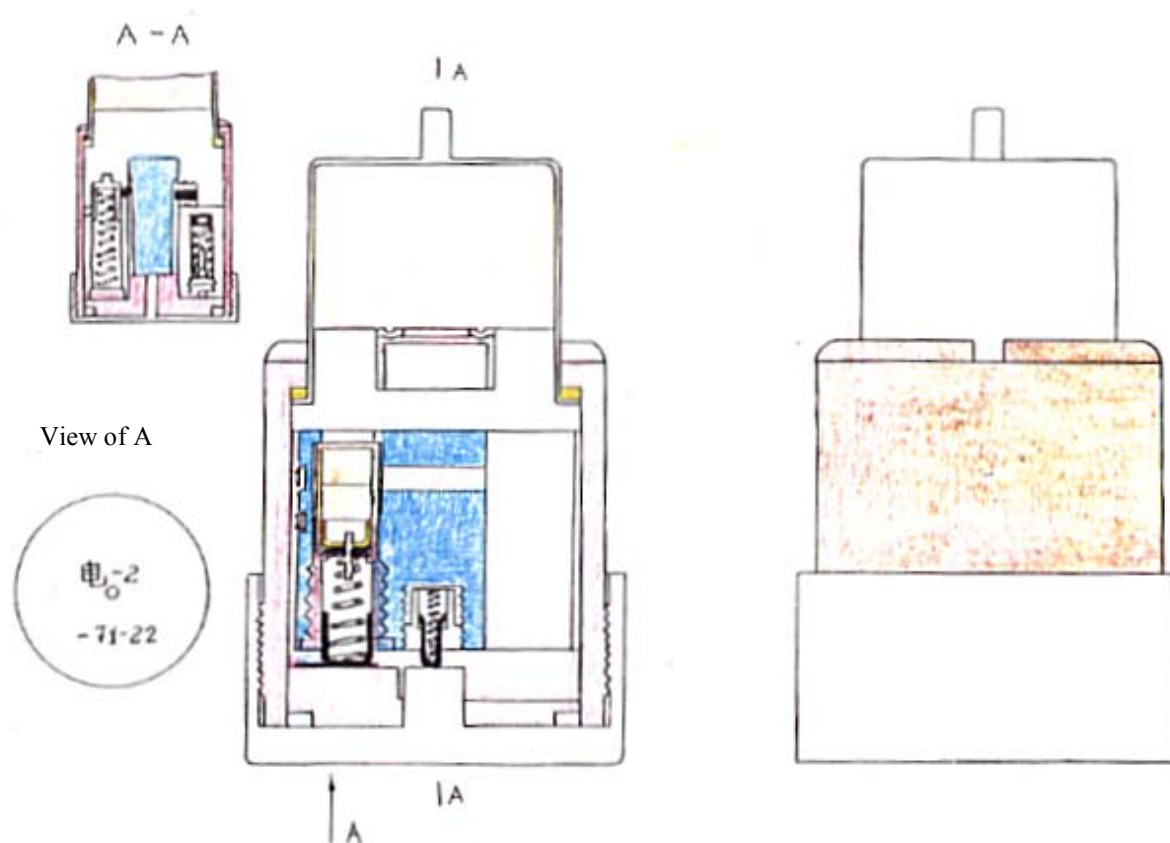

Figure 10-49 Fuze for shaped charge shell for 40 mm. grenade launcher (light) model 69.

CONTENTS

Preface	5
---------	---

PART I

COMPONENTS AND USE OF MUNITIONS

Chapter I. General information

1.	Types and construction of artillery munitions	16
2.	Principles of location of indicators on munitions, and key to these.	33
3.	Colour coding of munitions.	64

Chapter II. Munitions for artillery weapons

1.	Munitions for 23 mm. aircraft cannon.	66
2.	Munitions for 25 mm. AA gun model 1940.	68
3.	Munitions for 25 mm. naval gun.	70
4.	Munitions for 30 mm. aircraft cannon.	72
5.	Munitions for 37 mm. aircraft cannon.	74
6.	Munitions for 37 mm. guns:	75
	Single-barrelled AA gun (1939 and 1955 models.)	
	Twin-barrelled AA gun (1965 model.)	
	Naval gun.	
7.	Munitions for 45 mm. guns:	76
	Anti-tank gun (1939 and 1942 models.)	
	Naval gun.	
8.	Munitions for 57 mm. AA gun (1958 model.)	79
9.	Munitions for 76 mm. guns:	80
	Field gun (1942 (54)) model.	
	SP gun	
	Regimental gun (1943 model.)	
10.	Munitions for 85 mm. guns:	83
	Field gun (1956 model.)	
	Tank-mounted gun.	
	AA gun.	
	Naval gun.	
11.	Munitions for 100 mm. gun:	87
	Field gun (1954 (1944) model.)	
	AA gun (1959 model.)	
	Tank- mounted and SP gun.	
	Coastal artillery gun with mechanical extraction.	
12.	Munitions for 122 mm. howitzer (1954 (1938) model.)	93
13.	Munitions for 122 mm. gun (1960 model.)	96
14.	Munitions for 130 mm. coastal artillery gun with mechanical extraction.	98
15.	Munitions for 130 mm. coastal artillery gun (separate loading).	100
16.	Munitions for 130 mm. field gun (1959 and 1959-1 models.)	102
17.	Munitions for 152 mm. howitzer and gun-howitzer.	104

Chapter III: Munitions for recoilless guns.

1.	Munitions for 75 mm. recoilless gun, 1956 and 1956-2 models.	111
2.	Munitions for 82 mm. recoilless gun model B-10.	113
3.	Munitions for 107 mm. recoilless gun model B-11.	115

Chapter IV: Munitions for Grenade launchers

Munitions for Grenade launcher (light) 1956 model and 1969 model	116
--	-----

Chapter V: Mortar Munitions

1.	Munitions for 60 mm. mortar (model.63)	118
2.	Munitions for 82 mm. mortar (1937, 1941 and 1953 models.)	121
3.	Munitions for 107 mm. mortar (1938 model.)	125
4.	Munitions for 120 mm. mortar (1938,1943 and 1955 models.)	126
5.	Munitions for 160 mm. mortar (56 model.)	129

Chapter VI: Barrel launched rockets

(107 mm. rocket launcher (1963 model,) 130 mm. SP launcher (1964 model) and ML-13 SP launcher.)	132	
1.	Rockets	133
2.	Packaging of rockets	133

Chapter VII: Small arms ammunition: pistols, rifles and automatic rifles, light, heavy and AA machine-guns.

1.	Pistol rounds.	134
2.	Rounds for 7.62 weapons (56 model): rifle, automatic rifle and light machine gun.	135
3.	Rounds for 7.62 weapons (53 model): rifle, light and heavy machine guns.	136
4.	12.7 mm. rounds.	137
5.	14.5 mm. rounds.	138

Chapter VIII: Hand grenades.

1.	Anti-personnel hand grenades.	140
2.	Anti-tank hand grenades.	141

Chapter IX: Signal and illumination rounds	142
---	-----

Chapter X: Characteristics and use of shell fuzes

1. Fuzes for mortar bombs.	143
2. Fuzes for ground artillery shells.	145
3. Fuzes for AA artillery and aircraft cannon shells.	148
4. Fuzes for projectiles: recoilless guns, and for rocket and grenade launchers.	150

PART II

Drawings of munitions for artillery weapons with rifled barrels	152
---	-----

PART III

Drawings of munitions for recoilless weapons.	247
---	-----

PART IV

Drawings of munitions for grenade launchers.	259
--	-----

PART V

Drawings of mortar munitions.	266
-------------------------------	-----

PART VI

Drawings of munitions for reactive weapons.	281
---	-----

PART VII

Drawings of small arms ammunition.	288
------------------------------------	-----

PART VIII

Drawings of hand grenades.	307
----------------------------	-----

PART IX

Drawings of illumination and signal rounds.	320
---	-----

PART X

Drawings of fuzes.	329
--------------------	-----

THE END