

UNCLASSIFIED

AD NUMBER

AD114994

CLASSIFICATION CHANGES

TO: unclassified

FROM: secret

LIMITATION CHANGES

TO:  
Approved for public release, distribution unlimited

FROM:  
Controlling DoD Organization: Office of Naval Research, Arlington, VA 22217.

AUTHORITY

Office of Naval Research ltr dtd 28 Jul 1977; Office of Naval Research ltr dtd 28 Jul 1977

THIS PAGE IS UNCLASSIFIED

---

**NOTICE: THIS DOCUMENT CONTAINS INFORMATION AFFECTING THE NATIONAL DEFENSE OF THE UNITED STATES WITHIN THE MEANING OF THE ESPIONAGE LAWS, TITLE 18, U.S.C., SECTIONS 793 and 794. THE TRANSMISSION OR THE REVELATION OF ITS CONTENTS IN ANY MANNER TO AN UNAUTHORIZED PERSON IS PROHIBITED BY LAW.**

---

**F C**

NO. 114994  
FILE COPY

Key to: -  
Office of Naval Research  
Code 40215

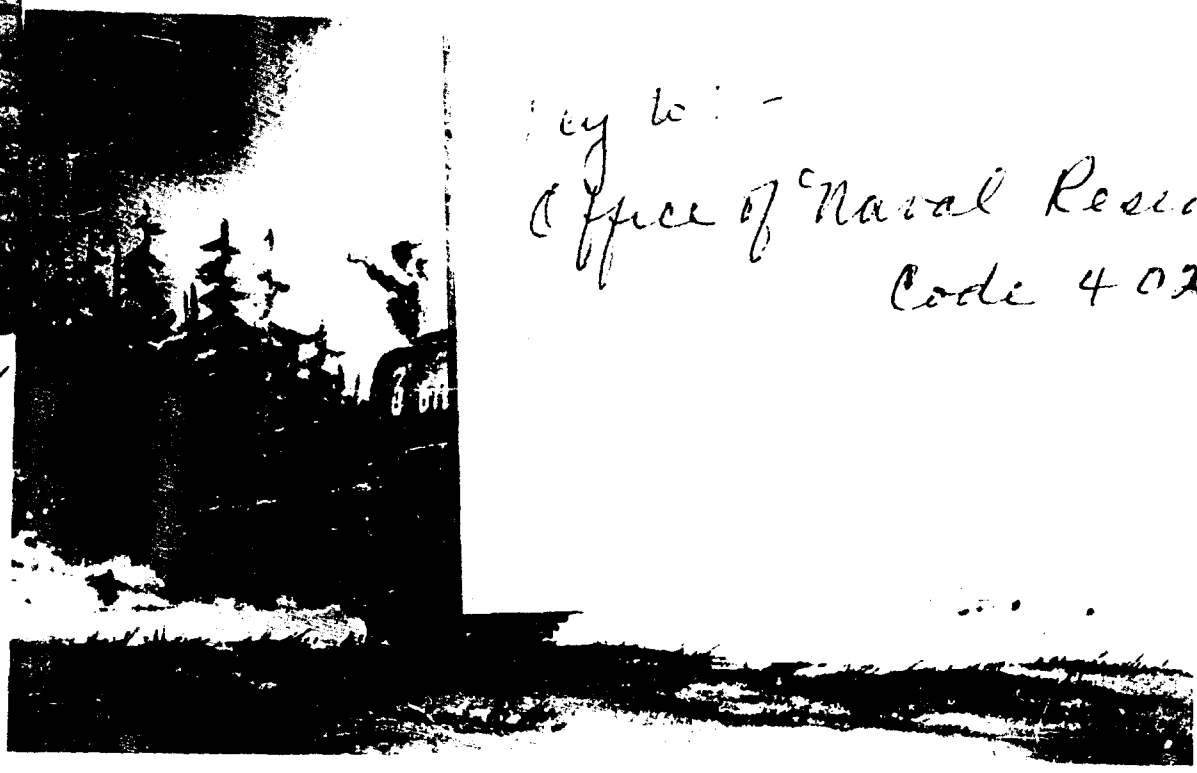

AD 114994

# AERIAL DELIVERED ANTI-TANK MINE

REPORT NO. ES 17942

COPY NO. 7

DEC 10 1956

61225

DOUGLAS AIRCRAFT COMPANY, INC., EL SEGUNDO DIVISION, EL SEGUNDO, CALIFORNIA

(11) (1) 1360

# **AERIAL DELIVERED ANTI-TANK MINE**

**Contracts Nonr 936(00) & Nonr 1492(00)**

**Report No. ES 17942**

**Copy No. 7**

**9 May 1955**

This document contains information affecting the national defense of the United States within the meaning of the Espionage Laws, Title 18 U.S.C. Sections 793 and 794. Its transmission or the revelation of its contents in any manner to an unauthorized person is prohibited by law.



**DOUGLAS AIRCRAFT COMPANY, INC., EL SEGUNDO DIVISION, EL SEGUNDO, CALIFORNIA**

**SECRET**



## DESCRIPTION

The Aerial Delivered Anti-Tank Mine was developed as a highly mobile weapon to exploit the potential of mine warfare in offensive-type operations. Aerial delivered mines are ideally suited for use beyond a beachhead perimeter or enemy front lines to prevent the enemy from bringing in heavy armor. The mine may be used in any tactical situation, offensive or defensive, where it is desirable to deny enemy armor access to local areas. The mine incorporates provisions for non-destructive sterilization which may be preset for any predetermined time up to 10 days. This sterilization feature permits friendly armor to pass through the mined area after the mine has served its purpose. Improvement studies indicate that a maximum sterilization time of six months is highly feasible. It is also possible to provide friendly vehicles with inexpensive equipment which will permit safe passage of the mined area at any time.

After separation from the delivery airplane the mine falls to earth and comes to rest beneath the surface in a near vertical position. The mine may be used in soils varying from wet clay to sand and hard packed soil surfaces. The depth of burial varies from 6 inches to 4 feet depending on the air drop and soil conditions.

The mine, as developed, incorporates a combined magnetic and seismic influence type fuze which fires a 6-inch diameter shaped charge. Tests indicate that the charge will penetrate more than 2 inches of armor after passing through 4 feet of earth and an 18-inch air gap.

The mine will incorporate anti-tampering or anti-withdrawal devices which will detonate the main charge even after the fuze is rendered safe by the sterilization network.

The fuzing system is adaptable to the addition of vehicle counters and other mixed package devices which will further complicate countermeasures.

The design and construction of the mine is in accordance with the requirements of modern aerial munitions and is ideally suited to the new "vertical envelopment" techniques of warfare.

## EXTERNAL CHARACTERISTICS

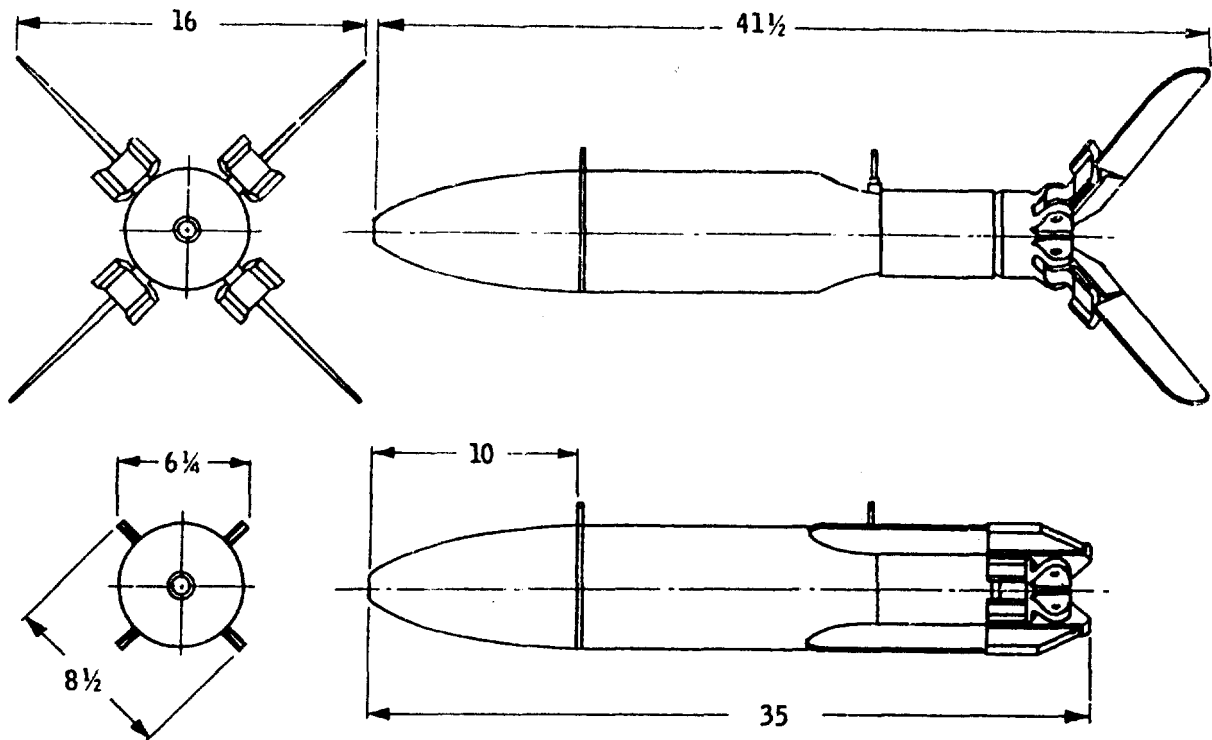

The nose shape is designed for minimum soil entry disturbance and for low peak deceleration of the unit. Field tests indicate that the desired results have been achieved.

Ground brakes are provided which limit soft soil burial depth to 4 feet. These brakes also serve to limit the terminal velocity of the air drop.

The stabilizing fins are of the folding type to permit maximum space utilization in shipping, storage and in delivery containers.

Weight of Complete Mine. . . . 57.3 pounds

## MILITARY CHARACTERISTICS

1. Single-shot hit-probability approximately 80%.
2. High producibility.
3. Low unit cost.
4. Very simple field check-out tests.
5. Rapid unit-type field assembly.
6. Suitable for air drop from any standard bomb-rack-equipped aircraft either individually or in clusters.
7. Capable of high or low altitude drops.
8. Unit may be dropped "Safe" in an emergency.
9. Safety in shipment, storage, arming of aircraft, in-flight and diving drops equal in all respects to established safety standards for aerial munitions.
10. Mine is capable of one year outside storage.
11. Power source easily replaceable.
12. Capable of causing crippling or lethal damage to the heaviest armored vehicles.
13. Completely water-proofed.
14. Causes minimum disturbance to soil on impact.
15. Capable of entering soil types ranging from wet clay to dry sand and hard packed soils.
16. No electrical connections between mine and aircraft.
17. No specialized pilot training necessary for delivery of mines.
18. Capable of self-sterilization by a pre-set period of from twelve hours to ten days in fourteen increments.
19. Possesses maximum resistance to countermeasures and natural or man-made spurious firing signals.

## PRINCIPLES OF OPERATION



The mine is armed electrically and mechanically on impact with the ground. A 40-second delay network permits the mine to reach a static condition before the fuzing system becomes operable. The mine is then "hot" and will fire under the first heavy vehicle that passes over it.

A heavy vehicle traveling on the surface produces a local change in the earth's magnetic field and also imparts a seismic vibration to the ground. As the vehicle passes over the mine the local change in the earth's magnetic field is sensed by a coil on the afterbody of the mine. The seismic vibration created by the vehicle activates a sensitive seismic switch in the nose of the mine. The fuzing system transforms the combined magnetic and seismic action into an electrical impulse which automatically compensates for vehicle speed and fires the mine under the vehicle.

The individual action of either magnetic change or seismic vibrations will not activate the fuze. Both influences must be present, simultaneously and for a finite length of time. The mine's resistance to line charges, or equivalent clearing devices, is believed to be excellent.

# PHYSICAL ARRANGEMENT

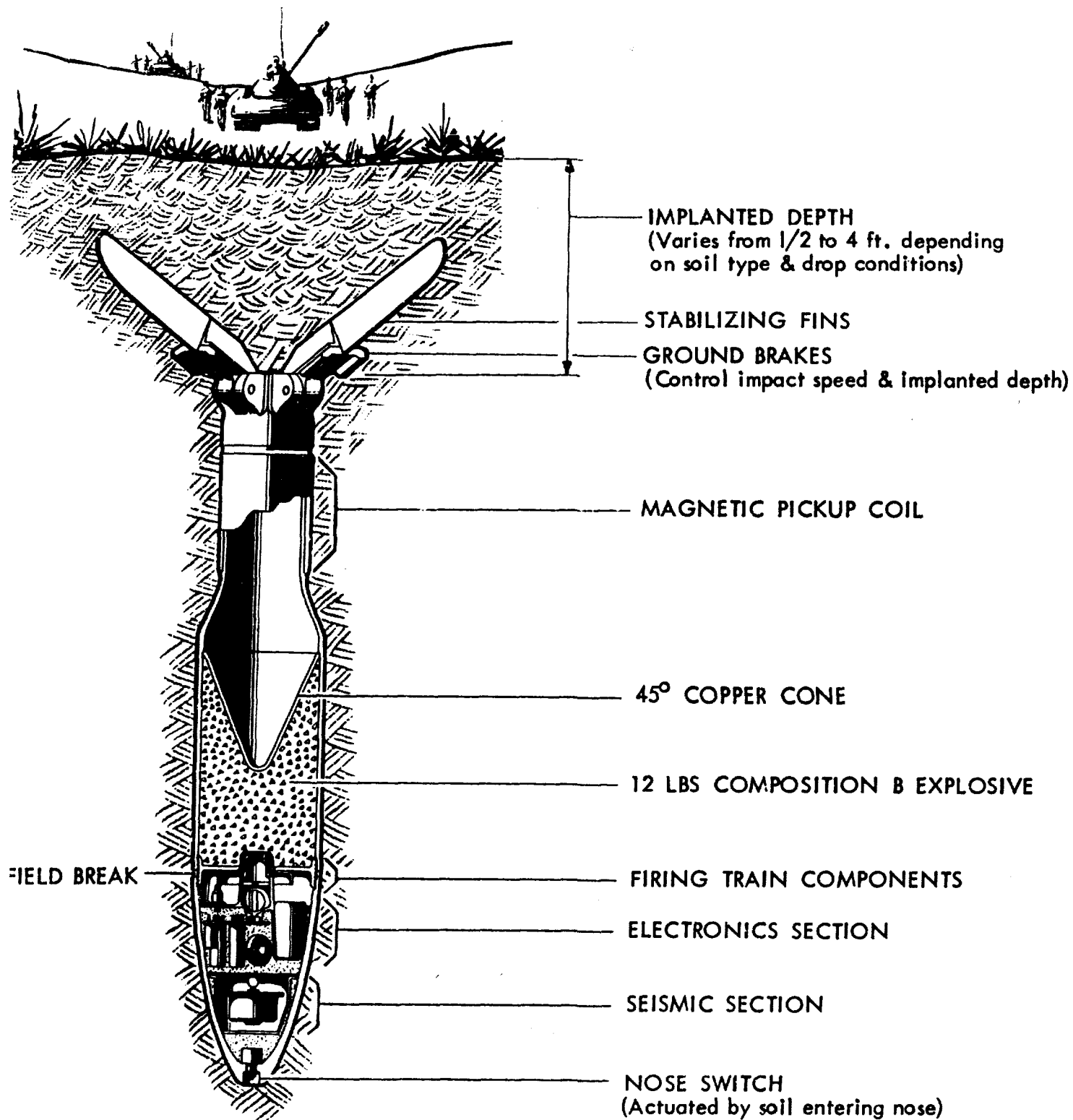

# DELIVERY

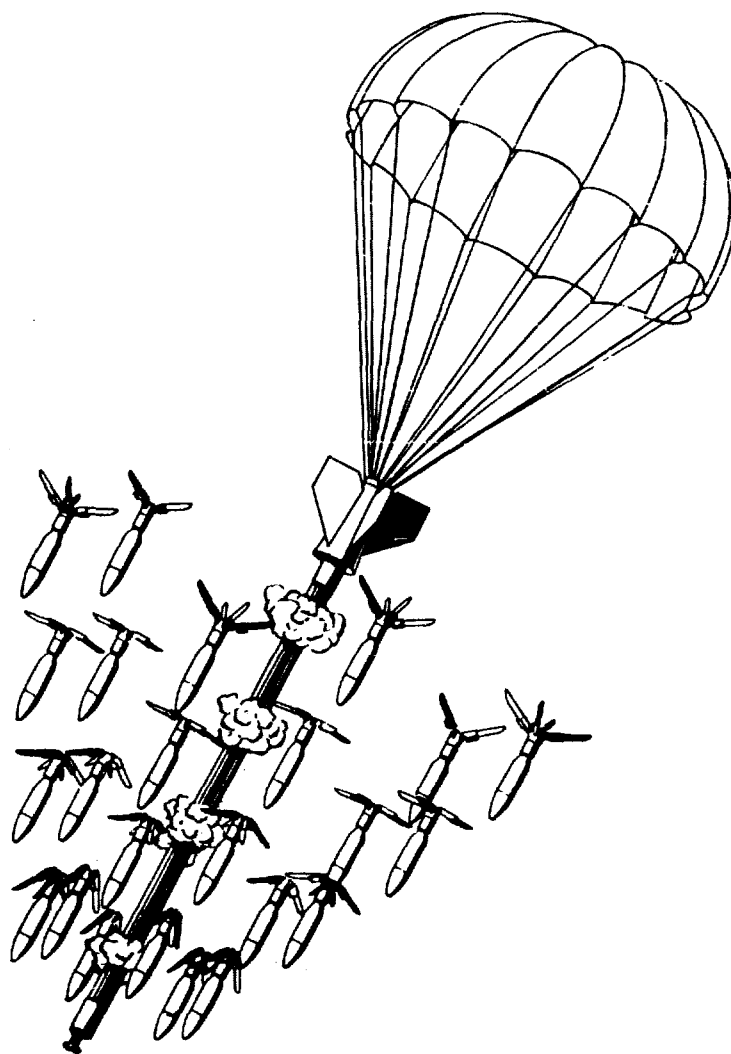
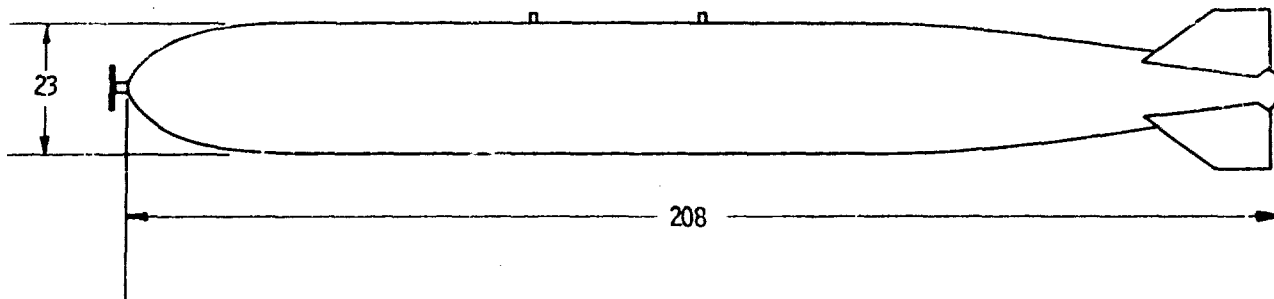

## CONTAINER

Tactical success of this weapon is largely dependent on the ability to utilize efficiently the carrying capacity of the delivery aircraft so that a large number of mines can be delivered effectively by a few airplanes.

The necessity of releasing the mines in a tight pattern at high speed eliminates the feasibility of a dispenser which stays on the airplane. The implanting density for the mine has been tentatively set by the Marine Corps at one mine per 100 square feet.

In order to utilize the directional effect of the shaped charge it is necessary that the mine be implanted in a nearly vertical position. This is accomplished by a high speed parachute which decelerates the container during the initial part of the drop. The container consists basically of a streamlined case for external carriage, a parachute to slow the cluster down so that the ground impact angle of the mines is within  $10^\circ$  of the vertical, and fuzing provisions which release the mines from the cluster at a pre-determined time after release from the airplane.

The weight of the complete container assembly, including 24 mines, is estimated at 1700 pounds. The container may be installed on any 2000 lb. class bomb station equipped with a 20 or 30-inch suspension system. Standard arming wire provisions will be incorporated so that the mines may be dropped "armed" or "safe". No special provisions or rework of the airplanes is required.

The current trend of external store stations indicates that multiple stations for rockets and small bombs are being replaced by 1000 lb. and 2000 lb. store stations which carry small ordnance items in packages. It is recommended that a secondary container in the 1000 lb. class also be considered. This container, incorporating the design features of the larger container, with provisions for 12 mines would weigh approximately 900 lbs. The Douglas A4D airplane with one 2000 lb. station and two 1000 lb. stations would carry one 1700 lb. container and two 900 lb. containers for a total of 48 mines per airplane. On airplanes of the Douglas AD Series, with three 2000 lb. store stations, it is possible to carry three 1700 lb. containers or a total of 72 mines per airplane.

## DELIVERY TECHNIQUES

The major mine-implanting requirements which must be considered in selecting a delivery technique are pattern continuity, implanted angle and impact velocity. Every effort has been made to utilize the present capability of service aircraft without modification.

Pattern continuity; i.e., the correct implanted relationship of mines from one airplane to mines dropped from other airplanes, can best be maintained by simultaneous formation drops. The use of a formation drop procedure eliminates the necessity of pin-point location of the mines from each airplane, and permits pre-selection of the desirable pattern to meet a specific tactical requirement.

A study of the possible delivery techniques indicates that level flight release and dive release are both practical if the formation drop procedure is used.

The level flight release would require the use of a simple line-of-sight device on the lead airplane. This procedure has been used in Special Weapons applications and there is every indication that the system can be adopted to the Aerial Delivered Anti-Tank Mine with the very minimum of airplane modification. Dive release presents a delivery method which would require no airplane modification if an offset aiming point is used. Aerial reconnaissance of the area to be mined would provide adequate information to permit the dropping of a coordinated pattern of mines with an accuracy of approximately 200 feet.

The adjacent figures present the pertinent trajectory data for the two methods of delivery. It will be noted that for both methods of delivery the impact velocity and implantation angle are changed very little by a large change in release speed. The striking velocity can be increased by removing the ground brakes which would not significantly affect the range of angle of impact. Therefore, in the final analysis, a delivery method and weapon configuration can be selected to give the proper penetration based on the soil conditions in the target area.

# TRAJECTORY CHARACTERISTICS

## RANGE - LEVEL RELEASE

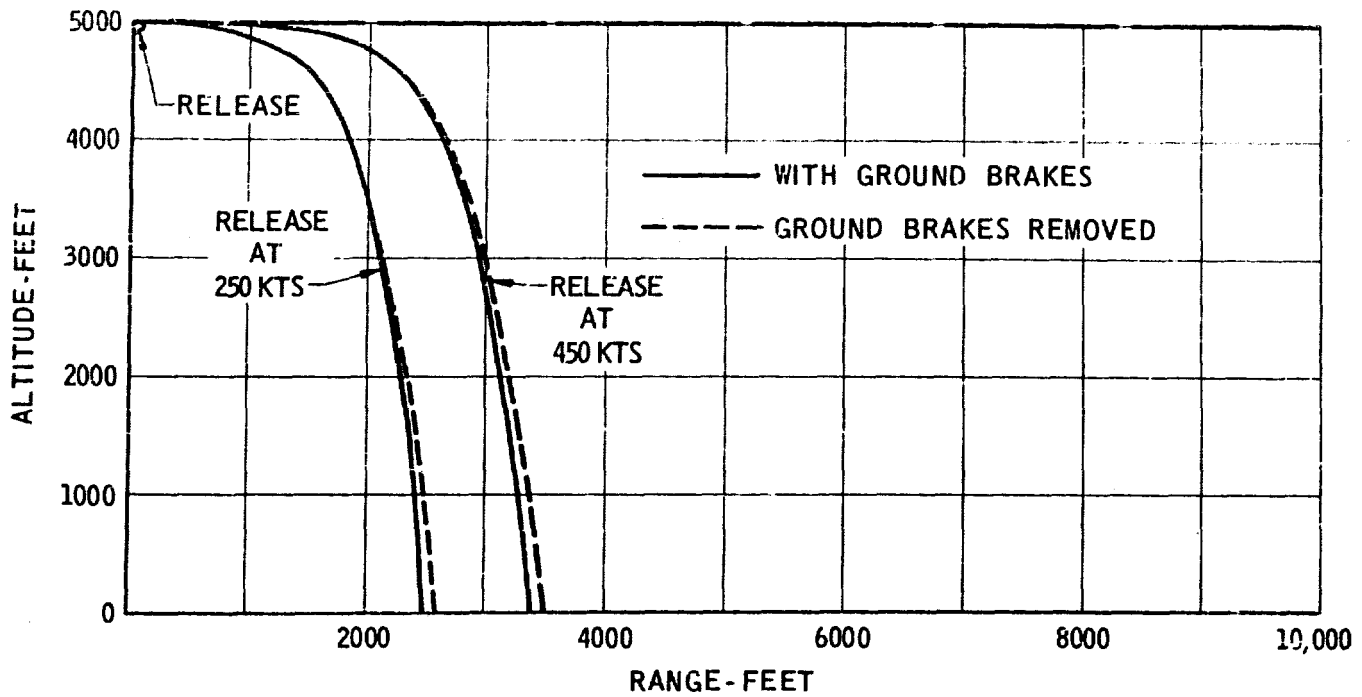

## RANGE - 50° DIVE

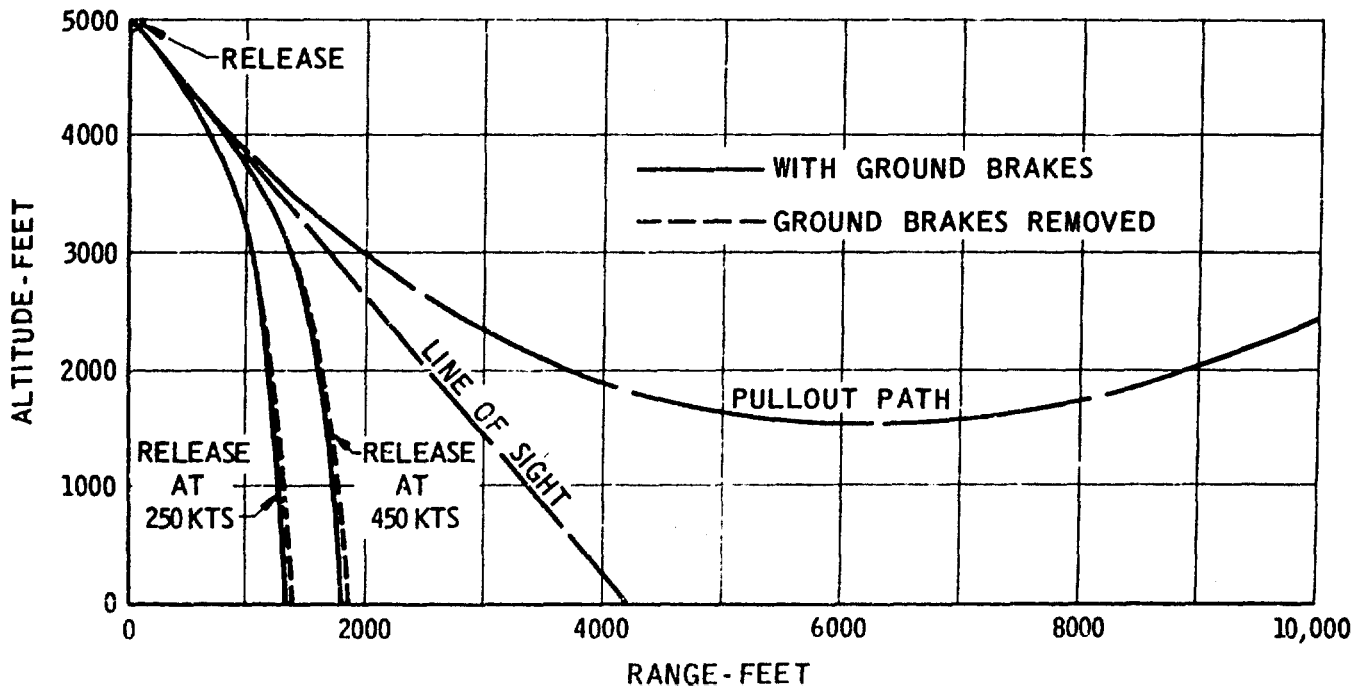

# TRAJECTORY

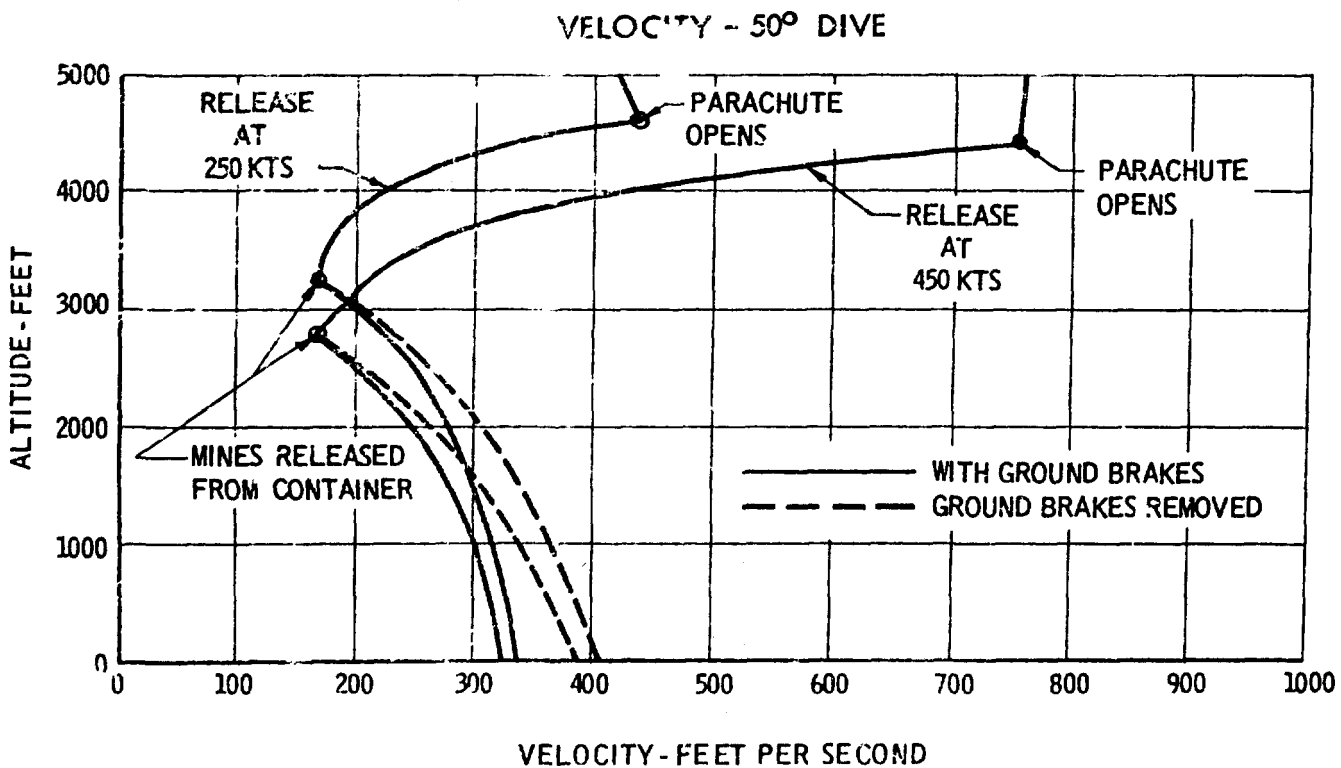
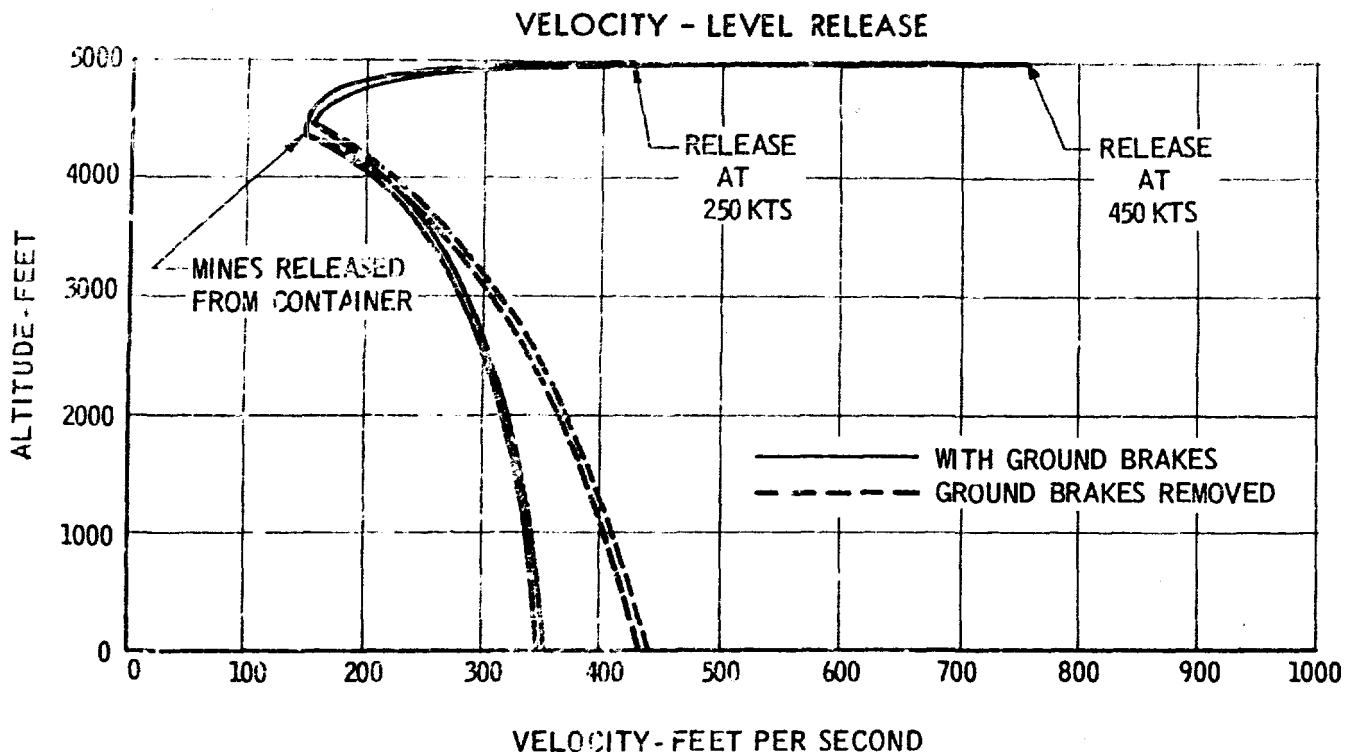

# CHARACTERISTICS

ANGLE FROM HORIZONTAL - LEVEL RELEASE

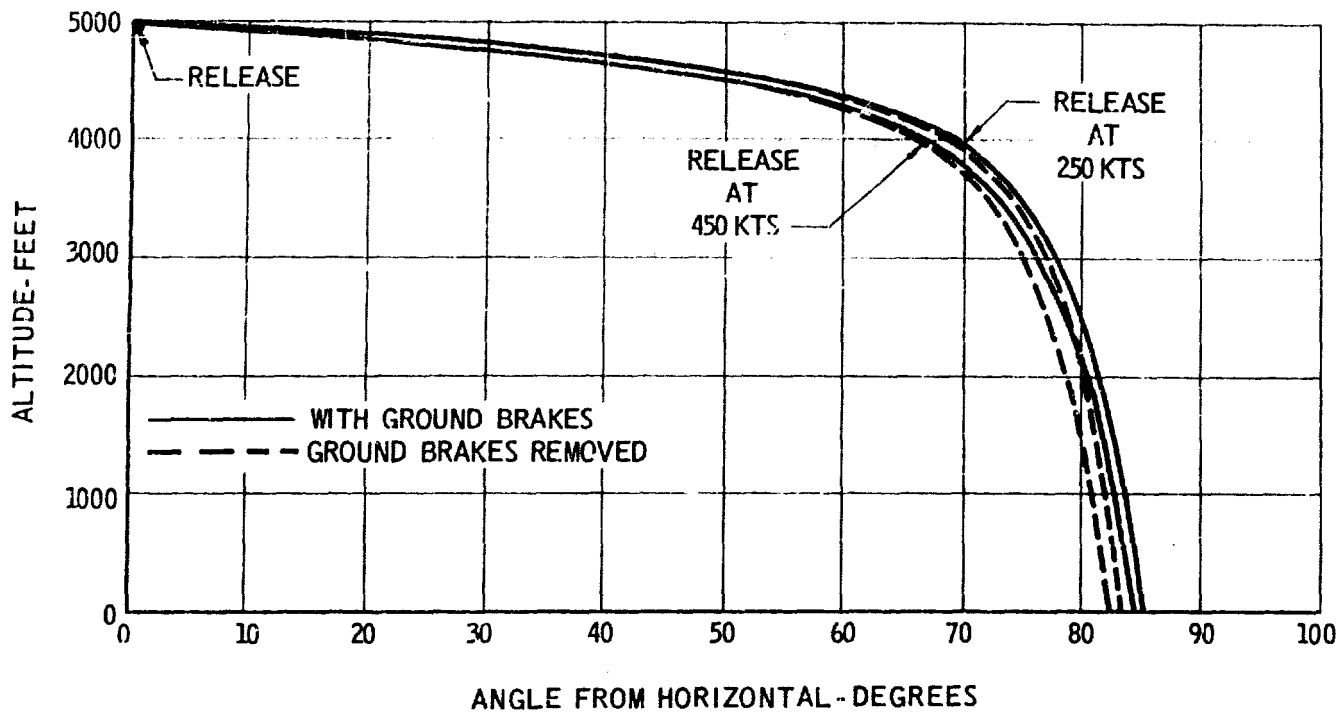

ANGLE FROM HORIZONTAL - 50° DIVE

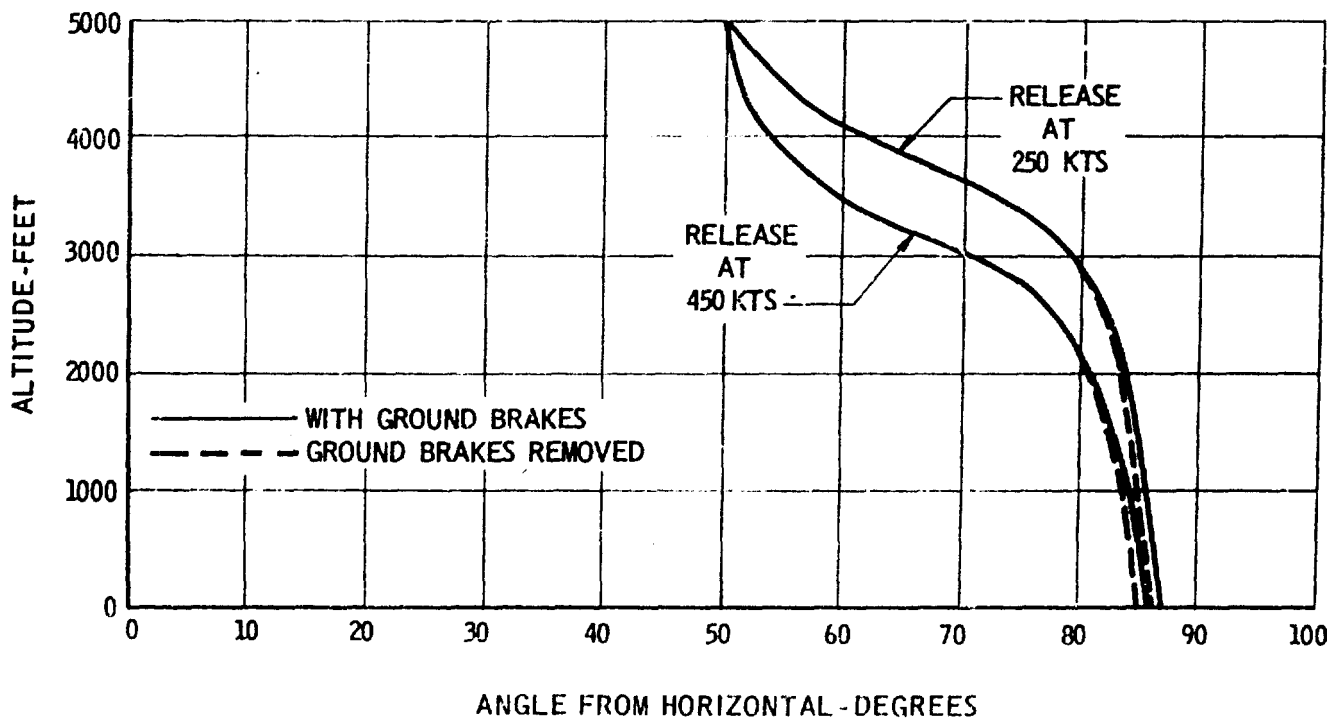

SECRET

## TYPICAL INSTALLATIONS

AD SKYRAIDER

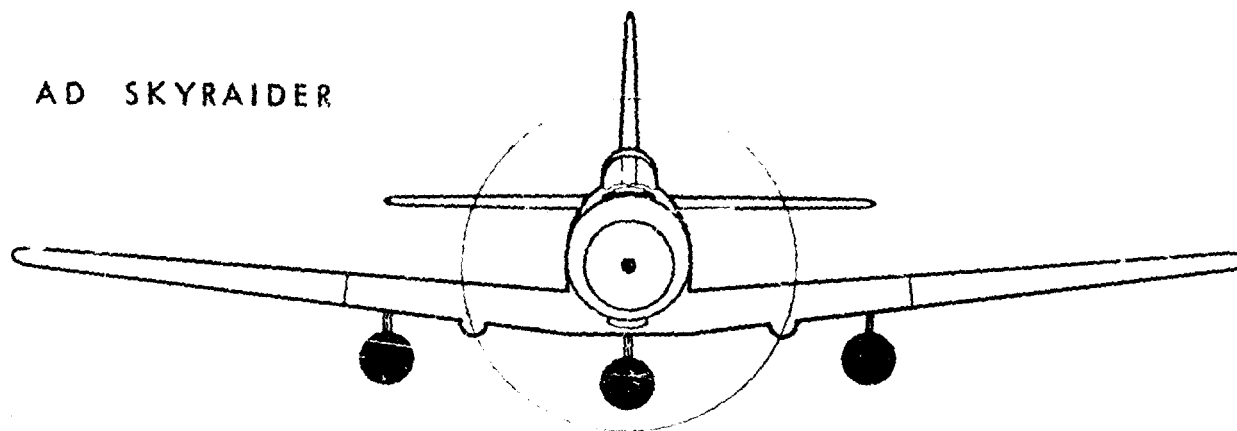

Three 1700 lb. containers (24 mines each) may be carried on AD type aircraft, or a total of 72 mines.

A4D SKYHAWK

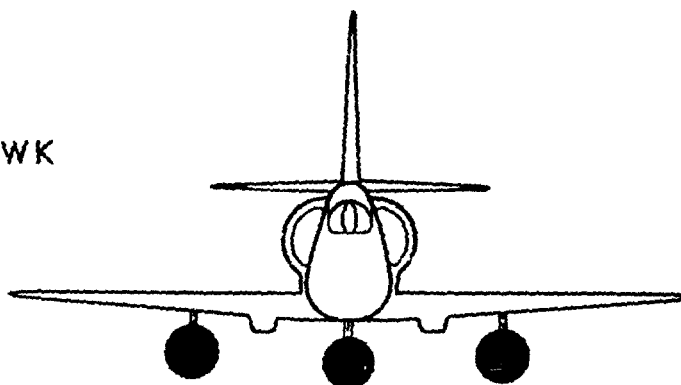

The A4D Skyhawk may carry one 1700 lb. container (24 mines) on the centerline bomb rack and two 900 lb. containers (12 mines each) on the wing bomb racks, or a total of 48 mines.

SECRET

## FIELD HANDLING AND ASSEMBLY

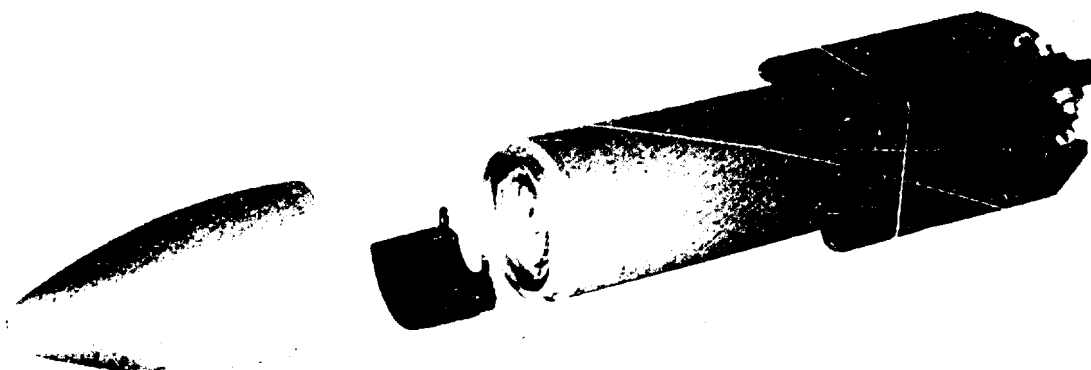

The Aerial Delivered Anti-tank Mine is designed for maximum safety in the handling and storage of explosive components and for simplicity of field assembly. The mine may be handled and stored as three basic components; (1) the nose assembly containing the fuze and firing train; (2) the battery power pack and (3) the main body assembly containing the explosive charge.

Field assembly consists of inserting the battery power pack into the nose assembly and screwing the nose assembly to the main body. No special training or tools are required.

The sterilization setting may be made after assembly and is the only adjustment on the unit.

There are no electrical connections to the airplane. The mechanical arming system is in accordance with standard airborne munition practices.

## PRODUCIBILITY

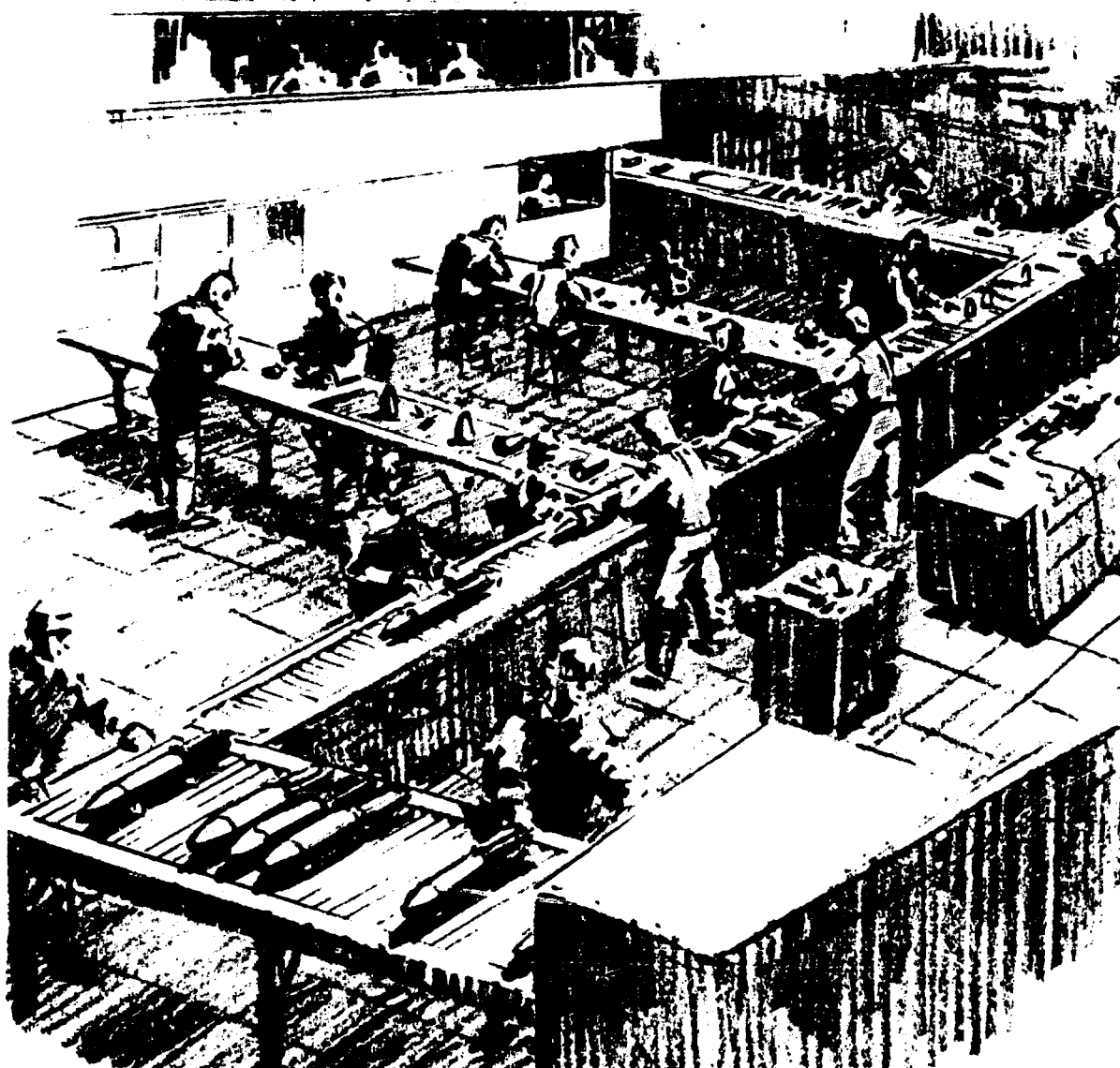

This unit lends itself to fast continuous production as the majority of its components may be made on standard automatic machines with a minimum of specialized tooling .

Production is favored by independent sub-assemblies. Final assembly is a simple process of inserting sub-assemblies into the basic units and assembling them into a complete item. There is no special production tooling required for assembly.

Production is based on a 47-second cycle to deliver 1200 to 1400 units per day which will be accomplished on a single line in three shifts.



Noe Assembly

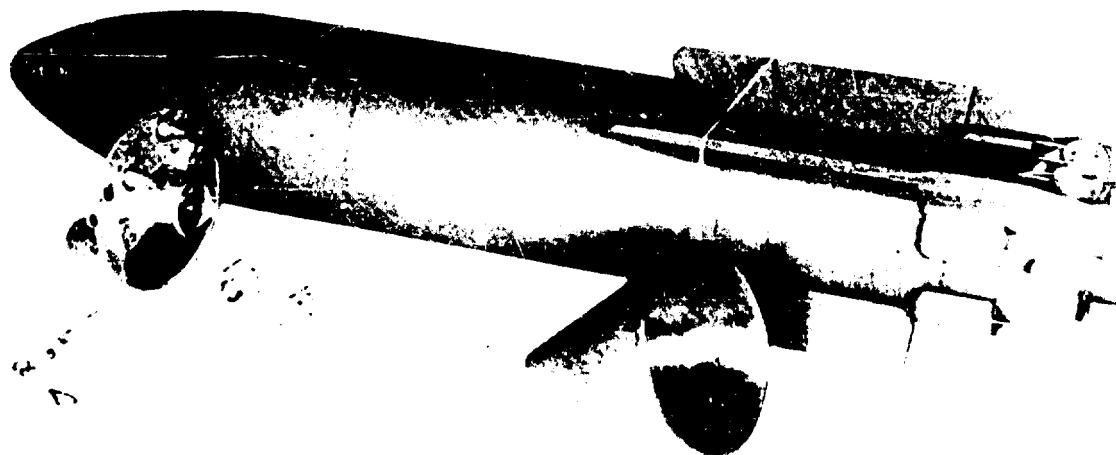

Firing Train Components

# ELECTRONICS UNITS

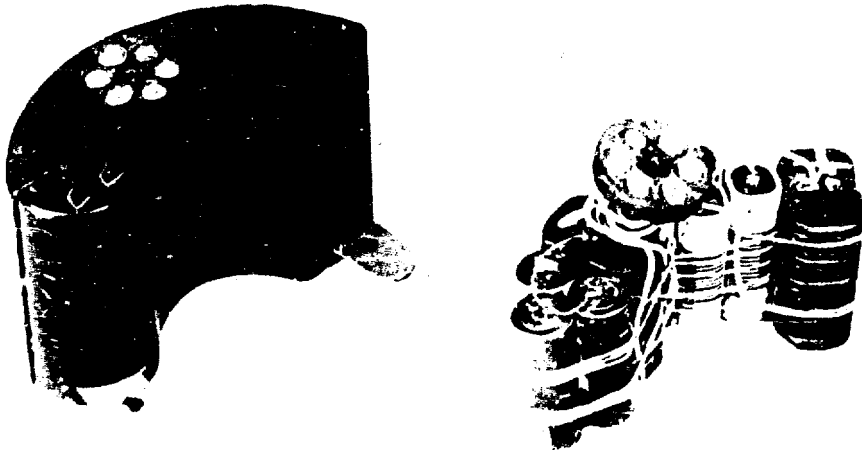

Battery Assembly - Potted and Unpotted



Electronics Assembly - Potted and Unpotted