

**ADVANCED  
FUZE &  
EXPLOSIVE  
ORDNANCE  
BULLETIN No. 13**

**FEBRUARY 1945**

**CONFIDENTIAL**

This document is issued to the graduates of the Bomb Disposal School and the Advanced Fuze & Explosive Ordnance course by the Officer-in-Charge, Navy Bomb Disposal School, under authority of Bureau of Ordnance letter F41-8(L) dated 22 April 1944. It is for information and guidance only and is not a Bureau of Ordnance publication. This document shall be destroyed by burning when it has fulfilled its purpose.

# TABLE OF CONTENTS

<u>ROCKETS</u>	<u>PAGE</u>
3"5 Rocket Flare	1
 <u>FUZES</u>	
Bomb, Fuze Tail, L.D.T., M123A1 Series - Modification to...	4
Bomb, Fuze Nose M135A1.....	6
Bomb, Fuze Nose M136A1.....	6
Bomb, Fuze Nose M139A1.....	5
Bomb, Fuze Nose M140A1.....	5
Bomb, Fuze Nose M142.....	5
Bomb, Fuze Nose M144.....	6
Bomb, Fuze Tail M150.....	6
Bomb, Fuze Tail M151.....	8
Bomb, Fuze Tail M152.....	10
Bomb, Fuze Tail M153.....	10
Bomb, Fuze Nose M155.....	11
 <u>MISCELLANEOUS</u>	
Status & Availability of Aircraft Bombs, Bomb Fuzes & Accessories...	13
5"/38 W.P. Smoke Projectile.....	30
Primer Detonator M14 - 0.24 Sec. Delay..	32
Use of Incendiary & H.E. Bombs Against Japanese Type Structures...	33
Multiple Suspension of Bombs.....	34
Igniter AN-M9 (WP) and (NA).....	35
Burster M18.....	36
Modification of Trunnion Band M5.....	36
Suggested Reading.....	38

# ROCKETS

C O N F I D E N T I A L

## 3"5 ROCKET FLARE

### INTRODUCTION

The 3"5 Rocket Flare has been developed for use from surface ships, particularly motor torpedo boats.

The illuminant candle produces an average of 800,000 C. P. for approximately 29 seconds. The rocket motor carries the flare out to a distance of 1800 yards before ignition and suspension of the flare. The complete round weighs 35 pounds and has an assembled length of approximately 47 inches.

At present the flare is under limited procurement and pending receipt of reports from the field, it will be available in limited quantities only.

### DESCRIPTION OF ROUNDS

#### 3"25 Motors Mk 12 Mod O, Mk 14 Mod O and Mk 14 Mod 1, Fig. 1

These three motors are essentially the same and are interchangeable. However, the Mk 14 Mod 1 will probably become the standard item of issue. Its principal distinguishing feature is the use of welded-on launcher lugs replacing the lug bands employed on the earlier models. The motor housing is a 3"25 seamless steel tube containing a forward closure disc, igniter Mk 11 Mod O, tubular ballistite grain Mk 7 Mod 1 (0.8 lbs), steel grid, welded nozzle, and pigtail. Four tail fins, 3 inches by 8 inches, are mounted on a sleeve fixed to the after end. A thread protector on the forward end and a shipping cover taped on the after end protect the motor in shipment. Motors Mk 12 Mod O and Mk 14 Mod O do not have a shipping cover on the after end.

#### 3"50 Bodies Mk 10 Mod O, Mk 14 Mod O and Mk 15 Mod O, Fig. 1

The illuminant element, Rocket Body Load (Flare) Mk 7 Mod O, may be housed in any one of the three bodies listed above. All bodies are interchangeable and differ only in minor details. The body Mk 10 Mod O has a wooden nose piece held in place by three shear pins while the Mk 14 Mod O and Mk 15 Mod O have a sheet metal nose piece press fitted in place. The body Mk 15 will probably be the production model and is 1 inch longer overall than the other two. The body consists of a 3"25 seamless steel tube which incorporates a 3"5 diameter motor adapter welded to the after end. This motor adapter carries a copper diaphragm plate with its firing pin and serves as a chamber for the Cal .32 blank cartridge which ignites the firing train of the flare. Just ahead of the adapter is the fuse, Mk 134 Mod O, which consists of a length of time fuse and a 20 gram charge of black powder. The balance of the body is taken up by the Rocket Body Load (Flare) Mk 7 which consists of the candle and parachute from the 4 inch illuminating projectile. The pyrotechnic composition of the candle has been altered to increase the candlepower with a slightly shorter burning time. The forward end of the body is closed by a metal cup pressed into place. The nose piece provides ogival contour at the forward end.

### OPERATION

When the rocket is fired, motor pressure builds up blowing out the forward closure disc and exerting its force on the diaphragm plate in the base of the motor adapter. The diaphragm collapses forcing the firing pin into the primer firing the blank cartridge. The flash from the cartridge ignites the time fuse which burns through, igniting the black powder charge. The flash from the black powder serves to ignite the illuminant candle, and as pressure builds up in the body, the metal closing cup is forced out, pushing or shearing the nose piece free, and the lighted candle is expelled and suspended from its parachute.

-1-

CONFIDENTIAL

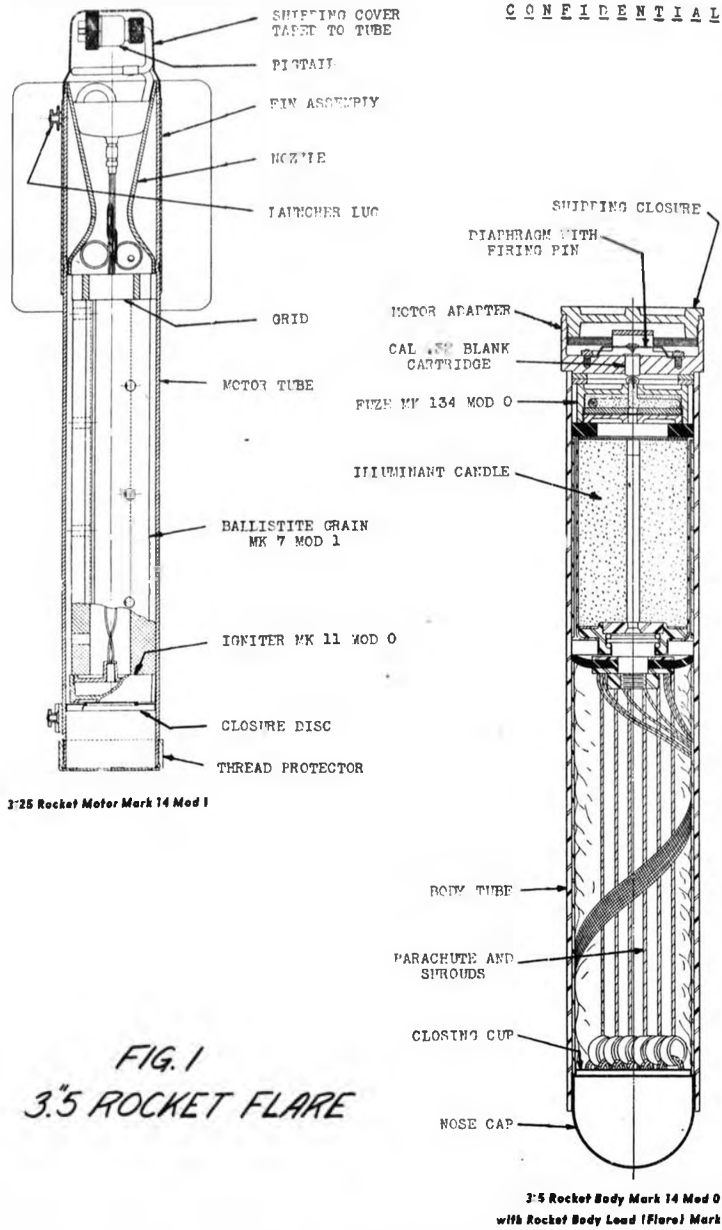

3.25 Rocket Motor Mark 14 Mod 1

FIG. 1  
3.5 ROCKET FLARE

3.5 Rocket Body Mark 14 Mod 0  
with Rocket Body Load (Flare) Mark 7

The Fuse Mk 134 Mod O is timed to give a delay of 15 seconds between firing of the rocket and suspension of the candle.

ASSEMBLY

Assembly of the rocket involves removing shipping covers from the motor and the thread protector from the body and simply screwing the two parts together securely. Observe care that the component parts are not damaged.

SHIPPING AND STOWAGE

Rocket motors and bodies are packed separately in wooden boxes. Four motors are packed in a box 11-3/4 x 13-3/8 x 30 inches weighing 93 pounds gross. Four bodies are packed in a box 8 x 8-1/2 x 25 inches weighing 74 pounds gross.

Motors should be stowed according to smokeless powder regulations. The bodies are pyrotechnic and should be stowed accordingly.

LAUNCHERS

To insure that ignition and ejection take place at sufficient altitude, the flare launcher should be set at approximately 38° elevation. This will permit a time of fall of at least 30 seconds.

The following surface launchers may be used:

- Mk 1 - See OP 1165
- Mk 30 - " OP 1135
- Mk 31 - " OP 1279
- Mk 34
- Mk 35 - See OP 1244
- Mk 36 - " OP 1318

PRECAUTIONS

Safe temperature limits for firing are given in markings on the motor tube. The usual precautions used in handling and firing rockets are to be observed.

-----  
REFERENCE: OP 1331

\*\*\*\*\*

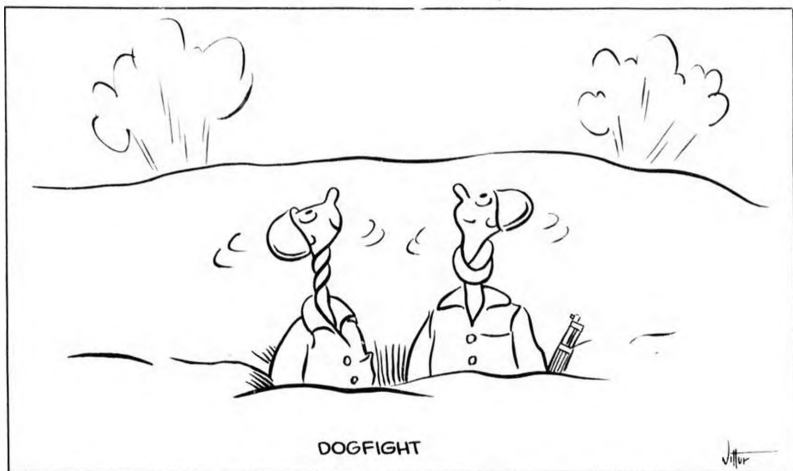

DOGFIGHT

# FUZES

R E S T R I C T E D

## LATEST MODIFICATION TO M123A1 SERIES TAIL FUZES

Recently the M123A1 long delay tail fuze series (described in AFEO Bulletin No. 10, page 11) was modified as shown in Fig. 2. The change consists of adding an ampoule retainer sealing cup made of gilding metal, a rubber sealing washer, set screw and lock nut. This modification assures more effective sealing, since the arming screw crushes but does not break through the ampoule retainer sealing cup. The set screw and lock nut hold the ampoule retainer in place and assure a tight fit against the retainer cup.

Current production of the M123A1 series long delay tail fuzes incorporates this modification. No new mod has been assigned.

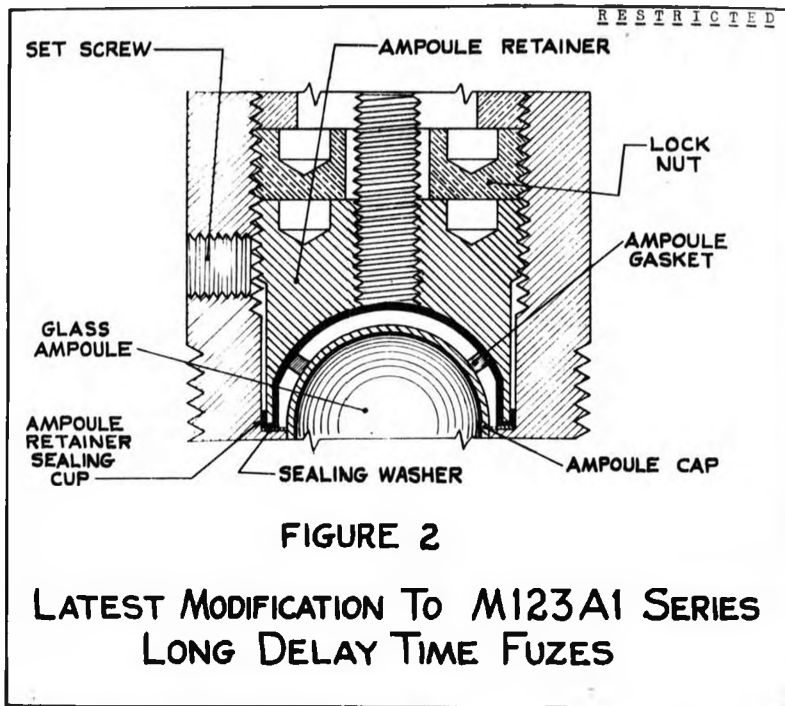

R E S T R I C T E D

### BOMB NOSE FUZES M139 AI & M140 AI

AFCO Bulletin No. 6, page 18, covered the M139 (T66) and M140 (T67) nose fuzes. It will be recalled that these fuzes are the same as the AN-M103 except that the M139 incorporates a .01 second delay and the M140 has a .025 second delay.

The M139AI and the M140AI are the same as the M139 and M140 respectively, except that they incorporate the widened arming screw found in the AN-M103AI, which makes them "crash proof".

In order to distinguish the M139, M139AI, M140, and M140AI from the AN-M103 or AN-M103AI fuzes, the former have the segments painted on the vane cup as shown in Fig. 3. The M139 and M139AI has a 1/8 black segment, and the M140 and M140AI a 1/4 segment.

The M139AI and M140AI are current production and replace the M139 and M140 respectively. These fuzes may be used as companion fuzes for the AN-M100A2 series using the M14 primer detonators with delays of .01 second or .025 second, for tactical situations requiring such delays.

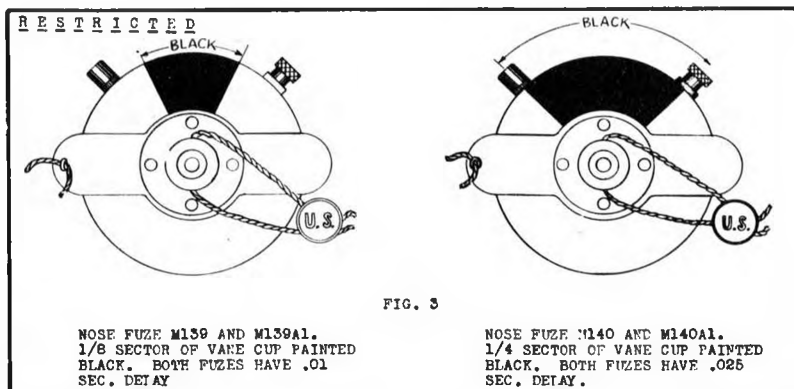

R E S T R I C T E D

### BOMB NOSE FUZE M142

Reference is made to AFCO Bulletin No. 5, page 13, covering the M3 fuze. The M142 all-ways action fuze supersedes the M3 all-ways action fuze. The M3 fuze was used in experimental production of the M74 incendiary bomb; however, it was found that the 1 to 2 second delay incorporated in this fuze was unnecessary, as the inherent delay would be sufficient. Therefore, it was redesigned and designated the M142.

The M142 fuze differs from the M3 as follows:

- (1) The M142 employs a #26 percussion primer instead of a M29 percussion primer.
- (2) The M142 has cavities in end of fuze case (center cavity and ring cavity) filled with 1 gram of fuze powder.
- (3) The M142 does not have a built-in delay charge as does the M3.
- (4) The M142 has a zinc booster cup containing 3 grams of propellant powder instead of the

-5-

cellulose nitrate booster cup containing  
1 gram of fuse powder in the M3.

Operation of the M142 is the same as the M3, the only  
difference being that the M142 does not incorporate a delay.

Current production of the M74 incendiary bomb incorporates  
the M142 nose fuze.

R E S T R I C T E D

### BOMB TAIL FUZE M150

AFEO Bulletin No. 9, page 17, describes and pictures the  
all-ways action type fuze M4 as used in the M77, 10-lb. Smoke bomb. This fuze  
has been redesignated, and is now known as, Bomb, Tail Fuze, M150. No change  
has been made in design.

R E S T R I C T E D

### BOMB NOSE FUZES M135 AI & M136 AI

It will be recalled that the primary difference between the  
Mechanical Time Nose Fuzes M135 and M136 is that the M135 has a setting range of  
5-92 seconds while the range of the M136 is 5-30.6 seconds.

A fuze setting on these fuzes of 6-10 seconds (which, of course,  
would be effective only in connection with low altitude releases) would be rela-  
tively dangerous to the releasing aircraft because there is a chance that it will  
be struck by fragments of its own bombs. To overcome this situation, the M135AI  
and M136AI fuzes will differ from the M135 and M136 respectively in that the mini-  
mum fuze setting will be ten (10) seconds instead of five (5).

With a minimum setting of ten (10) seconds, the bombs will  
be sufficiently clear of the releasing airplane so that no damage to it will  
result.

According to Army sources, the M135AI and M136AI fuzes will  
probably not be available in the field for some time. Until they are available,  
when using M135 and M136 fuzes, it is recommended that the minimum setting be no  
less than ten (10) seconds. Ordnance personnel should be cautioned to secure  
the time setting screw as tightly as possible to prevent the setting from slipping  
due to vibration in the airplane.

R E S T R I C T E D

### BOMB NOSE FUZE M144

#### DESCRIPTION

The M144 fuze (formerly the T64) shown in Fig. 4, is similar  
to the M128 (T55) described in AFEO Bulletin No. 8, page 21, except for the  
following:

Direct drive, instead of gear reduction arming, results  
in ejection of the safety blocks after approximately 6-9 turns of the  
arming vane. The direct drive involves the removal of the stationary  
gear from the arming hub, the movable gear from the arming sleeve, and  
the idler gear from its pin. The arming sleeve stop plate fixed to the  
bottom of the arming sleeve, has a fork which engages the idler gear pin  
and prevents the arming sleeve from rotating. This change was made to  
insure that the safety block is ejected in less than the mechanical  
functioning time of the fuze.

The M144 has a black powder booster instead of the full  
tetryl booster on the M128. In addition, the M144 incorporates a clock  
mechanism which runs 3 times as fast as the M128 clock mechanism. This  
results in a minimum setting of 1.6 seconds (instead of 5), a maximum  
setting of 30.6 seconds (instead of 92), and a slider arming time of

RESTRICTED

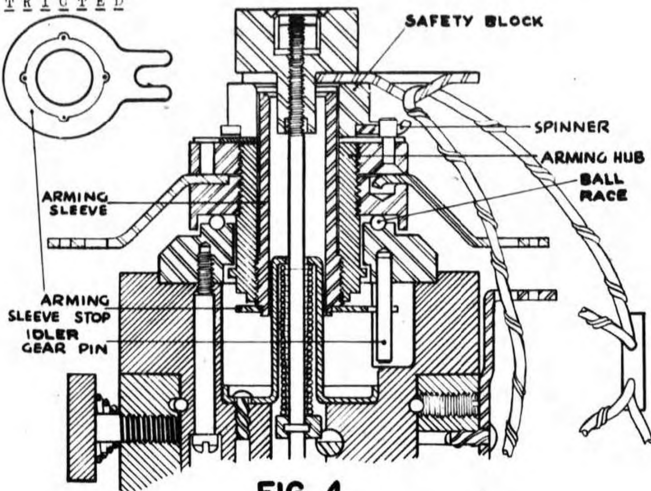

**FIG. 4**  
**BOMB NOSE FUZE M144**  
**(MECHANICAL TIME)**

1.5 ± .5 seconds (instead of 4.5 ± 1.5). Because of the shorter running time the clockwork is more accurate in the M144.

The M144 like the M128 incorporates a spinner device, to assure positive ejection of the safety block.

OPERATION

Upon release of the bomb, the arming wire is withdrawn from the fuze, the vanes are free to rotate and the arming pin jumps out. The vanes are positively attached to the arming hub and rotate as one unit. The arming sleeve, which is threaded to the arming hub and rotate as one unit. The arming sleeve stop plate attached to it, engages the idler gear pin. However, the arming sleeve moves down due to rotation of the arming hub, and after approximately 8 to 9 vane revolutions, the arming sleeve has withdrawn far enough for the safety collar to be thrown clear by centrifugal force.

The timing disc, meanwhile, has been rotated by the spring driven clockwork. After 1.5 ± .5 seconds of rotation, the timing disc cam, located below the timing disc (and turning with it), frees the crank-shaped end of the arming stem. Balance of operation same as the M128.

REMARKS

The M144 fuze was developed for use in 250-lb. and 1000-lb. target identification bombs now under development.

## BOMB TAIL FUZE M151

DESCRIPTION

The M151 fuze (formerly the T79E1, see AFEO Bulletin No. 11, page 4) shown in Fig. 5 consists of a M112A1 series fuze body which has been modified as follows:

The body has been lengthened to accommodate a plunger stem which is attached to the plunger proper. (Overall length of M151 body - 5155; overall length of M112A1 body 3176.)

A transverse arming stem replaces the regular in-line arming stem.

A retainer pin and spring type lock nut have been incorporated.

In addition, the M151 uses an anemometer type vane. The anemometer vane arming shaft is attached to the arming stem by a spring clip. For complete assembly see the above mentioned Bulletin.

OPERATION

Upon withdrawal of the arming wire from the arming shaft, the anemometer vane is free to rotate and causes the arming stem to unscrew from the fuze. After approximately 12 vane revolutions, the arming stem has withdrawn completely from the plunger stem and the fuze is armed. On impact, the plunger compresses the anti-creep spring and the spring loaded firing pin forces the locking balls out into the enlarged part of the fuze cavity, freeing the firing pin. The cocked firing pin spring forces the firing pin against the primer, initiating the delay in the primer detonator.

REMARKS

As mentioned in Bulletin No. 11, the M151 fuze is used in the 100, 250, and 500 pound anti-ricochet bombs. The 100 and 250 pound GP bombs are equipped with the M16 anti-ricochet device, while the 500 pound GP bombs are equipped with the M17 anti-ricochet device. The components of the anti-ricochet devices are as follows:

M16 Anti-Ricochet Device			M17 Anti-Ricochet Device		
Std Desig.	T Desig.	Item	Std Desig.	T Desig.	Item
M7	T4	Parachute	M6	T3	Parachute
M202	T3	Fuze adapter	M200	T1	Fuze adapter
M151	T79E1	Tail fuze	M151	T79E1	Tail fuze

RESTRICTED

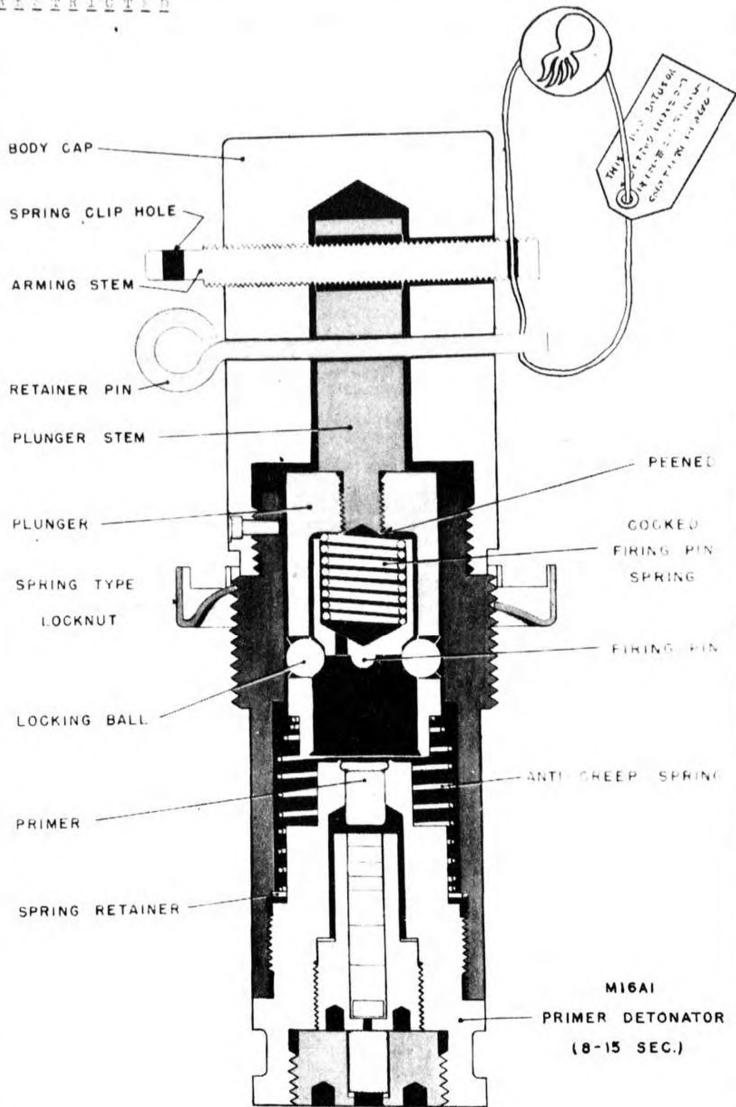

FIGURE 5  
FUZE BOMB TAIL M151 (T79 E1)

## BOMB TAIL FUZES M 152 & M 153

### INTRODUCTION

The Mechanical Time Tail Fuzes M152 and M153 are discussed jointly because of their similarity to one another. While each one is described briefly below, the essential difference between the two lies in the location and construction of the ball bearing assembly.

### DESCRIPTION

The M152 fuze (formerly the T53E1, see AFEO Bulletin No. 11, page 21) shown in Fig. 6, is similar to the M128 (T65) except for the following:

The M152 fuze has reversed vanes so that it will properly arm as a tail fuze.

The M152 fuze has a one-half tetryl booster, the balance of space in the booster cup being taken up by an inert clay pellet, while the M128 has a full tetryl booster.

In addition, a change was made in the construction of the ball bearing assembly for the arming vane assembly, to insure free rotation with the reversed thrust direction of a tail fuze as compared with a nose fuze.

The M153 fuze (formerly the T73, see AFEO Bulletin No. 11, page 21) is similar to the M128 (T65) except for the following:

The M153 fuze has reversed vanes so that it will properly arm as a tail fuze.

The M153 fuze has a one-half tetryl booster, the balance of space in the booster cup being taken up by an inert clay pellet, while the M128 has a full tetryl booster.

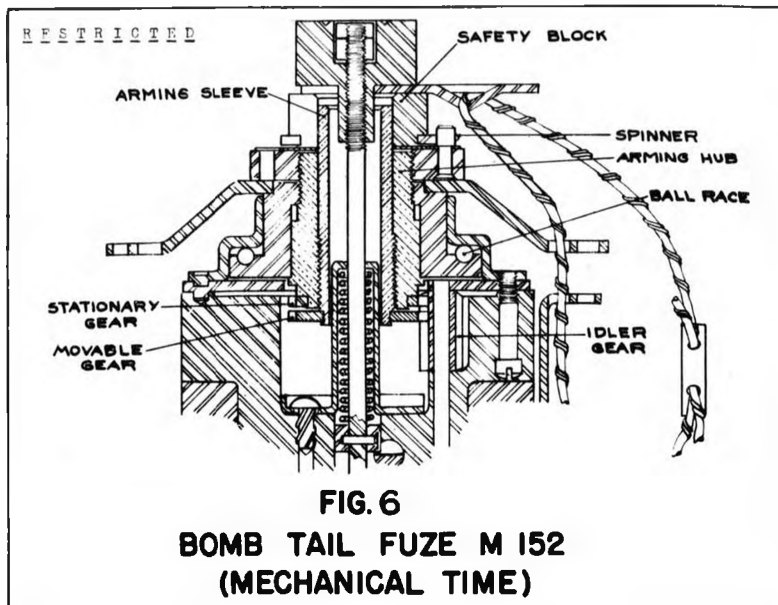

The vanes of the M152 and M153 are painted red to distinguish them from nose fuzes.

OPERATION

The operation of the M152 and M153 fuze is the same as the M128 fuze.

REMARKS

Personnel in the field can expect to see relatively few M153 fuzes simply because they were originally designed as a nose fuze and converted to a tail fuze by reversing the pitch of the vanes. This fuze acted as a temporary "carry over" requirement until production of M152 fuzes could be started. Hence, the M152, specifically designed as a tail fuze, is the better and preferred fuze.

Both the M152 and M153 fuzes were required for use as tail fuzes in aimable clusters of incendiary bombs. These clusters, just emerging from the development to service stage, have a tail assembly constructed to accommodate the mechanical time tail fuzes in conjunction with the M145 (T55E1) Mechanical Time Nose Fuze. (As further information becomes available on these clusters, it will be published in the AFEO Bulletin.)

- - - - -

R E S T R I C T E D

**BOMB NOSE FUZE M155**

DESCRIPTION

The M155 fuze (formerly the T71, see AFEO Bulletin No. 11, page 21) shown in Fig. 7, is the same as the M111A2 except for the following:

The M155 fuze eliminates the gear reduction system found in the M111A2. This is accomplished by removing the stationary gear from the arming hub, and pinning the idler gear in place so that it cannot rotate.

OPERATION

Upon releasing the cluster from the plane, the arming wire is withdrawn from the fuze, the vanes are free to rotate and the arming pin jumps out. The vanes are positively attached to the arming hub and rotate as one unit. The arming sleeve, which is threaded to the arming hub, is prevented from rotating since the movable gear which is attached to it, meshes with the pinned idler gear. However, the arming sleeve moves down due to rotation of the arming hub, and after approximately 6-9 vane revolutions the arming sleeve has withdrawn far enough for the safety block to be thrown clear by centrifugal force. The balance of the operation is the same as the M111A2.

REMARKS

The M155 fuze replaces the M11A2 in the M26 Cluster (20 AN-M41, 20-lb. frag. bombs) and the M27 Cluster (8 M82, 90-lb. frag. bombs). This replacement is being made since the above clusters fused with the M11A2 sometimes failed to open with low fuze settings, as the cluster flight is not always stable enough to permit arming of the M11A2 fuze before the set time expires. Elimination of the gear reduction system obviates this difficulty. The spinner device insures ejection of the safety block at completion of arming.

-----

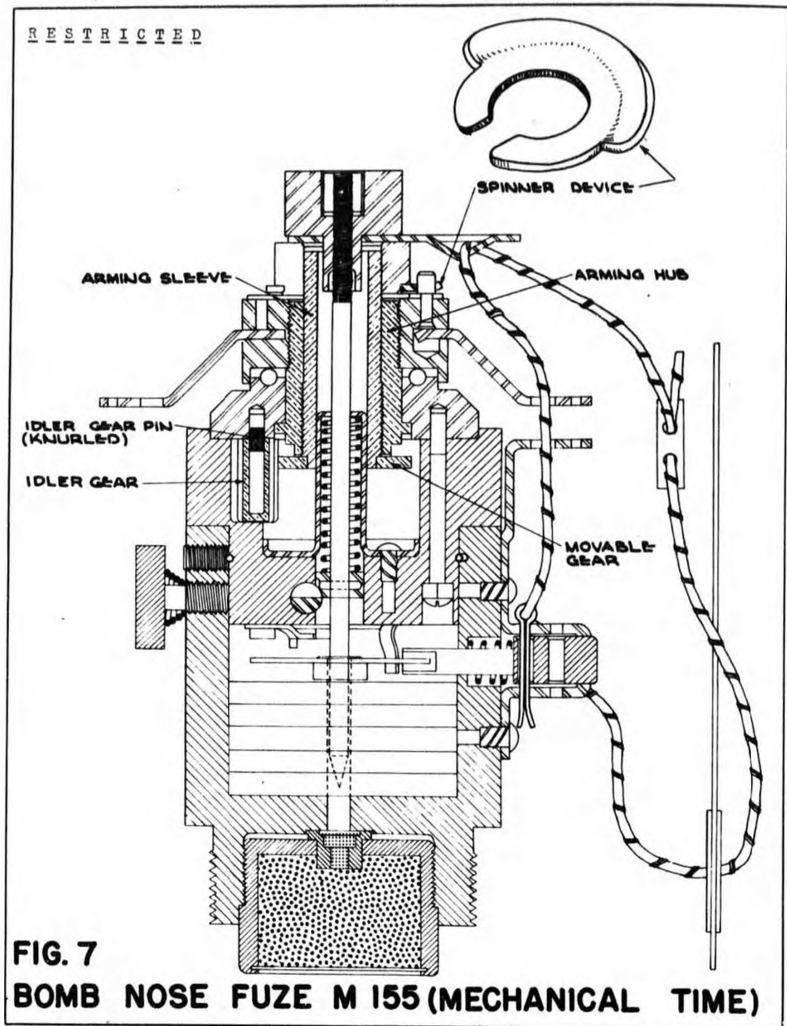

# MISCELLANEOUS

C O N F I D E N T I A L

## STATUS & AVAILABILITY OF AIRCRAFT BOMBS, BOMB FUZES & ACCESSORIES

With the influx of many new ordnance items in the past year, ordnance personnel in the field have been confronted with the problem of trying to keep up-to-date on the old as well as the new developments. The following charts, listing current status and availability of bombs, fuzes and related miscellaneous ordnance items, have been prepared in an effort to provide a handy reference with a brief description and remarks on existing items. Most of the data have been compiled from Navord OCL AV30-44, and Navord OCL AV3-45.

### STATUS AND AVAILABILITY OF AIRCRAFT BOMB FUZES - NAVY DESIGN

DESIGNATION	DESCRIPTION	USE, STATUS AND REMARKS
AN-Mk 219 & Mods	Nose, instantaneous, impact.	Navy 100-lb. GP; 100 Chem.; 30 lb. Frag. (No aux. booster). With adapter ring and extra Auxiliary Booster, Mk 1, in all other Navy GP bombs and all Depth Bombs. With adapter ring and one Auxiliary Booster, Mk 4, in all Army bombs 100-lbs. or over except 100-lb. Chemical and Incendiary. Service. In stock. Mk 219 Mod 1 Lots 1-70 incl., AN-Mk 219 Mod 2 Lots 71-117, restricted to target use only. See OCL AV3-45. For use of "ANTI-PERSONNEL" attachment see OTI AV9-43 and OCL AV74-43.
Mk 221 & Mods	Nose, short delay (.01 sec), Impact.	500 & 1000-lb. Navy GP bombs and all Depth bombs. Obsolescent. In stock. Mk 221 Mod 0, all lots restricted to target use only. See OCL AV3-45.
Mk 223 & Mods	Tail, short delay (.01 sec), Impact.	500 & 1000-lb. Navy GP bombs. Obsolescent. In stock. Mk 223 Mod 0, all lots restricted to target use only, see OCL AV3-45. Mk 223 (AS) Lots 38, 40, 45 and 46 unsuitable and are to be turned into nearest NAD by continental activities for reworking. (To be reworked into Mk 223). Ex-Cont. act.-replaced items to be disposed of in deep water. See OCL AV3-45.
AN-Mk 224 & Mods	Athwartship, hydrostatic. (25', 50', 75', 100', 125' selective depth setting, by dis-assembly.)	All Depth bombs except the Mk 53 & Mk 54 type. (Requires the use of a Spacer when employed in 650-lb. and 700-lb. bombs). Obsolescent. In stock. Mk 224 Mod 0, all lots, and AN-Mk 224 Mod 1, all lots of series A, B, C, unsuitable and are to be turned in to nearest NAD by continental activities for reworking. (To have explos. elements replaced). Ex-cont. act.-replaced items to be disposed of in deep water. AN-Mk 224 Mod 2 (Stewart Warner) lots 27, 29, 30, 31, 32, 34, 35, 37, 39, 40, 41, 42, 43,

STATUS AND AVAILABILITY OF AIRCRAFT BOMB FUZES - NAVY DESIGN (cont)

DESIGNATION	DESCRIPTION	USE, STATUS AND REMARKS
AN-Mk 224 & Voda (cont)		47-101 incl. and 107 unsuitable and to be turned into nearest NAD by continental act. for reworking. (To have plastic baffles replaced with bronze baffles). Ex-cont. act.-replaced items to be disposed of in deep water. (See OCL AV3-45 covering above). Being replaced by the AN-Mk 234. (Use of AN-Mk 224 or AN-Mk 234 not recommended, since not air arming type; AN-Mk 230 Mod 4 or AN-Mk 229 Mod 3 are preferred fuzes, per OCL AV3-45.
Mk 227 Mod 0	Nose, instantaneous, impact.	All Anti-Aircraft bombs. Service. In stock.
AN-Mk 228 & Mods	Tail, short delay (.08 sec), impact.	All Navy design Armor Piercing bombs. Service. In stock.
Mk 229 Mod 1, 2	Tail, hydrostatic. (25', 50', 75', 100', & 125', selective depth setting.)	All 650-lb. & 700-lb. Depth bombs and Navy 500-lb. and 1000-lb. GP bombs. Mk 229 Mod 1, 2; Obsolescent. In stock. Being replaced by the Mk 229 Mod 3. Mk 229 Mod 3; Service. In stock. Incorporates safety features. Use "O" ring gasket and special Spacer Ring with both.*
Mk 229 Mod 3		
AN-Mk 230 Mod 1, 3	Tail, hydrostatic. (25', 50', 75', 100', & 125', selective depth setting.)	Mk 53 and Mk 54 type Depth bombs, AN-GP 60 series by removal of the adapter (inner sleeve) from the M115 adapter booster.
AN-Mk 230 Mod 4		AN-Mk 230 Mod 1, 3; Obsolescent. In stock. Being replaced by AN-Mk 230 Mod 4, 5. AN-Mk 230 Mod 4; Service. In stock. Incorporates ANTI-CRASH features. AN-Mk 230 Mod 5; is an AN-Mk 230 Mod 4 converted from a Mk 229. Use "O" ring gasket and special Spacer Ring with all three.*
AN-Mk 230 Mod 5		
Mk 231 Mod 0	Tail, hydrostatic, (25' single depth setting.)	Mk 53 and Mk 54 type depth bombs, AN-GP 60 series by removal of the adapter (inner sleeve) from the M115 adapter booster. Under development. No availability date set.
Mk 232 Mod 1	Nose, Impact or electrical firing.	Special fuze; not for general issue. Limited availability. Procured through NMD Yorktown and NAD Hawthorne.
Mk 233 Mod 0	Nose, electrical firing.	Special fuze; not for general issue. Limited availability. Procured through NMD Yorktown and NAD Hawthorne.
AN-Mk 234 & Mods	Aftership hydrostatic (25', 50', 75', 100', 125' selective depth setting)	All Depth bombs except the Mk 53 and Mk 54 type. (Requires the use of a Spacer when employed in the 650-lb. and 700-lb. Depth bombs.) Service. In stock. AN-Mk 234 Mod 2 (Stewart Warner). Lots 1-141 incl to be turned in to the nearest NAD by Cont. act. for reworking. (To have plastic baffles replaced with bronze baffles). Ex-Cont. act.-replaced item to be disposed of in deep water.
<p>* Spacer Ring should be used with "O" Ring Gasket with all tail, hydrostatic fuzes except those incorporating "C" Ring Gasket Undercut" in fuze construction. Fuzes incorporating "undercut" are:                      (a) Reco Motors AN-Mk 230 lots 72, 75, and all lots thereafter.                      (b) Aldon Products AN-Mk 230 beginning with carton No. 4999 of lot 26 and all lots thereafter.</p>		

C O N F I D E N T I A L

STATUS AND AVAILABILITY OF AIRCRAFT BOMB FUZES - NAVY DESIGN (cont)

DESIGNATION	DESCRIPTION	USE, STATUS AND REMARKS
AN-Mk 234 & Mods (cont)		(Use of AN-Mk 234 not recommended, since not air arming type; AN-Mk 230 Mod 4 or AN-Mk 229 Mod 3 tail fuzes preferred, per OCL AV3-46.)
Mk 235 Mod 0 Mk 236 Mod 0	Nose Tail	Special fuze; not for general issue. Limited availability.
Mk 237 Mod 0 Mk 238 Mod 0	Tail, Long delay time (2, 10, and 30 hours).	Mk 237 Mod 0: AN-M64 and AN-M64A1 500-lb. GP bomb. Limited availability in early 1945. Mk 238 Mod 0: AN-M65 AN-M65A1, AN-M66, and AN-M66A1 1000-lb. and 2000-lb. GP bombs. All series preferred. Limited availability in early 1945.
Mk 239 Mod 0	Nose, short delay (.01 sec), Impact.	All AN-M GP bombs, Depth bombs, or Navy GP bombs except the 100-lb. Navy GP bomb. Limited availability in early 1945. This fuze is the Mk 221 with reduced diameter in booster end.
Mk 243 Mod 0	Nose, short delay (.025 sec), impact, with discriminating feature. Will function on 1/4" plate, but not on water.	All AN-M GP bombs, or Navy GP bombs except the 100-lb. size. Available in quantity. Service.

STATUS AND AVAILABILITY OF AIRCRAFT BOMB FUZES - ARMY DESIGN

DESIGNATION	T DESIG.	DESCRIPTION	USE, STATUS AND REMARKS
AN-M100A1 AN-M101A1 AN-M102A1		Tail, Short Delay Impact, (M14 Primer Detonator)	AN-M100A1: 100-lb. & 250-lb. GP's, 220-lb. and 260-lb. Frag. bombs. AN-M101A1: 500-lb. GP, SAP, Chem., and Incendiary bombs. AN-M102A1: 1000-lb. & 2000-lb. GP, 1000-lb. SAP, and 500-lb. & 1000-lb. Navy GP bombs with M102 adapter booster and spacer ring (OCL V8-43). All stocks being returned to the Army. If used should be prepared per OCL V38-42.
AN-M100A2 AN-M101A2 AN-M102A2		Tail, Short Delay Impact, (M14 Primer Detonator)	AN-M100A2: 100-lb. & 250-lb. GP's, 220-lb. and 260-lb. Frag. bombs. AN-M101A2: 500-lb. GP, SAP, Chem., and Incendiary bombs. AN-M102A2: 1000-lb. & 2000-lb. GP, 1000-lb. SAP, and 500-lb. & 1000-lb. Navy GP bombs with M102 adapter-booster and spacer ring (OCL V8-43). Service. In stock.
M103		Nose, instantaneous or .10 second delay, impact. (Long arming time).	All bombs weighing 100-lb. or over receiving a nose fuze, except Navy 100-lb. Mk 4 and Mods, AN-M47A2, and M70 bombs. Obsolescent Army item. Never procured by Navy; however, may be encountered. Replaced by AN-M103. M103. Lots P.A. 2717-1 to 6 incl. P.A. 5189-1 to 2 incl., P.A. 6284-1 to 2 incl., P.A. 3-6285-1 to 22 incl., P.A. 1-6286-1 to 24 incl., P.A. 7348-1, P.A. 8135-1 to 5 incl., P.A. 8-1534-1

STATUS AND AVAILABILITY OF AIRCRAFT BOMB FUZES - Army DESIGN (cont)

DESIGNATION	T DESIG.	DESCRIPTION	USE, STATUS AND REMARKS
M103 (cont)			to 29 incl., P.A. 24-22205-1 to 10 incl., P.O.P. 2-23202-1, A.O.P. 2-23202-7 to 13 incl., A.O.P. 2-23202-40 to 41 incl., E.O.P. 7-23204-1 to 2 incl., R.O.P. 4-23214-22, R.O.P. 4-23214-1 to 3 incl., A.O.P. 2-23202-68, are unsuitable and are to be turned in to nearest NAD by continental activities for reworking (reloading and resealing explosive train). Ex-cont. act.-replaced items to be disposed of in deep water. (See OCL AV3-45.)
AN-M103		Nose, instantaneous or .10 second delay, impact.	90-lb. frag. bomb and all bombs weighing 100-lb. or over receiving a nose fuze, except Navy 100-lb. Mk 4 and Mods, AN-M47A2, and M70 bombs. In Stock. To be replaced by the AN-M103AL. AN-M103 not recommended for use from carriers, fuze AN-Mk 219 should be substituted if available pending receipt of AN-M103AL, per OCL AV AN-M103, lots A.O.P. 2-23202-56 to 67 incl., A.O.P. 2-23202-69 to 99 incl., PA 23-22205-1 to 21 incl., A.O.P. 11-100 to 109 incl., A.O.P. 110 to 226 incl., PA 9-15534-1 to 14 incl., A.O.P. 2-23202-3 to 6 incl., A.O.P. 2-23202-14 to 39 incl., A.O.P. 2-23202-42 to 55 incl., E.O.P. 2-23204-1 to 30 incl., I.O.P. 17-23207-1 to 5 incl., R.O.P. 4-23214-4 to 10 incl., P.A. 52882-1, are unsuitable and are to be turned in to nearest NAD by continental activities for reworking (reloading and resealing explosive train). Ex. cont. act.-replaced items to be disposed of in deep water. (See OCL AV3-45J)
AN-M103AL		Nose, instantaneous or .10 second delay, impact.	90-lb frag. bomb and all bombs weighing 100-lb. or over receiving a nose fuze, except Navy 100-lb. Mk 4 & Mods, AN-M47A2, and M70 bombs. Available. Incorporates Anti-crash features.
AN-M104		Nose, Instantaneous, Impact. Has Pyrotechnic delay arming.	Clustered parachute fragmentation bombs, AN-M40 or AN-M40AL. Classed Obsolete by the Army. Replaced by AN-M120AL. Not for carrier use.
M105		Nose, Instantaneous or .10 sec. Impact	Modified Mark Series bombs. Obsolete. Never procured by Navy.
M106		Tail, Long delay Impact	GP Bombs. Obsolete. Restricted from Naval use, see OCL AV3-45.
M107		Nose, Aerial Burst Mechanical Time	Obsolete 20-lb. Practice Frag. bombs. Obsolete. Never procured by the Navy. See OCL AV3-45.
M108		Nose, Instantaneous, Impact, Inst. arming	Limited Std. for M75 - 100-lb. practice bomb (Army). Light Case Chemical bombs. Replaced by AN-M126AL. Declared obsolete by Navy, see OCL AV3-45.
M109		Nose, Instantaneous, Impact. (Small head)	Fragmentation bombs. Obsolete. Never procured by the Navy.

CONFIDENTIAL

STATUS AND AVAILABILITY OF AIRCRAFT BOMB FUZES - ARMY DESIGN (cont)

DESIGNATION	T DESIG.	DESCRIPTION	USE, STATUS AND REMARKS
M110		Nose, Instantaneous, Impact.	Clustered fragmentation bombs, AN-M41, and Chemical bomb, M70. Obsolete, See OCL A24-43 and A24-45. Replaced by the AN-M110A1.
AN-M110A1		Nose, Instantaneous, Impact.	Clustered fragmentation bombs, AN-M41 and Chemical bomb, M70. Service, Available, See OCL A24-43 and A24-45. (Bombs with this fuze or the M110 should be jettisoned before returning to a carrier, since not carrier safe. See OCL AV3-45.)
M111		Nose, Mechanical Time Aerial Burst, or Impact. (15-93 sec.)	Parachute Flares, Photoflash bombs and some Aimable Clusters. Obsolete, limited availability. Replaced by the M111A2.
M111A1		Nose, Mechanical Time, Aerial Burst, or Impact. (5-92 Sec.)	Parachute Flares, Photoflash bombs and some Aimable Clusters. Obsolete, Available, Replaced by the M111A2.
M111A2		Nose, Mechanical Time, Aerial Burst, or Impact. (5-92 sec.)	Parachute Flares, Photoflash bombs and some Aimable Clusters. Service, Available.
M112		Tail (4-5, 8-11 sec) Delay	M112: 100-lb. & 250-lb. GP bombs.
M113		Impact, (M16 Primer Detonator)	M113: 500-lb. GP and SAP bombs.
M114			M114: 1000-lb. & 2000-lb. GP and 1000-lb. SAP, and 500-lb. & 1000-lb. Navy GP bombs with M102 adapter-booster and spacer ring (OCL V8-43). For Minimum Altitude Bombing. In Stock, but being replaced by the A1 series. Not safe for carrier use. per OCL AV3-45. (Past arming). M116-16-17 fuzes preferred.
M112A1		Tail, (4-5, 8-11, 8-15 sec) delay. Impact, (M16 or M16A1 Primer Detonator)	M112A1: 100-lb. & 250-lb. GP bombs.
M113A1			M113A1: 500-lb. GP and SAP bombs.
M114A1			M114A1: 1000-lb. & 2000-lb. GP, 1000-lb. SAP, and 500-lb. & 1000-lb. Navy GP bombs. See OCL V8-43. For Minimum Altitude Bombing. In stock. NOT safe for carrier use (Past arming). Lots PA-117-24 and PA-117-27 suspended from issue, per OCL AV3-45. M115-16-17 fuzes preferred.
M115		Tail, (4-5, 8-11, 8-15 sec) delay Impact, (M16 or M16A1 Primer Detonator)	M115: 100-lb. & 250-lb. GP bombs.
M116			M116: 500-lb. GP and SAP bombs.
M117			M117: 1000-lb. & 2000-lb. GP, 1000-lb. SAP, and 500-lb. & 1000-lb. Navy GP bombs. See OCL V8-43. For Minimum Altitude Bombing. In stock. Safe for carrier use, has gear reduction system.
(M118) (M119)		Nose, 4-5 sec del. Imp. " 8-11 " " "	Any GP bombs except Navy Mk 4 and Mods. Not successful, destandardized to T32 and T33.
AN-M120		Nose, Instantaneous, Impact, 2.5 sec. arming	Clustered parachute fragmentation bombs, AN-M40 and AN-M40A1. Not safe for CV use, per OCL AV3-45. Not available in Navy clusters.

STATUS AND AVAILABILITY OF AIRCRAFT BOMB FUZES - ARMY DESIGN (cont)

<u>DESIGNATION</u>	<u>T</u> <u>DESIG.</u>	<u>DESCRIPTION</u>	<u>USE, STATUS AND REMARKS</u>
AN-M120A1		Nose, Instantaneous, Impact, 1.9 sec. arming	Clustered parachute fragmentation bombs AN-M40 and AN-M40A1. Service, Available, not safe for carrier use. (per OCL AV3-45.)
M121 M122		Special Tail Fuse Special Tail Fuse	Special. Never procured by the Navy. Special. Never procured by the Navy.
M123 M124 M125	T38 T38 T38	Tail, long delay, Impact. Available delays are 1 hr, 2 hrs, 6 hrs, 12 hrs, 24 hrs, 36 hrs, 72 hrs, and 144 hrs. These fuses have an anti-withdrawal device.	M123: 100-lb. & 250-lb. GP bombs. M124: 500-lb. GP and SAP bombs. M125: 1000-lb. & 2000-lb. GP, and 1000-lb. SAP bombs. The A1 and A2 series of the above bombs are preferred. Note: Use only those fuses whose lower fuse body is pinned to the upper fuse body to avoid aerial burst. In stock. Must be jettisoned before landing. Lots as follows restricted due to faulty ampoules and unpinned lower fuse bodies: M123, PAR 82, 83, 85-87, 101, 106, 109, 115, 118-120, & 129; M124, PAR 27, 28, 30, 40, 41, 44-46, 52, 54, 58, 62, 60, 96, 99, 103, 107, 112, 121 & 123; M125, PAR 49-51, 63, 70, 72, 79, 81, 100, 106, 111 and 124-126. Above lots to be turned in to nearest NAD by continental activities for reworking. Ex-cont. act: -replaced items to be disposed of in deep water. See OCL AV3-45.
M125A1 M124A1 M126A1		Tail, long delay Impact, Delays available are 1 hr to 144 hrs. Direct drive, no gear reduction. Have anti-withdrawal device.	GP and SAP bombs as above. The A1 and A2 series bombs with staked parts are preferred. Must be jettisoned before landing. (OCL AV3-45.) Available in February in limited quantity.
AN-M126		Nose, Inst.Imp. (M110 W/O booster and W/det. holder).	Chemical bombs 100-lb. AN-M47A2. Obsolescent, replaced by AN-M126A1.
AN-M126A1		Nose, Instantaneous, Impact. (AN-M110A1 W/detonator holder)	Chemical bombs 100-lb. AN-M47A2. Service. In stock. Bombs with this fuse should be jettisoned before returning to a carrier, since not det. safe, per OCL AV3-45.
M127	T39	Nose, Mechanical Time, Air Burst. (The M111A2 W/ the M110 tetryl booster) Setting range 5-92 sec.	Aimable Clusters, and 500-lb. and 1000-lb. Chemical bombs with M117 adapter booster. (Replaced by M128). Not procured for Naval use. Not detonator safe.
M128	T55	Nose, Mechanical Time, Air Burst. (M111A2 W/ tetryl booster and detonator slider) Setting range 5-92 sec.	Aimable Clusters, and 500-lb. & 1000-lb. Chemical bombs with M117 adapter-booster. Available. This fuse is detonator safe. (Replaces M127)
M129 (M130) (M131)	T47 T48E1 T49	Amdships. M129: Impact or aerial burst. M130: 10, 20, or 30 minute delay. M131: Anti-disturbance.	Fragmentation (Butterfly) bombs M83. (Shipped installed) Available with bombs M83. M130 and M131: are now T48E1 and T49, not yet standardized by the Army.
M132 M133 M134	T41 T41 T41	Tail, Chemical Time Delay (10 minute nominal delay)	M132: 100-lb. and 250-lb. GP bombs. M133: 500-lb. GP and SAP bombs. M134: 1000-lb. GP and SAP, and 2000-lb. GP bombs. Available in the Army. Limited availability in the Navy.

CONFIDENTIAL

STATUS AND AVAILABILITY OF AIRCRAFT BOMB FUZES - ARMY DESIGN (cont)

DESIGNATION	T DESIG.	DESCRIPTION	USE, STATUS AND REMARKS
M135	T66	Nose, Mechanical Time, Air Burst (M11A2 in the body of an AN-M103) Setting range 5-92 sec.	Can be used anywhere the AN-M103 fuse is used. Not procured for Naval use. Not suitable for Naval use.
M135A1		Same as M135 except minimum setting of 10 sec.	Will replace M135. Available summer of 1945 for Army use.
M136	T66E1	Same as M135 except setting range 5-30.6 sec.	Same as M135 above. Not procured for Naval use. Not suitable for Naval use.
M136A1		Same as M136 except minimum setting of 10 sec.	Will replace M136. Available summer of 1946 for Army use.
M137	T61	Special	Special
M138	T39E1	M127 with 1/2 tetryl booster. (Setting range 5-92 sec)	Aimable Incendiary Clusters. Not procured by Navy.
M139 M140	T66 T67	Nose, Impact. M139 is the AN-M103 w/ .01 sec delay, M140 w/ .025 sec.	Can be used anywhere the AN-M103 fuse is used. Not procured by Navy. Replaced by M139A1 and M140A1.
M139A1 M140A1		Nose, Impact, M139A1 is the AN-M103A1 w/ .01 sec. delay, M140A1 w/ .025 sec.	Can be used anywhere the AN-M103A1 fuse is used. Not procured at present by Navy. Replaces M139 and M140
(M141)			This number not assigned at present; however, is reserved for GWS usage.
M142		Nose, All-ways action Impact fuze.	M74 Incendiary Bomb (IM or NP) 10-lb. Supersedes M5; used in present production of M74.
M143		Tail, consists of 4 bouchon grenade type fuzes mounted on a support.	M87 Smoke Bomb (Colored Streamer).
M144	T64	Nose, Mechanical Time, Aerial Burst. Same as M146 except 1.6 - 30.6 sec. range and no gear reduction.	Will be used for low altitude drops in 250-lb. and 1000-lb. target identification bombs under development.
M145	T55E1	Nose, Mechanical Time, Air Burst. (M128 with 1/2 tetryl booster) Setting range 5-92 sec.	Aimable incendiary clusters. Replaces M138.
M146	T55E2	Nose, Mechanical Time, Air Burst. (M128 with black powder booster) Setting range 5-92 sec.	Flares, Photoflash Bombs, M28 and M29 Butterfly Bomb Clusters. Replaces M11A2. Also, for high alt. drops of tar. ident. bombs under development.
M147	T55E3	Nose, Mechanical Time, Air Burst. (M128 with AN-M126A1 Det holder). Setting range 5-92 sec.	M84 100-lb. Target Identification Bomb.
M148	T64	Nose, Same as AN-M103 except modified booster cup and special reduced diameter threads.	Jap Navy Bombs. Available. (Limited quan.)

## STATUS AND AVAILABILITY OF AIRCRAFT BOMB FUSES - ARMY DESIGN (cont)

DESIGNATION	T DESIG.	DESCRIPTION	USE, STATUS AND REMARKS
M149	T29E2	Nose, Pressure Blast or Impact.	Any GP bomb that accommodates the AN-M103. Available, Army procuring, Navy not as yet.
M150		Tail, All-ways Action Impact Fuse.	M77 10-lb. Smoke (HC) Bomb. Formerly Designated M4.
M151	T79E1	Tail, similar to M112A1 series with transverse arming stem and anemometer vane.	Anti-ricochet bombs. 100 and 250-lb. GP bombs equipped with M7 parachute and M202 fuze adapter, or 500-lb. GP bombs equipped with M5 parachute and M200 fuze adapter.
M152	T53E1	Tail, Mechanical Time, Air Burst. Same as M145 except modified thrust bearing and reversed vane. Setting range 5-92 sec.	Aimable incendiary clusters. Will replace M153. Available spring 1945.
M153	T73	Tail, Mechanical Time, Air Burst. Same as M145 except reversed vane. Setting range 5-92 sec.	Aimable incendiary clusters. Being replaced by M152. Available.
M154	E9R17	All-ways action fuze.	M13 Igniter (Tail position type) M14 Igniter (Tank cap type) (For aircraft jettisonable gas tanks).
M155	T71	Nose, Mechanical Time, Air Burst. Same as M111A2 except no gear reduction. Setting range 5-92 sec.	M26 cluster - 20 - 20-lb. Frag. bombs AN-M41. M27 cluster - 6 - 90-lb. Frag. bombs M22. Available.
M156		Special Fuze	Special Use
M157	E9R22	Anemometer type, all-ways action fuze.	M15 igniter (Tail position type) M16 igniter (Tank cap type) (For aircraft jettisonable gas tanks).

## STATUS AND AVAILABILITY OF AIRCRAFT BOMBS - NAVY AND ARMY DESIGNS

DESIGNATION	STATUS AND REMARKS
2-lb. AA, Mk 32 Mod 0 (2" Type C)	Being declared obsolete. Superseded by Mk 34.
2-lb. AA, Mk 32 Mod 0 (3" Type D)	Being declared obsolete. Superseded by Mk 34.
3-lb. Min. Practice Mk 3 and Mods	Being declared obsolete. Superseded by AN-Mk 23 and AN-Mk 43.
3-lb. Min. Practice Mk 4 Mod 0	Being declared obsolete. Superseded by AN-Mk 23 and AN-Mk 43.
3-lb. Min. Practice Mk 5 Mod 0	Being declared obsolete. Superseded by AN-Mk 23 and AN-Mk 43.

C O N F I D E N T I A L

STATUS AND AVAILABILITY OF AIRCRAFT BOMBS - NAVY AND ARMY DESIGNS(cont)

<u>DESIGNATION</u>	<u>STATUS AND REMARKS</u>
3-lb. Min. Practice AN-Mk 5 Mod 1	Service, limited availability. Superseded by AN-Mk 23 and AN-Mk 43.
3-lb. Min. Practice AN-Mk 23	Service, available.
3-lb. Min. Practice AN-Mk 23 Mod 1	Service, available Incorporates Tail Shroud.
4½-lb. Min. Practice AN-Mk 43	Service, available.
4½-lb. Min. Practice AN-Mk 43 Mod 1	Service, available. Incorporates Tail Shroud.
5-lb. AA Mk 34 Mod 1	Service, available at NAD Crane, Hawthorne and Oahu
15-lb. Min. Practice Mk 19 & Mods	Service, available.
30-lb. Practice Mk 3 Mod 0	Being declared obsolete.
30-lb. Frag. Mk 5 & Mods	Being declared obsolete. Superseded by fragmentation clusters.
50-lb. Smoke (Floating) Mk 1 Mod 0	Being declared obsolete. Superseded by Mk 1 Mod 1. Expend in Target Prac.
50-lb. Smoke (Floating) Mk 1 Mod 1	Service, available. To be superseded by Mk 1 Mod 2
50-lb. Smoke (Floating) Mk 1 Mod 2	Service, available. Longer burning time than Mk 1 Mod 1
90-lb. Fragmentation M82 (T9)	Used in M27 (T8) Cluster; also individually
100-lb. Incendiary Mk 1 Mod 0	Being declared obsolete. Superseded by AN-M47A2. Expend as WF prac. bomb.
100-lb. Incendiary Mk 28 Mod 0	Being declared obsolete. Superseded by AN-M47A2. Expend as WF prac. bomb
100-lb. Incendiary M47	Being declared obsolete. Superseded by AN-M47A2. Expend as WF prac. bomb.
100-lb. Incendiary M47A1	Being declared obsolete. Superseded by AN-M47A2. Expend as WF prac. bomb.
100-lb. Smoke M47A2	Service, available. WP filled.
100-lb. Incendiary AN-M47A2	Service, available. NP or IM filled.
100-lb. Incendiary AN-M47A3	Available spring 1945. Will replace AN-M47A2. Same as AN-M47A2 except tail 3" longer. IM or NP filled.
100-lb. Smoke (Floating) Mk 3 Mod 0	Service, Available. HC Smoke Mixture filled.
100-lb. Chemical Mk 42 Mod 0	Being declared obsolete. Superseded by the M70. Available NAD Hawthorne.

C O N F I D E N T I A L

STATUS AND AVAILABILITY OF AIRCRAFT BOMBS - NAVY AND ARMY DESIGNS (cont)

<u>DESIGNATION</u>	<u>STATUS AND REMARKS</u>
100-lb. Demolition LTA Mk 52 Mod 0	Being declared obsolete. Limited availability at NMD Yorktown
100-lb. Demolition Mk 1 & Mods	Being declared obsolete. Limited availability for practice.
100-lb. GP Mk 4 and Mods	Being declared obsolete. Limited availability for practice.
100-lb. GP AN-M50	Service, Available. Being superseded by the AN-M50A1.
100-lb. GP AN-M50A1	Service, available. See OCL AV130-45.
100-lb. WF Practice Mk 7 Mod 0	Limited availability, superseded by the Mk 15 Mod 2
100-lb. WF Practice Mk 15 Mod 0	None available, superseded by the Mk 15 Mod 2
100-lb. WF Practice Mk 15 Mod 2	Service, available.
100-lb. Colored Streamer M87 (Smoke)	Limited availability; Special Army use.
110-lb. Parachute Frag. M86 (T13)	Formerly T13; can be clustered with M12 Cluster Adapter
115-lb. Chemical M70	Service, available in quantity at NAD Hawthorne.
150-lb. GP T-1 (A modified M70 bomb)	Service, available. (Army) Navy not procuring. TNT loaded.
220-lb. Fragmentation M88	To be produced in spring of 1945 as replacement for 260-lb. AN-M81.
250-lb. GP AN-M57	Service, available. Being superseded by the AN-M57A1.
250-lb. GP AN-M57A1	Service, limited availability at present. See OCL AV130-45.
260-lb. Fragmentation AN-M81	Service, available.
325-lb. Depth Mk 17 Mod 0	Obsolete. None Available for issue, (Restricted to target use, OCL AV3-45.)
325-lb. Depth Mk 17 Mod 1	Being declared obsolete, expend in target practice.
325-lb. Depth Mk 17 Mod 2	Service, Available. May be expended in target practice.
325-lb. Depth AN-Mk 17 Mod 2	Service, available. May be expended in target practice.
325-lb. Depth AN-Mk 41 (Flat nose)	Service, limited availability. May be expended in practice.
325-lb. Depth Mk 53 (Flat nose)	Service, not available. None loaded. (Has screw-on type suspension lugs)
325-lb. Depth AN-Mk 53 Mod 1 (Flat nose)	Service, not available. None loaded. (Has welded-on suspension lugs)
350-lb. Depth AN-Mk 44	Service, limited availability NMD/y May be expended in target practice.

CONFIDENTIAL

STATUS AND AVAILABILITY OF AIRCRAFT BOMBS - NAVY AND ARMY DESIGNS (cont)

<u>DESIGNATION</u>	<u>STATUS AND REMARKS</u>
350-lb. Depth AN-Mk 47 (Flat nose)	Service, available.
350-lb. Depth Mk 54 (Flat nose)	Service, available. (Has screw on type suspension lugs.)
350-lb. Depth AN-Mk 54 Mod 1 (Flat nose)	Service, available March 1945. (Has welded on suspension lugs.)
650-lb. Depth Mk 29	Non-existent. Converted to the Mk 37 by replacing tail, per OCL AV41-43. Tail declared obsolete, per OCL AV3-45.
650-lb. Depth Mk 37	ASW low altitude use restricted. If these bombs used for operations or training, min. safe alt. of rel. per CominCh must be observed. (See AFEO No. 7, p. 16). Available. May be expended for practice. (OCL AV3-45.)
650-lb. Depth Mk 38 (Flat nose)	ASW low altitude use restricted. If these bombs used for operations or training, min. safe alt. of rel. per CominCh must be observed. (See AFEO No. 7, p. 16). Available. May be expended for practice. (OCL AV3-45.)
700-lb. Depth Mk 49 (Flat nose)	ASW low altitude use restricted. If these bombs used for operations or training, min. safe alt. of rel. per CominCh must be observed. (See AFEO No. 7, p. 16). Limited availability. May be expended for practice. (OCL AV3 45)
500-lb. Dem. Mk 3 and Mods	Being declared obsolete. None available.
500-lb. Dem. Mk 5 and Mods	Being declared obsolete. None available.
500-lb. Dem. Mk 9	Being declared obsolete. Limited availability. Expend in practice.
500-lb. GP Mk 12 and Mk 12 Mod 1	Being declared obsolete. Limited availability. Expend in practice.
500-lb. GP Mk 12 Mod 2	Service. Limited availability. May be expended in target practice.
500-lb. GP AN-M43	Service. Limited availability. Being replaced by the AN-M64A1.
500-lb. GP AN-M64	Service. Available. Will be replaced by the AN-M64A1.
500-lb. GP AN-M64A1	Service. Available. (See OCL AV130-43)
500-lb. SAP AN-M58	Service. Limited availability. Will be replaced by the AN-M58A2.
500-lb. SAP AN-M58A1	Service. Available. Will be replaced by the AN-M58A2.
500-lb. SAP AN-M58A2	Service. Not available at present. (See OCL AV-130-43)
500-lb. Inc. AN-M76	Service. Limited availability NAD Hawthorne.

C O N F I D E N T I A L

STATUS AND AVAILABILITY OF AIRCRAFT BOMBS - NAVY AND ARMY DESIGN (cont)

<u>DESIGNATION</u>	<u>STATUS AND REMARKS</u>
500-lb. Chem. AN-M78	Service. Available NAD Hawthorne. Not procured for general use.
500-lb. Prac. (WF) Mk 5	None available. Superseded by the Mk 21
500-lb. Prac. (WF) Mk 11	Limited availability. Superseded by the Mk 21
500-lb. Prac. (WF) Mk 21 Mod 0	Service. Available limited. Increasing production in February 1945.
1000-lb. Dem. Mk 3 and Mods	Being declared obsolete. Limited availability. Expend for practice.
1000-lb. Dem. Mk 5 and Mods	Being declared obsolete. Limited availability. Expend for practice.
1000-lb. Dem. Mk 9	Being declared obsolete. Limited availability. Expend for practice.
1000-lb. GP Mk 13 and Mk 13 Mod 1	Being declared obsolete. Limited availability. Expend for practice.
1000-lb. GP Mk 13 Mod 2	Service. None available.
1000-lb. GP AN-M44	Service. None available. Replaced by the AN-M65A1
1000-lb. GP AN-M65	Service. Available. Being replaced by the AN-M65A1.
1000-lb. GP AN-M65A1	Service. Available. (See OCL AV130-43)
1000-lb. SAP AN-M59	Service. Available. Being replaced by the AN-M59A1.
1000-lb. SAP AN-M59A1	Service. Limited availability. (See OCL AV130-43)
1000-lb. AP AN-Mk 33	Service. Available.
1000-lb. Chem. AN-M79	Service. Available NAD Hawthorne. Not procured for general use.
1000-lb. Prac. (WF) Mk 7	Limited availability. Superseded by the Mk 22
1000-lb. Prac. (WF) Mk 22	Service. Limited availability. Production will start February 1945.
1600-lb. AP Mk 1 and Mk 1 Mod 1	Service. Available. (Employs suspension bands)
1600-lb. AP AN-Mk 1	Service. Available. (Employs screw on attachments)
2000-lb. GP AN-M34	Service. Limited availability. Being replaced by the AN-M66A1.
2000-lb. GP AN-M66	Service. Available. Being replaced by the AN-M66A1.
2000-lb. GP AN-M66A1	Service. Limited availability. (See OCL AV130-43)
4000-lb. Dem. AN-M66	Service. Limited availability. (Light Case bomb)

C O N F I D E N T I A L

STATUS AND AVAILABILITY OF AIRCRAFT BOMBS - NAVY AND ARMY DESIGN (cont)

<u>DESIGNATION</u>	<u>STATUS AND REMARKS</u>
4000-lb. Dem. AN-M56A1	Not procured for Naval use as yet. (Light Case bomb). Equip. for Brit. susp.
Signal, Practice Bomb AN-MK 4, Lots 1-100 incl.	These signals will not function on water impact.
<u>CLUSTERS, FRAGMENTATION</u>	
100-lb. Frag. M1 6 bombs 20-lb. AN-M41	Obsolescent, limited availability. Replaced by the AN-M1A2.
100-lb. Frag. AN-M1A1* 6 bombs 20-lb. AN-M41 or AN-M41A1 in cluster-adapters AN-M1A1 or AN-M1A2	Service, available, cluster with AN-M1A1 cluster-adapter not suitable for Navy use, adapter AN-M1A2 (cluster designated SIZVL) will fit.
100-lb. Frag. AN-M1A2* 6 bombs 20-lb. AN-M41A1	Service, available. Fuses will be shipped separately.
100-lb. Frag. AN-M4* 3 bombs 23-lb. AN-M40	Service, available. Will be replaced by the AN-M4A1.
100-lb. Frag. AN-M4A1* 3 bombs 23-lb. AN-M40A1 or AN-M40	Service, available. Fuses will be shipped separately.
100-lb. Frag. M28 24 bombs 4-lb. M83	Service, available. See OCL AV14-44.
500-lb. Frag. M29 90 bombs 4-lb. M83	Service, available, cluster must be assembled before use.
500-lb. Frag. M26 Twenty 20-lb. AN-M41 Frag. Bombs	Formerly T4E4. Available for Army. Not available for Navy.
500-lb. Frag. M27 (T8) 6 bombs 90-lb. M82 (T9)	Service, limited availability. Cluster shipped unassembled.
* These frag. bomb clusters are not recommended for use with external bomb racks on carrier based aircraft. (See OCL AV3-45.)	
<u>CLUSTERS, INCENDIARY</u> <u>SEE OCL AV-79-43</u>	
100-lb. Incend. M2 34 bombs 4-lb. AN-M54	Declared unsuitable for Navy use, to be disposed of per OCL AV3-45.
100-lb. Incend. AN-M6 34 bombs 4-lb. AN-M50A2	Service, stocks exhausted, additional procurement available in 1945.
100-lb. Incend. AN-M8 34 bombs 4-lb. AN-M54 and AN-M54X	Declared unsuitable for Navy use. To be disposed of per OCL AV3-45.
100-lb. Incend. AN-M12 14 bombs 6-lb. AN-M69	Service, stocks exhausted. New stocks available in 1945.
500-lb. Incend. M7 128 bombs 4-lb. AN-M50A2	Service, Available.
500-lb. Incend. M9 128 bombs 4-lb. AN-M54 and AN-M54X	Declared unsuitable for Navy use. To be disposed of per OCL AV3-45.
500-lb. Incend. AN-M13 60 bombs 6-lb. AN-M69	Service Available. See OCL AV129-43.

C O N F I D E N T I A L

STATUS AND AVAILABILITY OF AIRCRAFT BOMBS - NAVY AND ARMY DESIGN (cont)

<u>DESIGNATION</u>	<u>STATUS AND REMARKS</u>
<u>CLUSTERS, INCENDIARY (cont)</u>	
500-lb. Aimable AN-M14 110 bombs 4-lb. AN-M50TAS	Available in 1945. (('T' denotes toxic element present)
500-lb. Aimable AN-M17A1 110 bombs 4-lb. AN-M50A2	Available in 1945.
500-lb. Aimable (EGR2 adapter) 38 bombs 6-lb. AN-M69	Available in 1945.
<u>CLUSTERS, SMOKE</u>	
100-lb. Smoke M21 14 bombs 10-lb. E6	Not under procurement, test unsatisfactory. (E6 bombs WP filled). Army has dropped this bomb from program.
100-lb. Smoke M25 14 bombs 10-lb. M77	Service, available early in 1945. (M77 bombs HC Mixture filled)

STATUS AND AVAILABILITY OF AIRCRAFT BOMB AND BOMB FUZE ACCESSORIES

<u>DESIGNATION</u>	<u>DESCRIPTION AND USE</u>	<u>STATUS AND REMARKS</u>
<u>PRIMER DETONATORS SEE OCL AV18-44</u>		
M14 Non-delay	A removable primer detonator for use in AN-M100, -1, -2A1 and A2 series fuzes. Entire surface painted white.	Available assembled in fuzes AN-M100A2, and as 25% spares for other fuzes.
0.01 Sec.	1/8 sector of base painted black.	Available as 25% spares for the AN-M101, and AN-M102A2.
0.025 Sec.	1/4 sector of base painted black.	Available assembled in fuzes AN-M101A2 and AN-M102A2 and as 25% spares for the AN-M100A2.
0.10 Sec.	Entire base painted black.	Available as 25% spares for the AN-M101, and AN-M102A2.
0.24 Sec.	Entire base painted green.	Will be available on special request only, in early 1945. See Fig. 32
M16 4-5 Sec.	Designed for Minimum Altitude bombing against marine targets (Masthead Bombing).	Available assembled in M112, M113 and M114 fuzes.
8-11 Sec.	Designed for minimum Altitude bombing against land targets (Hedgehop Bombing).	Available as 50% spares for M112 through M117 fuzes.
M16A1 4-5 Sec.	For use in the M112A1 and M115 series fuzes.	Available, superseded the M16.
8-15 Sec.	For use in the M112A1 and M115 series fuzes, will be supplied as 50% spares.	Available, superseded the M16
M19A2 No delay	For use in the M123A1 and M132 series fuzes.	Available. Shipped with but not assembled to the Chemical Time fuzes. See OTJ AV3-44.

C O N F I D E N T I A L

STATUS AND AVAILABILITY OF AIRCRAFT BOMB AND BOMB FUZE ACCESSORIES (cont)

<u>DESIGNATION</u>	<u>DESCRIPTION AND USE</u>	<u>STATUS AND REMARKS</u>
<u>ADAPTER-BOOSTERS</u>		
M102	Installed in all AN-M GP bombs except the AN-M60 series, also installed in all SAP bombs and the 4000-lb. Dem. bomb AN-M56, and the 260-lb. Frax. bomb AN-M81. Designed to receive an Army design tail fuze. May also be procured separately for use in the 500-lb. and 1000-lb. Navy GP bombs to adapt these bombs to take Army fuzes. See OCL VB-43.	Available, installed in bombs and separately. Being superseded by the M102A1.
M102A1	Installed in the AN-M30A1 and 57A1 GP bombs and the A1 and A2 series SAP bombs. For use with anti-withdrawal type fuzes.	Available installed in bombs. See OCL AV130-43.
M115	Installed in the AN-M60 series GP bombs for use with the Navy hydrostatic fuze AN-Mk 230.	Available installed, being superseded by the M115A1.
M115A1	Installed in the AN-M60A1 series bombs for use with anti-withdrawal fuzes.	Available installed. See OCL AV130-43.
M117	For use in the nose fuze seat liner of any Army designed bomb to adapt small mechanical time fuzes of 1-1/2" diameter.	Not as yet procured by the Navy.
<u>BURSTERS AND IGNITERS</u>		
M4	Tetryl burster, for use in M47, M47A1, AN-M47A2 and Mk 28, 100-lb. Smoke bombs (WP, FS or FM).	Available, separately, not installed.
M7	Black Powder burster for use in M47, M47A1, AN-M47A2 and Mk 28, 100-lb. Incend. bombs.	Available, separately, not installed.
M10	Tetryl burster for use in the M70 chemical bomb (115-lb.)	Available separately, not installed.
AN-M12	Black powder and magnesium burster (450 grams of 50/50 mixture) for use in the 100-lb. Incend. bomb AN-M47A2.	None in stock, available from the Army. Does not require an igniter.
AN-M13	TNT and Tetryl burster for use in the 100-lb. Incend. bomb AN-M47A2 with igniter AN-M9 (WP) for land, or igniter AN-M9 (Metallic sodium) for water action.	Available separately. Not to be stowed assembled or with AN-M47A2 bombs and their igniters.
AN-M14	Tetrytol burster for use in the 500-lb. Incend. bomb AN-M76 with the AN-M5 igniter.	Available, not to be stowed in or with bombs or igniters.
AN-M15	Tetrytol burster for use in the 500-lb. Chem. bomb AN-M78.	Available. Does not require an igniter.
AN-M16	Tetrytol burster for use in the 1000-lb. Chemical bomb AN-M79.	Available. Does not require an igniter.
M18	Black powder burster for 100-lb. Smoke Bomb M47A2 (WP filled).	Available, requires no igniter.
(None)	Tetryl burster for use in the 100-lb. Chemical bomb Mk 42. BuOrd Drg. 328343.	Available.
AN-M5	WP igniter for use in the AN-M76 500-lb. Incend. bomb with AN-M14 burster.	Available.
AN-M9	WP igniter for use in the 100-lb. Incend. bomb AN-M47A2 with the AN-M13 burster.	Available.

STATUS AND AVAILABILITY OF AIRCRAFT BOMB AND BOMB FUZE ACCESSORIES (Cont)

<u>DESIGNATION</u>	<u>DESCRIPTION AND USE</u>	<u>STATUS AND REMARKS</u>
<u>BURSTERS AND IGNITERS (Cont)</u>		
AN-M9	Metalllic sodium igniter for use in the 100-lb. Incend. bomb AN-M47A2 with the AN-M13 burster.	Available.
<u>AUXILIARY BOOSTERS</u>		
Mk 1	TNT booster (180 grams) shipped installed in the nose and tail fuze cavities of Navy GP bomb, (over 100-lb.) and all depth bombs. Additional booster Mk 1 is required in the nose fuze cavity when fuze AN-Mk 219 is used.	Available.
Mk 4	TNT booster (63 grams) for use in the nose fuze cavity of AN-GP bombs with fuze AN-Mk 219.	Available.
<u>ADAPTERS AND ADAPTER RINGS</u>		
BO Drg. 294376 Adapter Ring	Designed to adapt fuze AN-Mk 219 to the nose fuze cavities of Navy GP bombs over 100-lb., and AN-GP bombs 100-lb. and over.	Available.
BO SK 99752 Spacer Ring	Designed to fit under adapter-boosters M102, or M102AL when inserted into tail fuze cavities of Navy bombs for Army tail fuzes.	To be made up locally. See OCL V8-43.
BO Drg 341704H Adapter (Inner Sleeves)	Designed to adapt the Army tail fuzes to the M115 or M115AL adapter-boosters of AN-GP bombs.	Available installed in all AN-M80 series GP bombs.
<u>BANDS, TRUNNION, HOISTING, AND SUSPENSION</u>		
M1A1	Trunnion-hoisting, for bombs 500-lb. AN-M43 & 64	Available.
M2A1	Trunnion-hoisting for bombs 1000-lb. AN-M44 & 65	Available.
M4	Trunnion-hoisting for bombs 500-lb. SAP.	Available.
M5	Trunnion-hoisting for bombs 1000-lb. SAP.	Available. ( See P. 36)
AN-M7	Trunnion-hoisting for bombs 2000-lb. AN-M34 & 66	Not procured by the Navy.
AN-M8	Trunnion-hoisting for bombs 4000-lb. AN-M56.	Not procured by the Navy
BO Drg 294244	Trunnion band for bombs 500-lb. GP Mk 12 Mod 2.	Available.
BO Drg 294242	Trunnion band for bombs 1000-lb. GP Mk 13 Mod 2	Available.
BO Drg 328386	Trunnion-hoisting for bombs 1600-lb. AP Mk 1	Available.
BO Drg 387706	Trunnion band for Depth bombs Mk 17 and Vogs, AN-MK 41, & AN-Mk 47	Available.
Mk 10	Trunnion-hoisting-suspension band to adapt bombs 2000-lb. AN-M34 & 66 to 14" suspension. Has hoisting lugs, and trunnions (screw-in type).	Available in February 1945.

C O N F I D E N T I A L

STATUS AND AVAILABILITY OF AIRCRAFT BOMB AND BOMB FUZE ACCESSORIES (Cont)

DESIGNATION	DESCRIPTION AND USE	STATUS AND REMARKS
<b><u>ARMING WIRE ASSEMBLIES</u></b>		
Mk 1	Single strand (.064" diam.) wire for bombs using one fuse up to the 2000-lb. GP bombs.	Available early in 1945. (100 wires and 300 Fahnestock clips per air-tight can)
Mk 2	Double strand (.064" diam.) wire for bombs using two fuses up to the 2000-lb. GP bombs.	Available early in 1945. (50 wires and 300 Fahnestock clips per air-tight can)
Mk 3	Single strand (.033" diam.) steel wire for all bombs and clusters using M11A2 type fuses.	Available early in 1945. (100 wires and 100 Fahnestock clips per air-tight can)
Mk 1	Arming Wire Extension (.0626" diam.) cable for all clusters, and the 4000-lb. bombs.	Available early in 1945. (100 per air-tight can)



R E S T R I C T E D

**5"/38 W.P. SMOKE PROJECTILE**  
**(5"/38 Illuminating Projectile Body Mk 30)**

DESCRIPTION

Technical data for the 5"/38 W. P. Smoke Projectile, Fig. 8,  
are as follows:

Overall Length:	
With Nose Fuse	8070
Without Nose Fuse	1578
Diameter of Base	42975
Distance - Base to Band	2745
Width of Band	2726
Diameter of Bourrelet	47985
Type of Filling:	
Expelling Charge	2 oz. Black Powder
Bursting Charge	14 grams Ballistite
W. P.	7.06 lbs
Weight of Loaded Projectile	53.0 lbs. (approx)
Cartridge Case	Mk 5
Primer	Mk 13 or Mk 13 Mod 1
Tracer	None
Fuzes which may be used	Nose: Mk 18 Mod 3 or 4 Mk 50

This projectile is specially painted and marked to indicate its contents. As shown in the color scheme in Fig. 8, the nose fuze is unpainted; immediately aft of the nose fuze is a 2-1/2" band of slate grey which is followed by a 2-1/2" band of red; around the body, 2-7/8" below the bourrelet, is a 1/2" band of yellow; the remainder of the body is painted blue grey with the exception of the bourrelet and rotating band which are unpainted.

Lettering on the body is stencilled with yellow spraying lacquer. Other pertinent data are stamped on the base.

The projectile body, fuze, base plate and expelling charge are the same as the 570 Illuminating Projectile Mk 30 (See page 69, "U. S. Navy Projectiles and Fuzes" published by B.D.S.).

The cannister, holding the W. P. filled tubes, is of one piece drawn construction, made of hot rolled sheet steel 0703 thick. The cannister is 12403 long and 319 in diameter. It is painted olive drab over-all. Through the center of the cannister a burster tube is inserted containing 14 grams of flaked ballistite with a black powder delay fitted to the upper end of the burster tube.

The cannister is divided into four sections internally with each section containing 42 W. P. filled steel tubes 075 in diameter and 2786 long (total of 168 tubes). The cannister is filled through the base with molten W. P. and closed with two 1/2" pipe plugs.

OPERATION

When the projectile is fired, the mechanical time fuze functions at the predetermined setting igniting the black powder expelling charge. The expelling charge has two functions: (1) it ignites the delay at the upper end of the burster tube, and (2) forces the base plate off and ejects the cannister rearward. The delay then sets off the burster which ruptures the case of the cannister and distributes the W. P. filled steel tubes through the air. The smoke cloud formed is approximately 30-40 yards in diameter. The small W. P. filled steel tubes are used to help bring the smoke screen to the surface of the water when low bursts are desired to screen amphibious assault troops.

USE

1. Anti-personnel weapon with psychological effect.
2. W. P. has some incendiary value against very inflammable targets although it is not as effective in this case as magnesium, thermite or gasoline gel.

RESTRICTED

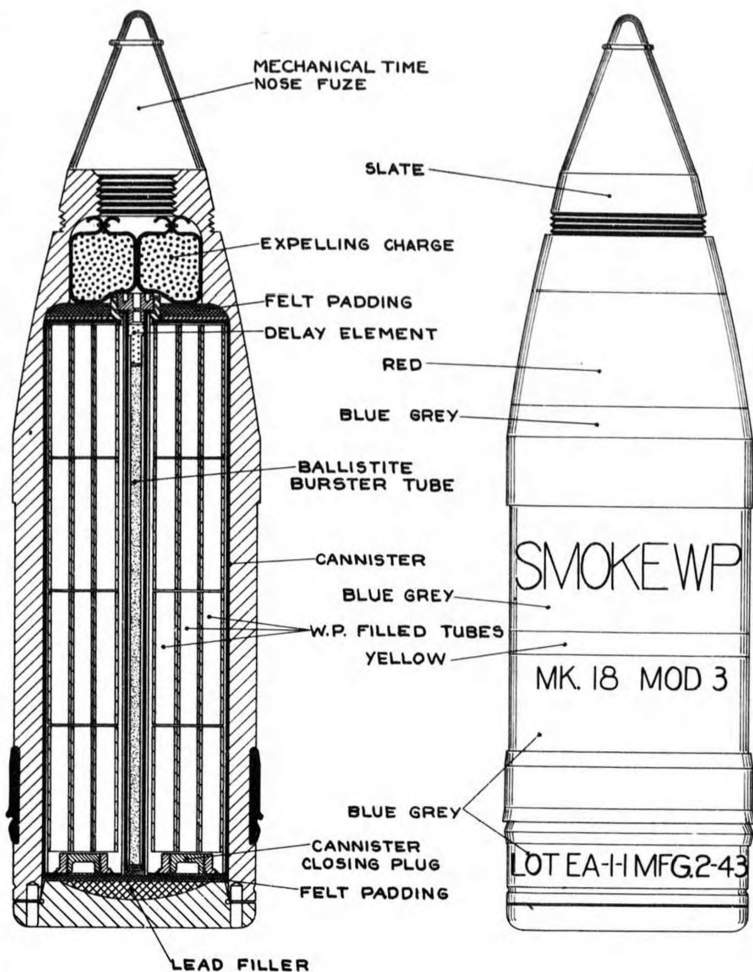

**FIG. 8**  
**5/38 W.R (SMOKE) PROJECTILE**

3. Can be used for spotting but is not capable of being controlled with extreme accuracy.
4. Laying surface smoke screens at sea.
5. Screening amphibious assault troops.
6. Blinding enemy gun positions.
7. Blinding batteries of enemy capital ships to permit destroyer torpedo attacks.
8. Blinding enemy troops ashore.

#### STOWAGE AND HANDLING

Since the canisters are tested at high pressure and are contained within the sealed projectile case, the projectiles present no great hazard to stowage. However, since any leakage or malfunctioning in stowage would be accompanied by quantities of acrid smoke and fires which are difficult to permanently extinguish, the projectiles should be placed in improvised topside stowage which will lend itself to ready jettisoning of projectiles, if necessary.

#### PRECAUTIONS

W. P. burns at a relatively low temperature and is readily extinguished by water. However, due to its ability to ignite spontaneously when in contact with air, an extinguished fire may reignite when the W. P. dries out. A solution of a few per cent of copper sulfate in water will remove this danger and extinguish fires permanently.

(NOTE: The range table for this projectile in O.P. 1042 is currently being revised and will shortly be issued by BuOrd.

-----

C O N F I D E N T I A L

### 0.24 SEC. DELAY PRIMER DET. M14

As a result of development work conducted by BuOrd, the Army has, at the request of BuOrd, incorporated a delay of 0.24 seconds in the design of Primer Detonator M14 for use in bomb tail fuzes of the AN-M100A2 series. The delays now available are:

- (1) Non delay
- (2) 0.01 sec.
- (3) 0.025 sec.
- (4) 0.1 sec.
- (5) 0.24 sec.

When the water discriminating bomb nose fuze Mk 243 was developed, it was recommended that for high angle impacts the Mk 243 be used with a tail fuze of the AN-M100A2 series fitted with a primer detonator M14 with 0.1 seconds delay. The purpose of the above combination was to obtain in the same bomb the maximum destructive effect from a direct hit on a ship or a near miss alongside. In the event of a direct hit, the nose fuze Mk 243 would function with a delay of 0.025 seconds, and in the event of a water impact the nose fuze would not function and detonation of the bomb would consequently be controlled by the tail fuze alone.

Subsequent experiments with longer fixed delays than the 0.1 seconds mentioned above have shown that a delay of 0.24 seconds is suitable for dive, glide, and horizontal bombing. In glide and horizontal bombing tests, using a delay of 0.24 seconds, 500-lb. GP bombs with velocities of 400-500 f.s. and entrance angles of 60° from the horizontal, detonated at depths of about 26'. Similar tests using 1000-lb. bombs gave about the same results, and tests using 2000-lb. bombs resulted in detonations about 13' deeper. In dive bombing tests, when 250-lb. and 500-lb. bombs were released at 3000' altitude in a 60° dive at 300 knots, detonations resulted at depths of 27'-29'. Dive bombing tests using 1000-lb. bombs

In view of the above tests, BuOrd recommends that the primer detonator M14 with 0.24 seconds delay be used in fuzes of the AN-M100A2 series as a companion fuze to the nose fuze Mk 243 with 0.025 seconds delay. This combination is recommended for all anti-shipping attacks in which the desired fuze delay for direct hits is 0.025 seconds. It is emphasized, however, that fuzes with this delay are not suitable for skip, masthead, or low altitude glide bombing attacks, since there is insufficient delay in the fuze to protect the releasing aircraft.

from serious damage.

Among the advantages of a fuze combination with the primer detonator M14 over that employing a hydrostatic tail fuze are the following:

- (a) On a direct hit both the nose and tail fuzes will function.
- (b) From higher altitudes a pyrotechnic delay is more reliable than a hydrostatic tail fuze due to the high velocity of entry.
- (c) The tail fuze will function if the bomb is dropped on a secondary land target, whereas the nose fuze Mk 243 Mod 0 may not function on impact with soft ground.
- (d) The primer detonator is easier to produce and handle than the hydrostatic tail fuze.

These special primer detonators M14 (0.24 seconds delay) are being produced and will be issued to the Fleet as soon as possible. The base is painted with a green lacquer to indicate the special delay. BuOrd will appreciate receiving early performance reports of the 0.24 second delay primer detonators M14.

-----  
REFERENCE: Bulletin of Ordnance Information 4-44.

\*\*\*\*\*

C O N F I D E N T I A L

### **USE OF INCENDIARY & H.E. BOMBS AGAINST JAPANESE TYPE STRUCTURES**

Tests were recently conducted to obtain data on the most effective method for using H.E. bombs, in conjunction with incendiary bombs, against those Japanese area targets which consist mainly of closely spaced wooden structures. It was desired to determine the comparative effectiveness of demolition bombs dropped before, during and after incendiary bombs, the optimum load ratio of incendiaries to H.E. bombs and the method of release to be used. The bombs used for these tests were clusters of AN-M69 6-lb. oil incendiaries, AN-M41 20-lb. fragmentation bombs, and the AN-M50 100-lb. G.P. bomb fuzed with the AN-M103.

#### CONCLUSIONS

1. The optimum load ratio for incendiary attack on Japanese targets, consisting mainly of relatively light one and two-story structures, is 80 per cent incendiaries and 20 per cent fragmentation bombs, released to produce approximately simultaneous impact in a co-extensive pattern. This load ratio is also the most effective means of obtaining an adequate anti-personnel effect while retaining close to the maximum incendiary load.
2. Demolition bombs are not effective when used against Japanese type wooden structures in conjunction with incendiary bombs for the following reasons:
  - (a) Structures wrecked by demolition bombs are less susceptible to incendiary action than intact structures.
  - (b) Demolition bombs exploding in fires already in progress reduce the intensity and spreading capacity of the fires.
  - (c) The wreckage caused by demolition bombs tends to act as a fire break.
3. The AN-M69 incendiary bomb is capable of initiating destructive fires in Japanese type wooden structures when the fires are initiated in relatively inaccessible locations or when they are left unattended in the early stages of fire development.
4. For use on Japanese type wooden structures in conjunction with incendiaries, the fragmentation bomb has the following advantages over the demolition bomb:
  - (a) It tends to eliminate or drive undercover first line fire-fighting personnel during the critical stage of fire development while leaving the target structures largely intact.

- (b) The 500-lb. frag. cluster provides better target coverage than an equivalent load of demolition bombs.

A number of factors which might have critical effects on actual operations, such as weather, enemy morale, and efficiency of enemy personnel and equipment, could not be included in the tests. Nevertheless, the test results are sufficiently clear-cut to make them applicable in general to concentrated Japanese urban areas, consisting mainly of relatively light one and two-story structures.

- - - - -

REFERENCE: Naval Aviation Confidential Bulletin 1-45.

\* \* \* \* \*

C O N F I D E N T I A L

## MULTIPLE SUSPENSION OF BOMBS

### INCREASED CARRYING CAPACITY

The results of recent tests conducted at NAS Patuxent River indicate considerable success in increasing bomb carrying capacity of the TBF and SBD Aircraft by use of the M12 Cluster Adapter. The TBF can carry a maximum of eight 2-bomb clusters plus 4 single bombs, making a total load of twenty 100-pound GP bombs. (See Fig. 9) The SBD can carry one 3-bomb cluster on each Mk 51 wing rack, but care must be exercised when loading to reduce the possibility of hang-ups.

BuAer T.O. 92-44, dated 17 July 1944, describes the use of Cluster Adapter M12 (see AFPO Bulletin No. 3, page 41) to increase bomb carrying capacity. Complete instructions for loading are given and precautions to be taken are pointed out. It should be especially noted that this T.O. prohibits the use of the M12 Cluster Adapter for increasing the bomb loading of aircraft which are to be subjected to catapulting, dive bombing, arrested landings or any violent maneuvers.

### DRAG PLATES

In order for the second bomb of a 2-bomb cluster to have a reasonably separated ground impact from that of the first bomb from low altitudes of attack, some means of increasing its air resistance must be provided. A plywood plate of a suitable size to produce the desired trail, securely wired to the bomb tail fins, is the simplest means by which this may be accomplished. However, the use of drag plates of this type precludes the use of a tail fuze in bombs so equipped.

For the TBF aircraft it was found that a 14" square plywood plate was the largest that could be satisfactorily loaded. Six clusters can be carried on the lower stations, and two on the forward upper stations. A cluster of two bombs cannot be loaded on the upper center and aft stations because of structural interference. At these stations a single bomb is carried in the conventional manner.

Tests with the SBD showed that three-bomb clusters of 100-pound GP bombs using M12 cluster adapters could be satisfactorily loaded, and when equipped with the proper size drag plates on the outer bombs gave a reasonably uniform pattern. A cluster with one bomb clean, one with an 8 inch square plate, and one with an 11 inch square plate gave a pattern length of about 120 feet when dropped at an average speed of 170 knots. Two clusters equipped with these drag plates decrease the cruising speed 13 knots compared to a cruising speed of 135 knots with clean clusters.

For the 6" square plate, 1/4 inch plywood proved strong enough. But for larger plates 3/8 inch or 1/2 inch plywood should be used. Four round turns of 1/32 inch steel safety wire proved strong enough to hold on the plates. The plates should be set in a reasonably symmetrical position on the tail to prevent oscillation.

- - - - -

REFERENCE: Naval Aviation Confidential Bulletin No. 12-44.

\* \* \* \* \*

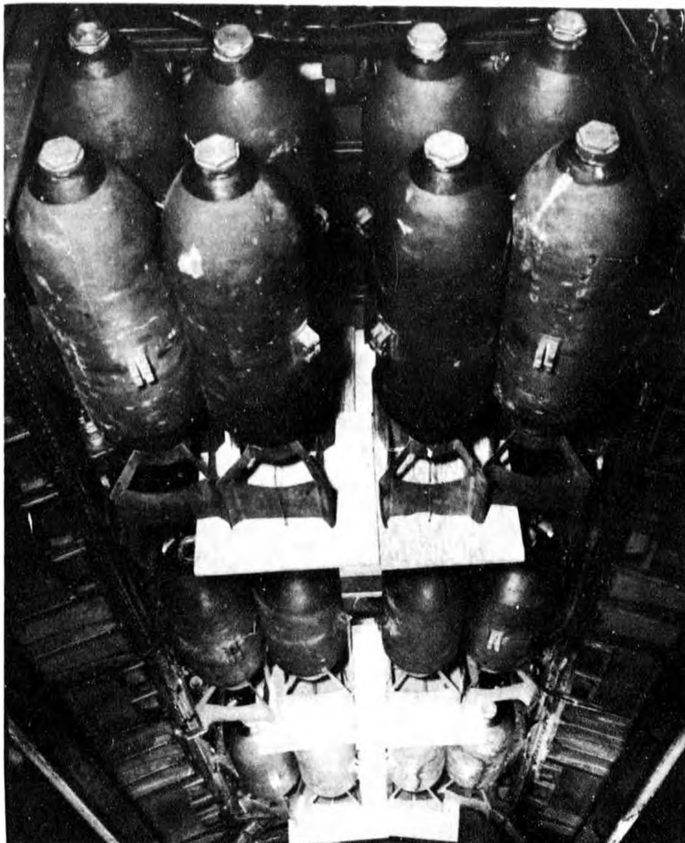

FIG. 9. TEF BOMB BAY SHOWING INCREASED CARRYING CAPACITY ACHIEVED THROUGH MULTIPLE SUSPENSION OF 100-lb. GP BOMBS BY MEANS OF CLUSTER ADAPTER, M12.

R E S T R I C T E D

### **IGNITER, AN-M9 (WP) AND (Na)**

Igniter AN-M9 (W.P.), used in conjunction with Burster AN-M13 for the AN-M47A2 incendiary bomb, is now available as a separate item with an Na (Sodium) filling. The Na igniter will permit use of the AN-M47A2 over water. No separate nomenclature has been assigned the Na igniter. The igniter will be known as "Igniter, AN-M9 (WP)" or "Igniter AN-M9 (Na)".

## BURSTER, M18

### DESCRIPTION

The Burster, M18, has been developed to provide a suitable burster for the 100-lb. White Phosphorus Smoke Bomb, M47A2. It is a modification of the standard M7 Burster, usually employed in the M47A2 Bomb. The M18 Burster is expressly designed for use with white phosphorus fillings.

It has been found that the standard Bursters, M4 and M7, break the white phosphorus filling into such small particles that it burns very rapidly, evolving a great deal of heat, which causes the smoke to rise rapidly or "pillar", resulting in an inefficient smoke screen. A series of tests indicated that by filling the M7 Burster to half its length with a block of wood and then inserting the black powder, thereby reducing the explosive charge by half, a more effective smoke screen is produced. For bombing at altitudes of 10,000 feet or less, the M18 Burster is more satisfactory than either the M7 or the M4. At higher altitudes, however, where the bomb becomes deeply buried on impact, a more powerful charge, such as that contained in the M4 Burster, may be required to obtain proper dispersion of the white phosphorus.

### RELATED ITEMS

Burster M4, which contains 680 grams of tetryl, and Burster M7, which contains 600 grams of black powder, are both standard. Experimental bursters have been made by partly filling both the M4 and M7 with inert materials, such as sand, to reduce their bursting power, but in general the M18 is the most satisfactory for bombing from altitudes up to 10,000 feet.

### SHIPPING

The M18 Burster will be supplied in addition to the M4 for each 100-lb. WP Smoke Bomb, for optional use depending upon tactical requirements.

-----

REFERENCE: New Material, August 1944.

\*\*\*\*\*

R E S T R I C T E D

## MODIFICATION TO TRUNNION BAND M5

By means of FAVORO OMI V31-44, the Bureau of Ordnance has issued instructions modifying the standard trunnion band M5 for the 1000-lb. SAP bomb AN-M59 or AN-M59A1 so that two of these bombs may be carried in the bomb bay of SB2C type aircraft as shown in Fig. 10. The distance between the ends of the trunnions on the band M5 is 23F5. SB2C aircraft are equipped so as to provide either one displacing gear which will engage trunnions having 23F5 spacing, or two displacing gears having forks designed to engage trunnions of 19F0 spacing. It is possible, by modifying the trunnion band M5 so that the distance between the ends of the trunnions is reduced to 19F0, to install two 1000-lb. SAP bombs in the SB2C.

The modification is optional and should be limited to trunnion band M5. The work can be done by aviation metalmiths or qualified personnel of similar rating.

### INSTRUCTIONS FOR ACCOMPLISHING WORK

1. If the trunnion band M5 is already attached to the bomb, it must be removed before any work is started.
2. Using a hack saw, cut the trunnion from the band as close as possible to the weld. Grind or file smooth the surfaces of the band where the trunnions were cut off to provide smooth, flat surfaces.
3. Machine or grind the bases of the trunnions so that the overall length is reduced to 1-23/32 inch.
4. Properly position and butt weld the shortened trunnions in place against the trunnion band. When the welding operations are completed, make certain that the trunnions are in correct alignment. Check the band for proper fit in the displacing gear forks.

5. Test the newly welded trunnions by applying a 500-lb. load to each trunnion. It is suggested that this test be accomplished by installing the modified trunnion band, M5, on the 1000-lb. SAP bomb in the conventional manner. Utilising two hoists of the AN-Mk 7 or Mk 8 type, fasten each cable around the centers of the shanks of the trunnions, and then raise the bomb several inches. Make sure that the total weight of the bomb is supported by the trunnions and that the load is distributed equally. After lowering the bomb and removing the cables, a careful inspection should not disclose any cracks in the new welds and there should be no permanent deformation of the trunnions.
6. The modified trunnion band is positioned on the 1000-lb. SAP bomb (AN-M59 or AN-MC9A1) in the conventional manner before loading into the bomb-bay of the SB2C. The bombs are installed, one on each of the two outboard racks, and the port and starboard displaing gears engaged. In loading, the starboard bomb should be installed first; the port bomb may then be loaded without working under the starboard bomb. After both bombs are loaded, their tail assemblies should be adjusted by rotating to insure that the outer edges of the fins will clear the bomb-bay hinges. By visual inspection, check the fin positions to assure ample clearance on release. When the correct tail fin positions have been established, the fin lock nuts should be securely tightened.

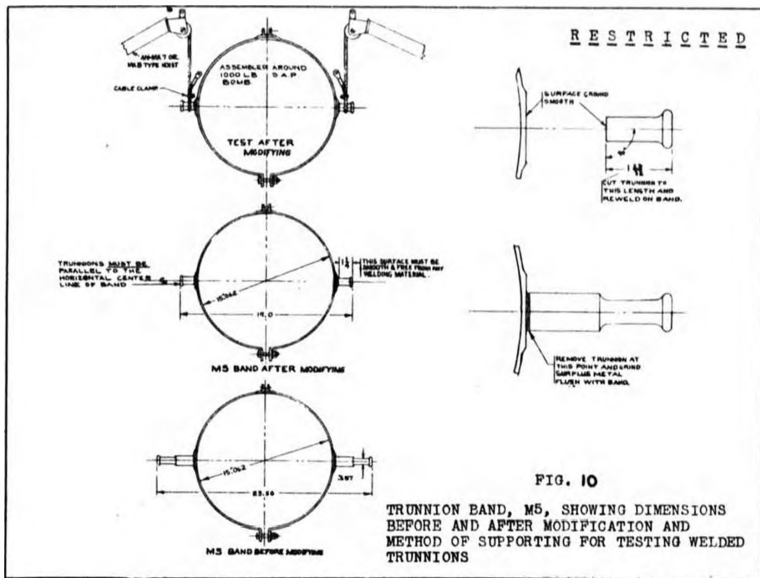

#### PRECAUTIONS

The following special precautions are re-emphasized in conjunction with the work of modifying the trunnion band, M5:

1. No work should be attempted on the Trunnion Band, M5, until the band has been removed from the 1000-lb. SAP bomb. The modification will be expedited by taking the band to a shop where suitable welding equipment and tools may be employed.
2. When welding the trunnions to the band, it is important that the trunnions are kept in horizontal alignment and that the distance between ends of the trunnions does not exceed 1970.

**BURSTER, M18**DESCRIPTION

The Burster, M18, has been developed to provide a suitable burster for the 100-lb. White Phosphorus Smoke Bomb, M47A2. It is a modification of the standard M7 Burster, usually employed in the M47A2 Bomb. The M18 Burster is expressly designed for use with white phosphorus fillings.

It has been found that the standard Bursters, M4 and M7, break the white phosphorus filling into such small particles that it burns very rapidly, evolving a great deal of heat, which causes the smoke to rise rapidly or "pillar", resulting in an inefficient smoke screen. A series of tests indicated that by filling the M7 Burster to half its length with a block of wood and then inserting the black powder, thereby reducing the explosive charge by half, a more effective smoke screen is produced. For bombing at altitudes of 10,000 feet or less, the M18 Burster is more satisfactory than either the M7 or the M4. At higher altitudes, however, where the bomb becomes deeply buried on impact, a more powerful charge, such as that contained in the M4 Burster, may be required to obtain proper dispersion of the white phosphorus.

RELATED ITEMS

Burster M4, which contains 680 grams of tetryl, and Burster M7, which contains 500 grams of black powder, are both standard. Experimental bursters have been made by partly filling both the M4 and M7 with inert materials, such as sand, to reduce their bursting power, but in general the M18 is the most satisfactory for bombing from altitudes up to 10,000 feet.

SHIPPING

The M18 Burster will be supplied in addition to the M4 for each 100-lb. WP Smoke Bomb, for optional use depending upon tactical requirements.

REFERENCE: New Materiel, August 1944.

\*\*\*\*\*

R E S T R I C T E D

**MODIFICATION TO TRUNNION BAND M 5**

By means of Wavord OMI V31-44, the Bureau of Ordnance has issued instructions modifying the standard trunnion band M5 for the 1000-lb. SAP bomb AN-M59 or AN-M59A1 so that two of these bombs may be carried in the bomb bay of SB2C type aircraft as shown in Fig. 10. The distance between the ends of the trunnions on the band M5 is 2375. SB2C aircraft are equipped so as to provide either one displacing gear which will engage trunnions having 2375 spacing, or two displacing gears having forks designed to engage trunnions of 1970 spacing. It is possible, by modifying the trunnion band M5 so that the distance between the ends of the trunnions is reduced to 1970, to install two 1000-lb. SAP bombs in the SB2C.

The modification is optional and should be limited to trunnion band M5. The work can be done by aviation metalsmiths or qualified personnel of similar rating.

INSTRUCTIONS FOR ACCOMPLISHING WORK

1. If the trunnion band M5 is already attached to the bomb, it must be removed before any work is started.
2. Using a hack saw, cut the trunnion from the band as close as possible to the weld. Grind or file smooth the surfaces of the band where the trunnions were cut off to provide smooth, flat surfaces.
3. Machine or grind the bases of the trunnions so that the overall length is reduced to 1-25/32 inch.
4. Properly position and butt weld the shortened trunnions in place against the trunnion band. When the welding operations are completed, make certain that the trunnions are in correct alignment. Check the band for proper fit in the displacing gear forks.

5. Test the newly welded trunnions by applying a 500-lb. load to each trunnion. It is suggested that this test be accomplished by installing the modified trunnion band, M5, on the 1000-lb. SAP bomb in the conventional manner. Utilizing two hoists of the AN-EK 7 or EK 8 type, fasten each cable around the centers of the shanks of the trunnions, and then raise the bomb several inches. Make sure that the total weight of the bomb is supported by the trunnions and that the load is distributed equally. After lowering the bomb and removing the cables, a careful inspection should not disclose any cracks in the new welds and there should be no permanent deformation of the trunnions.
6. The modified trunnion band is positioned on the 1000-lb. SAP bomb (AN-M59 or AN-M59A1) in the conventional manner before loading into the bomb-bay of the SB2C. The bombs are installed, one on each of the two outboard racks, and the port and starboard displacing gears engaged. In loading, the starboard bomb should be installed first; the port bomb may then be loaded without working under the starboard bomb. After both bombs are loaded, their tail assemblies should be adjusted by rotating to insure that the outer edges of the fins will clear the bomb-bay hinges. By visual inspection, check the fin positions to assure ample clearance on release. When the correct tail fin positions have been established, the fin lock nuts should be securely tightened.

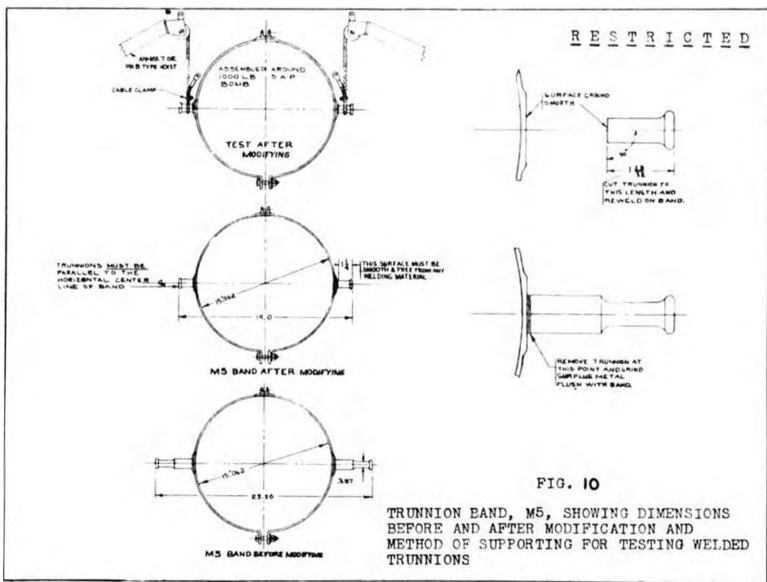

#### PRECAUTIONS

The following special precautions are re-emphasized in conjunction with the work of modifying the trunnion band, M5:

1. No work should be attempted on the Trunnion Band, M5, until the band has been removed from the 1000-lb. SAP bomb. The modification will be expedited by taking the band to a shop where suitable welding equipment and tools may be employed.
2. When welding the trunnions to the band, it is important that the trunnions are kept in horizontal alignment and that the distance between ends of the trunnions does not exceed 1970.

3. If a live-loaded bomb is used for testing, extreme care should be exercised, and the bomb raised only a few inches above the deck.
4. Due to the space limitations in the bomb-bay of the SB2C type aircraft, the bomb tails must be rotated so that the fins will clear the bomb-bay door hinges when the bombs are released. A careful check must be made of the tail fin positions to insure a free fall.
5. After the tail adjustments are made, the fin lock nuts must be securely tightened.

REFERENCE: NavOrd OMI V31-44

\* \* \* \* \*

### SUGGESTED READING

(Restricted)

1. O.P. 1125, "Chemical Spraying Equipment", dated 29 September 1944.

This O.P. contains information on Navy aircraft smoke and chemical tanks and related equipment as well as instructions on handling, etc.

(Restricted)

2. O.P. 1050, First Revision, "Aircraft Smoke Bombs", dated 30 October 1944.

This Ordnance Pamphlet was recently revised and contains detailed information on the following items:

- 50-lb. Aircraft Smoke Bomb Mk 1 Mods 1 and 2
- 100-lb. Aircraft Smoke Bomb Mk 3 Mod 0
- 100-lb. Quick Opening Cluster M25 of 14 10-lb. HC Smoke Bombs M77

It also includes details on safety precautions and maintenance.

(Unclassified)

3. Circular Letter V-31, "Stowage In and Removal of Explosives and Pyrotechnics from Aircraft After Flights", (Originally issued on 29 March 1940 and reissued in December 1944).

This letter has been reissued in order to impress upon all activities concerned the importance of removing explosives and pyrotechnics from aircraft after flights.

(Restricted)

4. NavOrd OCL A2-45, "Non-Explosive 40 mm Tracer Ammunition For Use Against Target Drones - Issue of", dated 3 January 1945.

About 1 February 1945 it is expected that this new round of non-explosive 40 mm tracer ammunition will be made available to all antiaircraft training centers upon request.

(Restricted)

5. O.P. 1315, "Bombing Table for Use with Droppable Fuel Tanks," dated 27 November 1944.

This pamphlet contains the necessary sighting data for use when bombing from F6F and F4U type aircraft with droppable fuel tanks equipped with stabilizing fins and sighting by means of a fixed gunsight graduated in mils.