

UNCLASSIFIED

AD NUMBER

ADB021557

LIMITATION CHANGES

TO:

Approved for public release; distribution is unlimited.

FROM:

Distribution authorized to U.S. Gov't. agencies only; Test and Evaluation; SEP 1976. Other requests shall be referred to Air Force Armament Lab., Eglin AFB, FL.

AUTHORITY

USADTC ltr 2 Apr 1980

THIS PAGE IS UNCLASSIFIED

THIS REPORT HAS BEEN DELIMITED
AND CLEARED FOR PUBLIC RELEASE
UNDER DOD DIRECTIVE 5200.20 AND
NO RESTRICTIONS ARE IMPOSED UPON
ITS USE AND DISCLOSURE.

DISTRIBUTION STATEMENT A

APPROVED FOR PUBLIC RELEASE;
DISTRIBUTION UNLIMITED.

2

AFATL-TR-76-105 ✓



**DEVELOPMENT OF XM714A3
DELAY FUNCTION FUZE**

**HONEYWELL INC.
GOVERNMENT AND AERONAUTICAL PRODUCTS DIVISION
HOPKINS, MINNESOTA 55343**

ADB021557

SEPTEMBER 1976



FINAL REPORT: DECEMBER 1975 - AUGUST 1976

Distribution limited to U. S. Government agencies only; this report documents test and evaluation; distribution limitation applied September 1976. Other requests for this document must be referred to the Air Force Armament Laboratory (DLD), Eglin Air Force Base, Florida 32542.

AD NO. _____
DDC FILE COPY

AIR FORCE ARMAMENT LABORATORY

AIR FORCE SYSTEMS COMMAND • UNITED STATES AIR FORCE

EGLIN AIR FORCE BASE, FLORIDA



**Best
Available
Copy**

| | | | |
|--|--|--|--|
| <p>(18) (17) REPORT DOCUMENTATION PAGE</p> | | <p>READ INSTRUCTIONS BEFORE COMPLETING FORM</p> | |
| <p>1. REPORT NUMBER AFATL TR-76-105 ✓</p> | | <p>2. GOV'T ACCESSION NUMBER</p> | |
| <p>4. TITLE (AND SUBTITLE) DEVELOPMENT OF XM714A3 DELAY FUNCTION FUZE.</p> | | <p>5. TYPE OF REPORT/PERIOD COVERED Final Report, December 1975-to August 1976.</p> | |
| <p>7. AUTHOR(S) Robert L. Aske</p> | | <p>6. PERFORMING ORG. REPORT NUMBER 46552 ✓</p> | |
| <p>9. PERFORMING ORGANIZATIONS NAME/ADDRESS Honeywell Inc. Government and Aeronautical Products Division Hopkins, Minnesota 55343</p> | | <p>8. CONTRACT OR GRANT NUMBER(S) F08635-76-C-0139</p> | |
| <p>11. CONTROLLING OFFICE NAME/ADDRESS Air Force Armament Laboratory Armament Development and Test Center Eglin Air Force Base, Florida 32542</p> | | <p>10. PROGRAM ELEMENT, PROJECT, TASK AREA & WORK UNIT NUMBERS Program Element 64603F JAN 2079-01-05</p> | |
| <p>14. MONITORING AGENCY NAME/ADDRESS (IF DIFFERENT FROM CONT. OFF.) 119p.</p> | | <p>12. REPORT DATE September 1976</p> | |
| | | <p>13. NUMBER OF PAGES 119</p> | |
| | | <p>15. SECURITY CLASSIFICATION (OF THIS REPORT) Unclassified</p> | |
| | | <p>15a. DECLASSIFICATION DOWNGRADING SCHEDULE</p> | |
| <p>16. DISTRIBUTION STATEMENT (OF THIS REPORT) Distribution limited to U. S. Government agencies only; this report documents test and evaluation; distribution limitation applied September 1976. Other requests for this document must be referred to the Air Force Armament Laboratory (DLD), Eglin Air Force Base, Florida 32542.</p> | | | |
| <p>17. DISTRIBUTION STATEMENT (OF THE ABSTRACT ENTERED IN BLOCK 20, IF DIFFERENT FROM REPORT)</p> | | | |
| <p>18. SUPPLEMENTARY NOTES Available in DDC</p> | | | |
| <p>19. KEY WORDS (CONTINUE ON REVERSE SIDE IF NECESSARY AND IDENTIFY BY BLOCK NUMBER) Ordnance Cartridge Ammunition Explosive Test Fuzing Delay Function Projectile</p> | | | |
| <p>20. ABSTRACT (CONTINUE ON REVERSE SIDE IF NECESSARY AND IDENTIFY BY BLOCK NUMBER) This report documents the advanced engineering of the XM714A3, a delay version of the XM714 fuze family. The fuze was characterized to provide delay function of a light-weight thin-wall 20mm High Explosive Incendiary (HEI) projectile to be used for air-to-air combat missions. The program objectives were met within the defined schedule as summarized:</p> | | | |

HD-168 REV 11/74

406410

(20)

- A function delay of 10 ±4 inches (9 inches, nominal delay required) was demonstrated at 0 to 80 degrees obliquity, 2500 to 3500 ft/s impact velocity against 0.06- to 0.125-inch 2024-T3 aluminum targets.
- The fuze was packaged within the 1.2-inch-long ogive profile.
- Bore safety and reliable arming within 100 feet was provided.
- Selected MIL-STD-331/MIL-STD-810B safety requirements were demonstrated.
- No self-destruct and no function against simulated rain target was demonstrated.
- Projectile length, protrusion, weight, and charge-mass ratio (C/M) requirements were met.
- Five hundred XM714A3 fuzed projectiles were shipped on schedule and successfully demonstrated the performance envelope of the fuze in a test series conducted by the Air Force.
- A unit product cost estimate for the fuze was generated and furnished to the Air Force.

| | | |
|---------------------------------|--|--|
| AC | | |
| MIS | | |
| DDC | | |
| UNANNOUNCED JUSTIFICATION | | |
| BY _____ | | |
| DISTRIBUTION/AVAILABILITY CODES | | |
| Dist. AVAIL. and/or SPECIAL | | |
| B | | |

PREFACE

This final report was prepared by Honeywell Inc., Government and Aeronautical Products Division, Hopkins, Minnesota 55343, under Contract No. F08635-76-C-0139 with the Air Force Armament Laboratory, Eglin Air Force Base, Florida. The period covered is December 1975 to August 1976.

The Air Force Armament Laboratory Program Manager was Mr. Seymour Slotkin, SD20.

This technical report has been reviewed and is approved for publication.

FOR THE COMMANDER



Gerald P. D'Arcy, Colonel USAF
Chief, Guns, Rockets and Explosives Division

TABLE OF CONTENTS

| Section | Title | Page |
|---------|--|------|
| I | INTRODUCTION | 1 |
| II | SUMMARY | 5 |
| III | DESIGN ANALYSIS | 9 |
| | Requirements | 9 |
| | Design Approach | 11 |
| | Description | 11 |
| | Operation | 13 |
| | Technical Risks | 17 |
| | Delay Function Analysis | 18 |
| | Arming Delay Analysis | 19 |
| | Physical Parameters | 19 |
| | Ogive Material Study | 19 |
| | Stress Analysis | 23 |
| | Hazard Analysis | 24 |
| IV | FUZE EVALUATION | 25 |
| | Planned Versus Actual Tests | 25 |
| | Early Tests | 25 |
| | Structural Integrity Gun Tests | 27 |
| | Delay Function Gun Tests | 33 |
| | Laboratory Tests | 37 |
| | Final Tests | 42 |
| | Supplemental Tests | 48 |
| | Lot Acceptance Tests | 53 |
| | Eglin Tests | 55 |
| | Structural Integrity Gun Tests | 55 |
| | Delay Function Gun Tests | 56 |
| | Target-Velocity Spectrum Comments | 57 |
| | Post-Delivery Tests | 61 |
| | Rotating Band/Accuracy Evaluation | 63 |
| | Fuze Sensitivity Evaluation | 66 |
| | Ogive Integrity Softcatch Evaluation | 67 |
| | Body Assembly Integrity Softcatch Evaluation | 70 |
| | 500-Meter Function Demonstration | 76 |
| | Performance Analysis | 77 |

TABLE OF CONTENTS (Concluded)

| Section | Title | Page |
|----------|---|------|
| V | COST TO PRODUCE | 79 |
| VI | CONCLUSIONS AND RECOMMENDATIONS | 80 |
| | Conclusions | 80 |
| | Recommendations | 83 |
| Appendix | | |
| A | FINAL HAZARD ANALYSIS REPORT | 87 |
| B | SELECTED CARTRIDGE, PROJECTILE, FUZE AND FLASH X-RAY PHOTOGRAPHS | 103 |

LIST OF FIGURES

| Figure | Title | Page |
|--------|--|------|
| 1 | XM714A3 Delay Function Fuze, Mods IV through XIII | 2 |
| 2 | Test Vehicle Projectile with XM714A3 Fuze Attached | 3 |
| 3 | Test Vehicle Cartridge Assembly | 12 |
| 4 | Fuze Commonality | 14 |
| 5 | Fuze Operational Modes | 15 |
| 6 | XM714A3 Delay Function Fuze, Mods I, II, III and XIV | 28 |
| 7 | Test Setup - Delay Function Gun Tests | 34 |
| 8 | Projectile Body Strength Test Locations | 38 |
| 9 | Detonator Sensitivity Test Details | 39 |
| 10 | Ogive Salvage Analysis Test Setup | 41 |
| 11 | Annealed Crushwasher Force Test Results | 42 |
| 12 | ADTC Delay Function Fuze Test Results - Impact Velocity = 2500 ft/s | 58 |
| 13 | ADTC Delay Function Fuze Test Results - Impact Velocity = 3000 ft/s | 59 |
| 14 | ADTC Delay Function Fuze Test Results - Impact Velocity = 3500 ft/s | 60 |
| 15 | Inflight Photographs of Polarylene-Banded Projectile Assembly (Shot No. 795) after Exposure to 28-day Temperature and Humidity (Test 105 of Mil-Std 331) | 65 |
| 16 | Softcatch Test Setup at Hopkins Indoor Range | 71 |
| 17 | Effect of Upper Body Deformation on Friction. | 74 |
| 18 | Calculated Fuze Mod IV Sensitivity | 75 |
| 19 | 500-meter Function Demonstration Test Setup | 76 |

LIST OF TABLES

| Table | Title | Page |
|-------|--|------|
| 1 | Fuze and Projectile Assembly Characteristics | 20 |
| 2 | Comparison and Analysis of Ogive Materials | 22 |
| 3 | Original Test Plan. | 26 |
| 4 | Fuze/Projectile Structural Integrity after Impact Tests . . . | 29 |
| 5 | NM714A3 Softcatch Test Results | 32 |
| 6 | NM714A3 Early Tests and Results | 35 |
| 7 | Projectile Body Strength Test Results | 38 |
| 8 | Ogive Salvage Analysis Results | 41 |
| 9 | Effect of Plastic Banding Operations on Projectile Body Hardness. | 43 |
| 10 | NM714A3 Final Tests and Results | 45 |
| 11 | NM714A3 Supplemental Tests and Results | 49 |
| 12 | NM714A3 Requirements versus Performance | 52 |
| 13 | Ballistic Predictions for Lightweight 20mm Test Projectile | 62 |
| 14 | Test Projectile Band Retention and Accuracy | 64 |
| 15 | Fuze Damage after 3500-ft/s, 0-degree Obliquity Impacts against 0.125-inch 2024-T3 Aluminum Plate | 69 |
| 16 | LAT and Post-Delivery Test Summary | 82 |
| 17 | Recommended Fuze Design Changes | 85 |

SECTION I
INTRODUCTION

This final report covers development of the XM714A3 delay function fuze and test vehicle 20mm HEI projectile for air-to-air combat under U. S. Air Force Contract F08635-76-C-0139. The XM714A3 Mod XI final baseline fuze (Figure 1) contains the standard XM714A2 superquick fuze pad, lead cup assembly, body and spring assembly, and piston assembly. Special parts for XM714A3 delay function include seal, base, base slide, crushwasher, nylon ball, and ogive. The test vehicle projectile with the baseline XM714A3 fuze attached is shown in Figure 2.

During projectile setback and spinup in the barrel, the body and spring assembly and piston assembly setback and flatten the crushwasher. The nylon ball holds the body assembly aft, and the spring forces the piston assembly forward during initial flight over a finite time delay. When the piston assembly is forward, the rotor (contained within the body assembly) arms in the same manner as the standard XM714A2 fuze. Function delay on target impact is provided by the inertial response of the body and spring assembly which (together with crushwasher and base slide) moves toward the piston assembly (and firing pin) at an initial relative velocity equal to the velocity change of the projectile caused by target perforation.

The key objectives of this program were:

- Demonstrate nominal function delay of 9 inches (18 inches, maximum) at 0- to 80-degree obliquity, 2500- to 3500-ft/s impact velocity against 0.06- to 0.09-inch (0.06- to 0.125-inch, desired) 2024-T3 aluminum targets.
- Package fuze within 1.2-inch-long ogive profile.

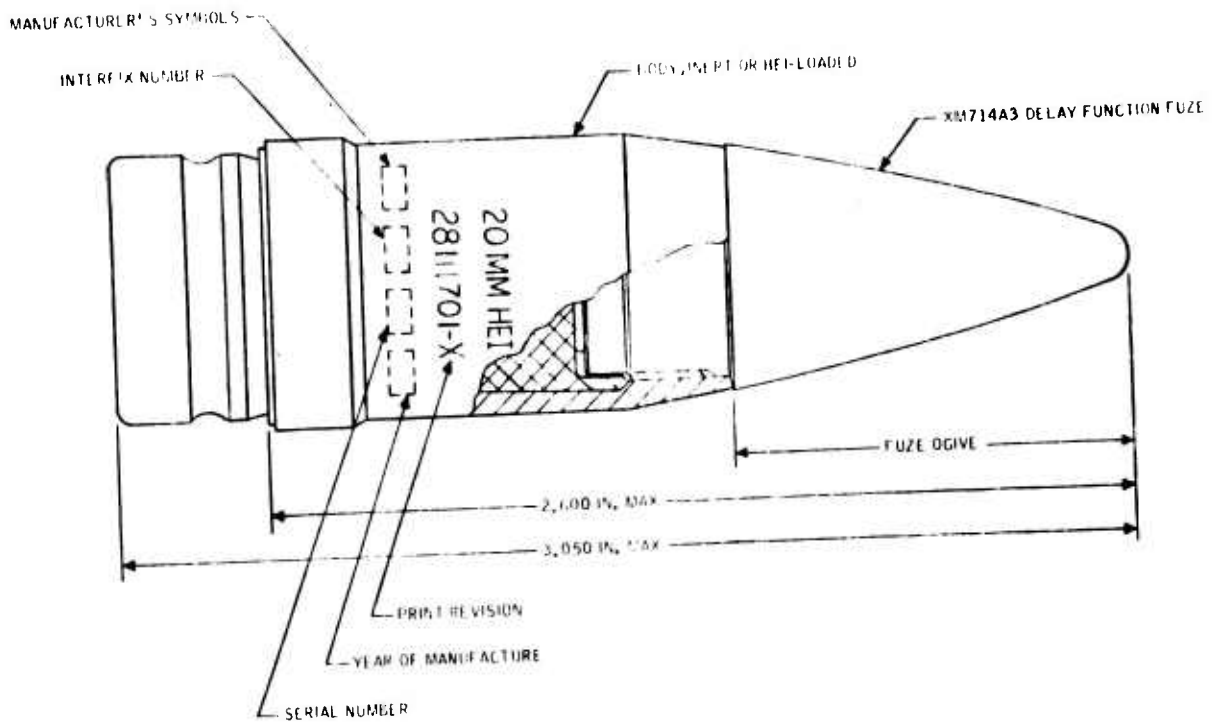

Figure 2. Test Vehicle Projectile with XM714A3 Fuze Attached

- Provide bore safety and reliable arming within 100 feet (5-meter no arm/50-meter all arm desired during follow-on engineering development).
- Demonstrate selected MIL-STD-331/MIL-STD-810B safety.
- Demonstrate no self-destruct and no function on impact with simulated rain (0.0159-inch aluminum).
- Provide projectile design with following characteristics:
 - Length: 3.05 to 3.40 inches
 - Protrusion from case: 2.600 inches, maximum
 - Weight: 1200 to 1300 grains
 - C/M: 0.30 minimum
- Test 175 rounds, minimum
- Provide documentation per DD Form 1423.
- Deliver 500 fuzed projectiles by 6 May 1976.

SECTION II SUMMARY

This XM714A3 delay function fuze/test vehicle 20mm HEI projectile advanced development program for the U.S. Air Force was begun on 21 November 1975, and 500 fuzed projectiles were shipped on 14 May 1976. The first design review meeting was held on 10-11 December at which requirements, design approach, analysis, test plan and program plan were discussed and approved. Certain technical risks were identified as follows:

- Ogive structural integrity during impact
- Projectile structural integrity during impact
- Projectile body structural integrity during HEI loading
- Fuze sensitivity against thin aluminum targets

These risks were evaluated during an early test series in January which included: (1) gun firing against the most severe required impact condition (3500 ft/s against 0.090-inch 2024-T3 aluminum at 80-degree obliquity) followed by softcatch and examination, (2) delay function demonstration against the specified target impact matrix, and (3) projectile body loading tests at twice the required loading pressure.

A final WII-STD-331 safety and gun test series was conducted in March. Although delay function performance was satisfactory, it was determined that an arming problem had developed (reliable arming demonstrated during early tests) and the contractor was authorized to correct this problem before assembling the 500-unit delivery quantity.

The arming problem was resolved during a supplemental test series. Corrective action taken was to:

- Increase firing pin-detonator clearance from 0.0695 ± 0.0185 inch to 0.0745 ± 0.0185 inch to provide sufficient clearance between the firing pin and rotor sear during the arming sequence.
- Anneal the 2024-T4 crushwasher to the 2024-0 condition to prevent washer springback after the projectile leaves the barrel.
- Provide nylon ball(s) to lock the body assembly aft and allow arming to take place; i. e., aerodynamic drag on the projectile caused the body assembly to creep forward against the piston spring during flight, causing arming failures.

A final design review meeting was held after conduct of the supplemental test series, and the XM714A3 Mod XI fuze design (Figure 1) was recommended for delivery. This was approved by Eglin Air Force Base personnel, and the following action was agreed to:

- Fabricate 20 XM714A3 Mod XI fuzed projectiles and conduct a pre-Lot Acceptance Test (LAT) evaluation.
- Obtain approval.
- Fabricate 520 XM714A3 Mod XI fuzed projectiles and conduct a 20-shot final-LAT evaluation.
- Obtain approval.
- Ship 500 fuzed projectiles on 14 May 1976.

The above actions were successful, approved, and implemented. Contractor data on this fuze configuration during pre-LAT, final-LAT and certain post-delivery tests are summarized in Table 16 and showed 87 percent delay

function on the first target and 98 percent function on either the first or second (0.090-inch aluminum) target.

A total of 307 gun tests (267 live plus 40 inert) was conducted by ADTC Eglin AFB on the above defined deliverables. The contractor was invited to witness these tests and was given access to the raw test data. These data indicated (1) adequate projectile and fuze structural integrity following the most severe required impact conditions and (2) reliable first-target delay function over the major portion of both the required and desired velocity-impact spectrum. When first-target delay function was not obtained, a second-target function was obtained on all but the desired heavy target (0.125-inch aluminum) at low angles of obliquity and high (3500 ft/s) velocity.

Eglin AFB authorized the contractor to conduct analysis and certain post-delivery tests to identify the causes of the Marginal First Target Function/Reliable Second Target Impact Function and High Failure Rate Area portions on the 3500-ft/s impact velocity performance curves (see Figure 14). This was completed on 4 August. The cause of the High Failure Rate Area was partial ogive deformation or swaging action which reduced piston and body bore diameters, thus locking the body assembly in the aft position. Strengthening the ogive by heat treatment and/or increasing wall thickness will correct this condition. The sensitivity problem (Reliable Second Target Impact Function) was caused by added friction resulting from upper body deformation due to lockweight centrifugal force. This can be corrected by increasing upper body wall thickness and reducing lockweight assembly mass (centrifugal force). Questions were also raised as to whether or not the 3500-ft/s impact condition occurs during air-to-air combat.

Post-delivery tests also verified projectile accuracy (standard deviation of radius = 0.81 mil at a 1707-inch range), polyarylene rotating band retention after 28-day T&H exposure, and long (500-meter) range delay function against 0.125-inch 2024-T3 aluminum at a high (3700-ft/s) muzzle velocity launch condition (17 for 17 delay functions).

A high-volume cost-to-produce study was completed and submitted on 16 July 1976. Costs projected below are based on a unit product cost of \$0.899 for 12 million units (1975 dollars) and an 82 percent learning curve.

| <u>Quantity (millions)</u> | <u>Cumulative Quantity (millions)</u> | <u>Unit Cost (dollars)</u> |
|--------------------------------|---|--------------------------------|
| 12.0 | 34.4 | 0.899 |
| 25.0 | 61.4 | 0.770 |
| 25.0 | 86.4 | 0.683 |
| 25.0 | 111.4 | 0.628 |
| 25.0 | 136.4 | 0.589 |
| 25.0 | 161.4 | 0.558 |
| 25.0 | 186.4 | 0.534 |
| 25.0 | 211.4 | 0.514 |

SECTION III
DESIGN ANALYSIS

REQUIREMENTS

An abbreviated summary of technical requirements is as follows:

- Incorporate a delay function in the XM714 fuze to permit the projectile to completely penetrate the aircraft skin prior to detonation.
- The fuze shall be compatible with the 20mm M61 Mann barrel gun environment.
- The fuzes shall be delivered with physically and functionally compatible test vehicle projectiles.
- Mann barrel test firings of 175 rounds minimum are required before delivery.
- The tests shall demonstrate fuze survivability, sensitivity, delay function time, MIL-STD-safety, and reliable arming.
- Fuze ogive length shall be no longer than 1.2 inches.
- The fuze shall function after complete projectile target perforation under the following conditions:

| | |
|-----------------------------|---------------------|
| Target Material: | 2024-T3 aluminum |
| Target Thickness (req'd): | 0.060 to 0.090 inch |
| Target Thickness (desired): | 0.060 to 0.125 inch |
| Impact Velocity: | 2500 to 3500 ft/s |
| Obliquity: | 0 to 80 degrees |

- The fuze shall be capable of functioning against 0.040-inch 2024-T3 aluminum at 0-degree obliquity and a velocity of 1000 ± 100 ft/s.
- The fuze shall function on fuze breakup.
- Maximum travel time between projectile penetration and fuze function shall be 0.6 millisecond (18 inches) under the above listed conditions. The nominal delay shall be 0.3 millisecond (9 inches), and variance about the nominal shall be minimized.

- The fuze is not required to function after projectile ricochet.
- The fuze shall not contain any self-destruct mechanisms.
- The fuze shall not function against 0.0159-inch 2024-T3 aluminum plate at 0-degree obliquity (simulated rain).
- The delivered fuze shall be bore safe and shall arm within 100 feet from the gun muzzle (arming range of tactical fuze design of 5 to 50 meters desired).
- The fuze shall be safe to handle and functional when delivered to the sponsor.
- The ammunition shall meet requirements of:
 - MIL-STD-331, Test 101, Jolt
 - MIL-STD-331, Test 102, Jumble
 - MIL-STD-331, Test 111, Five-Foot Drop
 - MIL-STD-331, Test 115, Static Detonator Safety
 - MIL-STD-331, Test 108, Waterproofness
 - MIL-STD-810B, Method 509, Salt Fog
 - MIL-STD-810B, Method 514.1 Vibration, Procedure II, Part 3, Curve AF
 - MIL-STD-810B, Method 518, Temperature-Humidity-Altitude
- The final fuze reliability goal shall be 0.999.
- The projectile shall be 3.05 to 3.40 inches long. The distance from behind the rotating band (top of case neck) to the tip of the fuze shall not exceed 2.600 inches.
- The test vehicle projectile and fuze assembly shall have a nominal weight goal between 1200 and 1300 grains with a ± 30 -grain tolerance about the nominal.

- The ratio of explosive charge weight to shell body weight shall be maximized, with a goal of 0.30 minimum excluding the fuze.

DESIGN APPROACH

Description

The final baseline XM714A3 Mod XI fuze and test vehicle projectile with fuze attached delivered under the contract are shown in Figures 1 and 2. The test vehicle cartridge with recommended propellant loads for velocities of interest is shown in Figure 3.

The XM714A3 delay function fuze is a modification of the standard XM714A2 fuze currently scheduled to replace the M505A3 fuze on the 20mm M56 HEI projectile and provide fuzing for the 25mm Bushmaster HEI round. The XM714A3 fuze uses many of the same internal components as the Army-developed XM714A2. The XM714A2 is a double-acting fuze. It has a nose probe for superquick point impact function and a movable detonator housing that provides a delay function as it carries the detonator to the firing pin in graze or self-destruct modes. In the XM714A3 fuze, the superquick probe is eliminated, and the entire fuze function is dependent upon the inertial delay action of the movable detonator assembly. The key fuze signature is the velocity loss (ΔV) of the projectile as it penetrates or ricochets from typical aircraft skin thicknesses. Specific changes to the XM714A2 include:

- Replacing the setback spring with a crushwasher.
- Replacing the two steel self-destruct balls with one glass-filled nylon ball.
- Eliminating the superquick (SQ) probe assembly (three parts) from the ogive.

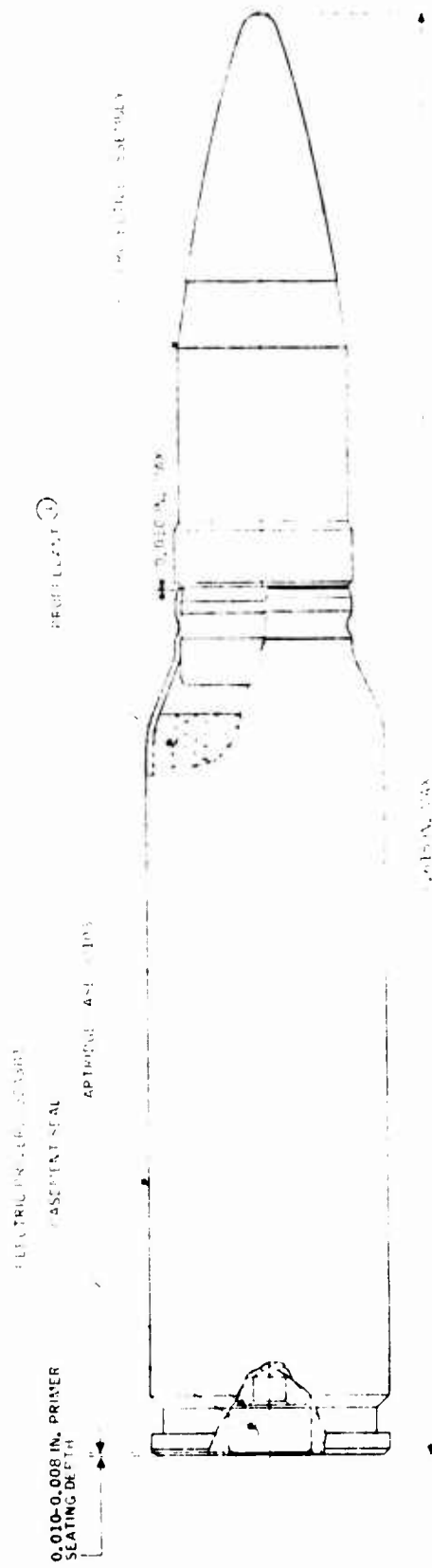

(C) ELECTRIC PROPELLANT CHARGE AND APRIME ASSEMBLY
 A STANDARD 5/8" DIA. (1.601) DIA. CARTRIDGE
 2.5" LONG

| PRIMER VELOCITY (FT. S.) | PROPELLANT TYPE | ADV. SRY. PROPELLANT CHARGE WEIGHT (GRAMS) | INITIAL PRESSURE (PSI) | TIME TO BURN (SEC.) |
|--------------------------------|---------------------|---|------------------------------|------------------------------|
| 3000 | ULIN V-070 | 41.7 | 1000 | 2.0 |
| 3500 | ULIN V-070 | 36.0 | 1000 | 2.0 |
| 5000 | ULIN V-070 BALLS | 31.0 | 1000 | 2.0 |
| 2500 | ULIN V-070 BALLS | 25.0 | 1000 | 2.0 |
| 1000 | ULIN V-070 BALLS | 7.0 | 1000 | 2.0 |

NOTE: PROPELLANT - PRODUCT OF HEGGON POWER CO., INC.
 SHAWNEE MISSION, KANSAS.
 V-070 20mm BALL PROPELLANT - PRODUCT OF ULIN CORP.
 EAST ALTON, ILL.

Figure 3. Test Vehicle Cartridge Assembly

- Adding a base slide to increase fuze sensitivity by increasing body assembly effective mass.
- Redesigning the ogive to provide increased strength by increasing thread size from 9/16-32 to 5/8-32. The base is threaded onto the ogive to improve fuze strength to better withstand the high setback (gun), and target impact loads associated with the lighter projectile.

To illustrate the degree of similarity to the XM714A2, both fuzes are diagrammed in Figure 4. The shaded areas show the commonality.

Operation

The XM714A3 delay function fuze is shown in its safe, setback, armed, and detonation operational modes in Figure 5. The fuze is subjected to high spin and acceleration as the projectile travels down the barrel. These forces cause both the piston assembly and body assembly to setback, permanently deforming the crushwasher. Air originally in the bottom of the fuze is displaced through ports into the chamber above the piston. High spin forces occur almost simultaneously with the setback force, causing the centrifugal lockweights to move against their springs. This removes one constraint on the rotor in the safe position. Centrifugal force also causes the rubber piston seal to spin out against the inner bore of the ogive to provide the necessary sealing of air.

As the projectile exits the muzzle, the acceleration force dissipates, and the piston is free to move forward under forces exerted by the piston spring. A finite time that can be controlled is required for the piston to move forward fully since air must move through the porous metal restrictor. This action provides an arming delay of 5 to 50 meters over a temperature range from -60° to +155°F in the 20mm projectile environment.

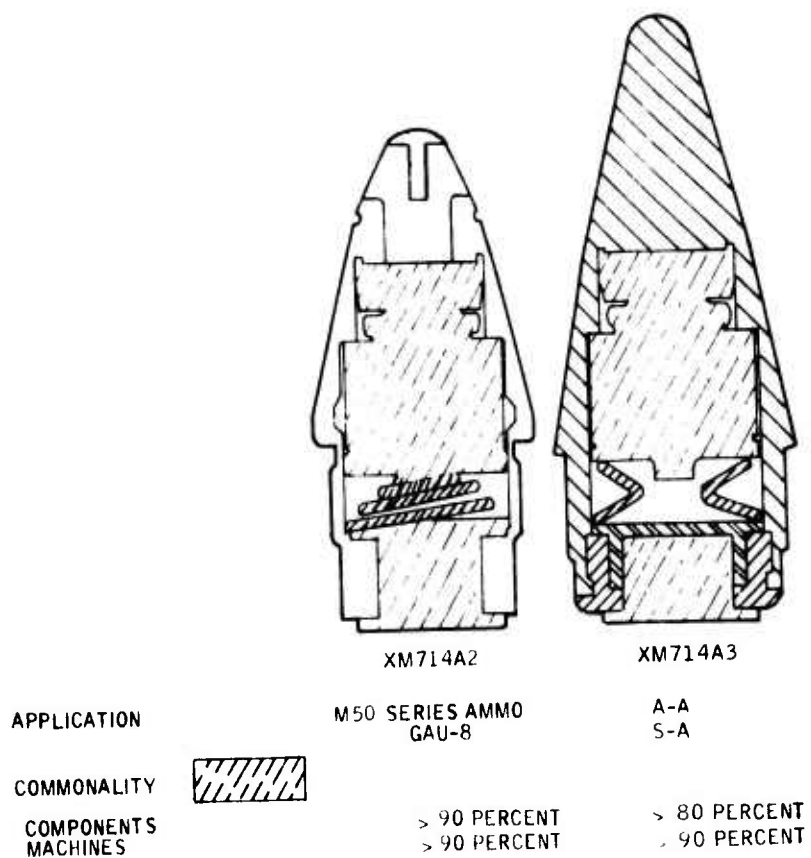
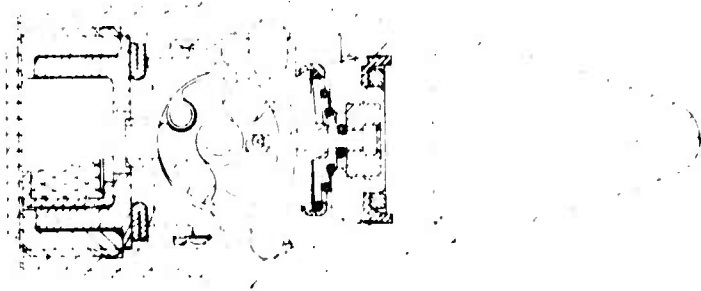

Figure 4. Fuze Commonality

SAFE



SETBACK



ARMED

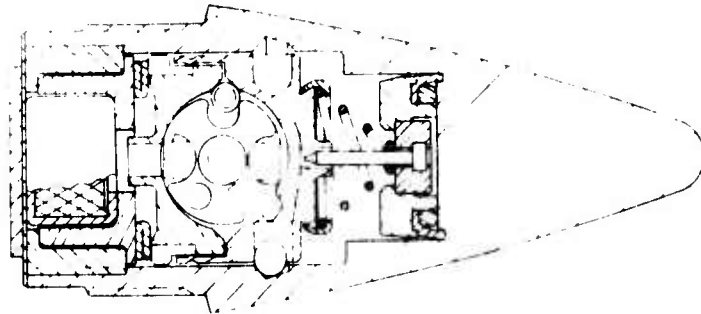

DETONATION



Figure 5. Fuze Operational Modes

When the piston reaches the forward position, the firing pin withdraws from the rotor and allows it to rotate to the armed position. Centrifugal force acting on the roller weight causes it to move into a groove and lock the rotor in the armed position. The fuze is fully armed when the detonator is in line with the firing pin and the lead assembly.

Detonation (see bottom view of Figure 5) occurs when the armed fuze encounters the following:

- Delay Function on Soft (Aluminum) Targets -- Impact and perforation of aircraft targets causes projectile deceleration and a velocity change (ΔV). This velocity change causes the body assembly to move forward toward the piston assembly at an initial velocity (with respect to the ogive) equal to ΔV . This causes the detonator to impinge the firing pin attached to the piston assembly. The detonator functions, initiating the lead assembly and main charge. Function delay results from the summation of the inertial triggering time and detonator initiation time.
- Superquick Function on Hard Targets -- Impact against hard targets causes the ogive to crush, driving the piston assembly, with firing pin attached, to the rear. This causes superquick initiation of the detonator and explosive train. This target discriminating feature assures that function on hard targets is not defeated by projectile ogive structural failure.
- Graze Function -- During graze impact, the projectile experiences forces perpendicular to the spin axis as well as deceleration forces along its axis. The ogive digs into the target, and the resultant axial deceleration and ΔV triggers the fuze as described above under Delay Function.

- Trajectory Safety and Long Range Function -- If no target is encountered within the anticipated tactical range, no function will occur until the projectile flight is terminated. Restrained by the ball and piston spring, the body assembly will not impinge the detonator until the projectile hits the ground or some other media.
- Secondary Impact Function -- Should the projectile impact a very soft portion of the target, such as 0.020- to 0.040-inch aluminum, the fuze would still function internally to the aircraft due to secondary impacts with fuel cells, fuel, inside walls, stringers, etc.

TECHNICAL RISKS

The technical risk areas in meeting the stated requirements were identified so that analysis and evaluation activity could be focused on these areas during the program. Risk areas were identified as follows at the beginning of the program:

- Ogive Structural Integrity During Impact -- The proposed technical approach included selection of a conservative, heat-treatable, high-strength stainless steel alloy (17-4PH, Condition H925) and evaluating this material using ogives of three wall thicknesses, (0.03, 0.04, and 0.05 inch) during early tests. An alternate material (carbon steel, hardening grade, AISI Type C1144) was also successfully evaluated and incorporated to reduce high-volume unit cost.
- Projectile Structural Integrity During Impact -- The proposed test vehicle projectile was successfully evaluated during early tests.
- Projectile Body Structural Integrity During HEI Loading -- Projectile body wall strength during 30,000-psi LCA 1 loading operations was demonstrated with a factor of safety of 2.0 (60,000 psi) during early tests.

- Fuze Sensitivity Against Thin Aluminum Targets -- High-velocity (3500-ft/s) impacts at 0-degree obliquity against thin (0.063-inch) 2024-T3 aluminum targets produced sensitivity failures. This can be corrected by increasing body assembly (or slider) mass or replacing the crushwasher with a setback spring.

DELAY FUNCTION ANALYSIS

During the program, the XM714A3 delay function sensitivity was continually monitored, and computer math models were updated so sensitivity could be predicted and understood. A program called "PROJDV" was used to determine the change in projectile velocity (ΔV) produced by target impacts at 0-degree obliquity. This program was based on 20mm M55 projectile firings against 0.020- to 0.125-inch 2024-T3 aluminum targets and computes projectile ΔV as a function of target thickness, projectile initial impact velocity, target density, projectile diameter, projectile weight, and target shear strength. Various computer programs for fuze function sensitivity were developed as follows:

- DELAY - For crushwasher-equipped fuzes with no balls
- DAWDLE - Same as above except piston rebound motion included
- FUNDEL - For setback-spring-equipped fuzes with balls

These programs print out firing pin energy, delay time, and delay distance as a function of firing pin-detonator clearance. A sample output of FUNDEL is presented in Figure 18. The above fuze sensitivity programs show good correlation with observed experimental data.

ARMING DELAY ANALYSIS

The contractor is confident that an arming delay of 5 to 50 meters can be designed into the XM714A3 fuze during follow-on engineering development. Since the objective of this feasibility program was to demonstrate and deliver 500 delay-function-fuzed projectiles, it was agreed that the fuze be bore safe and arm within 100 feet of the gun muzzle. This was accomplished by removing the rubber piston seal from the piston assembly which allowed air to move around the piston assembly during arming.

PHYSICAL PARAMETERS

Fuze and projectile physical and lethality parameters are presented in Table 1. These characteristics are for the deliverable items, i. e., XM714A3 Mod XI-fuzed projectile. The function delay changed from 7.5 ± 2.5 inches to 10 ± 4 inches when nylon balls were added (i. e., firing pin-detonator clearance increased).

OGIVE MATERIAL STUDY

A study of alternate materials for the ogive was conducted.

The objectives of this study were (1) to determine if 17-4PH stainless steel would lend itself to follow-on engineering development and high-volume production and (2) to consider other candidate ogive materials. The following materials were considered in this study:

| | |
|-------|--------------------------------|
| C1117 | Carbon steel/carborizing grade |
| C1118 | Carbon steel/carborizing grade |
| C1144 | Carbon steel/hardening grade |

TABLE 1. FUZE AND PROJECTILE ASSEMBLY CHARACTERISTICS

| Fuze | |
|--------------------------|----------------------------|
| Weight | 456 grains |
| CG (shoulder) | 0.193 inch |
| Polar Moment | 0.00316 lb-in ² |
| Trans. Moment | 0.01258 lb-in ² |
| Projectile Assembly | |
| <u>Lethality:</u> | |
| ● Function Delay | 10 ±4 inches |
| ● HEI Mix | 193 grains |
| ● C/M | 0.342 |
| <u>Weight Breakdown:</u> | |
| ● Fuze | 456 grains |
| ● Body | 564 grains |
| ● Band | 13 grains |
| ● HEI Mix | 193 grains |
| - Total | 1226 grains |
| <u>Other:</u> | |
| ● CG (base) | 1.25 inches |
| ● Length | 3.05 inches |
| ● Protrusion | 2.60 inches |
| ● Polar Moment | 0.014 lb-in ² |
| ● Trans. Moment | 0.109 lb-in ² |

| | |
|-------------|--|
| B1212/B1213 | Free-cutting carbon steel |
| 4130 | Low-alloy steel |
| 4130L | Low-alloy steel/lead for machinability |
| 17-4PH | Age-hardening stainless steel/Condition A |
| 17-4PH | Age-hardening stainless steel/Condition H925 |
| 303/303 Se | Austenitic stainless steel |
| 416/416 Sc | Martensitic stainless steel (best machinability for stainless) |

These materials are compared on the basis of cost, machinability, strength, availability, and other factors in Table 2. At the bottom of Table 2, each material is given an overall statistical rating by assuming cost, machinability, and strength are of equal importance (30 percent each) and availability of 10 percent importance. An ideal material would have an overall rating of 100 percent ($30 + 30 + 30 + 10 = 100$). These percentages were multiplied by a conformance factor which was defined as follows for each parameter:

Material cost factor = (cost of C1144) \div (cost of material)

Machinability factor = (machinability) \div 100

Strength factor = (tensile strength of material) \div (tensile strength of
17-4PH Condition H925)

Availability factor = 1.0, if stocked, and 0, if not stocked

Hardening-grade carbon steel AISI C1144 received the highest statistical rating at 86 percent. It was selected as an alternate ogive material because of its low cost, good machinability, reasonably high strength, and availability. Also, the contractor has considerable experience with this material as it is currently used for making XM714A2 ogives and GAU-8/A TP (target practice) projectile bodies. During high-volume production, an eddy current check may have to be specified to detect cracks. This, however, would be required with all of the low-carbon steels considered (C1117, C1118, C1144, and B1212/B1213).

TABLE 2. COMPARISON AND ANALYSIS OF OGIVE MATERIALS

| Parameter | Material | | | | | | | | | |
|------------------------------------|--|-------------|---------|-----------------|---------|------------------|--------------------|-----------------------|--------------|-------------------|
| | C1117 | C1118 | C1144 | B1212/ B1213 | 4130 | 4130L | 17-4PH (Cond A) | 17-4PH (Cond H925) | 303/ 303S | 416/ 416Sc |
| Material Cost (\$/lb) ^a | 0.2085 | 0.2080 | 0.2060 | 0.2140 | 0.3510 | 0.3885 | 1.29 | 1.29 | 1.49 | 1.01 |
| Weight Required per Ogive | 0.219 pound based on 0.750-inch-diameter x 1.750-inch-long stock | | | | | | | | | |
| Material Cost per Ogive (\$) | 0.0457 | 0.0456 | 0.0451 | 0.0469 | 0.0769 | 0.0851 | 0.2825 | 0.2825 | 0.3263 | 0.2212 |
| Machinability (B1112 = 100%) | 90 | 90 | 85 | 100/125 | 60 | > 60 (70 est) | 40 est | 40 est | 65 | 80 |
| Tensile Strength (kpsi) | 97 | 113 | 128-97 | 80-105 | 234-98 | NA | 156 | 190 | 90-110 | 90- (75) 190 |
| Yield Point (kpsi) | 59 | 77 | 91-68 | 70-90 | 197-89 | NA | 110 | 175 | 35-75 | 60- (40) 145 |
| Percent Elongation (2 inches) | 23 | 17 | 17-24 | 12-22 | 12-28 | NA | 7 | 10 | 50-30 | 12- (30) 25 |
| Impact Strength (Izod ft-lb) | 33 | 16 | 7-62 | Low | 32-108 | NA | High | High | 80 | (70) 70 |
| Availability in Dev. Quantities | OK | Not stocked | OK | B1213 OK | OK | Not stocked | OK | OK | OK | OK |
| Corrosion Resistance | Poor | Poor | Poor | Poor | Poor | Poor | Good | Good | Good | Good |
| Metal Finish Required | Zinc | Zinc | Zinc | Zinc | Zinc | Zinc | Passivate | Passivate | Passivate | Passivate |
| Hardness: | 192 | 229 | 277-301 | 163-229 | 461-202 | NA | C35 | C43 | 150-240 | (155) 180- 300 |
| Heat Treat Required | No | No | Yes | No | Yes | Yes | No | Yes | ? | ? |

| Parameter | Material Performance Rating | |
|---------------|-------------------------------|----------|
| | Relative Importance (percent) | Value |
| Material Cost | 30 | x0.30=30 |
| Machinability | 30 | x0.30=27 |
| Strength | 30 | x0.30=18 |
| Availability | 10 | x1=10 |
| Total | 100 | 82 |

^a Based on >40,000-pound purchase.

A small quantity of C1144 ogives having 0.04- and 0.05-inch wall thickness were fabricated for early testing with the baseline 17-4PH stainless steel ogives, and comparisons were made. Early test results are presented in Section IV.

STRESS ANALYSIS

The test vehicle projectile body was analyzed for stress during gun launch. This analysis was based on a computer program which has been verified by extensive test firings of thin-walled 4130 steel projectile bodies. Allowable dynamic stress loads between 2-1/2 and 3 times the static tensile strength have been verified by test. This means that 4130 steel, heat treated to RC37-42 (S tensile = 166 to 194 kpsi), would have dynamic tensile strengths above 415 kpsi. Projectile body stress calculations are below this level as shown for 60-kpsi propellant peak pressure:

| | | |
|--|---|---|
| Stress (projectile base) = SR12 = 272 kpsi | } | No permanent deformation observed during gun launch/softcatch tests |
| Stress (aft of band) = SRA = 392 kpsi | | |
| Stress (forward of band) = SRF = 322 kpsi | | |
| Stress (fuze junction) = SRC = 101 kpsi | | |

Stress levels were calculated on the thinnest projectile body wall section during 30-kpsi explosive loading operations assuming a uniform thickwall cylindrical section with results as follows:

$$(S_t)_{\text{inside}} = (30000) \frac{(0.3915)^2 + (0.334)^2}{(0.3915)^2 - (0.334)^2} = 190 \text{ kpsi}$$

$$(S_t)_{\text{outside}} = 2(30000) \frac{(0.334)^2}{(0.3915)^2 - (0.334)^2} = 160 \text{ kpsi}$$

Actual stress levels are considerably below these values because sections aft and forward of the thinnest body wall section are thicker. This was later verified during early tests; i. e., no permanent deformation occurred during explosive loading operations at twice (60 kpsi) the pressure.

HAZARD ANALYSIS

A hazard analysis for the XM714A3 fuze was performed which included the following tasks:

- Review of XM714A3 safety features against the requirements of MIL-STD-1316A, Criteria for Fuze Design Safety.
- Revision of safety fault tree diagrams on the XM714 fuze to reflect the XM714A3 changes.
- Investigation of XM714 fuze safety aspects that could be affected by changes planned for the delay version, XM714A3.

A detailed final report on this analysis is included as Appendix A. The general conclusion of this report is that the XM714A3 delay fuze meets all of the fuze design safety criteria appropriate to the intended application.

SECTION IV
FUZE EVALUATION

PLANNED VERSUS ACTUAL TESTS

The contractor's original approved test plan is shown in Table 3. It called for 230 tests. Planned quantities are compared with actual test quantities below:

| | <u>Planned</u> | <u>Actual</u> |
|-------------------------|----------------|---------------|
| Early Tests | 80 | 79 |
| Final Tests | 120 | 120 |
| Supplemental Tests | 0 | 44 |
| Pre-LAT | 0 | 20 |
| Final-LAT | 30 | 20 |
| Post-Delivery Tests | 0 | 90 |
| Subtotal | <u>230</u> | <u>373</u> |
| Miscellaneous Lab Tests | <u>0</u> | <u>51</u> |
| Total | 230 | 424 |

EARLY TESTS

Early tests included 37 structural impact gun tests and 42 all-up round delay function gun tests (37 + 42 = 79 as shown above). The 51 miscellaneous laboratory tests conducted during the program are also discussed in this section.

TABLE 3. ORIGINAL TEST PLAN

| Test Group Identification / Task Item Reference | Test Description Objectives | No. of Tests | Test Conditions | | | Data Requirements (Preliminary) | | | | | | | | | |
|---|--|-----------------------|--|-----------------|--------------------------------------|--------------------------------------|-----------------------|-----------------------|-----------------------|-----------------------|-----------------------|-----------------------|-----------------------|---|---|
| | | | General | Fuze Type | Impact Velocity (ft/s) | Aluminum Target Thickness (in.) | Obliquity (deg) | Muzzle Velocity | Fuze Function | High Order Detonation | Function Delay | Navy Coverage | Comments | | |
| A/0001 | Define thin wall lightweight ogive with sufficient structural strength to allow fuze function. Verify functional integrity of rotating band. Evaluate two ogive materials. | 15 13 | Fire through target, soft catch and examine inert fuze function (three variations anticipated). | Early Alternats | 3500 | 0.09 | 80 | X | X | | | | | | 17-4PH Ogive All Material Ogive |
| B/0002 | Verify improved in-service design through evaluation of ballistic, structural, and vibration structure. | 0 | Monitor external ballistics, soft catch for rotating band examination, and fire through target for structural examination (three variations anticipated). | | 3500 | 0.09 | 80 | X | | | | | | | Projectile Performance in Other Tests |
| C ₁ (Preliminary)/0002 | Determine effect of fuze parameters on function delay. | 20 | Fire through target and monitor function distance. Determine effect of critical fuze parts on delay time. Test at 100 ft range. | Early | 2500 3500 | 0.06/0.03 0.06/0.09 | 0/80 0/80 | X X | X X | X X | X X | X X | X X | X X | To maintain Rear Sensitivity (Test F) - 5 Units |
| C ₂ (Final)/0002 | Demonstrate delay function of final fuze design. | 20 20 | Demonstrate delay function of final fuze design. Test at 100 ft range. | Final | 2500 3500 | 0.06/0.09 0.06/0.09 | 0/80 0/80 | X X | X X | X X | X X | X X | X X | X X | |
| D/0002 | Verify fuze survivability at 80 degree obliquity - heavy target. | 0 5 | Fire at heavy target. | | 3500 | 0.125 | 80/0 | X | X | X | X | X | X | X | |
| E ₁ (Preliminary)/0002 | Produce fuze function on 0.04 in. thick aluminum target. | 0 | Down load to muzzle velocity of 1000 ft/s. | | 1000 | 0.04 | 0/80 | X | X | X | X | X | X | X | |
| E ₂ (Final)/0002 | Demonstrate fuze function on 0.04 in thick aluminum target. | 5 | Demonstrate fuze function on 0.04 in thick aluminum target. | | 1000 | 0.04 | 0 | X | X | X | X | X | X | X | |
| F/0002 | Demonstrate superquick function on hard target and no function on rain simulation target. | 0 | Hard target impact. | | 3500 | Steel (0.23) | 0/80 | X | X | X | X | X | X | X | |
| G ₁ (Preliminary)/0002 | Verify 5-meter no-arm/50-meter all-arm points. | 0 | Rain simulation target impact. | | 3500 | 0.016 | 0 | X | X | X | X | X | X | X | |
| G ₂ (Final)/0002 | Demonstrate above. | 0 | No arm at 5 meters All arm at 50 meters | | 3500 | 0.09 | 0 | X | X | X | X | X | X | X | Demonstrate 100-ft All-Arm in Other Tests |
| H/0002 | Verify long-range function. | 0 | Fire at long range/monitor function distance or point. | | Blax. Fuzes (VEL) | --- | --- | --- | --- | --- | --- | --- | --- | --- | Contractor Funded |
| I/0002 | Verify fuze can withstand selected MIL-STD-333 and MIL-STD-810H tests. | 5 5 5 5 5 | MIL-STD-331 test 101 jolt MIL-STD-331 test 102 jolt MIL-STD-331 test 111 5 ft. drop MIL-STD-331 test 115 OLS MIL-STD-331 test 108 water proofness MIL-STD-810H Method 809 salt fog MIL-STD-810H Method 514.1 vibration MIL-STD-810H Method 518 Temp/Humidity/Alt (Modified) | Final | 3500 3500 3500 3500 3500 | 0.09 0.09 0.09 0.09 0.09 | 0 0 0 0 0 | X X X X X | X X X X X | X X X X X | X X X X X | X X X X X | X X X X X | Inspection function Inspection Inspection | |
| K/0001 and 0002 | Contingency -- as required to supplement or re-evaluate any of above test groups. | 40 | --- | Early and Final | --- | --- | --- | --- | --- | --- | --- | --- | --- | --- | No Tests Planned |
| L/0004 | Lot acceptance test. | 15 0 15 | All arm and function - 100 ft Sensitivity and delay - 100 ft | Final | 3500 3500 | 0.09 0.09 | 0 | X X | X X | X X | X X | X X | X X | X X | |
| | | TOTAL | | | | | | | | | | | | | |

80 "EARLY" TEST UNITS (17-4PH OGIVE)
 15 "ALTERNATE" TEST UNITS (ALTERNATE MATERIAL OGIVES)
 135 "FINAL" DESIGN TEST UNITS (17-4PH OGIVE)
 230 = TOTAL

INCLUDES

Structural Integrity Gun Tests

Fuze ogive and projectile structural integrity were evaluated at the worst impact condition [defined as maximum velocity (3500 ft/s +) - maximum 2024-T3 aluminum target thickness (0.09 inch) - maximum obliquity (80 deg)] by firing 25 rounds through the target. Flash x-ray pictures were taken after target perforation followed by softcatch (polystyrene beads) recovery followed by dimensional analysis. Fuze variations were evaluated as defined in Figure 6 and Table 4. These included two ogive materials (17-4PH stainless heat treated to condition H925 and C1144 steel heat treated to Rockwell RC 22-30), three ogive wall thickness (0.03, 0.04, and 0.05 inch), and two internal arrangements (inertial and ball-release inertial). The fuzes were equipped with live detonators and inert (solid aluminum) leads so fuze function could be evaluated. The projectiles were inert filled.

The 25 cartridge cases were loaded with a 40-gram charge of Olin WC870 propellant and crimped to the projectile and fuze assemblies. The targets were placed 100 feet downrange from the gun muzzle. Gun firing data are summarized in Table 4. Conclusions were as follows:

- (1) Units were tested at velocities higher than specified (3500 ft/s) as shown below:

| <u>Fuze Ogive Wall Thickness (in)</u> | <u>Average Projectile Weight (grains)</u> | <u>Sample Size</u> | <u>Average Velocity (ft/s)</u> | <u>Range in Velocity (ft/s)</u> |
|---|---|------------------------|--|---|
| 0.03 | 1158 | 5 | 3665 | 3715-3610 = 105 |
| 0.04 | 1185 | 9 | 3635 | 3675-3570 = 105 |
| 0.05 | 1220 | 8 | 3625 | 3675-3580 = 95 |

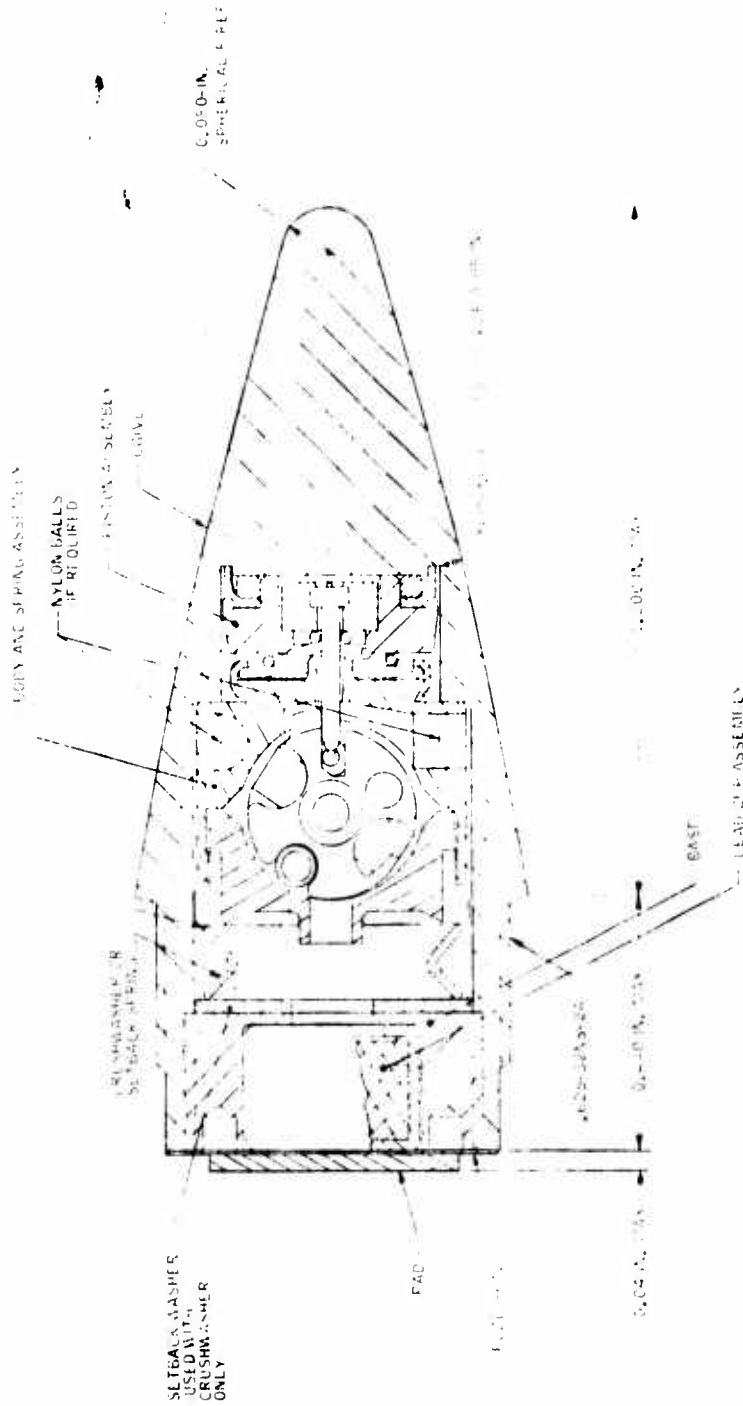

| FUZE MOD | PISTON SPRING FORCE | CRUSHWASHER | NYLON BALLS | LEAD OF P ASSEMBLY | PISTON TO CRUSHWASHER CLEARANCE | CRUSHWASHER TO PISTON CLEARANCE | CRUSHWASHER TO SCRIBER GROVE CLEARANCE | CRUSHWASHER TO BAST CLEARANCE |
|----------|---------------------|----------------|-------------|--------------------|---------------------------------|---------------------------------|--|-------------------------------|
| I | 1.50 | ORIGINAL T4 | 0 | -- | 0.0 | 0.0 | 0.0 | NO POLYURETHANE |
| II | 1.50 | SETBACK SPRING | 2 | 45 | 0.04 | 0.04 | 0.04 | NO POLYURETHANE |
| III | 1.50 | ORIGINAL T4 | 0 | -- | 0.07 | 0.07 | 0.07 | NO POLYURETHANE |
| IV | 0.55 | SETBACK SPRING | 2 | 25 | 0.0 | 0.0 | 0.0 | NO POLYURETHANE |

Figure 6. XM714A3 Delay Function Fuze, Mods I, II, III and IV

TABLE 4. FUZE/PROJECTILE STRUCTURAL INTEGRITY AFTER IMPACT TESTS

| Fuze Number | Fuze/Projectile Description | | Impact Conditions | | Fuze Attached to Projectile | Detector Functioned after Impact | Projectile Broken After Impact | Fuze Deformation | | |
|-------------|-----------------------------|------------------|-----------------------------|--------------------------|-----------------------------|----------------------------------|--------------------------------|-------------------------------|------------------------------|----------------------------------|
| | Case Wall Thickness (in) | Fuze Part Number | Fuze - Proj. Weight (grams) | Velocity at 23 ft (ft/s) | | | | 2024-T3 Target Thickness (in) | 2024-T3 Target Diameter (in) | No. of Disks Broken After Impact |
| 1 | 0.04 | 2:1116-04 | 1184 | 3500 | 0.0004 | 0.0004 | Yes | Yes | 0.4 | 0.4 |
| 2 | 0.04 | 2:1116-04 | 1187 | 3620 | 0.0004 | 0.0004 | Yes | Yes | 0.4 | 0.4 |
| 3 | 0.04 | 2:1116-04 | 1192 | 3650 | 0.0004 | 0.0004 | Yes | Yes | 0.4 | 0.4 |
| 4 | 0.04 | 2:1116-04 | 1211 | 3500 | 0.0004 | 0.0004 | No | No | 0.4 | 0.4 |
| 5 | 0.04 | 2:1116-04 | 1230 | 3600 | 0.0004 | 0.0004 | Partial | Yes | 0.4 | 0.4 |
| 6 | 0.04 | 2:1116-04 | 1225 | 3650 | 0.0004 | 0.0004 | Partial | Yes | 0.4 | 0.4 |
| 7 | 0.04 | 2:1116-04 | 1182 | 3510 | 0.0004 | 0.0004 | Broken fuze - no projectile | Yes | 0.4 | 0.4 |
| 8 | 0.04 | 2:1116-04 | 1186 | 3000 | 0.0004 | 0.0004 | Partial | Yes | 0.4 | 0.4 |
| 9 | 0.04 | 2:1116-04 | 1185 | 3650 | 0.0004 | 0.0004 | Partial | Yes | 0.4 | 0.4 |
| 10 | 0.04 | 2:1116-04 | 1176 | 3510 | 0.0004 | 0.0004 | Yes | Yes | 0.4 | 0.4 |
| 11 | 0.04 | 2:1116-04 | 1173 | 3650 | 0.0004 | 0.0004 | Partial | Yes | 0.4 | 0.4 |
| 12 | 0.04 | 2:1116-04 | 1213 | 3600 | 0.0004 | 0.0004 | Yes | Yes | 0.4 | 0.4 |
| 13 | 0.04 | 2:1116-04 | 1212 | 3650 | 0.0004 | 0.0004 | Partial | Yes | 0.4 | 0.4 |
| 14 | 0.04 | 2:1116-04 | 1177 | 3640 | 0.0004 | 0.0004 | Partial | Yes | 0.4 | 0.4 |
| 15 | 0.04 | 2:1116-04 | 1181 | 3710 | 0.0004 | 0.0004 | No | No | 0.4 | 0.4 |
| 16 | 0.04 | 2:1116-04 | 1175 | NA | 0.0004 | 0.0004 | Yes | Yes | 0.4 | 0.4 |
| 17 | 0.04 | 2:1116-04 | 1199 | 3500 | 0.0004 | 0.0004 | Yes | Yes | 0.4 | 0.4 |
| 18 | 0.04 | 2:1116-04 | 1175 | 3620 | 0.0004 | 0.0004 | Partial | No | 0.4 | 0.4 |
| 19 | 0.04 | 2:1116-04 | 1175 | 3665 | 0.0004 | 0.0004 | Partial | Yes | 0.4 | 0.4 |
| 20 | 0.04 | 2:1116-04 | 1195 | 3600 | 0.0004 | 0.0004 | No | No | 0.4 | 0.4 |
| 21 | 0.04 | 2:1116-04 | 1231 | NA | 0.0004 | 0.0004 | Yes | Yes | 0.4 | 0.4 |
| 22 | 0.04 | 2:1116-04 | 1225 | NA | 0.0004 | 0.0004 | Yes | Yes | 0.4 | 0.4 |
| 23 | 0.04 | 2:1116-04 | 1221 | 3640 | 0.0004 | 0.0004 | No | No | 0.4 | 0.4 |
| 24 | 0.04 | 2:1116-04 | 1211 | 3650 | 0.0004 | 0.0004 | Yes | Yes | 0.4 | 0.4 |
| 25 | 0.04 | 2:1116-04 | 1224 | 3600 | 0.0004 | 0.0004 | Yes | Yes | 0.4 | 0.4 |

BEST AVAILABLE COPY

- (2) Both 17-4PH and C1144 ogives with wall thickness of 0.03 and 0.04 inch failed on impact with 0.09-inch 2024-T3 aluminum targets at 80-degree obliquity; however, the detonators functioned properly into the leads on most units. The 0.05-inch-walled 17-4PH and C1144 ogives withstood 0.09-inch, 80-degree impacts. The C1144 ogive with 0.05-inch wall was selected for follow-on fabrication and delivery as it provided the best performance (see units 21-25, Table 4) and because of its low cost and excellent machinability (see Table 2).
- (3) Certain changes were made to the C1144 ogive to further increase structural integrity during impact. These changes included addition of 0.015 to 0.005 R fillets in the piston and body assembly bore and increasing the minor thread diameter.
- (4) Only one arming failure was noted in 25 shots. This appeared to be caused by deformation of the glass-filled nylon upper body during setback.

A second, 12-shot, softcatch test was conducted at high and low velocity to analyze structural integrity of internal parts because of the deformation noted in (4) above. The test plan was as follows:

| <u>Qty</u> | <u>WC870 Propellant Weight (gm)</u> | <u>Velocity (ft/s)</u> | <u>Fuze Design</u> |
|------------|---|----------------------------|---|
| 3 | 40 | 3700 | Baseline Inertial, per Figure 6 Mod I. |
| 3 | 40 | 3700 | Alternate Ball Release Stored Energy per Figure 6 (Mod II). |
| 3 | 25 | 2500 | Baseline Inertial per Figure 6 (Mod I). |
| 3 | 25 | 2500 | Alternate Ball Release Stored Energy per Figure 6 (Mod II). |

Each of the four above defined three-unit groups consisted of two fuzes with lockweights and one without lockweights. All 12 fuzes contained inert detonators and leads and were attached to HFI-filled projectiles. The units were fired into a polystyrene-bead-filled catcher placed 100 feet downrange from the gun muzzle. Projectile velocity was determined using coils placed 18 and 28 feet downrange from the muzzle. Projectile accuracy was monitored for high- and low-velocity units with results as follows:

- At 3700 ft/s: average mean radius = 1.10 mil at 100 feet
- At 2500 ft/s: average mean radius = 0.60 mil at 100 feet

These accuracy values did improve with the end item because a consistent ogive wall thickness (consistent projectile weight) was specified; i. e., wall thickness of 0.03 to 0.05 inch produced projectile weight variations of 1158 grains to 1226 grains respectively.

Fuze design, velocity at 23 feet downrange, and softcatch recovery measurements (before and after test) are given in Table 5. Conclusions were as follows:

- (1) All fuzes were fully armed at entry into catcher. This was evidenced by the firing pin imprinting the center of the inert detonator.
- (2) Crushwashers deformed properly under setback loads. Washer thickness was 0.026 inch minimum, and the outside diameter was 0.487 inch maximum. There was no difference between high- and low-velocity units.
- (3) Lower body deformation from setback loads does not prevent rotor arming or restrict body assembly movement during delay function. Imprints of the rotor and roller weight, in the out-of-line position, were evident in the lower body. Heavy imprints, 0.005- to 0.010-

TABLE 5. NM714A3 SOFTCATCH TEST RESULTS

| Date | Time | Location | Depth (m) | Species | Softcatch | | Trawl | | Dredge | | Remarks |
|------|-------|------------|-----------|----------|-----------|-------------|-------|-------------|--------|-------------|----------------|
| | | | | | Count | Weight (kg) | Count | Weight (kg) | Count | Weight (kg) | |
| 1971 | 10:00 | Station 1 | 10 | Starfish | 1 | 0.5 | 0 | 0 | 0 | 0 | Small starfish |
| 1971 | 10:15 | Station 2 | 10 | Starfish | 1 | 0.5 | 0 | 0 | 0 | 0 | Small starfish |
| 1971 | 10:30 | Station 3 | 10 | Starfish | 1 | 0.5 | 0 | 0 | 0 | 0 | Small starfish |
| 1971 | 10:45 | Station 4 | 10 | Starfish | 1 | 0.5 | 0 | 0 | 0 | 0 | Small starfish |
| 1971 | 11:00 | Station 5 | 10 | Starfish | 1 | 0.5 | 0 | 0 | 0 | 0 | Small starfish |
| 1971 | 11:15 | Station 6 | 10 | Starfish | 1 | 0.5 | 0 | 0 | 0 | 0 | Small starfish |
| 1971 | 11:30 | Station 7 | 10 | Starfish | 1 | 0.5 | 0 | 0 | 0 | 0 | Small starfish |
| 1971 | 11:45 | Station 8 | 10 | Starfish | 1 | 0.5 | 0 | 0 | 0 | 0 | Small starfish |
| 1971 | 12:00 | Station 9 | 10 | Starfish | 1 | 0.5 | 0 | 0 | 0 | 0 | Small starfish |
| 1971 | 12:15 | Station 10 | 10 | Starfish | 1 | 0.5 | 0 | 0 | 0 | 0 | Small starfish |
| 1971 | 12:30 | Station 11 | 10 | Starfish | 1 | 0.5 | 0 | 0 | 0 | 0 | Small starfish |
| 1971 | 12:45 | Station 12 | 10 | Starfish | 1 | 0.5 | 0 | 0 | 0 | 0 | Small starfish |
| 1971 | 13:00 | Station 13 | 10 | Starfish | 1 | 0.5 | 0 | 0 | 0 | 0 | Small starfish |
| 1971 | 13:15 | Station 14 | 10 | Starfish | 1 | 0.5 | 0 | 0 | 0 | 0 | Small starfish |
| 1971 | 13:30 | Station 15 | 10 | Starfish | 1 | 0.5 | 0 | 0 | 0 | 0 | Small starfish |
| 1971 | 13:45 | Station 16 | 10 | Starfish | 1 | 0.5 | 0 | 0 | 0 | 0 | Small starfish |
| 1971 | 14:00 | Station 17 | 10 | Starfish | 1 | 0.5 | 0 | 0 | 0 | 0 | Small starfish |
| 1971 | 14:15 | Station 18 | 10 | Starfish | 1 | 0.5 | 0 | 0 | 0 | 0 | Small starfish |
| 1971 | 14:30 | Station 19 | 10 | Starfish | 1 | 0.5 | 0 | 0 | 0 | 0 | Small starfish |
| 1971 | 14:45 | Station 20 | 10 | Starfish | 1 | 0.5 | 0 | 0 | 0 | 0 | Small starfish |
| 1971 | 15:00 | Station 21 | 10 | Starfish | 1 | 0.5 | 0 | 0 | 0 | 0 | Small starfish |
| 1971 | 15:15 | Station 22 | 10 | Starfish | 1 | 0.5 | 0 | 0 | 0 | 0 | Small starfish |
| 1971 | 15:30 | Station 23 | 10 | Starfish | 1 | 0.5 | 0 | 0 | 0 | 0 | Small starfish |
| 1971 | 15:45 | Station 24 | 10 | Starfish | 1 | 0.5 | 0 | 0 | 0 | 0 | Small starfish |
| 1971 | 16:00 | Station 25 | 10 | Starfish | 1 | 0.5 | 0 | 0 | 0 | 0 | Small starfish |
| 1971 | 16:15 | Station 26 | 10 | Starfish | 1 | 0.5 | 0 | 0 | 0 | 0 | Small starfish |
| 1971 | 16:30 | Station 27 | 10 | Starfish | 1 | 0.5 | 0 | 0 | 0 | 0 | Small starfish |
| 1971 | 16:45 | Station 28 | 10 | Starfish | 1 | 0.5 | 0 | 0 | 0 | 0 | Small starfish |
| 1971 | 17:00 | Station 29 | 10 | Starfish | 1 | 0.5 | 0 | 0 | 0 | 0 | Small starfish |
| 1971 | 17:15 | Station 30 | 10 | Starfish | 1 | 0.5 | 0 | 0 | 0 | 0 | Small starfish |
| 1971 | 17:30 | Station 31 | 10 | Starfish | 1 | 0.5 | 0 | 0 | 0 | 0 | Small starfish |
| 1971 | 17:45 | Station 32 | 10 | Starfish | 1 | 0.5 | 0 | 0 | 0 | 0 | Small starfish |
| 1971 | 18:00 | Station 33 | 10 | Starfish | 1 | 0.5 | 0 | 0 | 0 | 0 | Small starfish |
| 1971 | 18:15 | Station 34 | 10 | Starfish | 1 | 0.5 | 0 | 0 | 0 | 0 | Small starfish |
| 1971 | 18:30 | Station 35 | 10 | Starfish | 1 | 0.5 | 0 | 0 | 0 | 0 | Small starfish |
| 1971 | 18:45 | Station 36 | 10 | Starfish | 1 | 0.5 | 0 | 0 | 0 | 0 | Small starfish |
| 1971 | 19:00 | Station 37 | 10 | Starfish | 1 | 0.5 | 0 | 0 | 0 | 0 | Small starfish |
| 1971 | 19:15 | Station 38 | 10 | Starfish | 1 | 0.5 | 0 | 0 | 0 | 0 | Small starfish |
| 1971 | 19:30 | Station 39 | 10 | Starfish | 1 | 0.5 | 0 | 0 | 0 | 0 | Small starfish |
| 1971 | 19:45 | Station 40 | 10 | Starfish | 1 | 0.5 | 0 | 0 | 0 | 0 | Small starfish |
| 1971 | 20:00 | Station 41 | 10 | Starfish | 1 | 0.5 | 0 | 0 | 0 | 0 | Small starfish |
| 1971 | 20:15 | Station 42 | 10 | Starfish | 1 | 0.5 | 0 | 0 | 0 | 0 | Small starfish |
| 1971 | 20:30 | Station 43 | 10 | Starfish | 1 | 0.5 | 0 | 0 | 0 | 0 | Small starfish |
| 1971 | 20:45 | Station 44 | 10 | Starfish | 1 | 0.5 | 0 | 0 | 0 | 0 | Small starfish |
| 1971 | 21:00 | Station 45 | 10 | Starfish | 1 | 0.5 | 0 | 0 | 0 | 0 | Small starfish |
| 1971 | 21:15 | Station 46 | 10 | Starfish | 1 | 0.5 | 0 | 0 | 0 | 0 | Small starfish |
| 1971 | 21:30 | Station 47 | 10 | Starfish | 1 | 0.5 | 0 | 0 | 0 | 0 | Small starfish |
| 1971 | 21:45 | Station 48 | 10 | Starfish | 1 | 0.5 | 0 | 0 | 0 | 0 | Small starfish |
| 1971 | 22:00 | Station 49 | 10 | Starfish | 1 | 0.5 | 0 | 0 | 0 | 0 | Small starfish |
| 1971 | 22:15 | Station 50 | 10 | Starfish | 1 | 0.5 | 0 | 0 | 0 | 0 | Small starfish |
| 1971 | 22:30 | Station 51 | 10 | Starfish | 1 | 0.5 | 0 | 0 | 0 | 0 | Small starfish |
| 1971 | 22:45 | Station 52 | 10 | Starfish | 1 | 0.5 | 0 | 0 | 0 | 0 | Small starfish |
| 1971 | 23:00 | Station 53 | 10 | Starfish | 1 | 0.5 | 0 | 0 | 0 | 0 | Small starfish |
| 1971 | 23:15 | Station 54 | 10 | Starfish | 1 | 0.5 | 0 | 0 | 0 | 0 | Small starfish |
| 1971 | 23:30 | Station 55 | 10 | Starfish | 1 | 0.5 | 0 | 0 | 0 | 0 | Small starfish |
| 1971 | 23:45 | Station 56 | 10 | Starfish | 1 | 0.5 | 0 | 0 | 0 | 0 | Small starfish |
| 1971 | 24:00 | Station 57 | 10 | Starfish | 1 | 0.5 | 0 | 0 | 0 | 0 | Small starfish |
| 1971 | 24:15 | Station 58 | 10 | Starfish | 1 | 0.5 | 0 | 0 | 0 | 0 | Small starfish |
| 1971 | 24:30 | Station 59 | 10 | Starfish | 1 | 0.5 | 0 | 0 | 0 | 0 | Small starfish |
| 1971 | 24:45 | Station 60 | 10 | Starfish | 1 | 0.5 | 0 | 0 | 0 | 0 | Small starfish |



BEST AVAILABLE COPY

inch deep, were evident in the high-velocity units, with less severe deformation in the low-velocity units. The lower body surface deformation caused the external diameter to increase by 0.0035 inch to a maximum of 0.484 inch. This leaves a 0.006-inch minimum clearance, based on a 0.490-inch-diameter ogive bore. There was no significant difference between spring and crushwater supported units.

- (4) Lower body deformation from setback loads will increase firing-pin-to-detonator clearance. The rotor imprints [Conclusion (3)] will allow the rotor to set deeper when in-line, thus increasing the firing-pin-to-detonator clearance by the amount of lower body deformation (up to 0.010 inch for high-velocity units).
- (5) Some upper body damage occurs from softcatch. Upper body damage (cracks and deformation) location and type indicate the rotor was armed and the body assembly forward when the worst damage occurred. Evidence indicates that extremely high forward and side loading on the upper body occurred as caused by rapid deceleration and tumbling in the softcatcher. Some evidence of upper body deformation caused by lockweight was also noted. This later proved to be a significant factor in reducing fuze sensitivity.
- (6) The surface area of the lower body support post contributes to the degree of upper body deformation. The surface area of the lower body post varied considerably, and, in general, those with less area produce greater upper body damage from setback and/or set forward loading.

Delay Function Gun Tests

The test setup for this 42-shot test is shown in Figure 7. Photographs taken during this test series are presented in Appendix B. Data are summarized

in Table 6, which also defines the first three XM714A3 fuze design modifications evaluated (Mods I, II and III). These fuzes were evaluated at high (3500-ft/s) and low (2500-ft/s) velocities against the required 0.063- and 0.090-inch 2024-T3 aluminum targets at 0- and 80-degree obliquity. Also, high-velocity shots were conducted against simulated rain (0.0159-inch 2024-T3 aluminum at 0-degree obliquity) and against the desired 0.125-inch 2024-T3 aluminum target at 80-degree obliquity.

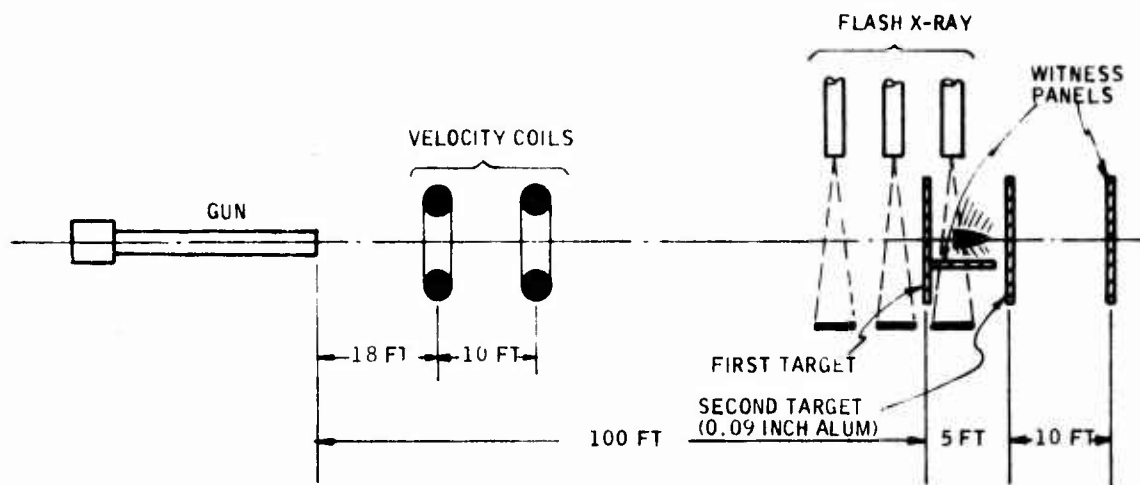

Figure 7. Test Setup - Delay Function Gun Tests

Fuze variations not defined in Table 6 included use of both C1144 and 17-4PH ogives with wall thicknesses of 0.03, 0.04 and 0.05 inch. The thin-wall ogive units were fired against thin (0.063-inch) aluminum targets. The ogives used in these tests were left over from the structural impact gun test described above. Ogives for final tests, IAT, delivery, etc., were fabricated from C1144 carbon steel with 0.05-inch walls as recommended earlier.

The XM714A3 Mod I provided delay functions on either the first or second target in 20 of 22 trials, excluding the four units fired against the simulated rain target (see Table 6). This would indicate a high function rate within an airplane target, as more than one impact would result from a hit. One of the

TABLE 6. XM714A3 EARLY TESTS AND RESULTS

| Fuze Identification | | | I | | | II | | | III | | |
|---|-----------------|----------------|--------------------------|-------------------------------------|----------|--------------------------|-------------------------------------|----------|--------------------------|-------------------------------------|----------|
| Piston Spring Force (lb) | | | 1.5 | | | 1.5 | | | 1.5 | | |
| Crushwasher | | | Original 2024-T4 | | | Setback Spring | | | Original 2024-T4 | | |
| Balls | | | None | | | 2-Nylon | | | None | | |
| FP-Detonator Clearance (in) | | | 0, 0.095, 0, 0.185 | | | 0, 0.095, 0, 0.185 | | | 0, 0.095, 0, 0.185 | | |
| Fabrication | | | Molykote | | | Molykote | | | Improved Molybutt | | |
| Body Assembly Effective Weight (lb) | | | 0, 0.0573 | | | 0, 0.0475 | | | 0, 0.0573 | | |
| First Target Impact Condition (2024-T3) | | | HO Delay on First Target | Second Target ^d Function | Failures | HO Delay on First Target | Second Target ^d Function | Failures | HO Delay on First Target | Second Target ^d Function | Failures |
| Velocity (ft/s) | Obliquity (deg) | Thickness (in) | | | | | | | | | |
| 1000 | 0 | 0.040 | | | | | | | | | |
| 2500 | 0 | 0.063 | 1 | 3 | 1 | 2 | 1 | | 8 | 2 | |
| | | 0.090 | 1 | | | | | | | | |
| | | 0.125 | | | | | | | | | |
| 3500 | 0 | 0.063 | 1 | | 1 | | | | | | |
| | | 0.090 | 4 | | | | | | | | |
| | | 0.125 | | | | | | | | | |
| 3500 | 80 | 0.063 | | | 4 | | | | | | |
| | | 0.090 | | 2 | | 1 | 2 | | | | |
| | | 0.125 | | | | | | | | | |
| 3500 | 80 | 0.063 | 2 | 1 | | | | | | | |
| | | 0.090 | 3 | | | | | | | | |
| | | 0.125 | 2 | | | | | | | | |
| Totals | | | 14 | 6 | 6 | 3 | 3 | 0 | 8 | 2 | 0 |
| ^d Second target = 0.090-inch 2024-T3 aluminum at 0-deg obliquity | | | | | | | | | | | |

two failures functioned high-order on a third target (steel plate), indicating a sensitivity-type failure. The other unit failed against both 0.090-inch aluminum, 80-degree obliquity and 0.090-inch aluminum, 0-degree obliquity impacts because the fuze broke off before detonation function occurred. The fuze ogive threads were modified (strengthened) to prevent this type of structural failure in later fuze modifications (Mods IV through XIV). All units armed properly as verified by flash x-ray, and all units which functioned went high-order. All first-target functions were delay functions (this later proved to be true for all fuze modifications evaluated).

The XM714A3 Mod II provided greater sensitivity than Mod I because the crushwasher was replaced with a 3.3-pound maximum (at 0.05 inch) setback spring (see Table 6). Two nylon balls held the body assembly aft during flight before impact. This design was not evaluated further, however, because the setback spring could cause the fuze to self-destruct the round when the spin decays from 2288 rev/s to approximately 900 rev/s (spin delay \approx 1300 to 1460 rev/s at 4000-meter slant range depending on aircraft velocity). The Air Force did not desire a self-destruct feature in the fuze.

The XM714A3 Mod III also provided greater sensitivity. This was accomplished by reducing firing pin-detonator clearance from 0.0895 ± 0.0185 inch to 0.0605 ± 0.0185 inch and improving lubrication. At the 0.063-inch aluminum, 0-degree obliquity, 2500-ft/s impact condition, sensitivity improved from 20 percent (Mod I) to 80 percent (Mod III). At high-velocity impacts, we would expect a sensitivity level against 0.090-inch aluminum to approach 50 percent at 0-degree obliquity. High-velocity impacts against 0.0625-inch aluminum at 0-degree obliquity would be less than 50 percent. It was, therefore, concluded that additional modifications to the fuze are desirable if the impact sensitivity requirements are to be met.

The 10-shot XM714A3 Mod III sensitivity gun test data were further analyzed, and delay function distance was determined from x-ray and witness panel

data. Distances of 5.3 to 9.8 inches were determined. Longer delay distances were achieved when the nylon ball was introduced in fuze Mods VIII, IX, and XI through XIV. These data allowed certain minor revisions to be made to the delay function computer mathematical model so modified fuze designs could be studied. The revised computer program showed good agreement with experimental results.

LABORATORY TESTS

Five laboratory tests were conducted during the program as discussed in the following paragraphs.

Explosive Loading Tests -- Projectile body structural integrity during 30,000-psi I.C.A. 1 HEI loading operations was one of the risk areas identified and analyzed. Projectile body diameters at various locations (Figure 8) were monitored at consolidation pressures up to 60,000 psi with no permanent deformation noted (Table 7). This same 60,000-psi test was repeated with two additional projectile bodies with similar results. Diameters were monitored on all 75 projectiles loaded for early tests, using a 30,000-psi consolidation pressure with no permanent deformation noted. It was concluded that the strength of the projectile bodies during explosive loading operations is adequate by a factor of safety greater than $\frac{60,000}{30,000} = 2.0$.

Detonator Sensitivity -- A 19-shot detonator sensitivity laboratory test was conducted to verify that the miniature stab detonator all-fire energy is 1.25 in-oz when the standard XM714A2 firing pin is used. The test was conducted as shown in Figure 9. Since all units (19 of 19) functioned, it was concluded that observed sensitivity failures are not caused by insensitive detonators.

Ogive Lubrication -- The revised C1144 carbon steel ogives used for final tests and delivery were cleaned and zinc plated per finish No. 1.9.2.3 of

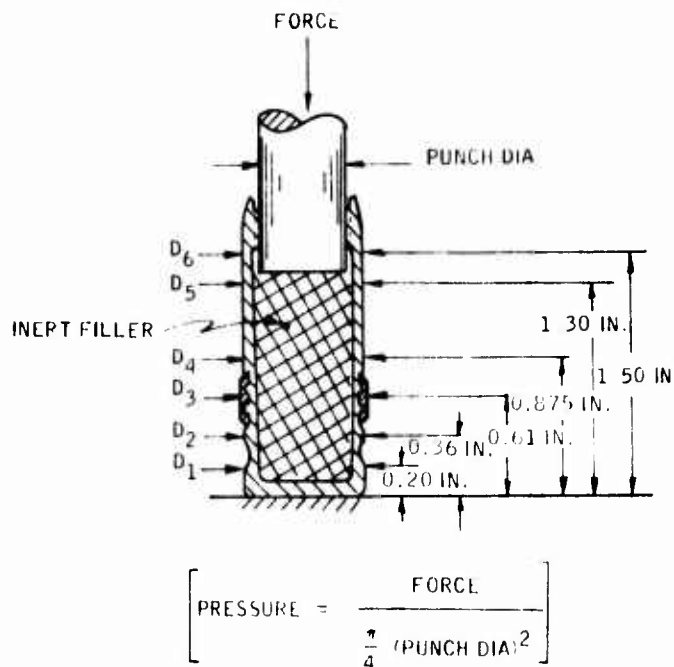

Figure 8. Projectile Body Strength Test Locations

TABLE 7. PROJECTILE BODY STRENGTH TEST RESULTS

| Force (lb) | Punch Dia (in) | Consolidation Pressure (kpsi) | Projectile Body Deformation (in) ^a | | | | | |
|------------|----------------|-------------------------------|---|----------------|----------------|----------------|----------------|----------------|
| | | | D ₁ | D ₂ | D ₃ | D ₄ | D ₅ | D ₆ |
| 0 | 0.585 | 0 | 0.765 | 0.767 | 0.824 | 0.783 | 0.783 | 0.783 |
| 1.343 | 0.585 | 5 | 0.765 | 0.767 | 0.824 | 0.783 | 0.783 | 0.783 |
| 2.689 | 0.585 | 10 | 0.765 | 0.767 | 0.824 | 0.783 | 0.783 | 0.783 |
| 4.030 | 0.585 | 15 | 0.765 | 0.767 | 0.824 | 0.783 | 0.783 | 0.783 |
| 5.373 | 0.585 | 20 | 0.765 | 0.767 | 0.824 | 0.783 | 0.783 | 0.783 |
| 6.714 | 0.585 | 25 | 0.765 | 0.767 | 0.824 | 0.783 | 0.783 | 0.783 |
| 8.059 | 0.585 | 30 | 0.765 | 0.767 | 0.824 | 0.783 | 0.783 | 0.783 |
| 9.403 | 0.585 | 35 | 0.765 | 0.767 | 0.824 | 0.783 | 0.783 | 0.783 |
| 10.746 | 0.585 | 40 | 0.765 | 0.767 | 0.824 | 0.783 | 0.783 | 0.783 |
| 12.089 | 0.585 | 45 | 0.765 | 0.767 | 0.824 | 0.783 | 0.783 | 0.783 |
| 13.432 | 0.585 | 50 | 0.765 | 0.765 | 0.824 | 0.783 | 0.783 | 0.783 |
| 14.775 | 0.585 | 55 | 0.765 | 0.767 | 0.824 | 0.783 | 0.783 | 0.783 |
| 16.119 | 0.585 | 60 | 0.765 | 0.767 | 0.824 | 0.783 | 0.783 | 0.783 |
| 16.119 | 0.585 | 60 | 0.765 | 0.765 | 0.824 | 0.783 | 0.783 | 0.783 |

^aAverage of two readings taken 90 degrees apart at zero load after consolidation

TEST OBJECTIVE: DETERMINE IF THE XM714 DETONATOR INITIATES RELIABLY AT 1-1/4 IN-OZ ENERGY WHEN TESTED WITH ACTUAL FUZE HARDWARE.

TEST PROCEDURE: DROP A 1/4-OZ WEIGHT 5 INCHES ONTO THE PISTON ASSEMBLY OF A MODIFIED FUZE AS SHOWN BELOW.

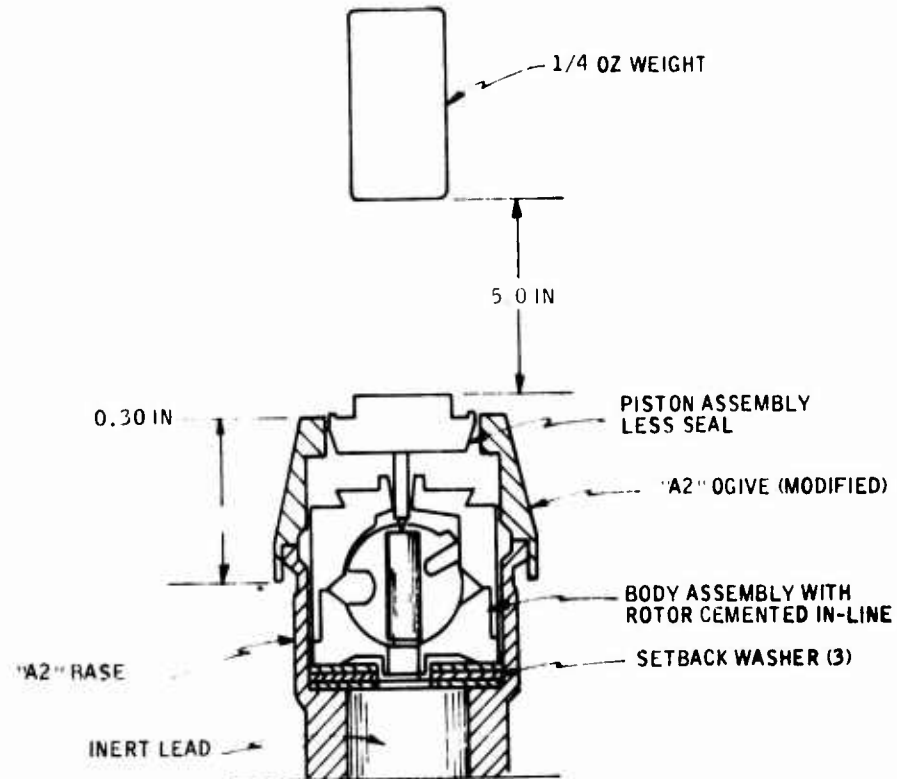

TEST RESULTS: 19 UNITS TESTED - ALL FUNCTIONED PROPERLY AT 1-1/4 IN-OZ.

Figure 9. Detonator Sensitivity Test Details

MIL-STD-171 (0.0002-inch-thick electro-deposited zinc). Uniform plating of the 0.490- and 0.380-inch inside-diameter portions was not achieved using standard plating practices, and rust had formed. A salvage analysis was conducted to determine a process for removing the rust and minimizing friction of the body assembly as summarized in Figure 10. Bead blasting followed by application of McLube 1720 (R) followed by Molybuffing^a resulted in friction coefficient reductions from $f = 0.45$ to 0.54 to $f = 0.11$ to 0.16 as presented in Table 8. This process was specified and used on all ogives for testing and delivery. During follow-on development, special plating fixtures may have to be developed to allow good circulation of the plating fluid in the inside-diameter portion of the ogive. Specification of electroless nickel coatings may also be considered.

Crushwasher Static Force Tests -- During final gun testing of fuze design modifications IV-VII, it was determined that the crushwasher would spring back to a height of 0.050 inch after setback (0.030 inch desired). This caused arming failures. Annealing the 2024-T4 aluminum crushwashers to condition 2024-0 corrected the springback problem. Force tests were conducted on two annealed crushwashers with results as shown in Figure 11. Maximum force was 72 to 77 pounds which corresponds to a setback level of $(\frac{72 \text{ to } 77}{0.00573 + 0.00144}) = 10,000$ to $11,000$ g required to flatten the crushwasher during gun launch (note: $0.00573 + 0.00144$ pound = body assembly + piston assembly weight). This corresponds to 20,000 to 26,000 g to flatten the earlier 2024-T4 designs (four tests).

^a A buffing process using Molykote (R).

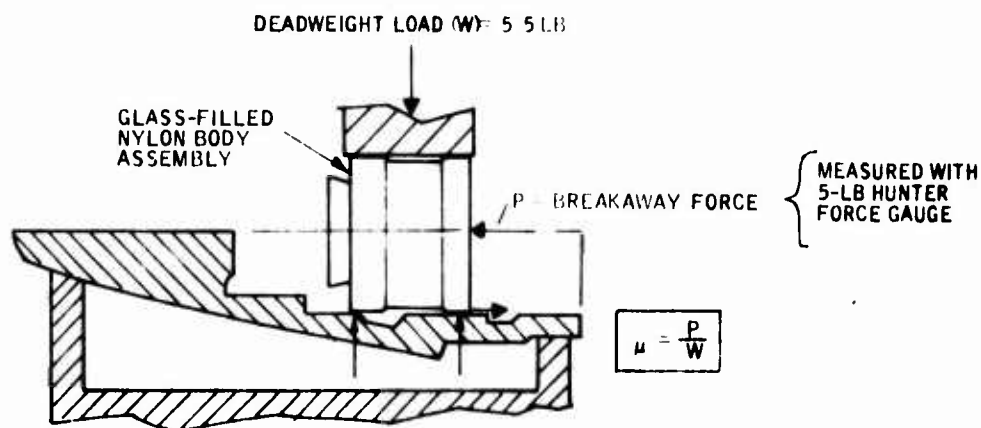

Figure 10. Ogive Salvage Analysis Test Setup

TABLE 8. OGIVE SALVAGE ANALYSIS RESULTS

| Ogive Identification | Internal Condition as Received | Salvage Rework to Eliminate Rust | Friction Determination After Rework (See Figure 10) | |
|----------------------|--------------------------------|---|---|-----------------------------|
| | | | Breakaway Force, P (lb) | Friction Coefficient, μ |
| A | Very rusty all over | • Sectioned as received | 2.5 - 3 | 0.45 - 0.54 |
| | | • 1/2 pencil sandblasted | 2 - 2.35 | 0.36 - 0.41 |
| B & C | Rusty in spots | Hand cleaned with alcohol and cotton swab. McLube 1720 ^(R) and Molybutt applied followed by sectioning | 0.6 - 1.0 | 0.11 - 0.18 |
| D | Very rusty all over | Pencil sandblasted plus McLube 1720 ^(R) and Molybutt followed by sectioning | 0.9 - 1.2 | 0.16 - 0.22 |
| E | Very rusty all over | Pencil sandblasted followed by sectioning | 1.5 - 2.0 | 0.27 - 0.36 |
| F | Good condition - no rust | • Sectioned as received | 1.7 - 2.0 | 0.31 - 0.36 |
| | | • Pencil bead blasted | ~ 2.0 | ~ 0.36 |
| G | Very rusty all over | Bead blasted with large Tech. Lab machine followed by sectioning | 1.5 - 2.0 | 0.27 - 0.36 |
| H | Very rusty all over | Pencil bead blasted plus McLube ^(R) and Molybutt followed by sectioning | 0.6 - 0.9 | 0.11 - 0.16 |

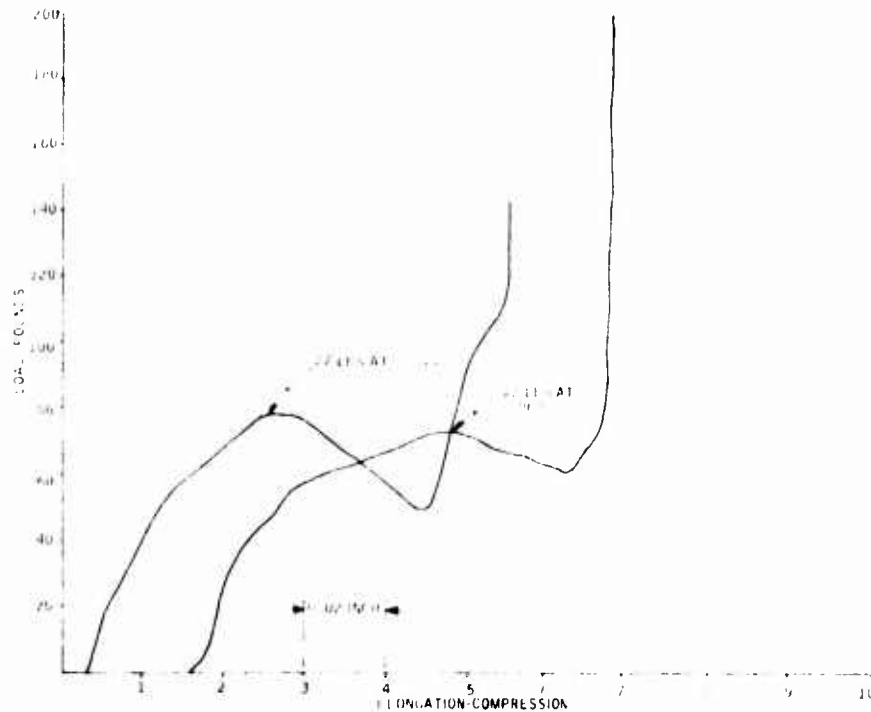

Figure 11. Annealed Crushwasher Force Test Results

Projectile Body Hardness -- The effect of plastic banding operations on projectile body hardness was determined on a sample of 18 units. The hardness requirement of the projectile body before banding is Rockwell C37 to C42. The measured hardness values before and after banding are presented in Table 9. A reduction in average hardness from RC41 to RC39 is apparently caused by projectile body preheating to 500 to 600°F during banding operations. Only 11 of 18 and 8 of 18 met the hardness specification before and after banding, respectively. Hardness deviation from specifications did not cause any projectile integrity problems during gun launch in 352 tests. Additional gun testing at overpressure will be required before recommending changing the hardness specification from RC37 to RC42 to, say, RC33 to RC45.

FINAL TESTS

The 120 final test units contained sliders (to increase body assembly effective mass), improved Molybuff lubrication, and reduced clearance to improve

TABLE 9. EFFECT OF PLASTIC BANDING OPERATIONS ON PROJECTILE BODY HARDNESS

| Unit No. | Rockwell Hardness | |
|----------|-------------------|---------------|
| | Before Banding | After Banding |
| 1 | RC41 | RC41 |
| 2 | RC45 | RC42 |
| 3 | RC43 | RC43 |
| 4 | RC42 | RC40 |
| 5 | RC45 | RC44 |
| 6 | RC46 | RC45 |
| 7 | RC37 | RC34 |
| 8 | RC39 | RC33 |
| 9 | RC39 | RC32 |
| 10 | RC43 | RC43 |
| 11 | RC43 | RC41 |
| 12 | RC37 | RC36 |
| 13 | RC43 | RC35 |
| 14 | RC39 | RC38 |
| 15 | RC40 | RC42 |
| 16 | RC41 | RC40 |
| 17 | RC38 | RC40 |
| 18 | RC39 | RC34 |
| Average | RC41 | RC39 |

sensitivity over that observed for early test units. Specific design and test quantities were as follows:

- 40 units - Fuze Mod IV per Figure 1 were MIL-STD safety tested (8 tests x 5 units/test = 40) followed by inspection of 21 units and delay function gun testing of 19 units per Figure 7 and Table 10.
- 20 units - Fuze Mod V per Figure 1 were delay function gun tested per Figure 7 and Table 10.
- 5 units - Fuze Mod VI per Figure 1 were delay function gun tested per Figure 7 and Table 10.
- 55 units - Fuze Mod VII per Figure 1 were delay function gun tested per Figure 7 and Table 10.

MIL-STD safety testing involved evaluating five units each of Fuze Mod IV for each of eight MIL-STD safety tests with results as follows:

- Jolt (Test No. 101 of MIL-STD-331) - Five of five units were inspected and passed the test.
- Jumble (Test No. 102 of MIL-STD-331) - Three of five units passed the test. The other two units came apart in the jumble box, i. e., base unscrewed from ogive as defined in the assembly drawing (see Figure 1). Application of an adhesive to the base threads or staking the ogive-base threads after assembly would prevent this problem. On the deliverable units, the fuze is assembled with sealing and locking compound applied to the fuze/projectile threads. Unscrewing of the base cannot occur under these conditions.

TABLE 10. XM714A3 FINAL TESTS AND RESULTS

| Fuze Modification | | IV | | | V | | | VI | | | VII | | |
|---|-----------------|--------------------------|--------------------|------------------------|------------------------|--------------------------|----------|------------------------|--------------------|--------------------------|------------------------|------------------------|----------|
| Piston Spring Force (lb) | | 1.5 | Modified 2024-T4 | | 0.9 | Tech Lab 2024-T4 | | 0.9 | None | | 0.9 | Annealed 2024-T4 | |
| Crushwasher Balls | | None | Improved Molybuiff | | None | Improved Molybuiff | | None | Improved Molybuiff | | None | Improved Molybuiff | |
| FP-Detonator Clearance (in) | | 0.0695-0.0165 | Improved Molybuiff | | 0.0695-0.0185 | Improved Molybuiff | | 0.0695-0.0185 | Improved Molybuiff | | 0.0695-0.0185 | Improved Molybuiff | |
| Body Assembly Effective Weight (lb) | | 0.0105 (body + slider) | Improved Molybuiff | | 0.0105 (body + slider) | Improved Molybuiff | | 0.0105 (body + slider) | Improved Molybuiff | | 0.0105 (body + slider) | Improved Molybuiff | |
| First Target Impact Condition (2024-T3) | | HO Delay on First Target | Failures | Second Target Function | Failures | HO Delay on First Target | Failures | Second Target Function | Failures | HO Delay on First Target | Failures | Second Target Function | Failures |
| Velocity (ft/s) | Obliquity (deg) | Thickness (in) | | | | | | | | | | | |
| 1000 | 0 | 0.040 | | | | | | | | | | | 3 |
| 2500 | 0 | 0.063 | | | 1 | | 4 | | | 4 | | 1 | 1 |
| | | 0.090 | | | | | | | | | | | |
| | | 0.125 | | | | | | | | | | | |
| | 80 | 0.063 | | | | | | | | | | | |
| | | 0.090 | | | | | | | | | | | |
| | | 0.125 | | | | | | | | | | | |
| 3500 | 0 | 0.016 | 3 | 13 | 4 | 1 | | | | 3 | 1 | | 1 |
| | | 0.063 | | | | | | | | | | | |
| | | 0.090 | | | 1 | | | | | 4 | | | 1 |
| | | 0.125 | | | | | | | | 3 | | | 1 |
| | 80 | 0.063 | | | 5 | | | | | | | | |
| | | 0.090 | | | 3 | | | | | 10 | | | |
| | | 0.125 | | | | | | | | 3 | | | 2 |
| Totals | | | 3 | 12 | 14 | 1 | 5 | 4 ^b | 0 | 41 ^c | 1 | 5 | 9 |

^aSecond Target = 0.090-inch 2024-T3 aluminum at 0-deg obliquity.

^bTwo units were low-order functions.

^cFive units were low-order functions.

- Waterproofness (Test No. 108 of MIL-STD-331) - Five of five units passed. Two were disassembled and inspected, and three were gun tested with functions on either the first or second target (see Figure 7 and Table 10).
- Five-Foot Drop (Test No. 111 of MIL-STD-331) - All five units were gun tested, with three functioning properly. The remaining two units were partially armed on impact with the first target. These units were dropped nose down and 45 degrees nose down. The partial arming failures were believed caused by crushwasher springback (washers were not annealed) which is not related to the Five-Foot Drop test.
- Static Detonator Safety (Test No. 115 of MIL-STD-331) - Five of five units passed the test at ambient temperatures.
- Salt Fog (Method 509 of MIL-STD-810B) - Five of five units passed. Two were disassembled, and three were gun tested.
- Vibration (Method 514.1 of MIL-STD-810B) - All five units were gun tested, with four functioning properly and one exhibiting arming failure. The arming failure was attributed to crushwasher springback and not vibration effects.
- Temperature/Humidity/Altitude (Method 518 of MIL-STD-810B) - Five of five units passed. Two were disassembled and inspected, and three were gun tested with proper functions on the second target.

All of the above discussed 19 gun tests on Fuze Mod IV MIL-STD safety test units were conducted at 3500 ft/s, 0-degree obliquity, against 0.063-inch 2024-T3 aluminum targets with a 0.090-inch second target placed 5 feet away as defined in Figure 7 and Table 10. As summarized above and in Table 10, 3 units delay functioned on the first target, 13 functioned on the second target, and 3 were failures (2 partial arms plus 1 arming failure - believed caused by crushwasher springback).

The remaining final tests on Fuze Mods V, VI, and VII were function delay gun tests. Fuze design characteristics and test results are defined and summarized in Table 10. Fuze Mod V was identical to the previously discussed Fuze Mod IV except that a 0.9-pound rather than 1.5-pound piston spring was employed. At low velocity (2500 ft/s), crushwasher springback after setback caused four of five units to fail to arm as shown in Table 10. At high velocity (3500 ft/s), only one partial arm occurred in 15 tests, which indicates that less springback occurs at high velocity (high setback). Functional sensitivity against 0.063-inch aluminum at 0-degree obliquity was very good with this design, i.e., 1/1 at 2500 ft/s and 4/5 at 3500 ft/s. This also proved true with Fuze Mod VII (which is identical to Mod V except that an annealed crushwasher is used), i.e., 4/5 at 2500 ft/s and 3/4 at 3500 ft/s (Table 11). This brings the total sensitivity function rate to 5/6 at 2500 ft/s and 7/9 at 3500 ft/s against 0.063-inch aluminum at 0-degree obliquity.

Fuze Mod VI was identical to Mod V except for the crushwasher, i.e.; the Tech Lab 2024-T4 washer indicated in Table 10 had an angle of 75 ± 2 degrees rather than 90 ± 2 degrees. This washer proved to spring back after setback as demonstrated by static crush tests and x-ray analysis of five gun test units wherein one unit failed to arm and two units were low-order functions and suspected partial arms (see Table 10).

Fuze Mod VII test results showed 9 failures in 55 tests (16 percent) as indicated in Table 10. These failures were: 3 units no arm, 4 units partial arm and 2 units dud (arming ?).

Five of the 41 first-target delay functions were low-order. As indicated, many of the failures were arming related. Since partial arming failures produce low-order functions and duds, some of the units in these categories may also have been partial arming failures (partial arming is very difficult to detect on flash x-ray pictures). Laboratory tests on the annealed crushwasher showed zero springback after setback, so it was established that the failures were not related to the crushwasher.

During the 22 to 26 March final test series, meetings were held with Eglin AFB personnel. Upon completion of the final test series, it was decided that an additional supplemental test series would be required to correct the arming problem before conducting a final design review meeting and fabrication of the 500-unit delivery quantity.

SUPPLEMENTAL TESTS

Three fuze designs (Mods VIII, IX and X) were fabricated for supplemental delay function gun tests. These designs used annealed crushwashers, improved Molybuff lubrication, increased firing pin-detonator clearance, and a 0.0105-pound body and slider. Design variations were as follows:

Mod VIII - Equipped with 0.55-pound piston spring and two nylon balls (see Figure 1).

Mod IX - Equipped with 0.9-pound piston spring and two nylon balls (see Figure 1).

Mod X - Equipped with 1.5-pound piston spring and no nylon balls (see Figure 1).

These design variations are further summarized with gun test data in Table 11. The data indicate no arming failures occurred when nylon balls were used. The sensitivity was reduced, however. Of three failures observed on Fuze Mod X, one was a partial arm and two were duds.

An analysis of the test data in Table 11 showed that nylon ball(s) should be employed in the fuze because:

- Longer delays were observed against 0.090-inch 2024-T3 aluminum at 0-degree obliquity and 3500 ft/s when nylon balls were employed

TABLE 11. XM714A3 SUPPLEMENTAL TESTS AND RESULTS

| Fuze Modification | | | VIII | | | IX | | | X | | |
|---|-----------------|----------------|--------------------------|-------------------------------------|----------|--------------------------|-------------------------------------|----------|--------------------------|-------------------------------------|----------|
| Piston Spring Force (lb) | | | 0.55 | | | 0.9 | | | 1.5 | | |
| Crushwasher | | | Annealed 2024-0 | | | Annealed 2024-0 | | | Annealed 2024-0 | | |
| Balls | | | 2-Nylon | | | 2-Nylon | | | None | | |
| FP-Detonator Clearance (in) | | | 0.0745-0.0185 | | | 0.0745-0.0185 | | | 0.0745-0.0185 | | |
| Lubrication | | | Improved Molybuff | | | Improved Molybuff | | | Improved Molybuff | | |
| Body Assembly Effective Weight (lb) | | | 0.010 (body + slider) | | | 0.010 (body + slider) | | | 0.0105 (body + slider) | | |
| First Target Impact Condition (2024-T3) | | | HO Delay on First Target | Second Target ^a Function | Failures | HO Delay on First Target | Second Target ^a Function | Failures | HO Delay on First Target | Second Target ^a Function | Failures |
| Velocity (ft/s) | Obliquity (deg) | Thickness (in) | | | | | | | | | |
| 1000 | 0 | 0.040 | | | | | | | | | |
| 2500 | 0 | 0.063 | | | | | | | | | |
| | | 0.090 | | | | | | | | | |
| | | 0.125 | | | | | | | | | |
| 80 | 0 | 0.063 | | | | | | | | | |
| | | 0.090 | | | | | | | | | |
| | | 0.125 | | | | | | | | | |
| 3500 | 0 | 0.015 | | | | | | | | | |
| | | 0.063 | 0 | 14 | 0 | | | | 3 | 9 | 3 |
| | | 0.090 | | | | 13 | 2 | 0 | | | |
| 80 | 0 | 0.063 | | | | | | | | | |
| | | 0.090 | | | | | | | | | |
| | | 0.125 | | | | | | | | | |
| Totals | | | 0 | 14 | 0 | 13 | 2 | 0 | 3 | 9 | 3 |
| ^a Second target = 0.090-in. 2024-T3 aluminum. 0.0-deg obliquity. | | | | | | | | | | | |

(from 7 inches with no balls to 10.5 inches with balls). This has been extrapolated to longer delays over the entire target-impact requirement spectrum from 7.5 ± 2.5 inches to 10 ± 4 inches.

- More sensitivity is potentially available by using lighter piston springs, lower ball ramp angles (currently 45 degrees), and/or reducing the number of balls from two to one.
- No arming failures or partial arms were observed in 29 of 29 shots when balls were used (Table 11).
- The body and slider were held back 0.01 ± 0.01 inch further on units with balls as verified by x-ray analysis. This also accounts for the longer observed function delays and more reliable arming.
- The projectile deceleration at the muzzle was determined to be 140g (140g x 0.0105-pound body/slider = 1.5 pounds) which causes body assembly to move forward against the piston spring on units with no balls. This would account for observed arming failures and partial arms on fuzes with no balls. The 140g deceleration was determined from observed velocities at 23-foot and 92-foot ranges, i. e.

$$\begin{aligned} \text{Deceleration (g)} &= \frac{V_m^2 \text{Lne} \frac{V_{23'}}{V_{92'}}}{g (R_{92} - R_{23})} = \frac{(3500)^2 \text{Lne} \frac{3476.16}{3386.62}}{(32.17) (92-23)} \\ &= 140g \end{aligned}$$

- No early burst chance when balls are employed; i. e., projectile deceleration to trigger = 1000g for two balls and 750g for one ball. This is very important during aircraft launch when the total velocity of the projectile is higher, resulting in increased deceleration due to aerodynamic drag; i. e., using the 140g example calculation for a 3800-ft/s muzzle velocity launch from an aircraft

traveling at Mach 0.9 (1005 ft/s), projectile deceleration could approach

$$\left(\frac{3800 + 1005}{3500}\right)^2 (140) \approx 260g$$

near the muzzle at high yaw.

A final design review meeting was held at the contractor's Hopkins plant on 7-8 April at which a complete XM714A3 design/test history (including 20 shots on ID) and failure analysis was presented and discussed. The failure analysis showed 31 failures in 205 tests (15%). Of 31 failures, 5 were "no tests" and 20 were no arm or partial arm, giving an arming problem of $\frac{20}{31-5} = 77$ percent. This percentage is probably greater because the remaining six units which were duds may have had arming-related problems; i. e., no arms are always duds. The contractor estimated that elimination of the arming problem should produce a reliability rate greater than 90 percent over the specified target-impact condition spectrum. Reliable arming was demonstrated during 29 shots of fuze Mods VIII and IX which contained nylon balls (see Table 11).

A summary of fuze and projectile characteristics and XM714A3 requirement-versus-performance comparisons were also presented in the design review meeting as shown in Tables 1 and 12, respectively. All requirements had been met or exceeded except for 0-degree obliquity function on thin (0.04-inch) aluminum at 1000 ft/s (0/2 functions) and function against thin (0.06-inch) aluminum at 3500 ft/s.

A Pre-LAT test of fuze Mod XI was recommended before final build, LAT, and delivery to (1) verify that the arming problem has been solved and (2) improve sensitivity. Characteristics of fuze Mod XI are:

| | |
|----------------------|-----------------|
| Piston Spring Force: | 0.55 pound |
| Crushwasher: | Annealed 2024-0 |
| Balls: | One nylon ball |

TABLE 12. XM714A3 REQUIREMENTS VERSUS PERFORMANCE

| Requirement | Performance |
|---|--|
| Delay function | Demonstrated (No SQ) |
| 20mm M61 Mann barrel compatibility | Demonstrated |
| Test 175 rounds, minimum | Tested 373 rounds |
| Demonstrate fuze survivability, sensitivity, delay function time, MIL-STD safety, and reliable arming | Demonstrated |
| Ogive length = 1.200 inches | 1.200 inches |
| Delay function against 2024-T3 aluminum: Thickness = 0.06 to 0.09 inch (0.125 desired) Velocity = 2500 to 3500 ft/s Obliquity = 0 to 80 degrees | OK except at 0.06 in. / 0 deg/3500 ft/s |
| Function against 0.040-inch aluminum at 1000 ft/s | 0/2 |
| Fuze function on breakup | Demonstrated |
| Delay distance of 9 inches nominal | 10 ±4 inches |
| No self-destruct | Demonstrated |
| No function rain (0.0159-inch alum.) | 0/4 |
| Bore safe/arm within 100 feet | 40/40 |
| Projectile length 3.05 to 3.40 inches / 2.600-inch protrusion | 3.05/2.600 |
| Projectile weight of 1200 to 1300 grains (±30 grains) | 1226 grains |
| C/M = 0.30 minimum | 0.342 |

FP-Detonator Clearance: 0.0745 ±0.0185 inch
 Lubrication: Improved Molybuff
 Body Assembly Effective Weight: 0.0105 pound (body + slider)

The Air Force agreed with the contractor's recommendation and specified that the following procedure be followed:

- Document recommendations and proposed Pre-LAT plans in a letter to ADTC/Eglin.
- Build and evaluate a 20-unit Pre-LAT sample and telephone and document test results and conclusions to ADTC/Eglin AFB.
- Fabricate final LAT and deliverable quantity, evaluate (LAT), and telephone and document LAT results.
- Pack 500 fuzed projectiles and deliver as follows:

| <u>Qty</u> | <u>Item Description</u> | <u>Ship to</u> |
|------------|-----------------------------|-------------------------------------|
| 360 | Projectile Assembly (Live) | Eglin AFB |
| 40 | Projectile Assembly (Inert) | Eglin AFB |
| 100 | Projectile Assembly (Live) | Southwest Research Institute (Army) |

LOT ACCEPTANCE TESTS

A 20-shot Pre-LAT test was conducted on 15 April. These results were telephoned to Eglin AFB on 19 April, and approval to begin fabrication of the delivery quantity of the Mod XI design was given on 26 April. This was documented, as required, by letter. The test setup is shown in Figure 7. Pre-LAT test information is summarized as follows:

| Number of Shots | Armed Fuzes | First Target | Velocity (ft/s) | Results |
|-----------------|-------------|---------------------|-----------------|--|
| 5 | 5 | 0.063 in. at 0 deg | 3500 | 0/5 (4 second-target functions, 1 no function) |
| 6 | 6 | 0.090 in. at 0 deg | 3500 | 6/6 |
| 5 | 5 | 0.080 in. at 0 deg | 3500 | 3/5 (2 second-target functions) |
| 4 | 4 | 0.090 in. at 80 deg | 3500 | 4/4 (2 low-order on first target) |

Sensitivity against 0.063-inch aluminum at 0-degree obliquity and 3500 ft/s was not attained with the deliverable configuration; however, it was demonstrated that this could be attained with other fuze modifications tested (7/9 functions demonstrated with Fuze Mods V and VII (see Table 10). Sensitivity against the thin target at high velocity can be demonstrated and achieved if the Air Force elects to continue this program into engineering development. A reduction in ramp angle should provide the required sensitivity.

The final 20-shot LAT was conducted on the XM714A3 Mod XI fuzed HEI loaded 20mm projectile on 6 May using the same setup (see Figure 7) with results as follows:

| Number of Shots | Armed Fuzes | Velocity (ft/s) | First Target | Results |
|-----------------|-------------|-----------------|---|---|
| 10 | 10 | 3500 | 0.090-in. 2024-T3 aluminum at 0-deg obliquity | 9/10 (One unit functioned high-order on second 0.090-in. aluminum target) |
| 10 | 10 | 2500 | ↓ | 10/10 |

Eglin AFB provided Government monitoring of these tests by DCAS. Based on the above results, the contractor shipped 500 fuzed projectiles as follows:

| <u>Qty</u> | <u>Description</u> | <u>Ship to:</u> |
|------------|--|---|
| 360 | Projectile Assembly, 20mm, HEI, Test Vehicle (Live) | Transportation Office FK2823 Eglin AFB, Florida 32542 Attn: ADTC/DI.DD (Sy Slotkin) M/F: Contract F08635-76-C-0139 |
| 40 | Projectile Assembly, 20mm, HEI, Test Vehicle (Inert) | ↓ |
| 100 | Projectile Assembly, 20mm, HEI, Test Vehicle (Live) | Southwest Research Institute 8500 Culebra Road San Antonio, Texas 78284 Attn: Alex Wenzel |

Detailed fuze and projectile build information and x-ray data on all 520 fuzes (20 used for final-LAT) were also supplied with the shipment.

EGLIN TESTS

A total of 307 gun tests (267 live and 40 inert) were conducted by ADTC/Eglin AFB on the above defined deliverables during June and July. The contractor was invited to witness these tests and was given access to the raw data. The contractor's general impressions and conclusions are reported here to rationalize the 90-shot post delivery test series reported later.

Structural Integrity Gun Tests

The 40-shot inert-fuzed projectile test series was conducted to evaluate structural integrity after the most severe required (or desired) impact conditions. Structural integrity was achieved on all required and some desired impact conditions as summarized below:

| <u>Impact Velocity (ft/s)</u> | <u>2024-T3 Target Thickness (in.)</u> | <u>Target Obliquity (deg)</u> | <u>Requirement</u> | <u>Projectile/Fuze Ogive Condition After Impact</u> |
|-------------------------------|---------------------------------------|-------------------------------|--------------------|---|
| 2500 | 0.090 | 80 | Yes | Intact |
| 3500 | 0.090 | 80 | Yes | Intact |
| 2500 | 0.125 | 70 | Goal | Intact |
| 3500 | 0.125 | 70 | Goal | Intact |
| 2500 | 0.125 | 80 | Goal | Some intact/some breakup |
| 3500 | 0.125 | 80 | Goal | Breakup |

Delay Function Gun Tests

The 267-shot live-fuzed projectile test series was conducted to evaluate fuze delay functions against a complete matrix of impact conditions (3 velocities x 3 targets x 6 obliquities = 54) as defined below:

| <u>Impact Velocity (ft/s)</u> | <u>2024-T3 Target Thickness (in.)</u> | <u>Target Obliquity</u> | <u>Requirement/Goal</u> |
|-------------------------------|---------------------------------------|---------------------------------|-------------------------|
| 2500 | 0.063 | (0, 20, 40, 60, 70, and 80 deg) | Requirement |
| ↓ | 0.090 | | Requirement |
| ↓ | 0.125 | | Goal |
| 3000 | 0.063 | | Requirement |
| ↓ | 0.090 | | Requirement |
| ↓ | 0.125 | | Goal |
| 3500 | 0.063 | | Requirement |
| ↓ | 0.090 | | Requirement |
| ↓ | 0.125 | | Goal |

Approximately 5 shots were fired for each of the 54 possible impact conditions. Eglin's test setup was similar to the setup shown in Figure 7 except that 0.100-inch 2024-T3 aluminum was specified for the second target.

Data from these tests are plotted in Figures 12, 13 and 14 for impact velocities of 2500, 3000, and 3500 ft/s, respectively. Actual numbers of delay functions are not recorded because data are only preliminary and have not been completely analyzed and published. Delay functions during contractor LAT tests are recorded as shown. Three general regions are shown in Figures 12 through 14 as defined below:

- Reliable First-Target Delay Function (data \approx 4/5 or 5/5 delay functions).
- Marginal First-Target Function/Reliable Second-Impact Function (data \approx 1/5 to 3/5 delay functions with high function rate on second target).
- High Failure Rate Area (data \approx 0/5 to 2/5 delay functions with low function rate on second target).

Reliable first-target delay function was observed over the major portion of both the required and desired target-velocity spectrum. When first-target delay function was not obtained, a second-target function was obtained on all but the desired heavy target (0.125-inch aluminum) at low angles of obliquity and high (3500-ft/s) velocity. A realistic evaluation of target defeat requirements is recommended before deciding if the sensitivity and structural integrity of the fuze need be upgraded to fully provide first-target delay function over the complete spectrum.

Target-Velocity Spectrum Comments

To establish the realism of the target spectrum used in evaluating the performance of the XM714A3 delay fuze several points should be made:

- It has been estimated by user groups that approximately 80 percent of the target impacts will occur in air combat at angles of obliquity of 40 degrees or greater.

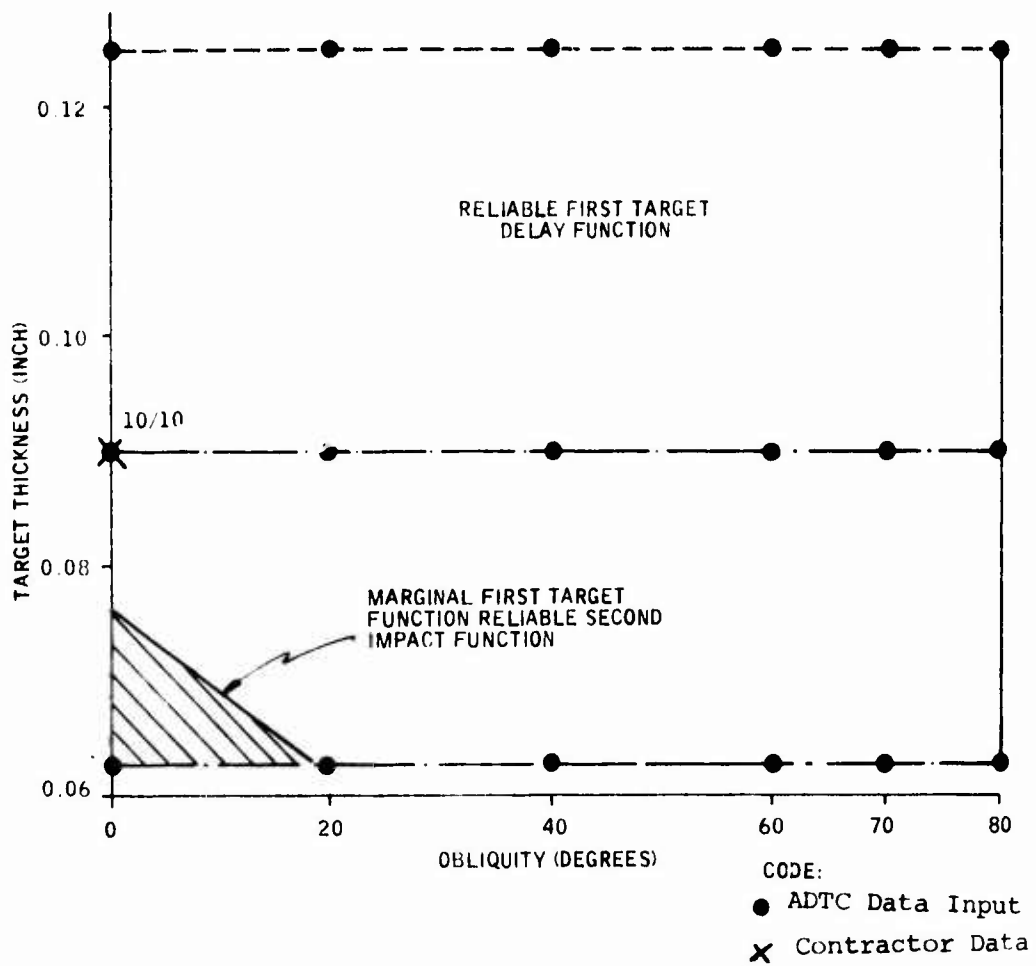

Figure 12. ADTC Delay Function Fuze Test Results - Impact Velocity = 2500 ft/s

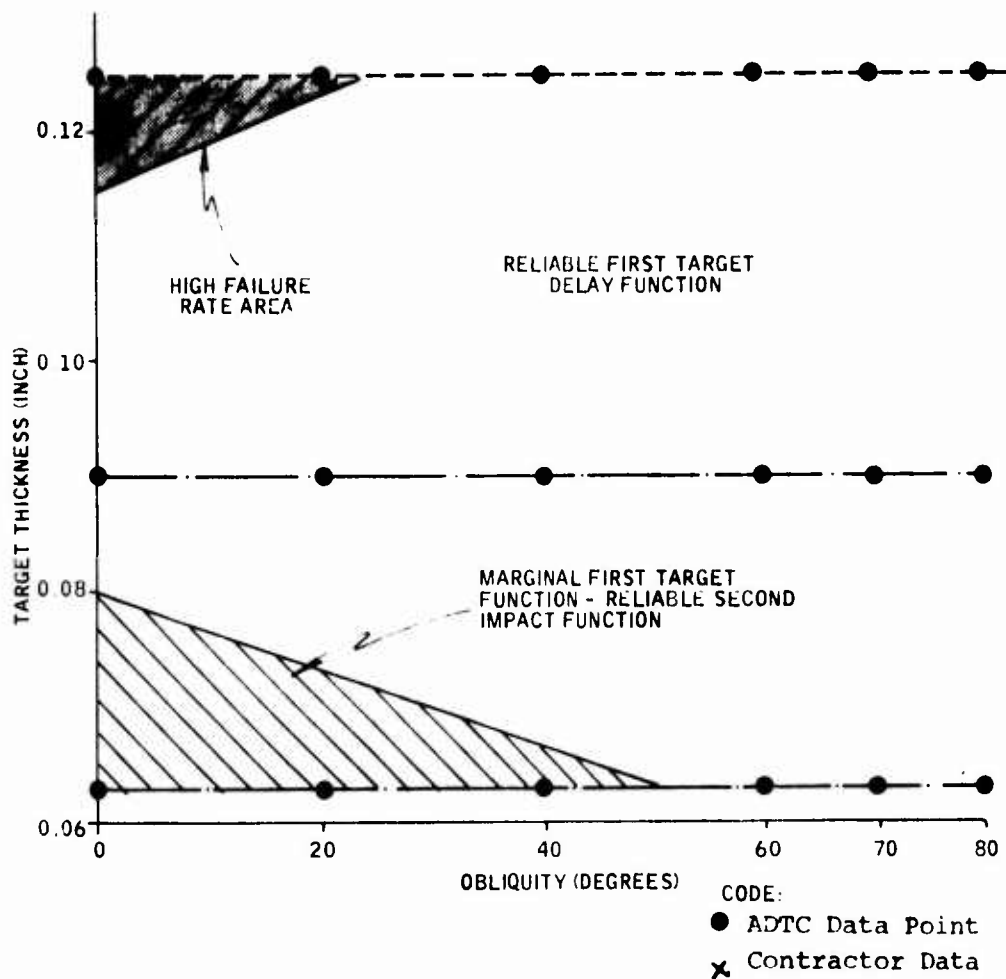

Figure 13. ADTC Delay Function Fuze Test Results -
Impact Velocity = 3000 ft/s

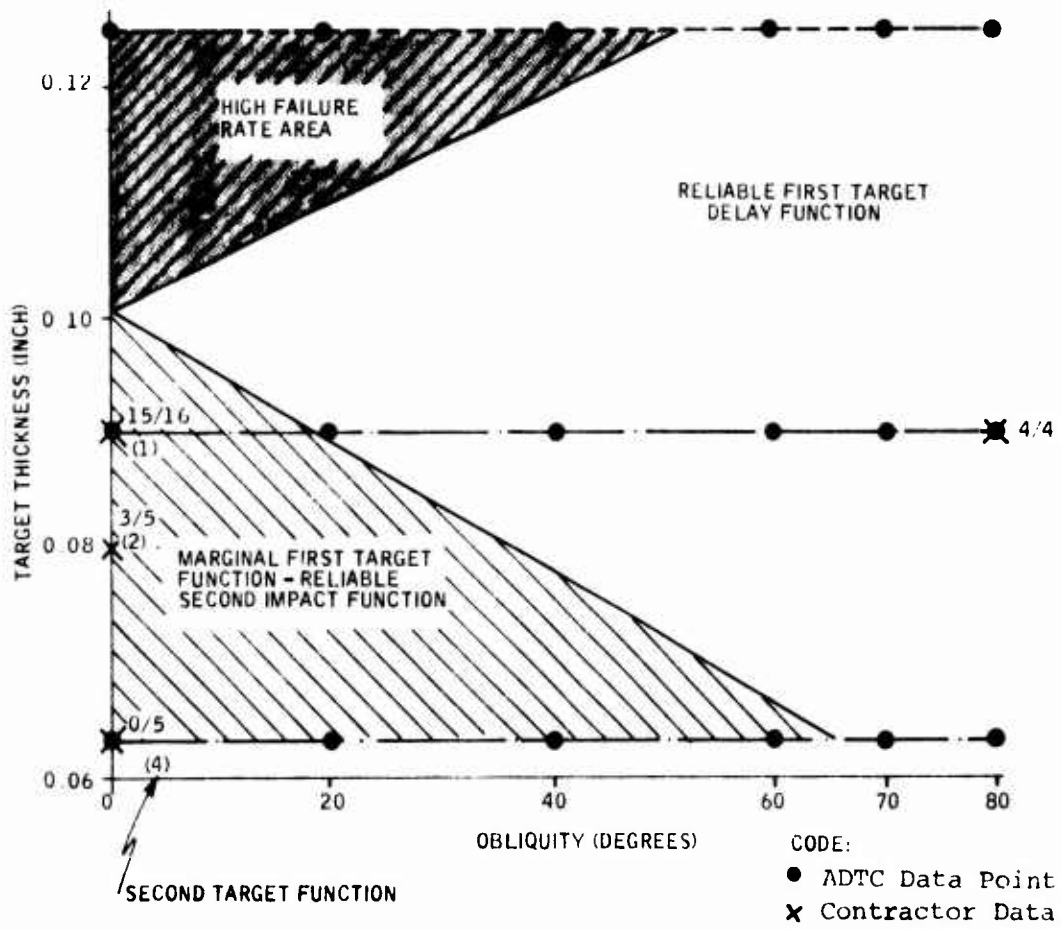

Figure 14. ADTC Delay Function Fuze Test Results - Impact Velocity = 3500 ft/s

- Based on the ballistic predictions for the lightweight 20mm projectile, we would not expect to see target impact velocities above 3000 ft/s for side and tail chase encounters. Table 13 gives predicted performance based on the lightweight test projectile used in the development contract.
- Based on the requirement for the development of improved 20mm ammunition, nominal function delay of 0.27 millisecond (0.55 millisecond maximum) against 0.060- to 0.090-inch 2024-T3 aluminum targets at 0- to 80-degree obliquity and 2750 ±250 ft/s impact velocity is required.

The points referenced seem to indicate that there is little realism in the 3500-ft/s impact condition and few probabilities of impacting light or heavy targets at 0-degree obliquity. This data would seem to indicate that, unless other factors are involved, the sensitivity and survivability of the XM714A3 delay fuze as tested by ADTC will provide the combat effectiveness desired in a delay fuze. The failures to function which did occur in the ADTC test program were at the 3500-ft/s impact velocity, which may be an unrealistic condition, and they did occur at low angles of obliquity which will seldom occur. In the area of sensitivity, where against light targets at low angles of obliquity only a reliable second-target function was obtained, the occasions where this will occur are small, and in these cases the probability of encountering additional structure after initial penetration of the skin is high. In fact, to achieve maximum effect, it may be preferable to delay function until such a second target is encountered to maximize the on-target effects.

POST-DELIVERY TESTS

Post-delivery tests were authorized by Eglin AFB to characterize projectile accuracy, rotating band retention, fuze sensitivity, and function against

TABLE 13. BALLISTIC PREDICTIONS FOR LIGHTWEIGHT
20mm TEST PROJECTILE

| Parameter | Value | | | | | |
|--|-------|-------|-------|-------|-------|-------|
| A/C Velocity (ktas) | 0 | | | 550 | | |
| Launch Alt. (ft) | 100 | | | 10K | | |
| Slant Range (ft) | 2500 | 4000 | 6000 | 2500 | 4000 | 6000 |
| Time of Flight (sec) | 0.902 | 1.96 | --- | 0.633 | 1.187 | 2.319 |
| Velocity (ft/s) | 1912 | 1074 | | 3176 | 2305 | 1360 |
| Tail Chase Attack (Mach 0.9 Coincident Aircraft Velocities) at 10,000 ft AMSL | | | | | | |
| Slant Range Attack (ft) | | 1500 | 2000 | 2500 | 3000 | |
| Intercept Time (sec) | | 0.467 | 0.684 | 0.942 | 1.290 | |
| Intercept Velocity, Absolute (ft/s) | | 3549 | 3097 | 2657 | 2193 | |
| Intercept Velocity, Relative (ft/s) | | 2562 | 2098 | 1676 | 1213 | |

0.125-inch aluminum under impact conditions simulating air-to-air combat. These 90 shots and their analysis are presented as follows:

- Rotating band/accuracy evaluation (15 shots)
- Fuze sensitivity evaluation (30 shots)
- Ogive integrity softcatch evaluation (15 shots)
- Body assembly integrity softcatch evaluation (10 shots)
- 500-meter function demonstration (20 shots)
- Performance analysis

Rotating Band/Accuracy Evaluation

The 15-shot rotating band/accuracy evaluation was authorized to demonstrate the mechanically retained polyarylene rotating band performance (band retention and projectile accuracy) as a function of lot-to-lot variations and exposure to the 28-day temperature and humidity cycling per Test 105 of MIL-STD-331. This was done by firing three groups of five units each at 3700-ft/s muzzle velocity in the 1707-inch-long Hopkins indoor range using a Mann barrel supported in a rigid gun mount. The first group (units 785-789) contained projectile bodies equipped with polyarylene bands from an old, untested lot. The second (units 790-794) and third (units 795-799) groups contained polyarylene bands from the same lot of material as used in all tests and deliverables during the subject program. The third group was exposed to the 28-day temperature and humidity cycling before firing.

Test results are summarized and highlighted in Table 14. Typical inflight photographs of unit 795 are shown in Figure 15 (photos of the other 14 units were identical to that shown in Figure 15). Conclusions were as follows:

- Projectile accuracy is less than 1 mil regardless of lot or T&H exposure.

TABLE 14. TEST PROJECTILE BAND RETENTION AND ACCURACY

| Fuze/ Projectile Number | Polyarylene Rotating Band | | Projectile Assembly Weight (grains) | Propellant Weight and Type | Velocity 79 ft Downrange (ft/s) | Percent Band Retention | Projectile Measured Spin Rate (rev/s) | Projectile Yaw at 1707 inches (degrees) | Avg (\bar{x}) and Std Dev (σ) of Radius (mils) |
|-------------------------------|------------------------------|---|--|-----------------------------------|--|------------------------------|--|--|--|
| | Lot Description | Environment Exposure | | | | | | | |
| 785 | Untested old lot | Fired at room temp | 1233 | 40.0 grains of Hodgdon H870 | 3593 | 100 | 2060 | 0 | \bar{x} = 1.03 σ = 0.83 at 1707 inches |
| 786 | | | 1231 | | 3610 | 100 | 2100 | 3 | |
| 787 | | | 1228 | | 3608 | 100 | 2170 | 0 | |
| 788 | | | 1231 | | 3614 | 100 | 2170 | 0 | |
| 789 | | | 1225 | | 3577 | 100 | 2200 | 0 | |
| 790 | Tested original lot | Fired at room temp | 1231 | | 3598 | 100 | 2190 | 0 | \bar{x} = 0.37 σ = 0.28 at 1707 inches |
| 791 | | | 1234 | | 3587 | 100 | 2190 | 0 | |
| 792 | | | 1233 | | 3593 | 100 | 2200 | 0 | |
| 793 | | | 1230 | | 3587 | 100 | 2190 | 0 | |
| 794 | | | 1232 | | 3579 | 100 | 2200 | 0 | |
| 795 | Tested original lot | Fired at room temp following 28-day T and H per test 105 of MIL-STD- 331 | 1229 | | 3598 | 100 | 2200 | 0 | \bar{x} = 0.84 σ = 0.71 at 1707 inches |
| 796 | | | 1231 | | 3603 | 100 | 2190 | 0 | |
| 797 | | | 1229 | | 3581 | 100 | 2190 | 0 | |
| 798 | | | 1228 | | 3601 | 100 | 2200 | 0 | |
| 799 | | | 1229 | | 3558 | 100 | 2190 | 0 | |

Notes:

- 1 - For 15-shot composite, \bar{x} = 0.86 mil and σ = 0.81 mil at 1707 inches range
- 2 - Drawings: cartridge = 28111700-002/projectile = 28111701-002/fuze = 28111604-003 (m.r.t)
- 3 - Estimated muzzle velocity = (3598 + 3589 + 3588) 1/3 + 79 (1.3 ft/s/ft) = 3694 3700 ft/s

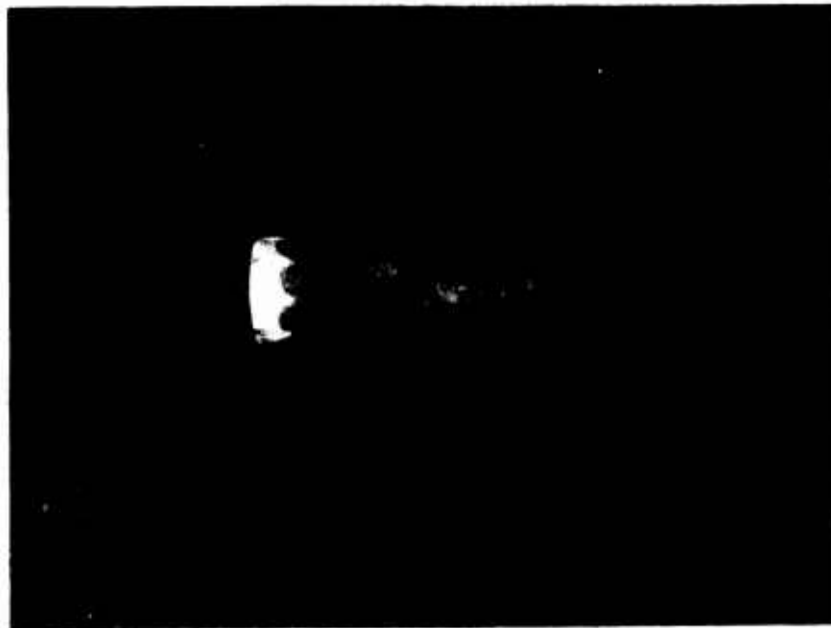

(a) Single Exposure of Projectile



(b) Double Exposure of Projectile

Figure 15. Inflight Photographs of Polarylene-Banded Projectile Assembly (Shot No. 795) after Exposure to 28-day Temperature and Humidity (Test 105 of Mil-Std 331)

- Full spin rate was achieved with 100 percent band retention noted as determined by double exposure photographs taken during 180 degrees of projectile rotation as shown in Figure 15.
- Projectile yaw, as determined by photographs 30 feet downrange (Figure 15) and photopaper yaw cards 1707 inches downrange, was 0 degree.

Fuze Sensitivity Evaluation

The 30-shot fuze sensitivity evaluation was authorized to demonstrate 0.063-inch aluminum sensitivity improvements expected by reducing ramp angle from 45 degrees (deliverable units) to 15 to 25 degrees and to determine if a sensitivity problem exists on impacts against 0.125-inch aluminum. This test was planned after witnessing Eglin AFB tests on deliverable fuzes where it was noted that sensitivity failures occurred at 3500-ft/s and 0-degree obliquity impacts against 0.063- and 0.125-inch 2024-T3 aluminum. Three fuze design modifications were evaluated as defined below (see Figures 1 and 6 for further fuze design clarification):

| <u>Fuze Modification</u> | <u>XII</u> | <u>XIII</u> | <u>XIV</u> |
|-------------------------------------|---|-----------------|-----------------|
| Unit Numbers | 800-809 | 810-819 | 830-839 |
| Piston Spring Force (lb) | 0.55 | 0.55 | 0.55 |
| Crushwasher | Annealed 2024-0 | Annealed 2024-0 | Setback Spring |
| Balls | 2 - Nylon | 2 - Nylon | 2 - Nylon |
| Firing Pin-Detonator Clearance (in) | 0.0745 ± 0.0185 | 0.0695 ± 0.0185 | 0.0695 ± 0.0185 |
| Lubrication | Improved Molybuff on ogive, slider, and balls | | |
| Body Assy Effective Weight (lb) | 0.0105 | 0.0105 | 0.00573 |
| Ramp Angle (deg) | 15 | 15 | 25 |

All units were evaluated at 3500-ft/s, 0-degree obliquity impacts against a 2024-T3 aluminum target placed 100 feet downrange. A second, 0.090-inch 2024-T3 aluminum, target was placed 5 feet behind the first target. Projectile velocity was monitored 23 feet downrange. Yaw paper was placed behind the second target, and fuze arming was verified by two x-ray units placed 46 and 251 inches forward of the first target. Results were as follows:

| <u>Fuze Mod</u> | <u>First-Target Thickness (in)</u> | <u>First-Target Function</u> | <u>Second-Target Function</u> | <u>Dud</u> | <u>Comments</u> |
|-----------------|------------------------------------|------------------------------|-------------------------------|------------|--------------------|
| XII | 0.080 | 1 | 4 | | |
| | 0.125 | | | 5 | (1 arming failure) |
| XIII | 0.063 | | 5 | | |
| | 0.125 | | | 5 | |
| XIV | 0.063 | 1 | 3 | 1 | (1 arming failure) |
| | 0.125 | | | 5 | (1 arming failure) |

After firing 10 Fuze Mod XIV and 8 Fuze Mod XIII units, one of the x-ray units was moved to a position behind the first target to determine the cause of the duds. Several good-quality x-ray pictures indicated that the ogive was swagged inward after 0.125-inch aluminum impacts. This could cause the body assembly to be trapped before moving forward after impact. No ogive deformation was noted on 0.080-inch aluminum impacts.

Ogive Integrity Softcatch Evaluation

The 15-shot ogive integrity softcatch evaluation was authorized to verify the ogive deformation hypothesis on impacts with 0.125-inch aluminum at 3500-ft/s, 0-degree obliquity. All 15 cartridges were loaded with 38.0 grams of Olin WC 870 propellant (3500-ft/s muzzle velocity) and fired 100 feet through 0.125-inch aluminum into a softcatcher containing polystyrene beads. The fuzes were inert and were equipped with the following ogives:

- Units 820 - 824: AISI 1144 steel ogive with 0.05-inch wall, 25-degree ramp angle, and measured hardness of Rockwell RC-28.5.
- Units 825 - 829: AISI 1144 steel ogive with 0.05-inch wall, 45-degree ramp angle, and measured hardness of Rockwell RC-30 (same ogive as used for deliverables).
- Units 840 - 844: 17-4 PH stainless steel ogive with 0.04-inch wall (no 0.05-inch-walled versions available) and 45-degree ramp angle. These ogives were left over from our early tests and were hardened to condition H925.

All 15 fuzes armed properly, and softcatch recovery results are summarized in Table 15. The annealed crushwashers were examined and were judged to have performed properly based on the dimensional analysis in Table 15. Significant ogive deformation and body assembly damage was noted. Near the junction between the ogive 0.380- and 0.490-inch diameters, diameter reductions of 0.007 to 0.016 and 0.018 to 0.022 inch, respectively, were noted. This caused the body assembly to be jammed in every case, as indicated in Table 15. Units with AISI 1144 ogives (numbers 820-829) required between three and eight blows with a hammer to remove the body and piston assemblies from the ogive as indicated. Units with 17-4 PH ogives also contained jammed body assemblies, however, the force required for removal was significantly less. Cracks in the glass-filled nylon upper body were noted in 12 of 15 units tested.

It was concluded that ogive deformation caused the Eglin AFB/Contractor-demonstrated failures against 0.125-inch aluminum at 0-degree obliquity and 3500 ft/s. This type of impact is unlikely to occur during air-to-air combat, i. e., velocity too high, obliquity too low, target too thick. If it is desired, however, to provide function delays against this type of impact

TABLE 15. FUZE DAMAGE AFTER 3500-FT/S, 0-DEGREE OBLIQUITY IMPACTS AGAINST 0.125-INCH 2024-T3 ALUMINUM PLATE

| Unit No. | Ogive Definition | Softcatch Recovery Damage | | | | | | | |
|----------|--|---------------------------|-------------|----------------|-----------------------|-----------------------|---------------|-----------------------|---------------------|
| | | Crushwasher | | | Ogive | | | Body Assembly | |
| | | OD (in) | ID (in) | Thickness (in) | 0.380±0.003 dia. (in) | 0.490±0.003 dia. (in) | Jammed? | 0.483-0.004 dia. (in) | Upper Body Cracked? |
| 820 | | 0.477-0.486 | 0.300-0.308 | 0.027 | 0.364 | 0.469 | Yes | 0.471-0.474 | Yes |
| 821 | AISI 1144 Steel RC-28, 0.03-in. Wall | 0.475-0.484 | 0.300-0.311 | 0.026-0.030 | 0.365 | 0.470 | Yes (8 Blows) | 0.471-0.477 | No |
| 822 | | 0.476-0.487 | 0.295-0.310 | 0.027-0.030 | 0.367 | 0.470 | Yes (8 Blows) | 0.472-0.477 | Yes (Many) |
| 823 | | 0.475-0.485 | 0.295-0.311 | 0.025-0.028 | 0.365 | 0.469 | Yes (5 Blows) | 0.471-0.475 | Yes |
| 824 | | 0.475-0.485 | 0.298-0.308 | 0.025-0.030 | 0.366 | 0.472 | Yes (5 Blows) | 0.474-0.475 | Yes |
| 825 | | 0.475-0.486 | 0.024-0.030 | 0.024-0.030 | 0.364 | 0.468 | Yes (6 Blows) | 0.469-0.474 | No |
| 826 | | 0.475-0.487 | 0.025-0.030 | 0.025-0.030 | 0.365 | 0.468 | Yes (4 Blows) | 0.468-0.473 | Yes |
| 827 | AISI 1144 Steel RC-30, 0.03-in. Wall | 0.476-0.487 | 0.300-0.312 | 0.026-0.030 | 0.364 | 0.469 | Yes (5 Blows) | 0.471-0.477 | Yes |
| 828 | | 0.475-0.484 | 0.295-0.309 | 0.025-0.028 | 0.365 | 0.467 | Yes (5 Blows) | 0.469-0.475 | Yes |
| 829 | | 0.476-0.485 | 0.295-0.310 | 0.027-0.032 | 0.369 | 0.469 | Yes (3 Blows) | 0.473-0.475 | No |
| 840 | | 0.475-0.483 | 0.295-0.302 | 0.025-0.028 | 0.372 | 0.470 | Yes (0 Blows) | 0.469-0.477 | Yes |
| 841 | | 0.475-0.484 | 0.295-0.308 | 0.026-0.030 | N/A | N/A | Yes | N/A | Yes |
| 842 | 17-4PH Steel at C Condition H925, 0.04-in. Wall | 0.478-0.482 | 0.295-0.305 | 0.027-0.029 | 0.373 | 0.471 | Yes (0 Blows) | 0.473-0.475 | Yes |
| 843 | | 0.470-0.480 | 0.294-0.305 | 0.024-0.029 | 0.373 | 0.470 | Yes (0 Blows) | 0.468-0.474 | Yes |
| 844 | | N/A | N/A | N/A | N/A | N/A | N/A | 0.474-0.477 | Yes |

condition, minor fuze ogive changes would be required. Some possibilities are listed and evaluated below:

| <u>Design Change</u> | <u>Evaluation/Comments</u> |
|--|--|
| • Heat treat and temper AISI 1144 ogive to Rockwell RC40 after machining. | This can be done without affecting percent elongation. Some part warpage may occur. |
| • Increase ogive wall thickness by blunting ogive. | Higher aerodynamic drag would result in increasing time of flight. |
| • Increase ogive wall thickness by designing fuze to intrude further into the projectile body. | Increasing wall thickness from 0.050 to 0.075 inch would cause the fuze to intrude 0.100 inch further into projectile body, reducing HEI content from 193 to 180 grains. |
| • Select alternate (stronger) ogive materials. | Low material cost and good machinability are very important. Leaded 4130 tool steel could be considered; however, a \$0.04 increase in ogive material cost would result. |
| • Various combinations of the design changes discussed above. | Best approach. |
| • Reduce ogive wall thickness to achieve superquick function against 0.125-inch aluminum at 3500 ft/s. | Superquick function more desirable than dud. Also resulting ogive streamlining would reduce time of flight (reduced drag and increased muzzle velocity). |

Body Assembly Integrity Softcatch Evaluation

The 10-shot body assembly integrity softcatch evaluation was authorized to explore causes for fuze sensitivity failures against 0.063-inch aluminum at 3500 ft/s, 0-degree obliquity (most units functioned on the second, 0.090-inch, target during pre-LAT testing). This type of sensitivity failure was also observed during Eglin AFB testing of the deliverables at 3500 ft/s, 0-degree obliquity on 0.063-inch aluminum. According to the computer program FUNDEL, the reduced ramp angle (25 degree) fuze equipped with

setback spring in place of the crushwasher should reliably function against 0.063-inch aluminum at 3500-ft/s, 0-degree obliquity conditions. This fuze (Mod XIV, Figure 6) functioned only one of five times against 0.063-inch aluminum as described under Fuze Sensitivity Evaluation.

The 10 cartridges were loaded with 40 grams of Olin WC870 propellant (3600-ft/s muzzle velocity) and fired into a long pneumatic recovery tube as shown in Figure 16. The tube was pressurized at 19 to 20 psig with air near the gun muzzle before firing. The end-cap metering orifice was adjusted so air pressure near the end of the tube was 10 to 11 psig. This pressure adjustment resulted in eight projectiles coming to rest after rebound in the tube near the blast vents (the other two units rebounded part way into the Mann barrel).

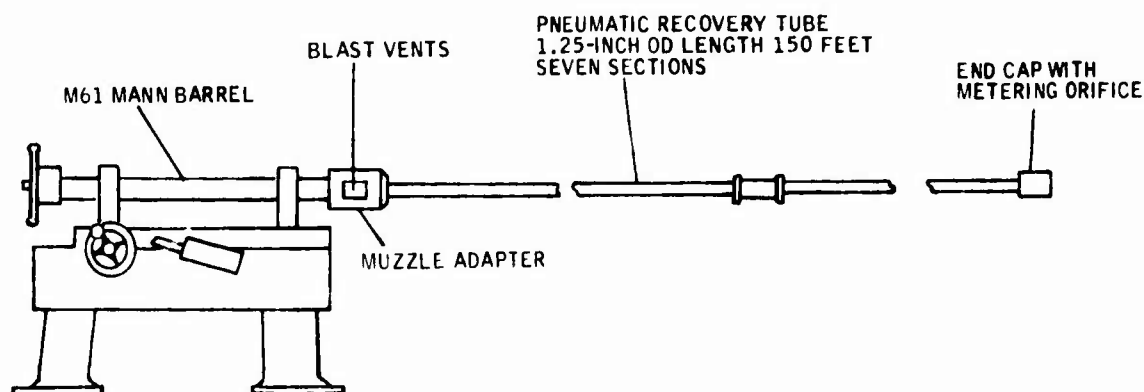

FUNCTIONAL DESCRIPTION

PROJECTILE EXITS FROM GUN AND ENTERS SMOOTH BORE TUBE (0.840-INCH ID)
GUN PRESSURE IS BLED FROM BLAST VENTS
DECELERATION IS ACCOMPLISHED BY AIR COMPRESSION

Figure 16. Softcatch Test Setup at Hopkins Indoor Range

No damage was done to projectile or ogive. The crushwashers collapsed properly, and measured thickness and maximum OD were 0.026 to 0.030 inch

and 0.485 to 0.488 inch, respectively. The piston spring remained attached to the body assembly after recovery and exhibited no apparent damage. No significant damage was noted on the aluminum lower body or piston assembly. Damage to the glass-filled nylon upper body is summarized as follows:

| Unit No. | Max. Dia. Opposite Lockweights ^a (in) | Condition |
|----------|--|---|
| 845 | 0.490 | Cracked near lockweights (parting line) |
| 846 | 0.486 | Cracked near lockweights (parting line) |
| 847 | 0.486 | Bulge near lockweights |
| 848 | 0.484 | Bulge near lockweights |
| 849 | 0.483 | Bulge near lockweights |
| 850 | 0.485 | Bulge near lockweights |
| 851 | 0.484 | Bulge near lockweights |
| 852 | 0.490 | Cracked near lockweights (parting line) |
| 853 | 0.485 | Bulge near lockweights |
| 854 | 0.484 | Bulge near lockweights |

^a This measured 0.482 on five new glass-filled nylon upper bodies which had not been fired and softcaught.

The above data show glass-filled nylon upper body deformation on the OD directly inline with the two spring-loaded rotor lockweights. The centrifugal force exerted by each 0.0555-gram lockweight assembly against the nylon upper body at 3500-ft/s muzzle velocity (spin = 2088 rev/s = 13119 rad/s) is

$$\begin{aligned}
 (F_c)_{3500 \text{ ft/s}} &= W^2 \bar{r} M_W = (13119)^2 \left(\frac{0.168}{12} \right) \left(\frac{0.0555}{(453.6)(32.17)} \right) \\
 &= 9.2 \text{ pounds (10.8 pounds at 3800-ft/s muzzle velocity)}
 \end{aligned}$$

A 9.2-pound lockweight force on an upper body produces a 0.01-inch dimple which disappears when the force is withdrawn. This essentially doubles the frictional force holding the body assembly aft as illustrated in Figure 17.

The computer program FUNDEL can now account for sensitivity failures against 0.063-inch aluminum at 3500 ft/s and 0-degree obliquity. Fuze Mod XIV should function if no upper body deformation occurs as shown in Figure 18(a). The effect of upper body deformation can be simulated by changing the friction coefficient, μ , between the ogive ID and body assembly from 0.1 to $\frac{4.39}{2.55} (0.1) = 0.172$ as shown in Figure 18(b). At a nominal firing pin-detonator clearance of 0.07 inch, firing pin energy is reduced from 2.40 in-oz to 0.34 in-oz (1.25 in-oz required for all-fire) as shown in Figure 18. The dimple caused by lockweight centrifugal force against the body may cause additional sensitivity problems because it occurs at the ogive ramp angle undercut.

It was concluded that upper body deformation resulting from high lockweight centrifugal force caused a significant reduction in sensitivity at the high velocity (3500 ft/s) - high spin rate - thin (0.053-inch) target impact condition. The deformation was severe enough to cause cracks along the glass-filled nylon upper body parting line in 3 of 10 units, and dimples (Figure 17) formed in the remainder. Only a minor design change in the lockweight assembly and/or upper body is required to correct the deformation (sensitivity) problem. If, for example, the lockweight spring thickness is reduced from 0.003 to 0.002 inch and the lockweight material is changed from steel to aluminum, the weight of the assembly is reduced from 0.0555 to 0.0250 gram, reducing centrifugal force at 3500 ft/s from 9.2 to 4.1 pounds. This can be done without changing the arming spin rate. A 0.001-inch spring with magnesium or Teflon[®] weight can reduce centrifugal force further to 2.4 pounds. Increasing the wall thickness of the upper body by 0.010 inch was also studied and is feasible. This was successfully evaluated on the XM714A2E1 25mm program for the U.S. Army.

THIS PROGRAM COMPUTES SELF DESTRUCT SPIN RATE AND THE CHANGE IN PROJECTILE VELOCITY REQUIRED TO TRIGGER THE XM714 TYPE OF BALL RELEASE MECHANISM AS A FUNCTION OF FUZE PARAMETERS, FIRING PIN ENERGY, DELAY FUNCTION TIME, AND PROJECTILE TRAVEL DISTANCE BETWEEN TARGET IMPACT AND DETONATION AS A FUNCTION OF FIRING PIN-DETONATOR CLEARANCE IS ALSO COMPUTED. A DETONATOR INITIATION TIME OF 50 MICROSECONDS IS ASSUMED AFTER IMPACT WITH THE FIRING PIN. ALSO, D MUST BE EQUAL TO OR GREATER THAN DX FOR ENERGY CALCULATIONS. ANGLE1, ANGLE2, ANGLE3, RN, SPIN! 25, 0, 0, 2, 2000,

WN, WR, WR! :000017, :00573, :0
 FSD, FPD, RKS, RKP! 2.4, .55, 9.2, 3.33
 FO, FB, FR, FH! :2, :.075, :.074-5, :.1 MI = 0.1
 YMAX, DX, E, YMIN! :21262, :02, :01, :1989
 VP, DV, DC, DC, CMAX! 3500, :16.2, :04, :01, :101

TRIGGER VELOCITY(FPS)= 7.20627369
 SELF DESTRUCT SPIN RATE(RPS)= 1292.93212890

| F.P. (INCH) | F.P. ENERGY (IN-OZ) | DELAY TIME (MICROSEC) | DELAY DISTANCE (INCH) |
|----------------|---------------------------|-----------------------------|-----------------------------|
| 0.04000000 | 3.21330214 | 267.96484375 | 11.21210838 |
| 0.05000000 | 2.96280718 | 329.97125244 | 13.79425049 |
| 0.05999999 | 2.69242430 | 394.77366475 | 16.50328445 |
| 0.06999999 | 2.40214391 | 463.05535689 | 19.35774994 |
| 0.08000000 | 2.04199524 | 535.76566914 | 22.37736938 |
| 0.09000000 | 1.76294811 | 614.30395508 | 25.68061066 |
| 0.10000001 | 1.41201425 | 700.89172363 | 29.30036163 |

MORE RUNS: 1.=YES, 2.=NO! 1.

(n)
 No Upper
 Body
 Deformation

ANGLE1, ANGLE2, ANGLE3, RN, SPIN! 25, 0, 0, 2, 2000,

WN, WR, WR! :000017, :00573, :0
 FSD, FPD, RKS, RKP! 2.4, .55, 9.1, 3.33
 FO, FB, FR, FH! :1, :.075, :.075, :.172 MI = 0.172
 YMAX, DX, E, YMIN! :21262, :02, :01, :1989
 VP, DV, C, DC, CMAX! 3500, :16.3, :04, :01, :101

TRIGGER VELOCITY(FPS)= 9.28593626
 SELF DESTRUCT SPIN RATE(RPS)= 1088.15126718

| F.P. (INCH) | F.P. ENERGY (IN-OZ) | DELAY TIME (MICROSEC) | DELAY DISTANCE (INCH) |
|----------------|---------------------------|-----------------------------|-----------------------------|
| 0.04000000 | 2.03871344 | 287.33593750 | 12.01190567 |
| 0.05000000 | 1.39291389 | 369.53570557 | 15.44821930 |
| 0.05999999 | 0.92923628 | 469.15466309 | 19.61272812 |
| 0.06999999 | 0.34465170 | 609.47363281 | 25.47858729 |
| 0.08000000 | 0.00000000 | | |
| 0.09000000 | 0.00000000 | | |
| 0.10000001 | 0.00000000 | | |

MORE RUNS? 1.=YES, 2.=NO! 2.

(n)
 With Upper
 Body
 Deformation

STOP. DONE

Figure 18. Calculated Fuze Mod IV Sensitivity (3500-ft/s, 0-degree obliquity impact against 0.063-inch 2024-T3 aluminum)

500-Meter Function Demonstration

The 20-shot 500-meter function demonstration was conducted on 4 August. Eglin AFB sent 20 of the deliverable projectiles back to the contractor for this test. The test involved firing the projectiles at maximum velocity against 0.125-inch 2024-T3 aluminum targets placed 500 meters downrange at 0-degree obliquity. Instrumentation included velocity coils and LOCAM color movies behind the target as shown in Figure 19.

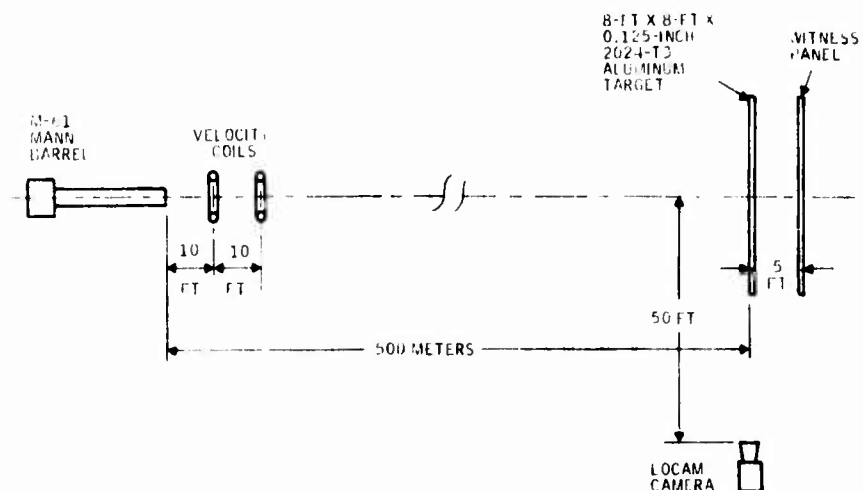

Figure 19. 500-meter Function Demonstration Test Setup

Initial conditions were as follows:

- Fuze -- XM714A3 Mod XI as defined in Figure 1
- Projectile -- 1226-grain polyarylene-banded thin-wall projectile containing 193 grains of LCA 1 HEI mix (Figure 2)
- Cartridge -- M103 case with 610 grains (.5 gram) of Olin WC870 ball propellant (Figure 3)

- Muzzle Velocity -- 3600 ft/s measured
- Range -- 500 meters
- Target -- 0.125-inch 2024-T3 aluminum at 0-degree obliquity
- Impact Velocity -- 2500 ft/s (estimate)

Results were as follows:

- 17 for 17 delay functions on 0.125-inch 2024-T3 aluminum (14 high-order and 3 low-order)
- 3 for 3 delay functions on 2-inch oak backstep (missed aluminum target)
- Standard deviation of radius (accuracy) measured at 0.9 mil (gun moved so actual accuracy < 0.9 mil)

These results are considered very encouraging because it is believed that this type of test more nearly simulates air-to-air combat impact conditions.

Performance Analysis

With reference to the ADTC Eglin Air Force Base test results in Figures 12 through 14, the causes of the High Failure Rate Area and Reliable Second Impact Function Area may now be explained.

High Failure Rate Cause -- This area is caused by the ogive deformation as the fuze passes through the target. On low-obliquity targets, the fuze ogive is forced or swaged in, reducing the piston bore and body bore diameters and thus locking the assembly in place and preventing operation. This action is not as prevalent at higher-obliquity targets since the swaging action is nonsymmetrical. Several approaches can be taken to alleviate the problem.

The wall thickness can be increased by moving the internal elements aft and taking the slight loss in HE in the projectile. This, together with heat treatment of the ogive, should allow penetration of the target without serious deformation. If heavier targets are encountered, the problem may reappear. The other approach may be to thin the sections so that the firing pin is forced into the detonator on heavy targets. This would give superquick rather than delay function but would give an HE event. This would assure firing on all target thicknesses.

Reliable Second-Impact Function -- This area may be good technically. After penetration of a light skin, a heavier structure must be hit to assure function, and this may produce maximum effects. At the present time, computer analysis indicates the fuze should function in the areas where it presently needs a second impact to function. Softcatch fuze tests have revealed that the probable cause of this is a material failure or excessive yielding in the plastic, upper body caused by the rotor lockweights. This yield allows the lockweight to act as a second body-locking feature and increases the velocity change required to move the body assembly forward with sufficient energy to fire the detonator. Several things can be done to eliminate the problem through design. These include:

- Change from steel to aluminum lockweights and modify lockweight spring.
- Modify plastic upper body design to increase section so that deformation doesn't occur or is minimized.

SECTION V
COST TO PRODUCE

The methodology, assumptions, rationale, cost curves, and working papers for the Cost to Produce Study were submitted. These data are proprietary to the contractor and should not be disclosed outside the Government or duplicated. The following high-volume unit costs are projected based on a unit product cost of \$0.899 for 12 million units (1975 dollars) and an 82 percent learning curve.

| <u>Quantity (millions)</u> | <u>Cumulative Quantity (millions)</u> | <u>Unit Cost (dollars)</u> |
|----------------------------|---------------------------------------|----------------------------|
| 12.0 | 34.4 | 0.899 |
| 25.0 | 61.4 | 0.770 |
| 25.0 | 86.4 | 0.683 |
| 25.0 | 111.4 | 0.628 |
| 25.0 | 136.4 | 0.589 |
| 25.0 | 161.4 | 0.558 |
| 25.0 | 186.4 | 0.534 |
| 25.0 | 211.4 | 0.514 |

SECTION VI
CONCLUSIONS AND RECOMMENDATIONS

The following discussion is based on the work described in this document. The XM714A3 Mod XI fuze and projectile design referred to is the deliverable item defined in Figures 1 and 2.

CONCLUSIONS

The key objectives of the program, as defined in the last paragraph of Section I, were met with the deliverable items, i. e. :

- A function delay of 10 ±4 inches (9 inches, nominal delay required) was demonstrated at 0- to 80-degree obliquity, 2500- to 3500-ft/s impact velocity against 0.06- to 0.125-inch 2024-T3 aluminum targets.
- The fuze was packaged within the 1.2-inch-long ogive profile.
- Bore safety and reliable arming within 100 feet was provided.
- Selected MIL-STD-331/MIL-STD-810B safety was demonstrated.
- No self-destruct and no function against the simulated rain target (0.0159-inch 2024-T3 aluminum) was demonstrated.
- Projectile length, protrusion, weight, and charge-mass ratio (C/M) requirements were met or exceeded.

| <u>Parameter</u> | <u>Required</u> | <u>Actual</u> |
|-----------------------|-----------------------|---------------|
| Projectile Length | 3.05 - 3.40 inches | 3.05 inches |
| Projectile Protrusion | 2.600 inches, maximum | 2.600 inches |
| Projectile Weight | 1200 - 1300 grains | 1226 grains |
| C/M | 0.30, minimum | 0.342 |

- A total of 373 rounds was evaluated as compared to a requirement to test 175 rounds, minimum.
- Documentation was provided per DD Form 1423.
- Five-hundred XM714A3 fuzed projectiles were shipped on 14 May as compared to a contract requirement date of 6 May 1976.

The XM714A3 delay function fuze and thin-wall plastic-banded projectile have undergone extensive gun testing, starting 2 years ago with 40 contractor-sponsored tests. During the subject contract, an additional 373 tests were conducted by the contractor, and 307 tests were conducted by Eglin AFB, bringing total tests to 720 units. Over one-half (397 units) of these tests were conducted on the XM714A3 Mod XI deliverable design. The overall performance of the fuzed projectile is best characterized by the five-unit firings at each of 54 impact conditions [3 velocities (2500, 3000, and 3500 ft/s) x 3 targets (0.063-, 0.090-, and 0.125-inch 2024-T3 aluminum) x 6 obliquities (0, 20, 40, 60, 70, and 80 degrees)] done by ADTC Eglin Air Force Base as summarized in Section IV and Figures 12 through 14. Fuze and projectile structural integrity is also best characterized by the Eglin tests wherein all required impact conditions and some desired impact conditions were survived intact. The contractor's limited tests on XM714A3 Mod XI fuzes were also successful, as summarized in Table 16 for LAT and post-delivery tests. These tests were generally conducted at the more severe 3500-ft/s and greater velocity conditions.

TABLE 16. LAT AND POST-DELIVERY TEST SUMMARY

| Muzzle Velocity (ft/s) | Target Range | 2024-T3 Target Thickness/Obliquity | Results (second target - 0.090 in.) | | |
|--|--------------|------------------------------------|-------------------------------------|--------------------|--|
| | | | No. of Shots | No. of Armed Fuzes | Delay Function |
| 2500 | 100 ft | 0.090 in /0 deg | 10 | 10 | 10/10 |
| 3500 | 100 ft | 0.063 in /0 deg | 5 | 5 | 0/5 (4 second target) 1 no function |
| 3500 | 100 ft | 0.080 in /0 deg | 5 | 5 | 3/5 (2 second target) |
| 3500 | 100 ft | 0.090 in /0 deg | 16 | 16 | 15/16 (1 second target) |
| 3500 | 100 ft | 0.090 in /0 deg | 4 | 4 | 4/4 (2 low-order) |
| 3700 | 500m | 0.090 in /30 deg | 17 | 17 | 17/17 (3 low-order) |
| 3700 | 500m | 2-in oak | 3 | 3 | 3/3 |
| Totals: 52/60 = 87 percent on first target 59/60 = 98 percent on first or second target | | | | | |

Projectile accuracy and polyarylene rotating band retention was also monitored during the program at several ranges at 3700-ft/s muzzle velocity with results as follows:

| <u>Accuracy</u> | | | | | |
|-----------------|------------|--------------|-----------------------|----------------------|-----------------|
| | <u>Qty</u> | <u>Range</u> | <u>Av Mean Radius</u> | <u>Std Deviation</u> | <u>Comments</u> |
| | 6 | 100 ft | 1.10 | -- | Trailer mount |
| | 4 | 534 ft | 1.1 | -- | Trailer mount |
| Most Valid Test | 15 | 1707 in | 0.86 | 0.81 | Rigid gun mount |
| | 20 | 500 meters | 1.19 | 0.94 | Gun moved |

Rotating band retention was demonstrated after 28-day T&H exposure (Test No. 105 of MIL-STD-331) in the above listed 1707-inch accuracy test (see Figure 15). Thin-wall projectile body integrity at twice the required HEI

loading pressure (60 kpsi) and 60-kpsi gun launch were demonstrated during the program. Projectile explosive content (lethality) was also quite high at 193 grains of LCA 1 HEI mix.

Computerized math models of fuze behavior during target impact were continuously exercised and updated on the basis of experimental data. Since these models correlate with experimental observations, the number of tests required to explore further fuze modifications during follow-on engineering development can be reduced, thereby reducing development costs.

The deliverable fuze design uses most of the parts common to the standard XM714A2 fuze except for a simplified one-piece (rather than four-piece) ogive, a crushwasher (rather than setback spring), and a two-piece base and slider. The ogives were fabricated from a very producible AISI C1144 carbon steel. The cost-to-produce study, summarized in Section V, shows a unit product cost as low as \$0.514 each in 1975 dollars after a production of 186,400,000 units. This should compare favorably with the M505A3 fuze in which at least 500,000,000 units have been produced.

RECOMMENDATIONS

From the ADTC Eglin Air Force Base test results in Figures 12 through 14, it is apparent that most of the failures occurred at 3500-ft/s impacts against thin (0.063-inch) and thick (0.125-inch) aluminum at low angles of obliquity. Results at 2500 and 3000 ft/s (Figures 12 and 13) were very good. Based on these observations, the following recommendations are made with respect to any future development activity:

- Determine if the 3500-ft/s impact condition is a realistic condition which will occur during air-to-air combat. An upper limit of 3000 ft/s may be more realistic as discussed in Section IV and presented in Table 13.

- If it is determined that improved performance at 3500 ft/s is required, then:
 - Fuze ogive deformation against 0.125-inch aluminum must be reduced by increasing wall thickness and heat-treating the ogive. This should eliminate the high failure rate area shown in Figure 14.
 - The glass-filled nylon upper body wall thickness should be increased and/or lockweight assembly mass reduced to reduce friction as illustrated in Figure 17 and improve first-target impact delay function rate against thin (0.063 inch) targets shown in Figure 14.
- Incorporate two rather than one nylon ball and reduce ramp angle from 45 degrees to 15 to 25 degrees.
- Consider reducing firing pin-detonator clearance from 0.0745 \pm 0.0185 to 0.0695 \pm 0.0185 inch.
- Add a 0.20-inch-diameter hole through the pad to reduce the chance of low-order function.
- Consider replacing the crushwasher with a setback spring. This will further improve sensitivity and permit the use of a heavier piston spring for reliable arming. Also, the base slide would no longer be required, causing a reduction in product unit cost. The base slide may also have contributed to certain low-order target functions; i. e. , no low-order functions were noted in 52 tests of fuzes without base slides (reference Mods I, II, III, and XIV). The use of a setback spring, however, will provide self-destruct beyond 4000 meters slant range.
- Consider blunting the ogive and adding a windscreen to increase projectile ΔV during target perforation to increase sensitivity.

The recommended design changes are incorporated into two different fuze designs (Mod XV and XVI) and compared to the deliverable design (Mod XI) in Table 17. Mod XVI differs from Mod XV in that the crushwasher is replaced with a setback spring. This will further improve sensitivity and permit the use of a heavier piston spring for reliable arming. Also, the base slide would no longer be required, causing a reduction in product unit cost. The base slide may also have contributed to certain low-order target functions; i. e., no low-order functions were noted in 52 tests of fuzes without base slides (reference Mods I, II, III and XIV). The use of a setback spring, however, will provide self-destruct beyond 4000 meters slant range. For this reason, Mod XV was also recommended (see Table 17).

TABLE 17. RECOMMENDED FUZE DESIGN CHANGES

| Parameter Definition | Deliverable Design Mod XI | Engineering Development Designs | |
|-------------------------------------|------------------------------|------------------------------------|------------------------------------|
| | | Mod XV | Mod XVI |
| Lockweight Assembly | Standard Heavyweight | Lightweight | Lightweight |
| Upper Body Wall Thickness (in) | 0.015 | 0.025 | 0.025 |
| Ogive Hardness | RC-30 | RC-40 ¹ | RC-40 ¹ |
| Ogive Configuration | | Blunt (odd windscreens) | Blunt (odd windscreens) |
| Ogive Wall Thickness (in) | 0 | > 0.05 | > 0.05 |
| Balls | 1 - Nylon | 2 - Nylon | 2 - Nylon |
| Ramp Angle (deg) | 15 | 15 | 25 |
| Firing Pin-Defonator Clearance (in) | 0.0745 ± 0.0185 | 0.0695 ± 0.0185 | 0.0695 ± 0.0185 |
| Crushwasher | Annealed 2024-0 | Annealed 2024-0 | Setback spring |
| Piston Spring Force (lb) | 0.55 | 0.55 | 1.5 |
| Base Slide | Yes | Yes | Eliminate |
| Body Assy. Effective Weight (lb) | 0.0105 | 0.0105 | 0.00573 |
| Pad | Std XM714A2 | Modify with 0.2-inch-diameter hole | Modify with 0.2-inch-diameter hole |

APPENDIX A
FINAL HAZARD ANALYSIS REPORT

This final hazard analysis was prepared in response to DD1423 Data Item A005 of Contract F08635-76-C-0139. As indicated in the System Safety Program Plan, the hazard analysis tasks for this 6-month program included the following:

- Review of XM714A3 safety features against the requirements of MIL-STD-1316A, Criteria for Fuze Design Safety.
- Revision of safety fault tree diagrams on the XM714 fuze to reflect the XM714A3 changes. These diagrams illustrate the events and conditions that would be necessary for explosive function to occur during (1) the gun chambering cycle, (2) gun firing (setback) and (3) through muzzle exit.
- Examination of XM714 fuze safety aspects that could be affected by the changes planned for the delay version, XM714A3.
- Submittal of the above items in this document, thereby fulfilling the data item A005 requirement.

DESCRIPTION OF XM714A3 DELAY FUZE

The XM714A3 fuze is shown in Figure A-1. This inertial delay function fuze is basically an XM714A2 PDSF fuze currently being developed by the contractor under contract with the U.S. Army for the 20mm M56 HEI round. It utilizes the basic XM714A2 parts in the body and spring assembly, piston assembly, and lead cup assembly.

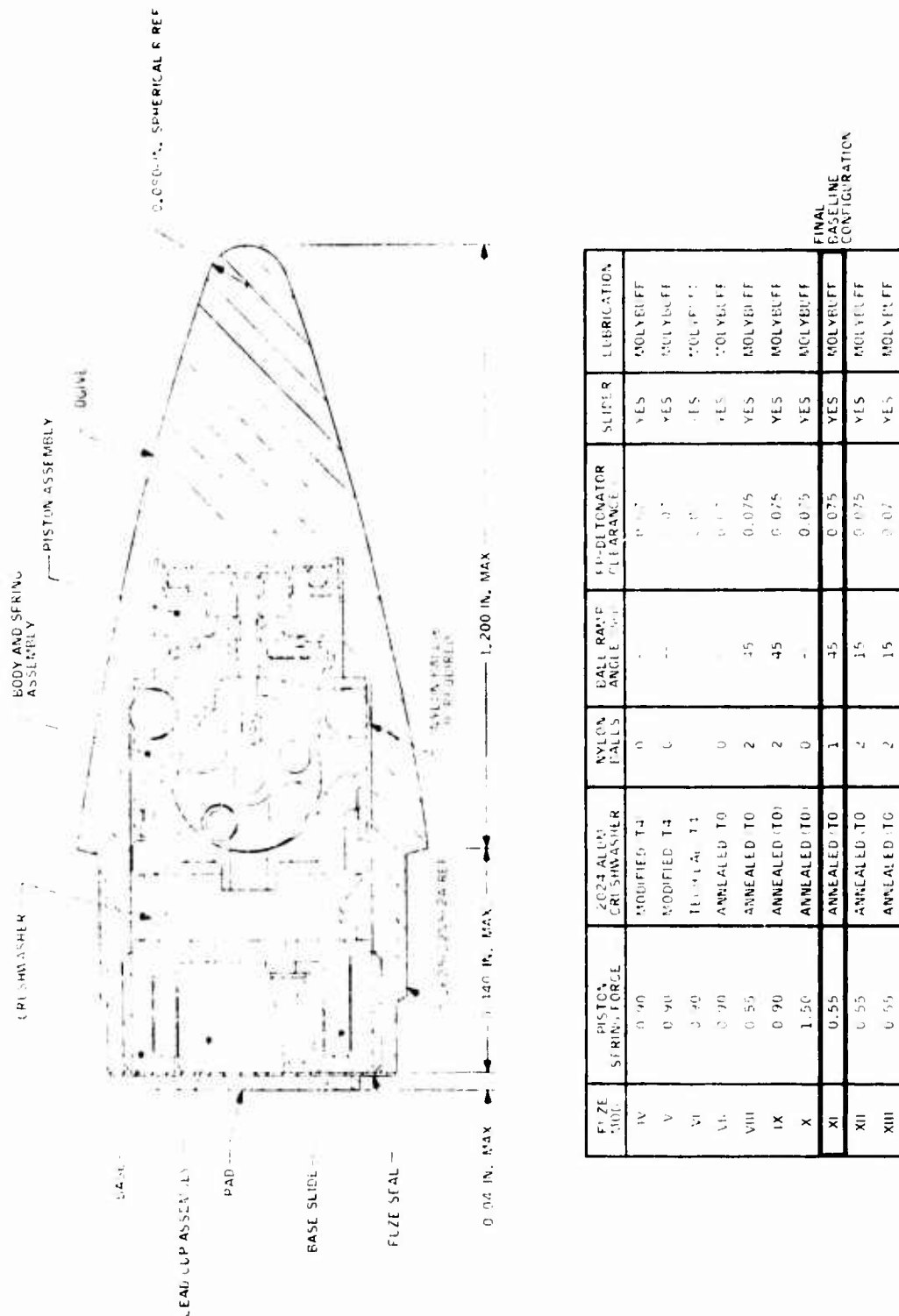

Figure A-1. XM714A3 Delay Function Fuze Final Baseline

The XM714A3 delay function fuze is illustrated in its safe, setback, armed, and detonation operational modes in Figure A-2. The fuze is subjected to high spin and acceleration as the projectile travels down the barrel. These forces cause both the piston assembly and body assembly to setback, permanently deforming the crush washer. Air originally in the bottom of the fuze is displaced through ports into the chamber above the piston. High spin forces occur almost simultaneously with the setback force, causing the centrifugal lockweights to move against their springs. This removes one constraint on the rotor in the safe position. Centrifugal force also causes the rubber piston seal^a to spin out against the inner bore of the ogive to provide the necessary sealing of air.

As the projectile exits the muzzle, the acceleration force dissipates and the piston is free to move forward under forces exerted by the piston spring. A finite time that can be controlled is required for the piston to move forward fully since air must move through the porous metal restrictor. This action provides an arming delay of 5 to 50 meters over a temperature range from -60° to +155°F in the 20mm projectile environment.

When the piston reaches the forward position, the firing pin withdraws from the rotor and allows it to rotate to the armed position. Centrifugal force acting on roller weight causes it to move into a groove and lock the rotor in the armed position. The fuze is fully armed when the detonator is in line with the firing pin and the lead assembly.

Detonation (see bottom view of Figure A-2) occurs when the armed fuze encounters the following:

- Delay high-order function on soft (aluminum) targets.

^a During the feasibility demonstration and 500-unit delivery, fuzes were fabricated without rubber piston seals allowing arming to occur within 100 feet of the muzzle, as required.

SAFE

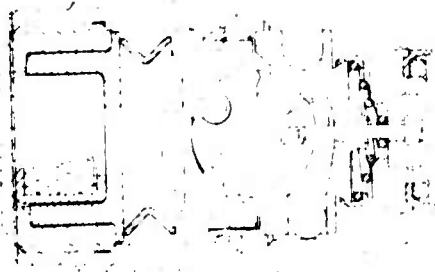

SETBACK

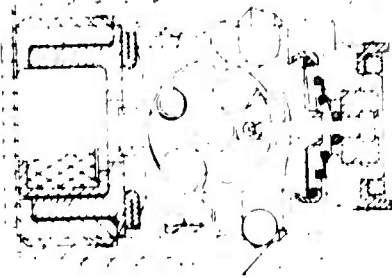

ARMED

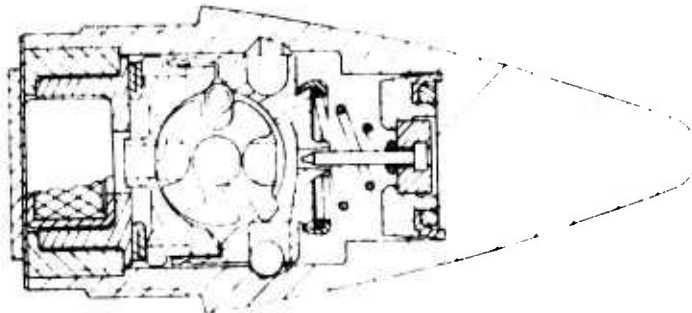

DETONATION

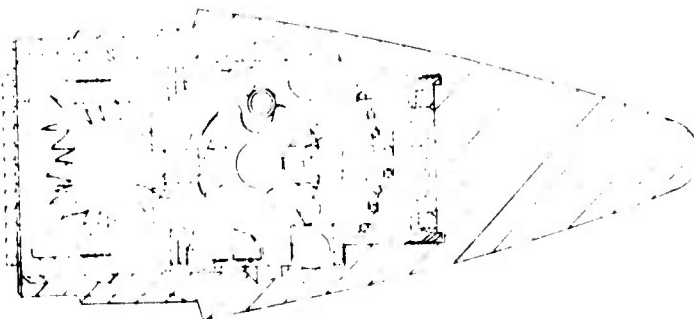

Figure A-2. Fuze Operational Modes

- Superquick (ogive crush action) detonation on hard targets.
- Graze function.

This hazard analysis concerns the period prior to intended fuze arming.

COMPLIANCE WITH MIL-STD-1316A SAFETY REQUIREMENTS

A review was made of applicable safety requirements of MIL-STD-1316A and design safety features of the XM714-A3 fuze. Results of this review are shown in Table A-1.

MIL-STD safety testing involved evaluating five units each of eight MIL-STD safety tests with results as follows:

- Jolt (Test No. 101 of MIL-STD-331) - Five units were inspected and all passed the test.
- Jumble (Test No. 102 of MIL-STD-331)- Three of five units passed. The other two units came apart in the jumble box, i. e. , base unscrewed from ogive as defined in the assembly drawing (Figure A-1). Application of an adhesive to the base threads or staking the ogive-base threads after assembly would prevent this problem. On the deliverable units, the fuze is assembled with sealing and locking compound applied to the fuze/projectile threads. Unscrewing of the base cannot occur under these conditions.
- Waterproofness (Test No. 108 of MIL-STD-331) - All five units passed. Two were disassembled and inspected and three were gun tested with functions on either the first or second target.
- Five-Foot Drop (Test No. 111 of MIL-STD-331) - All five units

TABLE A-1. MIL-STD 1316A COMPLIANCE

| MIL-STD-1316A Statements | Compliance | | Comments |
|---|------------|----|---|
| | Yes | No | |
| <p>4. REQUIREMENTS</p> <p>4.1 Design.-The following features, procedures, or controls shall be incorporated into the design of fuzes covered under the scope of this document.</p> <p>4.1.1 Explosive Train Interruption (Tri-Service).-When the explosive train includes primary explosives more sensitive than those listed in Paragraph 4.1.2, at least one interrupter shall separate the primary explosives from the main charge before arming. Explosive train interruption will be positioned so as to isolate primary explosives using at least one interrupter (carrier, shutter, slider, rotor) to separate this explosive from the lead and booster explosive until the fuze arms. The interrupter shall mate positive mechanical engagement. Early in the design, the effectiveness of interruption shall be determined by techniques described in:</p> <p>a. MIL-STD-331 (Tri-Service)</p> <p>b. MILC Report 6666 (Navy-Air Force)</p> <p>4.1.2 Explosive Sensitivity (Lead and Booster Explosives).-The following explosives are the only ones permitted in a position leading to the initiation of the main charge without interruption when the fuze is in the safe condition.</p> <p>Explosive Specification</p> <p>Tetryl Composition A-3 (Modified) Composition A-4 Composition A-5 (Class 1) RDX Comp CH6 Tetryl, Pellets PBXN-5 DIPAM HNS Type 1 or Type 2 or Gr A</p> <p>4.1.3 Alternate Lead and Booster Explosives.- If it is desired to use explosives other than those listed in 4.1.2, specific written approval is required from the cognizant technical authority.</p> | X | | <p>Motor is locked in the safe position with lock weights set and the firing pin until fuze is armed. Expect to comply with MIL-STD-331 tests based on previous AM714 test data. Testing to be performed per project test plan.</p> |
| <p>4.1.2 Explosive Sensitivity (Lead and Booster Explosives).-The following explosives are the only ones permitted in a position leading to the initiation of the main charge without interruption when the fuze is in the safe condition.</p> <p>Explosive Specification</p> <p>Tetryl Composition A-3 (Modified) Composition A-4 Composition A-5 (Class 1) RDX Comp CH6 Tetryl, Pellets PBXN-5 DIPAM HNS Type 1 or Type 2 or Gr A</p> <p>4.1.3 Alternate Lead and Booster Explosives.- If it is desired to use explosives other than those listed in 4.1.2, specific written approval is required from the cognizant technical authority.</p> | X | | <p>Compliance is expected prior to production. A program is underway to switch from the current MIL-STD-331 to PBXN-5 in the lead cup assembly. The PBXN-5 leads must be fully evaluated prior to the change.</p> |
| | | | See above. |

TABLE A-1. MIL-STD 1316A COMPLIANCE (Continued)

| MIL-STD-1316A Statements | Compliance | | Comments |
|--|------------|----------|--|
| | Yes | No | |
| <p>4.2 Initiators "in-line".-Initiators "in-line" (i.e., not followed by explosive train interruptions) shall not be used in fuzes, except as allowed by paragraph 4.2.2 below, even though explosives employed are those listed in 4.1.2. Where electrical type initiators or detonators are employed, a positive means (e.g., shorting or switching) of preventing fuze detonation prior to fuze arming shall be provided.</p> <p>4.3 Fuze Safety System</p> <p>4.3.1 The safety system of fuzes shall comprise at least two independent safety features, each of which is capable of preventing unintentional arming and unintentional detonation of the main charge of the munition. Each of these safety features shall be actuated by at least one separate environmental force. Each safety feature shall employ an independent source of arming energy. One feature shall provide safe separation. One of the mechanisms shall depend upon sensing a post launch environmental condition, which unlocks or arms the interrupted train. A launch signal may be used to initiate one of the safety features.</p> <p>4.3.2 (Army) If the primary explosive material, which is more sensitive than the lead and booster explosives (see 4.1.2) are housed in the interrupter, a single interrupter locked by the two independent safety features, is acceptable since an omission of the interrupter shall not result in a safety failure. If the element containing the primary explosive is mounted "in-line" and if the omission of a single interrupter could lead to a safety failure, the design shall include two interrupters, each of which shall respond to a different environmental force, or both interrupters shall each respond to two environmental forces.</p> <p>4.4 Safe-Arm Indication for Bomb Fuzes (Tri-Service).-In addition to those requirements specified in 4.5 below, bomb fuzes must possess a feature(s) which assure a positive means of determining the safe or armed condition of the fuze before and after installation into the bomb.</p> <p>4.5 Safe-Arming Indication (Navy-Air Force).-One or more of the following options shall be selected or combined in the fuze design:</p> | <p>X</p> | <p>X</p> | <p>Not Applicable.</p> <p>Spin environment is required to remove lock weights from the rotor. Acceleration (set back), followed (post launch) by forward movement of the piston assy by the piston spring, must occur (during spin) for the firing pin to unlock the rotor. Safe separation is provided by restricting forward piston movement with a porous metal air flow restrictor.</p> <p>Rotor is locked by two lock weights plus the firing pin.</p> <p>Not applicable.</p> |

TABLE A-1. MIL-STD 1316A COMPLIANCE (Concluded)

| MIL-STD-1316A Statements | Compliance | | Comments |
|--|-----------------|----|---|
| | Yes | No | |
| <p>4.5.1 A feature which assures a positive means of determining safe or armed conditions prior to installation into the munition.</p> <p>4.5.2 A feature which prevents installation of an armed, assembled fuze into the munition.</p> <p>4.5.3 A feature which prevents assembling the fuze in the armed or partially armed condition. This option is sufficient only if the fuze contains at least one arming mechanism which requires a unique environmental force for operation which precludes accidental or inadvertent arming from handling to launch.</p> <p>4.5 Manual Arming (Navy-Air Force).-If after installation in the munition, the fuze could be armed manually, or by any method other than by launching the munition, a feature which allows observation or permits ready determination of the safe or armed condition of the fuze after it has been installed in the munition must be present.</p> <p>4.7 Arming and Reset (Navy-Air Force).-If arming and reset of the assembled fuze in tests is a normal procedure in manufacturing, inspection, or at any time prior to assembly into the round, the conditions of option 4.5.3 above are not sufficient and the requirements of 4.5.1, 4.5.2 or 4.6 must be met.</p> <p>4.8 Safety System Failure Rate (Tri-Service).-The system safety failure rate of a new fuze shall be determined by performing a Safety Failure Analysis. (A method is described in Paragraph 6.3.2).</p> | See Comments | | <p>it is possible to visually detect an armed rotor through the fuze output hole prior to lead installation.</p> <p>The rotor has a projection that fits into a recess in the body. The firing pin also projects into a rotor cavity.</p> <p>Not applicable.</p> <p>Not expected to be applicable. If necessary to more easily check rotor position (through output hole) a colored dot could be added on the rotor.</p> <p>Fault tree analysis to date indicates no single point failure modes in the mechanism.</p> |
| | See Comments | | |
| | x | | |

were gun tested with three functioning properly. The remaining two units were partially armed on impact with the first target. These units were dropped nose down and 45 degree nose down.

The partial arming failures were believed caused by crushwasher spring back (washers were not annealed) which is not related to the Five-Foot Drop Test.

- Static Detonator Safety (Test No. 115 of MIL-STD-331) - All five units passed the test at ambient temperatures.
- Salt Fog (Method 509 of MIL-STD-810B) - All five units passed the test. Two were disassembled and three were gun tested.
- Vibration (Method 514.1 of MIL-STD-810B) - All five units were gun tested with four functioning properly and one arming failure. The arming failure was attributed to crushwasher spring back and not vibration effects.
- Temperature/Humidity/Altitude (Method 518 of MIL-STD-883B) - All five units passed. Two were disassembled and inspected and three were gun tested with proper functions on the second target.

All of the above discussed 19 gun tests on MIL-STD safety test units were conducted at 3500 ft/s, 0 degree obliquity, against 0.063-inch 2024-T3 aluminum targets with a 0.090-inch second target placed 5 feet away. As summarized above, 3 units delay functioned on the first target, 13 functioned on the second target, and 3 were failures (2 partial arms plus 1 arming failure - believed caused by crushwasher springback). Annealing the crush washer to condition 2024-0 corrected this problem

FAULT TREE ANALYSES/DIAGRAMS

Fault tree symbology is defined in Figure A-3. The fault tree safety analyses/diagrams for the XM714A3 Delay Fuze are presented in Figures A-4, A-5 and A-6, covering the gun chambering, gun firing, and exit time periods. These fault tree analyses/diagrams were modified from those available on the XM714 (Std) fuze.

In conducting these fault tree analyses, the following general groundrules were utilized.

- The fuze complied with the applicable MIL-STD-331 criteria for test passing -- specifically the rough handling and static detonator safety tests.
- If a body assembly with an armed rotor (aligned detonator) is installed in the fuze, the firing pin will initiate the detonator during subsequent fuze assembly operations.

With the exception of the lead cup assembly primary and secondary failures, there were no single-point failures (i. e., a single component failure or defect mode) identified in the analysis which could result in a safety failure of the fuze during the life cycle phases stated.

CONCLUSIONS/RECOMMENDATIONS

A general conclusion of the hazard analysis efforts to date is that the XM714A3 delay fuze meets all of the fuze design safety criteria appropriate for the intended application.

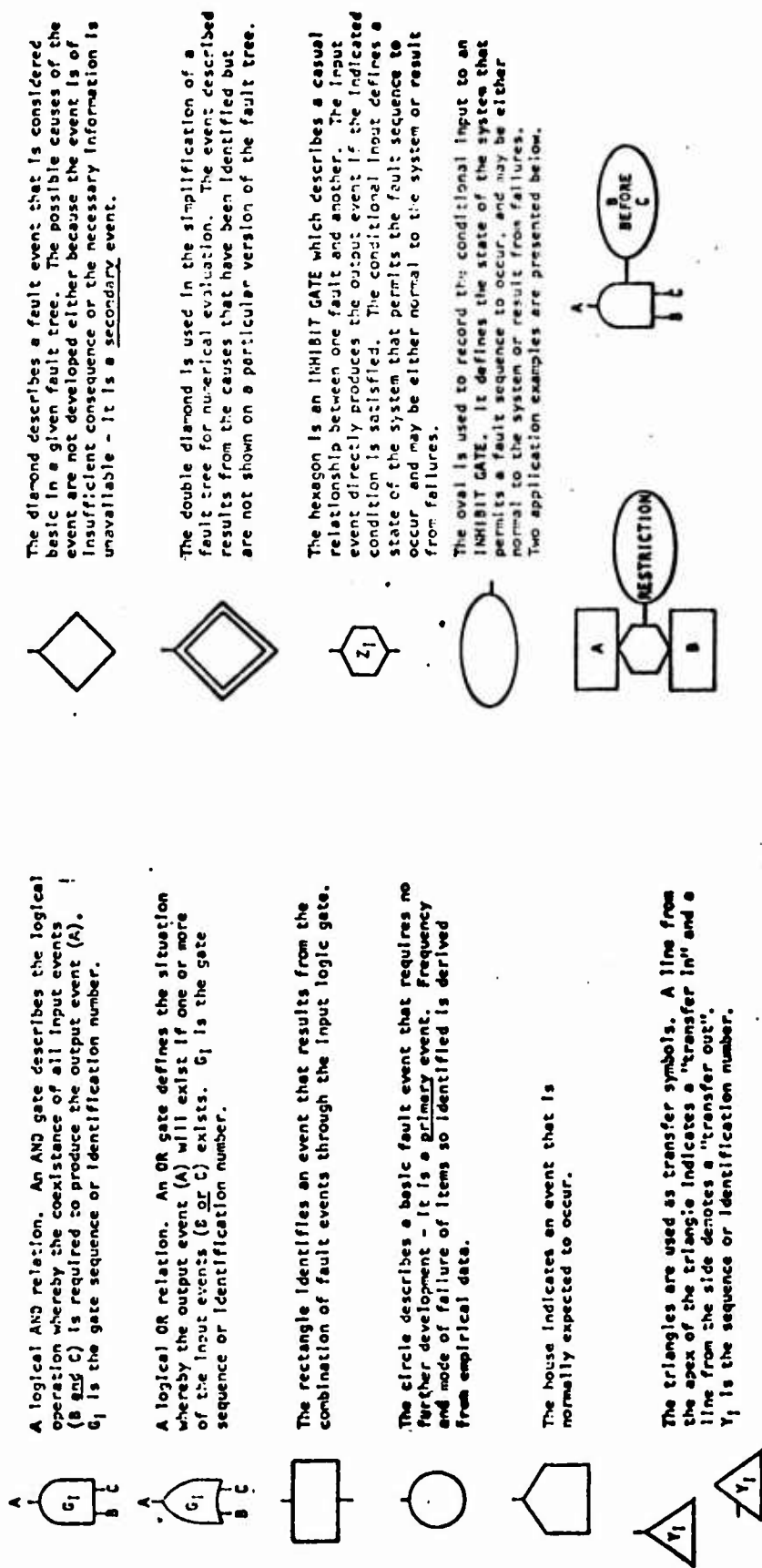

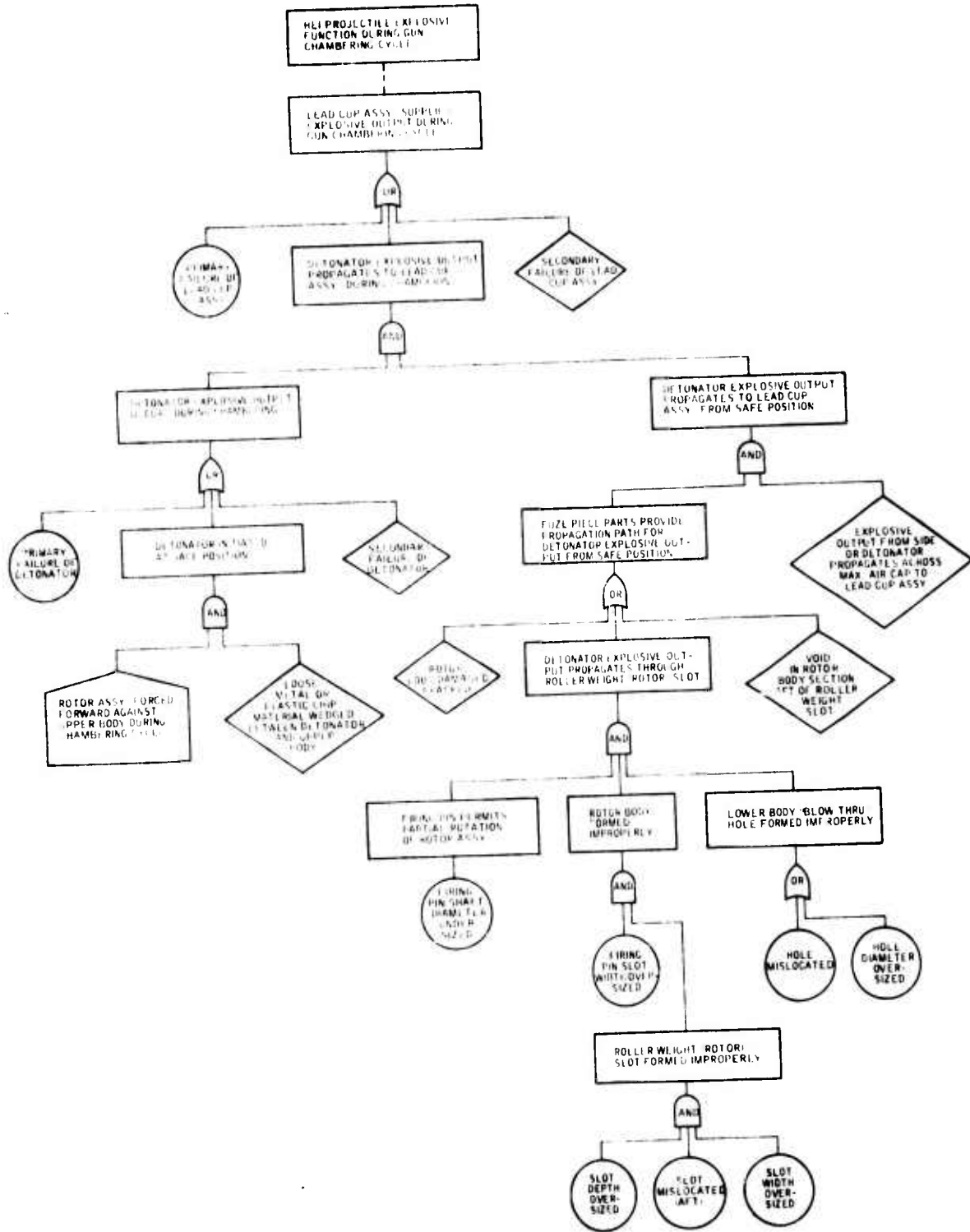

Figure A-4. Gun Chambering Cycle Fault Tree

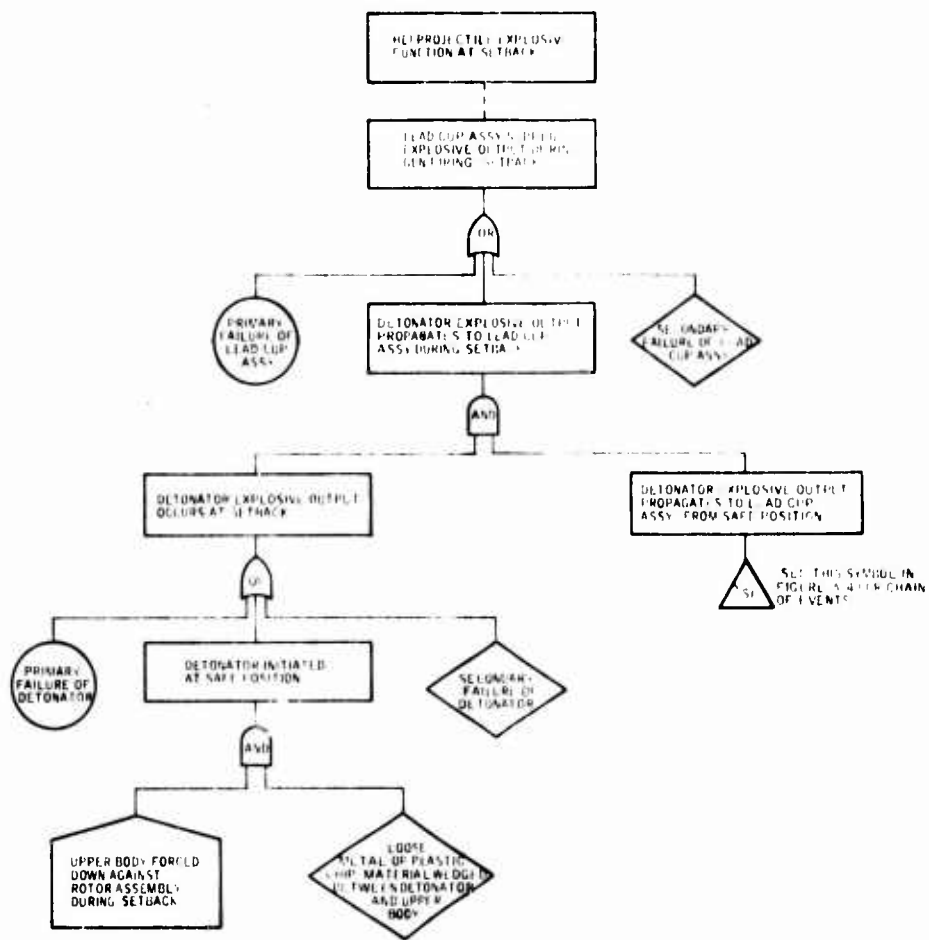

Figure A-5. Gun Firing (Setback) Fault Tree

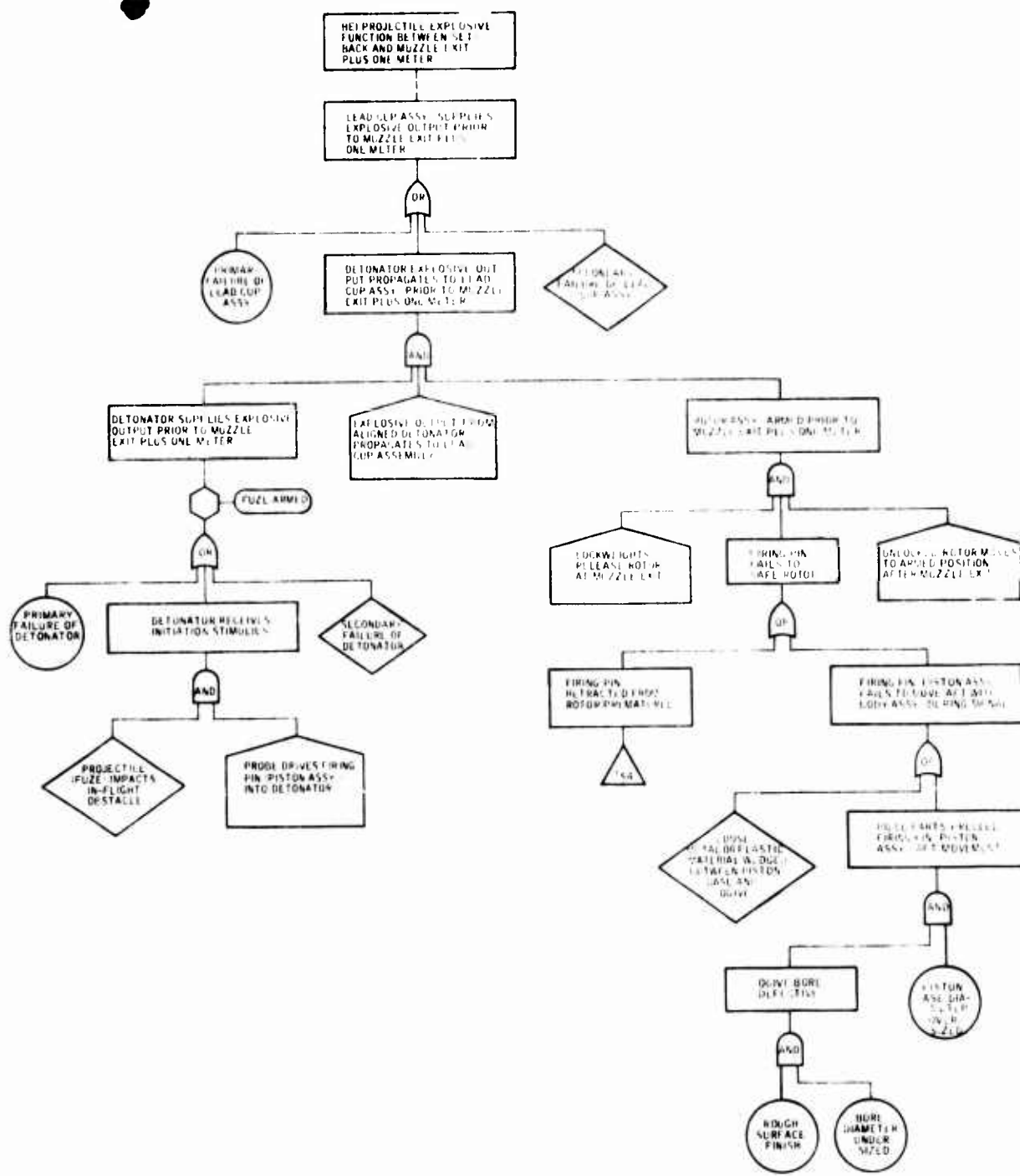

Figure A-6. Muzzle Exit plus One Meter Fault Tree

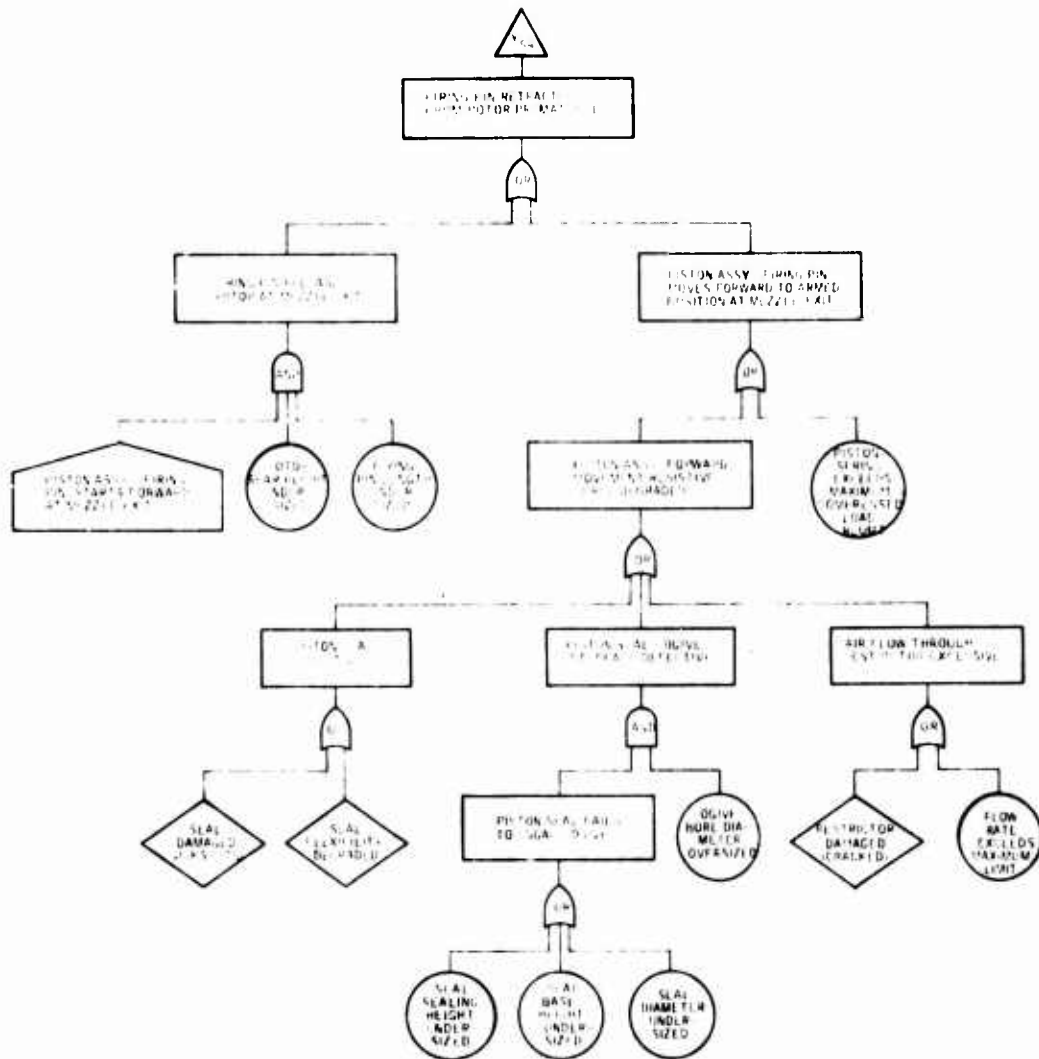

Figure A-6. Muzzle Exit plus One Meter Fault Tree (Concluded)

Based on information available at this time, the following recommendations are proposed:

- Proceed with plans to switch to PBXN-5 explosive material (or other material acceptable per MIL-STD-1316A) beyond the fuze rotor.
- Continue the hazard analysis activities in any follow-on development effort.

APPENDIX B
SELECTED CARTRIDGE, PROJECTILE, FUZE
AND FLASH X-RAY PHOTOGRAPHS

Selected 20mm HEI/XM714A3 cartridge assembly, projectile assembly, XM714A3 Mod III fuze assembly, and flash x-ray photographs are presented in Figures B-1 through B-11. Delay function distances indicated in the x-ray photographs (Figures B-7 through B-11) are for the Mod III fuze design (delay $\approx 7.5 \pm 2.5$ inches). The deliverable Mod XI fuze design with a nylon ball produced longer delays (10 ± 4 inches).

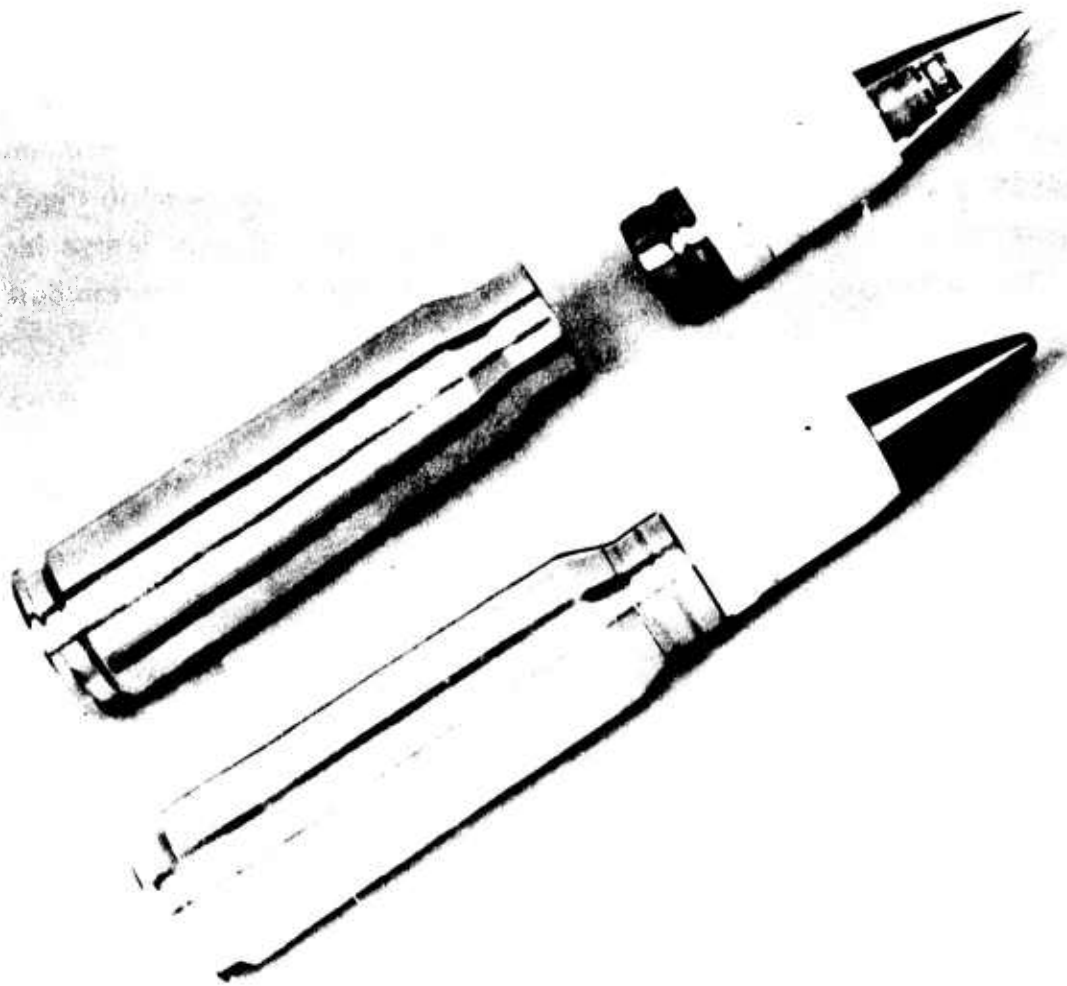

Figure B-1. Test Vehicle Cartridge Assembly

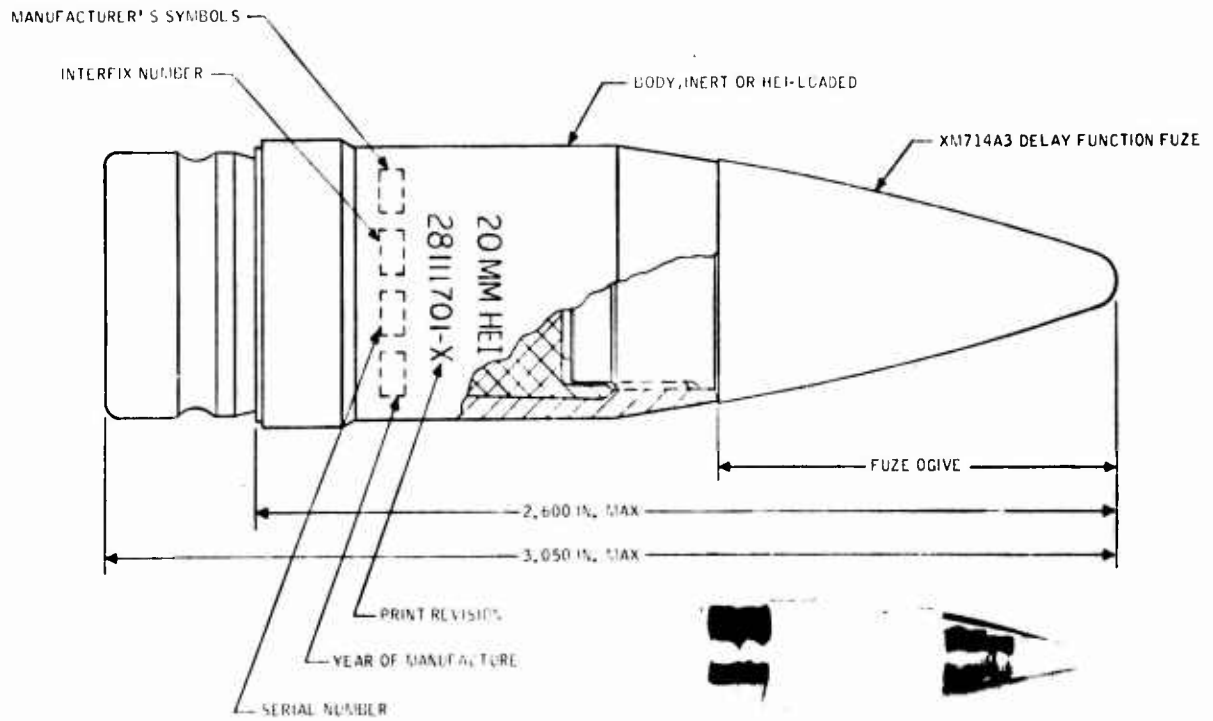

Figure B-2. Test Vehicle Projectile Assembly Layout

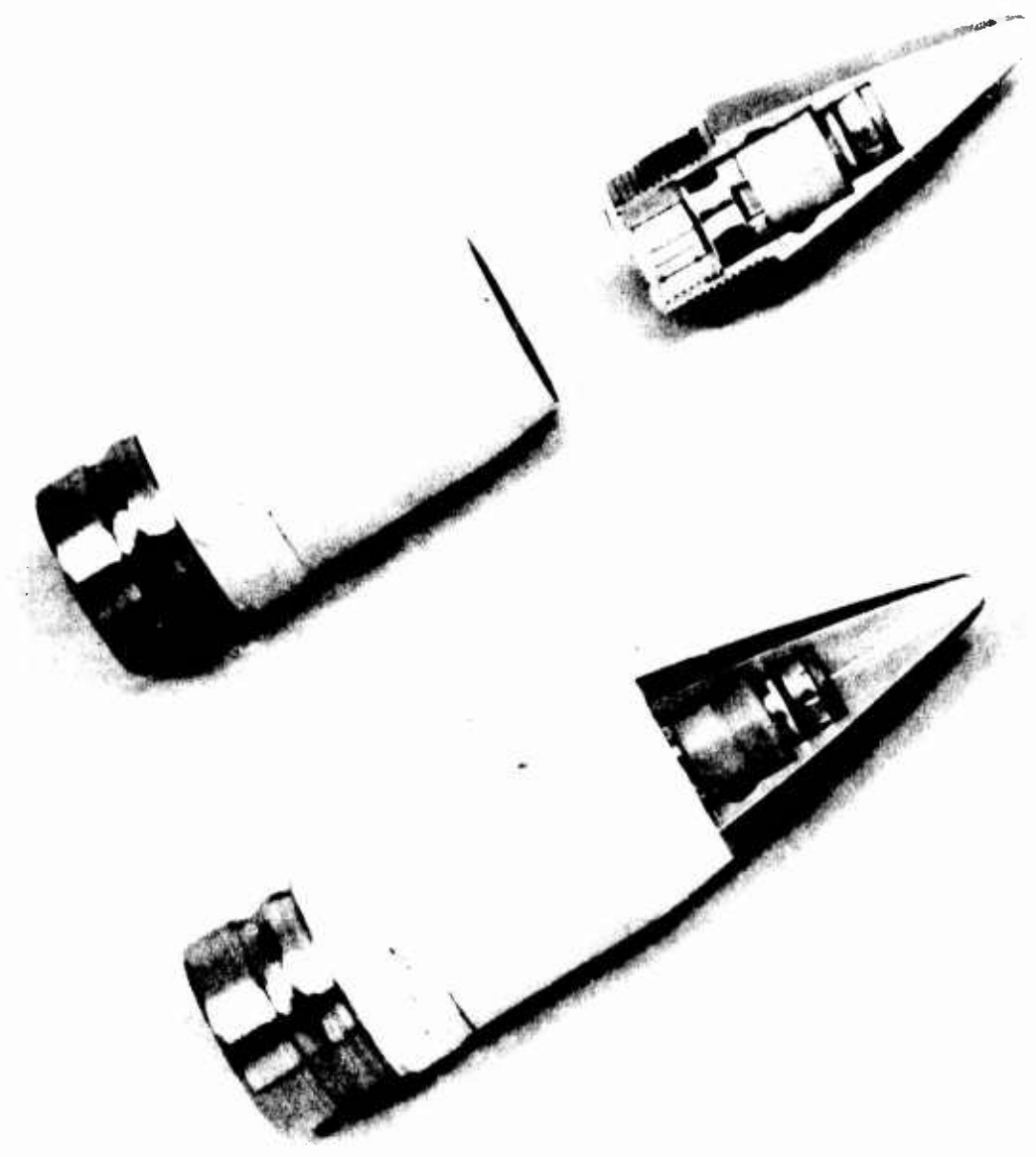
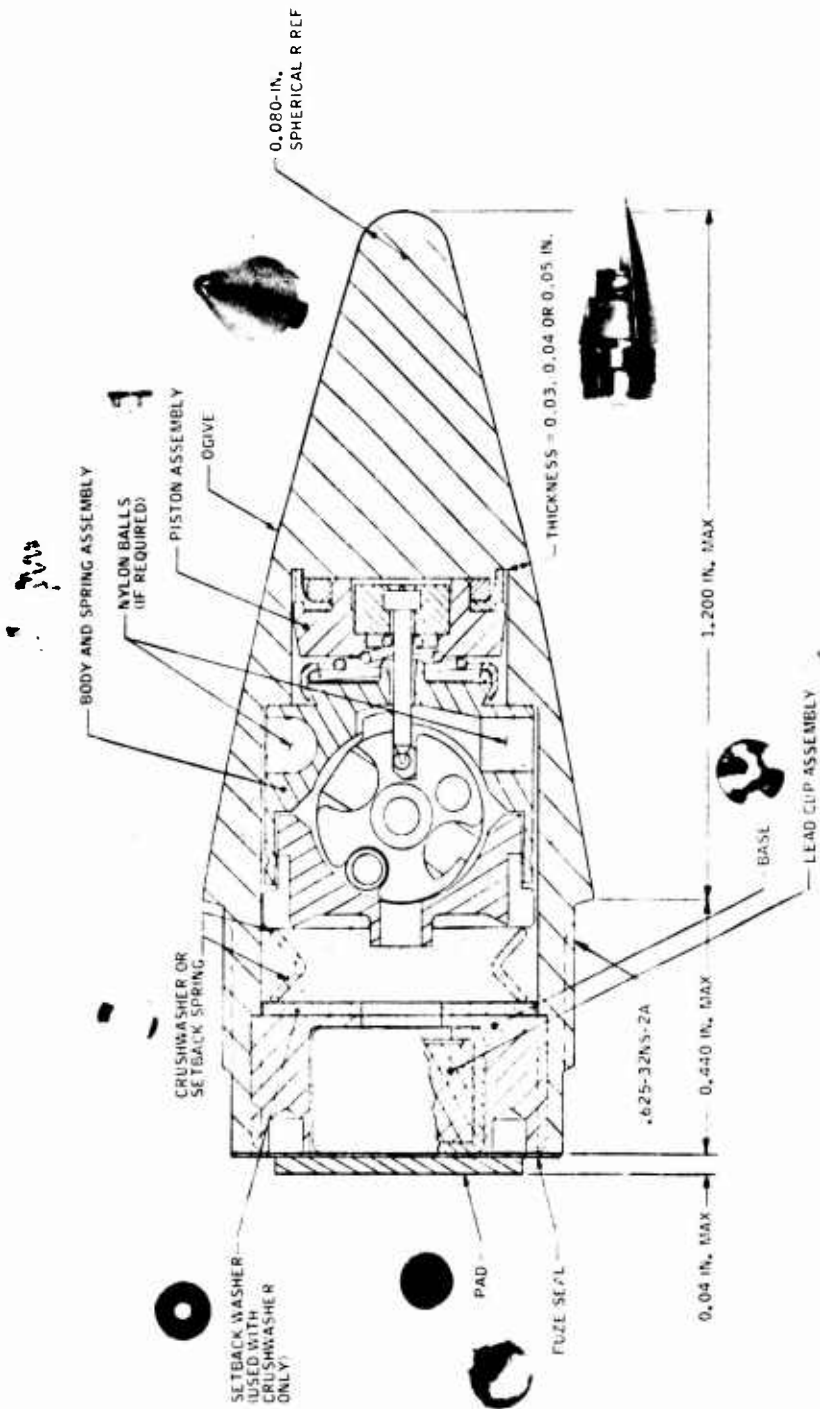

Figure B-3. Test Vehicle Projectile Assembly Cutaway View



| FUZE MOD | PISTON SPRING FORCE (lb.) | 2024 ALUM. CRUSHWASHER | NYLON BALLS | BALL RAMP ANGLE (deg) | FP-DETONATOR CLEARANCE (in.) | SLIDER | LUBRICATION |
|----------|---------------------------|------------------------|-------------|-----------------------|------------------------------|--------|-------------|
| I | 1.50 | ORIGINAL (T4) | 0 | -- | 0.05 | NO | MOLYKOTE |
| II | 1.50 | SETBACK SPRING | 2 | 45 | 0.09 | NO | MOLYKOTE |
| III | 1.50 | ORIGINAL (T4) | 0 | -- | 0.07 | NO | MOLYBUFF |
| XIV | 0.55 | SETBACK SPRING | 2 | 25 | 0.07 | NO | MOLYBUFF |

Figure B-4. XM714A3 Delay Function Fuze Layout

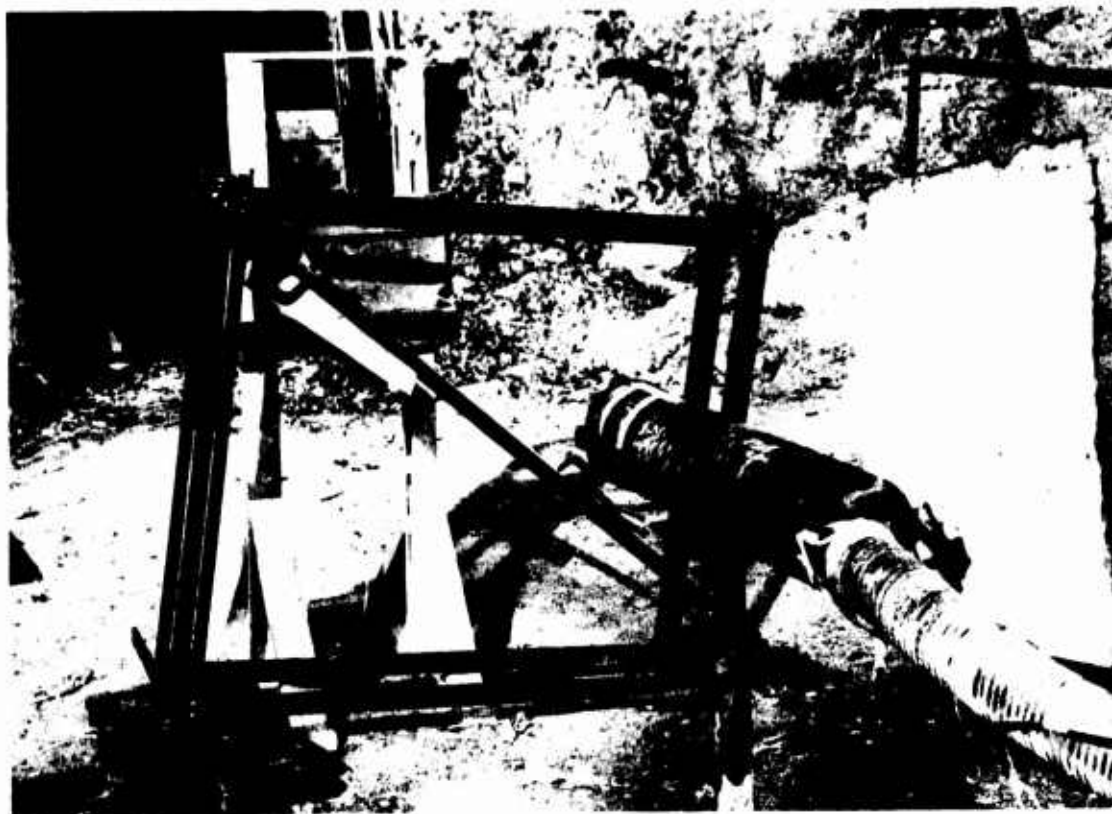

Figure B-6. Target Holder and X-Ray Setup



Figure B-7. Flash X-Ray - Mod III Fuze with 0.05-inch-Walled AISI 1144 Ogive 311 microseconds after 3600 (+) - ft/s Impact with 0.09-inch 2024-T3 Aluminum at 70-degree Obliquity (The x-ray shows the detonator is just beginning to function, indicating a delay of approximately 13 inches. This fuze was evaluated with an inert-filled, polyarylene-banded, thin-wall projectile body and was recovered intact from the softcatcher.)

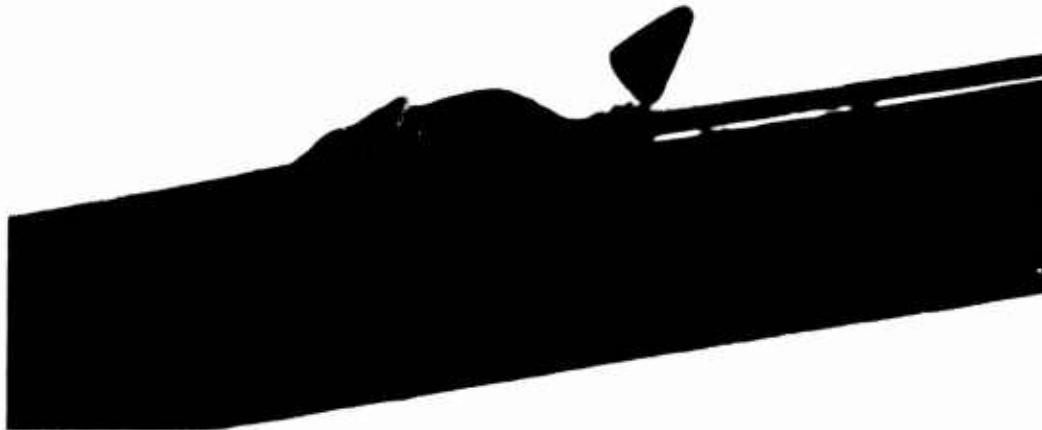

Figure B-8. Flash X-Ray - Mod III Fuze with 0.04-inch-Walled 17-4PH Ogive and HEI-Loaded Projectile Assembly 119 Microseconds (5.0-inch delay) after 3560-ft/s Impact with 0.09-inch Aluminum at 80-degree Obliquity (Note that the projectile is just beginning to detonate.)

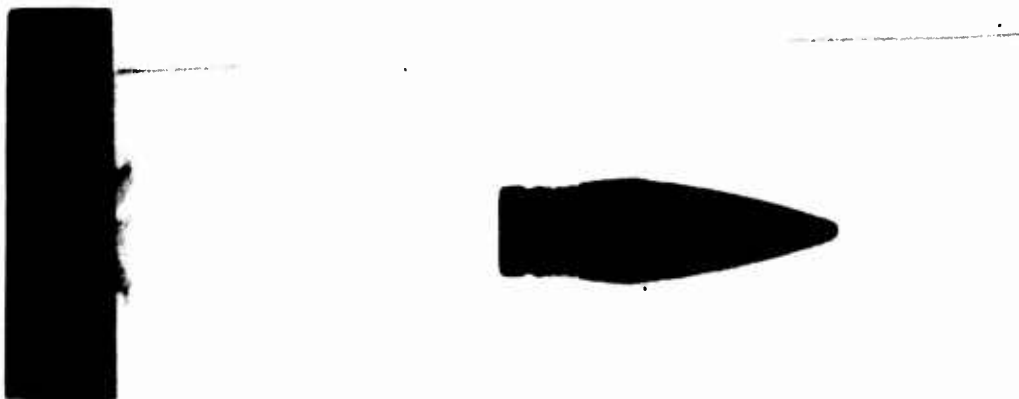

Figure B-9. Flash X-Ray - Mod III - Fuzed Projectile 6.8 Inches After 2584-ft/s Impact with 0.0625-inch Aluminum at 0-degree Obliquity (Note that the projectile has a slight bulge, indicating it is just beginning to function.)



Figure B-10. Flash X-Ray - Mod III - Fuzed Projectile 201 Microseconds After 2625-ft/s Impact with 0.0625-inch Aluminum at 0-degree Obliquity [Note that it is beginning to fragment (delay = 6.3 inches)]

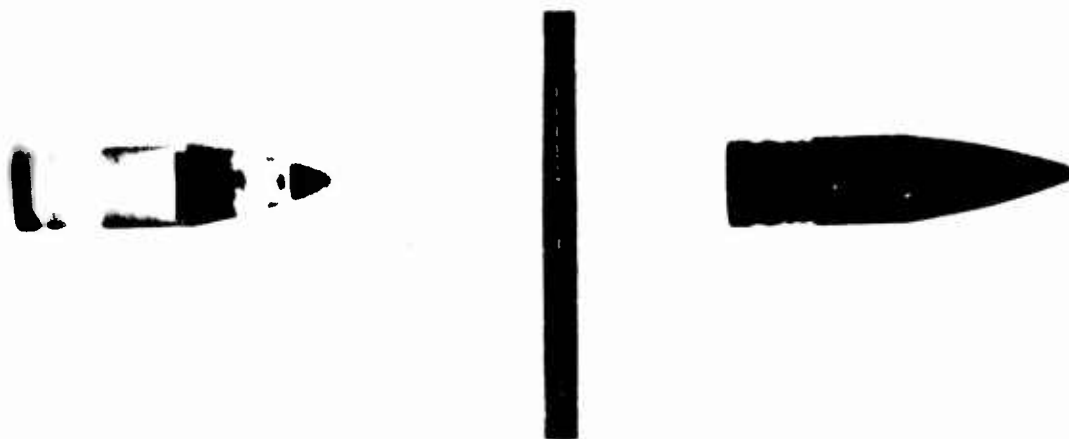

Figure B-11. Inflight Flash X-Ray of Mod-III - Fuzed Projectile Before 2611-ft/s Impact with 0.0625-inch Aluminum at 0-degree Obliquity (This unit subsequently functioned high-order with a delay of 6.3 inches)

INITIAL DISTRIBUTION

| | |
|----------------------|----|
| HQ USAF/SAMI | 1 |
| AFIS/INTA | 1 |
| ASD/ENFEA | 1 |
| Ogden ALC/MMWM | 2 |
| TAWC/TRADOCLO | 1 |
| AFATL/DL | 1 |
| AFATL/DLD | 1 |
| AFATL/DLOSL | 9 |
| ADTC/SD-20 | 10 |
| DDC | 2 |
| AUL (AUL-LSE-70-239) | 1 |

ERRATA

AFATL-TR-76-105

DEVELOPMENT OF XM714A3

DELAY FUNCTION FUZE

AIR FORCE ARMAMENT LABORATORY
ARMAMENT DEVELOPMENT AND TEST CENTER
EGLIN AIR FORCE BASE, FLORIDA

1. Replace existing pages 25-26, 29-30, 31-32, 75-76 with attached pages.
2. This errata is unclassified.

SECTION IV
FUZE EVALUATION

PLANNED VERSUS ACTUAL TESTS

The contractor's original approved test plan is shown in Table 3. It called for 230 tests. Planned quantities are compared with actual test quantities below:

| | <u>Planned</u> | <u>Actual</u> |
|-------------------------|----------------|---------------|
| Early Tests | 80 | 79 |
| Final Tests | 120 | 120 |
| Supplemental Tests | 0 | 44 |
| Pre-LAT | 0 | 20 |
| Final-LAT | 30 | 20 |
| Post-Delivery Tests | 0 | 90 |
| Subtotal | 230 | 373 |
| Miscellaneous Lab Tests | 0 | 51 |
| Total | 230 | 424 |

EARLY TESTS

Early tests included 37 structural impact gun tests and 42 all-up round delay function gun tests (37 + 42 = 79 as shown above). The 51 miscellaneous laboratory tests conducted during the program are also discussed in this section.

- (2) Both 17-4PH and C1144 ogives with wall thickness of 0.03 and 0.04 inch failed on impact with 0.09-inch 2024-T3 aluminum targets at 80-degree obliquity; however, the detonators functioned properly into the leads on most units. The 0.05-inch-walled 17-4PH and C1144 ogives withstood 0.09-inch, 80-degree impacts. The C1144 ogive with 0.05-inch wall was selected for follow-on fabrication and delivery as it provided the best performance (see units 21-25, Table 4) and because of its low cost and excellent machinability (see Table 2).
- (3) Certain changes were made to the C1144 ogive to further increase structural integrity during impact. These changes included addition of 0.015 to 0.005 R fillets in the piston and body assembly bore and increasing the minor thread diameter.
- (4) Only one arming failure was noted in 25 shots. This appeared to be caused by deformation of the glass-filled nylon upper body during setback.

A second, 12-shot, softcatch test was conducted at high and low velocity to analyze structural integrity of internal parts because of the deformation noted in (4) above. The test plan was as follows:

| <u>Qty</u> | <u>WC870 Propellant Weight (gm)</u> | <u>Velocity (ft/s)</u> | <u>Fuze Design</u> |
|------------|---|----------------------------|---|
| 3 | 40 | 3700 | Baseline Inertial, per Figure 6 (Mod I). |
| 3 | 40 | 3700 | Alternate Ball Release Stored Energy per Figure 6 (Mod II). |
| 3 | 25 | 2500 | Baseline Inertial per Figure 6 (Mod I). |
| 3 | 25 | 2500 | Alternate Ball Release Stored Energy per Figure 6 (Mod II). |

Each of the four above defined three-unit groups consisted of two fuzes with lockweights and one without lockweights. All 12 fuzes contained inert detonators and leads and were attached to HEI-filled projectiles. The units were fired into a polystyrene-bead-filled catcher placed 100 feet downrange from the gun muzzle. Projectile velocity was determined using coils placed 18 and 28 feet downrange from the muzzle. Projectile accuracy was monitored for high- and low-velocity units with results as follows:

- At 3700 ft/s: average mean radius = 1.10 mil at 100 feet
- At 2500 ft/s: average mean radius = 0.60 mil at 100 feet

These accuracy values did improve with the end item because a consistent ogive wall thickness (consistent projectile weight) was specified; i. e., wall thickness of 0.03 to 0.05 inch produced projectile weight variations of 1158 grains to 1226 grains respectively.

Fuze design, velocity at 23 feet downrange, and softcatch recovery measurements (before and after test) are given in Table 5. Conclusions were as follows:

- (1) All fuzes were fully armed at entry into catcher. This was evidenced by the firing pin imprinting the center of the inert detonator.
- (2) Crushwashers deformed properly under setback loads. Washer thickness was 0.026 inch minimum, and the outside diameter was 0.487 inch maximum. There was no difference between high- and low-velocity units.
- (3) Lower body deformation from setback loads does not prevent rotor arming or restrict body assembly movement during delay function. Imprints of the rotor and roller weight, in the out-of-line position, were evident in the lower body. Heavy imprints, 0.005- to 0.010-

THIS PROGRAM COMPUTES SELF DESTRUCT SPIN RATE AND THE CHANGE IN PROJECTILE VELOCITY REQUIRED TO TRIGGER THE XM714 TYPE OF BALL RELEASE MECHANISM AS A FUNCTION OF FUZE PARAMETERS, FIRING PIN ENERGY, DELAY FUNCTION TIME, AND PROJECTILE TRAVEL DISTANCE BETWEEN TARGET IMPACT AND DETONATION AS A FUNCTION OF FIRING PIN-DETONATOR CLEARANCE IS ALSO COMPUTED. A DETONATOR INITIATION TIME OF 50 MICROSECONDS IS ASSUMED AFTER IMPACT WITH THE FIRING PIN. ALSO, Q MUST BE EQUAL TO OR GREATER THAN DX FOR ENERGY CALCULATIONS. ANGLE1, ANGLE2, ANGLE3, RN, SPIN! 25, 0, 0, 2, 2000.

WN, WB, WR! .000017, .00573, .0
 FSD, FPD, RKS, RKP! 2.4, 55, 9.2, 3.33
 FO, FB, FR, FH! .2, .075, .074-5, .1 MI = 0.1
 YMAX, DX, E, YMIN! .21262, .02, .01, .1989
 VP, DV, DC, DC, CMAX! 3500, 16.2, .04, .01, .101

TRIGGER VELOCITY(FPS)= 7.20627389
 SELF DESTRUCT SPIN RATE(RPS)= 1292.93212890

| F.P. CLEARANCE (INCH) | F.P. ENERGY (IN-OZ) | DELAY TIME (MICROSEC) | DELAY DISTANCE (INCH) |
|-----------------------------|---------------------------|-----------------------------|-----------------------------|
| 0.04000000 | 3.21330214 | 267.96484375 | 11.21210638 |
| 0.05000000 | 2.96280718 | 329.97125244 | 13.79425049 |
| 0.05999999 | 2.6922430 | 394.7736475 | 16.50328445 |
| 0.06999999 | 2.40214391 | 463.05535889 | 19.35772994 |
| 0.08000000 | 2.09199524 | 535.7656914 | 22.39736938 |
| 0.09000000 | 1.76294811 | 614.30395508 | 25.68061066 |
| 0.10000001 | 1.41201425 | 700.89172363 | 29.30036163 |

MORE RUNS! 1.=YES, 2.=NO! 1.

(a)
 No Upper
 Body
 Deformation

ANGLE1, ANGLE2, ANGLE3, RN, SPIN! 25, 0, 0, 2, 2000.
 WN, WB, WR! .000017, .00573, .0
 FSD, FPD, RKS, RKP! 2.4, 55, 9.1, 3.33
 FO, FB, FR, FH! .1, .075, .075, .172 MI = 0.172
 YMAX, DX, E, YMIN! .21262, .02, .01, .1989
 VP, DV, C, DC, CMAX! 3500, 16.3, .04, .01, .101

TRIGGER VELOCITY(FPS)= 9.28593626
 SELF DESTRUCT SPIN RATE(RPS)= 1068.15126718

| F.P. CLEARANCE (INCH) | F.P. ENERGY (IN-OZ) | DELAY TIME (MICROSEC) | DELAY DISTANCE (INCH) |
|-----------------------------|---------------------------|-----------------------------|-----------------------------|
| 0.04000000 | 2.03871346 | 287.33593750 | 12.01190567 |
| 0.05000000 | 1.39291389 | 369.53570557 | 15.44621930 |
| 0.05999999 | 0.92922286 | 469.15466309 | 19.61272812 |
| 0.06999999 | 0.3445170 | 609.47363281 | 25.47858729 |
| 0.08000000 | 0.00000000 | | |
| 0.09000000 | 0.00000000 | | |
| 0.10000001 | 0.00000000 | | |

MORE RUNS? 1.=YES, 2.=NO! 2.

(b)
 With Upper
 Body
 Deformation

STOP. DONE

Figure 18. Calculated Fuze Mod IV Sensitivity (3500-ft/s, 0-degree obliquity impact against 0.063-inch 2024-T3 aluminum)

500-Meter Function Demonstration

The 20-shot 500-meter function demonstration was conducted on 4 August. Eglin AFB sent 20 of the deliverable projectiles back to the contractor for this test. The test involved firing the projectiles at maximum velocity against 0.125-inch 2024-T3 aluminum targets placed 500 meters downrange at 0-degree obliquity. Instrumentation included velocity coils and LOCAM color movies behind the target as shown in Figure 19.

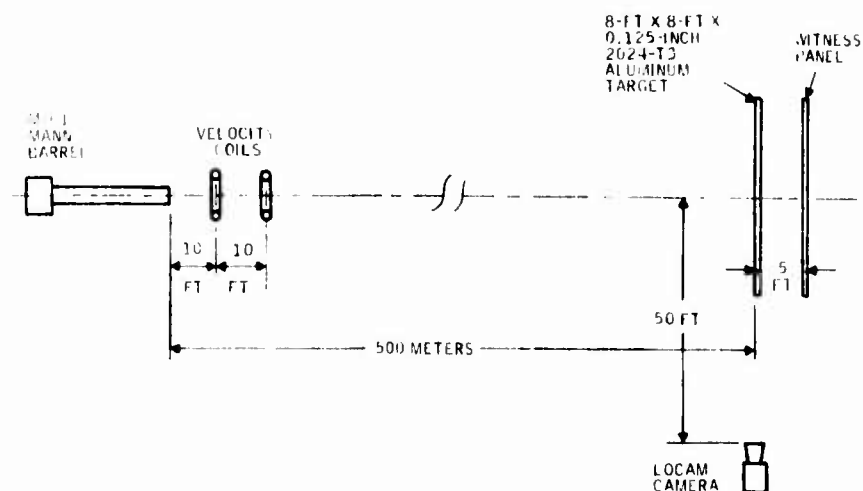

Figure 19. 500-meter Function Demonstration Test Setup

Initial conditions were as follows:

- Fuze -- XM714A3 Mod XI as defined in Figure 1
- Projectile -- 1226-grain polyarylene-banded thin-wall projectile containing 193 grains of LCA 1 HEI mix (Figure 2)
- Cartridge -- M103 case with 610 grains .5 gram of Olin WC870 ball propellant (Figure 3)