

SECURITY

MARKING

The classified or limited status of this report applies to each page, unless otherwise marked.

Separate page printouts MUST be marked accordingly.

THIS DOCUMENT CONTAINS INFORMATION AFFECTING THE NATIONAL DEFENSE OF THE UNITED STATES WITHIN THE MEANING OF THE ESPIONAGE LAWS, TITLE 18, U.S.C., SECTIONS 793 AND 794. THE TRANSMISSION OR THE REVELATION OF ITS CONTENTS IN ANY MANNER TO AN UNAUTHORIZED PERSON IS PROHIBITED BY LAW.

NOTICE: When government or other drawings, specifications or other data are used for any purpose other than in connection with a definitely related government procurement operation, the U.S. Government thereby incurs no responsibility, nor any obligation whatsoever; and the fact that the Government may have formulated, furnished, or in any way supplied the said drawings, specifications, or other data is not to be regarded by implication or otherwise as in any manner licensing the holder or any other person or corporation, or conveying any rights or permission to manufacture, use or sell any patented invention that may in any way be related thereto.

CONFIDENTIAL

AFATL-TR-68-87

AD 501759

AD 501759

BLU-30/B
(NONHAZARDOUS)
BOMBLET (U)

K. Spurbeck
HONEYWELL INC.

TECHNICAL REPORT AFATL-TR-68-87

JULY 1968

This material contains information affecting the national defense of the United States within the meaning of the Espionage Laws (Title 18, U.S.C., sections 793 and 794), the transmission or revelation of which in any manner to an unauthorized person is prohibited by law.

MAY 2 1969

In addition to security requirements which must be met, this document is subject to special export controls and each transmittal to foreign governments or foreign nationals may be made only with prior approval of the Air Force Armament Laboratory (ATCC), Eglin AFB, Florida 32542.

AIR FORCE ARMAMENT LABORATORY

AIR FORCE SYSTEMS COMMAND • UNITED STATES AIR FORCE

EGLIN AIR FORCE BASE, FLORIDA

GROUP-4
DOWNGRADED AT 3 YEAR INTERVALS;
DECLASSIFIED AFTER 12 YEARS.

CONFIDENTIAL

CONFIDENTIAL

BLU-30/B (NONHAZARDOUS) BOMBLET (U)

K. Spurbeck

This material contains information affecting the national defense of the United States within the meaning of the Espionage Laws (Title 18, U.S.C., sections 793 and 794), the transmission or revelation of which in any manner to an unauthorized person is prohibited by law.

In addition to security requirements which must be met, this document is subject to special export controls and each transmittal to foreign governments or foreign nationals may be made only with prior approval of the Air Force Armament Laboratory (ATCC), Eglin AFB, Florida 32542.

GROUP-4
DOWNGRADED AT 3 YEAR INTERVALS;
DECLASSIFIED AFTER 12 YEARS.

CONFIDENTIAL

CONFIDENTIAL

FOREWORD

(U) This is the Final Technical Report covering the advanced development of the nonhazardous BLU-30/B bomblet. Work on this program was conducted from June 1966 to May 1968 by Honeywell Inc., Ordnance Division, Hopkins, Minnesota, under U.S. Air Force Contract AF 08(635)-5863. The program was monitored by the Air Force Armament Laboratory (ATCC), Eglin Air Force Base, Florida.

(U) Appreciation for the conduct of this program is expressed to the following personnel:

Honeywell Inc.

Raymond H. Burg - Project Supervisor
King Spurbeck - Project Engineer
John V. Soucek - Project Administrator
John P. Sumner - Evaluation Engineer
Richard F. Fogal - Evaluation Engineer

IIT Research Institute

Donald K. Werle - Research Chemist
T. M. Rymarz - Assistant Research Chemist

AFATL (ATCC) Eglin Air Force Base

Captain R. L. Finocchio - Project Officer

(U) This report is classified CONFIDENTIAL because of information contained herein regarding the military application and predicted effectiveness of this munition system.

(U) This report contains no classified information extracted from other classified documents.

(U) Information in this report is embargoed under the Department of State International Traffic In Arms Regulations. This report may be released to foreign governments by departments or agencies of the U.S. Government subject to approval of the Air Force Armament Laboratory (ATCC), Eglin AFB, Florida 32542, or higher authority within the Department of the Air Force. Private individuals or firms require a Department of State export license.

(U) Publication of this report does not constitute Air Force approval of the report's findings or conclusions. It is published only for the exchange and stimulation of ideas.

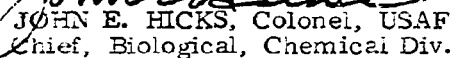
JOHN E. HICKS, Colonel, USAF
Chief, Biological, Chemical Div.

-ii-

CONFIDENTIAL

(This page is Unclassified)

UNCLASSIFIED ABSTRACT

(U) This report discusses the design and development of the BLU-30/B23 bomblet from its inception in June 1966 to prototype delivery to the Air Force for flight tests in May 1968. The BLU-30/B23 is a submunition cluster bomblet designed for delivery from the SUU-13/A dispenser. It provides, upon ground impact, thermal dissemination of agents CS or BZ. Theoretical area coverage and effectiveness of this bomblet for use in various counter-insurgency situations are also presented. Submunition dissemination tests conducted at Illinois Institute of Technology Research Institute (IITRI) during this program demonstrated efficiencies as high as 76 percent for CS and 40 percent for BZ. Problems encountered during Air Force testing indicate additional development of the submunition is required before a useable system would result. The primary problems encountered during the program were the determination of the most reliable ignition method for the CS and BZ pyrotechnic payloads, the compatibility of the Hooker 283 BZ pyrotechnic loading procedures with the submunition case material and the relatively low dissemination efficiencies with BZ. These problems and their resolutions and/or recommendations for further study are detailed in this report.

(U) In addition to security requirements which must be met, this document is subject to special export controls and each transmittal to foreign governments or foreign nations may be made only with prior approval of the Air Force Armament Laboratory (ATCC), Eglin AFB, Florida 32542.

TABLE OF CONTENTS

Section		Page
I	INTRODUCTION	1
	A. Background	1
II	SUMMARY	6
III	REQUIREMENTS	11
IV	FINAL DESIGN	13
	A. Design Description	13
	1. Bomblet	13
	2. Sub-bomblet	18
	B. Operation	22
V	TECHNICAL DISCUSSION	24
	A. Selection of Design	24
	1. Literature Search	24
	2. System Effectiveness Analyses	27
	3. Fuzing	61
	4. Preliminary Hardware Evaluation	65
	B. Preprototype, MIL-STD, and Flight Test Evaluation	79
	1. Sub-bomblet Refinement Testing	79
	2. MIL-STD and Preflight Demonstration Tests	92
	3. Development Flight Tests	97
VI	CONCLUSIONS AND RECOMMENDATIONS	101
	A. BLU-30/B Cluster Bomblet Concept Applications	101
	B. Sub-bomblet Improvement with BZ	102

TABLE OF CONTENTS (Continued)

Section		Page
APPENDIX I	PARACHUTE STUDY	105
APPENDIX II	SUMMARY OF LITERATURE SEARCH FOR IMPROVED BZ AND CS PYROTECHNIC FORMULATIONS	112
APPENDIX III	BOMBLET TEST AND PROTOTYPE PRODUCTION PROGRAM	115

LIST OF FIGURES

Figure	Title	Page
1	Nonhazardous Bomblet Cluster	2
2	Thermal Sub-bomblet Design	4
3	Nonhazardous Bomblet Cluster	7
4	Assembled Sub-bomblet with Dummy FMU-65 Fuze	9
5	Nonhazardous Bomblet Design	14
6	BLU-30/B Bomblet Display Model	15
7	Assembly Diagram, BLU-30/B Bomblet	16
8	Modified BLU-4 Timer	17
9	Sub-bomblet Configuration	19
10	FMU-65/B Fuze	20
11	Bomblet Function Sequence	23
12	Sub-bomblet Candidate Designs	29
13	Theoretical Cluster Patterns (Bomblet Delivered from 70-foot altitude)	31
14	Theoretical Cluster Patterns (Bomblet Delivered from 70-foot altitude)	32
15	Theoretical Cluster Patterns (Concept 1 Sub-bomblet Delivered from 2500-foot Altitude)	33
16	Theoretical Impact Pattern, Concept 1	35

LIST OF FIGURES (Continued)

Figure	Title	Page
17	Test Impact Pattern, Concept 1	36
18	Thirty Percent Contour Overlay on Theoretical Pattern	37
19	Area Coverage per Bomblet (CS Agent)	39
20	Area Coverage per Bomblet (BZ Agent)	39
21	Area Coverage at 30% Casualties and Cost Comparison for Agent BZ	41
22	Area Coverage at 30% Casualties and Cost Comparison, for Agent BZ, 50-foot Delivery	42
23	Area Coverage at 30% Casualties and Cost Comparison, Agent CS, 700-foot Delivery Altitude at 780 Knots	43
24	Area Coverage at 30% Casualties and Cost Comparison, Agent CS, 50-foot Delivery Altitude at 300 Knots	44
25	Rate of Area Coverage Development Agent CS	45
26	Rate of Area Coverage Development, Agent BZ	47
27	Bomblet Cost Comparison	48
28	Cost Effectiveness Comparison at 30% Casualties, Agent BZ (700-foot Delivery Altitude at 780 Knots)	49
29	Cost Effectiveness Comparison at 30% Casualties, Agent BZ (40-foot Delivery Altitude at 300 Knots)	50
30	Cost Effectiveness Comparison at 30% Casualties, Agent CS (700-foot Delivery Altitude at 780 Knots)	51
31	Cost Effectiveness Comparison at 30% Casualties, Agent CS (50-foot Delivery Altitude at 300 Knots)	52
32	BZ Bomblet Expenditure Requirements - Neutral Atmosphere, 5-mph Wind, $IC_{t50} = 112\text{mg-min/m}^3$	55
33	CS Bomblet Expenditure Requirements - Neutral Atmosphere, 5-mph Wind, $IC_{t50} = 5\text{mg-min/m}^3$	56

LIST OF FIGURES (Concluded)

Figure	Title	Page
34	Ninety-five Percent Sub-bomblet Impact Pattern Size, 50-foot Altitude	58
35	Ninety-five Percent Sub-bomblet Impact Pattern Size, 300-foot Altitude	59
36	Disassembled Cluster (No Sub-bomblets)	63
37	Assembled Cluster (No Sub-bomblets)	64
33	Explosive Bolt Structure Failure	69
39	Revised Explosive Bolt	69
40	Test Bomblet after 40-foot Drop	71
41	Sub-bomblet Configuration	75
42	Bottom Plate	76
43	Bottom Plate and Explosive Bolt Crimp Test Hardware	77
44	Malfunctioned Sub-bomblet	79
45	Redesigned Sub-bomblet Static Test Fixture	80
46	Typical Sub-bomblet Function	82
47	Sub-bomblet Loading Tools	86
48	Air Gun, 4. 6-inch High Pressure	93
49	BLU-26 Bomblet after Static Ejection Test: (Top) Bomblet Cluster and Sub-bomblets; (Bottom) Cluster Hardware Without Sub-bomblets	97

LIST OF TABLES

Table	Title	Page
I	SITUATION SUMMARY	54
II	OPTIMUM DELIVERY CONDITIONS FOR THE NONHAZARDOUS BOMBLET (30% CASUALTIES OR GREATER FOR BOMBLET)	62
III	SUMMARY OF THEORETICAL STRUCTURAL LOADS AND DESIGN GOALS	67
IV	STRUCTURAL STRENGTH TESTS	68
V	CANDIDATE SUB-BOMBLET MATERIALS, DESIGN CHARACTERISTICS	72
VI	RATING OF CANDIDATE SUB-BOMBLET MATERIAL BY ATTRIBUTE	73
VII	SUB-BOMBLET DISSEMINATION TEST SUMMARY	84
VIII	AEROSOL RECOVERY DATA FROM THE HOOKER BZ-LOADED SUB-BOMBLETS	88
IX	MIL-STD-810A TEST SUMMARY, BLU-30/B BOMBLET	92
X	AIR FORCE FLIGHT TEST SUMMARY	98
XI	HOOKER 283 BZ FORMULATION	107

PRECEDING PAGE BLANK, NOT FILMED

SECTION I
INTRODUCTION

A. BACKGROUND

(U) Prior to the conduct of this program the technical and functional feasibility of a nonhazardous cluster bomblet of the design illustrated in figure 1 had been established. The design consisted of a cluster of 32 thermal generating sub-bomblets, a timing and pyrotechnic delay system and a parachute decelerator.

(U) This bomblet, designed for use in the SUU-13/A dispenser, had the following characteristics:

Height	10.5 in.
Diameter	4.6 in.
Weight	7.5 lb
Decelerator	18-in. cruciform chute
Fuzing	Modified BLU-4, which provided bomb airburst after a 0.45-sec. delay
Safety	Abort safe. Parachute must be deployed above 300 kts delivery speed to activate bomb fuze.
Payload	32 thermal dissemination type sub-bomblets. Total agent payload weight was 2.0 lb.

The bomblet was designed to function as follows: Between 0.1 and 0.2 seconds after a proper release from a SUU-13/A Dispenser, the parachute would deploy. At 0.45 second from release, a modified BLU-4 timer initiated a Pyrocore element contained within the center tube of the cluster. The Pyrocore flame front, as it moved down the center tube, acted as an ignitor for a heat-initiated delay primer in each of the 32 sub-bomblets. When the flame front reached the bottom of the center tube, it initiated an explosive

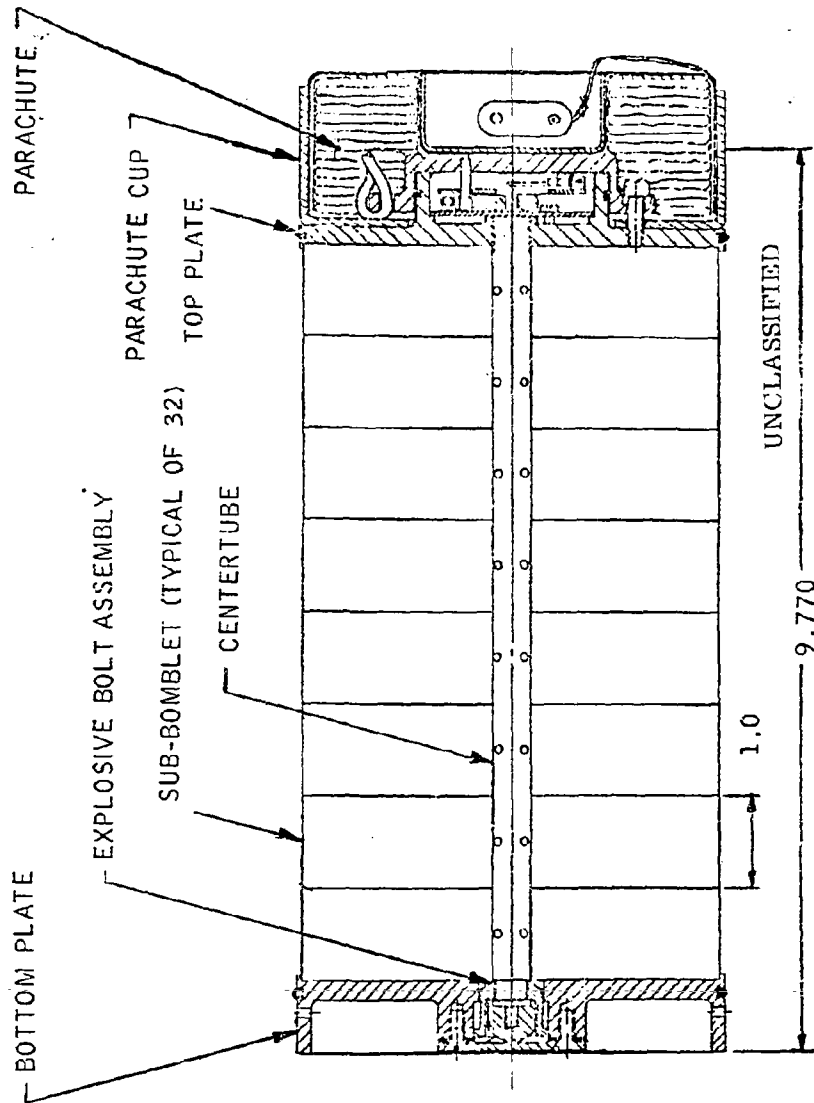

Figure 1. Nonhazardous Bomblet Cluster

bolt, the action of which telescopes the top and bottom plates of the bomblet, enabling the sub-bomblets to be released. Seven seconds after the delay primer of each sub-bomblet is initiated, the flash output of the primer would initiate the agent pyrotechnic payload, which, in turn, thermally generated an agent cloud for 10 to 20 seconds. A brief physical description of this conceptual bomblet is given in the following paragraphs.

(U) The parachute used was a cruciform type, 18-inches in diameter. It was contained in the top end of the bomblet (the end nearest the top of the dispenser tube) by a plastic cup that extended almost to the top of the dispenser tube. To protect the parachute from the hot ejection cartridge output, the top of the parachute had a fabric covering that was attached to a metal shield that surrounds the high pressure chamber when the bomblet is in place in the dispenser tube. This fabric covering was a laminate of two materials. The outer one, which received the direct output of the cartridge, was a 0.010-inch thick, silicone-coated fiberglass. Although the cartridge flame could not penetrate or melt this material, it was felt the heat could possibly be transferred through the material and melt the nylon parachute material. This heat transfer was prevented by the second layer of material, which was 0.040-inch thick Fiber Frax, an efficient thermal insulating material similar to asbestos, but with a higher temperature resistance.

(U) It was considered necessary to provide a means for pulling the parachute out of the protective container (the plastic cup and the fiber covering) as the bomblet was ejected from the tube. This was accomplished by attaching a pullwire from the chute canopy center to the dispenser. This pullwire was 30 inches long and was attached to the high pressure chamber by a 30- to 50-pound breaklink. Thus, upon ejection, the chute deployed, and the pullwire separated from the dispenser and continued to the ground with the cluster.

(U) The sub-bomblet, which is illustrated in figure 2, was designed to thermally disseminate either BZ or CS agents. The characteristics of this original sub-bomblet were as follows:

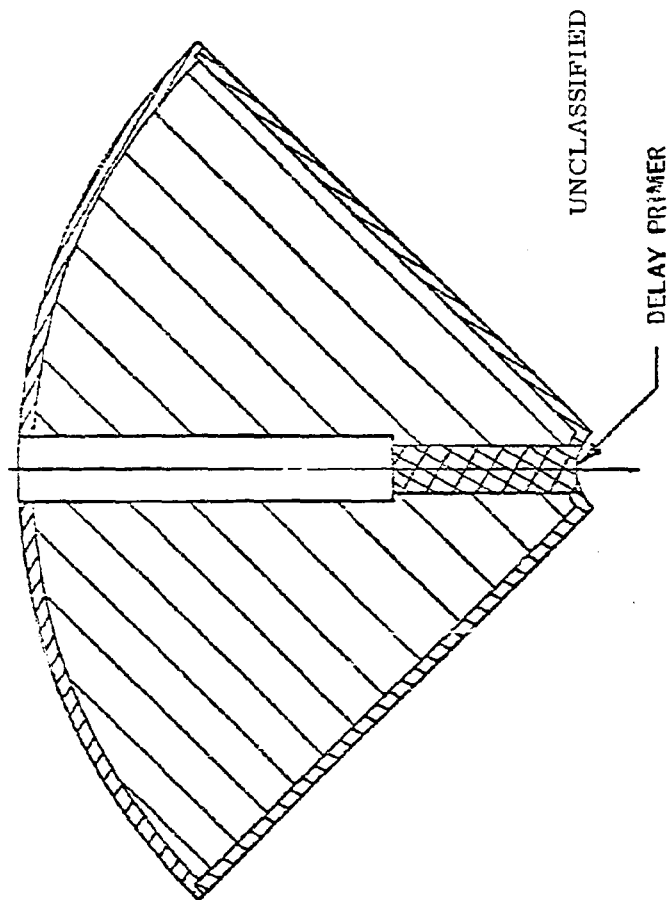

Figure 2. Thermal Sub-bomblet Design

CONFIDENTIAL

Height	1.0 in.
Configuration	Quarter segment of a 4.6-in. circle
Material	Cyclac - an ABS plastic
Volume	55 cc (usable)
Weight	0.15 to 0.16 lb.
Fuzing	Delay primer
Agent Payload	0.062 lb. each

(U) The delay primers used in the sub-bomblet were designed to satisfy three basic requirements: that the primer be heat initiated, that it have a 7.0-second delay, and that it provide a flash output sufficient to ignite the pyrotechnic agent payload.

(U) The nonhazardous aspect of the bomblet was provided by the parachute. After the sub-bomblets were released, the cluster weight was approximately 1.5 pounds. The 1.5-pound cluster was rapidly decelerated by the parachute so that cluster impact was in the 10 to 15-foot-pound energy range, even for a 50-foot, Mach 1.2 release. Moreover, the sub-bomblets were not released until the chute had slowed the bomblet to a velocity that prevents the impact energy of the sub-bomblets from ever exceeding 35 foot-pounds of impact energy.

(U) The sub-bomblets were of such a size and weight that at terminal velocity the impact energy was in the 30- to 35-foot-pound range. These impact energies were below those considered to be potentially injurious and, therefore, were also non-hazardous.

(U) The advanced development and refinement of this bomblet concept as our effective weapons system is delineated in this report.

CONFIDENTIAL

SECTION II

SUMMARY

(C) The basic requirements for the advanced development of the nonhazardous bomblet concept are that it be compatible with the SUU-13/A dispenser and that it effectively and efficiently disseminate the nonlethal chemical agents CS and BZ over large geographical areas without inflicting serious injury to target personnel. The ultimate objective is to create a submunition and cluster design that shall be compatible with incapacitating chemical agents bearing a variety of physical characteristics and utilizing a variety of dissemination techniques.

(U) The bomblet developed has been designated as the BLU-30/B23.

(U) The results of the development tests conducted during this program established that the nonhazardous BLU-30/B bomblet is compatible with and can be delivered by tactical fighter aircraft from a SUU-13/A dispenser. It was shown that the sub-bomblet cluster would be effectively dispersed in the target area, and that any component of the bomblet is theoretically incapable of seriously injuring personnel in the target area. The design is readily adaptable to production methods.

(U) The design that was developed (see figure 3) is an improved version of the bomblet described in Section I. Improvements to the bomblet included a simplified parachute package, incorporation of reliable impact-sensitive fuze and quickmatch ignitor in the sub-bomblets, and the overall cost reduction of the primary bomblet components. The most significant improvement was the replacement of the pyrotechnic delay fuze in the sub-bomblet with a modified version of the FMU-65/B impact initiated, omnidirectionally sensitive fuze. In addition to simplifying the design mechanization, the use of the FMU-65/B fuze eliminated the need for a flotation device to ensure function when the sub-bomblets are used on

CONFIDENTIAL

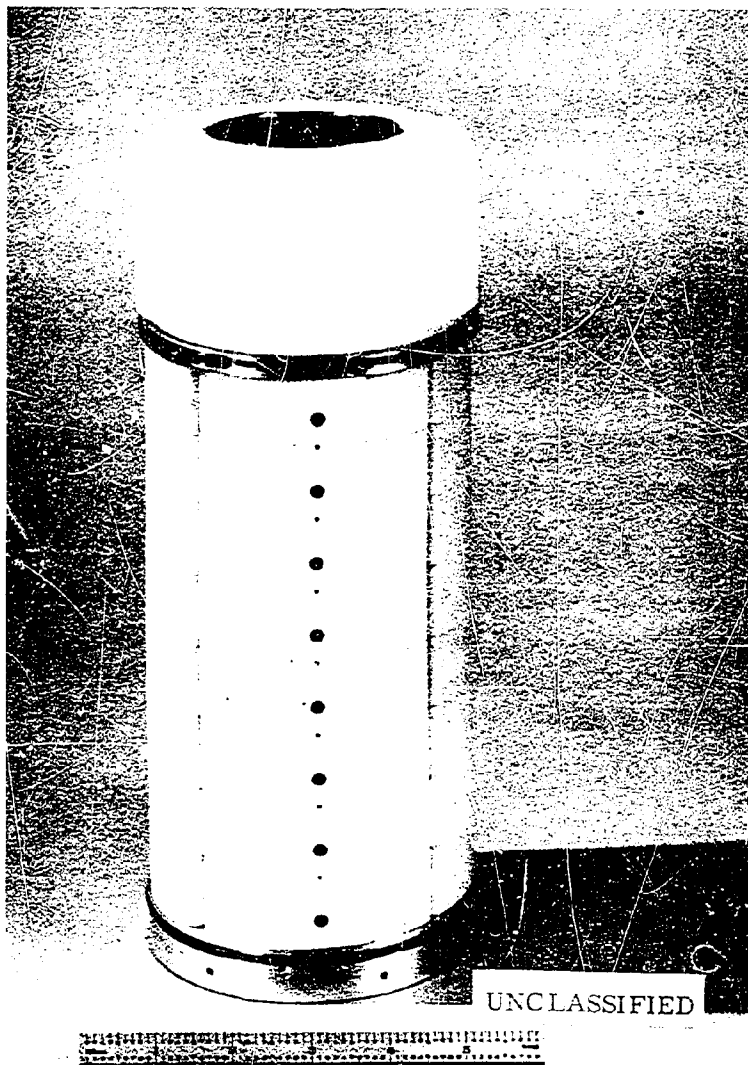

Figure 3. Nonhazardous Bomblet Cluster

-7-

CONFIDENTIAL
(This page is Unclassified)

CONFIDENTIAL

water targets. Also, the restriction of a 700-foot maximum release altitude was eliminated, and the possibility of degrading the system effectiveness due to airburst events was precluded by the impact fuze initiation mode.

(U) The sub-bomblet developed is shown in figure 4. The area coverage and cost/effectiveness studies showed the 1-inch thick 90° wedge-shaped configuration to be the most desirable of five configurations studied. The body shape is such that the sub-bomblets positively interlock with each other when in the cluster. Positive safing is provided in each FMU-65/B fuze by a spring loaded S&A pin which rides against the adjacent sub-bomblet in the cluster. When the cluster is released, each sub-bomblet fuze arms individually. The sub-bomblet is designed so the cluster can only be released when the parachute decelerator is properly deployed in a release environment of at least 140 knots.

(U) The bomblet was shown to withstand satisfactorily the specified MIL-STD-810A environments. Tests during the program demonstrated satisfaction of the following MIL-STD-810A requirements:

High Temperature	- Method 501
Low Temperature	- Method 502
Temperature Altitude	- Method 504
Humidity	- Method 507
Vibration	- Method 514
Shock	- Method 516

(C) Some problems, however, were encountered in the construction of the sub-bomblet. The sub-bomblet bodies were molded of X-27 Cycloac. Although compatible with standard CS pyrotechnical formulations, this material was found to be incompatible with the acetone in the Hooker 283

CONFIDENTIAL



Figure 4. Assembled Sub-bomblet with Dummy FMU-65 Fuze

CONFIDENTIAL

BZ pyrotechnic formulation. The ignitor and venting system, both of which worked successfully with CS, were deficient when used with BZ. While the dissemination tests showed recovery rates for CS as high as 76 percent, the highest recovery rate recorded for BZ was 40 percent. The answer to the material incompatibility problem lies in the use of glass-fluid nylon (Nylafil) or aluminum for the sub-bomblet body. The recommendations for improved BZ dissemination efficiency include nonresidue ignitors, improved venting and improved loading quality.

CONFIDENTIAL

SECTION III REQUIREMENTS

(U) The nonhazardous bomblet developed was designed to meet the following requirements:

Ejection

(C) The bomblet shall be capable of ejection at all ranges of speeds and altitudes within the capabilities of the SUU-13/A, with the exception that the bomblet will be required to abort function when ejected at less than 140 knots.

Safety

(U) The bomblet shall be failsafe on inadvertent ejection; that is, the bomblet shall be so designed that, in all modes of handling and usage it cannot function or open before it is intentionally armed.

Nonhazardous Characteristic

(U) The effect of the bomblet on the target area shall be that of the agent; that is, the hardware or dissemination technique shall not inflict excessive injury to target personnel.

Effectiveness

(C) The bomblet shall provide target dosage effectiveness to produce a minimum of 30 percent casualties averaged over large geographical areas within two minutes following dissemination of agent.

Sub-bomblet Size

(C) The wedge munition size shall be determined by considering its effect on maximizing area coverage and minimizing hazard-to-target personnel.

CONFIDENTIAL

Agent and Dissemination Method

(U) The wedge munitions shall be designed for thermal dissemination of BZ and CS.

Environmental

(U) The bomblet, installed in a SUU-13/A tube, shall withstand tests as prescribed in MIL-STD-810A to include high temperatures, low temperatures, temperature altitude, humidity, vibration, and shock.

CONFIDENTIAL

SECTION IV FINAL DESIGN

(U) This section summarizes the characteristics of the final engineering design for the nonhazardous bomblet.

A. DESIGN DESCRIPTION

1. Bomblet

(C) The bomblet, as shown in figures 5, 6 and 7, is a parachute-decelerated cluster of 32 pie-shaped sub-bomblets which thermally generate BZ or CS upon impact with the target area. The bomblet has the following characteristics:

Height	10.5 in.
Diameter	4.6 in.
Weight	8.0 lbs.
Decelerator	18-in. cruciform parachute
Cluster Fuze	Modified BLU-4, providing sub-bomblet dispersion 0.45 second after bomblet ejection
Sub-bomblet	Modified FMU-65/B Fuze initiates a thermal dissemination of agent pyrotechnic mix immediately upon target impact.
Safety	Abort safe when ejected at delivery velocities less than 140 knots
Payload	32 sub-bomblets, each containing 40 grams of agent pyrotechnic mix.

A modified BLU-4 fuze (see figure 8) is used to initiate a pyrocore column which, in turn, initiates an explosive bolt to release the sub-bomblets.

CONFIDENTIAL

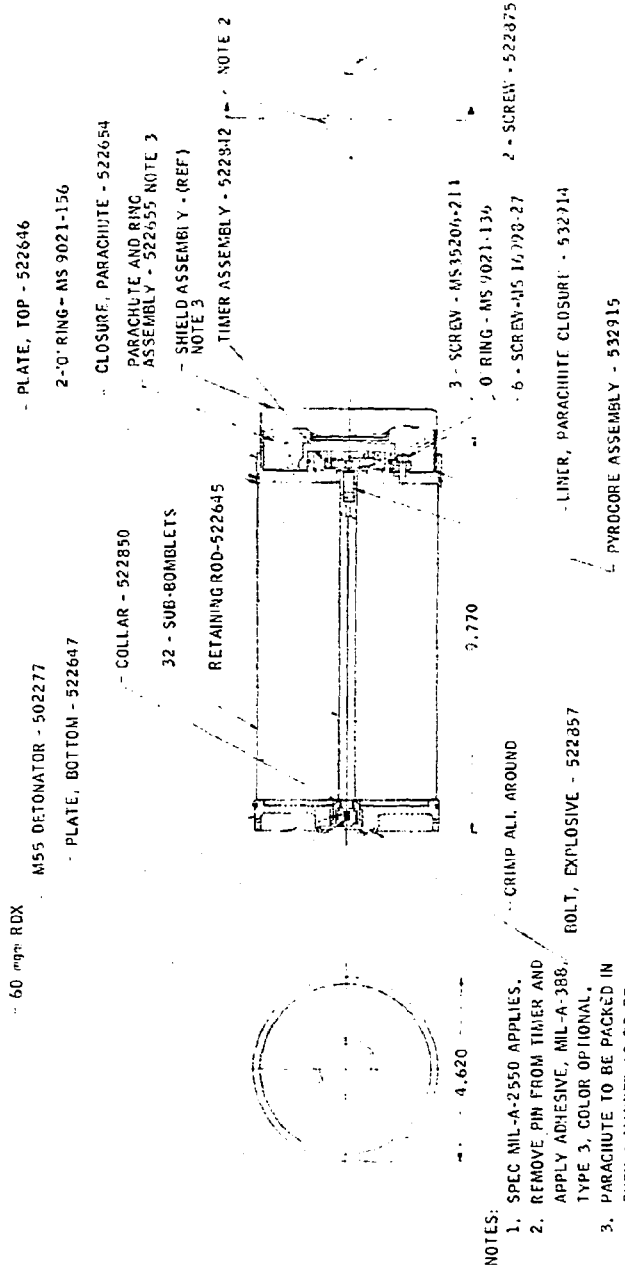

UNCLASSIFIED

Figure 5. Nonhazardous Bomblet Design

CONFIDENTIAL
(This page is Unclassified)

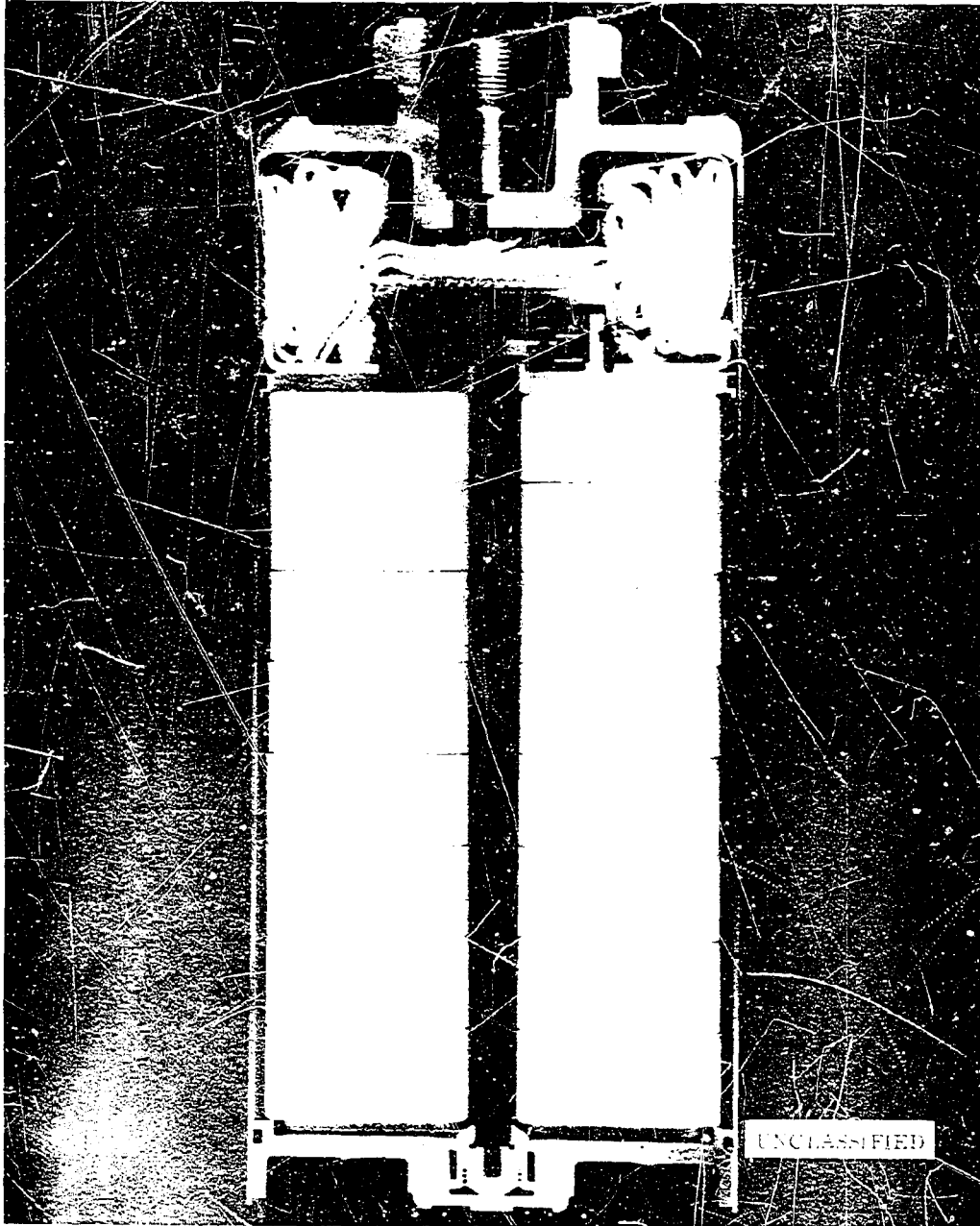
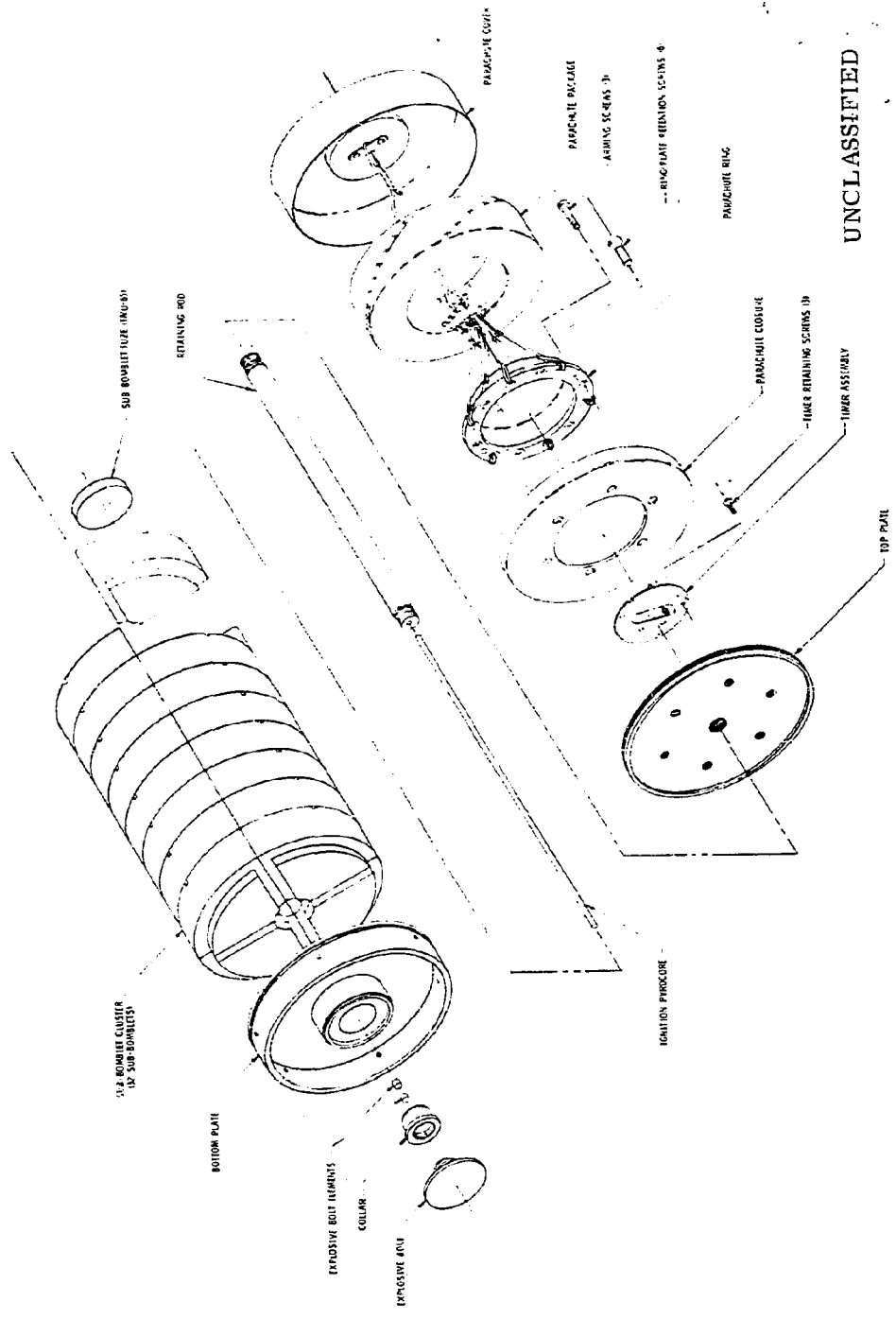

Figure 6. BLU 30/B Bomblet Display Model



UNCLASSIFIED

Figure 7. Assembly Diagram, BLU-30/B Bomblet

CONFIDENTIAL

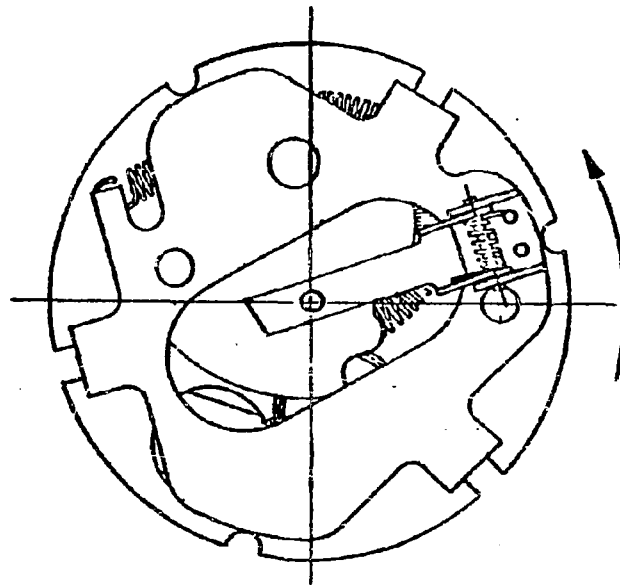

STORED ENERGY FIRING PIN ASSEMBLY

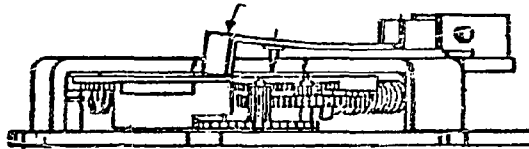

UNCLASSIFIED

Figure 8. Modified BLU-4 Timer

CONFIDENTIAL

(This page is Unclassified)

CONFIDENTIAL

2. Sub-Bomblet

(C) The final sub-bomblet design is shown in figure 9. The characteristics of the sub-bomblet are as follows:

Height	1.065 in.
Configuration	90° segment of 4.6-inch circle
Material	X-27 Cycolac (ABS Plastic)
Payload Volume	40 cc
Weight	0.18 lb
Fuzing	Modified FMU-65/B Fuze initiates thermal dissemination at agent pyrotechnic mix immediately upon target impact.

The sub-bomblet consists of a cup and cover. After the sub-bomblet cup is filled with the agent pyrotechnic mix, the cover is sealed in place with adhesive, and the modified FMU-65/B fuze is installed.

(U) The FMU-65/B is shown in figure 10. It has the following characteristics:

Safety and Arming	Spring-loaded rotor lock pin which rides the surface of adjacent sub-bomblets
Arming Delay	0.5 ± 0.1 sec.
Fuze Dimensions	0.3-in. thick and 1.2-in. diameter
Fuze Weight	13 grams
Actuation	Omni-directional ball-sear mechanism
Output	Flame from XM91 primer
Theoretical Sensitivity	100 - 200 g's impact

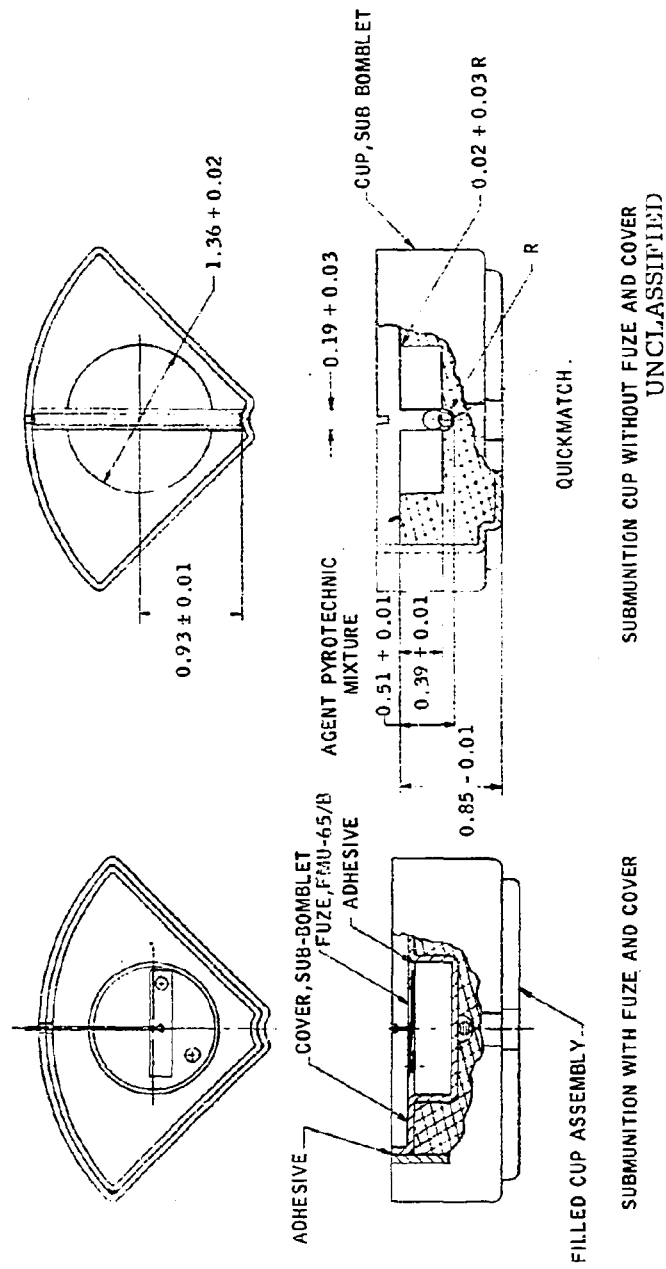
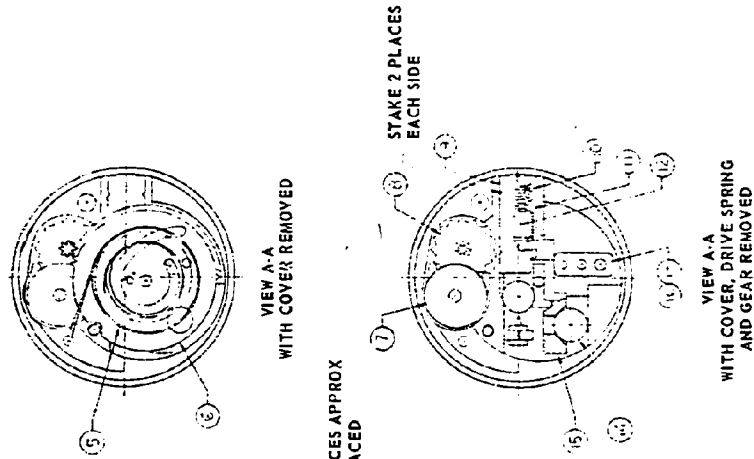

Figure 9. Sub-bomblet Configuration



- NOTES:-
 1 - SPEC MIL-A-2550 APPLIES.
 2 - APPLY COATING COMPOUND, SPEC MIL-C-450 TYPE I.

ITEM	PART NUMBER	DESCRIPTION
17	28000530	COVER ASSEMBLY
16	28000518	LATCH ASSEMBLY (ALTERNATE FOR ITEM 13)
15	28000239	SEAR
14	MS19062-5	BALL
13	28000228	LATCH
12	28000231	DETONATOR
11	28000234	SLEEVE
10	28000232	SPRING
9	28000233	COVER, SLEEVE
8	28000237	STARWHEEL ASSEMBLY
7	28000236	VERGE ASSEMBLY
6	28000222	GEAR
5	28000230	SPRING, DRIVE
4	28000260	SEAL
3	MS9486-09	PIN, SAFETY (9.9625 DIA X 9.625 LONG)
2	28000223	COVER, HOUSING
1	28000238	HOUSING & FIRING PIN ASSEMBLY

UNCLASSIFIED

Figure 10. FMU-65/B Fuze

(U) The FMU-65/B fuze operates as follows: In the unarmed condition, the spring-loaded safety pin prevents the timing gear from turning. The timing gear covers the output hole and locks the sensing lever so the primer cannot be released and subsequently initiated. After the safety pin is released, the spring-loaded timing gear is free to drive the timing gear. The timing gear is part of an untuned escapement mechanism that requires 1.0 second to complete its cycle. As the gear reaches its terminal position, it cams the safety detent from the safe to the unlocked position. This action frees the inertial sensing lever so that it will respond to an impact and cause fuze function.

(U) After fuze arming is complete, and if the sub-bomblet experiences an impact greater than 200 g's, the fuze will function and thus provide a flash output for ignition of the sub-bomblet fill. A ball and sensing lever mechanism enables fuze function for any impact orientation. The lever has a spoon shaped end which holds the ball against the fuze case. For all impact directions other than a small cone of directions directly into the fuze case, the ball moves in the direction of the force vector. As the ball moves, it either moves out of the spoon in the lever, forcing the lever to pivot about the post, or it pushes directly against the lever, again forcing it to pivot about the post. For the small cone of impact directions in which the ball is forced directly against the case (thus preventing movement in any direction), the lever accomplishes its own movement. The lever is free to move and pivots about the ball. To prevent the ball and lever from having negating moments, the c. g. of the lever is directly over the pivot post, so a given impact will not cause the lever to have a moment about the post which might act against the moment caused by the ball. As the lever moves, it disengages from contact with the primer holder. The primer holder containing the primer is held against the lever by the primer spring. The lever end which engages the holder is curved so only sliding friction occurs as the lever moves away from the holder. Thus, the lever need not overcome a primer spring force to accomplish fuze function; overcoming a primer spring force would decrease the sensitivity of the fuze. After the lever releases the primer holder, the primer spring forces the primer (and the primer holder).

against the firing pin to initiate the stab primer. The primer provides a flash output which ignites the sub-bomblet fill.

B. OPERATION

(U) The operational sequence of the nonhazardous bomblet is depicted in the flow diagram of figure 11. Upon bomblet ejection, the parachute cover acts as a drogue to deploy the cruciform parachute. The parachute is deployed within 0.2 second after bomblet ejection. When the parachute opens, sufficient force is exerted on the parachute-fuze ring to fail the two arming screws.

(U) This action withdraws a pin from the BLU-4 fuze rotor, thus initiating the fuze arming sequence. After 0.45 second, the fuze, which has a stored energy firing pin, functions and ignites the pyrocore column that extends the length of the center retaining rod. The pyrocore flashes down to the bottom of the bomblet where it initiates the explosive bolt. The explosive bolt shears a small retaining collar which allows the bottom plate to extend 0.30 inch. This extension allows the 32 sub-bomblets to be released from the cluster. Once the sub-bomblets are free of the cluster, the spring-loaded arming pin of each sub-bomblet fuze retracts from the fuze, thus initiating the 1.0-second sub-bomblet arming cycle. After fuze arming and immediately upon ground impact, the omni-directionally sensitive fuze ignites the sub-bomblet fill. The agent cloud is thermally generated for approximately 20 seconds.

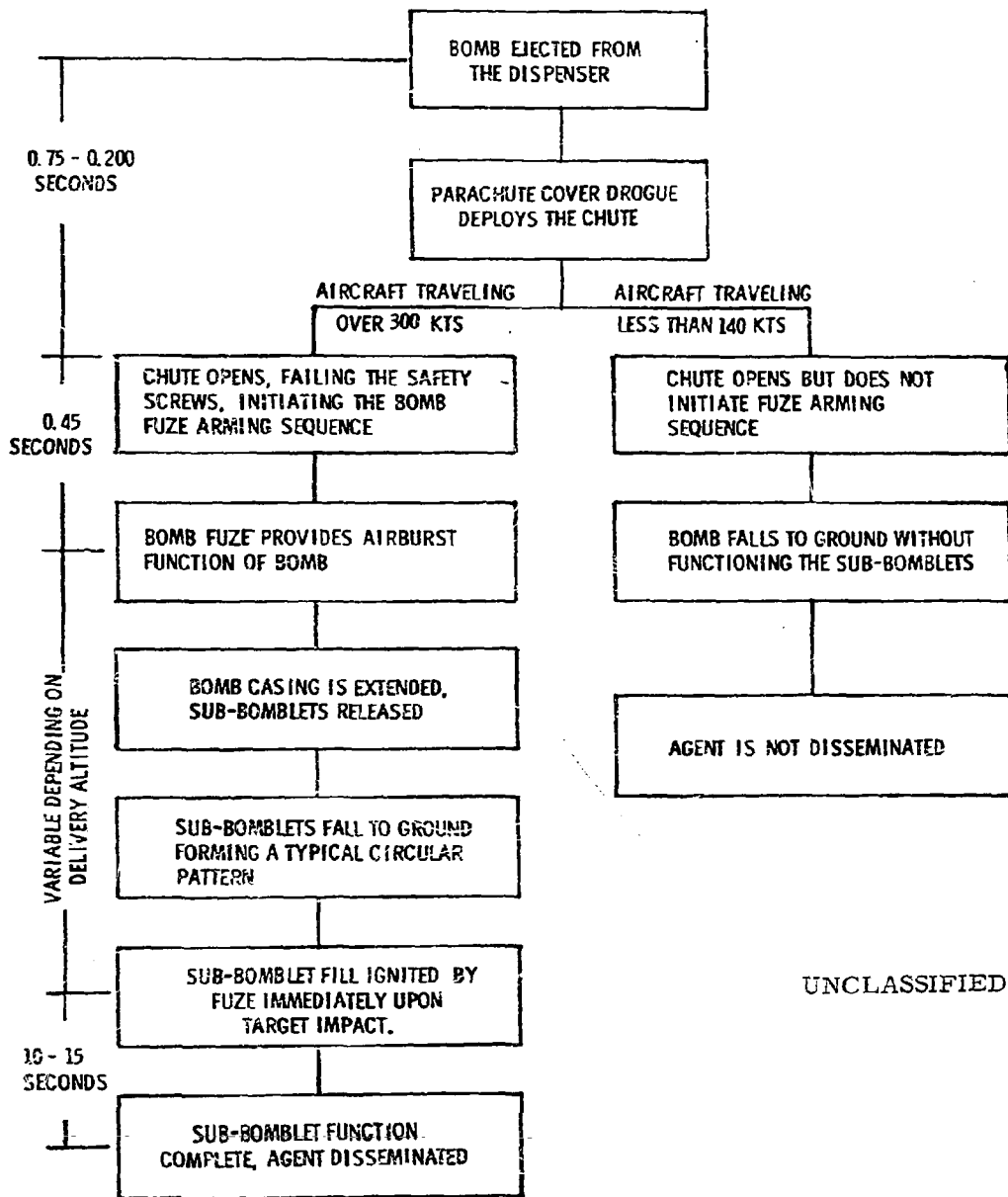

Figure 11. Bomblet Function Sequence

SECTION V
TECHNICAL DISCUSSION

A. SELECTION OF DESIGN

(U) The final nonhazardous bomblet design described in Section IV was selected on the basis of the results of the following investigations:

- . Literature Search
- . System Effectiveness Analysis
- . Fuzing Analysis
- . System Hardware Improvement Study
- . Product Engineering Review

These investigations include complete analyses of the non-hazardous bomblet designed by Honeywell under contract AF08(635)-4943 and a similar non-hazardous bomblet developed by Aerojet. A major consideration throughout these investigations was optimization of the operational effectiveness of the system in terms of the overall bomblet cost and the non-hazardous requirements. The studies showed that a parachute-decelerated cluster of 32 individually fuzed sub-bomblets would be the most effective design configuration.

1. Literature Search

(U) Literature searches were conducted (for the purpose of obtaining the most current data relative to the following; the effects of bomblet impact on target personnel, and the optimum formulations for thermal dissemination of CS and BZ agents. The literature was also reviewed for data describing the retardation capabilities of parachutes.

CONFIDENTIAL

(U) a. Effects of Bomblet Impact on Target Personnel - A search was conducted to assemble the most pertinent data relative to the survival capability of the human skull in an impact environment. The search revealed a study entitled "Studies on Skull Fracture, with Particular Reference to Engineering Factors," by Gurdjian, Webster, and Lissner, which concluded that 33 foot-pounds is the maximum impact force the human skull can withstand without fracturing. This conclusion was based on data obtained by dropping cadaver heads onto steel plates and then examining the heads to determine if skull fracture had occurred. The results of this study were used in determining the configurations and the maximum impact velocities of the parachute-deceleration cluster and the sub-bomblets.

(U) b. Optimum Formulations for Thermal Dissemination of CS and BZ Agents - BZ is classified as a military incapacitor. It is a very potent compound employed in chemical munitions to produce mental and physical incapacitation. This agent affects the central nervous system, as well as the organs of circulation, digestion, salivation, sweating, and vision. BZ in the form of an aerosol enters the body by inhalation. In dosages of approximately 100 mg-min/m³, it becomes effective from 30 to 60 minutes after exposure, and its maximum effect would be reached in 4 to 8 hours. CS is classified as a riot control agent. It is a malononitrile which produces instantaneous incapacitation at very low exposure levels (10 - 20 mg-min/m³) through severe irritation of the eyes, nose and throat. This agent has a comparatively short effective duration of 5 to 10 minutes.

(C) A summary of the search for improved agent pyrotechnic formulations along with the recommendation made is given in appendix B. Pertinent data relating to the performance characteristics of pressed pyrotechnic mixtures were obtained from the results of studies conducted by WDEL, IIT Research Institute, Dow Chemical Corp., and Atlantic Research Corp.

CONFIDENTIAL

(U) In addition to studies of various pressed mixtures, castable pyrotechnical formulations predicated upon solutions of polyurethanes and methylene chloride were developed for thermal dissemination of agents CS and BZ. Because all the so-called improved CS and BZ formulations were still in early developmental stages, it was concluded that only the standard Chemical Corps pyrotechnical formulations for BZ and CS would be used in this program.

(C) Most recent thermal generation tests using the standard pressed mixes have indicated 60 to 65 percent agent recovery for BZ, and up to 70 percent for CS. The standard mixtures are as follows:

CS: Chem Corps B143-14-7, which consists of --
40% CS per MIL-C-51029 (by weight)
12% Magnesium Carbonate
27% Potassium Chlorate
18% Sugar, Type I per JJJ-S-791
3% Nitrocellulose Binder

BZ: Edgewood Arsenal Hooker 283 (in lieu of the Standard CHM Corps B143-14-6), which consists of --
55% BZ
20.25% Potassium Chlorate
7.95% Sulphur
6% Sodium Bicarbonate
10.8% 283 Resin
0.105% Methyleneethyl Ketone Peroxide
0.0135% Cobalt Napthanate
Acetone Binder to 5.2% of dry weight

CONFIDENTIAL

Ignitor or Starter Mixture: Either Quickmatch per MIL-Q-378B, or Chem Corps B143-7-3, which consists of --

43% Potassium Chlorate
15% Sulphur
32% Sodium Bicarbonate
10% Cornstarch

(U) c. Retardation Characteristics of Parachutes - A thorough literature search and performance characteristics analysis were conducted on various candidate parachutes for use with the nonhazardous bomblet. The parachute study included investigations of performance characteristics, packing efficiency, and cost. Four parachutes were considered; guide surface, ring vortex, cruciform, and ribbon type.

(U) The guide surface chute has a very high degree of stability (the best of the four originally considered,) but because of its low packing efficiency and unpredictable oscillations and high shock loads during opening, it was rejected.

(U) The ring vortex parachute was also rejected because of its inherently high torsional opening shocks and unpredictable opening characteristics. The opening characteristics of the parachute are very important for this bomblet design because they have a direct relationship to the short, safe/arming sensing mechanism. Upon comparing the opening characteristics of the ribbon and cruciform parachutes, the cruciform chute was recommended. The complete details of the parachute study are included in appendix A.

2. System Effectiveness Analyses

(U) A cluster bomblet the size and shape of the sub-bomblet dictates

CONFIDENTIAL

the effectiveness of the cluster bomblet system. Five sub-bomblet designs were studied (see configurations in figure 12). Concept I was shown to be the most effective in terms of area coverage and overall system cost. The pie shaped geometry was the only one considered because of its packaging efficiency in the circular confinement of the ŠUU-13/A dispenser tubes.

(U) Each of the candidate sub-bomblet designs were analyzed for area coverage characteristics and the effect on bomblet cluster cost. Only concept I was selected. It was further studied to determine the optimum delivery altitudes and velocities for clusters of sub-bomblets filled with CS and BZ agents. These studies are detailed below.

(U) a. Area Coverage Analyses - A model was constructed which accurately (within a limited time frame) predicted the dosage contours resulting from the five sub-bomblet designs considered. The model was derived from the G. H. Milly study² and associated definitions³. The model was applied to the thermally generated sources by altering the parameters of source time (dissemination time for each sub-bomblet was assumed to be from 10 to 20 seconds) and the distribution of the resulting agent cloud.

(C) (1) Development of Theoretical Dosage Patterns - The theoretical patterns for the sub-bomblet were determined by the Milly equation shown below:

$$\frac{Du}{q} = \frac{1}{\pi \sigma_y(x) \sigma_z(x)} \exp - \frac{h^2}{2\sigma_z^2(x)} \left[1 - \operatorname{erf} \frac{x-ut}{2\sigma_x(x)} \right]$$

²"Atmospheric Diffusion and Generalized Munition Expenditure: ORG No. 17; dated January 1962.

³Chemical and Biological Weapons Technical Reference Handbook, U. S. Army Chemical, Biological and Radiological Research Group, Edgewood Arsenal, Maryland, 1963.

CONFIDENTIAL

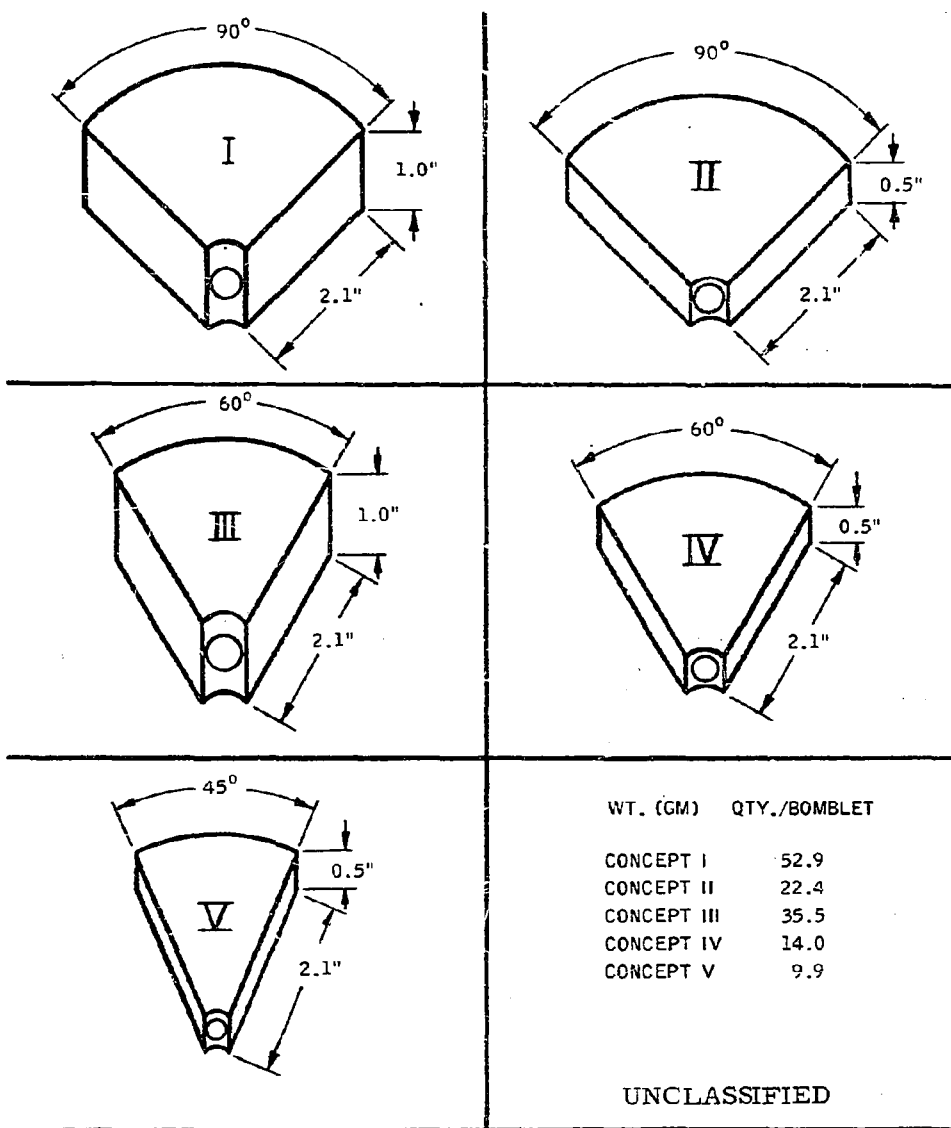

Figure 12. Sub-bomblet Candidate Designs

CONFIDENTIAL

where:

D = the dosage at a point (x, y) (mg-min/m³)

u = the wind speed (m/min)

q = the quantity of airborne agent generated by the source (mg)

$\sigma_y(x) = 3.41 (x/100)^\alpha$, the standard deviation of the agent cloud in the y direction (meters)

$\sigma_z(x) = 1.35 (x/20)^\beta$, the standard deviation of the agent cloud in the z direction (meters)

α and β = parameters describing the atmospheric stability

$\sigma_x(x) = \sigma_y(x)$ for $x \leq ut$ or $\sigma(ut)$ for $x > ut$, the standard deviation of the cloud in the x direction (meters)

h = the height of the source from the ground (meters)

t = the time after release of the agent (minutes)

(C) Use of the Milly equation is based on the assumptions that the wind direction and velocity are constant, that the agent cloud does not settle out, and that the cloud is described by the trivariate normal distribution throughout the dissemination. Application of the equation for this study required the additional assumptions that the initial rise of the warm agent cloud is equal to the sampling height (i. e., the height of a man to his nose) and that the casualty rate of the agents is dependent only on the cumulative dosage.

(U) A two-part computer program was written to compute the area coverage of a bomblet. The first part of the program used the Milly equation to calculate the dosage pattern of a sub-bomblet.

(U) The second part of the program combined the sub-bomblet dosage patterns to determine the complete bomblet area coverage. The sub-bomblet impact patterns were generated by the program from the theoretical pattern limits presented in figures 13 through 15. These limits are taken to be the 95-percent limits (\pm two standard deviations) of a bivariate normally

CONFIDENTIAL

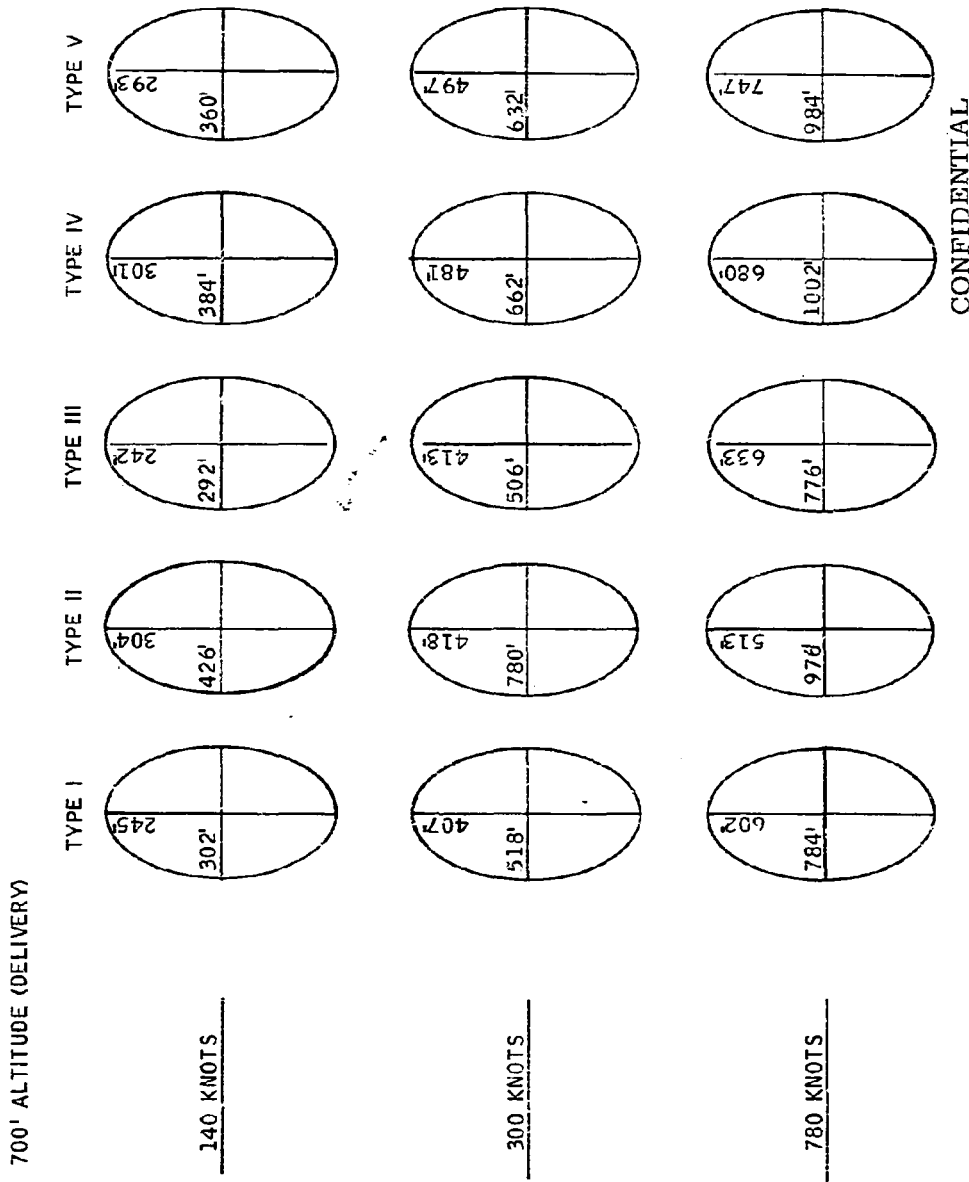

CONFIDENTIAL

Figure 13. Theoretical Cluster Patterns (Bomblet Delivered from 70-foot Altitude)

CONFIDENTIAL

CONFIDENTIAL

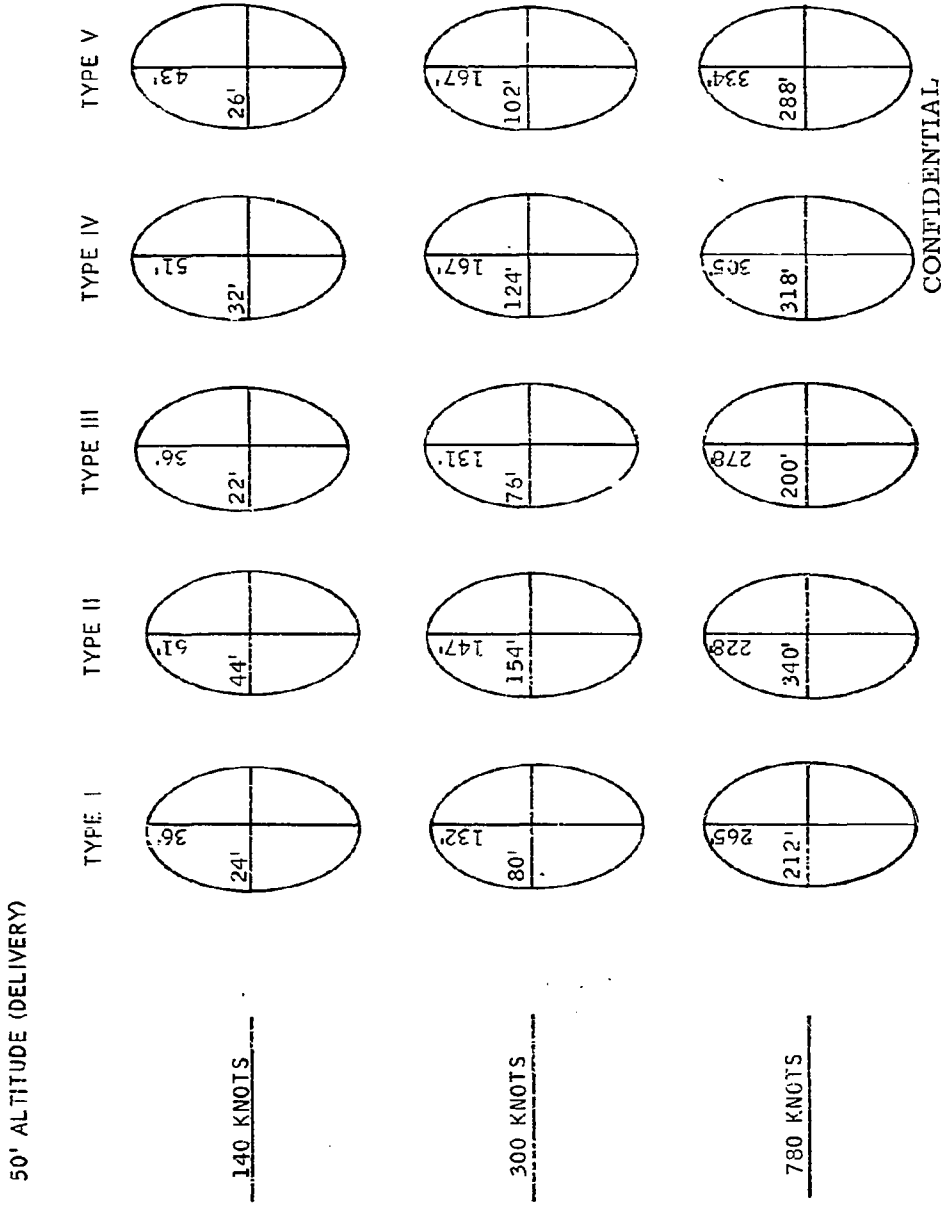

CONFIDENTIAL

Figure 14. Theoretical Cluster Patterns (Bomblet Delivered from 73-foot Altitude)

CONFIDENTIAL

CONFIDENTIAL

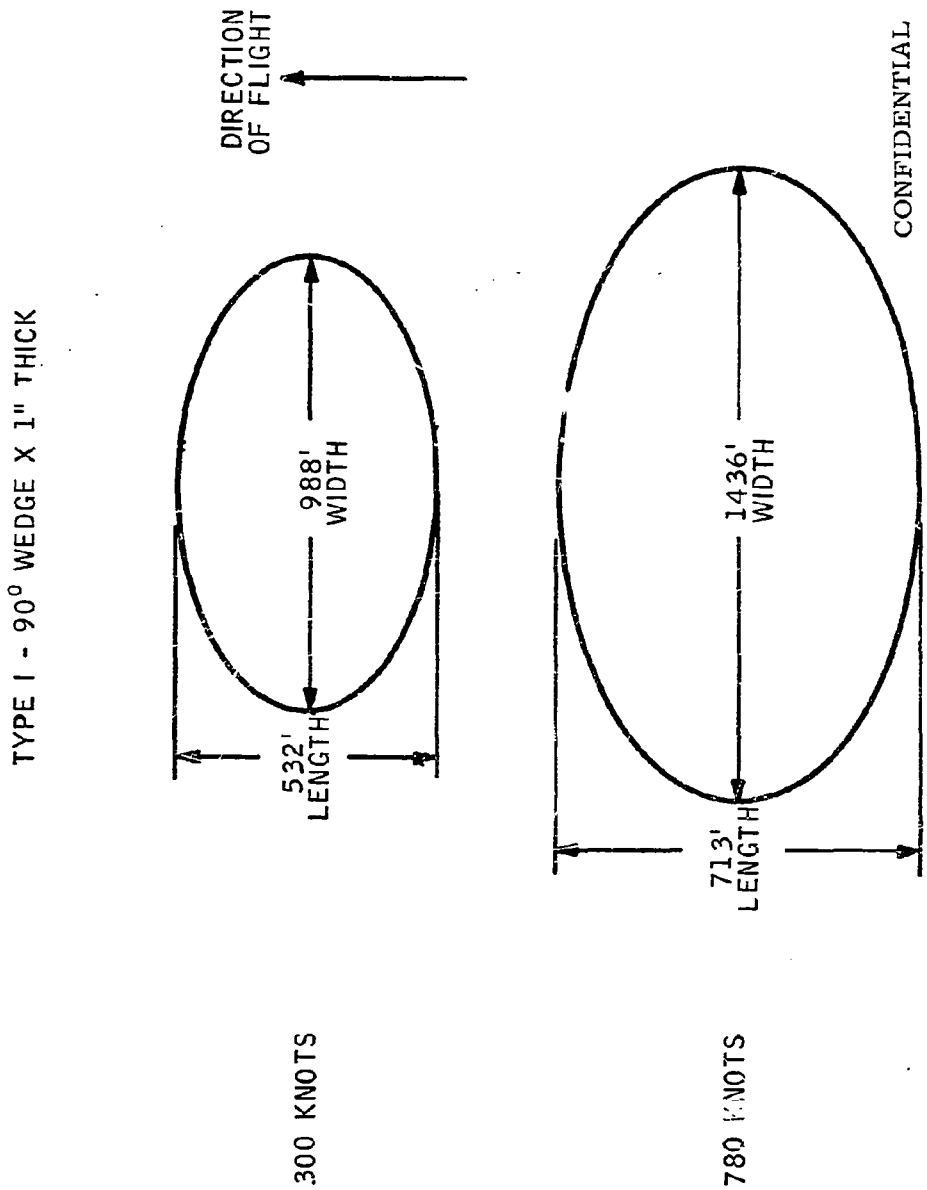

Figure 15. Theoretical Cluster Patterns (Concept I - Sub-bomblet Delivered from 2500-foot Altitude)

CONFIDENTIAL

CONFIDENTIAL

distributed pattern. The selection of a bivariate normal distribution as the most likely distribution was based on a chi-squared test of the patterns achieved in flight tests. The theoretical and test impact pattern distributions obtained for the Concept I sub-bomblet are presented in figures 16 and 17 respectively. These results are typical of the comparisons achieved for the other sub-bomblet concepts.

(C) With the impact pattern established and divided into a grid (with the cells the same size as those in the dosage patterns), the computer program calculated the dosage level for each cell in the pattern. The dosage contribution at a cell from each sub-bomblet was added; if the sum was greater than the required dosage for 30 percent casualties (ICt_{30}), the area of the cell was added to the bomblet area coverage. The sub-bomblet dosage patterns were cut off at $1/10 ICt_{30}$ because, with the number of sub-bomblets and the size of the impact patterns used, 10 is the maximum expected number of sub-bomblets which could contribute agent to a cell. Figure 18 is an overlay of the sub-bomblet ICt_{30} dosage patterns on an impact pattern. Only about 60 percent of the total area coverage is shown here because there are cells which are outside the ICt_{30} contours, but which have an accumulated ICt_{30} .

(C) (2) Pattern Evaluation - The area covered by the ICt_{30} was calculated for various sub-bomblet impact sizes to determine the optimum pattern size (see figs. 19 and 20). The maximum area coverage occurred at the intermediate pattern sizes; 2,500 m^2 for BZ and 10,000 m^2 for CS. These optimums are valid only for a single bomblet under the conditions of a neutral atmosphere and a 3-mph wind; however, the curve is relatively flat, indicating that the area coverage is not sensitive to pattern size.

(C) Because the fraction of the impact pattern covered by the 30-percent casualty contour becomes smaller as the impact pattern size increases, it would not be advantageous to use excessively large patterns, such as those obtained from high altitude, unless several bomblets with overlapping

CONFIDENTIAL

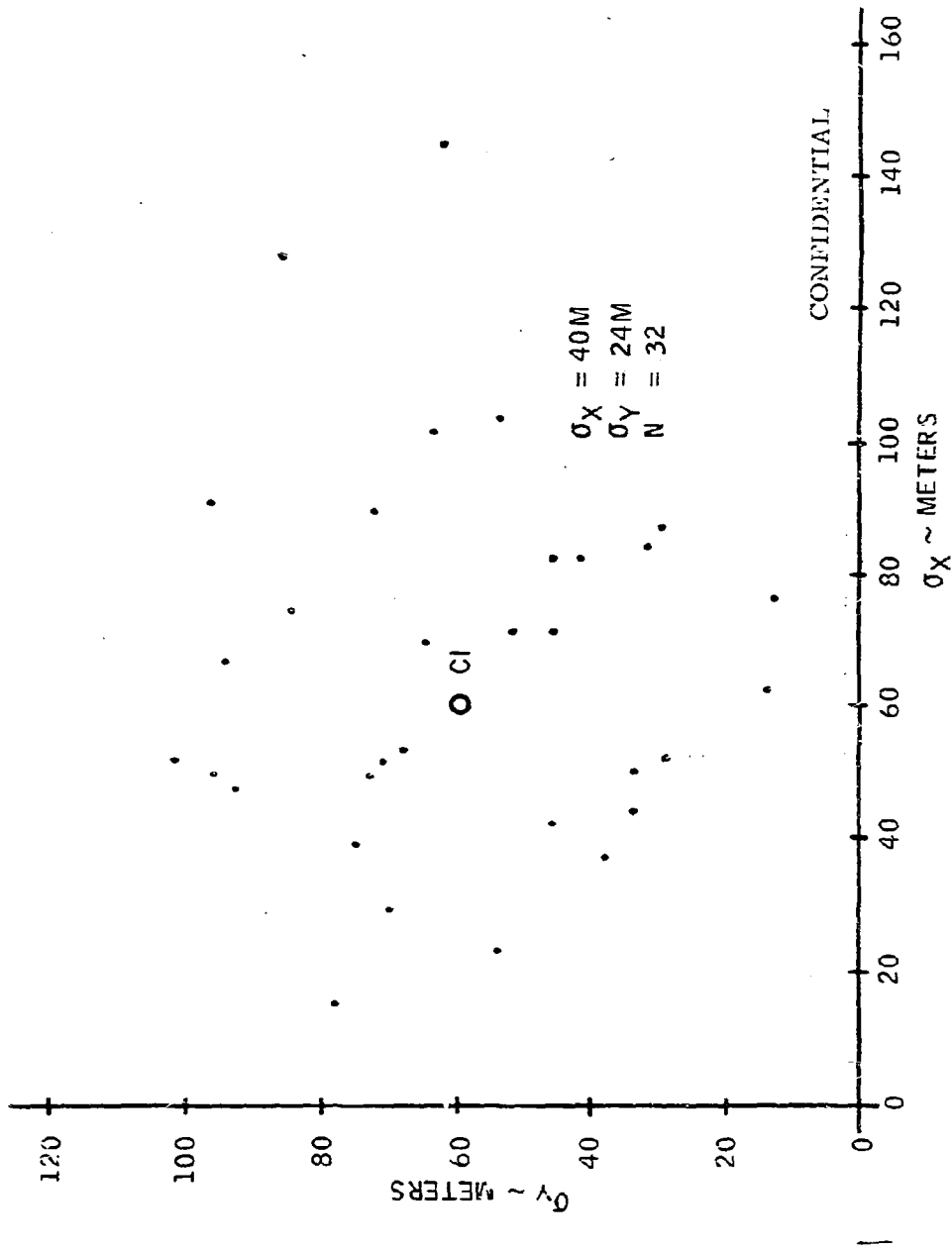

Figure 16. Theoretical Impact Pattern, Concept I.

CONFIDENTIAL

CONFIDENTIAL

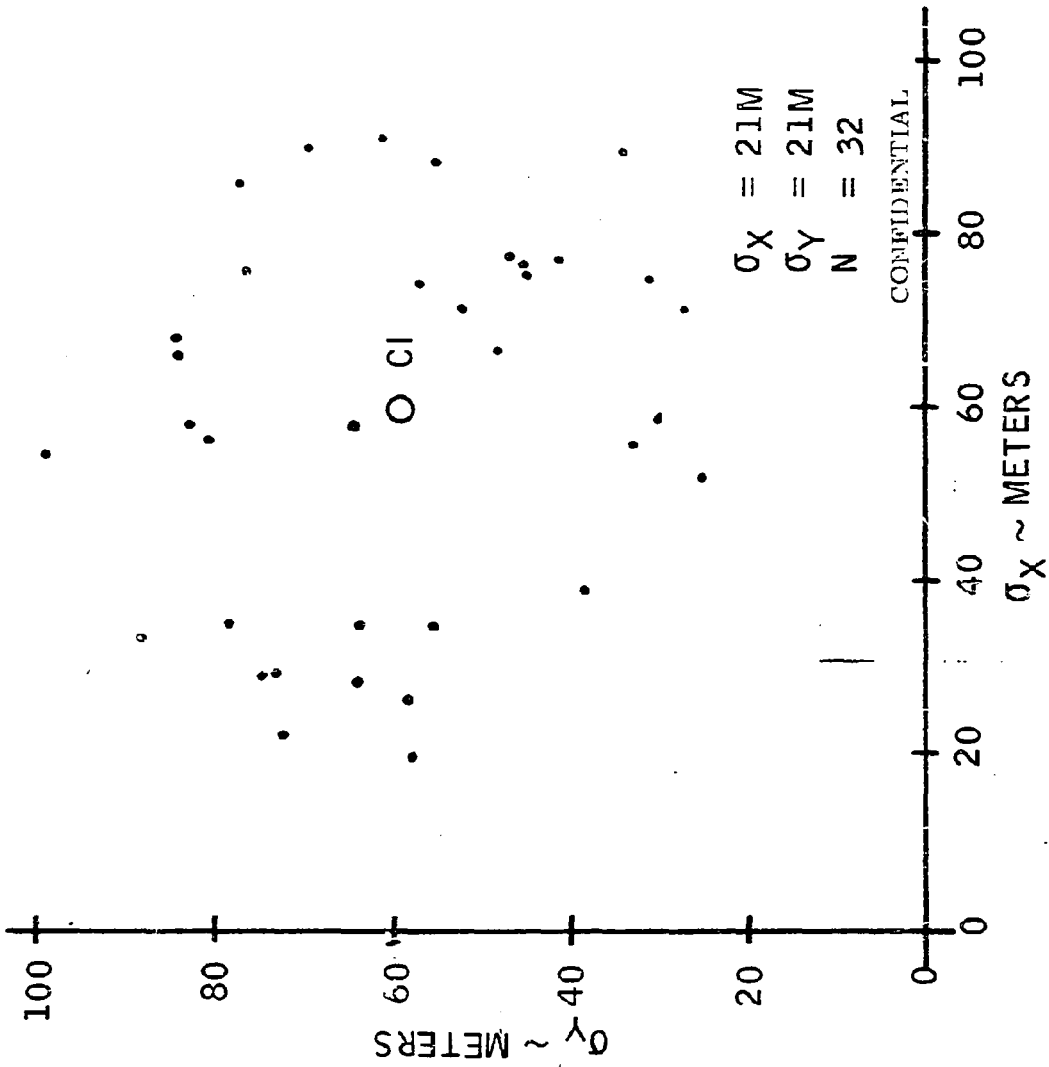

Figure 17. Test Impact Pattern, Concept I

CONFIDENTIAL

CONFIDENTIAL

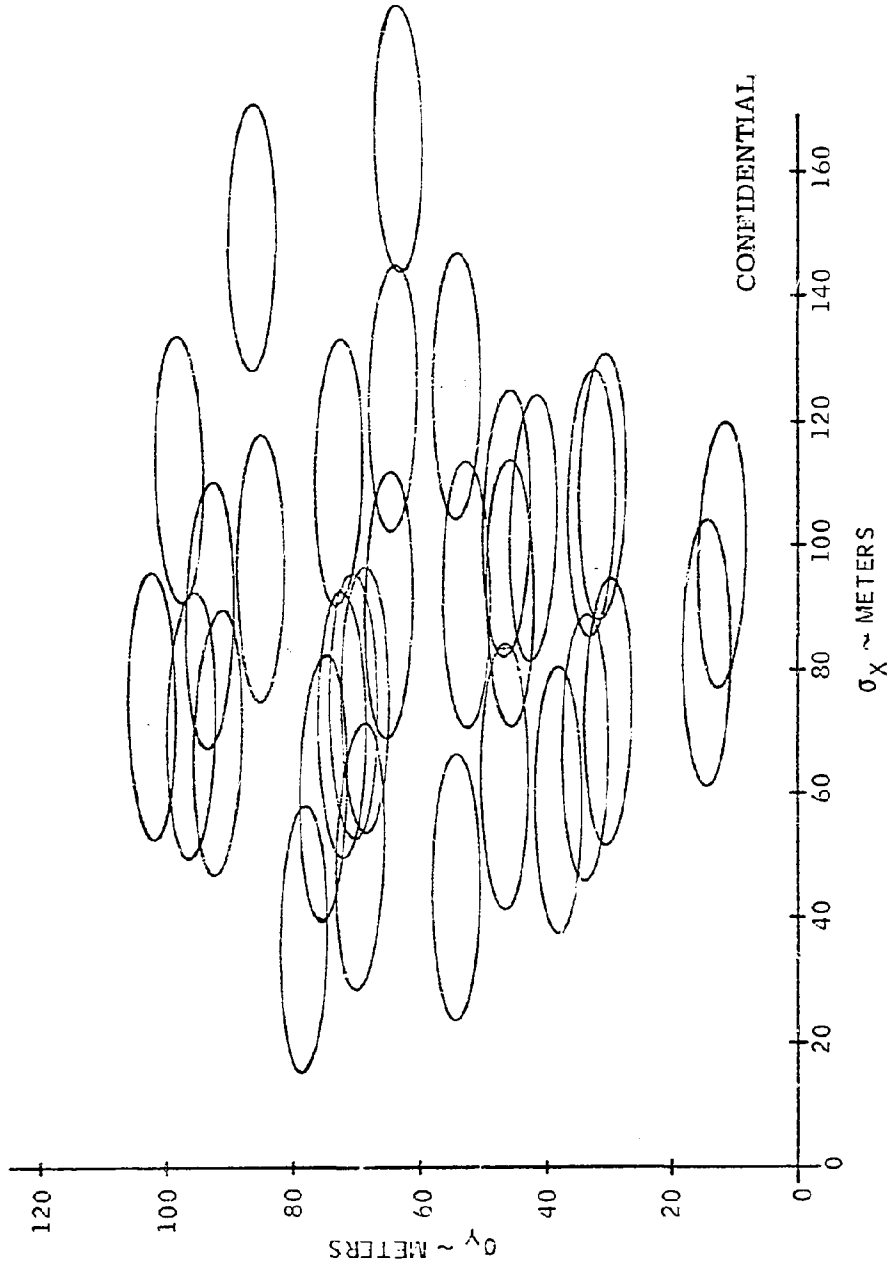

Figure 18. Thirty Percent Contour Overlay on Theoretical Pattern

CONFIDENTIAL

CONFIDENTIAL

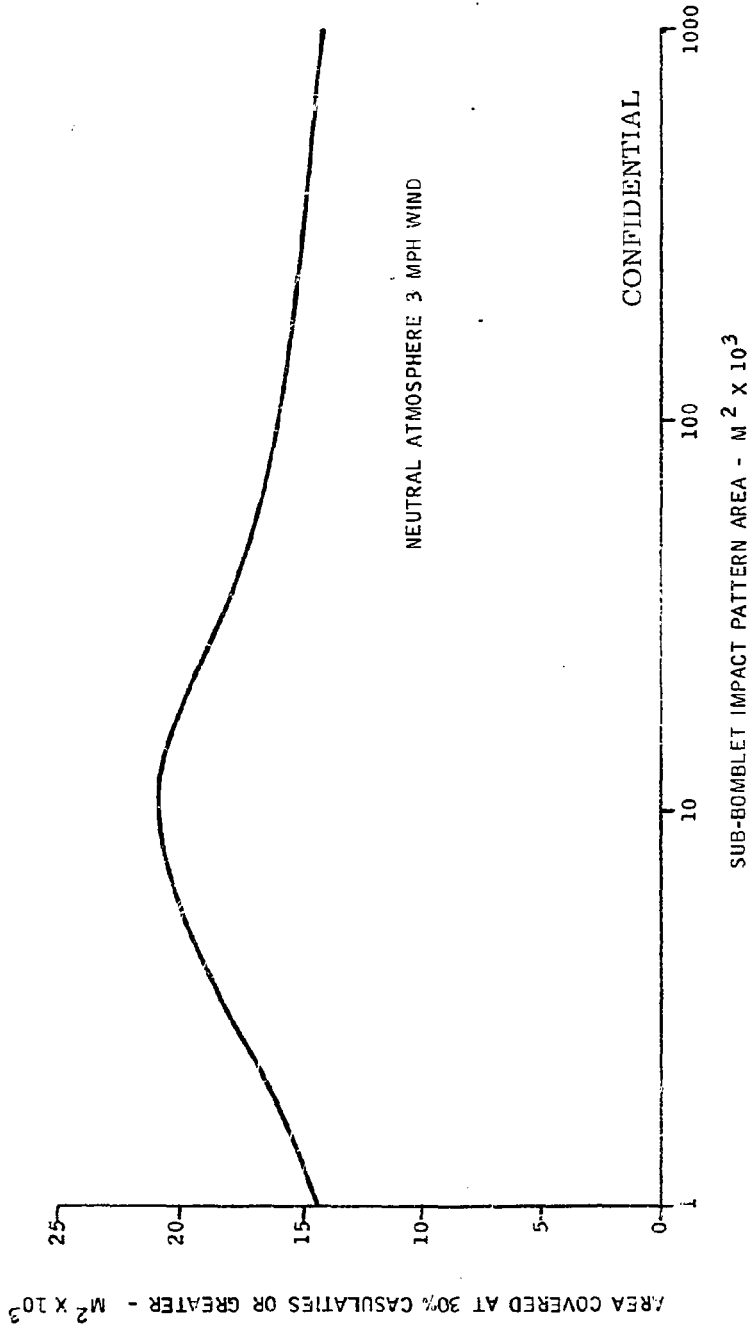

Figure 19. Area Coverage per Bomblet (CS Agent)

CONFIDENTIAL

CONFIDENTIAL

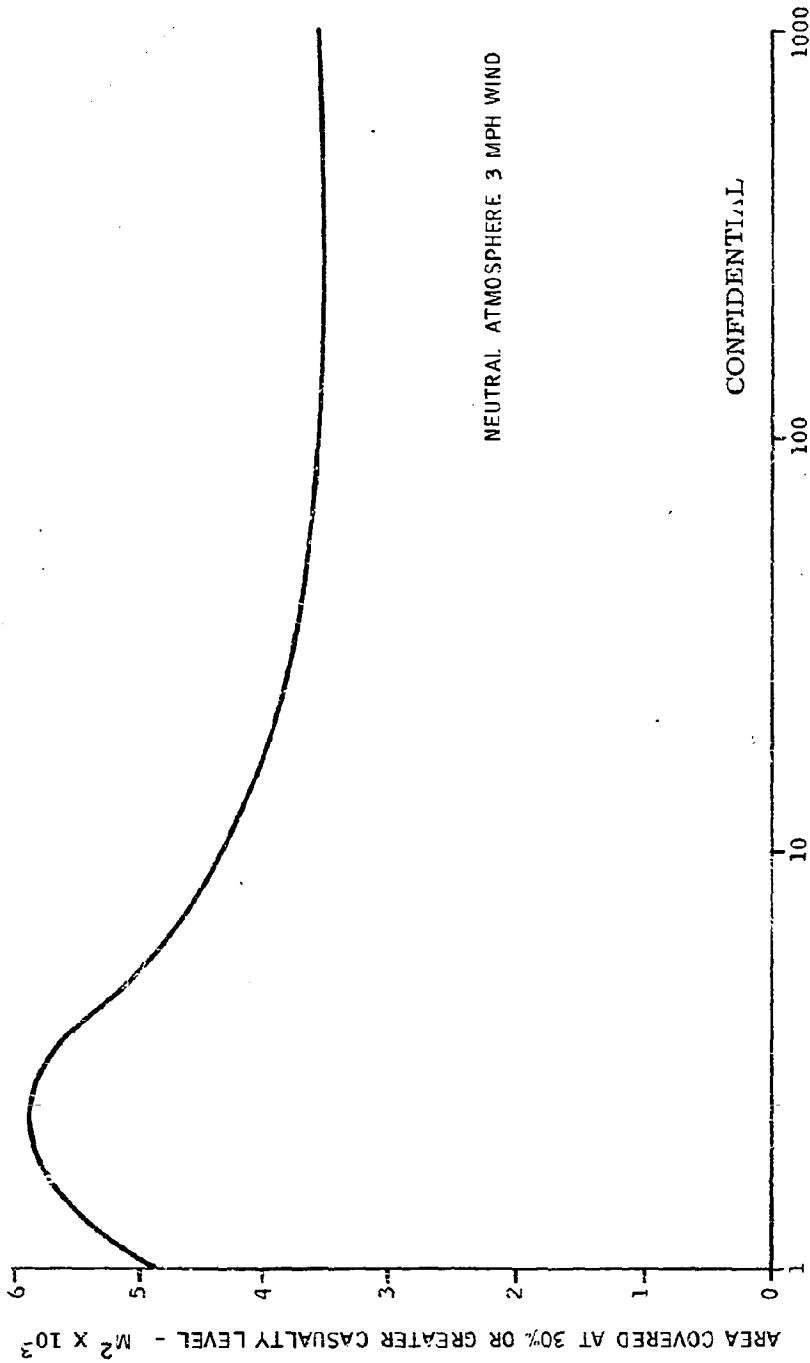

Figure 20. Area Coverage per Bomblet (BZ Agent)

CONFIDENTIAL

CONFIDENTIAL

patterns were delivered. If a fractional coverage of 0.3 is selected as being the minimum of interest, the maximum pattern size is about 12,000 m² for BZ and 50,000 m² for CS. Based on this, the pattern predicted as resulting from a release from 2500 feet (500,000 m²) is excessively large.

(C) (3) Calculation of Area Coverage for All Concepts - Computer runs were made to calculate the area coverage of the five concepts employing CS and BZ. The results, summarized in figure 21 through 24, indicate that Concept I has equal or better area coverage than the other concepts. Impact patterns simulating deliveries from a 50-foot altitude at 300 knots and from a 700-foot altitude at 780 knots were used in these calculations. The exact impact pattern size varies from one concept to the next, but the patterns are about 150 meters in diameter for the low-speed, low-altitude case and about 1000 meters in diameter for the high-speed, high-altitude case. Only a neutral atmosphere with a 3 mph wind is presented here; however, checks at wind speeds from 1 to 15 mph and in lapse and inversion atmospheres show no change in the rank of the sub-bomblets. The 30-percent incapacitating dosages used for BZ and CS were 96 mg-min/m³ and 4.2 mg-min/m³. The dissemination efficiency was 0.65 for BZ and 0.70 for CS.

(U) As a matter of interest, the area coverage-time relationship was examined during the study. The computer program was set up so that the sub-bomblet dosage patterns could be cut off at any distance (x) downwind. This allowed a study of the rate at which the area coverage builds up. At a time (t) the pattern was cut off at the distance (x) equal to (ut), where (u) is the wind speed. The area coverage was calculated for successive values of (t) for Concepts I and V (the extreme cases of the five concepts). The results are presented in figures 25 and 26. The calculations were made for a 3-mph wind; however, the same relationship is valid for other wind speeds since the rate of buildup is inversely proportional to the wind speed. That is, a given value of area coverage will occur in half the time if the wind speed is doubled.

CONFIDENTIAL

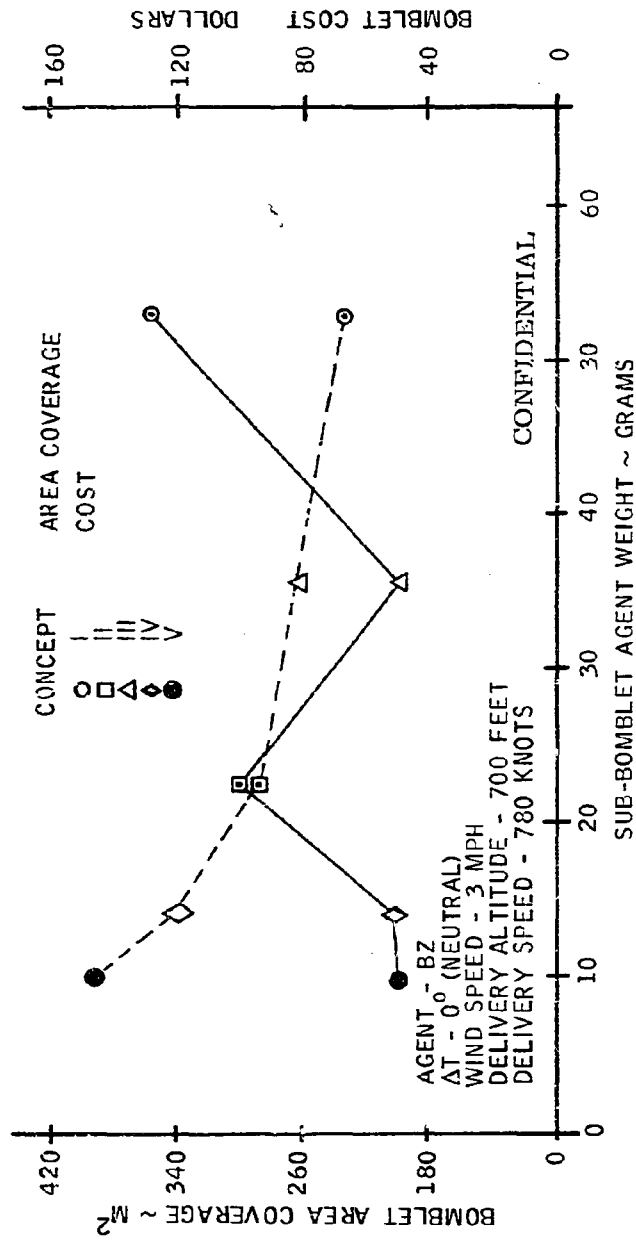

Figure 21. Area Coverage at 30% Casualties and Cost Comparison for Agent BZ

CONFIDENTIAL

CONFIDENTIAL

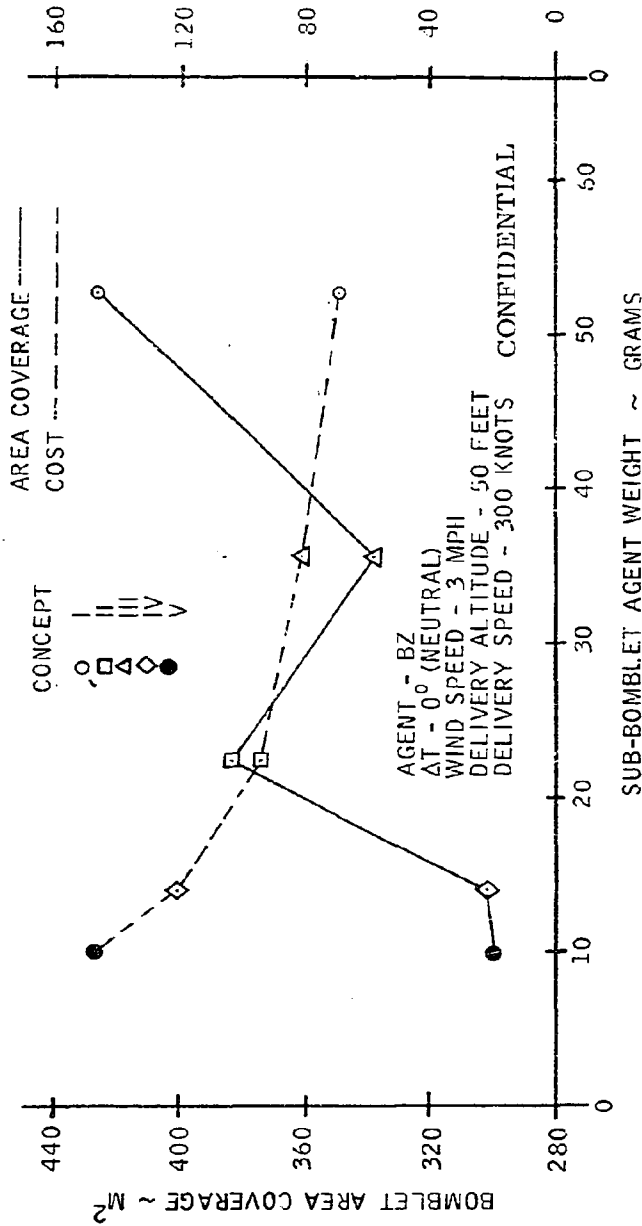

Figure 22. Area Coverage at 30% Casualties and Cost Comparison for Agent BZ, 50-foot Delivery Altitude at 300 Knots

CONFIDENTIAL

CONFIDENTIAL

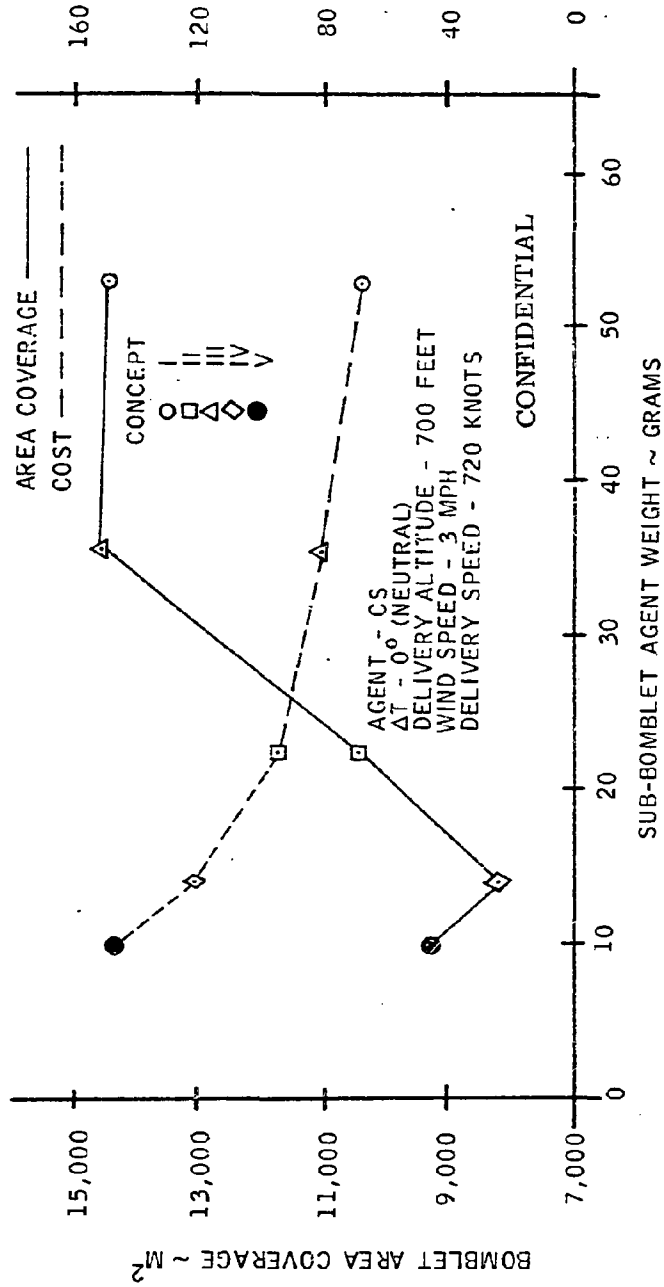

Figure 23. Area Coverage at 30% Casualties and Cost Comparison, Agent CS, 700-foot Delivery Altitude at 780 Knots

CONFIDENTIAL

CONFIDENTIAL

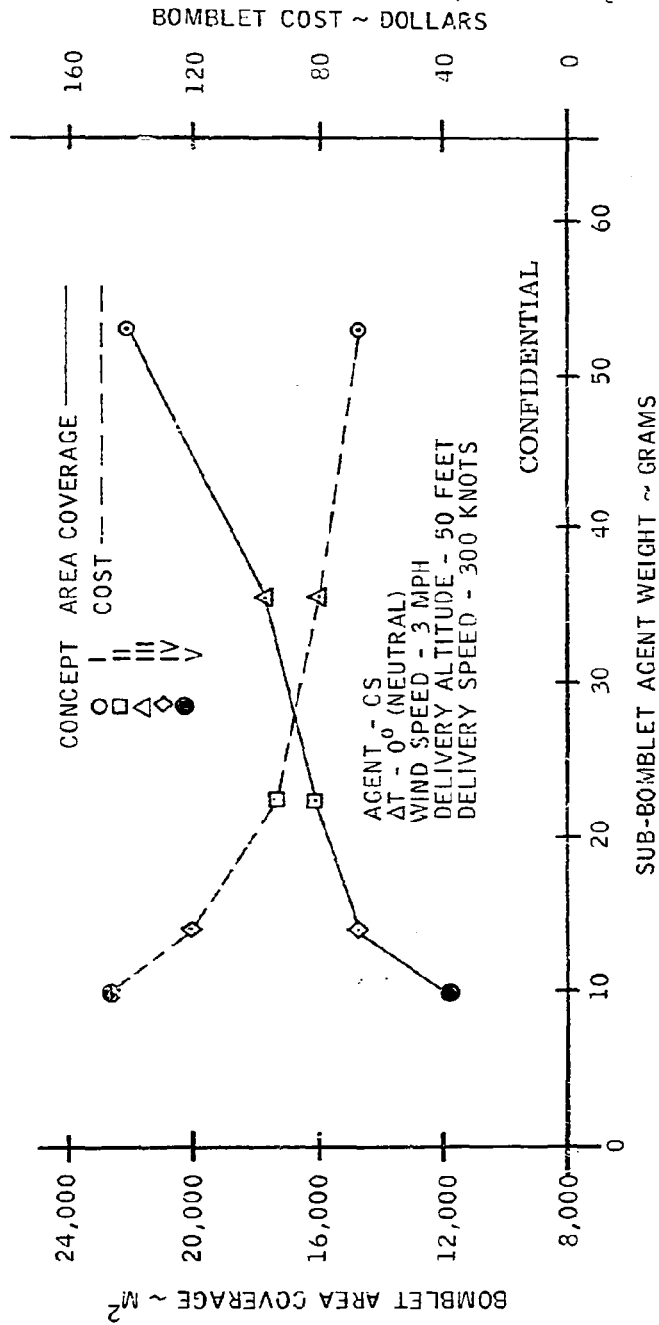

Figure 24. Area Coverage at 30% Casualties and Cost Comparison, Agent CS, 50-foot Delivery Altitude at 300 Knots

CONFIDENTIAL

CONFIDENTIAL

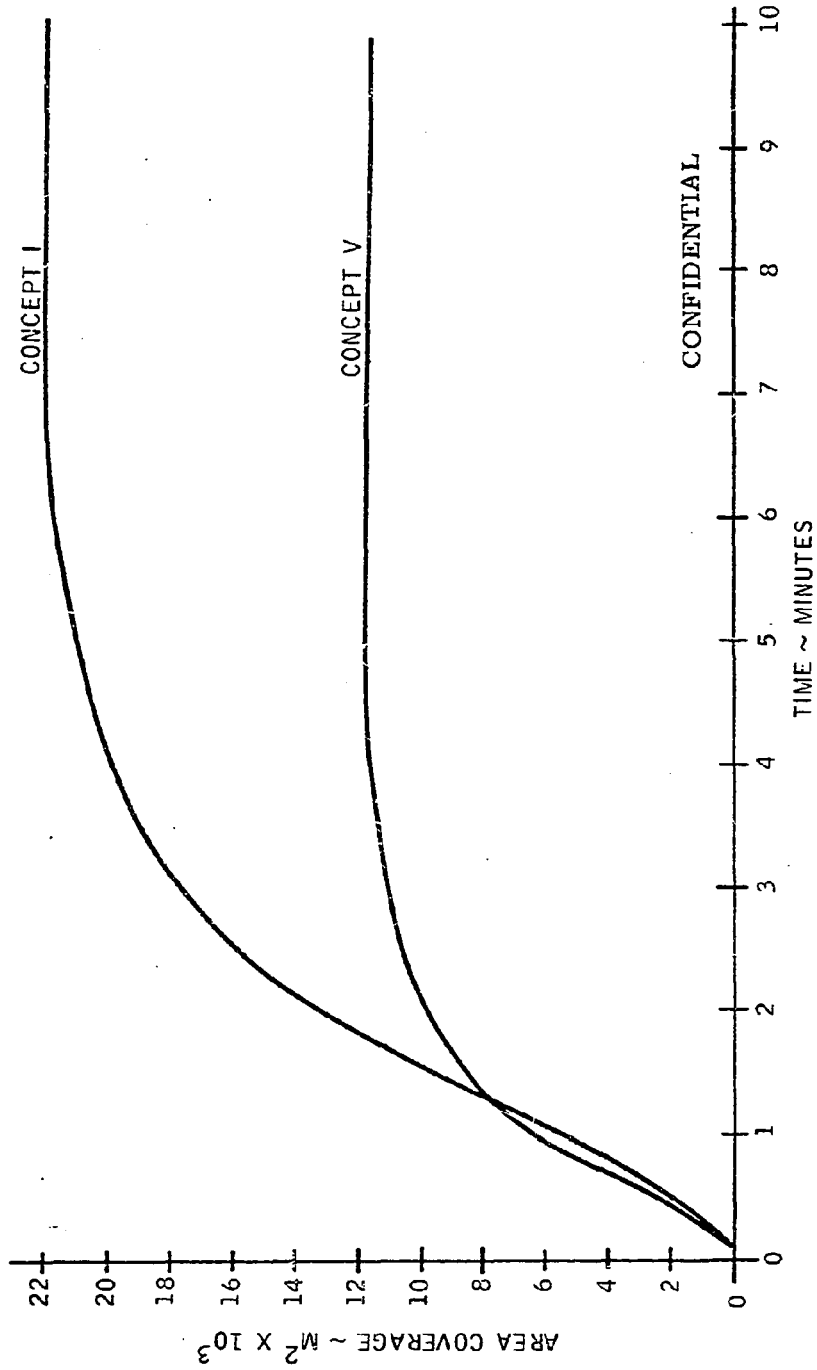

Figure 25. Rate of Area Coverage Development, Agent CS

CONFIDENTIAL

CONFIDENTIAL

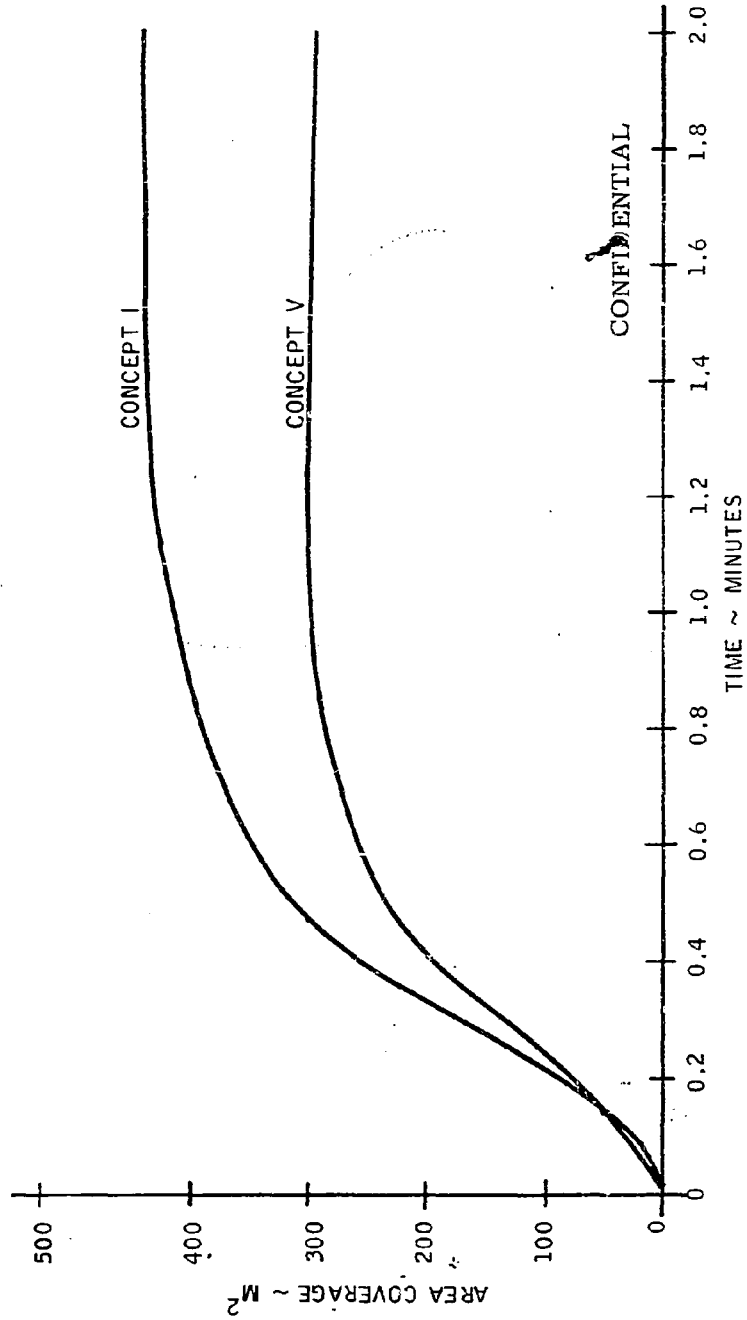

Figure 26. Rate of Area Coverage Development, Agent BZ.

CONFIDENTIAL

CONFIDENTIAL

(C) a. Summary of Cost/Effectiveness Analysis - To provide the actual costs necessary to complete the cost/effectiveness analysis, high production cost estimates (based on production quantities in excess of 5 million) were obtained for the following items:

- Complete bomblet hardware
- Bomblet assembly
- Sub-bomblet loading, fuzing, and assembly

(U) For comparative purposes, costs were obtained for the following alternative sub-bomblet assemblies for each candidate:

- Sub-bomblet with delay primer and without flotation device
- Sub-bomblet with delay primer and flotation device
- Sub-bomblet with mechanical fuze (FMU-65/B)

The results of the cost comparison are shown in figure 27.

(U) As the final step in the cost/effectiveness analysis, the theoretical measured effectiveness of each concept was combined with the actual cost of each concept. Only the bomblet hardware costs were used for this comparison since there is no difference in the sortie cost between the concepts. The data in figures 28 through 31 indicate that Concept I, with its high effectiveness and low cost, provides the optimum cost/effectiveness for the nonhazardous bomblet.

(C) b. Bomblet Application Study - The four tactical situations summarized in table I were studied to determine the appropriate bomblet requirement for each situation and the bomblets and bomblet delivery tactics that would be most effective. The study was based on the results of a comprehensive study⁴ for the U. S. Army Limited War Laboratory. CS and BZ

⁴"Application of Selected Agents to Counterinsurgency" (U), R. C. Koch and S. D. Thayer, November 1965, U. S. Army Limited War Laboratory, AD369167.

CONFIDENTIAL

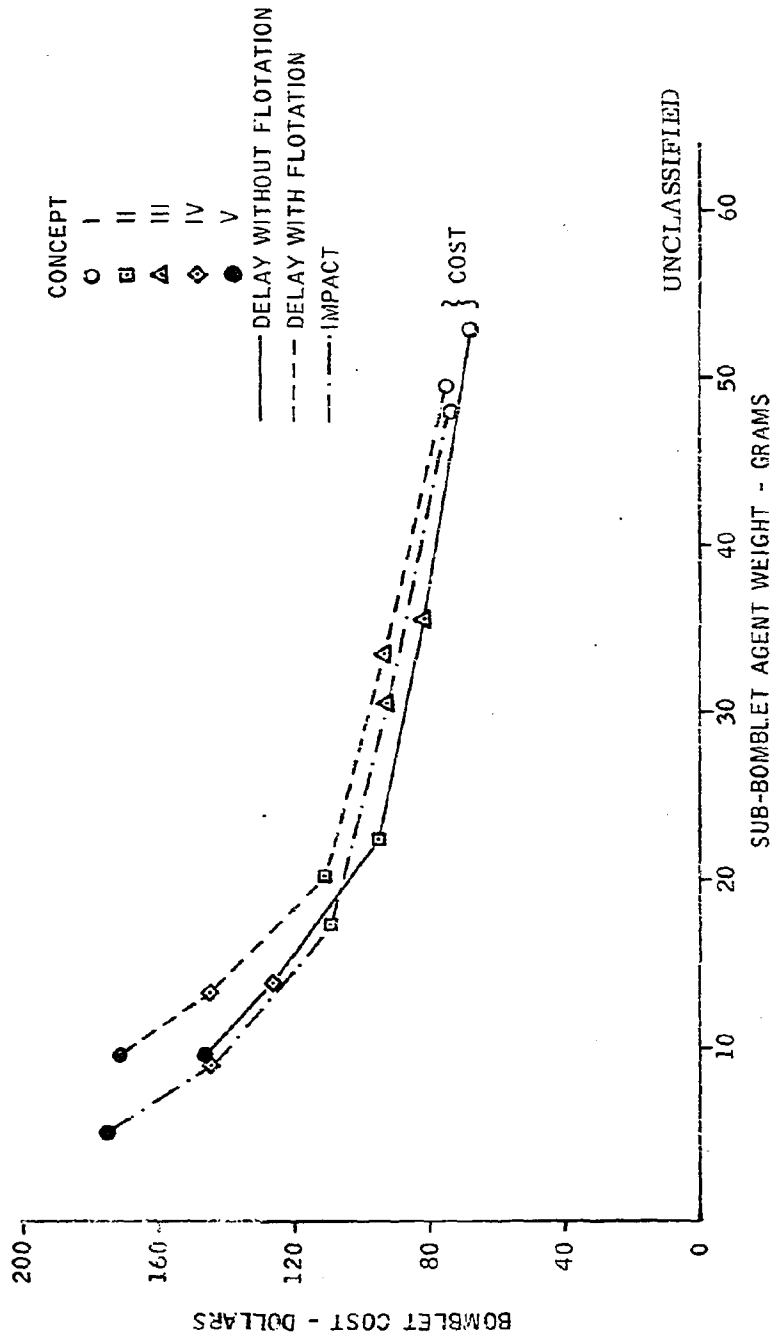

Figure 27. Bomblet Cost Comparison

CONFIDENTIAL

(This page is Unclassified)

CONFIDENTIAL

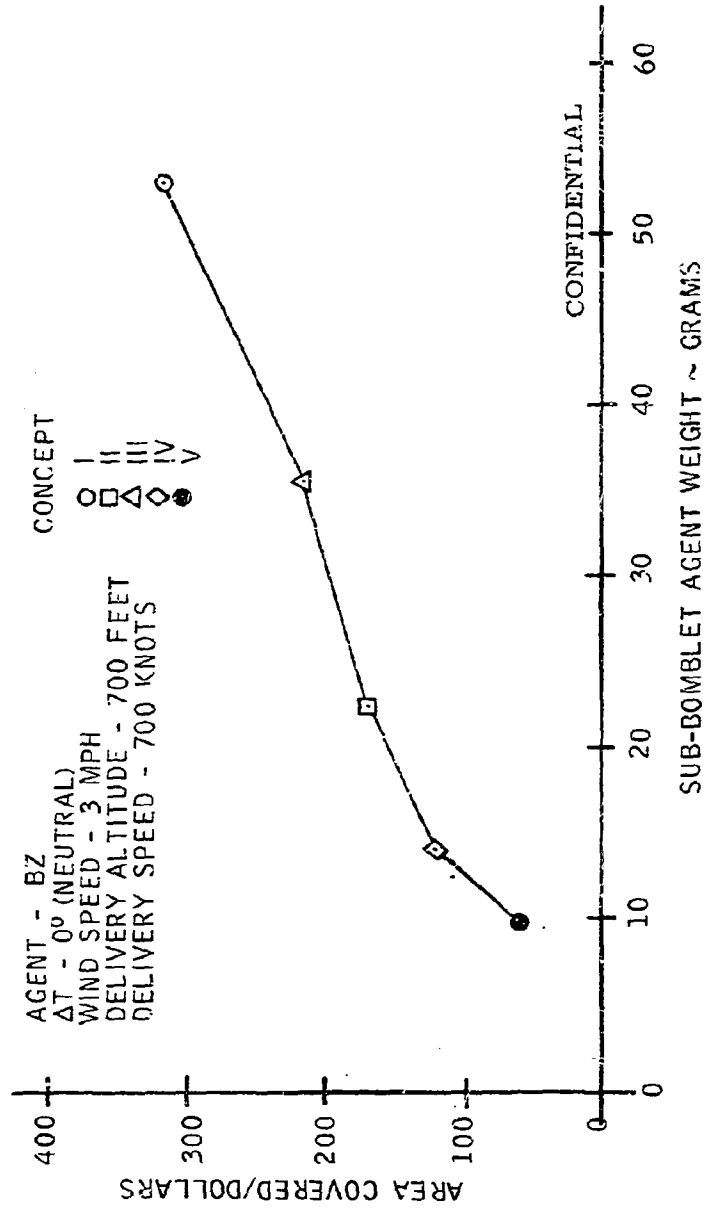

Figure 28. Cost Effectiveness Comparison at 30% Casualties, Agent BZ (700-foot Delivery Altitude at 780 Knots)

CONFIDENTIAL

CONFIDENTIAL

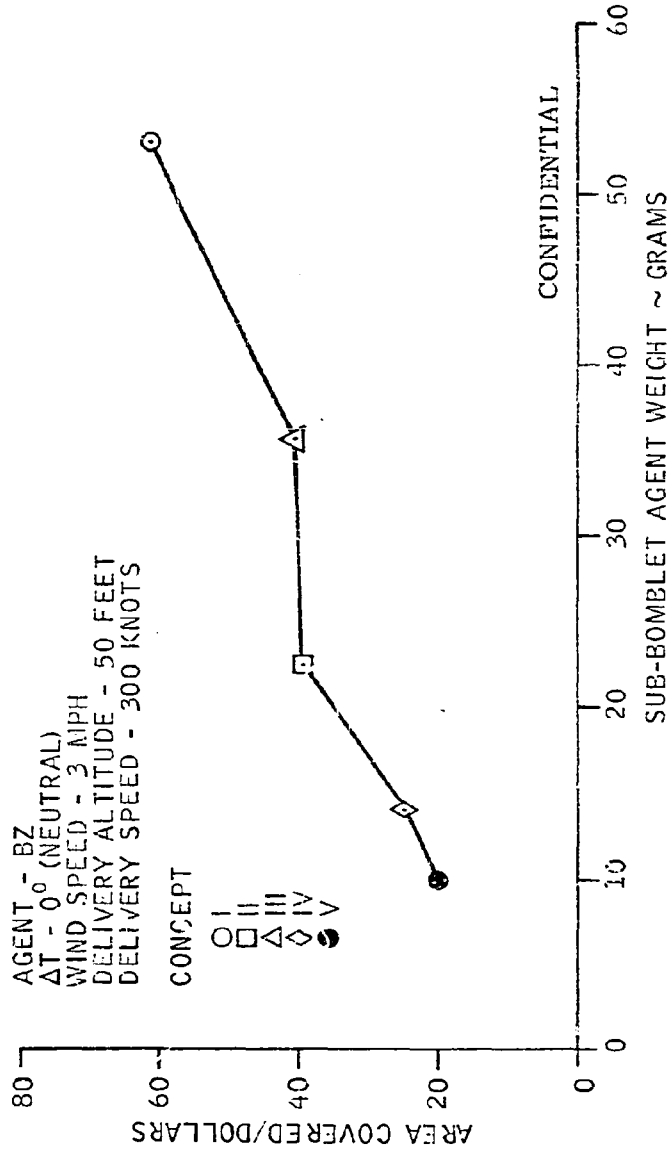

Figure 29. Cost Effectiveness Comparison at 30% Casualties, Agent BZ (50-foot Delivery Altitude at 300 Knots)

CONFIDENTIAL

CONFIDENTIAL

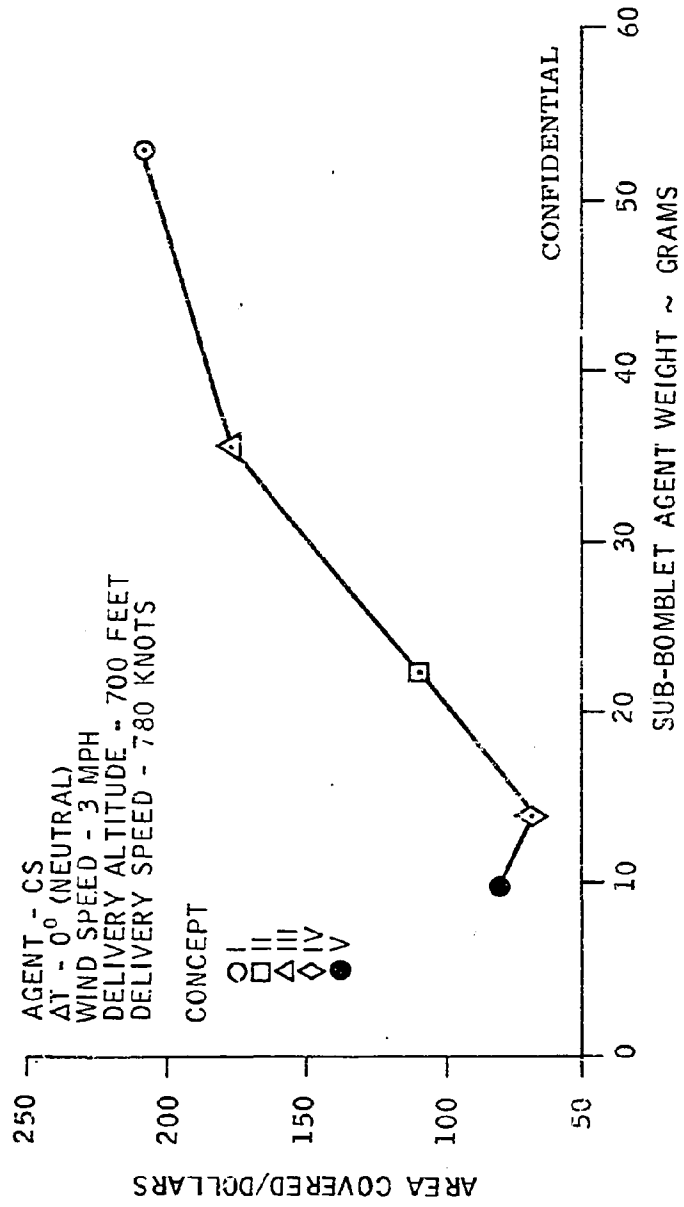

Figure 30. Cost Effectiveness Comparison at 30% Casualties, Agent CS (700-foot Delivery Altitude at 780 Knots)

CONFIDENTIAL

CONFIDENTIAL

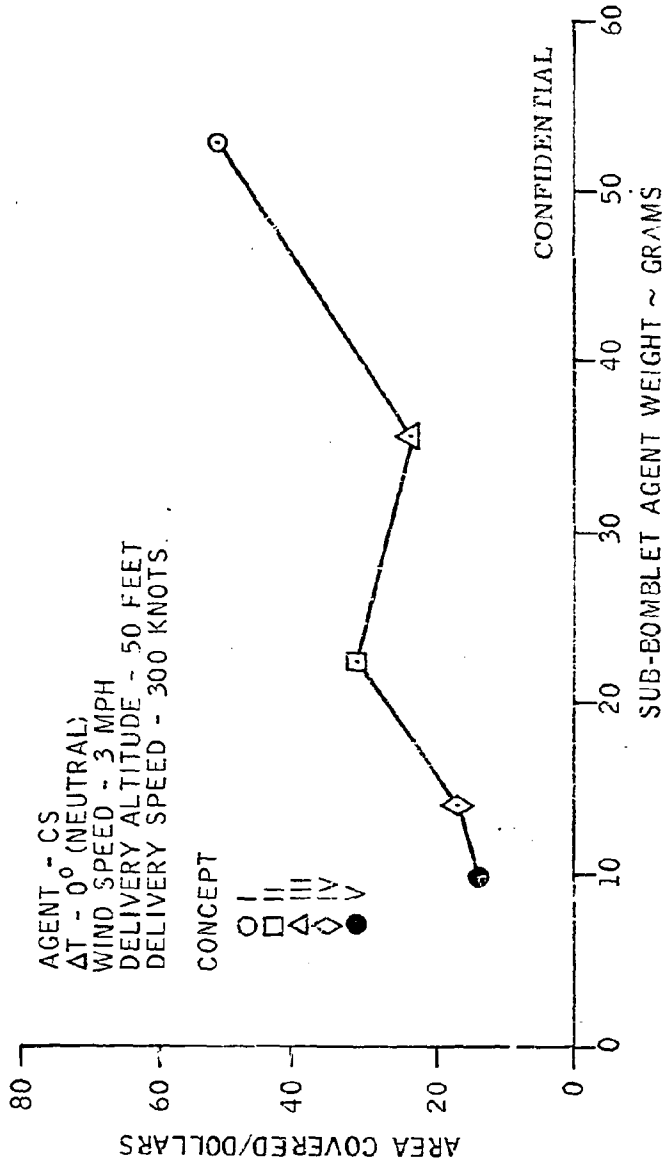

Figure 31. Cost Effectiveness Comparison at 30% Casualties, Agent CS (50-foot Delivery Altitude at 300 Knots)

CONFIDENTIAL

CONFIDENTIAL

were included among the chemical agents recommended by the study for use in the four situations summarized in table I.

(C) (1) Munition Expenditures - The bomblet expenditure requirements for the four tactical situations studied were calculated parametrically as a function of the target size specified for each counterinsurgency situation. The results are presented in figures 32 and 33. It was assumed that the delivery of the agent was 100 percent efficient. A fractional target area coverage of 0.9 and 0.3 at the IC_t50 were assumed. This will cause about 30 and 40 percent casualties, respectively.

(C) (2) Description of Tactical Situations - The four tactical situations are described briefly in the following paragraphs:

(C) (a) Counterambush - In the counterambush role, the bomblet must provide immediate and extensive incapacitation of the attacking force. The onset time of the agent plus the delivery time must be less than 50 seconds, and the duration of incapacitation should be several minutes. Longer lasting incapacitation is of secondary interest in that it provides an opportunity to regroup, withdraw, or pursue the attackers.

(C) The target area is assumed to be 300 by 400 meters with a central island of friendly forces 100 x 100 meters, for a total area of 11×10^4 square meters. Applying the nonhazardous bomb in such a situation would require continuous air cover to fulfill the short delivery time requirement. Also, the close proximity to the enemy of the friendly force would necessitate the use of gas masks.

(C) The most useful agent for this situation is CS because its response time and duration closely match the agent requirements. BZ would be useful as a follow-up agent to aid in succeeding operations against the attackers.

CONFIDENTIAL

TABLE I. SITUATION SUMMARY

OPERATIONAL SITUATION	PARAMETER			TERRAIN AND VEGETATION
	SIZE OF TARGET (M ²)	TIME TO ACHIEVE INCAPACITATION	DURATION OF INCAPACITATION	
1. COUNTER-AMBUŞH	100 X 100 (INNER)	60 SECONDS (INCLUDING DELIVERY); 5 MINUTES NOT USEFUL	EFFECTIVE FOR 1 MINUTE IS ACCEPTABLE. LONGER PERIOD IS PREFERABLE	ALL TYPES, INCLUDING HEAVY VEGETATION
2. LANDING-ZONE PREPARATION	FROM 200 X 200 TO 1000 X 1000	20 MINUTES OR MORE IS ACCEPTABLE	SEVERAL HOURS	OPEN TERRAIN IN LANDING ZONE, BUSHES, TREES, WOOD LOTS, AND HILLS ON PERIMETER
3. SEARCH AND SEIZE	1000 X 1000	MUST BE RELIABLY KNOWN TO PERMIT TIMELY ARRIVAL OF PATROL	SUFFICIENT TO PERMIT ACCESS TO ENTIRE AREA (1/4 - 1 HOUR DEPENDING ON TERRAIN)	ALL TYPES, INCLUDING HEAVY VEGETATION
4. PERIMETER DEFENSE	FROM 30 X 30 TO 1000 X 1000*	TIME TO WALK 100 TO 400 M	SEVERAL MINUTES. LONGER PERIOD HIGHLY DESIRABLE	SURROUNDING OPEN AREA 100 TO 400 M DEEP; VARIOUS TYPES BEYOND OPEN AREA

*NOTE: THE AREA ENCLOSED BY THE DEFINED PERIMETER MAY VARY FROM LESS THAN A HECTARE TO ABOUT A SQUARE KILOMETER. OUTSIDE THE PERIMETER, A SURROUNDING ZONE 200 M TO 400 M IN DEPTH H'S BEEN CLEARED. AGENT APPLICATION WILL PROBABLY BE OVER THIS AREA AND EVEN OVER THE UNCLEAR AREA BEYOND THIS.

CONFIDENTIAL

CONFIDENTIAL

CONFIDENTIAL

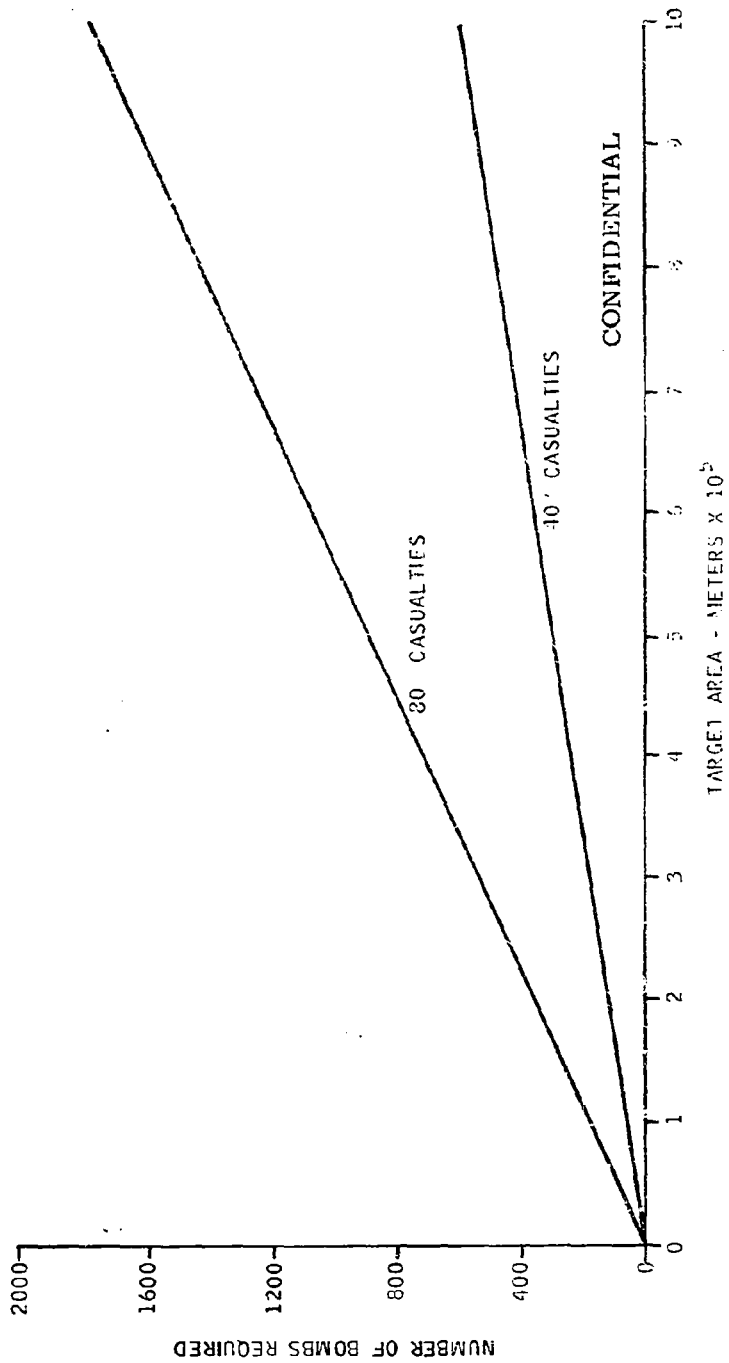
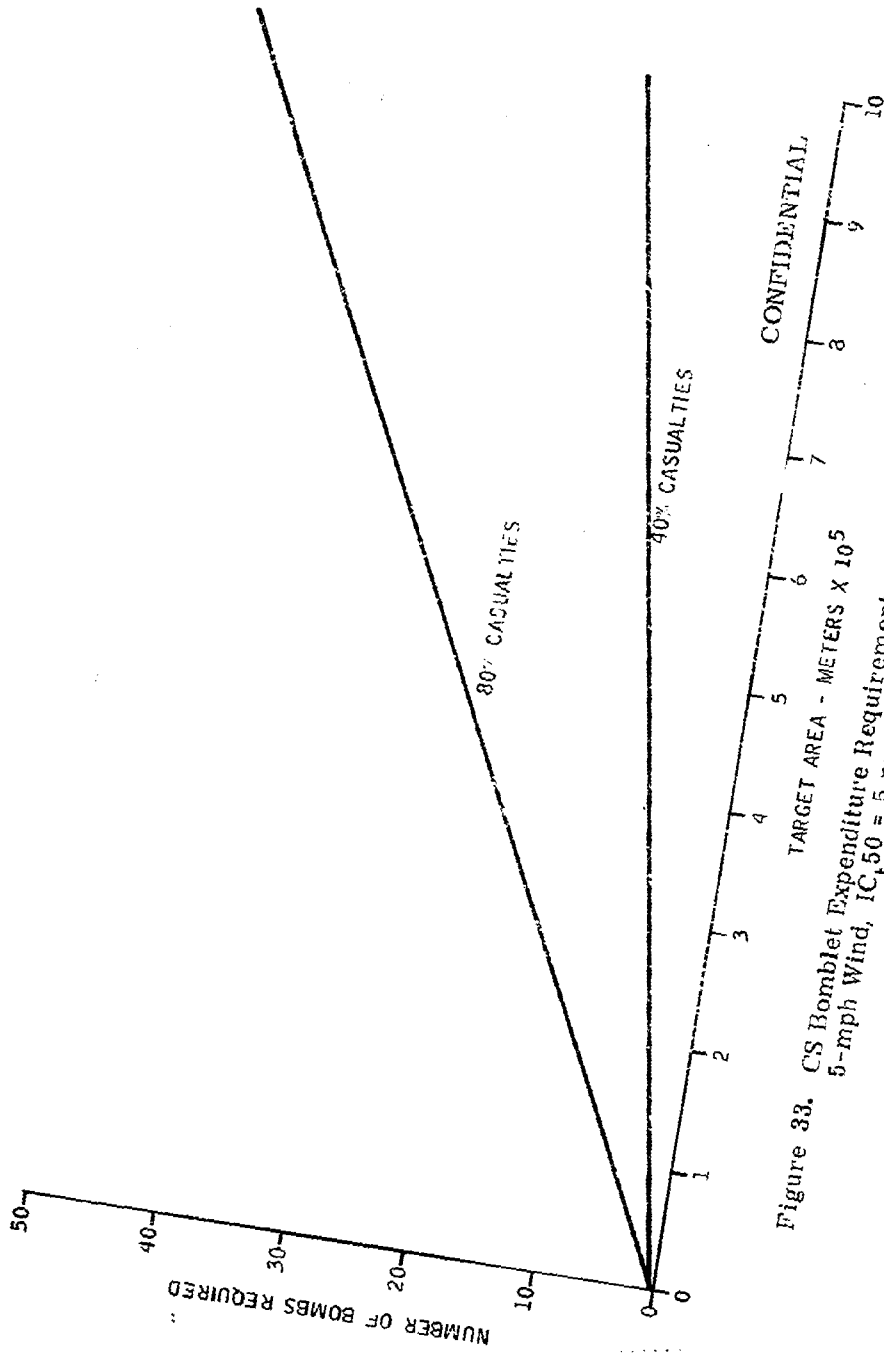

Figure 32. BZ Bomblet Expenditure Requirements - Neutral Atmosphere,
5-mph Wind, $IC_{t50} = 112 \text{ mg-min/m}^3$

CONFIDENTIAL

CONFIDENTIAL



CONFIDENTIAL

Figure 33. CS Bomblet Expenditure Requirements - Neutral Atmosphere,
5-mph Wind, $IC_{t50} = 5 \text{ mg-min/m}$

-56-
CONFIDENTIAL

CONFIDENTIAL

(C) The target area could be covered in two different ways. One large pattern could be used to cover the entire area, including that occupied by the friendly forces. This would provide the most rapid coverage, but would increase the possibility of incapacitating the friendly force. Alternately, successive passes around the perimeter of the friendly force could be made to cover only the area containing the attacking forces. This procedure minimizes the chance of incapacitating friendly personnel, but it would take longer. Either of these pattern sizes could be produced by varying the delivery speed or altitude, as shown by the data in figures 34 and 35. The latter case was used for determining bomb expenditure requirements for this situation.

(C) (b) Landing zone preparation - The mission of the bomblet in this situation is to suppress enemy fire into the landing zone and the helicopter approach and departure routes. The landing operation takes place over a period of about two hours. Coverage would be required either continuously or coordinated precisely with each wave of incoming helicopters. The onset time of the incapacitors need not be short, but it must be predictable. The target area varies from 200 x 200 meters to 1000 x 1000 meters. For this study, it was assumed to be 500 x 500 meters (25×10^4 square meters).

(C) If CS is to be used in the nonhazardous bomblet, it would have to be reapplied every 5 minutes to provide coverage during the entire landing operation. The 24-hour or more duration of BZ incapacitation more than fulfills the landing operation requirements. Also, its 1-hour onset time is appropriate for this situation. The expenditure requirements were calculated for only one application of CS. Additional applications would simply multiply the amount of agent needed, assuming no persistence of the agent.

CONFIDENTIAL

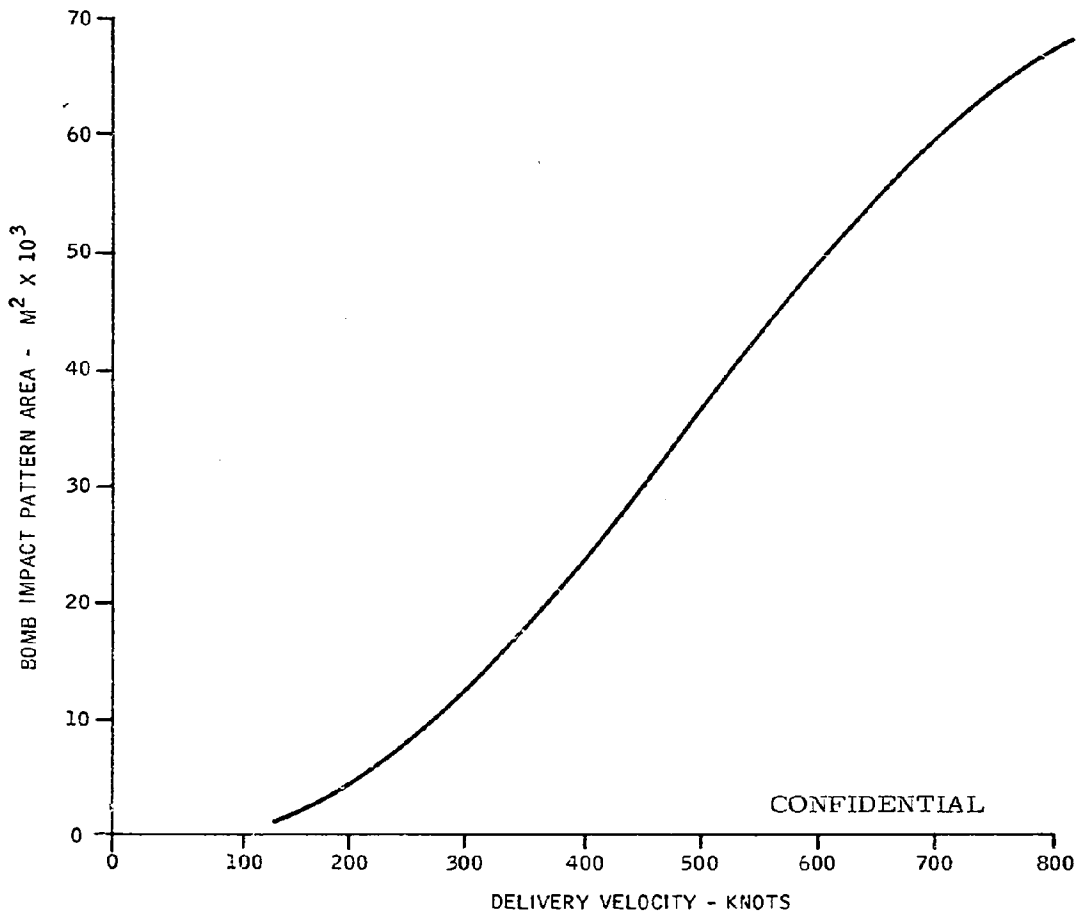

Figure 34. Ninety-five Percent Sub-bomblet Impact Pattern Size, 50-foot Altitude

CONFIDENTIAL

CONFIDENTIAL

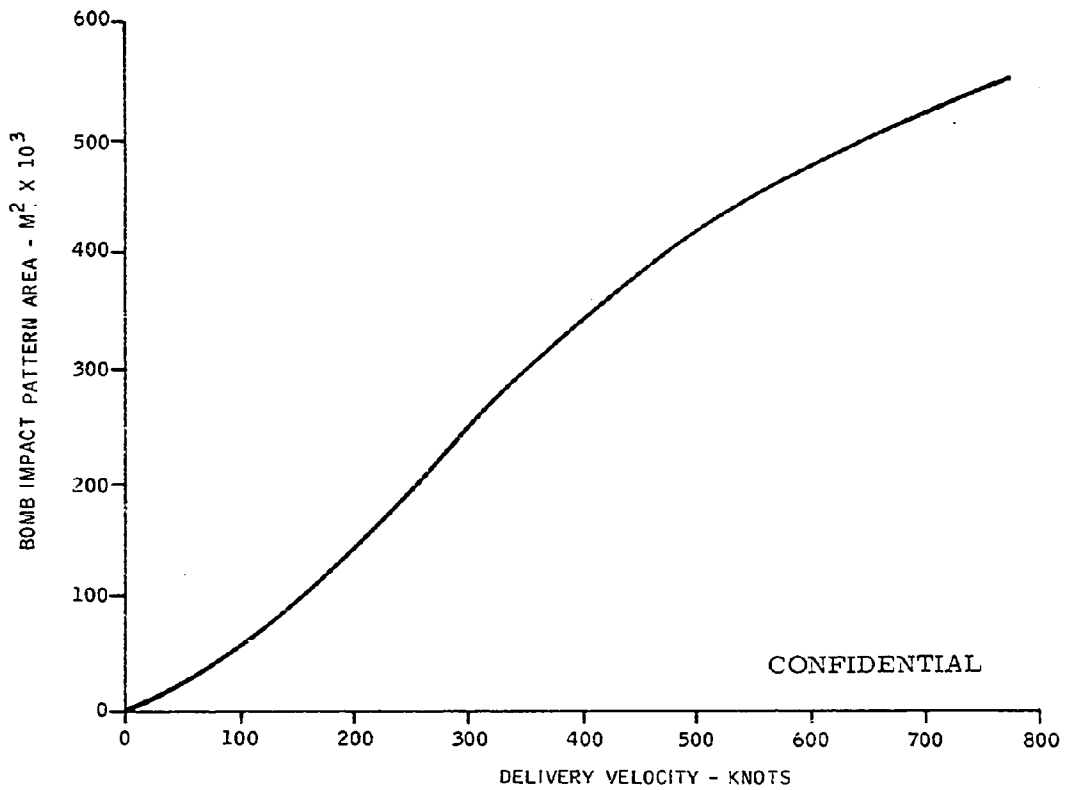

Figure 35. Ninety-five Percent Sub-bomblet Impact Pattern Size, 300-foot Altitude

CONFIDENTIAL

CONFIDENTIAL

(C) (c) Search and seize - In this situation, an enemy force is suspected to occupy an area. The weapon must incapacitate the personnel in this area so that it may be safely searched and the enemy personnel captured.

(C) The onset time of the agent should be short enough to prevent the enemy from fleeing the area (in the order of 30 to 60 minutes). The duration of incapacitation required will vary depending on the time required to search the area. The area of the target was taken to be 1 square kilometer.

(C) BZ would be the more useful of the two agents because of its long duration of incapacitation. Its relatively long onset time might require the use of a second agent such as CS to prevent escape of the enemy. CS could also be used against areas of resistance encountered during the search operation.

(C) (d) Perimeter defense - The objective of the weapon in this situation is to prevent an enemy from crossing a perimeter set up about some friendly position and overcoming the position. The perimeter is assumed to be 200 meters deep, surrounding an area 500 meters square (56×10^4 square meters).

(C) An attack is usually of 15 to 20 minutes duration, but may be as long as an hour. This would require a relatively fast reaction time and agent response time. The duration of incapacitation should be as long as the duration of the battle, or repeated applications of agent should be made.

(C) An air strike with the nonhazardous bomblet would be of limited value in such a situation because the attacks are of such short duration that there may not be time to launch the strike. Also, the attacks often take place in poor flying weather and at night. The choice of an agent is obviously CS because of the short onset time required. BZ would be used only in a secondary role for counterattacks against the enemy force.

CONFIDENTIAL

(C) (3) Calculation of Optimum Delivery Altitudes - The optimum delivery altitudes⁵ (those resulting in maximum area coverage) were calculated for various aircraft delivery velocities. The calculations were based on the results of the data obtained from the studies of bomblet area cover and theoretical effectiveness. The optimum delivery conditions for both CS- and BZ-loaded bomblets are summarized in table II. The data in table II show that, per bomblet sortie, the delivery velocities for both CS- and BZ-loaded bomblets are theoretically quite low. For greater delivery velocities, therefore, more than one sortie should be made over the target area to make up for the larger than optimum sub-bomblet impact patterns. The exact number of passes to be made will depend on the altitude and desired delivery velocity. These data can be estimated by using the data in the pattern-versus-velocity charts in figures 34 and 35.

3. Fuzing

(U) The designs for the cluster fuzing and the sub-bomblet fuzing are discussed in the following paragraphs.

(U) a. Cluster Fuzing - The primary fuzing system used in the non-hazardous cluster bomblet is a modified BLU-4 timer combined with a pyrocore column and an explosive bolt. This selection was based on the success of this system in an earlier nonhazardous cluster bomblet design.

(U) The design details and operation of the cluster fuzing system are described in section IV.

⁵Optimum delivery altitude is that altitude at which maximum area coverage is achieved and above which the pattern size becomes so large that the coverage effects are diminished.

CONFIDENTIAL

TABLE II. OPTIMUM DELIVERY CONDITIONS FOR THE
NONHAZARDOUS BOMBLET (30% CASUALTIES OR GREATER FOR BOMBI, ET)

AGENT	DELIVERY ALTITUDE FT	DELIVERY VELOCITY KTS	IMPACT PATTERN M ² X 10 ³	AREA COVERAGE** MAXIMUM M ² X 10 ³
CS	50	270	10.2	21
	300	<50	10.2	21
BZ	50	150	2.5	5.9
	300	<50	2.5	5.9

** NEUTRAL ATMOSPHERE - 3 MPH WIND

CONFIDENTIAL

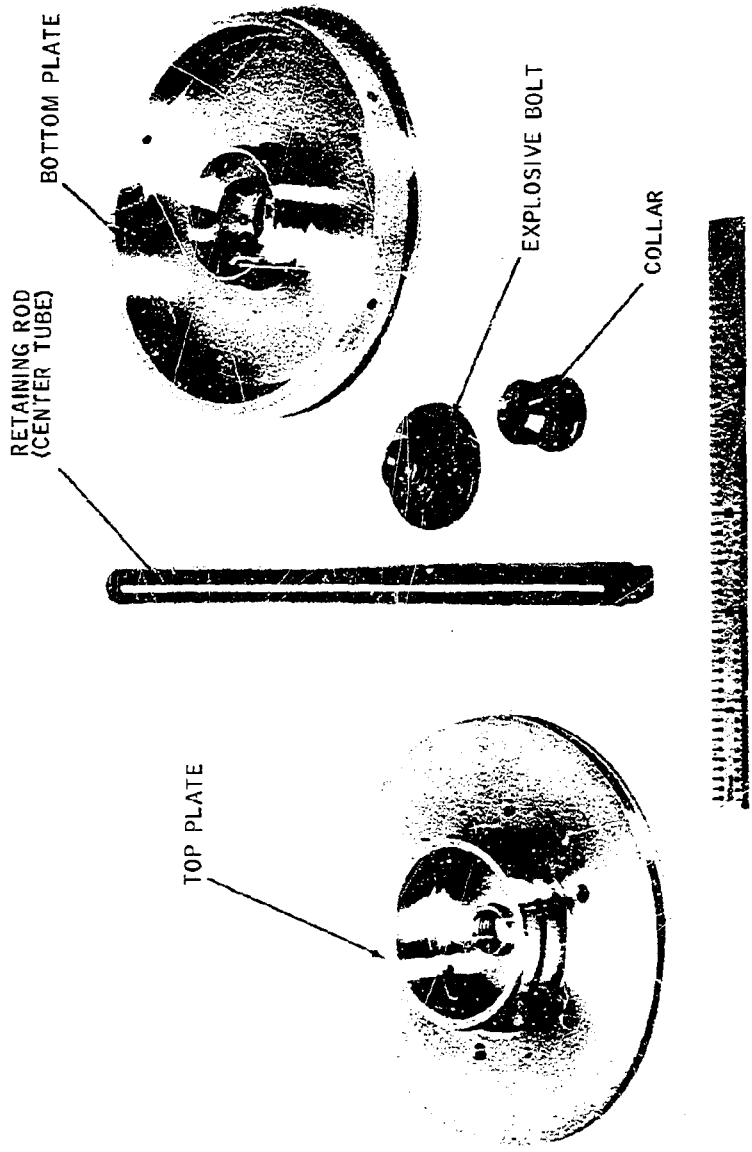

UNCLASSIFIED

Figure 36. Disassembled Cluster (No Sub-bomblets)



UNCLASSIFIED

Figure 37. Assembled Cluster (No Sub-bomblets)

(U) b. Sub-bomblet Fuzing - A slightly modified version of the FMU-65/B mechanical, omni-directional, impact-initiated fuze was selected for use in the nonhazardous sub-bomblets because this fuze --

- Provides for design simplification of cluster hardware,
- Offers the flexibility of high-altitude delivery,
- Provides for sub-bomblet function immediately upon ground impact, thus minimizing troop response time,
- Eliminates requirement for sub-bomblet flotation device,
- Provides adaptability to various means of agent dissemination, and
- Is amenable to economical methods of high production.

(U) The design details and the operation of the FMU-65/B fuze in the non-hazardous bomblet are described in section IV.

4. Preliminary Hardware Evaluation

(U) Prior to specifying the detailed cluster design for MIL-STD and flight test evaluation, various studies and tests were conducted to evaluate specific hardware components. The following hardware areas were checked:

- Bomblet structural integrity
- Parachute packaging
- Sub-bomblet material
- Sub-bomblet interlocks
- Explosive bolt attachment
- Flotation device

Each of these areas is discussed in the following paragraphs:

(U) a. Bomblet Structural Integrity - An aerodynamic study provided data on the structural loads imposed on the bomblet by the deployment of the parachute. Since parachute deployment imposes the most severe structural loads on the bomblet, data were used to establish the critical structural loads which the bomblet would have to withstand in order to perform reliably. The theoretical maximum structural loads established for the bomblet (see table III) were based on the most severe aerodynamic condition (a Mach 0.9 delivery at an altitude of 50 feet). The structural design goals listed in table III were established by applying a 50% safety factor to the theoretical design loads.

(U) To determine the structural strength of the bomblet cluster a closely monitored axial tensile load was applied to the various bomblet joints. The tests indicated the design goals for the top plate/center tube attachment, center tube, center tube/bottom plate attachment, and explosive bolt-function loads were satisfied. The typical cluster hardware tested is shown in figures 36 and 37. The results of these tests and their comparison with the respective design goals are summarized in table IV.

(U) As indicated in table IV all of the tests conducted, except the first two explosive bolt units, satisfied the design goal. The first two explosive bolt units failed structurally as diagrammed in figure 38. When subjected to axial tension loads exceeding 2000 lbs the necked section sheared through the bottom flange. To prevent this shearing, the flange section was increased in thickness by 0.050 and designed as shown in figure 39. Upon subsequent testing of the revised bolt it was found the bolt did not fail until tension loads exceeding 5000 lbs were applied (see table IV, tests 3 and 4). This revision was incorporated in the explosive bolt design.

(U) In addition to the above controlled load tests, a 40-foot drop test was conducted with a bomblet comprised of a cluster assembly and dummy plastic sub-bomblets to evaluate its impact shock load integrity. The test bomblet was dropped from 40 feet onto a steel plate. The condition of the test

TABLE III. SUMMARY OF THEORETICAL STRUCTURAL LOADS AND DESIGN GOALS

FORCE SOURCE AND APPLICATION	THEORETICAL VALUE	FORCE DIRECTION	DESIGN GOAL
PARACHUTE SNATCH LOAD			
SHROUD LINES	3300 LBS	OBLIQUE TENSION	4950 LBS
PARACHUTE OPENING LOAD			
SHROUD LINES	2600 LBS	AXIAL TENSION	3900 LBS
PARACHUTE RING/TOP PLATE ATTACHMENT	2600 LBS	AXIAL TENSION	3900 LBS
TOP PLATE/CENTER TUBE ATTACHMENT	2600 LBS	AXIAL TENSION	3165 LBS
CENTER TUBE	2100 LBS	AXIAL TENSION	3165 LBS
CENTER TUBE/BOTTOM PLATE ATTACHMENT	1950 LBS	AXIAL TENSION	2800 LBS
EIGHT SUB-BOMBLET LINER	435	AXIAL COMPRESSION	650 LBS
BOMBLET DECELERATION			
SHROUD LINES	1630 LBS	AXIAL TENSION	2445 LBS
PARACHUTE RING/TOP PLATE ATTACHMENT	1630 LBS	AXIAL TENSION	2445 LBS
TOP PLATE/CENTER TUBE ATTACHMENT	1630 LBS	AXIAL TENSION	2445 LBS
CENTER TUBE	1330 LBS	AXIAL TENSION	1950 LBS
CENTER TUBE/BOTTOM PLATE ATTACHMENT	1180 LBS	AXIAL TENSION	1770 LBS
EIGHT SUB-BOMBLET LINER	265 LBS	AXIAL COMPRESSION	395 LBS
BOMBLET EVENT			
EXPLOSIVE BOLT FUNCTION	UNDETERMINED	----	SATISFY STATIC TEST LOADS
		UNCLASSIFIED	

TABLE IV. STRUCTURAL STRENGTH TESTS

FORCE APPLICATION (OPENING-LOAD CONDITION)	DESIGN GOAL	FORCE DIRECTION	TEST RESULTS			
			TEST 1	TEST 2	TEST 3	TEST 4
PARACHUTE RING/TOP PLATE ATTACHMENT	3900 LBS	AXIAL TENSION	TNC*	TNC	TNC	TNC
TOP PLATE-CENTER TUBE ATTACHMENT	3165 LBS	AXIAL TENSION	10,040	>10,000†	----	----
CENTER TUBE	3165 LBS	AXIAL TENSION	>10,000†	>10,000†	----	----
CENTER TUBE/BOTTOM PLATE ATTACHMENT	2800 LBS	AXIAL TENSION				
COLLAR/TUBE THREADS			4,340	TNC	----	----
COLLAR/EXPLOSIVE BOLT THREADS			>5,000	>5,000	----	----
EXPLOSIVE BOLT			2,080	2,160	5,340 ^{10A}	5,000†
EIGHTH SUB-BOMBLET LAYER	650 LBS	AXIAL COMPRESSION	TNC	TNC	TNC	TNC
UNCLASSIFIED						
* TNC = TEST NOT COMPLETED † DESIGN REVISION INCORPORATED						

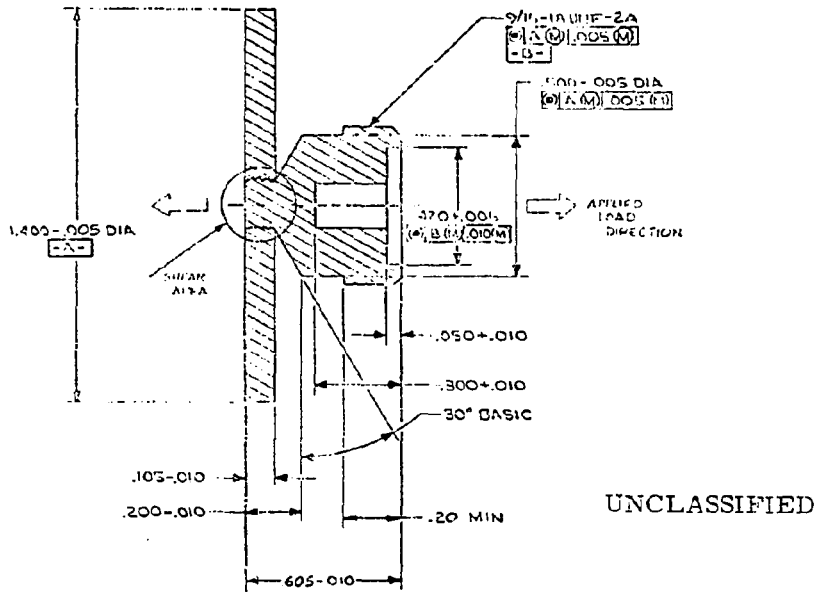

UNCLASSIFIED

Figure 38. Explosive Bolt Structure Failure

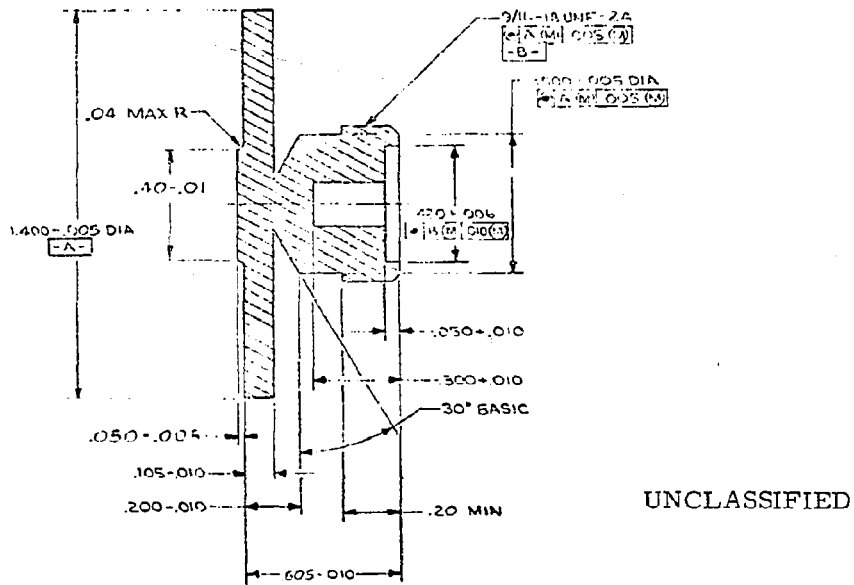

UNCLASSIFIED

Figure 39. Revised Explosive Bolt

bomblet after the drop test is shown in figure 40. Other than a slight bend of the center tube and the loss of one sub-bomblet (the solid plastic cracked), the test bomblet remained intact and structurally sound.

(U) b. Parachute Packaging - The preliminary parachute package utilized a Fiber Frax and asbestos covering in conjunction with a metal and plastic cup. The parachute was deployed by a static line and a 30- to 50-pound break link affixed to the SUU-13/A dispenser tube.

(U) This improved and simplified parachute package was based on the design developed for the BLU-20/B23 bomblet. The package is simplified by the use of just a plastic cup and cover. The cover has an integral metal plate which shields the cover from the hot ejection gases. The cup packages the parachute and protects it from the ejection environment.

(U) Another improvement is the elimination of the static line for parachute deployment. This package utilizes the drogue effect of the parachute cover, to deploy the parachute.

(U) c. Sub-bomblet Material - A comprehensive trade-off study was conducted to determine which plastic material would be used for sub-bomblet construction. The structural, assembly, and cost characteristics of the candidate materials were determined and rated according to their applicability to the nonhazardous bomblet. The results of this study are summarized in tables V and VI.

(U) The material selected for sub-bomblet construction was ABS Cycolac, type X-27. The results of this study were reviewed with Edgewood Arsenal personnel who have done extensive work with the loading and testing of similar plastic munitions, and they concurred with the selection.

(U) d. Sub-bomblet Interlocks - Another design area studied was the interlocking scheme for the sub-bomblets. Pins were originally used to hold the sub-bomblets together in the cluster. These however were



UNCLASSIFIED



Figure 40. Test Bomblet after 40-foot Drop

TABLE V. CANDIDATE SUB-BOMBLET MATERIALS, DESIGN CHARACTERISTICS

CHARACTERISTICS	40% GLASS FILLED NYLON	30% GLASS FILLED NYLON	PLASKON 8202 TYPE 6	ABS CYCOLAC X-27	HI-DENSITY POLYETHYLENE TYPE II
TENSILE STRENGTH PSI	30,000	21,000	10,000	7,300	2,500
ELONGATION	2.1	2.0	300	5.0	100
FLEXURAL STRENGTH 10 ⁵ PSI	35,000	26,000	5,800	11,800	--
IMPACT STRENGTH (IZOD NOTCHED) FT. LB/IN	4.0	3.0	3.0	3.1	--
HEAT DISTORTION TEMPERATURE °F AT 66 PSI	--	--	--	--	--
HEAT DISTORTION TEMPERATURE °F AT 264 PSI	428	425	365	226	150
COMPATABILITY WITH PYROTECHNIC COMPOSITIONS	98%	98%	98%	95%	95%
BONDABILITY	GOOD	GOOD	EXCELLENT	EXCELLENT	POOR
BEST METHOD FOR LIMITED PROTECTION*	LIQUID PHENOL	LIQUID PHENOL	LIQUID PHENOL	WAX	NOT RECOMMENDED
SPECIFIC GRAVITY ¹	1.46	1.37	1.13	1.06	0.950
COST PER POUND (IN 20,000-LB. LOTS) (DOLLARS)	1.60	1.40	0.875	0.46	0.20
COST PER CUBIC INCH (DOLLARS)	8.8	6.9	3.6	1.9	0.7
MOLDABILITY OR PROCESSING COST RATING	FAIR	FAIR	EXCELLENT	GOOD	GOOD
UNCLASSIFIED					
1. SPECIFIC GRAVITY OF 1.0 OR LESS IS DESIRABLE IN TERMS OF FLOTATION CAPABILITY.					
*IN HIGH VOLUME PRODUCTION ALL ABOVE MATERIALS CAN BE INEXPENSIVELY AND RELIABLY JOINED WITH ULTRASONIC WELDING.					

CONFIDENTIAL

TABLE VI. RATING OF CANDIDATE SUB-BOMBLET MATERIAL BY ATTRIBUTE

CHARACTERISTICS	RATING*				
	40% GLASS FILLED NYLON	30% GLASS FILLED NYLON	PLASKON 8202 TYPE 6	ABS CYCOLAC X-27	HI-DENSITY POLYETHYLENE TYPE II
TENSILE STRENGTH	5	4	3	2	1
ELONGATION	3	3	0	2	1
FLEXURAL STRENGTH	3	2	1	2	1
IMPACT STRENGTH (IZOD NOTCHED)	7	6	5	5	1
HEAT DISTORTION TEMPERATURE	3	3	2	(1)	1
COMPATIBILITY WITH PYROTECHNIC COMPOSITIONS	6	6	6	6	3
BONDABILITY	4	4	6	6	0
SPECIFIC GRAVITY	1	2	3	4	5
COST	3	3	6	9	10
MOLDABILITY OR PROCESSING	4	4	9	8	8
TOTAL	39	37	41	46	31
ORDER OF SELECTION	3	4	2	1	5

* 10 POINT RATING SYSTEM WITH NUMBER OF POINTS GIVEN COMPARATIVE FOR EACH CHARACTERISTIC AND BASED ON IMPORTANCE OF CHARACTERISTICS TO TOTAL SYSTEM EFFECTIVENESS AND COST.

(1) CYCOLAC DESIRABLE IN THAT ITEM IS NON-RECOVERABLE AFTER FUNCTION; I.E., HEAT GENERATED BY THERMAL GENERATION DESTROYS ITEM AND NO IDENTIFYING DESIGN FEATURES ARE AVAILABLE TO ENEMY.

CONFIDENTIAL

CONFIDENTIAL

CONFIDENTIAL

unacceptable in that they were costly and did not reliably separate upon cluster release.

(U) The design approach selected involved molding the top and bottom halves of the sub-bomblet to the shapes shown in figure 41. The advantage of this design is that it affords maximum usage of the sub-bomblet volume for the agent and is amenable to high volume production.

(U) e. Explosive Bolt Design - The designs for the bottom plate and explosive bolt are shown in figure 42. The bottom plate is crimped over the flange of the explosive bolt upon cluster assembly. The crimping method is very adaptable to mass production methods. The crimping is illustrated in figure 43, which also shows a test slug typical of those used to determine the crimp strength described earlier.

(U) To check the assembly tolerancing and the functioning of the cluster ignition train (pyrocore) and explosive bolt, three bomblets were assembled. These units consisted of a top plate, center tube, pyrocore column, collar, explosive bolt, explosive bolt elements, and bottom plate. The assembly tolerancing was found to be satisfactory. To check the ignition train and explosive bolt, the pyrocore was ignited by a small RDX charge that was located at the top end of the pyrocore column to simulate the output of the BLU-4 timer. The tests indicated that venting was necessary to prevent the crimp from damage by the explosive bolt detonation. After a vent hole was added through the bolt flange, all elements performed satisfactorily.

(U) f. Flotation Device - A chimney type flotation device consisting of an integral conical spring and a flexible mylar sack was considered for use with the nonhazardous sub-bomblet. With the incorporation of the impact-initiated FMU-65/B fuze, the requirement for a flotation device no longer existed, and further studies were dropped.

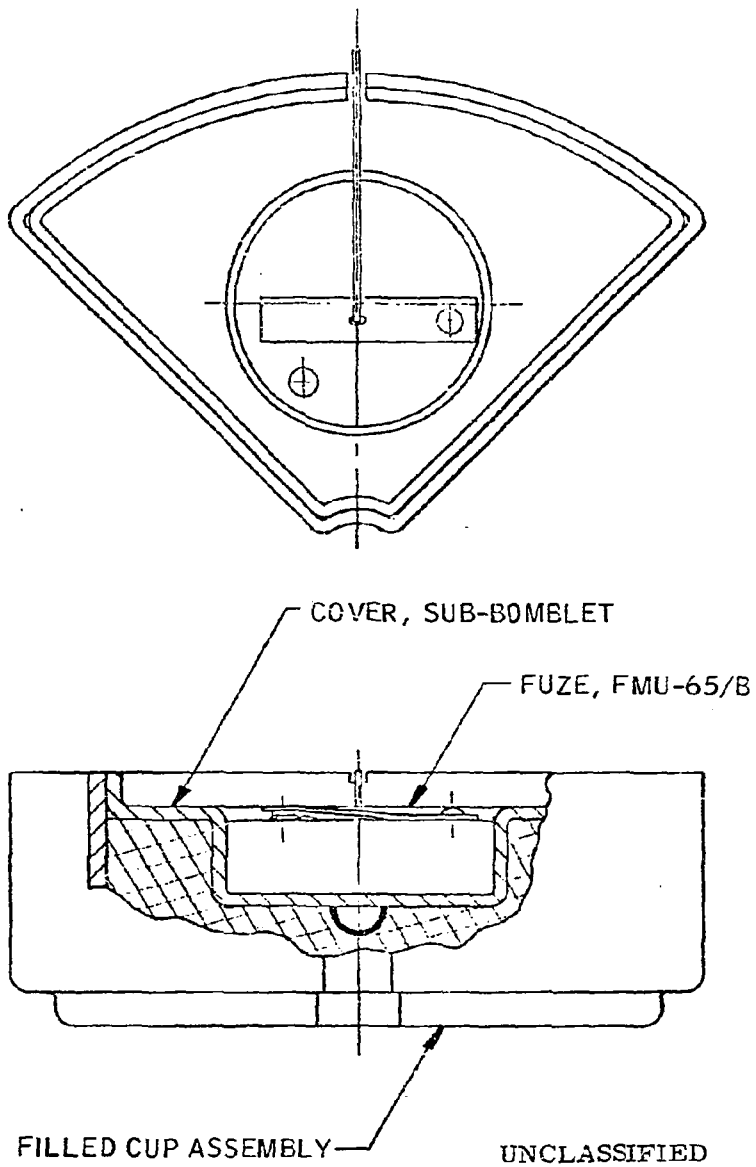

Figure 41. Sub-bomblet Configuration

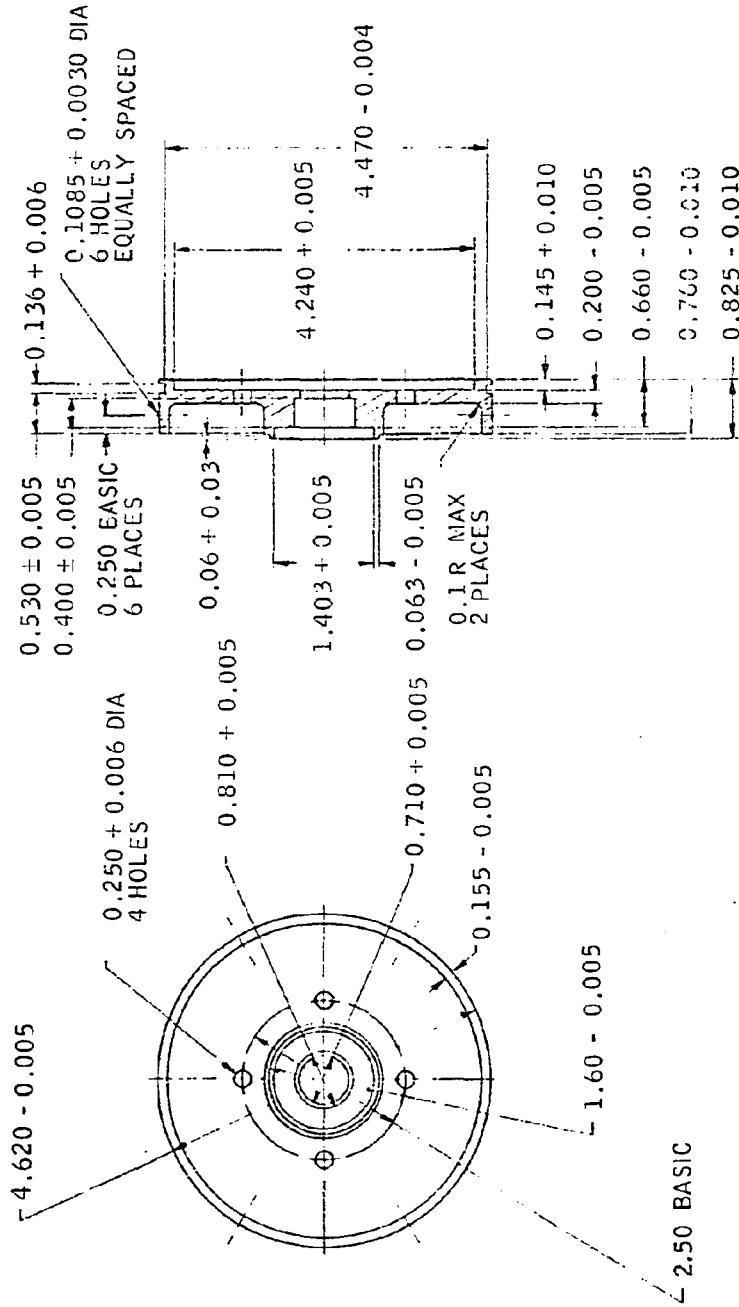
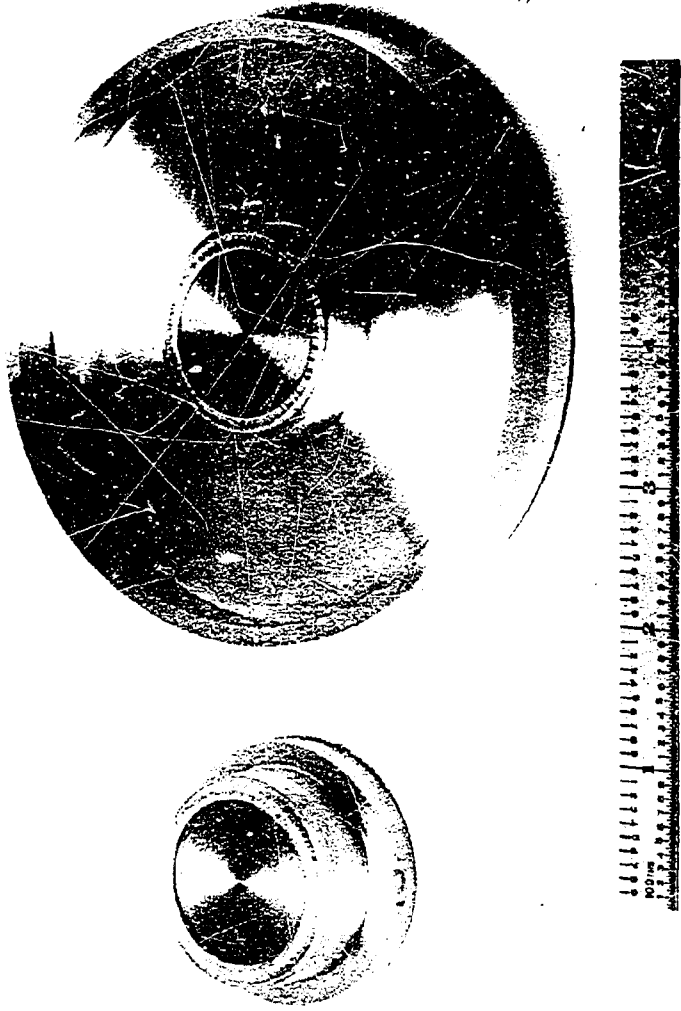

Figure 42. Bottom Plate

UNCLASSIFIED



UNCLASSIFIED

Figure 43. Bottom Plate and Explosive Bolt Crimp Test Hardware

B. PREPROTOTYPE, MIL-STD, AND FLIGHT TEST EVALUATION

(U) Upon selecting the preprototype bomblet design, a series of functional, MIL-STD, and flight demonstration tests were conducted. The specific test categories were as follows:

- Sub-bomblet refinement tests
- MIL-STD and preflight demonstration tests
- Flight testing

1. Sub-Bomblet Refinement Testing

(U) Initial static function tests of sub-bomblets loaded with pyrotechnic red smoke indicated that there was insufficient venting to allow proper ignition and smoke cloud generation. Also, the recommended Chem Corps starter mixture proved inadequate.

(U) In initial tests of 33 sub-bomblets, those loaded with a dry pressed starter mixture broke apart upon fuze function. Case fractures upon fuze function also occurred in an initial group of sub-bomblets tested with a liquid form of the Chem Corps B143-7 starter mixture which was slurried into the starter core. The extent of fracturing, typical of these tests, is illustrated in figure 44.

(U) In an attempt to prevent fracturing the 0.187-inch diameter vent holes in each end of the sub-bomblet were enlarged, and a vent hole was added in the fuze cover. Also, a new test fixture was designed to replace the old fixtures, which confined the sub-bomblet sides so all the fuze output pressure was exerted on the radiused side. The new static test fixture, which permitted a more realistic flexure of the sub-bomblet walls, is shown in figure 45.



UNCLASSIFIED

Figure 44. Malfunctioned Sub-bomblet

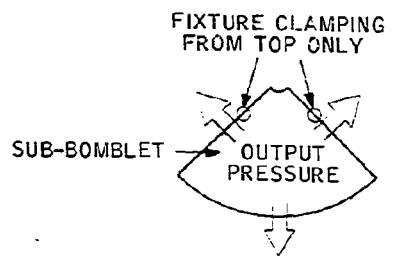

UNCLASSIFIED

Figure 45. Redesigned Sub-bomblet Static Test Fixture

(U) The use of the new fixture, along with varying the vent hole sizes and increasing the free (void) volume directly beyond the fuze output hole, prevented sub-bomblet breakup in subsequent tests. An improved method of ignition was sought, however, since only 50% of a subsequent group of sub-bomblets ignited properly with the Chem Corps B143-7-3 starter mixture. Quickmatch had been recommended by Edgewood Arsenal as a more sensitive starter that could easily replace the Chem Corps starter in this sub-bomblet. An 1.875-inch length of Quickmatch (type 1 class A per MIL-Q-373) was then tested.

(U) With Quickmatch as a starter, a total of 17 sub-bomblets were functioned. Each ignited perfectly, generating a dense red smoke cloud for periods ranging from 20 to 45 seconds. A sub-bomblet function typical of this group is shown in figure 46.

(U) b. Temperature and Shock Tests - After reliable static functioning had been established, tests were conducted to determine the effects of temperature and physical shocks on sub-bomblet functioning. A group of four sub-bomblets were submitted to temperature shock tests per MIL-STD-810A, method 503. Two bomblets that were functioned statically generated red smoke for approximately 30 seconds. Another sub-bomblet duded when dropped 20 feet onto firm ground.

(U) Concurrently, ten smoke-loaded sub-bomblets with FMU-65/B fuzes were drop tested. These fuzes were the results of a recent fuze revision made to eliminate occasional duds. Approximately 15 percent of the first group of sub-bomblets that were shock tested duded upon ground impact. The cause was improper impingement of the detonator on the fuze firing pin, which was corrected by removing an inherent burr flash within the detonator slide slot in the cast fuze housing.

(U) The results of drop tests of a final group of ten sub-bomblets loaded with smoke and FMU-65/B fuzes indicated that the impingement problem had been corrected.



Figure 46. Typical Sub-bomblet Function

CONFIDENTIAL

(U) c. Dissemination Tests - A detailed report of the test series is given in Appendix C. A summary of CS and BZ agent dissemination efficiency tests is presented in the following paragraphs. These tests were completed at the aerosol recovery chamber operated by the Illinois Institute of Technology Research Institute (IITRI) in Chicago, Illinois.

(C) (1) CS Dissemination Tests - The results of the CS dissemination tests are summarized in table VII. In all, ten sub-bomblets were tested. The dissemination efficiencies for the final sub-bomblet design ranged from 50 to 76 percent, the higher efficiencies being obtained as the CS loading operation improved.

(U) (2) BZ Dissemination Tests - The BZ dissemination tests were conducted in two phases: loading at Edgewood Arsenal, and testing at IITRI.

(C) (a) Loading - The loading of 10 sub-bomblets with BZ was accomplished with the tools illustrated in figure 47. The following conclusions resulted from consultations with Edgewood Arsenal:

- The previously specified Chem Corps B143-14-6 mixture cannot be used in any BZ munition because of a recent Government edict that the mixture is unsafe for loading.
- A new mixture called "Hooker 283" was used in the sub-bomblets. This new mixture contains a higher percentage of BZ than the former (55% compared to 50%) and is loaded in a "wet" instead of "dry" condition, as was the former BZ mix. The CS and smoke mixes currently used are loaded "dry".
- The so-called "wet" loading would normally create a problem with the current sub-bomblet because a binder containing approximately 5 percent acetone is used. Acetone is incompatible with Cycloac X-27 from which the sub-bomblet is made. To circumvent this problem with the ten sub-bomblets on hand, the "wet" binder solution was not used and the BZ mixture was press loaded "dry". As mentioned above, this is not the standard loading procedure for this mix and thus cannot be used in future loading operations.

CONFIDENTIAL

TABLE VII. SUB-BOMBLET DISSEMINATION TEST SUMMARY

TEST UNIT NUMBER	CS PYROTECHNIC MIX FILL DENSITY - GRAINS/CM ³ COMP. 11133-13-7	CS PYROTECHNIC CONSTRUCTION LOAD - LBS	SUBMUNITION FUNCTION TIME-SEC.	DISSEMINATION EFFICIENCY - PERCENTAGE AT 10'	INFLATABLES ATRODOL AT 10' (1)	INFLATABLES ATRODOL AT 30' (2)	AMTD OF AEROSOL - "	REMARKS
1	30	9000	20-25	99.0 ³	3670	2675	1.72	CRUDE FILL, QUITE POROUS AND FRAGILE. DEFINITE IMPROVEMENT DESIRED IN FILLING DENSITY AND STRENGTH. SUBMUNITION IGNITION AND FUNCTION WAS GOOD. FILL COMPLETELY DISSEMINATED WITHOUT FLAMING.
2								NO TEST UNIT. EARLY VERSION OF FMU-05 B FUZE WAS USED, AND IT MALFUNCTIONED. AT THIS POINT IN TIME (IN 20 7/7), ALL SUBMUNITION TEST FUZES WERE REPLACED WITH LATEST FMU-05 B VERSION.
3	34	5500	13	60.0 ³	4130	3290	1.97	WELL-FORMED FILL AND REASONABLY STRONG. FILL STILL POROUS. HOWEVER, WITH DENSITY OF 1.0, ADDITIONAL FILL PER UNIT DESIRED. SUBMUNITION IGNITION AND FUNCTION WAS EXCELLENT. AGENT CLOUD GENERATED VIGOROUSLY OVER 13 SECOND SPAN. NO FLAMING OCCURRED.
4	35	8900	15	47.2 ³	DF	DF	1.50	WELL-FORMED FILL AND ADDITIONAL GRAM OF MIX PROVIDED. HOWEVER, SUBMUNITION TOP DID NOT FIT FLUSH, INDICATING TOO GREAT A FILL HEIGHT. THE PRESS LOAD WAS INCREASED FROM 5600 LBS. TO 8700 LBS. HOWEVER, THE DENSITY INCREASE ACCOUNTED TO ONLY 6 PERCENT. UNIT IGNITION AND FUNCTION WAS AGAIN EXCELLENT.
5	36	8900	15	50.0 ³	DF	DF	1.60	ADDITIONAL AGENT PYROTECHNIC MIX WAS PROVIDED. BY WETTING THE MIX WITH METHYL ALCOHOL, THIS NOT ONLY BROKE DOWN THE BINDER FOR BETTER COMPACTION, BUT RESULTED IN A STRONGER PRESSED FILL. UNIT IGNITION AND FUNCTION WAS EXCELLENT.
6	35	8900	17	51.0 ³	DF	DF	1.50	SAVE AS NO. 5.

CONFIDENTIAL

CONFIDENTIAL

TABLE VII. SUB-BOMBLET DISSEMINATION TEST SUMMARY (Concluded)

TEST UNIT NUMBER	SE PROBLETTING WAX (G) (WIGHT - GRAMS)	SE PROBLETTING WAX CONCENTRATION (G/CC)	SE PROBLETTING WAX LOAD - LBS	SUBSTITUTION FUNCTION TIME - SEC	DISSEMINATION EFFICIENCY (MEASURED AT 1')	WIND VELOCITY (MPH)	WIND DIRECTION (DEG)	REMARKS
7	33		8700	18	65.0	DF	DF	INSTEAD OF USING VETROL ALCOHOL WITH THE GULK WAX, ONLY THE SURFACE OF THE DRY PRESSED WAX WAS WETTED WITH ALCOHOL. THIS IS A MORE EFFICIENT MEANS OF LOADING AND ACCUMULATING ALCOHOL THE WAX REL. SIZES AS THE WETTED SURFACE OF THE WAX. THE DISSEMINATION RESULTS INDICATED THE BEST EFFICIENCY YET OBTAINED.
8	33		8700	19	72.0	DF	DF	SAME AS UNIT 7. THE ONLY CHANGE IN WAXES WAS INCREASED TO 72 PERCENT. IT WAS CONCLUDED THAT THIS PRESS LOADING METHOD WOULD BE USED IN ALL FUTURE DISSEMINATION LOADS FOR THE AIR FORCE.
9	33		8700	25	72.0	DF	DF	SAME AS UNIT 7.
10	33		8700	20	76.0	DF	DF	SAME AS UNIT 7. DISSEMINATION EFFICIENCY WAS INCREASED AS REQUEST TO DML.

CONFIDENTIAL

NOTES:

- (1) ALL GENERATED AIRSOL IS 10+ OR LESS.
- (2) WIND IS MASS MEAN DIRECTION OF AIRSOL PARTICLES MEASURED AT THREE MINUTES AFTER SUBSTITUTION FUNCTION.
- (3) THESE FIGURES ARE CONSERVATIVE. HIGH LOADING OF FILTERS INCREASES (WIND FLUX AND SAMPLE SIZE). IT IS ESTIMATED THAT ACTUAL EFFICIENCIES RANGE FROM 10 TO 12 PERCENT HIGHER THAN INDICATED ABOVE.
- (4) DATA CONTINUING (DF).

CONFIDENTIAL

CONFIDENTIAL

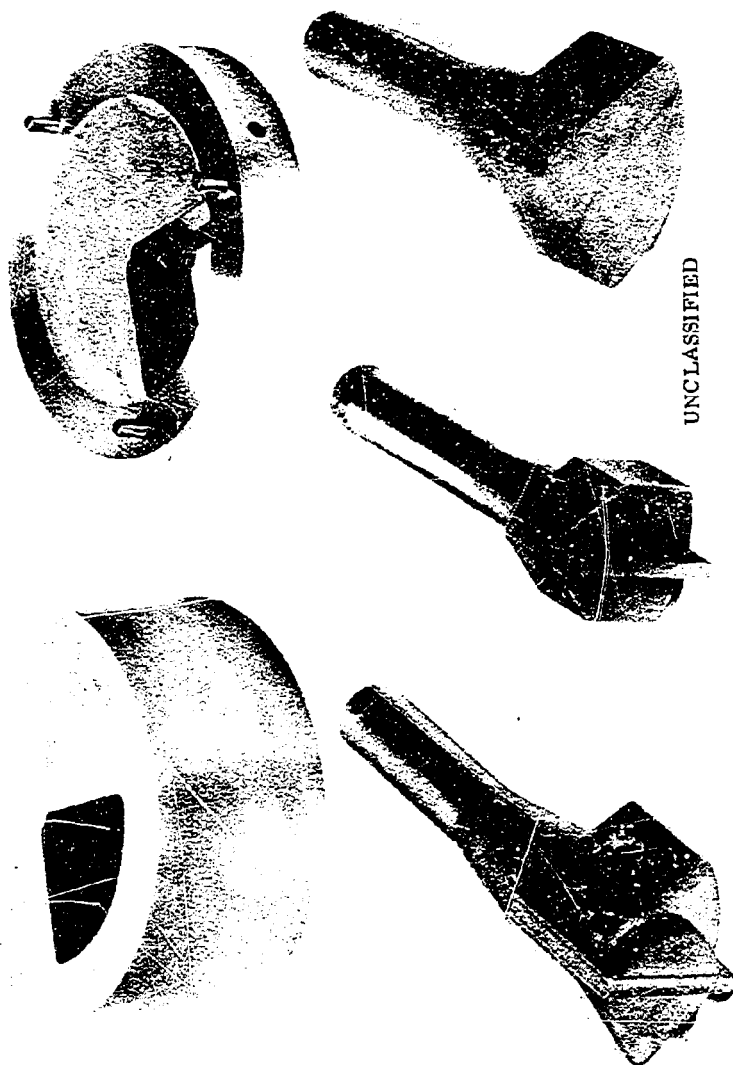

Figure 47, Sub-bomblet Loading Tools

CONFIDENTIAL

In view of the incompatibility of the current sub-bomblet case with the new BZ mixture, it was recommended that the sub-bomblet case material be changed to Nylafil. This is a 30 to 40% glass-filled nylon which is not affected by acetone. It is readily available and can be substituted in place of the Cyclac without any change to current tooling or fabrication methods.

(C) Upon inspection of the BZ-loaded sub-bomblets, it was concluded that the BZ fill was of poor quality. The mixture surrounding the quickmatch ignitor was very porous and broken away near the top. The fill density varied considerably throughout the unit.

(b) Testing - The results of the dissemination tests of the ten sub-bomblets with loaded Hooker 283 BZ are presented in table VIII.

(c) Post Test Analysis - From the analysis and the knowledge of the problems encountered in preparing these BZ-filled sub-bomblets for test, deficiencies were readily identified. The following pretest conditions and design weaknesses contributed to the low BZ dissemination efficiencies:

- . The sub-bomblet case material, Cyclac X-27, is incompatible with the acetone normally used in mixing the Hooker 283 BZ formula. Because of this material incompatibility, the standard loading procedures for the Hooker 283 were not utilized. Instead, a special dry-pressed procedure was used, which resulted in a very porous, low-quality fill.
- . The Quickmatch igniter found successful with the CS and smoke pyrotechnic mixes induces flaming when used with the BZ mixture. Upon ignition, the Quickmatch deposits relatively hot combustion products in the ignition trough that tend to cause flaming. The flaming thermally decomposes the agent, which results in a very poor agent recovery.
- . The two venting orifices provided in the current submunition are too large to maintain the pressure/temperature relationship necessary for the effective thermal generation of the Hooker 283 mixture.

Recommendations to solve these design problems and significantly improve the BZ dissemination efficiency of the sub-bomblet are presented in Section VII.

CONFIDENTIAL

TABLE VIII. AEROSOL RECOVERY DATA FROM THE
HOOKER 283 BZ-LOADED SUB-BOMBLETS

	TIME AFTER INITIATION (MINUTES)	GZ, μ	PERCENT C_{MAXIMUM}	PERCENT C_{MAXIMUM} AT t_0	INHALABLE AEROSOL, %	CASCADE-IMPACTOR DATA (12-MINUTE RECOVERY TIME DATA)		PARTICLE COUNT AT 3 MINUTES AFTER DISSEMINATION (MIRI COUNTER)			
						BZ I. BA., μ	MND, μ	PARTICLE SIZE, μ	NUMBER OF PARTICLES	PERCENT OF PARTICLES	CUMULATIVE PERCENT
TEST 1 (OBSERVATIONS: CLICK-WATCH UNIT INITIATED PROPERLY AND DID NOT FLAME; 2x.0 OF MIX; BURNING TIME, 17 SECONDS.)	2	530	22.6	25.5	3.6	1	5.2	1.0-1.4	4,334	52.3	52.3
	7	548	23.0			2	6.0	1.4-2.0	3,832	46.3	98.6
	12	640	26.8			3	47.7	2.0-2.6	109	1.3	99.9
	17	660	27.7			4	120.0	2.8-4.0	0		
	22	606	25.4			FILTER	100.0	4.0-5.6	1		
27	537	22.5				5.6-8.0	0				
									8,275		
TEST 2 (OBSERVATIONS: CLICK-WATCH UNIT; COVER NOT FLUSH WITH TOP; INITIATED PROPERLY AND DID NOT FLAME; 28.8 % OF PYROTECHNIC; BURNING TIME, 22 SECONDS.)	2	670	25.6	30.6	4.8	1	9.5	1.0-1.4	4,368	46.7	46.7
	7	767	29.0			2	6.5	1.4-2.0	4,723	50.5	97.2
	12	762	28.6			3	52.0	2.0-2.8	244	2.6	99.8
	17	750	27.9			4	82.5	2.8-4.0	5		
	22	780	29.4			FILTER	110.5	4.0-5.6	4		
27	672	25.6				5.6-8.0	1				
									9,345		
TEST 3 (OBSERVATIONS: CLICK-WATCH UNIT; CASE DISTORTED; COVER DID NOT FIT WELL; 27.7 % OF MIX FLAMED.)	7	45	1.8		0.27	1		1.0-1.4	608	71.0	71.0
						2		1.4-2.0	174	20.5	91.3
						3		2.0-2.8	52	6.1	97.4
						4		2.8-4.0	16	1.9	99.3
						FILTER		4.0-5.6	4	0.4	99.7
						5.6-8.0	2		100.0		
									856		

CONFIDENTIAL

CONFIDENTIAL

CONFIDENTIAL

TABLE VIII. AEROSOL RECOVERY DATA FROM THE HOOKER
283 BZ-LOADED SUB-BOMBLETS (Continued)

	TIME AFTER INITIATION (MINUTES)	BZ, μg	PERCENT C_{MAXIMUM}	PERCENT C_{MAXIMUM} AT T_0	INHALABLE AEROSOL, μg	CASCADE-IMPACTOR DATA (12-MINUTE RECOVERY TIME DATA)		PARTICLE COUNT AT 3 MINUTES AFTER DISSEMINATION (HTRI COUNTER)			
						BZ + BA, μg	MMD, μ	PARTICLE SIZE, μ	NUMBER OF PARTICLES	PERCENT OF PARTICLES	CUMULATIVE PERCENT
TEST 4 (OBSERVATIONS: QUICK-MATCH UNIT; INITIATED PROPERLY AND BURNED FOR 30 SECONDS; NO FLAME; 26.2 μ OF MIX.)	2	395	16.5	24.0	3.5	10.5	1.3	1.0-1.4	4,442	53.8	53.8
	7	370	15.2			7.0		1.4-2.0	3,635	44.0	97.8
	12	510	21.0			70.5		2.0-2.8	169	2.0	99.8
	17	453	18.6			66.5		2.8-4.0	2		
	22	410	16.9			112.0		4.0-5.6	0		
	27	360	14.9				5.6-8.0	1			
									8,249		
TEST 5 (OBSERVATIONS: QUICK-MATCH UNIT; INITIATED PROPERLY; OBSCURED BY SMOKE IN 5 SECONDS; HOLE BURNED IN TOP; TAPE STAYED ON AT CIRCUM- FERENCE; 27.7 μ OF MIX.)	2	576	35.7	39.6	6.1	10.0	0.96	1.0-1.4	4,368	44.4	44.4
	7	560	33.0			6.0		1.4-2.0	5,176	52.6	97.0
	12	645	37.8			48.0		2.0-2.8	303	3.0	100.0
	17	653	37.8			115.5		2.8-4.0	0		
	22	763	45.2			131.2		4.0-5.6	0		
	27	612	36.0				5.6-8.0	0			
									9,847		
TEST 6 (OBSERVATIONS: QUICK-MATCH UNIT; COVER FIT WELL; INITIATED PROPERLY BUT FLAMED AFTER 5 TO 10 SECONDS; 26.8 μ OF MIX.)	2	265	16.4	16.0	2.4	0.0	1.5	1.0-1.4	2,234	74.0	74.0
	7	218	13.2			2.0		1.4-2.0	691	22.9	96.9
	12	208	12.7			11.8		2.0-2.8	72	2.4	99.3
	17	202	12.1			106.2		2.8-4.0	17	0.6	99.9
	22	188	11.5			18.0		4.0-5.6	3		
	27	190	11.8				5.6-8.0	0			
									3,017		
TEST 7 (OBSERVATIONS: QUICK-MATCH UNIT; ORIFICE SIZE REDUCED TO 0.120 INCH; FLAMED; 27.2 μ OF MIX.)	2	144	8.7	10.4	1.6	8.5	1.5	1.0-1.4	2,203	41.6	41.6
	7	212	12.8			6.5		1.4-2.0	2,537	47.9	89.5
	12	165	9.8			8.0		2.0-2.8	396	7.5	97.0
	17	164	9.7			46.0		2.8-4.0	111	2.1	99.1
	22	131	7.8			21.8		4.0-5.6	44	0.8	99.9
	27	103	6.2				5.6-8.0	2			
									5,293		

CONFIDENTIAL

CONFIDENTIAL

CONFIDENTIAL

TABLE VIII. AEROSOL RECOVERY DATA FROM THE HOOKER
283 BZ-LOADED SUB-BOMBLETS (Concluded)

	TIME AFTER INITIATION (MINUTES)	BZ, μ i	PERCENT C _{MAXIMUM}	PERCENT C _{MAXIMUM} AT T ₀	INHALABLE AEROSOL, μ i	CASCADE-IMPACTOR DATA (12-MINUTE RECOVERY TIME DATA)			PARTICLE COUNT AT 3 MINUTES AFTER DISSEMINATION (HTRC COUNTER)		
						STAGE	BZ + BA, μ i	MMD, μ i	PARTICLE SIZE, μ i	NUMBER OF PARTICLES	PERCENT OF PARTICLES
TEST 3 OBSERVATIONS: QUICK-MATCH UNIT; COVER NOT FLUSH; 2 ADDITIONAL HOLES, 0.125 INCH IN DIA- METER, DRILLED IN TOP; FLAMED AFTER 3 SECONDS; 26.6 g OF MIX.	2	210	13.0	13.0	1.9	7.0	2.0	1.0-1.4	2,738	72.7	72.7
						6.0		1.4-2.8	886	23.6	96.3
						11.2		2.8-4.0	110	2.9	99.2
						61.5		4.0-5.6	23	0.6	99.8
						12.0		5.6-8.0	2		
									3,703		
TEST 9 OBSERVATION: NO TEST DUE TO IGNITION MALFUNCTION.											
TEST 10 OBSERVATIONS: GRADED PYROFUZE; INITIAL WELL; THICK SMOKE; COULD NOT GET BURNING TIME; 28.6 g OF MIX.	2	560	32.4	35.0	5.5	16.0	0.68	1.0-1.4	3,634	34.6	34.6
	7	625	35.6			8.5		1.4-2.8	5,928	56.5	91.1
	12	558	31.6			36.0		2.8-4.0	934	8.9	100.0
	17	573	32.3			85.0		4.0-5.6	4		
	22	524	30.2			147.0		5.6-8.0	0		
	27	552	32.0						10,500		

CONFIDENTIAL

CONFIDENTIAL

2. MIL-STD and Preflight Demonstration Tests

(U) The preprototype bomblet was subjected to MIL-STD-810A specifications, air-gun tests, and static ejection tests.

(U) a. MIL-STD Tests - The results of all testing to MIL-STD-810A requirements are summarized in table VIII. After the bomblets were subjected to each of the specified MIL-STD tests, each was ejected from an SUU-13/A tube and statically functioned. As shown in table IX, the primary fuze, pyrocore initiator, and explosive bolt of all but four bomblets functioned perfectly. Of these four the primary fuze functioned properly, but an improperly prepared pyrocore initiator prevented the remainder of the ignition train from functioning. This deficiency in assembly was corrected immediately.

(U) All but seven of the live, smoke-loaded sub-bomblets functioned properly. The primary causes of the sub-bomblet failures were:

- The asphalt sealant used to seal the case crimp of the FMU-65/B, being too fluid, seeped into the fuze mechanism and locked up the internal gearing.
- The metal burr on the housing causes the firing pin to impinge on the detonator.

Both of these problems were resolved by appropriate design changes.

(U) b. Flight Simulation (Air Gun) Tests - Three series of dynamic tests were conducted with live bomblets and varying quantities of live sub-bomblets. The bomblets were launched from the high pressure air gun shown in figure 48 to simulate the dynamic environment of a flight drop.

(U) The first series of tests involved six bomblets. These tests were conducted primarily to determine launching modes and nozzle fixturing, and to gauge launching velocities to ensure the bomblets were experiencing

TABLE IX. MIL-STD-810A TEST SUMMARY, BLU-80/B BOMBLET

MIL-STD-810A TEST METHOD	BOMBLET ASSEMBLY DESCRIPTION	QUANTITY	RESULTS	REMARKS
METHOD 501 HIGH TEMPERATURE	COMPLETE LIVE CLUSTERS CONTAINING 2 SMOKE LOADED AND 30 INERT SUB-BOMBLETS EACH.	4	3 CLUSTERS FP ⁽¹⁾ AFTER SUBMISSION 1 CLUSTER FTF ⁽²⁾ AFTER SUBMISSION ALL BUT 2 SMOKE LOADED SUB-BOMBLETS FP.	FAULTY PYROCORE CUT-OFF CAUSED THE ONE FAILURE. FMU-65/B FUZE PROBLEMS DISCUSSED IN TEXT CAUSED SUB-BOMBLET FAILURES.
METHOD 502 LOW TEMPERATURE	SAME AS METHOD 501.	4	3 CLUSTERS FP AFTER SUBMISSION 1 CLUSTER FTF AFTER SUBMISSION ALL SMOKE LOADED SUB-BOMBLETS FP.	FAULTY PYROCORE CUT-OFF CAUSED THE ONE FAILURE.
METHOD 504 TEMPERATURE/ALTITUDE CYCLE	SAME AS METHOD 501.	4	3 CLUSTERS FP AFTER SUBMISSION 1 CLUSTER FTF AFTER SUBMISSION ALL BUT 2 SMOKE LOADED SUB-BOMBLETS FP.	FAULTY PYROCORE CUT-OFF CAUSED THE ONE FAILURE. FMU-65/B FUZE PROBLEMS DISCUSSED IN TEXT CAUSED SUB-BOMBLET FAILURES.
METHOD 507 HUMIDITY	SAME AS METHOD 501.	4	3 CLUSTERS FP AFTER SUBMISSION 1 CLUSTER FTF AFTER SUBMISSION ALL BUT 3 SMOKE LOADED SUB-BOMBLETS FP.	FAULTY PYROCORE CUT-OFF CAUSED THE ONE FAILURE.
METHOD 511 VIBRATION	SAME AS METHOD 501 EXCEPT 32 INERT SUB-BOMBLETS WERE USED AND 16 OF THESE CONTAINED FMU-65/B FUZES WITH INERT DETONATORS.	4	ALL 4 CLUSTERS FP AFTER SUBMISSION ALL FMU-65/B FUZES FP.	FMU-65/B FUZE FUNCTION IS QUALIFIED BECAUSE THERE WAS IMPROPER FIRING PIN IMPINGEMENT IN THESE AS DISCUSSED IN THE TEXT.
METHOD 516 SHOCK	SAME AS 514 EXCEPT DUMMY FMU-65/B FUZES WERE USED IN THE SUB-BOMBLETS.	4	ALL 4 CLUSTERS FP AFTER SUBMISSION UNCLASSIFIED	THIS PROBLEM, HOWEVER, HAS SINCE BEEN RESOLVED.

(1) FP = FUNCTIONED PROPERLY
(2) FTF = FAILED TO FUNCTION

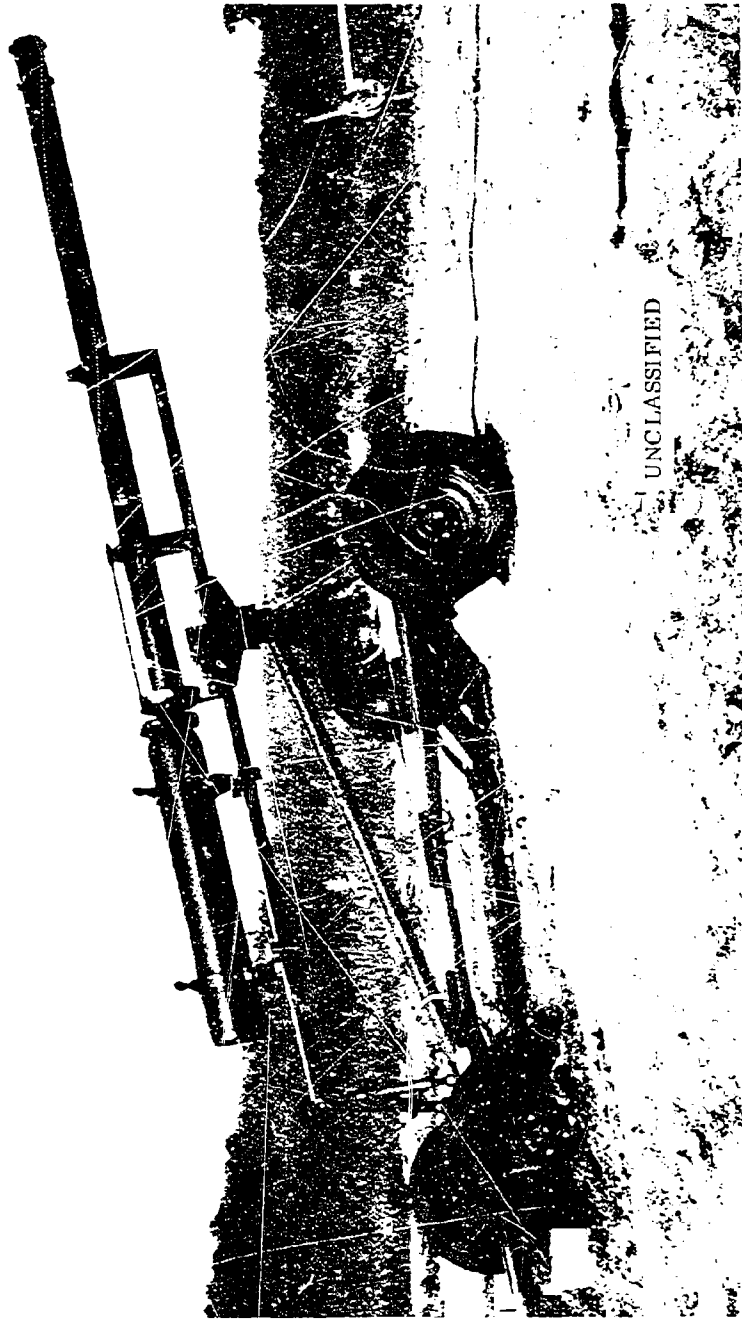

Figure 48. Air Gun, 4.6-inch High Pressure

a realistic dynamic environment. When tested, these six bomblets did not function as designed. The high magnitude, destructive setback forces experienced damaged various fuzing components in each test and prevented bomblet function. The conclusions reached were that further testing had to be accomplished to better define the air gun launch environment.

(U) The second series of tests involved ten bomblets. The objective was to resolve the problems experienced with the initial test series and to obtain some degree of functional confidence in dynamic bomblet function. During this series it was determined that the sabot (bomblet launching guide) and gun breech diaphragm had to be modified to obtain proper launch. Testing with appropriate modifications to these items resulted in four successful bomblet tests. The other six did not function properly due to damage to the primary (modified BLU-4) timer in the bomblet. At the completion of this test series it was concluded that the timer must be specially reinforced to withstand the air gun setback loads and that another series of tests be conducted.

(U) The third series of dynamic tests prior to the demonstration tests, fourteen bomblets were tested, and all but six functioned properly. Four of the six again experienced setback damage when they were launched at velocities near 600 knots. The other two dudged because of improper function of the cluster ignition train. With eight of the fourteen having functioned properly at velocities near 450 knots it was decided to conduct the final preflight demonstration tests at this velocity.

(U) The final preflight demonstration tests consisted of firing four bomblets from the airgun at 600 fps. Only one of the four bomblets demonstrated complete and proper function. The results of the tests are summarized below in the order in which the tests were conducted:

Bomblet No. 1 Good parachute deployment. Cluster malfunctioned because the drive spring in the primary fuze came loose upon bomblet launch.

- Bomblet No. 2 Good parachute deployment. Cluster functioned properly, dispersing the 32 sub-bomblets in an elliptical pattern approximately 270 feet long and 110 feet wide. Cluster release altitude was approximately 55 feet. Of the 16 live sub-bomblets (red smoke) 3 dudded due to FMU-65/B fuze malfunctions and 2 dudded when the covers broke loose upon ground impact. The remaining 11 sub-bomblets worked properly.
- Bomblet No. 3 Good parachute deployment. Cluster functioned; however, the explosive bolt fractured upon leaving the air gun muzzle. This resulted in premature expansion of the sub-bomblet cluster and, consequently, premature arming of the sub-bomblet fuzes. Therefore, a number of the sub-bomblets functioned prior to impact with the ground. Of the 16 live sub-bomblets, 8 failed to function properly. Three of these eight duds were in one stack of submunitions, which hung up in the fractured cluster container, and were not released until after ground impact. Thus, the three fuzed sub-bomblets in the stack were not able to arm before impact and, therefore, did not initiate upon impact. The other five duds were due to malfunctioning FMU-65/B fuzes, which included two insensitive detonators.
- Bomblet No. 4 Good parachute deployment. Bomblet dudded due to damage to the primary fuze, caused by setback forces.

An analysis of the demonstration tests resulted in the following:

- . The bomblet malfunctions were due to problems inherent in launching from the airgun and not to bomblet design deficiencies. Further airgun testing did not appear warranted. Strengthening of the bomblet to withstand the loads imposed by the air gun would be quite costly, and thus undesirable, since the bomblet is physically and functionally compatible with the SUU-13/A dispenser from which it will be delivered.
- . Parachute deployment was very good and initiated the primary fuze release mechanism in all cases.
- . The FMU-65/B malfunctions were due primarily to a "partial arm" condition. This condition was caused by a combination of escapement gear misalignments and setback loads on the fuze. The misalignment problem was inherent to the fuze parts and assembly technique. Corrective actions were taken and the necessary design improvements were incorporated.

- . Three of the FMU-65/B fuzes used in the tests had insensitive detonators. The detonators were hand-loaded by R. Stresau Labs, who admitted to difficulties with the loading tools which could account for the failures. All of the detonators used in subsequent bomblets were taken from a special FGI lot from Lone Star Arsenal.
- . The bond between the sub-bomblet covers provided by acetone was susceptible to failure. The use of acetone was replaced by a filler type epoxy.

(U) Because of the inconclusive results of these tests, another series of proof tests were conducted which involved the static ejection of seven bomblets from SUU-13/A tubes. All bomblets were completely operable after ejection. The photographs in figure 49 are typical of the results of these ejection tests.

3. Development Flight Tests

(U) Ten bomblets containing inert sub-bomblets (but with functional cluster fuzing) were flight tested. The results of the tests are summarized in table X. Except for an apparently insensitive M55 detonator in one of the explosive bolts and the insufficient expansion of one bolt, all components of the ten bomblets demonstrated the desired function when delivered by the tactical fighter aircraft.

(U) A review of the results of the flight tests, conducted as part of contract item 2, indicated that the overall functional characteristics of the bomblet were satisfactory. The following minor design changes were incorporated into the prototype test models to improve reliability.

- . The rivets retaining the parachute shield assembly to the drogue line were strengthened to prevent the shield from breaking free upon bomblet ejection.
- . The explosive bolt collar was modified slightly to allow greater cluster expansion and thus more reliable sub-bomblet release.
- . The O-ring seal location on the top plate was changed to prevent possible binding of the parachute ring upon ejection.

CONFIDENTIAL

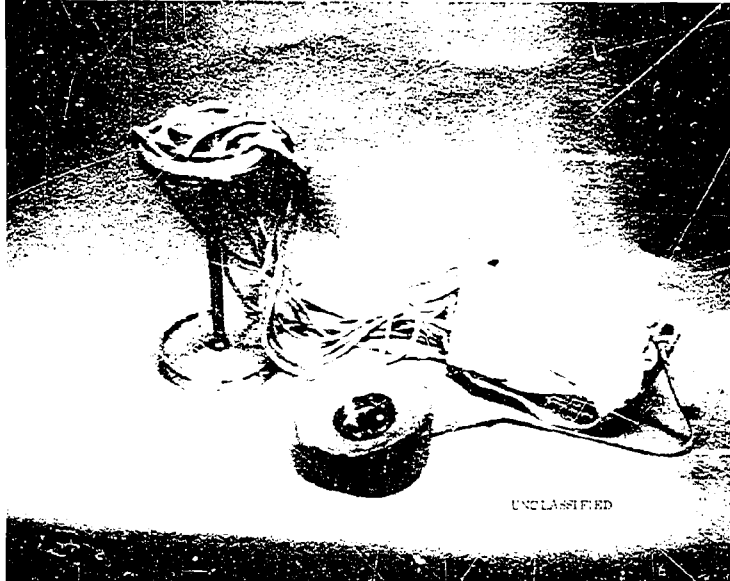

Figure 49. BLU-26 Bomblet after Static Ejection Test: (Top) Bomblet Cluster and Sub-bomblets: (Bottom) Cluster Hardware Without Sub-bomblets.

-97-

CONFIDENTIAL

(This page is Unclassified)

CONFIDENTIAL

TABLE X. AIR FORCE FLIGHT TEST SUMMARY

TEST BOMBLET NUMBER	DELIVERY ALTITUDE (FEET)	DELIVERY VELOCITY (KNOTS)	REMARKS
1	300	225	LOW SPEED DELIVERY TO CHECK FOR ABORT - UNIT ABORTED PROPERLY ⁽¹⁾ .
2	300	225	LOW SPEED DELIVERY TO CHECK FOR ABORT - UNIT DID NOT ABORT, BUT FUNCTIONED PROPERLY ⁽¹⁾ .
3	300	300	UNIT FUNCTIONED PROPERLY.
4	300	300	UNIT FUNCTIONED. BOLT DID NOT EXPAND SUFFICIENTLY TO RELEASE SUBMUNITIONS PRIOR TO GROUND IMPACT.
5	300	400	UNIT FUNCTIONED WITH THE EXCEPTION OF THE M55 DETONATOR IN THE EXPLOSIVE BOLT.
6	300	400	UNIT FUNCTIONED PROPERLY.
7	300	500	UNIT FUNCTIONED PROPERLY.
8	300	500	UNIT FUNCTIONED PROPERLY.
9	300	600	UNIT FUNCTIONED PROPERLY.
10	300	600	UNIT FUNCTIONED PROPERLY.

CONFIDENTIAL

NOTE: (1) BOMBLET IS DESIGNED FOR 100 PERCENT ABORT AT DELIVERY VELOCITIES LESS THAN 140 KNOTS AND 100 PERCENT FUNCTION AT VELOCITIES GREATER THAN 240 KNOTS. THE 225-KNOT TEST IS IN THE SO-CALLED GREY AREA WHERE EITHER FUNCTION OR ABORT MAY OCCUR.

CONFIDENTIAL

- . The drive spring in the sub-bomblet fuze was strengthened to insure arming in severe g-load environments caused by tumbling and/or in the event of slight gear friction in the escapement mechanism.

(U) A total of 123 bomblets incorporating the above changes and containing varying quantities of inert, smoke, and CS-filled sub-bomblets are subsequently assembled and delivered to the Air Force for continued flight test evaluation.

CONFIDENTIAL

(This page is Unclassified)

CONFIDENTIAL

SECTION VI

CONCLUSIONS AND RECOMMENDATIONS

(C) The work performed has indicated that a nonhazardous bomblet of the type developed can be delivered by a tactical aircraft from a SUU-13/A dispenser, and will effectively disperse itself over the target. All components of the bomblet were shown to be theoretically nonhazardous to personnel in the target area.

(C) The conclusions and recommendations for this bomblet will be discussed in two categories: BLU-30/B cluster bomblet concept applications, and sub-bomblet improvements with BZ.

A. BLU-30/B CLUSTER BOMBLET CONCEPT APPLICATIONS

(C) As delineated in this report, the BLU-30/B bomblet has demonstrated its physical and functional compatibility with the SUU-13/A dispenser and, especially with CS indications are that relatively large geographical areas can be covered to a 30% casualty level; i. e., single bomblet coverage of 10,000 m² with CS and 2,500 m² with BZ. Theoretical area coverage effectiveness predictions indicate that with CS this system would exceed the CBU-30 by 4% to 6%. Realistic effectiveness comparisons with BZ are not available. Another significant comparison to the CBU-30 system is that the BLU-30 bomblet provides an abort safety feature in the event of inadvertent ejections from the aircraft, whereas this is not available with CBU-30 system.

(U) It is recommended that a short design study effort be conducted to establish which dispenser is most effective with this type bomblet and to formulate the necessary bomblet design drawings. At the completion of this effort it is felt that an engineering development program, as opposed to advanced development, be conducted to verify its cost/effectiveness qualifications for standardization.

(U) Subsequent Air Force testing revealed additional development would be required for the BLU-30/B submunitions to alleviate problems of submunition break-up on ground impact and excessive pressure build-up within the submunition.

CONFIDENTIAL

B. SUB-BOMBLET IMPROVEMENT WITH BZ

(C) The BLU-30/B sub-bomblet disseminated CS with reasonable efficiency, but not BZ. Loading difficulties were experienced because a new BZ formulation (see table XI) is not compatible with the sub-bomblet material. The tests also showed that the dissemination technique could be improved for both design changes, along with recommendations for a short program which would improve the sub-bomblet for the dissemination of BZ.

Recommendation 1: Fabricate the Sub-bomblet body from Nylafil (a 30 to 40 percent glass-filled Nylon).

(U) The loading tests with BZ showed that the acetone currently used in the Hooker 283 formulation is not compatible with the Cyclocac plastic from which the current sub-bomblet is fabricated. A materials search has resulted in the recommendation of Nylafil. Nylafil is compatible with all elements in the Hooker 283 mix and is stronger than Cyclocac. Nylafil is also adapted to the current sub-bomblet tooling and fabrication techniques.

(U) By fabricating the submunition from Nylafil, the loading procedure recommended for the Hooker 283 BZ mix may be used. The purpose of the acetone in the Hooker 283 mix is two-fold; it desensitizes autoignition due to intergranular friction and heating during loading, and it acts as a binder.

(U) The dry BZ/pyrotechnic fill could not be pressed uniformly. Good consolidation could not be achieved without intergranular binding, and the result was a loose, crumbly fill that was detrimental to consistent ignition and thermal generation.

Recommendation 2: Incorporate a Completely Consumable Ignitor Element.

(U) The high temperature combustion products resulting from the current quickmatch ignition technique aided in flaming of the BZ pyrotechnic mix. It is recommended that a completely consumable ignition element, such as a

CONFIDENTIAL

TABLE XI. HOOKER 283 BZ FORMULATION

ELEMENT	WT %	PARTS BY WEIGHT AND VOLUME (PER 5000-GM BATCH)
BZ	55.00	2750.0 GMS
KClO ₃	20.25	1012.5 GMS
S	7.95	397.5 GMS
NaMCO ₃	6.00	300.00 GMS
283 RESIN	10.80	540.00 GMS
METHYLETHYL KETONE PEROXIDE	0.105	5 ML-60% PURE IN DIMETHYLPHALATE
COBALT NAPHTHANATE	0.0132	- 1 ML PURE BASIS
ACETONE	ADDED TO RESIN AS 5.27 WEIGHT BY PERCENT OF THE FINAL DRY MIX	331 ML
		UNCLASSIFIED

Pyrofuze* element, can be used to eliminate this problem. Pyrofuze is of bimetallic composition; when brought to the ignition temperature, its elements will alloy violently and exothermically, resulting in deflagration without the support of oxygen. The alloyed elements are almost completely consumed (approximately 95 percent). Easily ignitable by the flash output of the modified FMU-65/B fuze, the pyrofuze element supplies a sufficient amount of thermal energy (minimum temperature of 2800°C) to ignite the BZ pyrotechnic fill. There is no shock or detonation that could break up the agent fill.

Recommendation 3: Reduce the Diameter of the Venting Orifices in the Sub-bomblet Body.

(U) The properly mixed and loaded BZ pyrotechnic mixture burns within a specific temperature range, and the pressure buildup within the confines of the sub-bomblet directly affects this thermal reaction. If the pressure buildup due to the thermal reaction is not sufficiently vented, the reaction pressures will eventually exceed the strength of the sub-bomblet confines, and the unit will detonate violently. On the other hand, if the venting or pressure relief is too great, the resulting pressure temperature balance is such that the chemical reaction is in the oxygen-rich flaming state, and the flame temperature is high enough to thermally decompose the BZ filled sub-bomblet.

(U) By experimenting further with reduced venting ports, the pressure temperature relationship best suited to this sub-bomblet can be obtained. With the optimum vent size established and the use of a pyrofuze ignitor (Recommendation 2), the result will be a large improvement in the BZ agent aerosolization.

*Trade name for Pyrofuze Corporation -- An affiliate of Sigman Cohn Corp., Mt. Vernon, N. Y.

APPENDIX I PARACHUTE STUDY

SUMMARY

(U) The recommended parachutes for use with the nonhazardous bomb are the ring-slot parachute and the cruciform (French Cross) parachute. A literature search was conducted on the characteristics and performance of parachutes and is summarized herein. The following discussion is confined to the relative differences between parachute types and when and where a particular parachute design would be used. If the reader would prefer more details, a bibliography is given of the reports that were either used in writing this discussion, or have detailed information concerning parachute design characteristics and/or performance.

(U) In general, solid canopy parachutes are restricted to subsonic operation; ribbon parachutes allow transonic operation with special designs extending the operation into the supersonic regime; and ballutes, drag brakes and trailing cones used for deceleration at hypersonic speeds. Rotor blades are normally used when controlled descent is desired. Cruciform and wagon-wheel types parachutes may be considered special types of solid canopy designs or special types of ribbon canopy designs, since they exhibit some characteristics of both the solid and the ribbon parachutes.

INTRODUCTION

(U) With the advent of space travel and supersonic aircraft, a need was created for light weight, light speed recovery systems. The search for such a system understandably turned to parachutes. The majority of the literature of parachute design and performance has been written in the last 10 years. Prior to the past decade, very little research was done on improving parachute design, the solid cloth, circular canopy design being

the most commonly used parachute. The one main exception to the circular canopy was the guide surface designed by H. G. Heinrich during World War II in Germany. The guide surface parachute is a more expensive and intricate design than the circular canopy parachute and exhibits improved stability and drag characteristics. The guide surface parachute is used mainly as a personnel chute with limited use wherever high stability is required by other air dropped items.

(U) The nonhazardous bomblet requires a retardation system operable in the subsonic and transonic speed regimes near sea level atmospheric conditions. It is also imperative for the system to be packaged as small as possible to allow maximum volume for the payload. With these requirements, the search for a retardation system turned to the field of parachutes, and a literature review was conducted of the current parachute state-of-the-art.

(U) The following discussion lists the parachute design and performance parameters pertinent for a comparative analysis of the various parachutes and the parachute requirements pertinent to the nonhazardous bomblet. Then the various parachutes are categorized and the parachute types applicable to the nonhazardous bomblet requirements are discussed. Finally, the parachutes having the most advantages applicable to the nonhazardous bomb are recommended.

(U) Design and Performance Parameters: The primary parameters used for describing a parachute's characteristics and performance are as follows:

- Parachute deployment time - the time required for a parachute to be ejected from the carrier vehicle, stretch the lines, and start to open.
- Snatch force - the force experienced by the lines when they become taut at the end of the deployment period (can be the maximum force if the opening loads are small).

- Filling time - the period between the end of the deployment time and when the parachute is inflated (at supersonic speeds, the inflated shape of parachutes is normally smaller than the subsonic inflated shape).
- Opening force - the force experienced by the lines when the parachute inflates (usually the peak force experienced by the parachute).
- Stress distribution - the stress experienced by the parachute material (maximum stress and strain is normally experienced circumferentially rather than radially).
- Dynamic stability of parachute - the oscillatory or coning characteristics of the parachute.
- Drag - the amount of retardation force created by the parachute with respect to the area of the parachute material.
- Subsystem reliability - the ability of the parachute package to consistently deploy, open, and function as designed.

(U) Describing a parachute with the above parameters will allow to complete and accurate description to be made of the parachute's performance. Other design considerations for a parachute are weight, packaging volume, complexity and cost.

(U) Requirements: The requirements of the parachute system for the nonhazardous bomblet are dictated by the performance requirements of the bomb. Throughout the delivery envelope, the parachute must -- within 0.45 second - slow the bomb to a velocity which will allow the sub-bomblets and the bomblet case to impact the ground with energies less than 33 ft-lb. The delivery envelope has a maximum and a minimum Mach number of 1.2 and 0.212, respectively, and a maximum and a minimum altitude of 700* and 50 feet, respectively. Past analyses and test have indicated that a parachute having a drag area ($C_D A$) of 1.017 square feet should satisfy these requirements. A compatible parachute diameter of approximately 1.5 feet will produce this drag area - smaller diameter is required if the parachute displays large drag characteristics and larger diameter is required if the parachute displays low drag characteristics.

*The 700-foot maximum delivery altitude would be applicable if pyrotechnic delay fuzing were used in the nonhazardous sub-bomblet.

(U) Parachute Categories:

Solid cloth: The solid cloth type of parachute has been, in the past, the more common type of parachute and contains such designs as the flat circular, the extended skirt, the conical or shaped, the shaped gore or hemispherical, and the guide surface. These parachutes exhibit a drag coefficient between 0.70 and 0.95, depending upon their fabric porosity for stability, and are deployed primarily in the subsonic regime. Except for the guide surface, they display oscillations of ± 20 to 30 degrees. The guide surface parachute (personnel ribless or modified ribless) is a high stability design parachute and exhibits oscillations of less than ± 5 degrees. The high opening shock loads of the solid canopy parachutes at transonic speeds normally prohibits their use at other than subsonic speeds. The guide surface parachute has a low opening shock factor but develops such high frequency oscillations during opening at dynamic pressures greater than 1700 psf that, in many cases the parachute has disintegrated, and in all cases was extensively damaged.

(U) Ribbon: The ribbon type canopy is made up of fabric strips with spaces between the strips. The flat circular design ribbon parachute has concentric strips of fabric attached to radial strips of fabric. The ring slot parachute is similar except radial lines replace the radial fabric strips. Other types of ribbon parachutes are the conical, the ring sail, the hemisflo and the equiflo. The equiflo and the hemisflo parachute are especially designed for supersonic deployment and may be described as an extended skirt flat circular ribbon parachute and an extended skirt hemispherical ribbon parachute, respectively. The recommended operating range for the ribbon parachutes extends into the low transonic speed regime, with the equiflo and hemisflo parachutes extending into the supersonic regime.

(U) For high speed parachute deployment the porosity of the canopy fabric and the spacing between the ribbons were found to be quite significant in obtaining satisfactory operational characteristics. To maintain a

high level of drag and stability, the canopy fabric should be between 10 and 20 percent porous. Increasing the spacing between the ribbons slows down the required opening time, lowers the opening shock and increases the opening stability characteristics. At Mach 1.2 the total parachute porosity including fabric porosity and spaces between the ribbons must be greater than 15 percent to avoid violent oscillations, but less than 40 percent to avoid inflation instability due to the longer opening time. Ribbon parachutes have compatible drag coefficients with the solid cloth canopy if based on total fabric area and exhibit very good stability characteristics having oscillation angles less than ± 5 degrees.

(U) Rotating: Rotating parachutes or rotor blades require swivel between the parachute and the deployment vehicle. The drag characteristics are usually better but the designs are much more intricate and the total package heavier than for other parachutes. The rotafoil canopy is similar to the flat circular type with an opening in each gore which causes the canopy to rotate. The more stable designs of the rotafoil have less drag than the less stable designs. The rotafoil has good opening characteristics with low opening shock loads. Another type of rotating parachute is the vortex ring canopy. The vortex ring canopy exhibits excellent drag and stability characteristics but has poor opening reliability. Rotor blade decelerators exhibit excellent stability, high drag and reliable opening characteristics. The design must be integrated with the vehicle and is heavier than a compatible parachute system. The rotor blade is normally selected when some degree of landing control is desired.

(U) Other: Other types of parachutes or decelerators include the cruciform (French cross and Raven R-Plus), ballutes, Avco drag brake, and trailing cones. Ballutes, Avco drag brake, and trailing cones are bulkier and heavier than compatible parachutes and are considered when high Mach number and high altitude operations are required. The cruciform parachute finds favor because of its design simplicity. It exhibits good stability

characteristics -- oscillations less than ± 10 degrees for a proper design. It has a low opening shock load and excellent opening characteristics. Data on high speed operation (low transonic regime) is not available, but it is felt that this will present no problem; the panels can be easily slotted for a ribbon variety if necessary. Drag characteristics are compatible to the solid canopy design based on the total fabric area.

(U) Types Applicable to the Nonhazardous Bomblet: The solid canopy type of parachute cannot withstand the maximum opening conditions of Mach 1.2 and 50 feet altitude (corresponding dynamic pressure of 2135 psf). The other types of parachutes can be applied to the nonhazardous bomblet, some more readily adaptable than others. Rotating type parachutes, rotor blades ballutes, Avco drag brake, and cone decelerators will add more weight to the system and require considerable design development for successful integration with the nonhazardous bomblet. The cruciform parachute characteristics at Mach 1.2 are not known, but this parachute has been deployed successfully at high subsonic speeds and can be easily changed to a ribbon type, if required for higher deployment speeds. Ribbon type parachutes have demonstrated their ability to deploy successfully at transonic speeds; however, at supersonic speeds they require special designs to withstand the increased fabric flutter and opening oscillations.

RECOMMENDATIONS

(U) Two parachutes are recommended for possible use with the nonhazardous bomblet: the ring-slot and the cruciform parachutes. Both exhibit excellent characteristics in the required operating range and are of simple construction. However, the cost of a cruciform parachute is significantly lower than the ring-slot parachute. With the ability to "spill" air around the canopy because of its crosstype design, the cruciform parachute has an excellent chance of satisfying the Mach 1.2 opening requirements without a ribbon construction. If a ribbon construction is required on the cruciform parachute, the parachute must be increased slightly in size to maintain

the same drag level. The ring-slot is a ribbon type parachute that will satisfy the requirements of the nonhazardous bomblet and is the simplest construction design of the ribbon type parachutes. Other ribbon type parachutes may exhibit better characteristics at higher opening speeds, but these are quite similar in performance to the ring-slot for the flight conditions specified herein. Since they are of more complex construction than the ring-slot, they are not recommended.

APPENDIX II
SUMMARY OF LITERATURE SEARCH FOR
IMPROVED BZ AND CS PYROTECHNIC FORMULATIONS

Related Studies

(U) The Dow Chemical Co., under contract to Edgewood Arsenal,¹ conducted various studies on pyrotechnic compositions for thermally generating chemical agents. For the pressed grain compositions of BZ and CS, such fuels as the energetic nitrogen salts (Mg- HNO₃ and EBS) and the azide salts (TAZ and THA) have been tried along with small quantities of a catalyst. In some cases the resultant burning characteristics are good (yields of 31 to 41%); however, most of these fuels have limited compatibility with the agents CS and BZ, and must be studied further before definite conclusions can be made as to their overall effectiveness as improved thermal generating fuels. Another fuel which has shown most promise, particularly with CS (60% agent recovery), is the sulphur nitrogen fuel DTB. However, this fuel has not yet been optimized, and studies are continuing with DTB and other sulphur nitrogen fuels to increase the burning rates of CS.

(U) Dow Chemical² also studied improvements in castable CS and BZ mixes. The most promising results of these studies has been the development of a castable, polymer-bonded CS formulation. The principal problem with this polymer fuel composition has been the limited compatibility of CS with the required monomers, curing agents, and additives. To date, the agent yields with this fuel are about 1/2 to 3/4 of the best values obtained with the high-efficiency pressed grain compositions. Continuing studies in this field are aimed at optimizing the castable formulations for agent yield,

¹ New Concepts in Pyrotechnic Fuels for the Thermal Dissemination of Chemical Agents; RPT. PD-8-65, Dow Chemical Corp., 1 July 1965.

² The Development and Demonstration of a Caseless Munition Concept - ATL-TR-65-99.

combustion, castability, curing, and physical properties.

(U) Optimum Castable Formulation for BZ Agent - The results of the literature search and discussions with cognizant personnel indicated the following optimum castable pyrotechnic formulation for BZ:

- 18.0% Binder (Equal parts by weight of polyethylene glycols polymerized with toluene diisocyanate)
- 27.5% Potassium Chlorate
- 4.5% Sulphur
- 55.0% Granulated BZ

When extruded or cast into shape, the resulting mixture densities ranged from 1.0 to 1.1 gms/cc, which is nearly identical to the standard pressed mix densities. The final shape exhibits excellent mechanical properties. The resultant mixtures have been shown feasible for use in pyrotechnic compositions for thermal dissemination of BZ (50 to 55% agent recovery), but have not yet been fully qualified or standardized for munition usage.

(U) Optimum Castable Formulation for CS Agent - The studies indicated the following optimum castable composition for thermally disseminating CS:

- 15.0% Binder (Same as for BZ formulation described above)
- 30.0% Potassium Chlorate
- 15.0% Powdered Sugar
- 40.0% CS

This CS Mixture was found acceptable for thermal dissemination, yielding 40 to 50% agent recovery. Here again, however, standardization has not been made and further developmental investigations are being conducted.

APPENDIX III
BOMBLET TEST AND PROTOTYPE PRODUCTION PROGRAM

I. INTRODUCTION

(U) This program consisted of three tasks:

- (1) Dissemination testing of CS pyrotechnic bomblets
- (2) Dissemination testing of BZ pyrotechnic bomblets
- (3) Prototype production of 160 CS pyrotechnic bomblets.

These three tasks were completed and the results are presented in this report. For the testing phases of the program, data are presented for the burning time of the bomblets, dissemination efficiency, and particle size of the disseminated agents.

II. TESTS OF CS BOMBLETS

(U) The data for the tests of the CS loaded bomblets appear in Tables III-1 to III-10 of this report. With the exception of the bomblets prepared for Tests 5 and 6, all pressing was done dry. In Test 1 the bomblet was prepared by pouring a weighed amount of the pyrotechnic mix into the funnel, inserting the punch from the top, and pressing. This procedure resulted in a cake which was dense and highly compressed in the center portion; it was loose and crumbling in the thicker outer sections. It was evident that this poor result was due to poor distribution of the material and inability of the material to flow under pressure. Subsequent dry pressing was done by inverting the funnel and forming punch, pouring the mix onto the surface of the punch, covering with the die, moving the punch toward the die to immobilize the mix, inverting and pressing. This procedure resulted in better distribution of the mix and yielded cakes which were stronger and did not

CONFIDENTIAL

TABLE III-1. DATA FOR TEST CS-1

Observations: Pressed dry at 5600 lb; crude fill, quite porous and fragile; 29.5 g of pyrotechnic mix; burning time 20 to 25 sec.

Time, min.	CS, μ g.	% C _{max}	% C _{max} at T ₀	Inhalable Aerosol, g	Cascade-Impactor Data		Particle Count at 3 min after Dissemination (IITRI Counter)			
					Stage	CS, μ g.	MMD, μ	Particle Size, μ	Number of Particles	% of Cumulative Particles
3.5	3500	57.3*	59.0*	7.0*	1	Trace	1.0-1.4	2757	21.7	21.7
8.5	3800	45.6*			2	Trace	1.4-2.0	6891	54.1	75.8
13.5	3375	55.0*			3	51.0	2.0-2.8	3038	23.9	99.7
18.5	3275	53.0*			4	265.0	2.8-4.0	31	0.24	99.98+
23.5	3075	50.4*			Filter	4.5	4.0-5.6	1		
28.5	2675	46.6*					5.6	1		

* These figures are conservative. High loading of the filters decreased air flow and sample size.

CONFIDENTIAL

CONFIDENTIAL

CONFIDENTIAL

TABLE III-2. DATA FOR TEST CS-2

Observations: Pyrotechnic mix ground and -10 +40 mesh fraction used; pressed 5600 lb; crude fill, porous and fragile; 29.5 g of pyrotechnic mix; did not ignite; defective fuse.

Time, min	μg	% C_{max}	% C_{max} at T_0	Inhalable Aerosol, g	Cascade-Impactor Data		Particle Count at 3 min after Dissemination (IIPRI Counter)	
					Stage	μg	MMD	Particle Number of
-	-	-	-	-	-	-	-	-
-	-	-	-	-	-	D U D	-	-

CONFIDENTIAL

CONFIDENTIAL

CONFIDENTIAL

TABLE III-3. DATA FOR TEST CS-3

Observations: Pressed in inverted position; well formed; reasonably strong; 34.0 g of pyrotechnic mix; pressed at 5600 lb; density 1.0 g/cm³; burning time more than 13 sec.

Time, min	C _{max} μg	% C _{max}	% C _{max} at T ₀	Inhalable Aerosol, g	Cascade-Impactor Data		Particle Count at 3 min after Dissemination (LITRI Counter)			
					Stage	μg	MMD, μm	Particle Size, μm	Number of Particles	% of Cumulative Particles
3.5	3438	48.5*	50.0*	6.8*	1	Trace	1.0-1.4	2463	22.6	22.6
8.5	3291	46.0*			2	5.0	1.4-2.0	6595	60.4	83.0
13.5	3038	42.3*			3	10.02	2.0-2.8	1754	16.0	99.0
18.5	3038	42.3*			4	262.5	2.8-4.0	102	0.9	99.9
23.5	2917	41.2*			Filter	7.5	4.0-5.6	8		
28.5	2719	37.6*					5.6-8.0	4		CONFIDENTIAL

*These figures are conservative. High loading of the filters decreased air flow and sample size.

-118-
CONFIDENTIAL

CONFIDENTIAL

TABLE III-4, DATA FOR TEST CS-4

Observations: Pressed dry in inverted position at 8900 lb load; strong cake; 34.0 g of pyrotechnic mix; top not flush; burning time more than 15 sec.

Time, min	C _{max} μg	% C _{max} at T ₀	Inhalable Aerosol, g	Cascade-Impactor Data		Particle Count at 3 min after Dissemination (IITRI Counter)	
				Stage	MMD, μm	Particle Size, μm	Particle Number of Particles
3.5	2975	42.3*	6.4*	1	0.0	1.0-1.4	3104
8.5	2800	37.2*		2	1.0	1.4-2.0	7457
13.5	3400	47.2*		3	8.75	2.0-2.8	1988
18.5	3400	47.1*		4	327.5	2.8-4.0	2
23.5	3200	44.8*		Filter	23.0	4.0-5.6	2
28.5	2875	40.7*				5.6-8.0	1

CONFIDENTIAL

* These figures are conservative. High loading of the filters decreased air flows and sample sizes.

CONFIDENTIAL

CONFIDENTIAL

TABLE III-5. DATA FOR TEST CS-5

Observations: Pressed wet with methyl alcohol at 8900 lb load;
36.0 g pyrotechnic mix; strong cake;
burning time could not be measured
because of obscuration by smoke.

Time, min	μg	% C_{max}	% C_{max} at T_0	Inhalable Aerosol, g	Cascade-Impactor Data		Particle Count at 3 min after Dissemination (ITRI Counter)	Particle Number of % of Cumulative			
					Stage	MMD, μ					
3.5	3070	40.0*	50.0*	7.2*	1	0.0	1.6	1.0-1.4	3881	66.4	66.4
8.5	3595	47.5*			2	10.75		1.4-2.0	1944	33.2	99.6
13.5	3800	49.6*			3	17.25		2.0-2.8	25	0.4	100.0
18.5	3625	47.4*			4	265.0		2.8-4.0	3		
23.5	2775	36.8*			Filter	7.25		4.0-5.6	3		
28.5	2538	33.6*						5.6-8.0	0		CONFIDENTIAL

* These figures are conservative. High loading of the filters decreased air flow and sample size.

CONFIDENTIAL

CONFIDENTIAL

TABLE III-4, DATA FOR TEST CS-4

Observations: Pressed dry in inverted position at 8900 lb load; strong cake; 34.0 g of pyrotechnic mix; top not flush; burning time more than 15 sec.

Time, min.	C _{max} μg	C _{max} %	% C _{max} at T ₀	Inhalable Aerosol, g	Cascade-Impactor Data		Particle Count at 3 min after Dissemination (IITRI Counter)			
					Stage	MMD, μg	Particle Size, μ	Particle Number	% of Particles	Cumulative %
3.5	2975	42.3*	47.2*	6.4 [†]	1	0.0	1.0-1.4	3104	24.8	24.8
8.5	2800	37.2*			2	1.0	1.4-2.0	7457	59.4	84.2
13.5	3400	47.2*			3	8.75	2.0-2.8	1988	15.8	100.0
18.5	3400	47.1*			4	327.5	2.8-4.0	2		
23.5	3200	44.8*			Filter	23.0	4.0-5.6	2		
28.5	2875	40.7*					5.6-8.0	1		

* These figures are conservative. High loading of the filters decreased air flows and sample sizes.

CONFIDENTIAL

CONFIDENTIAL

CONFIDENTIAL

TABLE III-5. DATA FOR TEST CS-5

Observations: Pressed wet with methyl alcohol at 8900 lb load;
 36.0 g pyrotechnic mix; strong cake;
 burning time could not be measured
 because of obscuration by smoke.

Time, min	μg	% C _{max}	% C _{max} at T ₀	Inhalable Aerosol, g	Cascade-Impactor		Particle Count at 3 min after Dissemination (ULTRI Counter)			
					Stage	Data μg	MMD, μ	Particle Number of Size, μ	% of Cumulative Particles	
3.5	3000	40.0*	50.0*	7.2*	1	0.0	1.0-1.4	3881	66.4	66.4
8.5	3595	47.5*			2	10.75	1.4-2.0	1944	33.2	99.6
13.5	3800	49.6*			3	17.25	2.0-2.8	25	0.4	100.0
18.5	3625	47.4*			4	265.0	2.8-4.0	3		
23.5	2775	36.8*			Filter	7.25	4.0-5.6	3		
28.5	2538	33.6*					5.6-8.0	0		CONFIDENTIAL

*These figures are conservative. High loading of the filters decreased air flow and sample size.

CONFIDENTIAL

CONFIDENTIAL

TABLE III-6. DATA FOR TEST CS-6

Observations: Pressed wet with methyl alcohol at 8900 lb load;
35.0 g pyrotechnic mix; strong cake;
cover flush; burning time 17+ sec.

Time, min	μg	% C_{max}	% C_{max} at T ₀	Inhalable Aerosol, g	Cascade-Impactor Data			Particle Count at 3 min after Dissemination (IJTRI Counter)			
					Stage	μg	MMD, μ	Particle Number of Particles	% of Cumulative Particles		
3.5	3050	42.1*	51.8*	7.26*	1	0.0	1.5	1.0-1.4	3158	70.0	70.0
8.5	3375	45.9*			2	0.0		1.4-2.0	1327	29.4	99.4
13.5	3375	51.8*			3	12.75		2.0-2.8	18	0.5	99.9
18.5	3575	47.4*			4	262.5		2.8-4.0	1		
23.5	3075	42.0*			Filter	12.75		4.0-5.6	1		
28.5	2500	34.2*						5.6-8.0	0		

* These figures are conservative. High loading of the filters decreased air flow and sample size.

CONFIDENTIAL

CONFIDENTIAL

TABLE III-7. DATA FOR TEST CS-7

Observations: Pressed dry at 8900 lb load; 33.0 g pyrotechnic mix;
 surface wetted with 2 cc methyl alcohol;
 burning time 18 sec.

Time, min	μ g	% C _{max}	% C _{max} at T ₀	Inhalable Aerosol, g	Cascade-Impactor		Particle Count at 3 min after Dissemination (IITRI Counter)		
					Stage	Data MMD, μ	Particle Number of Size, μ	% of Cumulative Particles	
1.2	1383	63.8	65.0	8.6	1	0.0	1.0-1.4	2104	82.5
6.2	1291	59.0			2	1.5	1.4-2.0	440	17.3
11.2	1175	53.7			3	2.75	2.0-2.8	2	
16.2	1019	46.1			4	200.0	2.8-4.0	1	
21.2	915	41.9			Filter	8.75	4.0-5.6	0	
26.2	755	34.6					5.6-8.0	0	

CONFIDENTIAL

CONFIDENTIAL

CONFIDENTIAL

TABLE III-8. DATA FOR TEST CS-8

Observations: Pressed dry at 8900 lb load;
surface wetted with methyl alcohol;
burning time 19 sec.

Time, min	μ g	% C _{max} at T ₀	Inhalable Aerosol, g	Cascade-Impactor		Particle Count at 3 min after Dissemination (LITRI Counter)				
				Stage	Data MMD, μ	Particle Size, μ	Number of Particles	% of Cumulative Particles		
1.2	1550	71.5	9.5	1	0.0	1.6	1.0-1.4	3733	86.7	86.7
6.2	1458	66.0		2	0.0		1.4-2.0	564	13.1	99.8+
11.2	1433	64.6		3	30.75		2.0-2.8	3		
16.2	1292	58.3		4	280.0		2.8-4.0	1		
21.2	1167	53.2		Filter	17.25		4.0-5.6	0		
26.2	1056	48.2					5.6-8.0	0		CONFIDENTIAL

CONFIDENTIAL

CONFIDENTIAL

TABLE III-9, DATA FOR TEST CS-9

Observations: Pressed dry at 8930 lb load;
 33.0 g of pyrotechnic mix;
 burning time less than 25 sec.

Time, min	μg	% C_{max}	% C_{max} at T_0	Inhalable Aerosol, g	Cascade-Impactor Data			Particle Count at 3 min after Dissemination (LITRI Counter)			
					Stage	μg	MMD, μ	Particle Number of Size, μ	% of Cumulative Particles		
1.2	1525	70.3	72.0	9.5	1	0.0	1.5	1.0-1.4	1872	87.8	87.8
6.2	1433	65.0			2	0.25		1.4-2.0	267	12.2	100.0
11.2	1292	58.3			3	7.25		2.0-2.8	0		
16.2	941	42.5			4	227.5		2.8-4.0	0		
21.2	975	44.4			Filter	15.75		4.0-5.6	0		
26.2	760	34.8						5.6-8.0	0		

CONFIDENTIAL

CONFIDENTIAL

CONFIDENTIAL

TABLE III-10. DATA FOR TEST BZ-1

Observations: Pressed dry at 8900 lb load;
33.0 g of pyrotechnic mix;
burning time 20 sec.

Time, min	µg	% C _{max}	% C _{max} at T ₀	Inhalable Aerosol, g	Cascade-Impactor Data			Particle Count at 3 min after Dissemination (IFRI Counter)			
					Stage	µg	MMD, µ	Particle Number	% of Cumulative Particles		
1.2	1500	68.8	72.0	9.5	1	0.0	1.6	1.0-1.4	3207	76.0	76.0
6.2	14.7	64.2			2	3.25		1.4-2.0	1008	24.0	100.0
11.2	1242	56.0			3	24.50		2.0-2.8	4		
16.2	1119	50.4			4	222.50		2.8-4.0	0		
21.2	887	40.2			Filter	12.25		4.0-5.6	0		
26.2	775	35.4						5.6-8.0	0		

CONFIDENTIAL

CONFIDENTIAL

break up when the bomblets were removed from the die.

(U) In Tests 5 and 6 pressing was done in two stages. In the first stage the mix was pressed at 5600 pounds load. The forming punch was then removed from the funnel and approximately 2 ml of methyl alcohol was poured over the cake surface in order to soften the pyrotechnic mix. The punch was reinserted and pressed at 8900 pounds load. This wet pressing yielded a more dense and stronger cake. This procedure, however, only provides an increase of approximately 6% in the density.

(U) In Tests 7 and 8 pressing was done dry, but a small amount of methyl alcohol was dripped onto the surface of the cake, after removal from the die, in order to bind the particles and strengthen the cake. This small amount of alcohol did not seem to alter the burning characteristics of the bomblet. This procedure was used in producing the 160 final bomblets.

III. TESTS OF BZ BOMBLETS

(U) A total of 11 tests were made with the BZ loaded bomblets. The results of these tests appear in Tables III-11 and III-19 of this report.

(U) Of the 11 tests, two were duds because of failure of the tubular pyrofuse to ignite. Four bomblets flamed, and a low dissemination efficiency resulted. The five units that functioned well showed a somewhat poorer dissemination efficiency than that obtained with the CS-loaded bomblets. It is apparent from these five tests that the particle size of the aerosol is more variable than that obtained in the CS tests. On the basis of these few tests, there also seems to be a correlation between low mass mean diameter (MMD) and high dissemination efficiency.

(U) In attempts to reduce flaming of the devices, the size of the orifices was changed in Tests 7 and 8. In Test 7, two sheet-copper orifices, 0.120

CONFIDENTIAL

TABLE III-11. DATA FOR TEST BZ-1

Observations: Quick-match unit; initiated properly and did not flame;
26.0 g of pyrotechnic mix; burning time 17 sec.

Time, BZ, min	C _{max} , %	C _{max} at T ₀ , %	Inhalable Aerosol, g	Cascade-Impactor Data		Particle Count at 3 min after Dissemination (IIRI Counter)					
				Stage	BZ + BA, MMD, μg	Particle Size, μ	Dissemination (IIRI Counter) Particle Number of Particles	% of Cumulative Particles			
2	530	22.6	25.5	3.6	1	5.2	1.2	1.0-1.4	4334	52.3	52.3
7	548	23.0			2	6.0		1.4-2.0	3832	46.3	98.6
12	540	26.8			3	47.7		2.0-2.8	109	1.3	99.9
17	560	27.7			4	120.0		2.8-4.0	0		
22	506	25.4			Filter	100.0		4.0-5.6	1		
27	537	22.5						5.6-8.0	0		

CONFIDENTIAL

CONFIDENTIAL

CONFIDENTIAL

TABLE III-12. DATA FOR TEST BZ-2

Observations: Quick-match unit; cover not flush with top; initiated properly and did not flame; 23.8 g of pyrotechnic mix; burning time 22+ sec.

Time, BZ, min, g	% C _{max}	% C _{max} at T ₀	Inhalable Aerosol, g	Cascade-Impactor		Particle Count at 3 min after Dissemination (ITRI Counter)					
				Stage	Data BZ, g, MMD, μ	Particle Size, μ	Dissemination Number of Particles	% of Cumulative Particles			
2	670	25.6	30.6	4.8	1	9.5	1.1	1.0-1.4	4368	46.7	46.7
7	767	29.0			2	6.5		1.4-2.0	4723	50.5	97.2
12	762	28.6			3	52.0		2.0-2.8	244	2.6	99.8+
17	750	27.9			4	82.5		2.8-4.0	5		
22	780	29.4			Filter	110.5		4.0-5.6	4		
27	672	25.6						5.6-8.0	1		
									9345		

CONFIDENTIAL

CONFIDENTIAL

CONFIDENTIAL

TABLE III-13. DATA FOR TEST BZ-3

Observations: Quick-match unit; case distorted; cover did not fit well; 27.7 g of pyrotechnic mix; flamed.

Time, min	BZ, g	C _{max} , %	C _{max} at T ₀ , %	Inhalable Aerosol, g	Cascade-Impactor Data	Particle Count at 3 min after	
						Dissemination (IITRI Counter)	% of Cumulative
					Stage	Size, μ	Particles
7	45	1.8	1.3	0.27	1	1.0-1.4	608
					2	1.4-2.0	174
					3	2.0-2.8	52
					4	2.8-4.0	15
					Filter	4.0-5.6	4
						5.6-8.0	2
							856
							71.0
							20.5
							6.1
							1.9
							0.4
							100.0

CONFIDENTIAL

CONFIDENTIAL

CONFIDENTIAL

TABLE III-14. DATA FOR TEST BZ-4

Observations: Quick-match unit, initiated properly and burned for 30 sec; no flame; 26.2 g of pyrotechnic mix.

Time, min.	Bz, μ g	% C _{max}	% C _{max} at T ₀	Inhalable Aerosol, g	Cascade-Impactor Data	Particle Count at 3 min after Dissemination (IITRI Counter)					
						Stage	Particle Size, μ m	Dissemination (IITRI Counter) Particle Number	% of Cumulative Particles		
2	395	16.5	24.0	3.5	1	10.5	1.3	1.0-1.4	4442	53.8	53.8
7	370	15.2			2	7.0		1.4-2.0	3635	44.0	97.8
12	510	21.0			3	70.5		2.0-2.8	169	2.0	99.8
17	453	18.6			4	66.5		2.8-4.0	2		
22	410	16.9			Filter	112.0		4.0-5.6	0		
27	360	14.9						5.6-8.0	1		
										8249	

CONFIDENTIAL

CONFIDENTIAL

TABLE III-15. DATA FOR TEST BZ-5

Observations: Quick-match unit; initiated properly;
 obscured by smoke in 5 sec;
 hole burned in top;
 tape stayed on at circumference;
 27.7 g of pyrotechnic mix.

Time, min	BZ, μ g	% C _{max}	% C at T ₀	Inhalable Aerosol, g	Cascade-Impactor Data		Particle Count at 3 min after Dissemination (IITRI Counter)				
					Stage	BZ + BA, NMD, μ g	Particle Size, μ	Dissemination Particle Number, % of Particles	Cumulative Particles, %		
2	596	35.7	39.6	6.1	1	10.0	0.96	1.0-1.4	4368	44.4	44.4
7	560	33.0			2	6.0		1.4-2.0	5176	52.6	97.0
12	645	37.8			3	48.0		2.0-2.8	303	3.0	100.0
17	653	37.8			4	115.5		2.8-4.0	0	0	
22	763	45.2			Filter	131.2		4.0-5.6	0	0	CONFIDENTIAL
27	612	36.0						5.6-8.0	0	0	
											9847

CONFIDENTIAL

TABLE III-16. DATA FOR TEST BZ-6

Observations: Quick-match unit; cover fit well; initiated properly but flames after 5 to 10 sec; 26.5 g of pyrotechnic mix.

Time, BZ, min.	BZ, g.	% C _{max} at T ₀	% C _{max} at T ₀	Inhalable Aerosol, g.	Cascade-Impactor Data		Particle Count at 3 min after Dissemination (IITRI Counter)				
					Stage	BZ, BA, MVD, g.	Particle Number	% of Cumulative Particles			
2	265	16.4	16.0	2.4	1	0.0	1.5	1.0-1.4	2234	74.0	74.0
7	218	13.2			2	2.0		1.4-2.0	691	22.9	96.9
12	208	12.7			3	11.8		2.0-2.8	72	2.4	99.3
17	202	12.1			4	106.2		2.8-4.0	17	0.6	99.9
22	188	11.5			Filter	18.0		4.0-5.6	3		
27	190	11.8						5.6-8.0	0		

3017 CONFIDENTIAL

CONFIDENTIAL

CONFIDENTIAL

TABLE III-17. DATA FOR TEST BZ-7

Observations: Quick-match unit;
orifice size reduced to 0.120 in.;
flamed; 27.2 g of pyrotechnic mix.

Time, BZ, min	BZ, g	% C _{max} at T ₀	% C _{max} at T ₀	Inhalable Aerosol, g	Cascade-Impactor Data		Particle Count at 3 min after Dissemination (IITRI Counter)				
					Stage	BZ, DA, MMD, μg	μ	Particle Number of Particles	% of Particles	Cumulative %	
2	144	8.7	10.4	1.6	1	8.5	1.5	1.0-1.4	2203	41.6	41.6
7	212	12.8			2	6.5		1.4-2.0	2537	47.9	89.5
12	165	9.8			3	8.0		2.0-2.8	396	7.5	97.0
17	164	9.7			4	46.0		2.8-4.0	111	2.1	99.1
22	131	7.8			Filter	21.8		4.0-5.6	44	0.8	99.9+
27	103	6.2						5.6-8.0	<u>2</u>		
									5293		

CONFIDENTIAL

CONFIDENTIAL

TABLE III-18. DATA FOR TEST BZ-8

Observations: Quick-match unit; cover not flush;
 2 additional holes 0.128 in. in diameter,
 drilled in top; flamed after 8 sec;
 26.6 g of pyrotechnic mix.

Time, BZ, C min. Eq.	% C max at T ₀	Inhalable Aerosol, g	Cascade-Impactor Data		Particle Count at 3 min after Dissemination (IIRI Counter)					
			Stage	BZ + BA, mg	Size, μ	Particle Number of Particles	% of Cumulative Particles			
2	210	13.0	13.0	1	7.0	2.0	1.0-1.4	2738	72.7	72.7
				2	6.0		1.4-2.8	886	23.6	96.3
				3	11.2		2.8-4.0	110	2.9	99.2
				4	61.5		4.0-5.6	23	0.6	99.8
				Filter	12.0		5.6-8.0	4		
								<u>2</u>		
								3763		CONFIDENTIAL

CONFIDENTIAL

TABLE III-19, DATA FOR TEST BZ-10

Observations: Braided pyrofuse; initiated well; thick smoke; could not get burning time; 23.6 g of pyrotechnic mix.

Time, min	BZ, μ g	% C_{max}	% C_{max} at T_0	Inhalable Aerosol, g	Cascade-Impactor		Particle Count at 3 min after Dissemination (LITRI Counter)				
					Stage	Data BZ, BA, MMD, μ	Dissemination Particle Number of	% of Cumulative Particles			
2	560	32.4	35.0	5.5	1	16.0	0.68	1.0-1.4	3,634	34.6	34.6
7	625	35.6			2	8.5		1.4-2.8	5,928	56.5	91.1
12	558	31.6			3	36.0		2.8-4.0	934	8.9	100.0
17	573	32.3			4	85.0		4.0-5.6	4		
22	524	30.2			Filter	147.0		5.6-8.0	0		
27	552	32.0							0		
										10,500	

CONFIDENTIAL

CONFIDENTIAL

in. in diameter, were sealed over the existing holes to reduce the vent area. In Test 8, two additional holes, 0.128 in., were drilled in the cover to increase the vent area. In both tests, flaming occurred.

(U) In tests 9, 10, and 11, the quick match was replaced with metallic pyrofuse. In Tests 9 and 11, the pyrofuse was in the form of a tube approximately 1/8 in. in diameter, the pyrofuse did not ignite, even though it was severely distorted by the heat and the pressure from the primer in Test 11. In Test 10, the pyrofuse was in the form of a braided wire. This unit functioned properly and did not flame.

IV. LOADING OF 160 CS BOMBLETS

(U) In loading of 160 bomblets the procedure described in Section II of this appendix was followed. However, in order to facilitate the loading, a fixture was used to hold the funnel and punch in an inverted position. This fixture is shown in Figures III-1 and III-2, together with some of the loaded bomblets. The bomblets were loaded with 33.0 g of pyrotechnic mix, pressed dry at 8900 lb. load, sprayed with enough methyl alcohol to wet the surface, and removed from the die. The quick match was then inserted into the formed groove, the cover put in place, and a small piece of masking tape was used to seal the discharge ports. The bomblets were individually wrapped in plastic bags and sealed in friction cap cans.

(U) In order to insure that these units would function, the 15th, 80th, and 140th bomblets loaded were tested for function only. These tests were performed and proper ignition occurred. All three of the tests were successful.



Figure III-1. Fixture Used for Holding Funnel, Die, and Forming Punch in an Inverted Position



UNCLASSIFIED

Figure III-2. Fixture Funnel, Die, and Forming Punch Assembled and Ready for Pressing

UNCLASSIFIED

Security Classification

DOCUMENT CONTROL DATA - R & D		
<i>(Security classification of title, body of abstract and indexing annotation must be entered when the overall report is classified)</i>		
1. ORIGINATING ACTIVITY <i>(Corporate author)</i> Honeywell Incorporation Ordnance Division Hopkins, Minnesota		2a. REPORT SECURITY CLASSIFICATION CONFIDENTIAL
		2b. GROUP 4
3. REPORT TITLE BLU-30/B (NONHAZARDOUS) BOMBLET (U)		
4. DESCRIPTIVE NOTES <i>(Type of report and inclusive dates)</i> Final Report June 1966 to May 1968		
5. AUTHOR(S) <i>(First name, middle initial, last name)</i> Spurbeck, K.		
6. REPORT DATE July 1968	7a. TOTAL NO. OF PAGES 147	7b. NO. OF REFS 0
8a. CONTRACT OR GRANT NO. AF 08(635)-5863	9a. ORIGINATOR'S REPORT NUMBER(S)	
b. PROJECT NO.		
c.	9b. OTHER REPORT NO(S) <i>(Any other numbers that may be assigned this report)</i> AFATL-TR-68-87	
d.		
10. DISTRIBUTION STATEMENT In addition to security requirements which must be met, this document is subject to special export controls and each transmittal to foreign governments or foreign nationals may be made only with prior approval of the Air Force Armament Laboratory (ATCC), Eglin AFB, Florida 32542.		
11. SUPPLEMENTARY NOTES Available in DDC.	12. SPONSORING MILITARY ACTIVITY Air Force Armament Laboratory Air Force Systems Command Eglin Air Force Base, Florida 32542	
13. ABSTRACT (U) This report discusses the design and development of the BLU-30/B23 bomblet from its inception in June 1966 to prototype delivery to the Air Force for flight tests in May 1968. The BLU-30/B23 is a submunition cluster bomblet designed for delivery from the SUU-13/A dispenser. It provides, upon ground impact, thermal dissemination of agents CS or BZ. Theoretical area coverage and effectiveness of this bomblet for use in various counterinsurgency situations are also presented. Submunition dissemination tests conducted at Illinois Institute of Technology Research Institute (IITRI) during this program demonstrated efficiencies as high as 76 percent for CS and 40 percent for BZ. (U) Problems encountered during Air Force testing indicate additional development of the submunition is required before a useable system would result. The primary problems encountered during the program were the determination of the most reliable ignition method for the CS and BZ pyrotechnic payloads, the compatibility of the Hooker 283 BZ pyrotechnic loading procedures with the submunition case material and the relatively low dissemination efficiencies with BZ. These problems and their resolutions and/or recommendations for further study are detailed in this report.		

DD FORM 1 NOV 65 1473

UNCLASSIFIED

Security Classification

14. WORDS	LINK A		LINK B		LINK C	
	ROLE	WT	ROLE	WT	ROLE	WT
Nonhazardous						
Bomblet						
Sub-bomblet						
BLU-30/B Bomblet Cluster						
Thermal Dissemination						
Development						
Impact Pattern						
Area Coverage						
FMU- 6S/B Fuze						